

Smart choice for power

**xantrex**

**GPI B-XHR  
GPI B-XFR  
GPI B-XFR3**

**Operating Manual**

**Internal GPI B Interface  
for XHR/ XFR Series  
Programmable DC  
Power Supplies**

[www.xantrex.com](http://www.xantrex.com)



# **Internal GPIB Interface for XHR and XFR Series Programmable DC Power Supplies**

## **Operating Manual**

## **About Xantrex**

Xantrex Technology Inc. is a world-leading supplier of advanced power electronics and controls with products from 50 watt mobile units to one MW utility-scale systems for wind, solar, batteries, fuel cells, microturbines, and backup power applications in both grid-connected and stand-alone systems. Xantrex products include inverters, battery chargers, programmable power supplies, and variable speed drives that convert, supply, control, clean, and distribute electrical power.

## **Trademarks**

Xantrex is a registered trademark of Xantrex International.

Other trademarks, registered trademarks, and product names are the property of their respective owners and are used herein for identification purposes only.

## **Notice of Copyright**

Internal GPIB Interface for XHR and XFR Series Programmable DC Power Supplies Operating Manual©  
October 2007 Xantrex Technology Inc. All rights reserved.

## **Disclaimer**

UNLESS SPECIFICALLY AGREED TO IN WRITING, XANTREX TECHNOLOGY INC. ("XANTREX")

(a) MAKES NO WARRANTY AS TO THE ACCURACY, SUFFICIENCY OR SUITABILITY OF ANY TECHNICAL OR OTHER INFORMATION PROVIDED IN ITS MANUALS OR OTHER DOCUMENTATION.

(b) ASSUMES NO RESPONSIBILITY OR LIABILITY FOR LOSS OR DAMAGE, WHETHER DIRECT, INDIRECT, CONSEQUENTIAL OR INCIDENTAL, WHICH MIGHT ARISE OUT OF THE USE OF SUCH INFORMATION. THE USE OF ANY SUCH INFORMATION WILL BE ENTIRELY AT THE USER'S RISK.

## **Date and Revision**

October 2007 Revision A

## **Part Number**

TM-GPRF-01XN

## **Contact Information**

Telephone: 1 800 733 5427 (toll free North America)  
1 858 450 0085 (direct)

Fax: 1 858 678 4482 (direct)

Email: [prg.info@xantrex.com](mailto:prg.info@xantrex.com)

Web: [www.xantrex.com](http://www.xantrex.com)

# About This Manual

This Operating Manual is for the internal GPIB interface, a microprocessor-controlled option card for XHR Series and XFR Series DC output power supplies.

## Scope

This manual provides you with descriptions and specifications, user options, and configuration instructions, in addition to a command set which enables you to manage the power supply from an external source. Error messages and calibration procedures are also included.

## Audience

This manual is designed for the user who is familiar with basic electrical theory, especially as they apply to the operation of power supplies. This implies a recognition of Constant Voltage and Constant Current operating modes and the control of input and output power, as well as the observance of safe techniques while making supply or pin connections and any changes in switch settings. The user should also have experience with a computer-based communications software package.

Refer to your power supply manual for installation, configuration, and operating procedures for your power supply

## Organization

This Manual is organized into four chapters.

**Section 1 Features and Specifications** Describes the power supply and lists its features and specifications.

**Section 2 Installation and Configuration** Goes through basic setup procedures. Describes inspection, cleaning, shipping, and storage procedures. Includes additional options for configuring the GPIB interface for operation.

**Section 3 Operation** Lists the complete command set, status registers, and error codes.

**Section 4 Calibration** Provides detailed procedures for voltage and current mode calibration as well as over voltage protection (OVP) calibration. Includes calibration for programming and readback accuracy.

## Conventions Used

### T Power Supply Safety



#### **WARNING—High Energy and High Voltage**

Exercise caution when using and calibrating a power supply. High energy levels can be stored at the output voltage terminals on a power supply in normal operation. In addition, potentially lethal voltages exist in the power circuit and on the output and sense connectors of a power supply with a rated output greater than 40 V. Filter capacitors store potentially dangerous energy for some time after power is removed.

---



#### **CAUTION**

Operate the power supply in an environment free of flammable gases or fumes. To ensure that the power supply's safety features are not compromised, use the power supply as specified in this manual and do not substitute parts or make any unauthorized modifications. Contact the service technician for service and repair help. Repairs must be made by experienced service technicians only.

---

### Warnings, Cautions, and Notes

Warnings, cautions, and notes are defined and formatted in this manual as shown below.

---



#### **WARNING**

Describes a potential hazard which could result in injury or death, or, a procedure which, if not performed correctly, could result in injury or death.

---



#### **CAUTION**

Describes a procedure which, if not performed correctly, could result in damage to data, equipment, or systems.

---

Reference A

#### **Note**

Describes additional operating information which may affect the performance of the equipment.

---

# Contents

<b>Section 1.</b>	Description . . . . .	7
<b>Features and Specifications</b>	Features and Functions . . . . .	8
	Features . . . . .	8
	Programmable Functions . . . . .	8
	Readback Functions . . . . .	8
	Specifications . . . . .	9
<b>Section 2.</b>	Introduction . . . . .	15
<b>Installation and Configuration</b>	Initial Inspection . . . . .	15
	Basic Setup Procedure . . . . .	19
	IEEE-488 Primary Address Selection . . . . .	20
	Power On Service Request (PON SRQ) . . . . .	21
	Remote/Local Operation . . . . .	21
	Remote/Local Mode Startup . . . . .	21
	Remote Mode Operation . . . . .	22
	Local Mode Operation . . . . .	23
	Setting Local Lockout . . . . .	23
	IEEE-488 Controller Connection . . . . .	24
	Internal PCB Jumper Selections . . . . .	24
	OVP Selection . . . . .	24
	TTL Shutdown . . . . .	25
	User Signals . . . . .	26
	Connector J7 User Signals . . . . .	26
	J7 Cable Connection . . . . .	27
<b>Section 3.</b>	Introduction . . . . .	29
<b>Operation</b>	GPIB Operation . . . . .	29
	Multiline Control Functions . . . . .	30
	Device Clear . . . . .	30
	Device Trigger . . . . .	31
	Parallel Poll . . . . .	31
	Local Lockout . . . . .	31
	Service Request . . . . .	32
	Serial Poll . . . . .	32
	Command Syntax . . . . .	33
	Manual Conventions . . . . .	33
	Command Format and Parameters . . . . .	33
	Command Strings . . . . .	35
	Command Terminators . . . . .	35
	Order . . . . .	35
	Command Summary . . . . .	36
	Command Reference . . . . .	39

## Contents

	Accumulated Status, Status, and Fault Registers . . . . .	46
	Error Codes . . . . .	47
	Troubleshooting . . . . .	48
	Diagnostic LEDs . . . . .	48
<b>Section 4.</b>	Introduction . . . . .	49
<b>Calibration</b>	Voltage Mode Calibration. . . . .	50
	Voltage Calibration Setup . . . . .	50
	Voltage Program Calibration Procedure . . . . .	50
	Voltage Readback Calibration Procedure . . . . .	50
	Current Mode Calibration. . . . .	52
	Current Calibration Setup . . . . .	52
	Current Program Calibration Procedure . . . . .	52
	Current Readback Calibration Procedure . . . . .	53
	Over Voltage Protection (OVP) Calibration . . . . .	54
<b>Warranty and</b>	Warranty . . . . .	55
<b>Return</b>	Return Material Authorization Policy . . . . .	57
<b>Information</b>		



# Section 1. Features and Specifications

## Description

The internal GPIB interface card allows you to operate your power supply from a computer controller via the IEEE-488 communications bus. See Figure 1.1, “Sample Configuration using GPIB Interface”.

The GPIB interface allows complete remote programming of your power supply, including status reporting, settings query, and interrupt generation with user-designated fault conditions. Both the voltage and current output are precisely programmed directly in volts and amps with 16-bit resolution. Additionally, the built-in DVM and current shunt measure the actual power supply output and provide you with 16-bit readback. The programming command set is easy-to-use and includes software calibration commands. The interface card comes standard with several protection features such as programmable over voltage protection, foldback, load isolation signal, and soft limits.

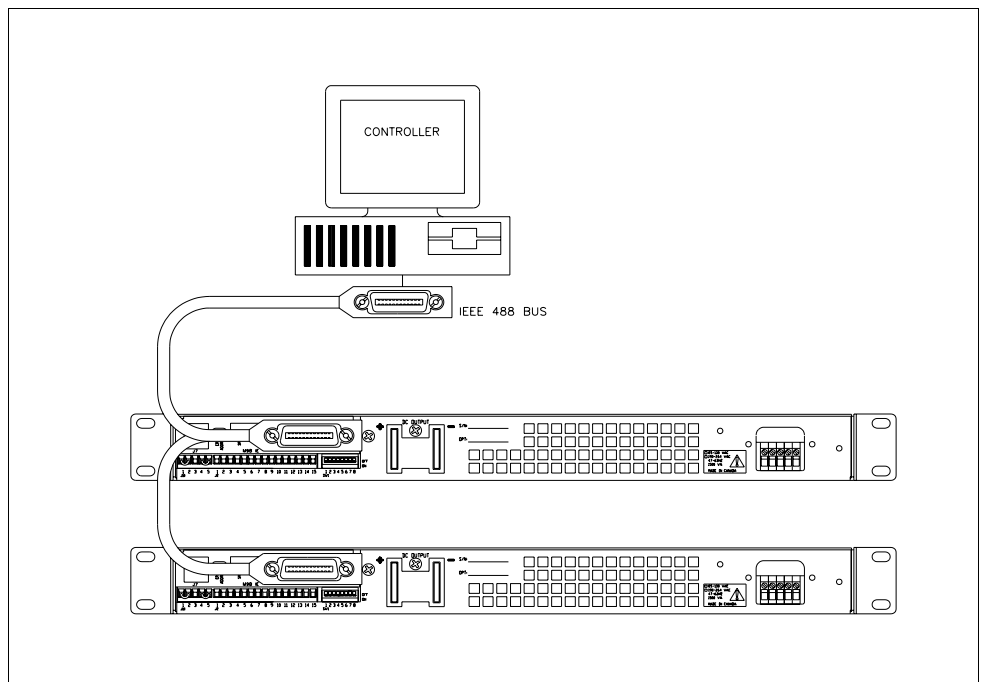

**Figure 1.1** Sample Configuration using GPIB Interface  
(1200 Watt DC Power Supplies Shown)

## Features and Specifications

### Features and Functions

## Features and Functions

- Features**
- 16-bit programming and readback of voltage and current
  - Programmable soft limits for voltage and current
  - Programmable over voltage protection with reset
  - Easy-to-use, self-documenting command set
  - Isolated user-programmable signals such as fault, polarity, isolation, and auxiliary signals
  - LED status signals: error, addressed, service request, over voltage protection, and remote operation
  - Foldback in CV or CC mode with reset
  - Local Lockout capability
  - Software calibration

- Programmable Functions**
- Output voltage and current
  - Soft limits for voltage and current
  - Overvoltage protection
  - Output enable/disable
  - Maskable fault interrupt
  - Hold and trigger
  - User-programmable output relay signals

- Readback Functions**
- Actual measured voltage and current
  - Voltage and current settings
  - Soft voltage and current limits
  - Overvoltage protection setting
  - Present and accumulated power supply status
  - Programming error codes
  - Fault codes
  - Power supply model and version identification
  - Firmware revision levels

## Specifications

The specifications in this section are warranted at 25°C ±5°C unless otherwise specified. All specifications are subject to change without notice.

**Table 1.1** Specifications for XFR 1200 W Series Supply with GPIB Interface Installed (7.5 V to 40 V)

<b>Models</b>	<b>7.5-140</b>	<b>12-100</b>	<b>20-60</b>	<b>35-35</b>	<b>40-30</b>
<b>Program Resolution</b>					
Voltage	1.16mV	1.8mV	3.08mV	5.4mV	6.2mV
Current	19.6mA	14mA	8.4mA	5.4mA	4.2mA
OVP	1.16mV	1.8mV	3.08mV	5.4mV	6.2mV
<b>Program Accuracy<sup>1</sup></b>					
Voltage	10mV ±0.12%	50mV ±0.12%	75mV ±0.12%	75mV ±0.3%	75mV ±0.3%
Current	500mA ±0.1%	460mA ±0.1%	250mA ±0.1%	200mA ±0.1%	150mA ±0.15%
OVP	80mV	150mV	200mV	350mV	400mV
<b>Readback Resolution</b>					
Voltage	1.16mV	1.8mV	3.08mV	5.4mV	6.2mV
Current	19.6mA	14mA	8.4mA	5.4mA	4.2mA
<b>Readback Accuracy<sup>1</sup></b>					
Voltage	30mV ±0.12%	60mV ±0.12%	75mV ±0.12%	75mV ±0.3%	75mV ±0.3%
Current	500mA ±0.1%	460mA ±0.1%	250mA ±0.1%	200mA ±0.1%	150mA ±0.15%

1. Apply accuracy specifications according to the following voltage program accuracy example:  
Set a model 20-60 power supply to 10 volts.  
The expected result will be within the range of 10 volts ± 75mV ± 0.12% of the set voltage of 10 volts.

## Features and Specifications

### Specifications

**Table 1.2** Specifications for XFR 1200 W Series Supply with GPIB Interface Installed (60 V to 600 V)

<b>Models</b>	<b>60-20</b>	<b>100-12</b>	<b>150-8</b>	<b>300-4</b>	<b>600-2</b>
<b>Program Resolution</b>					
Voltage	9.2mV	15.4mV	23.1mV	46.2mV	92.4mV
Current	2.8mA	1.68mA	1.12mA	0.56mA	0.28mA
OVP	9.2mV	15.4mV	23.1mV	46.2mV	92.4mV
<b>Program Accuracy<sup>1</sup></b>					
Voltage	150mV ±0.25%	150mV ±0.35%	225mV ±0.35%	225mV ±0.35%	250mV ±0.35%
Current	120mA ±0.1%	80mA ±0.1%	80mA ±0.1%	80mA ±0.1%	50mA ±0.1%
OVP	600mV	800mV	1.5V	3.0V	6V
<b>Readback Resolution</b>					
Voltage	9.2mV	15.4mV	23.1mV	46.2mV	92.4mV
Current	2.8mA	1.68mA	1.12mA	0.56mA	0.28mA
<b>Readback Accuracy<sup>1</sup></b>					
Voltage	150mV ±0.25%	150mV ±0.35%	225mV ±0.35%	225mV ±0.35%	250mV ±0.35%
Current	120mA ±0.1%	80mA ±0.1%	80mA ±0.1%	80mA ±0.1%	50mA ±0.1%

1. Apply accuracy specifications according to the following voltage program accuracy example:  
Set a model 20-60 power supply to 10 volts.  
The expected result will be within the range of 10 volts  $\pm$  75mV  $\pm$  0.12% of the set voltage of 10 volts.

**Table 1.3** Specifications for XFR 2800 W Series Supply with GPIB Interface Installed (7.5 V to 40 V)

Models	7.5-300	12-220	20-130	33-85	40-70
Program Resolution					
Voltage	1.16mV	1.8mV	3.08mV	5.1mV	6.2mV
Current	42.0mA	30.8mA	18.2mA	13.0mA	9.8mA
OVP	1.16mV	1.8mV	3.08mV	5.1mV	6.2mV
Program Accuracy <sup>1</sup>					
Voltage	10mV	50mV	75mV	75mV	75mV
	±0.12%	±0.12%	±0.12%	±0.3%	±0.3%
Current	900mA	750mA	500mA	425mA	350mA
	±0.1%	±0.1%	±0.1%	±0.1%	±0.1%
OVP	80mV	150mV	200mV	330mV	400mV
Readback Resolution					
Voltage	1.16mV	1.8mV	3.08mV	5.1mV	6.2mV
Current	42.0mA	30.8mA	18.2mA	13.0mA	9.8mA
Readback Accuracy <sup>1</sup>					
Voltage	30mV	60mV	75mV	75mV	75mV
	±0.12%	±0.12%	±0.12%	±0.3%	±0.3%
Current	900mA	750mA	500mA	425mA	350mA
	±0.1%	±0.1%	±0.1%	±0.1%	±0.1%

1. Apply accuracy specifications according to the following voltage program accuracy example:  
 Set a model 20-130 power supply to 10 volts.  
 The expected result will be within the range of 10 volts ± 75mV ± 0.12% of the set voltage of 10 volts.

## Features and Specifications

### Specifications

**Table 1.4** Specifications for XFR 2800 W Series Supply with GPIB Interface Installed (60 V to 600 V)

<b>Models</b>	<b>60-46</b>	<b>100-28</b>	<b>150-18</b>	<b>300-9</b>	<b>600-4</b>
<b>Program Resolution</b>					
Voltage	9.2mV	15.4mV	23.1mV	46.2mV	92.4mV
Current	6.44mA	3.92mA	2.52mA	1.26mA	0.56mA
OVP	9.2mV	15.4mV	23.1mV	46.2mV	92.4mV
<b>Program Accuracy<sup>1</sup></b>					
Voltage	150mV ±0.25%	150mV ±0.35%	225mV ±0.35%	225mV ±0.35%	250mV ±0.35%
Current	250mA ±0.1%	140mA ±0.15%	120mA ±0.1%	80mA ±0.1%	80mA ±0.1%
OVP	600mV	800mV	1.5V	3.0V	6V
<b>Readback Resolution</b>					
Voltage	9.2mV	15.4mV	23.1mV	46.2mV	92.4mV
Current	6.44mA	3.92mA	2.52mA	1.26mA	0.56mA
<b>Readback Accuracy<sup>1</sup></b>					
Voltage	150mV ±0.25%	150mV ±0.35%	225mV ±0.35%	225mV ±0.35%	250mV ±0.35%
Current	250mA ±0.1%	140mA ±0.15%	120mA ±0.1%	80mA ±0.1%	80mA ±0.1%

1. Apply accuracy specifications according to the following voltage program accuracy example:  
Set a model 20-130 power supply to 10 volts.  
The expected result will be within the range of 10 volts ± 75mV ± 0.12% of the set voltage of 10 volts

**Table 1.5** Specifications for XHR 1000 W Series Supply with GPIB Interface Installed (7.5 V to 60 V)

Models	7.5-130	20-50	33-33	40-25	60-18
Program Resolution					
Voltage	1.16mV	1.8mV	3.08mV	6.2mV	9.2mV
Current	42.0mA	30.8mA	18.2mA	9.8mA	6.44mA
OVP	1.16mV	1.8mV	3.08mV	6.2mV	9.2mV
Program Accuracy <sup>1</sup>					
Voltage	10mV	50mV	75mV	75mV	150mV
	±0.12%	±0.12%	±0.12%	±0.3%	±0.25%
Current	900mA	750mA	500mA	350mA	250mA
	±0.1%	±0.1%	±0.1%	±0.1%	±0.1%
OVP	80mV	150mV	200mV	400mV	600mV
Readback Resolution					
Voltage	1.16mV	1.8mV	3.08mV	6.2mV	9.2mV
Current	42.0mA	30.8mA	18.2mA	9.8mA	6.44mA
Readback Accuracy <sup>1</sup>					
Voltage	30mV	60mV	75mV	75mV	150mV
	±0.12%	±0.12%	±0.12%	±0.3%	±0.25%
Current	900mA	750mA	500mA	350mA	250mA
	±0.1%	±0.1%	±0.1%	±0.1%	±0.1%

1. Apply accuracy specifications according to the following voltage program accuracy example:  
 Set a model 20-50 power supply to 10 volts.  
 The expected result will be within the range of 10 volts ± 50mV ± 0.12% of the set voltage of 10 volts.

## Features and Specifications

### Specifications

**Table 1.6** Specifications for XHR 1000 W Series Supply with GPIB Interface Installed (100 V to 600 V)

<b>Models</b>	<b>100-10</b>	<b>150-7</b>	<b>300-3.5</b>	<b>600-1.7</b>
Program Resolution				
Voltage	15.4mV	23.1mV	46.2mV	92.4mV
Current	3.92mA	2.52mA	1.26mA	0.56mA
OVP	15.4mV	23.1mV	46.2mV	92.4mV
Program Accuracy <sup>1</sup>				
Voltage	150mV ±0.35%	225mV ±0.35%	225mV ±0.35%	250mV ±0.35%
Current	140mA ±0.15%	120mA ±0.1%	80mA ±0.1%	80mA ±0.1%
OVP	800mV	1.5V	3.0V	6V
Readback Resolution				
Voltage	15.4mV	23.1mV	46.2mV	92.4mV
Current	3.92mA	2.52mA	1.26mA	0.56mA
Readback Accuracy <sup>1</sup>				
Voltage	150mV ±0.35%	225mV ±0.35%	225mV ±0.35%	250mV ±0.35%
Current	140mA ±0.15%	120mA ±0.1%	80mA ±0.1%	80mA ±0.1%

1. Apply accuracy specifications according to the following voltage program accuracy example:  
Set a model 20-50 power supply to 10 volts.  
The expected result will be within the range of 10 volts  $\pm$  50mV  $\pm$  0.12% of the set voltage of 10 volts.



# Section 2. Installation and Configuration

## Introduction

To use this product, you must have the following equipment:

- a compatible model of DC output power supply
- IEEE-488 connector and cable
- computer with an IEEE-488 interface
- Computer-based communications software package

We usually install the GPIB interface in a power supply at the factory. Your local distributor or service center can also install the interface, especially for use in a previously-purchased supply already on site. You must then configure the GPIB Interface-enhanced supply for your system using the “Basic Setup Procedure” on page 19. Refer also to Figure 2.1, pg. 16, Figure 2.2, pg. 17 and Figure 2.3, pg. 18 for drawings of the front panel, the interface subplate, and the GPIB interface printed circuit board (PCB).

## Initial Inspection



### CAUTION

If you remove the unit's cover, use proper static control techniques to avoid damage to static-sensitive components on the printed circuit board.

---

On first receiving your unit, perform a quick physical check.

- Ensure each package contains a power supply with its GPIB interface board installed, and manuals for the power supply and the GPIB interface. Any additional parts shipped with the power supply will be identified in the supply's documentation.
- Inspect the unit for any signs of physical damage such as scratches, cracks, or broken switches, connectors, or displays.
- Check the printed circuit board and components if you suspect internal damage.

If the unit is damaged, save all packing materials and notify the carrier immediately. For additional information, please see the section titled, “Returning Power Supplies to the Manufacturer” in the manual shipped with your complete unit.

## Installation and Configuration

### Initial Inspection



#### CAUTION

Use proper static control techniques to avoid damage to static-sensitive components on the printed circuit board.

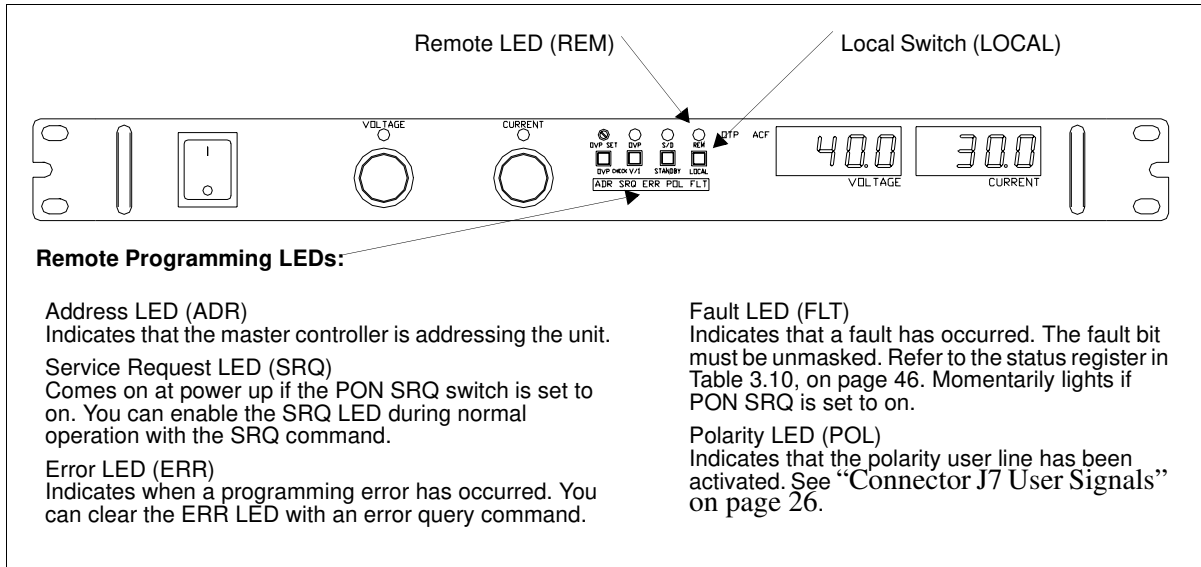

**Figure 2.1** Power Supply Front Panel with GPIB Interface Installed (1200 Watt Power Supply Shown)

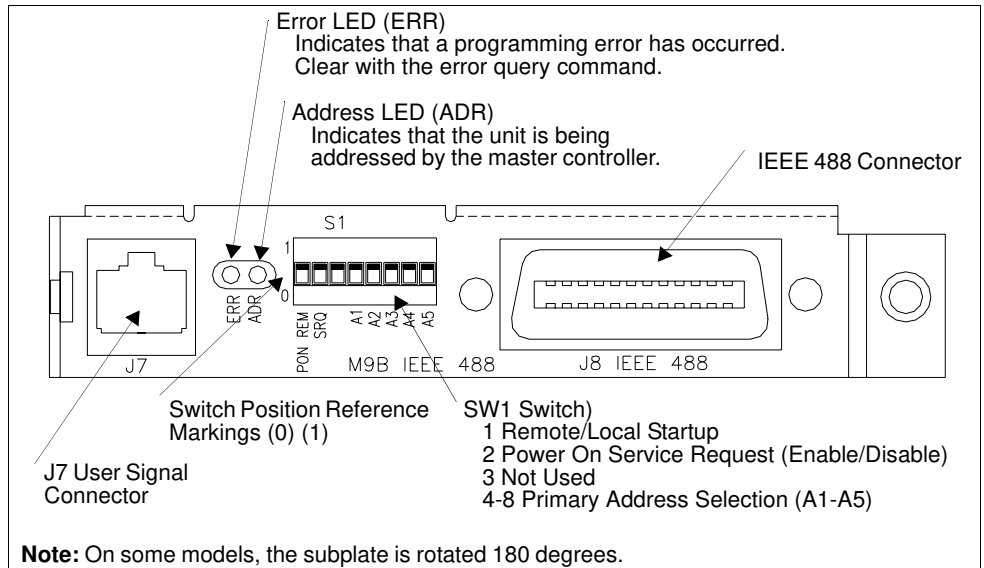

**Figure 2.2** GPIB Interface Subplate  
(Located on Power Supply Rear Panel)



**CAUTION**

Use proper static control techniques to avoid damage to static-sensitive components on the printed circuit board

## Installation and Configuration

### Initial Inspection

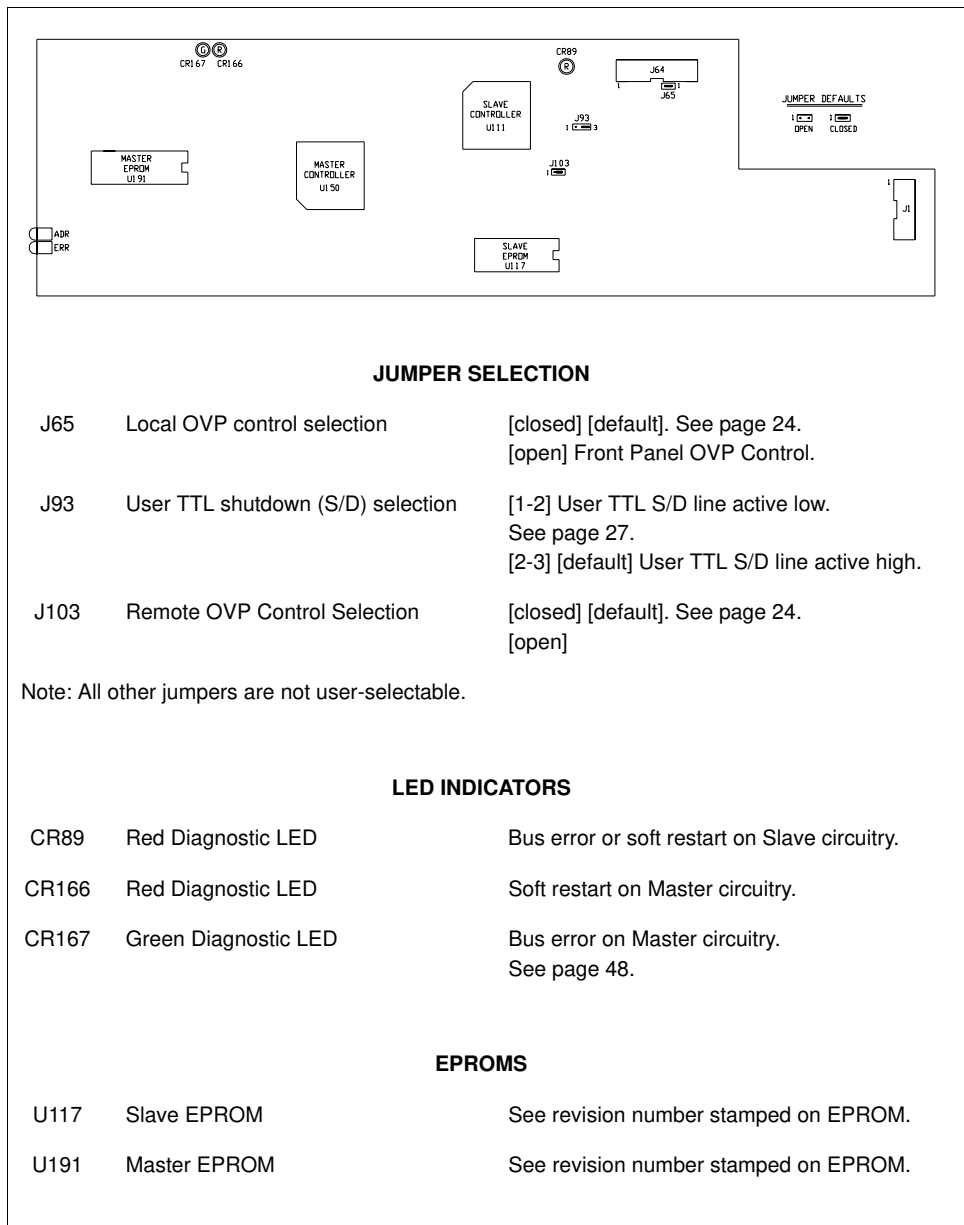

**Figure 2.3** GPIB Interface PCB

## Basic Setup Procedure

This procedure can be used as a quick reference for those familiar with the configuration requirements for the GPIB interface as installed in the DC power supply. For those who want more information, each step refers to more detailed procedures located in subsequent sections. Execute each step of the procedure in the sequence given.

**Table 2.1** Setup Procedure

Step #	Description	Action	Reference
1	Primary Address Selection	Use GPIB interface rear panel switches A1 to A5 to select a unique primary address. Setting the address identifies the power supply to the computer controller in a GPIB system.	See “IEEE-488 Primary Address Selection” on page 20
2	PON SRQ Selection	Use the rear panel SRQ switch to select the state of the Power ON Service Request	See “Power On Service Request (PON SRQ)” on page 21
3	Remote/Local Operation	Use the rear panel PON REM switch to select remote or local startup of the power supply.	See “Remote/Local Operation” on page 21
4	IEEE-488 Controller Connection	Connect the IEEE-488 bus to the supply at connector J8.	See “IEEE-488 Controller Connection” on page 24
5	Power ON	Power on the unit. Before proceeding, check to ensure that the green REM LED on the front panel is on.	See “Internal PCB Jumper Selections” on page 24 and “User Signals” on page 26 for information about Local/Remote OVP, TTL Shutdown, and auxiliary connector J7 user signals.
6	Configure Computer Controller	Configure the controller to match the power supply identification and characteristics using one of the available programs.	One such program is IBCONF (Interface Bus Configuration) from National Instruments. This program is used here as an example only.
7	Test	Test the link by communicating with the power supply.	Example: VSET2;ISET1 This command string sets power supply voltage to 2V and its current limit to 1A. Example: ibwrt "vset2;iset1" As above, using IBIC. *

\* This text uses National Instruments' IBIC (Interface Bus Interactive Control) program commands developed for their GPIB interface for computer controllers as examples only.

## Installation and Configuration

### IEEE-488 Primary Address Selection

#### IEEE-488 Primary Address Selection

1. Assign a primary address to each power supply: Choose a number between 0 and 30 which is unique to your IEEE-488 bus, that is, different from other device addresses on the same bus.
2. Locate switch S1 on the GPIB interface rear panel. See “GPIB Interface Subplate” on page 17 for the interface subplate drawing.
3. Use switch positions A1 to A5 to set the primary address for the power supply. See Table 2.2, “IEEE-488 Primary Address Selection”.

Switch 0 = (OFF, OPEN) Switch 1 = (ON, CLOSED)

**Table 2.2** IEEE-488 Primary Address Selection

Address	A5	A4	A3	A2	A1	Address	A5	A4	A3	A2	A1
0	0	0	0	0	0	16	1	0	0	0	0
1	0	0	0	0	1	17	1	0	0	0	1
2	0	0	0	1	0	18	1	0	0	1	0
3	0	0	0	1	1	19	1	0	0	1	1
4	0	0	1	0	0	20	1	0	1	0	0
5	0	0	1	0	1	21	1	0	1	0	1
6	0	0	1	1	0	22	1	0	1	1	0
7	0	0	1	1	1	23	1	0	1	1	1
8	0	1	0	0	0	24	1	1	0	0	0
9	0	1	0	0	1	25	1	1	0	0	1
10	0	1	0	1	0	26	1	1	0	1	0
11	0	1	0	1	1	27	1	1	0	1	1
12	0	1	1	0	0	28	1	1	1	0	0
13	0	1	1	0	1	29	1	1	1	0	1
14	0	1	1	1	0	30	1	1	1	1	0
15	0	1	1	1	1						

**Note:** Ensure you assign one address to each GPIB controller board as well.

## Power On Service Request (PON SRQ)

The Power ON Service Request (SRQ) switch is located on the GPIB subplate rear panel S1 switch. Enabling the SRQ switch causes the power supply to send a service request to the computer controller when the power supply is turned on or when it re-initializes after a momentary power interrupt. When the PON SRQ state is tripped, the front panel SRQ LED will also turn on. You can clear the service request and turn off the SRQ LED by performing a serial poll. See “Command Reference” on page 39 for information about the SRQ command. Table 2.3 shows the condition of the SRQ switch in relation to the position reference markings on the rear panel subplate. The location of the switch and reference markings can be found in Figure 2.2, “GPIB Interface Subplate” on page 17.

**Table 2.3** SRQ Switch Selection

Rear Panel SRQ Switch Position	PON SRQ State
0	PON SRQ Enabled
1	PON SRQ Disabled

## Remote/Local Operation

**Remote/Local Mode Startup** Start the power supply either in local mode or in remote mode by setting the power ON remote (PON REM) switch which is located on the unit’s rear panel. See Table 2.4 for the switch settings

**Table 2.4** Remote/Local Start-up Settings.

Switch Position	Power ON results
0	Unit in remote mode
1	Unit in local mode

With the rear panel PON REM switch set to 0, the power supply will start up in remote mode. The green REM LED on the front panel will turn on, signaling that the power supply is under the control of the digital interface card. The output of the power supply is active on startup. See Table 2.5 for more information. To promote load safety, power ON defaults are zero for the output voltage and current limit, and 110% of maximum output voltage for the OVP trip point. See Section 3, “Operation” for more information about the interface commands listed in the table.

## Installation and Configuration

### Remote/Local Operation

If the rear panel PON REM switch is set to 1, the power supply will power up in local mode. Power supply control is at the front panel. During an operating session, you can toggle between local mode and remote mode by using the front panel LOCAL button and sending commands as described in “Remote Mode Operation” on page 22 and “Local Mode Operation” on page 23.

**Table 2.5** Remote Mode Power On Conditions

Condition	Default Settings	7.5-140 Model Example
Voltage	0 V	VSET 0
Current	0 A	ISET 0
Soft Voltage Limit	VMAX (see models)	VMAX 7.5
Soft Current Limit	IMAX (see models)	IMAX 140
OVP Trip Voltage	Model VMAX + 10%	OVSET 8.25
Delay	0.5 s	DLY 0.5S
Foldback Protection	OFF	FOLD OFF
Output	ON	OUT ON
Hold	OFF	HOLD OFF
Unmask	NONE	UNMASK NONE
Service Request Capability	OFF	SRQ OFF
AUXA	OFF	AUXA OFF
AUXB	OFF	AUXB OFF

### Remote Mode Operation

While in remote mode, use the interface commands to control the output of the power supply from a computer. See Section 3, “Operation” for a complete list of device-dependent commands available with this interface. For information about how to use GPIB commands and GPIB lines, refer to the documentation for the particular GPIB controller interface installed on your computer.



While in remote mode, you can change to local mode operation by pressing the front panel LOCAL button, by sending the GPIB GTL (Go to Local) command, or by negating the GPIB REN (Remote Enable) line. You can disable the LOCAL button by enabling the GPIB Local Lockout (LLO) condition. For an example of how to use LLO, see “Setting Local Lockout”.

To return to remote mode, ensure that the REN line is asserted and then send any valid GPIB or device-dependent command. Since the remote mode output settings may be different from the local mode settings, the output is programmed to protect the load by turning off when you toggle from local to remote mode during a session. Check your remote settings and then send OUT ON to restore the output.

**Local Mode Operation**

In local mode operation, you set the voltage and current output levels and the OVP trip level with controls located on the front panel. Refer to the operating manual for a description of the functions available at the front panel.

While in local mode operation, you can change power supply control to remote mode by ensuring that the GPIB REN line is asserted and then sending any software command to get into remote mode and the OUT ON command to restore the output. You can return to local mode by pressing the front panel LOCAL button, unless Local Lockout is in effect. If LLO is in effect, use the GPIB GTL command to send the power supply into local mode, or negate the REN line to turn off LLO and return the power supply to local mode.

**Example:**

ibfind "devname"	Address the unit (devname or device name as configured originally with ibconf).
ibloc	Set unit to local mode.
ibwrt"id?"	Any message to the unit now puts it back to remote mode.
ibloc	Toggle back to local mode.

**Setting Local Lockout**

Use the GPIB Local Lockout command to disable the front panel LOCAL switch. With LLO in effect, you cannot return to local control by pressing the front panel LOCAL switch. You can still return to local mode by sending the GTL command. To turn off LLO and return the power supply to local mode, negate the REN line. The LLO condition can only be removed by negating the asserted REN line.

**Example:**

ibfind GPIB0	Address the computer controller
ibsic	Put the controller in charge by sending an Interface Clear.
ibsrcl	Assert the Remote Enable line.

## Installation and Configuration

### IEEE-488 Controller Connection

<code>ibfind GPIB0</code>	Address the computer controller
<code>ibcmd "?_@\x11"</code>	Send commands (UNL, UNT, MTA0, LLO) in ASCII.
<code>ibfind "devname"</code>	Address the unit (devname or device name as configured originally with <code>ibconf</code> ).
<code>ibloc</code>	Set unit to local mode.

**Note:** To disable Local Lockout, use the IBIC `ibsre0` command in this example.

## IEEE-488 Controller Connection

Use an approved IEEE-488 connector and cable when connecting the power supply's GPIB interface to your IEEE-488 GPIB network. The IEEE-488 connector uses mating connector J8 on the rear panel of the power supply.

## Internal PCB Jumper Selections



### CAUTION

If you remove the unit's cover, use proper static control techniques to avoid damage to static-sensitive components on the printed circuit board.

---

You can select how you use OVP (over voltage protection) control and TTL shutdown by changing jumper positions on the GPIB PCB. Refer to the operating manual for information on how to use over voltage protection and TTL shutdown.

### OVP Selection

Over voltage protection (OVP) on the GPIB interface is set at the factory for remote software operation. When operating the power supply in remote mode, you control the OVP trip level using the `OVSET` software command. If you return the power supply to local operation by using the GPIB software commands or the by the front panel LOCAL switch, control of the OVP trip level changes from software control to the front panel OVP potentiometer. The default OVP trip level is set as 110% of the power supply's rated output voltage. See Table 2.5, on page 22 for a complete list of remote power ON default settings.

You can isolate the location of OVP control by changing the positions of the Local OVP Control jumper J65 and the Remote OVP Control jumper J103. The default jumper settings allow control of OVP to depend on the operating state of the power supply. By physically changing the jumper settings, you can isolate the location of OVP control to software control only or front panel control only. Table 2.6, "OVP

Control Mode Selection” shows a table of jumper settings and OVP programming selection. Refer to “Basic Setup Procedure” on page 19 for the positions of the jumpers on the GPIB PCB.

**Table 2.6** OVP Control Mode Selection

<b>PCB Jumper J65 Position</b>	<b>PCB Jumper J103 Position</b>	<b>OVP Programming Selection</b>
Closed (default)	Closed (default)	Software or Front Panel OVP control (dependent on the power supply operating state)
Closed	Open	Software OVP control only
Open	Closed	Front Panel OVP control only
Open	Open	Front Panel OVP control only

## **TTL Shutdown**

You can use the Shutdown function to disable or enable the supply's output. Disabling the supply using TTL shutdown allows you to make adjustments to the load or to the power supply without shutting down the power supply. With the GPIB interface installed, TTL shutdown is activated by a TTL signal to Pin 1 of the J7 connector on the interface subplate. The shutdown user line uses a 0-5Vdc TTL input with a high signal range of 2.2-5.0Vdc. The current range of the shutdown line is 1-10mA. See Figure 2.5, “J7 User Signal Connector Circuit Block Diagram” on page 27 for a schematic of the J7 connector containing the shutdown user line.

You can select the logic level of the TTL input by changing the J93 connector on the GPIB PCB. Table 2.7 shows the TTL signal levels for the J93 jumper settings. See Figure 2.2-3 for the location of the J93 jumper on the printed circuit board.

**Table 2.7** Switch Settings for TTL Shutdown Circuit Logic

<b>PCB Jumper J93 Position</b>	<b>TTL Signal Level</b>	<b>Supply Output Condition</b>
Pin 2 to Pin 3 (default)	HIGH	OFF
	LOW	ON
Pin 1 to Pin 2	HIGH	ON
	LOW	OFF

## User Signals

### Connector J7 User Signals

Auxiliary connector J7, located on the GPIB interface rear panel, provides several signals to increase your operating control of the supply. These signals are dependent on the operator's design and uses. The operation of the J7 signal requires that you provide external Vcc and ground. Use a standard 8-position telephone jack and data cable to connect to J7. To locate the connector, refer to the GPIB interface subplate drawing in Figure 2.2, on page 21. See Figure 2.4, "User Signals J7 Connector" on page 26 for pin descriptions. The J7 outputs can sink a current of 5mA each. Figure 2.5, "J7 User Signal Connector Circuit Block Diagram" on page 27 shows the portion of the option board schematic which contains the J7 connector. Use the schematic as a reference when making input or output connections.

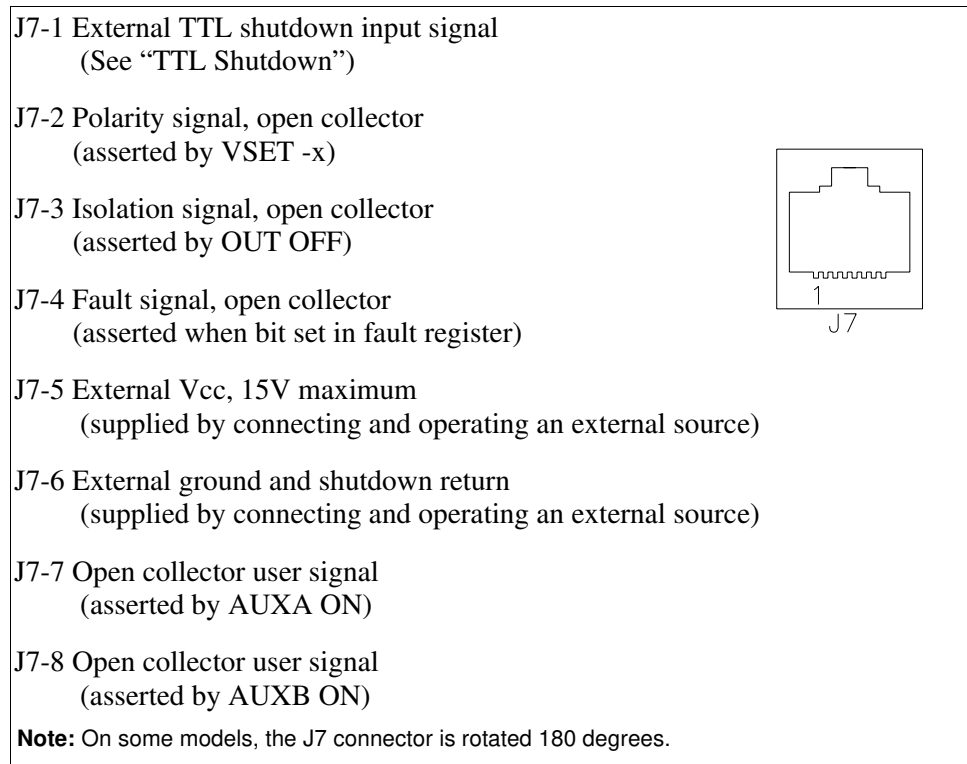

**Figure 2.4** User Signals J7 Connector

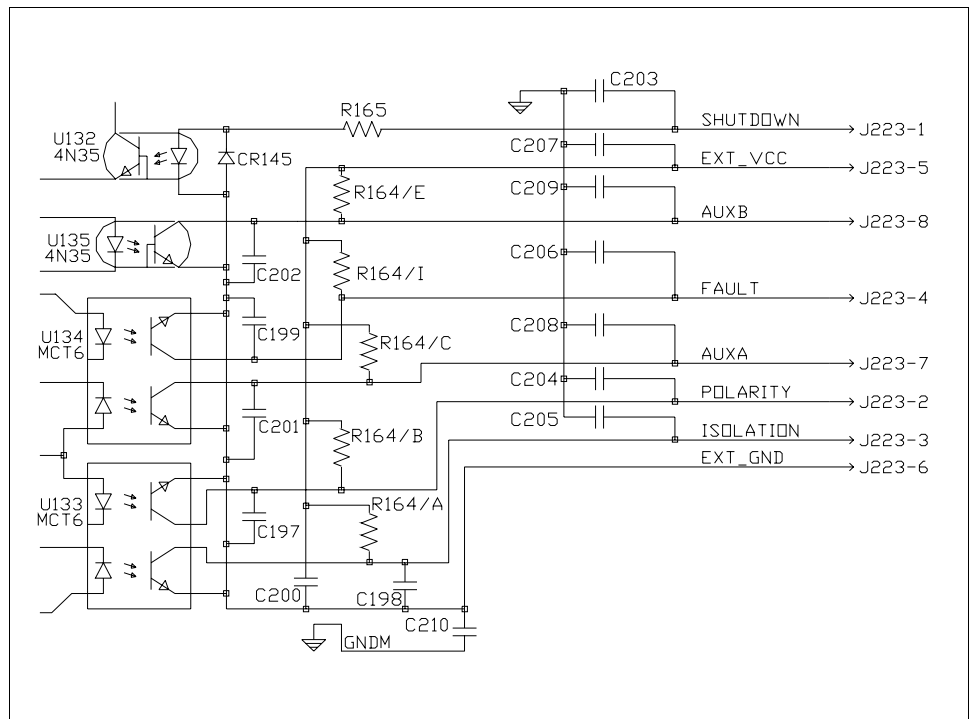

**Figure 2.5** J7 User Signal Connector Circuit Block Diagram

### J7 Cable Connection

Use a standard 8-position telephone jack and data cable to connect to J7. Add a ferrite block to reduce radiated emission. The one inch square ferrite block with built-in housing clip is packaged and shipped with the power supply interface card.

To install the ferrite block:

1. Position the block no more than 5 cm (2") from the power supply end of the J7 user cable.
2. Open the ferrite block housing.
3. Loop the cable through the ferrite block. See Figure 2.6, “J7 User Cable with Ferrite Block” on page 28.
4. Close the housing clip.

The ferrite block ensures that the power supply system meets radiated emission requirement 89/336/EEC for CE mark approval. See the power supply's operating manual for noise specifications.

## Installation and Configuration

### User Signals

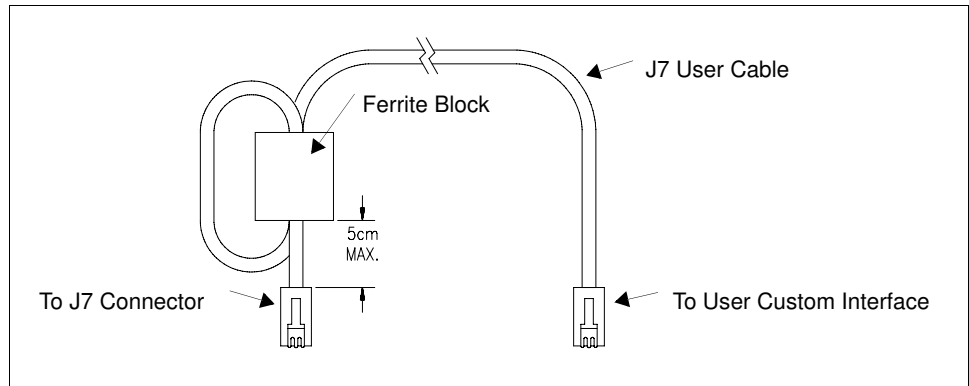

**Figure 2.6** J7 User Cable with Ferrite Block

# Section 3. Operation

## Introduction

This section covers GPIB interface programming, starting with IEEE-488 functions, continuing with an extensive set of device-dependent commands, and, finally, providing error codes, and status and fault register information.

## GPIB Operation

A GPIB interface controller card enables you to control an IEEE-488 bus system via computer, identifying which of its interconnected devices are to send and receive data. Interconnected devices could include programmable AC or DC power supplies, oscilloscopes, signal generators, digital voltmeters, universal counters, readouts, relays, and printers.

Use the GPIB interface to relay GPIB instructions from a computer controller to a power supply located at a selected IEEE-488 address and then to return responses from the power supply to the computer. You will also use the computer controller to issue device-dependent commands such as output voltage level and status queries.

**Note:** This text employs National Instruments' IBIC (Interface Bus Interactive Control) program commands developed for their GPIB interface for computer controllers as examples only.

**Table 3.1** IEEE-488.1 Interface Functions Implemented

	<b>Mnemonic</b>	<b>Capability</b>	<b>Description</b>
<b>Multiline Control Functions</b>	SH1	Source Handshake	Device must properly transfer a multiline message.
	AH1	Acceptor Handshake	Device must properly receive remote multiline messages.
	T6	Talker	Device must be able to transmit.
	L4	Listener	Device must receive commands and data.
<b>Interface Functions</b>	DC1	Device Clear	Device can be initialized to a previously determined state.
	DT1	Device Trigger	A device function can be initiated by a talker on the bus.
	E1	Open Collector Drivers	Describes the type of electrical drivers in a device.
	PP1	Parallel Poll	Upon controller request, device must uniquely identify itself if it requires service.
	RL1	Remote/Local	Device must be able to operate from front panel and via remote information from bus.
	SR1	Service Request	Device can asynchronously request service from controller.
	SP1	Serial Poll	All talkers on the bus assume a serial poll mode. Each device when addressed will provide an 8-bit word of status information.

**Multiline Control Functions** The GPIB interface and the computer controller implement the Acceptor Handshake, Source Handshake, Listener, and Talker functions. No user action is required. The unit's ADR (Addressed) LED turns on when the power supply is addressed to listen or talk.

**Device Clear** The power supply will implement Device Clear regardless of whether it is in local or remote control. Device Clear is typically used to send all or selected devices to a known state with a single command. The power supply will be set to Initial (Power On) Conditions after Device Clear.

**Example:**

<code>ibfind "devname"</code>	Address the unit (devname or device name as configured originally with <code>ibconf</code> )
<code>ibclr</code>	Low level command directed to entire bus, or
<code>ibwrt"clr"</code>	Device-dependent command directed to a specific device.



**Device Trigger** Device Trigger will implement the most recently programmed values whether the unit is in local or remote control. If the power supply is in local mode, the new values will be implemented when it is switched from local to remote control. Device Trigger is typically used to synchronize the operation of a number of addressed devices.

**Example:** Use HOLD Command to set values to be executed when triggered. See “Command Reference” on page 39.

Then use:.

ibfind "devname"	Address the unit (devname or device name as configured originally with ibconf)
ibtrg	Command directed to entire bus, or
ibwrt"trg"	Command directed to a specific device.

**Parallel Poll** Parallel Poll allows the computer controller to determine quickly which of a number of instruments on the bus requested service. The parallel poll response corresponds to bit 7 of the serial poll status byte. Parallel Poll does not reset the service request. The power supply must be configured remotely to respond to a parallel poll with either a "1" or "0" on one of the DIO lines if the unit is requesting service.

**Example:**

ibrpp	Conduct a parallel poll.
-------	--------------------------

**Local Lockout** Send Local Lockout from the computer controller to override the front panel LOCAL switch and ensure that the supply operates in remote mode. See “Setting Local Lockout” on page 23 for more information.

**Example:**

ibfind GPIB0	Address the computer controller
ibsic	Put the controller in charge by sending an Interface Clear
ibsre1	Asserts Remote Enable
ibcmd "?_@\x11"	Send commands (UNL, UNT, MTA0, LLO) in ASCII.

**Note:** To disable Local Lockout, use ibsre0 in place of ibsre1 in the example.

**Service Request** Service request is a uniline message asserted by the power supply at power on and for fault conditions. Ten (10) power supply conditions are defined as faults: CV, CC, OV, OTP, SD, FOLD, ERR, ACF, OPF, and SNSP. See “Accumulated Status, Status, and Fault Registers” on page 46 for more information. Power ON (PON) can also be flagged in the fault register if the supply's rear panel power on service request (PON SRQ) switch is set to ON. See “Power On Service Request (PON SRQ)” on page 21.

Enabling or disabling a condition from asserting service request does not affect the condition within the power supply, nor the external status indicators.

**Serial Poll** In a serial poll, the controller polls each device.

**Example:**

```
ibrsp           Return serial poll byte.
```

The power supply responds with a 8-bit status byte defined as follows:

**Table 3.2** Serial Poll Status Register

Bit Position	Decimal Weight	Description	Reset By
0 (LSB)	1	<b>Fault</b> - Set when any bit in the fault register is set by a fault condition in the supply. See also “Accumulated Status, Status, and Fault Registers” on page 46.	FAULT? query to reset
1	2	Not used	
2	4	Not used	
3	8	Not used	
4	16	<b>Ready</b> - Set when power supply is ready to accept commands.	Power supply, during command processing period
5	32	<b>Error (ERR)</b> - Set when ERR bit asserted in status register. See also “Accumulated Status, Status, and Fault Registers” on page 46.	ERR? query
6	64	<b>Request Service (SRQ)</b> - Set when power supply requests service.	Serial Poll
7 (MSB)	128	<b>Power On (PON)</b> - Set when unit initializes at power on.	CLR or Device Clear

## Command Syntax

**Manual Conventions** The manual uses these conventions when displaying command information. These characters are not part of the command but are used to denote parameters used with the command.

< > (angle brackets)	Angle brackets enclose a parameter. Do not include the angle brackets in the command line you send to the computer.
/ (slash)	Separates two alternative parameters. When a slash separates two parameters, you can use either parameter to achieve the same result. Example: <1/ON> Entering 1 or ON will achieve the same result.
COMPUTER ENTRY	Words typed on the computer are shown in Arial text, full capitals.

**Command Format and Parameters** The device-dependent language for the GPIB Interface consists of commands and parameters. A command is a one word code which either gives instructions to the interface or asks for information from the interface. A command may be followed by one or more parameters, a short code that changes the state of the power supply or the state of the bit register. Table 3.3, "Command Parameters" lists the parameters that affect the command set.

### Format:

COMMAND or  
COMMAND <parameter> or  
COMMAND <parameter>,<parameter>

- You can enter commands in upper or lower case lettering.  
Example: MASK FOLD = mask fold
- Do not further abbreviate command names or parameters.  
Example: MASK FOLD ≠ MK FOLD  
MASK FOLD ≠ MASK FD
- Use a space between the command and the first parameter. Any number of consecutive spaces is treated as one space. Numeric data may contain leading spaces. Embedded spaces between digits or between a digit and a decimal point are not accepted.  
Example: MASK FOLD = MASK FOLD  
VOUT 3.4 = VOUT 3.4  
VOUT 3.4 ≠ VOUT 3.4

**Operation**  
Command Syntax

- Use commas between parameters in those commands with more than one parameter, and between mnemonic parameters as in the MASK and UNMASK commands. Only one comma is allowed and it may be preceded or followed by any number of spaces.

Example: MASK CV, OV, FOLD

**Table 3.3** Command Parameters

Parameter	Description	Form
<current>, <lhi>, <llo>	The current in amps or milliamps. If no unit is given, the default unit is amps.	<float> <float>A <float>mA
<time>	The time in seconds or milliseconds. If no unit is given, the default unit is seconds.	<float> <float>s <float>ms
<voltage>, <Vlo>, <Vhi>	The voltage in volts or millivolts. If no unit is given, the default unit is volts.	<float> <float>V <float>mV
<mnemonics>	A combination of CV, CC, CV, OV, OT, SD, FOLD, ERR, PON, REM, ACF, OPF, and SNSP. See MASK and UNMASK commands in the command reference for use of the ALL and NONE parameters.	See registers on page 46.
<state>	The state of a binary condition.	<1/ON, 0/OFF>

**Floating Point Number <float>** Variables sent with command parameters are floating point numbers. Table 3.4 defines the structure of floating point numbers for use with the software commands.

**Table 3.4** Floating Point Numbers

Floating Number Definition	Example
The floating point number has four significant figures. It can be of either sign, positive or negative.	1.234 -1.234 +1.234
A floating point number can have one decimal point.	0.123 1.2 123.4
Scientific Notation	123.0E-1
Use E or e after the number for a base ten exponent.	1.2E-1
An integer of either sign must follow an exponent.	10.00E+1

**Command Strings** If you send more than one command line, separate the commands with a semicolon. The semicolon may be preceded or followed by spaces.

**Example:**

```
ISET 2.0A; VSET 5V
```

```
ISET 2.0A; VSET 5V
```

**Command Terminators** Terminators indicate the end of a command string and tell the power supply to execute the command. The termination character is LF (Line Feed).

**Format:**

```
COMMAND <parameter>; COMMAND <parameter>, <parameter><LF>
```

Most computer controllers automatically send LF with output statements.

**Order** You may send commands in any order, keeping in mind that only those commands received after a HOLD and before a TRG (trigger) will be released by the TRG command. In addition, only these commands received after a supply disable and before a RST (reset) or OUT ON command will be released by the RST command or the OUT command. Commands are executed in the order they are received.

## Command Summary

Use these commands to control the operation of the supply. They are listed here in order of function such as PROGRAMMING, QUERY, CALIBRATION, and STATUS commands. See “Command Reference” on page 39 for more detailed information about each command and its use.

**Table 3.5** Programming Commands

Command	Description
AUXA	Selects the state of the AUXA output signal on the J7-7 connector.
AUXB	Selects the state of the AUXB output signal on the J7-8 connector.
CLR	Initializes the power supply to its Power ON (PON) state.
DLY	Sets a programmable time delay which is executed by the supply before reporting fault conditions after a new output voltage or current is specified.
FOLD	Sets foldback mode for the supply.
HOLD	Enables or disables voltage/current setting hold mode for the supply.
IMAX	Sets an upper soft limit on the programmed output current for the supply.
ISET	Sets the output current of the supply in amps (default) or in milliamps.
OUT	Enables or disables voltage/current output for the supply.
OVSET	Sets the over voltage protection trip point for the supply in volts (default) or in millivolts.
RST	Resets the supply to the present voltage and current settings if the output is disabled by OVP or foldback protection.
SRQ	Enables or disables the power supply's ability to generate a service request.
TRG	Implements programmed voltage and current settings which had been in hold mode.
VMAX	Sets an upper soft limit on the supply's programmed output voltage.
VSET	Sets the output voltage of the power supply in volts (default) or in millivolts.

**Table 3.6** Query Commands

<b>Command</b>	<b>Description</b>
AUXA?	Asks for the state of the set value for the AUXA command
AUXB?	Asks for the state of the set value for the AUXB command
CMODE?	Asks for the power supply's calibration mode status.
DLY?	Asks for the programmable time delay setting before the supply reports fault conditions.
ERR?	Asks for the most recent remote programming error which occurred in the supply since the last time the error query command (ERR?) was used.
FOLD?	Asks for the supply's present foldback setting.
HOLD?	Asks for the present hold mode setting.
ID?	Asks for the power supply's model name and master EPROM version.
IMAX?	Asks for the supply's soft current limit setting.
IOUT?	Measures the supply's actual current output.
ISET?	Asks for the supply's present output current limit setting.
OUT?	Asks for the present enabled/disabled status of the supply's output.
OVSET?	Asks for the supply's present over voltage protection limit.
ROM?	Asks for the version number of the master and slave EPROMs on the interface PCB.
SRQ?	Asks for the present enabled/disabled status of the IEEE-488 Service Requests generated by the supply.
VMAX?	Asks for the supply's soft voltage limit setting.
VOUT?	Measures the supply's actual voltage output.
VSET?	Asks for the supply's present output voltage setting.

**Table 3.7** Calibration Commands

<b>Command</b>	<b>Description</b>
CMODE	Places the supply into calibration mode.
IDATA	Calculates the slope and intercept for current programming.
IHI	Sets the current output to the high calibration point.
ILO	Sets the current output to the low calibration point.
IRDAT	Calculates the slope and intercept for current readback.
IRHI	Sets the current output to the high readback point.
IRLO	Sets the current output to the low readback point.
OVCAL	Calibrates the over voltage protection (OVP).
VDATA	Calculates the slope and intercept for voltage programming.
VHI	Sets the voltage output to the high calibration point.
VLO	Sets the voltage output to the low calibration point.
VRDAT	Calculates the slope and intercept for voltage readback.
VRHI	Sets the voltage output to the high readback point.
VRLO	Sets the voltage output to the low readback point.

**Table 3.8** Status Commands

<b>Command</b>	<b>Description</b>
ASTS?	Asks for the supply's accumulated status register.
FAULT?	Asks for the supply's fault register for the status preset operating conditions.
MASK	Prevents the supply's previously unmasked operating conditions from setting bits in the fault register.
STS?	Asks for the supply's present status register.
UNMASK	Enables you to select those supply's operating conditions that you are most interested in monitoring for fault occurrence.
UNMASK?	Asks for the supply's fault conditions which are currently enabled (unmasked).



## Command Reference

**Table 3.9** Command Reference

Command	Description
ASTS?	Asks for the supply's accumulated status register. The accumulated status register stores any bit that was entered in the status register since the accumulated status query command (ASTS?) was last used, regardless of whether the condition still exists. The accumulated status register has the same bits, weights, and conditions as the status register. A bit in the accumulated status register will be set at 1 if the corresponding bit in the status register has been 1 (TRUE) at any time since the register was last read. See "Accumulated Status, Status, and Fault Registers" on page 46. The ASTS? query clears the status register. Response: ASTS <status mask> where status mask is the decimal equivalent of the total bit weights for the operating conditions as listed in the status register.
AUXA <1/ON>,<0/OFF>	Controls the AUXA output signal level at rear panel connector J7-7. Active low. Initial value: AUXA 0
AUXA?	Asks for the present set value of the AUXA output signal. Response: AUXA 0 (OFF) AUXA 1 (ON)
AUXB <1/ON>,<0/OFF>	Controls the AUXB output signal level at rear panel connector J7-8. Active low. Initial value: AUXB 0
AUXB?	Asks for the present set value of the AUXB output signal. Response: AUXB 0 (OFF) AUXB 1 (ON)
CLR	Initializes the power supply to its power ON condition. If issued while in local mode, CLR will force power supply settings to register default values as in but these default settings will not come into effect until the power supply is switched to remote mode operation. The CLR commands will clear faults from the fault register. CLR will not reset CMODE.
CMODE <1/ON>,<0/OFF>	CMODE ON places the power supply into calibration mode for processing calibration commands. Initial value: CMODE OFF or CMODE 0
CMODE?	Asks for the power supply's calibration mode status. Response: CMODE 0 (disabled) CMODE 1 (enabled)

## Operation

### Command Reference

Command	Description
DLY <seconds>	<p>Sets a programmable time delay employed by the supply before reporting fault conditions. The power supply uses the time delay after receiving a new output voltage or current setting via VSET or ISET, or after receiving RST, TRG, or OUT ON commands. During the time delay, the power supply disables CV, CC, and FOLD conditions from generating faults, preventing possible nuisance foldback if the supply momentarily switches modes while changing an output setting.</p> <p>Range: 0 to 32 seconds, with 32ms resolution Initial value: 0.5 second</p>
DLY?	<p>Asks for the setting of the programmable time delay before the supply reports fault conditions.</p> <p>Response: DLY &lt;seconds&gt;</p>
ERR?	<p>Asks for the most recent remote programming error. When the power supply detects a programming error, it lights the ERR LED and sets the ERR bit in the accumulated status and fault registers. If the error bit has been masked using the MASK command, then the ERR bit in the registers will not set. Once an error is detected, the remaining portion of the command line is discarded. An error query clears the ERR bit in the accumulated status register. See “Error Codes” on page 47.</p> <p>Response: ERR &lt;error number&gt; Example: ERR 0 (if no error)</p>
FAULT?	<p>Asks for the state of the fault register. A bit is set in the fault register when a fault arises for that condition. Lists the conditions which activate a fault bit. You can use the MASK command to disable bits from being set in the fault register.</p> <p>When a bit is set in the fault register it also asserts a signal on the J7-4 user signal line. You can tie the J7-4 fault line signal to the power supply's own External Shutdown user line, J7-1, so that the shutdown signal goes low (active) in the case of a user-defined fault.</p> <p>The FAULT? query clears bits in the supply's fault register and fault line.</p> <p>Response: FAULT &lt;fault mask&gt; where fault mask is the decimal equivalent of the total bit weights for the operating conditions as listed in the fault register. See “Accumulated Status, Status, and Fault Registers” on page 46.</p>
FOLD <2/CC>, <1/CV>, <0/OFF>	<p>Sets foldback mode for the supply. Foldback protection disables the power supply output when the output enters the fold condition. Reset with the RST command.</p> <p>Example: Specify FOLD 1 or FOLD CV (Constant Voltage) when you want the supply to operate in Constant Current mode and have foldback protection disable the output if the supply switches to Constant Voltage mode.</p> <p>Initial value: FOLD 0/OFF</p>

Command	Description
FOLD?	Asks for the supply's present foldback setting. Response: FOLD <mode> where mode is: 0 (OFF) or 1 (CV or Constant Voltage mode) or 2 (CC or Constant Current mode)
HOLD <1/ON>,<0/OFF>	Enables or disables voltage/current setting hold mode for the supply. When HOLD ON is specified, hold mode is enabled so that all voltage and current settings which would normally be implemented by the supply are held until a TRG (trigger) command is received. This feature allows you to synchronize the operation of several supplies. Initial value: HOLD OFF or HOLD 0
HOLD?	Asks for the present hold mode setting. Response: HOLD 0 (OFF or disabled) or HOLD 1 (ON or enabled)
ID?	Asks for the power supply model and the master EPROM version. Response: ID <model name><version>
IDATA <llo>,<lhi>	Calculates and records the slope and offset for programmed current using ILO and IHI data. Set CMODE ON before using this command. See also the calibration procedures in Section 4. <llo> and <lhi> are in <current> format.
IHI	In response to this command, the power supply sends a programmed current value to the output terminal. This value is at the high end of the power supply's current range and is read by an external device connected as part of the calibration procedure. Refer to this value as IHI and record it to use as input with the IDATA command. Set CMODE ON before using this command. See also the calibration procedures in Section 4.
ILO	In response to this command, the power supply sends a programmed current value to the output terminal. This value is at the low end of the power supply's current range and is read by an external device connected as part of the calibration procedure. Refer to this value as ILO and record it to use as input with the IDATA command. Set CMODE ON before using this command. See also the calibration procedures in Section 4 .
IMAX <current>	Sets an upper soft limit on the supply's programmed output current. If the soft limit is exceeded, or if the soft limit value is lower than the present output current setting, the supply will ignore the command, turn on the ERR LED, and set the ERR bit in the bit registers. Range: 0 to model maximum output current (IMAX) Initial value: model IMAX
IMAX?	Asks for the supply's soft current limit setting. Response: IMAX <current>
IOUT?	Measures the supply's actual current output using the built-in current readback circuitry. Response: IOUT <current>

## Operation

### Command Reference

Command	Description
IRDAT <llo>,<lhi>	Calculates and records the slope and offset for readback voltage using IRLO and IRHI data. Set CMODE ON before using this command. See also the calibration procedures in Section 4. <llo> and <lhi> are in <current> format.
IRHI	The power supply outputs a current value to an external device connected as part of the calibration procedure and records a current readback value internally. These values are at the high end of the programmed current range. Refer to the output value as IRHI and record it to use as input with the IRDAT command. Set CMODE ON before using this command. See also the calibration procedures in Section 4.
IRLO	The power supply outputs a current value to an external device connected as part of the calibration procedure and records a current readback value internally. These values are at the low end of the programmed current range. Refer to the output value as IRLO and record it to use as input with the IRDAT command. Set CMODE ON before using this command. See also the calibration procedures in Section 4.
ISSET <current>	Sets the power supply's output current in amps (default) or in milliamps. This programmed current is the actual output in CC mode or the current limit in CV mode. Range: 0 to model maximum output current (IMAX) Initial value: 0 amps
ISSET?	Asks for the supply's present output current setting. Does not apply to current settings which are being held. See HOLD command. Response: ISSET <current>
MASK <mnemonics>	Disables the supply's previously unmasked operating conditions from setting bits in the fault and status registers. See "Accumulated Status, Status, and Fault Registers" on page 46. Mnemonics are separated from each other by commas and may be sent in any order. Mnemonics: CV, CC, OV, OT, SD, FOLD, ERR, PON, REM, ACF, OPF, SNSP Note: UNMASK NONE = MASK ALL (Initial value) MASK NONE = UNMASK ALL
OUT <1/ON>,<0/OFF>	Enables or disables the supply's voltage/current output. The supply will continue to accept new commands while the output is disabled but these will not be implemented until OUT ON or OUT 1 is received. OUT ON is the default setting. When you start the supply in remote mode, the output is enabled. OUT OFF (or OUT 0) also sets the isolation signal on the rear panel J7 connector, line 3. You can use the to trip external relays to isolate the power supply from the load. Initial value: OUT ON (or OUT 1) for output enabled
OUT?	Asks for the present enabled/disabled status of the supply's output voltage/current. Response: OUT 1 output enabled or OUT 0 output disabled

Command	Description
OVCAL	Causes the master controller to perform automatic calibration of the supply's over voltage protection circuitry. Set CMODE ON before using this command. Ensure jumper J65 on the GPIB Interface PCB is connected for remote operation.
OVSET <voltage>	Sets the supply's over voltage protection trip point in volts (default) or in millivolts. If the trip point is exceeded, or if the trip point value is lower than the present output voltage setting, the supply will ignore the command, turn on the ERR LED, and set the ERR bit in the accumulated status register. Reset with the RST command. Range: 0 to 110% of model maximum output voltage (VMAX) Initial value: 110% of model VMAX
OVSET?	Asks for the supply's present over voltage protection limit. Response: OVSET <voltage>
ROM?	Asks for the version number of the master and slave EPROMs located on the interface PCB. Response: ROM M:<version> S:<version>
RST	Resets the supply to present voltage and current settings if the output is disabled by over voltage or foldback protection. Output values may be changed via VSET, ISET, and OVSET while the unit is disabled, but those values will not take effect until RST is applied.
SRQ <1/ON>,<0/OFF>	SRQ ON enables the supply to respond to a variety of fault conditions with a request for service to the IEEE-488 bus controller. With SRQ ON, the SRQ line will be asserted true whenever the FAU bit in the supply's serial poll register changes from 0 to 1. Therefore, the mask register, in addition to specifying which conditions set the FAU bit, also determines which conditions can generate service requests. Ten power supply conditions are defined as faults: CB, CC, OV, OTP, SD, ERR, FOLD, ACF, OPF, SNSP. Use the FAULT? query to discover which condition caused the service request. See "Accumulated Status, Status, and Fault Registers" on page 46. A request for service at Power ON (PON SRQ) is set via a rear panel switch on the supply. See "Power On Service Request (PON SRQ)" on page 21. SRQ remains disabled until the FAULT bit in the serial poll register is cleared by a FAULT? query.
SRQ?	Asks for the supply's present ability to generate service requests. Response: SRQ 0 (disabled) SRQ 1 (enabled)
STS?	Asks for the supply's present status register. Status conditions are stored in the status register. Each bit represents a separate condition. When the condition is true, the corresponding bit is 1 (true). Bits remain set in the status register as long as the condition is true. See "Accumulated Status, Status, and Fault Registers" on page 46. Response: STS <status mask> where status mask is the decimal equivalent of the total bit weights for the operating conditions as listed in the status register.

## Operation

### Command Reference

Command	Description
TRG	Implements programmed voltage and current settings which had been in hold mode. The supply operates with previous values until the TRG (trigger) command is sent.
UNMASK <mnemonics>	<p>Enables you to select the supply operating conditions that you are most interested in monitoring for fault occurrence. Mnemonics describing the conditions are separated from each other by commas, and may be sent in any order.</p> <p>Specifying one or more mnemonics which describe the conditions (or the decimal equivalent of their total bit weight) enables the selected conditions to set bits in the supply's fault and status registers during operation. A bit is set in the fault register when the corresponding bit in the status register changes from 0 to 1 and the corresponding bit in the mask register is 1. See "Accumulated Status, Status, and Fault Registers" on page 46.</p> <p>Mnemonics: CV, CC, OV, OT, SD, FOLD, ERR, PON, REM, ACF, OPF, SNSP, ALL, NONE</p> <p>Initial value: UNMASK NONE</p>
UNMASK?	<p>Asks for the supply's fault conditions which are currently enabled (unmasked).</p> <p>Response: UNMASK &lt;fault mask&gt; where fault mask is the decimal equivalent of the total bit weights for the operating conditions as listed in the status and fault registers See "Accumulated Status, Status, and Fault Registers" on page 46.</p>
VDATA <Vlo>,<Vhi>	<p>Calculates and records the slope and offset for programmed voltage using VLO and VHI data. Set CMODE ON before using this command. See also the calibration procedures in Section 4.</p> <p>&lt;Vlo&gt; and &lt;Vhi&gt; are in &lt;voltage&gt; format.</p>
VHI	<p>In response to this command, the power supply sends a programmed voltage value to the output terminal. This value is at the high end of the power supply's voltage range and is read by an external device connected as part of the calibration procedure. Refer to this value as VHI and record it to use as input with the VDATA command. Set CMODE ON before using this command. See also the calibration procedures in Section 4.</p>
VLO	<p>In response to this command, the power supply sends a programmed voltage value to the output terminal. This value is at the low end of the power supply's voltage range and is read by an external voltmeter connected as part of the calibration procedure. Refer to this value as VLO and record it to use as input with the VDATA command. Set CMODE ON before using this command. See also the calibration procedures in Section 4.</p>

Command	Description
VMAX <voltage>	Sets an upper soft limit on the supply's programmed output voltage. If the soft limit is exceeded, or if the soft limit value is lower than the present output voltage setting, the supply will ignore the command, turn on the ERR LED, and set the ERR bit in the accumulated status register. Range: 0 to model maximum output voltage (VMAX) Initial value: model VMAX
VMAX?	Asks for the supply's soft voltage limit setting. Response: VMAX <voltage>
VOUT?	Measures the supply's actual voltage output using the built-in voltage readback circuitry. Response: VOUT <voltage>
VRDAT <Vlo>,<Vhi>	Calculates and records the slope and offset for readback voltage using VRLO and VRHI data. Set CMODE ON before using this command. See also the calibration procedures in Section 4 . <Vlo> and <Vhi> are in <voltage> format.
VRHI	The power supply outputs a voltage value to an external voltmeter connected as part of the calibration procedure and records a voltage readback value internally. These values are at the high end of the programmed voltage range. Refer to the output value as VRHI and record it to use as input with the VRDAT command. Set CMODE ON before using this command. See also the calibration procedures in Section 4.
VRLO	The power supply outputs a voltage value to an external voltmeter connected as part of the calibration procedure and records a voltage readback value internally. These values are at the low end of the programmed voltage range. Refer to the output value as VRLO and record it to use as input with the VRDAT command. Set CMODE ON before using this command. See also the calibration procedures in Section 4.
VSET <voltage> or VSET <-voltage>	Sets the power supply's output voltage in volts (default) or in millivolts. This programmed voltage is the actual output in CV (constant voltage) mode or the voltage limit in CC (constant current) mode. If you enter a negative voltage value, the power supply will assert a signal on the J7-4 user signal line. You can use the user signal to trip external relays to switch the output polarity. Range: 0 to model maximum output voltage (VMAX) Initial value: 0 volts
VSET?	Asks for the power supply's present output voltage setting. Does not apply to voltage settings which are being held. See HOLD command. Response: VSET <voltage>





## Error Codes

If the ERR flag in the accumulated status or fault registers has been activated, an ERR? query will return an error number which corresponds to an event described in the following table. The ERR? query will also clear the ERR bit in the register.

**Table 3.11** Error Codes

ERROR #	ERROR IDENTIFICATION	EXPLANATION
0	No Errors	
4	Unrecognized Character	Received a character such as @, *, \$.
	Improper Number	Received a numeric character but the characters were not a proper number. Example: VSET, ±10.3
	Unrecognized String	Received an invalid command.
	Syntax Error	Received an incorrectly placed word, number, separator, or terminator. Example: OFF SRQ, VOUT 6, MASK, ERR
5	Number Out of Range	Specified a value for the command which was outside of the allowed range.
6	Attempt to Exceed Soft Limits	Attempted to program a voltage or current greater than the soft limit. Example: VMAX 500; VSET 550 LF
7	Improper Soft Limit	Attempted to program a soft limit less than the output value.
8	Data Requested without a Query Being Sent	The controller requested data from the power supply without first sending a query command.
9	OVP Set Below Output	Sent an OVSET command with a trip value lower than the output voltage.
10	Slave Processor Not Responding	The interface PCB slave processor did not respond.
12	Illegal Calibration	Attempted calibration when the supply was not in calibration mode. See CMODE command.

## Troubleshooting



### WARNING

Exercise caution when using and servicing power supplies. High energy levels can be stored at the output voltage terminals on all power supplies in normal operation. In addition, potentially lethal voltages exist in the power circuit and the output connector of power supplies which are rated at 40V and over. Filter capacitors store potentially dangerous energy for some time after power is removed.

---

### Diagnostic LEDs

This section describes the diagnostic LEDs found on the GPIB interface.

**Computer Operating Properly (COP) LEDs** The GPIB interface provides three diagnostic LEDs, located at CR167, CR166, and CR89 on its PCB. Refer to Figure 2.3, ‘GPIB Interface PCB’ on page 18, for their locations. At present, these LEDs turn on to signal COP events for the interface's microprocessors. Issue a RST (reset) command to turn off the diagnostic LEDs.

The green COP LED at circuit designation CR167 indicates that the GPIB interface microprocessor successfully recovered from an illegal operating code. The event is transparent to the GPIB communications bus and the GPIB interface continues to function normally.

The red COP LED at CR166 indicates that a transparent restart caused by noise in the master processor circuitry has occurred.

The red COP LED at CR89 indicates that a transparent restart caused by noise in the slave processor circuitry has occurred.

# Section 4. Calibration

## Introduction



### WARNING

Exercise caution when using and servicing power supplies. High energy levels can be stored at the output voltage terminals on all power supplies in normal operation. In addition, potentially lethal voltages exist in the power circuit and the output connector of power supplies which are rated at 40V and over. Filter capacitors store potentially dangerous energy for some time after power is removed.

---

You can calibrate the GPIB interface by adjusting the signal levels on the interface card so that they correspond to the expected signal levels on the power supply's main assembly. You may need to recalibrate the interface if you replace parts either on the interface board or on the main power supply board, or if the unit falls out of specification due to component aging drifts.

You can calibrate the GPIB Interface for:

- Voltage program
- Voltage readback
- Current program
- Current readback
- Overvoltage protection

The following equipment will be required to accurately calibrate your unit:

- Digital Voltmeter, 5 1/2 digit, 0.1% accuracy or better, with test leads
- Current sensing shunt resistor, rated for 150% of maximum output current, 0.25% accuracy or better
- Connection wires rated for the unit's maximum output current and voltage
- A GPIB equipped computer to send the calibration commands to the unit

Calibrate the unit according to the following procedures, referring to “Command Reference” for more information about the calibration commands used.

The calibration procedures in this section are designed to be performed at an ambient temperature of  $25^{\circ}\text{C} \pm 5^{\circ}\text{C}$ .

## Calibration

### Voltage Mode Calibration

## Voltage Mode Calibration

### Voltage Calibration Setup

1. Disconnect the load from the power supply which is to be calibrated.
2. Connect a voltmeter across the power supply's output terminals.

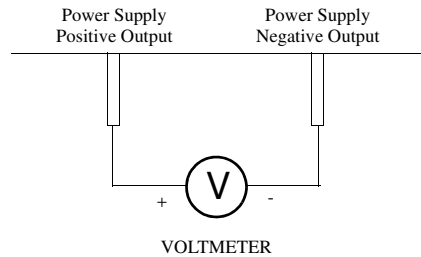

**Figure 4.1** Voltage Calibration Setup

### Voltage Program Calibration Procedure

1. Set the power supply for calibration as in Figure 4.1.
2. Activate calibration mode by sending command `CMODE ON` or `CMODE 1` to the power supply.
3. Send command `VLO; ILO` to the power supply. Measure and record the output shown on the external voltmeter.
4. Send command `VHI; IHI` to the supply. Measure and record the output voltage as shown on the external voltmeter.
5. Send the command `VDATA <vlo>,<vhi>` where `<vlo>` and `<vhi>` are the values read from the voltmeter when the `VLO` and `VHI` commands were sent. When the power supply is calibrated, the low to high voltage program calibration values are stored as constants.
6. Program the supply at various levels using the `VSET` command to confirm that the calibration was successful and that linearity is observed. See the voltage program accuracy specification in Section 1.
7. Turn off calibration mode by sending the command `CMODE OFF` or `CMODE 0` to the power supply.

### Voltage Readback Calibration Procedure

1. Set the power supply for calibration as in Figure 4.1.
2. Activate calibration mode by sending command `CMODE ON` or `CMODE 1` to the power supply.

3. Send command VRLO; IRLO to the power supply. Wait for the supply to settle. Measure and record the output shown on the external voltmeter. Send VRLO again.
4. Send VRHI; IRHI to the supply. Wait for the supply to settle. Measure and record the output voltage shown on the external voltmeter. Send VRHI again.
5. Send the command VRDAT <vlo>,<vhi> where <vlo> and <vhi> are the values read from the voltmeter after the VRLO and VRHI commands were sent. The processor calculates the offset value required to calibrate the power supply. When the power supply is calibrated, the low to high voltage readback calibration values (offsets) are stored as constants.
6. Use commands VSET and VOUT? commands to confirm that the calibration was successful and that linearity is observed. Refer to the voltage readback accuracy specification in Section 1.
7. Turn off calibration mode by sending the command CMODE OFF or CMODE 0 to the power supply.

## Calibration

### Current Mode Calibration

## Current Mode Calibration

### Current Calibration Setup

1. Disconnect the load from the power supply to be calibrated.
2. Connect a shunt across the supply's output terminals.
3. Connect a voltmeter across the shunt.

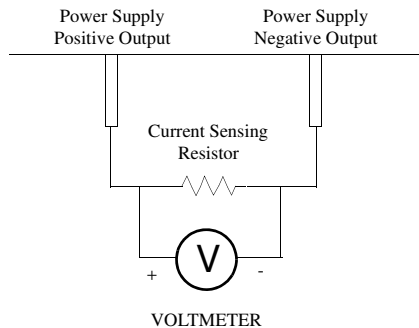

**Figure 4.2** Current Calibration Setup

### Current Program Calibration Procedure

1. Connect the shunt and voltmeter to the power supply as shown in Figure 4.2.
2. Activate calibration mode by sending command `CMODE ON` or `CMODE 1` to the power supply.
3. Send command `ILO; VLO` to the power supply. Measure and record the output shown on the external voltmeter.
4. Send command `IHI; VHI` to the supply. Measure and record the output voltage shown on the external voltmeter.
5. Calculate `ILO` and `IHI` from the voltages read from the external voltmeter and the shunt resistance.  $I = V/R$ .
6. Send the command `IDATA <ilo>, <ihi>` to the power supply. `<ilo>` and `<ihi>` are the current values obtained from sending the `ILO` and `IHI` commands to the power supply. When the power supply is calibrated, the low to high current program calibration values are stored as constants.
7. Program the supply at various levels using the `ISET` command to confirm that the calibration was successful and that linearity is observed. Refer to the current program accuracy specification in Section 1.
8. Turn off calibration mode by sending the command `CMODE OFF` or `CMODE 0` to the power supply.

**Current  
Readback  
Calibration  
Procedure**

1. Connect the current shunt and voltmeter to the power supply as shown in Figure 4.2.
2. Activate calibration mode by sending command CMODE ON or CMODE 1 to the power supply.
3. Send command IRLO; VRLO to the power supply. Wait for the supply to settle. Measure and record the output voltage shown on the external voltmeter. Send IRLO again.
4. Send command IRHI; VRHI to the supply. Wait for the supply to settle. Measure and record the output voltage shown on the external voltmeter. Send IRHI again.
5. Calculate IRLO and IRHI from the voltages taken from the external voltmeter and the shunt resistance.  $I=V/R$ .
6. Send the command IRDAT <ilo>,<ihi> to the power supply. <ilo> and <ihi> are the current values obtained from sending the IRLO and IRHI commands to the power supply. When the power supply is calibrated, the low to high current readback calibration values are stored as constants.
7. Program the supply at various levels using the ISET command to confirm that the calibration was successful and that linearity is observed. Refer to the current readback accuracy specification in Section 1.
8. Turn off calibration mode by sending the command CMODE OFF or CMODE 0 to the power supply.

## Calibration

### Over Voltage Protection (OVP) Calibration

## Over Voltage Protection (OVP) Calibration

We recommend that you perform OVP calibration every six months. Connecting a digital voltmeter as in “Voltage Calibration Setup” is optional.

1. Disconnect all loads from the power supply.
2. Ensure that jumper J65 on the interface PCB is CLOSED to enable remote OVP calibration (Jumper J65 is closed at the factory). See for the location on the PCB of jumper J65.
3. Activate calibration mode by sending command CMODE ON or CMODE 1 to the power supply.
4. Send the command OVCAL to the power supply. The ADR LED will light during OVP calibration. Calibration is complete when the ADR LED turns off. This may take a few minutes.
5. Use the OVSET, OVSET?, and VSET commands to trip the OVP level, confirming that the calibration was successful. When you trip the OVP level, the red OVP LED will light and the voltage will drop to zero. Send the command RST to clear the OVP condition. Refer to the OVP program accuracy specification in Section 1.
6. Turn off calibration mode by sending the command CMODE OFF or CMODE 0 to the power supply.



# Warranty and Return Information

## Warranty

### What does this warranty cover?

This Limited Warranty is provided by Xantrex Technology Inc. ("Xantrex") and covers defects in workmanship and materials in your Internal GPIB Interface for XHR and XFR Series Programmable DC Power Supplies. This warranty period lasts for five (5) years from the date of purchase at the point of sale to you, the original end user customer. You require proof of purchase to make warranty claims.

### What will Xantrex do?

Xantrex will, at its option, repair or replace the defective product free of charge, provided that you notify Xantrex of the product defect within the Warranty Period, and provided that Xantrex through inspection establishes the existence of such a defect and that it is covered by this Limited Warranty.

Xantrex will, at its option, use new and/or reconditioned parts in performing warranty repair and building replacement products. Xantrex reserves the right to use parts or products of original or improved design in the repair or replacement. If Xantrex repairs or replaces a product, its warranty continues for the remaining portion of the original Warranty Period or 90 days from the date of the return shipment to the customer, whichever is greater. All replaced products and all parts removed from repaired products become the property of Xantrex.

Xantrex covers both parts and labor necessary to repair the product, and return shipment to the customer via a Xantrex-selected non-expedited surface freight within the contiguous United States and Canada. Alaska and Hawaii are excluded. Contact Xantrex Customer Service for details on freight policy for return shipments outside of the contiguous United States and Canada.

### How do you get service?

If your product requires troubleshooting or warranty service, contact your merchant. If you are unable to contact your merchant, or the merchant is unable to provide service, contact Xantrex directly at:

Telephone: 1 800 733 5427(toll free North America)  
1 858 450 0085 (direct)  
Fax: 1 858 678 4482 (direct)  
Email: prg.info@xantrex.com

Direct returns may be performed according to the Xantrex Return Material Authorization Policy described in your product manual. For some products, Xantrex maintains a network of regional Authorized Service Centers. Call Xantrex or check our website to see if your product can be repaired at one of these facilities.

### What proof of purchase is required?

In any warranty claim, dated proof of purchase must accompany the product and the product must not have been disassembled or modified without prior written authorization by Xantrex.

Proof of purchase may be in any one of the following forms:

- The dated purchase receipt from the original purchase of the product at point of sale to the end user, or
- The dated dealer invoice or purchase receipt showing original equipment manufacturer (OEM) status, or
- The dated invoice or purchase receipt showing the product exchanged under warranty

## What does this warranty not cover?

This Limited Warranty does not cover normal wear and tear of the product or costs related to the removal, installation, or troubleshooting of the customer's electrical systems. This warranty does not apply to and Xantrex will not be responsible for any defect in or damage to:

- a) the product if it has been misused, neglected, improperly installed, physically damaged or altered, either internally or externally, or damaged from improper use or use in an unsuitable environment;
- b) the product if it has been subjected to fire, water, generalized corrosion, biological infestations, or input voltage that creates operating conditions beyond the maximum or minimum limits listed in the Xantrex product specifications including high input voltage from generators and lightning strikes;
- c) the product if repairs have been done to it other than by Xantrex or its authorized service centers (hereafter "ASCs");
- d) the product if it is used as a component part of a product expressly warranted by another manufacturer;
- e) the product if its original identification (trade-mark, serial number) markings have been defaced, altered, or removed.

## Disclaimer

### Product

THIS LIMITED WARRANTY IS THE SOLE AND EXCLUSIVE WARRANTY PROVIDED BY XANTREX IN CONNECTION WITH YOUR XANTREX PRODUCT AND IS, WHERE PERMITTED BY LAW, IN LIEU OF ALL OTHER WARRANTIES, CONDITIONS, GUARANTEES, REPRESENTATIONS, OBLIGATIONS AND LIABILITIES, EXPRESS OR IMPLIED, STATUTORY OR OTHERWISE IN CONNECTION WITH THE PRODUCT, HOWEVER ARISING (WHETHER BY CONTRACT, TORT, NEGLIGENCE, PRINCIPLES OF MANUFACTURER'S LIABILITY, OPERATION OF LAW, CONDUCT, STATEMENT OR OTHERWISE), INCLUDING WITHOUT RESTRICTION ANY IMPLIED WARRANTY OR CONDITION OF QUALITY, MERCHANTABILITY OR FITNESS FOR A PARTICULAR PURPOSE. ANY IMPLIED WARRANTY OF MERCHANTABILITY OR FITNESS FOR A PARTICULAR PURPOSE TO THE EXTENT REQUIRED UNDER APPLICABLE LAW TO APPLY TO THE PRODUCT SHALL BE LIMITED IN DURATION TO THE PERIOD STIPULATED UNDER THIS LIMITED WARRANTY.

IN NO EVENT WILL XANTREX BE LIABLE FOR ANY SPECIAL, INDIRECT, INCIDENTAL OR CONSEQUENTIAL DAMAGES, LOSSES, COSTS OR EXPENSES HOWEVER ARISING WHETHER IN CONTRACT OR TORT INCLUDING WITHOUT RESTRICTION ANY ECONOMIC LOSSES OF ANY KIND, ANY LOSS OR DAMAGE TO PROPERTY, ANY PERSONAL INJURY, ANY DAMAGE OR INJURY ARISING FROM OR AS A RESULT OF MISUSE OR ABUSE, OR THE INCORRECT INSTALLATION, INTEGRATION OR OPERATION OF THE PRODUCT.

### Exclusions

If this product is a consumer product, federal law does not allow an exclusion of implied warranties. To the extent you are entitled to implied warranties under federal law, to the extent permitted by applicable law they are limited to the duration of this Limited Warranty. Some states and provinces do not allow limitations or exclusions on implied warranties or on the duration of an implied warranty or on the limitation or exclusion of incidental or consequential damages, so the above limitation(s) or exclusion(s) may not apply to you. This Limited Warranty gives you specific legal rights. You may have other rights which may vary from state to state or province to province.

## Warning: Limitations On Use

Please refer to your product manual for limitations on uses of the product.

SPECIFICALLY, PLEASE NOTE THAT THE INTERNAL GPIB INTERFACE FOR XHR AND XFR SERIES PROGRAMMABLE DC POWER SUPPLIES SHOULD NOT BE USED IN CONNECTION WITH LIFE SUPPORT SYSTEMS OR OTHER MEDICAL EQUIPMENT OR DEVICES. WITHOUT LIMITING THE GENERALITY OF THE FOREGOING, XANTREX MAKES NO REPRESENTATIONS OR WARRANTIES REGARDING THE USE OF THE XANTREX INTERNAL GPIB INTERFACE FOR XHR AND XFR SERIES PROGRAMMABLE DC POWER SUPPLIES IN CONNECTION WITH LIFE SUPPORT SYSTEMS OR OTHER MEDICAL EQUIPMENT OR DEVICES.

## Return Material Authorization Policy

Before returning a product directly to Xantrex you must obtain a Return Material Authorization (RMA) number and the correct factory "Ship To" address. Products must also be shipped prepaid. Product shipments will be refused and returned at your expense if they are unauthorized, returned without an RMA number clearly marked on the outside of the shipping box, if they are shipped collect, or if they are shipped to the wrong location.

When you contact Xantrex to obtain service, please have your instruction manual ready for reference and be prepared to supply:

- The serial number of your product
- Information about the installation and use of the unit
- Information about the failure and/or reason for the return
- A copy of your dated proof of purchase

Record these details in "Information About Your System" on page 5–58.

## Return Procedure

1. Package the unit safely, preferably using the original box and packing materials. Please ensure that your product is shipped fully insured in the original packaging or equivalent. This warranty will not apply where the product is damaged due to improper packaging.
2. Include the following:
  - The RMA number supplied by Xantrex Technology Inc. clearly marked on the outside of the box.
  - A return address where the unit can be shipped. Post office boxes are not acceptable.
  - A contact telephone number where you can be reached during work hours.
  - A brief description of the problem.
3. Ship the unit prepaid to the address provided by your Xantrex customer service representative.

### **If you are returning a product from outside of the USA or Canada**

In addition to the above, you MUST include return freight funds and are fully responsible for all documents, duties, tariffs, and deposits.

### **If you are returning a product to a Xantrex Authorized Service Center (ASC)**

A Xantrex return material authorization (RMA) number is not required. However, you must contact the ASC prior to returning the product or presenting the unit to verify any return procedures that may apply to that particular facility.

## Out of Warranty Service

If the warranty period for your Internal GPIB Interface for XHR and XFR Series Programmable DC Power Supplies has expired, if the unit was damaged by misuse or incorrect installation, if other conditions of the warranty have not been met, or if no dated proof of purchase is available, your inverter may be serviced or replaced for a flat fee.

To return your Internal GPIB Interface for XHR and XFR Series Programmable DC Power Supplies for out of warranty service, contact Xantrex Customer Service for a Return Material Authorization (RMA) number and follow the other steps outlined in “Return Procedure” on page 5–57.

Payment options such as credit card or money order will be explained by the Customer Service Representative. In cases where the minimum flat fee does not apply, as with incomplete units or units with excessive damage, an additional fee will be charged. If applicable, you will be contacted by Customer Service once your unit has been received.

## Information About Your System

As soon as you open your Internal GPIB Interface for XHR and XFR Series Programmable DC Power Supplies package, record the following information and be sure to keep your proof of purchase.

- Serial Number \_\_\_\_\_
- Purchased From \_\_\_\_\_
- Purchase Date \_\_\_\_\_



**Xantrex Technology Inc.**

858 450 0085 Tel

858 678 4482 Fax

800 733 5427 Toll Free North America

[prg.info@xantrex.com](mailto:prg.info@xantrex.com)

[www.xantrex.com](http://www.xantrex.com)

TM-GPRF-01XN

PRINTED IN USA