

Smart choice for power

**xantrex**



**XFR 7.5-300**  
**XFR 12-220**  
**XFR 20-130**  
**XFR 33-85**  
**XFR 40-70**  
**XFR 60-46**  
**XFR 100-28**  
**XFR 150-18**  
**XFR 300-9**  
**XFR 600-4**

**Operating Manual**

# **XFR 2800 Watt Series Programmable DC Power Supply**

[www.xantrex.com](http://www.xantrex.com)



# **XFR 2800 Watt Series Programmable DC Power Supply**

## **Operation Manual**

## **About Xantrex**

Xantrex Technology Inc. is a world-leading supplier of advanced power electronics and controls with products from 50 watt mobile units to one MW utility-scale systems for wind, solar, batteries, fuel cells, microturbines, and backup power applications in both grid-connected and stand-alone systems. Xantrex products include inverters, battery chargers, programmable power supplies, and variable speed drives that convert, supply, control, clean, and distribute electrical power.

## **Trademarks**

Xantrex is a registered trademark of Xantrex International.

Other trademarks, registered trademarks, and product names are the property of their respective owners and are used herein for identification purposes only.

## **Notice of Copyright**

XFR 2800 Watt Series Programmable DC Power Supply Operation Manual© October 2007 Xantrex Technology Inc. All rights reserved.

## **Disclaimer**

UNLESS SPECIFICALLY AGREED TO IN WRITING, XANTREX TECHNOLOGY INC. ("XANTREX")

(a) MAKES NO WARRANTY AS TO THE ACCURACY, SUFFICIENCY OR SUITABILITY OF ANY TECHNICAL OR OTHER INFORMATION PROVIDED IN ITS MANUALS OR OTHER DOCUMENTATION.

(b) ASSUMES NO RESPONSIBILITY OR LIABILITY FOR LOSS OR DAMAGE, WHETHER DIRECT, INDIRECT, CONSEQUENTIAL OR INCIDENTAL, WHICH MIGHT ARISE OUT OF THE USE OF SUCH INFORMATION. THE USE OF ANY SUCH INFORMATION WILL BE ENTIRELY AT THE USER'S RISK.

## **Date and Revision**

October 2007 Revision B

## **Part Number**

TM-F2OP-C1XN-01

## **Contact Information**

Telephone: 1 800 733 5427 (toll free North America)  
1 858 450 0085 (direct)

Fax: 1 858 678 4482 (direct)

Email: [prg.info@xantrex.com](mailto:prg.info@xantrex.com)

Web: [www.xantrex.com](http://www.xantrex.com)

# About This Manual

## Purpose

This Operation Manual contains installation and operating information for the XFR 2800 Watt Series Programmable DC Power Supply.

## Scope

The Manual provides safety guidelines, information on features and specifications, installation procedures, and basic functions testing, as well as operating procedures for using both front panel control and remote analog programming functions.

## Audience

This manual is designed for the user who is familiar with basic electrical theory, especially as they apply to the operation of power supplies. This implies a recognition of Constant Voltage and Constant Current operating modes and the control of input and output power, as well as the observance of safe techniques while making supply or pin connections and any changes in switch settings.

## Organization

This Manual is organized into four chapters and one appendix.

“Features and Specifications”, Chapter 1 describes the XFR 2800 Watt Series Programmable DC Power Supply and lists the features.

“Installation”, Chapter 2 provides recommendations and procedures for inspecting, installing, and testing the power supply.

“Local Operation”, Chapter 3 provides procedures for local (front panel) operation. It includes procedures for using over voltage protection, shutdown function, multiple supplies, and over temperature protection.

“Remote Operation”, Chapter 4 details remote analog programming operation and remote monitoring of output voltage and current.

“Calibration and Troubleshooting”, Chapter 5 details remote analog programming operation and remote monitoring of output voltage and current. It also provides troubleshooting information.

“Specifications”, Appendix A contains electrical, mechanical and environmental specifications and characteristics of the XFR 2800 Watt Series Programmable DC Power Supply.

## Conventions Used

The following conventions are used in this guide.



### **WARNING**

Warnings identify conditions or practices that could result in personal injury or loss of life.



### **CAUTION**

Cautions identify conditions or practices that could result in damage to the unit or other equipment.

---

**Important:** These notes describe things which are important for you to know, but not as serious as a caution or warning.

---

## Related Information

You can find more information about Xantrex Technology Inc. as well as its products and services at [www.xantrex.com](http://www.xantrex.com)

# Important Safety Instructions



## **WARNING: High energy and high voltage**

Exercise caution when using and calibrating a power supply. High energy levels can be stored at the output voltage terminals on a power supply in normal operation. In addition, potentially lethal voltages exist in the power circuit and on the output and sense connectors of a power supply with a rated output greater than 40 V. Filter capacitors store potentially dangerous energy for some time after power is removed.



## **CAUTION**

Operate the power supply in an environment free of flammable gases or fumes. To ensure that the power supply's safety features are not compromised, use the power supply as specified in this manual and do not substitute parts or make any unauthorized modifications. Contact the service technician for service and repair help. Repairs must be made by experienced service technicians only.



## **CAUTION: For use as a battery charger**

When you are using any of these power supplies for battery charging applications, it is essential to provide an appropriately sized fuse or circuit breaker in series between the power supply output and the battery. Installation of a protector (fuse or DC circuit breaker) rated for about 115% of the maximum current rating of the power supply and designed specifically to interrupt the DC voltage of the battery, will provide adequate reverse polarity current protection. Where several power supplies are in parallel, it is best to fuse each one, rather than one large fuse for all.

## Power Supply Safety Markings



Alternating Current



Earth (Ground) Terminal



Protective Conductor Terminal



Off (Supply)



On (Supply)



Caution (Check manual for additional information.)

## Standard Warnings

---



### **WARNING**

This chapter contains important safety and operating instructions. Read and keep this Operation Manual for future reference.

---

1. Before installing and using the XFR 2800 Watt Series Programmable DC Power Supply, read all instructions and cautionary markings on the XFR and all appropriate sections of this guide.
2. Do not expose the XFR to rain, snow, spray, or bilge water. To reduce risk of fire hazard, do not cover or obstruct the ventilation openings. Do not install the XFR in a zero-clearance compartment. Overheating may result.
3. Use only attachments recommended or sold by the manufacturer. Doing otherwise may result in a risk of fire, electric shock, or injury to persons.
4. To avoid a risk of fire and electric shock, make sure that existing wiring is in good condition and that wire is not undersized. Do not operate the XFR with damaged or substandard wiring.
5. Do not operate the XFR if it has received a sharp blow, been dropped, or otherwise damaged in any way. If the XFR is damaged, see the Warranty section.
6. Do not disassemble the XFR. It contains no user-serviceable parts. See Warranty for instructions on obtaining service. Attempting to service the XFR yourself may result in a risk of electrical shock or fire. Internal capacitors remain charged after all power is disconnected.
7. To reduce the risk of electrical shock, disconnect both AC power from the XFR before attempting any maintenance or cleaning or working on any circuits connected to the XFR. Turning off controls will not reduce this risk.



# Contents

<b>Important Safety Instructions</b> .....	v
--	---

## 1 Features and Specifications

Description .....	1-2
Features and Options .....	1-3
Front Panel Controls .....	1-3
Rear Panel Connectors and Switch .....	1-5
Rear Panel SW1 Switch .....	1-6
Resetting the Switches .....	1-7
Rear Panel J2 Connector .....	1-7
Making J2 Connections .....	1-9
Wiring .....	1-9

## 2 Installation

Basic Setup Procedure .....	2-2
Inspection, Cleaning, and Packaging .....	2-3
Initial Inspection .....	2-3
Periodic Cleaning .....	2-3
Packaging for Shipping or Storage .....	2-3
Location, Mounting, and Ventilation .....	2-4
Rack Mounting .....	2-4
Ventilation .....	2-5
AC Input Power .....	2-5
AC Input Connector and Voltage Selection .....	2-6
AC Input Cord .....	2-6
AC Input Wire Connection .....	2-7
Functional Tests .....	2-9
Equipment Required .....	2-9
Power-on Check .....	2-9
Voltage Mode Operation Check .....	2-10
Current Mode Operation Check .....	2-10
Front Panel Function Checks .....	2-11

## Contents

---

Load Connection	2-12
Load Wiring	2-12
Insulation Rating	2-12
Current Carrying Capacity	2-12
Load Wiring Length for Operation with Sense Lines	2-13
Noise and Impedance Effects	2-14
Making Load Connections	2-14
Output Cover	2-14
7.5 V to 100 V Models	2-16
150 V to 600 V Models	2-17
Inductive Loads	2-18
Connecting Single Loads	2-18
Connecting Multiple Loads	2-19
Local and Remote Sensing	2-21
Sense Wiring	2-21
Local Sensing	2-21
Using Remote Sensing	2-23

### 3 Local Operation

Introduction	3-2
Standard Operation	3-3
Operating Modes and Automatic Crossover	3-3
Constant Voltage Mode Operation	3-4
Constant Current Mode Operation	3-4
Automatic Mode Crossover	3-4
Shipped Configuration (Local Control Mode)	3-5
Setting Output Voltage and Current Limit	3-6
Using Over Voltage Protection (OVP)	3-7
Front Panel OVP Operation	3-7
Resetting the OVP Circuit	3-8
Using the Shutdown Function	3-9
STANDBY Switch	3-9
Controlling the Shutdown Function via the J2 Connector	3-9
Using Multiple Supplies	3-11
Configuring Multiple Supplies for Series Operation	3-12
Configuring Multiple Supplies for Parallel Operation	3-13
Sensing for Parallel Operation	3-14

---

Configuring Multiple Supplies for Split Supply Operation	3-15
Two Positive Voltages	3-15
Positive-negative Supply	3-16
Over Temperature Protection (OTP)	3-17

## 4 Remote Operation

Introduction	4-2
Isolated Programming	4-2
Remote Digital Programming	4-2
Remote Analog Programming of Output Voltage and Current Limit	4-3
Remote Programming Options	4-3
Remote Analog Programming Procedure	4-3
Remote Monitoring of Output Voltage and Current	4-7
Readback Signals	4-7

## 5 Calibration and Troubleshooting

Calibration Setup	5-2
Service Environment and Precautions	5-2
Equipment Required	5-2
Accessing Calibration Potentiometers	5-3
Removing Option Card	5-3
Calibrating for Programming Accuracy	5-5
Voltage Programming Circuit Calibration	5-5
Current Limit Programming Circuit Calibration	5-6
Calibrating for Readback Accuracy	5-7
Output Voltage Monitor Circuit Calibration	5-7
Output Current Monitor Circuit Calibration	5-8
User Diagnostics	5-9
Emergency Shutdown	5-9
Unusual or Erratic Operation	5-9
Troubleshooting for Operators	5-10

**A Specifications**

Electrical Specifications ----- A-2  
Additional Specifications ----- A-6  
Input Conditions ----- A-7  
Additional Features ----- A-8  
Remote Programming and Monitoring ----- A-8  
Environmental Specifications ----- A-9  
Mechanical Specifications-----A-10

**Warranty and Return Information ----- WA-1**

Warranty ----- WA-1  
Return Material Authorization Policy ----- WA-3  
Return Procedure----- WA-4  
Out of Warranty Service ----- WA-4  
Information About Your System ----- WA-4

# Figures

Figure 1-1	Power Supply Front Panel- - - - -	1-4
Figure 1-2	Power Supply Rear Panel (Low voltage (7.5 V to 100 V) model shown.) -	1-5
Figure 1-3	Programming and Monitoring SW1 Switch - - - - -	1-6
Figure 1-4	Programming and Monitoring J2 Connector- - - - -	1-7
Figure 2-1	Shipping or Storage Carton Label- - - - -	2-4
Figure 2-2	AC Input Cover and Strain Relief- - - - -	2-8
Figure 2-3	Maximum Load Wire Length for 1 V Line Drop- - - - -	2-13
Figure 2-4	Output Strain Relief and Cover - - - - -	2-15
Figure 2-5	Typical Load Connection Hardware - - - - -	2-16
Figure 2-6	Output Voltage Connector- - - - -	2-17
Figure 2-7	Single Load with Local Sensing (Default) - - - - -	2-18
Figure 2-8	Single Load with Remote Sensing - - - - -	2-19
Figure 2-9	Multiple Loads with Local Sensing - - - - -	2-20
Figure 2-10	Multiple Loads with Remote Sensing - - - - -	2-20
Figure 2-11	J10 Sense Connector - - - - -	2-22
Figure 2-12	Connecting Remote Sense Lines - - - - -	2-24
Figure 3-1	Operating Modes- - - - -	3-3
Figure 3-2	Series Operation of Multiple Supplies- - - - -	3-12
Figure 3-3	Parallel Operation of Multiple Supplies- - - - -	3-14
Figure 3-4	Split Supply Operation of Multiple Supplies - - - - -	3-15
Figure 3-5	Split Supply Operation of Multiple Supplies - - - - -	3-16
Figure 4-1	Connecting Programming Sources to J2 Connector- - - - -	4-6
Figure 5-1	Programming and Monitoring Calibration Locations - - - - -	5-4
Figure A-1	Typical Input Current Characteristics - - - - -	A-7
Figure A-2	Dimensional Drawings - - - - -	A-12



# Tables

Table 1-1	Available Voltage and Current Ranges - - - - -	1-2
Table 1-2	Rear Panel SW1 Switch Assignments - - - - -	1-6
Table 1-3	Rear Panel J2 Connector Terminals and Functions - - - - -	1-8
Table 2-1	Basic Setup Procedure - - - - -	2-2
Table 2-2	Operation AC Input Voltage Range and Frequency - - - - -	2-6
Table 2-3	AC Wire Specification - - - - -	2-6
Table 2-4	Current Carrying Capacity for Load Wiring - - - - -	2-13
Table 2-5	Rear Panel J10 Sense Connector Terminals and Functions - - - - -	2-22
Table 3-1	Shipped Configuration (Local Control Mode) - - - - -	3-5
Table 3-2	Switch Settings for Shutdown Circuit Logic - - - - -	3-10
Table 3-3	Switch Settings for Over Temperature Recovery Options - - - - -	3-17
Table 4-1	Remote Programming Options - - - - -	4-3
Table 4-2	Power Supply Settings for Different Programming Sources - - - - -	4-5
Table 4-3	Settings for Remote Monitoring of Readback Signals - - - - -	4-7
Table 5-1	User Diagnostics - - - - -	5-10
Table A-1	Specifications for 7.5 V to 40 V Models - - - - -	A-2
Table A-2	Specifications for 60 V to 600 V Models - - - - -	A-4





# 1

# Features and Specifications

Chapter 1 describes the XFR 2800 Watt Series Programmable DC Power Supply and lists the features.

## Description

This series of power supplies provides low noise, precisely regulated, variable DC output at 2800 watts of output power. Over voltage protection (OVP) and thermal shutdown are standard. Front panel controls and indicators are extensive. Select from several remote control choices: standard analog programming, optional isolated programming or readback, and optional GPIB programming or RS-232 control. Remote monitoring of output voltage and current is a standard feature. Use this power supply either on your bench or in a standard 19 in. (483 mm) rack: the unit occupies only 3.5 in. (2 U) of vertical rack space. Designed for continuous use in standalone or systems applications, this power supply is typically used to power DC equipment, control magnets, or burn in components. See Table 1-1 for the list of available models.

**Table 1-1** Available Voltage and Current Ranges

Model	Voltage Range	Current Range
7.5-300	0-7.5 V	0-300 A
12-220	0-12 V	0-220 A
20-130	0-20 V	0-130 A
33-85	0-33 V	0-85 A
40-70	0-40 V	0-70 A
60-46	0-60 V	0-46 A
100-28	0-100 V	0-28 A
150-18	0-150 V	0-18 A
300-9	0-300 V	0-9 A
600-4	0-600 V	0-4 A

## Features and Options

- Simultaneous digital display of both voltage and current.
- Ten-turn front panel voltage and current controls for high resolution setting of the output voltage and current from zero to the rated output.
- Automatic mode crossover into current or voltage mode.
- Front panel push-button control of output standby mode and preview of voltage, current, or over voltage protection setpoints. Front panel light emitting diode (LED) indicators for voltage and current mode operation, OVP, remote programming mode, and shutdown. Front panel control of OVP.
- Multiple units can be connected in parallel or in series to provide increased current or voltage.
- Over temperature protection (OTP) shutdown; latches or automatically resets.
- Remote analog voltage and current limit programming with selectable programming ranges.
- External monitor signals for output voltage and current.
- Isolated analog remote programming control of the output voltage or current and isolated readback of output voltage and current with the optional ISOL Interface.
- Optional internal GPIB or RS-232 control for remote digital programming and readback from a computer.
- Rack mount brackets at the front panel are standard.

## Front Panel Controls

See Figure 1-1 to review the controls, LEDs, and meters located on the power supply's front panel. Check the following sections for additional descriptions of front panel controls and functions.

- “Mechanical Specifications” on page A–10
- “Functional Tests” on page 2–9
- Chapter 3, “Local Operation”

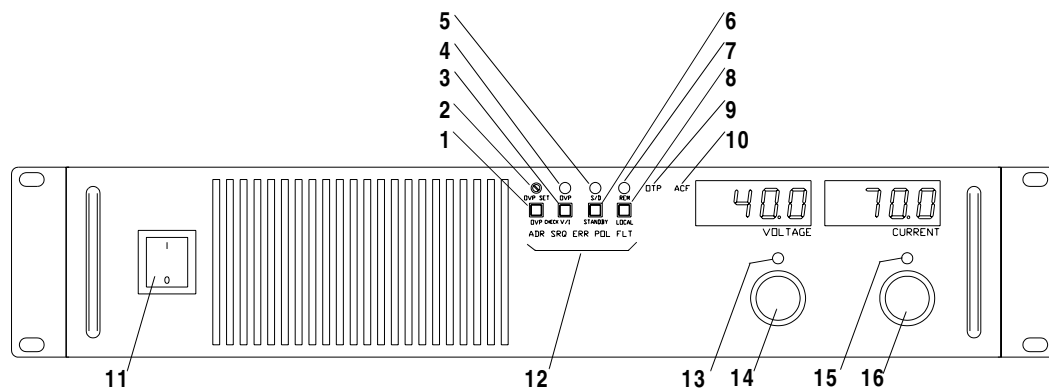
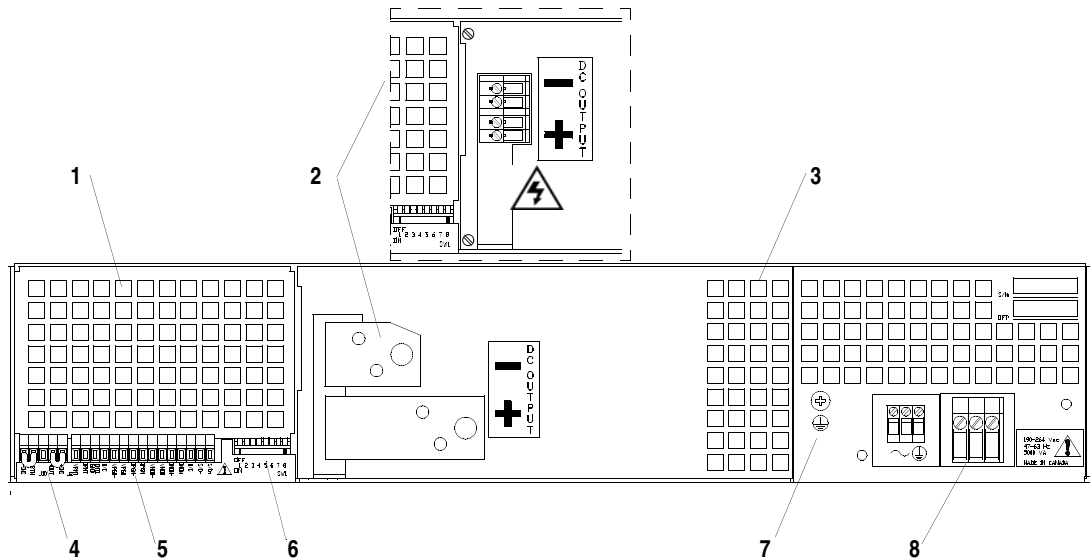

**Figure 1-1** Power Supply Front Panel

No.	Description
1	OVP Check: OVP Setting Preview Switch (See page 3–7 for more information.)
2	OVP Set: OVP Adjust Potentiometer (See page 3–7 for more information.)
3	V/I Check: Local Voltage & Current Limit Setting Preview Switch (See page 2–9 for more information.)
4	OVP Shutdown LED
5	S/D: Shutdown LED
6	Standby Switch (See page 3–9 for more information.)
7	Rem: Remote Programming LED
8	Local: Return to Local Programming, for units with digital programming interface installed
9	OTP: Over Temperature Shutdown LED
10	ACF: AC Fail LED
11	AC Power Switch
12	Remote Programming LEDs: For units with digital programming interface installed
13	Voltage Mode LED
14	Output Voltage Control Knob
15	Current Mode LED
16	Output Current Control Knob

## Rear Panel Connectors and Switch

Use the rear panel SW1 Programming, Monitoring, and Shutdown Select switch and the rear panel J2 Programming and Monitoring connector to choose among several remote programming and monitoring options. See Figure 1-2 for switches and connectors available at the rear panel. See “Rear Panel SW1 Switch” on page 1–6 and “Rear Panel J2 Connector” on page 1–7 for a list of switches and connector functions, and procedures for using them.



**Figure 1-2** Power Supply Rear Panel (Low voltage (7.5 V to 100 V) model shown.)

No.	Description
1	Blank Subplate: Replaced if digital programming interface installed.
2	DC Output Connector: For high voltage (150 V to 600 V) models. See inset and page 2–12.
3	Fan Exhaust Vents: Do not block.
4	J10 Sense Connector. See page 2–21 for more information.
5	J2 Programming and Monitoring Connector. See page 1–7 for more information.
6	SW1 Switch. See page 1–6 for more information.
7	Chassis Ground Screw: 3/8 in. (9 mm) maximum penetration into unit.
8	AC Input Connector: See page 2–5 for more information.

## Rear Panel SW1 Switch

The SW1 Programming, Monitoring, and Shutdown Select switch is an 8-position piano DIP switch located on the power supply's rear panel. See Figure 1-3. The SW1 switch enables you to choose:

- Resistive programming of output voltage or current limit
- Output voltage and current limit programming scales
- Output voltage and current monitor scales
- Remote shutdown circuit logic
- Over temperature shutdown mode

- 1 Resistive Programming of Output Voltage
- 2 Resistive Programming of Output Current
- 3 Selects Output Voltage Programming Source Range
- 4 Selects Output Current Limit Programming Source Range
- 5 Selects Output Voltage Monitor Range
- 6 Selects Output Current Monitor Range
- 7 Selects Remote Shutdown Logic
- 8 Selects Over Temperature Shutdown Reset Mode

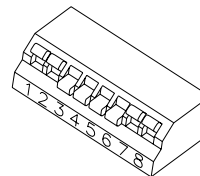

**Figure 1-3** Programming and Monitoring SW1 Switch  
(Switch is shown in factory default configuration.)

Table 1-2 shows the functions assigned to each SW1 switch.

**Table 1-2** Rear Panel SW1 Switch Assignments

Switch	Function	Open <sup>a</sup>	Closed
SW1-1	1 mA current source for resistive programming of output voltage	<u>Voltage source programming</u>	Resistive programming (0-5 k, 0-10 k)
SW1-2	1 mA current source for resistive programming of output current limit	<u>Voltage source programming</u>	Resistive programming (0-5 k, 0-10 k)
SW1-3	Output voltage programming source range select	0-5 V (0-5 k)	<u>0-10 V</u> (0-10 k)
SW1-4	Output current limit programming source range select	0-5 V (0-5 k)	<u>0-10 V</u> (0-10 k)
SW1-5	Output voltage monitor range select	0-5 V	<u>0-10 V</u>
SW1-6	Output current monitor range select	0-5 V	<u>0-10 V</u>
SW1-7	Remote shutdown logic select	<u>HIGH=OFF</u>	HIGH=ON
SW1-8	Over temperature shutdown reset mode select	<u>Auto reset</u>	Latch OFF

a. Factory defaults underlined.

## Resetting the Switches

Before making any changes to the switch settings, disable the power supply output by pushing the front panel STANDBY switch to its IN position. This temporarily shuts down the power supply. The front panel S/D LED turns on. Then, use any small, flat-bladed screwdriver to change the switch settings.

Any of the eight switches on SW1 is OFF when it has been flipped up to break contact, ON when flipped down to close contact.

## Rear Panel J2 Connector

The J2 Programming and Monitoring connector is a 15-terminal wire clamp connector located on the power supply's rear panel. See Figure 1-4. The J2 connector provides access to the following functions:

- Remote programming of output voltage AND/OR current limit
- Remote monitoring of calibrated readback signals for output voltage and output current
- Remote control of the shutdown function using a 2.5 V to 15 V signal

**Figure 1-4** Programming and Monitoring J2 Connector

- |    |  |
|----|--|
| 1  | Remote Output Voltage Programming Select       |
| 2  | Remote Output Current Limit Programming Select |
| 3  | Control Ground                                 |
| 4  | No connection                                  |
| 5  | Voltage Program Signal Return                  |
| 6  | Output Voltage Programming Input               |
| 7  | Current Program Signal Return                  |
| 8  | Output Current Limit Programming Input         |
| 9  | Voltage Monitor Signal Return                  |
| 10 | Output Voltage Monitor                         |
| 11 | Current Monitor Signal Return                  |
| 12 | Output Current Monitor                         |
| 13 | No connection                                  |
| 14 | Shutdown (S/D) Signal Return (-)               |
| 15 | S/D Input (+)                                  |

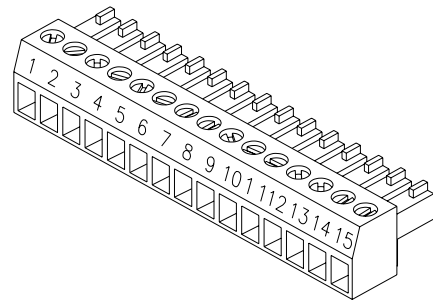

See Table 1-3 for the list of the J2 connector terminal numbers, their references, and corresponding functions.

**Table 1-3** Rear Panel J2 Connector Terminals and Functions

Connector	Reference	Name	Function
J2-1	VRMT	Remote Output Voltage Programming Select	Selects remote output voltage programming when jumpered to pin 3.
J2-2	IRMT	Remote Output Current Limit Programming Select	Selects remote output current limit programming when jumpered to pin 3.
J2-3	CNTL GND	Control Ground	Control ground.
J2-4	N/C	No connection	None.
J2-5	VPGM–	Voltage Program Signal Return	Return for voltage program signal.
J2-6	VPGM	Output Voltage Programming Input	Input for voltage programming signals from an analog device.
J2-7	IPGM–	Current Program Signal Return	Return for current program signal.
J2-8	IPGM	Output Current Limit Programming Input	Input for current limit programming signals from an analog device.
J2-9	VMON–	Voltage Monitor Signal Return	Return for voltage monitor signal.
J2-10	VMON	Output Voltage Monitor	Output for output voltage monitor signal.
J2-11	IMON–	Current Monitor Signal Return	Return for current monitor signal.
J2-12	IMON	Output Current Monitor	Output for output current monitor signal.
J2-13	N/C	No connection	None.
J2-14	S/D–	Shutdown Signal Return (–)	Return for shutdown signal.
J2-15	S/D	S/D Input (+)	Input for shutdown signal.



---

## Making J2 Connections



### CAUTION

Do not attempt to bias program/monitor signal return (J2 terminals 5, 7, 9, and 11) relative to the supply output because control ground (J2-3) and the program/monitor signal returns are at the same potential as the power supply return in a standard unit. Use the Isolated Programming (ISOL) Interface option to allow control from a programming source at a different potential relative to the supply's output.



### CAUTION

To maintain the isolation of the power supply output and prevent ground loops, use an isolated (ungrounded) programming source when operating the power supply via remote analog control at the J2 connector.

Make connections to the J2 connector using its screw-type wire clamps. Before making any connections, turn the power supply OFF and wait until the front panel displays have gone out. You can unplug the connector from the back of the unit in order to make it easier to install the required wiring.

## Wiring



### WARNING: Shock hazard

There is a potential shock hazard when using a power supply with a rated output greater than 40 V. Use wiring with a minimum insulation rating equivalent to the maximum output voltage of the power supply. For example, select TEW-105, 105 °C, 600 V wiring for use with a 600 V, 4 A model power supply.

For most connectors and jumpers, use any suitable wire such as 16 to 24 AWG stranded wire. For lowest noise performance, use shielded pair wiring. Strip wires 0.26 in. (6.5 mm), insert, and tighten the wire clamp.



# 2

## Installation

Chapter 2 provides recommendations and procedures for inspecting, installing, and testing the power supply.

## Basic Setup Procedure

See Table 2-1 for a summary of the basic setup procedure and an overall view of the subsections in Chapter 2. Use the procedure as a quick reference if you are familiar with the installation requirements for the power supply. If you want more information, each step in the procedure refers to subsequent sections which contain more details. Execute each step in the sequence given.

**Table 2-1** Basic Setup Procedure

Step #	Description	Action	Reference
1	Inspection	Perform an initial physical inspection of the supply.	“Inspection, Cleaning, and Packaging” on page 2–3
2	Installation	Install the supply (bench or rack mount), ensuring adequate ventilation.	“Location, Mounting, and Ventilation” on page 2–4
3	Input Power	Connect AC input power.	“AC Input Power” on page 2–5
4	Test	Perform functional tests for voltage mode operation, current mode operation, and front panel controls.	“Functional Tests” on page 2–9
5	Load	Connect the load.	“Load Connection” on page 2–12
6	Sensing	Connect sensing lines.	“Local and Remote Sensing” on page 2–21

See Chapter 3 for instructions about front panel operation, OVP, OTP, shutdown, and using multiple supplies. You will find remote programming and monitoring described in Chapter 4.

# Inspection, Cleaning, and Packaging

## Initial Inspection

When you first receive your unit:

1. Inspect the unit for scratches and cracks, and for broken switches, connectors, and displays.
2. Ensure that the packing box contains the AC input cover and strain relief kit (see Figure 2-2).
3. Have the service technician check the printed circuit board and its components if you suspect internal damage.

If the unit is damaged, save all packing materials and notify the carrier immediately. See packing instructions on page 2–3.

## Periodic Cleaning

No routine servicing of the power supply is required except for periodic cleaning. Whenever a unit is removed from operation, clean metal surfaces with naphtha or an equivalent solvent and the front panel with a weak solution of soap and water. Use low-pressure compressed air to blow dust from in and around components on the printed circuit boards.

## Packaging for Shipping or Storage

Follow these instructions to prepare the unit for shipping or storage.

1. When returning the unit or sending it to the service center, attach a tag to the unit stating its model number, available from the front panel label, and its serial number, available from the rear panel label. Give the date of purchase and an invoice number, if you have it, as well as a brief description of the problem.
2. For storage or shipping, repack the power supply in its original container. If the original container is not available, seal the unit in a plastic bag and then pack it in a 200 lb. (90 kg) test, corrugated cardboard carton large enough to allow 2 in. (5 cm) of cushioning material to surround the unit. Use a material such as foam slabs or chips.
3. Label the carton as shown in Figure 2-1.
4. If shipping, mark the address of the service center and your return address on the carton.

5. If storing, stack no more than eight cartons high. Check the storage temperature range and storage altitude specification in “Environmental Specifications” on page A-9.

## POWER SUPPLY

Model Number:

Serial Number:

## FRAGILE — ELECTRONIC EQUIPMENT

Figure 2-1 Shipping or Storage Carton Label

## Location, Mounting, and Ventilation

Use the power supply in rack-mounted or benchtop applications.

### Rack Mounting



#### **WARNING: Shock hazard**

Ensure that any mounting screws do not penetrate more than 1/8 in. (3.0 mm) into the sides of the unit.

---

The power supply is designed to fit in a standard 19 in. (483 mm) equipment rack. To install:

1. Use the rack mount brackets at either side of the front panel to install the power supply in a rack.
2. Provide adequate support for the rear of the unit without obstructing the ventilation inlets on the sides of the unit. Use a support bar at the rear of the unit. Follow the manufacturer's instructions to install the support bar.

To install the power supply with rack mount slides, use a commercially-available slide kit. Follow the manufacturer's instructions to install the slides. Add a 1/8 in. (3.0 mm) spacer between the chassis and the slides.

## Ventilation

Whether you place the power supply in a rack or on a bench, allow cooling air to reach the ventilation inlets on the front and sides of the unit and allow 4 in. (10 cm) of unrestricted air space at the rear of the unit for the fan exhaust. Any ventilation space at the top and bottom of the supply will further lower internal operating temperatures.

Check page A-9 for the operating ambient temperature range and the operating altitude specification.

## AC Input Power

---



### **WARNING: Shock hazard**

There is a potential shock hazard if the power supply chassis and cover are not connected to an electrical ground via the safety ground in the AC input connector. Ensure that the power supply is connected to a grounded AC outlet with the recommended AC input connector configured for the available line voltage as described in this section.

---



### **WARNING: Shock hazard**

Disconnect AC power from the unit before removing the cover. Even with the front panel power switch in the OFF position, live line voltages are exposed when the cover is removed. Repairs must be made by experienced service technicians only.

---



### **CAUTION**

When power switch is turned on, output voltage or current previously set will be applied to loads.

---

## AC Input Connector and Voltage Selection

The AC input connector is a 3-terminal wire clamp located on the power supply's rear panel. See Figure 2-2 on page 2–8. See Table 2-2 for the input voltage ranges and frequency required to operate the power supply.

**Table 2-2** Operation AC Input Voltage Range and Frequency

AC Voltage Range	Frequency
190-264 Vac 1 $\phi$ (24.3 A maximum at 208 Vac; 22.4 A maximum at 230 Vac)	47-63 Hz

**AC Fail LED** The AC Fail (ACF) LED turns on when the input voltage is outside of the range specified for the power supply. The LED turns off when the input voltage is within the range.

## AC Input Cord



### WARNING

The AC input cord is the disconnect device for the power supply. The plug must be readily identifiable by and accessible to the operator. The input cord must be no longer than 9.84 feet (3 m).

The AC input cord we recommend is specified in Table 2-3. Add a non-locking plug suitable for use in the country in which you are operating. If you require a special cord, call us.

**Table 2-3** AC Wire Specification

Wire Size	Ratings	Cable Outside Diameter
3 x 12 AWG stranded copper	60 °C minimum, 300 V	0.545-0.708 in. (13.63-17.7 mm)



---

## AC Input Wire Connection

---

**WARNING: Shock hazard**

Ensure that the chassis ground screw does not penetrate more than 3/8 in. (9 mm) into the rear panel of the unit.

---

1. Strip the outside insulation on the AC cable approximately 4 in. (10 cm). Trim the wires so that the ground wire is 0.5 in. (12 mm) longer than the other wires. Strip 0.55 in. (14 mm) at the end of each of the wires. See Figure 2-2 on page 2–8 detail (top).
2. Unscrew the base of the strain relief from the helix-shaped body. Insert the base through the outside opening in the AC input cover and, from the inside, screw the locknut securely onto the base.
3. Slide the helix-shaped body onto the AC cable. Insert the stripped wires through the strain relief base until the outer cable jacket is flush with the edge of the base. Tighten the body to the base while holding the cable in place. The cable is now securely fastened inside the strain relief.
4. Route the AC wires to the input connector terminals as required. For input connector terminal locations, see lower inset in Figure 2-2. To connect the wiring, loosen the terminal screw, insert the stripped wire into the terminal, and tighten the screw securely.
5. Route the wires inside the cover to prevent pinching. Fasten the AC input cover to the unit using the (6-32 x 1 1/4 in. (2)) screws, flat washers, and lock washers provided. See Figure 2-2.

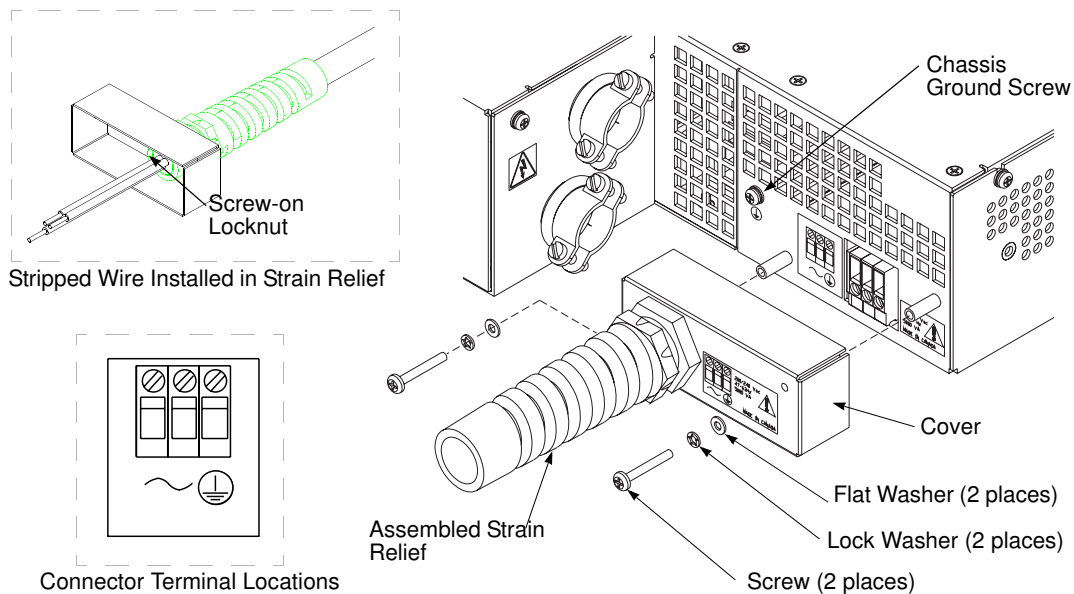

Figure 2-2 AC Input Cover and Strain Relief

## Functional Tests

These functional test procedures include power-on and front panel function checks as well as voltage and current mode operation checks. Refer to front and rear panel diagrams in “Front Panel Controls” on page 1–3 and “Rear Panel Connectors and Switch” on page 1–5.

### Equipment Required

- Digital voltmeter (DVM) rated better than 0.5% accuracy.
- DC shunt 1 mV/A ( $\pm 0.25\%$ ) with connecting wire. The recommended current ratings for the DC shunt and the wire must be at least 10% more than the output current of the power supply.

### Power-on Check

1. Ensure that the AC power switch is in the OFF position.
  2. Ensure that the output sense lines are connected in the default configuration. (The local sense lines are connected between terminals 1 and 2 and between terminals 4 and 5 on the J10 sense connector as shown on the rear panel diagram in Figure 1-2 on page 1–5.)
  3. Turn the voltage and current controls fully counter-clockwise.
  4. Connect the unit to an AC outlet.
  5. Turn the front panel AC power switch to ON.
- After a short, power-on delay, the front panel digital meters light up and the green voltage mode LED turns on. Both voltmeter and ammeter displays read zero.

## Voltage Mode Operation Check

1. Ensure the voltage and current controls on the front panel are turned fully counter-clockwise.
2. Connect that the output sense lines are connected in the default configuration. (The local sense lines are connected between terminals 1 and 2 and between terminals 4 and 5 on the J10 sense connector as shown on the rear panel diagram in Figure 1-2 on page 1-5.)
3. Turn the voltage and current controls fully counter-clockwise.
4. Compare the DVM reading with the front panel voltmeter reading to verify the accuracy of the internal voltmeter. Both readings should be the same. The minimum control range is from zero to the maximum rated output for the power supply model. The voltage mode LED turns on.
5. Turn the front panel AC power switch to OFF.

## Current Mode Operation Check

1. Ensure the front panel AC power switch is set to OFF.
2. Turn the voltage and current controls on the front panel fully counter-clockwise.
3. Connect the DC shunt across the output terminals on the rear panel.
4. Connect the DVM across the DC shunt.
5. Turn the AC power switch to ON.
6. Turn the voltage control 1 or 2 turns clockwise.
7. Turn the current control slowly clockwise.
8. Compare the DVM reading with the front panel ammeter reading using  $I=V/R$  where  $I$  is the current,  $V$  is the DVM reading, and  $R$  is the DC shunt resistance. The minimum control range is from zero to the maximum rated output for the power supply model. The current mode LED turns on.
9. Turn the AC power switch to OFF.
10. Disconnect the DVM and the shunt.

## Front Panel Function Checks

1. Turn the front panel AC switch to ON.
2. Set voltage and current controls fully clockwise. Push the STANDBY switch to its IN position and check that the voltmeter reading falls to zero and the red S/D (Shutdown) LED turns on. Push the STANDBY switch once again to reset it to its OUT position. The S/D LED turns off and the voltmeter reading returns to its previous value.
3. Press the STANDBY switch to its IN position.
4. Press the OVP CHECK switch and check that the voltmeter displays approximately the model-rated output voltage plus 10%.
5. Turn the OVP SET potentiometer counter-clockwise and check that the voltmeter reading decreases. Continued turning (up to 20 turns) will see the reading decrease to approximately 5% of the model-rated voltage output. Turn the OVP SET potentiometer clockwise until the voltmeter once again displays approximately the model-rated output voltage plus 10%.
6. Press the STANDBY switch to its OUT position.
7. Press the V/I CHECK switch and check that the voltmeter and ammeter display the power supply output ratings.
8. Turn the front panel AC power switch to OFF.

Note: You can use the front panel LOCAL button only when a digital programming interface has been installed in your power supply

## Load Connection

This section provides recommendations for load wires and how to connect them for both single and multiple load configurations.

### Load Wiring



#### **WARNING**

Ensure that the chassis ground screw does not penetrate more than 3/8 in. (9 mm) into the rear panel of the unit.

---

When connecting load wiring to the power supply, consider the following factors:

- insulation rating of the wire
- current carrying capacity of the wire
- maximum load wiring length for operation with sense lines
- noise and impedance effects of the load lines

### Insulation Rating

Use load wiring with a minimum insulation rating equivalent to the maximum output voltage of the power supply. For example, select TEW-105, 105 °C, 600 V wiring for use with a 600 V, 4 A model power supply

### Current Carrying Capacity

As a minimum, load wiring must have a current capacity greater than the output current rating of the power supply. This ensures that the wiring will not be damaged even if the load is shorted. Table 2-4 shows the maximum current rating, based on 450 A/cm<sup>2</sup>, for various gauges of wire rated for 105 °C operation. Operating at the maximum current rating results in an approximately 30 °C temperature rise for a wire operating in free air. Where load wiring must operate in areas with elevated ambient temperatures or bundled with other wiring, use larger gauges or wiring rated for higher temperatures.

**Table 2-4** Current Carrying Capacity for Load Wiring

Wire Size (AWG)	Maximum Current (A)	Wire Size (AWG)	Maximum Current (A)
20	2.5	6	61
18	4	4	97
16	6	2	155
14	10	1	192
12	16	1/0	247
10	21	2/0	303
8	36		

### Load Wiring Length for Operation with Sense Lines

For applications using remote sensing, you must limit the voltage drop across each load wire. Figure 2-3 shows some allowable wire lengths for a given load current and wire size. We recommend that you use the larger load wiring to ensure a smaller voltage drop (1 V typical maximum), although units will compensate for up to 5 V drop in each line. See also “Local and Remote Sensing” on page 2–21.

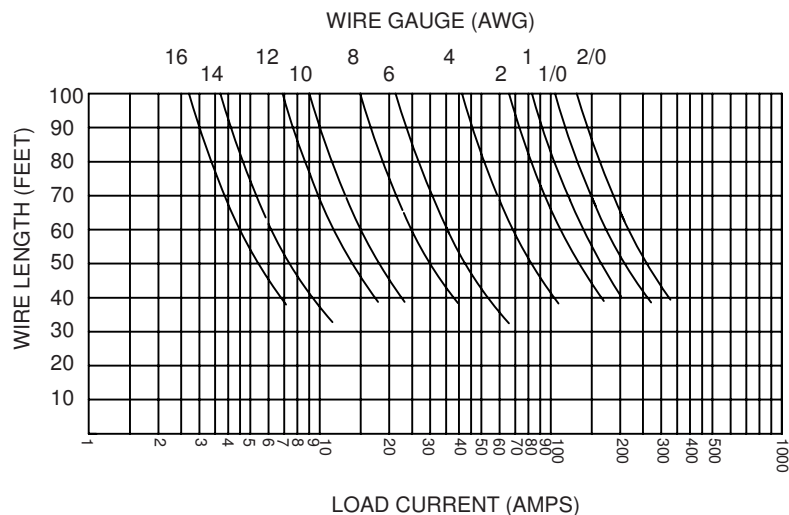
**Figure 2-3** Maximum Load Wire Length for 1 V Line Drop

## Noise and Impedance Effects

To minimize noise pickup or radiation, use shielded pair wiring of the shortest possible length for load wires. Connect the shield to the chassis via a rear panel mounting screw. Where shielding is impossible or impractical, simply twisting the wires together will offer some noise immunity. When using local sense connections, use the largest practical wire size to minimize the effects of load line impedance on the regulation of the supply.

## Making Load Connections

---



### CAUTION

When making connections to the bus bars, ensure that each terminal's mounting hardware and wiring assembly are placed to avoid touching the other terminal and shorting the power supply output. Heavy connecting cables must have some form of strain relief to avoid loosening the connections or bending the bus bars.

---

Make load connections at the rear of the power supply at the positive and negative output bus bars or to the 4-terminal wire clamp connector, depending on the model.

## Output Cover

The power supply comes with a bus bar cover and strain relief. See Figure 2-4. This cover is also installed on models fitted with the high voltage output connector.

To detach the 2-part cover:

1. Undo 6-32 x 5/16 in. Phillips pan head screws, 6 x 0.288 in. lock washers, and 6 x 5/16 in. flat washers (3 places) from the top cover.
2. Pull up on the top cover to remove it.
3. Undo 6-32 x 1/4 in. Keps nuts and 6 x 5/16 in. flat washers from the chassis-mounted PEM studs (3 places) to remove the chassis cover.



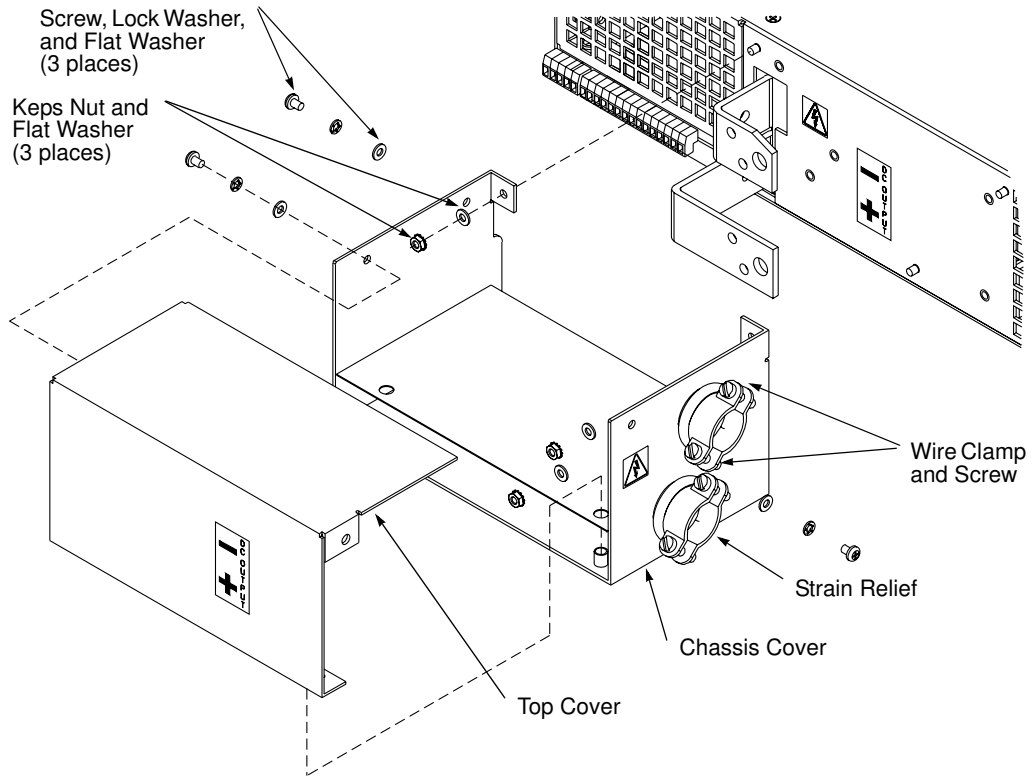

**Figure 2-4** Output Strain Relief and Cover

## 7.5 V to 100 V Models

The 7.5 V to 100 V models are equipped with output bus bars. To make a typical load connection to a 7.5 V, 300 A power supply:

1. Strip the ends of the wires.
2. Remove the top part of the output cover. Do not remove the chassis-mounted part of the cover.
3. Loosen wire clamp screws (part of strain relief). Do not disassemble the strain relief.
4. Insert load wire in strain relief.
5. Install connectors to load wiring.
6. Fasten connectors to bus bars with 5/16 in. x 5/8 in. (M8 x 16 mm) screws, 5/16 in. (M8) flat washers, lock washers, and hex nuts as shown in Figure 2-5.
7. Tighten the strain relief clamp.
8. Replace the top cover.

Note: Bus bar hole sizes are one of 0.343 in. (8.7 mm) D; two of 0.197 in. (5.0 mm) D.

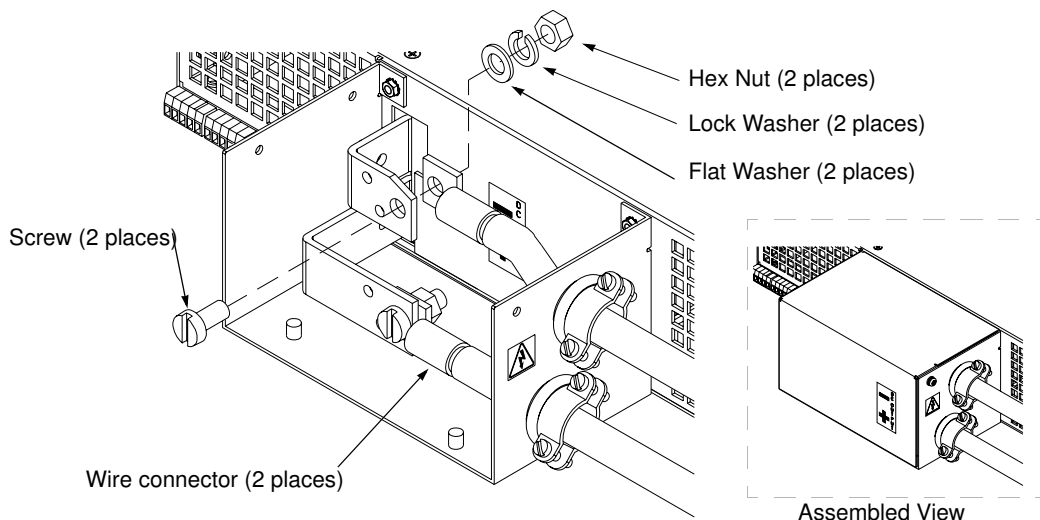

**Figure 2-5** Typical Load Connection Hardware  
(For 7.5 V to 100 V models)

---

**150 V to 600 V Models****WARNING: Shock hazard**

To protect personnel against accidental contact with hazardous voltages, ensure that the load, including connections, has no live parts which are accessible. Also ensure that the insulation rating of the load wiring and circuitry is greater than or equal to the maximum output voltage of the power supply.

---

The 150 V to 600 V models have a 4-terminal, wire clamp output connector. See Figure 2-6 for a labelled drawing of the wire clamp connector. To prepare and connect the load wiring:

1. Strip 0.4 in. (10 mm) at the ends of the wires.
2. Remove the top part of the output cover. Do not remove the chassis-mounted part of the cover.
3. Loosen wire clamp screws (part of strain relief). Do not disassemble the strain relief.
4. Insert load wire in strain relief.
5. To connect the wiring, loosen each terminal screw, insert a stripped wire into the terminal, and tighten the screw securely.
6. Tighten the strain relief clamp.
7. Replace the top cover.

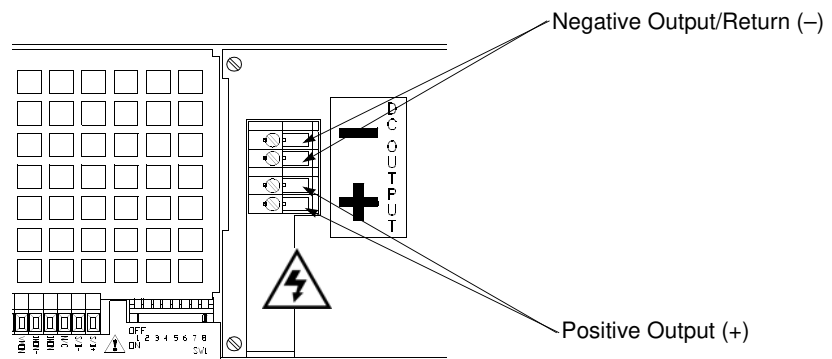

**Figure 2-6** Output Voltage Connector  
(For 150 V to 600 V models.)

## Inductive Loads

To prevent damage to the power supply from inductive kickback, connect a diode across the output. The diode must be rated at greater than or equal to the supply's output voltage and have a current surge rating greater than or equal to the supply's output rating. Connect the cathode to the positive output and the anode to the negative output/return.

Where positive load transients such as back EMF from a motor may occur, connect a transorb or a varistor across the output to protect the power supply. The breakdown voltage rating for the transorb or varistor must be approximately 10% higher than the rated supply output.

## Connecting Single Loads

Figure 2-7 and Figure 2-8 show recommended load and sensing connections for single loads. Local sense lines shown are default connections at the rear panel J10 sense connector as identified on Figure 1-2 on page 1-5.

You do not need remote sensing for basic operation of your supply. However, if you wish to correct any small drops in your load lines, then use the remote sensing feature. See "Local and Remote Sensing" on page 2-21 for more information.

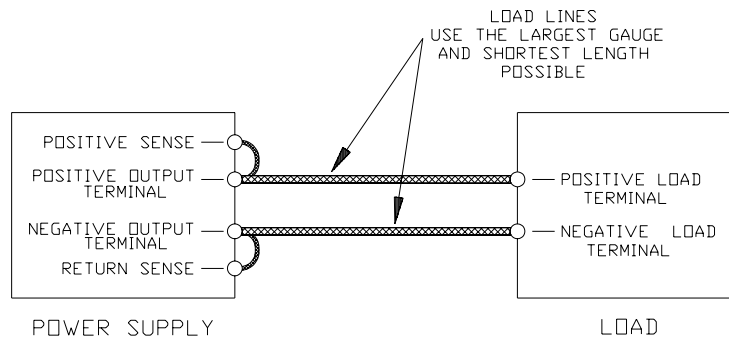

**Figure 2-7** Single Load with Local Sensing (Default)

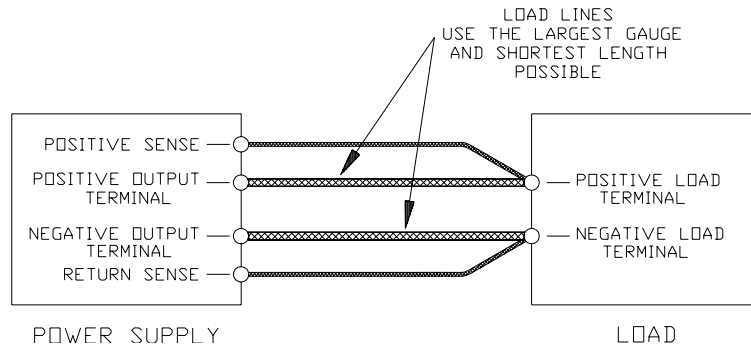

**Figure 2-8** Single Load with Remote Sensing

## Connecting Multiple Loads

Proper connection of distributed loads is an important aspect of power supply use. Two common methods of connection are the parallel power distribution method and the radial power distribution method.

**Parallel Power Distribution** This distribution method involves connecting leads from the power supply to one load, from that load to the next load, and so on for each load in the system. This method results in the voltage at each load depending on the current drawn by the other loads and allows DC ground loops to develop. Except for low current applications, we do not recommend using this method.

**Radial Power Distribution Method** To connect distributed loads, we recommend that you use radial power distribution. With this method, you connect power to each load individually from a single pair of terminals designated as the positive and negative distribution terminals. These terminals may be the power supply output terminals, the terminals of one of the loads, or a distinct set of terminals especially established for distribution use. Connect the sense leads to these terminals to compensate for losses and to minimize the effect of one load upon another.

Figure 2-9 and Figure 2-10 show recommended load and sensing connections for multiple loads. Local sense lines shown are default J10 sense connections. See “Local and Remote Sensing” on page 2–21 for more information about using remote sensing and grounding the sense line shield.

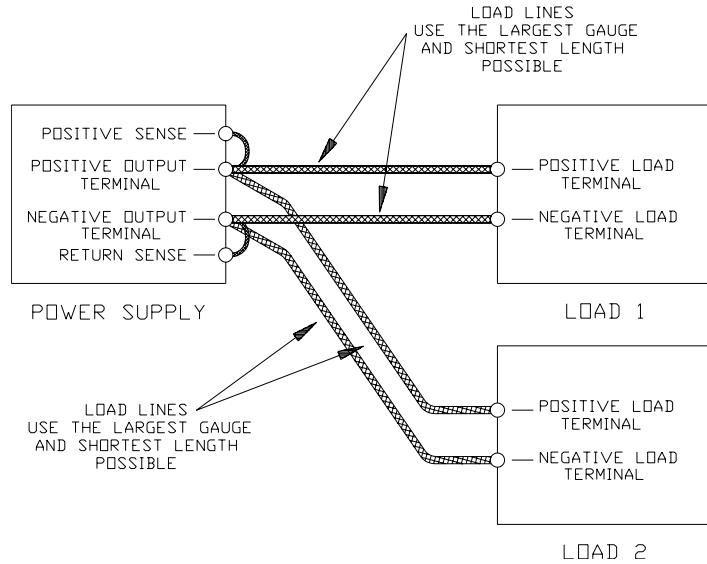

**Figure 2-9** Multiple Loads with Local Sensing

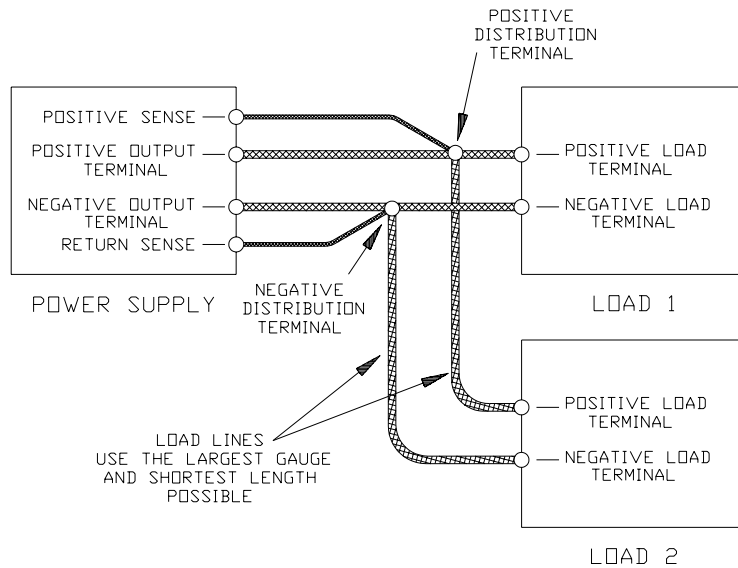

**Figure 2-10** Multiple Loads with Remote Sensing

---

## Local and Remote Sensing

Use connections at the rear panel J10 sense connector to configure the power supply for local or remote sensing of output voltage. See Figure 2-11 for a drawing of the sense connector.

### Sense Wiring



#### **WARNING: Shock hazard**

There is a potential shock hazard at the sense connector when using a power supply with a rated output greater than 40 V. Select wiring with a minimum insulation rating equivalent to the maximum output voltage of the power supply for use as local sense jumpers or for remote sense wires. For example, select TEW-105, 105 °C, 600 V wiring for use with a model 600 V, 4 A power supply. Ensure that connections at the load end are shielded to prevent contact with hazardous voltages.

---

For lowest noise performance, use shielded pair wiring of 16 to 24 AWG for remote sense lines. Strip wires 0.26 in. (6.5 mm) and insert securely as with any wire clamp connector.

### Local Sensing

We ship the power supply with the rear panel J10 sense connector jumpered for local sensing of the output voltage. See Table 2-5 for the list of connector functions and a description of local sense connections. With local sensing, the output voltage is regulated at the output terminals (or bus bars). This method does not compensate for voltage losses in the load lines, so it is recommended only for low current applications or applications for which precise load regulation is not essential.

Note: When using local sense connections, use the largest practical load wire size to minimize the effects of line impedance on the regulation of the supply.

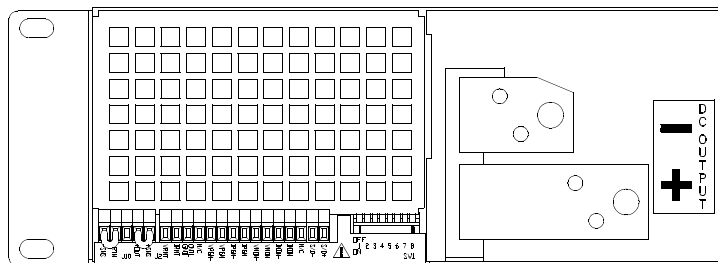

**Figure 2-11** J10 Sense Connector  
(Shown with local sense jumpers connected)

**Table 2-5** Rear Panel J10 Sense Connector Terminals and Functions

Terminal	Name	Function
J10-1	Return Sense (-SNS)	Remote negative sense connection. Default connection to terminal 2.
J10-2	Negative Output (Return or RTN)	Connected internally to negative bus bar.
J10-3	N/C	No connection.
J10-4	Positive Output (+OUT)	Connected internally to positive bus bar.
J10-5	Positive Sense (+SNS)	Remote positive sense connection. Default connection to terminal 4.



---

## Using Remote Sensing

---

**WARNING: Shock hazard**

There is a potential shock hazard at the sense points when using a power supply with a rated output greater than 40 V. Ensure that connections at the load end are shielded to prevent contact with hazardous voltages.

---

**WARNING: Shock hazard**

Ensure that the chassis ground screw does not penetrate more than 3/8 in. (9 mm) into the rear panel of the unit.

---

**CAUTION**

Ground the sense line shield in one place only. Locations include: the power supply's return output connection at the load, the power supply's return output at its negative output terminal, or the power supply's chassis.

---

**CAUTION**

Do not use remote sensing with multiple supplies connected in series.

---

Use remote sensing during voltage mode operation to shift the power supply's regulation point from its default position at the rear panel output terminals to the load or distribution terminals by using a separate pair of wires to allow the control circuitry to monitor the load voltage. This allows the power supply to compensate for voltage losses in the load lines which will otherwise degrade the regulation of the supply. Line drop is subtracted from the voltage available at the power supply's output.

To connect remote sense lines:

1. Turn OFF the power supply.
2. Remove the local sense jumpers connecting J10 mating connector terminal 5 (positive sense) to terminal 4 (positive output) and terminal 1 (return sense) to terminal 2 (power supply return).
3. Connect the positive remote sense lead to J10 mating connector terminal 5 (positive sense) and the negative lead to terminal 1 (return sense). Ensure that the mating connector is plugged securely into the rear panel sense connector. Connect the other ends of the sense wires to the corresponding sense points at the load.

4. To prevent ground loops, ground the sense line shield, at one point only, to the power supply's return output connection at the load, to the power supply's return output at its negative output terminal, or to the power supply's chassis.
5. Turn the power supply ON.

Notes:

1. If you operate the power supply with remote sense lines connected to the load and with either of the positive or negative load lines not connected, the power supply shutdown circuit will activate, causing the output voltage and current to fall to zero.
2. If you operate the power supply without remote sense lines or local sense jumpers in place, the supply will continue to work, but supply regulation will be degraded and/or erratic, or, the OVP circuit may activate.

Figure 2-12 shows a sample setup for using remote sensing.

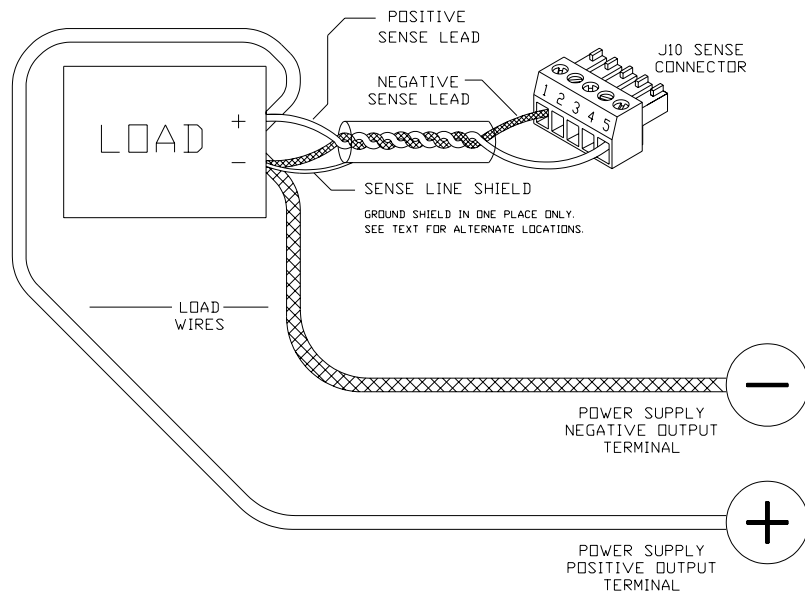

Figure 2-12 Connecting Remote Sense Lines

# 3

## Local Operation

Chapter 3 provides procedures for local (front panel) operation. It includes procedures for using over voltage protection, shutdown function, multiple supplies, and over temperature protection.

## Introduction

Once you have installed the power supply and have connected both the AC input power and the load as covered in Chapter 2, “Installation”, the power supply is ready to operate in local control mode (that is, operation at the unit’s front panel).

- See “Standard Operation” on page 3–3 for a brief explanation of Constant Voltage and Constant Current Mode operation and see page 3–7 to page 3–17 for more about power supply functions such as over voltage protection, shutdown function, over temperature protection, and using multiple supplies.
- See “User Diagnostics” on page 5–9 for troubleshooting information for the operator.
- Turn to Chapter 4, “Remote Operation” for descriptions of remote programming options and remote monitoring of the power supply.

## Standard Operation

This power supply has two basic operating modes: Constant Voltage Mode and Constant Current Mode, and two control modes: Local Control Mode (default setting) and Remote Programming Mode. Both operating modes are available regardless of which control mode is used.

### Operating Modes and Automatic Crossover

Whether controlled by local or remote programming, the power supply has two basic operating modes: Constant Voltage Mode and Constant Current Mode. The mode in which the power supply operates at any given time depends on the combination of:

- output voltage setting  $V_{SET}$
- output current limit setting  $I_{SET}$
- resistance of the attached load  $R_L$

See Figure 3-1 for a graphical representation of the relationships between these variables.

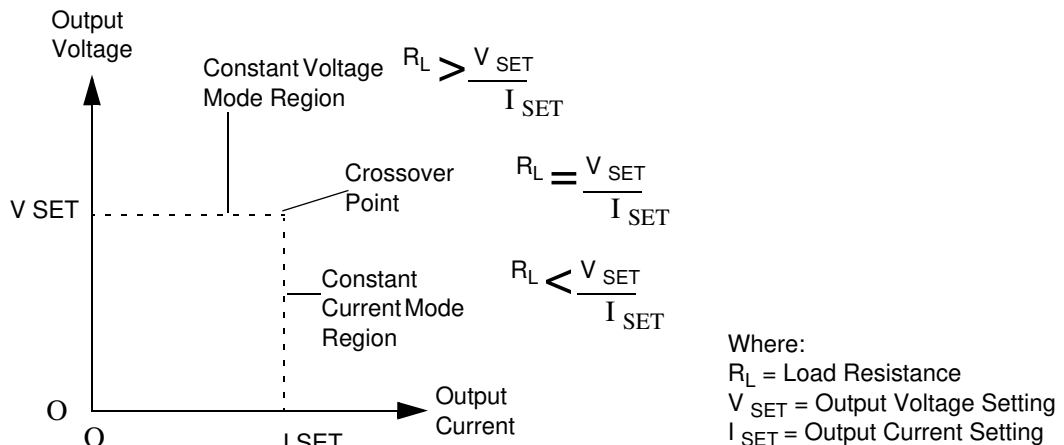

**Figure 3-1** Operating Modes

### Constant Voltage Mode Operation

The power supply will operate in constant voltage mode whenever the load current  $I_L$  **is less than** the current limit setting  $I_{SET}$ , or:  $I_L < I_{SET}$   
(Note:  $I_L = V_{SET} / R_L$ )

In constant voltage mode, the power supply maintains the output voltage at the selected value ( $V_{SET}$ ) while the load current  $I_L$  varies with the load requirements.

### Constant Current Mode Operation

The power supply will operate in constant current mode whenever the load resistance is low enough that the load current  $I_L$  **is equal to** the current limit setting  $I_{SET}$  (Note:  $V_L = I_{SET} R_L$ )

In constant current mode, the power supply maintains the output current at the selected value ( $I_{SET}$ ) while the load voltage varies with the load requirements.

### Automatic Mode Crossover

This feature allows the power supply to automatically switch operating modes in response to changing load requirements. If, for instance, the power supply was operating in Constant Voltage Mode ( $I_L < I_{SET}$ ), and the load changed so that the load current ( $I_L$ ) became **equal to** the current limit setting ( $I_{SET}$ ), the power supply would automatically switch into Constant Current Mode and the output voltage would vary in response to changes in load current. If the additional load was subsequently removed so that the load current was again **less than** the current limit setting, the supply would automatically return to Constant Voltage Mode.

## Shipped Configuration (Local Control Mode)

The factory ships units already configured for local control (front panel) operation. See Table 3-1 for a summary of this configuration. See Figure 1-4 on page 1-7 and Figure 1-2 on page 1-5 for front and rear panel diagrams.

**Table 3-1** Shipped Configuration (Local Control Mode)

Local Control Configuration	Additional References
Use the front panel controls to adjust the output voltage and current limit settings. (Note: Use the LOCAL button only when you have a digital programming interface installed.)	See Chapter 3 for front panel operation. See Chapter 4 for remote analog programming procedure(s).
The supply's sense point is at the rear panel J10 sense connector terminals.	See “Local and Remote Sensing” on page 2-21 for how to change from local to remote sensing.
The OVP set point is adjusted at the front panel to approximately 110% of rated output voltage.	See “Using Over Voltage Protection (OVP)” on page 3-7 for the adjustment procedure.
The over temperature shutdown function automatically resets when activated as determined by the position of rear panel switch SW1-8. A latch off setting is also available.	See “Over Temperature Protection (OTP)” on page 3-17 for more information about switch SW1-8 settings.

## Setting Output Voltage and Current Limit

Install the power supply and connect the load as described in “Installation”. Ensure that the power supply is set up for local control as described in “Shipped Configuration (Local Control Mode)” on page 3–5. Then, set the output voltage and current limit at the front panel with the following procedure.

1. Turn both the voltage and current controls fully counter-clockwise.
2. Turn the AC power ON.
3. Press the STANDBY switch to its IN position to disable the power supply output. The red Shutdown (S/D) LED turns on.
4. Press and hold the V/I CHECK button to display the voltage and current control settings on the voltmeter and ammeter displays.
5. Adjust the voltage control to the desired voltage (the compliance voltage for applications using current mode operation).
6. Adjust the current control to the desired current limit setting.
7. Release the V/I CHECK button.
8. Press the STANDBY switch to its OUT position to apply power to the load. The S/D LED turns off.

Note: The control circuits have been designed to allow you to set output voltage and current up to 5% over the model-rated maximum values. The power supply will operate within these extended ranges, but we cannot guarantee full performance to specification.



---

## Using Over Voltage Protection (OVP)

The OVP circuit protects the load in the event of a remote programming error, an incorrect voltage control adjustment, or a power supply failure. The protection circuit monitors the output voltage at the output of the power supply and will shut down the main power converter whenever a preset voltage limit is exceeded. Set the preset voltage limit (also called the set point or trip level) using the screwdriver-adjustable, front panel OVP potentiometer, or via one of the optional GPIB or RS-232 programming interfaces.

Notes:

1. The default preset limit is approximately 110% of the rated output voltage.
2. When using OVP with remote sensing lines connected, compensate for the voltage line drop across the output return line by measuring or calculating the line drop, then adding this value to the desired OVP setpoint.

### Front Panel OVP Operation

In local control mode, check the OVP set point at any time by pressing the OVP CHECK switch. The OVP set point is the value displayed on the digital voltmeter.

To set the trip level from the front panel:

1. Disconnect any loads. Turn the power supply ON.
2. Adjust the power supply output voltage to any voltage lower than the desired trip level.
3. Press the front panel STANDBY (output shutdown) switch to its IN position. The red S/D LED turns on.
4. Press the OVP CHECK switch to see the OVP set point on the voltmeter display.
5. Holding down the OVP CHECK switch, turn the OVP SET potentiometer until the desired set point is reached. Release the OVP CHECK switch.
6. Press the STANDBY switch to its OUT position. The S/D LED turns off.

7. To check that the power supply shuts off at the desired set point, slowly increase the output voltage while monitoring the front panel voltmeter. The OVP LED on the front panel turns on when the OVP circuit activates.

## Resetting the OVP Circuit

To reset the OVP circuit after it activates:

1. Reduce the power supply's output voltage setting to below the OVP set point.
2. Press the STANDBY switch IN. The red S/D LED on the front panel turns on. The OVP LED turns off.
3. Press the STANDBY switch again to return power to the load and resume normal operation.

OR

1. Reduce the power supply's output voltage setting to below the OVP set point.
2. Turn the power supply OFF using the AC power switch, wait until the front panel displays go out, then turn the power supply back ON again.

---

## Using the Shutdown Function

Use the Shutdown function to disable or enable the supply's output so that you can make adjustments to either the load or the power supply without shutting off the power supply. Activate this function from the front panel at any time by using the STANDBY switch. You can also activate it via remote control through the rear panel J2 Programming and Monitoring connector, using a 2.5 V to 15 V signal or a transistor-transistor logic (TTL) compatible signal. The input lines for the Shutdown circuit are optically isolated.

### STANDBY Switch

The STANDBY switch is a press ON/press OFF switch located on the power supply's front panel. See the front panel diagram in "Front Panel Controls" on page 1–3. Push the switch to its IN position to activate the Shutdown circuit. The output voltage and current fall to zero and the red S/D (Shutdown) LED turns on. Push the switch once more to reset it to its OUT position and resume normal power supply operation.

### Controlling the Shutdown Function via the J2 Connector

The shutdown circuit accepts a 2.5 V to 15 V signal to disable or enable the power supply output. Make connections for signals at connector J2, located on the unit's rear panel. Set rear panel switch SW1-7 to select signal logic. See "Front Panel Controls" on page 1–3 for more information about making J2 connector and SW1 switch changes.

To activate the shutdown function:

1. Turn OFF the power supply.
2. Connect the signal source to J2 connector terminal 15 (Shutdown Input/positive) and terminal 14 (Shutdown Return).
3. Set switch SW1-7 to select the desired circuit logic as set out in Table 3-2.
4. Turn on the power supply. The power supply will operate as described in the **Supply Output** column in Table 3-2, according to the logic you select and the level of the input signal. The S/D (Shutdown) LED on the front panel turns on when the Shutdown circuit is activated.

**Table 3-2** Switch Settings for Shutdown Circuit Logic

Switch SW1-7 Setting	Source Signal	Signal Level	Supply Output	S/D LED
OFF (OPEN) (Active low, default)	2-15 V	HIGH	OFF	ON
	0-0.4 V	LOW	ON	OFF
ON (CLOSED) (Active high)	2-15 V	HIGH	ON	OFF
	0-0.4 V	LOW	OFF	ON

## Notes:

1. If switch SW1-7 is ON but there is no signal applied, the S/D LED turns on and the power supply will not provide an output until the HIGH signal level is applied.
2. Any of the eight switches on SW1 is OFF (OPEN) when it has been flipped up to break contact, ON (CLOSED) when flipped down to close contact.

---

## Using Multiple Supplies

---



### WARNING

There is a shock hazard at the load when using a power supply with a rated *or combined* output greater than 40 V. To protect personnel against accidental contact with hazardous voltages created by series connection, ensure that the load, including connections, has no live parts which are accessible. Also ensure that the insulation rating of the load wiring and circuitry is greater than or equal to the maximum *or combined* output voltage of the power supply.

---



### CAUTION

Do not connect power supplies from different manufacturers in parallel or in series.

---



### CAUTION

The remote programming inputs are internally referenced to the supply's negative output. Do not connect remote programming ground lines (J2 terminals 3, 5, and 7) to the supply's positive output.

---

You can operate power supplies of the SAME MODEL with outputs in series or in parallel to obtain increased load voltage or increased current. Split supply operation gives you two positive outputs or a positive and a negative output.

Note: If your application requires the use of isolated programming inputs, contact the manufacturer about the optional ISOL Interface.

## Configuring Multiple Supplies for Series Operation



### CAUTION

Do not use remote sensing during series operation.



### CAUTION

The maximum allowable sum of the output voltages is 600 Vdc.

Use series operation to obtain a single higher voltage output using two or more supplies. Connect the negative (-) output terminal of one supply to the positive (+) output terminal of the next supply. See Figure 3-2. The total voltage available is the sum of the maximum voltages of each supply (add voltmeter readings, to a maximum of 600 V). The maximum allowable current for a series string of power supplies is the output current of a single supply in the string.

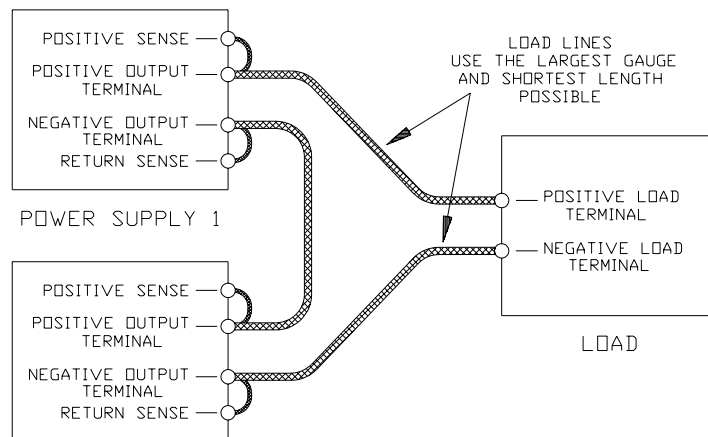

**Figure 3-2** Series Operation of Multiple Supplies

---

## Configuring Multiple Supplies for Parallel Operation

Use parallel operation to obtain a higher current through a single output using two or more supplies. Set all of the OVP setpoints to maximum. (See “Using Over Voltage Protection (OVP)” on page 3–7.) Set all of the outputs to the same voltage before connecting the positive (+) output terminals and negative (–) output terminals in parallel. See Figure 3-3. The total current available is the sum of the maximum currents of each supply.

When operating multiple supplies in parallel, the operating mode of each supply depends on the load current being drawn. For example, with two 40 V, 70 A power supplies operating in parallel with a 100 A load, one supply operates in constant current mode supplying 70 A and the other supply operates in voltage mode supplying the remaining 30 A. The level of current sharing between units depends on how accurately the output voltages are matched.

Note: If you do not fix the OVP setpoints at maximum, the OVP circuit may trip on one unit, reducing the current available to the load.

### Sensing for Parallel Operation

Use default local sensing to enhance power sharing between units, as the impedance of the load lines will tend to correct for current imbalance. If you use remote sensing at the load for better voltage regulation, one supply always operates in current limit mode and supplies most of the power.

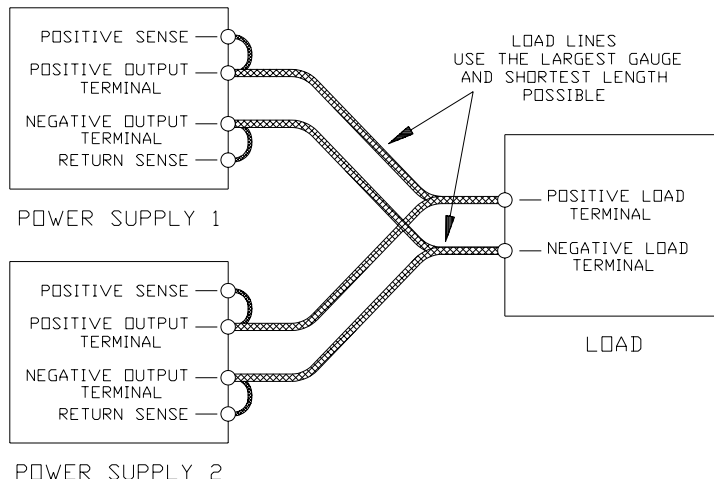

**Figure 3-3** Parallel Operation of Multiple Supplies  
(Local sense lines shown are default J10 connections.)



## Configuring Multiple Supplies for Split Supply Operation

Split supply operation uses two power supplies to obtain two positive voltages with a common ground, or to obtain a positive-negative supply.

### Two Positive Voltages

To obtain two positive voltages, connect the negative output terminals of both supplies together in a common connection. The positive output terminals will provide the required voltages with respect to the common connection. See Figure 3-4.

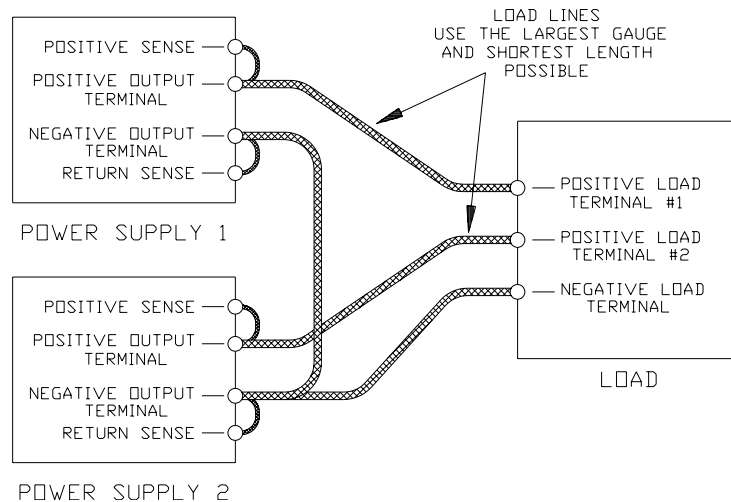

**Figure 3-4** Split Supply Operation of Multiple Supplies  
(Two Positive Voltages)  
(Local sense lines shown are default J10 connections.)

## Positive-negative Supply



### CAUTION

To prevent possible damage to the supply, do not connect the remote program return line of the negative supply to the common connection.

To obtain a positive-negative supply, connect the negative output terminal of one supply to the positive output terminal of the second supply. The positive output terminal of the first supply then provides a positive voltage relative to the common connection while the negative output terminal of the second supply provides a negative voltage. You can set the current limits independently. The maximum current available in split supply operation is equal to the rated output of the supplies. For example, 70 A for two 40 V, 70 A models. See Figure 3-5.

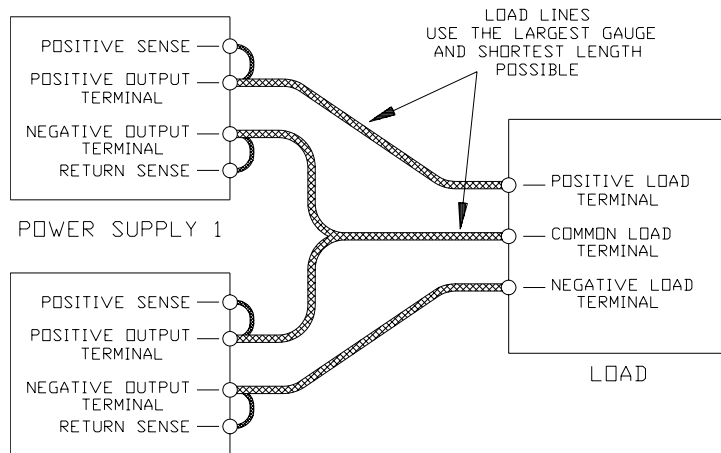

**Figure 3-5** Split Supply Operation of Multiple Supplies  
(Positive-negative Supply)  
(Local sense lines shown are default J10 connections.)

## Over Temperature Protection (OTP)

The OTP function allows you to select how the power supply recovers from an over temperature shutdown using the rear panel switch SW1-8. See Table 3-3 for switch settings and selections. See “Rear Panel Connectors and Switch” on page 1–5 for more information about the switch. The OTP shutdown circuit activates before the internal components can exceed their safe internal operating temperatures. When an OTP shutdown occurs, the front panel OTP LED turns on.

**Table 3-3** Switch Settings for Over Temperature Recovery Options

Switch SW1-8	OTP Shutdown Selection	Description
OFF (OPEN)	Auto Reset (Default)	The supply recovers to normal operation when the over temperature condition no longer exists.
ON (CLOSED)	Latch OFF	After an over temperature shutdown, the supply stays off until you turn the AC power switch OFF, then you turn the power supply ON to continue use.



# 4

## Remote Operation

Chapter 4 details remote analog programming operation and remote monitoring of output voltage and current.

## Introduction

The rear panel switches and connector on the power supply allow you to program the supply with an analog device or to output readback signals. This section covers the following topics:

- See “Remote Analog Programming of Output Voltage and Current Limit” on page 4–3 for information about remote analog programming of output voltage and current limit with 0-5 V and 0-10 V voltage sources and 0-5 k and 0-10 k resistances.
- See “Remote Monitoring of Output Voltage and Current” on page 4–7 for the connector and switch settings when using calibrated readback signals for output voltage and output current with selectable 0-5 V or 0-10 V scales.

### Isolated Programming

The four-channel Isolated (ISOL) Programming Interface is an internal card which is ordered as an option. It allows remote programming and readback of the power supply’s output voltage and current limit with 0-5V analog signals at a different potential relative to the power supply’s output. Contact the manufacturer to order.

### Remote Digital Programming

You can operate the power supply from a computer if you have had the GPIB or RS-232 Interface card installed as an option. Refer to the separate interface manual for all setup and operation instructions for remote digital programming.

## Remote Analog Programming of Output Voltage and Current Limit

Remote analog programming allows control of the power supply's output voltage and/or current limit to shift from local operation at the front panel voltage and current controls to external analog sources. As you vary the external programming source, the power supply's output varies proportionally over its output range.

Using remote analog programming requires that you reset switch SW1 and make connections to the J2 connector on the power supply's rear panel. See "Rear Panel Connectors and Switch" on page 1–5.

### Remote Programming Options

See Table 4-1 for a summary of the options available to you for programming output voltage and current limit using an analog source.

**Table 4-1** Remote Programming Options

Control of...	Programming Scales <sup>a</sup>
Output Voltage and/or Current Limit	0-5 V and 0-10 V voltage sources
	0-5 k and 0-10 k resistances

a. These scales may be used in any combination.

### Remote Analog Programming Procedure



#### CAUTION

To maintain the isolation of the power supply output and prevent ground loops, use an isolated (ungrounded) programming source when operating the power supply via remote analog control at the J2 connector.



#### CAUTION

The remote programming inputs are internally referenced to the supply's negative output. Do not connect control ground (J2 terminals 3, 5, or 7) to the supply's positive output.

**To set up remote analog programming:**

1. Turn the power supply OFF.
2. Using Table 4-2, set switches SW1-1, SW1-2, SW1-3, and SW1-4 according to the selected programming sources. See the Notes at the end of this procedure for more information about switch settings.
3. Install any J2 connector jumpers as indicated in Table 4-2.
4. Connect the programming source(s) to the mating J2 connector as shown in Figure 4-1 on page 4-6, observing the correct polarity for voltage sources. Ensure that the mating connector is plugged securely into the rear panel connector.
5. Set the programming sources to the desired levels and turn the power supply ON. The REM LED turns on.
6. Adjust the external programming source to change the power supply's output.

Notes:

1. Switches SW1 to SW4 can be set to their defaults (all open) unless otherwise specified in Table 4-2. Switches SW1-5, SW1-6, SW1-7, and SW1-8 are not required for remote programming. They can remain at the settings you have selected for your application.
2. Resetting switches SW1-3 or SW1-4, the programming scale selection switches, may require that you recalibrate the programming circuit to maintain programming accuracy. See Chapter 5.
3. Any of the eight switches on SW1 is OFF (OPEN) when it has been flipped up to break contact, ON (CLOSED) when flipped down to close contact.
4. The control circuits have been designed to allow you to set output voltage and current up to 5% over the model-rated maximum values. The power supply will operate within these extended ranges, but we cannot guarantee full performance to specification.



**Table 4-2** Power Supply Settings for Different Programming Sources

Output Voltage Programming Source	Output Current Limit Programming Source				
	0-5 Vdc	0-10 Vdc	0-5 k Resistor	0-10 k Resistor	None (Front Panel Control)
<b>0-5 Vdc</b>	SW1: set 3 and 4 open. J2: jumper 1 to 3 and 2 to 3.	SW1: set 3 open. J2: jumper 1 to 3 and 2 to 3.	SW1: set 2 closed, 3 and 4 open. J2: jumper 1 to 3 and 2 to 3.	SW1: set 2 closed, 3 open. J2: jumper 1 to 3 and 2 to 3.	SW1: set 3 open. J2: jumper 1 to 3.
<b>0-10 Vdc</b>	SW1: set 4 open. J2: jumper 1 to 3 and 2 to 3.	SW1: default settings. J2: jumper 1 to 3 and 2 to 3.	SW1: set 2 closed, 4 open. J2: jumper 1 to 3 and 2 to 3.	SW1: set 2 closed. J2: jumper 1 to 3 and 2 to 3.	SW1: default settings. J2: jumper 1 to 3.
<b>0-5 k Resistor</b>	SW1: set 1 closed, 3 and 4 open. J2: jumper 1 to 3 and 2 to 3.	SW1: set 1 closed, 3 open. J2: jumper 1 to 3 and 2 to 3.	SW1: set 1 and 2 closed, 3 and 4 open. J2: jumper 1 to 3 and 2 to 3.	SW1: set 1 and 2 closed, 3 open. J2: jumper 1 to 3 and 2 to 3.	SW1: set 3 open, 1 closed. J2: jumper 1 to 3.
<b>0-10 k Resistor</b>	SW1: set 1 closed, 4 open. J2: jumper 1 to 3 and 2 to 3.	SW1: set 1 closed. J2: jumper 1 to 3 and 2 to 3.	SW1: set 1 and 2 closed, 4 open. J2: jumper 1 to 3 and 2 to 3.	SW1: set 1 and 2 closed. J2: jumper 1 to 3 and 2 to 3.	SW1: set 1 closed. J2: jumper 1 to 3.
<b>None (Front Panel Control)</b>	SW1: set 4 open. J2: jumper 2 to 3.	SW1: default settings. J2: jumper 2 to 3.	SW1: set 2 closed, 4 open. J2: jumper 2 to 3.	SW1: set 2 closed. J2: jumper 2 to 3.	SW1: default settings. J2: no jumper.

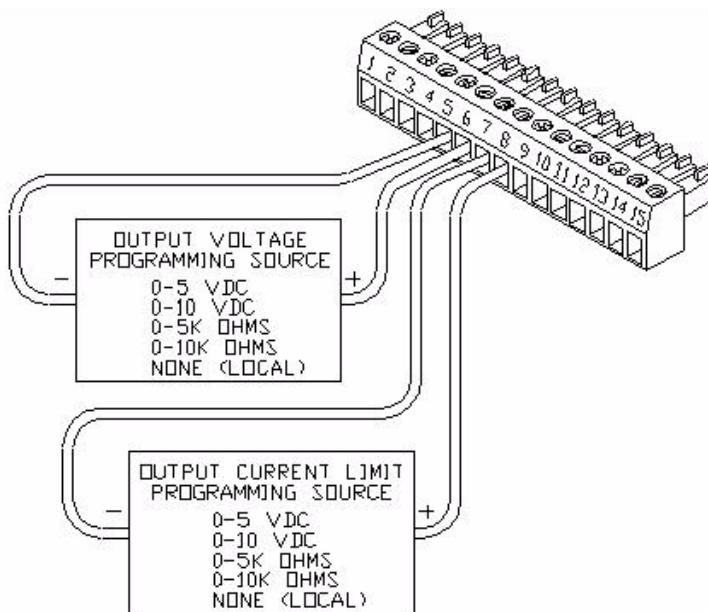

**Figure 4-1** Connecting Programming Sources to J2 Connector

## Remote Monitoring of Output Voltage and Current

### Readback Signals

The J2 connector on the rear panel provides access to calibrated readback signals for remote monitoring of the output voltage and current. Rear panel switches SW1-5 and SW1-6 allow you to select either a 0-5 Vdc or a 0-10 Vdc range for the output. The readback signal represents 0 to 100% of the power supply's output.

See Table 4-1 for the required J2 connections and switch settings for remote monitoring of readback signals with 0-5 Vdc or 0-10 Vdc outputs. Use shielded pair wiring (20 to 24 AWG) and ground the shield to J10 sense connector terminal 1 (return sense) or to the chassis.

**Table 4-3** Settings for Remote Monitoring of Readback Signals

Readback Signal	J2 Connection Signal (+)	J2 Connection Return (-)	Switch SW1 Setting
Output Voltage (0-5 Vdc)	J2-10	J2-9	SW1-5 OFF (OPEN)
Output Voltage (0-10 Vdc)	J2-10	J2-9	SW1-5 ON (CLOSED)
Output Current (0-5 Vdc)	J2-12	J2-11	SW1-6 OFF (OPEN)
Output Current (0-10 Vdc)	J2-12	J2-11	SW1-6 ON (CLOSED)

Note: Check the readback accuracy any time you reset switches SW1-5 and SW1-6. See Chapter 5.



# 5

## **Calibration and Troubleshooting**

Chapter 5 details remote analog programming operation and remote monitoring of output voltage and current. It also provides troubleshooting information.



### **WARNING: Shock hazard**

Exercise caution when using and calibrating a power supply. High energy levels can be stored at the output voltage terminals on a power supply in normal operation. In addition, potentially lethal voltages exist in the power circuit and on the output and sense connectors of a power supply with a rated output greater than 40 V. Filter capacitors store potentially dangerous energy for some time after power is removed.

---

Adjustments to programming and readback accuracy for the power supply are made using cover-off procedures which must be performed by a service technician.

## **Calibration Setup**

### **Service Environment and Precautions**

- Follow established antistatic procedures.
- Work at a bench with adequate room and support for the unit under test and for all equipment required.
- To reduce shock hazard, use only an insulated, straight-blade screwdriver when calibrating trim potentiometers.
- NEVER calibrate these units alone. Ensure that someone is present who can help should an accident occur.

### **Equipment Required**

You will need the following equipment when calibrating your power supply.

- 5 1/2 digit true RMS voltmeters (DVMs) ( $\pm 0.05\%$  accuracy) with test leads
- Current shunt 1 mV/A ( $\pm 0.25\%$ ) and connecting wire. The recommended current ratings for the DC shunt and connecting wire must be at least 10% greater than the power supply's output current rating. Please see Table 2-4 on page 2-13.
- Non-conducting, straight-bladed screwdriver

---

## Accessing Calibration Potentiometers

---

**WARNING: Shock hazard**

Disconnect AC power from the unit before removing the cover. Even when the front panel power switch is in the OFF position, live line voltages are exposed when the cover is removed. Repairs and adjustments must be made by experienced service technicians only.

---

**WARNING: Shock hazard**

Use a non-conducting, straight-blade screwdriver to adjust the trim pots.

---

**CAUTION**

Follow established antistatic procedures. There are static-sensitive parts on the printed circuit boards.

---

You will need to remove the power supply's cover to access the programming and readback calibration potentiometers which are located on the A2 PCB. See Figure 5-1 to locate the potentiometers.

### Removing Option Card

If there is a GPIB or RS-232 option card (PCB) installed inside the power supply, you will have to remove it to access the calibration potentiometers.

Tool Required: Phillips #2 screwdriver

1. Turn OFF the power supply. Disconnect AC Power. Remove the cover.
2. Remove 4 screws from their standoffs inside the power supply to release the option card.
3. Remove 2 screws at the rear panel to release the option card's sub-plate.
4. Unplug the ribbon cable connectors from the option card. Lift out card.
5. Remove the four screws holding the option card support plate and remove the plate.

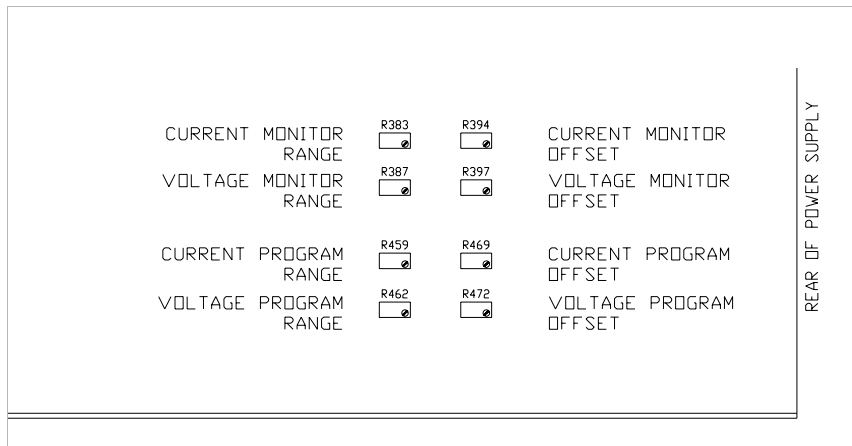

**Figure 5-1** Programming and Monitoring Calibration Locations  
(Top view)



## Calibrating for Programming Accuracy

The factory calibrates the offset and range of the voltage and current programming circuits to within 1% for the default 0-10 Vdc programming signals. You may need to recalibrate when you use 0-5 Vdc programming or when you switch back to 0-10 Vdc programming after previously calibrating for 0-5 Vdc programming.

See “Calibration Setup” on page 5–2 for instructions to remove the cover and any option card. Follow all procedure steps in the sequence given.

### Voltage Programming Circuit Calibration

**To perform voltage programming circuit calibration:**

1. Ensure that the power supply is turned OFF. Disconnect any load.
2. Connect the program source between J2 connector terminals 6 (output voltage program input) and 5 voltage program signal return).
3. Connect the DVM across the power supply output.
4. Turn the power supply ON.
5. Apply 1% of program voltage.
6. Adjust the voltage program offset potentiometer (R472) until the DVM reads 1% of the model-rated output voltage.
7. Apply 100% of program voltage.
8. Adjust the voltage program range potentiometer (R462) until the DVM reads the model-rated output voltage.

Repeat this procedure until output levels are adjusted to power supply specifications (see Appendix A, “Specifications”) or to the accuracy that your application requires.

## Current Limit Programming Circuit Calibration

### To perform current limit programming circuit calibration:

1. Ensure that the power supply is turned OFF. Disconnect any load.
2. Connect the program source between J2 connector terminals 8 (output current limit programming input) and 7 (current program signal return).
3. Connect the shunt and DVM across the power supply output.
4. Turn the power supply ON.
5. Apply 1% of program voltage.
6. Adjust the current limit program offset (R469) until the shunt/DVM indicates 1% of the model-rated output current. See Note.
7. Apply 100% of program voltage.
8. Adjust the current limit program range (R459) until the shunt/DVM indicates the model-rated output current. See Note.

Repeat this procedure until output levels are adjusted to power supply specifications (see Appendix A, “Specifications”) or to the accuracy that your application requires.

Note: Calculate the required DVM reading using  $V = IR$  where V is the DVM reading, I is the current, and R is the DC shunt resistance.

---

## Calibrating for Readback Accuracy

The factory calibrates the offset and range of the output voltage and current monitor circuits to within 1% for the default 0-10 Vdc scales. You may need to recalibrate when you select the 0-5 Vdc scale or when you switch back to the 0-10 Vdc scale after previously calibrating for 0-5 Vdc operation.

See “Calibration Setup” on page 5–2 for instructions to remove the cover and any option card. Follow all procedure steps in the sequence given.

### Output Voltage Monitor Circuit Calibration

**To perform output voltage monitor circuit calibration:**

1. Ensure that the power supply is turned OFF. Disconnect any load.
2. Set SW1 switch 5 OPEN to select 0-5 V output voltage monitor range, CLOSED for 0-10 V.
3. Connect a DVM across the power supply output to read the output voltage. Connect a second DVM between the rear panel J2 connector terminals 10 (output voltage monitor) and 9 (voltage monitor signal return).
4. Turn the power supply ON.
5. Set the power supply output voltage to 1% of the model-rated output.
6. Adjust the output voltage monitor offset (R397) until the monitor DVM reads 1% of the readback scale. (50 mVdc for 0-5 V readback or 100 mVdc for 0-10 Vdc readback.)
7. Set the power supply output voltage to the model-rated maximum.
8. Adjust the output voltage monitor range (R387) until the monitor DVM reads 100% of the readback scale. (5 Vdc for 0-5 V readback or 10 Vdc for 0-10 Vdc readback.)

Repeat this procedure until the monitor signal is adjusted to power supply specifications (see Appendix A, “Specifications”) or to the accuracy that your application requires.

## Output Current Monitor Circuit Calibration

### To perform output current monitor circuit calibration:

1. Ensure that the power supply is turned OFF. Disconnect any load.
2. Set SW1 switch 6 OPEN to select 0-5 V output current monitor range, CLOSED for 0-10 V.
3. Connect the shunt and DVM across the power supply output to read the output current. Connect a second DVM between the rear panel J2 connector terminals 12 (output current monitor) and 11 (current monitor signal return).
4. Turn the current control fully counter clockwise, then turn on the power supply.
5. Set the power supply's output current to 1% of the model-rated output. See Note.
6. Adjust the output current monitor offset (R394) until the monitor DVM indicates 1% of the readback scale. (50 mVdc for 0-5 V readback or 100 mVdc for 0-10 Vdc readback.)
7. Set the power supply output current to the model-rated output.
8. Adjust the output current monitor range (R383) until the monitor DVM indicates 100% of the readback scale. (5 Vdc for 0-5 V readback or 10 Vdc for 0-10 Vdc readback.)

Repeat this procedure until the monitor signal is adjusted to power supply specifications (see Appendix A, "Specifications") or to the accuracy that your application requires.

Note: Calculate the required DVM reading using  $V = IR$  where V is the DVM reading, I is the current, and R is the DC shunt resistance.

## User Diagnostics

If your power supply is not performing as described in this operating manual, run through the procedures and checks in this section before calling your service technician. These procedures are confined to operator-level functions only and do not require cover-off servicing.

### Emergency Shutdown

**In an emergency, carry out both of these steps:**

1. Shut the power supply OFF immediately.
2. Disconnect the power supply from the load.

### Unusual or Erratic Operation

**If the power supply displays any unusual or erratic operation, follow these steps:**

1. Shut the power supply OFF immediately.
2. Disconnect the power supply from the load.
3. Test the power supply with no load, running the tests in “Functional Tests” on page 2–9.
4. If the tests show that the power supply is functioning normally, check all load, programming, and monitoring connections and circuits.
5. Check the AC input for correct voltage and frequency.

If the problem is not solved after following this procedure, or if the unit fails to operate correctly upon retesting, call your service technician.

Turn to the next page for more information about troubleshooting for operators.

## Troubleshooting for Operators

Use the checks in Table 5-1 to ensure that the power supply is configured and connected for normal operation.

### Abbreviated References Used in Table

ACF	AC Fail
OTP	over temperature protection
OVP	over voltage protection
REM	remote mode
S/D	shutdown

**Table 5-1** User Diagnostics

Symptom	Check	Further Checks and Corrections
No output and the display is blank.	Is input voltage within specified range?	Connect to appropriate voltage source. See page 2–6.
	Power switch ON?	Turn on power.
	Internal circuit?	See your service technician.
No output but the display turns on.	OVP LED turned on?	See page 3–7.
	Front panel S/D LED turned on?	See page 3–9.
	OTP LED turned on?	See page 3–17.
	Current limit set to zero?	See page 3–6.
	Voltage control set to zero?	See page 3–6.
	REM LED turned on?	If using remote analog control, check your analog programming source (Chapter 4). If not, refer to your digital interface manual.
	Is front panel ACF LED turned on?	Connect unit to AC supply in specified range. See page 2–6.
	Internal circuit.	See your service technician.

**Table 5-1** User Diagnostics

Symptom	Check	Further Checks and Corrections
Output not adjustable.	Is unit in current limit mode? (Red Current Mode LED turned on.)	Turn current knob clockwise to increase current limit. Reduce load if current is at maximum. See page 3–6.
	Is unit in remote mode? (Green REM LED turned on.)	If using remote analog control, check your analog programming source (Chapter 4). If not, refer to your digital interface manual.
	Is unit at maximum voltage or current limit?	Reduce load for lower voltage or current requirement.
Output voltage fluctuating or regulation poor.	Is unit at current limit?	Increase current limit setting or reduce load. See page 3–6.
	Is input voltage within specified range?	Connect to appropriate AC voltage source. See page 2–6.
	Are sense lines connected?	See page 2–9 and page 2–18.
	Is unit under remote analog control?	Ensure that program source is stable.
	Internal circuit.	See your service technician.
Output oscillating.	Internal circuit.	See your service technician.





# A

## Specifications

Appendix A contains electrical, mechanical and environmental specifications and characteristics of the XFR 2800 Watt Series Programmable DC Power Supply.

These specifications are warranted over a temperature range of 0 °C to 50 °C.

Nominal ambient temperature assumed is 25 °C.

Nominal line voltages are 120 Vac and 230 Vac.

See Table A-1 and Table A-2 for maximum values for model-dependent specifications.

Specifications are subject to change without notice.

## Electrical Specifications

These specifications are warranted over a temperature range of 0 °C to 50 °C.

Nominal ambient temperature assumed is 25 °C.

Nominal line voltage is 208 Vac, 60 Hz.

See Table A-1 and Table A-2 for maximum values for model-dependent specifications.

Specifications are subject to change without notice.

**Table A-1** Specifications for 7.5 V to 40 V Models

Models	7.5-300	12-220	20-130	33-85	40-70
Output Ratings:					
Output Voltage <sup>a</sup>	0-7.5 V	0-12 V	0-20 V	0-33 V	0-40 V
Output Current <sup>b</sup>	0-300 A	0-220 A	0-130 A	0-85 A	0-70 A
Output Power	2250 W	2640 W	2600 W	2805 W	2800 W
Line Regulation: <sup>c</sup>					
Voltage (0.01% of V <sub>max</sub> + 2 mV)	2.75 mV	3.2 mV	4 mV	5.3 mV	6 mV
Current (0.01% of I <sub>max</sub> + 2 mA)	32 mA	24 mA	15 mA	10.5 mA	9 mA
Load Regulation: <sup>d</sup>					
Voltage (0.02% of V <sub>max</sub> + 5 mV)	6.5 mV	7.4 mV	9 mV	11.6 mV	13 mV
Current (0.02% of I <sub>max</sub> + 5 mA)	65 mA	49 mA	31 mA	22 mA	19 mA
Meter Accuracy:					
Voltage (1% of V <sub>max</sub> + 1 count)	0.09 V	0.13 V	0.3 V	0.43 V	0.5 V
Current (1% of I <sub>max</sub> + 1 count)	4 A	2.3 A	1.4 A	0.95 A	0.8 A
Output Noise (0-20 MHz):					
Voltage (p-p)	100 mV	100 mV	100 mV	100 mV	150 mV
Output Ripple (rms):					
Voltage	10 mV	10 mV	10 mV	15 mV	15 mV
Current <sup>e</sup>	1600 mA	1200 mA	400 mA	300 mA	200 mA
Drift (30 minutes): <sup>f</sup>					
Voltage (0.07% of V <sub>max</sub> )	3.75 mV	6 mV	10 mV	16.5 mV	20 mV
Current (0.7% of I <sub>max</sub> )	2100 mA	1540 mA	910 mA	595 mA	490 mA
For Resistive Programming:					
Voltage (0.6% of V <sub>max</sub> )	45 mV	72 mV	120 mV	198 mV	240 mV
Current (0.6% of I <sub>max</sub> )	1800 mA	1320 mA	780 mA	510 mA	420 mA

**Table A-1** Specifications for 7.5 V to 40 V Models

Models	7.5-300	12-220	20-130	33-85	40-70
Drift (8 hours): <sup>g</sup>					
Voltage (0.05% of Vmax)	3.75 mV	6 mV	10 mV	16.5 mV	20 mV
Current (0.05% of Imax)	150 mA	110 mA	65 mA	42.5 mA	35 mA
For Resistive Programming:					
Voltage (0.3% of Vmax)	22.5 mV	36 mV	60 mV	99 mV	120 mV
Current (0.3% of Imax)	900 mA	660 mA	390 mA	255 mA	210 mA
Temperature Coefficient: <sup>h</sup>					
Voltage (0.02% of Vmax/°C)	1.5 mV	2.4 mV	4 mV	6.6 mV	8 mV
Current (0.03% of Imax/°C)	90 mA	66 mA	39 mA	25.5 mA	21 mA
For Resistive Programming:					
Voltage (0.06% of Vmax/°C)	4.5 mV	7.2 mV	12 mV	19.8 mV	24 mV
Current (0.06% of Imax/°C)	180 mA	132 mA	78 mA	51 mA	42 mA
OVP Adjustment Range: (5% to 110% of Vmax)	0.375- 8.25 V	0.6-13.2 V	1-22 V	1.65- 36.3 V	2-44 V
Efficiency: <sup>i</sup>	0.80	0.82	0.85	0.85	0.87

- a. Minimum output voltage is <0.15% of rated voltage at zero output setting.
- b. Minimum output current is <0.5% of rated current at zero output setting when measured at minimum 10% of full power load.
- c. For input voltage variation over the AC input voltage range, with constant rated load.
- d. For 0-100% load variation, with constant nominal line voltage.
- e. Current mode noise is measured from 10% to 100% of rated output voltage, full current.
- f. Maximum drift over 30 minutes with constant line, load, and temperature, after power on.
- g. Maximum drift over 8 hours with constant line, load, and temperature, after 30-minute warm-up.
- h. Change in output per °C change in ambient temperature, with constant line and load.
- i. Typical efficiency at nominal input voltage and full output power.

**Table A-2** Specifications for 60 V to 600 V Models

<b>Models</b>	<b>60-46</b>	<b>100-28</b>	<b>150-18</b>	<b>300-9</b>	<b>600-4</b>
Output Ratings:					
Output Voltage <sup>a</sup>	0-60 V	0-100 V	0-150 V	0-300 V	0-600 V
Output Current <sup>b</sup>	0-46 A	0-28 A	0-18 A	0-9 A	0-4 A
Output Power	2760 W	2800 W	2700 W	2700 W	2400 W
Line Regulation: <sup>c</sup>					
Voltage (0.01% of Vmax + 2 mV)	8 mV	12 mV	17 mV	32 mV	62 mV
Current (0.01% of Imax + 2 mA)	6.6 mA	4.8 mA	3.8 mA	2.9 mA	2.4 mA
Load Regulation: <sup>d</sup>					
Voltage (0.02% of Vmax + 5 mV)	17 mV	27 mV	35 mV	65 mV	125 mV
Current (0.02% of Imax + 5 mA)	14.2 mA	10.6 mA	8.6 mA	6.8 mA	5.8 mA
Meter Accuracy:					
Voltage (1% of Vmax + 1 count)	0.7 V	1.1 V	1.6 V	4 V	7 V
Current (1% of Imax + 1 count)	0.56 A	0.38 A	0.19 A	0.1 A	0.05 A
Output Noise (0-20 MHz):					
Voltage (p-p)	150 mV	175 mV	200 mV	400 mV	500 mV
Output Ripple (rms):					
Voltage	15 mV	25 mV	25 mV	40 mV	100 mV
Current <sup>e</sup>	100 mA	80 mA	40 mA	20 mA	10 mA
Drift (30 minutes): <sup>f</sup>					
Voltage (0.05% of Vmax)	30 mV	50 mV	75 mV	150 mV	300 mV
Current (0.7% of Imax)	322 mA	196 mA	126 mA	63 mA	28 mA
For Resistive Programming:					
Voltage (0.6% of Vmax)	360 mV	600 mV	900 mV	1800 mV	3600 mV
Current (0.6% of Imax)	276 mA	168 mA	108 mA	54 mA	24 mA
Drift (8 hours): <sup>g</sup>					
Voltage (0.05% of Vmax)	30 mV	50 mV	75 mV	150 mV	300 mV
Current (0.05% of Imax)	23 mA	14 mA	9 mA	4.5 mA	2 mA
For Resistive Programming:					
Voltage (0.3% of Vmax)	180 mV	300 mV	450 mV	900 mV	1800 mV
Current (0.3% of Imax)	138 mA	84 mA	54 mA	27 mA	12 mA

**Table A-2** Specifications for 60 V to 600 V Models

Models	60-46	100-28	150-18	300-9	600-4
Temperature Coefficient: <sup>h</sup>					
Voltage (0.02% of Vmax/°C)	12 mV	20 mV	30 mV	60 mV	120 mV
Current (0.03% of I <sub>max</sub> /°C)	13.8 mA	8.4 mA	5.4 mA	2.7 mA	1.2 mA
For Resistive Programming:					
Voltage (0.06% of Vmax/°C)	36 mV	60 mV	90 mV	180 mV	360 mV
Current (0.06% of I <sub>max</sub> /°C)	28 mA	16.8 mA	10.8 mA	5.4 mA	2.4 mA
OVP Adjustment Range: (5% to 110% of V <sub>max</sub> )	3-66 V	5-110 V	7.5-165 V	15-330 V	30-660 V
Efficiency: <sup>i</sup>	0.90	0.90	0.90	0.91	0.91

- a. Minimum output voltage is <0.15% of rated voltage at zero output setting.
- b. Minimum output current is <0.5% of rated current at zero output setting when measured at minimum 10% of full power load.
- c. For input voltage variation over the AC input voltage range, with constant rated load.
- d. For 0-100% load variation, with constant nominal line voltage.
- e. Current mode noise is measured from 10% to 100% of rated output voltage, full current.
- f. Maximum drift over 30 minutes with constant line, load, and temperature, after power on.
- g. Maximum drift over 8 hours with constant line, load, and temperature, after 30-minute warm-up.
- h. Change in output per °C change in ambient temperature, with constant line and load.
- i. Typical efficiency at nominal input voltage and full output power.

---

## Additional Specifications

Rise Time (No Load, Full Load): <sup>a</sup>	7.5 V to 60 V models: 100 ms; 100 V to 600 V models: 170 ms
Fall Time (No Load): <sup>a</sup>	4 s
Fall Time (Full Load): <sup>a</sup>	7.5 V to 60 V models: 100 ms; 100 V to 600 V models: 170 ms
Voltage Mode Transient Response: <sup>b</sup>	<3 ms
Time Delay from power on until output stable	7 s maximum

- a. Measured with stepped 0-10 V analog programming source and a resistive load.
- b. Time for the output voltage to recover within 0.5% of its rated value after a step change in load current of 10% to 90% of rated output with an output setpoint between 50-100% of rated value. Load slew rate <6 A/ms.

# Input Conditions

Rated AC Input Voltage	200/208/220/230/240 Vac (nominal)
Maximum AC Input Power	5000 VA
Operational AC Input Voltage	190-264 Vac, 1 $\phi$ (24.3 A maximum at 208 Vac; 22.4 A maximum at 230 Vac.) Auto range select function.
Input Frequency Range	47-63 Hz
Power Factor	0.65 typical

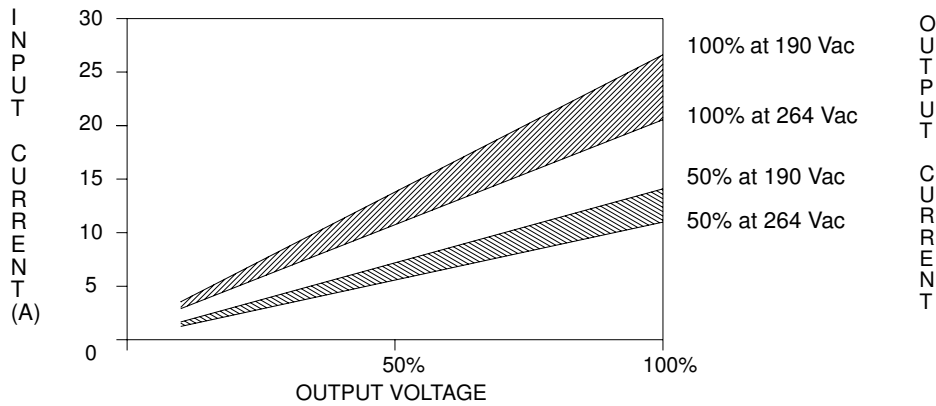

**Figure A-1** Typical Input Current Characteristics  
(Based on 100 V, 28 A model.)

## Additional Features

Switching Frequency	nominal 31 kHz (62 kHz output ripple).
Output Hold-up Time	Greater than 10 ms with interruption of AC line, for nominal AC input and full load.
Maximum Voltage Differential from either output to safety ground	$\pm 600$ Vdc
Insulation Resistance	Input to chassis: $>30$ M $\Omega$ , with 500 Vdc; Output to chassis: $>20$ M $\Omega$ , with 1000 Vdc.
Isolation Voltage	Input to output: 1350 Vac

## Remote Programming and Monitoring

Remote Start/Stop and Interlock	2.5-15 V signal or TTL-compatible input, selectable logic. TTL input impedance: 2 k (in series with one diode drop).
Remote Analog Programming (Full Scale Input)	Voltage and current programming inputs (source must be isolated): 0-5 k, 0-10 k resistances; 0-5 V, 0-10 V (default) voltage sources. Input impedance (V and I): approximately 100 k.
Remote Monitoring	Output voltage and current: 0-5 V, 0-10 V (default); Output impedance (V and I): approx 221 $\Omega$ . Output short circuit current: approx. 50 mA.
Remote Programming and Monitoring Accuracy	1% zero to full scale output for the default range.
Maximum Remote Sense Line Drop Compensation	5 V/line (Line drop is subtracted from total voltage available at supply output.)
Optional Isolated Program and Readback (V&I)	0-5 V (ISOL interface); input impedance: 200 k; output impedance: 221 $\Omega$
Optional Digital Control	RS-232, GPIB interfaces



---

## Environmental Specifications

Operating Temperature Range	0 °C to 50 °C.
Storage Temperature Range	-20 °C to +70 °C
Humidity Range	30% to 90% RH non-condensing
Operating Altitude	Up to 6,500 feet (2000 m)
Storage Altitude	Up to 50,000 feet (15 000 m)
Installation Category	Intended for use in installation category (over voltage category) II (IEC 1010-1 standard).
Pollution Degree	Category 2 (IEC 1010-1 standard).

## Mechanical Specifications

Front Panel V and I Control	10-turn voltage and current potentiometers
Front Panel Voltage Control Resolution	0.02% of maximum voltage
Front Panel Voltage and Current Meters	3.5-digit green numeric LED displays. For accuracy specifications, see Table A-1 on page A-2 and Table A-2 on page A-4.
AC Input Connector Type	3-terminal 34 A, 250 V, right angle, PC mount, wire clamp connector with removable strain relief cover
Input Fuses <sup>a</sup>	1 A, 250 V, 5 x 20 mm slow fuse (T), location: F34; 1.5 A, 250 V, 5 x 20 mm time delay (T), location: F33; 20 A, 250 Vac, 5 x 20 mm fast high interrupt (F), location: F36; 30 A, 300 Vac, 10.3 x 41.3 mm medium time lag (T), locations: F2, F3.
Output Connector	7.5 V to 100 V models: nickel-plated copper bus bars with removable bus bar shield; bus bar holes: 0.343 in. (8.7 mm) diameter (D) (1), 0.197 in. (5.0 mm) D (2); 150 V to 600 V models: 4-terminal, right angle, PC mount, wire clamp connector with removable strain relief cover.
Sense Connector	5-terminal wire clamp connector (2 piece)
Analog Programming Connector	15-terminal wire clamp connector (2 piece)
Chassis Ground	One chassis ground screw located on rear panel for bonding connections or for wire shield grounding. Maximum penetration into unit is 0.375 in. (9 mm).
Cooling	Fan cooled. Air exhausts to rear. Over temperature shutdown: automatic restart or latch off (switch-selectable).

Mounting	Rack mount brackets. Mount at front panel.
Weight	Approximately 33lb. (15 kg)
Approvals	CE mark: Meets EMC standards EN50081-2 and EN50082-2 and safety standard IEC1010-1 c(UL)us: UL certified to UL3111-1, 1st edition and to CAN/CSA C22.2 No. 1010.1-92 FCC: Meets Class A limits of Part 15 subpart B

- a. Fuses are located on the A4 PCB (printed circuit board). The fuses are NOT operator-replaceable.

# Specifications

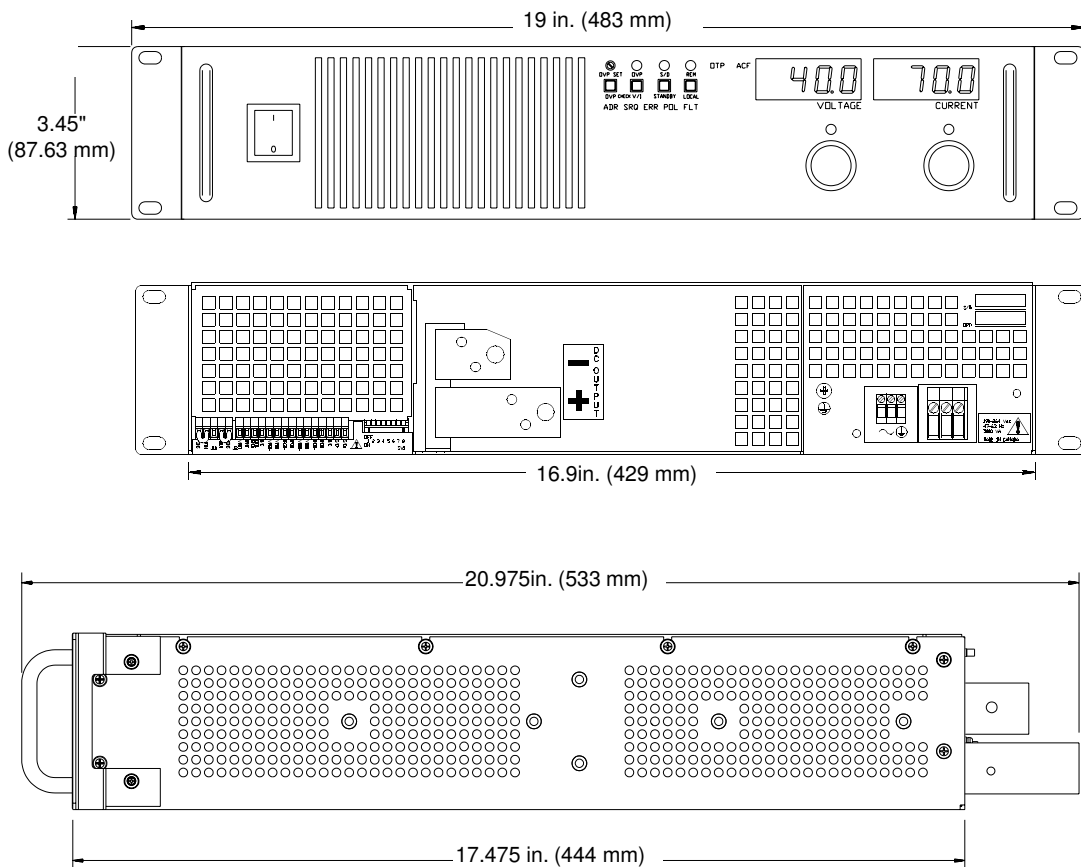

**Figure A-2** Dimensional Drawings

# Warranty and Return Information

## Warranty

**What does this warranty cover?** This Limited Warranty is provided by Xantrex Technology Inc. ("Xantrex") and covers defects in workmanship and materials in your XFR 2800 Watt Series Programmable DC Power Supply. This warranty period lasts for five (5) years from the date of purchase at the point of sale to you, the original end user customer. You require proof of purchase to make warranty claims.

**What will Xantrex do?** Xantrex will, at its option, repair or replace the defective product free of charge, provided that you notify Xantrex of the product defect within the Warranty Period, and provided that Xantrex through inspection establishes the existence of such a defect and that it is covered by this Limited Warranty.

Xantrex will, at its option, use new and/or reconditioned parts in performing warranty repair and building replacement products. Xantrex reserves the right to use parts or products of original or improved design in the repair or replacement. If Xantrex repairs or replaces a product, its warranty continues for the remaining portion of the original Warranty Period or 90 days from the date of the return shipment to the customer, whichever is greater. All replaced products and all parts removed from repaired products become the property of Xantrex.

Xantrex covers both parts and labor necessary to repair the product, and return shipment to the customer via a Xantrex-selected non-expedited surface freight within the contiguous United States and Canada. Alaska and Hawaii are excluded. Contact Xantrex Customer Service for details on freight policy for return shipments outside of the contiguous United States and Canada.

**How do you get service?** If your product requires troubleshooting or warranty service, contact your merchant. If you are unable to contact your merchant, or the merchant is unable to provide service, contact Xantrex directly at:

Telephone: 1 800 733 5427(toll free North America)  
                  1 858 450 0085 (direct)  
Fax:              1 858 678 4482 (direct)  
Email:          prg.info@xantrex.com

Direct returns may be performed according to the Xantrex Return Material Authorization Policy described in your product manual. For some products, Xantrex maintains a network of regional Authorized Service Centers. Call Xantrex or check our website to see if your product can be repaired at one of these facilities.

## Warranty and Return

---

**What proof of purchase is required?** In any warranty claim, dated proof of purchase must accompany the product and the product must not have been disassembled or modified without prior written authorization by Xantrex.

Proof of purchase may be in any one of the following forms:

- The dated purchase receipt from the original purchase of the product at point of sale to the end user, or
- The dated dealer invoice or purchase receipt showing original equipment manufacturer (OEM) status, or
- The dated invoice or purchase receipt showing the product exchanged under warranty

**What does this warranty not cover?** This Limited Warranty does not cover normal wear and tear of the product or costs related to the removal, installation, or troubleshooting of the customer's electrical systems. This warranty does not apply to and Xantrex will not be responsible for any defect in or damage to:

- a) the product if it has been misused, neglected, improperly installed, physically damaged or altered, either internally or externally, or damaged from improper use or use in an unsuitable environment;
- b) the product if it has been subjected to fire, water, generalized corrosion, biological infestations, or input voltage that creates operating conditions beyond the maximum or minimum limits listed in the Xantrex product specifications including high input voltage from generators and lightning strikes;
- c) the product if repairs have been done to it other than by Xantrex or its authorized service centers (hereafter "ASCs");
- d) the product if it is used as a component part of a product expressly warranted by another manufacturer;
- e) the product if its original identification (trade-mark, serial number) markings have been defaced, altered, or removed.

## Disclaimer

### Product

THIS LIMITED WARRANTY IS THE SOLE AND EXCLUSIVE WARRANTY PROVIDED BY XANTREX IN CONNECTION WITH YOUR XANTREX PRODUCT AND IS, WHERE PERMITTED BY LAW, IN LIEU OF ALL OTHER WARRANTIES, CONDITIONS, GUARANTEES, REPRESENTATIONS, OBLIGATIONS AND LIABILITIES, EXPRESS OR IMPLIED, STATUTORY OR OTHERWISE IN CONNECTION WITH THE PRODUCT, HOWEVER ARISING (WHETHER BY CONTRACT, TORT, NEGLIGENCE, PRINCIPLES OF MANUFACTURER'S LIABILITY, OPERATION OF LAW, CONDUCT, STATEMENT OR OTHERWISE), INCLUDING WITHOUT RESTRICTION ANY IMPLIED WARRANTY OR CONDITION OF QUALITY, MERCHANTABILITY OR FITNESS FOR A PARTICULAR PURPOSE. ANY IMPLIED WARRANTY OF MERCHANTABILITY OR FITNESS FOR A PARTICULAR PURPOSE TO THE EXTENT REQUIRED UNDER APPLICABLE LAW TO APPLY TO THE PRODUCT SHALL BE LIMITED IN DURATION TO THE PERIOD STIPULATED UNDER THIS LIMITED WARRANTY.

IN NO EVENT WILL XANTREX BE LIABLE FOR ANY SPECIAL, INDIRECT, INCIDENTAL OR CONSEQUENTIAL DAMAGES, LOSSES, COSTS OR EXPENSES HOWEVER ARISING WHETHER IN CONTRACT OR TORT INCLUDING WITHOUT RESTRICTION ANY ECONOMIC LOSSES OF ANY KIND, ANY LOSS OR DAMAGE TO PROPERTY, ANY PERSONAL INJURY, ANY DAMAGE OR INJURY ARISING FROM OR AS A RESULT OF MISUSE OR ABUSE, OR THE INCORRECT INSTALLATION, INTEGRATION OR OPERATION OF THE PRODUCT.

## Exclusions

If this product is a consumer product, federal law does not allow an exclusion of implied warranties. To the extent you are entitled to implied warranties under federal law, to the extent permitted by applicable law they are limited to the duration of this Limited Warranty. Some states and provinces do not allow limitations or exclusions on implied warranties or on the duration of an implied warranty or on the limitation or exclusion of incidental or consequential damages, so the above limitation(s) or exclusion(s) may not apply to you. This Limited Warranty gives you specific legal rights. You may have other rights which may vary from state to state or province to province.

## Warning: Limitations On Use

Please refer to your product manual for limitations on uses of the product.

SPECIFICALLY, PLEASE NOTE THAT THE XFR 2800 WATT SERIES PROGRAMMABLE DC POWER SUPPLY SHOULD NOT BE USED IN CONNECTION WITH LIFE SUPPORT SYSTEMS OR OTHER MEDICAL EQUIPMENT OR DEVICES. WITHOUT LIMITING THE GENERALITY OF THE FOREGOING, XANTREX MAKES NO REPRESENTATIONS OR WARRANTIES REGARDING THE USE OF THE XANTREX XFR 2800 WATT SERIES PROGRAMMABLE DC POWER SUPPLY IN CONNECTION WITH LIFE SUPPORT SYSTEMS OR OTHER MEDICAL EQUIPMENT OR DEVICES.

## Return Material Authorization Policy

Before returning a product directly to Xantrex you must obtain a Return Material Authorization (RMA) number and the correct factory "Ship To" address. Products must also be shipped prepaid. Product shipments will be refused and returned at your expense if they are unauthorized, returned without an RMA number clearly marked on the outside of the shipping box, if they are shipped collect, or if they are shipped to the wrong location.

When you contact Xantrex to obtain service, please have your instruction manual ready for reference and be prepared to supply:

- The serial number of your product
- Information about the installation and use of the unit
- Information about the failure and/or reason for the return
- A copy of your dated proof of purchase

Record these details in "Information About Your System" on page WA-4.

## Return Procedure

1. Package the unit safely, preferably using the original box and packing materials. Please ensure that your product is shipped fully insured in the original packaging or equivalent. This warranty will not apply where the product is damaged due to improper packaging.
2. Include the following:
  - The RMA number supplied by Xantrex Technology Inc. clearly marked on the outside of the box.
  - A return address where the unit can be shipped. Post office boxes are not acceptable.
  - A contact telephone number where you can be reached during work hours.
  - A brief description of the problem.
3. Ship the unit prepaid to the address provided by your Xantrex customer service representative.

**If you are returning a product from outside of the USA or Canada** In addition to the above, you **MUST** include return freight funds and are fully responsible for all documents, duties, tariffs, and deposits.

**If you are returning a product to a Xantrex Authorized Service Center (ASC)** A Xantrex return material authorization (RMA) number is not required. However, you must contact the ASC prior to returning the product or presenting the unit to verify any return procedures that may apply to that particular facility.

## Out of Warranty Service

If the warranty period for your XFR 2800 Watt Series Programmable DC Power Supply has expired, if the unit was damaged by misuse or incorrect installation, if other conditions of the warranty have not been met, or if no dated proof of purchase is available, your inverter may be serviced or replaced for a flat fee.

To return your XFR 2800 Watt Series Programmable DC Power Supply for out of warranty service, contact Xantrex Customer Service for a Return Material Authorization (RMA) number and follow the other steps outlined in “Return Procedure” on page WA-4.

Payment options such as credit card or money order will be explained by the Customer Service Representative. In cases where the minimum flat fee does not apply, as with incomplete units or units with excessive damage, an additional fee will be charged. If applicable, you will be contacted by Customer Service once your unit has been received.

## Information About Your System

As soon as you open your XFR 2800 Watt Series Programmable DC Power Supply package, record the following information and be sure to keep your proof of purchase.

- Serial Number (on DC end) \_\_\_\_\_
- Purchased From \_\_\_\_\_



Purchase Date

\_\_\_\_\_





**Xantrex Technology Inc.**

858 450 0085 Tel  
858 678 4482 Fax  
800 733 5427 Toll Free North America  
prg.info@xantrex.com  
www.xantrex.com

TM-F2OP-C1XN-01

PRINTED IN USA