

OPERATING MANUAL
MODEL 3520
SIGNAL GENERATOR

THIS DOCUMENT CONTAINS INFORMATION PROPRIETARY TO WAVETEK. THE INFORMATION IN THIS DOCUMENT IS NOT TO BE USED OR DUPLICATED IN ANY MANNER WITHOUT THE PRIOR APPROVAL IN WRITING OF WAVETEK.

WAVETEK INDIANA, INC.
5808 CHURCHMAN, P.O. BOX 190
BEECH GROVE, IN 46107
317-787-3332
(TOLL FREE OUTSIDE INDIANA)
1-800-428-4424

REV E

WARRANTY

All Wavetek instruments are warranted against defects in material and workmanship for a period of one year after date of manufacture. Wavetek agrees to repair or replace any assembly or component (except batteries) found to be defective under normal use during this period. Transfermatic Switch assemblies, manufactured by Wavetek, are unconditionally warranted for the life of the instrument. Wavetek's obligation under this warranty is limited solely to repairing any such instrument which, in Wavetek's sole opinion, proves to be defective within the scope of the warranty when returned to the factory or to an authorized service center. Transportation to the factory or service center is to be prepaid by purchaser. Shipment should not be made without prior authorization by Wavetek.

This warranty does not apply to any products repaired or altered by persons not authorized by Wavetek, or not in accordance with instructions furnished by Wavetek. If the instrument is defective as a result of misuse, improper repair, or abnormal conditions or operations, repairs will be billed at cost.

Wavetek assumes no responsibility for its product being used in a hazardous or dangerous manner either alone or in conjunction with other equipment. High voltage used in some instruments may be dangerous if misused. Special disclaimers apply to these instruments. Wavetek assumes no liability for secondary charges or consequential damages and, in any event, Wavetek's liability for breach of warranty under any contract or otherwise shall not exceed the purchase price of the specific instrument shipped and against which a claim is made.

Any recommendations made by Wavetek for use of its products are based upon tests believed to be reliable, but Wavetek makes no warranty of the results to be obtained. This warranty is in lieu of all other warranties, expressed or implied, and no representative or person is authorized to represent or assume for Wavetek any liability in connection with the sale of our products other than set forth herein.

CONTENTS

SECTION 1 - GENERAL INFORMATION

- 1.1 INTRODUCTION
- 1.2 SPECIFICATIONS
- 1.3 OPTIONS
- 1.4 ACCESSORIES

SECTION 2 - OPERATION

- 2.1 INTRODUCTION
- 2.2 MECHANICAL INSTALLATION
- 2.3 ELECTRICAL INSTALLATION
- 2.4 DESCRIPTION OF FRONT PANEL
- 2.5 DESCRIPTION OF REAR PANEL
- 2.6 INSTALLATION CHECKS
- 2.7 OPERATING PROCEDURE
- 2.8 GPIB PROGRAMMING

SECTION 3 - THEORY OF OPERATION

- 3.1 INTRODUCTION
- 3.2 DIGITAL CONTROL SECTION OVERVIEW
- 3.3 RF GENERATING SECTION OVERVIEW
- 3.4 PHASE-LOCKED LOOPS
- * 3.5 M9W SWEEP OSCILLATOR
- * 3.6 M10W-15 DRIVER AMPLIFIER
- * 3.7 M30-5 CRYSTAL REFERENCE
- * 3.8 FREQUENCY DOUBLERS
- * 3.9 M35-6/7 REVERSE POWER PROTECTION
- * 3.10 M207 PROGRAMMABLE ATTENUATOR
- * 3.11 POWER SUPPLY

SECTION 4 - PERFORMANCE TESTS

- 4.1 INTRODUCTION
- 4.2 FREQUENCY RANGE AND RESOLUTION TEST
- 4.3 FREQUENCY ACCURACY TEST
- 4.4 FREQUENCY STABILITY TEST
- 4.5 OUTPUT LEVEL ACCURACY TEST
- 4.6 HARMONICS TEST
- 4.7 NON-HARMONIC TEST
- 4.8 RESIDUAL AM TEST
- 4.9 RESIDUAL FM TEST
- 4.10 INTERNAL MODULATION FREQUENCY ACCURACY TEST
- 4.11 PERCENT AM ACCURACY TEST
- 4.12 AM BANDWIDTH TEST
- 4.13 AM DISTORTION TEST
- 4.14 FM DEVIATION ACCURACY TEST
- 4.15 FM BANDWIDTH TEST
- 4.16 FM DISTORTION TEST
- 4.17 IMPEDANCE TEST
- 4.18 RFI TEST
- 4.19 REVERSE POWER PROTECTION CHECK

* These paragraphs are included in SERVICE MANUAL only.

CONTENTS (Continued)

- * SECTION 5 - MAINTENANCE
 - 5.1 INTRODUCTION
 - 5.2 SERVICE INFORMATION
 - 5.3 CALIBRATION PROCEDURE
 - 5.4 TROUBLESHOOTING

- * SECTION 6 - REPLACEABLE PARTS
 - 6.1 INTRODUCTION
 - 6.2 MANUFACTURERS CODE
 - *** PARTS LIST

- * SECTION 7 - SCHEMATICS
 - 7.1 INTRODUCTION
 - 7.2 SCHEMATIC NOTES
 - 7.3 SCHEMATIC INDEX
 - *** SCHEMATICS

- * SECTION 8 - MANUAL CHANGES & OPTIONS
 - 8.1 INTRODUCTION
 - 8.2 MANUAL CHANGES
 - 8.3 OPTIONS

* These sections are included in SERVICE MANUAL only.

Operator Manual Changes and Option descriptions are included at the rear of this manual.

1.1 INTRODUCTION

The Wavetek Model 3520 is a rugged, microprocessor controlled, GPIB-addressable Signal Generator covering the frequency range of 1 to 2080 MHz.

All instrument parameters are set via either front-panel keyboard entry or GPIB (IEEE-488) interface. Instrument settings and parameters are displayed on three alphanumeric vacuum-fluorescent displays.

A flexible cursor system allows a selected digit of a parameter to be incremented, or the parameter may be incremented by a user-defined step size. A relative/reference function may be used to test with respect to a specified parameter value.

Nonvolatile memory locations allow up to 32 complete front panel settings to be quickly stored and recalled in any order.

1.1.1 FREQUENCY CHARACTERISTICS

The carrier frequency may be set to a resolution of 100 Hz from 1 to 1040 MHz, and 200 Hz from 1041 to 1080 MHz. The accuracy of the instrument is based on a crystal-controlled oscillator which serves as a stable frequency reference, enabling the instrument to provide high-stability signals to an accuracy of 0.001% over its specified frequency range. This accuracy includes possible errors due

to short-term drift, long-term drift, incidental FM, and variations due to line voltage changes and temperature changes. The accuracy of the instrument can be improved by using the optional External Reference input, the optional Internal/External Reference, and/or the optional High Stability Internal Reference.

1.1.2 MODULATION

The instrument features both internal and external AM and FM capabilities. The internal modulation source may be set to any 1 Hz multiple between 80 Hz and 999 kHz and 10 Hz multiple between 1 kHz and 10 kHz. FM deviation can be set to any desired value up to 100 kHz. AM depth is specified from 0 to 90%.

The internal and external sources may be used simultaneously to produce complex modulation. An automatic level control (ALC) function is provided to normalize external sources.

1.1.3 OUTPUT LEVEL FEATURES

The 50 ohm calibrated output of the instrument is leveled to ± 2.0 dB across the 1 to 2080 MHz frequency range. RF output level is settable from +10 dBm to -137 dBm with a resolution of 0.1 dB.

The level may be read out in dBm or in Volts RMS. Reverse power protection to 50 watts is standard.

1.2 SPECIFICATIONS

1.2.1 RF FREQUENCY

Range	1 to 2080 MHz
Readout	Alphanumeric vacuum-fluorescent display
Resolution	100 Hz (1-1039.9999 MHz) 200 Hz (1040-2080 MHz)
Accuracy	$\pm 0.001\%$ in all modes with ALC on; $\pm(0.001\% + 10$ kHz) in all modes with ALC off
Stability (after 1 hr warmup)	0 to 520.9999 MHz: 0.2 ppm/hr with ALC on; 500 Hz/10 min with ALC off 521 to 1039.9999 MHz: 0.2 ppm/hr with ALC on; 1000 Hz/10 min with ALC off 1040 to 2080 MHz: 0.2 ppm/hr with ALC on; 2000 Hz/10 min with ALC off
Switching Speed	Typically <275 msec (<115 msec for steps >1 MHz)

1.2.2 RF OUTPUT

Impedance	50 ohms (SWR <1.3 at RF levels below 0.1 VRMS).
Power Level Range	+10 to -137 dBm (1 V to 0.0316 μ VRMS)
Readout	Alphanumeric vacuum-fluorescent display
RF Level Control	Adjustable in 0.1 dB steps in dBm mode, or to three significant digits in voltage mode
Total Level Accuracy	+10 to -36.9 dBm ± 2.0 dB -37 to -46.9 dBm ± 2.2 dB -47 to -56.9 dBm ± 2.4 dB -57 to -66.9 dBm ± 2.6 dB -67 to -76.9 dBm ± 2.8 dB -77 to -86.9 dBm ± 3.0 dB -87 to -96.9 dBm ± 3.2 dB -97 to -106.9 dBm ± 3.4 dB -107 to -116.9 dBm ± 3.6 dB -117 to -126.9 dBm ± 3.8 dB -127 to -137 dBm ± 4.0 dB
Accuracy Traits	Flatness: (+10 to -6.9 dBm) ± 1.5 dB Step Attenuator: ± 0.6 dB or 2% of attenuation, whichever is greater
Leakage	< 1 μ V into a two-turn, 1 inch diameter loop held 1 inch from any surface at 500 MHz.
Output Connector	Type N

1.2.3 SPECTRAL PURITY

Harmonic Output

1 to 10 MHz	<-26 dBc
10 to 1040 MHz	<-30 dBc
1041 to 2080 MHz	<-25 dBc

Nonharmonics

Fundamental	Spurious Level
1 to 3 MHz	<-60 dBc in 1 to 3 MHz band
3.0001 to 250 MHz	<-65 dBc in 3 to 250 MHz band
3.0001 to 350 MHz	<-55 dBc in 3 to 350 MHz band
3.0001 to 520 MHz	<-35 dBc in 3 to 1000 MHz band
3.0001 to 2000 MHz	<-30 dBc in 3 to 4160 MHz band
3.0001 to 2080 MHz	<-25 dBc in 3 to 4160 MHz band

Subharmonics

1 to 520.9999 MHz: none detectable
521 to 2080 MHz: <-30 dBc

Residual FM

1 to 520.9999 MHz: <200 Hz in a 50 Hz to 15 kHz post-detection bandwidth (typically <100 Hz)
521 to 1040.9999 MHz: <400 Hz in a 50 Hz to 15 kHz post-detection bandwidth (typically <200 Hz)
1041 to 2080 MHz: <800 Hz in a 50 Hz to 15 kHz post-detection bandwidth (typically <400 Hz)

Residual AM

<-60 dBc in a 50 Hz to 15 kHz post-detection bandwidth.

Phase Noise

1 to 520.9999 MHz: <-93 dBc typical (offset 20 kHz from carrier with 1 Hz bandwidth)
1 to 520.9999 MHz: <-120 dBc typical (offset 500 kHz from carrier with 1 Hz bandwidth)
521 to 1040.9999 MHz: <-87 dBc typical (offset 20 kHz from carrier with 1 Hz bandwidth)
521 to 1040.9999 MHz: <-114 dBc typical (offset 500 kHz from carrier with 1 Hz bandwidth)
1041 to 2080 MHz: <-81 dBc typical (offset 20 kHz from carrier with 1 Hz bandwidth)
1041 to 2080 MHz: <-108 dBc typical (offset 500 kHz from carrier with 1 Hz bandwidth)

1.2.4 AMPLITUDE MODULATION

NOTE: These specifications apply for a carrier level $\leq +2$ dBm. AM is possible above +2 dBm if the peak output does not exceed +10 dBm.

Internal Frequency Source

80 Hz to 999 kHz in 1 Hz steps
1 kHz to 10 kHz in 10 Hz steps

Internal Frequency Accuracy

$\pm(2\% + 6 \text{ Hz})$ of Reading

External Frequency Input	DC to 30 kHz (3 dB bandwidth) with ALC off. 100 Hz to 30 kHz (3 dB bandwidth) with ALC on. Input level required for calibrated display: 10 Vp-p into 600 ohms with ALC off; 0.25 to 1 Vp-p into 600 ohms with ALC on.
Depth Resolution	0.1%
Depth Indicator Accuracy	0 to 90%: $\pm 6\%$ of reading
Readout	Alphanumeric vacuum-fluorescent display
Range	0 to 100%
Distortion (measured at 1 kHz)	0 to 30% AM: $<1.5\%$ 0 to 70% AM: $<3\%$ 0 to 90% AM: $<5\%$

1.2.5 FREQUENCY MODULATION

Internal Frequency Source	80 Hz to 999 kHz in 1 Hz steps 1 kHz to 10 kHz in 10 Hz steps
Internal Frequency Accuracy	$\pm(2\% + 6 \text{ Hz})$ of Reading
External Frequency Input	DC to 60 kHz (1 dB bandwidth) with ALC off. 100 Hz to 60 kHz (1 dB bandwidth) with ALC on. Input level required for calibrated display: 10 Vp-p into 600 ohms with ALC off; 0.25 to 1 Vp-p into 600 ohms with ALC on.
Deviation Resolution	100 Hz for deviations <10 kHz 1 kHz for deviations ≥ 10 kHz
Deviation Indicator Accuracy	$\pm 5\%$ of reading
Readout	Alphanumeric vacuum-fluorescent display
Range	0 to 100 kHz deviation
Distortion (measured at 1 kHz)	10 to 100 kHz deviation: $<2\%$ 3 to 10 kHz deviation: $<4\%$

1.2.6 REVERSE POWER PROTECTION

Trip Time	<2 msec
RF Trip Level	approximately 0.7 W
Maximum RF Input	50 W
DC Blocking Voltage	50 Volts

1.2.7 REMOTE PROGRAMMING

Interface GPIB; Conforms to IEEE Standard 488-1978. Controls all functions.

Function Listens and talks, gives error status and instrument status. SH1, AH1, T6, TEO, L4, LEO, SR1, RL1, PPO, DC1, DT1, CO, E2.

1.2.8 GENERAL

Dimensions 43.2 cm (17 in) wide; 14.6 cm (5-3/4 in) high; 40.6 cm (16 in) deep

Weight 14.5 kg (32 lb)

Power 90 to 110, 110 to 130, 180 to 220, or 220 to 240 VAC; 50 to 400 Hz: approximately 75 watts.

Operating Temperature 25 \pm 5° C, all specifications apply; 25 \pm 15° C, with slight degradation of specifications

1.3 OPTIONS

1.3.1 OPTION 5 External Reference. Provides a rear-panel BNC connector for an external frequency reference. Reference frequency can be 1, 2, 2.5, 5, or 10 MHz, with minimum level of 50 mV into 1 k Ω .

1.3.2 OPTION 5A Internal/External Reference. Uses either an internal TCXO or an external source as the instrument frequency reference. Internal TCXO improves accuracy to 1 ppm from the standard 10 ppm, and can be used as a reference for other devices. External reference may be 5 or 10 MHz, 0.5 to 5 VRMS.

1.3.3 OPTION 8 1 kHz Low End. Extends the low frequency capability to 1 kHz.

1.3.4 OPTION 9 Rear Panel RF & Modulation connectors.

1.4 ACCESSORIES

Furnished with instrument Operating manual.

Available at extra cost
Rack Mount Kit (K0234)
Precision Frequency Standard (5 MHz), Model 2102
GPIB cable (1 meter) PN 6000-50-0006
GPIB cable (2 meter) PN 6000-50-0007
Module Service Kit (K0244)
Service Manual

2.1 INTRODUCTION

This section provides complete installation and operating instructions for the Wavetek Model 3520. The instructions include information on mechanical installation, electrical installation, front- and rear-panel features, installation checks, and operating procedures.

2.2 MECHANICAL INSTALLATION

2.2.1 INITIAL INSPECTION

After unpacking the instrument, visually inspect external parts for damage to connectors, surface areas, etc. The shipping container and packing material should be saved in case it is necessary to reship the unit.

2.2.2 DAMAGE CLAIMS

If the instrument received has been damaged in transit, notify the carrier and either the nearest Wavetek area representative or the factory in Indiana. Retain the shipping carton and packing material for the carrier's inspection. The local representative or the factory will immediately arrange for either replacement or repair of your instrument without waiting for damage claim settlements.

2.2.3 RACK MOUNTING (Kit K0234)

See Figure 2-1 for assembly drawing.

ITEM	QTY	PART NO.
A (Side)	2	1019-00-0234
B (Screw)	2	2810-17-6106
C (Screw)	2	2810-17-6110

PROCEDURE

Remove the four screws securing one side panel to the instrument. Place one rack mount side (Item A) over the side panel and secure with the screws (Items B & C) provided in the rack mount kit. Repeat for the other side of the instrument.

CAUTION

If the rack mount kit is removed from the instrument, use the screws originally installed in the side panels to avoid possible internal damage.

2.3 ELECTRICAL INSTALLATION

The instrument can operate from 100, 110, 220, or 240 VAC supply mains. The rear-panel AC LINE connector selects which of these operating voltages is being used, and adjusts the Power Supplies accordingly. (Refer to Figure 2-4.) The Power Supplies are designed to operate over an AC supply frequency range of 50 to 400 Hz.

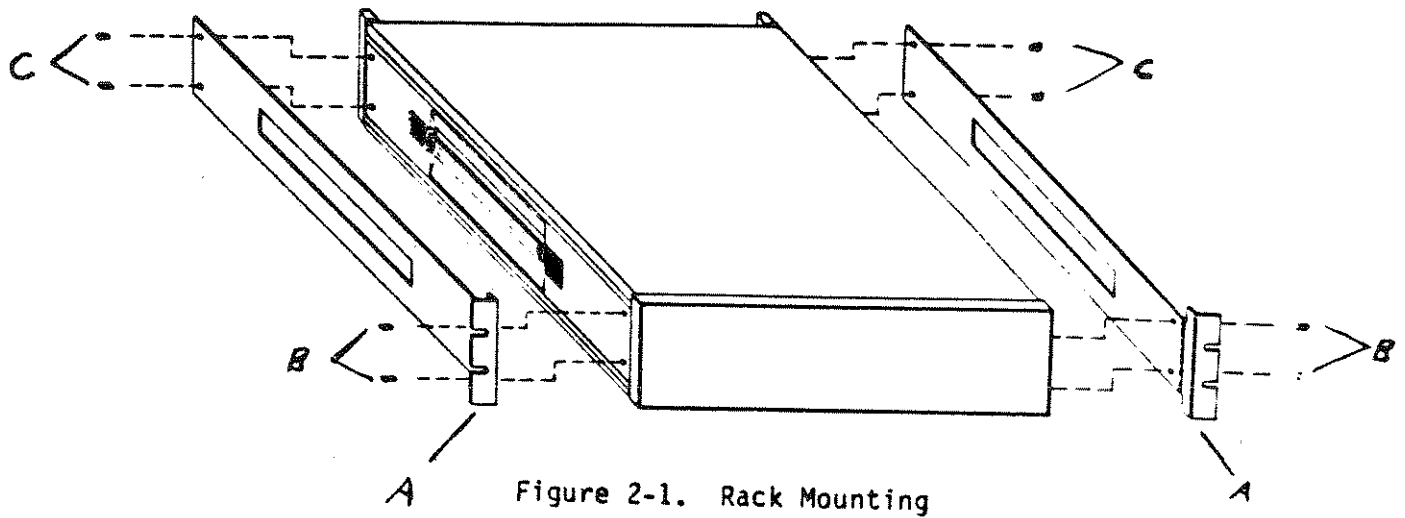

Figure 2-1. Rack Mounting

NOT AVAILABLE

Figure 2-2. Front Panel

NOT AVAILABLE

Figure 2-3. Rear Panel

Instruments are shipped from the factory set up for 110 VAC operation unless otherwise specified.

NOTE

Before operating the instrument, check that the rear-panel AC LINE fuse is the correct value for the supply voltage (see Section 2.5).

2.4 DESCRIPTION OF FRONT PANEL

Refer to Figure 2-2.

2.4.1 CONNECTORS/SWITCHES

(1) RF OUT connector provides connection for RF output signal.

(2) EXT MOD IN connector provides input for external AM or FM signal.

(3) POWER switch applies AC voltage to the Power Supplies.

2.4.2 KEYBOARD

The front-panel KEYBOARD is divided into several functional group areas. The following descriptions are referenced to each functional group.

NOTE

For each function which can be addressed via the GPIB, the function code letter is printed in white at the lower left of the function key.

(4) GPIB

ADRS key enables the user to display and reset the instrument My Listen Address (MLA).

CMD/RCL key displays the 40 most recent command/data characters on the MODULATION/GPIB display. (only 20 characters are displayed at a time. Pressing the → or ← CURSOR key shifts the display 5 characters.)

LCL key returns control of the instrument to the front-panel KEYBOARD unless the GPIB Local Lockout is enabled.

SRQ key sends a service request over the GPIB to the controller.

(5) MODULATION

AM key selects amplitude modulation and enables the data keys to enter the % modulation.

FM key selects frequency modulation and enables the data keys to enter the FM deviation.

PM key has no function unless pulse modulation option is installed.

EXT key selects the EXT MOD IN connector as the modulating signal source.

CW key selects no modulation (continuous wave output).

RATE key enables the data keys to enter the internal modulation frequency.

STAT key sequentially displays the active parameter values.

ALC key selects whether the automatic level control (ALC) circuitry is active (ALC 1) or inactive (ALC 0).

(6) MAIN

FREQ key enables the data keys to select the CW or carrier frequency.

LEV key enables the data keys to select the RF output level.

(7) SETTING

STOR key enables the present instrument parameters to be stored (in an address selected via the data keys) for future recall.

RCL key enables a previously stored setting to be recalled when addressed via the data keys.

(8) REF

SET key enables an output frequency or output level to be used as a reference, with the REL key used to vary the active parameter about the reference.

REL key enables the data entered via the data keys to be referenced (+/-) relative to the reference value selected via the SET key.

(9) CURSOR

The CURSOR keys allow the active output parameter digits to be incremented by units of 1 or the whole parameter to be incremented by a user defined step size. The up and down cursor keys may also be used to sequence the stored settings.

(10) OUT

ON key selects whether the RF output is enabled (ON 1) or disabled (ON 0).

RST key resets the reverse power protection circuit when it has been tripped. The RST key can also be used as a "push-to-test" button to check the operation of the reverse power protection circuit (see Section 4.19).

(11) DATA

The 10 number keys, the decimal key, and the +/- key allow the entry of the numeric portion of output frequency, output level, and modulation data.

The MHz/SEC/V, kHz/mSEC, Hz/ μ SEC/ μ V, and %/dBm keys (units keys) select the units of the data being entered and executes the data entry.

EXP key selects the exponent (power of 10) of the data being entered.

CLR key allows the clearing of the data being entered, and restores the applicable display to the current output parameter.

EXEC key executes the data entry.

TONE key enables or disables (toggles) the internal audio indicator.

(12) OTHER

UNIT RST key resets the instrument to its turn-on parameters.

DISP TEST key turns on all display segments for approximately one second as a check for defective or burned-out segments.

STEP SIZE allows the data keys to enter the increment of change implemented by the CURSOR keys.

2.4.3 DISPLAYS

The instrument parameters are shown on three alpha-numeric, vacuum-fluorescent displays.

(13) MODULATION/GPIB display shows the modulation parameter most recently selected (deviation, depth, rate), or the GPIB data.

(14) FREQUENCY display shows the current output CW or carrier frequency in MHz. If one of the phase-locked loops in the instrument has become unlocked, the display will read "XXX UNLOCKED", where XXX indicates the module controlling the phase-locked loop.

(15) LEVEL display shows the current output level in dBm, or VRMS as selected. If the leveling circuits in the instrument cannot maintain proper leveling, the display will read "XXX UNLEVELED", where XXX indicates the module containing the unleveled circuit. The display will also show the status of the RF Circuit Breaker circuit and the RF output on/off status.

2.5 DESCRIPTION OF REAR PANEL

Refer to Figure 2-3.

(1) AC LINE connector provides connection to AC mains via line cord with 3-prong plug. Also contained in this connection are the line fuse (time delay; 3 A for 100/120 VAC operation, 1.5 A for 220/240 VAC operation), and the voltage selector card for selecting the applicable AC supply voltage (see Figure 2-4).

(2) GPIB connector allows instrument operation from a remote controller (refer to Section 2.8).

(3) OPTION holes accommodate options installed in the instrument.

The rear panel option holes are assigned as follows:

- 1 Option 05/05A
- 2 Option 06
- 3-6 Future Use

(4) The fan removes heat from the instrument, and lowers its operating temperature.

(5) Intake air vent.

2.6 INSTALLATION CHECKS

The following procedure is used to determine that the instrument is operating properly. Performance testing and calibration procedures for the instrument are contained in other sections of this manual. If it is determined that the unit is not operating properly, refer to these sections.

2.6.1 TURN ON

Verify that the power-transformer primary is matched to the available line voltage, and that the proper fuse is installed (see Section 2.5). Depress the POWER switch. The displays will indicate operation. The instrument turn-on parameters are as follows:

OUTPUT FREQUENCY	260 MHz
OUTPUT LEVEL	0 dBm (RF off)
MODULATION	CW

When the instrument is initially powered up, an RF off symbol will appear to the right of the level display indicating the RF output is shut off (see Table 2-1). In order to turn it on, press the OUT-ON key, enter a 1 and execute (EXEC) the entry.

No warmup is needed for the following checks; however a high-frequency oscilloscope must be used.

2.6.2 RF OUTPUT CHECK

Connect the equipment as shown in Figure 2-5 and call stored setting 601 (refer to Section 2.7.8). The 10 MHz signal should be approximately 1 Vpp.

2.6.3 AM CHECK

Call stored setting 602. Verify that the AM envelope displayed on the oscilloscope has a peak-to-valley voltage of approximately 0.5 V and a period of 1 msec (see Figure 2-6).

2.6.4 FM CHECK

Call stored setting 603 and set an FM deviation of 100 kHz by pressing FM 100 kHz. Verify that an FM display appears on the oscilloscope (see Figure 2-7).

2.6.5 ATTENUATION CHECK

Call stored setting 438. Verify that the 1 MHz CW signal is approximately 0.2 Vpp.

2.7 OPERATING PROCEDURE

No preparation for operation is required beyond completion of the initial installation checks contained in Section 2.6. To insure that the instrument will perform as stated in the specifications, the instrument should have a two-hour warmup before using. If the instrument is not going to be used to the extreme limits of its specifications, it can be used immediately.

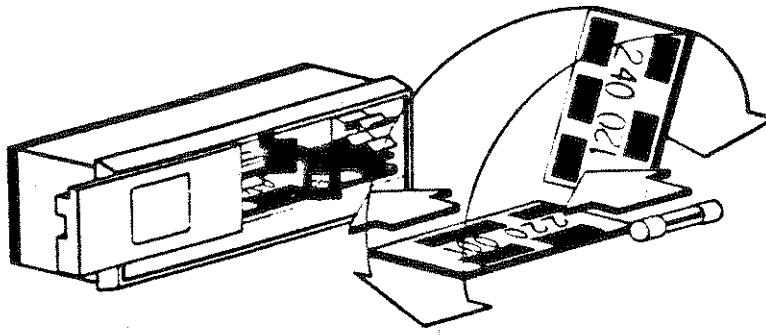

Remove the line cord and slide the window all the way to the left. Remove the fuse by pulling the lever. Remove the voltage-selector card. Orient the voltage-selector card so that the desired voltage is in the upper left and push the card firmly into the slot. Swing the lever to the right and check that the selected voltage is visible. Replace the fuse, slide the window to the right, and replace the line cord.

NOTE

Check that the fuse is the proper value for the selected voltage (see Section 2.5).

Figure 2-4. Voltage Selection

NOTE: MUST BE HIGH-FREQUENCY OSCILLOSCOPE (GREATER THAN 10 MHz)

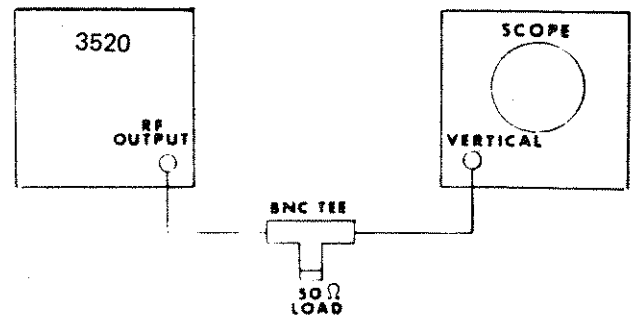

Figure 2-5. Test Setup

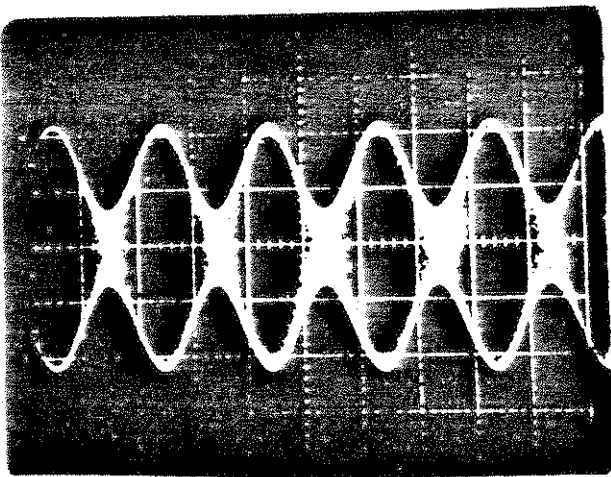

Figure 2-6. Amplitude Modulation

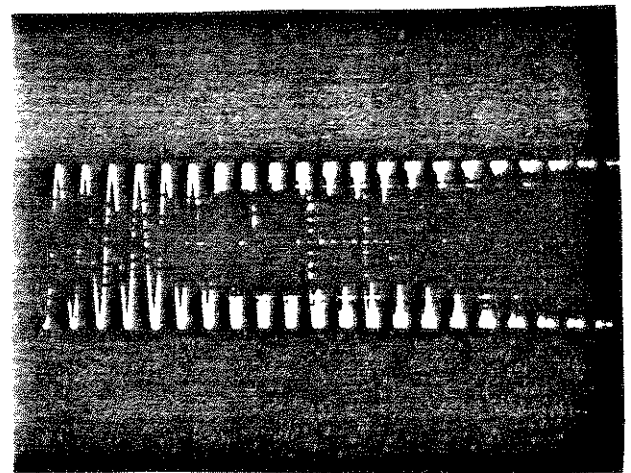

Figure 2-7. Frequency Modulation









SYMBOL	MEANING
	Non-executed Scratch Setting
	Reference Setting
	Relative Readout
	Step Size
	RF Output Turned Off
	ALC Turned Off
	Unterminated Entry
	Remote Operation
	Display Test

Table 2-1. Special Mode Indicators

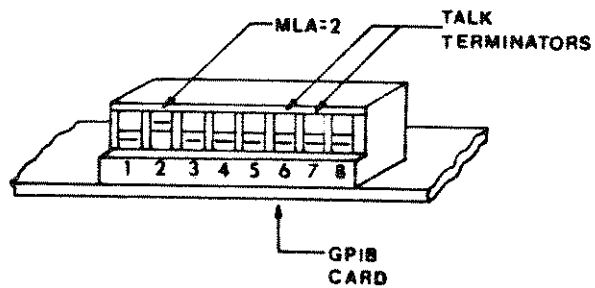

Figure 2-8. Switch S1 (Factory Settings)

CAUTION

Check the air flow regularly from the rear-panel fan. When air flow is reduced, clean the filters installed in the intake vents.

2.7.1 TURN ON

Depress the POWER switch. The turn-on parameters are as listed in Section 2.6.1.

2.7.2 DATA ENTRY (GENERAL)

The instrument parameter values may be entered in one of two formats; string entry and units entry. In each format there must be a header (parameter function), the data, and a terminator.

In units entry, a header, the data, and a terminator are selected on the KEYBOARD. When the terminator (units key) is selected, the data is transferred into the microprocessor memory and is executed. One function at a time may be implemented using units entry. Exponential data values may be used, but are more commonly not helpful.

NOTE

An audible tone or "beep" is emitted with each keyboard entry. An invalid entry causes a double beep. See 2.7.14.

In string entry, a header and the data are selected as in units entry; however, instead of a units key being pressed as a terminator for each function, a series of functions may be entered in a string, with the terminator (a units key or the EXEC key) being pressed at the end of the string to execute the entire series simultaneously. The units are assumed to be the lowest possible for each parameter (except for level entries, which will retain the units of the last previous entry), thus exponential values are commonly used.

For example, to enter an output frequency of 125.4730 MHz, an output level of -4.5 dBm, and a modulation setting of 40 kHz FM deviation at a 1.2 kHz rate, the keystrokes required would be:

UNITS ENTRY	STRING ENTRY
MAIN FREQ	MAIN FREQ
1	1
2	2
5	5
.	.
4	4
7	7
3	3
MHZ	EXP
MAIN LEV	6
+/-	MAIN LEV
4	+/-
.	4
5	.
%/DBM	5
MOD FM	MOD FM
4	4
0	EXP
KHZ	4
MOD RATE	MOD RATE
1	1
.	.
2	2
KHZ	EXP
	3
	EXEC

In string entry, the header for the next function entry serves as the terminator for the current function entry, and causes it to be transferred into a "scratchpad" memory. It is therefore important to terminate the last entry in a string after which no header would normally follow. This terminator may be any function header. The entire string is then retained in the scratchpad until the final terminator (units or EXEC key) is pressed, at which time all values in the scratchpad are transferred into the microprocessor memory and executed.

The CLR key deletes the data being entered from the scratchpad and display register, and replaces it with the executed parameter values.

The MODULATION STAT key causes the executed values for each instrument parameter to be displayed, with the modulation parameters being displayed sequentially with each press of the MODULATION STAT key. The scratchpad memory values are not affected.

2.7.3 FREQUENCY SELECTION

To select the output CW or carrier frequency, press the MAIN FREQ key and enter the desired frequency on the data keys (be sure to press the correct units key or the EXEC key). The FREQUENCY display will show the data as it is being entered. When the units or EXEC key is pressed, the display will change to show the selected frequency in MHz. If the frequency selected is invalid, a double tone will sound (if the tone is enabled), and the display will revert to the previous reading to show that the new entry has not been accepted.

2.7.4 LEVEL SELECTION

To select the output level, press the MAIN LEV key, and enter the desired level on the data keys (be sure to press the correct units key or the EXEC key). The output level may be entered in dBm, VRMS, mVRMS, or μ VRMS. If the EXEC key is pressed, the units from the previous entry will be retained. The LEVEL display will show the data as it is being entered. When the units or EXEC key is pressed, the display will change to show the selected level in the units selected (if the EXEC key was pressed, the units displayed will be the same as for the previous level setting). If the level selected is invalid, a double tone will sound (if the tone is enabled) and the display will revert to the previous reading to show that the new entry has not been accepted.

2.7.5 INT AM/FM OPERATION

To modulate the carrier frequency or output level with the internal source, press the MODULATION AM or FM key, as desired, and enter the desired modulation depth (%) or deviation (Hz or kHz) via the data keys (be sure to press the correct units key or the EXEC key). Press the MODULATION RATE key and enter the desired modulating frequency via the data keys. The MODULATION display will show the data as it is being entered. When the units or EXEC key is pressed, the display will change to show the selected modulation parameter in the units selected (if the EXEC key was pressed, the units displayed will be the same as for the previous setting). If the modulation parameter selected is invalid, a double tone will sound (if the tone is enabled), and the display will revert to the previous reading to show that the new entry has not been accepted. To turn off the modulation, press MODULATION CW and EXEC.

2.7.6 EXT AM/FM OPERATION

To modulate the carrier frequency or output level with an external source, press the MODULATION EXT and AM or FM keys, as desired, and connect the modulating signal. For a calibrated display, the external signal level should be between 0.1 and 1 Vp-p with ALC enabled, or 10 Vp-p with ALC disabled. Enter the desired modulation depth (%) or deviation (Hz or kHz) via the data keys (be sure to press the correct units key or the EXEC key).

The MODULATION display will show the data as it is being entered. When the units or EXEC key is pressed, the display will change to show the selected modulation parameter in the units selected (if the EXEC key was pressed, the units displayed will be the same as for the previous setting). If the modulation parameter selected is invalid, a double tone will sound (if the tone is enabled), and the

display will revert to the previous reading to show that the new entry has not been accepted.

CAUTION

Input voltage greater than ± 5 VDC or 3.5 VRMS should not be applied to the EXT MOD IN connector, or damage to the instrument may occur.

NOTE

When amplitude modulating, care must be taken to not exceed the +13 dBm maximum level, or excessive distortion and an unlevelled condition can exist.

To turn off the modulation, press MODULATION EXT, CW and EXEC.

2.7.7 SIMULTANEOUS INT/EXT AM/FM OPERATION

Internal and external modulation can be performed simultaneously by following the procedures given in sections 2.7.5 and 2.7.6 with both internal and external modulating sources active. In this way, FM/FM, FM/AM, or AM/AM can be accomplished.

2.7.8 STORED SETTINGS

The instrument memory contains many standard settings for test and maintenance functions. These are listed in Table 4-2. To call one of these settings, press the SETTING RCL key, the stored setting location number, and the EXEC key.

Other settings may be programmed and stored by the user in a non-volatile memory. This memory holds 32 complete front panel settings in locations, addresses numbered 01 through 32. Each of these locations are partitioned into three independently addressable subgroups.

A prefix numbered 0 - 3 precedes the location address to identify the subgroups or groups that are to be specifically addressed.

The information contained in each subgroup is as shown in Table 2-2. This table may be copied and used to record user defined settings.

A 0 prefix is used to address the entire contents of a location.

A 1 prefix addresses modulation parameters. These include the modulation status of the two individual internal and external modulation sources, an internal modulation rate, and the AM% and FM deviation parameters for the internal and external modes.

A 2 prefix addresses the MAIN frequency parameter.

A 3 prefix addresses the RF amplitude parameter and the RF on/off status. The use of a prefix before the location address allows all three subgroups or individual subgroups to be addressed and manipulated. To recall the frequency parameter stored in location 09, for example, the keystroke sequence would be:

RCL 209 EXEC

NOTE

When storing or calling a setting, be sure to enter the entire 3-digit location. If only 1 or 2 digits are entered, the instrument will supply following 0s to fill out the location; thus, pressing the SETTING RCL, 2, 3, and EXEC keys would call stored setting 230, not 023.

The ↓ and ↑ CURSOR keys may also be used to increment or decrement the last two digits of the stored setting being called. (E.g., if stored setting 223 were the last function called, pressing the ↑ CURSOR key will call stored setting 224, thus changing the frequency setting to the value stored in user-programmable location 24). If the location called contains an invalid entry, an error message will be displayed. Invalid data does not

NON-VOLATILE MEMORY

0-All										Address
1-Modulation						2-Frequency	3-Level			
Internal			External				AMPLITUDE	RF STATUS (On/Off)		
STATUS	AM%	FM DEV	RATE	STATUS	AM%					
										02
										03
										04
										05
										06
										07
										08
										09
										10
										11
										12
										13
										14
										15
										16
										17
										18
										19
										20
										21
										22
										23
										24
										25
										26
										27
										28
										29
										30
										31
										32

Table 2-2

normally exist in memory locations because they are all filled with valid settings at the factory.

If the memory back-up battery or the RAM on the Multi-function card has been removed during servicing however, these settings will be lost and random data will take their place until the locations are re-programmed.

2.7.9 CURSOR/STEP SIZE OPERATION

The Model 3520 has two systems available for incrementing parameters:

1. increment by cursor position
2. increment by user-defined step size.

The parameters which can be incremented are: output frequency; output level; %AM; FM deviation; and modulation rate.

INCREMENT BY CURSOR POSITION MODE

Press the function key of the parameter you wish to increment and then use the cursor left (←) or the cursor right (→) keys to position the flashing cursor on the digit of the parameter you want to increment. The cursor up (↑) or cursor down (↓) keys may now be used to increment or decrement the active digit by steps of 1. To turn off the increment by position cursor mode, step the cursor off the display so no digits are flashing.

INCREMENT BY STEP SIZE MODE

When the increment by cursor position mode is off (no flashing cursor on the display), the increment by step size mode is enabled. A different step size value may be defined for each parameter. To define the step size, press the STEP SIZE key followed by the parameter key you want to set a step for. Then enter the step size using the entry keys and a units key.

A small z will appear after the entry to indicate it is a step size. The cursor up (↑) and down (↓) keys may then be used to increment and decrement the addressed parameter by the defined step size. The cursor left (←) and right (→) keys serve no purpose in the increment by step size mode; however, pressing either of these keys will cause the flashing cursor to appear on display and therefore revert back to the increment by cursor position mode.

If an attempt is made to use the increment by step size mode when no step size has been defined, the display will default back to the increment by cursor position mode.

NOTE

If the selected parameter range is exceeded using the STEP SIZE or CURSOR keys, a double tone will sound (if the tone is enabled), but no error message will be displayed. The selected parameter and display will remain at the last valid value.

The ↑ and ↓ CURSOR keys may also be used to increment or decrement the called stored setting (refer to Section 2.7.8). The ← and → CURSOR keys may also be used to shift the MODULATION/GPIB display when the GPIB CMD/RCL key has been pressed. The CMD RCL key enables the last 39 command characters to be displayed on the MODULATION/GPIB display, but only 20 may be displayed at one time. Pressing the ← or → CURSOR key allows the display to be shifted by 5 characters. The Step Size and CURSOR functions are not addressable via the GPIB.

2.7.10 RELATIVE REFERENCE OPERATION

This function allows the user to define a set reference frequency and/or level and then program offsets from that set reference. When in this mode the corresponding display reads out the difference between the set reference and the actual settings.

To establish the reference parameter press the REF SET key followed by the parameter function (Main FREQ or main LVL) as desired. Then enter the value via the data keys and terminate it with a units key. When the units key is pressed, the parameter will become the present setting and the display will therefore go to zero (indicating 0 difference between the actual setting and the reference). A small "r" will appear on the display to indicate the readout is relative.

Offsets relative to the set reference may then be entered and displayed by pressing the REF REL key and entering the desired offset via the data keys and units keys. The display will continue to show only the relative difference. The cursor keys may also be used in this mode.

To exit a function from the reference mode press the function key for that parameter and the display will show the actual setting again. To review a set reference value press the REF SET key followed by the function key (main FREQ or main LVL) as desired. The corresponding display will show the set reference value followed by a small "s" to indicate it is a set reference and therefore not necessarily the actual setting.

NOTE

If the selected parameter range is exceeded using this function, a double tone will sound (if the tone is enabled), but no error message will be displayed. The selected parameter and display will remain at the last valid value.

This function is not addressable via the GPIB.

2.7.11 RF ON/OFF OPERATION

The RF output may be disabled while retaining the instrument parameter settings by pressing the OUT ON, 0,

and EXEC keys. The LEVEL display will read "RF OFF (0)". The RF output may be re-enabled by pressing the OUT ON, 1, and EXEC keys. The LEVEL display will read "RF ON (1)". Whenever the RF output is disabled, an RF symbol will appear at the right side of the LEVEL display (see Table 2-1). (This function may also be addressed via the GPIB.)

2.7.12 RF CIRCUIT BREAKER

When a signal of approximately 6 VRMS or more is applied to the RF OUT connector, the RF Circuit Breaker circuit will open the RF output path to protect the instrument from damage. When the RF Circuit Breaker opens, the RF output is interrupted, and the LEVEL display reads "CB TRIPPED".

After the signal is removed from the RF OUT connector, the RF Circuit Breaker circuit may be reset by pressing the OUT RST key (the display will read "CB OPEN (0)"), the 1 key (the display will read "CB CLSD (1)_"), and the EXEC key. The RF Circuit Breaker will close, the display will read "CB CLSD (1)", and the instrument will return to its pre-tripped status.

WARNING

To prevent damage to the RF output stage, never reset a tripped circuit breaker until the reason for the trip has been identified and removed.

2.7.13 ALC

The automatic level control (ALC) circuit serves to provide a calibrated MODULATION display when using an external modulation source with an input level of 0.1 to 1 Vpp. If a calibrated display is not desired, or if modulating frequencies <100 Hz are to be used, the ALC circuit may be disabled by pressing the MODULATION ALC, 0, and EXEC keys. The ALC circuit may be re-enabled by pressing the MODULATION ALC, 1, and EXEC keys. Whenever

the ALC circuit is disabled, an "ALC" symbol will appear on the MODULATION/GPIB display (see Table 2-1). This function may also be addressed via the GPIB.

2.7.14 TONE

The internal audio indicator sounds a tone upon instrument turn-on, at every KEYBOARD key press, and a double tone when an invalid data entry is not accepted. The audio indicator may be disabled after instrument turn-on by pressing the TONE key once. Pressing the TONE key again will re-enable the audio indicator. (The tone function is not addressable via the GPIB.)

2.8 GPIB PROGRAMMING

2.8.1 INTRODUCTION

All instrument functions except Power On/Off may be set via the General Purpose Interface Bus (GPIB). The bus follows the IEEE-488 1978 standard. Bus functions implemented include source handshake, acceptor handshake, talker, listener, service request, remote local, device clear and device trigger. The interface lines are driven by tristate devices.

2.8.2 ADDRESS SETTING

When power is applied to the instrument, or when the instrument is reset to its turn-on parameters, the MLA (My Listen Address) is determined by the setting of positions 1 through 5 of DIP switch S1 on the GPIB card (item 16 on Figure 5-4). The switches are preset at the factory for an address of 2. The MLA can be changed as desired by resetting these switch positions. To gain access to the DIP switch, remove the instrument's top cover (paragraph 5.2). Also see Figure 2-8.

The MLA can also be reset from the front panel by pressing the ADRS key (the current MLA will be displayed),

the desired address number keys (0 to 31), and the EXEC key. The new address will be maintained until it is changed from the front panel or the instrument is reset to its turn-on parameters via the UNIT RST Key, a Reset command, or by removing and re-applying AC power.

2.8.3 LOCAL/REMOTE

When power is first applied to the instrument, or when the instrument is reset to its turn-on parameters, the instrument is in local mode, i.e., all functions are controlled from the front panel. To switch to remote mode, the GPIB controller must send the Remote command to the instrument. When the instrument is in remote mode, the front-panel KEYBOARD is inactive except for the LCL and SRQ keys. (If the Service Request function has not been enabled by the controller, the SRQ key is inactive. If the Local Lockout bus command has been sent by the controller, both the SRQ and LCL keys are inactive.) UNIT RST is also active in remote.

To switch to local mode from remote mode, press the LCL key (unless the Local Lockout command has been sent), send a Q command character or a Go To Local command from the controller, or remove and re-apply AC power.

2.8.4 DATA ENTRY

Data entry (setting parameter values) is accomplished over the GPIB in essentially the same manner as from the front panel (refer to Section 2.7.3). The format of a header, the data, and a terminator must be followed. String entry is the more common method of entry. The headers are as follows:

A	Output Level
B	External modulation
C	AM
D	FM
F	Output frequency
M	Store setting into location

O CW
P RF output on/off
Q Local enable
R RF Circuit Breaker on/off
T Modulation rate
V ALC on/off
Y Call stored setting
Z Unit reset

Following the header is the data itself, which consists of digits 0 through 9, ., -, and E (exponent of 10). For stored settings and the P, R, and V parameters, see Section 2.7.

Following the data is the terminator, which may vary with the header and format. Valid terminators include:

; Optional between data and following header - no function
% Units for AM depth entries
MZ Units terminators for frequency entries, MHz, kHz, and Hz
KZ
HZ
DB Units terminators for level entries, dBm, VRMS, mVRMS, μVRMS
VO
MV
UV
I Execute

For example, to set the parameter values of Section 2.7.2 over the GPIB, the character string would be:

F125.473E6A-4.5D40E3T1.2E3I

The data following the P, R, and V headers will be simply a 1 (enable function) or 0 (disable function). The data following the M and Y headers will be the 3 digit stored setting location (refer to Section 2.7.8).

The Z header (unit reset) causes any characters following the header to be lost until the reset is complete; thus, it is recommended that Z should be sent by itself. The Q header will switch control of the instrument to the front panel, and so any commands or data following the Q header will also be lost.

2.8.5 X COMMANDS

The X commands enable the controller to alter or determine various instrument GPIB functions as desired. These include:

XG Group execute trigger (GET)
XP Parameter value
XQ Service request (SRQ)
XT Talk code
XV Talk terminator

The X commands are self-executing, and thus do not require a following I (execute) command.

2.8.5.1 GET (XG)

The GET (Group Execute Trigger) command may be used to execute previously called commands. The GET function is disabled until enabled by an XG command from the controller, as follows:

XG0 Disable GET function
XG1 Execute (I)
XG2 Call next stored setting

The selected function is executed by sending the GET command from the controller.

2.8.5.2 PARAMETER VALUES (XP)

The value of a currently set parameter (actual value from microprocessor memory) may be requested by the controller using an XP command, as follows:

XPA Output Level
XPBC External AM
XPBD External FM
XPC AM
XPD FM
XPF Output frequency
XPT Modulation rate

When the controller performs a read, an ASCII character string which corresponds to the current value of the parameter will be returned to the controller.

2.8.5.3 SRQ (XQ)

The SRQ (Service Request) function is used to signal the controller that an exception or error condition exists. It is enabled by sending the XQ1 command from the controller, and disabled by sending the XQ0 command.

When an exception or error condition exists with SRQ enabled, the instrument will send an SRQ to the controller. The controller should then perform a serial poll on each device connected to the GPIB to determine which device is requesting service. A byte will be read on the serial poll, with the device requesting service setting bit 7 (right-hand bit = bit 1) of this byte to 1 (thus the byte will be ≥ 40 hexadecimal or ≥ 64 decimal), and all other devices setting bit 7 to 0. If the Model 3520 is requesting service this byte will vary according to the type of exception or error condition, as follows:

	hexadecimal	decimal
Command Error (illegal command, syntax error)	66	102
Execution Error (out of range value, return to local mode)	62	98
Internal Error (hardware problem)	63	99
SRQ Key (front panel)	40	64

NOTE

If the controller does not recognize SRQ, the function can be simulated by performing a read on the instrument after the execution of each operation. The instrument will return an ASCII error message or, if there is no error, the ASCII rubout character (7F hexadecimal, 127 decimal). Thus, if

the response to the read is a single-character message, no error or exception has occurred. If the response is a two-or-more-character message, an error or exception condition exists.

Alternatively, SRQ can be simulated by sending an XT1 command (refer to Section 2.8.5.4) and performing a read. If the response to the read is non-zero, an error or exception condition exists.

2.8.5.4 TALK CODE (XT)

The normal instrument response to a read operation by the controller is the ASCII rubout character (7F hexadecimal, 127 decimal) or an error message character string as explained in Section 2.8.5.3. The instrument response may be changed (for one read operation only) with a Talk Code command as follows:

XT0	No effect. Included for compatibility with other Wavetek instruments.
XT1	Byte which would be sent at Serial Poll. Byte is cleared; pending error message is not affected.
XT2	Value of most recently set parameter.
XT3	Byte which would be sent at Serial Poll. Byte and pending error message are cleared.
XT4	Changes since last Execute
XT5	Instrument identification

2.8.5.5 TALK TERMINATOR (XV)

The terminator of a talk message from the instrument may be varied to suit the controller. When power is applied to the instrument, or when the instrument is reset to its turn-on parameter, the talk terminator is

determined by switch positions 6 and 7 of DIP switch S1 on the GPIB card as follows:

Position 6	Position 7	Terminator
Off	Off	LF/EOI
Off	On	CR LF/EOI
On	Off	Last character/ EOI
On	On	LF only

where LF = ASCII line feed character
CR = ASCII carriage return character
EOI = GPIB end-or-identify line is asserted with the last character

Refer to Figure 2-8.

The talk terminator may be changed as desired from the GPIB by sending an XV command, as follows:

XV0 Use the terminator selected by GPIB card switch S1
XV1 CR LF/EOI
XV2 LF/EOI
XV3 Last character/EOI
XV4 LF only
XV5YYY YYY, where YYY is the decimal equivalent of any ASCII character

If the controller does not read the 3520 properly, try a different termination.

Figure 2-8. Switch S1
(Factory Settings)

2.8.6 SAMPLE PROGRAMS

INTRODUCTION

GPIB ADDRESS AND SELECT CODE

When writing programs for the Model 3520 use the correct GPIB address, and make certain that only one instrument is assigned to that address. It may be helpful to assign the GPIB address near the beginning of a program. For example, on the Wavetek 6000 Instrumentation Computer:

```
130 ...  
140 ! SIG GEN  
150 LET S = 702  
160 ! POWER METER  
170 LET P = 713  
180  
190 WRITE @ S: "F100 MZ"  
200  
210 WRITE @ P: "... .."
```

NOTE: The controller select code is often set to "7", and its bus address set to "21". In sample program lines above the "7" indicates select code, and "02" and "13", the my listen address (MLA).

Mnemonic address forms are also popular. For example, "PWR" for power meter, or "SIG" for signal generator. Their usage depends upon the programmer's preference, and upon the controller's sophistication. Mnemonic and simple variable forms of address permit easy address changes, and may enhance readability of the program.

In order to emphasize the factory setting of the MLA at "2", most of the sample programs that follow use WRITE @ 702 "COMMAND STRING". Of course the user is free to change address as explained in paragraph 2.8.2.

SENDING AN INITIAL MESSAGE

Before proceeding, connect the GPIB cable from the controller interface to the rear-panel GPIB connector on the Model 3520. Turn on the controller and

the Model 3520. Turn on a power meter (or frequency counter) and connect its input to the RF output of the unit.

The following examples are for selected controllers, and need not be sent as a program step. Any GPIB compatible controller can be used, however.

Wavetek 6000:
WRITE @ 702: "F100MZ A10DB 0 BO P11"

HP 85:
OUTPUT 702: "F100MZ A10DB 0 BO P11"

TEK 4051:
PRINT @ 2,32: "F100MZ A10DB 0 BO P11"

HP 9825:
wrt 702, "F100MZ A10DB 0 BO P11"

The Model 3520 front-panel displays should indicate:

```
WAVETEK 3520R
100 MHZ
RF ON (1)
```

Note that the command string (the coding between quotation marks) is identical for each controller. In general, this is the case. Any controller using any valid language will accept identical messages if it is compatible with GPIB specifications.

Monitor the RF output of the instrument with a frequency counter, power meter, modulation meter, or spectrum analyzer. The instruments should indicate within the instrument specifications.

NOTE: Model 3520 parameters are reset at turn on (Section 2.6.1) in a CW mode with the RF output off. The instrument can be reset by pressing the front-panel UNIT RST KEY. On the GPIB the instrument can be reset by sending the code letter "Z" as the command string, or by sending the controller's device clear or selective device clear. If either internal or

external modulation or both have been programmed without unit reset, then, if CW is needed, the code letter "O" should be sent in the command string to clear the internal modulation, and code letters "BO" sent to clear external modulation.

PROGRAMMING HINTS

Begin by writing simple programs to become familiar with programming codes. Refer to front-panel key coding, or to the Table 2-3 at the end of this section. Write coding in the same order as making front-panel entries. In general the order of entries in a command string makes no difference in the execution time. However, if some parameters are held constant while another is varied, it is not necessary to re-execute the constant parameters in a for-next loop, since they are latched in memory until changed.

One can feel assured if measurement data obtained from the RF output of the unit under program control agrees within narrow limits to data obtained manually. If the data do not agree, the program should be examined, and executed by single steps. Programs that do execute properly and yield valid data should be properly structured for future use in subroutines.

USE DELAY TIMES JUDICIOUSLY

Another item of special importance in writing programs for the Model 3520 is the use of delay times. This is especially true of programs written in FORTRAN.

Delays following Model 3520 program statements are necessary to assure satisfactory execution. Using a time delay expressed by a simple variable is recommended. Delay time can be increased or decreased as experience dictates. Some controllers execute more quickly (16 bit) than others (8

bit). The total switching time of an instrument on the GPIB (the time needed for a parameter to be within specified limits) consists of the instrument's microprocessor programming time plus the hardware response time. The time delay inserted into the program should exceed the total switching time. This delay might vary depending upon the user's application as indicated below.

When programming kHz digits > 0 in the output frequency, the switching time is typically 275 ms (75 ms for software, and 200 ms for hardware). If only MHz digits are programmed between 1 and 520 MHz, the switching time is typically 115 ms (75 ms for software and 40 ms for hardware). From 521 to 1040 MHz a frequency doubler is used. Even MHz digits typically switch in 115 ms; odd in 275 ms. Above 1040 MHz a second doubler is used. If the last two MHz digits, (for example, 1996 MHz) divided by 4 is an integer, the switching time is typically 115 ms; if not 275 ms. The phase-locked loop controlling kHz digits is slower than other loops.

VARIETY OF COMMAND STRINGS

A variety of command strings may be used.

Single string: "F100MZ A10DB 0 BO P1I"

Strings & constant: "F100MZ A", 10, "DB 0 BO P1I"

Strings & variable: "F100MZ A"; X, "DB 0 BO P1I" (where X = 10)

Concatenated strings: "F100MZ A" & STR\$(X) & " DB 0 BO P1I (where the variable "X" is expressed as a string)

Single string: "F100E6 A10E0 0 BO P1I" (MZ and DB not used. Executed by final "I")

All the above are valid forms of command strings with the identical meaning when programmed. Spaces between letters are ignored by the Model 3520. They may make the string easier to proof read. The best form to use depends upon the application.

Some controllers operate with the decimal place set by default. If frequency in a command string were expressed as "F", 100.0006, "MZ", the 600 Hz could be lost by rounding to the number of decimal places set by the controller. The problem is solved by using appropriate formatting.

CONTROLLER DIFFERENCES

There are controller differences which prevent direct translation of program statements from one controller to another. As more sophisticated languages, and computers are brought on line, it is the programmer who must decide how an instrument is to be programmed.

SAMPLE PROGRAM PURPOSE

The following sample programs are intended as an introduction to operating the Model 3520 on the GPIB. They may be adapted or merely scanned by reading depending upon the user's experience with bus instruments. A careful study of the controller's GPIB chapter should be helpful.

Although practice seldom makes perfect, it usually improves programming.

FIRST PROGRAM DESCRIPTION

The first program, UP DOWN PARAMETER EXERCISE, is written in BASIC for the Wavetek Model 6000 Instrumentation Computer. It instructs an operator (lines 170-230) to enter any instrument parameter code, and exercise that parameter throughout its range. (Codes are printed on valid keys.)

When the program is run at line #:

120 Strings dimensioned
140 Controller screen cleared
150 3520 reset (SDC)
160 Beep 750 Hz, 200 ms

To "VARIABLE PARAMETER STRING", the operator might respond below at line #:

280 F (A\$, output frequency)
290 100 (B\$, data starting point)
310 MZ (C\$, unit parameter)
320 10 (S\$, data step size)

To "FIXED PARAMETER STRING", the operator might respond below at line #:

360 A-7DB C50% DO P11.

This entry of D\$ remains fixed throughout the test while B\$ is varied by S\$, the step size.

The operator can enter a null string by pressing RETURN without entering D\$. The parameters reset at line 150 would then remain fixed throughout the test.

In lines 410 to 450 the operator receives further instructions.

LOOP (lines 470 to 530)

When the program enters the loop, the variable parameter string is sent to the instrument (line 480), and displayed on the Controller's screen, F100MZ (line 490). Line 500 is an input prompt for the simple variable J.

At line 500 the operator has three choices:

1. Continue to hold down RETURN key (J=0).
2. Enter a new value for J<1E99.
3. Enter 1E99.

The program steps to line 510.

At line 510:

If J=0, program steps to line 520.
If J<0 or J>0, program steps to subroutine at line 550.

At line 520, a new B\$ is computed from the sum of the values of the old B\$ and the step size S\$. (Value B\$=110)

At line 530 the program loops back to line 480 where a frequency of 110 MHz is sent to the 3520.

At line 510 if J ≠ 0, the program steps to the subroutine at line #:

550 If J=1E99 go to end routine.
560 J converted to a string which is equated to S\$
570 J reset to 0
580 Program returned to line 520.

If at line 510 the RETURN key is held down, the program will repeatedly step through the loop, and the output frequency will step from 100 MHz to a maximum of 1040 MHz at which time a double beep is emitted. The operator can then enter -10 at step 500, and the frequency will then step down. (Overshoots can occur, but the program frequency will eventually equal the Model 3520's frequency.

The UP DOWN PARAMETER EXERCISE using the HP9825 is a third version of this program. The program has fewer lines because some of the instructions were omitted, and fewer blank spaces were entered. The operation is very similar to the Wavetek 6000 program.

```
0: "UP DOWN PARAMETER EXERCISE using 9825":
1:
2: dim A#[3],B#[10],C#[10],D#[50],S#[10]
3: fxd 4
4:
5: clr 702
6: beep
7:
8: "VARIABLE PARAMETER":
9: ent "Enter PARAMETER to be varied",A#
10: ent "Enter DATA starting point",B#
11: ent "Enter TERMINATOR string",C#
12: ent "Enter data STEP size",S#
13:
14: "FIXED PARAMETER STRING":
15: ent "Enter FIXED parameter string",D#
16: wrt 702,D#
17: wait 1e3
18:
19: dsp "Hold CONTINUE down to TEST )CONT";beep;stp
20: dsp "Release key to STOP )CONTINUE";stp
21: dsp "To END test enter 1e99 )CONTINUE";stp
22: dsp "VARIABLE STRING is displayed";beep;wait 1e3
23:
24: "loop":
25: wrt 702,A#&B#&C#;dsp A#&B#&C#
26: ent "",J;if J>0 or J<0;gsb +3
27: str(val(B#)+val(S#))>B#;gto -2
28:
29: if J=1e99;gto "end"
30: str(J)>S#;0>J
31: ret
32:
33: "end":beep;dsp "END"
34: end
*27060
```



```

100 ! UP DOWN PARAMETER EXERCISE using 6000
110 !
120 DIM A#*3,B#*10,C#*10,D#*50,S#*10
130 !
140 CLEAR
150 DCL @702
160 BEEP 750,200
170 PRINT "THIS PROGRAM EXERCISES THOSE PARAMETERS ON THE GPIB"
180 PRINT "THAT AN OPERATOR EXERCISES AT THE MODEL 3520 FRONT-"
190 PRINT "PANEL. ANY VALID PARAMETER CAN BE ENTERED, AND STEPPED"
200 PRINT "THROUGH ITS RANGE BY HOLDING DOWN THE RETURN KEY. IF"
210 PRINT "THE KEY IS RELEASED, A NEW STEP SIZE (+ OR -) CAN THEN"
220 PRINT "BE ENTERED AND STEPPING RESUMED. IF A DOUBLE BEEP IS"
230 PRINT "EMITTED, A STEP REVERSAL IS INDICATED."
240 PRINT ""
250 !
260 ! VARIABLE PARAMETER STRING
270 PRINT "Enter PARAMETER to be varied. (See front-panel codes):"
280 INPUT PROMPT "A, F, C, D, T, BC, or BD, etc":A#
290 INPUT PROMPT "Enter data STARTING point:":B#
300 PRINT "Enter TERMINATOR string:"
310 INPUT PROMPT "DB, VQ, MV, UV, HZ, KZ, MZ, or %, etc":C#
320 INPUT PROMPT "Enter data STEP size:":S#
330 PRINT ""
340 !
350 ! FIXED PARAMETER STRING
360 INPUT PROMPT "Enter FIXED parameter string:":D#
370 PRINT ""
380 WRITE @702:D#
390 WAIT DELAY 1
400 !
410 PRINT "Hold RETURN key down to TEST. Release to STOP."
420 PRINT "To END TEST enter 1E99."
430 PRINT ""
440 PRINT "VARIABLE STRING is displayed below:"
450 BEEP 750,200
460 !
470 ! LOOP
480 WRITE @702:A#&B#&C#
490 PRINT A#&B#&C#
500 INPUT PROMPT "":J
510 IF J>0 OR J<0 THEN GO SUB 550
520 LET B#=STR$(VAL(B#)+VAL(S#))
530 GO TO 480
540 !
550 IF J=1E+99 THEN GO TO 600
560 LET S#=STR$(J)
570 LET J=0
580 RETURN
590 !
600 PRINT ""
610 PRINT "END OF PROGRAM"
620 END

```

```

100 ! UP DOWN PARAMETER TEST
110 !
120 DIM A#[3],B#[10],C#[10],D#[5
0]
130 CLEAR
140 CLEAR 702
150 BEEP
160 !
170 ! VARIABLE PARAMETER STRING
180 DISP "Enter PARAMETER to be
varied"
190 DISP "A, F, C, D, T, BC, or
BD, etc:";
200 INPUT A#
210 DISP "Enter data STARTING po
int:";
220 INPUT B#
230 DISP "Enter UNIT (terminator
) string:"
240 DISP "DB, VD, MV, KZ, MZ, %,
etc:";
250 INPUT C#
260 DISP ""
270 DISP "Enter data STEP SIZE:"
;
280 INPUT S
290 DISP ""
300 !
310 ! FIXED PARAMETER STRING
320 DISP "Enter FIXED parameter
string";
330 INPUT D#
340 OUTPUT 702 ;D#
350 DISP ""
360 WAIT 1000
370 !
380 I=VAL(B#)
390 DISP "Press CONT key to TEST
"
400 DISP "Press RESET key to END
TEST."
410 DISP "Enter S= +/- xx to CHA
NGE step."
420 DISP ""
430 DISP "VARIABLE STRING displa
yed below:"
440 BEEP
450 !
460 ! LOOP
470 OUTPUT 702 ;A#&VAL#(I)&C#
480 DISP A#&VAL#(I)&C#
490 PAUSE
500 I=I+S
510 GOTO 470
520 !
530 END

```

The UP DOWN PARAMETER test using the HP85 as a controller is another version of the UP DOWN PARAMETER EXERCISE using the Wavetek 6000. Even though both programs are written in BASIC, there are noticeable differences when comparing the two. In response to an INPUT PROMPT statement in a program loop on the Wavetek 6000, the RETURN key can be held down without a keyboard entry. This permits an operator to stop or to continue stepping through the loop as desired. The INPUT key on the HP85 does require an entry, and a CONT key response. To simplify operation the PAUSE key was used (line 490) in place of the INPUT key. However, the PAUSE key cannot be held down, but must be released to continue in the loop. Otherwise the program executed similarly.

The AUTOSWEEP program is similar to the first program, but adds the following:

1. Automatically sweeps any parameter up or down using a for-next loop with START and STOP limits and step size entered by the user.
2. User may add a second bus instrument, a talker (lines 330 and 460).
3. Arrays are dimensioned for data storage: X for 3520 (line 430) and Y for talker (line 460).

```
100 ! AUTOSWEEP using WAVETEK 6000
110 !
120 DIM A#*3,B#*10,C#*10,D#*50,X(500),Y(500)
130 CLEAR
140 DCL @702
150 BEEP 750,200
160 !
170 ! VARIABLE PARAMETER STRING
180 PRINT "Enter PARAMETER to be varied:"
190 INPUT PROMPT "A, F, C, D, T, BC, or BD, etc":A#
200 INPUT PROMPT "Enter START value of parameter":A1
210 INPUT PROMPT "Enter STOP value of parameter":A2
220 PRINT "Enter TERMINATOR string:"
230 INPUT PROMPT "DB, VD, MV, UV, HZ, KZ, MZ, or %, etc":C#
240 INPUT PROMPT "Enter data STEP size":S
250 IF A1>A2 THEN LET S=-S
260 !
270 ! FIXED PARAMETER STRING
280 INPUT PROMPT "Enter FIXED parameter string":D#
290 WRITE @702:D#
300 !
310 ENTER PROMPT "Enter DELAY in SECONDS for 3520":W1
320 PRINTER IS @704
330 !WRITE @7XX:"String for 2nd UNIT on bus"
340 ENTER PROMPT "Enter DELAY in SECONDS for 2nd UNIT":W2
350 !
360 PRINT "OBSERVE INSTRUMENT READINGS"
370 BEEP 750,200
380 !
390 ! LOOP
400 LET K=0
410 FOR I=A1 TO A2 STEP S
420 LET K=K+1
430 LET X(K)=I
440 WRITE @702:A#&STR#(I)&C#
450 WAIT DELAY W1
460 ! READ @7XX: Y(K)
470 WAIT DELAY W2
480 NEXT I
490 !
500 BEEP 750,200
510 WAIT DELAY .2
520 PRINT "END OF ROUTINE"
530 END
```

The TALK ROUTINE demonstrates the ability of the Model 3520 to return the latest parameter. The user inputs a valid parameter string. The controller sends the string to the instrument at line 300. The controller sends the talk code "XT2" at line 350. The instrument reads the return string at line 370, and prints it at line 390. See 2.8.5.4.

A typical printout might read:

EXECUTED BY CONTROLLER WRITE @ 702: "A-127DB"

STRING RETURNED BY TALK COMMAND: LEV -127.0 DBM

```
100 ! TALK ROUTINE
110 !
120 DIM A#*3,B#*10,C#*5,T#*50
130 !
140 ! UNIT RESET
150 WRITE @702:"Z"
160 WAIT DELAY 2
170 !
180 BEEP 750,200
190 WAIT DELAY .2
200 !
210 ! ENTER
220 PRINT "Enter 3520 front-panel CODE for parameter:"
230 PRINT ""
240 INPUT PROMPT ""F"" for FREQ, ""A"" for LEVEL, ""C"" for AM, etc":A#
250 PRINT ""
260 INPUT PROMPT "Enter DATA to be programmed":B#
270 PRINT ""
280 INPUT PROMPT "Enter TERMINATOR: MZ, DB, %, etc":C#
290 PRINT ""
300 WRITE @702:A#&B#&C#
310 WAIT DELAY .2
320 PRINT "EXECUTED BY CONTROLLER:"
330 PRINT "WRITE@702: ""&A#&B#&C#&""""
340 PRINT ""
350 WRITE @702:"XT2"
360 WAIT DELAY .2
370 READ @702:T#
380 PRINT "STRING RETURNED BY TALK COMMAND:"
390 PRINT T#
400 BEEP 750,200
410 WAIT DELAY .2
420 PRINT ""
430 PRINT "END OF ROUTINE"
440 END
```

The STORE SETTINGS program enables the user to duplicate on the GPIB at the controller keyboard the storage routine at the instrument front panel (Section 2.7.8). As shown in Table 2-2 there are 32 memory locations available to the user.

In the following RECALL SETTINGS program the user may recall any of the following locations:

001 - 032	all parameters	401 - 457	See Table 2-2
101 - 132	all modulation	501 - 538	See Table 5-1
201 - 232	main frequency	601 - 604	See Table 4-2
301 - 332	on/off level		

```
100 ! STORE SETTINGS: USER MEMORY
110 !
120 CLEAR
130 DIM A#*50
140 FORMAT:C1,FZ3,C1
150 !
160 ! ENTER
170 BEEP 750,200
180 WAIT DELAY .2
190 INPUT PROMPT "Enter FIRST MEMORY location":M1
200 INPUT PROMPT "Enter LAST MEMORY location":M2
210 IF M1<1 OR M1>32 OR M2<M1 OR M2>32 THEN 170
220 PRINT ""
230 !
270 PRINT "Enter STRINGS in form:"
280 PRINT "F100MZ A10DB C100% T1KZ B0 P1I"
290 PRINT ""
300 LET T=.5
310 !
320 ! LOOP
330 FOR I=M1 TO M2
340 PRINT "Enter STRING for Memory location",I
350 INPUT PROMPT "":A#
360 WRITE @702:A#
370 WAIT DELAY T
380 WRITE @702 USING 140:"M",I,"I"
390 WAIT DELAY T
410 PRINT ""
420 NEXT I
430 !
460 BEEP 750,200
470 WAIT DELAY .2
480 PRINT "END OF ROUTINE"
490 END
```

```

100 ! RECALL SETTINGS: USER MEMORY
110 !
120 CLEAR
130 DIM A#*50
140 FORMAT:C1,FZ3,C1
150 LET T=.25
160 BEEP 750,200
170 WAIT DELAY .2
180 !
190 ! ENTER
200 INPUT PROMPT "Enter FIRST MEMORY location":M1
210 INPUT PROMPT "Enter LAST MEMORY location":M2
220 PRINT ""
230 !
240 ! SET SRQ
250 WRITE @702:"XQ1"
260 !
270 ! LOOP
280 FOR I=M1 TO M2
290 PRINT "Memory location",I
300 WRITE @702 USING 140:"Y",I,"I"
310 WAIT DELAY T
320 STATUS @702:S
330 WAIT DELAY 2*T
340 IF S>63 THEN GO SUB NOT
350 WRITE @702:"XFF"
360 WAIT DELAY T
370 !
380 ! READ FREQ
390 READ @702:A#
400 PRINT A#
410 WRITE @702:"XPA"
420 WAIT DELAY T
430 !
440 !READ LEVEL
450 READ @702:A#
460 PRINT A#
470 IF I=M2 THEN 590
480 PRINT ""
490 INPUT PROMPT "Press RETURN for NEXT location":I
500 NEXT I
510 !
520 NOT: PRINT
530 PRINT "NOT A MEMORY LOCATION."
540 PRINT "DATA FOR LAST RECALLED:"
550 BEEP 1000,200
560 WAIT DELAY .2
570 RETURN
580 !
590 PRINT ""
600 BEEP 750,200
610 WAIT DELAY .2
620 PRINT "END OF ROUTINE"
630 END

```

The STORE SETTINGS #2 program provides a different approach to storing settings in memory locations 1 to 32. The command strings (lines 210 to 320 in steps of 3) are examples only. The user would type the program with his settings and store the entire program on disc or tape. If the front-panel settings were changed, the original program could be run with the original settings. Any number of users with their separate lists could be stored as needed. The initial program with its utility for one group of settings, could be replicated many times thereby increasing the utility of the instrument.

```
100 ! STORE SETTINGS: #2
110 !
120 ! RESET UNIT
130 WRITE @702:"Z"
140 WAIT DELAY 2
150 !
160 ! DATA STORAGE ROUTINE
170 PRINT "Storing command strings"
180 PRINT ""
190 BEEP 750,200
200 LET W=.2
210 WRITE @702:"F1400KZ A10.3DB 0 BO P1I"
220 WAIT DELAY W
230 WRITE @702:"M001I"
240 WAIT DELAY W
250 WRITE @702:"F10MZ A3DB C50% T2.2KZ BO P1I"
260 WAIT DELAY W
270 WRITE @702:"M002I"
280 WAIT DELAY W
290 !WRITE @702:"ENTERED BY USER"
300 WAIT DELAY W
310 !WRITE @702:"M003I"
320 WAIT DELAY W
330 !WRITE @702:"ENTERED BY USER"
340 WAIT DELAY W
350 !WRITE @702:"M004I"
360 !
370 ! MAKE ENTRIES AS ABOVE IF NEEDED
380 !
390 IFC @7
400 WAIT DELAY 2
410 BEEP 750,200
420 WAIT DELAY .2
430 PRINT "END OF ROUTINE"
440 END
```

The **FREQ DIGIT TEST** program exercises each digit from 100 Hz to 100 MHz beginning at 1 MHz and concluding at 1040 MHz. It is similar to the manual test in Section 4.2. It permits a test of the 3520 **FREQUENCY** display and internal programming lines. The user can autosweep, or step through the range. Some controllers permit the user to stop and then continue during autosweep.

```
100 ! FREQ DIGIT TEST
110 !
120 CLEAR
130 FORMAT:C1,F9.4,C2
140 BEEP 750,200
150 INPUT PROMPT "Enter ""0"" for AUTOSWEEP, ""1"" for STEP":S
160 IF S=1 THEN PRINT "Press RETURN to TEST"
170 IF S=0 THEN INPUT PROMPT "Enter WAIT TIME in SECONDS":T
180 !
190 WRITE @702:"F1MZ A0DB 0 P1I"
200 WAIT DELAY T
210 PRINT "NOTE 3520 FREQUENCY DISPLAY"
220 !
230 LET F=1
240 LET N=9
250 !
260 ! LOOPS
270 FOR J=-4 TO 3
280 FOR I=1 TO N
290 WRITE @702 USING 130:"F",F+I*10^J,"MZ"
300 IF S=1 THEN PRINT F+I*10^J;
310 IF S=1 THEN INPUT PROMPT "":K
320 IF S=0 THEN WAIT DELAY T
330 NEXT I
340 IF J=-1 THEN LET F=0
350 IF J=2 THEN LET N=2
360 NEXT J
370 !
380 BEEP 750,200
390 WAIT DELAY .2
400 PRINT "END OF ROUTINE"
410 END
```

The MILLIVOLT OUTPUT program enables the user to program the instrument in millivolts rms (0.001 to 1000 mV) between any two limits in any step size. The 50 ohm equivalent in dBm is displayed on the controller screen.

```
100 ! MILLIVOLT OUTPUT
110 !
120 ! Steps between START and STOP entries.
130 ! Calculates equivalent level in dBm."
140 !
150 CLEAR
160 FORMAT:C1,F10.4,C2
170 BEEP 750,200
180 WAIT DELAY .2
190 !
200 INPUT PROMPT "Enter CARRIER FREQ in MHz":F
210 INPUT PROMPT "Enter TIME DELAY in SECONDS":T
220 INPUT PROMPT "Enter START level in millivolts":L1
230 INPUT PROMPT "Enter STOP level in millivolts":L2
240 INPUT PROMPT "Enter STEP SIZE in millivolts":S
250 IF L1>L2 THEN LET S=-S
260 !
270 WRITE @702:"F",F,"MZ 0 80 P11"
280 WAIT DELAY T
290 PRINT ""
300 IMAGE:####.#### +####.##
310 PRINT " OUTPUT LEVEL"
320 PRINT " mV dBm"
330 PRINT "-----"
340 !
350 ! LOOP
360 FOR I=L1 TO L2 STEP S
370 WRITE @702 USING 160:"A",I,"MV"
380 WAIT DELAY T
390 PRINT USING 300:I,10*LOG10(.001*I^2/50)
400 NEXT I
410 !
420 IFC @7
430 BEEP 750,200
440 WAIT DELAY .2
450 PRINT ""
460 PRINT "END OF ROUTINE"
470 END
```

The SRQ: SERVICE REQUEST program demonstrates the utility of this bus command using the serial poll routine. Each bus device would be polled serially, but in this program the status byte is returned (line 760 - 820) for the GPIB address 702. When the program is run the status bytes should conform to the results in Section 2.8.5.3. In writing programs for SRQ, some controllers interrupt the normal routine, read the status byte of each bus device, and react according to the byte or bytes returned. If "99" stop test, for example.

```
100 ! SRQ: SERVICE REQUEST
110 !
120 CLEAR
130 BEEP 750,200
140 WAIT DELAY .2
150 PRINT "When conducting a SERIAL POLL on the GPIB, the"
160 PRINT "controller READS STATUS (DIO lines 1 through 8)."
```



```

440 ! %AM TOO HIGH: 100% at +10 dBm
450 GO SUB PROMPT
460 GO SUB RESET
470 WRITE @702:"F500MZ A10DB C100% P1I"
480 WAIT DELAY 5*T
490 PRINT "HARDWARE PROBLEM: ""A10DB C100%""
500 PRINT "%AM TOO HIGH at +10 dBm"
510 GO SUB STATUS
520 !
530 ! 3510 SRQ KEY
540 GO SUB PROMPT
550 IFC @7
560 GO SUB RESET
570 BEEP 750,200
580 INPUT PROMPT "Press 3520 SRQ key, then RETURN key":I
590 WRITE @702:"F123.4567MZ A10DB 0 P1I"
600 PRINT "OPERATOR INITIATES SERVICE REQUEST"
610 GO SUB STATUS
620 GO TO 840
630 !
640 RESET: PRINT
650 WRITE @702:"Z"! RESET UNIT
660 WAIT DELAY 2*T
670 WRITE @702:"X01"! RESET SRQ
680 WAIT DELAY T
690 RETURN
700 !
710 PROMPT: PRINT
720 BEEP 750,200
730 INPUT PROMPT "Press RETURN for next SRQ TEST":I
740 RETURN
750 !
760 STATUS: PRINT
770 WAIT DELAY T
780 STATUS @702:S1
790 WAIT DELAY T
800 PRINT "STATUS BYTE: ",BSTR$(S1,8),S1
810 PRINT "*****"
820 RETURN
830 !
840 BEEP 750,200
850 WAIT DELAY .2
860 PRINT "END OF ROUTINE"
870 END

```

The TRIGGER TEST program uses the "XG1" command (Section 2.8.5.1) at line 170 to "ARM" the trigger. The Wavetek 6000 permits a selective device trigger (line 230), and a group execute trigger (line 300) to "turn on" the RF output of the instrument. Note that the RF output must be turned off (line 140 by selective device clear) (line 280 by "POI") before P1 is set. The execute terminator "I" (line 390) is used as a trigger (lines 340 - 390). "I" does not need to be armed (line 350). The other trigger methods are generally faster.

```
100 ! TRIGGER TEST
110 !
111 PRINT "Observe LEVEL display"
112 BEEP 600,200
120 DCL @702
130 LET T=1
140 WAIT DELAY T
150 !
160 ! ARM TRIGGER
170 WRITE @702:"XG1"
180 WAIT DELAY T
190 !
200 ! DEVICE TRIGGER
210 WRITE @702:"F1000MZ A10DB P1"
220 WAIT DELAY T
230 TRG @702
240 BEEP 700,200
250 !
260 ! GROUP EXECUTE TRIGGER
270 WAIT DELAY T
280 WRITE @702:"POI P1"
290 WAIT DELAY T
300 COMMAND @7:CHR#(8)! GET
310 BEEP 800,200
320 !
330 ! EXECUTE USING "I"
340 WAIT DELAY T
350 WRITE @702:"XG0"
360 WAIT DELAY T
370 WRITE @702:"P0 P1"
380 WAIT DELAY T
390 WRITE @702:"I"
420 BEEP 900,200
421 !
430 WAIT DELAY .2
450 END
```

The CIRCUIT BREAKER TEST program is performed with a 50 ohm load connected to the RF output. The CB is tested at a lower threshold level than the normal overload using the "ROI" command (line 290). This test duplicates the action of the front-panel OUT RST key. See item (10) in Section 2.4.1 and 2.7.12. Since the unit recognizes the open breaker as a hardware error, a double beep should be emitted, the LEVEL should indicate CB TRIPPED, and the RF output should turn off. The status byte at line 360 should be decimal 99. The CB is reset by sending "RII".

```
100 ! CB: CIRCUIT BREAKER TEST
110 !
120 ! 50 ohm LOAD to RF OUT
130 LET T=1
140 DCL @702
150 WAIT DELAY T
160 !
170 ! SET SRQ
180 WRITE @702:"XQ1"
190 BEEP 750,200
200 !
210 PRINT "Enter FREQUENCY in MHz"
220 INPUT PROMPT "":F
230 !
240 ! LEVEL +10 dBm
250 WRITE @702:"F"&STR$(F)&"MZ A10DB P1I"
260 WAIT DELAY 3*T
270 !
280 ! CB TEST
290 WRITE @702:"ROI"
300 WAIT DELAY 2*T
310 PRINT ""
320 PRINT "RF OFF and CB TRIPPED?"
330 PRINT ""
340 !
350 STATUS @702:S1
360 WAIT DELAY T
370 PRINT "STATUS BYTE",BSTR$(S1,8),S1
380 ! S1= 99 ?
390 !
400 PRINT ""
410 BEEP 750,200
420 WAIT DELAY .2
430 !
440 ! RESET CB
450 INPUT PROMPT "Enter "RII" and RETURN to RESET.":A#
460 WRITE @702:A#
470 !
480 END
```

The GPIB: GENERAL BUS UTILITY program demonstrates the response of the instrument to the controller commands listed in lines 160 to 210. The GET (see TRIGGER TEST) is also in this group. It is helpful if a spectrum analyzer or power meter is connected to the unit's RF output to monitor the responses. These commands are useful to the programmer in addition to the "write" and "read" statements. Some think of the GPIB as having two modes. A command mode for general interface management, and a data mode when data messages are sent on the data bus.

```
100 ! GPIB: GENERAL BUS UTILITY
110 !
120 CLEAR
130 PRINT "GENERAL UTILITY ROUTINES INCLUDE:"
140 PRINT "-----"
150 PRINT ""
160 PRINT "REN (remote enable)"
170 PRINT "LCL (go to local)"
180 PRINT "LLO (local lockout)"
190 PRINT "DCL (device clear)"
200 PRINT "SDC (selective device clear)"
210 PRINT "IFC (interface clear)"
220 !
230 WRITE @702:"Z"
240 WAIT DELAY 2
250 GO SUB PROMPT
260 !
270 ! REN: Remote ENable
280 REN @702
290 PRINT "Controller sends ... REN @702"
300 GO SUB DISPLAY
310 PRINT "REMOTE OPERATION  R"
320 !
330 GO SUB PROMPT
340 !
350 ! LCL @702
360 LCL @702
370 PRINT "Controller sends ... LCL @702"
380 GO SUB DISPLAY
390 PRINT "LOCAL OPERATION"
410 GO SUB PROMPT
420 !
```

```

430 ! LOCAL LOCKOUT
440 WRITE @702:"P1I F111.2222MHZ A-3.3 C90% T5KZ B0"
450 WAIT DELAY 1
460 PRINT "Controller sends:"
470 PRINT "WRITE @702:""P1I F111.2222 MHZ A-3.3DB C90% T5KZ B0""
480 LLO @7
490 WAIT DELAY 1
500 PRINT ""
510 PRINT "Controller sends ... LLO @7"
520 GO SUB DISPLAY
530 PRINT "MOD/GPIB:    MOD RATE 5 KHZ      R"
540 PRINT "FREQUENCY:    111.2222 MHZ"
550 PRINT "LEVEL:        -3.3 DBM"
560 PRINT ""
570 PRINT "NOTE: 3520 KEYBOARD WILL NOT ACCEPT"
580 PRINT "      OPERATOR ENTRIES!"
600 GO SUB PROMPT
610 !
620 ! SELECTIVE DEVICE CLEAR
630 DCL @702
640 PRINT "Controller sends ... DCL @702"
650 GO SUB DISPLAY
660 PRINT "WAVETEK MODEL 3520"
670 PRINT ""
680 PRINT "NOTE: OPERATOR CAN NOW SELECT"
690 PRINT "      FRONT-PANEL KEYS."
700 PRINT ""
710 BEEP 750,200
720 WAIT DELAY .2
730 PRINT "PLEASE MAKE NEW FRONT-PANEL ENTRIES,"
740 INPUT PROMPT "and then press RETURN key.":I
750 !
760 ! STORE SETTINGS at 001
770 WRITE @702:"M001I"
780 CLEAR
790 !
800 ! DEVICE CLEAR
810 DCL @7
820 PRINT "Controller sends ... DCL @7"
830 PRINT ""
840 PRINT "DOOPS! too bad the Controller CLEARED your"
850 PRINT "entries. But they were STORED at location"
860 PRINT "001, and we will RECALL them later!"
870 PRINT ""
880 GO SUB DISPLAY
890 PRINT "MOD/GPIB:    WAVETEK MODEL 3520"
900 PRINT "FREQUENCY:    260 MHZ"
910 PRINT "LEVEL:        0 DBM      *"
920 PRINT ""
930 PRINT "NOTE: DCL @7, DCL @702, and WRITE @702:""Z""
940 PRINT "      perform UNIT RESET, the same as the "
950 PRINT "      front-panel UNIT RST key."

```

```

960 !
970 GO SUB PROMPT
980 !
990 ! RECALL SETTINGS at location 001
1000 WRITE @702:"Y0011"
1010 WAIT DELAY 1
1020 PRINT "Controller sends ... WRITE @702:""Y0011""
1030 !
1040 ! GO TO LOCAL
1050 LCL @702
1060 PRINT "Computer sends ... LCL @702"
1070 PRINT ""
1080 PRINT "Press 3520 STAT key to check"
1090 PRINT "your entries. Settings recalled"
1100 PRINT "from memory location 001."
1110 GO SUB PROMPT
1120 !
1130 ! INTERFACE CLEAR
1140 WRITE @702:"T2.5KZ D55.5KZ B0 F1000MZ A0DB P1I"
1150 WAIT DELAY 1
1160 PRINT "Controller sends:"
1170 PRINT "WRITE @702:""T2.5KZ D55.5KZ B0 F1000MZ A0DB P1I""
1180 PRINT ""
1190 IFC @7
1200 PRINT "Controller sends ... IFC @7"
1210 GO SUB DISPLAY
1220 PRINT "MOD/GPIB          LOCAL OPERATION"
1230 PRINT "FREQUENCY:          1000 MHZ"
1240 PRINT "LEVEL:              0 DBM"
1250 PRINT ""
1260 PRINT "NOTE: IFC @7 (interface clear) returns 3520 to"
1270 PRINT "          LOCAL, but parameters are not affected."
1280 GO SUB PROMPT
1290 !
1300 BEEP 750,200
1310 GO TO END
1320 !
1330 PROMPT: PRINT
1340 BEEP 750,200
1350 WAIT DELAY .2
1360 INPUT PROMPT "Press RETURN key for next GPIB operation.":I
1370 CLEAR
1380 RETURN
1390 !
1400 DISPLAY: PRINT
1410 PRINT "3520 FRONT-PANEL should indicate:"
1420 RETURN
1430 !
1440 END: PRINT
1450 PRINT ""
1460 INPUT PROMPT "Enter ""0"" to END, or ""1"" to REPEAT":I
1470 IF I=1 THEN GO TO 100
1480 END

```

<u>ITEM</u>	<u>CODE</u>	<u>ITEM</u>	<u>CODE</u>
Output		Frequency	
Level	A	Hz	HZ
Frequency	F	kHz	KZ
		MHz	MZ
Power		Data	
Not Executed		Digits	0-9
RF on	P1	Exponential	
RF off	P0	10 ^N	EN
Executed		Decimal Point	.
RF on	P1I	Sign	-
RF off	POI		
CW (LETTER "O")		X Commands	
Internal	O	GET (2.8.5.1)	
External	BO	Disable	XG0
		Execute	XG1
		Call next	
		stored setting	XG2
Modulation		Parameter Values (2.8.5.2)	
Internal		Output level	XPA
AM	C	External AM	XPBC
FM	D	External FM	XPBD
Rate	T	Internal AM	XPC
External		Internal FM	XPD
AM	BC	Output Frequency	XPF
FM	BD	Modulation Rate	XPT
Not Executed		Service Request (2.8.5.3)	
ALC on	V1	Disable	XQ0
ALC off	V0	Enable	XQ1
Executed			
ALC on	V1I	Talk (2.8.5.4)	
ALC off	VOI	No effect	XT0
		Serial poll:	
Circuit Breaker (2.7.12)		Byte only cleared	XT1
Not Executed		Latest param value	XT2
R1	R1	Serial poll:	
R0	R0	Byte + message cleared	XT3
Executed		Changes since	
R1I	R1I	last execute	XT4
ROI	ROI	Wavetek 3520	XT5
		Talk Terminator (2.8.5.5)	
Memory (2.7.8)		Selected by S1	XV0
Store	MXXXI	CR/LF/EOI	XV1
Recall	YXXXI	LF/EOI	XV2
		Last char/EOI	XV3
Misc (2.8.4)		LF only	XV4
Execute	I	ASCII decimal	
Terminator	;	char YYY	XV5YYY
Local	Q		
Unit Reset	Z		
AM depth	%		
Units (2.8.4)			
Level			
dBm	DB		
Vrms	VO		
mVrms	MV		
μVrms	UV		

Table 2-3. GPIB Code Summary

3.1 INTRODUCTION

The signal generator can be divided into two main operational sections; the control section and the RF generating section. An overall view of each operational section will be given.

Detailed circuit descriptions are included in Section 3 of the Service Manual.

3.2 DIGITAL CONTROL SECTION OVERVIEW

Refer to Figure 3-1.

The two main purposes of the digital section are to monitor input data from the front-panel keyboard and rear-panel GPIB in order to determine what the output settings of the instrument should be, and then to control the RF generating section.

Digitally encoded data is sent to the analog control section where the data is transformed into control voltages. These voltages are routed to the individual modules of the RF section where the control actually takes place. Besides controlling the RF parameters and monitoring the keyboard and GPIB, the Digital section also sends data to the front panel displays, and writes data out the rear panel GPIB.

The digital control section consists of four PC boards. They are the Multi-function card, the Analog Control microprocessor card, the input/output (I/O) microprocessor card and the display board.

3.3 RF GENERATING SECTION OVERVIEW

Refer to Figure 3-2.

A 40 MHz crystal-controlled oscillator generates the reference frequency for the RF section of this instrument. The wide and narrow oscillators are varactor-tuned and indirectly phase-locked to this reference. The wide oscillator (1199 to 1718 MHz) and the narrow oscillator (1198 MHz) are mixed, and their difference frequencies are tunable over the range of 1 to 520 MHz. The narrow oscillator can be frequency modulated.

The difference frequency from the mixer is amplified and leveled by a wideband amplifier (WBA). Below 521 MHz the leveled output is switched under microprocessor control to the 0 - 130 dB step attenuator, and through the RF circuit breaker to the front-panel RF output.

Two frequency doublers are switched into the output system above 520.9999 MHz. The first doubler, which selects the second harmonic of the first WBA, operates from 521.0000 to 1039.9999 MHz with a minimum step size of 100 Hz. The second doubler, which selects the second harmonic of the first doubler, operates from 1040.0000 to 2080.0000 MHz with a minimum step size of 200 Hz.

3.3.1 RF GENERATION

The RF output frequency is generated by two UHF oscillators and a mixer. The outputs of the two oscillators are heterodyned in the mixer. The difference frequency is amplified and fed to an output amplifier.

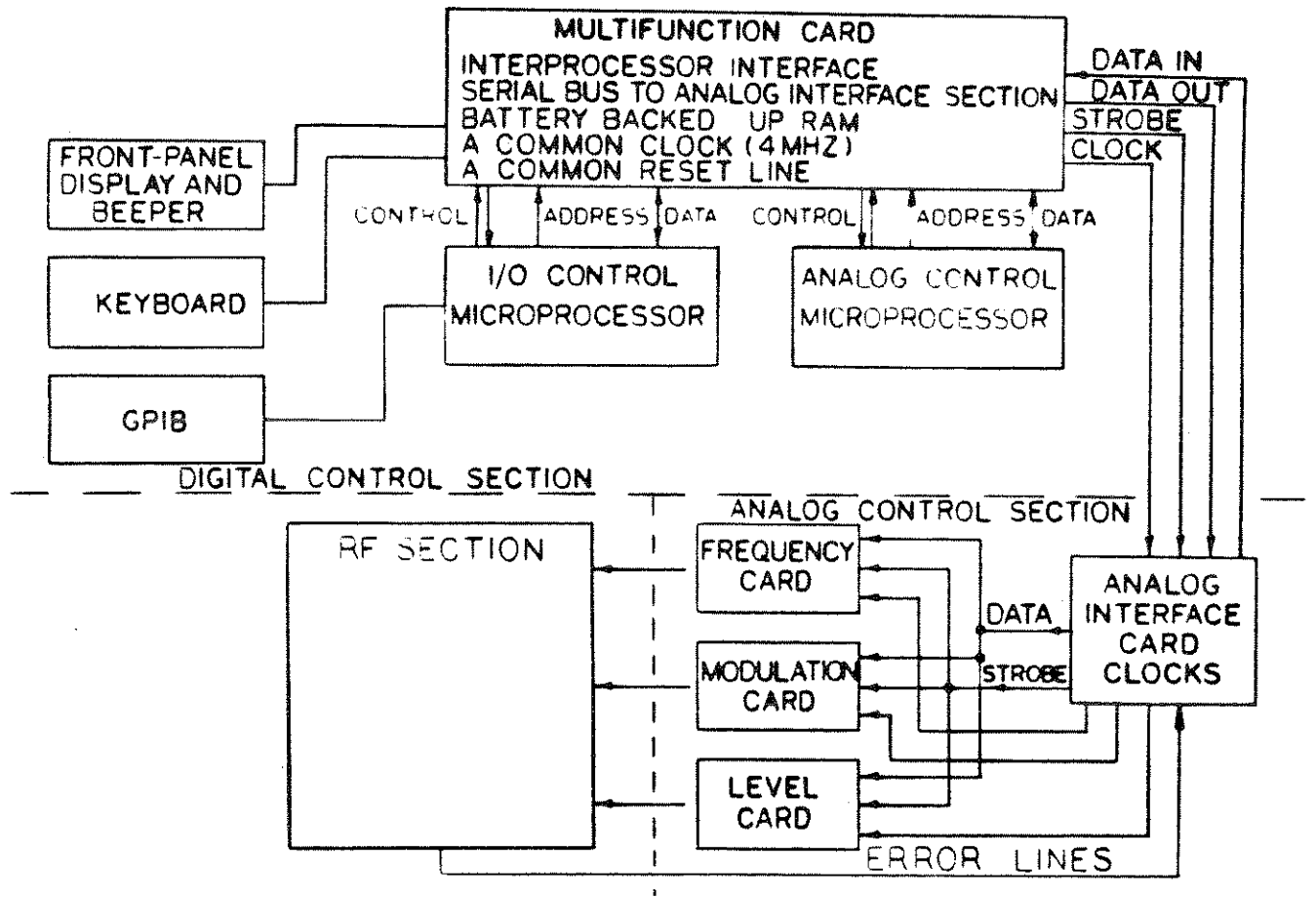

Figure 3-1. Overall Block Diagram

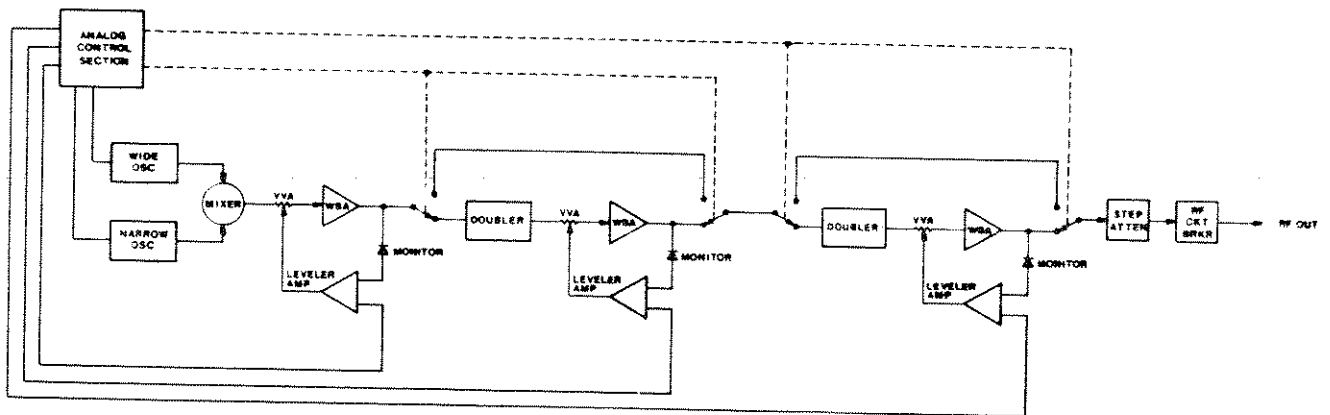

Figure 3-2 R.F. Section

The frequencies of these oscillators are controlled by DC voltages applied to their varactor diodes. The narrow oscillator yields a single frequency. The wide oscillator can be programmed over a range which extends from the frequency of the narrow oscillator to 520 MHz higher than the narrow oscillator frequency.

3.3.2 RF FREQUENCY CONTROL

The RF output frequency is determined by programming the frequency of the wide oscillator. The wide oscillator is ultimately controlled by the digital control section. The digital input is converted to an analog voltage which programs the oscillator in 1 MHz steps. This analog signal can provide approximately 3 MHz accuracy.

3.3.3 RF AMPLIFICATION AND LEVELING

The RF power is amplified by a multi-stage, wideband amplifier. The flat output is maintained by a closed-loop leveling system around this amplifier.

The leveler includes a monitor diode, an error amplifier, and a voltage-variable attenuator. The monitor detects the peak output of the amplifier. This detected level is compared to a DC reference by the error amplifier. The output of the error amplifier is fed to a PIN diode (voltage-variable) attenuator which changes the input level to the amplifier until the monitored signal produces a DC level equal to the reference level.

3.3.4 LEVEL CONTROL AND AM

The circuitry for controlling the RF output level is directly related to the leveling system because changing the DC level reference changes the RF output level.

Of the 150 dB output range, 130 dB is passive attenuation. The remaining 20 dB is controlled by changing the level reference.

Since the RF level can be voltage controlled, AM can be accomplished by applying the modulating signal to the leveling circuit. This causes the reference voltage to the error amp to change at the frequency of the modulating signal. The modulating signal is taken from either an internal oscillator or an external source.

3.4 PHASE-LOCKED LOOPS

The RF generation circuitry discussed above has a frequency range of 1 to 520 MHz, has an output voltage which is leveled and adjustable, and has the ability to be amplitude modulated. With the above circuitry, however, the frequency accuracy is only 3 MHz with 1 MHz resolution. To achieve the desired resolution and accuracy, the instrument includes five phase-locked loops.

PLL 1, 2, and 4 are used to stabilize the wide oscillator and tune it in 1 kHz steps. The wide oscillator is part of PLL 4. PLL 1 and 2 convert the digital input to reference frequencies for PLL 4.

PLL 3 and 5 provide stabilization to the narrow oscillator and allow FM operation. The narrow oscillator is part of PLL 3. PLL 5 converts a modulating signal (if present) to a reference frequency for PLL 3. PLL 5 is also used to program 100 Hz offset steps into the narrow oscillator for 100 Hz resolution.

Figure 3-3 illustrates the relationships between the five phase-locked loops.

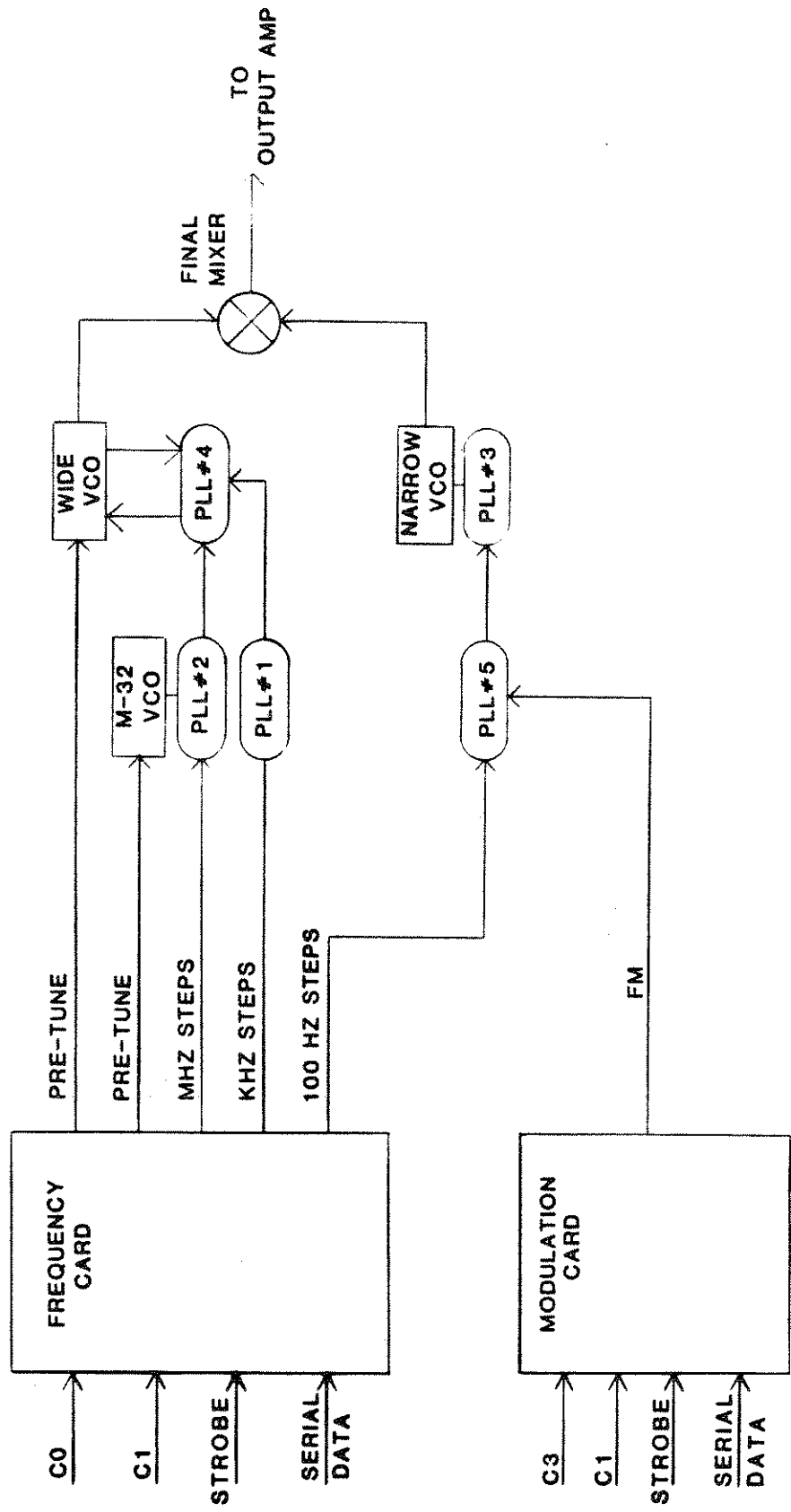

Figure 3-3. PLL Relationships

4.1 INTRODUCTION

The purpose of the performance tests in the following sections is to verify that the Signal Generator meets its published specifications (Section 1.2). Individual performance tests consist of: the specification to be verified; the method of testing; a list of equipment required; and a detailed test procedure including, in some cases, a simplified setup drawing. If optional features are installed in the instrument, refer to Section 8 for possible changes to the performance test procedure.

Critical specifications for each item of test equipment are listed in Table 4-1. Except as detailed, settings of test equipment apply to performance test procedures. All other test equipment operating details are omitted.

As a convenience and to reduce testing time, internal stored settings are provided for many tests. Refer to Section 2.7.8 for stored setting operation. The internal stored settings are listed in Table 4-2.

The Signal Generator should have its top and bottom covers installed for the performance tests. All of the tests can be performed without access to the internal controls. Before applying power to the Signal Generator, see Section 2 for details of electrical installation. The line voltage should be maintained as specified in Section 2.3 throughout the tests. The performance test procedures are begun after a one-hour minimum warmup of the Signal Generator in a +20 to +30° C ambient temperature range.

A copy of the Performance Test Record (PTR) is provided at the end of this section for convenience in recording the performance of the Signal Generator during performance tests. It can be filled out and used as a permanent record for incoming inspection, or it can be used as a guide for routine performance testing. The PTR lists the section, test, and specification limits. All tests refer to this record.

TABLE 4-1. RECOMMENDED TEST EQUIPMENT

INSTRUMENT	CRITICAL REQUIREMENT	RECOMMENDED
(1) Digital Multimeter	Range: to 40 VDC Accuracy: $\pm 0.1\%$	Keithley 179
(2) Distortion Analyzer	Range: 80 Hz to 60 kHz	HP8903A
(3) Frequency Counter	Range: 1 to 2080 MHz	Racal-Dana 9921
(4) Function Generator	Level: 10 Vpp sine wave into 600 ohm load Range: 1 Hz to 60 kHz Distortion: $< 1\%$	Wavetek 270
(5) Power Meter	Range: 1 to 2080 MHz Input Level: -7 to +13 dBm Accuracy: ± 0.05 dBm	HP436A/8482A
(6) Modulation Meter	Range: 1 to 1300 MHz Residual FM: < 50 Hz (RMS) (quiet room) Residual AM: $\pm 0.05\%$ (RMS) (in CW) > 1.3 GHz AM Accuracy: $\pm 2\%$	HP8901A to 1.3 GHz Marconi 2305
(7) Oscilloscope	Range: DC to 2 MHz Sensitivity: 0.2 V/div (AC coupled)	Tektronix 2213
(8) Spectrum Analyzer	Range: 1 to 4160 MHz Display: 1 dB log and 10 dB log	HP8558B/182T & HP8559A/182T
(9) Precision Attenuator Pads	10, 20, 30, 40, and 50 dB	Weinschel 50-10, 50-20, 50-30, 50-40 and 50-50
(10) Wideband Amplifier	Range: 1 to 2080 MHz Gain: > 20 dB Impedance: 50 ohm	Laboratory Quality
(11) Signal Generator	Range: 1 to 2080 MHz	Wavetek 3520
(12) VSWR Bridge	5 to 2000 MHz Directivity: 40 dB Impedance: 50 ohm	Wiltron 60N50
(13) Coaxial Short	Type N female	Wiltron 22NF
(14) Coaxial Termination	Type N male Impedance: 50 ohm SWR: < 1.05	Wiltron 26N50
(15) 50 ohm Load	-----	Wavetek T151
(16) Loop Probe	-----	See Figure 4-5

TABLE 4-2. STORED SETTINGS

Location	Freq. (MHz)	Level (dBm)	Modulation		Rate (kHz)
			Internal (% or kHz)	External (% or kHz)	
401	10.0000	+10	CW	CW	N/A
402	40.0000	+10	CW	CW	N/A
403	500.0000	+10	CW	CW	N/A
404	1000.0000	+10	CW	CW	N/A
405	2000.0000	+10	CW	CW	N/A
406	100.0000	+10	CW	CW	N/A
407	100.0000	+3	CW	CW	N/A
408	100.0000	-7	CW	CW	N/A
409	2000.0000	0	CW	CW	N/A
410	1.0000	+10	CW	CW	N/A
411	1.0000	+3	CW	CW	N/A
412	10.0000	+10	CW	CW	N/A
413	10.0000	+3	CW	CW	N/A
414	1.0000	+10	CW	CW	N/A
415	500.0000	-6	10% AM	CW	1.0
416	1000.0000	-6	10% AM	CW	1.0
417	1300.0000	-6	10% AM	CW	1.0
418	500.0030	+10	CW	CW	N/A
419	1000.0030	+10	CW	CW	N/A
420	1300.0030	+10	CW	CW	N/A
421	500.0000	+2	30% AM	CW	0.4
422	500.0000	+2	30% AM	CW	1.0
423	500.0000	+2	30% AM	CW	10.0
424	500.0000	-3	30% AM	CW	1.0
425	500.0000	-3	90% AM	CW	1.0
426	1000.0000	-3	30% AM	CW	1.0
427	1000.0000	-3	90% AM	CW	1.0
428	2000.0000	-3	30% AM	CW	1.0
429	2000.0000	-3	90% AM	CW	1.0
430	500.0000	+2	CW	50% AM	N/A
431	1000.0000	+2	CW	50% AM	N/A
432	2000.0000	+2	CW	50% AM	N/A
433	500.0000	-6.9	30% AM	CW	1.0
434	500.0000	-6.9	70% AM	CW	1.0
435	500.0000	-6.9	90% AM	CW	1.0
436	1000.0000	-6.9	30% AM	CW	1.0
437	1000.0000	-6.9	70% AM	CW	1.0
438	1000.0000	-6.9	90% AM	CW	1.0
439	1300.0000	-6.9	30% AM	CW	1.0
440	1300.0000	-6.9	70% AM	CW	1.0
441	1300.0000	-6.9	90% AM	CW	1.0
442	500.0000	+10	10 kHz FM	CW	1.0
443	500.0000	+10	90 kHz FM	CW	1.0
444	1000.0000	+10	10 kHz FM	CW	1.0
445	1000.0000	+10	90 kHz FM	CW	1.0
446	2000.0000	+10	10 kHz FM	CW	1.0
447	2000.0000	+10	90 kHz FM	CW	1.0
448	500.0000	+10	CW	100 kHz FM	N/A
449	500.0000	+10	10 kHz FM	CW	1.0

TABLE 4-2. STORED SETTINGS (Con't.)

Location	Freq. (MHz)	Level (dBm)	Modulation		Rate (kHz)
			Internal (% or kHz)	External (% or kHz)	
450	500.0000	+10	100 kHz FM	CW	1.0
451	1.0000	-8	CW	CW	N/A
452	521.0000	-8	CW	CW	N/A
453	1041.0000	-8	CW	CW	N/A
454	500.0000	-107	CW	CW	N/A
455	500.0000	-10	CW	CW	N/A
456	1.0000	+10	CW	CW	N/A
457	500.0000	+10	CW	CW	N/A
601	10.0000	+2	CW	CW	N/A
602	10.0000	+2	50% AM	CW	1.0
603	10.0000	+2	10 kHz FM	CW	1.0
604	10.0000	+2	CW	CW	N/A

NOTE: ALC is enabled for all above stored settings.

4.2 FREQUENCY RANGE AND RESOLUTION TEST

SPECIFICATION	MIN FREQ	MAX FREQ	RESOLUTION
	1 MHz	1040 MHz	100 Hz
	1041 MHz	2080 MHz	200 Hz

METHOD A frequency counter is used to measure frequency range and resolution. Each digit (a total of 121 settings) will be tested.

EQUIPMENT (3)

PROCEDURE

1. Call stored setting 401.
2. Connect the front-panel RF OUT connector to the appropriate input of the frequency counter as indicated in the following table. Use a BNC Tee and a 50 ohm terminator at the 1 Mohm input of the counter.
3. Using the CURSORS, step through each frequency setting and verify that the actual counter frequency increase per step is equal to the allowable increase per step ± 1 count (see following table).

COUNTER INPUT	FREQUENCY SETTINGS	COUNTER RESOLUTION	INCREASE/STEP (± 1 COUNT)
1 Mohm Low Range	010.0000-010.0009	10 Hz	100.0 Hz
1 Mohm Low Range	010.0010-010.0090	100 Hz	1.00 kHz
1 Mohm Low Range	010.0100-010.0900	100 Hz	10.000 kHz
1 Mohm Low Range	010.1000-010.9000	1 kHz	100.0 kHz
1 Mohm Low Range	011.0000-019.0000	1 kHz	1.000 MHz
1 Mohm Low Range	020.0000-090.0000	1 kHz	10.000 MHz
50 ohm High Range	100.0000-900.0000	1 kHz	100.000 MHz
50 ohm High Range	900.0001-900.0009	10 Hz	100.0 Hz
50 ohm High Range	900.0010-900.0090	100 Hz	1.00 kHz
50 ohm High Range	900.0100-900.0900	1 kHz	10 kHz
50 ohm High Range	900.1000-900.9000	1 kHz	100 kHz
50 ohm High Range	901.0000-909.0000	1 kHz	1 MHz
50 ohm High Range	910.0000-1000.0000	1 kHz	10 MHz
50 ohm Range	1000.0000-1900.0000	1 kHz	100 MHz
50 ohm Range	1900.0002-1900.0010	10 Hz	200 Hz
50 ohm Range	1900.0010-1900.0100	100 Hz	1 kHz
50 ohm Range	1900.0100-1900.1000	1 kHz	10 kHz
50 ohm Range	1900.1000-1901.0000	1 kHz	100 kHz
50 ohm Range	1901.0000-1910.0000	1 kHz	100 kHz
50 ohm Range	1910.0000-2080.0000	1 kHz	10 MHz

4. Verify the instrument frequency range by entering the minimum and maximum specified frequencies and noting the frequency counter readings.

5. If both the resolution (step 3) and range (step 4) are correct, place a check mark on the PTR.

4.3 FREQUENCY ACCURACY TEST

SPECIFICATION

All modes (CW, AM, and FM) $\pm 0.001\%$ with ALC on;
($\pm 0.001\% + 10$ kHz) with ALC off

METHOD

A frequency counter is used to measure frequency accuracy. All carrier frequencies are derived from a single crystal-controlled oscillator. The instrument will be tested at one CW frequency to verify that the crystal-controlled oscillator operates within specified limits.

EQUIPMENT

(3)

PROCEDURE

1. Call stored setting 402.
2. Connect the 1 Meg ohm input of the frequency counter to the RF OUT connector using a BNC tee connector and the 50 ohm load.
3. The counter should read between 39,999.60 and 40,000.40 kHz. Record the counter reading to seven places on the PTR.
4. Turn ALC off. The frequency counter should read between 39,989.60 and 40,010.40 kHz. Record the counter reading on the PTR.

4.4 FREQUENCY STABILITY TEST

SPECIFICATION

0.2 ppm/hr with ALC on; With ALC off: 1 to 520.9999 MHz, 500 Hz/10 min; 521 to 1039.9999 MHz, 1000 Hz/10 min; 1040 to 2080 MHz, 2000 Hz/10 min

METHOD

The frequency stability is measured with a frequency counter at the indicated time intervals after a one-hour minimum warmup.

EQUIPMENT

(3)

PROCEDURE

1. Call stored setting 403.
2. Connect the 50 ohm input of the frequency counter to the RF OUT connector.
3. Allow the instrument to warm up for at least 2 hours. After the warm-up record the frequency counter readings to nine places at 15-minute intervals for a one-hour period. The difference between the maximum and minimum readings in the one-hour period should not exceed 100 Hz. Record the difference between the maximum and minimum readings in Hz on the PTR.

4. Press the ALC, 0, and EXEC keys to turn the ALC off. After a one-minute interval, record the frequency counter readings to nine places at five-minute intervals for a ten-minute period. The difference between the maximum and minimum readings in the ten-minute period should not exceed 500 Hz. Record the difference between the maximum and minimum frequency readings in Hz on the PTR.

4.5 OUTPUT LEVEL ACCURACY TESTS

SPECIFICATION

Power Level: + 10 to -137 dBm (0.707 V to 0.03 μ V)

Total Level Accuracy:	+10 to -36.9 dBm	\pm 2.0 dB
	-37 to -46.9 dBm	\pm 2.2 dB
	-47 to -56.9 dBm	\pm 2.4 dB
	-57 to -66.9 dBm	\pm 2.6 dB
	-67 to -76.9 dBm	\pm 2.8 dB
	-77 to -86.9 dBm	\pm 3.0 dB
	-87 to -96.9 dBm	\pm 3.2 dB
	-97 to -106.9 dBm	\pm 3.4 dB
	-107 to -116.9 dBm	\pm 3.6 dB
	-117 to -126.9 dBm	\pm 3.8 dB
	-127 to -137 dBm	\pm 4.0 dB

Accuracy Breakdown: Flatness: (+10 to -6.9 dBm)
 \pm 1.5 dB

Step Atten: \pm 0.6 dB or 2%
of attenuation, whichever
is greater

METHOD

The level accuracy between +10 and -6.9 dBm is the sum of the flatness for the given frequency ranges and the display error. Both errors are measured with a power meter.

The flatness is measured relative to 100 MHz in 1 MHz steps from 1 to 10 MHz and in 10 MHz steps from 10 to 2080 MHz at +10, +2, and -7 dBm output levels.

The level accuracy below -7 dBm depends upon the Step Attenuator error in addition to the flatness.

The Step Attenuator error is measured by an RF substitution method. Each of the four pads (10, 20, 40, and 60 dB) in the Step Attenuator is measured at 2000 MHz. A reference output level is set with a power meter. A reference trace is obtained with a spectrum analyzer and a standard attenuator pad. The standard pad is removed and the Step Attenuator position to be measured is substituted. The spectrum analyzer trace is returned to the reference level by resetting the

output level. The resulting instrument output level is measured and compared to the original power meter reference level. An RF amplifier is required to boost signal levels below the -60 dBm level.

4.5.1 FLATNESS TEST

EQUIPMENT

(5)

PROCEDURE

1. Call stored setting 406.
2. Connect the power sensor to the front-panel RF OUT connector and note the power meter reading.
3. Using the CURSORS, change the instrument RF output frequency in 10 MHz steps between 10 and 2080 MHz and observe the maximum change in the power meter readings from the +10 dBm reading. Repeat this procedure except change the frequency in 1 MHz steps from 1 MHz to 10 MHz. The maximum allowable change is ± 1.5 dB. Record the maximum change on the PTR.
4. Call stored setting 407 and note the power meter reading.
5. Repeat step 3 except observe the maximum change in the power meter readings from the +3.0 dBm reading. Record the maximum change from the +3.0 dBm reading on the PTR.
6. Call stored setting 408 and note the power meter reading.
7. Repeat step 3 except observe the maximum change in the power meter readings from the -7 dBm reading. Record the maximum change from the -7 dBm reading on the PTR.

4.5.2 STEP ATTENUATOR ACCURACY TEST

EQUIPMENT

(5) (8) (9) (10)

PROCEDURE

1. Call stored setting 409.
2. Connect the power sensor to the RF OUT connector and note the power meter reading.
3. Disconnect the power sensor and connect a standard 10 dB attenuator pad to the RF OUT connector. Connect the output of the attenuator pad to the spectrum analyzer as shown in Figure 4-1.

4. Set the spectrum analyzer to 2000 MHz, the bandwidth to 10 kHz, and the frequency span per division to 1 kHz. Set the vertical display to 1 dB per division.

5. Use the analyzer log reference controls to obtain a peak trace one division below the log reference line of the spectrum analyzer display. Center the trace in the display with fine tuning.

6. Enter an amplitude of -10 dBm.

7. Disconnect the 10 dB attenuator pad from the setup and reconnect the spectrum analyzer to the RF OUT connector.

8. Use the CURSOR keys to realign the peak of the trace one division below the log reference line as in step 5.

9. Disconnect the spectrum analyzer from the front-panel RF OUT connector. Connect the power meter and enter an amplitude of 10.0 dB greater than the present setting.

10. Observe the difference between the actual power meter reading and the 0 dBm reference setting in step 2. The difference or error should be ± 0.6 dB maximum. Record the error on the PTR.

11. Repeat steps 1 through 10 using the standard attenuator pads and the instrument output amplitude settings indicated in the following table.

STEP 3 AND 7 ATTENUATOR PAD (dB)	STEP 6 OUTPUT AMPLITUDE (dBm)	STEP 10 ERROR (dB)
20	-20	± 0.6
40	-40	± 0.8
40+20	-60	± 1.2

NOTE: To test the Step Attenuator below -20 dBm, an RF amplifier (>20 dB gain) is required. Insert the amplifier between the standard attenuator pad and the spectrum analyzer. The Step Attenuator can be tested down to -130 dBm if a higher-gain RF amplifier is used and if precautions are taken to properly shield the RF output from the instrument proper.

The test may be repeated at other frequencies if desired.

4.6 HARMONICS TEST

SPECIFICATION

<-26 dBc from 1 to 10 MHz
<-30 dBc from 10 MHz to 1040 MHz
<-25 dBc from 1041 to 2080 MHz

METHOD

A spectrum analyzer is used to measure harmonics in the frequency range of the instrument at +10 and +3 dBm output levels.

NOTE: Use the analyzer reference level control to maintain a constant reference level as the instrument frequency is changed.

EQUIPMENT

(8)

PROCEDURE

1. Call stored setting 410.
2. Connect the spectrum analyzer to the instrument RF OUT connector.
3. Set the spectrum analyzer to measure harmonic distortion for fundamental frequencies below 10 MHz. Set the display to 10 dB/division. Locate the zero reference at the left edge of the graticule and adjust the fundamental amplitude to the log reference line (0 dB) in the display.
4. Using the CURSORS, increase the RF output frequency in 1 MHz steps up to 10 MHz. Record the maximum harmonic level observed (should be <-26 dBc) on the PTR.
5. Call stored setting 411 and repeat steps 3 and 4. Record the maximum harmonic level observed (should be <-26 dBc) on the PTR.
6. Call stored setting 412.
7. Set the spectrum analyzer to measure harmonic distortion for fundamental frequencies between 10 and 1040 MHz.
8. Using the CURSORS, increase the RF output frequency in 10 MHz steps between 10 and 1040 MHz while observing the spectrum analyzer display. Record the maximum harmonic level observed (should be <-30 dBc) on the PTR.
9. Repeat step 7 for frequencies between 1040 and 2080 MHz.
10. Repeat step 8 for frequencies between 1040 and 2080 MHz. Record the maximum harmonic level observed (should be <-25 dBc) on the PTR.

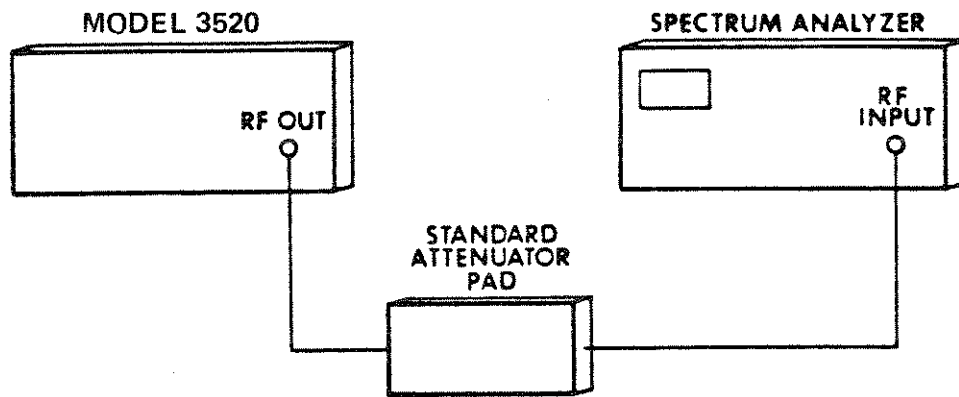

Figure 4-1. Set-up for Step Attenuator Tests

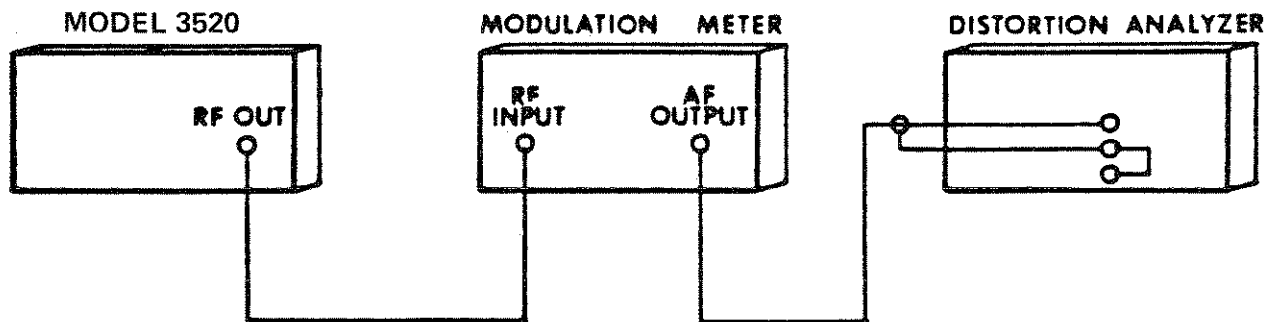

Figure 4-2. Set-up for Distortion Tests

11. Call stored setting 413.

12. Repeat steps 7 and 8, and record the maximum harmonic level observed (should be <-30 dBc) on the PTR.

13. Repeat steps 9 and 10, and record the maximum harmonic level observed (should be <-25 dBc) on the PTR.

4.7 NON-HARMONIC TEST

SPECIFICATION

Fundamental Range (MHz)	Non-harmonic Range (MHz)	Non-harmonic Level (dBc)
1 to 3	1 to 3	<-60
3.0001 to 250	3.0001 to 250	<-65
3.0001 to 350	3.0001 to 350	<-55
3.0001 to 520	3.0001 to 1000	<-35
3.0001 to 2000	3.0001 to 4160	<-30
3.0001 to 2080	3.0001 to 4160	<-25

METHOD

A spectrum analyzer is used to measure the level of nonharmonics in the frequency range of the instrument at the maximum specified output level of +13 dBm.

EQUIPMENT

(8)

PROCEDURE

1. Call stored setting 414.

2. Connect the front-panel RF OUT connector to the RF input of the spectrum analyzer.

3. Set the spectrum analyzer to measure the non-harmonic content of the instrument output between 1 and 3 MHz. Set the bandwidth to 30 kHz, the frequency span per division to 1 MHz, and the display to 10 dB/division. Locate the zero reference at the left edge of the graticule, and adjust the fundamental to the log reference line (0 dB) in the display.

4. Using the CURSORS, increase the RF output frequency in 0.1 MHz steps between 1 and 3 MHz. Record the maximum non-harmonic observed (should be <-60 dBc) on the PTR.

5. Set the spectrum analyzer to measure the non-harmonic content of the instrument output between 3 and 1000 MHz. Set the bandwidth to 300 kHz and the frequency span per division to 100 MHz.

6. Using the CURSORS, increase the RF output frequency in 1 MHz steps between 3 and 10 MHz, and in 10 MHz steps between 10 and 1000 MHz while observing the spectrum analyzer display. Using the table below, record the maximum nonharmonic level observed in each range on the PTR.

FUNDAMENTAL RANGE (MHz)	NON-HARMONIC RANGE (MHz)	NON-HARMONIC LEVEL (dBc)
3.0001-250	3-250	<-65
3.0001-350	3-350	<-55
3.0001-1000	3-1000	<-35
3.0001-2000	3-4160	<-30
3.0001-2080	3-4160	<-25

4.8 RESIDUAL AM TEST

SPECIFICATION

<-60 dBc in a 50 Hz to 15 kHz post-detection bandwidth.

METHOD

A modulation meter operating in AM mode is used to demodulate the instrument output at the minimum leveler point where AM noise is maximum. A 10 MHz high-pass filter is used to eliminate feedthrough at the modulation meter IF. A distortion analyzer (operating in level mode) is used to increase the resolution of the demodulated output of the modulation meter. The system is calibrated at a 10% AM level. The 10% AM is removed and the residual AM is read in dB below the calibrated 10% AM level. 20 dB is added to the reading to relate the residual AM to the carrier.

EQUIPMENT

(2) (6)

PROCEDURE

1. Call stored setting 415.
2. Connect the equipment as shown in Figure 4-2.
3. Set the modulation meter to read %AM and the filter bandwidth to 50 Hz - 15 kHz. Enable the 10 MHz high-pass filter by using special function 3.4.
4. Use the CURSOR keys to produce a modulation meter reading of 10% AM.
5. With the distortion analyzer operating in AC Volts mode, calibrate it for a 0 dB meter reading. The system is now calibrated at a reference level of -20 dBc. Since the modulating signal and carrier amplitudes are equal at 100% AM, it follows that at 10% AM the modulating signal is -20 dBc.
6. Press the MODULATION CW and EXEC keys.

7. Without disturbing the instrument or modulation meter controls, read the residual AM below the 0 dB reference level in step 5, then add 20 dB to the above reading to obtain the residual AM below the carrier. (For example, a 48 dB residual AM below the 0 dB reference +20 dB = 68 dB residual AM below the carrier.) The residual AM should be <-60 dBc. Record the residual AM in dBc on the PTR.

8. Call stored setting 416 and repeat steps 3 through 7 for a carrier frequency of 1000 MHz.

9. Call stored setting 417 and repeat steps 3 through 7 for 2000 MHz carrier.

Other frequencies may be tested as desired.

4.9 RESIDUAL FM TEST

SPECIFICATION

1 to 520.9999 MHz: <200 Hz in a 50 Hz to 15 kHz post-detection bandwidth
521-1040.9999 MHz: <400 Hz in a 50 Hz to 15 kHz post-detection bandwidth
1041-2080 MHz: <800 Hz in a 50 Hz to 15 kHz post-detection bandwidth.

METHOD

A modulation meter is used to measure residual FM. The instrument is operated in FM mode where the residual FM is greatest.

The residual FM is measured in an environment where the noise level is <60 dB relative to 2×10^{-4} μ bar.

EQUIPMENT

(6)

PROCEDURE

1. Call stored setting 418.
2. Connect the front-panel RF OUT connector to the 50 ohm RF input of the modulation meter.
3. Set the modulation meter to read FM deviation at 500 MHz and the filter bandwidth to 50 Hz - 15 kHz.
4. Measure the average level of the FM deviation on the modulation meter (disregard occasional peaks). The residual FM should be <200 Hz. Read the residual FM on the modulation meter with the function switch set to +FM and the -FM positions. Record the average of the two readings in Hz on the PTR.

5. Call stored setting 419 and repeat steps 3 and 4. The residual FM should be <400 Hz.

6. Call stored setting 420 and repeat steps 3 and 4. Residual FM should be <800 Hz.

4.10 INTERNAL MODULATION FREQUENCY ACCURACY TEST

SPECIFICATION $\pm(2\% + 6 \text{ Hz})$

METHOD A frequency counter and the output from the modulation meter are used to measure modulation frequency. Since the same oscillator is used for both the AM and FM modes, one test will suffice for both modes.

EQUIPMENT (3) (6)

PROCEDURE

1. Call stored setting 421.
2. Connect the low frequency input of the frequency counter to the modulation meter output. The counter should read between 386 and 414 Hz. Record the counter reading on the PTR.
3. Call stored setting 422. The counter should read between 974 and 1026 Hz. Record the counter reading on the PTR.
4. Call stored setting 423. The counter should read between 9,794 and 10,206 Hz. Record the counter reading on the PTR.

4.11 PERCENT AM ACCURACY TEST

SPECIFICATION $\pm 6\%$ at a frequency of 1 kHz. NOTE: This specification applies at an output of $\leq +2$ dBm. AM is possible above +2 dBm if the peak of the modulated output does not exceed +10 dBm.

METHOD The %AM accuracy is measured with a modulation meter.

EQUIPMENT (6)

PROCEDURE

1. Call stored setting 424.
2. Connect the modulation meter input to the instrument RF OUT connector. Set the modulation meter to read +AM and the filter to 200 kHz.
3. Note the modulation meter reading in %AM. Set the modulation meter to -AM, and note the modulation meter %AM reading as before. Compute the average of the two readings. The average %AM should be between 28.2 and 31.8%. Record the average %AM on the PTR.

4. Call stored setting 425 and repeat step 3. The average %AM should be between 84.6 and 95.4%.
5. Call stored setting 426 and repeat step 3. The average %AM should be between 28.2 and 31.8%.
6. Call stored setting 427 and repeat step 3. The average %AM should be between 84.6 and 95.4%.
7. Call stored setting 428 and repeat step 3. The average %AM should be between 28.2 and 31.8%.
8. Call stored setting 429 and repeat step 3. The average %AM should be between 84.6 and 95.4%.

Other modulation depths may be tested as desired.

4.12 AM BANDWIDTH TEST

SPECIFICATION

100 Hz to 30 kHz (3 dB bandwidth) with ALC on.
DC to 30 kHz (3 dB bandwidth) with ALC off.
Input level required for calibrated display: 10 Vpp into 600 ohms with ALC off; 0.25 to 1 Vpp into 600 ohms with ALC on.

METHOD

The measurement is made with a modulation meter operating in AM mode and a function generator. The function generator supplies an external sine wave to amplitude-modulate the instrument. At approximately 50% AM, the modulation meter is set to relative dB mode. The external modulation frequency is increased from 1 kHz to 30 kHz and the AM bandwidth is measured as the change in dB level from the 0 dB reference level.

EQUIPMENT

(2) (6)

PROCEDURE

1. Call stored setting 430.
2. Connect the equipment as shown in Figure 4-3.
3. Set the modulation meter to read +AM and turn off all filters.
4. Set the function generator for a 1 kHz sine wave output and the attenuator controls for an approximately 0.5 Vpp sine wave on the oscilloscope.
5. Set the modulation meter to the Relative dB mode.
6. Maintain the 0.5 Vpp external input level and slowly decrease the function generator frequency from 1 to 0.1 kHz, then slowly increase the function generator frequency to 30 kHz. Observe the modulation meter. It should read between +3 and -3 dB. Note the change in dB from the 0 dB calibration level.

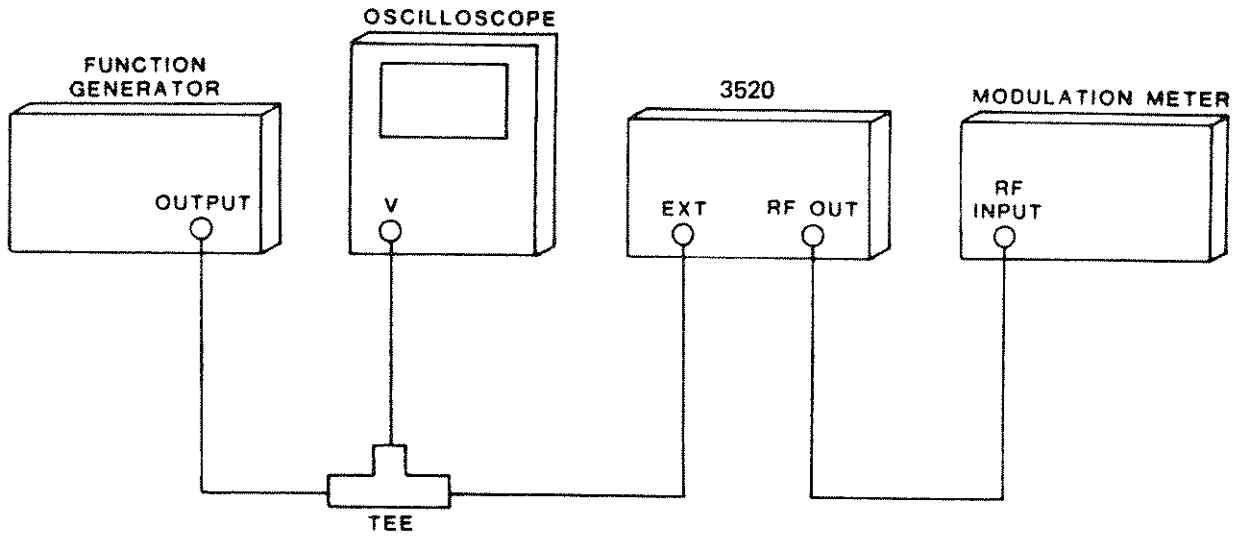

Figure 4-3. Setup for AM and FM Bandwidth

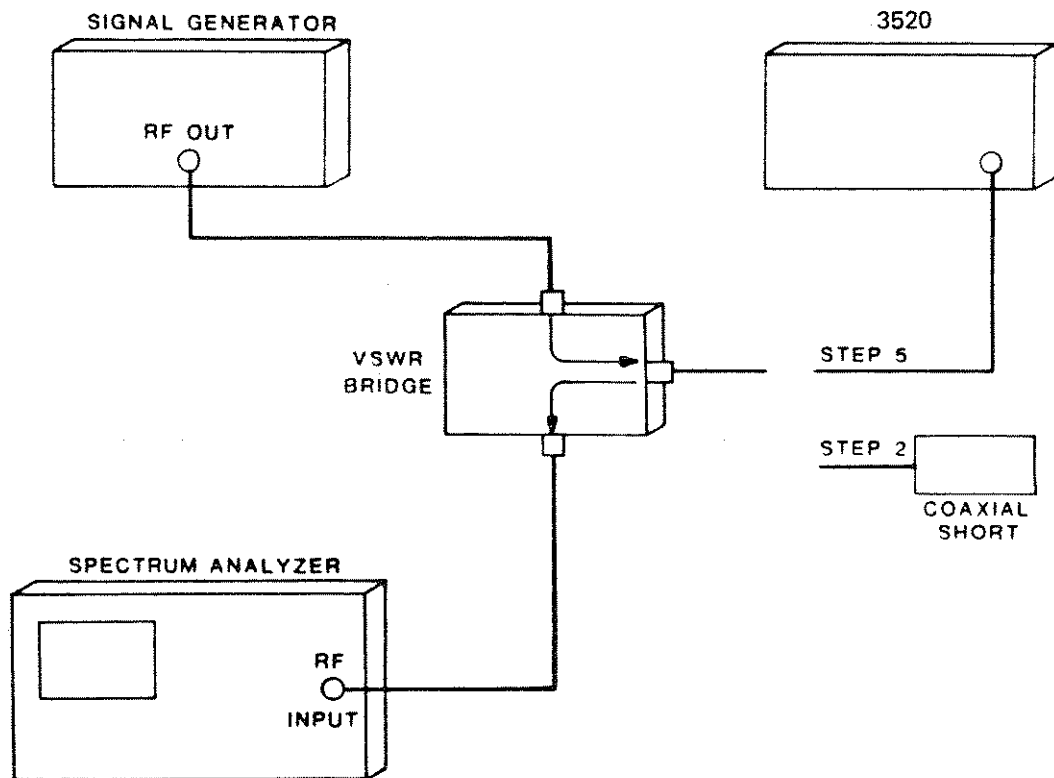

Figure 4-4. Setup for Impedance Test

7. Repeat steps 5 and 6 with the modulation meter set to -AM. Note the change in dB from the 0 dB calibration level.
8. Record the larger of the two dB changes obtained in steps 6 and 7 on the PTR.
9. Turn the ALC off and set the function generator controls for a 10 Vpp sine wave on the oscilloscope.
10. Use the CURSORS to produce a modulation meter reading of 0 dB (approximately 50% AM).
11. Maintain the 10 Vpp external input level and slowly decrease the function generator frequency from 1 kHz to 20 Hz, then slowly increase the function generator frequency to 30 kHz. Observe the modulation meter. It should read between +3 and -3 dB. Note the change in dB from the 0 dB calibration level.
12. Repeat steps 10 and 11 with the modulation meter function switch set to -AM. Note the change in dB from the 0 dB calibration level.
13. Record the larger of the two dB changes obtained in steps 11 and 12 on the PTR.
14. Call stored setting 431 and repeat steps 3 through 13 for a carrier frequency of 1000 MHz.
15. Call stored setting 432 and repeat at 2 GHz.

4.13 AM DISTORTION TEST

SPECIFICATION

<1.5% distortion to 30% AM; <3% distortion to 70% AM; <5% distortion to 90% AM (at a frequency of 1 kHz).

NOTE: This specification applies for an output level of $\leq +2$ dBm. AM is possible above +2 dBm if the peak of the modulated output does not exceed +10 dBm.

METHOD

The measurement is made with a modulation meter and a distortion analyzer which measures the distortion of the demodulated AM from the modulation meter.

EQUIPMENT

(2) (6)

PROCEDURE

1. Call stored setting 433.
2. Connect the equipment as shown in Figure 4-2.

3. Set the modulation meter to read +AM and the filter bandwidth to 50 Hz to 15 kHz.
4. Set the modulation meter to -AM, and observe the modulation meter reading. Use the CURSORS until the average of the modulation meter readings in +AM and -AM is equal to 30% AM.
5. Measure the distortion. It should be less than 1.5%. Record the distortion on the PTR.
6. Call stored setting 434.
7. Use the CURSORS until the average of the modulation meter readings in the +AM and -AM positions of the function switch is equal to 70% AM.
8. Measure the distortion. It should be less than 3%. Record the distortion on the PTR.
9. Call stored setting 435.
10. Use the CURSORS until the average of the modulation meter readings in the +AM and -AM positions of the function switch is equal to 90% AM.
11. Measure the distortion. It should be less than 5%. Record the distortion on the PTR.
12. Use the procedure in steps 1 to 11 to measure and record the % distortion, except call the following stored settings: 436, 437, 438, 439, 440, and 441.

4.14 FM DEVIATION TEST

SPECIFICATION

±5% at 1 kHz modulation frequency.

METHOD

The FM deviation is measured with a modulation meter.

EQUIPMENT

(6)

PROCEDURE

1. Call stored setting 442.
2. Connect the input of the modulation meter to the instrument RF OUT connector.
3. Set the modulation meter to read FM deviation and the filter to 50 Hz - 15 kHz.
4. The modulation meter should read an actual deviation of between 9500 and 10500 Hz. Record the modulation meter reading on the PTR.

5. Call stored setting 443.

6. The modulation meter should read an actual deviation of between 85,500 and 94,500 Hz. Record the modulation meter reading on the PTR.

7. Repeat step 4 using stored setting 444.

8. Repeat steps 5 and 6 using stored setting 445.

9. Repeat step 4 using stored setting 446.

10. Repeat steps 5 and 6 using stored setting 447.

Other deviations may be tested as desired.

4.15 FM BANDWIDTH TEST

SPECIFICATION

100 Hz to 60 kHz (1 dB bandwidth) with ALC on;

DC to 60 kHz (1 dB bandwidth) with ALC off.

Input level required for calibrated display: 10 Vpp into 600 ohms with ALC off; 0.1 to 1 Vpp into 600 ohms with ALC on.

METHOD

The measurement is made with a modulation meter and a function generator. The function generator supplies an external sine wave to frequency modulate the output signal. The system is calibrated with a 1 kHz sine wave at 100 kHz deviation, and modulation meter then set to relative dB. The external modulation frequency is varied from 1 kHz to 100 Hz, and from 1 kHz to 60 kHz, and the FM bandwidth is measured as the change in dB level from the calibrated level.

EQUIPMENT

(4) (6) (7)

PROCEDURE

1. Call stored setting 448.

2. Connect the equipment as shown in Figure 4-3.

3. Set the modulation meter to read +FM and turn off all filters.

4. Set the function generator for a 1 kHz sine wave output and the attenuator controls for an approximately 0.5 Vpp sine wave on the oscilloscope.

5. Set the modulation meter to the Relative dB mode.

6. Maintain the 0.5 Vpp external input level and slowly decrease the function generator frequency from 1 kHz to 100 Hz, then slowly increase the frequency to 60 kHz while observing the modulation meter. It should read between +1 and -1 dB. Note the maximum change from the 0 dB reference to the nearest 0.1 dB.

7. Repeat steps 5 and 6 with the modulation meter function switch set to -FM. Note the change from the 0 dB reference as in step 6. Record the larger of the two changes in dB (in this step and in step 6) on the PTR.

8. Turn the ALC off and set the function generator controls for a 10 Vpp sine wave on the oscilloscope.

9. Set the modulation meter to +FM.

10. Maintain the 10 Vpp external input level and slowly decrease the function generator frequency from 1 kHz to 20 Hz, then slowly increase the frequency to 60 kHz while observing the modulation meter. It should read between +1 and -1 dB. Note the maximum change from the 0 dB reference to the nearest 0.1 dB.

11. Repeat steps 9 and 10 with the modulation meter set to -FM. Note the change from the 0 dB reference as in step 6. Record the larger of the two changes in dB (in this step and in step 10) on the PTR.

4.16 FM DISTORTION TEST

SPECIFICATION

<2% (10 to 100 kHz deviation) at a frequency of 1 kHz.

<4% (3 to 10 kHz deviation) at a frequency of 1 kHz.

METHOD

The measurement is made with a modulation meter and a distortion analyzer, which measures the distortion of the demodulated FM from the modulation meter. Distortion below 3 kHz deviation increases because of residual FM noise. The distortion at 3 kHz deviation is measured in an environment where the noise level is <60 dB relative to 2×10^{-4} μ bar.

EQUIPMENT

(2) (6)

PROCEDURE

1. Call stored setting 449.

2. Connect the equipment as shown in Figure 4-2.

3. Set the modulation meter to read +FM deviation and the filter bandwidth to 50 Hz - 15 kHz. The modulation meter should read approximately 10 kHz.

4. Calibrate the distortion analyzer and measure distortion. The distortion should be less than 4%. Record the distortion on the PTR.

5. Repeat steps 3 and 4 with FM deviation set to 3 kHz, and record the distortion on the PTR.

6. Call stored setting 450. Calibrate the distortion analyzer and measure distortion. The distortion should be less than 2%. Record the distortion on the PTR.

7. Repeat step 6 for FM deviation set to 11 kHz. Record the distortion on the PTR.

4.17 IMPEDANCE TEST

SPECIFICATION

50 ohm; VSWR <1.3 at RF output levels <0.1 VRMS.

METHOD

The measurement is made with a VSWR bridge, and the return loss is displayed on a spectrum analyzer. An RF signal from a signal generator is fed to the input of the bridge. A reference level is established by shorting the bridge output port. The short is replaced by the RF impedance of the instrument. The signal generator is tuned from 1 to 2080 MHz, and the return loss versus frequency is displayed. The frequency of the test generator must be in the same "band" (i.e. 1-520, 521-1040 or 1041-2080 MHz) as the Model 3520 output frequency.

EQUIPMENT

(8) (11) (12) (13)

PROCEDURE

1. Connect the equipment as shown in Figure 4-4. Connect the signal generator to the input port, the spectrum analyzer to the reflected output port, and the coaxial short to the device-under-test port of the VSWR bridge.

2. Set the signal generator output level to -10 dBm, the mode to CW and the frequency to 250 MHz.

3. Set the spectrum analyzer to span the appropriate range (1 to 520, 521 to 1040, or 1041 to 2080 MHz) and the bandwidth to 300 kHz. Use the log reference level controls to calibrate the 250 MHz signal at the top line (0 dB reference) of the display graticule.

4. Disconnect the coaxial short and connect the device-under-test port of the VSWR bridge to the front-panel RF OUT connector. Call stored setting 451 and use the CURSORS to tune from 1 to 520 MHz. Verify that the signal level on the display is >17 dB below the 0 dB reference. Record the reading in dB below the reference on the PTR.

5. Disconnect the VSWR bridge from the RF OUT connector and reconnect the coaxial short to the VSWR bridge device under test port. Set the signal generator output frequency to 750 MHz and use the analyzer log reference controls to calibrate the 750 MHz signal at the top line (0 dB reference) of the display graticule.

6. Disconnect the coaxial short and connect the device-under-test port of the VSWR bridge to the front-panel RF OUT connector. Call stored setting 452 and use the CURSORS to tune from 521 to 1040 MHz. Verify that the signal level on the display is >17 dB below the 0 dB reference. Record the reading in dB below the reference on the PTR.

7. Call stored setting 453 and repeat the above procedure for 1041 to 2080 MHz with the signal generator set to 1500 MHz. Record the reading on the PTR.

4.18 RFI TEST

SPECIFICATION

<1.0 μ V is induced in a two-turn, one-inch diameter loop which is held one inch away from any surface (loop feeds a 50 ohm receiver) at 500 MHz.

METHOD

A 50 ohm receiver consisting of a 26 dB amplifier and a spectrum analyzer are calibrated at a 1 μ V level using the instrument. A loop probe is then connected to the receiver and the leakage is measured at a one-inch distance from the external surfaces of the instrument with the RF OUT connector terminated in 50 ohms. Figure 4-5 describes the loop probe. A screen room may be required for this measurement.

EQUIPMENT

(8) (10) (14) (15) (16)

PROCEDURE

1. Call stored setting 454. Set frequency to 500 MHz.
2. Connect the equipment as shown in Figure 4-6.
3. Set the spectrum analyzer bandwidth to 100 kHz, the scan width to 0.5 MHz/div, the video filter to 100 Hz, the input attenuation to 0 dB, and the log reference level to -50 dBm with a 10 dB/division vertical scale. Center the signal on the display using the center frequency control. Calibrate the analyzer for the -107 dBm signal at the -30 dB graticule using the log reference controls.

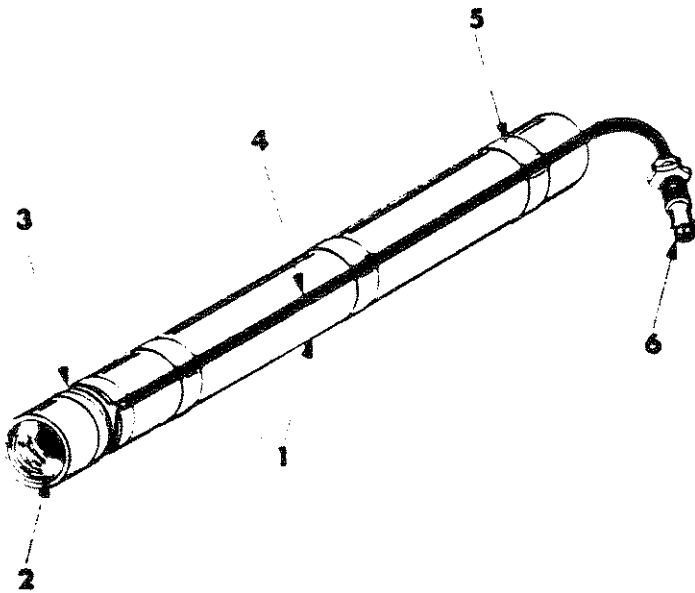

1. Rexolite Rod: 1.25 in. dia. by 11 in.
2. Hole: 1.00 in dia. by 0.80 in. deep.
3. Groove: 0.120 in wide by 0.125 in deep 1.00 in from end of rod.
4. Coaxial Cable: (RG-174/U) 0.110" diameter by 19" long. Strip shield for 7 in, and cut off shield to $\frac{1}{4}$ in length. Strip insulation from center conductor $\frac{1}{4}$ in. Wind 2 turns of insulated center conductor in groove of rod. Solder shield to center conductor, and insulate the solder joint.
5. Wind mylar tape around the two-turn loop, and around the rod (three places).
6. BNC male connector.

Figure 4-5. Loop Probe

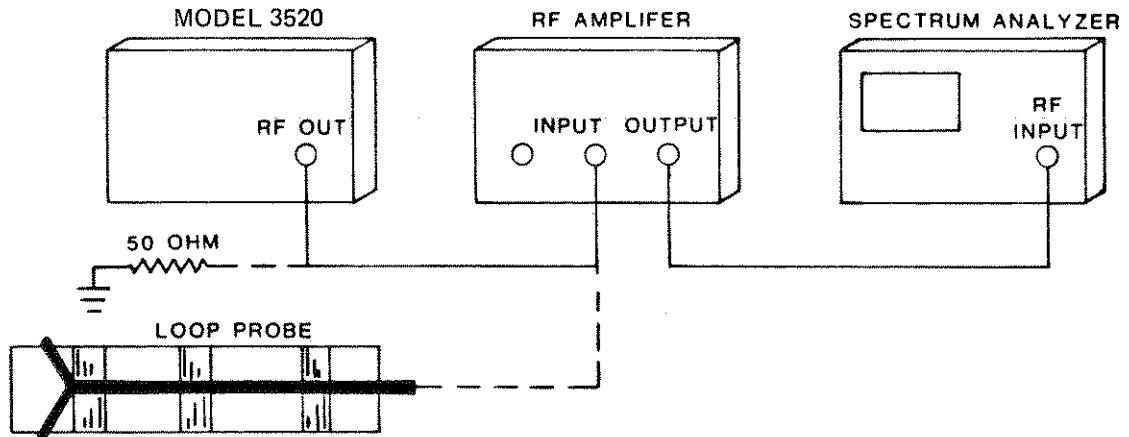

Figure 4-6. Setup for RFI Test

4. Disconnect the RF amplifier from the instrument and connect the 50 ohm coaxial termination to the instrument RF OUT connector. Tighten the termination to minimize RF leakage.

5. Call stored setting 455. Set frequency to 500 MHz.

6. Connect the loop probe to the input of the RF amplifier. Move the loop probe over the surfaces of the instrument with the two-turn loop at a one-inch distance. The signal plus noise should be less than the -107 dBm reference. Record the maximum reading in dBm on the PTR.

4.19 REVERSE POWER PROTECTION CHECK

The following procedure is recommended to ensure proper operation of the protection circuit.

1. Call stored setting 456 and connect a 50 ohm detector to the RF OUT connector.

2. Monitor the DC output of the detector on a suitable oscilloscope.

3. The Reverse Power Protection circuit is checked by pressing the OUT RST, 0, and EXEC keys. This lowers the trip level of the circuit, thus causing the circuit breaker to open and latch, the CB TRIPPED error message to appear on the LEVEL display, and the detected output displayed on the oscilloscope to go to zero. The circuit breaker can then be reset by pressing the OUT RST, 1, and EXEC keys.

4. Call stored setting 457 and repeat the check.

NOTE

The above procedure, while not a complete performance check, is considered adequate for most applications. Also, if available, a high-power RF signal source, set for an output of slightly greater than 0.7 W, can be used to verify circuit breaker operation.

Other frequencies can be checked but it should be noted that this test is valid only with a generator output of +10 dBm and Freq less than 700 MHz. If the circuit is operating properly, place a check mark on the PTR.

SEC	TEST	MINIMUM SPEC	MEASUREMENT	MAXIMUM SPEC
4.2	FREQ RANGE/RES		() CHECK	
4.3	FREQ ACCURACY	39,999.60 kHz	kHz	40,000.40 kHz
		39,989.60 kHz	kHz	40,010.40 kHz
4.4	FREQ STABILITY		Hz	100 Hz
			Hz	500 Hz
4.5.1	FLATNESS	-1.5 dB	dB	+1.5 dB
		-1.5 dB	dB	+1.5 dB
		-1.5 dB	dB	+1.5 dB
4.5.2	STEP ATT ACCURACY	-0.6 dB	dB	+0.6 dB
		-0.6 dB	dB	+0.6 dB
		-0.8 dB	dB	+0.8 dB
		-1.2 dB	dB	+1.2 dB
4.6	HARMONICS		dBc	-26 dBc
			dBc	-26 dBc
			dBc	-30 dBc
			dBc	-25 dBc
			dBc	-30 dBc
			dBc	-25 dBc
4.7	NON-HARMONICS		dBc	-60 dBc
			dBc	-65 dBc
			dBc	-55 dBc
			dBc	-35 dBc
			dBc	-30 dBc
			dBc	-30 dBc
			dBc	-25 dBc
4.8	RESIDUAL AM		dBc	-60 dBc
			dBc	-60 dBc
			dBc	-60 dBc

SEC	TEST	MINIMUM SPEC	MEASUREMENT	MAXIMUM SPEC
4.9	RESIDUAL FM		Hz	200 Hz
			Hz	400 Hz
			Hz	800 Hz
4.10	INT MOD FREQ ACC	386 Hz	Hz	414 Hz
		974 Hz	Hz	1026 Hz
		9794 Hz	Hz	10206 Hz
4.11	% AM ACCURACY	28.2%	%	31.8%
		84.6%	%	95.4%
		28.2%	%	31.8%
		84.6%	%	95.4%
		28.2%	%	31.8%
		84.6%	%	95.4%
4.12	AM BANDWIDTH	-3 dB	dB	+3 dB
		-3 dB	dB	+3 dB
		-3 dB	dB	+3 dB
		-3 dB	dB	+3 dB
		-3 dB	dB	+3 dB
		-3 dB	dB	+3 dB
4.13	AM DISTORTION		%	1.5%
			%	3%
			%	5%
			%	1.5%
			%	3%
			%	5%
			%	1.5%
			%	3%
			%	5%

PERFORMANCE TEST RECORD, MODEL 3520 (Cont'd)

S/N _____

DATE _____

SEC	TEST	MINIMUM SPEC	MEASUREMENT	MAXIMUM SPEC
4.14	FM DEV ACCURACY	9,500 Hz	Hz	10,500 Hz
		85,500 Hz	Hz	94,500 Hz
		9,500 Hz	Hz	10,500 Hz
		85,500 Hz	Hz	94,500 Hz
		9,500 Hz	Hz	10,500 Hz
		85,500 Hz	Hz	94,500 Hz
4.15	FM BANDWIDTH	-1.0 dB	dB	+1.0 dB
		-1.0 dB	dB	+1.0 dB
4.16	FM DISTORTION		%	4%
			%	4%
			%	2%
			%	2%
4.17	IMPEDANCE		dBc	-17 dBc
			dBc	-17 dBc
			dBc	-17 dBc
4.18	RFI		dBm	-107 dBm
4.19	REV PWR PROT		()	CHECK

The UP DOWN PARAMETER EXERCISE using the HP9825 is a third version of this program. The program has fewer lines because some of the instructions were omitted, and fewer blank spaces were entered. The operation is very similar to the Wavetek 6000 program.

```
0: "UP DOWN PARAMETER EXERCISE using 9825":
1:
2: dim A#[3],B#[10],C#[10],D#[50],S#[10]
3: fxd 4
4:
5: clr 702
6: beep
7:
8: "VARIABLE PARAMETER":
9: ent "Enter PARAMETER to be varied",A#
10: ent "Enter DATA starting point",B#
11: ent "Enter TERMINATOR string",C#
12: ent "Enter data STEP size",S#
13:
14: "FIXED PARAMETER STRING":
15: ent "Enter FIXED parameter string",D#
16: wrt 702,D#
17: wait 1e3
18:
19: dsp "Hold CONTINUE down to TEST )CONT";beep;stp
20: dsp "Release key to STOP )CONTINUE";stp
21: dsp "To END test enter 1e99 )CONTINUE";stp
22: dsp "VARIABLE STRING is displayed";beep;wait 1e3
23:
24: "loop":
25: wrt 702,A#&B#&C#;dsp A#&B#&C#
26: ent "",J;if J>0 or J<0;gsb +3
27: str(val(B#)+val(S#))>B#;gto -2
28:
29: if J=1e99;gto "end"
30: str(J)>S#;0}J
31: ret
32:
33: "end":beep;dsp "END"
34: end
*27060
```

EXTERNAL REFERENCE

GENERAL INFORMATION

Option 5 includes the circuitry necessary to enable the instrument to be driven by an external reference frequency, thus improving the accuracy of the signal generator. The reference input requirements are as follows:

FREQUENCY - 1, 2, 2.5, 5, or 10 MHz

ACCURACY - within 1 ppm of above frequencies.

LEVEL RANGE - 50 mV to 5 V (RMS)

IMPEDANCE - 1 kilohm

INSTALLATION

To add this option to the instrument, first remove top and bottom covers as explained in Section 5.2 of this manual. The module plugs into the open socket adjacent to the M30-1/4 (refer to Figures 5-5 and 5-6). The additional RF cables connect the M39 to the M30-1/4 and the instrument rear panel.

OPERATION

When an external signal is connected to the rear-panel BNC connector, the instrument is ready to use with increased accuracy. The front-panel ACCURACY lights should indicate "EXTERNAL" unless the FREQUENCY VERNIER is out of the CAL position.

THEORY OF OPERATION

The purpose of this circuit is to phase lock the Crystal Reference in the instrument to a higher accuracy reference. The circuit functions include: "phase detection" to

compare the variable frequency to the reference and supply a reference voltage, "harmonic generation" to allow the external reference to be any of several frequencies, "unlock indication" to tell the operator when this loop is unlocked, and "reference monitoring" to disengage this loop from this instrument when the reference input is disconnected.

Refer to Figure 8/5-1 for a block diagram of the circuit.

PHASE DETECTION

The reference (10 MHz) input to the phase detector is supplied from an external source via the harmonic generator. The signal is fed through a pair of inverters to make the signal level more compatible with the phase detector. The variable (10 MHz) signal from the voltage controlled oscillator is fed through inverters for the same reason. The phase detector output is filtered by an integrator circuit and applied to a varactor diode in the oscillator in the Crystal Reference module. The 40 MHz oscillator frequency is divided by four and fed to the phase detector. A certain voltage to the VCO will tune the variable input to the phase detector to the exact frequency of the reference input. If the variable input frequency shifts high or low, the phase detector output voltage changes and tunes the varactor oscillator in the opposite direction, thus keeping the variable input locked to the reference input.

UNLOCK INDICATION

The integrator output (phase detection circuit) is fed to a window detector. When this tuning voltage goes outside the normal operating range (too positive or negative), a DC voltage is applied to both an LED on top of the module and to the flasher circuitry in the Modulation Board assembly to cause the front-panel ACCURACY light to flash.

HARMONIC GENERATION

The external reference is fed into a circuit which generates harmonics. The output is fed to a 10 MHz filter to eliminate undesired harmonics. This signal is then fed to an amplifier with automatic gain control.

The AGC circuit includes a detector and a comparator. The detector produces a DC level proportional to the RF signal level. This is then "compared" to a DC reference. The comparator output is applied to the AGC input of the amplifier to complete the AGC loop. If the amplifier output level starts to change (increase, for example), the detector output changes (goes more positive) and the comparator output changes the voltage (more negative) on the AGC input to the amplifier. The gain of the amplifier is thus changed (decreased), and the output returns (decreases) to its original level.

REFERENCE MONITOR

This circuit monitors the amplitude of the 10 MHz reference by looking at the detector output in the AGC circuit of the 10 MHz amplifier stage. This level is compared to a fixed DC level. When the reference falls below a level necessary to drive the phase detector, the comparator switches three transistors which eliminate the tuning output to the VCO and also prevent the unlock indicator from being activated.

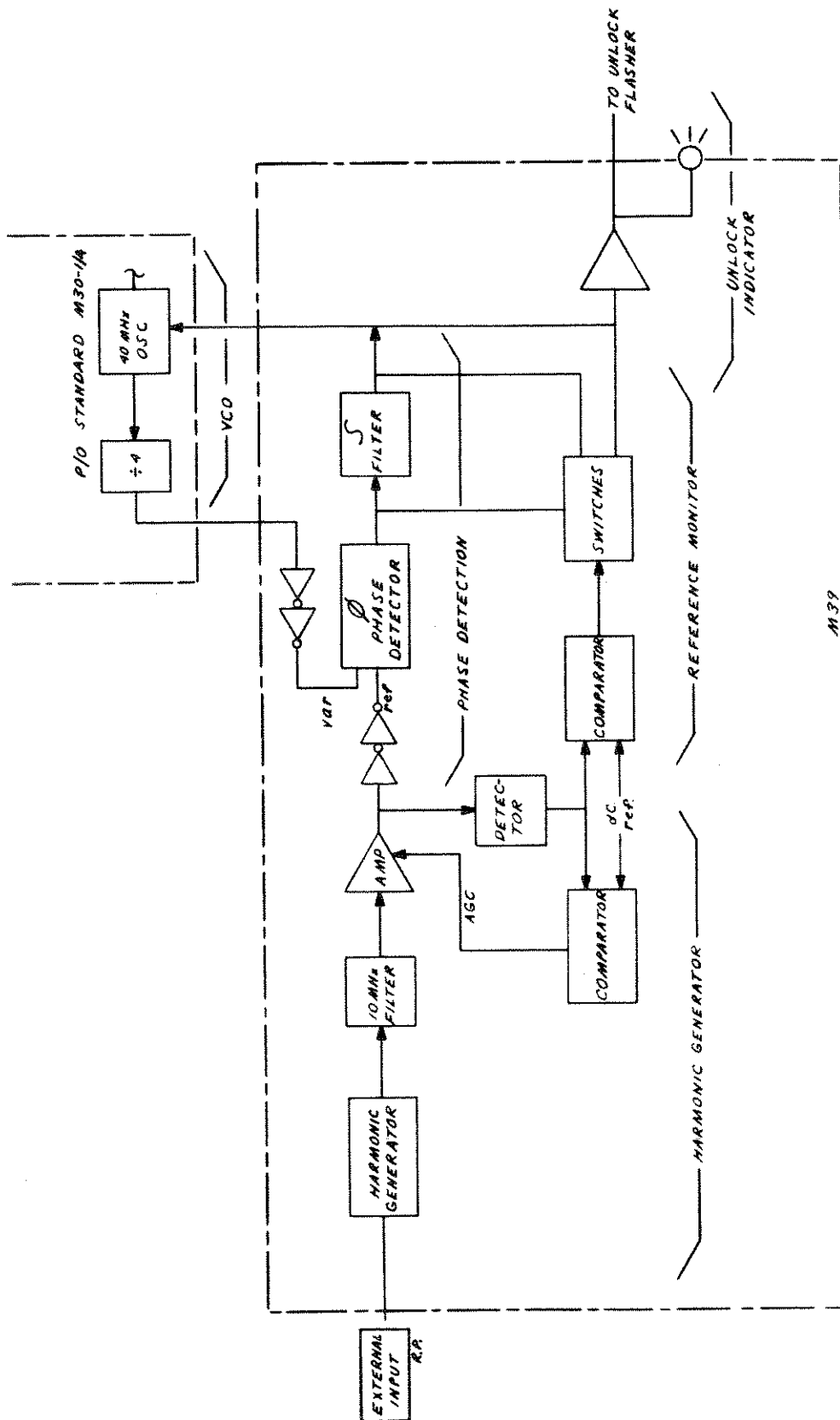

Figure 8/5-1. Block Diagram

HIGH-STABILITY REFERENCE

INTRODUCTION

Option 6 provides a high-stability rear-panel output which can be used to drive the rear-panel input of Option 5. This high-stability TTL output can also be used to drive other devices which require a high-stability reference input. Maximum fan-out is four.

SPECIFICATIONS

Output Frequency	5 MHz
Output Level	TTL
Temp Stability (1 hr. warm-up over 10° to 40° C range.	0.05 ppm
Aging	0.005 ppm/day 0.05 ppm/mo. 0.3 ppm/yr.

Typical Overall Accuracy
(within 3 months of calibration) 0.2 ppm

OPERATION

Option 5 (External Reference) is necessary for driving a Wavetek 3000 Series instrument with this High Stability Reference. The instrument Wiring Diagram (Schematic 1) and the instrument Top View (Figure 5-6 shows the incorporation of this option into the unit. The necessary circuitry is housed in the M40 module.

An RF cable takes the High Stability Reference output (5 MHz) to a rear-panel BNC connector. Another cable connects this output to the External Reference input of Option 5, thus referencing the instrument's Crystal Reference to the High Stability Reference.

This manual provides descriptive material and instructions for the installation and operation of the Wavetek Model 3520 Signal Generator.

SPECIAL PRODUCTS MODIFICATION #749

MODEL 3520

This instrument includes Opt. 05 and Opt. 06, which are not normally available on the model 3520.

Information on Opt. 05 and Opt. 06 follows.

INTRODUCTION

This option extends the low-frequency limit from 1 MHz to 1 kHz. It consists of a Down Converter Module M215, a DC-coupled Reverse Power Protection Module M35-8 to replace the standard AC-coupled M35-9, three RF cables, and a software change. The software change is accomplished by replacing IC2, IC3, and IC4 on the RF Microprocessor Card and IC1, IC2, IC3, and IC4 on the I/O Microprocessor Card. The M215 module is installed in the location indicated in Figure 8/8-2. Cable W2 is removed and replaced with cables W2B and W2C. Cable W22 is installed as shown. This cable supplies a 10 MHz TTL signal to the M215 module. A simplified block diagram of the M215 is shown in Figure 8/8-1.

For operation at 1 MHz or higher, the enable line at pin 13 is a "HI" (5 V), and the relay is in the position shown. This allows the RF signal to pass through the module. When an RF output frequency below 1.0 MHz is programmed, the enable line goes "LO" (0 V), and the relay throws to the opposite position. The RF input signal is programmed to a frequency in the range of 10.001 to 10.9999 MHz, and is mixed with the 10 MHz crystal-reference signal. This results in a difference signal of 1 to 999.9 kHz, which is connected through the RF relay in the M215 to the RF attenuator, reverse-power circuit, and finally to the front-panel RF output connector.

See Figure 8/8-2. Control R18 enables the output level of the down-converter signal to be adjusted to the same level as the 1 MHz output signal.

Specifications for the 3520 are listed below.

SPECIFICATIONS

FREQUENCY RANGE	1 kHz to 2080 MHz
HARMONICS	<-35 dBc 1 kHz to 1 MHz

CALIBRATION

Refer to the M215 schematic. The Q11 circuit converts the 10 MHz TTL signal to a +12 dBm signal with harmonics >40 dB down. Calibration is accomplished by removing the shorting plug P2, and connecting J5 to a spectrum analyzer. C25 and C29 are adjusted for maximum output. Reconnect P2.

With no input to either J1 or J2, connect a DC voltmeter to J3, and adjust the BALANCE control R16 to provide 0 VDC at J3.

The module RF OUTPUT LEVEL control R18 is adjusted for a maximum RF output of +13 dBm.

TROUBLESHOOTING

Many troubleshooting problems can be located simply by checking the DC input currents at pins 3 and 4. Currents should be within ~5 mA of the currents shown on the module schematic.

If currents are within limits, the problem can be isolated to the mixer circuit, or the output amplifier, by removing the shorting plug P3, and connecting the filter output to a spectrum analyzer. The output of the filter should be the program frequency at a level of approximately -13 dBm.

OPTION 8 - FIELD INSTALLATION

1. Refer to Section 5.2.1 in the Service Manual, and remove unit top and bottom covers.

CAUTION

Static-sensitive devices are used in this instrument. Use appropriate anti-static procedures. See Section 5.2 in Service Manual.

2. Refer to the top view drawing of unit in Service Manual. Remove the jumper cable connecting the Analog Interface Card (item 8) to the Multi-function card (item 6). Remove the RF Microprocessor Card (item 7) using green card extractors. With attention to the position codes A000, C000, and E000, replace the three 2764-type ROMs labeled "RF" with the new 2764-type ROMs labeled "LOW RF". Re-install the RF Microprocessor Card (item 7), and the jumper cable.

Remove the I/O Microprocessor Card (item 5) using purple card extractors). With attention to the position codes 8000, A000, C000, and E000, replace the four 2764-type ROMs labeled "I/O" with the new 2764-type ROMs labeled "LOW I/O". Re-install the I/O Microprocessor Card (item 5).

3. Refer to Figure 8/8-2, and install module M215 using #6-32 x 5/16" screw.
4. Replace RF Cable W2 with RF Cables W2B and W2C. Install RF Cable W22.
5. Replace M35-9 (item 12) with M35-8 module.
6. Replace covers.
7. Check operation.