

Description and Operating Manual

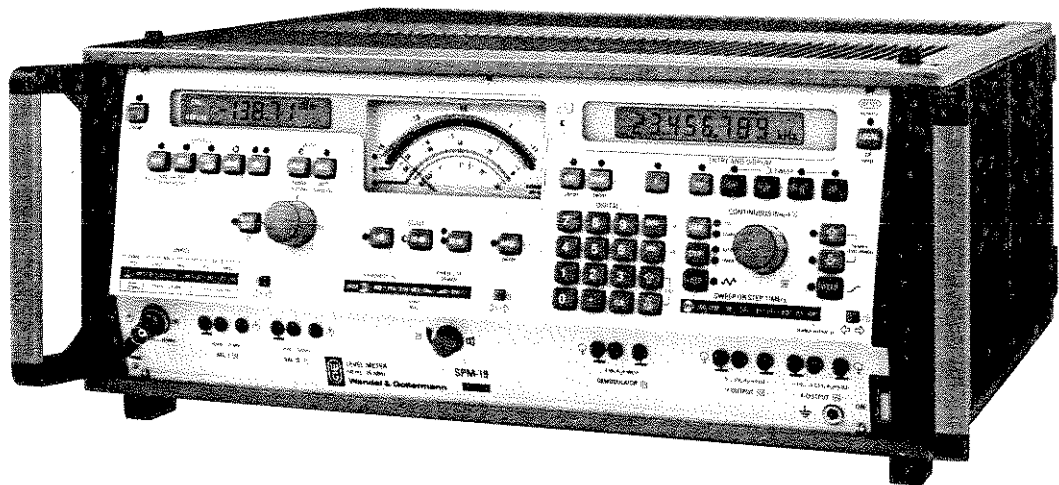

Selective Level Meter

SPM-19

with wideband section
frequency range, 50 Hz to 25 MHz

SUPPLEMENT TO DESCRIPTION AND OPERATING MANUAL
SPM-19, BN 829

Error indication 1-201 or 1-202 after preceding self-test (for Series A ... D)

A subassembly self-test is described in Section 3.5. When a test is acceptable the identification 1----- is shown in the frequency display. In order that an exit from the test program might be executed, the key "MEM" ought to be depressed and the LED is extinguished. However, after that, the above mentioned error indication might appear after the succeeding calibration cycle. But that would be of no significance and could be removed by a press on any key (e.g. frequency f). An additional calibration (depress "CAL" key twice) is recommended.

Short-Form Operating Manual (Series E ...)

The SPM-19 has a Short-Form Operating Manual contained in a drawer at the bottom of the instrument. After the drawer has been pulled out, the single pages of the Operating Manual are accessible. Then the pages may be pushed back into the open drawer, so that a page title can be read while the page is still in the drawer. Then, after the drawer has been closed and again pulled out the single pages are again in the front. Index tabs simplify the manipulation of the pages.

The Short-Form Operating Manual is printed in German (top sides of the pages) and English (bottom sides of the pages). The complete set of cards can be turned-over, whereby a cut-out in the bottom of the drawer eases this operation.

The Short-Form Operating Manual contains, besides the frequency and level settings, specifications about memory functions and error numbers as well as information for the instrument self-test.

When the instrument is used for the first time and with any complicated measuring procedure, the detailed "Description and Operating Manual" ought to be used, so that errors can be avoided during measurements.

LED displays (Series F ...)

The digital displays (identification letters "A" and "D" in Table 4-1) are realized with LED's. All places in the text that give information about "LCD displays" are to be considered as analogous to "LED displays".

Operation of the PSS-19/SPM-19 with 48-kHz-bandwidth

Because of the method used to obtain the 48 kHz bandwidth in the SPM-19 (Sweep Mode and reading summation) the Digital Level Meter reads a value that is always too high by approx. 12 dB.

Level measurements at this bandwidth using the PSS-19/SPM-19 combination are therefore impermissible and have no value.

Power supply from inverters or emergency generator sets

The Level Meter is equipped with a switched mode power supply containing a rectifier circuit which presents a non-linear load to the a.c. line.

Power sources other than the a.c. line (50/60 Hz) can be used if their impedance is low enough and current pulses with an R.M.S. value of 1.5 A and a peak current of 5 A can be delivered.

Setting of automatic measuring range

The setting of the automatic measuring range by means of the "AUTO SET" key as described in para. 4.6.2.1 facilitates the fast setting of the reference level for analog level measurements

at discrete test frequencies. If the SG-4 Display Unit is connected, then manual switching of the measuring range is preferable.

But an SPM-19 of Series K and after has autoranging also.

White noise program (Series K ...)

The "White Noise Program" explained in para. 1.11.2 is already incorporated in all SPM-19 Level Meters except for the Version BN 829/03 commencing with Series K.

Owing to the Option BN 829/00.02 being omitted, the Option "Fixed value memory" BN 829/00.03 for fixed frequencies and permanent setups may be ordered and then retrofitted at the appropriate W&G Service Facility that is responsible for the maintenance.

Automatic frequency stepping (Series K ...)

The "AUTO STEP" function (see para. 4.4.3.2) can be set up to run through any number of sequences when the key sequence MEM 6000 RCL is entered before the "AUTO STEP" key is pressed. An interruption is initiated as follows:

Press the "MAN" key: stop at the last displayed frequency, press the keys " f_{START} " or " f_{STOP} ": stop at the start or stop frequency. Also when the "f" key is pressed the measuring sequence is stopped, however, the function is cancelled.

A handwritten table can be prepared when slow stepping intervals (> 3 seconds) are selected because related values of frequency and level are easily read if, after the frequency change, the measured value is displayed during a dwelltime (level display blanked). This mode may be better used when automatic registration of the result is implemented (printer, x-y recorder, SG-4 Display Unit).

Selective end-to-end measurements with low signal-to-noise ratio (Series K ...)

In Section 4.11 a possibility for selective end-to-end measurements is described. But this method (tracking receiver) functions perfectly only when the received wanted signal-to-noise ratio is sufficiently high. This is usually the case. When measurements are made on very noisy communication paths (e.g. in the high voltage carrier frequency technology) a selective end-to-end measurement in the AUTO STEP mode is possible as follows:

- Set up the same start and stop frequency and also the same step width f_{STEP} and stepping time (1 or 3 s) on both the PS-19 Generator (or PS-16) and the SPM-19 Level Meter. A frequency should be chosen as the start frequency at which a sufficiently high noise ratio is present at the receive side. Can be checked by generator blocking and extinguishing the LED of the signal detector at the SPM-19 = start criterion.
- Set up Generator and Receiver at start frequency
- Switch to the 20 dB scale of the Level Meter and select a measuring range that provides approximately full scale deflection on the analog meter.
- Key in sequence MEM 4000 RCL on the SPM-19 and press the "MEM" key so as to switch out MEMORY again, when fixed frequencies (Memory Auto Step) are not to be operated with.
- Switch in "AUTO STEP" mode on the SPM-19. The flashing LED now shows that the SPM-19 is ready for starting the measuring sequence.
- Release the measuring process by depression of the "AUTO STEP" key at the Level Generator.

Note: A cyclical repetition of the measuring process is possible by additional entry of MEM 6000 RCL (before or after MEM 4000 RCL). The complete measurement including repetition ought not to last longer than about 10 minutes in order that the frequency drift between send and receive side remains the same.



SELECTIVE LEVEL METER

SPM-19

with wideband section
frequency range, 50 Hz to 25 MHz

Description and Operating Manual 829/01, 829/02 C...

I.11.80 0

0.3.6.81 2798 GN v. 2772

Subject to change without notice
Printed in the Federal Republic of Germany

Wandel & Goltermann

PRECISION ELECTRONIC
MEASURING INSTRUMENTS

C O N T E N T S

INTRODUCTION

1

TECHNICAL DATA

1.1	Frequency.....	1-1
1.1.1	Frequency range for selective and wide-band measurements	1-1
1.1.2	Frequency display.....	1-1
1.1.3	Frequency tuning	1-1
1.1.4	Automatic frequency sequences.....	1-2
1.1.4.1	Frequency search.....	1-2
1.1.4.2	Auto step.....	1-2
1.1.4.3	Tracking.....	1-2
1.1.4.4	Sweep frequency operation	1-2
1.1.5	Automatic frequency control (AFC).....	1-3
1.1.6	Error limits of the tuned frequency.....	1-3
1.2	Level.....	1-4
1.2.1	Measured parameters.....	1-4
1.2.2	Result indication, resolution, range selection.....	1-4
1.2.2.1	Result indication.....	1-4
1.2.2.2	Resolution of the digital display.....	1-5
1.2.2.3	Range selection.....	1-5
1.2.3	Measuring ranges.....	1-6
1.2.3.1	Absolute level.....	1-6
1.2.3.2	Reduced level.....	1-6
1.2.3.3	Reduced noise level (dBmOp) and reduced noise power (pWOp).....	1-6
1.2.4	Automatic level calibration.....	1-6
1.2.5	Basic interference.....	1-7
1.2.5.1	Intrinsic noise level.....	1-7
1.2.5.2	Interference level of discrete, non-harmonic signals.....	1-8
1.2.6	High-speed signal detector for rapid signal detection, active only with analog display.....	1-8
1.2.7	Errors of the level indication.....	1-8
1.2.7.1	Error limits in selective mode.....	1-8
1.2.7.2	Total errors.....	1-9
1.2.7.3	Frequency response of the level indication.....	1-10
1.2.7.4	Total error in wide-band mode.....	1-12
1.3	Phase jitter.....	1-12
1.3.1	Measuring range.....	1-12
1.3.2	Error limits of the indication.....	1-12
1.3.3	Output for demodulated phase-jitter signal.....	1-12
1.4	Selectivity and harmonic ratio.....	1-13
1.4.1	Selectivity, switchable.....	1-13
1.4.2	Image frequency and IF suppression.....	1-13
1.4.3	Distortion products.....	1-13
1.4.3.1	Harmonic distortion products.....	1-13
1.4.3.2	Non-harmonic distortion products.....	1-14
1.4.4	Noise power ratio (NPR).....	1-14
1.5	Measurement periods.....	1-14
1.5.1	Level measurements with autoranging calibrator switched off.....	1-14
1.5.2	Level measurement with adjustment of the measuring range.....	1-14
1.5.3	Lengthening of the measurement periods.....	1-15

1.5.4	Phase jitter measurement.....	1-15
1.5.5	Data transfer, transfer time per character.....	1-15
1.6	Inputs.....	1-15
1.6.1	Coaxial input.....	1-15
1.6.2	Balanced input 124/150 Ohms.....	1-15
1.6.3	Balanced input 150/600 Ohms.....	1-16
1.6.4	Maximum permissible input voltage for all inputs.....	1-16
1.7	Additional inputs and outputs.....	1-16
1.7.1	Input for external standard frequency.....	1-16
1.7.2	Output for standard frequency.....	1-16
1.7.3	Output for tuned frequency.....	1-17
1.7.4	IF output.....	1-17
1.7.5	X-output voltage (DC).....	1-17
1.7.6	X-output voltage (DC).....	1-17
1.7.7	Demodulator output.....	1-17
1.7.8	Display unit connection socket.....	1-18
1.7.9	ⓈIEC 625Ⓢ Interface.....	1-18
1.7.10	Digital interface.....	1-18
1.7.11	Power supply connection for Test Probe TK-11.....	1-19
1.7.12	Tracking generator output.....	1-19
1.8	Memories for fixed frequencies and unit settings.....	1-19
1.8.1	Number of fixed frequencies.....	1-19
1.8.2	Number of equipment settings.....	1-19
1.9	Power supplies and ambient conditions.....	1-19
1.9.1	Power supplies.....	1-19
1.9.2	Operating climate.....	1-20
1.10	Dimensions, weight.....	1-20
1.11	Optional accessories.....	1-20
1.11.1	Standard frequency oscillator.....	1-20
1.11.2	White noise program and fixed value memory.....	1-21
1.11.2.1	White noise program without fixed value memory.....	1-21
1.11.3	ⓈIEC 625Ⓢ Interface Bus Board.....	1-21
1.11.4	Printer interface.....	1-21
1.12	Measuring accessories.....	1-21
1.12.1	Test Probe TK-11, active test probe.....	1-21
1.12.2	Test Probe TK-12 with Power Supply Unit TKN-12.....	1-23
1.12.2.1	Test Probe TK-12.....	1-23
1.12.2.2	Power Supply Unit TKN-12.....	1-25
1.12.3	Reflection Factor Measuring Bridge RFZ-14.....	1-25
1.12.4	Adapter FEDA-1.....	1-26
1.12.5	Relay Changeover Switch RU-3.....	1-27
1.13	Ordering information.....	1-29
2	TECHNICAL DETAILS.....	2-1
2.1	Receiver section.....	2-2
2.1.1	Input circuit and frequency conversion.....	2-2
2.1.2	IF amplifier, rectifier, and output circuit.....	2-3
2.1.3	Automatic level calibration.....	2-4
2.1.4	Rapid signal detector.....	2-4
2.1.5	Phase jitter measuring adapter.....	2-5
2.1.6	Test probe connection.....	2-5
2.1.7	Outputs and inputs.....	2-5

2.1.8	Power supply unit.....	2-6
2.1.9	Frequency tuning.....	2-7
2.2	Synthesizer.....	2-7
2.3	Control section with microcomputer.....	2-10
2.4	Printer interface.....	2-11
3	COMMISSIONING.....	3-1
3.1	Unpacking the unit.....	3-1
3.1.1	Notes for shipping.....	3-1
3.1.2.	Transport in the Equipment Case TPK-4 or Transport Case TPG-4.....	3-2
3.1.3	Use in 19" racks.....	3-2
3.2	Installing the unit.....	3-3
3.3	Connection and switching on.....	3-4
3.3.1	Mechanical zero setting.....	3-4
3.4	Power supply unit.....	3-5
3.4.1	Replacing the fuse.....	3-5
3.5	Internal test.....	3-5
3.6	Standard set-up.....	3-6
4	OPERATION.....	4-8
4.1	Controls on the front and rear sides.....	4-8
4.2	Equipment setting after switching on.....	4-9
4.3	Inputs, input impedances, and frequency ranges.....	4-10
4.4	Tuning the receiver frequency.....	4-11
4.4.1	Digital tuning 12	4-11
4.4.2	Continuous frequency tuning MAN	4-12
4.4.3	Frequency tuning in steps.....	4-13
4.4.3.1	Manual stepping.....	4-13
4.4.3.2	Automatic stepping.....	4-14
4.4.4	Transferring the frequency setting to the memories for f _{STEP} and the sweep limits.....	4-15
4.5	Automatic level calibration "AUTO CAL".....	4-16
4.6	Selection of the operating mode analog/digital.....	4-17
4.6.1	Digital level measurement.....	4-18
4.6.1.1	Absolute voltage or power level ABS.....	4-19
4.6.1.2	Level difference.....	4-19
4.6.1.3	Levels reduced to dBm0 values.....	4-20
4.6.2	Analog level measurement.....	4-20
4.6.2.1	Measuring range selection.....	4-21
4.6.2.2	Scale range.....	4-22
4.6.2.3	Rapid signal detector.....	4-23
4.6.3	Direction arrows in the level display.....	4-24
4.6.4	Noise averaging AVRG	4-25
4.7	Bandwidth.....	4-26
4.7.1	Wide-band section.....	4-26
4.7.2	Selective section.....	4-27
4.8	Demodulator.....	4-29

4.9	Phase jitter measurements.....	4-31
4.9.1	Causes and effects of phase jitter.....	4-32
4.9.2	Settings on the level meter.....	4-32
4.10	Automatic frequency control AFC 5	4-34
4.11	Track mode.....	4-35
4.11.1	Applications.....	4-35
4.11.2	Settings on the level meter.....	4-37
4.12	Search.....	4-38
4.12.1	Single search F (Full range).....	4-39
4.12.2	Continuous search OPTimum.....	4-40
4.13	Sweep.....	4-41
4.13.1	Setting up the sweep limits.....	4-42
4.13.2	Sweep sequence and time.....	4-43
4.13.3	Manual sweep.....	4-44
4.13.4	Display unit connection 42	4-44
4.14	DC (Y-) output 24	4-46
4.15	DC (X-) output 25	4-46
4.16	10 kHz IF output 43	4-47
4.17	Remote control of the Level Generators PS-18, PS-19, PSS-19.....	4-47
4.17.1	Tracking generator output.....	4-48
4.18	Standard frequency input 51	4-48
4.19	Digital Interface 40 41	4-48
4.20	Computer control.....	4-49
4.20.1	IEC 625 Interface Bus.....	4-50
4.20.1.1	Interaction between the level meter and the IEEE Bus Interface.....	4-51
4.20.1.2	Structure of the IEC Bus program.....	4-53
4.20.2	Bus specification and bus plugs.....	4-54
4.21	Printer connection.....	4-55
4.22	Memory functions (MEM).....	4-55
4.22.1	Address organization.....	4-56
4.22.2	The functions store and recall.....	4-59
4.22.3	Storing the fixed frequencies.....	4-60
4.22.4	Recalling single fixed frequencies.....	4-60
4.22.5	Recalling a sequence of fixed frequencies.....	4-61
4.22.6	Storage of equipment settings (set-ups).....	4-63
4.22.7	Recall of equipment settings (set-ups).....	4-63
4.23	White noise program and prom.....	4-64
4.23.1	Fixed frequencies and equipment settings.....	4-65
4.23.2	Noise measurements.....	4-68
4.23.2.1	Measurement of the reduced noise level.....	4-69
4.23.2.2	Measurement of the reduced noise power.....	4-71
4.23.2.3	Measurement of the noise power ratio NPR.....	4-72
4.23.3	Limits of noise measurement.....	4-75

4.24	Measuring accessories.....	4-78
4.24.1	Test Probe TK-11.....	4-78
4.24.2	Test Probe TK-12.....	4-79
4.24.3	Adapter FEDA-1.....	4-80
4.24.4	Reflection and signal balance ratio measurements.....	4-81
4.24.4.1	Reflection Loss Measuring Adapter RFZ-14.....	4-81
4.25	Special modes of operation	4-83
4.25.1	Measurements with frequency offset	4-83
4.25.2	Level difference measurement	4-83
4.25.3	Printer mode	4-85
4.25.3.1	Demands placed on the printer	4-85
4.25.3.2	Printout format	4-86
4.25.3.3	Printer release	4-87
4.25.3.4	Operation	4-89
4.25.3.5	Setting the level threshold at the SPM-19	4-89
4.25.3.6	Printout of white noise measurement results	4-91
4.25.3.7	Error annunciation in the printout	4-92
4.25.3.8	Dialog for modifying the printout	4-92
5	MEASURING NOTES.....	5-1
5.1	Selectivity curves of the level meter.....	5-1
5.2	Measurement of high attenuation values.....	5-3
5.3	Pulse noise and interruption measurements.....	5-5
5.4	Psophometric weighting of noise voltages.....	5-6
5.5	Automatic drive level monitoring.....	5-8
6	FUNCTIONAL TESTING, MAINTENANCE, AND MISCELLANEOUS.....	6-1
6.1	Functional test when switching on for the first time....	6-1
6.1.1	Checking the internal noise.....	6-5
6.1.2	Checking the receiver selectivity.....	6-5
6.1.3	Functional test of the test probe connector 18	6-6
6.2	Functional tests of important modules.....	6-6
6.3	Maintenance and miscellaneous.....	6-14
6.3.1	Mechanical construction.....	6-14
6.3.2	Changing or installing the interface boards.....	6-15
6.3.3	Installing the prom.....	6-15
6.3.4	Universal connectors Versacon R 9.....	6-16
6.3.5	Rechargeable batteries for data retention.....	6-17
6.4	Adaption of the V.24-printer interface	6-17
6.4.1	Test of interface, S 1/3	6-17
6.4.2	Automatic printout s 1/1	6-18
6.4.3	Manual printout S 1/2	6-18
6.4.4	Modification of the printout S 1/4, S 1/5	6-18
6.4.5	Paging S 1/8	6-18
6.4.6	Waiting time	6-18
6.4.7	Parity enable S 2/6	6-19
6.4.8	Even parity S 2/7	6-19
6.4.9	Busy polarity S 2/8	6-19
6.4.10	Busy enable S 2/9	6-19
6.4.11	Form feed enable S 2/10	6-20
6.4.12	Baud rate S 3/1 to /3	6-20
6.4.13	Adaption to the basic unit S 3/5 to /8	6-20

Figures

2-1	Simplified block diagram of the Level Meter SPM-19.....	2-1
2-2	Simplified block diagram of the Synthesizer BN 865.....	2-10
2-3	Simplified block diagram of the Printer interface.....	2-12
3-1	Packing notes.....	3-1
3-2	Converting the table-top unit for rack installation.....	3-2
3-3	Rear connections on the SPM-19.....	3-4
4-1	Front view, BN 829/02.....	
4-2	Rear view.....	
4-3	Analog meter of the SPM-19 (Series D...)	4-23
4-4	Direction arrows in the level display.....	4-25
4-5	Dynamic range of the measuring demodulator Relative level -50 to +10 dB.....	4-29
4-6	Receiver tracking.....	4-36
4-7	Configuration and interconnections of the sweep frequency measuring set-up (rear view).....	4-41
4-8	Pin assignments of the display unit connector 42	4-45
4-9	Block diagram of a simple automatic level measuring system.....	4-49
4-10	Block diagram of the IEC-bus interface.....	4-50
4-11	Pin assignments of the bus connector on the level meter	4-54
4-12	Ordering Form No. 5/784 a.....	4-66
4-13	Ordering Form No. 5/784 b.....	4-67
4-14	Noise measurements with the Level Meter SPM-19 in an unused channel of a communications system actually carrying traffic.....	4-68
4-15	NPR value if all telephone channels are uniformly loaded.....	4-73
4-16	Test Probe TK-11.....	4-78
4-17	Measuring at an impedance of 50 Ohms.....	4-80
4-18	Connection of the Measuring Bridge RFZ-14 to the level measuring set-up.....	4-81
4-19	Level Difference Measurement	4-84
4-20	Printout: Level Difference Measurement (Program 5237)	4-90
4-21	Printout: Level Difference Measurement with Tolerance Limits (Program 5277)	4-90
4-22	Printout: Intrinsic NPR of an SPM-19 (Program 5307).....	4-91
4-93	Dialog between printer and interface	4-93
5-1	Typical selectivity curves for the bandwidths 400 Hz, 1.74 kHz, and 3.1 kHz.....	5-1
5-2	Typical selectivity curve of the level meter with bandwidth 25 Hz.....	5-2
5-3	Measurement of high attenuation values.....	5-5
5-4	Psophometric curve.....	5-7
5-5	Selectivity curve and effective noise bandwidth.....	5-7
6-1	Test configuration for the functional test.....	6-1
6-2	Upper side of the upper folding chassis.....	6-14
6-3	Basic socket Versacon [®] 9 with some of the available Versacon [®] 9 adaptors.....	6-16
6-4	V.24 Printer Interface BN 905/01.....	6-21

Tables

4-1	Controls and Sockets on the Front panel.....	4-1
4-2	Controls and Sockets on the Rear.....	4-6
4-3	Address Organization.....	4-57
4-4	Program numbers.....	4-58
4-5	Program numbers for NPR measurement.....	4-80
4-6	Program number structure	4-88
6-1	Sequence of functional test.....	6-2
6-2	Summary of error numbers in the SPM-19.....	6-8

INTRODUCTION

While digital transmission systems are being used more and more at the local and regional levels, FDM systems are still the main systems for long distance traffic. Level measurements play an important part in the measurement and checking of the analog parameters of these systems and the various modules. However, modern test equipment must be available for additional measuring tasks. The selective level meter SPM-19, in which the application of modern circuit technologies and of a microcomputer provide a high degree of accuracy and ease of use, is suitable for these measuring tasks.

The frequency range of the meter extends from 50 Hz to 25 MHz if the coaxial input is used, and the frequency ranges of the balanced inputs extend up to 620 kHz and 14 MHz. The characteristics of the level meter make it equally suitable for development, production, installation, and maintenance of transmission systems with a maximum of 3,600 speech channels, for measurements in the lower multiplex range of single sideband radio link systems, and of single telephone channels. Its remote control facilities also make it suitable for use in automatic measuring systems.

As required by its intended application, the frequency of the SPM-19 can be tuned, over the whole range, either digitally with a keyboard or continuously, and with a resolution of 1 Hz. The frequency can be stepped either manually or automatically in preset steps, for example to step from channel to channel. Up to 100 fixed frequencies can be stored and recalled either sequentially or in any required sequence for frequent measurements

at fixed frequencies. If required, further fixed frequencies can be stored in a customer-specific PROM. Regardless of the type of frequency tuning, the built-in synthesizer provides high stability and accuracy of the selected frequency.

The signal to be measured is either connected to the coaxial input (input impedance 75 Ohm) or to one of the two balanced inputs with frequency ranges of 50 Hz to 620 kHz (150 Ohm, 600 Ohm) and 10 kHz to 14 MHz (124 Ohm, 150 Ohm); each of these inputs can also be switched to high impedance.

For high impedance, low capacitance measurements, the test probe TK-11 or any other suitable test probe can be connected as required. In selective mode, levels between -140 and +22 dB (-130 and +32 dBm) can be measured; in wide-band mode, the limits are -60 and +22 dB (-50 and +32 dBm). The measured level is displayed either digitally with automatic range selection, with a maximum resolution 0.01 dB, or on an analog meter. In the case of analog display, the most suitable scale range of 1 dB, 20 dB or 80 dB can be selected with three pushbuttons for the current measuring task. Range switching is carried out either manually in steps of 1 or 5 dB or automatically after depression of a pushbutton.

In order to obtain the maximum possible measuring accuracy, the microcomputer measures the total input level and adjusts the input attenuator and IF attenuator such that measurements are always carried out with the most favorable settings. It is thus no longer necessary to fit the changeover switch "low noise/low distortion", which has previously caused some confusion.

In addition to measurement of absolute levels, the SPM-19 permits simple measurement of relative levels. For this purpose, a level which was previously measured digitally is transferred to a memory as the reference value and the difference between the measured value and this reference value is displayed digitally or on the analog meter for all subsequent measurements. In the case of measurements in transmission systems, levels are often not specified directly, but with reference to the relative level (dBr) of a test point. In order to simplify evaluation of test results in such cases, the relative level of the test point can be preset in 0.1 dB steps and the result can then be displayed as a reduced level in dB0 (dBm0).

The pushbutton for the relative level is also useable for setting any required reference value (e.g. for frequency response measurements).

Various bandwidths are available for the various measuring tasks. The pilot level, residual carrier signals or frequency spectra are measured with the narrow 25 Hz filter. Sensitive level measurements can be carried out with the 400 Hz bandwidth. A filter with a noise bandwidth of 1.74 kHz can be connected for weighted noise measurements in unused or cleared speech channels at the CF level. A further position of the bandwidth switch permits level measurements with a channel bandwidth of 3.1 kHz. Finally, the noise power of a 48 kHz primary group can be measured.

The built-in demodulator permits demodulation of single sideband signals in the normal or inverted position. The converted signal can either be assessed with the built-in loudspeaker or extracted from the demodulator output for

further external processing. The demodulator is characterized primarily by a very wide dynamic range, which is necessary, for example, for precise measurement of noises or pulse noise in converted speech channels. For assessment of the transmission quality of telephone lines for data transmission, phase jitter measurements can be carried out. The weighting filter and the rectifier characteristic for measurement of the peak to peak value comply with CCITT recommendation 0.91. The phase jitter is displayed either digitally or on a logarithmic scale of the analog meter in the range 0.3 to 30 degrees. An automatic level control, which makes manual calibration superfluous, guarantees high measuring accuracy over the whole frequency range, a considerable reduction in the measuring time, and a high long-term stability. The level meter is thus also suitable for continuous monitoring applications.

In addition to the above mentioned frequency settings, the microcomputer control of the SPM-19 permits various other automatic frequency sequences. The automatic search function, together with the rapid signal detector, is a major aid in searching for interference or excessive levels. The tuning oscillator is tuned until a signal which exceeds a preset level threshold falls within the display range of the analog meter and stops the search. At the same time, an automatic frequency control (AFC) circuit is activated and tunes the oscillator precisely to the frequency of the input signal. The search can be restarted again either manually by depressing a pushbutton or automatically after the level and frequency have been printed out. The search speed is matched to the selected bandwidth. The AFC circuit can also be switched on for normal level measurements with all bandwidths. This circuit

ensures that the oscillator remains correctly tuned over the whole frequency range.

For selective level measurements over a line, for example in channel gaps of the system during normal operation, an electronic circuit which is activated in the mode "track" permits automatic tuning of the level meter to the frequency of a sender with the same frequency steps.

The SPM-19 (BN 829/02) can be extended to form a panoramic receiver by adding a display unit SG-2 or SG-3. Because of the phase continuity during use of the sweep mode, the frequency range can be searched completely in all chosen operating modes, which means that all frequencies present in the band can be clearly identified. The sweep facility fitted in version BN 829/02 is characterised particularly by the fact that the frequency sweep is carried out without phase discontinuities, which means that precise measurements are possible even of objects with extremely steep attenuation edges. The two limit frequencies can be entered via the keyboard to match the application. The signal generators PS-19 and PSS-19 are suitable as signal sources for the sweep measurements.

The combination of PS-19/SPM-19 permits measurements with offset frequencies, e.g. the testing of channel translators. Both types of measurements are possible, either point-by-point or sweep measurements.

Many measuring tasks are particularly simple to solve if the user can store complete equipment settings and recall them when required. Depression of a pushbutton (address selection) causes the unit to set up all previously selected measuring conditions for a specific measuring task. The supply voltage of the memory is buffered by a small battery to maintain the stored data if the main supply fails or is switched off.

All functions of the SPM-19 can be controlled by an external computer which is compatible with the IEC bus via the optionally available interface bus IEC 625 board. The unit can also be connected to an IEEE bus (IEEE Standard 488) with an Adaptor IEC 625/IEEE 488, S 834. With the aid further externally controllable peripheral units such as signal generator, measuring point changeover switch, or external memory systems, powerful automatic level measuring set ups can be constructed for use in test departments or FDM monitoring systems.

The measuring point changeover switch MU-3 with a switching unit MUE-31 and the IEC interface board can be used for automatic testing of FDM modules with 12 channels (channel converters). For measurements at higher frequencies, the measuring point changeover switches MU-4 and MU-7 with interface boards are available. Instead of the interface bus IEC 625 board, a printer interface for V.24/V.28 interface can be fitted for recording the measured results in various print formats.

Due to its excellent NPR value, the SPM-19 is suitable as a selective receiver for measurement of intermodulation and basic noise on FDM cable and radio link systems using the white noise measuring method. An optional white noise program is available to permit measurement of all noise parameters such as reduced noise power (in pWOp), the reduced noise level (in dBmOp), or the noise power ratio NPR (dB).

The test frequencies, in accordance with the recommendations of CCITT/CCIR and INTELSAT, can either be entered via the keyboard or stored in the 100 available fixed frequency positions of the RAM; they can also be stored to customer's specifications in a EPROM. The test modes and test frequencies are recalled from the memories by suitable address selection. The measured values and the corresponding units are shown on the digital result display. The measuring adapters RFZ-5, RFZ-14 (coaxial, above 10 kHz and 100 kHz, respectively) and RFZ-12 (coaxial and balanced up to 4.5 MHz) and SDZ-12 are available as measuring accessories for return loss or unbalance loss measurements. For apparent resistance and return loss matching loss measurements, the Impedance Measuring Attachment SFZ-1 (300 Hz to 612 kHz) is available.

The Relay change-over Switch RU-3 permits digital level difference measurements of higher relative accuracy.

The level meter can be switched from power level calibration (dBm) to voltage level calibration (dB).

In spite of the large number of functions, the SPM-19 is installed in a relatively flat case. The connections, controls, and displays are arranged clearly on an easy to use front panel. LED's above or alongside the pushbuttons signal the selected functions to the user. The unit is available in versions for table-top use or 19" rack mounting.

Front and rear covers are available to protect the SPM-19 against dust and splash water during transport and storage.

The selective level meter SPM-18, which is more simple and has no remote control facilities, operates in the same frequency range as the level meter SPM-19. The following summary shows the test set up structures of the series 18 and 19 and the characteristics of the two level meters.

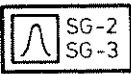
Signal generator	Level meter	Additional units	Characteristics
<div style="border: 1px solid black; padding: 5px; display: inline-block; margin-bottom: 5px;">PS-18</div> (PS-19, PSS-19)	<div style="border: 1px solid black; padding: 5px; display: inline-block;">SPM-18</div>		Selective level meter with manual tuning and frequency search facility. Mains connection; version for additional battery connection through A.C. Inverter WR-450. Option for SPM-18: Phase jitter measuring adapter.
<div style="border: 1px solid black; padding: 5px; display: inline-block; margin-bottom: 5px;">PSS-19</div> (Send section) or <div style="border: 1px solid black; padding: 5px; display: inline-block; margin-top: 10px;">PS-19</div>	<div style="border: 1px solid black; padding: 5px; display: inline-block; margin-top: 10px;">SPM-19</div>	<div style="border: 1px solid black; padding: 5px; display: inline-block; margin-bottom: 10px;">  SG-2 SG-3 Display unit for sweep frequency measurements </div> <div style="border: 1px solid black; padding: 5px; display: inline-block; margin-bottom: 10px; width: 80px; margin-left: auto;">Computer</div> <div style="border: 1px solid black; padding: 5px; display: inline-block; width: 80px; margin-left: auto;">Printer</div> <p style="font-size: small; margin-top: 5px;">Remote control of the test set up via IEC (IEEE) interface</p> <p style="font-size: x-small; margin-top: 5px;">Printout of frequency and level via V.24/V.28 interface</p>	Selective and wide-band level measurements Manual or automatic frequency tuning, frequency search and tracking modes. Microprocessor control unit. Analog and digital level display. Automatic level calibration; phase jitter measurements Memory for 100 fixed frequencies and 11 complete set ups (freely programmable). Version with sweep section (BN 829/02). Remote control of all functions. Options: Interface bus IEC 625 board for remote control. Printer interface for V.24/V.28 interface White noise program. Additional memory for fixed frequencies and 80 set ups in accordance with customer specifications.

Test set up structures of series 18 and 19

Frequency range (50) 80 Hz to 25 MHz

1. TECHNICAL DATA

1.1 FREQUENCY

1.1.1 FREQUENCY RANGE FOR SELECTIVE AND WIDE-BAND MEASUREMENTS

Coaxial input, 75 Ohm	50 Hz ^{+) to 25 MHz}
Balanced input, 124/150 Ohm	10 kHz to 14 MHz
Balanced input, 150/600 Ohm	50 Hz ^{+) to 620 kHz}

^{+) For selective measurements below 2 kHz, the 25 Hz bandwidth must be selected. The lower limit frequency for wide-band measurements is 200 Hz.}

1.1.2 FREQUENCY DISPLAY.....digital, 8-decade,
with LCD
Resolution.....1 Hz

1.1.3 FREQUENCY TUNING
Digital with keyboard,
in frequency steps with direction keys, input of the
step increment with keyboard,
continuously with handwheel over the complete frequency
range,
switchable between coarse and fine tuning

Smallest frequency step, digital..1 Hz
continuous, fine.....1 Hz
coarse.....100 Hz

1.1.4 AUTOMATIC FREQUENCY SEQUENCES

1.1.4.1 Frequency Search

Over the whole frequency range with stop by signal detector and automatic fine tuning to the detected signal with AFC, search speed matched to the bandwidth:

Bandwidth	3.1 kHz	1.74 kHz	400 Hz	25 Hz
Search speed	1 MHz/s	250 kHz/s	20 kHz/s	200 Hz/s

1.1.4.2 Auto Step

Automatic stepping of the tuned frequency in increments between preset frequency limits.

Increments and frequency limits entered with keyboard,

Stepping speed adjustable BN 829/01 0.03; 0.1; ; 300 s

BN 829/02 0.1; 0.3; ; 300 s

1.1.4.3 Tracking

Automatic switching of the tuned frequency between preset frequency limits by a frequency instrument as soon as the level indication disappears, input of the increment and frequency limits with the keyboard.

1.1.4.4 Sweep Frequency Operation (version BN 829/02 only)

Sweep limits are set with the keyboard by entering either the start and stop frequency of the center frequency and the deviation,

sweep sequence: periodic (triangular) or single sweep

Sweep duration adjustable 0.1; 0.3; 1 ; 300 s

Additional facility manual sweep and continuous search
with optimum search speed as
specified in section 1.1.4.1

1.1.5 AUTOMATIC FREQUENCY CONTROL (AFC)

The capture range corresponds to the nominal bandwidth of the selected bandwidth filter as specified in section 1.4.1 (switched off in the case of 48 kHz).

The hold range corresponds to the frequency range specified in section 1.1.1.

1.1.6 ERROR LIMITS OF THE TUNED FREQUENCY... $\pm 3 \times 10^{-7}$ with optional accessory BN 865/00.03... $\pm 1 \times 10^{-7}$

The above error limits are valid for the rated operating ranges of ambient parameters listed in section 1.9, including aging in the first year.

1.2 LEVEL

1.2.1 MEASURED PARAMETERS

Absolute level

as power level (dBm), refer to 1 mW, or
as voltage level (dB), refer to 0.7746 V.

Differential level (dB) between an absolute level and a stored reference level. Any absolute level can be stored as a reference level by depressing a pushbutton.

Reduced level (dBm0 or dB0)

Additional features with optional accessory

BN 829/00.02 or BN 829/00.03 :

- reduced noise level (dBm0p)
- reduced noise power (pW0p)
- noise power ratio NPR (dB).

1.2.2 RESULT INDICATION, RESOLUTION, RANGE SELECTION

- 1.2.2.1 Result Indication⁺, switchable.....digital or analog
- Digital display.....LCD with 5 digits and sign
- Analog display....Meter with switchable ranges and digital indication of the level value for 0 dB meter indication.

Ranges of the meter: 1 dB scale.....-1.5 to +0.3 dB

20 dB scale.....-20 to +2 dB

80 dB scale.....-80 to +0 dB

⁺) Noise signals such as the sum level of active CF systems, thermal noise, or intermodulation noise result, due to the rectifier characteristic, to practically the same indication as a sinusoidal signal with the same RMS value. Crest factor: 12 dB.

1.2.2.2 Resolution of the Digital Display

Selective mode, indication averaging on	0.01 dB
indication averaging off	0.1 dB
Wide-band mode	0.1 dB

Levels which cause wide variations of the indication, for example due to overlaid interference signals or to insufficient offset from the intrinsic noise, are displayed with a resolution of 0.1 dB, even if indication averaging is switched on.

1.2.2.3 Range Selection

For digital display: Automatic with overdrive monitoring of the wide-band section during selective measurements.

For analog display: Single automatic cycle on depression of a push-button with overdrive monitoring of the wide-band section for selective measurement of manually with the range switch in 1 dB or 5 dB steps, depending on the selected range of the meter.

In addition to remote control:

Adjustment of the measurement range in 1 dB steps, with the choice of the wide-band drive signal from 3 modes:

low noise, normal, low distortion

Dynamic range in the selected range ± 10 dB

(over- and under loading are indicated)

For very fast measurements, the short averaging feature permits a measurement to be made even when the receive section has not fully settled.

1.2.3 MEASURING RANGES

1.2.3.1 Absolute Level:

Input	Selective mode		Wide-band mode	
	dBm	dB	dBm	dB
Coax. 75 Ω	-130 to +32	-140 to +22	-50 to +32	-60 to +22
Bal. 124/150 Ω	-120 to +22	-130 to +22	-40 to +22	-50 to +22
Bal. 600 Ω	-130 to +22		-50 to +22	

1.2.3.2 Reduced Level: According to the range of the absolute level specified in 1.2.3.1 for relative level (resolution 0.1 dB): -120.0 to +30.0 dB

1.2.3.3 Reduced Noise Level (dBmOp) and Reduced Noise Power (pWOp)*:

According to the range of the absolute level specified in 1.2.3.1 for relative level (resolution 0.1 dB): -50.0 to +10.0 dB

1.2.4 AUTOMATIC LEVEL CALIBRATION

Automatic level calibration is carried out every two minutes and whenever a parameter is changed such that an error in the level indication could occur.

In selective mode, the frequency of the calibration signal follows the tuning of the receivers; in wide-band mode, the calibration frequency is fixed at 10 kHz.

*) 1 pWOp \cong - 90 dBmOp

For measurements in which the measuring sequence could be disturbed by insertion of a calibration cycle, such as sweep frequency measurements, the automatic level calibration can be switched off.

1.2.5 BASIC INTERFERENCE

1.2.5.1 Intrinsic Noise Level when the measuring input is terminated with Z, with a bandwidth of 25 Hz, for total signal level ≤ -50 dBm (-60 dB):

Input	Intrinsic noise level in dBm (dB)				
	200 Hz	3 kHz	10 kHz	620 kHz	14 MHz
Coaxial, 75 Ohm	≤ -105 $\leq (-115)$	≤ -125 $\leq (-135)$	-130 (-140)		
Balanced 124/150 Ohm		-	-125 (-130)		-
Balanced 150/600 Ohm	-100 (-105)		-120 (-125)		-

200 Hz 3 kHz 10 kHz 620 kHz 14 MHz 25 MHz

Increase for other bandwidths:

Bandwidth	400 Hz	1.74 kHz	3.1 kHz	48 kHz
Increase with respect to B = 25 Hz	6 dB	12 dB	15 dB	27 dB

For a total signal level ≥ -50 dBm (≥ -60 dB), the intrinsic noise level rises, corresponding to a signal-to-noise ratio of approximately 80 dB for all bandwidths (except 48 kHz) and $f \geq 3$ kHz.

1.2.5.2 Interference Level of Discrete, Non-harmonic Signals

Synchronous (varying as receiver is tuned)..... \leq -150 dBm
(-160 dB)
Tunable (not varying as receiver is tuned)..... \leq -120 dBm
(-130 dB)

1.2.6 HIGH-SPEED SIGNAL DETECTOR FOR RAPID SIGNAL DETECTION,
ACTIVE ONLY WITH ANALOG DISPLAY

The threshold referred to 0-dB meter indication
on the 1 dB scale.....approximately -1.2 dB
on the 20 dB scale.....approximately -15 dB
on the 80 dB scale (for search only)...approximately -40 dB

1.2.7 ERRORS OF THE LEVEL INDICATION

Unless otherwise stated, the specified error limits are valid for the nominal operating conditions shown in section 1.9, with automatic level calibration on, with the input supplied from a source with an internal impedance Z, and with the test input terminated with Z. Level errors caused by the reflection factor of the input impedance are thus included in the error limits.

1.2.7.1 Error Limits in Selective Mode (included in the total error)

Error limits for 0-dB (0dBm) input level
with digital display and indication averaging or with analog display (1 dB scale), for bandwidths 25 Hz to 3.1 kHz at $(23 \pm 3) ^\circ\text{C}$:

Input	Error limits/dB									
	50 Hz	200 Hz	2 kHz	10 kHz	60 kHz	100 kHz	620 kHz	14 MHz	25 MHz	
Coaxial 75 Ohms	± 0.50	± 0.12	± 0.10							
Balanced 124/150 Ohms	—			± 1.0	± 0.20			—		
Balanced 150/600 Ohms	± 1.0	± 0.20	± 0.15			± 0.20	—			

Extension of the error limits 1.2.7.1 for any input level with ≥ 35 dB above the basic interference specified in 1.2.5.....± 0.08 dB

Average temperature coefficient in the nominal operating range of the ambient temperature, referred to 23 °C.....± 0.006 dB/K

Variation of the supply voltage within the nominal operating range causes no noticeable indication change.

1.2.7.2 Total Errors * (Combining of the partial errors according to 1.2.7.1) in the nominal operating range of the ambient temperature for input levels ≥ 35 dB above the basic interference specified in 1.2.5, with digital display and indication averaging or with analog display (1 dB scale), bandwidth 25 Hz to 3.1 kHz.

(For digital display with indication averaging off, the values in the table below are increased by the rounding error corresponding to the reduced resolution, as specified in 1.2.2.2).

* see also page 1-28

Input	Error limits/dB							
Coaxial 75 Ohms	$\pm 0.5^{x)}$		± 0.2					
Balanced 124/150 Ohms	—	± 1	± 0.3			—		
Balanced 150/600 Ohms	$\pm 1^{xx)}$		± 0.25		± 0.3	—		
	50 Hz	200 Hz	10 kHz	60 kHz	100 kHz	620 kHz	14 MHz	25 MHz

- x) For input levels -65 dB (-55 dBm) to +22 dB (+32 dBm)
- xx) For input levels -55 dB (-45 dBm) to +10 dB (+10 dBm)

Additional error added to the table values above

For 48 kHz bandwidth ± 0.5 dB

For analog display, 20-dB-scale (-5 to +2 dB) ± 0.2 dB

80-dB-scale ± 2 dB

Additional error added to the table values above if the reduced noise level or reduced noise power is displayed ± 0.7 dB

For digital display with switched off indication averaging, the tabulated values raise by the rounding-off error of the decreased resolution, according to para. 1.2.2.2.

Additional error for shortened indication averaging (only with Auxiliary Device BN 853/02) ± 0.4 dB

1.2.7.3 Frequency Response of the Level Indication

referred to $f = 10$ kHz (100 kHz for 124/150 Ω input), for input levels $\cong 35$ dB above the basic interference specified in 1.2.5, for ambient temperature of $(23 \pm 3)^\circ\text{C}$, with digital display and indication averaging or for analog display, bandwidth 25 Hz to 3.1 kHz.

(For digital display with indication averaging off, the table values are increased by the rounding error corresponding to the reduced resolution as specified in 1.2.2.2).

Automatic level calibration on

Input	Error limits/dB								
	200 Hz	2 kHz	60 kHz	100 kHz	620 kHz	5 MHz	14 MHz	25 MHz	
Coaxial 75 Ohms	± 0.08			± 0.06					
Balanced 124/150 Ohms	—			± 0.15			± 0.20	—	
Balanced 150/600 Ohms	± 0.15			± 0.20		—			

Automatic level calibration off (version BN 829/02 only)

Input	Error limits/dB								
	200 Hz	10 kHz	60 kHz	100 kHz	620 kHz	5 MHz	14 MHz	25 MHz	
Coaxial 75 Ohms	± 0.12		± 0.08				± 0.15		
Balanced 124/150 Ohms	—			± 0.15			± 0.25	—	
Balanced 150/600 Ohms	± 0.15			± 0.20		—			

1.2.7.4 Total Error in Wide-band Mode

within the nominal operating range of the ambient temperature, with digital display.

Input	Error limits/dB					
Coaxial 75 Ohms	±0.5					
Balanced 124/150 Ohms	—	±0.6		±0.7		—
Balanced 150/600 Ohms	±0.5		—			
	200 Hz	60 kHz	620 kHz	5 MHz	14 MHz	25 MHz

1.3 PHASE JITTER

The weighting filter and the rectifier characteristic for measurement of phase jitter (peak-to-peak value) comply with CCITT recommendation Q.91.

For measurements with the test tone 1020 ± 10 Hz in the speech channel or in a CF channel, the receiver must be tuned to the center of the channel; otherwise, it is tuned to the test signal frequency.

1.3.1 MEASURING RANGE

Phase jitter is indicated digitally or on the analog meter

Indication range 0.3 to 30°

Resolution of the digital display Max. 0.1°

1.3.2 ERROR LIMITS OF THE INDICATION

at 150 Hz jitter frequency and signal level

≅ -60 dB (-50 dBm) ±10% ±0.3°

(The most favorable level range is automatically selected and an error indication is provided if the signal level is too low).

1.3.3 OUTPUT FOR DEMODULATED PHASE-JITTER SIGNAL (WITH SERIES D)

During the jitter measurement, the demodulator output has the demodulated phase-jitter signal applied to it.

Output signal proportional to meter reading Level

for 30° reading with 600 Ω load approx. -10 dB

1.4 SELECTIVITY AND HARMONIC RATIO

1.4.1 SELECTIVITY, SWITCHABLE:

Nominal value (3 dB bandwidth)	25 Hz	400 Hz	1.74 kHz	3.1 kHz	48 kHz *)
Equivalent noise bandwidth	—	400 Hz	1.74 kHz	3.1 kHz	48 kHz
Offset from filter center for attenuation ≥ 50 dB	± 80 Hz	—			± 35 kHz
≥ 60 dB	± 250 Hz	± 2 kHz	± 2 kHz	± 2 kHz	—

*) The specified filter characteristics are achieved by sweeping the tuned frequency over a 48 kHz band and integration of the input signal spectrum which falls within this band.

1.4.2 IMAGE FREQUENCY AND IF SUPPRESSION..... ≥ 70 dB

1.4.3 DISTORTION PRODUCTS

for basic frequency level ≤ 0 dB (+10 dBm) with automatic range selection or with manual range selection and 50 dB sensitivity above the measuring range of the basic frequency level.

1.4.3.1 Harmonic Distortion Products a_{K2} and a_{K3} for

Load in the frequency range ≥ 3 kHz..... ≥ 80 dB
 ≥ 300 Hz, bandwidth 25 Hz
 ≥ 70 dB

1.4.3.2 Non-harmonic Distortion Products \cong 80 dB

1.4.4 NOISE POWER RATIO (NPR)

when loaded with a noise band signal 0.3 to 12 MHz.

Wide-band level -25 to +10 dBm, noise gap with $B_{rms} \cong 20$ kHz

anywhere in the band, measuring bandwidth 1.74 kHz and automatic

measuring range selection or manual range selection and 70 dB

increase of sensitivity with respect to the range of the wide-band

sum level approximately 60 dB

1.5 MEASUREMENT PERIODS

The following specifications are guide line values, with which the measurement periods are sufficiently described for practical measurements.

1.5.1 Level measurements with autoranging, automatic calibrator switched off

Bandwidth	25 Hz ¹⁾	400 Hz ¹⁾	1.74 kHz ¹⁾	3.1 kHz ¹⁾	Wideband
Averaging: normal (OFF)	0.6 s	0.4 s	0.4 s	0.4 s	0.4 s
long (ON)	1.8 s	1.5 s	1.5 s	1.5 s	0.4 s

1.5.2 Level measurement with adjustment of the measuring range and the wide-band drive signal via an IEC/IEEE-Bus. Automatic calibration switched OFF:

(with version BN 853/02)

Bandwidth	25 Hz	400 Hz	1.74 kHz	3.1 kHz	48 kHz
Averaging: short ²⁾	100 ms	20 ms	20 ms	20 ms	—
normal (OFF)	500 ms	150 ms	150 ms	150 ms	350 ms
long (On)	1.5 s	1.5 s	1.5 s	1.5 s	350 ms

1) The specified measurement periods are valid for levels with \cong 50 dB separation from the signal loading level. With separations > 50 dB, the values are lengthened through the linearity check by 1 s + 300 ms/5 dB.

2) measured with not completely settled receive section

1.5.3 Lengthening of the measurement periods when automatic calibrator switched ON:
 (the bracketed values are for input level $\cong -10$ dBm/dB)

Bandwidth	25 Hz	400 Hz/1.74 kHz/3.1 kHz	48 kHz	WIDEBAND
Averaging: normal (OFF)	1 s (1.3 s)	100 ms (600 ms)	300 ms (900 ms)	600 ms
long (ON)	1 s (1.3 s)	600 ms (1 s)	-	600 ms

1.5.4 Phase jitter measurement: 3 s

1.5.5 Data transfer, transfer time per character 1 ms

1.6 INPUTS

1.6.1 COAXIAL INPUT

can be converted to all common sockets System Versacon[®] 9
 Frequency range 50 Hz to 25 MHz
 Input impedance, switchable to Z 75 Ω
 or high impedance $\cong 10$ k Ω || 60 pF
 Connection attenuation with high input impedance
 f = 200 Hz to 1 MHz $\cong 0.05$ dB

1.6.2 BALANCED INPUT 124/150 Ω 3-pole CF socket

Frequency range 10 kHz to 14 MHz
 Input impedance, switchable to Z 124 Ω , 150 Ω
 or high impedance $\cong 10$ k Ω || 10 mH || 20 pF
 Connection attenuation with high input impedance
 f = 60 kHz to 620 kHz $\cong 0.05$ dB
 Signal balance ratio, in accordance with CCITT recommendation
 0.121 f = 60 kHz to 5 (14) MHz $\cong 40$ ($\cong 30$) dB

1.6.3 BALANCED INPUT 150/600 OHMS.....3-pole CF socket
 Frequency range.....50 Hz to 620 kHz
 Input impedance, switchable to Z.....150 Ohms, 600 Ohms
 or high impedance..... ≥ 10 kOhms \parallel 2.5 H \parallel 80 pF
 Connection attenuation with high input impedance
 f = 500 Hz to 300 kHz..... ≤ 0.05 dB
 Signal balance ratio, in accordance
 with CCITT recommendation 0.121.... ≥ 40 dB

1.6.4 MAXIMUM PERMISSIBLE INPUT VOLTAGE FOR ALL INPUTS

Overload limit when terminated with Z... $V_{rms} \leq 10$ V
 DC input voltage with high impedance
 termination..... $V \leq 60$ V
 DC to ground at the balanced inputs..... ≤ 60 V

With the unit switched off, the inputs have high impedance.

1.7 ADDITIONAL INPUTS AND OUTPUTS

1.7.1 INPUT FOR EXTERNAL STANDARD FREQUENCY

Connection socket.....System Versacon [®] 9
 Frequencies.....1,2,5 or 10 MHz
 Necessary level.....-20 to +0 dB
 Input impedance.....75 Ohms

1.7.2 OUTPUT FOR STANDARD FREQUENCY

Connection socket.....System Versacon [®] 9
 Frequency.....10 MHz
 Output level into 75 Ohm load.....-10 dB \pm 3 dB

1.7.3 OUTPUT FOR TUNED FREQUENCY

Connection socket.....System Versacon[®] 9
floating
For control ofPS-18,PS-19,PSS-19
Frequency range.....40 to 65 MHz
Output level into 75 Ohm load.....-15 dB \pm 4 dB

1.7.4 IF OUTPUT

Connection socket.....System Versacon[®] 9
Output frequency when tuned to
center of band.....10 kHz
Output level proportional to meter indication,
Level for 0-dB indication into 600 Ohm
load.....-10 dB

1.7.5 Y-OUTPUT VOLTAGE (DC).....3-pole CF socket

DC output voltage proportional to meter indication,
Open circuit voltage for full scale deflection.....+5 V
Internal impedance.....5 kOhms

1.7.6 X-OUTPUT VOLTAGE (DC).....3-pole CF socket

DC output voltage proportional to frequency
within the start and stop frequency limits,
Open circuit voltage at start frequency.....-2.5 V
at stop frequency+2.5 V
Internal impedance.....5 kOhms

1.7.7 DEMODULATOR OUTPUT.....3-pole CF socket

Single sideband demodulation, switchable to normal or inverted
position, frequency position of converted channel
when tuned to center of channel.....0 to 4 kHz

Frequency response in the range 0.6 to
3.4 kHz, referred to 2 kHz.....+ 1 dB
Adjacent channel
attenuation \geq 60 dB

Output level proportional to meter indication
Level for 0-dB indication into 600 Ohm
load.....approx. 0 dB

Psophometrically weighted intrinsic noise at the demodu-
lator output when the relative level is adjusted
in the range -50 to +10 dB, at $f \geq 100$ kHz,
 $Z = 75$ Ohms.....-70 dBm

Intrinsic phase jitter (in accordance with CCITT
recommendation 0.91)..... $\leq 0.3^\circ$
Built-in loudspeaker with adjustable volume.

1.7.8 DISPLAY UNIT CONNECTION SOCKET
for X,Y, and comparison line voltages. Control input
for switching the meter for display of the comparison
line voltage of the display unit. A TTL signal for
control of the pin lift of an X-Y plotter is also avail-
able.

1.7.9 IEC 625 INTERFACE (WITH OPTIONAL ACCESSORY BN 853/02)
for remote control of all unit functions.

1.7.10 DIGITAL INTERFACE
for control of two additional units such as PSS-19, PS-19 or RU-3.

1.7.11 POWER SUPPLY CONNECTION FOR TEST PROBE TK-11
..... short-circuit proof
with automatic basic attenuation compensation of 10 dB

1.7.12 TRACKING GENERATOR OUTPUT (SERIES D ...)
Connector System Versacon[®] 9
Frequency range 200 Hz to 25 MHz
Output impedance 75 Ω
Output level into 75 Ω load, fixed (-19 ± 1) dB/(-10 ± 1) dBm

1.8 MEMORIES FOR FIXED FREQUENCIES AND UNIT SETTINGS

1.8.1 NUMBER OF FIXED FREQUENCIES
freely programmable *) 100
preprogrammed (optional accessory BN 829/00.03) 100
The fixed frequencies can be set automatically by one address step as
described in sections 1.1.4.2 and 1.1.4.3.

1.8.2 NUMBER OF EQUIPMENT SETTINGS
freely programmable *) 11
preprogrammed (optional accessory BN 829/00.03) 40

*) Maintenance of stored data in the case
of mains failure approx. 30 days

1.9 POWER SUPPLIES AND AMBIENT CONDITIONS

All error limits specified in the preceding specifications are
applicable for the following nominal operating ranges of the
parameters, unless otherwise specified.

1.9.1 POWER SUPPLIES
Mains voltage range without switching,
nominal operating range 96 to 261 V
Mains frequency, nominal operating range 47.5 to 63 Hz

Current consumption I_{rms} approx. 1 A
Power consumption.....approx. 50 W
Protection class in accordance with
IEC 348 and VDE 0411.....I

Warming up time..... \geq 15 min

1.9.2 OPERATING CLIMATE

Permissible ambient temperature

Nominal operating range.....+5 to +40 °C

Storage and transport range.....-40 to +70 °C

Radio frequency interference

suppression.....in accordance with Vfg 526/1979 of
the Federal German Post Office

1.10 DIMENSIONS, WEIGHT

Weight.....approx. 21 kg

Overall dimensions without cover (W x H x D in mm):

Table-top unit.....477 x 199 x 432

19" chassis (DIN 41 494).....443 x 175 x 377
(4 units)

19" conversion kit.....BN 700/00.04

1.11 OPTIONAL ACCESSORIES

1.11.1 STANDARD FREQUENCY OSCILLATOR, BN 865/00.03

with increased accuracy..... $\pm 1 \times 10^{-7}$

1.11.2 WHITE NOISE PROGRAM AND FIXED VALUE MEMORY BN 829/00.03

for measuring the idle channel noise of all common systems up to 3600 channels with indication of the noise as

- noise power ratio NPR in dB,
- reduced noise level in dBm0p, or
- reduced noise power in pW0p.

In addition, 100 fixed frequencies and 40 equipment settings can be programmed in accordance with customer's specifications (ask for order form number 5/784 a, b).

1.11.2.1 White Noise Program without fixed value memory BN 829/00.02

1.11.3 IEC 625 INTERFACE BUS BOARD BN 853/02

for control of all unit functions.

1.11.4 PRINTER INTERFACE BN 905/01

can be fitted instead interface board BN 853/02 in SPM-19. Printers with V.24/V.28 interfaces.

Printout of mode, instrument parameters and measured results.

1.12 MEASURING ACCESSORIES

1.12.1 TEST PROBE TK-11, ACTIVE TEST PROBE (SERIES D...)

Frequency range 2 kHz to 160 MHz

Input level

Maximum permissible AC voltage 1 V or +10 dBm (+2 dB)

Maximum superimposed DC voltage 50 V

Attenuation when terminated with $R_i = R_a = 75 \Omega$ at 100 kHz

and 20°C 10 dB \pm 0.1 dB

(with automatic gain correction in SPM-19).

Affects of ambient temperature on attenuation
within the nominal operating range..... \leq 0.05 dB

Frequency response, referred to
100 kHz, up to 100 MHz..... \leq 0.2 dB
up to 160 MHz.....approx. 0.2 dB

Input impedance up to $f = 25$ MHz.....approx. 50 kOhms \parallel 3.5 pF*
up to $f = 100$ MHz.....approx. 5 kOhms \parallel 3.5 pF*
up to $f = 160$ MHz.....approx. 2 kOhms \parallel 3.5 pF*

Intrinsic harmonic ratio for input levels ≤ 0 dB.....
 $a_{k2} \geq 40$ dB, $a_{k3} \geq 50$ dB
for input levels ≤ -20 dB..... $a_{k2} \geq 60$ dB,
 $a_{k3} \geq 70$ dB

Power supplies.....from SPM-19

Permissible ambient temperature

Nominal operating range.....+5 to +40 °C

Storage and transport range.....-40 to +70 °C

Standard accessories:

Connection to unit being tested.....Test prod and ground
clamp with prod

Receiver connection.....Element of the Versacon[®]
system (pin contact)

Optional accessories:

Versacon[®] 9 adapter: S 222

Elements of the Versacon[®] 9 system

Weight.....150 g

* The capacity is valid for the TK-11 without adapter to Versacon[®] 9

Dimensions, in mm, with test prod.....Ø 11 x 105

1.12.2 TEST PROBE TK-12 WITH POWER SUPPLY UNIT TKN-12

The power supply unit TKN-12 is necessary to supply power to the test probe. The level meter is operated in the high impedance position.

1.12.2.1 Test Probe TK-12

Frequency range, unbalanced.....200 Hz to 18.6 MHz
balanced (with CF plug S 804).....200 Hz to 2 MHz

Input level

Maximum measurable level.....0 dB
Maximum permissible AC voltage V_{rms}10 V
Maximum permissible DC voltage.....42 V

Gain, adjustable.....0 dB

Temperature coefficient of gain.....approx. 0.02 dB/10 °C

Intrinsic frequency response of the probe, referred to 1 MHz

Unbalanced 300 Hz to 2 MHz..... $\leq \pm 0.05$ dB
200 Hz to 2 MHz..... $\leq \pm 0.1$ dB
200 Hz to 4.5 MHz..... $\leq \pm 0.2$ dB
200 Hz to 18.6 MHz..... $\leq \pm 0.45$ dB
Balanced 200 Hz to 2 MHz..... $\leq \pm 0.1$ dB

Input impedance
Unbalanced, real component in 10 kHz....approx. 1 M Ω
 Input capacitance.....approx. 15 pF
Balance, real component at 10 kHz.....approx. 1 M Ω
 Input capacitance.....approx. 25 pF

Harmonic ratio for k_2 and k_3
Input level 0 dB and $f = 20$ kHz..... \geq 50 dB
Input level 0 dB and $f = 6$ MHz-..... \geq 40 dB

Symmetry

Rejection factor in the range 200 Hz
 to 2 MHz..... \geq 40 dB

Measured in accordance with CCITT
 recommendation 0.121

Common mode rejection in the range
 200 Hz to 2 MHz..... \geq 40 dB

Standard accessories:

Connection to unit being tested.....Test prod and
 ground clamp or element of the Versacon[®] 9 system
Receiver connectionTo match SPM-19
 or TKN-12

Optional accessories:.....Balanced CF plug S 804

Dimensions with test prod in mm..... \varnothing 14 x 150
Weight of the test probe TK-12.....350 g
Cable length.....approx. 1.2 m

Power supply for TK-12.....Probe power supply
unit TKN-12

1.12.2.2 Power Supply Unit TKN-12

Mains voltage.....110/117/127/220/227/235 V
+10 %, -15 %
Mains frequency.....45 to 65 Hz
Power consumption.....approx. 7 VA
DC output voltage, short-circuit proof..24 V/80 mA
Dimensions, w x h x d in mm.....110 x 50 x 150
Weight850 g
Receiver connection for TK-12.....Element of the Versacon[®] 9
system (pin contact)

General Data

Permissible ambient temperature
Nominal operating range.....+10 to +35 °C
Maximum operating range.....0 to +45 °C
Storage and temperature range.....-25 to +60 °C

1.12.3 REFLECTION FACTOR MEASURING BRIDGE RFZ-14

Frequency range.....100 kHz to 100 MHz
Rated impedance.....75 Ohms
Insertion loss with Z_x connection open..approx. 8 dB
Frequency response in the range 300 kHz
to 60 MHz.....approx. \pm 0.5 dB
Reference impedance.....Built-in

Error limits after calibration, with plug connector BNC,
TNC, or 1, 6/10

300 kHz to 60 MHz.....0.007 \pm 0.10 r²
100 kHz to 100 MHz.....0.015 \pm 0.13 r²

Permissible input power.....0.5 W

Connections for transmitter and
receiver.....Universal socket
Versacon [®] 9

Connections to unit being tested.....Universal socket
Versacon [®] 9

Optional connections.....BNC; TNC; 1, 6/5, 6;
2, 5/6; 1, 6/10

Weight.....200 g

Dimensions, w x h x d in mm,
without connections.....54 x 33 x 27

1.12.4 ADAPTER FEDA-1 (75 Ohm/50 Ohm)

The data are valid for the adapter without connecting
elements at an ambient temperature of 23 °C \pm 5 °C.

Impedances.....75 Ohm/50 Ohm

Frequency range.....0 to 100 MHz

Attenuation6 dB

Error limits of attenuation..... \pm 0.1 dB

Reflection factor..... \leq 0.01

Maximum load..... \leq 1 W

Maximum permissible ambient temperature
at rated load.....0 to +45 °C

Storage temperature -55°C to +60°C

Socket adapters

75 Ω side 2, 5/6 (F) or 1, 6/10 (M/F) or BNC (M/F) or
N-connector (M/F)

50 Ω side BNC (M/F) or N-connector (M/F)

Weight 50 g

Dimensions without adapters, l x d in mm 47 x 16

Abbreviations: (M) = male connector; (F) = female connector

1.12.5 RELAY CHANGEOVER SWITCH RU-3, BN 323/02 (Series N...)

Frequency range d.c. to 100 MHz

Connectors, coaxial Connector system Versacon[®] 9

Impedance 75 Ω

Return loss of inputs and outputs
with the connectors (as chosen) 1.6/10; BNC; TNC; 2.5/6; 1.6/5.6
in frequency range d.c. to 15 MHz ≅ 0.015
in frequency range d.c. to 36 MHz ≅ 0.03

Difference of insertion loss of the two channels ≅ 0.02 dB

Insertion loss f = 0 to 36 MHz ≅ 0.05 dB

Difference between insertion loss
of the two channels ≅ 0.02 dB

Isolation between both channels f = 0 to 60 MHz > 95 dB

Digital Interface, for controlling
through SPM-19 24 pol. Amphenol
female contact

NOTE

1) The above-mentioned error limits take into account the affects of the basic receiver noise up to a signal-to-noise ratio with respect to the measured signal of $\cong 35$ dB. If the signal-to-noise ratio is less than this, the same error limits can be used if the following correction value is taken into account. To do this, the difference ΔL between the signal to be measured L_S or the measured value indicated by the receiver L_{S+N} and the receiver indication L_N of the intrinsic noise level must be determined. The curve α on the graph below shows the indication error, which is always positive.

If the output level of the generator PSS-19 or PS-19 is indicated with remote control by the receiver, the specified error limits are increased by the value a for signal-to-noise ratios $\cong 35$ dB, as shown by curve β .

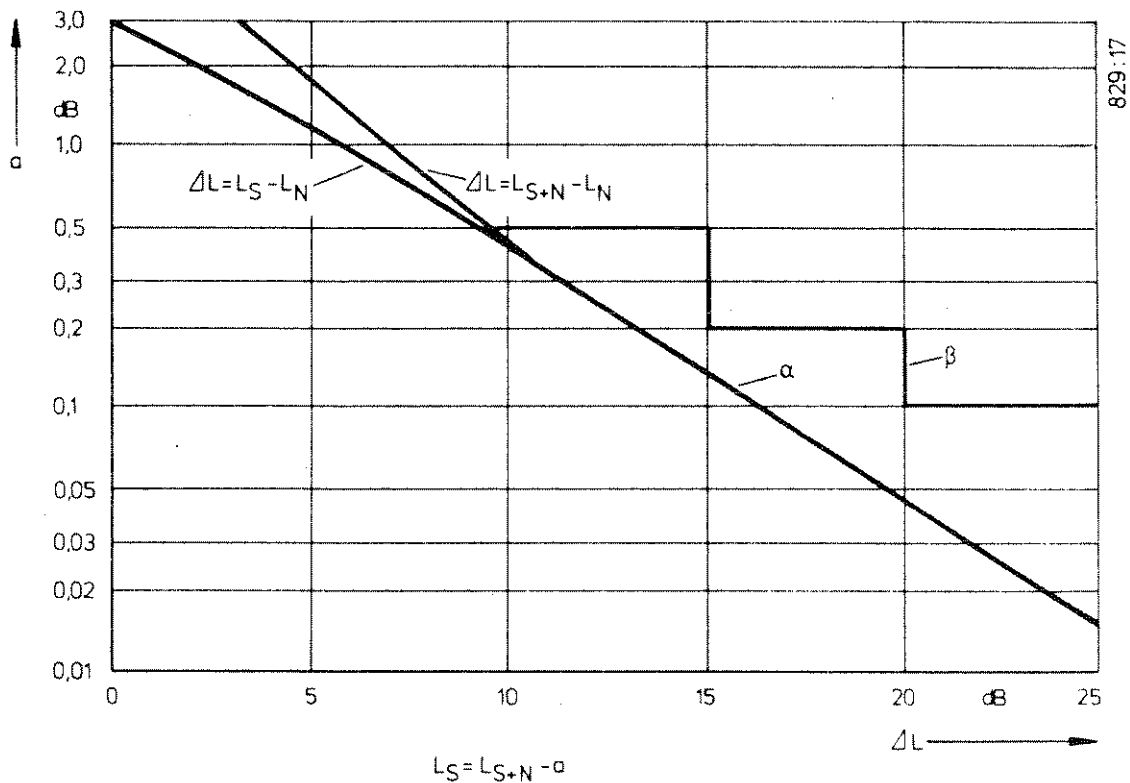

829:17

ORDERING INFORMATION

Level meter SPM-19*	BN 829/01
Level meter SPM-19*	
with sweep frequency section	BN 829/02
Accessories (at extra cost)	
Higher frequency accuracy $\pm 1 \times 10^{-7}$	BN 865/00.03
White Noise Program	BN 829/00.02
White noise program and fixed value memory ²⁾	BN 829/00.03
<u>IEC 625</u> Interface Bus Board	
with Adapter plug IEC 625/IEE 488 (S 834)	BN 853/02
Alternatively:	
Printer Interface V.24/V.28	BN 905/01
Measuring accessories (at extra cost)	
Test Probe TK-11 (with test prod)	BN 573/00
Versacon [®] 9 adapter	S 222
Probe TK-12	BN 574/00
Power supply unit TKN-12	BN 623/00
Balanced plug for TK-12	S 804
Reflection factor measuring adapter RFZ-5 ³⁾	BN 394/00
Reflection factor measuring adapter RFZ-12 ³⁾	BN 810/01
Reflection factor measuring bridge RFZ-14	BN 830/00.01
Signal balance ratio measuring adapter SDZ-12 ³⁾	BN 811/01
Impedance Measuring Attachment SFZ-1	BN 385/04
Adapter FEDA-1 (75 Ω /50 Ω)	BN 319/00
Display unit SG-2 (screen size 85 mm x 120 mm)	BN 429/00
Display unit SG-3 (screen size 150 mm x 210 mm)	BN 593/00
Display unit inserts	see SG-2/SG-3
Relay Changeover Switch RU-3	BN 323/02
Printer TREND 800 RO 8	++
Connection cable for <u>IEC 625</u> interface bus	
120 cm long	K 343
200 cm long	K 344

19" conversion kit for SPM-19	BN 700/00.04
Front and rear covers for SPM-19 (1 set)	SD-4
Equipment case TPK-4	BN 626/10
Transport case TPG-4	BN 621/04

- +) Equipped with the basic 75 Ω socket Versacon[®] 9 and with BNC element. Other elements must be specified when ordering the equipment - see data sheet for Versacon[®] 9.
- 2) The required fixed frequencies (e.g. for the white noise program) and equipment settings must be specified with ordering form No. 5/784 a, b. The white noise program for the SPM-19 requires no specification.
- 3) See the data sheet for measuring adapters for further specifications.
- ++) See data sheet TREND 800 R0 for ordering details and data.

INFORMATION SUBJECT TO CHANGE WITHOUT PRIOR NOTICE

Return Loss

The effect introduced by the return loss of the receiver input or the generator output is included in the error specified for the level reading of a receiver or the output level of a generator.

Moreover, the specified error takes into account that a level meter is operated as "terminated" (input impedance = source impedance = Z_0). This is also valid for a level generator (output impedance = load impedance = Z_0).

Bridging Loss

A receiver operated in the "high impedance" (bridging) mode introduces a level error due to the finite input impedance. The error's maximum value when measured at a testpoint of source impedance $Z/2$ is expressed as a_B , the bridging loss.

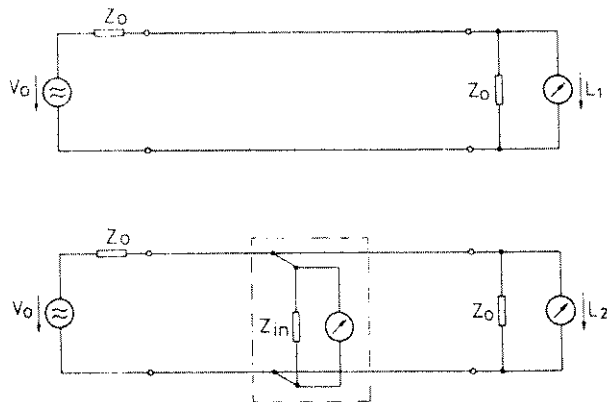

The bridging loss is defined as follows:
Bridging loss $a_B = L_2 - L_1$

$$a_B = 20 \lg \left| 1 + \frac{1}{2} \frac{Z_0}{Z_{in}} \right|$$

Therefore, the bridging loss is the level difference caused by the high impedance level meter input bridging a system terminated with Z_0 .

In every case, $Z_{in} \gg Z_0$, which results in:

$$a_B \leq 4.3 \frac{Z_0}{Z_{in}} \text{ [dB]}$$

For that reason, the specified value of a_B , related to the value Z_1 (e.g. 600 Ohms) can be easily recalculated to yield the value of $a_{B,2}$ for the value Z_2 (e.g. 900 Ohms):

$$a_{B,2} = a_{B,1} \cdot \frac{Z_2}{Z_1}$$

Impedance balance ratio

The specifications given for the input or output balance are provided by the methods defined in CCITT Recommendation O. 121.

This same Recommendation states that:
"The signal balance ratio is an overall measurement of the symmetry of a device and includes the influence of the impedance balance ratio as well as the influence of unwanted longitudinal voltages produced by a generator or the influence of the common-mode rejection ratio of a receiver."

To describe the degree of balance of a device (generator or receiver) under operational conditions in most cases it is sufficient to measure and specify the signal balance ratio only. Thus, the specifications in this Operating Manual are provided by measurement of signal balance ratio. This is done through employment of an accurately center-tapped inductor with both of the tightly-coupled half windings being completely symmetrical. Each half represents $Z/2$.

Measurement of Generator Signal Balance Ratio

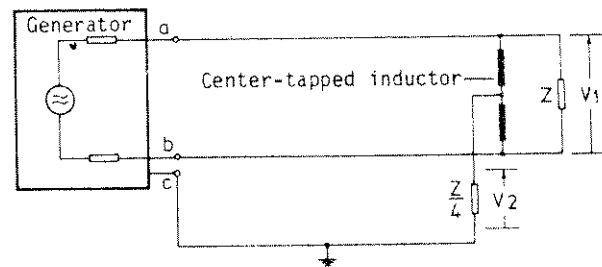

Generator signal balance ratio is defined as:

$$a_B = 20 \log \left| \frac{V_1}{V_2} \right| \text{ [dB]}$$

Measurement of Receiver Signal Balance Ratio

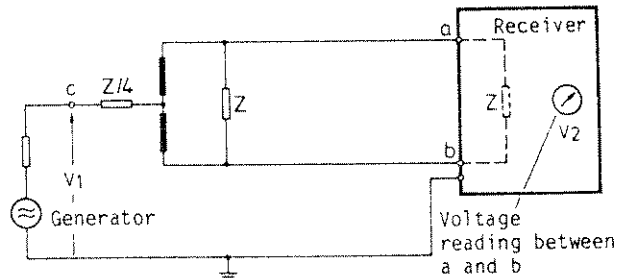

Receiver signal balance ratio is defined as:

$$a_B = 20 \log \left| \frac{V_1}{V_2} \right| \text{ [dB]}$$

The dotted impedance, Z , is the input impedance of the device under test. If the input impedance is a high value, then this impedance must be externally connected in the parallel.

1
2
3
4
5
6
7
8
9
10
11
12
13
14
15
16
17
18
19
20
21
22
23
24
25
26
27
28
29
30
31
32
33
34
35
36
37
38
39
40
41
42
43
44
45
46
47
48
49
50
51
52
53
54
55
56
57
58
59
60
61
62
63
64
65
66
67
68
69
70
71
72
73
74
75
76
77
78
79
80
81
82
83
84
85
86
87
88
89
90
91
92
93
94
95
96
97
98
99
100

TECHNICAL DETAILS

The selective level meter SPM-19 with the wide-band section consists mainly of the modules receiver section, synthesizer, and control section; the latter section includes the microcomputer and the control and display panel. The signal processing and the various modules are described in detail below. (See Figure 2-1).

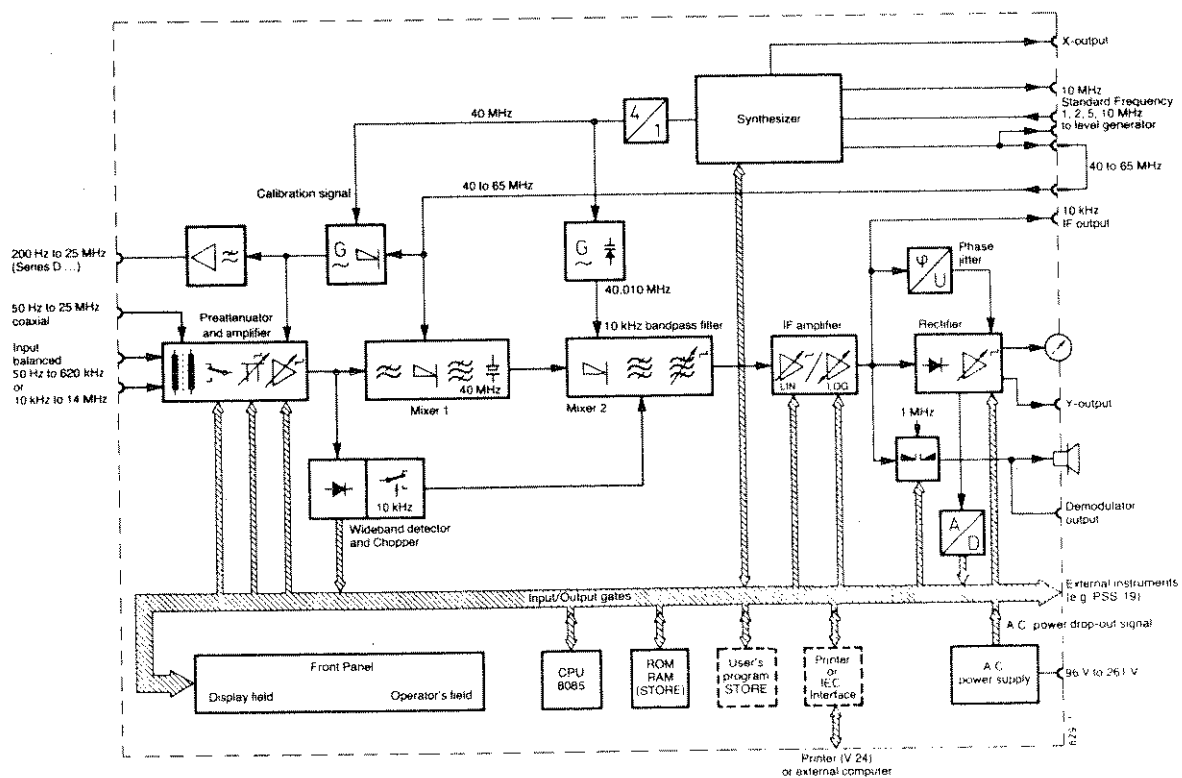

Figure 2-1 Simplified block diagram of the level meter SPM-19

2.1 RECEIVER SECTION

2.1.1 INPUT CIRCUIT AND FREQUENCY CONVERSION

The level meter operates on the double superhet principal. In order to achieve good decoupling between the measuring circuit and the chassis ground for measurement of high losses on 4-pole networks (see section 5.2), the input circuit and the following converter stages are floating, for high frequency purposes, with respect to all other modules (synthesizer, control section, and power supply). The input signal passes from the coaxial input or balanced transformer input, which has an attenuation of 10 dB due to its wide bandwidth and in order to achieve a good frequency response, to the wide-band attenuator and pre-amplifier. For wide-band level measurements, the measured signal is connected to a pseudo-rms rectifier, converted to 10 kHz, and injected into the IF signal path. Here, it is rectified and displayed. For selective level measurements, the wide-band detector acts as a level monitor for optimum matching of the sum signal at the level meter input to the input circuit and the first mixer. The input attenuator and the IF attenuator are adjusted by the microcomputer such that the best possible measuring accuracy is always achieved. This makes manual "low noise/low distortion" switching superfluous.

The preamplifier is followed by a further attenuator which permits optimum matching of the mixer to the wide-band load and switching of the measuring range in 5 dB steps.

The low-pass input filter suppresses all interference and image frequencies which lie above the reception band. The reception frequencies are converted to the first intermediate frequency of 40 MHz in the first mixer, using the 40 to 65 MHz conversion signal from the synthesizer. The

first intermediate frequency passes through a quartz band-pass filter which suppresses the image frequency of the second conversion and the higher mixer products. From this quartz band-pass filter, the signal passes to the second mixer and is converted to the second intermediate frequency of 10 kHz. The necessary carrier signal for this is generated in a 40.01 MHz quartz oscillator which is synchronized to the reference frequency in the synthesizer. The selectivity of the level meter is determined by the flat, 3.1 kHz wide 10 kHz band-pass filter. Various filters with differing noise bandwidths can be connected after this point according to the application.

The high linearity and the low intrinsic noise of the pre-amplifier and of the two mixers makes it possible to achieve a high intrinsic harmonic ratio and a high intrinsic NPR value of approximately 60 dB.

2.1.2 IF AMPLIFIER, RECTIFIER, AND OUTPUT CIRCUIT

The converted received signal passes through a stage for power level matching, according to the selected measuring conditions, either to a logarithmizing circuit with a level range of 80 dB or to the switchable IF amplifier, whose gain can be switched in 1 dB steps with extremely precise transformer-type attenuators. The maximum overall gain is 89.9 dB. This module also contains the calibration attenuator for level calibration (see section 2.1.3). Signal rectification is carried out in a genuine rms rectifier. The crest factor of the rectifier circuit is 12 dB. The rectified measured voltage is either amplified and connected to the meter for analog display or passes through an analog-digital converter for digital level display.

2.1.3 AUTOMATIC LEVEL CALIBRATION

In order to achieve the high measuring accuracy, the SPM-19 is equipped with an automatic level calibration circuit which is automatically switched on at preset intervals or if the equipment settings (e.g. bandwidth, frequency, input attenuator) are changed. The calibration frequency is tuned along with the measured frequency in order to achieve a very low intrinsic frequency response. Only the precise IF attenuators are switched for calibration, the setting of the input attenuator remaining unchanged when the unit automatically switches from measurement to calibration. The extremely precise and temperature constant calibration level of -40 dB is generated in the calibration oscillator. The calibration frequency is obtained by conversion of the modified control frequency and the fixed, multiplied standard frequency from the synthesizer (see section 2.2).

2.1.4 RAPID SIGNAL DETECTOR

A signal voltage at the input to the unit which lies within the indication range of the analog meter is indicated, with the aid of a rapid signal detector, by illumination of an LED. For this purpose, the 10 kHz IF voltage is compared with a reference voltage which corresponds to a level threshold of approximately -15 dB or approximately -1.2 dB on the meter scale. If this threshold is exceeded by the IF voltage, 10 kHz pulses trigger a monoflop which illuminates the LED during its active time of approximately 1 s. During frequency search operations, the signal detector is used to

stop the search. When operating in logarithmic mode, the LED is continuously illuminated; however, search operation is possible at a level threshold of -40 dB reading on the meter.

2.1.5 PHASE JITTER MEASURING ADAPTER

For measurement of the phase jitter, the IF signal is connected to a phase comparator, where it is compared with the average phase of a low jitter reference oscillator with a slow regulation characteristic.

The measured voltage, which is proportional to the phase, is connected via a weighting filter which includes all jitter components in the frequency range \pm (20 to 300 Hz) to the peak-to-peak rectifier, and is then logarithmized amplified, and displayed. The weighting filter and the rectifier characteristic comply with CCITT recommendation 0.91.

2.1.6 TEST PROBE CONNECTION

For high impedance, unbalanced measurements, the active test probe TK-11 is provided. This has the function of an impedance transformer with an input capacitance of only 3.5 pF when a test prod is used. It receives its power supplies from the level meter. The basic attenuation of 10 dB is automatically compensated in the SPM-19 when the TK-11 is connected.

2.1.7 OUTPUTS AND INPUTS

Several outputs are available for further processing of the converted received signal.

In analog mode, a single sideband demodulator permits the reconversion of any voice channel from the CF band to the AF band.

Conversion is carried out with the aid of a switchable carrier signal of 8 or 12 kHz for the normal or inverted position, this carrier being derived from the standard frequency. For reproduction true to the original, therefore, the middle of the channel must be tuned to. The demodulated received signal can either be connected to the built-in loudspeaker for qualitative assessment or extracted at the demodulator output for further external processing (e.g. connection of interruption or pulse noise counters). The demodulator is characterised by low intrinsic noise of 70 dB below the meter display of 0 dB, thus permitting correct conversion of a CF channel.

The last intermediate frequency of 10 kHz can be extracted at a decoupled output which follows the IF amplifier.

The Level Meter (Series D...) has a fixed level output that can be used as a generator sourced signal (tracking generator) for frequency response measurements.

For connection of a plotter or similar device, the level meter has a Y-output at which a DC voltage proportional to the meter indication is available.

An X-output supplies a DC voltage which is proportional to the frequency within the adjustable limits f_{START} and f_{STOP} .

At two other outputs, the variable carrier frequency and the standard frequency can be extracted for the external tuning of a level generator. An input for application of an external standard frequency of 1, 2, 5 or 10 MHz permits substitution for the internal standard frequency.

2.1.8 POWER SUPPLY UNIT

The level meter is equipped with a switching power supply unit which permits connection to mains supplies in the range 96 to 261 V without further switching. It is characterized by a high efficiency, which results in low internal heating inspite of the compact construction.

This provides higher reliability of the level meter.

A built-in rechargeable battery buffers the complete data memory system if the mains supply fails or if the unit is switched off, thus maintaining all stored data and settings.

2.1.9 FREQUENCY TUNING

Frequency tuning is carried out digitally, in BCD code, in all operating modes. For pseudo-continuous frequency tuning in a continuous range, a small DC generator (tacho-generator) is driven by the handwheel and a subsequent voltage-frequency converter generates setting pulses for the internal counters. The frequency information is transmitted to the frequency display and the synthesizer via display buffers.

2.2 SYNTHESIZER

The control frequency of 40 to 65 MHz necessary for tuning of the level meter and the fixed frequencies necessary for synchronization are generated in a synthesizer (BN 865) with the following characteristics:

- High frequency accuracy and stability
- High spectral purity (very low spurious signal and noise levels)
- Phase continuity when the frequency is changed
- High settling rate
- Compact construction.

The construction and the most important modules are shown in the extremely simplified block diagram of the synthesizer in Figure 2-2.

The control frequency f_T (40 to 65 MHz) is generated in a voltage control oscillator which is adjusted such that the control frequency is precisely the sum of the frequency f_R of the locked oscillator and the frequency f_I of the interpolation oscillator.

The locked oscillator operates in the frequency range 39.8 to 64.7 MHz, and can be tuned in 100 kHz steps by a further control loop. For this purpose, the oscillator frequency is divided down to 100 kHz in a programmable locked divider and compared with the standard frequency in a 0-phase controller.

Interpolation within the 100 kHz steps is carried out in a single interpolation loop. This operates with non-integral division ratios, thus permitting frequency settings with values after the decimal point [1].

This arrangement permits high settling rates even with small step increments.

The interpolation oscillator runs at a relatively high frequency between 40 and 60 MHz in order to permit, in the following 200 : 1 divider, reduction of the phase errors resulting from the control loop.

[1] P. Harzer: Frequency Synthesis in Modern Level Measuring Setups. NTZ, Volume 33 (1980), Issue 2, pp 90-94

As the interpolation frequency should be adjustable in steps of 1 Hz, the 200 : 1 divider means that the interpolation divider must be adjustable in 200 Hz steps. In order to permit rapid reprogramming, the output frequency of the interpolation divider is 100 kHz. This is compared with the divided standard frequency in the phase meter. Frequency settings in 1 Hz to 1 kHz positions would result in non-integral division and phase errors. For this reason, a compensation voltage with the same shape as the interference voltage, but with opposite polarity, is overlaid on the output signal from the phase meter.

Further measures, such as synchronous transfer of frequency setting information into the locking and interpolation dividers or the blocking of the carrier loop (carrier phase meter) in the case of a so-called interpolation exchange, permit maximum suppression of the spurious frequencies in the control signal.

The 100 kHz reference frequency and further synchronization frequencies are generated in the time base. This consists mainly of the standard frequency oscillator and the 10 MHz quartz oscillator, with a low proportion of spurious frequencies, which is locked with a rigid phase to the reference frequency via the standard frequency synchronization. The standard frequency oscillator, which can also be replaced by an external frequency standard of 1, 2, 5, or 10 MHz, is thermostat controlled to achieve the high accuracy of 3×10^{-7} or 1×10^{-7} .

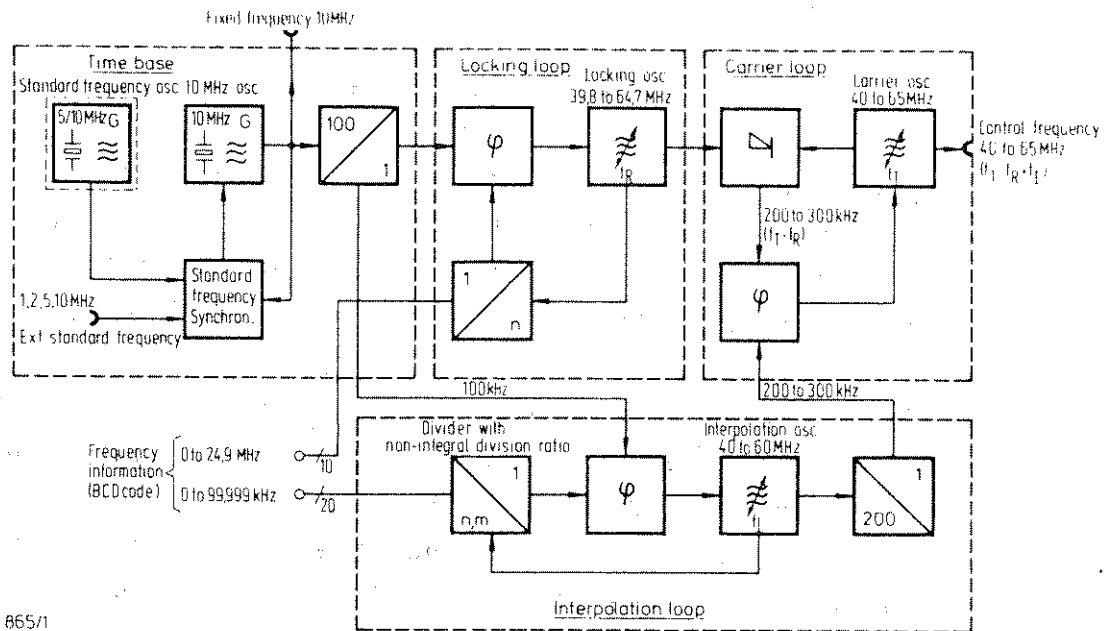

865/1

Figure 2-2 Simplified block diagram of the synthesizer BN 865

2.3 CONTROL SECTION WITH MICROCOMPUTER

The microcomputer consists of the central processing unit (CPU) - a type 8085 microprocessor - the program memory (ROM), the working memory (RAM), and the input and output gates. The displays and controls on the front panel are connected to the microcomputer via data and control lines. The keyboard of the control panel is used, amongst other things, for input of fixed frequencies and complete equipment settings into the working memory. Battery buffering of the RAM power supplies is provided to maintain the stored data in the case of a mains failure.

If required, an additional customer-specific EPROM can be fitted for fixed frequencies, equipment settings, and white noise programs. A result log can be produced on an external printer connected via a printer interface for V.24/V.28 interfaces. Instead of the printer interface, an IEC interface can be fitted for connection of an external computer. Remote control facilities exist for all functions of the SPM-19.

After power is switched on an automatic RAM/ROM test is executed. Functional testing of the most important modules can also be initiated by the operator. In the case of an error, the test sequence is stopped and the error number is displayed.

2.4

PRINTER INTERFACE

The printer interface has its own microprocessor with program memory and RAM (Fig. 2-3).

Directly after the switch-on, the initialization takes place, i.e. the individual modules like e.g. V.24 interface, programmable freq. divider, RAM are set to a definite worthwhile starting status.

In a first step all of the measuring set's data intended for the printout like measured results and instrument settings are transferred to the printer interface (data transfer) and are stored in the RAM.

In a second step, the data are branched exclusively according to the formatting program stored in the program memory and thereafter with additional text are transferred via the V.24 interface to the printer which prints out in the desired form of results.

If a printer with keyboard is to be used for transferring data to the interface, this, likewise, is stored in the RAM according to the instructions, and accordingly further processed. A transfer of this data into the basic unit, however, is not possible.

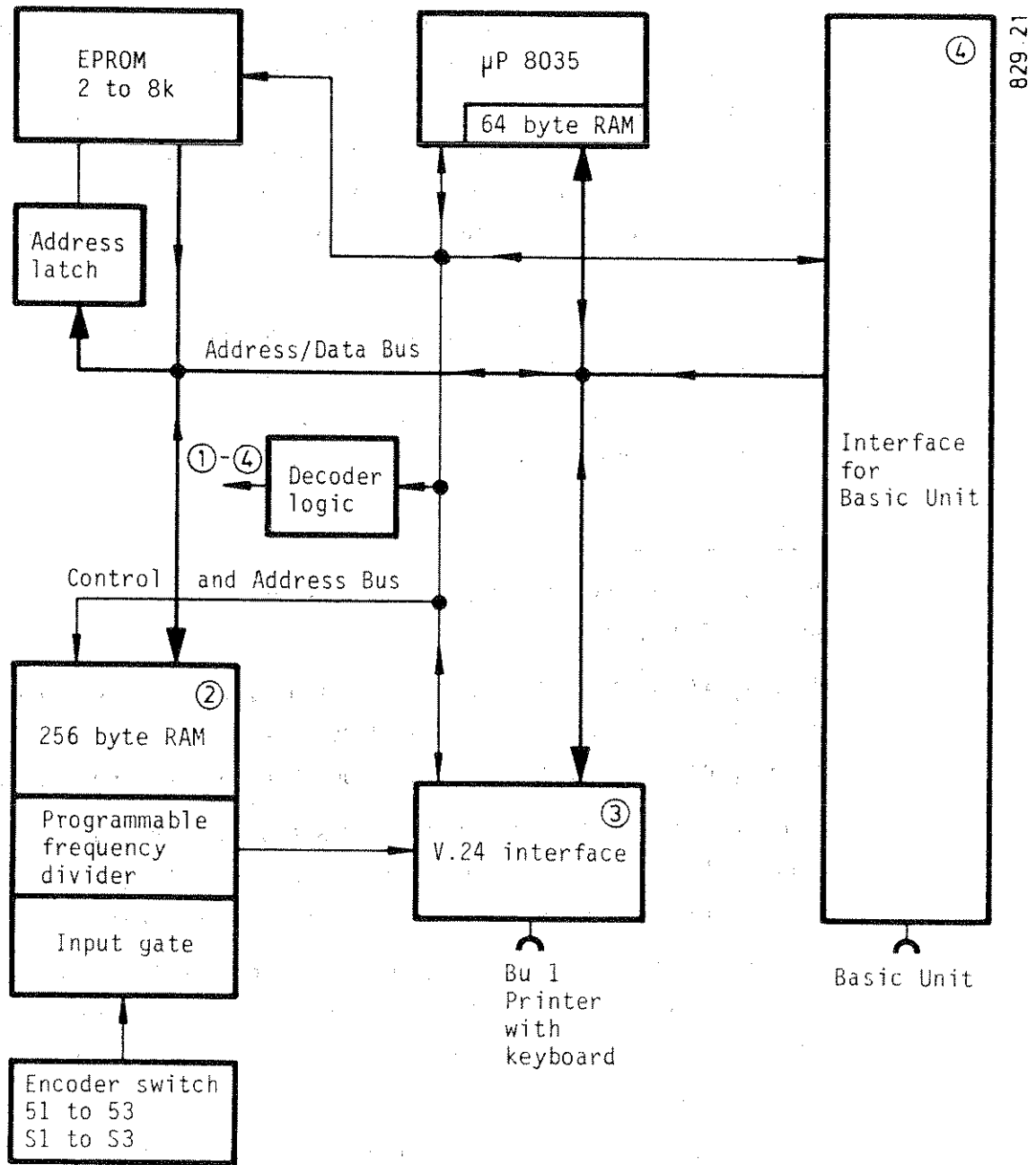

Fig. 2-3

3. COMMISSIONING

3.1 UNPACKING THE UNIT

The SPM-19 is shipped in a special packing case which was subjected to comprehensive stress testing at Wandel & Goltermann before it was certified for general use.

This case guarantees that the test equipment will arrive without damage, even under rough transport conditions. The unit should be removed carefully from the appropriate sides of the packing case. It is recommended that the original packing materials be retained for possible future shipment. If this is not done, please read the following notes.

3.1.1 NOTES FOR SHIPPING

Safe transportation of the SPM-19 is guaranteed only by correctly designed packing materials. If the original packing case has been lost, we recommend that the unit be packed as shown in Figure 3-1.

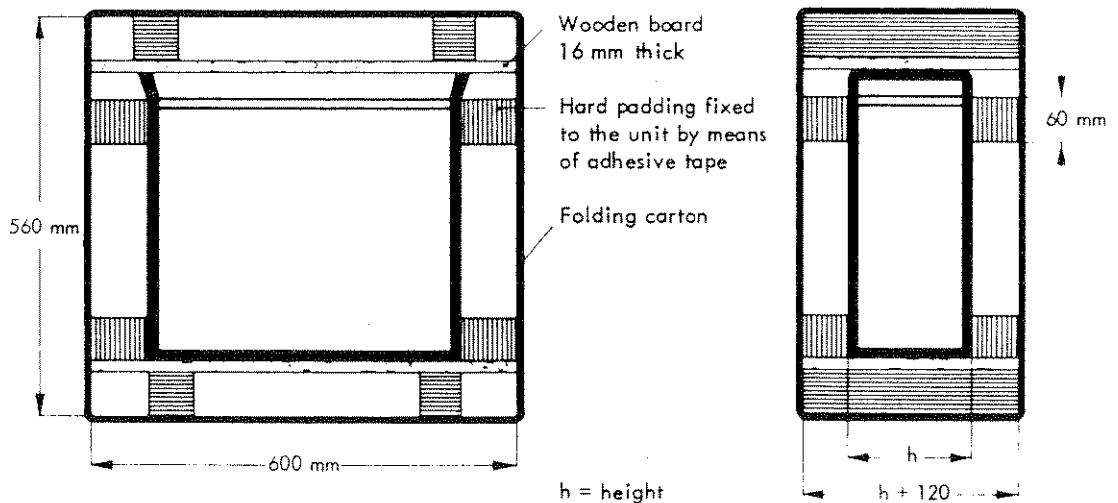

Figure 3-1 Packing notes

3.1.2 TRANSPORT IN THE EQUIPMENT CASE TPK-4 OR TRANSPORT CASE TPG-4

The equipment case TPK-4 protects the SPM-19 against dust and mechanical damage for light transport operations (e.g. in a motor vehicle). It also provides suitable protection against splash water. Further protection of the inclined front panel is provided by placing the rear cover SD-4 on the front of the SPM-19 before putting the unit into the case. For increased climatic and mechanical stresses (e.g. rail or air transport), the transport case TPG-4 is recommended, as this protects the equipment against extreme ambient effects.

3.1.3 USE IN 19" RACKS

The case dimensions of the SPM-19 are matched to DIN Standard 41 494 or American Standard ASA C 83.9 "Racks and front panels". The unit is thus suitable for installation in 19" racks; it is only necessary to modify the front panel dimensions by fitting two mounting brackets as shown in Figure 3-2. The complete 19" conversion kit including mounting screws, is available under order No. BN 700/00.04. The feet on the bottom of the unit and the guide pins on the top of the unit must be removed before installation (see also Figure 3-2).

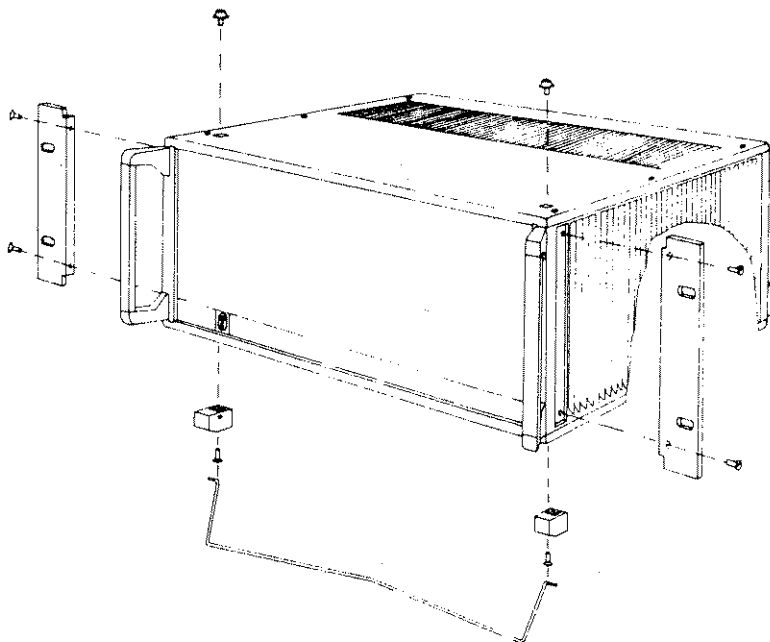

3-2 Figure 3-2 Converting the table-top unit for rack installation

Caution: When installing the unit in equipment cabinets, care must be taken that the upper limit of the nominal operating range for the ambient temperature is not exceeded (see section 3.2). Generally, the following measures are necessary:

A space of one height unit (44.4 mm) must remain free between the units.

If necessary, fans must be fitted to extract the heat generated in the cabinet. Suitable filters should be provided to prevent accumulation of dust on the units.

3.2 INSTALLING THE UNIT

The level meter SPM-19 can be used at ambient temperatures between +5 and +40 °C. If used within larger systems or if installed in racks, care must be taken that this temperature range is not exceeded. (e.g. by spacing the various units as mentioned in section 3.1.3).

Temperatures between -40 and +70 °C are permissible for storage or transport. In such cases, it is recommended that the displays and controls are protected by the transport protection cover SD-4 (see section 1.13, ordering information) on the front and back of the unit; these prevent mechanical damage and protect against dust and splash water.

The angled front panel makes the unit easy and comfortable to use. In addition, the level meter can be installed at an angle by swinging down the supports attached to the front feet. The SPM-19 will also operate reliably in this position.

The liquid crystal displays used for display of frequencies and levels reduce the current consumption and the internal heating of the unit, which means that no fan is necessary and a higher reliability is achieved. When installing the unit, remember that the displays are particularly easy to read if the ambient light levels are high.

3.3 CONNECTION AND SWITCHING ON

Before switching on, connect the control output **52** of the oscillator section to the control input **45** of the receive section using the enclosed short BNC cable (K 336) as shown in Figure 3-3. (Longer connection cables should not be used).

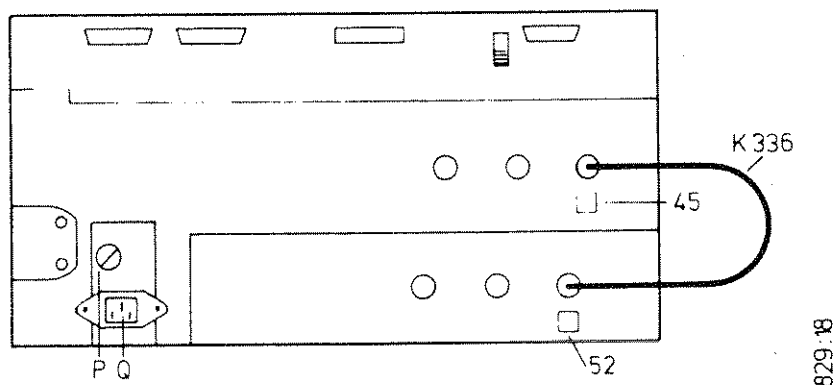

Figure 3-3 Rear connections on the SPM-19

3.3.1 MECHANICAL ZERO SETTING

Before the Level Meter is switched ON, the mechanical zero setting of the analog meter (scale mark ∞) ought to be checked, and if necessary, corrected.

3.4

POWER SUPPLY UNIT

The level meter is supplied with power by a switching power supply unit which is installed on the right side wall of the meter. The SPM-19 can be operated from AC voltages between 96 and 261 V without additional switching, the mains frequency lying between 47.5 and 63 Hz.

The enclosed mains cable should be used for connection to the mains supply. The level meter complies with protection class I of VDE 0411, i.e. the case and the ground socket are connected to the protective conductor. If a different mains cable is used, ensure that a protective conductor is included and connected.

After inserting the mains cable in the mains socket Q (see Figure 4-2) on the rear of the unit, insert the plug into the mains outlet socket and switch on the level meter with the mains switch H on the front (by depressing the pushbutton). The specified error limits are valid only after a warming up period of 15 minutes.

3.4.1

REPLACING THE FUSE

If, when the meter is switched on, there is neither a level nor a frequency display and none of the indicator lamps are lit, first unscrew the fuse holder P on the rear of the unit and check the fuse.

The replacement fuse should be type T 3, 15 A (3.15 A, slow-blow); two spare fuses are enclosed with the unit.

3.5

INTERNAL TEST

When the level meter is switched on, an automatic RAM/ROM test is executed to check the functions of the RAM and the system software (ROM). If the test is executed successfully, the symbols 0----- appear momentarily on the frequency display, followed by the last parameters for frequency and level values stored in the unit. In the case of an error in the control section, an error number is displayed in the frequency display. The digits in the level display (address in hexadecimal code) contain further information for localization of the fault.

Example:



Level display



Frequency display

The meanings of the symbols and digits are explained in Table 6-2.

A functional test of the most important modules (internal hardware test) can be initiated by entering the address No. 9003. No external connections are necessary for this purpose as the internal calibration signal is used as a signal source. The self-test ought to be executed after a waiting time of a few minutes.

Sequence:

Depress the following pushbuttons:



9003



If the test is successful, the symbols 1----- appear in the frequency display. The unit can be switched back from the test program to the measuring program by depressing the blue pushbutton  until the LED is extinguished. In the case of a fault, an error number (e.g. 1--003) appears in the frequency display; the meanings of these numbers are explained in Table 6-2.

3.6

STANDARD SET-UP

All equipment set-ups are stored in a semiconductor memory which is supplied with voltage from a rechargeable accumulator when the mains supply is switched off. For this reason, the last equipment set-up which was stored always appears when the unit is switched on again. Stored fixed frequencies are also retained when the power is switched off.

If the unit is switched off for a longer period, however, it is possible that the buffer battery is exhausted and that the stored information is lost. In this case, the following standard set-up is automatically selected when the power is switched on again:

f = 100.000 kHz
f_{STEP} = 1.000 kHz
Bandwidth 3.1 kHz
Input Z = 75 Ohms
Mode: ABS, ANLG, 20 dB scale
Measuring range: 0 dB
"SWEEP OR STEP TIME" : 1 s

It may be necessary to disconnect the buffer battery during repair work, which also results in loss of the stored data. In order to obtain the defined initial state, the pushbutton T (see Figure 6-2) should be depressed after the unit has been switched on again; this pushbutton is accessible on the control board after removing the upper case cover. Depression of the pushbutton again loads the standard set-up in the memory. (See also the note in section 4.22.1).

If an error occurs during operation, switch the unit off and on again to start the RAM/ROM test. The test is executed automatically as described above. After this, the hardware test can be initiated as described previously.

If neither of the tests results in an error indication, although there is an error in the unit, it is recommended to carry out a reset by calling program number 9000 before resuming measurements. The program is started by depressing the following pushbuttons:

MEM

9000

RCL

Note: This reset clears all stored fixed frequencies (address range 0 to 99); the stored front panel settings (address range 100 to 110) are replaced by a standard set-up as described in section 3.6 (see also the note in section 4.22.1).

Important Safety Instructions

A.C. power line voltage

The operating voltage of the instrument should be the same as the a.c. line voltage, so check whether or not the two voltages are equal.

Safety Class

This instrument is categorized as Safety Class I according to VDE 0411 or IEC Publ. 348. The power cord delivered with the equipment has a protective ground conductor. The a.c. power plug must be plugged into an a.c. power receptacle that has a third wire to ground, except in rooms that are particularly certified otherwise. Any disconnection of the protective ground conductor either inside or outside of the instrument is not permitted.

Connection to measuring circuits presenting hazards to personnel

Before the connection is made to a hazardous circuit, a protective ground connection, for protection against the measurement circuit, ought to be connected to the enclosure. In case the protective ground conductor of the a.c. power line can also assume this protective function, the a.c. power connection should be established first of all. If the measuring circuit has an inherent protective ground conductor, then this conductor must be connected to the enclosure before a connection is made to the measuring circuit.

Defects and Exceptional Conditions

When it can be assumed that safe operation is no longer possible, the equipment should be taken out of service and inadvertent operation should be prevented.

This occurs when

- the equipment shows external signs of damage
- the equipment no longer operates
- after being overstressed in any way (e.g. storage, transport) so that the tolerable limits are exceeded.

Fuses

Only specified fuses are permitted for use.

Opening the Instrument

After the covers have been removed or when components are removed with tools, certain components that operate with applied voltage could be exposed. And also connection points might be carrying a voltage.

Therefore, before the instrument is opened for inspection, all voltage sources should be disconnected.

But sometimes calibration, maintenance or repairs require that the instrument be open and operating with applied voltage. So only experienced craftsmen who understand the dangers associated with working on instruments that have exposed voltage points should undertake the job.

Capacitors can retain a voltage charge even after the instrument has been disconnected from voltage sources. Thus, the circuit diagrams should be observed.

Repairs, Replacement of Components

Repairs must be done according to correct technical practice. With that, particular attention must be paid to the characteristics of construction. None of the safety precautions should be changed, especially for leakage paths and air gaps, and separation by insulation must not be reduced.

Only original replacement parts ought to be used. Other replacement parts are only permitted if the safety and protection against human injury are not degraded through the use of non-original components.

Safety Testing after Repair and Maintenance

Testing of the protective ground conductor in the power cord for the instrument:

The resistance of the protective ground conductor shall be measured. It should be $<0.5 \Omega$. The power cord should be bent and kinked during the measurement so as to reveal any intermittent connection. This gives evidence of a defective power cord.

Testing the insulation of the a.c. power circuit:

The insulation resistance is measured at 500 V between the a.c. power connection and the protective ground conductor connection. For this measurement, the instrument's power switch should be ON.

The insulation resistance ought to be $>2 \text{ M}\Omega$.

Figure 4-2 Rear view

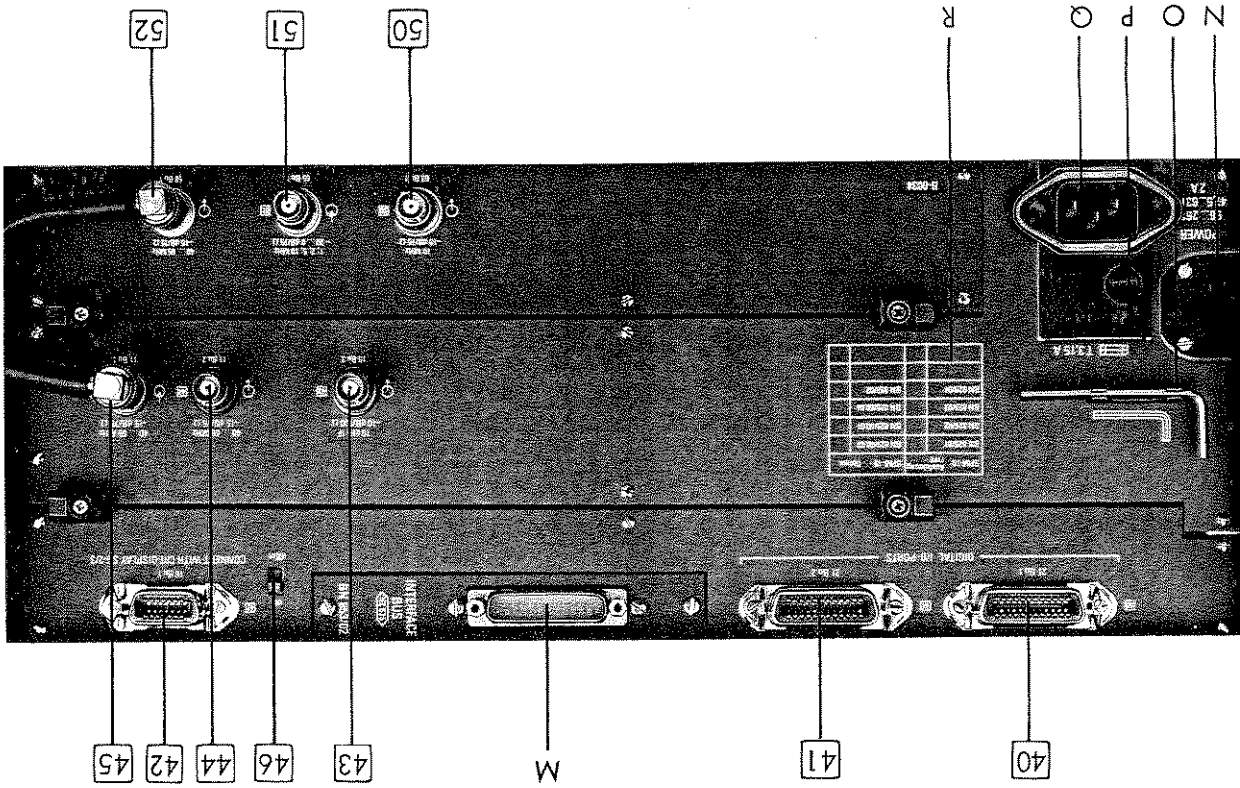
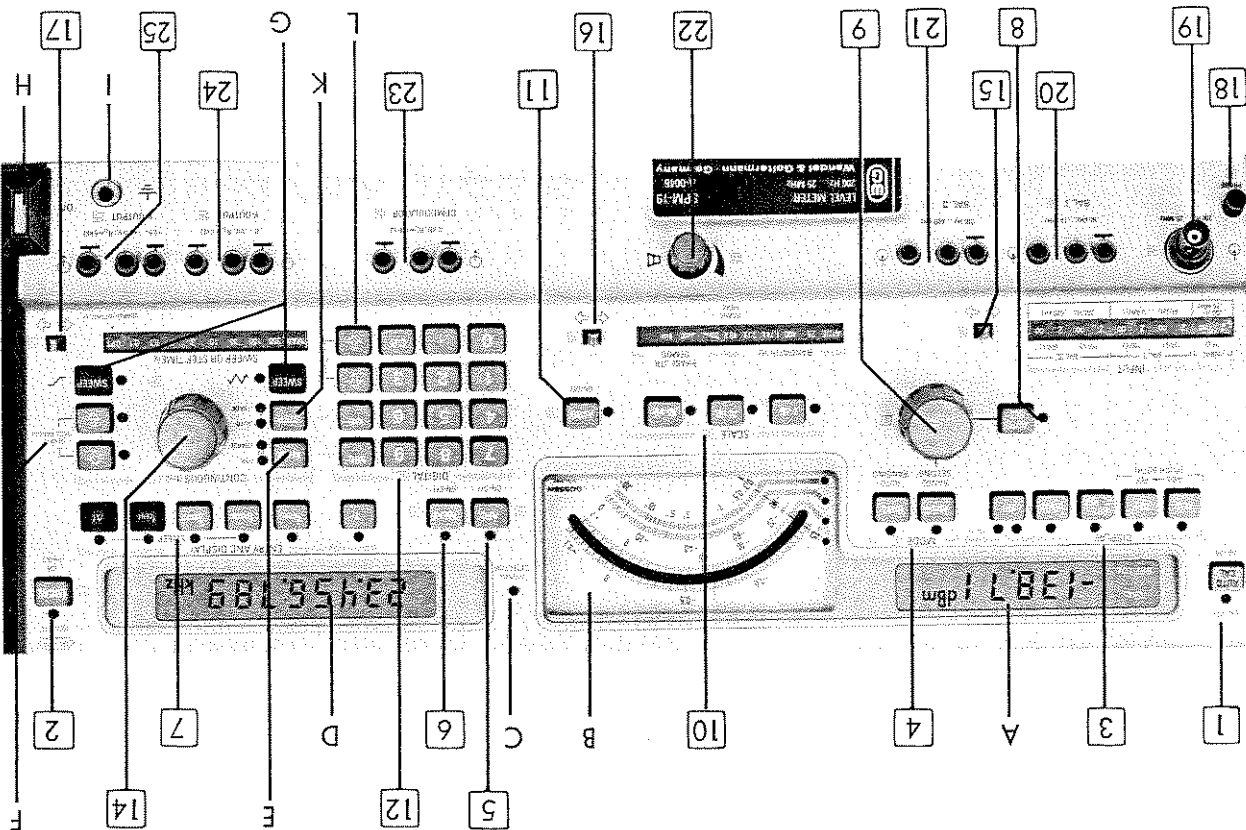

Figure 4-1 Front view, BN 829/02



Controls and Sockets on the Front Panel







(see Figure 4-1)

Control number	Designation in the circuit diagram	Function
1	20 S 10	<input type="checkbox"/> AUTO <input type="checkbox"/> CAL Calibration push-button automatic level calibration can be switched off.
2	20 S 42	<input type="checkbox"/> LOCAL Pushbutton for switching to manual mode during remote control or for manual initiation of printer operation
3	20 S 7 20 S 4	<input type="checkbox"/> ABS <input type="checkbox"/> REF Pushbuttons for display of: Absolute level in dB or dBm. Stored reference level in dB or dBm, level input by simultaneous depression of the pushbuttons <input type="checkbox"/> ABS and <input type="checkbox"/> REF.
	20 S 5	<input type="checkbox"/> ABS-REF Level difference between absolute level and reference level in dB.
	20 S 8	<input type="checkbox"/> dBm0 Reduced level in dB0 or dBm0.
	20 S 9	<input type="checkbox"/> dBr Relative level in dBr, level input by depressing pushbutton twice.
4	20 S 3/ 20 S 1	<input type="checkbox"/> ANLG <input type="checkbox"/> DGTL Selection of operating modes analog or digital

Control number	Designation in the circuit diagram	Function
5	20 S 18	AFC Automatic frequency control
6	20 S 12	MEM Memory pushbutton; used together with the pushbuttons STO and RCL for storage and recall of fixed frequencies or equipment settings.
7	20 S 19...24	Control panel for input and display of single frequency (f), frequency step (f_{STEP}), and sweep limits (f_{START} , f_{STOP} or f_{CENT} , Δf).
8	20 S 2	AUTO SET Pushbutton for automatic setting of the measuring range in analog mode with input signal connected
9	22 S 1	Measuring range switch in analog mode, switching in 1 or 5 dB steps, depending on setting of 10 .
10	20 S 14...16	1 dB 20 dB 80 dB Selection of the required scale range in analog mode.
11	20 S 6	AVRG Changeover switch for rapid or slow display.

Control number	Designation in the circuit diagram	Function
12	20 S 31...41 20 S 43...47	Decimal keyboard for measuring parameter input: Multi-function keys for frequency, relative level (brown) and memory function (blue), clear key CLR .
14	18 Mo 1	Handwheel for continuous frequency tuning together with the push-button MAN .
15	20 S 13	Impedance selection switch.
16	20 S 11	Selection of bandwidth, demodulator, or phase jitter measurement.
17	20 S 17	Selection of the deflection time for sweep frequency operation or the dwell time in AUTO STEP mode, of manual sweep, or periodic search (OPT).
18	14 Bu 1	Power supply for TK-11 probe
19	2 Bu 1	Coaxial input, 50 Hz to 25 MHz.
20	2 Bu 4	Balanced input, 10 kHz to 14 MHz

Control numbers	Designation in the circuit diagram	Function
21	2 Bu 3	Balanced input, 50 Hz to 620 kHz.
22	17 P 1	Volume control for built-in loudspeaker.
23	17 Bu 1	Demodulator output.
24	16 Bu 2	Y-output voltage (DC)
25	18 Bu 1	X-output voltage (DC), voltage proportional to frequency within Δf .
A	22 JC 1	Digital display of level, noise, or phase jitter in digital mode.
B	16 J 1	Meter for level and phase jitter display in analog mode, with mechanical zero correction.
C	19 GL 2	Signal detector
D	19 JC 2	Digital display of frequency. Address, test and error numbers are displayed here for internal test or memory operation.
E	20 S 30	MAN Pushbutton for frequency resolution 100 Hz (coarse) or 1 Hz (fine) during continuous tuning.

Control numbers	Designation in the circuit diagram	Function
F	20 S 25/S 27	  Direction push-buttons for frequency search operation
G	20 S 26/S 28	 Pushbutton for periodic or single sweep
H	1 S 1	Mains switch
I	1 Bu 2	Ground socket
K	20 S 29	 Pushbutton for all automatic frequency stepping with step increment f_{STEP} or for TRACKING
L	20 S 44, S 47	  Direction push-buttons for manual frequency stepping with step increment f_{STEP}

Note: The pushbuttons f_{CENT} , Δf on control field $\boxed{7}$, the controls G (SWEEP) and the settings MAN and OPT in the display field at $\boxed{17}$ are not fitted in version BN 829/01.

Table 4-2

Controls and Sockets on the Rear

(see Figure 4-2)

Control numbers	Designation in the circuit diagram	Function
40, 41	21 Bu 1, 2	Digital interface for control of external devices such as PSS-19
42	16 Bu 1	Connection socket for display unit SG-2 or SG-3
43	15 Bu 3	Intermediate frequency (IF) output, 10 kHz.
44	11 Bu 2	Control frequency output, 40 to 65 MHz, for remote tuning of the generator.
45	11 Bu 1	Control frequency input, 40 to 65 MHz, to be connected to 52.
46	21 S 2	dB/dBm changeover switch.
47	26 Bu 1	Tracking generator output 200 Hz to 25 MHz (Series D...)
50	63 Bu 1	Standard frequency output, 10 MHz.
51	65 Bu 1	Input for external standard frequencies 1, 2, 5 or 10 MHz.
52	58 Bu 1	Control frequency output, 40 to 65 MHz, to be connected to 45.

Control numbers	Designation in the circuit diagram	Function
M	21 (91b)	Installation position for IEC 625 interface bus board or printer interface
N		Battery compartment for Ni-Cd cells for data retention
O		Accessory case for spare fuses, mounting wrench and hexagonal key, and p.c.b. card puller.
P	1 Si 1	Mains fuse
Q	1 St 1	Mains connector
R		Rating plate

4. OPERATION

4.1 CONTROLS ON THE FRONT AND REAR SIDES

The front panel of the level meter SPM-19 is divided into the three functional panels: connection panel, control panel, and display panel. Most of the parameters necessary for measurement are selected with pushbuttons on the inclined part of the front panel, which simplifies operation and provides the unit with a modern design. The left half of the control panel contains the pushbuttons for selecting the required measuring mode, level display, and scale, while the right half of the front panel contains the pushbuttons for frequency tuning.

Each pushbutton has an LED which lights when the function is active. Some of the pushbuttons have double or triple functions (MHz, kHz pushbuttons), which are clearly identified by different colored markings or by a second LED.

The rear side of the unit, on which the division of the level meter into control sections, level measuring sections, and synthesizer is visible, contains the connection sockets for analog and digital control signals, the installation position for the IEC 625 interface bus board, and power supply elements.

The abbreviations used in the operating instructions for controls and sockets are shown in Figures 4-1 and 4-2, which are on fold out pages for ease of use.

The relationships between the abbreviations (normally numbers within square brackets) and the circuit diagrams in the appendix are shown in Tables 4-1 and 4-2.

The abbreviations used in the circuit diagrams have the following meaning for example, 20 S 10 : the switch (calibration pushbutton) can be found in circuit diagram 20 and is marked there with the designation S 10.

The numbers withing square brackets in the tables and text are the same as the numbers printed on the front and rear sides of the level meter. Push buttons are lettered according to function and are referred to by mnemonic.

Examples:

MAN corresponds with push button
20 dB corresponds with push button

The table also provides a short summary of the functions of the various components and sockets. All coaxial connection sockets are universal sockets which can easily be converted to the most common socket types used in communications technology (see section 6.3.4).

4.2 EQUIPMENT SETTING AFTER SWITCHING ON

After commissioning and switching on as described in chapter 3, the level meter SPM-19 automatically sets itself to the parameters and operating modes used for the last measurement before it was switched off. If the built-in buffer battery for retention of data in the CMOS-RAM is exhausted or if it was disconnected from the memories during repair work, a different setting appears. The capacity of the fully charged battery is sufficient to retain the memory data for approximately 30 days with the power switched off.

The voltage to be measured is connected to one of the three inputs of the level meter with suitable cable. All inputs are automatically switched to high impedance when the level meter power is switched off; this avoids any possible effects on the circuits being measured.

Caution:

Only one input may be used at any time for measurement.

4.3 INPUTS, INPUT IMPEDANCES, AND FREQUENCY RANGES

The level meter is equipped with a coaxial input [19] for the complete frequency range from 50 Hz to 25 MHz. The input impedance can be switched between 75 Ohm and high impedance with the impedance selection switch [15].

The two input sockets [20] and [21] are provided for balanced measurements.

The frequency ranges and impedances of the two inputs are:

BAL I [20] : 10 kHz to 14 MHz, impedances 124 Ohms and
150 Ohms

BAL II [21] : 50 Hz to 620 kHz, impedances 150 Ohms and
600 Ohms.

The required input and the input impedance Z or high impedance are selected with the impedance selection switch [15]. The setting steps automatically as long as the switch is depressed. The active input and impedance value are indicated in the illuminated section of the window.

Caution: When terminated with Z, the measuring inputs should be protected against input voltages $V_{rms} \geq 10$ V. The permissible DC input voltage must not exceed 60 V when a high impedance input is selected.

4.4 TUNING THE RECEIVER FREQUENCY

Frequency tuning is carried out, according to the task, either digitally with the keyboard, continuously, or automatically. (AUTO STEP, TRACK, SEARCH).

The use of a synthesizer, which is characterized by very low spurious frequency and noise levels and by phase continuity when the frequency is changed, achieves both high accuracy and high stability of the selected frequency in all operating modes. The frequency accuracy of the SPM-19 is, according to the version $\pm 3 \times 10^{-7}$ or $\pm 1 \times 10^{-7}$ of the displayed frequency value. These error limits include the temperature response in the nominal operating range and the aging errors which occur within one year.

4.4.1 DIGITAL TUNING [12]

The required receiver frequency is entered in MHz or kHz with the aid of the keyboard [12]. (The LED above the blue pushbutton [MEM] must be off).

Example: $f = 0.950$ [.] 95 [kHz]

Leading and trailing (1 Hz to 100 Hz positions) zeros may be omitted. The synthesizer is tuned to the new value only when the [MHz] or [kHz] pushbutton is depressed (ENTER function).

If an incorrect digit is entered during frequency selection, the display can be cleared with the aid of the clear key

and the required frequency reentered. Tuning of the synthesizer is not affected by this. The digits are shifted from right to left in the display. The maximum frequency which can be selected is 26.5 MHz.

A new frequency is entered by overwriting the old value.

The tuned frequency is displayed with a maximum of eight digits in display window D, with a resolution of 1 Hz. The frequency is always displayed in kHz.

4.4.2 CONTINUOUS FREQUENCY TUNING

If the precise value of the frequency to be measured is not known and if it is necessary to tune for maximum level indication (in analog mode), the continuous tuning function can be switched on by depressing the pushbutton in functional panel .

Frequency tuning is carried out in a pseudo-continuous mode, i.e. in steps of 1 Hz or 100 Hz:

if the pushbutton is depressed once, with 1 Hz resolution (FINE)

if pushbutton is depressed twice, with 100 Hz resolution (COARSE).

Due to the phase continuity of the synthesizer, no phase shifts occur during continuous tuning, which means that no additional sideband spectrum is generated.

After selecting the required resolution "coarse or fine", the receiver can be tuned over the whole frequency range with knob [14], without the necessity of range switching, the rate of frequency change per revolution of the knob increasing if the knob is turned faster. This makes it possible to tune through the whole frequency range very rapidly.

If 100 Hz resolution is selected, the last two digits of the frequency display are always zero. Although the upper frequency limits of the level meter is 25MHz, frequencies up to 26.5 MHz can be selected.

To return to digital frequency tuning (4.4.1), the required frequency can be entered directly on keyboard [12].

4.4.3 FREQUENCY TUNING IN STEPS

For measurements at constant frequency intervals (e.g. with channel or primary group intervals, for measurement of harmonic frequencies, or for recording of measuring sequences), operation is particularly simple if the frequency of the SPM-19 can be preset with a stored frequency increment. The unit then permits either manual or automatic frequency stepping.

4.4.3.1 Manual Stepping

- Depress pushbutton f_{STEP}
- Enter the required frequency increment in MHz or kHz (see section 4.4.1).

- Depress pushbutton f and enter the starting frequency (see section 4.4.1).

- The frequency can now be stepped upwards or downwards with the two direction pushbuttons:

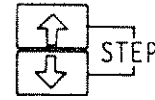

Tuning is possible over the whole frequency range.

The selected frequency increment can be checked by depressing the pushbutton f_{STEP} . The value of the frequency increment is changed by overwriting with a new input.

4.4.3.2 Automatic Stepping

This type of frequency tuning can be used only if the start and stop frequencies are also entered.

Example: Measuring the residual carrier signals in a primary group of 60 kHz to 108 kHz.

Depress the following pushbuttons:

- f_{START} 64 kHz f_{STOP} 108 kHz

- f_{STEP} 4 kHz

- Select the required stepping time in the window "SWEEP OR STEP TIME/s" with switch 17. (The time is stepped automatically as long as the switch is depressed).
- f_{START} (setting the start frequency)
- Depress the pushbutton $STEP$ twice.¹⁾ The LED alongside "AUTO" must light. The frequency is now stepped automatically until the last frequency is attained (f_{STOP}). Another sequence is possible after push buttons " f_{START} ", " $STEP$ (2 x)" have been pressed. If a printer is connected, then cyclical measurements can be run off. The time for one frequency change results from the total of the " $STEP$ " time and the measuring time; this depends on the measuring conditions.

1) In Version BN 829/01 the left position is not occupied in the STEP TIME display window. After the AUTO STEP push button has been pressed, the STEP time sets itself to 300 s.

Note: If the frequency sweep $\Delta f = f_{\text{STOP}} - f_{\text{START}}$ is not an integral multiple of f_{STEP} , then measurements will be carried out only up to an upper frequency $f'_{\text{STOP}} = n \times f_{\text{STEP}} < f_{\text{STOP}}$, i.e. the selected limits are never exceeded. The limits can be exceeded only with the two STEP direction pushbuttons.

4.4.4 TRANSFERRING THE FREQUENCY SETTING TO THE MEMORIES FOR f_{STEP} AND THE SWEEP LIMITS

If pushbutton f is held down and one of the pushbuttons under ENTRY AND DISPLAY 7 is depressed, then the currently selected frequency can be transferred directly to the memories for f_{STEP} and the sweep limits.

This type of frequency setting is particularly advantageous for measurement of harmonic frequencies or for narrow band sweep frequency operation (with center frequency setting, version BN 829/02 only), if the basic frequency or the center frequency (after tuning to the maximum level) has a large number of digits before and after the decimal point (see section 4.13).

Example: Measurement of harmonic frequencies (tuning to $n \times$ basic frequency).

- Tune the level meter to the basic frequency.
- Hold down the pushbutton f and depress pushbutton f_{STEP}
- Tune to the 2nd, 3rd, ... harmonic frequency by depressing the direction pushbutton ↑ the appropriate number of times.

The functions search, TRACK, and sweep are described in sections (4.11 to 4.13).

4.5 AUTOMATIC LEVEL CALIBRATION "AUTO CAL."

The level meter SPM-19 has an automatic level calibration circuit which makes manual calibration unnecessary. It guarantees a high measuring accuracy over the whole frequency range, a noticeable reduction in the measuring times, and high long-term stability.

The automatic level calibration circuit is switched on if the red LED above pushbutton I is not lit.

Calibration is carried out after any parameter change which could result in an error in the level display, for example:

- after switching on
- after a frequency change of more than 10 % for frequencies ≤ 10 MHz or 1 % for frequencies ≥ 10 MHz.
- after switching the bandwidth, the operating mode analog/digital, the meter scale range (1(20)80 dB), the input attenuator and preamplifier, or the measuring mode absolute/relative (analog measurement).

If no parameters are changed, for example during continuous monitoring, calibration is carried out every two minutes. In selective mode, the calibration frequency is always equal to the frequency to which the meter is tuned (frequency display D), thus virtually eliminating frequency response of the SPM-19. In the "wide-band" position of the level meter, calibration is always carried out at 10 kHz.

A black bar and the letters CAL are displayed at the upper left corner of the level display during calibration.

For measuring tasks where the automatic calibration cycle would result in interference, the automatic level calibration circuit can be switched off by depressing pushbutton ; this applies, for example, to measurements with the built-in demodulator. No calibration is carried out during search or sweep frequency operations.

Depression of pushbutton causes the red LED (CAL OFF) to light. Depressing the pushbutton again immediately initiates a calibration operation and switches off the LED.

4.6 SELECTION OF THE OPERATING MODE ANALOG/DIGITAL

Analog or digital level display can be selected with the two pushbuttons ANLG , DGTL . One of the two LED's above the pushbuttons is always lit. Analog level display is advisable for sweep, search, and track operations or if the demodulator is used.

During analog measurements, the measuring range can be selected manually or automatically after depressing a pushbutton; for digital level measurements, adjustment of the attenuator is always carried out automatically.

Automatic range setting during selected measurements is always executed with an automatic overdrive check of the wide-band section. The principle used here has the advantage that measurements are always carried out at the optimum settings of the meter, thus achieving the maximum measuring accuracy. The changeover switch "low noise/low distortion", which often caused confusion, is no longer required.

4.6.1 DIGITAL LEVEL MEASUREMENT

Depression of the pushbutton DGTL switches off the meter B and the result of measurement is displayed in the digital level display A as follows:

4_digits_(resolution_0.1_dB)

for wide-band measurements

for selected measurements with rapid display (LED beside pushbutton AVRG is off).

5_digits_(resolution_0.01_dB)

for selected measurements with slow display (LED beside pushbutton AVRG on).

Input levels which cause major deviation of the display, for example due to overlaid interference signals or insufficient displacement from the intrinsic noise, are always displayed with a resolution of 0.1 dB, even if display averaging is switched on (see also section 4.6.4).

The following parameters can be displayed or stored by depressing the pushbuttons on DISPLAY control panel 3 :

4.6.1.1 Absolute Voltage or Power Level ABS

Depression of the pushbutton ABS causes the absolute value of the signal at the input to be measured and displayed. The required calibration voltage level (dB) or power level (dBm) must be selected with the slide switch 46 on the rear of the unit before switching on the level meter.

The required calibration can also be selected via the keyboard 12 .

dB calibration: MEM 9900 RCL

dBm calibration: MEM 9901 RCL

The fundamental setting after the Level Meter has been switched ON results, however, always according to the setting of slide switch 46 .

4.6.1.2 Level Difference

For measurements of the frequency response or of harmonic frequencies, the level with respect to a reference value is more interesting to the user than the absolute level. For these measurements, the absolute value is first determined as described in section 4.6.1.1 and then stored as the reference value. This is done by depressing pushbuttons ABS and REF simultaneously.

The new, stored reference level is now displayed in display A with a resolution of 0.01 dB. To display the reference level, simply depress the pushbutton REF .

Up to 11 different reference levels (e.g. intrinsic frequency response of a comparison object) can be stored with the MEM function (see section 4.22).

Any required reference levels can be programmed if the level meter is used together with a computer.

Depression of the pushbutton ABS-REF causes the difference between the measured level (absolute value) and the reference level stored as described in section 4.6.1.2 to be displayed in dB. The resolution of the display depends on the conditions mentioned in section 4.6.1.

How digital level difference measurements (channel A - channel B) are made at higher accuracy is described in para. 4.25.2.

4.6.1.3 Levels reduced to dBm0 values

In communications technology, levels are often not specified as absolute values, but as values referred to the relative level (dBr) of a test point. In order to simplify evaluation of such levels, the relative level can be set between the limits

-120.0 and +30.0 dBr.

The result of measurement is then displayed directly as a "reduced level" in dBm0 (dB0) if the pushbutton is depressed. Any reference level can be entered instead of the relative level (dBr).

a) Display of the relative level

The last relative level which was stored can be displayed by depressing pushbutton once (left LED lights).

b) Input of the relative level (dBr)

- Depress pushbutton dBr once or twice until both LED's above the pushbutton are lit.

- Enter the required dBr level on the numerical keypad.

(Numerical value and units with sign)

Negative values (-dBr) with pushbutton

Positive values (+dBr) with pushbutton

Depression of the units pushbutton transfers the new value to the memory (and the frequency display again appears).

Depression of the pushbutton causes the level to be displayed not as an absolute value, but referred to the stored (relative level) (dBr) as reduced to a level in dBm0 or dB0.

The following relationship applies: $a \text{ dBm0} + b \text{ (dBr)} = (a + b) \text{ dBm}$

At the "0 dBr point", the reduced level is equal to the absolute level.

4.6.2 ANALOG LEVEL MEASUREMENT

Depression of the pushbutton switches off the digital level display and switches on the analog meter. The digital display A now

shows the measuring range i.e. the level value for the 0 dB mark on the instrument, which can be switched, according to the selected scale 10, in

- 1 dB steps for the 1 dB scale or
- 5 dB steps for the 20 dB and 80 dB scales.

Result of measurement = digital display (measuring range) + meter reading (scale value).

4.6.2.1 Measuring Range Selection

The measuring range is selected:

- a) manually with the measuring range switch 9 or
- b) automatically by depressing pushbutton AUTO SET.

In the case of manual selection (input of the measuring range for sweep operations or the level threshold for search operations), select a measuring range such that measurements are carried out at the upper end of the 20 dB scale (for accuracy reasons).

If automatic range selection is activated by depressing pushbutton AUTO SET once, the measuring range is always set such that the meter indication is to the left of the 0 dB mark.



The advantage of this lies in the simple addition of two negative values (measuring range and analog value) in most applications.

Maximum extent of the measuring range:

for the 1 dB scale : +20 dB (+30 dBm) ... -120 dB (-110 dBm)

for the 20 dB scale: +20 dB (+30 dBm) ... -120 dB (-110 dBm)

for the 80 dB scale: +20 dB (+30 dBm) ... - 40 dB (-30 dBm)

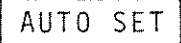
Note: If, when the 80 dB scale is selected or when the unit is switched from the coaxial to the balanced input, a direction arrow  appears in the measuring range display for the most sensitive measuring range (see section 4.6.3), turn rotary switch  anticlockwise (against the direction of the arrow) or depress the pushbutton  . If the arrow appears in the 1 dB range, turn the rotary switch anticlockwise and then clockwise again or depress a function key.

4.6.2.2 Scale Range

Three scale ranges are available for level display. The required range is selected by one of the three pushbuttons 1 dB, 20 dB or 80 dB; at the same time, the LED for the appropriate scale in the meter is lit (see Figure 4-3).

The scales span the following:

1 dB scale: -1.5 to +0.3 dB

Used for measurement of single, discrete signals with maximum accuracy or for measurement of small level differences.

20 dB scale : -20 to +2 dB

Use for general measurements, for noise measurements, during search or track operations, or for distortion measurements.

80 dB scale : -80 to +0 dB

Used for overview and sweep frequency measurements with large level differences.

The bottom scale on the meter is used for measurement of phase jitter (see section 4.9) in analog mode. The range extends from 0.3 to 30 ° and is divided logarithmically to permit indication of small jitter values with maximum resolution.

LED's for

Level display

expanded (20 G1 84)

normal 20 dB (20 G1 85)

normal 80 dB (20 G1 86)

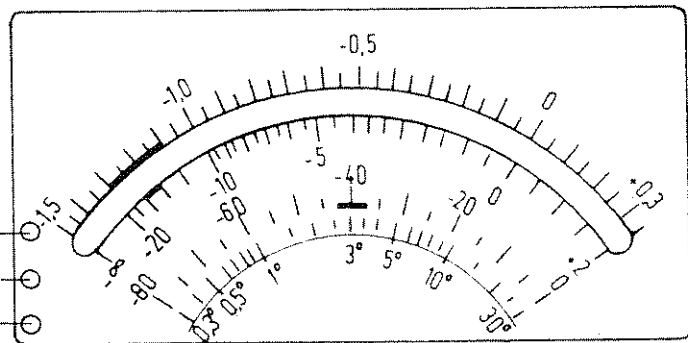

Figure 4-3 Analog meter of the SPM-19 (Series D...)

4.6.2.3 Rapid Signal Detector

The LED alongside the meter is used as a tuning aid for rapid location of unknown signals when tuning manually in 1 dB or 20 dB scale range.

If the frequency of the level meter is changed rapidly with knob 14, see section 4.4.2, the signal detector with the LED reacts more rapidly than the relatively slow analog meter. As soon as a signal whose level would result in a deflection above the scale marks approx. -15 dB or approx. -1.2 dB, respectively, is present at the receiver input, the LED lights.

In search mode (see section 4.12), illumination of the LED is also used as a criterion for automatic stopping of automatic frequency tuning.

- Note: 1) In the more sensitive measuring ranges, the LED may also light at a scale indication < -15 dB, according to the selected bandwidth, as the peak evaluation of the signal detector can permit single noise spikes in the receiver noise to activate the diode. This can be prevented by selecting a smaller bandwidth.
- 2) If the 80 dB scale is selected, the LED lights continuously.

4.6.3 DIRECTION ARROWS IN THE LEVEL DISPLAY

Direction arrows in the level display (Figure 4-4) signal an invalid measuring range in analog mode and an invalid result in the digital mode; in digital mode, they also indicate that the level at the meter input is higher \downarrow or lower \uparrow than the currently displayed level during the measurement, as the result of a sudden level change. Direction arrows can also appear with amplitude modulated signals at low modulating frequencies. In this case, it is recommended that the analog meter scale of -20 dB be used instead.



Figure 4-4 Direction arrows in the level display

The direction arrows disappear

in analog mode: in the 20 or 80 dB scale by depressing the pushbutton **AUTO SET** or turning the measuring range switch **9** one position anticlockwise (against the direction of the arrow).

In the 1 dB scale, by turning the range switch **9** one position anticlockwise and then clockwise again or by depressing a function key in DISPLAY panel **3** (the direction arrow indicates that the display expander is not measuring a signal).

Digital mode: after one further measurement.

4.6.4 NOISE AVERAGING **AVRG**

Level measurements are normally carried out with noise averaging switched off (LED off). When signals with overlaid noise or the basic noise of a system is measured, the display would be unstable. In this case, noise averaging is switched on by depressing the pushbutton **AVRG** (LED lights). Thereupon, the measured value is averaged over

a longer period, the average value from a number of single measurements being formed in digital mode.

In digital mode, with selected measurements, and with noise averaging on, the resolution is 0.01 dB. If the signal-to-noise ratio is too low or if the signal fluctuates, the display automatically switches to a resolution of 0.1 dB. Wide-band measurements are always carried out with a resolution of 0.1 dB.

4.7 BANDWIDTH

4.7.1 WIDE-BAND SECTION

The level meter SPM-19 operates in the frequency range 200 Hz to 25 MHz as a wide-band receiver if bandwidth switch 16 is set to the position "WIDE". This mode makes it possible, for example, to measure the wide-band sum level, i.e. the base band load, in all CF systems with 12 to 3600 channels. Measurement of the noise power ratio (NPR) in frequency multiplex transmission systems with the Auxiliary Device white noise program (see section 4.23) also starts with automatic measuring, storage, and further processing of the wide-band level. Due to the rectifier characteristic, noise signals such as the sum level of active CF systems, thermal noise, or intermodulation noise results in practically the same indication as for a sinusoidal signal of the same rms value.

The measured level can be displayed in either analog or digital form. In the case of digital display, the resolution is 0.1 dB.

4.7.2 SELECTIVE SECTION

The SPM-19 can be set to five different bandwidths. Typical selectivity curves of the level meter are shown in section 5.1. Depending on the application, one of the following bandwidths is selected with the bandwidth changeover switch 16 :

Bandwidth 25 Hz

The narrow filter permits level measurements in the frequency range 50 Hz to 25 MHz. It is used mainly for analysis of signal components which are closely spaced, for example for measurement of group or super-group pilot frequencies, or in order to block excessive noise at the input.

Bandwidth 400 Hz

This bandwidth permits level measurements at frequencies of 2 kHz and higher. It is used for sensitive measurements, for analysis of neighboring signals, and to block interfering noise.

Bandwidth 1.74 kHz

This bandwidth permits weighted noise measurements in accordance with CCITT in the speech channels of the CF transmission band and measurement of the noise power ratio (NPR) (see also section 4.23).

Bandwidth 3.1 kHz

The bandwidth of this filter corresponds to the width of a telephone channel. It has a very low ripple in the band-pass and steep edges at the limits of the band. It is used for measurement of the unweighted noise and of the power in single speech channels and is automatically selected if demodulation of single sideband signals is activated (see section 4.8). It is also possible to measure pulse noise in carrier frequency speech channels if an external unit (e.g. DLM-3) is connected to the demodulator output 23 (see section 4.8).

Bandwidth 48 kHz

This bandwidth permits measurement of the power in a primary group.

As the final intermediate frequency of the level meter is 10 kHz, this bandwidth is implemented by rapidly sweeping the SPM-19, with the bandwidth set to 3.1 kHz, around the selected frequency, resulting in an effective bandwidth of 48 kHz, and integrating the measured values. The function "SWEEP" is thus automatically switched on when the 48 kHz bandwidth is selected. Sweep measurements are therefore not possible with this bandwidth; however, the two STEP direction pushbuttons for manual measurements with constant frequency increments or the AUTO STEP function can still be used.

The built-in measuring demodulator of the SPM-19 permits demodulation of received signals which are modulated with a single sideband. An important characteristic of the demodulator is its wide dynamic range of more than 70 dB.

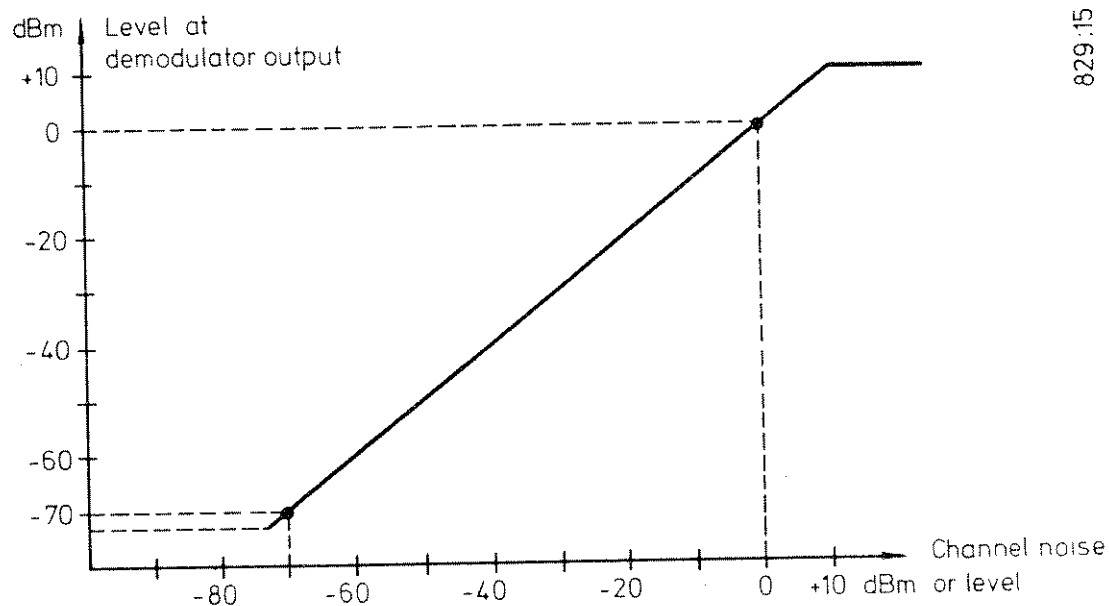

829:15

Figure 4-5 Dynamic range of the measuring demodulator
Relative level -50 to +10 dB_r



The demodulator is activated with the switch 16, in the two positions . The 3.1 kHz bandwidth is always active for these measurements. In addition, the analog mode must be selected. The demodulated received signal is available at output socket 23 with an internal impedance of 600 Ohms. The output level is approximately 0 dBm if the meter indicates 0 dB on the 20 dB scale and if the load impedance is 600 Ohms. The intrinsic noise at the demodulator output is around -70 dBm, and the overdrive limit is approximately +10 dBm.

If CF systems with a maximum of 3600 channels are used, the best drive level is achieved if the relative level (dBr) is set to match the system access point and a measuring range of 0 dBm0 is selected. The dynamic range which can be handled by the unit is shown in Figure 4-5.

Switch 16 permits selection of

 = demodulation of the lower sideband (inverted position) and

 = demodulation of the upper sideband (normal position).

The center frequency of the band is converted to 2 kHz when tuned to the middle of the channel. If the level meter was previously tuned to the suppressed carrier, it must be detuned for correct demodulation, namely by -2 kHz for  and by +2 kHz for . With a bandwidth of 3.1 kHz, this results in a demodulated frequency band of 450 Hz to 3.55 kHz.

If an AF signal in this frequency range is connected to the input of the SPM-19 and is to appear without change at the demodulator output 23, then the level meter must be set to 2 kHz and position .

The demodulated input signal can also be monitored with the built-in loudspeaker. The volume of the loudspeaker can be adjusted with potentiometer 22.

The automatic level calibration circuit can be switched off with push-button AUTO CAL if the short interruptions during the calibration of the signal cause interference with measurements (e.g. in the case of interruption measurements).

Additional instruments such as interruption meters and pulse noise counters can be connected to the demodulator output [23] for further processing of the converted signal. The data line test set DLM-3 from Wandel & Goltermann is suitable for both of the above tasks.

For interruption measurements in accordance with CCITT 0.61, the level meter is tuned to the frequency of the carrier frequency signal and the resulting 2 kHz signal from the demodulator is extracted at output [23]. The automatic level calibration circuit must be switched off.

Due to the wide dynamic range of the measuring demodulator and of the flat 3.1 kHz filter, the level meter is particularly suitable for converting carrier frequency telephone channels into the AF range. In order to avoid measuring errors, particular efforts were made to ensure that all modules which participate in conversion reproduce the characteristics of CF channel converters as closely as possible. For this reason, the SPM-19 can be used with an external counter in accordance with CCITT 0.71 for pulse noise measurements over the whole frequency range of the level meter.

The quartz controlled frequency tuning permits precise counting of events over long periods.

4.9 PHASE JITTER MEASUREMENTS

Phase jitter measurements with digital or analog display can be carried out in order to access the transmission qualities of telephone lines for data transmission.

4.9.1 CAUSES AND EFFECTS OF PHASE JITTER

Phase jitter on data lines which are transmitted through carrier frequency channels results mainly from unwanted phase modulation of the carrier signals participating the frequency conversion on the transmit and receive sides with interference components such as the low frequency ringing signal or harmonics of the mains frequency. The basic channel noise also has a certain effect in creating phase jitter. Phase jitter changes the zero transitions of the data signal and can result in incorrect bits on the receive side after regeneration of the signal.

This makes it necessary to check data lines in order to ensure that their phase jitter values lie within specific maximum limits. In addition national PTT authorities, which have issued regulations with this respect, the CCITT also specifies maximum values.

4.9.2 SETTINGS ON THE LEVEL METER

For measurement of phase jitter in the frequency range 2 kHz to 25 MHz, switch 16 is used to select the position Φ_{pp} and the appropriate operating mode 4 analog (ANLG) or digital (DGTL) is selected. A bandwidth of 3.1 kHz is automatically selected. The weighting filter and the rectifier characteristic for measurement of the peak-to-peak value comply with CCITT recommendation 0.91.

For measurement, the signal level should be > -60 dB (-50 dBm). If the signal is too low or is not present, the SPM-19 generates the following

Error Indication

for analog display: by full-scale deflection of the meter and by switching off the signal detector C.

for digital display: by a warning arrow \uparrow in the level display and a jitter indication of 30.0° .

Tuning

of the receiver depends on the measuring task in question, the following applications being possible:

- a) Measurements of a single tone or in a carrier frequency speech channel in a system, in the vicinity of which no signals (neighboring channels, pilot frequencies, dialling tones) exist except for the measured tones. In this case, the meter is tuned to the tone to be measured.
- b) Measurements in an inactive CF channel. In this case, the SPM-19 should be tuned precisely to the center of the channel. The frequency position of the measured signal within the 3.1 kHz bandwidth has no effect on the measurements.

c) For measurements with the 1020 ± 10 Hz test tone in the speech channel, the SPM-19 must be tuned to 2 kHz.

Display

of the result is either on the logarithmically divided lower scale of the meter or on the digital display, with an indication range of 0.3 to 30° .

The resolution of the digital display is

for phase jitter values $\Phi_{pp} \leq 4^\circ$: 0.1°

for phase jitter values $4^\circ < \Phi_{pp} \leq 10^\circ$: 0.2°

for phase jitter values $10^\circ < \Phi_{pp} \leq 30^\circ$: 0.5° .

The minimum indicated digital value is 0.3° . The intrinsic jitter of the level meter is typically 0.2° .

For external processing of the phase jitter result, the Y-voltage output [24], see section 4.14, can be used for driving a strip recorder.

Likewise, the demodulated phase-jitter signal is available at demodulator output [23] on instruments commencing with Series D. The output level is proportional to the analog meter reading and equals approx. -10 dB for a 30° reading.

4.10 AUTOMATIC FREQUENCY CONTROL AFC [5]

The AFC is used for automatically tuning the synthesizer to input signals whose frequencies are unstable. It can also be used as a tuning aid for input signals whose frequency is not precisely known. In order to permit AFC to function correctly in the case of selective measurements with bandwidths of 25 Hz to 3.1 kHz, the SPM-19 should first be tuned in analog mode until there is a meter indication on the 1 dB

or 20 dB scale. After this, the AFC is switched on by depressing the pushbutton **AFC** , causing the synthesizer to tune itself precisely to the signal frequency and the level indication to reach the maximum value.

In the operating mode SEARCH - see section 4.12 - the AFC is switched on automatically when an input signal (single signal or single spectral line) appears within the pass band of the IF filter (capture range).

The AFC is also active in the digital mode.

If the signal is missing or noisy, the AFC switches itself off and the LED above pushbutton **5** starts to flash.

Although the capture range of the AFC is restricted to the nominal bandwidth of the selected filter, the hold range extends over the whole frequency range of the level meter. If the signal frequency changes slowly, then the frequency display will change accordingly. In this case, the level meter acts as a F R E Q U E N C Y C O U N T E R.

4.11 TRACK MODE

4.11.1 APPLICATIONS

In this mode, the SPM-19 can be used as a tracking receiver for selective, automatic end-to-end measurements without any additional connection for frequency synchronization. Measurement is carried out in CF systems in the gaps between the various groups, which means that the system can remain

active, in contrast to end-to-end sweep frequency measurements with a wide-band receiver (see Figure 4-6). A prerequisite for execution of this measurement is that a level generator with a similar frequency generation system and facilities for storage of a specific number of fixed frequencies is available. (e.g. PS-19, PS-6/60 with OD-600/ODF-601 or PS-8/PS-12 with OD-4/OD-12 and ODF-601). The fixed frequencies correspond to the CCITT recommendations for gap frequencies (additional measuring frequencies).

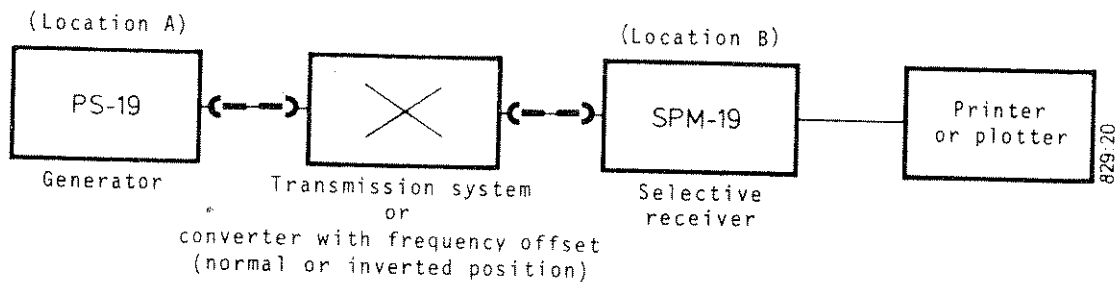

Figure 4-6 Receiver tracking

If the generator and receiver are programmed with identical frequencies (see section 4.22.3), measurement is started by initiating sequential, cyclic transmission of the various frequencies from the level generator (with soft level switching), while the SPM-19 waits at the START frequency in the position "TRACK". When the generator frequency $f_s = f_{START}$, the SPM-19 indicates a level on the analog meter during the dwell time at this frequency. When the generator switches to the next frequency, the level indication disappears and the LED of the signal detector C is switched off. Deactivation of the LED causes the SPM-19 to switch to the next higher or lower fixed frequency, according to the program. The generator and the receiver are now synchronized. A plotter with pen lift function can be connected to the X-Y output [24] [25] or a printer with V.24/V.28 interface can be connected to the printer interface for recording the measured values.

For measurements on converters (channel, group converters, etc.), the generator and receiver frequencies can be programmed with any required fixed frequency offset in the normal or inverted position also see para 4.25.1.

4.11.2 SETTINGS ON THE LEVEL METER

- Enter the fixed frequencies with
 - a) Memory [6] (see section 4.22.3) or
 - b) f_{START} , f_{STOP} , f_{STEP} (see section 4.4.3) (frequency stepping with equal increments).
- Tune the level meter to the starting frequency.
- Select analog mode and the 20 dB scale.
- Set the measuring range with switch [9] to the expected level (\approx approximately full-scale deflection).
- Further settings:

STEP TIME/s		CAL [1]	AVRG [11]
Generator	Receiver		
0.3	0.1	OFF	OFF
1	0.3	ON/OFF	OFF
3	1	ON/OFF	ON/OFF

The switching rate of the generator must be matched to the settling time of the generated level and of the unit being tested, to the settling time of the receiver, and possibly to the time required for a connected printer to print the results.

- Activate the function "TRACK" by depressing the pushbutton [STEP] once. The level meter now waits for the first frequency. It remains at f_{STOP} .

The DC voltage present at the X-output [25] is proportional to the frequency within the start and stop frequency limits.
 Open circuit voltage at f_{START} -2.5 V
 at f_{STOP} +2.5 V

Open circuit voltage per frequency step $f_{STEP} =$

$$5 \text{ V} \cdot \frac{f_{STEP}}{f_{STOP} - f_{START}}$$

The DC voltage present at the Y-output [24] is proportional to the meter indication. The open circuit voltage for full-scale deflection is +5 V.

4.12 SEARCH

The function "SEARCH" permits automatic searching for signals of unknown frequencies which lie above a preset level threshold, such as single interference lines or excessively high levels (hot tones) in transmission systems.

The level threshold is set in the analog mode with the measuring range switch [9], normally in the 20 dB scale range. As the search stops when the signal detector lights, the lower threshold of the signal detector must be taken into account for correct selection of the measuring range. The reaction threshold is as follows for the various scales:

1 dB scale: approximately -1.2 dB

20 dB scale: approximately -15 dB

80 dB scale: at approximately -40 dB (LED lights continuously)

With Level Meters that are connected to printers there is a possibility for entering two exact level thresholds (see 4.25.3.5) that only cause a printout, within the adjusted display range, if the thresholds are exceeded above or below.

Setting example for the level threshold:

Level values > -80 dB should be searched for in the 20 dB scale range. Set the measuring range to $(-80 + 15)$ dB = -65 dB.

In the case of low input levels which lie close to the intrinsic noise of the level meter, it is recommended to select a narrow bandwidth as otherwise single noise spikes could cause the signal detector to react and would block the search operation (see section 4.6.2.3).

Search operation is possible with the bandwidths 25 Hz to 3.1 kHz. The search speed is matched optimally to the selected bandwidth, as shown in the following table. When the 80 dB scale is switched in, the search speed is lower.

Bandwidth	3.1 kHz	1.74 kHz	400 Hz	25 Hz
Search speed	1 MHz/s	250 kHz/s	20 kHz/s	200 Hz/s

Calibration is carried out in accordance with the criteria specified in section 4.5.

Two different operating modes can be selected, these being described in more detail in sections 4.12.1 and 4.12.2.

4.12.1 SINGLE SEARCH F (FULL RANGE)

In this mode, the search function is executed over the whole frequency range, regardless of the stored frequency limits f_{START} and f_{STOP} . It is recommended, particularly for slow search speeds (narrow bandwidths), to set up a starting frequency by depressing pushbutton f or f_{START} and entering the frequency via the keyboard $[12]$. After the level threshold has been set (see section 4.12), the search is started by depressing one of the SEARCH direction pushbuttons. As soon as the signal detector lights, the search function stops. At the same time, the AFC $[5]$ is switched on (see section 4.10) and tunes the level meter precisely to the single or to a discrete spectral line at the meter input.

The search can be restarted at any time by depressing one of the two direction pushbuttons F.

If the input signal is not present or if the measuring range is not sensitive enough, the search function stops at the frequency band limits. The search can be stopped at any time by depressing one of the pushbuttons $[MHz]$, $[kHz]$, $[MAN]$.

4.12.2 CONTINUOUS SEARCH OPTimum, BN 829/02 ONLY

In position OPTimum of the SWEEP TIME changeover switch 17, the search is carried out within the frequency limits specified with f_{START} and f_{STOP} . It is also possible to have the level meter periodically searched for excessively high signal levels, with simultaneous evaluation (printout of level and frequency with SPM-19). This permits automatic system monitoring.

Settings on the SPM-19:

- Enter the start and stop frequencies (f_{START} , f_{STOP}) as described in section 4.4.3.2.
- Select analog mode
- Select the bandwidth and level threshold as described in section 4.12.
- Select the position "OPT" with changeover switch 17 .
- Depress one of the pushbuttons SWEEP.

SWEEP  for periodic search



SWEEP  for single search

Select the starting frequency f_{START} or f_{STOP} .

The search can be stopped at any time by depressing one of the pushbuttons MHz, kHz, MAN .

A plotter can be connected to the X-Y output 24 25 for recording the interference lines.

In the SPM-19 an Auxiliary Device printer interface can be fitted and permits the connection of printers with V.24/V.28 interfaces. In this case, the level and frequency can be printed, followed by an automatic restart of the search operation (see para. 4.25.3).

Note: Should the search operation stop at one of the frequency limits immediately after having been started with the button SWEEP , it is necessary to move the switch 17 away from the position OPT and then back. After this the search operation should be started once again with the button SWEEP .

4.13 SWEEP (VERSION BN 829/02 ONLY)

In the analog mode of equipment version BN 829/02, it is possible to carry out sweep frequency measurements which permit the measuring of test objects with extremely steep flanks, due to the good characteristics of the synthesizer such as high spectral purity and phase continuity when the frequency changes. Figure 4-7 shows the configuration and interconnections of a sweep frequency test set-up with the level generator PS-19 and display unit SG-2/SG-3. Cables K 350 or K 137 serve for the switching over of the automatic level control settling time constant of the Generator (slow auto control settling when the frequencies are lower than 10 kHz). Operation and calibration of the display unit are described in the description and operating manual for the SG-2/SG-3.

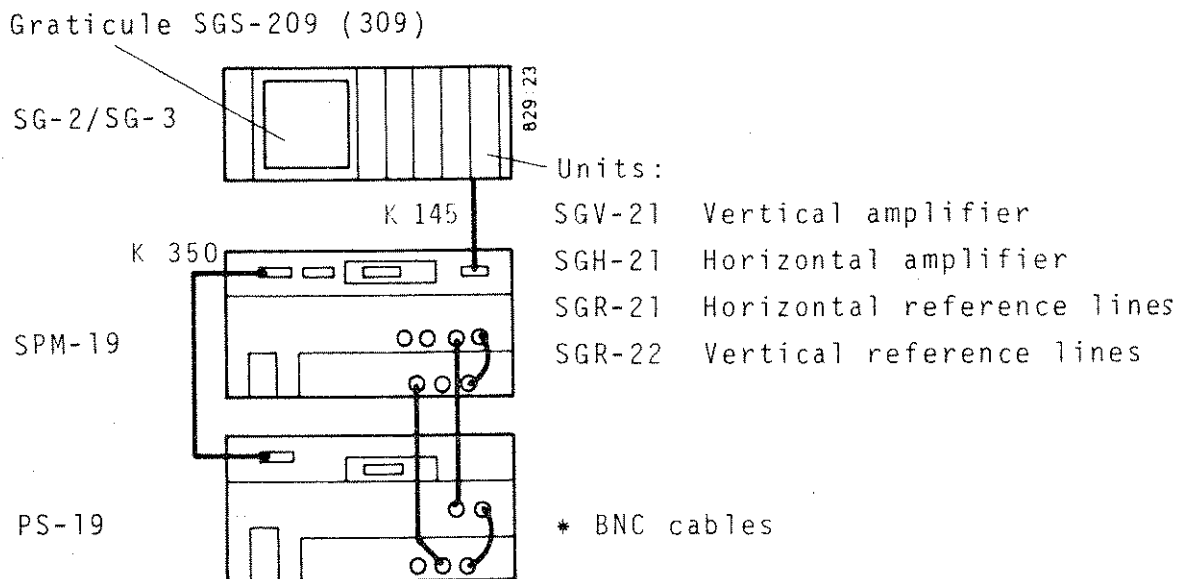

Figure 4-7 Configuration and interconnections of the sweep frequency measuring set-up (rear view)

The frequency is set digitally with an increment which depends on the sweep range and the deflection time. The microcomputer calculates the increment, taking into account that the frequency is stepped every 60 μ s.

4.13.1 SETTING UP THE SWEEP LIMITS

This depends on the application.

For wide-band test objects, it is advantageous to enter

f_{START} = lower (upper) sweep limit and

f_{STOP} = upper (lower) sweep limit.

via the keyboard (see section 4.4.1).

For narrow band test objects,

f_{CENT} = center frequency and

Δf = sweep width ($f_{STOP} - f_{START}$)

are entered (see section 4.4.1).

Example: $f_{CENT} = 10$ MHz, $\Delta f = 10$ kHz

Input: 10 10

After depression of the pushbuttons and , the sweep limits (in this example 9.995 and 10.005 MHz) are displayed in the frequency display D.

Note:

A frequency appearing in the frequency display D and assigned to the pushbutton can be transferred to the memories for the parameters in the input panel if pushbutton is held down and one of the pushbuttons in panel is depressed. A typical application of this is measurement of test objects with extreme resonance points, such as quartz filters. (See also section 4.4.4). In this case the SPM-19 is tuned continuously with pushbutton E to a maximum level indication and sweep frequency operation is then carried out with center frequency and sweep width settings.

4.13.2 SWEEP SEQUENCE AND TIME

The two pushbuttons SWEEP permit selection of

SWEEP  periodic, triangular sequence

SWEEP  single sweep

If the pushbutton whose function is currently active is depressed momentarily during sweep frequency operation, the direction of sweep is reversed.

SWEEP TIME

The time for one sweep can be set in the range between 0.1 and 300 s with SWEEP TIME changeover switch 17 .

In the case of single sweep operation, the starting frequency is selected by depressing one of the pushbuttons f_{START} or f_{STOP} , and the sweep is then started by depressing the pushbutton SWEEP  .

Settling check (settling of the test object) can be carried out either visually (the forward and backward traces of the sweep curve must coincide) or by depressing the pushbutton SWEEP  . In the latter case, the deflection is stopped momentarily at regular intervals. If the test object has not settled correctly, this results in a staircase waveform of the sweep curve and the sweep time should be increased. Depression of the sweep pushbutton is particularly advantageous for slow sweep frequency operations where the persistence of the display unit screen is not sufficient.

4.13.3 MANUAL SWEEP

In the position "MAN" of the SWEEP TIME changeover switch **17**, with one of the two **SWEEP** pushbuttons depressed, the frequency can be swept manually within the limits set as specified in section 4.13.1, using the knob **14**. The X-deflection voltage at output **25** is proportional to the sweep width and its maximum values are ± 2.5 V.

If the manual tuning knob is turned slowly, the frequency changes proportionally; if the knob is turned rapidly, the frequency change is accelerated.

4.13.4 DISPLAY UNIT CONNECTION **42**

The display units SG-2 (screen size 120 mm x 85 mm) and SG-3 (screen size 210 mm x 150 mm) from Wandel & Goltermann are suitable for display of a sweep frequency curve.

The display unit should be connected via a suitable cable (e.g. K 145, see also Figure 4-7) to socket **42** on the rear side of the SPM-19. No further cable connections are necessary.

The X- and the Y-signals for horizontal and vertical deflection of the sweep curve are available at the display unit connector (see Figure 4-8 for pin assignments). The signals are equal to the DC voltages at the Y-output **24** (see section 4.14) and X-output **25** (see section 4.15).



Pin	Signal designation
4	Switch to reference line voltage
5	Pen lift function $H \equiv$ pen up
6	$H \equiv$ pen down
9	X-deflection voltage
10	Y-deflection voltage
12	Blank the measuring line
13	Y-comparison line voltage
14	Ground

Figure 4-8 Pin assignments of the display unit connector 42

The level values of the horizontal reference lines generated within the display unit can be displayed on the SPM-19 meter B via connector 42. Three horizontal reference lines can be set up in the reference line insert SGR-21 for measuring the sweep curve. The brightness of one line can be increased with respect to that of the other two lines by depressing a pushbutton. At the same time, the meter indication of the level meter is switched from the received level to the comparison line level. A black bar and the test "REF.LIN." appear in the bottom left corner of the level display A. The display mode should be taken into account as described in section 4.6.2, when reading the level value.

The pen lift control simplifies operation of plotters connected to socket 42. With suitably equipped plotters with TTL-control (e.g. HP 7015 B), this function ensures that the pen is lifted during setting up of the sweep conditions and is lowered onto the paper only when a single sweep is initiated.

4.14 DC (Y-) OUTPUT [24]

A Y-deflection voltage which is proportional to the meter indication B is available at output [24], for example for driving a plotter. The open circuit voltage is +5 V for full scale deflection of the analog meter, with an internal resistance of 5 k Ω . This DC voltage is also available at the 14-pin socket [42] on the rear of the SPM-19 (see section 4.13.4).

For the calibration of the Y axis of an X-Y recorder, the following is done:

- Test signal or signal from the 10 MHz output [50] is fed into the SPM-19 input
- Measure level in mode ANALOG with the desired scale and store as a reference value (see 4.6.1.2).
- Press pushbutton ABS-REF. Analog reading is 0 dB \cong upper reference point.
- Remove test from input \cong lower reference point

4.15 DC (X-) OUTPUT [25]

The DC (X-) output [25] supplies a deflection voltage which is proportional to the frequency within the frequency limits f_{START} and f_{STOP} , for example for driving a plotter or a display unit.

Regardless of the selected range, the open circuit voltage is

at f_{START} : -2.5 V

at f_{STOP} : +2.5 V

with an internal resistance of 5 k Ω .

This DC voltage is also available at the 14-pin socket [42] on the rear of the SPM-19 (see section 4.13.4).

4.16 10 kHz IF OUTPUT 43

The last intermediate frequency (IF) of 10 kHz can be extracted at the output socket 43 on the rear of the unit. This output is suitable, amongst other things, for connection of plotters with AC inputs and of very selective analyzers.

The output frequency is always 10 kHz, even in wide-band mode.

At meter indication of 0 dB and with an internal impedance of 600 Ohm, the output level is -10 dB when terminated with a 600 Ohm load.

4.17 REMOTE CONTROL OF THE LEVEL GENERATORS PS-18, PS-19, PSS-19

The level meter SPM-19 can be combined with the above-mentioned level generators to form a complete level measuring set.

If the generator and receiver are used at the same location, their frequencies can be tuned synchronously from the SPM-19. This operating mode, in which the level meter controls the level generator, provides considerable simplification of operations. For remote control of the generator from the SPM-19, the control outputs 44 and 50 of the SPM-19 are connected with coaxial cables to the control inputs of the generator. (See Figure 4-7). When this connection is established, the frequency display on the PS-18 or PS-19 is switched off ("external frequency tuning" on) and the two units operate synchronously.

4.17.1 TRACKING GENERATOR OUTPUT (Series D...)

If no level generator is available, then the send signal can be extracted from output [47] for frequency response measurements in range 200 Hz to 25 MHz. Output level is (19 \pm 1) dB at an output impedance of 75 Ω . The output is short circuit proof.

Notes:

1. At operation mode "WIDEBAND" output frequency is 10 kHz during calibration.
2. At operation mode "SELECTIVE" output frequency is 180 Hz at $f \leq 180$ Hz during calibration.
3. At position "48 kHz" of wideband switch output frequency is swept.

4.18 STANDARD FREQUENCY INPUT [51]

If the specified frequency accuracy of the SPM-19 is not sufficient for specific measuring tasks, an external standard frequency of 1, 2, 5, or 10 MHz can be connected to socket [51] on the rear of the unit to achieve a smaller error in the tuned frequency.

The necessary level with a sinusoidal input signal may lie between -20 and 0 dB; for square-wave signals, the voltage V_{pp} may lie between 200 mV and 2 V.

4.19 DIGITAL INTERFACE [40] [41]

The level meter SPM-19 includes a digital, device-specific interface which is available externally via the two 24 pin parallel connection sockets [40] and [41] on the rear of the unit. Additional devices such as the level generators PSS-19 and PS-19 or the Relay Changeover Switch RU-3, BN 323/02 can be connected to these sockets. The connection is always required only for a few specific applications in the case of the PS-19 (see operating instructions for the PS-19). The cable K 350, which is included with the PSS-19, is suitable for connection. Address (2), data (8), and control (3) signals are transmitted across the interface.

4.20 COMPUTER CONTROL

All functions of the level meter SPM-19 can be controlled by an external controller. This makes it possible to include the meter in automatic measuring systems where it can handle comprehensive measuring tasks not only accurately and reliably, but also rapidly and at low costs. Figure 4-9 shows the configuration of a simple automatic level measuring system, which is capable of further extension.

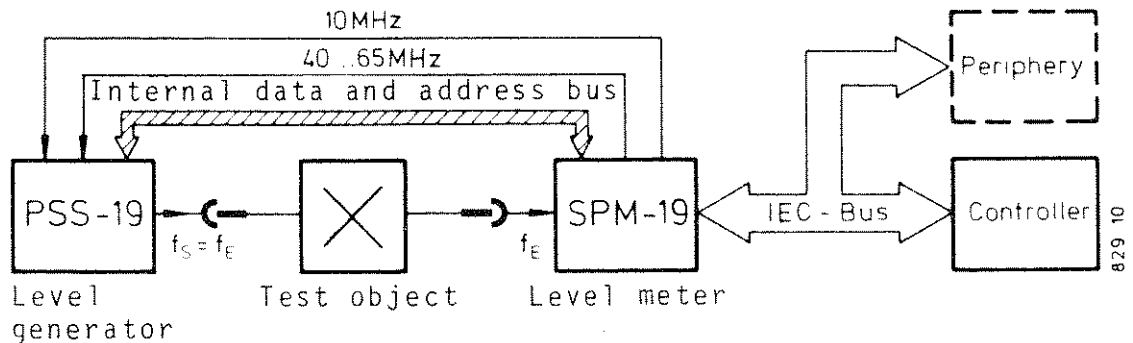

Figure 4-9 Block diagram of a simple automatic level measuring system.

The computer control is connected via the optional **IEC 625** interface board, BN 853/02, which is inserted into the rear of the level meter. Connection to systems with IEEE 488 interfaces is done with adapter plug S 834 delivered with the interface board. Subsequent installation of the interface board is described in chapter 6. The external control of the SPM-19 is signalled by indication of the red LED above pushbutton LOCAL. As long as this LED is on, manual operation via keyboard input is blocked.

It is possible to switch to manual control with the computer connected by depressing the pushbutton **LOCAL**; this is done in accordance with the conditions specified in the IEC bus standard (remote/local function RL1). Details of programming of the level meter can be found in the separate manual "Remote control and programming of the SPM-19".

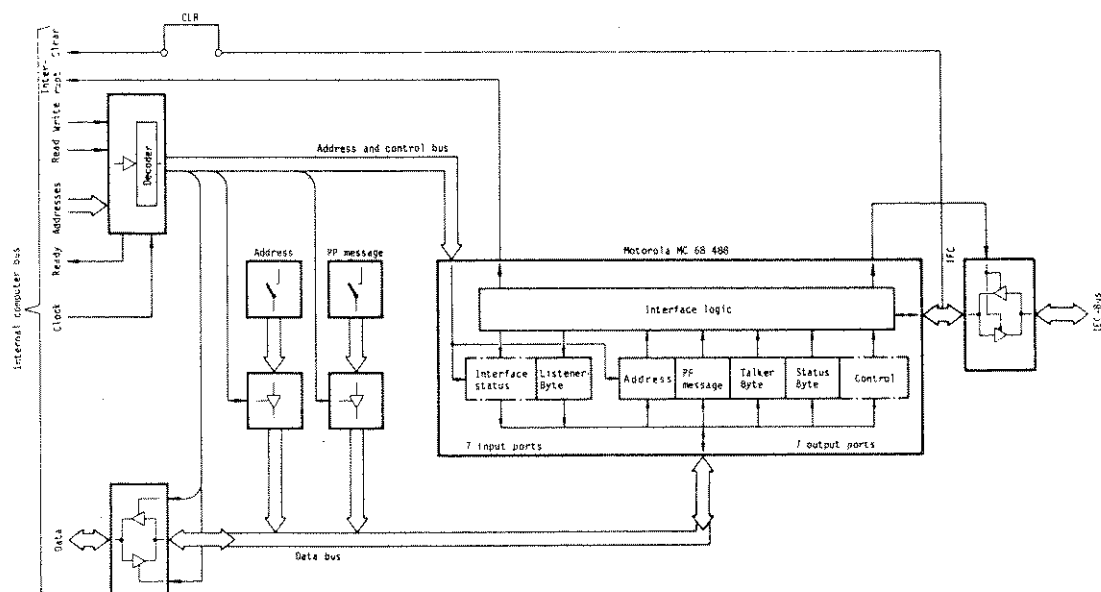

Figure 4-10 Block diagram of the IEC bus interface

Explanation of the Block Diagram

Figure 4-10 shows the simplified block diagram of the IEC 625 Interface. For better understanding of the following description of the Interface concept reference to the "Interface Bus IEC 625" Brochure is recommended. The differences between the IEEE and the IEC Interface are explained in para. 4.20.2.

For the microprocessor, the IEC bus interface is nothing more than a group of input and output ports. Data are exchanged between the IEC bus and the Level Meter via these ports, and the exchange is controlled by the IEC bus program. The PROM's which contain this program are not located on the IEC bus interface board but are within the Level Meter.

The actual interface logic is located in a single integrated circuit: On the one side the interface is connected to the IEC Bus via the required driver and receiver circuits, and on the other side the comb connector is connected to the I/O Bus of the microprocessor within the SPM-19. This interface logic handles a major part of the interface tasks independently, i.e. without using the microprocessor of the Le-

vel Meter. It automatically handles for example the IEC bus handshake cycle and decodes all messages which are transferred across the IEC bus.

The interface statuses resulting from these messages are written into the appropriate input ports.

A further input port is used as a transfer register for listener data, representing data transferred from the IEC bus to the Level Meter as long as the Level Meter is addressed as a listener, for example, when parameters for setting the SPM-19 are being transferred.

The output ports are used for:

- reception of control commands with which the microprocessor can affect the behavior of the interface logic (for example, in addition to a wide range of other possibilities, it can stop the handshake cycle or transmit a service request signal (SRQ) via the IEC bus).

- transferring data which are to be transmitted from the Level Meter to the IEC bus, e.g. talker data and status information. Talker data are transmitted from the Level Meter to the IEC Bus as long as the Level Meter is operating as a talker, for example when the result of measurement is being transferred.

The status information is the Level Meter's response to a serial poll and includes the current status.

The STMS address can be set up on an address switch (see Fig. 6-2).

The "PP" switch (see Fig. 6-2) permits selection of the data circuit to the IEC bus on which the Level Meter is to transmit its Request Service Signal (RQS) if the controller carries out a status request by a parallel poll operation.

4.20.1.1 INTERACTION BETWEEN THE LEVEL METER AND THE IEEE BUS INTERFACE

When the IEC bus has reached a status in which operation by the internal microprocessor is necessary, the IEC bus interface transmits an interrupt signal to the Level Meter. As a result of this interrupt,

the microprocessor then executes the IEC Bus program. This is always the case:

- if the Level Meter is to be switched from manual control (LOCAL) to remote control or from remote control to manual control.
- if listener data were transmitted across the IEC Bus. The interface logic has then written this data into the transfer register for listener data and stopped the handshake procedure. The handshake procedure remains interrupted until the microprocessor reads this byte (then NDAC transits to false i.e. data accepted). After processing and storage of the listener data, NRFD is false i.e. device ready for data can be transmitted.
- if the Level Meter must provide a new talker byte. During writing of the new talker byte into the appropriate output port, the handshake procedure is started (DAV is true i.e. data are valid).
- if a measurement is to be initiated in the Level Meter by the IEC Bus command "device trigger (GET = Group Execute Trigger)". The interface logic has interrupted the handshake procedure and this procedure remains interrupted until the microprocessor has started the measurement and again releases the handshake procedure (NDAC is false and NRFD is false).
- if the Level Meter is to be set to a specified initial status by the IEEE Bus command "device clear (DCL or SDC = Selected Device Clear)". Again, the interface logic interrupts the handshake cycle and it remains interrupted until the microprocessor has set the Level Meter to the initial state, when the handshake cycle is again released (NDAC is false and NRFD is false).

If the strap CLR is fitted on the IEC bus interface board, the IEC bus signal IFC (Interface Clear) causes the Level Meter to be initialized. This permits the Level Meter to be initialized at any time via the IEC bus, even in the case of a lock-up situation. (This is important for devices in unmanned stations where a lock-up situation resulting from external interference cannot be cleared by switching the mains voltage off and on again).

4.20.1.2 Structure of the IEC Bus Program

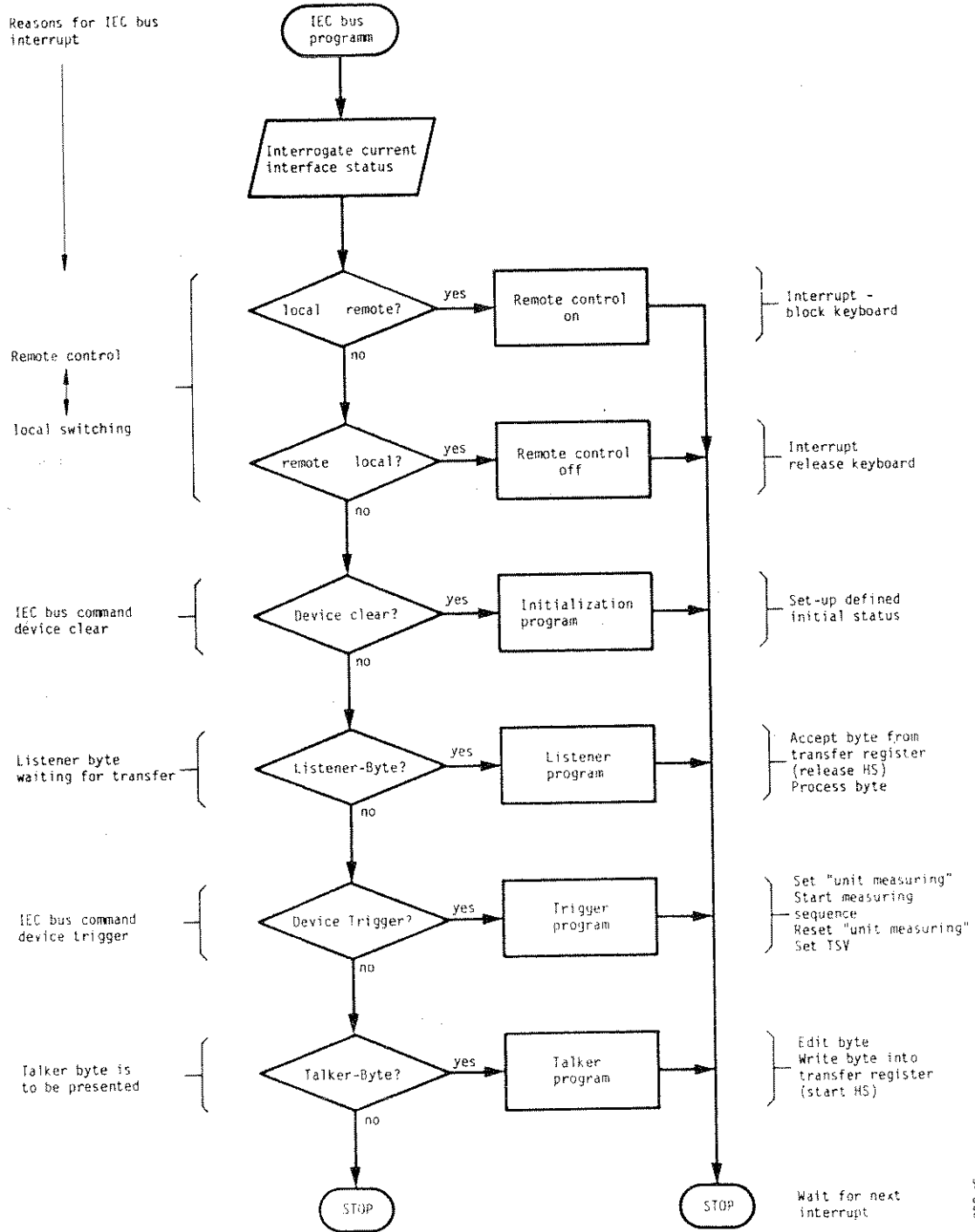

4.20.2 BUS SPECIFICATION AND BUS PLUGS

Up to 15 devices can be connected together in an automatic measuring system which is compatible with the IEC bus. The devices are connected in parallel via the standard interface.

Each single device is connected to the bus via a connection cable with a maximum length of 2 m. The total length of the bus must not exceed 20 m. Greater lengths can be implemented by means of interposed interface couplers (by a two-wire or four-wire connection) or modems.

The ISO 7-bit code or the ASCII code is used on the interface and is transmitted parallel by bit and serial by byte.

The pin assignments of the bus plug on the level meter are shown in Figure 4-11. The most important difference between the IEC 625 and the IEEE 488 interface is in the construction of the plug (IEC: 25 pin cannon plug; IEEE: 24 pin Amphenol plug) and in the pin assignments. However, test equipment with IEC connections can be connected easily to the controllers with IEEE interfaces by using the adapter plug S 834 which is included in the package with the interface board.

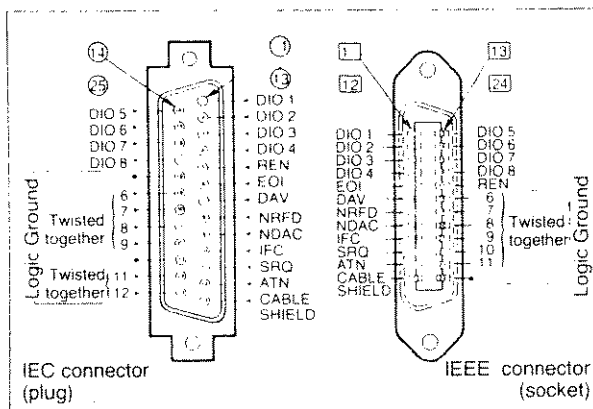

Figure 4-11 Pin assignments of the bus connector on the level meter.

4.21 PRINTER CONNECTION

A printer interface BN 905/01 can be fitted in level meters for recording and documentation of the measured results on a printer. The interface is installed on the rear of the unit, instead of the IEC interface board, as described in chapter 6.

All printers with the CCITT V.24/V.28 interface can be connected. Wandel & Goltermann recommends connection of the printer

TREND 800 R0 8

from the supplementary program. The technical data and the versions of this printer are available in a separate specification.

Initiation of a printer operation can be carried out manually with pushbutton **LOCAL** or automatically after each measurement. The operating modes and the various print formats are selected on the keyboard through entry of a program number. Further details can be found in the operating instructions in section 4.25.3.

4.22 MEMORY FUNCTIONS (MEM)

A number of fixed frequencies and equipment settings can be stored and recalled later with the blue pushbutton MEM. This permits rapid execution of measurements at frequently used frequencies and equipment settings. If the level meter is switched off, or if the mains supply fails, a built-in Ni-Cd battery provides power supplies for the memories, retaining

the data for approximately 4 weeks. If it is necessary to retain the parameters and data for longer periods, the EPROM module BN 829/00.03 Auxiliary Device can be fitted (see section 4.23). This module is programmed in accordance with the customer's specifications. In addition, this module permits simple execution of white noise measurements as the noise power ratio, the reduced noise level, and the reduced noise power can be displayed directly with the measuring program included in the module. For white noise measurements alone instead of this, the favorably priced EPROM BN 829/00.02 can also be used.

4.22.1 ADDRESS ORGANIZATION

Table 4-3 provides an overview of the addressable memory positions (address and program numbers) and their contents. As can be seen from this table, 100 fixed frequencies and 11 complete equipment settings can be programmed as required. The parameters and data are stored in a RAM and are not cleared when the unit is switched off (see section 4.22). They can be overwritten at any time with new entries.

In addition, a maximum of 100 further fixed frequencies and 40 equipment settings can be stored in accordance with the customer's specifications in an EPROM (see section 4.23.1). Numerical inputs of 1000 or greater are interpreted by the level meter as test program numbers for special measuring or operating modes, such as white noise or level difference measurements, test programs, or operating programs for connected printers.

The built-in test programs listed in Table 4-4 are stored at the addresses 111, 112, 115 or 119. When the appropriate address is connected, the currently stored program number appears in the level display A as long as pushbutton is depressed. When the pushbutton is released, the level meter executes the stored test program.

The level meter can be switched back to a normal test program by depressing one of the display pushbuttons (e.g. ABS).

Address	Contents (data)	Remarks
0 ... 99	Fixed frequencies	Freely programmable After initial program load ⁺ : 0 kHz.
100 ... 110	Equipment settings	Freely programmable After initial program load ⁺ : standard set-up.
111	White noise program	} Input via program number as shown in Table 4-4. RU-3, BN 323/02 required for program 112
112	Level difference measurement	
115	Printer programs	
119	Internal test programs	
200 ... 299	Fixed frequencies	Fixed, as specified by customer.
300 ... 339	Equipment settings	Fixed, as specified by customer.

Table 4-3 Address Organization

Program number	Contents
1000 ... 1038	NPR measurement with various systems (see 4.23.2.3)
1100	Measurement of the reduced noise level (see 4.23.2.1)
1200	Measurement of the reduced noise power (see 4.23.2.2)
2012/2021	Measurement of level difference, channel 1 (2) - channel 2 (1) with RU-3, see 4.25.2
5000 ...	Printer programs (see 4.25.3.2)
9001	Standard Setup
9901	Test program, dB calibration
9901	Test program, dBm calibration

Table 4-4 Program Numbers

+) Note: The program number 9000 should be used only when actually required e.g. to clear the fixed frequency RAM, because all addresses 0 to 99 are cleared and all contents of addresses 100 to 110 are loaded with the "standard set-up" as specified in section 3.6. (Initial program load). If the power supply for the RAM from the built-in Ni-Cd battery was interrupted, for example during repair, it is recommended that likewise address 9000 be recalled or the pushbutton T below the upper case cover be depressed. (See also section 3.6 and Figure 6-2).

If an attempt is made to store or recall fixed frequencies or equipment settings at invalid addresses, an error number (e.g. 2--001 $\hat{=}$ invalid address number) appears in the frequency display D. The meanings of the error numbers are shown in Table 6-2.

4.22.2 The Functions Store and Recall

Data and measuring parameters can be stored and recalled as required with the two pushbuttons **STO** and **RCL** on control panel **12** . After entry of the values, the following pushbuttons must be depressed:

Store: **MEM** address number **STO**

The LED above the pushbutton **MEM** blinks as long as the function key **STO** is not depressed. An error number appears if an invalid address is selected (see section 4.22.1).

Recall: **MEM** address number **RCL**

The LED above the pushbutton **MEM** blinks as long as the function pushbutton **RCL** is not depressed. An error number appears if an invalid address is selected (see section 4.22.1). After a successful recall, the MEM function remains active and further addresses can be entered via the keyboard **12** or the addresses can be stepped sequentially by depressing the two STEP direction pushbuttons. Automatic stepping is possible in the address ranges 0 to 99 and 200 to 299.

When the MEM function is active, the selected address number is displayed in the frequency display D as long as the pushbutton **RCL** is depressed.

4.22.3 STORING THE FIXED FREQUENCIES

Number: Up to 100 fixed frequencies

Address range: 0 ... 99 (see Table 4-3).

- Enter the required frequency on the keyboard (see section 4.4.1).
- Depress **MEM** (LED must light).
- Enter the required address on the keyboard **12**
- Depress **STO** .
- Enter the next frequency.

If it is necessary to enter a large number of fixed frequencies in sequential addresses, remembering of the last address which was used can be avoided by using a different input procedure, as described below:

Enter first frequency - **MEM** on - enter starting address - **STO**
MEM on - Step **↑** - **MEM** off -

Enter second frequency - **MEM** on - **STO** - **MEM** on - Step **↑**
etc.

4.22.4 RECALLING SINGLE FIXED FREQUENCIES

from the address ranges 0 ... 99 and 200 ... 299
(with Auxiliary Device BN 829/00.03 only).



- Depress **MEM** .
- Enter the required address (frequency) via the keyboard **12** .
- Depress **RCL** . The required fixed frequency appears in the frequency display.

As the MEM function remains active, further fixed frequencies can be recalled immediately simply by entering the address.

4.22.5 RECALLING A SEQUENCE OF FIXED FREQUENCIES

If measurements are to be carried out with several frequencies which are stored as sequential addresses in the RAM, settings can be simplified considerably by manual or automatic recall.

a) Manual recall

- Select the required starting address (frequency) as described in Section 4.22.4.
- The following fixed frequencies are then selected with the two STEP direction pushbuttons " L ".  
The function MEM remains active. The corresponding address number is displayed if the pushbutton **RCL** is depressed.

b) Automatic recall

In this mode, the start and stop addresses (frequencies) must be specified. Measurement is then always carried out within the preset limits. This mode is used, for example, for selective end-to-end line measurements (see section 4.11).

- Depress **MEM** .
- Depress **f_{START}** and enter the start address on the keyboard **12** .
- Depress **RCL** .
- Depress **f_{STOP}** and enter the stop address via the keyboard **12** .
- Depress **RCL** .
- Set the step time with STEP TIME changeover switch **17** .
- Depress **f_{START}**, **RCL**, (Set to START address)
- Depress **STEP** twice (LED "AUTO" must light)¹⁾.

Measurements are now carried out one time from the START to the STOP addresses. The measurement can be repeated if, in consecutive order, the pushbuttons **f_{START}**, **RCL**, **STEP** (2x) are depressed. Depending on the settings, the frequencies are stepped in ascending or descending order of addresses. If the mains power supply is interrupted and switched on again, the unit switches back to the old operating state.

Switching Off

of this operating mode: depress a function pushbutton such as **f** and depress pushbutton **MEM** .

1) If START and STOP addresses are not in the same memory area (RAM or ROM area), then the error number appears 2--004. This is also displayed when the TRACK mode is switched in.

4.22.6 STORAGE OF EQUIPMENT SETTINGS (SET-UPS)

Number: up to 11 complete front panel set-ups.

Address range: 100 ... 110 (see Table 4-3).

With the exception of the two functions⁺AUTO STEP and TRACK, all functions and parameters which can be selected on the front panel can be stored. Storage and recall is carried out as described in section 4.22.2:

- Input of the required parameters and data.
- Depress (LED must light).
- Select the required memory position (address) on the keyboard .
- Depress .
- Enter the next equipment setting.

⁺ AUTO STEP and TRACK functions are possible if, after recall of the required set-up, the start and stop addresses are entered as described in 4.22.5 b.

4.22.7 RECALL OF EQUIPMENT SETTINGS (SET-UPS)

from the address ranges 100 ... 110 and 300 ... 339 (with BN 829/00.03) is carried out as described in section 4.22.2:

- Depress **MEM** .
- Enter the required address (set-up) on keyboard **12** .
- Depress **RCL** .

As the MEM function remains active, further set-ups can be recalled by simply entering the address or with the aid of the two STEP direction pushbuttons "L" (see section 4.22.5 a and see also note under 4.22.6).

This facility has an interesting application for sweep frequency measurements. With the aid of the STEP direction pushbuttons "L", it is possible to display the overall selectivity and the pass-band of a filter sequentially on the screen of a display unit.

4.23 WHITE NOISE PROGRAM AND PROM BN 829/00.03 (AUXILIARY DEVICE)

The level meter SPM-19 possesses characteristics such as high overdrive resistance, high selectivity with a 1.74 kHz noise bandwidth, and high frequency accuracy and stability which permit noise measurements on communication systems during operation. A wide noise program has been developed to permit simple but precise execution of measurements and display; this program is available as an option at extra cost. It is stored in the C-MOS module BN 829/00.02 (EPROM) and can be added to the level meter at any time as described in section 6.3.3.

It contains data and commands for the calculation operations to be executed, thus reducing the operator activities on the meter to a minimum. The test frequencies, which comply with the recommendations of the CCIT/CCIR and INTELSAT, are either entered via the keyboard **12** or can be stored as the required number (max. 100) and sequence of fixed frequencies, as described in section 4.22.3.

The memory module BN 829/00.03 permits storage of up to 100 fixed frequencies and 40 complete front panel settings. The required frequency values and equipment set-ups should be specified when ordering

option BN 829/00.03 in order to avoid delivery delays (see section 4.23.1). If no details are provided, the MOS module is supplied with only the white noise program, but without fixed frequencies.

4.23.1 FIXED FREQUENCIES AND EQUIPMENT SETTINGS

The fixed frequencies and equipment settings specified by the customer are permanently stored, as shown in Table 4-3, in

Address range 200 ... 299 for fixed frequencies
Address range 300 ... 339 for equipment settings.

They are recalled as described in sections 4.22.2 to 4.22.7. If the EPROM is not fitted in the meter, an error number (e.g. 2--001 $\hat{=}$ invalid address number) would appear in the frequency display D. The meanings of the error numbers are explained in chapter 6.

The ordering forms No. 5/784a for equipment settings (Part I) and/or No. 5/784b for fixed frequencies (Part II) must be filled out completely when ordering the Auxiliary Device. Figures 4-12 and 4-13 show samples of these ordering instructions; column 1 of the ordering instructions for instrument settings contains an example of the entries.

If more than six equipment settings are required, further forms No. 5/784a should be used, and the pages of the form numbered sequentially. Please enter all level and frequency values, even if they are not always required.

WG	SPM-19 Option BN 829/00 03	Bestellvorschrift Ordering instructions	Nr. 1 2 3 4 5 6 7 8 9 0	Blatt Sheet															
Teil I: Part I: Geräteeinstellungen / Instrument settings		Kunde / Customer: _____ Bestell-Nr. / Order No.: _____																	
SPM-19 Nr. AB:																			
geprüft / checked	erstellt (Datum) / completed (date)	T: _____																	
Festfrequenzen / Fixed Frequencies (Teil II / Part II) ja / yes <input type="radio"/> nein / no <input type="radio"/>																			
Gewünschte Einstellungen und Zahlenwerte eintragen. Mit Adressnummer 300 beginnen (Max. bis Adresse 339); bei >6 Setups weitere Vordrucke verwenden. Enter wanted settings and numerical values. Begin with address No. 300 (Max. to address 339); with >6 Setups, use another printed form.																			
Adresse / Address	No	Beispiel / Example																	
Display	Abs <input type="checkbox"/> Ref <input type="checkbox"/>	0	<input type="checkbox"/>	<input type="checkbox"/>	<input type="checkbox"/>	<input type="checkbox"/>	<input type="checkbox"/>	<input type="checkbox"/>	<input type="checkbox"/>										
	(Abs-Ref) <input type="checkbox"/>																		
	dBm0 <input type="checkbox"/> dB <input type="checkbox"/>																		
Mode	Digital <input type="checkbox"/>	4	<input type="checkbox"/>	<input type="checkbox"/>	<input type="checkbox"/>	<input type="checkbox"/>	<input type="checkbox"/>	<input type="checkbox"/>	<input type="checkbox"/>										
(Scale)	Analog: dB <input type="checkbox"/>																		
	20 dB <input type="checkbox"/> 80 dB <input type="checkbox"/>																		
	4: <input type="checkbox"/>																		
Averaging	On <input type="checkbox"/> Off <input type="checkbox"/>	0	<input type="checkbox"/>	<input type="checkbox"/>	<input type="checkbox"/>	<input type="checkbox"/>	<input type="checkbox"/>	<input type="checkbox"/>	<input type="checkbox"/>										
Auto Cal	On <input type="checkbox"/> Off <input type="checkbox"/>	1	<input type="checkbox"/>	<input type="checkbox"/>	<input type="checkbox"/>	<input type="checkbox"/>	<input type="checkbox"/>	<input type="checkbox"/>	<input type="checkbox"/>										
Input	Unbal 75 Ω, v. <input type="checkbox"/> 1	4	<input type="checkbox"/>	<input type="checkbox"/>	<input type="checkbox"/>	<input type="checkbox"/>	<input type="checkbox"/>	<input type="checkbox"/>	<input type="checkbox"/>										
	Bal I 124 Ω, v. <input type="checkbox"/> 2																		
	150 Ω, v. <input type="checkbox"/> 3																		
	Bal II 150 Ω, v. <input type="checkbox"/> 4																		
	600 Ω, v. <input type="checkbox"/> 5																		
Bandwidth	Wide <input type="checkbox"/>	3	<input type="checkbox"/>	<input type="checkbox"/>	<input type="checkbox"/>	<input type="checkbox"/>	<input type="checkbox"/>	<input type="checkbox"/>	<input type="checkbox"/>										
	<input type="checkbox"/> <input type="checkbox"/> <input type="checkbox"/> <input type="checkbox"/> <input type="checkbox"/>																		
	Set: 25, 400, 1740, 3100 Hz, 48 kHz																		
Demod	<input type="checkbox"/> <input type="checkbox"/>		<input type="checkbox"/>	<input type="checkbox"/>	<input type="checkbox"/>	<input type="checkbox"/>	<input type="checkbox"/>	<input type="checkbox"/>	<input type="checkbox"/>										
Phase Jitter	φ <input type="checkbox"/>		<input type="checkbox"/>	<input type="checkbox"/>	<input type="checkbox"/>	<input type="checkbox"/>	<input type="checkbox"/>	<input type="checkbox"/>	<input type="checkbox"/>										
AFC	On <input type="checkbox"/> Off <input type="checkbox"/>	5	<input type="checkbox"/>	<input type="checkbox"/>	<input type="checkbox"/>	<input type="checkbox"/>	<input type="checkbox"/>	<input type="checkbox"/>	<input type="checkbox"/>										
Cont'n	Man Fine <input type="checkbox"/> Coarse <input type="checkbox"/>																		
Search	↑ <input type="checkbox"/> ↓ <input type="checkbox"/>																		
Sweep	↔ <input type="checkbox"/> ↗ <input type="checkbox"/>		<input type="checkbox"/>	<input type="checkbox"/>	<input type="checkbox"/>	<input type="checkbox"/>	<input type="checkbox"/>	<input type="checkbox"/>	<input type="checkbox"/>										
Rate/s	Man <input type="checkbox"/> Opt <input type="checkbox"/>	0,3	<input type="checkbox"/>	<input type="checkbox"/>	<input type="checkbox"/>	<input type="checkbox"/>	<input type="checkbox"/>	<input type="checkbox"/>	<input type="checkbox"/>										
Ref-Wert / Value		0 0 0 0 0 0																	
dBm-Wert / Value		0 0 0 0 0 0																	
Meßbereich / Meas Range		0 1 0 0 0																	
Frequenz / Frequency ¹⁾		MHz	kHz	Hz	MHz	kHz	Hz	MHz	kHz	Hz	MHz	kHz	Hz	MHz	kHz	Hz	MHz	kHz	Hz
f _{START}		1 2 3 4 5 6			1 2 3 4 5 6			1 2 3 4 5 6			1 2 3 4 5 6			1 2 3 4 5 6			1 2 3 4 5 6		
f _{STOP}		6 7 8 9 0 0 0			6 7 8 9 0 0 0			6 7 8 9 0 0 0			6 7 8 9 0 0 0			6 7 8 9 0 0 0			6 7 8 9 0 0 0		
f _{STEP}		1 0 0 0			1 0 0 0			1 0 0 0			1 0 0 0			1 0 0 0			1 0 0 0		
1) Die Funktionen AUTO und TRACK sind nur manuell aufrufbar 2) zusätzlich bei Sweep 5 eintragen 3) Im Suchlauf zusätzlich bei SWEEP 5 (wenn ↔) oder 6 (wenn ↗) eintragen 4) Nur Zahlenwerte eintragen 5) Bei Frequenzabläufen Anfangsfrequenz eintragen 6) Hier stets einen Zahlenwert eintragen, auch wenn Set-up ohne Wortbezeichnung f _{STEP} -Funktion					1) The functions AUTO and TRACK are only callable manually 2) enter additionally with SWEEP 5 3) In SEARCH-SCAN mode, additionally enter with SWEEP 5 (if ↔) or 6 (if ↗) 4) enter numerical values only 5) enter beginning frequency with frequency run 6) here, always enter a numerical value, even when Set-up without sweep- or f _{STEP} -function														

Bild 4-12 Formular Bestell-Nr. 5/784 a/ Fig. 4-12 Ordering Form No. 5/784 a



SPM-19

Option BN 829/00.03

Bestellvorschrift Ordering Instructions

Nr.

--	--	--	--

Blatt
Sheet

Teil I / Part I: Geräteeinstellungen / Instrument settings		Kunde / Customer	Bestell-Nr. / Order No
SPM-19, Nr		AB:	
geprüft / checked	erstellt (Datum) / completed (date)		
		T:	Festfrequenzen / Fixed Frequencies (Teil II / Part II) ja / yes <input type="radio"/> nein / no <input type="radio"/>

Gewünschte Einstellungen und Zahlenwerte eintragen. Mit Adreßnummer 300 beginnen (Max. bis Adresse 339); bei >6 Setups weitere Vordrucke verwenden.
Enter wanted settings and numerical values. Begin with address No. 300 (Max. to address 339); with >6 Setups, use another printed form.

Adresse / Address	No.	Beispiel / Example	1	2	3	4	5	6	7	8	9
Display	Abs <input type="checkbox"/> [0], Ref <input type="checkbox"/> [1] (Abs-Ref) <input type="checkbox"/> [2] dBm0 <input type="checkbox"/> [3], dBr <input type="checkbox"/> [4]	<input type="checkbox"/> [0]	<input type="checkbox"/>	<input type="checkbox"/>	<input type="checkbox"/>	<input type="checkbox"/>	<input type="checkbox"/>	<input type="checkbox"/>	<input type="checkbox"/>	<input type="checkbox"/>	<input type="checkbox"/>
Mode:	Digital <input type="checkbox"/> [1] (Scale) Analog 1 dB <input type="checkbox"/> [0] 20 dB <input type="checkbox"/> [4], 80 dB <input type="checkbox"/> [2] Φ <input type="checkbox"/> [6]	<input type="checkbox"/> [4]	<input type="checkbox"/>	<input type="checkbox"/>	<input type="checkbox"/>	<input type="checkbox"/>	<input type="checkbox"/>	<input type="checkbox"/>	<input type="checkbox"/>	<input type="checkbox"/>	<input type="checkbox"/>
Averaging:	On <input type="checkbox"/> [1], Off <input type="checkbox"/> [0]	<input type="checkbox"/> [0]	<input type="checkbox"/>	<input type="checkbox"/>	<input type="checkbox"/>	<input type="checkbox"/>	<input type="checkbox"/>	<input type="checkbox"/>	<input type="checkbox"/>	<input type="checkbox"/>	<input type="checkbox"/>
Auto Cal:	On <input type="checkbox"/> [0], Off <input type="checkbox"/> [1]	<input type="checkbox"/> [1]	<input type="checkbox"/>	<input type="checkbox"/>	<input type="checkbox"/>	<input type="checkbox"/>	<input type="checkbox"/>	<input type="checkbox"/>	<input type="checkbox"/>	<input type="checkbox"/>	<input type="checkbox"/>
Input	Unbal. 75 Ω , \times <input type="checkbox"/> [0], <input type="checkbox"/> [1] Bal. I 124 Ω , \times <input type="checkbox"/> [2], <input type="checkbox"/> [3] 150 Ω , \times <input type="checkbox"/> [4], <input type="checkbox"/> [5] Bal. II 150 Ω , \times <input type="checkbox"/> [6], <input type="checkbox"/> [7] 600 Ω , \times <input type="checkbox"/> [8], <input type="checkbox"/> [9]	<input type="checkbox"/> [4]	<input type="checkbox"/>	<input type="checkbox"/>	<input type="checkbox"/>	<input type="checkbox"/>	<input type="checkbox"/>	<input type="checkbox"/>	<input type="checkbox"/>	<input type="checkbox"/>	<input type="checkbox"/>
Bandwidth	Wide <input type="checkbox"/> [0] <input type="checkbox"/> [1] <input type="checkbox"/> [2] <input type="checkbox"/> [3] <input type="checkbox"/> [4] <input type="checkbox"/> [5] Sel 25, 400, 1740, 3100 Hz, 48 kHz Demod <input type="checkbox"/> [6], <input type="checkbox"/> [7] Phase Jitter Φ <input type="checkbox"/> [8]	<input type="checkbox"/> [3]	<input type="checkbox"/>	<input type="checkbox"/>	<input type="checkbox"/>	<input type="checkbox"/>	<input type="checkbox"/>	<input type="checkbox"/>	<input type="checkbox"/>	<input type="checkbox"/>	<input type="checkbox"/>
AFC:	On <input type="checkbox"/> [7], Off	<input type="checkbox"/> [5]	<input type="checkbox"/>	<input type="checkbox"/>	<input type="checkbox"/>	<input type="checkbox"/>	<input type="checkbox"/>	<input type="checkbox"/>	<input type="checkbox"/>	<input type="checkbox"/>	<input type="checkbox"/>
Contin	Man Fine <input type="checkbox"/> [0], Coarse <input type="checkbox"/> [1]	<input type="checkbox"/> [5]	<input type="checkbox"/>	<input type="checkbox"/>	<input type="checkbox"/>	<input type="checkbox"/>	<input type="checkbox"/>	<input type="checkbox"/>	<input type="checkbox"/>	<input type="checkbox"/>	<input type="checkbox"/>
Search	<input type="checkbox"/> [2] <input type="checkbox"/> [3]	<input type="checkbox"/> [5]	<input type="checkbox"/>	<input type="checkbox"/>	<input type="checkbox"/>	<input type="checkbox"/>	<input type="checkbox"/>	<input type="checkbox"/>	<input type="checkbox"/>	<input type="checkbox"/>	<input type="checkbox"/>
Sweep	<input type="checkbox"/> [5] <input type="checkbox"/> [6]	<input type="checkbox"/> [5]	<input type="checkbox"/>	<input type="checkbox"/>	<input type="checkbox"/>	<input type="checkbox"/>	<input type="checkbox"/>	<input type="checkbox"/>	<input type="checkbox"/>	<input type="checkbox"/>	<input type="checkbox"/>
Rate/s	Man ²⁾ <input type="checkbox"/> [0], Opt ²⁾ <input type="checkbox"/> [9]	<input type="checkbox"/> [0,3]	<input type="checkbox"/>	<input type="checkbox"/>	<input type="checkbox"/>	<input type="checkbox"/>	<input type="checkbox"/>	<input type="checkbox"/>	<input type="checkbox"/>	<input type="checkbox"/>	<input type="checkbox"/>
Ref-Wert / Value		<input type="checkbox"/> [0] <input type="checkbox"/> [0] <input type="checkbox"/> [0] <input type="checkbox"/> [0] <input type="checkbox"/> [0]	<input type="checkbox"/>	<input type="checkbox"/>	<input type="checkbox"/>	<input type="checkbox"/>	<input type="checkbox"/>	<input type="checkbox"/>	<input type="checkbox"/>	<input type="checkbox"/>	<input type="checkbox"/>
dBr-Wert / Value		<input type="checkbox"/> [0] <input type="checkbox"/> [0] <input type="checkbox"/> [0] <input type="checkbox"/> [0] <input type="checkbox"/> [0]	<input type="checkbox"/>	<input type="checkbox"/>	<input type="checkbox"/>	<input type="checkbox"/>	<input type="checkbox"/>	<input type="checkbox"/>	<input type="checkbox"/>	<input type="checkbox"/>	<input type="checkbox"/>
Meßbereich / Meas. Range		<input type="checkbox"/> [0] <input type="checkbox"/> [1] <input type="checkbox"/> [0] <input type="checkbox"/> [0] <input type="checkbox"/> [0]	<input type="checkbox"/>	<input type="checkbox"/>	<input type="checkbox"/>	<input type="checkbox"/>	<input type="checkbox"/>	<input type="checkbox"/>	<input type="checkbox"/>	<input type="checkbox"/>	<input type="checkbox"/>
Frequenz / Frequency f ⁵⁾			<input type="checkbox"/>	<input type="checkbox"/>	<input type="checkbox"/>	<input type="checkbox"/>	<input type="checkbox"/>	<input type="checkbox"/>	<input type="checkbox"/>	<input type="checkbox"/>	<input type="checkbox"/>
f _{START}			<input type="checkbox"/>	<input type="checkbox"/>	<input type="checkbox"/>	<input type="checkbox"/>	<input type="checkbox"/>	<input type="checkbox"/>	<input type="checkbox"/>	<input type="checkbox"/>	<input type="checkbox"/>
f _{STOP}			<input type="checkbox"/>	<input type="checkbox"/>	<input type="checkbox"/>	<input type="checkbox"/>	<input type="checkbox"/>	<input type="checkbox"/>	<input type="checkbox"/>	<input type="checkbox"/>	<input type="checkbox"/>
f _{STEP}			<input type="checkbox"/>	<input type="checkbox"/>	<input type="checkbox"/>	<input type="checkbox"/>	<input type="checkbox"/>	<input type="checkbox"/>	<input type="checkbox"/>	<input type="checkbox"/>	<input type="checkbox"/>

- | | |
|--|---|
| <p>1) Die Funktionen AUTO und TRACK sind nur manuell aufrufbar</p> <p>2) zusätzlich bei Sweep 5 eintragen</p> <p>3) Im Suchlauf zusätzlich bei SWEEP 5 (wenn \times) oder 6 (wenn \swarrow) eintragen</p> <p>4) Nur Zahlenwerte eintragen</p> <p>5) Bei Frequenzablaufen Anfangsfrequenz eintragen</p> <p>6) Hier stets einen Zahlenwert eintragen, auch wenn Set-up ohne Wobbel- oder f_{STEP}-Funktion</p> | <p>1) The functions AUTO and TRACK are only callable manually</p> <p>2) enter additionally with SWEEP 5</p> <p>3) in SEARCH-SCAN mode, additionally enter with SWEEP 5 (if \times) or 6 (if \swarrow)</p> <p>4) enter numerical values only</p> <p>5) enter beginning frequency with frequency run</p> <p>6) here, always enter a numerical value, even when Set-up without sweep- or f_{STEP}-function</p> |
|--|---|



SPM-19

Option BN 829/00.03

**Bestellvorschrift
Ordering Instructions**

Nr.

--	--	--	--	--	--	--	--

Teil II / Part II Festfrequenzen / Fixed Frequencies

Kunde / Customer

Bestell-Nr. / Order No

SPM-19 No.

AB:

geprüft
checked

erstellt (Datum)
completed (date)

T:

Gerateinstellungen / Set-ups (Teil I / Part I) ja / yes nein / no



Gewünschte Testfrequenzen in Hz eintragen. Adressbereich 200-299 / Enter wanted fixed frequencies in Hz. Address area 200-299

MEM	MHz				kHz				MEM	MHz				kHz																									
	1	2	3	4	5	6	7	8		1	2	3	4	5	6	7	8																						
200									235									270																					
201									236										271																				
202									237										272																				
203									238										273																				
204									239										274																				
205									240										275																				
206									241										276																				
207									242										277																				
208									243										278																				
209									244										279																				
210									245										280																				
211									246										281																				
212									247										282																				
213									248										283																				
214									249										284																				
215									250										285																				
216									251										286																				
217									252										287																				
218									253										288																				
219									254										289																				
220									255										290																				
221									256										291																				
222									257										292																				
223									258										293																				
224									259										294																				
225									260										295																				
226									261										296																				
227									262										297																				
228									163										298																				
229									264										299																				
230									265																														
231									266																														
232									267																														
233									268																														
234									269																														

5. 7842

Aussteller bitte nur die stark umrandeten Felder vollständig ausfüllen

Orderer: Please fill out completely within thickly drawn frames

		SPM-19 Option BN 829/00 03		Bestellvorschrift Ordering Instructions				Nr. 			
		Teil II / Part II: Festfrequenzen / Fixed Frequencies				Kunde / Customer				Bestell-Nr. / Order No.	
SPM-19 No.:		AB:		T:				Geräteeinstellungen / Set-ups (Teil I / Part I) ja / yes <input type="radio"/> nein / no <input type="radio"/>			
geprüft / checked	erstellt (Datum) / completed (date)										
Gewünschte Testfrequenzen in Hz eintragen. Adressbereich 200 - 299 / Enter wanted fixed frequencies in Hz. Address area 200 - 299											
MEM	MHz	kHz	Hz	MEM	MHz	kHz	Hz	MEM	MHz	kHz	Hz
z. B. / e. B.	1	2	3	4	5	6	7	8			
200				235				270			
201				236				271			
202				237				272			
203				238				273			
204				239				274			
205				240				275			
206				241				276			
207				242				277			
208				243				278			
209				244				279			
210				245				280			
211				246				281			
212				247				282			
213				248				283			
214				249				284			
215				250				285			
216				251				286			
217				252				287			
218				253				288			
219				254				289			
220				255				290			
221				256				291			
222				257				292			
223				258				293			
224				259				294			
225				260				295			
226				261				296			
227				262				297			
228				263				298			
229				264				299			
230				265							
231				266							
232				267							
233				268							
234				269							

5/784b

Bild 4-13 Formular Bestell-Nr. 5/784b/ Fig. 4-13 Ordering Form No. 5/784b

4.23.2 NOISE MEASUREMENTS

The level meter SPM-19 is characterised by a high intrinsic NPR value. This is determined by a low thermal noise and distortion noise resulting from non-linearities in the preamplifier and mixer and by a low sideband noise from the carrier oscillator. The high intrinsic NPR value and the above-mentioned characteristics of the level meter make it suitable for use as a white noise receiver for checking the quality of a radio link or multi-channel cable transmission system (Figure 4-14). An advantage of this level meter, in contrast to a normal white noise measuring set-up, is that it is not necessary to stop operation on the system for measurement.

A suitable parameter is the signal-to-noise ratio, which can be measured in an unused telephone channel. If the transmission system contains non-linear transmission characteristics (which is normally always the case), then a noise, also called intermodulation noise, results from the input signal (speech load). This noise occurs in the gap of the unused telephone channel, which also contains a basic noise resulting mainly from thermal noise effects.

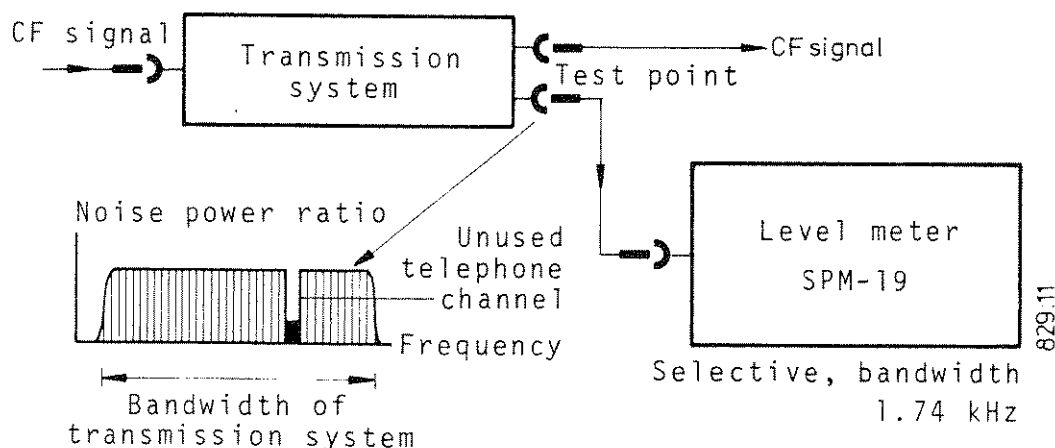

Figure 4-14 Noise measurements with the level meter SPM-19 in an unused channel of a communications system actually carrying traffic.

The following parameters can be determined in order to assess the quality of a transmission system:

- Reduced noise level in dBmOp ($\cong -S/N$)
- Reduced noise power in pWOp
- Noise power ratio NPR

These measurements can be carried out with the Auxiliary Device BN 829/00.02 or BN 829/00.03, with digital display of the results and direct indication of the noise in dBmOp or pWOp. In addition to selective noise measurement, wide-band measurement of the system load is also possible. The settings on the level meter for determining the various parameters are described in the following sections.

4.23.2.1 Measurement of the Reduced Noise Level

Program number: 1100 (see Table 4-4).

Measurement of the noise level p_N is carried out in an unused 3.1 kHz wide telephone channel in active transmission system, using the 1.74 kHz bandwidth of the level meter. This bandwidth corresponds to the psophometrically weighted telephone channel. The noise level p_N is referred to the relative level (dBr) of the system connection and displayed as a reduced noise level p_N^* in dBmOp.

The following relationship applies:

$$\frac{\text{Reduced level } p_N^*}{\text{dBmOp}} = \frac{\text{Noise level } p_N}{\text{dBmp}} - \frac{\text{Relative level } p_r}{\text{dBr}}$$

Settings on the level meter SPM-19:

- Select the required input and impedance with switch **15**.
- Set the relative level (dBr) to the value of the connection point (see section 4.6.1.3).
- **MEM** 1100 **RCL**
- Depress pushbutton **MEM** (LED off)
- Enter the test frequency via the keyboard **12** (see section 4.4.1) or recall it from the stored fixed frequencies (see section 4.22.4).
- If the indication fluctuates, depress the pushbutton **AVRG** (LED on).
- The bandwidth and digital mode are set automatically by the level meter.

This measurement also directly provides the signal-to-noise ratio S/N, as the following relationship is valid:

$$\frac{S/N}{dB} = \frac{P_r}{dBr} - \frac{P_N}{dBmp}$$

The level meter can be switched back to the normal level measuring program by depressing one of the measuring mode pushbuttons (e.g. **ABS**) on panel **3**.

The minimum noise level which can be measured with the SPM-19 is 7 dB above the intrinsic noise level of -73 dBmOp \approx 50 pWOp (see section 4.23.3).

4.23.2.2 Measurement of the Reduced Noise Power

Program number: 1200 (see Table 4-4).

The reduced noise power p^* in pWOp is the psophometrically weighted noise power measured in a gap of the transmission band, referred to the relative level zero (dBr).

The following relationship exists between the noise power and the noise level:

$$1 \text{ pWOp} \cong -90 \text{ dBmOp}$$

The setting of the level meter and execution of the measurement are carried out as described in section 4.23.2.1.

The test program is stored under program number 1200 and is recalled as follows:

MEM 1200 RCL

The test frequency is then entered on the keyboard 12 (see section 4.4.1) or recalled from the memory (see section 4.22.4). The bandwidth and the digital mode are set automatically by the level meter.

The result of measurement is displayed in pWOp in the following form:

$4.5 \cdot 10^{-2}$ pWOp = $4.5 \cdot 10^{-2} \text{ pWOp}$
(Example)

4.23.2.3 Measurement of the Noise Power Ratio NPR

Program numbers: 1000 to 1038 (see Table 4-4).

The NPR value is defined by the ratio between the noise powers p_δ and P_N , which occur in the gap (Figure 4-15). The gap, in this case, is the psophometrically weighted telephone channel with a width $B_{\text{eff}} = 1.74$ kHz.

The following relationships apply:

$$\frac{\text{NPR}}{\text{dB}} = 10 \lg \frac{p_\delta}{P_N} \quad \text{or} \quad \frac{\text{NPR}}{\text{dB}} = \frac{p_\delta}{\text{dBmp}} - \frac{P_N}{\text{dBmp}}$$

The following formulae apply to the noise power p_δ which fills the 1.74 kHz wide gap as shown in Figure 4-15,

$$p_\delta = \frac{P_\Sigma}{B} \cdot 1.74 \text{ kHz}$$

or, for the noise level

$$\frac{p_\delta}{\text{dBmp}} = \frac{P_\Sigma}{\text{dBm}} - 10 \lg \left(\frac{B}{1.74 \text{ kHz}} \right)$$

- P_Σ = total power of the active transmission band
- P_Σ = total level
- B = bandwidth of the transmission system

The noise power P_N or the measured noise level p_N are determined by the basic and distortion noise occurring in the 1.74 kHz wide gap.

For a bandwidth B of the transmission system, the following is thus true:

$$\frac{\text{NPR}}{\text{dB}} = \frac{p_{\Sigma}}{\text{dBm}} - 10 \lg \left(\frac{B}{1.74 \text{ kHz}} \right) - \frac{P_N}{\text{dBmp}}$$

Total level p_{Σ} of the active transmission band.

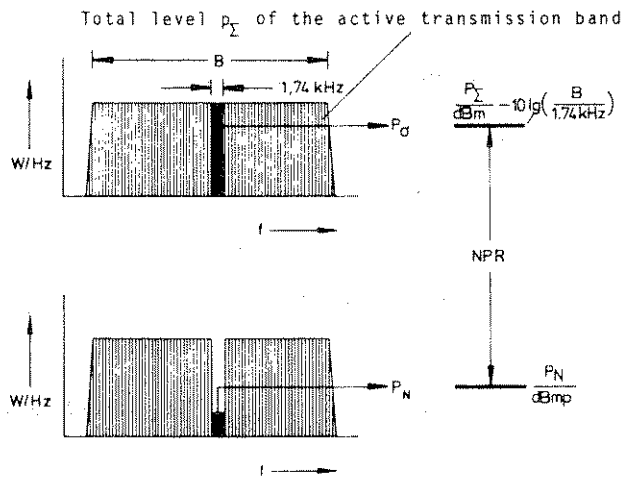

Figure 4-15 NPR value if all telephone channels are uniformly loaded.

The definition of the NPR value makes it clear that the noise power ratio can be determined from a wide-band level measurement (p_{Σ}) and selective level measurement (p_N), taking into account the correction value $10 \lg \frac{B}{1.74 \text{ kHz}}$. This correction value is dependent only on the bandwidth of the system and is shown in Table 4-5, which contains the most important transmission systems. A program number is assigned to each system and is used to select the appropriate test program for the NPR measurement. Except for input of the test frequency, no further settings are required on the level meter. The

white noise program in the Auxiliary Device is implemented, from the software point of view, such that the above-mentioned single measurements, including storage of the measured values and corrections, are carried out automatically by the level meter.

The NPR measurement is carried out as follows:

- Select the required input and impedance with switch **15**.
- Depress **MEM** (LED on).
- Select the program number from Table 4-5 for the system to be measured and enter it on the numerical keypad.
- Depress **RCL** and then switch off **MEM** again (LED off).
- Enter the test frequency on the numerical keypad (see section 4.4.1) or recall it from the fixed frequency memory (see section 4.22.4).
- If the indication fluctuates, depress the pushbutton **AVRG** (LED on).

The bandwidth and the digital operating mode are selected automatically by the level meter, which means that the measured value can be read off immediately after entering the test frequency.

If the function **MEM** is switched on and address 111 recalled by depressing the pushbutton **RCL**, the program number of the active white noise program is displayed in level display A as long as pushbutton **RCL** is depressed.

Invalid addresses are indicated by error number 2--001 (see also Table 6-2).

The level meter can be switched back to the normal level measuring program by depressing one of the measuring mode pushbuttons (e.g. ABS) on panel 3 .

4.23.3 LIMITS OF NOISE MEASUREMENT

From the equations in section 4.23.2.3, it is possible to derive the following relationship:

$$\frac{-P_N^*}{\text{dBmOp}} = \frac{\text{NPR}}{\text{dB}} + 10 \lg \frac{B}{1.74 \text{ kHz}} - \frac{p_{\Sigma,c}^*}{\text{dBmO}}$$

where B is the base bandwidth of the transmission system and $p_{\Sigma,c}^*$ is the conventional system load in dBmO. With the aid of this relationship, it is possible to determine the minimum noise level which can be measured, which corresponds to the signal-to-noise ratio. The expression $10 \lg \frac{B}{1.74 \text{ kHz}} - p_{\Sigma,c}^*$ is a system parameter which changes only slightly for systems with 300 or more speech channels N. At the conventional load $p_{\Sigma,c}^* = -15 + 10 \lg N$, approximately 19 dB.

As indicated by the specifications, the level meter SPM-19 is characterised by a very high intrinsic NPR value of approximately 60 dB (total level $\leq +10$ dBm with a noise bandwidth 0.3 to 12 MHz).

With this information and a displacement of 7 dB of the measured noise level from the intrinsic noise level (measuring error 1 dB), the minimum noise level which can be measured is -73 dBmOp (measured value + measuring error), corresponding to a noise power of 50 pWOp.

The dynamic range, which can be regarded as the level difference between the wide-band total level and the noise level in the 1.74 kHz gap, is

$$p_{\Sigma} - p_N = \text{NPR} + 10 \lg \frac{B}{1.74 \text{ kHz}}$$

and is approximately 100 dB for a transmission bandwidth of 12 MHz.

Program number	Number of system channels	Bandwidth B kHz	Level reduction/dB $10 \log \frac{B}{1.74 \text{ kHz}}$
1000	12	48	14.41
1001	24	96	17.42
1002	36	144	19.18
1003	48	192	29.43
1004	60	240	21.40
1005	72	288	22.19
1006	80	240	21.40
1007	96	396	23.57
1008	120	492	24.51
1009	132	540	24.92
1010	192	792	26.58
1011	240	992	27.56
1012	252	1040	27.76
1013	300	1232	28.50
1014	312	1284	28.68
1015	432	1784	30.11
1016	480	1980	30.56
1017	540	2284	31.18
1018	600	2540	31.64
1019	612	2588	31.72
1020	792	3272	32.74
1021	900	3828	33.42
1022	960	4040	33.66
1023	972	4088	33.71
1024	1092	4880	34.48
1025	1200	5284	34.82
1026	1260	5540	35.05
1027	1332	5872	35.28
1028	1380	5700	35.15
1029	1500	6968	36.03
1030	1800	7844	36.54
1031	1872	8148	36.71
1032	2100	9848	37.53
1033	2400	11088	38.04
1034	2580	10652	37.87
1035	2700	12044	38.40
1036	3600	17000	39.90
1037	10800	55230	45.02
1038	12000	61656	45.49

Table 4-5 Program numbers for NPR measurement

4.24 MEASURING ACCESSORIES

4.24.1 TEST PROBE TK-11

The test probe TK-11 is designed for high impedance and low capacitance extraction of the test signal from test objects with coaxial connections. The test probe is connected to input socket **19** (measured signal) and the test probe socket **18** (power supply).

As soon as a plug is inserted in socket **18**, the basic 10 dB attenuation of the test probe is compensated by a corresponding sensitivity increase within the level meter.

In the most sensitive measuring range of -120 dB or -110 dBm (analog mode), the range indication switches to -110 dB or -100 dBm.

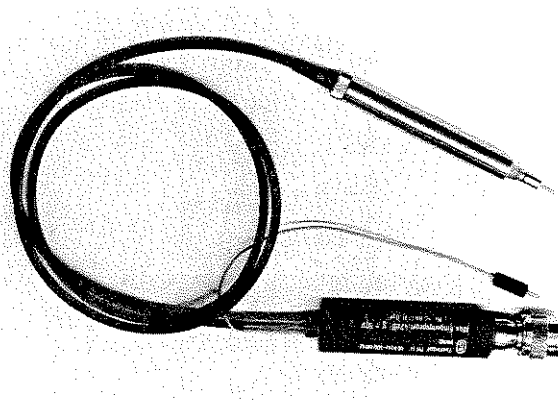

Figure 4-16 Test probe TK-11

The test prod shown in Figure 4-16 can be replaced by a coaxial socket element S 222 of the Versacon[®] 9 system.

Adapters for all common connection systems can then be screwed into this element. Use of the Versacon element increases the input capacitance of 3.5 pF specified in section 1.12.1 by a value which varies according to the type of connector.

The maximum permissible input level of the TK-11 is +10 dBm or +2 dB; any superimposed DC voltage must not exceed 50 V.

4.24.2 TEST PROBE TK-12

The test probe TK-12 is suitable for high impedance, low capacitance level measurements on coaxial and balanced test objects in the frequency range 200 Hz to 18.6 MHz (coaxial) or 200 Hz to 2 MHz (balanced). The active test probe has a gain of 1. It is characterised by a small frequency response error, low intrinsic noise, and high signal balance ratio and common mode rejection. The power supply is provided by the power supply unit TKN-12, which also carries out matching to the coaxial input socket [19] of the SPM-19. The switch [15] must be in position "high impedance"

For coaxial measurements, the universal conversion system Versacon[®] 9 (see chapter 6) permits the use of all common plug systems. In addition, a test prod with ground clip is available for measurement within modules. The screw-on plug S 804 is available at extra cost for balanced measurements.

4.24.3 ADAPTER FEDA-1 (75 Ohms/50 Ohms)

The internal impedance of the generator output or the input impedance of the receiver input can be matched to an impedance of 50 Ohms with the adapter 75 Ohms/50 Ohms. The available socket adapters are listed in section 1.12.4.

If a 75 Ohm cable is used as a test lead, then the adapter should be inserted at the end close to the object being tested (see Figure 4-17). If a 50 Ohm cable is used, it should be fitted on the level meter inside.

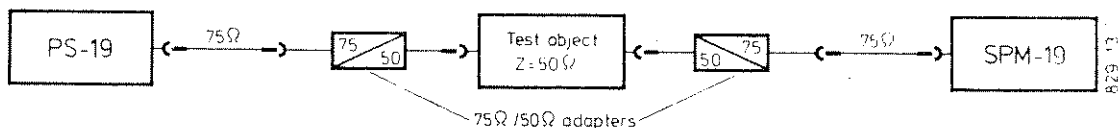

Figure 4-17 Measuring at an impedance of 50 Ohms.

When setting up the generator output level or when reading the level indicated on the receiver, the attenuation (6 dB) of the adapter must be taken into account. With the combination PS-19/SPM-19, this can be done very easily by transferring the attenuation value to the memory for the reference level (dBr) (see sections 4.6.1.2 to 4.6.1.3). The error limits of the level generator and level meter listed in the specifications may be increased by attenuation and frequency response errors and by the reflection factor of the adapter.

4.24.4 REFLECTION AND SIGNAL BALANCE RATIO MEASUREMENTS

Various measuring adapters are available for these measurements:

Reflection measuring unit RFZ-5, 10 kHz to 36 MHz
(see description and operating instructions, RFZ-5).

Reflection factor measuring bridge RFZ-14, 100 kHz to 100 MHz.

Reflection loss measuring adapter RFZ-12, 200 Hz to 4.5 MHz.

Signal balance ratio measuring adapter SDZ-12, 200 Hz to 4.5 MHz. (See description and operating instructions, RFZ-12/SDZ-12).

4.24.4.1 Reflection Loss Measuring Adapter RFZ-14

The measuring bridge RFZ-14 permits measurement and sweeping (SPM-19, BN 829/02 only) of the frequency dependent reflection loss on CF transmission systems or single modules. Together with a suitable generator and receiver such as PS-18, PS-19, PSS-19 (generator) and SPM-18, SPM-19 (receiver), such measurements can be carried out in the frequency range 100 kHz to 25 MHz. The reference impedance is 75 Ohms. The interchangeable socket inserts can be adapted to all common connection systems (see also chapter 6).

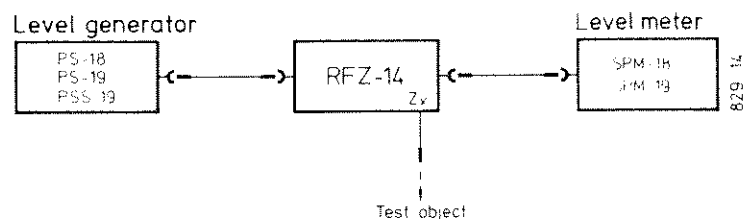

Figure 4-18 Connection of the measuring bridge RFZ-14 to the level measuring set-up.

The measuring adapter is connected to the generator output and the receiver input with 75 Ohm cables, as shown in Figure 4-18. The generator output level should be as high as possible, but should not exceed the maximum permissible level at the input to the object being tested by more than 6 dB (overload limit).

The test configuration is calibrated at the required test frequency or, in the case of sweep operation, within the sweep range. For this purpose, the bridge must be disconnected from the object to be tested, resulting in a reflection factor $r = 1$ or a reflection loss $a_r = 0$ dB. The voltage-linear display is selected on the level meter SPM-19 with the 20 dB pushbutton **10**. If major variations of the reflection loss are to be expected, for example in sweep mode, then the level-linear 80 dB display is better. The value displayed on the meter B corresponds to the reflection loss $a_r = 0$ dB. It is recommended to adjust this value to 0 dB on the meter scale by changing the measuring range setting **9** on the SPM-19 and the output level of the generator.

After connection of the object to be tested, its reflection loss results in a different level from that previously displayed. The measuring bridge is connected directly to the object to be tested in order to avoid additional measuring errors resulting from long cables, possibly with inaccurate characteristic impedances (75 Ohm).

Example:

Indicated level on receiver for
calibration and after correction
of the generator level (reference
value).....-20 dBm

Indicated level with object to be tested connected to RFZ-14 (measured value).....-46 dBm

Reflection loss (reference value minus measured value)..... 26 dB

Corresponding reflection factor..... 5 %

4.25 SPECIAL MODES OF OPERATION

4.25.1 MEASUREMENTS WITH FREQUENCY OFFSET

In the conjunction with Level Generator PS-19, selective measurements can be made while the send and receive frequencies are different. Because automatic frequency sweep is also settable, that type of measurement is greatly simplified on group translators for instance.

The following modes are possible:

1. Synchronous manual frequency stepping (Single Step)
2. Synchronous automatic frequency stepping (Auto Step)
3. Synchronous sweeping
(only with SPM-19, BN 829/02 and PS-19, BN 870/02).

The Cabling of the Measuring Setup and the required instrument settings as well as the operation are described in the Operating Manual of Level Generator PS-19.

When modes AUTO STEP and SWEEP are being used attention should be paid to prevent inadvertent actuation of the push buttons, so that the synchronized condition is maintained.

4.25.2 LEVEL DIFFERENCE MEASUREMENT

Although with the level difference measurement in the mode ABS-REF (see para 4.6.1.2) the measuring level is referred to a fixed, prior stored reference level, the method described in this paragraph forms the level difference from two measurements between the system under test and the reference system. By this means, attenuation and gain measurements on unbalanced systems under test can be implemented with high relative accuracy and excellent reproducibility.

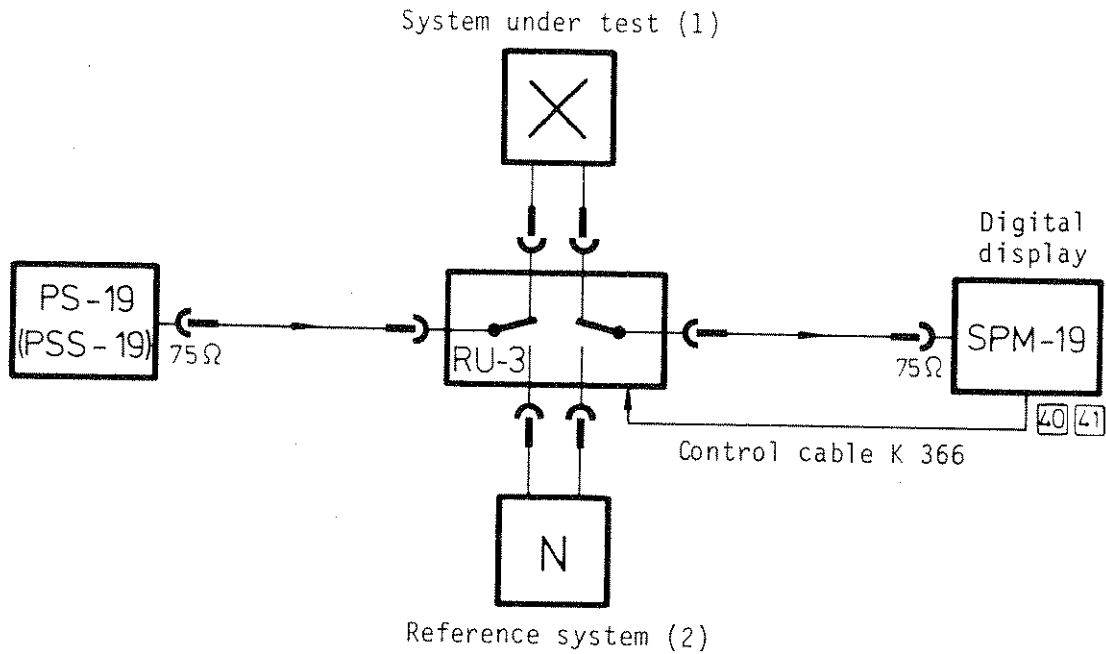

829 24

Fig. 4-19 Level Difference Measurement

In the measuring arrangement of Fig. 4-19 the Generator signal is fed to the Relay Changeover Switch RU-3, BN 323/02. This Changeover Switch contains a digital interface connected to Level Meter SPM-19 by a control cable, K 366 (or K 137). According to the chosen test program the level on the system under test (1) or the reference system (2) is measured digitally, stored, and after automatic changeover of the level value, ascertained in the other measuring branch.

The Relay Changeover Switch RU-3 is outstanding because of the high isolation between the two channels and a very small difference in insertion loss. Thereupon employment of short connecting cables ($l \cong 75$ cm) to the system under test permits attaining high accuracy.

When measurements involve low absolute levels or great differences of attenuation, only double shielded connecting cable should be used (see also para 5.2).

Settings on Level Meter:

- On the SPM-19, set frequency, bandwidth, input, noise averaging in the usual way.

- Press " MEM " push button (LED on) and call-out

program No. 2012 = measurement; system 1 to system 2

program No. 2021 = measurements; system 2 to system 1

Call-out results through entry of program number and depressed "RCL" push button. Simultaneously the SPM-19 automatically measures digital level (LED lights above "DGTL" push button)

- Once again press "MEM" push button (LED is extinguished) and measure at the desired frequency

The function "Level Difference Measurement" is inhibited as soon as the push button in the DISPLAY field is actuated.

Through the push button sequence "MEM, 112, RCL" the prior entered program number for the measurement can be superimposed on the level display when the "RCL" push button remains depressed.

The level difference measurement may also be executed in computer automatic measuring systems.

4.25.3 PRINTER MODE

4.25.3.1 Demands placed on the printer

A printer is employed to great advantage particularly with long measurement sequences and comprehensive measuring programs, or with system surveillance.

With the aid of the V.24/V.28 Printer Interface BN 905/01 a printer with this interface can be connected to the Level Meter (see also 4.21). So a printer suitable for use with the SPM-19 must fulfill the following requirements:

- Interface V.24 (RS 232 C) with 25 terminal Cannon plug.
- 80 or more characters per line
- alphanumeric ASCII code, 8 bits including parity bit
- a RECEIVE ONLY version is sufficient, however, also a TRANSMIT and RECEIVE version is applicable.
- one of the following data transmission rates 150, 300, 600, 1200, 2400, 4800, 9600 bit/s.

- printing speed is appropriate to data transmission rate (about 1/10 of it).
- with even or odd parity

A printer that operates at 30 characters/s (or more) is recommended. For instance the Trend Communications Model 800 R0 8 in the Wandel & Goltermann Product Line.

Preparatory to laying out the printout format, the information in para. 6.4 should be taken into account because it furnishes information about adapting the interface, numbers of the lines and columns and also the writing time intervals.

4.25.3.2 Printout format

The printout format and the measuring sequence are specified through entry of a 4 digit program number $5X_2X_1X_0$ (Table 4-6).

This is shown in the examples illustrated in Fig. 4-20 to 4-22. A complete printout includes essentially:

- Measurement mode - title
- Measuring sequence (X_2)
- Measuring parameters for Receiver (X_0) and Generator (X_1)
- Column headings for the measured results (MHz, level unit, address)
- Measured results

Measurement modes employed for measuring the absolute values of level and phase jitter, the level difference (ABS-REF, the level referred to zero transmission level point dBm0) and the white noise quantities are adjustable on the front panel of the SPM-19. The measuring run (X_2) is setup by the entering of a program number as shown in Table 4-6. Both the individual results as well as the measuring sequence in one cycle with SINGLE AUTO STEP, TRACK, SINGLE SEARCH-SCAN; or in any cycle with CONT.AUTO STEP,CONT. SEARCH-SCAN can be entered on the keyboard.

The instrument parameters (X_0 and X_1) and also accordingly tolerance limits for the receive level are entered on the keyboard before the measurement and printout are executed. With the preselection of two level limits, the only measured results that are printed are those lying outside of the setup limits (see 4.25.3.5).

4.25.3.3 Printer release

The release of a single printout, after an automatic measuring sequence, results from the double function push button "LOCAL or PRINT" having been depressed.

During the printout program sequence the red LED is illuminated. The printout can be stopped through the push button being depressed once again. The repetition of the result printout with a single measurement or measuring sequence is possible by the entering of the PRINT function . Then the measurement mode title is again printed out after the program number or the push button sequence "MEM, 115, RCL, (MEM), PRINT" has been entered.

Program-No. = 5 X ₂ X ₁ X ₀				
MEASURING SEQUENCE	X ₂	Printout of instrument parameters	X ₁	X ₀
SINGLE MEASURING	0	* SPM-19 *		
CONT. MEAS.	1	NONE		0
		MODE + MEAS. RANGE (A)		1
AUTO STEP (SINGLE)	2	BANDWIDTH (B)		2
AUTO STEP (CONT.)	3	INPUT (C)		4
TRACK	4	A + B; A + C		3;5
		B + C; A + B + C		6;7
SINGLE SEARCH-SCAN	5	* PS-/PSS-19 *		
CONT. SEARCH-SCAN (OPT)	6	NONE	0	
		OUTPUT (A)	1	
		SEND LEVEL (B)	2	
		* Limit values SPM-19 * (C)	4	
		A + B; A + C	3;5	
		B + C; A + B + C	6;7	

Table 4-6 Program number structure

4.25.3.4 Operation

Three examples are used to explain how the SPM-19 is operated.

Example 1: Level difference measurement (e.g. frequency response) without tolerance limits, one-time measurement sequence
Measuring instruments: PS-19 (PSS-19) and SPM-19
Printout as in Fig. 4-20

- f_{START} , f_{STOP} , f_{STEP} settings on SPM-19 (PS-19 is externally controlled)
- set the instrument parameters according to the measuring task
- set reference frequency and store reference level (see 4.6.1.2)
- press push button "ABS-REF"
- press push button "MEM" and enter program number 5 $X_2 X_1 X_0$ according to Table 4-6
for example: 5237; where
 $X_2 = 2$, one-time measuring sequence (AUTOSTEP sets itself automatically)
 $X_1 = 3$, print all send data (A + B)
 $X_0 = 7$, print all receive data (A + B + C)
- MEM function switched out (LED off), otherwise stored frequencies would be set.
- press push button "LOCAL" (LED illuminates). SPM-19 begins at f_{START} . Repetition of results printout at end of measurement is possible through another press on push button "LOCAL" (LED illuminates again).

4.25.3.5 Setting the level threshold at the SPM-19

Two thresholds may be setup to cause a printout when only the stored upper or lower thresholds are exceeded. Figure 4-21 shows an appropriate printout with the measurement task of the first example repeated (Fig. 4-20). The two level thresholds are entered through the "dBr" push buttons and stored at addresses 109 and 110. Either sequence of entering is available.

LEVEL DIFFERENCE MEASUREMENT [ABS - REF]

REFERENCE LEVEL: - 28.50 DBM
 REFERENCE FREQ: 475.058 KHZ

MEAS. SEQUENCE: SINGLE AUTO STEP / 1 SEC. / FSTEP: 10.000 KHZ
 FSTART: 445.058 KHZ / FSTOP: 505.058 KHZ

REC. PARAMETERS

MODE: DGTL / AUTO CAL ON
 BANDWIDTH: 3.1 KHZ
 INPUT: BAL. / Z = 600 OHMS / R = HIGH IMP.

GEN. PARAMETERS

OUTPUT: BAL. / Z = 600 OHMS / R = 0
 OUTPUT LEVEL: 0.00 DBM

NO.	FREQUENCY KHZ	RESULT DB	NO.	FREQUENCY KHZ	RESULT DB
1	445.058	- 50.20	2	455.058	- 53.00
3	465.058	- 21.40	4	475.058	- 0.10
5	485.058	- 40.90	6	495.058	- 53.50
7	505.058	- 56.40			

Fig. 4-20 Printout: Level Difference Measurement
 (Program 5237)

LEVEL DIFFERENCE MEASUREMENT [ABS - REF]

REFERENCE LEVEL: - 28.50 DBM
 REFERENCE FREQ: 475.058 KHZ

MEAS. SEQUENCE: SINGLE AUTO STEP / 1 SEC. / FSTEP: 10.000 KHZ
 FSTART: 445.058 KHZ / FSTOP: 505.058 KHZ

REC. PARAMETERS

MODE: DGTL / AUTO CAL ON
 BANDWIDTH: 3.1 KHZ
 INPUT: BAL. / Z = 600 OHMS / R = HIGH IMP.

LIMITS: - 20.00 / - 55.00 DB

GEN. PARAMETERS

OUTPUT: BAL. / Z = 600 OHMS / R = 0
 OUTPUT LEVEL: 0.00 DBM

NO.	FREQUENCY KHZ	RESULT DB	NO.	FREQUENCY KHZ	RESULT DB
4	475.058	- 0.10	7	505.058	- 56.40

4-21 Printout: Level Difference Measurement with Tolerance Limits
 (Program 5277)

Entry:

- "dBr" push button pressed twice (two LED's illuminated)
- first level threshold entered via numerical keyboard and entry initiated by pressing the "+dBr" push button (MHz) or the -dBr pushbutton (kHz)
- press "MEM" push button (LED illuminated)
- push buttons "109 (or 110)" and "ST0" pressed
- second level threshold entered and stored under 110 or 109.

The program number is 5277 in this example; because $X_1 = 7$ all parameters A + B + C are taken into account.

4.25.3.6 Printout of white noise measurement results

The printout heading in addition contains the program number and also the relative level (TLP) in dBr.

The Level Meter is setup according to para 4.23.2. After the white noise program has been called out, e.g. "Measure the noise power" in pWOp (No. 1200) the printer program is called out direct.

e.g. the following push buttons are depressed in consecutive order:

"MEM, 1200, RCL, 5007 (single measurement), RCL, MEM, LOCAL (printer release)"

PAGE 1

```
NPR MEASUREMENT [ PROG. NO. 1025 ]
MEAS. SEQUENCE CONT AUTO STEP / 3 SEC
REC PARAMETERS
MODE                DGTL / AVRG ON / AUTO CAL ON
BANDWIDTH:          1.74 KHZ
INPUT:              COAX. / Z = 75 OHMS / R = 2
```

ADR. NO.	FREQUENCY KHZ	RESULT DB	ADR. NO.	FREQUENCY KHZ	RESULT DB
9	3886.000	60.20	10	5340.000	60.20
9	3886.000	59.90	10	5340.000	59.90
9	3886.000	59.90	10	5340.000	59.90
9	3886.000	60.20	10	5340.000	60.20
9	3886.000	60.20	10	5340.000	60.20

4-22 Printout: Intrinsic NPR of an SPM-19
(Program 5307)

4-91

Fig. 4-22 shows the intrinsic NPR values of an SPM-19 picked at random from a lot. It has two stored test frequencies. The Level Meter is loaded with white noise of 12 MHz bandwidth. Measurement is implemented as a continuous measurement ($X_2 = 1$).

4.25.3.7 Error annunciation in the printout

Instead of warning arrows (see para 4.6.3) the following symbols are printed in front of the result when a measurement is not valid:

H (HIGH) The true measured value is higher than the printed value¹⁾.

L (LOW) The true measured value is lower than the printed value¹⁾.

E (ERROR)²⁾ Operating, overload, or hardware fault

4.25.3.8 Dialog for modifying the printout

Printers with a keyboard (e.g. TREND 800 KSR 8) permit dialog mode of operation with the printer interface in the Level Meter. After push button "ESC" has been depressed the current printer format can be interrogated (see Fig. 4-23 and para 6.4.7). Thereupon, alterations can be individually made through dialog: line number 66/72, column number 1/2, printout automatic/manual³⁾, and paging.

Above this, an additional text, TITLE, with a max. of 30 characters can be printed, if the text has been written into the main memory of the interface. With that, however, with "PAGING?" the instruction "Y" (yes) must be entered. It is recommended that all entries be made in capital letters (Function "CAPS LOCK" is on).

1) In the ANALOG mode the meter pointer is outside of the scale range.

2) With the noise loading measurement (see 4.23.2.2) the "E" in the result signifies a power of 10 (e.g. 4.5 E - 2 = 4.5×10^{-2}).

3) The printer release is implemented via the "SPACE" key. The prior measured value is printed.

Longer texts may be written into the printout when the printer keyboard is enabled through the keys, "SHIFT" and "*", (switch to "LOCAL").

After the Level Meter has been switched off, the printer interface is reset to the format that had been selected on the DIP switches (see para 6.4).

```
MODIFY PRINT MODE:
KEY: 'Y' FOR YES, 'N' FOR NO, 'RETURN' FOR NO CHANGE, 'ESC' FOR ABORT
PRINT ACTUAL SETTINGS? >> Y <<
  PAGELENGTH 66  SET
  1 COLUMN      RESET
  PAGING       RESET
  RESULTS ARE PRINTED AUTOMATICALLY
  TITLE:
PAGELENGTH 66 ? >> N <<
1 COLUMN ? >> N <<
PRINT RESULTS AUTOMATICALLY? >> Y <<
PAGING? >> Y <<
INPUT TITLE? >> Y <<
  END TITLE WITH 'RETURN' ( 30 CHARACTERS MAX. )
  TO CORRECT KEY 'DEL'
  >> OBJECT 4711 20.5.81. VP2/KP <<
RESET PAGENUMBER? >> N <<
```

Fig. 4-23 Dialog between printer and interface

1	Introduction
2	Chapter 1: The Basics of Electronics
3	Chapter 2: Circuit Analysis
4	Chapter 3: Semiconductor Devices
5	Chapter 4: Amplifiers
6	Chapter 5: Digital Electronics
7	Chapter 6: Microprocessors
8	Chapter 7: Power Electronics
9	Chapter 8: Communication Systems
10	Chapter 9: Control Systems
11	Chapter 10: Electromagnetic Interference
12	Chapter 11: Safety in Electronics
13	Appendix A: Component Values
14	Appendix B: Conversion Tables
15	Appendix C: Symbols and Abbreviations
16	Index

5. MEASURING NOTES

5.1 SELECTIVITY CURVES OF THE LEVEL METER

Figures 5-1 and 5-2 show the overall selectivity of the level meter for the selectable bandwidths 3.1 kHz, 1.74 kHz, 400 Hz and 25 Hz. These figures show typical selectivity curves of a standard production instrument.

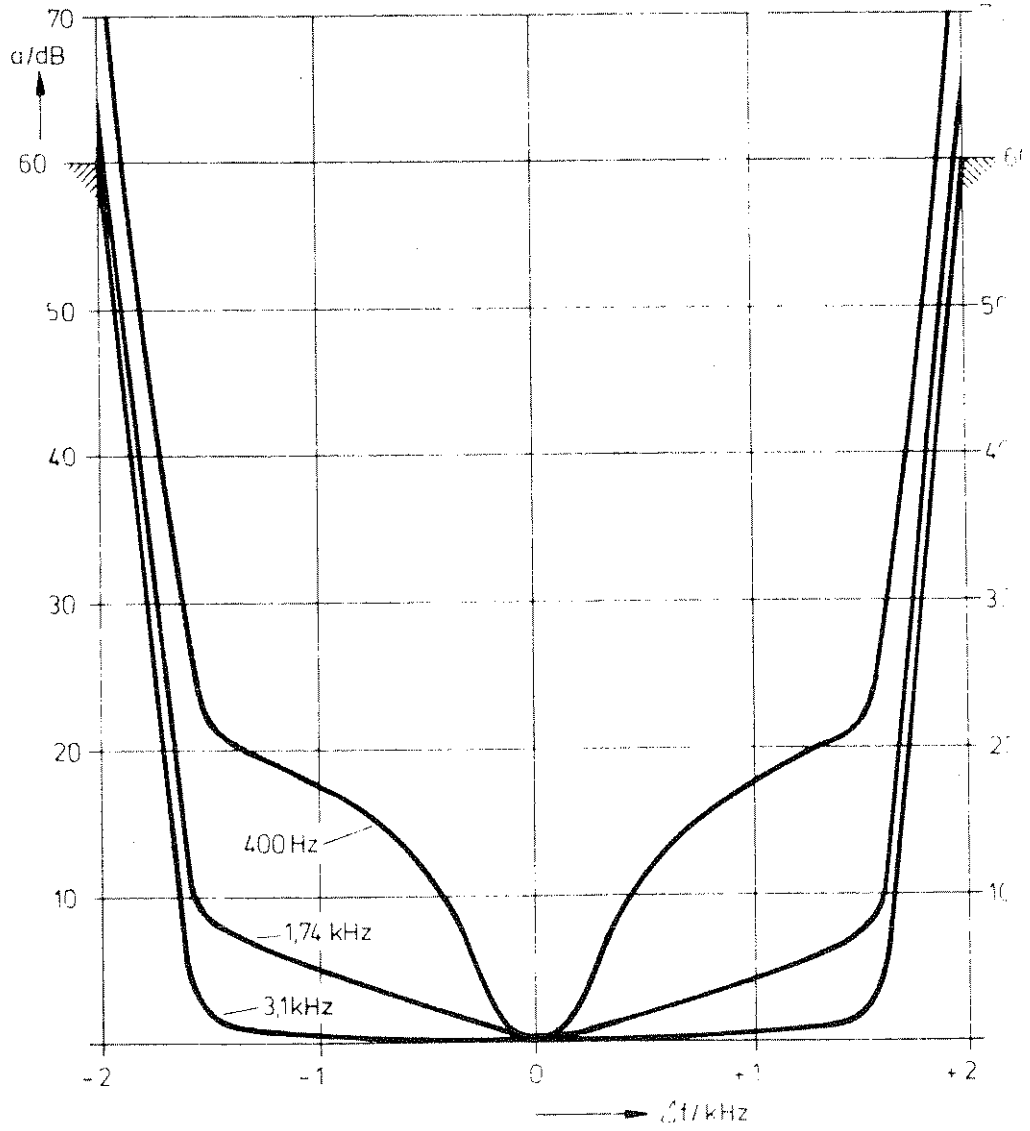

Figure 5-1 Typical selectivity curves for the bandwidths 400 Hz, 1.74 kHz, and 3.1 kHz.

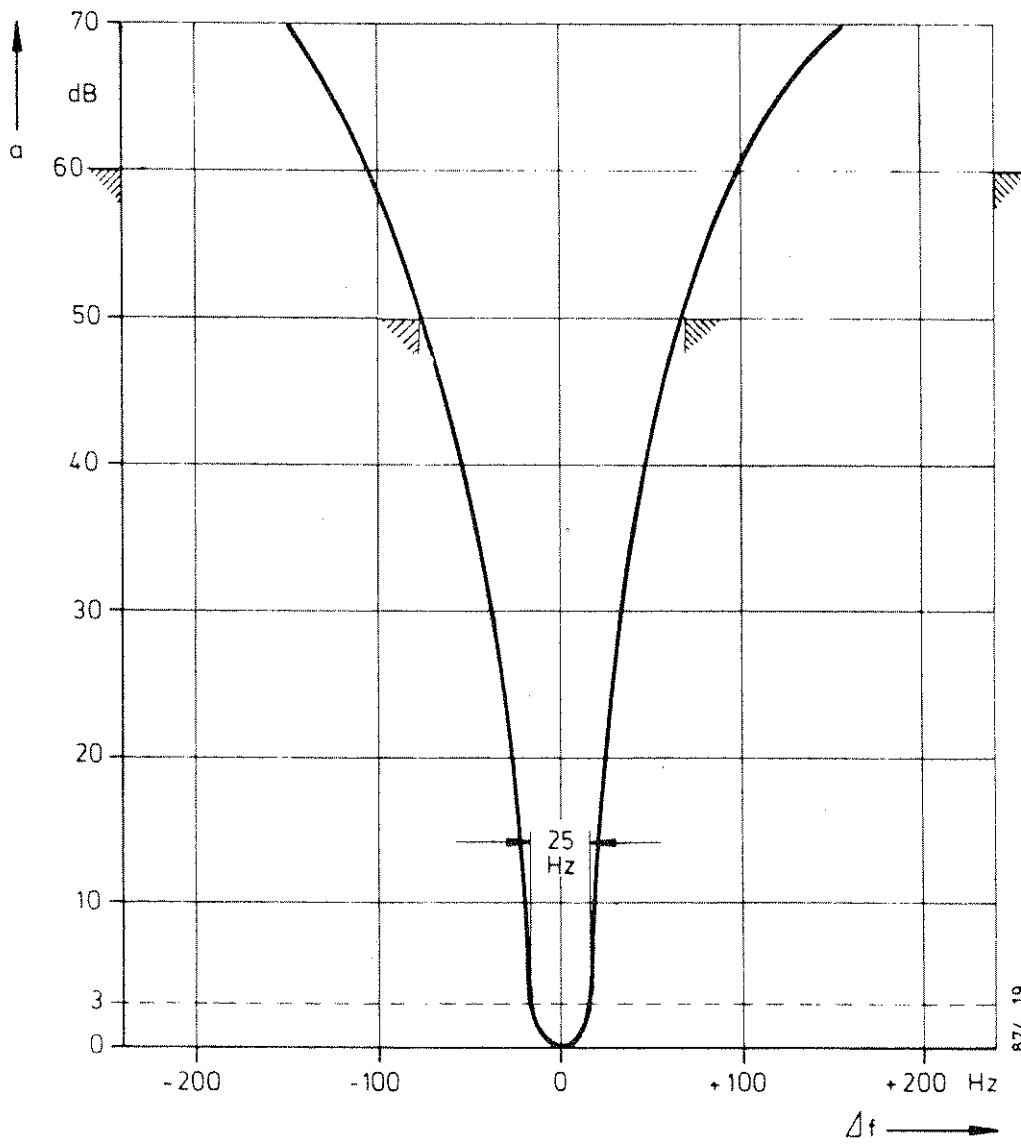

Figure 5-2 Typical selectivity curve of the level meter with bandwidth 25 Hz.

MEASUREMENT OF HIGH ATTENUATION VALUES

In the case of level measurements on four-pole networks with high attenuation values, a high return impedance Z_s between the generator and receiver of the measuring set-up is necessary (see Figure 5-3). If the return impedance is not infinitely large, the voltage drops across the ground line resistances r_1 and r_2 of the test cables used cause additional measuring errors. In order to keep these small, Z_s must be large with respect to r_1 and r_2 for practical applications. In the SPM-19, a high return impedance was achieved by decoupling the ground of the measuring circuit from the chassis ground (floating measuring input).

The effects of the above-mentioned resistances on the measurable attenuation are described in the following section.

The object to be tested is a four-pole network with an infinitely large attenuation. Z_s is the return impedance r_1 and r_2 are the unavoidable ground line resistances¹⁾, which can also be complex just like Z_s . The voltage drop resulting from the generator current through r_1 causes a voltage to exist between the chassis of the generator and the receiver.

1) r_1 and r_2 are often called "coupling impedances" in coaxial cables, plugs, etc., and are defined as follows:

Coupling impedance =

$$\frac{\text{Voltage drop on the outside of the outer conductor}}{\text{Current on the inside of the outer conductor}}$$

Coupling impedance =

$$\frac{\text{Voltage drop on the inside of the outer conductor}}{\text{Current on the outside of the outer conductor}}$$

If the return impedance Z_s is finite, a signal current flows through r_2 , causing a signal voltage at the receiver input and simulating a finite attenuation of the object being tested.

A simple calculation assuming that r_1 and r_2 are small with respect to R_i , R_e , Z and Z_s shows

$$\frac{U_2}{U_0} = \frac{r_1}{R_i + Z} \cdot \frac{r_2}{Z_s} \cdot \frac{R_e}{R_e + Z}$$

In the case where $R_i = R_e = Z$, the effective attenuation is

$$\begin{aligned} a &= 20 \text{ dB} \cdot \lg \frac{U_0}{2 \cdot U_2} \\ &= 20 \text{ dB} \cdot \lg \frac{2 \cdot Z \cdot Z_s}{r_1 \cdot r_2} \end{aligned}$$

For a maximum measuring error of 0.01 dB, for example, this attenuation must be approximately 60 dB (approximately 40 dB for 0.1 dB) greater than the attenuation to be measured if the worst case of the phase angle between the measured voltage and the error voltage is assumed.

The magnitude of the return impedance Z_s is approximately 40 Ohm over most of the whole frequency range.

If r_1 and r_2 are assumed to be at 10 mOhm each - this is the value of the coupling impedance of a good, double-screened coaxial cable with a length of 50 cm - then the affective attenuation with $Z = 75$ Ohm and $Z_s = 40$ Ohm for the configuration shown in Fig. 5-3 is 156 dB.

With a measurable attenuation of, for example, 96 dB with a test set-up PS-19/SPM-19, the value of 156 dB calculated under the above assumptions leads to a maximum additional error of 0.01 dB.

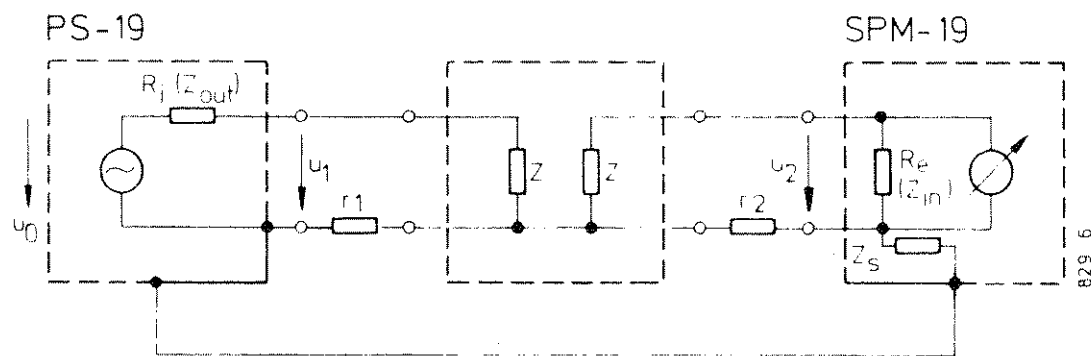

Figure 5-3

5.3

PULSE NOISE AND INTERRUPTION MEASUREMENTS

Measurement of the parameters phase jitter, pulse noise, and interruptions are becoming more and more important for assessing the transmission quality of telephone lines for data transmission. Pulse noise and interruptions cannot be measured directly with the SPM-19, but the unit can be used together with the demodulator for conversion of single speech channels or measured signals from the CF

frequencies to the AF range. In order to avoid measuring errors, particular attention was paid to ensuring that the modules which participate in conversion into the speech channel have, as closely as possible, the characteristics of CF channel converters. For this reason, the level meter also has the bandwidth of 3.1 kHz, which corresponds to that of a telephone channel. For faithful reproduction of the speech channel, the level meter must be tuned to the center of the CF channel. The demodulator output is characterised by a wide dynamic range, which is necessary for pulse noise measurement (see section 4).

The two transmission line parameters measured above can now be measured with external devices (e.g. DLM-3). For interruption measurements, the converted 2 kHz signal can be extracted at the demodulator output if the SPM-19 is tuned to the carrier frequency measuring tone. Due to the excellent level and frequency stability of the level meter, measurements can also be carried out over longer periods.

5.4

PSOPHOMETRIC WEIGHTING OF NOISE VOLTAGES

It is a well-known fact that the sensitivity of the human ear is frequency dependent. For simulation of this characteristic for measuring purposes, the so-called psophometric filter is used to simulate this frequency response including the transmission characteristics of the handset (Figure 5-4). This permits correct weighting of the noise existing in telephone channels.

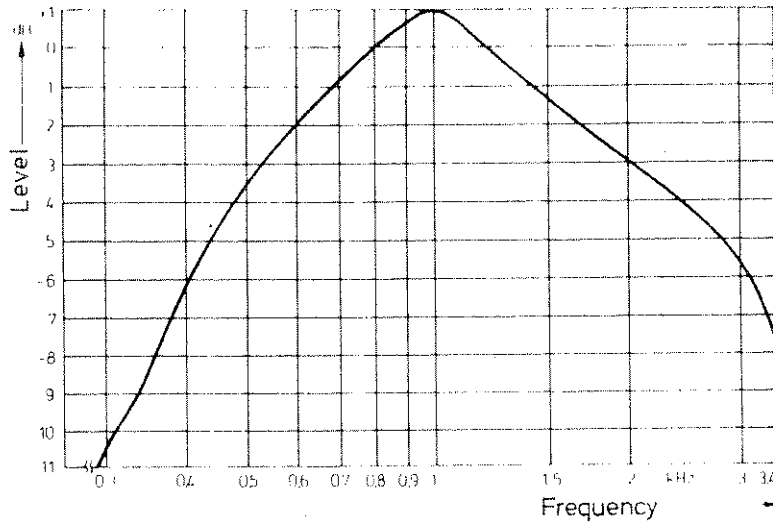

Figure 5-4 Psophometric curve

If, however, the noise within a telephone channel is "white", which can be assumed in the case of CF transmission, the psophometric filter can also be replaced by a flat band-pass filter which has the same effective bandwidth (see Figure 5-5). The level meter is equipped with the bandwidth of 1.74 kHz for this purpose.

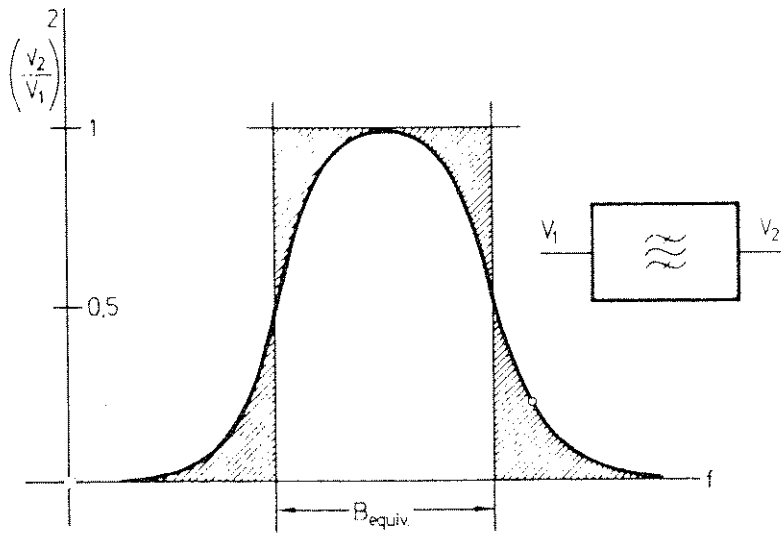

Figure 5-5 Selectivity curve and effective noise bandwidth.

829 8

The SPM-19 uses a genuine rms value meter which is calibrated such that the indication for the effective value of a sinusoidal voltage and for white noise is practically equal.

The drive levels for the complete signal path, including the rectifier circuit, are selected such that precise noise measurements are possible (crest factor 12 dB).

5.5 AUTOMATIC DRIVE LEVEL MONITORING

In order to increase the measuring accuracy, some modern level meters have facilities for selection by the operator of low noise or low distortion modes. With the aid of this control, the gain in the wide-band input stage preceding the first mixer and in the intermediate frequency section after the last conversion can be varied in a specific ratio, while maintaining the same overall gain. However, this solution is a compromise and can cause confusion and errors if the signals are unknown. The level meter SPM-19 with its built-in microcomputer offers an optimum solution to this problem, as it automatically selects the most favorable equipment drive levels as a function of the wide-band load present at the test input. To do this, the wide-band gain is increased step-by-step and the microprocessor checks the IF level for non-linear components. As soon as these are detected, the wide-band gain is reduced by one step ensuring that there is again a linear relationship between the input and output levels. This principle ensures that incorrect settings are not possible and always guarantees the maximum possible measuring accuracy.

6.

FUNCTIONAL TESTING, MAINTENANCE, AND MISCELLANEOUS

The following information is provided to permit correct function of the level meter SPM-19 to be checked. This permits the user to determine whether the unit has any major faults (such as could result from transport damage). A test of all functions is carried out as described in section 6.1 when the unit is switched on for the first time. A functional test of the most important modules (internal hardware test) can be carried out as described in section 6.2.

6.1

FUNCTIONAL TEST WHEN SWITCHING ON FOR THE FIRST TIME

The functional test is carried out when the level meter is switched on for the first time. The cable connections shown in Figures 3-3 and 6-1 must be provided for this test. The test is carried out in the sequence specified in Table 6-1, Pages 6-2 and following.

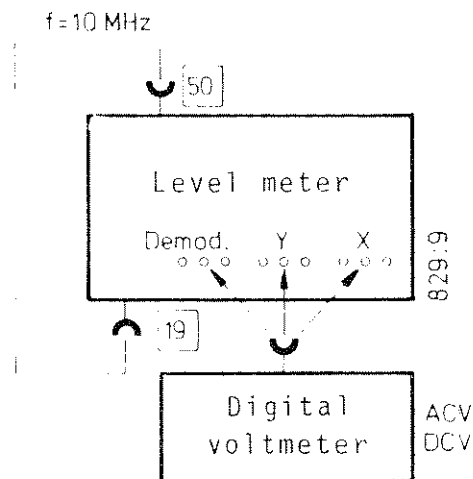

Figure 6-1 Test configuration for the functional test





<u>A C T I O N</u> Pushbutton or setting	<u>R E A C T I O N</u> Level or frequency display, LED
MEM, 9001, kHz	Unit set to standard set-up: $f = 100.000$ kHz, ABS, ANLG, 20 dB scale, bandwidth 3.1 kHz (the standard set-up is also transferred to the memories for front panel settings, addresses 100-110).
$f = 10234$ kHz $f = 6.78$ MHz CLR f_{STEP} $f_{START} = 8$ MHz $f_{STOP} = 12$ MHz f_{CENT} Δf	Frequency display: 10.234.000 kHz 6.780.000 kHz 0 1.000 kHz 8.000.000 kHz 12.000.000 kHz 10.000.000 kHz 4.000.000 kHz
MAN Turn knob 14 MAN Turn knob 14	LED "FINE" lights Frequency change in 1 Hz steps LED "COARSE" lights Frequency changes in 100 Hz steps
$f = 10$ kHz ↑ STEP ↓ STEP	Frequency display: 10.000 kHz 11.000 kHz 10.000 kHz
STEP	LED "TRACK" lights
STEP	LED "AUTO" lights. Frequency steps by 1 kHz per second.
SWEEP  SWEEP 	Frequency sweeps from 8 MHz to 12 MHz or vice versa. Unit sweeps between 8 MHz and 12 MHz
f_{STOP} ↓ Search f_{START} ↑ SEARCH	Frequency search towards lower frequencies and stops at 10 MHz Frequency search towards higher frequencies and stops at 10 MHz
Switch 17 to OPT SWEEP 	Frequency search between 8 and 12 MHz and stops at 10 MHz. Restart by depressing the pushbutton SWEEP 

Table 6-1 Sequence of functional test

A C T I O N	R E A C T I O N
Select all positions with switch 17	Corresponding LED lights
f = 9.9985 MHz AFC AFC	Frequency display: 9 998.500 kHz 10 000.000 kHz Signal detector lights LED alongside AFC is switched off.
Depress pushbuttons ABS and REF simultaneously (ABS-REF)	Level display: approx. -12 dB/-2 dBm Level display: 0 dB, meter: 0 dB
80 dB scale	Level display: 0 dB, meter: 0 dB LED on 80 dB scale of meter lights
20 dB scale	LED on 20 dB scale of meter lights.
AUTO CAL AUTO CAL	Red LED above pushbutton AUTO CAL lights Red LED above pushbutton AUTO CAL is switched off
1 dB scale	LED on 1 dB scale of meter lights Meter indication: 0 dB
Select bandwidth 1.74 kHz, 400 Hz, 25 Hz und WIDE	Corresponding LED lights Meter indication: 0 dB
Position 	Indication: 0 dB 2 kHz tone audible (if necessary, adjust volume 20)
ABS Φ P-P	Indication < 0.3°
Bandwidth 3.1 kHz Depress pushbuttons ABS and REF simultaneously (ABS-REF) Select measuring range 20 dB with switch 9	Indication 0 dB Meter indication: -20 dB
AUTO SET	Meter indication: -5 dB Measured level: (5-5) dB = 0 dB

Table 6-1 Sequence of functional test (continued)

<u>A C T I O N</u>	<u>R E A C T I O N</u>
DGTL	Level indication: 0.0 dB
AVRG	Level indication: 0.00 dB (<u>+</u> 0.02 dB)
REF	Level indication: approx. -12 dB/-2 dBm (ref. level)
dBr	Level indication: +0.0 dBr (relative level)
dBr	LED alongside KEYBOARD ENTRY lights
Enter the previously displayed reference level (REF) as a relative level via 12	The level indication is entered with a resolution of 0.1 dB.
Terminate the input with pushbutton -dBr or +dBr (+/- according to reference level)	Entered level is displayed in dBr LED alongside KEYBOARD ENTRY is switched off.
dBm0	Level indication: 0.00 dBm0/dB <u>±</u> 0.1 dB (reduced level)
Connect digital voltmeter (ACV) to demodulator output 23	
Switch demodulator  on.	AC voltage at output: approx. 1.5 V
Connect digital voltmeter (DCV) to Y-output 24	
Depress ABS and REF simultaneously (ABS-REF), ANLG Adjust range switch 9 for 0 dB indication on meter	DC voltage at Y-output: 4 V <u>±</u> 50 mV
Connect digital voltmeter (DCV) to X-output 25	
f _{START}	DC voltage at X-output: -2.5 V <u>±</u> 50 mV
f _{STOP}	DC voltage at X-output: +2.5 V <u>±</u> 50 mV

Table 6-1 Sequence of functional test (continued)

Further tests are carried out as described in section 6.1.1 to 6.1.3.

6.1.1

CHECKING THE INTERNAL NOISE

Settings on the SPM-19:

- Select coaxial input and input impedance $R_E = 75 \text{ Ohm}$ with **15** .
No test signal should be connected to the input sockets.
- Select digital mode with pushbutton **DGTL** and display of the absolute level with pushbutton **ABS** .
- Select bandwidth 3.1 kHz with changeover switch **16** .
- Tune the level meter to 2 MHz with keyboard **12** (see section 4.4.1).

Typical measured values:

for bandwidth 3.1 kHz	Noise level -127 dB (-118 dBm)
for bandwidth 1.74 kHz	Noise level -130 dB (-121 dBm)
for bandwidth 400 Hz	Noise level -135 dB (-126 dBm)
for bandwidth 25 Hz	Noise level -140 dB (-130 dBm)



6.1.2

CHECKING THE RECEIVER SELECTIVITY

Settings on the SPM-19:

As in section 6.1, but





- Enter frequency $f = 10 \text{ MHz}$ via keyboard **12** (see section 4.4.1).
- Connect the 10 MHz standard frequency (socket **50** on rear of unit) to test input **19** .
- Depress pushbutton **ABS** and **REF** simultaneously.
- Depress pushbutton **ABS-REF** ; indication is 0.0 dB.
- Depress pushbutton **f_{STEP}** and enter 2 kHz on keyboard **12** (see section 4.4.1).
- Depress pushbutton **f** ; indication is 10 MHz.

- Change the tuned frequency up or down by one step (≈ 2 kHz) with STEP pushbutton  or  and read the level display.

Attenuation compared with the reference value ≥ 60 dB. These values are also true for the 1.74 kHz and 400 Hz bandwidths. For the 25 Hz bandwidth, the attenuation must be ≥ 60 dB at an offset $f_{STEP} = \pm 250$ Hz from the center of the band (10 MHz).

6.1.3 FUNCTIONAL TEST OF THE TEST PROBE CONNECTOR

This test is carried out without a test signal at the inputs.

- Select digital mode with pushbutton  and absolute level display with pushbutton .
- Note the displayed absolute level.
- Connect the power supply cable of the test probe TK-11 to socket  and read the indicated level. The digital display is corrected by +10 dB. The same result can be achieved if ground potential is connected to socket .

6.2 FUNCTIONAL TESTS OF IMPORTANT MODULES (INTERNAL HARDWARE TEST)

A functional test of the most important modules (internal hardware test) can be executed by recalling program number 9003. No external connections are required for this purpose as the internal calibration signal is used as a signal source.

Sequence:

Depress the following pushbuttons:

9003

If the test is successful, the message 1----- appears on the frequency display. The level meter can then be switched back from the test program to the measuring program by depressing pushbutton . In the case of a fault, an error number (e.g. 1--003) appears in the frequency display; these error numbers are explained in Table 6-2. Repairs should be carried out only by trained personnel. If it is not possible to repair the faulty module, which means that the unit has to be sent into the factory for repair, it is recommended that you also specify the error number which occurred.

An RAM/ROM test is carried out automatically by the level meter when power is switched on (see section 3.5). The meanings of the error numbers for this test are also shown in Table 6-2.

CLASS	0	FAULT IN CONTROL SECTION (NOT VIA IEC BUS)
	0-----	NO FAULT, INDICATION OF TEST EXECUTION
	0--1-L	RAM FAULT ON D0...D3 THE ADDRESS IS SHOWN IN THE LEVEL DISPLAY
	0--1H-	RAM FAULT IN D4...D7 THE ADDRESS IS SHOWN IN THE LEVEL DISPLAY
	0--1HL	RAM FAULT ON D0...D3 AND ON D4...D7 THE ADDRESS IS SHOWN IN THE LEVEL DISPLAY THE ADDRESS IS DISPLAYED IN HEX WITH THE FOLLOWING CODES: L FOR A H FOR B P FOR C A FOR D - FOR E (BLANK) FOR F
	0--200	ROM FAULT
	0--300	THE BATTERY VOLTAGE WAS TOO LOW WHEN THE INSTRUMENT WAS SWITCHED ON. THE STANDARD SETUP IS SET. ALL FIXED FREQUENCIES AND INSTRUMENT SETUPS ARE ERASED IN THE RAM

Table 6-2 Summary of error numbers in the SPM-19

CLASS I: HARDWARE TEST

INDICATION: 9003 INTERNAL TEST RUNNING

INDICATION: 1-----INTERNAL TEST IS COMPLETE AND NO
FAULT WAS DETECTED IN THE LEVEL
MEASURING SECTION.

TEST GROUP 00X

FUNCTIONS: GENERAL MODULE TEST

THE TEST SIGNAL IS THE CALIBRATION LEVEL AT
F = 10 kHz.

THE SIGNAL PATH IS THE WIDE-BAND MEASURING PATH.
(PREAMPLIFIER II IN WIDE-BAND SECTION AND 10 dB
SWITCHING IN IF SECTION ARE ON).

ERROR MESSAGES:

1--001 LEVEL AT WIDE-BAND DETECTOR IS TOO LOW

POSSIBLE FAULTS:

CARRIER FREQUENCY NOT CONNECTED.
FAILURE OF ONE OR MORE MODULES BETWEEN CALIBRA-
TION MIXER AND WIDE-BAND DETECTOR.

1--002 LEVEL AT WIDE-BAND DETECTOR TOO HIGH

POSSIBLE FAULTS:

FAILURE OF ONE OR MORE MODULES BETWEEN CALIBRA-
TION MIXER AND WIDE-BAND DETECTOR.

Table 6-2 Summary of error numbers in the SPM-19 (continued)

1--003	LEVEL AT SIGNAL DETECTOR TOO LOW. POSSIBLE FAULTS: FAILURE OF ONE OR MORE MODULES BETWEEN WIDE-BAND DETECTOR AND SIGNAL DETECTOR
1--004	LEVEL AT ANALOG-DIGITAL CONVERTER (ADC) TOO LOW.
1--005	LEVEL AT ANALOG-DIGITAL CONVERTER (ADC) TOO HIGH POSSIBLE FAULTS: FAILURE OF ONE OR MORE MODULES BETWEEN SIGNAL DETECTOR AND ADC
1--006	LEVEL ABOVE SELECTIVE BRANCH IS TOO LOW
1--007	LEVEL ABOVE SELECTIVE BRANCH IS TOO HIGH POSSIBLE FAULTS: FAILURE OF ONE OR MORE MODULES IN THE MIXER SECTION
1--008	CALIBRATION SWITCH WILL NOT STAY AT THE MEASURING INPUT PREREQUISITE FOR THE VALIDITY OF THE FAULT: A POSSIBLE INPUT LEVEL MUST NOT EXCEED -60 dB AT 25 MHz.

Table 6-2 Summary of error numbers in the SPM-19(continued)

TEST GROUP 01X:

FUNCTION: TEST OF THE GAIN CHANGEOVER SWITCH IN WIDE-BAND
SECTION AND IN IF SECTION
TEST SIGNAL AS ABOVE
SIGNAL PATH IS THE SELECTIVE PATH

ERROR MESSAGES:

- 1--010 PREAMPLIFIER I AND PREAMPLIFIER II
 IN BB SECTION MUST NOT BE INTERCHANGED
- 1--011 0 dB CHANGEOVER SWITCH IN IF SECTION DOES NOT REACT
- 1--012 20 dB CHANGEOVER SWITCH IN IF SECTION DOES NOT REACT
- 1--013 INPUT ATTENUATOR I IN BB SECTION DOES NOT REACT
- 1--014 FIRST 30 dB CHANGEOVER SWITCH IN IF SECTION DOES
 NOT REACT
- 1--015 INPUT ATTENUATOR II IN BB SECTION DOES NOT REACT
- 1--016 SECOND 30 dB CHANGEOVER SWITCH IN IF SECTION DOES
 NOT REACT

TEST GROUP 02X:

FUNCTION: TEST FOR INVALID FREQUENCY RESPONSE DEVIATIONS
SIGNAL PATH IS THE SELECTIVE PATH
WIDE-BAND GAIN: -30 dB
IF GAIN: +50 dB

ERROR MESSAGES:

- 1--020 INVALID FREQUENCY RESPONSE DEVIATION AT 2 kHz
- 1--021 INVALID FREQUENCY RESPONSE DEVIATION AT 10 kHz
- 1--022 INVALID FREQUENCY RESPONSE DEVIATION AT 100 kHz
- 1--023 INVALID FREQUENCY RESPONSE DEVIATION AT 1 MHz
- 1--024 INVALID FREQUENCY RESPONSE DEVIATION AT 10 MHz
- 1--025 INVALID FREQUENCY RESPONSE DEVIATION AT 25 MHz

Table 6-2 Summary of error numbers in the SPM-19 (continued)

SYNTHESIZER FAULTS

1--101 ERRONEOUS RESULT OF ADDITION IN ADDER CIRCUIT
1--102 ADDER COUNT IS NOT FINISHED
1--103 ADDER SIGNAL DAC REMAINS LOW

CALIBRATION ADJUSTING NETWORK

1--201 INSUFFICIENT EXTENT WITH ANALOG
1--202 INSUFFICIENT EXTENT WITH DIGITAL

POSSIBLE ORIGINS OF FAULT

- * DEFECTIVE CALIBRATION ADJUSTING NETWORK IN IF amplifier
- * BASIC GAIN OF COMPLETE EQUIPMENT IS SET WRONG
- * DEFECTIVE CALIBRATION SIGNAL OR GAIN SETTING

CLASS 2: OPERATOR ERRORS

2--001 INVALID ADDRESS NUMBER
2--002 ROM ADDRESS: "STORE" NOT POSSIBLE
 (FIXED FREQUENCY OR SET-UP FROM EPROM)
2--003 ADDRESS CAN BE USED ONLY WITH "RECALL"
 (TO RECALL WHITE NOISE, PRINTER, AND TEST PROGRAMS)
2--004 START AND STOP ADDRESS ARE IN DIFFERENT RANGES
 (BOTH MUST LIE EITHER BETWEEN 0 AND 99 OR BETWEEN
 200 AND 299)
2--005 ADDRESS NOT PROGRAMMED
2--101 MEASURING RANGE TOO SENSITIVE
2--102 MEASURING RANGE TOO INSENSITIVE
2--103 WIDE-BAND SECTION OVERDRIVEN (WITH 80 dB SCALE)
2--104 MEASURING RANGE UNSUITABLE FOR "STORE ABS AS REF"

Table 6-2 Summary of error numbers in the SPM-19 (continued)

2--105	DYNAMIC MEASURING RANGE NOT REACHED (ONLY WITH IEC BUS AT RANGE SETTING AND DYNAMIC MARGIN +25/-75 dB)
2--106	DYNAMIC MEASURING RANGE EXCEEDED (ONLY WITH IEC BUS AT RANGE SETTING AND DYNAMIC MARGIN +25/-75 dB)
2--201	"STORE ABS AS REF" NOT PERMITTED (SWEEP OR SEARCH MODE)
2--301	48 kHz BANDWIDTH IS POSSIBLE ONLY WITH DIGITAL FREQUENCY SETTING OR AUTOSTOP
2--311	PHASE JITTER IS ONLY MEASUREABLE AS ABSOLUTE
2--312	PHASE JITTER IS ONLY MEASUREABLE WITH DIGITAL FREQUENCY SETTING OR "CONTINUOUS".
CLASS 3:	FAULTS IN THE DIGITAL INTERFACE 40 41
3--000	INITIALIZATION REQUEST FROM A PERIPHERAL DEVICE (TO BE REGARDED AS AN ACKNOWLEDGEMENT AND NOT AS A FAULT: APPEARS DURING INITIALIZATION OF THE DEVICE)
3--101	"TIME-OUT ON IBF (INPUT BUFFER FULL)" WITH GENERATOR (DATA WERE TRANSMITTED TO GENERATOR AND NOT READ WITHIN THE PRESET TIME)
3--102	"TIME-OUT ON OBF (OUTPUT BUFFER FULL)" WITH GENERATOR (DATA WERE REQUESTED FROM THE GENERATOR BUT NOT SUPPLIED WITHIN THE PRESET TIME)
3--103	GENERATOR WAS INITIALIZED AND HAS LOGICALLY DISCONNECTED ITSELF FROM THE RECEIVER. (THE GENERATOR WAS SWITCHED OFF OR HAS RECEIVED INVALID COMMANDS OR DATA).

IF THE ABOVE FAULTS OCCUR, THE DATA CONNECTION BETWEEN THE RECEIVER AND THE GENERATOR SHOULD BE CONNECTED.

Table 6-2 Summary of error numbers in the SPM-19(continued)

6.3 MAINTENANCE AND MISCELLANEOUS

The level meter SPM-19 requires no special maintenance provided it is handled correctly. The closed case protects the electronic circuits at all times, even during transport. The use of the corresponding protective cover SD 4 is recommended in order to protect the controls on the front panel and the sockets on the rear of the unit against splash water, dust, and mechanical damage. In addition, the SPM-19 can be carried with the carrying handle of the protective cover.

For major transport under rough conditions, the use of the equipment case TPK-4 or the transport case TPG-4 is recommended (see section 3.1.2).

6.3.1 MECHANICAL CONSTRUCTION

Caution: Before opening the unit, disconnect the mains plug from the outlet socket. The unit must always be switched off before removing or inserting modules or optional features.

The case dimensions comply with the DIN Standard 41 494 and the American Standard ASA C 83.9. The unit can therefore be mounted in 19" racks (see section 3.1.3). The cover, baseplate, and side walls are made of robust cast aluminum. For servicing purposes, it is possible to remove the six hexagon head cap screws (wrench on the rear of the unit), to take off the equipment cover, and to lift the complete chassis including the front panel and the rear wall from the case.

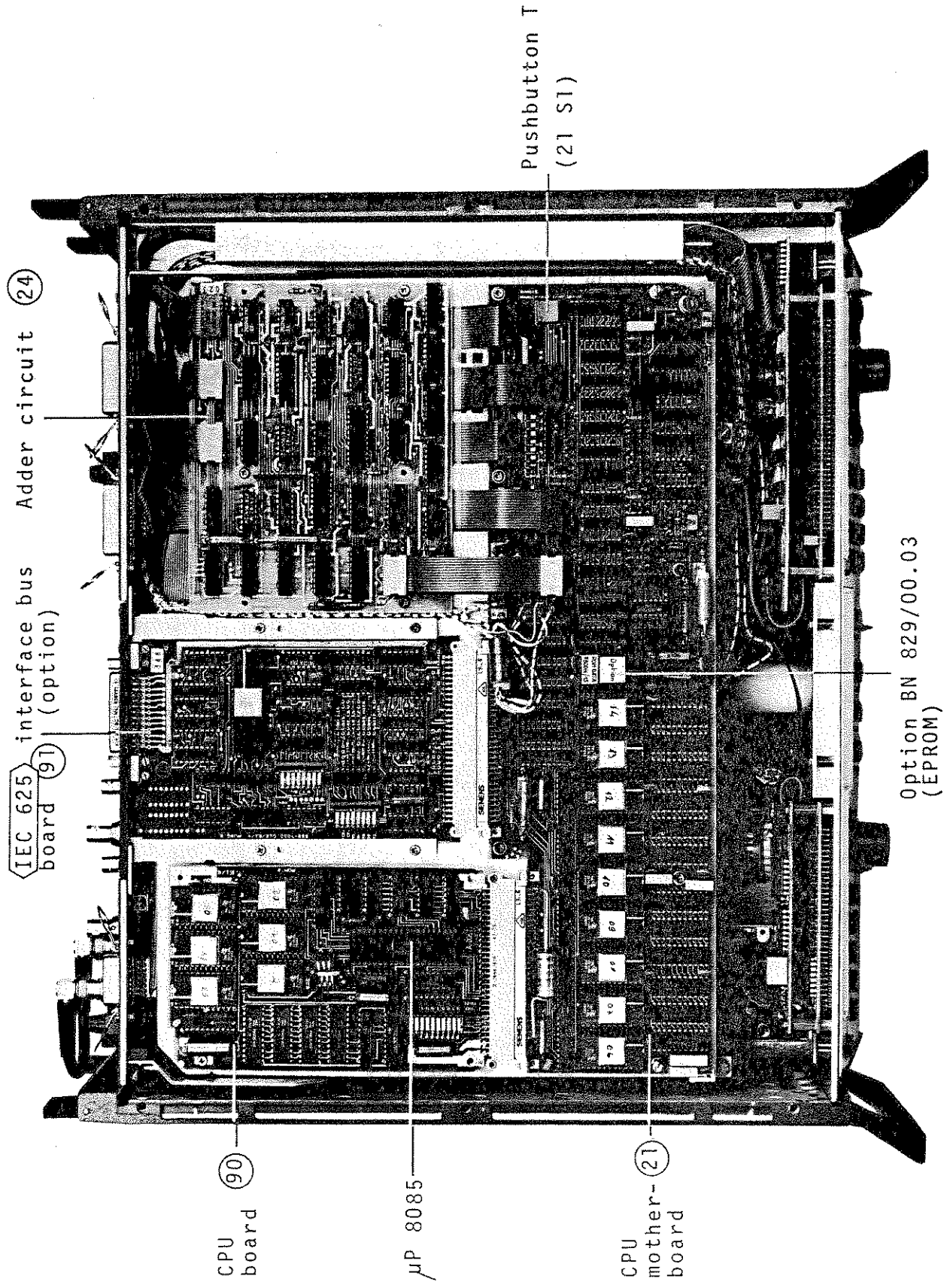

Figure 6-2 Upper side of the upper folding chassis

When doing this, remember that the chassis is connected to the power supply unit on the right wall of the case via a plug connector. All modules are accessible from the top and the bottom if the two screws of the two folding chassis are removed.

When assembling, ensure that the blue flat cable is not trapped between the chassis and the case. During repairs, ensure that the upper folding chassis cannot fall, as this could result in damage to the cables.

Figure 6-2 shows details of the components in the upper folding chassis after removal of the equipment cover and the chassis cover. Amongst other things, the microprocessor (INTEL 8085) and the free positions for the optional accessories IEC bus board or printer interface and PROM (white noise program, fixed frequencies, set-ups) with customer-specific programs can be seen in this figure. The pushbutton T is depressed only after repair in order to initialize the unit if the buffer battery for the RAM power supplies was disconnected during repair (see section 3.6).

6.3.2 CHANGING OR INSTALLING THE INTERFACE BOARDS

The plug-in modules printer interface BN 905/01 or IEC 625 interface bus board BN 853/02 are installed from the rear of the unit (see Figure 4-2). Removing the two outer screws provides access to the compartment and the board can be inserted or changed (component side on the top). The interface board is then held in position with the two screws.

6.3.3 INSTALLING THE PROM BN 829/00.02 or BN 829/00.03

The PROM can be installed in the unit at any time. As the data are stored in a MOS memory module (EPROM), the board must be installed as described below due to the sensitivity of the circuit to static charges.

Generally, whenever working with MOS components, all tools, working benches, equipments and users should have the same reference potential. For this reason, the MOS module should be installed as follows:

1. Switch off the level meter.
2. Remove the six hexagon head cap screws (wrench on the rear of the unit) and take off the equipment cover and the chassis cover.
3. Hold the unit (reference potential) with one hand, remove the MOS module from its packing material with the other hand (holding it at the ends), and insert it in the position shown in Figure 6-2. The module is oriented correctly if the inscription on the component is the same as on socket.
4. Fit the equipment cover and chassis cover, screw it down, and switch on the level meter.

6.3.4 UNIVERSAL CONNECTORS VERSACON[®] 9

The coaxial input, the inputs and outputs for control in standard frequencies, and the IF output at the level meter are equipped with the universal connector "Versacon[®] 9" made by Wandel & Goltermann (Figure 6-3). This has the advantage that it permits rapid conversion to one of the connection sockets shown below without soldering. The required socket adapter is screwed into the fixed universal socket, using the mounting wrench (Order No. W 1).



Figure 6-3 Basic socket Versacon[®] 9 with some of the available Versacon[®] 9 adapters

6.3.5 RECHARGEABLE BATTERIES FOR DATA RETENTION

The power supply unit on the right side wall contains rechargeable batteries: 3 Ni-Cd cells 501 RS, type "Mignon" IEC R 6. These ensure, if the mains voltage is interrupted temporarily or switched off, that the last settings which were entered and all stored data are retained. The batteries are trickle-charged whenever the level meter is switched on.

If the level meter was switched off for a longer period, it is recommended that it be left on for approximately 8 hours in order to fully recharge the batteries. The batteries are stored in the battery compartment N on the rear of the unit (see Figure 4-2). To replace the cells, remove the two philips head screws, permitting the battery holder to be pulled out.

When fitting new cells, ensure that their polarity is correct, as shown on the cover.

6.4 ADAPTATION OF THE V.24 - PRINTER INTERFACE

The Printer Interface BN 905/01 takes into account the CCITT Recommendation V.24 and V.28 or corresponding Standards (RS 232 C, DIN 66020). The switch array on the Interface Card permits the data output, Bu 1, to be adapted to various printers as needed. In addition the printout can be set to automatic or manual, or the printout format can be altered, and also a test of the interface can be executed. The three switches, whose position are shown in Figure 6-4, are accessible after the top cover has been removed from the instrument's case.

6.4.1 TEST OF INTERFACE, S 1/3

This test permits the determination of whether or not the waiting time has been correctly set or whether the printer's acknowledgement is functioning correctly.

The test results from switch S1/3 being closed momentarily.

Result: Three test lines with one empty line and succeeding V.24 Interface test (Test line: 012RST).

At the end of the test the RAM and ROM components have been shown to be either good or defective.

It is therefore particularly important to take notice that the characters at the beginning of every line are correct. Perhaps the waiting time must be altered.

6.4.2 AUTOMATIC PRINTOUT S 1/1

S 1/1 closed (normally closed): immediate printout of measured results.

S 1/1 open : manually released printout (6.4.3)

6.4.3 MANUAL PRINTOUT S 1/2

The fundamental switch setting is open. A short closure is sufficient to cause the prior measured value to be printed. The printout release can also be implemented through the "SPACE" key on the keyboard of a printer so equipped.

6.4.4 MODIFICATION OF THE PRINTOUT S 1/4, S 1/5

Line number

S 1/4 closed : 66 lines

S 1/4 open : 72 lines

Column number

S 1/5 closed : 1 column

S 1/5 open : 2 columns

6.4.5 PAGING S 1/8

S 1/8 closed : the printout follows automatically in pages with 66 or 72 lines

S 1/8 open : the printout is not divided into pages

6.4.6 WAITING TIME

For printers that can accept data faster than the speed of printing, the possibility of setting fixed waiting times at the ends of the lines or the possible presence of printer acknowledgements (BUSY on

contact 11 of the interface connector, Bu 1) might be used. See switches S 2/1 to 5 and S 2/8, S 2/9.

Switch closed	Waiting time
S 2/1	800 ms
S 2/2	400 ms
S 2/3	200 ms
S 2/4	100 ms
S 2/5	50 ms

Any combination can be selected to set a waiting time (max. 1550 ms)

6.4.7 PARITY ENABLE S 2/6 *

S 2/6 closed: a parity bit is attached to every character of the data being transmitted to the printer. This bit is ignored if the data source is the printer.

CAUTION: If the TREND Printer 800 KSR is employed, S 2/6 must be closed.

S 2/6 open: no parity bit, S 2/7 is not functional.

6.4.8 EVEN PARITY S 2/7 *

S 2/7 closed : the parity bit is even

S 2/7 open : the parity bit is odd

6.4.9 BUSY POLARITY S 2/8

When S 2/9 is closed, and if S 2/8 is closed:

BUSY line status is low; data transmission is halted when the voltage is <-3V on contact 11 of Bu 1.

S 2/8 open: BUSY line status is high

6.4.10 BUSY ENABLE S 2/9

S 2/9 closed: BUSY signal is effective on contact 11 of Bu 1. Data transmission is halted for a max. of 0.5 sec. If this interval is not sufficient, extra waiting time can be set-up.

*) Switch used only when SPM-19 is switched OFF

S 2/9 open : data transmission is not halted. S 2/8 must likewise be open !

6.4.11 FORM FEED ENABLE S 2/10

The function is effective when the Level Meter is switched ON and with PAGING.

S 2/10 closed: with printers that automatically set themselves to the beginning of the sheet, a new page is begun. In addition, four lines are left empty at the beginning of the sheet.

S 2/10 open : with endless paper printer the pages with empty lines are filled in so that with paging likewise the division of pages takes place.

6.4.12 BAUD RATE S 3/1 to /3 *)

Baud rates between 150 and 9600 bit/s are switch selectable. The switches must be arranged as follows:

Baud rate	S 3/1	S 3/2	S 3/3	
9600	1	1	1	
4800	1	1	0	0 ≙ switch open
2400	1	0	1	1 ≙ switch closed
1200	1	0	0	
600	0	1	1	
300	0	1	0	
100	0	0	1	

6.4.13 ADAPTATION TO THE BASIC UNIT S 3/5 to /8 *)

The positions of these switches are instrument specific and must not be altered!

The switches must be set in the following configuration:

S 3/5 : ON (1)

S 3/6 : OFF (0)

S 3/7 : ON (1)

S 3/8 : ON (1)

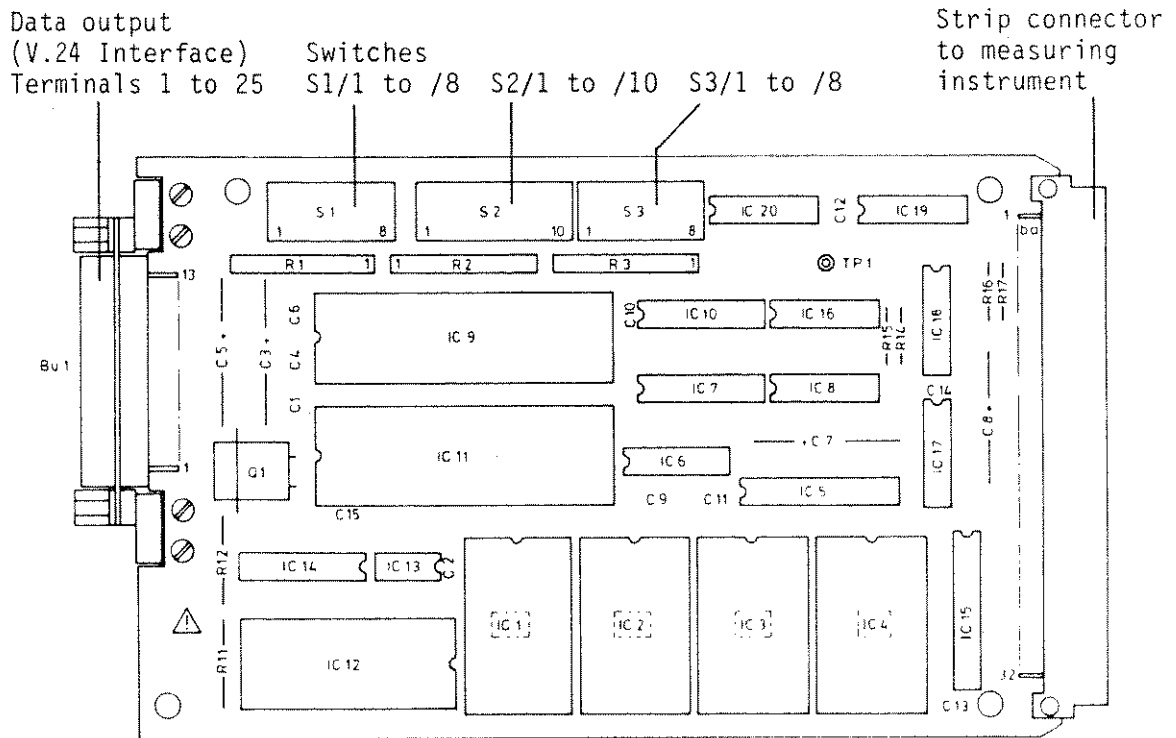

Figure 6-4 V.24 Printer Interface BN 905/01

