

**VALHALLA SCIENTIFIC, INC.**

---

**2300 SERIES**  
**DIGITAL POWER ANALYZERS**

---

**OPERATION MANUAL**

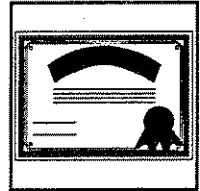


**9955 MESA RIM ROAD**  
**SAN DIEGO, CA 92121**  
**(619) 457-5576**  
**(619) 457-0127 Fax**

## CERTIFICATION

---

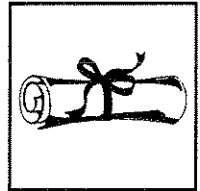
Valhalla Scientific, Inc. certifies that this instrument was thoroughly tested and inspected and found to meet published specifications when shipped from the factory. Valhalla Scientific, Inc. further certifies that its calibration measurements are traceable to the National Institute of Standards and Technology to the extent allowed by NIST's calibration facility.



## WARRANTY

---

The warranty period for this instrument is stated on your invoice and packing list. Please refer to these to determine appropriate warranty dates. We will repair or replace the instrument during the warranty period provided it is returned to Valhalla Scientific, Inc. freight prepaid. No other warranty is expressed or implied. We are not liable for consequential damages. Permission and a return authorization number must be obtained directly from the factory for warranty repairs. No liability will be accepted if returned without such permission. Due to continuing product refinement and due to possible parts manufacturer changes, Valhalla Scientific reserves the right to change any or all specifications without notice.

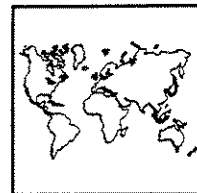


**This manual covers the following Valhalla Scientific products:**

**Models 2300, 2301, 2300L and 2301L**

## SECTION I UNPACKING & INSTALLATION

---



### 1-1. Introduction

The Valhalla 2300 Series of Power Analyzers provides true RMS (AC+DC) measurements of voltage up to 600 volts, current up to 100 amps and power up to 60 kilowatts per phase. The maximum voltage and current input limits may be extended through the use of current and/or potential transformers. Nearly every conceivable power measurement application is discussed in later sections of this manual.

In addition to the versatility of connections, the 2300 Series boasts an optional computer interface, available reduced voltage ranges for greater resolution, high accuracy and excellent frequency response. Recently added to the list of options available for the Model 2301 is the Valhalla Model 1000A High Current Measurement System which enables the user to directly measure up to 1000 amps of current with many times the accuracy of a clamp-on type current transformer. Please refer to Section 3-2.

**Read this manual thoroughly before attempting to use the power analyzer!** Dangerous voltages are routinely present in and connected to this instrument. This instrument may be damaged by improper connections to the rear input terminals. Double check connections before applying power.

For convenience, in future descriptions the 2300 Series of Power Analyzers will be referred to as a "2300" unless specific differences between models exist. In this case the reader will be informed of any necessary changes.

### 1-2. Inspection

If the shipping carton is damaged, request that the carrier's agent be present when the unit is unpacked. If the instrument appears damaged, the carrier's agent should authorize repairs before the unit is returned to the factory. Even if the instrument appears undamaged, it may have suffered internal damage in transit that may not be evident until the unit is operated or tested to verify conformance with its specifications. If the unit fails to operate or fails the tests of Section 2-7, notify the carrier's agent and the nearest Valhalla Sales Office. Retain the shipping carton for the carrier's inspection. **DO NOT** return equipment to Valhalla Scientific or any of its sales offices prior to obtaining authorization to do so.

### 1-3. Initial Adjustments

The only adjustments required prior to operation of the 2300 are to set the rear panel selector switch to the local AC line voltage and to verify that the correct fuse for this voltage is fitted. The supply voltages and their corresponding fuses are listed below:

105 to 125 VAC, 50 to 400Hz    1 Amp Slo Blo

210 to 250 VAC, 50 to 400Hz    0.5 Amp Slo Blo

**ENSURE THAT THE CORRECT LINE VOLTAGE SELECTION IS MADE PRIOR TO APPLYING POWER TO THE 2300!**

### 1-4. Bench Use

The 2300 is delivered for operation in bench use and special instructions for use

in this manner other than the procedures of Sections 4, 5 and 6 are not required.

### **1-5. Rack Mounting**

Optional brackets are available for mounting the 2300 in a standard 19" equipment rack. These are listed in Section 3 of this manual. The size and weight of the 2300 require that the unit should be supported on both sides along its entire length by the use of "trays" or "slides". If it is to be transported while mounted in a rack then **it must be supported so as to prevent upward and downward movement.**

The user should note that the specifications for the 2300 become degraded at high temperatures thus it is required that sufficient room be allowed for airflow around the 2300. This may be achieved by placing a minimum 1.75" blank panel above and below the 2300 in the rack.

If a unit placed beneath the 2300 has an unusually hot exterior top surface and it is not possible to alter its location, it is recommended that an aluminum "reflector" plate be used between this unit and the 2300.

Under no circumstances should the ambient air temperature surrounding the 2300 be allowed to exceed 50°C while in operation or 70°C while in storage.

### **1-6. Safety Precautions**

The power connector is a three-contact device and should be mated only with a three-contact connector where the third contact provides a continuous ground connection. A mating power cord has been provided. If the power is provided through an extension cable then the ground connection must be continuous throughout this cable.

**Failure to provide a continuous ground connection to the 2300 may render the unit unsafe for use!**



## SECTION II SPECIFICATIONS

---



### 2-1. Voltage Specifications

The accuracy figures given below are valid for ambient temperatures between 20°C and 30°C for a period of one year from the date of calibration following a 1 hour warm-up period.

#### 2-1-1. Voltage Ranges and Resolutions

Models 2300L and 2301L Ranges:	5V	15V	30V	60V
Resolution:	1mV	1mV	10mV	10mV
Models 2300 and 2301 Ranges:	50V	150V	300V	600V
Resolution:	10mV	10mV	100mV	100mV

#### 2-1-2. Voltage Accuracy and Bandwidth

For all models @ 20°C to 30°C for 1 year. True RMS, DC coupled (AC+DC)

DC and 20Hz to 5KHz:	± 0.1% of reading ± 6 digits
5 KHz to 15KHz:	± 0.5% of reading ± 6 digits
15KHz to 20KHz:	± 0.75% of reading ± 6 digits

Useable above 20KHz to 50KHz with typically an additional 1% error per 10 KHz.

#### 2-1-3. Miscellaneous Voltage Specifications

Temperature Coefficient: ± 1/10 of accuracy specification per °C (0-19°C and 31-50°C)

Crest Factor: 50:1 at minimum input linearly decreasing to 2.5:1 at full scale

Minimum Input: 5% of range

Maximum Input: ± 1500V peak

Peak Indicator: Illuminates at 2 times range

Input Impedance: 2300L and 2301L = 100K $\Omega$  (All Ranges)  
2300 and 2301 = 1M $\Omega$  (All Ranges)

## 2-2. Current Specifications

The accuracy figures given below are valid for ambient temperatures between 20°C and 30°C for a period of one year from the date of calibration following a 1 hour warm-up period.

### 2-2-1. Current Ranges, Resolution and Bandwidth

	<u>Low Shunt</u>	<u>Medium Shunt</u>	<u>High Shunt</u>
Ranges:	0.2A, 0.5A, 1A	2A, 5A, 10A	20A, 50A, 100A
Resolution:	100 $\mu$ A	1mA	10mA
Impedance:	100m $\Omega$	10m $\Omega$	1m $\Omega$
Bandwidth:	DC & 20Hz-10kHz	DC & 20Hz-5kHz	DC & 20Hz-1kHz
Max Input:	2A continuous	20A continuous	150A continuous
Peak Input: (no damage)	100msec @5A (fused)	100msec @50A	100msec @500A

### 2-2-2. Current Accuracy

For all models @ 20°C to 30°C for 1 year. True RMS, DC coupled (AC+DC)

$\pm 0.5\%$  of reading  $\pm 0.5\%$  of range at DC  
 $\pm 0.25\%$  of reading  $\pm 0.25\%$  of range from 20Hz to bandwidth

### 2-2-3. Miscellaneous Current Specifications

Temperature Coefficient:  $\pm 1/10$  of accuracy specification per °C (0-19°C and 31-50°C)

Crest Factor: 50:1 at minimum input linearly decreasing to 2.5:1 at full scale

Minimum Input: 5% of range

Peak Indicator: Illuminates at 2 times range

Shunt Compliance Voltage: 100mV at full scale on highest range for shunt (1A, 10A, 100A)



**2-3. Power Specifications**

The accuracy figures given below are valid for ambient temperatures between 20°C and 30°C for a period of one year from the date of calibration following a 1 hour warm-up period.

**2-3-1. 2300L/2301L Single-Phase Resolution (Watts)**

<u>Range</u>	<u>0.2A</u>	<u>0.5A</u>	<u>1A</u>	<u>2A</u>	<u>5A</u>	<u>10A</u>	<u>20A</u>	<u>50A</u>	<u>100A</u>
5V	1.0000	2.500	5.000	10.000	25.00	50.00	100.00	250.0	500.0
15V	3.000	7.500	15.00	30.00	75.00	150.00	300.0	750.0	1500.0
30V	6.000	15.000	30.00	60.00	150.00	300.0	600.0	1500.0	3000
60V	12.000	30.00	60.00	120.00	300.0	600.0	1200.0	3000	6000

**2-3-2. 2300/2301 Single-Phase Resolution (Watts)**

<u>Range</u>	<u>0.2A</u>	<u>0.5A</u>	<u>1A</u>	<u>2A</u>	<u>5A</u>	<u>10A</u>	<u>20A</u>	<u>50A</u>	<u>100A</u>
50V	10.000	25.00	50.00	100.00	250.0	500.0	1000.0	2500	5000
150V	30.00	75.00	150.00	300.0	750.0	1500.0	3000	7500	15000
300V	60.00	150.00	300.0	600.0	1500.0	3000	6000	15000	30.00KW
600V	120.00	300.0	600.0	1200.0	3000	6000	12000	30.00KW	60.00KW

**2-3-3. 2300L Three-phase Three-wire Resolution (Watts)**

<u>Range</u>	<u>0.2A</u>	<u>0.5A</u>	<u>1A</u>	<u>2A</u>	<u>5A</u>	<u>10A</u>	<u>20A</u>	<u>50A</u>	<u>100A</u>
5V	2.000	5.000	10.000	20.00	50.00	100.00	200.0	500.0	1000.0
15V	6.000	15.000	30.00	60.00	150.00	300.0	600.0	1500.0	3000
30V	12.000	30.00	60.00	120.00	300.0	600.0	1200.0	3000	6000
60V	24.00	60.00	120.00	240.0	600.0	1200.0	2400	6000	12000

**2-3-4. 2300 Three-phase Three-wire Resolution (Watts)**

<u>Range</u>	<u>0.2A</u>	<u>0.5A</u>	<u>1A</u>	<u>2A</u>	<u>5A</u>	<u>10A</u>	<u>20A</u>	<u>50A</u>	<u>100A</u>
50V	20.00	50.00	100.0	200.0	500.0	1000.0	2000	5000	10000
150V	60.00	150.00	300.0	600.0	1500.0	3000	6000	1500	30.00KW
300V	120.00	300.0	600.0	1200.0	3000	6000	12000	30.00KW	60.00KW
600V	240.0	600.0	1200.0	2400	6000	12000	24.00KW	60.00KW	120.00KW

**2-3-5. 2300L Three-phase Four-wire Resolution (Watts)**

<u>Range</u>	<u>0.2A</u>	<u>0.5A</u>	<u>1A</u>	<u>2A</u>	<u>5A</u>	<u>10A</u>	<u>20A</u>	<u>50A</u>	<u>100A</u>
5V	3.000	7.500	15.000	30.00	75.00	150.00	300.0	750.0	1500.0
15V	9.000	22.50	45.00	90.00	225.0	450.0	900.0	2250	4500
30V	18.000	45.00	90.00	180.00	450.0	900.0	1800.0	4500	9000
60V	36.00	90.00	180.00	360.0	900.0	1800.0	3600	9000	18000





### 2-3-6. 2300 Three-phase Four-wire Resolution (Watts)

<u>Range</u>	<u>0.2A</u>	<u>0.5A</u>	<u>1A</u>	<u>2A</u>	<u>5A</u>	<u>10A</u>	<u>20A</u>	<u>50A</u>	<u>100A</u>
50V	30.00	75.00	150.00	300.0	750.0	1500.0	3000	7500	15000
150V	90.00	225.0	450.0	900.0	2250	4500	9000	22.50KW	45.00KW
300V	180.00	450.0	900.0	1800.0	4500	9000	18000	45.00KW	90.00KW
600V	360.0	900.0	1800.0	3600	9000	18000	36.00KW	90.00KW	180.00KW

### 2-3-7. Power Accuracy and Bandwidth

For all models @ 20°C to 30°C for 1 year. True RMS, DC coupled (AC+DC)

±0.5% of watts reading ±0.5% of (volts range x amps range) at DC

±0.25% of watts reading ±0.25% of (volts rng x amps rng) throughout "Shunt Bandwidth"

#### Shunt Bandwidths

Low Shunt: 20Hz to 10KHz

Medium Shunt: 20Hz to 5KHz

High Shunt: 20Hz to 1KHz

Temperature Coefficient: ±1/10 of range specification per °C (0-19°C and 31-50°C)

### 2-4. Physical Specifications

Height 7" (178mm) not including feet  
Width 17" (432mm)  
Depth 19.75" (490mm)  
Weight 33lbs (15kg) net; 38lbs (17.5kg) shipping

### 2-5. Environmental Specifications

Temperature Range: Operating: 0°C to 50°C  
Storage: -20°C to +75°C

Humidity: 70% RH max @ 40°C (non-condensing)

Altitude: -10,000 to +10,000 feet

Vibration: Per MIL-T-28800C, Type III, Class 5, Style E

### 2-6. Miscellaneous Specifications

Settling Time: (to within 0.1% of change)

No range change: 1.5 sec  
Following range change: 5 sec



Maximum Common Mode Voltage: 1500V peak from any terminal to chassis

Power Factor Response: Zero to unity power factor, leading or lagging

Warm-up Time: 1 hour to specifications

Power: 50 to 400Hz @ 105-125VAC or 210-250VAC, 40VA max

Safety: Complies with UL1244 and IEC-348

Connections: Three sets of fully floating terminals, one for each channel

Input Configuration: Three-wire type wattmeter with three current inputs for each phase

Displays: Three simultaneous displays. One each for volts, amps, and watts.

Display Type: Red LED 4½ digits per display

Peak Overload Indication: Six LED's; one for voltage, one for current for each channel

Range Selection: Manual push-button or via Option TL-4 IEEE-488 interface

IEEE Interface (Option "TL-4"): Compliance with IEEE-488 (1978) with subsets SH1, AH1, T6, TE0, L4, LE0, SR1, RL1, PP0, DC1, DT1, C0

## **2-7. Performance Verification**

Verification of the performance of the Model 2300 may be performed at any time, and is especially recommended following receipt of the unit or following transportation. Verification may be achieved with two levels: verified as operational; verified as operational and within specifications. The procedures for both are given below.

### **2-7-1. Verification of Operation**

If the 2300 fails any of the tests below, employ normal troubleshooting procedures or consult the factory for advice.

- 1) Ensure that the POWER switch (lower left hand corner of the front panel) of the 2300 is in the OFF position, i.e. no yellow dot showing.
- 2) Ensure that the rear panel switch is set to the correct local line voltage and apply AC power to the 2300. Make no connections to the shunt input terminals under the flip lid.
- 3) Press the 2300 POWER switch to the ON position (yellow dot showing). The LED's on the front panel should illuminate in the 600V, 100A and  $\phi$ A positions, and the displays should indicate near zero. Wandering displays or continuous illumination of any overload indicator signifies that a problem may exist.
- 4) Allow the 2300 to warm up for 5 minutes.



- 5) Connect the 2300 as described in Section 6-4-1 to a known resistive load, e.g. a 100-watt incandescent light bulb. Verify that the voltage display reads the present line voltage, the current display reads approximately 1 amp, and the power display reads approximately 100 watts. This should be repeated for each of the 3 channels:  $\phi A$ ,  $\phi B$  and  $\phi C$ . Note that Model 2301 has only one channel.

After successful completion of all of the steps above, the 2300 is fully operational with no faulty parts apparent.

### **2-7-2. Verification of Specification**

Attempting to prove that the 2300 is performing to specification requires that the user be aware of the following points:

- 1) The specifications in Section 2 are valid for reasonable use of the 2300 during the specified period of time. If the 2300 has been transported it may have been subjected to extremes of temperature. As with any precision equipment some change in calibration may occur due to this. This effect has been carefully monitored by Valhalla Scientific and has been found to be small, even in extreme cases.
- 2) A wattmeter calibration system is required to verify the specifications of the 2300. A source of voltage and current in phase with each other is required to check the power accuracy. Phase shifts between voltage and current will cause measurement errors. The calibration procedure of Section 8 may be used as a guide for verifying specifications.
- 3) Prior to specification verification it is recommended that the user be familiar with the manual operation of the 2300 and allow at least one hour for the unit to warm up.

If the 2300 is found to be fully operational but not performing to specifications it is recommended that a full calibration be performed. If this does not bring all points within specifications, contact your nearest Valhalla Scientific Service Center before returning the unit for repair or attempting to repair the unit yourself.



## SECTION III AVAILABLE OPTIONS



### 3-1. General

The following options are available for the 2300 Series Digital Power Analyzers.

### 3-2. Extended Current Range

The standard 100 amp current measurement capability of the 2300 Series of Power Analyzers may be extended through the use of Options I-150, I-1000 and Valhalla Model 1000A.

#### 3-2-1. Options I-150 and I-1000

These options are 150 amp and 1000 amp clamp-on type current transformers. Both have 1000:1 ratios with 2% accuracies from 50Hz to 400Hz. Option I-150 accommodates up to 0.5" diameter conductors. Option I-1000 accommodates up to 2" diameter conductors.

#### 3-2-2. Valhalla Model 1000A

The newest addition to the list of options for the Model 2301 Power Analyzer is the Valhalla Model 1000A Precision High Current Measurement System. This unique instrument has the ability to directly measure up to 1000 amps (AC + DC) at a basic accuracy of  $\pm 0.02\%$  for DC. The modular design of the 1000A allows expandable current capacity in increments of 300 amps, 500 amps, 700 amps and 1000 amps. The 1000A may be matched to a Model 2301 to provide watts measurement capability. Please contact your local Valhalla representative or the factory for more details.

### 3-3. Options IO-1 and IO-3

Options IO-1 and IO-3 provide chassis ground referenced analog outputs for

watts only (IO-1) or for watts, volts and amps (IO-3). The outputs correspond to the data displayed on the 2301 (or 2300) front panel. If installed in a 2300, the outputs represent the displayed measurements for  $\phi A$ ,  $\phi B$ , or  $\phi C$ .

#### 3-3-1. Scaling

The scale factors of the analog outputs are listed below:

Full Scale Voltage and Accuracy (1 year, 1 hr warmup)

##### Option IO-1

Watts: 2.5V  $\pm 1.0\% \pm 15mV$

##### Option IO-3 (2301 or 2301L)

Watts: 5.0V  $\pm 0.5\%$  of output  $\pm 10mV$

Volts: 5.0V  $\pm 0.5\%$  of output  $\pm 10mV$

Amps: 5.0V  $\pm 0.5\%$  of output  $\pm 10mV$

##### Option IO-3 (2300 or 2300L)

Watts: 2.5V  $\pm 1.0\%$  of output  $\pm 10mV$

Volts: 5.0V  $\pm 0.5\%$  of output  $\pm 10mV$

Amps: 5.0V  $\pm 0.5\%$  of output  $\pm 10mV$

#### 3-3-2. Calibration

Refer to section 8-7 for the Option IO-3 calibration procedure. The analog output of Option IO-1 has no adjustment.

#### 3-3-3. IO-1 Connections

Watts analog data is available through a female BNC type connector (Figure 3-1). A mating cable, Option "CK", is available from Valhalla Scientific, Inc.

#### 3-3-4. IO-3 Connections

Watts, volts and amps analog data is available through a female 6 pin DIN connector. A mating plug is supplied with Option IO-3. Additional plugs are available from Valhalla Scientific under

stock number 05-10514. Connector pin assignments are shown in Figure 3-2.

### 3-3-5. Drive Capability

The output impedance of Option IO-3 is  $56\Omega$ . A maximum of  $\pm 100\mu\text{A}$  may be drawn from each output without exceeding specified accuracies.

### 3-4. Option IOX

Option IOX provides eleven simultaneous chassis ground referenced analog outputs corresponding to  $\phi\text{A}$  volts, amps, watts;  $\phi\text{B}$  volts, amps, watts;  $\phi\text{C}$  volts, amps, watts;  $3\phi$  3-wire total watts and  $3\phi$  4-wire total watts.

#### 3-4-1. Scaling and Accuracy

The scale factors and accuracies of the analog outputs are listed below:

Full Scale Voltage and Accuracy (1 year, 1 hour warm-up)

Watts	5V	$\pm 0.5\%$ of output $\pm 15\text{mV}$
Volts	5V	$\pm 0.5\%$ of output $\pm 15\text{mV}$
Amps	5V	$\pm 0.5\%$ of output $\pm 15\text{mV}$

#### 3-4-2. Calibration

Refer to Section 8-6 of this manual for the Option IOX calibration procedure.

#### 3-4-3. Connections

Connections to the analog outputs are made via a rear panel mounted connector. A mating connector is supplied with the Option IOX. Additional connectors are available from Valhalla Scientific under part number 05-10248. Connector pin assignments are shown in Figure 3-3.

#### 3-4-4. Drive Capability

The output impedance of Option IOX is  $56\Omega$ . A maximum of  $\pm 5\text{mA}$  may be drawn from each output without exceeding the accuracy specifications.

### 3-5. Option LF

This option provides extended low frequency performance (to 2Hz) at the expense of extended settling time. Settling time is increased by approximately 10 to 1.

**Note:** When Option LF is used in conjunction with Option TL-4, the kilowatt hour measurement should be multiplied x2.

### 3-6. Option RX7

Option RX7 is a set of rack ears that allow mounting of the 2300 in a standard 19" equipment rack.

### 3-7. Option TL-4

Option TL-4 provides the 2300 with a full talk/listen IEEE-488 digital interface. This interface may be used for remote range programming and for remote data acquisition. See Section 7 for details.

### 3-8. Options GP-1 and GP-2

These options are IEEE-488 cables for 1 meter and 2 meter lengths respectively. These cables may be used to connect to the interface of Option TL-4.

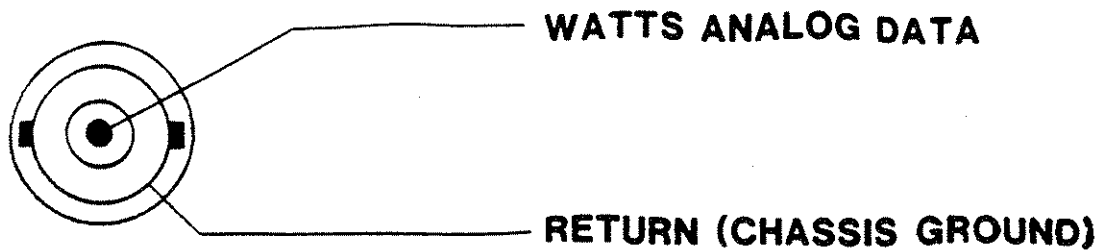
### 3-9. Options HS-5 and HS-12

These options increase the speed at which the 2300 communicates over the IEEE-488 bus (Section 7). A standard unit can be read at the rate of 2.5 times per second. Option HS-5 = 5 rdgs/sec and Option HS-12 = 12.5 rdgs/sec.

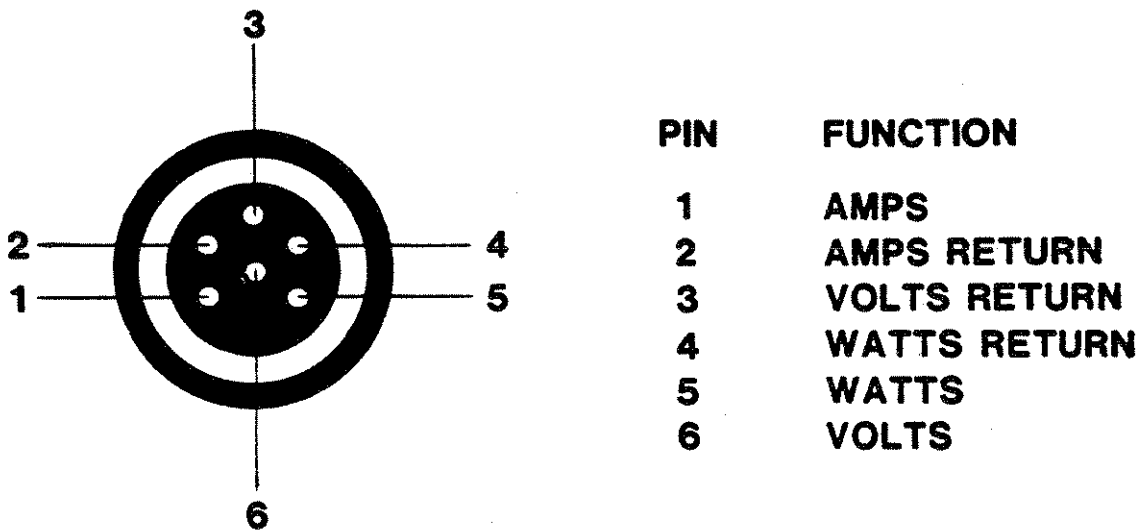
### 3-10. Option L

This option provides greater resolution when working with low voltages by reducing all standard voltage ranges by a factor of 10. Current ranges are unaffected. The voltage ranges become: 5V, 15V, 30V, and 60V.



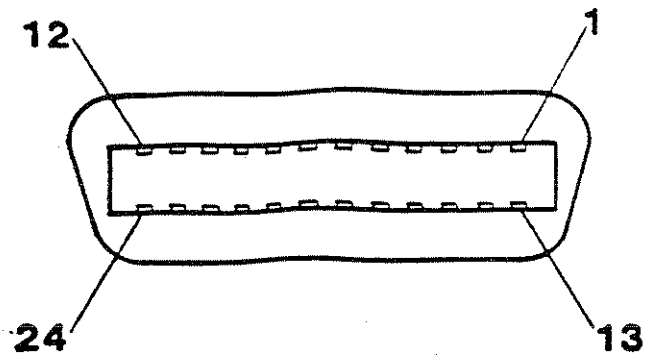


**FIGURE 3-1 OPTION IO-1 CONNECTIONS**



**FIGURE 3-2 OPTION IO-3 CONNECTIONS**





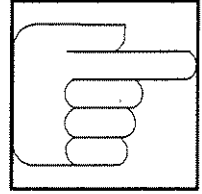
PIN	FUNCTION
1	ØA VOLTS
2	ØA AMPS
3	ØA WATTS
4	ØB VOLTS
5	ØB AMPS
6	ØB WATTS
7	ØC VOLTS
8	ØC AMPS
9	ØC WATTS
10	3Ø 3 WIRE TOTAL WATTS
11	3Ø 4 WIRE TOTAL WATTS
12-24	COMMON

**FIGURE 3-3 OPTION IO-X CONNECTIONS**



## SECTION IV FRONT PANEL CONTROLS

---



### 4-1. General

This section outlines the use of each of the front panel controls and connectors. The user is advised to read Section 6 to obtain full descriptions of the methods of operation of the 2300.

The paragraph numbers used in this section correspond to the reference numbers of Figure 4-1.

#### 4-1-1. "DISPLAY SELECTION" Section

This bank of push-buttons selects which phase's data is displayed in the volts, amps, and watts display windows. These buttons are used to switch between the V-A-W data for each individual phase. The total power in a three-phase load can be displayed by pressing the 3 $\phi$  3-wire or 3 $\phi$  4-wire push-buttons. These push-buttons are not installed in the 2301/2301L single-phase instruments.

#### 4-1-2. "WATTS - TRUE POWER" Window

The true power is displayed in this window as selected by the display selection push-buttons. The units of measure are either watts or kilowatts as indicated by the two LED indicators.

#### 4-1-3. "OVERLOAD" Display Window

A peak overload on any of the three voltage or three current channels is indicated by the LED's in this window. If an overload is indicated, the next highest voltage or current range should be selected. These indicators may also alert the user to the presence of large spikes on the input signal if the RMS value is not out of range, but an LED is still illuminated.

#### 4-1-4. "AMPS-TRUE RMS" Window

The true RMS current is displayed in this window as selected by the current range push-buttons.

#### 4-1-5. "IEEE-488" Window

When option TL-4 is fitted and remote operation is selected the "REMOTE" LED in this window will be illuminated.

#### 4-1-6. "VOLTS - TRUE RMS" Window

The true RMS voltage is displayed in this window as selected by the voltage range push-buttons.

#### 4-1-7. "VOLTAGE RANGE" Section

This bank of push-buttons selects the voltage range of the 2300. Voltage inputs greater than the selected range may yield invalid readings. The voltage ranges of the Model 2300L are 5, 15, 30, and 60 volts, respectively.

#### 4-1-8. "POWER" Switch

This switch controls the power to the 2300. When the "ON" position (depressed with the yellow dot showing) is selected and AC power supplied, the 2300 will be operational. When in the "OFF" (not depressed) position the 2300 will be unpowered.

#### 4-1-9. "CURRENT RANGE" Section

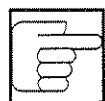
This bank of push-buttons selects the current range of the 2300. Current inputs higher than the selected range limit may yield invalid readings.



#### 4-1-10. RUN/HOLD Push-buttons

The RUN/HOLD feature on the Model 2300 may be used to simultaneously freeze the Volts, Amps and Watts displays. This is accomplished by pressing the button labeled "RUN/HOLD". A red LED indicates that the unit is in HOLD mode. A green LED indicates that the unit is in the RUN mode. While in the HOLD mode, the button labeled SAMPLE becomes active. This may be pressed briefly to update the displays without leaving the HOLD mode.

**Note:** Placing the instrument in the HOLD mode does not affect the overload indicators. It is possible to change ranges while in the HOLD mode however the displays will not be updated until either the SAMPLE button or the RUN/HOLD button is pressed. When using the IEEE-488 option, readings will be held in the buffer until updated by SAMPLE or RUN.



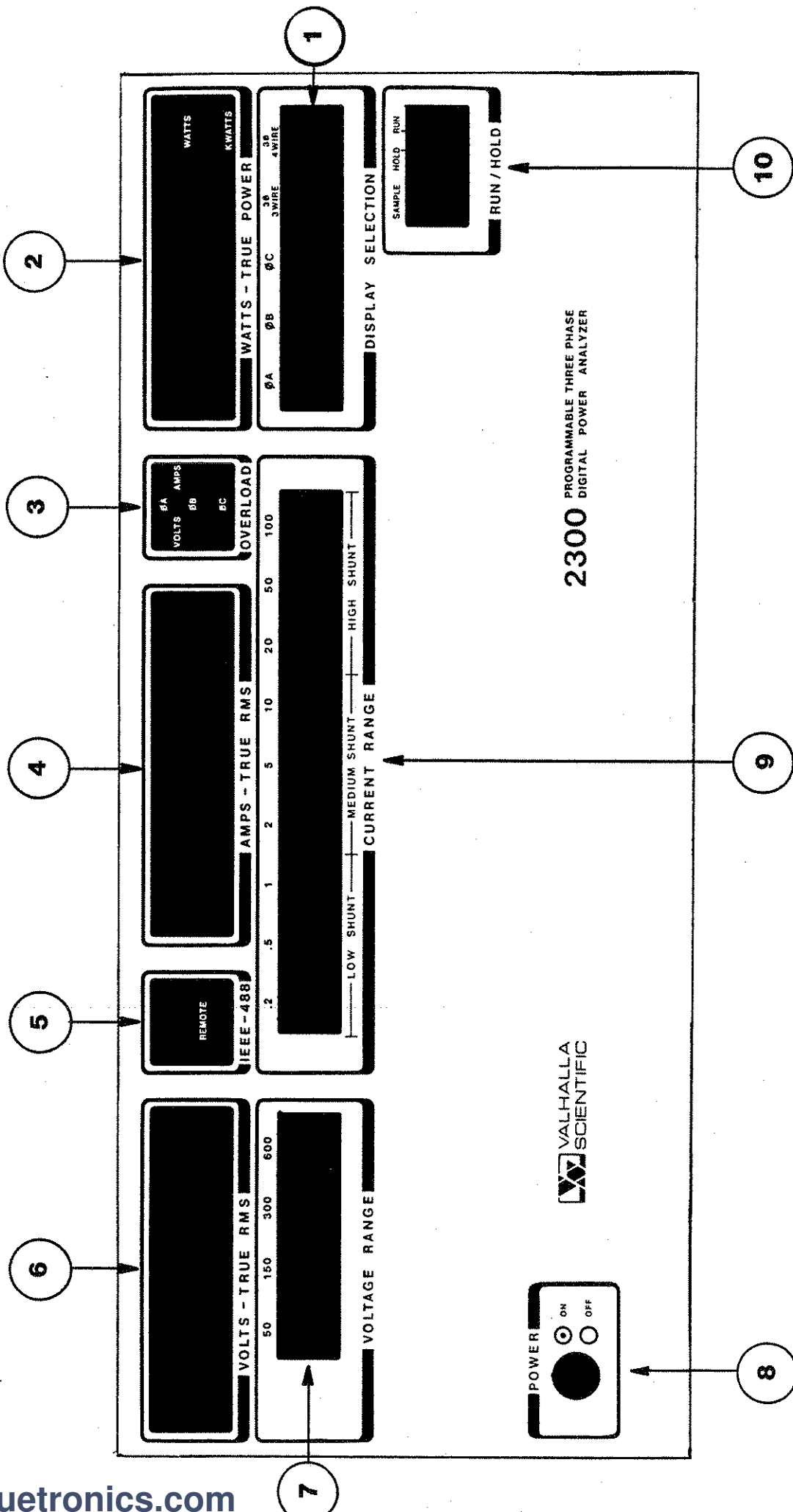
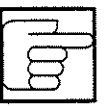
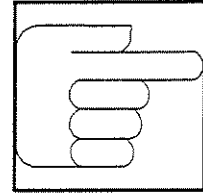


Figure 4-1. 2300 Front Panel



## SECTION V REAR PANEL CONTROLS

---



### 5-1. General

This section outlines the functions of the rear panel controls and connectors. The user is advised to also refer to Sections 4 and 6 for complete operating instructions. The paragraph numbers used in this section correspond to the reference numbers of Figures 5-1 and 5-2.

#### 5-1-1. "POWER" Connector

This is the instrument AC power connector. Use the appropriate 3-prong cord *only*.

#### 5-1-2. "FUSEHOLDER"

This contains the main AC power fuse. Fuse values are listed on the 2300 rear panel.

#### 5-1-3. "LINE VOLTAGE" Switch

This switch selects the instrument AC power voltage between 115VAC or 230VAC.

#### 5-1-4. "IO-3" Connector

This is the Option IO-3 analog output connector (if installed).

#### 5-1-5. "IOX OR IEEE" Connector

This is the Option IOX analog output connector or the Option TL-4 IEEE interface connector (if installed).

#### 5-1-6. "IEEE ADDRESS" Switch

This is the Option TL-4 IEEE interface address switch. This is blank if Option IOX is installed.

#### 5-1-7. "φA TERMINAL CLUSTER"

These are the input terminals for channel A (φA).

#### 5-1-8. "φB TERMINAL CLUSTER"

These are the input terminals for channel B (φB). These terminals are not installed in Models 2301/2301L.

#### 5-1-9. "φC TERMINAL CLUSTER"

These are the input terminals for channel C (φC). These terminals are not installed in Models 2301/2301L.

**Note:** Instruments manufactured after 1/1/93 have a fuse installed in-line with the Low Shunts (Ranges .2, .5, 1). This is a 5 Amp Fast-blo fuse. If problems are observed when using the Low Shunt, ensure that these fuses are not blown. Replace blown fuses with the exact replacement part only!

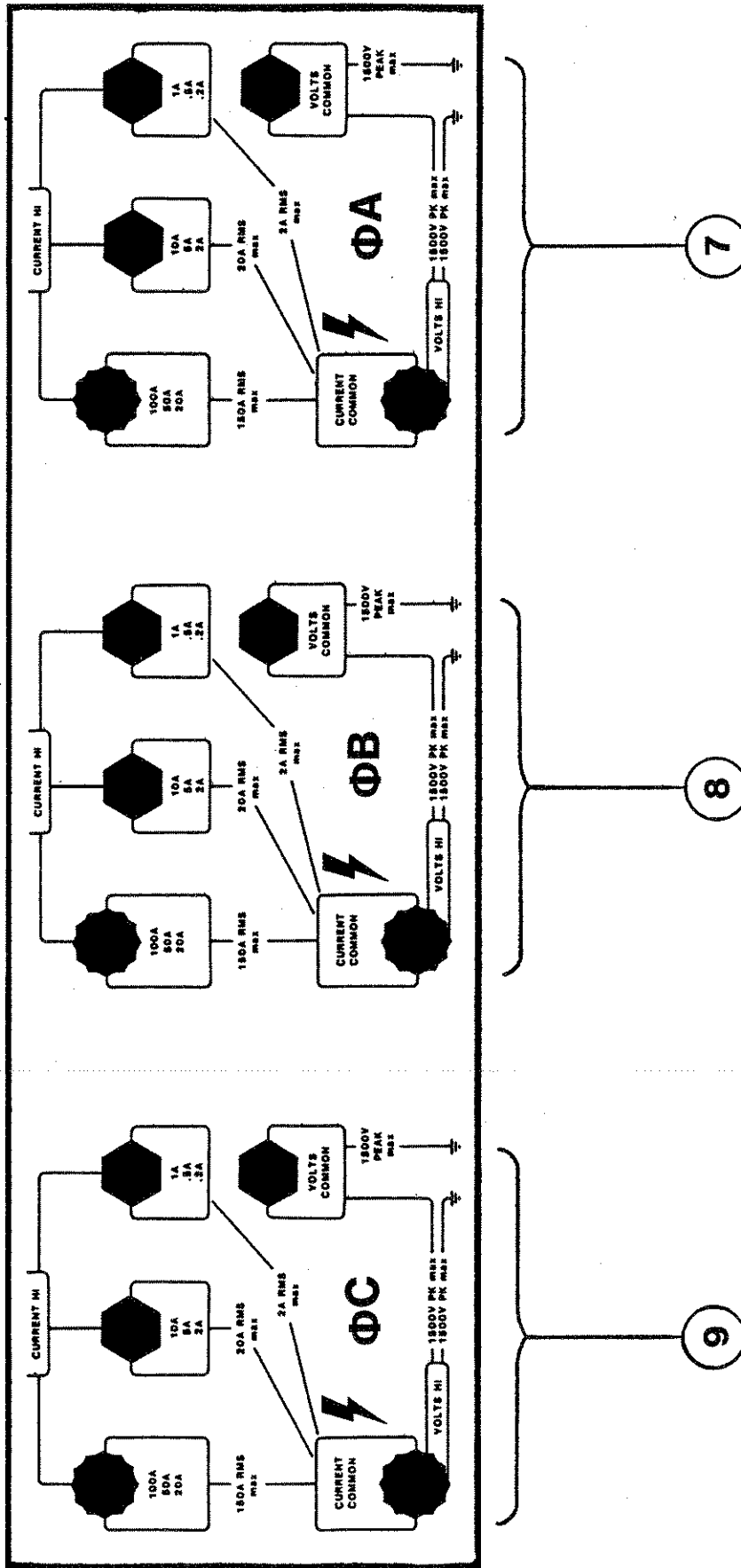


Figure 5-2. 2300 Shunt Terminals



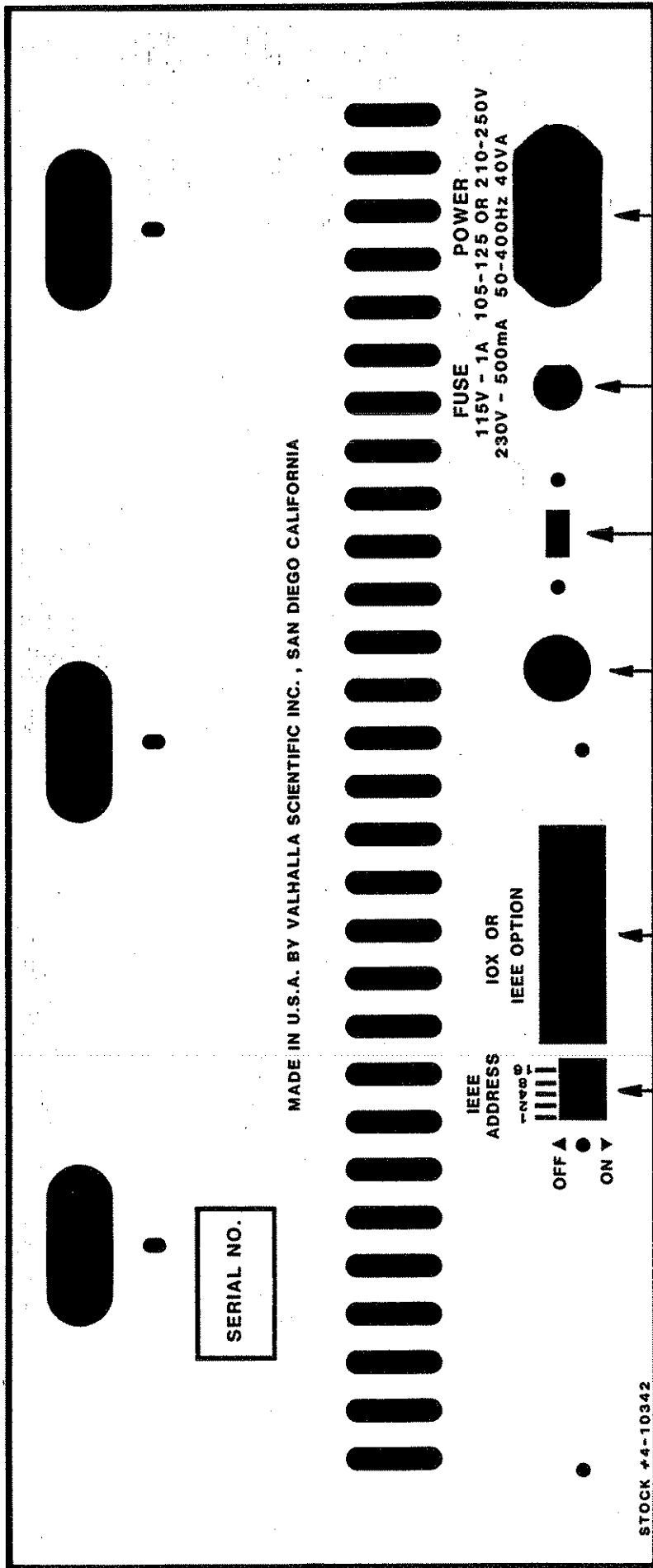
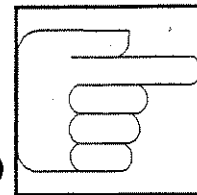


Figure 5-1. 2300 Rear Panel



## SECTION VI MANUAL OPERATION

---



### 6-1. General

The following paragraphs describe the manual operation of the 2300 series power analyzers and should be used along with Sections 4 and 5 for complete operating instructions. The user is advised to fully read these sections before attempting to operate the 2300. Section 7 describes operation via the IEEE-488 interface.

### 6-2. Safety Precautions

**CAUTION!!**

**IN NORMAL USE THE TERMINALS OF THE 2300 ARE CONNECTED TO LETHAL VOLTAGES. DEATH MAY OCCUR ON CONTACT!**

Do not attach or remove wires without first checking that all power sources have been disabled. Do not open-circuit the secondary windings of current transformers when they are energized. Lethal potentials may exist which can damage the transformer, the 2300, and the operator.

### 6-3. Operation

The 2300 contains three independent wattmeter channels (phases). Single-phase power may be measured using any of the three channels. Three simultaneous, independent, single-phase measurements may also be made.

When measuring three-phase power, the number of leads connected to the load determines how the 2300 is connected. If the load has three-wires, the two-wattmeter method is used to measure the total power. The total power is the sum of the two wattmeter readings. Phase B is

used as the reference (neutral) for the other channels.

Wattmeter channel A measures the current in phase A and the voltage between phase A and phase B. Channel C measures the current in phase C and the voltage between phase C and phase B. Phase B is not used other than as a reference. The 2300 sums the phase A and C power readings when the 3 $\phi$  3-WIRE mode is selected. The voltage and current displays are blanked in this mode as they are invalid. The individual line currents, line to line voltages and phase powers can be displayed by pressing the  $\phi A$  or  $\phi C$  push-buttons. A complete proof of the validity of the two wattmeter method is beyond the scope of this manual, and may be found in a college level electrical engineering textbook.

If the load has four-wires, all three wattmeters must be used to measure the total power. The total power is the sum of the three wattmeter readings. Channel A measures the current in phase A and the voltage between phase A and neutral. Channels B and C similarly measure phases B and C. The 2300 sums the phase A, B, and C readings when the 3 $\phi$  4-WIRE mode is selected. The voltage and current displays are blanked in this mode as they are invalid. The individual line voltages, currents, and powers may be displayed by pressing the  $\phi A$ ,  $\phi B$ , or  $\phi C$  display selection push-buttons.

### 6-4. Connections

The 2300 has a separate cluster of terminals for each of the three phases. Each channel has three current terminals, with use determined by the amount of current to be measured. The three current terminals are internally connected

to the 1 ampere, 10 ampere, or 100 ampere shunts. The opposite ends of the three shunts are connected together to the CURRENT COMMON - VOLTS HIGH terminal. The 2300 measures the voltage between the CURRENT COMMON - VOLTS HIGH terminal and the VOLTS COMMON terminal on all voltage ranges. Connections to the 2300 vary widely and most conceivable configurations are described in the following paragraphs. The paragraph numbers correspond to the Figure numbers at the end of this section. The single-phase connections are shown using channel C of the 2300. Any of the channels, A, B, or C may be used for single phase measurements.

#### 6-4-1. Single-Phase Two-Wire Load Power Connections

Connect the wattmeter as shown in Figure 6-1. **Caution!** Do not run the neutral current through the volts common terminal. Tap off the neutral wire to connect the volts common terminal.

#### 6-4-2. Single-Phase Two-Wire CT Load Power Connections

Connect the wattmeter as shown in Figure 6-2. Observe the polarities of the current transformer. The watts reading should be multiplied by the CT ratio. **Caution!** Do not run the load current through the VOLTS COMMON terminal. Tap off the neutral wire to connect the VOLTS COMMON terminal.

#### 6-4-3. Single-Phase Two-Wire PT Load Power Connections

Connect the wattmeter as shown in Figure 6-3. Observe the polarity of the potential transformer. The watts reading should be multiplied by the PT ratio. **Caution!** Do not exceed the common-mode rating of the Model 2300.

#### 6-4-4. Single-Phase Two-Wire CT-PT Load Power Connections

Connect the wattmeter as shown as Figure 6-4. Observe the polarities of the current and potential transformers. The watts reading should be multiplied by the PT and CT ratios. The current common terminal should be grounded for best performance.

#### 6-4-5. Single-Phase Two-Wire Source Power Connections

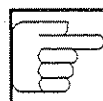
Some applications require measuring the power from a source rather than the power into the load. These connections are shown in Figure 6-5. When the model 2300 is connected in this manner, the watts reading should be multiplied by minus one (-1). **Caution!** Do not run the neutral current through the VOLTS COMMON terminal. Tap off the neutral wire to connect the VOLTS COMMON terminal.

#### 6-4-6. Single-Phase Two-Wire CT Source Power Connections

Some applications require measuring the power from a source rather than the power into the load. These connections are shown in Figure 6-6. When the Model 2300 is connected in this manner, the watts reading should be multiplied by minus one (-1) and the CT ratio. Observe the polarity of the current transformer. **Caution!** Do not run the neutral current through the VOLTS COMMON terminal. Tap off the neutral wire to connect the VOLTS COMMON terminal.

#### 6-4-7. Single-Phase Two-Wire PT Source Power Connections

Some applications require measuring the power from the source rather than the power into the load. These connections are shown in Figure 6-7. When the Model 2300 is



connected in this manner, the watts reading should be multiplied by minus one (-1) and the PT ratio. Observe the polarity of the potential transformer. **Caution!** Do not exceed the common-mode specification of the Model 2300.

#### **6-4-8. Single-Phase Two-Wire CT-PT Source Power Connections**

Some applications require measuring the power from a source rather than the power into the load. These connections are shown in Figure 6-8. When the Model 2300 is connected in this manner, the watts reading should be multiplied by minus one (-1) and the CT-PT ratios. Observe the polarities of the current and potential transformers. For best performance the CURRENT COMMON terminal should be grounded.

#### **6-4-9. Three-Phase Three-Wire Load Power Connections**

Connect the wattmeter as shown in Figure 6-9. **Caution!** Do not run phase B current through the VOLTS COMMON terminals. Tap off the phase B wire to connect the VOLTS COMMON terminals.

#### **6-4-10. Three-Phase Three-Wire CT Load Power Connections**

Connect the wattmeter as shown in Figure 6-10. Observe the polarities of the current transformers. The watts reading should be multiplied by the CT ratio. **Caution!** Do not run the line current through the CURRENT or VOLTS COMMON terminals.

#### **6-4-11. Three-Phase Three-Wire PT Load Power Connections**

Connect the wattmeter as shown in Figure 6-11. Observe the polarities of the potential transformers. The watts reading should be multiplied by the PT ratio.

**Caution!** Do not exceed the common-mode specifications of the Model 2300.

#### **6-4-12. Three-Phase Three-Wire CT-PT Load Power Connections**

Connect the wattmeter as shown in Figure 6-12. Observe the polarities of the current and potential transformers. The watts reading should be multiplied by the CT-PT ratios. For best performance ground the CURRENT COMMON terminals.

#### **6-4-13. Three-Phase Three-Wire Source Power Connections**

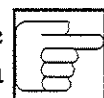
Some applications require measuring the power from a source rather than the power into the load. These connections are shown in Figure 6-13. When the Model 2300 is connected in this manner, the watts reading should be multiplied by minus one (-1). **Caution!** Do not run the phase B current through the VOLTS COMMON terminals. Tap off the phase B wire to connect the VOLTS COMMON terminals.

#### **6-4-14. Three-Phase Three-Wire CT Source Power Connections**

Some applications require measuring the power from a source rather than the power into the load. These connections are shown in Figure 6-14. When the model 2300 is connected in this manner, the watts reading should be multiplied by minus one (-1) and the CT ratio. Observe the polarity of the current transformer. **Caution!** Do not run the line current through the CURRENT or VOLTS COMMON terminal. Tap off the line wires to connect the CURRENT and VOLTS COMMON terminals.

#### **6-4-15. Three-Phase Three-Wire PT Source Power Connections**

Some applications require measuring the power from a





source rather than the power into a load. These connections are shown in Figure 6-15. When the Model 2300 is connected in this manner, the watts reading should be multiplied by minus one (-1) and the PT ratio. Observe the polarities of the potential transformers. **Caution!** Do not exceed the common-mode specifications of the Model 2300.

#### **6-4-16. Three-Phase Three-Wire CT-PT Source Power Connections**

Some applications require measuring the power from a source rather than the power into a load. These connections are shown in Figure 6-16. When the Model 2300 is connected in this manner, the watts reading should be multiplied by minus one (-1) and the CT-PT ratios. Observe the polarities of the current and potential transformers. For best performance, the CURRENT COMMON terminals should be grounded.

#### **6-4-17. Three-Phase Four-Wire Load Power Connections**

Connect the wattmeter as shown in Figure 6-17. **Caution!** Do not run the neutral current through the VOLTS COMMON terminals. Tap off the neutral wire to connect the VOLTS COMMON terminals.

#### **6-4-18. Three-Phase Four-Wire CT Load Power Connections**

Connect the wattmeter as shown in Figure 6-18. Observe the polarities of the current transformers. The watts reading should be multiplied by the CT ratio. **Caution!** Do not run the line or neutral currents through the CURRENT or VOLTS COMMON terminals.

#### **6-4-19. Three-Phase Four-Wire PT Load Power Connections**

Connect the wattmeter as shown in Figure 6-19. Observe the polarities of the

potential transformers. The watts reading should be multiplied by PT ratio. **Caution!** Do not exceed the common mode specifications of the Model 2300.

#### **6-4-20. Three-phase Four-Wire CT-PT Load Power Connections**

Connect the wattmeter as shown in Figure 6-20. Observe the polarities of the current and potential transformers. The watts reading should be multiplied by CT-PT ratios. For best performance, ground the CURRENT COMMON terminals.

#### **6-4-21. Three-phase Four-Wire Source Power Connections**

Some applications require measuring the power from a source rather than the power into a load. These connections are shown in Figure 6-21. When the Model 2300 is used in this manner, the watts reading should be multiplied by minus one (-1). **Caution!** Do not run the neutral current through the VOLTS COMMON terminals. Tap off the neutral wire to connect to the VOLTS COMMON terminals.

#### **6-4-22. Three-phase Four-Wire CT Source Power Connections**

Some applications require measuring the power from a source rather than the power into a load. These connections are shown in Figure 6-22. When the Model 2300 is used in this manner, the watts reading should be multiplied by minus one (-1) and the CT ratio. Observe the polarities of the current transformers. **Caution!** Do not run the line or neutral currents through the VOLTS COMMON terminals. Tap off the line and neutral wires to connect the VOLTS COMMON terminals.



#### 6-4-23. Three-phase Four-Wire PT Source Power Connections

Some applications require measuring the power from a source rather than the power into a load. These connections are shown in Figure 6-23. When the Model 2300 is used in this manner, the watts reading should be multiplied by minus one (-1) and the PT ratio. Observe the polarities of the potential transformers. **Caution!** Do not exceed the common mode specifications of the Model 2300.

#### 6-4-24. Three-phase, Four-Wire CT-PT Source Power Connections

Some applications require measuring the power from a source rather than the power into a load. These connections are shown in Figure 6-24. When the Model 2300 is used in this manner, the watts reading should be multiplied by minus one (-1) and the CT-PT ratios. Observe the polarity of the current and potential transformers. For best performance the CURRENT COMMON terminals should be grounded.

#### 6-5. Single-Phase Measurements


The power consumed by a single-phase load or the power supplied by a single-phase source may be easily measured with a Model 2300 or 2301. Three independent single-phase measurements can be made at the same time with the 2300. The following guidelines should be used when making a single-phase power measurement:

- 1) Connect the 2300 as shown in Figures 6-1 to 6-8 as determined by your application. Make connections to the appropriate current shunt terminal for the expected range of current levels.
- 2) Press the appropriate  $\phi A$ ,  $\phi B$ , or  $\phi C$  display selection push-button for the channel connected.

- 3) Select the lowest current range that provides the required display resolution without the current peak overload LED illuminating.
- 4) Select the lowest voltage range that provides the required display resolution without the voltage peak overload LED illuminating.
- 5) Read the voltage, current and power on the three displays. When measuring the power supplied by a source, multiply the power measurement by negative one (-1) to obtain the correct watts polarity.
- 6) The displays may be frozen indefinitely by pressing the HOLD push-button.

#### 6-6. Three-Phase Three-Wire Measurements

The power consumed by a three-phase three-wire connected load or the power supplied by a three-phase three-wire connected source may easily be measured with a Model 2300. The following guidelines should be used when making three-phase three-wire measurements:

- 1) Connect the 2300 as shown in Figures 6-9 to 6-16 as determined by your application. Make connections to the appropriate current shunt terminals for the expected range of current levels.
- 2) Press the 3 $\phi$  3-WIRE display selection push-button.
- 3) Select the lowest current range without illuminating any of the peak current overload indicators.
- 4) Select the lowest voltage range without illuminating any of the peak voltage indicators.
- 5) The total true power may be read on the watts display. 

When measuring the power supplied by a source, multiply the power measurements by negative one (-1) to obtain the correct watts polarity.

- 6) The individual phase voltages, currents, and power can be displayed by pressing the  $\phi A$  and  $\phi C$  display selection push-buttons.
- 7) The displays may be frozen indefinitely by pressing the HOLD push-button.

#### 6-7. Three-phase, Four-wire Measurements

The power consumed by a three-phase four-wire connected load or the power supplied by a three-phase four-wire connected source can easily be measured with a 2300. Follow the guidelines below for making three-phase four-wire measurements with the Model 2300:

- 1) Connect the 2300 as shown in Figures 6-17 to 6-24 as determined by your application. Make connections to the appropriate current shunt terminals for the expected range of current levels.
- 2) Press the  $3\phi$  4-WIRE display selection push-button.
- 3) Select the lowest current range that does not illuminate any of the peak current indicators.

- 4) Select the lowest voltage range that does not illuminate any of the peak voltage indicators.

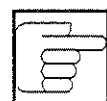
- 5) Read the total power on the watts display. When measuring the power supplied by a source, multiply the power measurements by negative one (-1) to obtain the correct watts polarity.

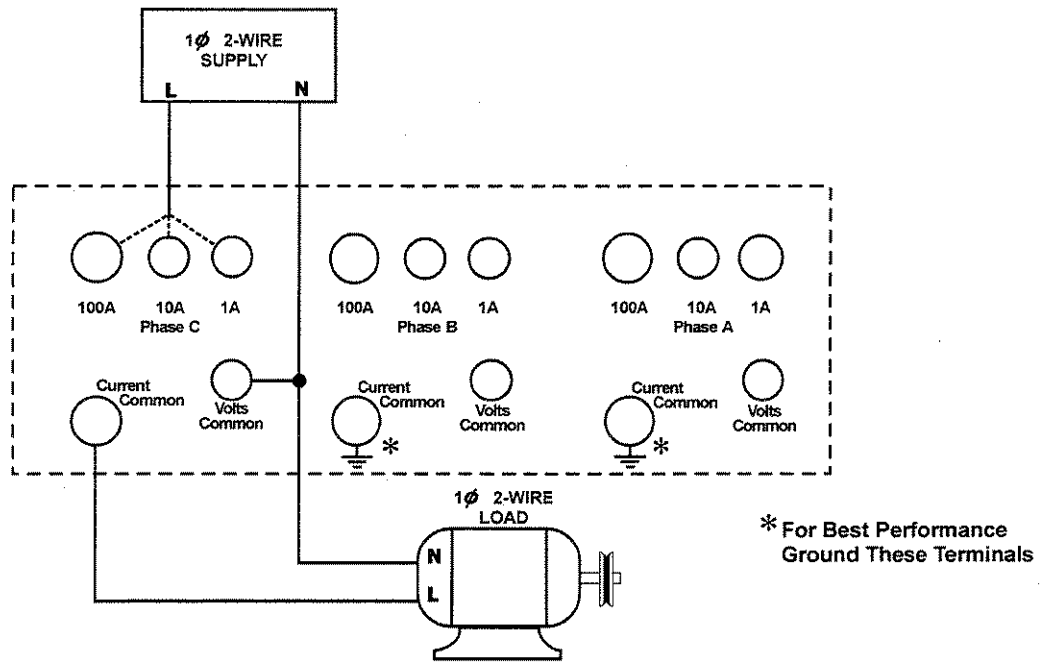
- 6) The individual phase voltages, currents, and powers may be displayed by pressing the  $\phi A$ ,  $\phi B$  and  $\phi C$  display selection push-buttons.

- 7) The displays may be frozen indefinitely by pressing the HOLD push-button.

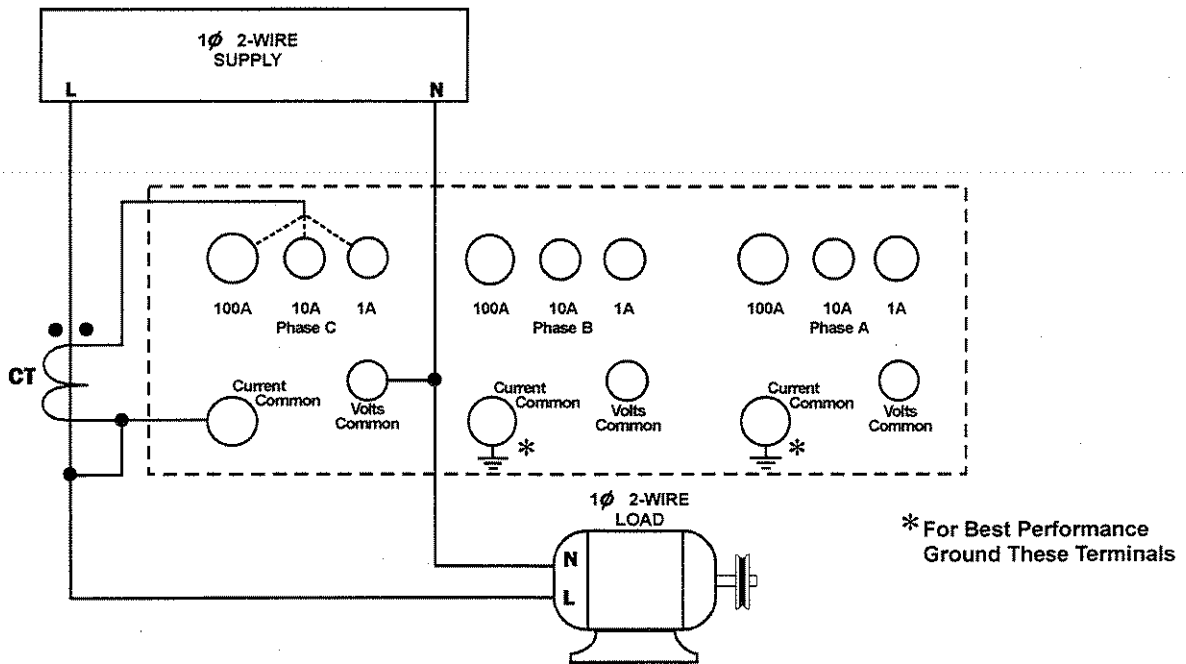
#### 6-8. Other Applications

If your measurement requirement or application was not discussed in the preceding paragraphs, also refer to the Application Notes of Section 11.

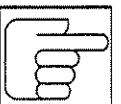




**Figure 6-1. Single-Phase Two-Wire Load Power Connections**



**Figure 6-2. Single-Phase Two-Wire CT Load Power Connections**



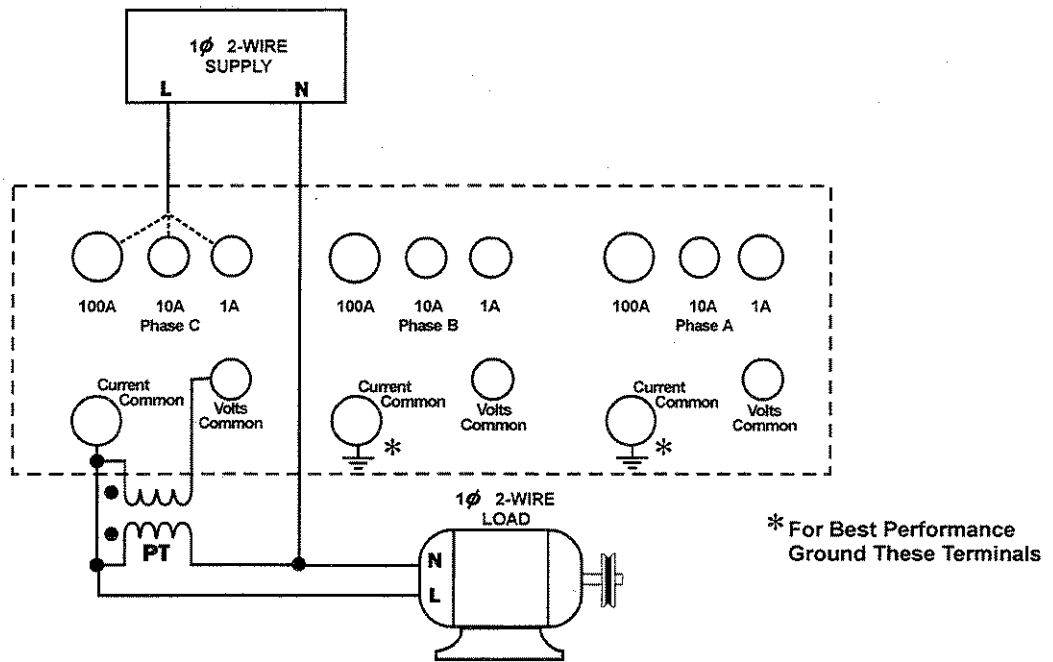


Figure 6-3. Single-Phase Two-Wire PT Load Power Connections

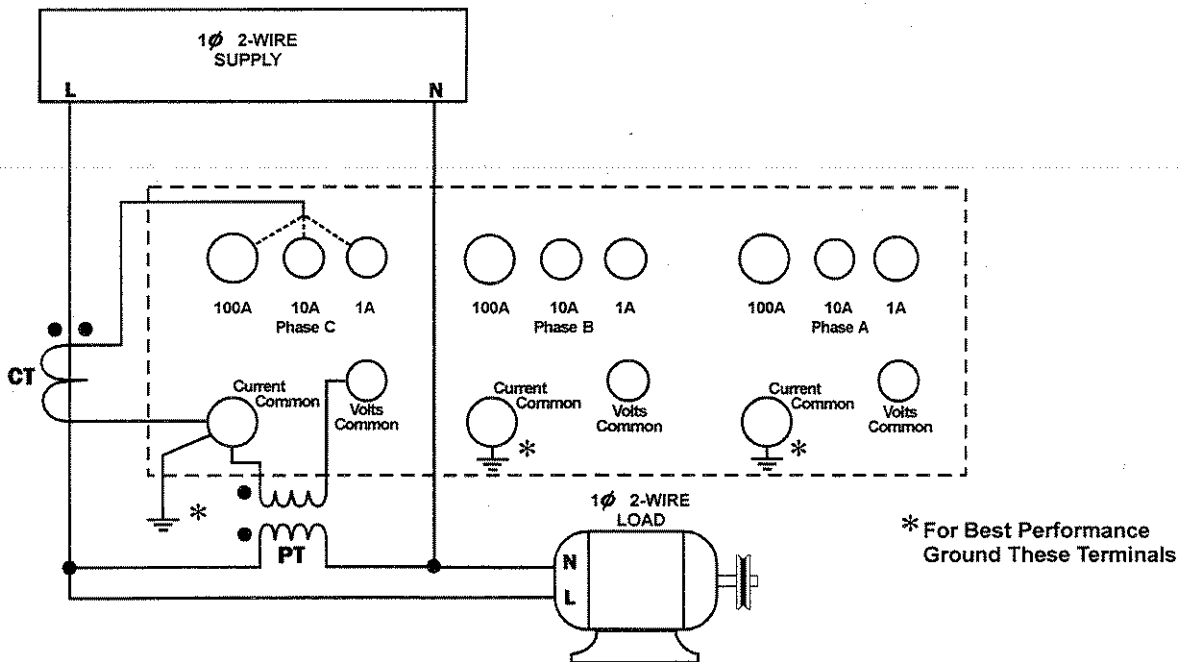
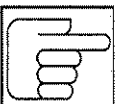


Figure 6-4. Single-Phase Two-Wire CT-PT Load Power Connections



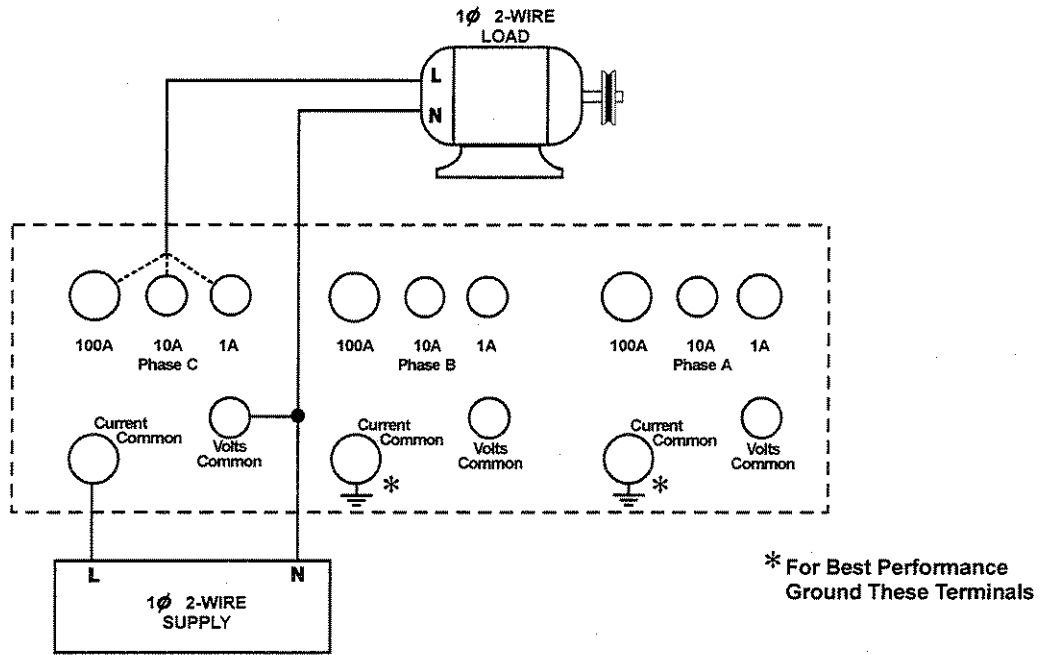


Figure 6-5. Single-Phase Two-Wire Source Power Connections

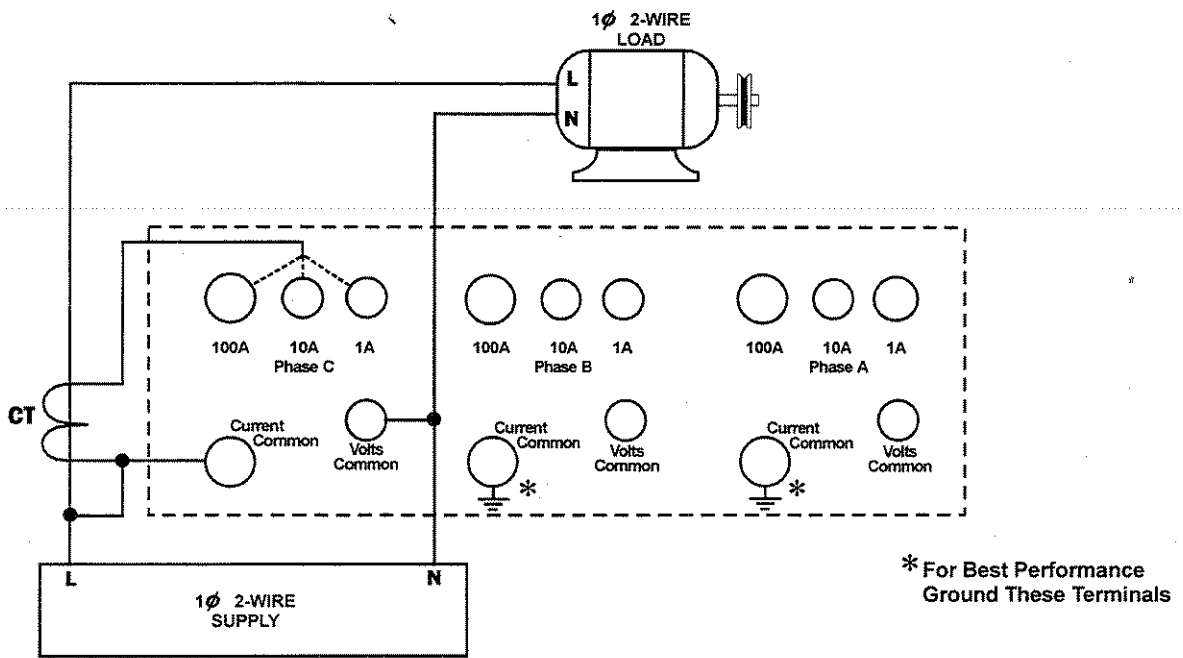
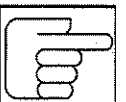
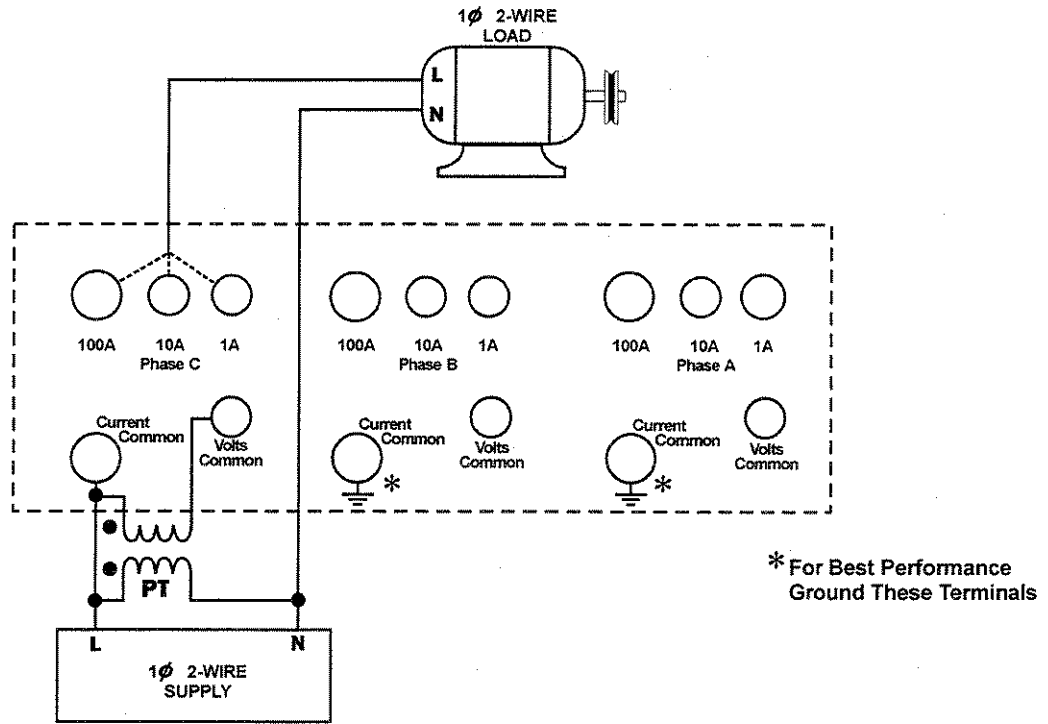
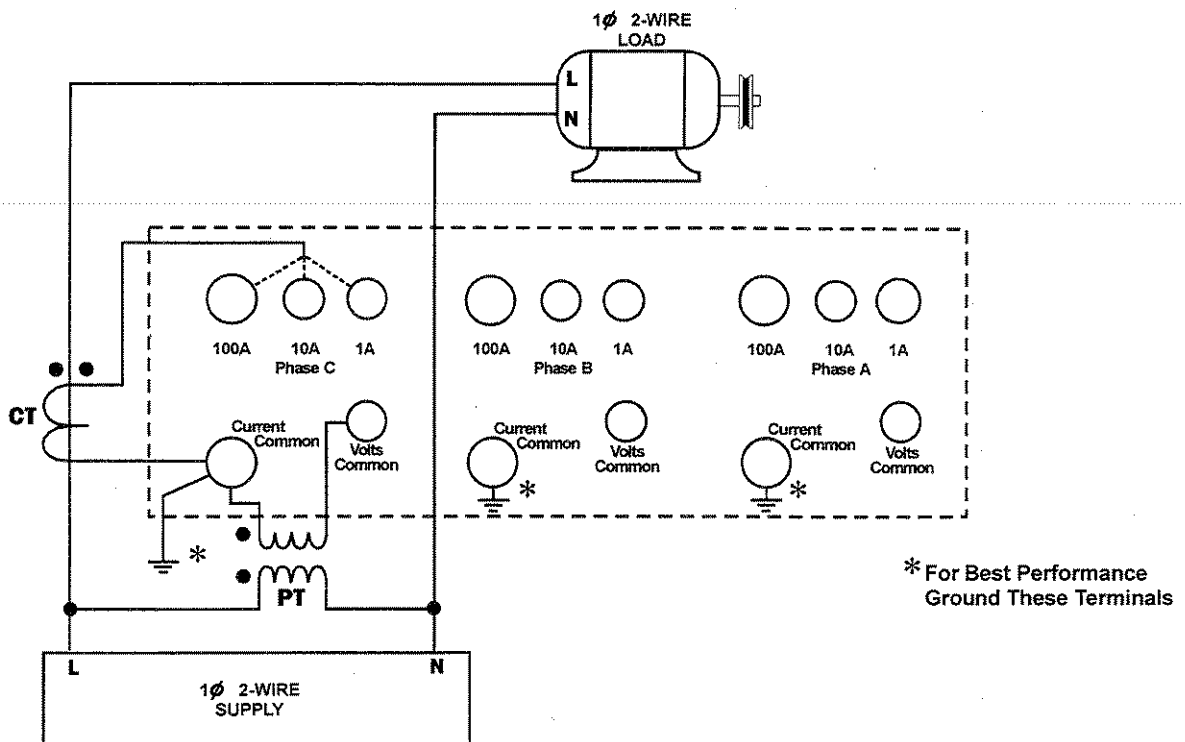


Figure 6-6. Single-Phase Two-Wire CT Source Power Connections

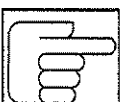




**Figure 6-7. Single-Phase Two-Wire PT Source Power Connections**



**Figure 6-8. Single-Phase Two-Wire CT-PT Source Power Connections**



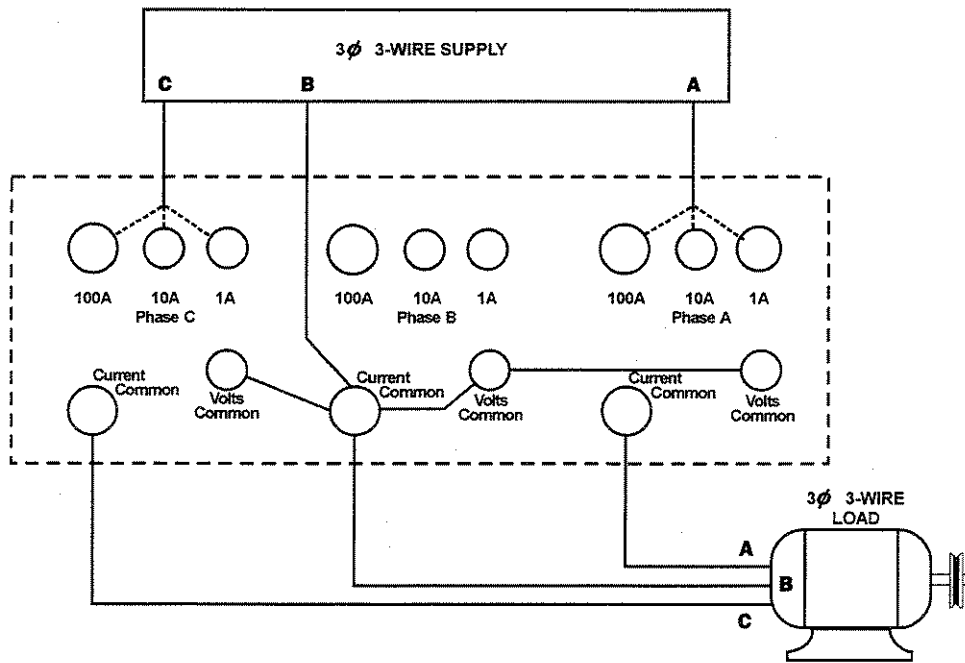


Figure 6-9. Three-Phase Three-Wire Load Power Connections

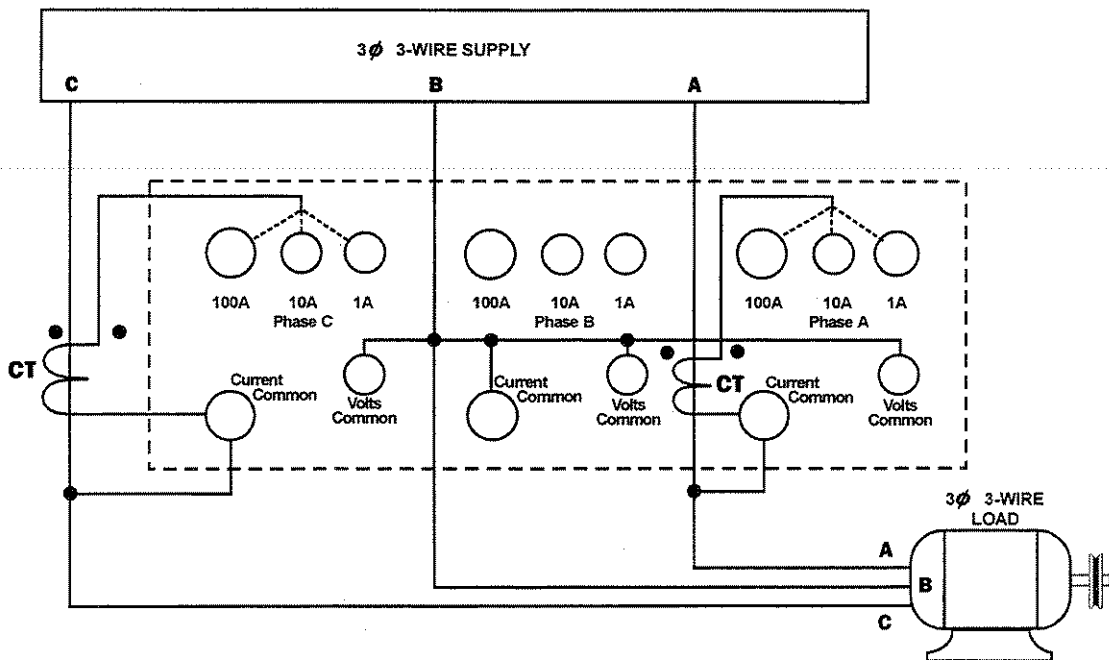
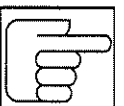


Figure 6-10. Three-Phase Three-Wire CT Load Power Connections





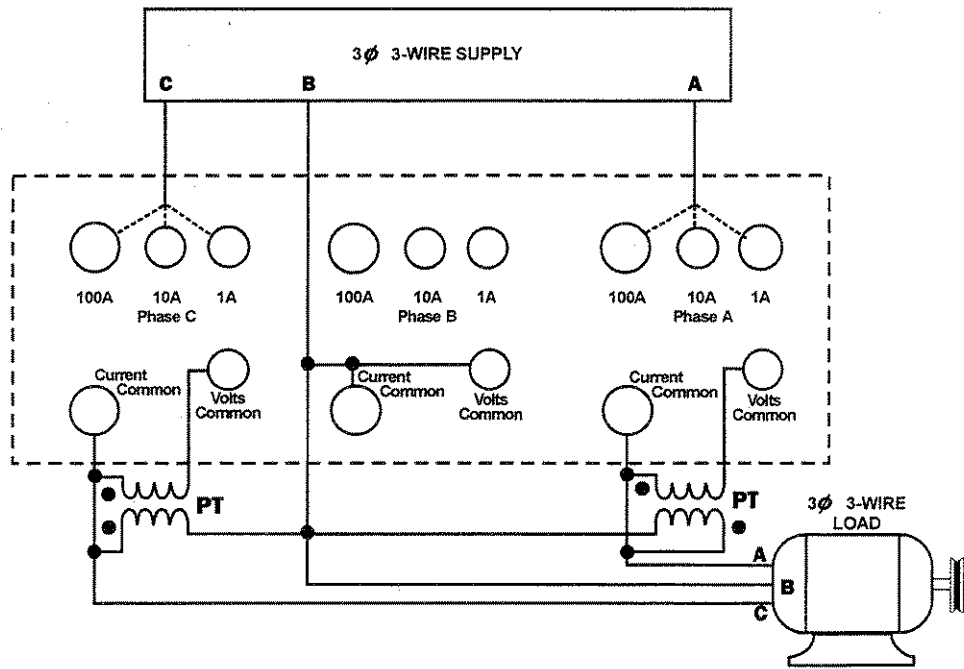


Figure 6-11. Three-Phase Three-Wire PT Load Power Connections

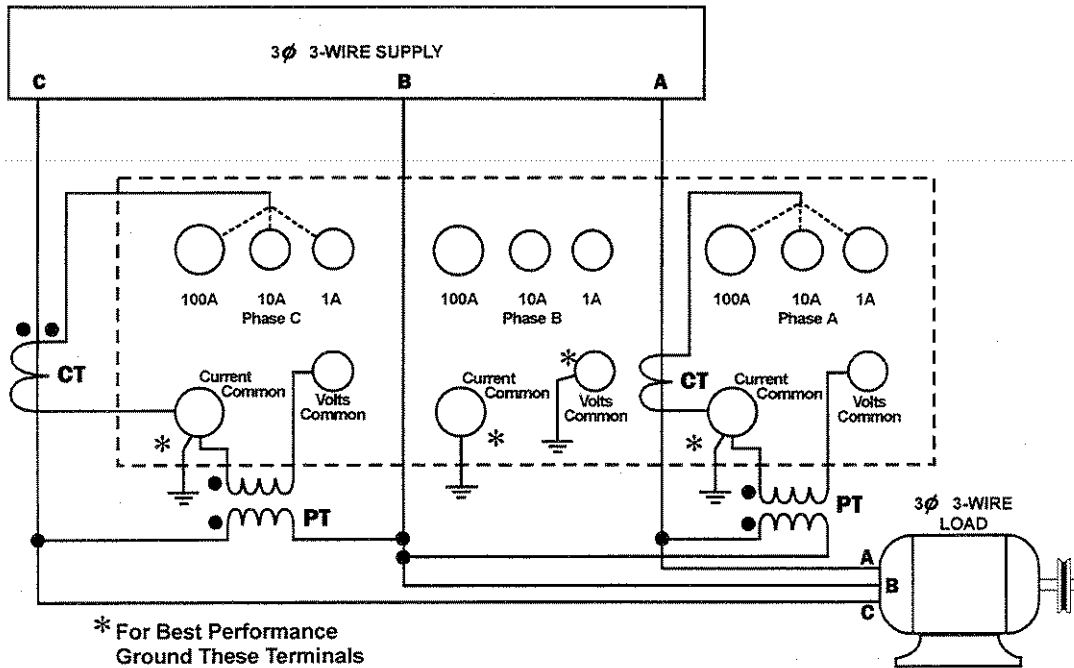


Figure 6-12. Three-Phase Three-Wire CT-PT Load Power Connections



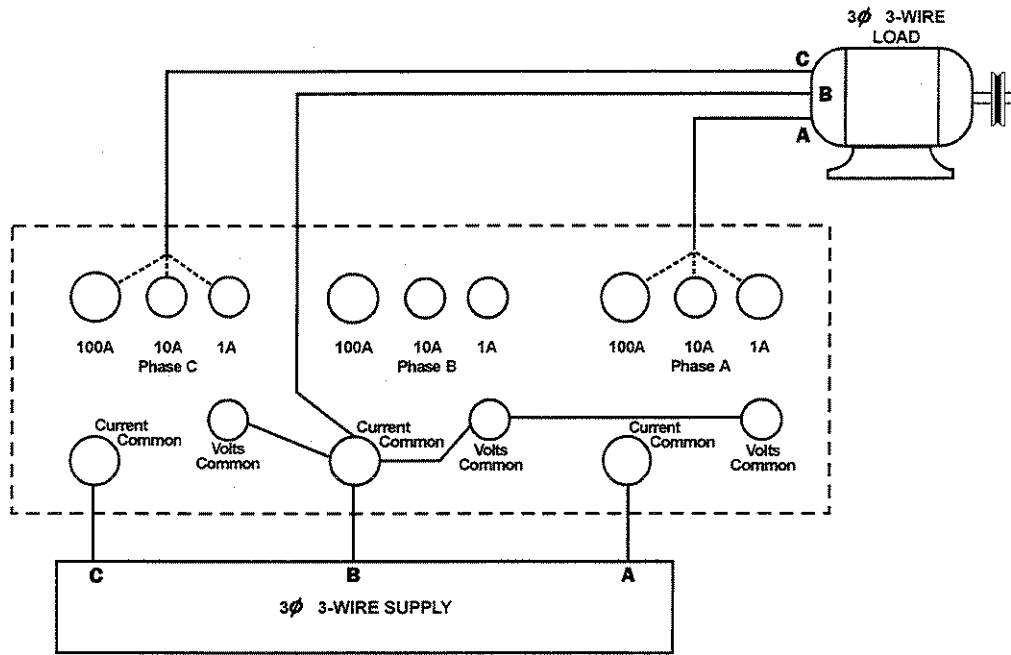


Figure 6-13. Three-Phase Three-Wire Source Power Connections

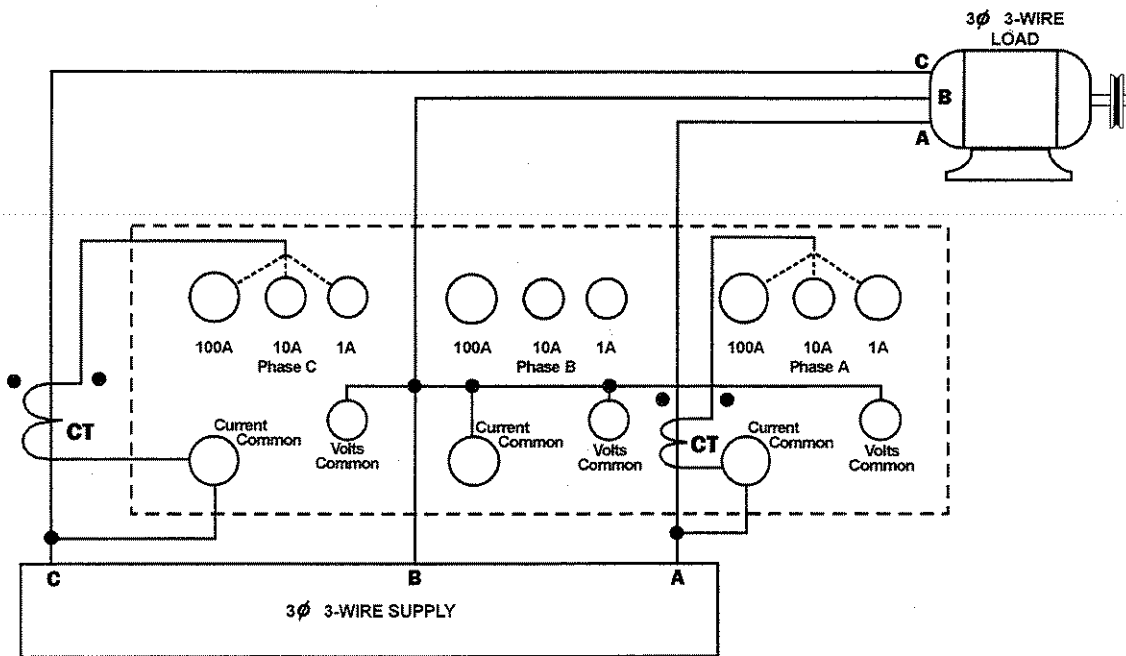
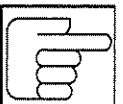


Figure 6-14. Three-Phase Three-Wire CT Source Power Connections



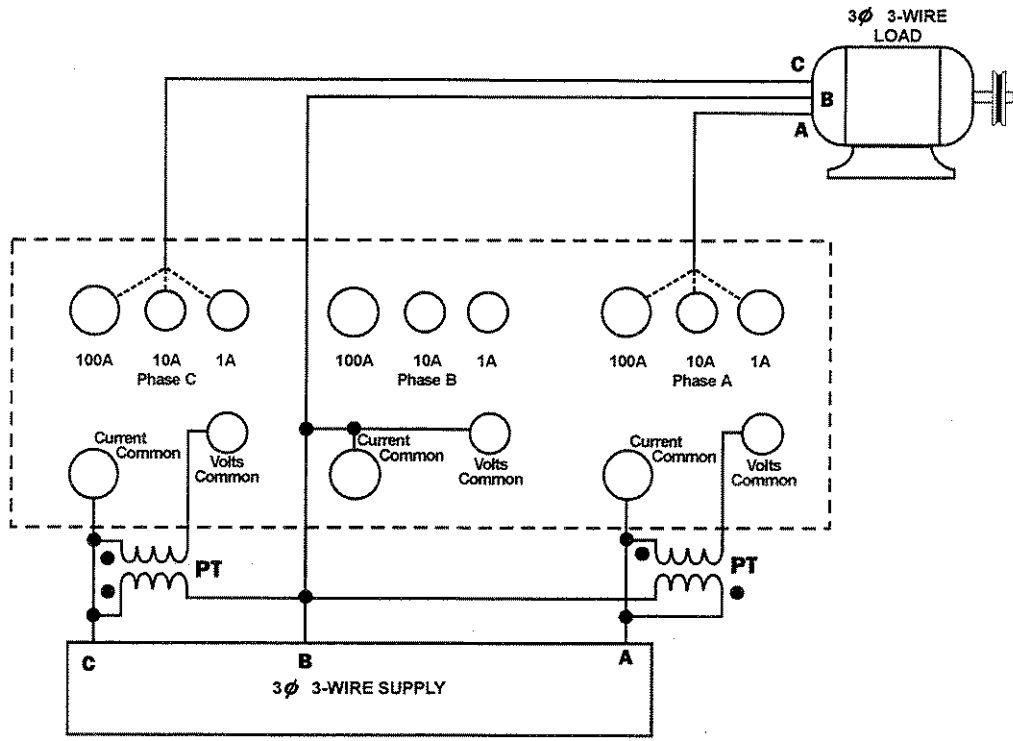


Figure 6-15. Three-Phase Three-Wire PT Source Power Connections

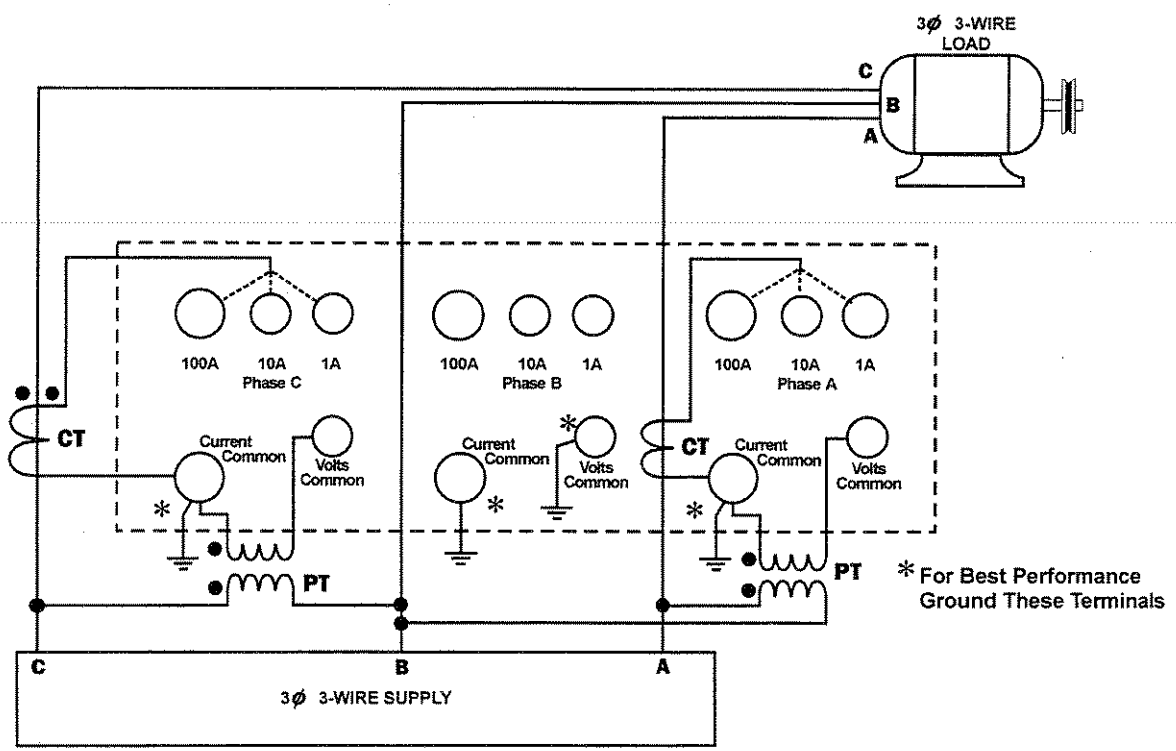
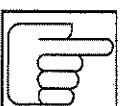


Figure 6-16. Three-Phase Three-Wire CT-PT Source Power Connections



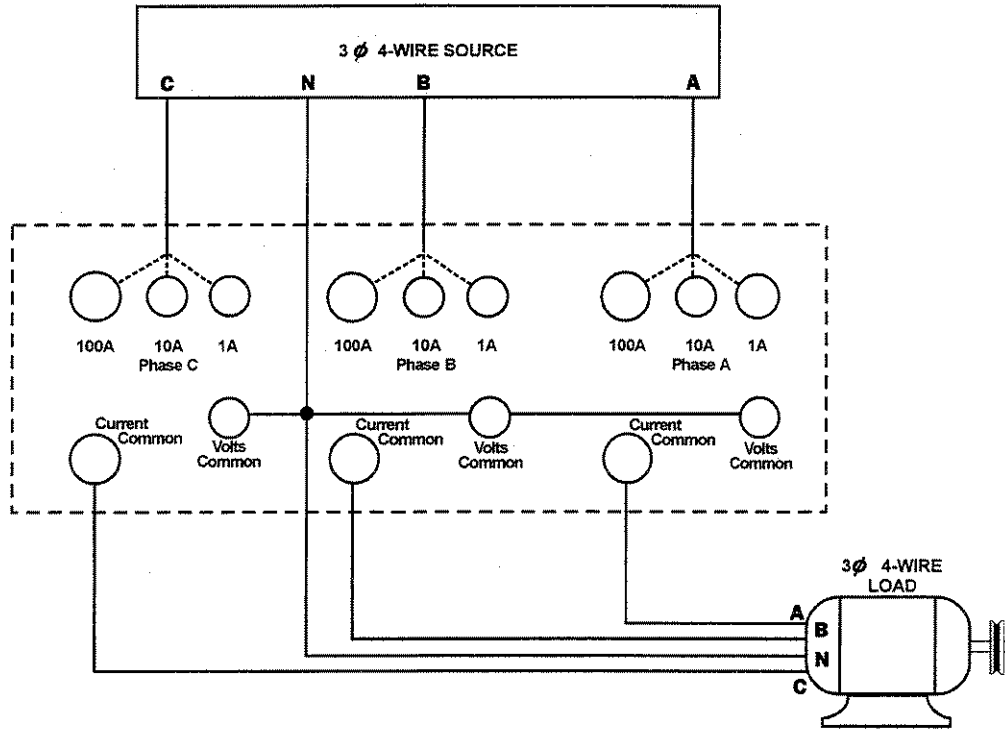


Figure 6-17. Three-Phase Four-Wire Load Power Connections

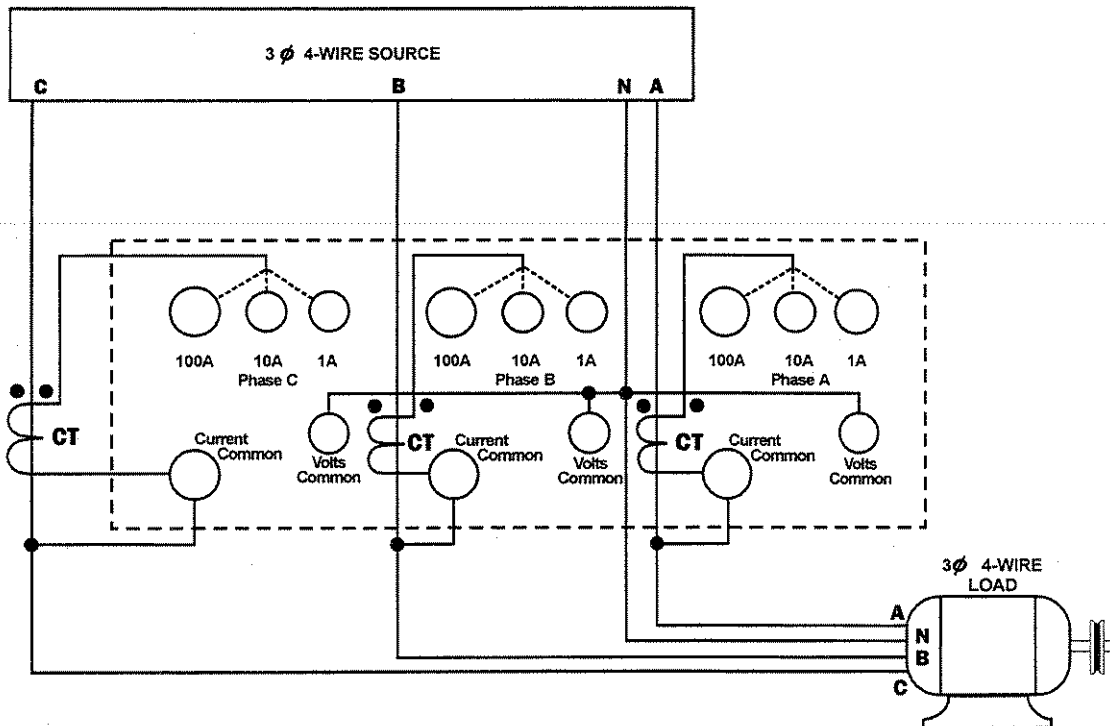
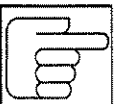


Figure 6-18. Three-Phase Four-Wire CT Load Power Connections



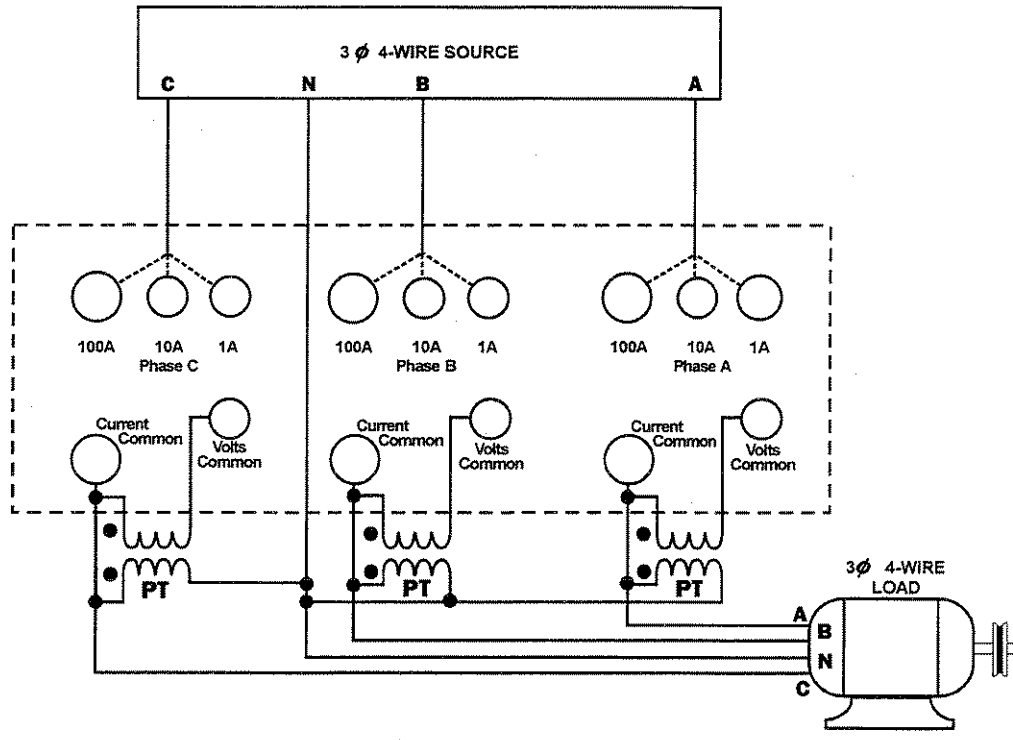


Figure 6-19. Three-Phase Four-Wire PT Load Power Connections

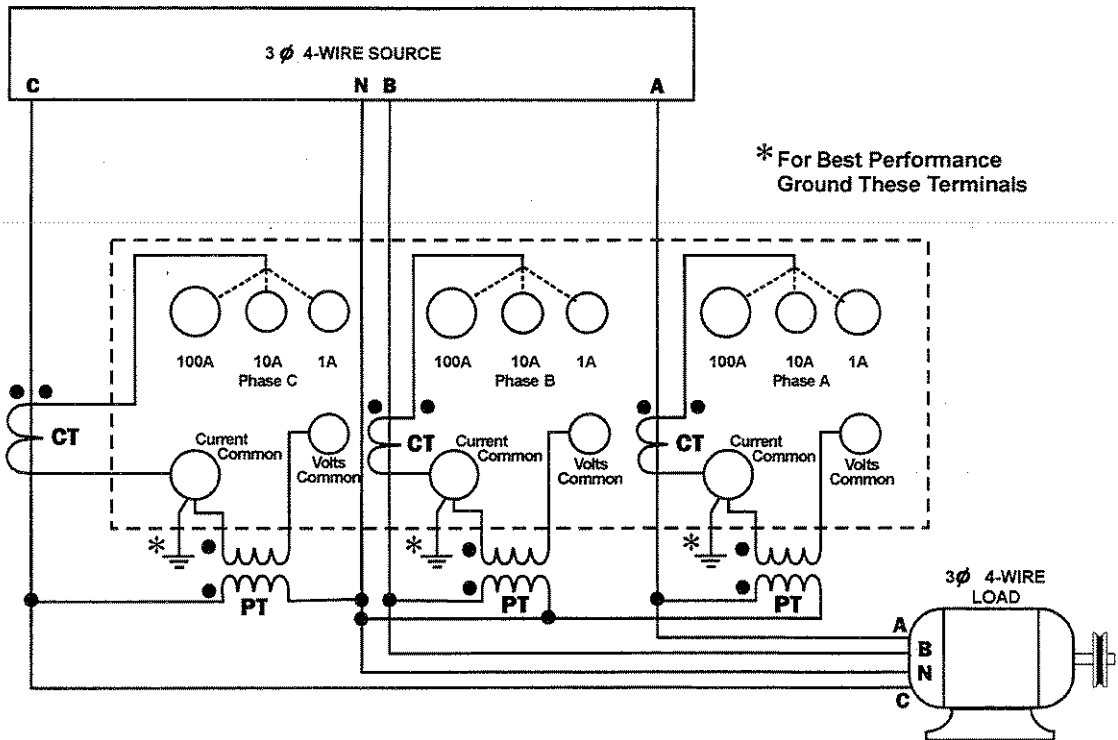
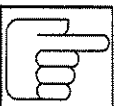


Figure 6-20. Three-Phase Four-Wire CT-PT Load Power Connections



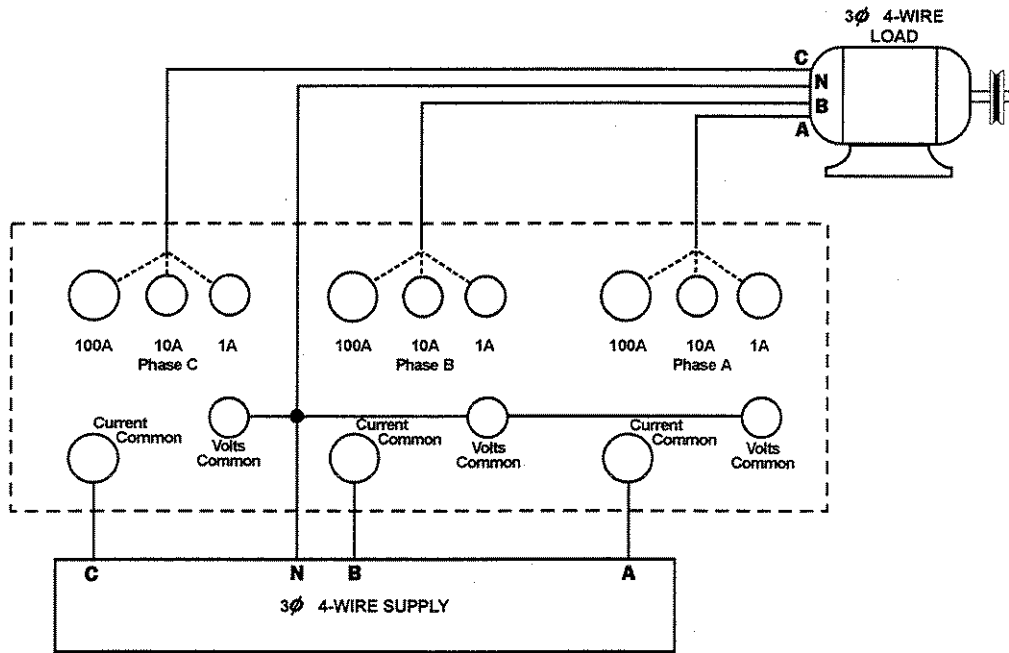


Figure 6-21. Three-Phase Four-Wire Source Power Connections

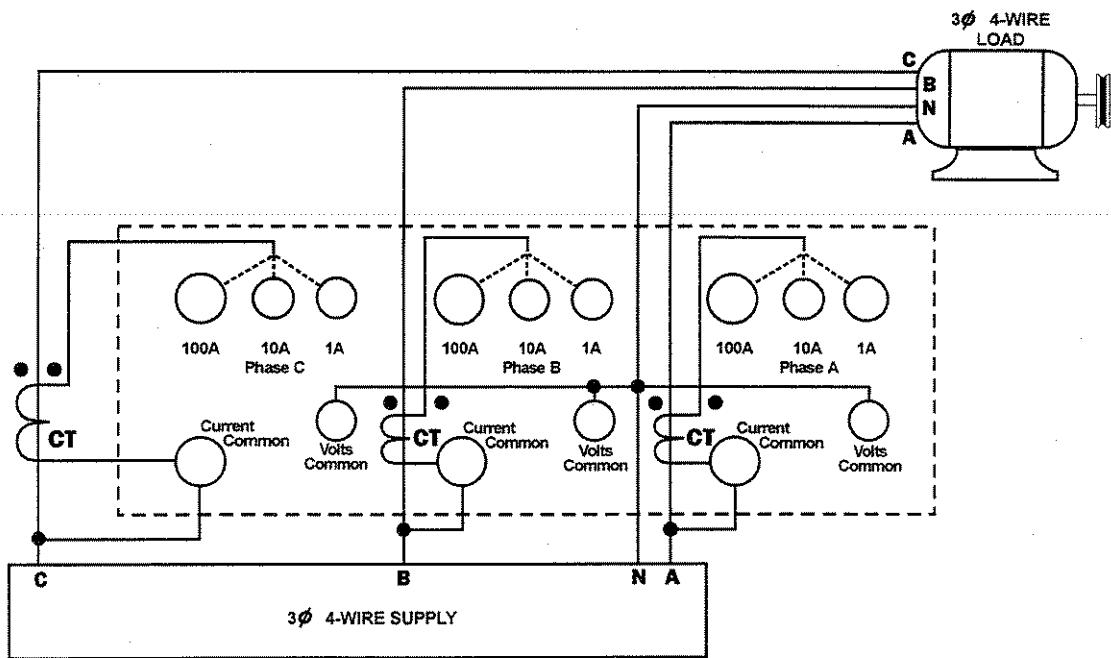
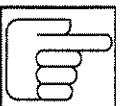


Figure 6-22. Three-Phase Four-Wire CT Source Power Connections



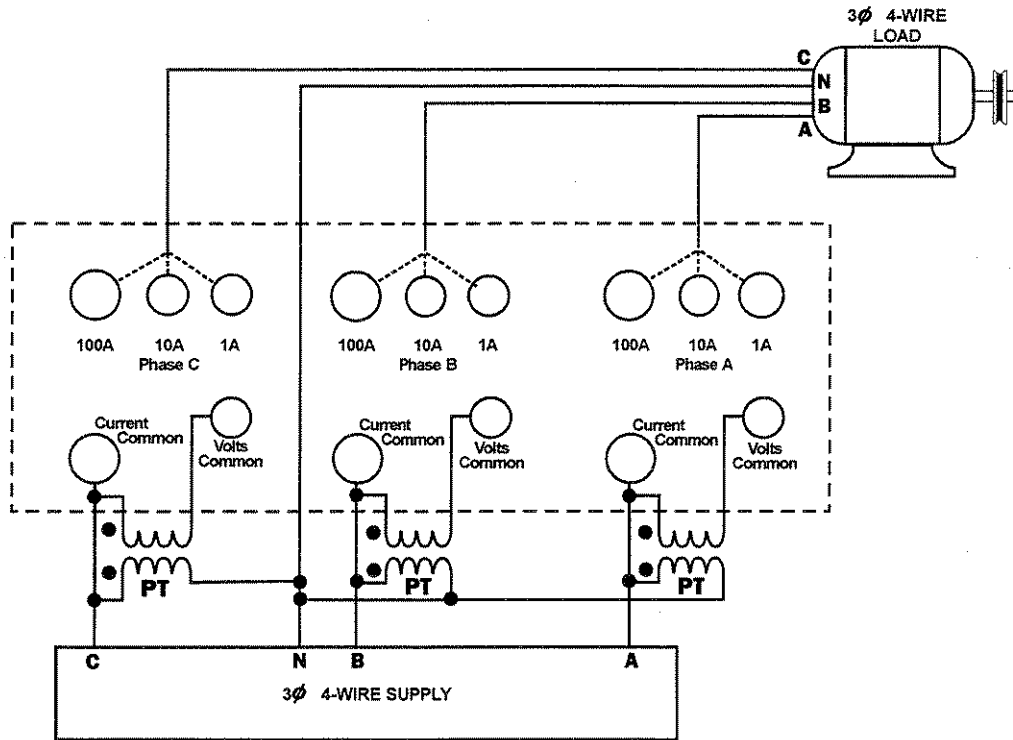


Figure 6-23. Three-Phase Four-Wire PT Source Power Connections

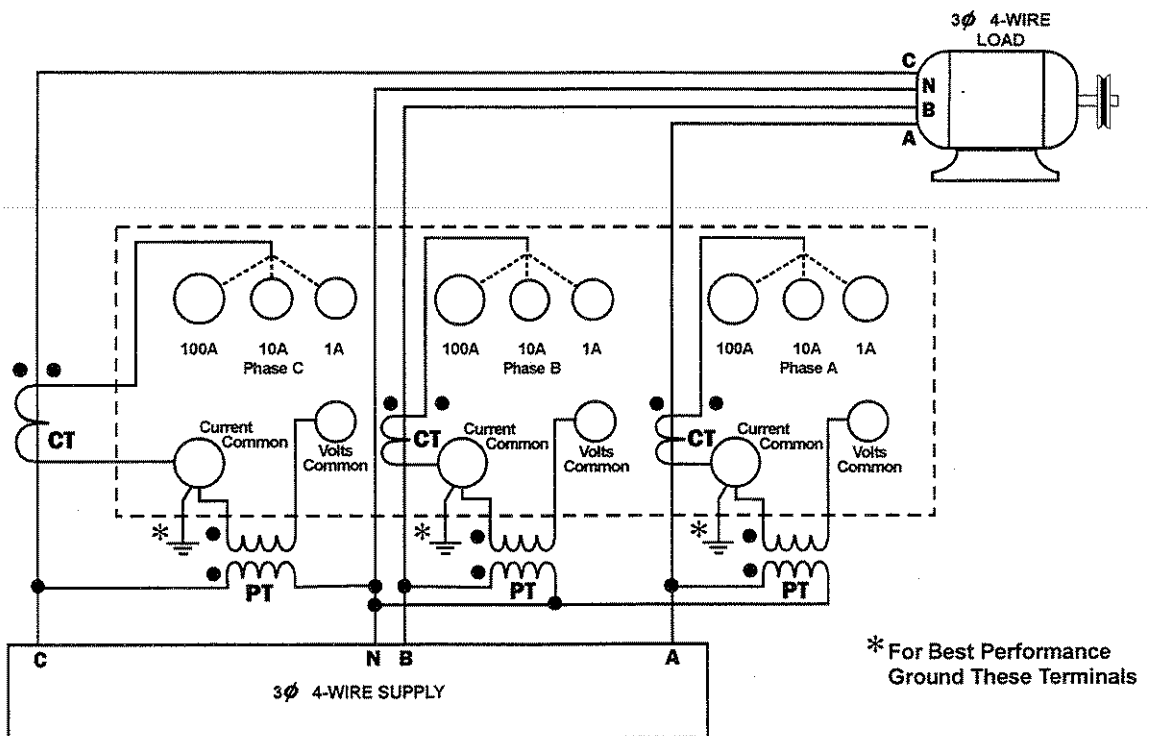
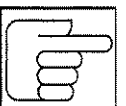
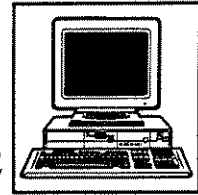


Figure 6-24. Three-Phase Four-Wire CT-PT Source Power Connections



## SECTION VII REMOTE OPERATION

---



### 7-1. General

This section describes the operation of the 2300 Series of Power Analyzers via the optional IEEE-488 interface bus. It is assumed throughout this section that the user has read Sections 4 through 6 and is familiar with the manual operation of the 2300.

### 7-2. Definitions

The following are definitions of the terms used in describing the IEEE-488 interface and its operation in the 2300.

**Bus:** A data link which is usually a set of several parallel wires within a multi-wire cable.

**Bi-directional Bus:** A "highway" used for two-way communication between two devices, with input and output data being carried on the same wires.

**Bit parallel:** A data transmission method in which all of the bits composing an item of data are present simultaneously on a group of wires in a bus.

**Byte:** A group of 8 data bits which are treated as a single item of data.

**Byte serial:** A data transmission method in which information, in bit parallel bytes, is transferred sequentially between devices.

**Device:** A unit or controller connected to the bus.

**Device dependent message:** A message containing information or commands having meaning only to the recipient device (usually refers to commands which

are not defined in IEEE Standard 488 of 1978).

**Handshake:** An exchange of signals between two devices which is usually used to control the transfer of data between them.

**Interface message:** A message intended for interface or bus management.

**Local operation:** Operation of a device by its front panel controls or other form of manual operation.

**Remote operation:** Operation of a device under the control of another via the bus.

### 7-3. Basic Description of the Bus

This chapter gives a basic description of the general principles of the IEEE-488 (1978) bus (also known as GPIB, HP-IB, IEC DTC-66, ANSI MCI-1 etc.) The user is recommended to read the full IEEE-488 standard for more details if required.

#### 7-3-1. The Purpose of the IEEE-488 Standard

The purpose of the standard is to allow for interconnection of programmable instruments with a minimum of engineering. The intent is to remove the need for adapters and numerous types of patching cables often encountered with other forms of interfaces. The IEEE-488 standard defines a system configuration for programmable instruments: calculators, voltmeters and other types of peripheral devices produced by various manufacturers, providing a set of rules for establishing a defined communications link with a high degree of compatibility yet maintaining flexibility between



independently manufactured products. The IEEE-488 (1978) standard defines the following:

Electrical characteristics - interface circuit parameters, electrical signal levels, loading requirements and grounding requirements.

Mechanical characteristics - connector type, contact assignments and cable assembly.

Functional characteristics - the complete repertoire and precise definition of each of the signal lines, the protocol and timing relationships and the mandatory responses for universal (device independent) messages.

The IEEE-488 (1978) standard does *not* define the following:

The way in which device dependent messages will be interpreted by the receiving device, leaving these up to the manufacturer to define. These are defined for the 2300 in Section 7-7.

Maximum amount of time for a full handshake of data to occur ensuring compatibility with the slowest device on the bus (it does define the minimums, however).

### 7-3-2. IEEE-488 Defined Parameters

The IEEE-488 standard defines a bi-directional bus carrying bit-parallel, byte-serial data. The most basic of its definitions are as follows:

All bus data is digital.

A maximum of 15 devices may be interconnected on a single bus.

The total length of the bus cabling may not exceed 20 meters, with a maximum interconnection cable length of 4 meters.

The maximum data transmission rate is 1 megabyte per second.

Of all the devices on the bus only one may be the controller at any time. The controller exercises control over all other devices on the bus. The other devices may be listeners (only able to receive data), talkers (only able to transmit data), or both. The 2300 functions both as a talker and as a listener. The controller is the only device capable of addressing other devices on the bus and commanding them to talk or listen as required. Only one device may talk at any one time.

The interconnecting cable shall consist of 16 signal wires and eight ground returns linking devices into a complete system (the user is cautioned to be careful of generating ground loops when interconnecting devices via the bus). Each cable connector is a plug and socket combination to permit the "daisy chaining" of devices.

The 16 signal wires are as follows:

8 data wires (DIO0 through DIO7 inclusive).

5 management wires (ATN, EOI, SRQ, IFC and REN).

3 handshake wires (DAV, NRFD and NDAC).

It should be noted that all of these wires use "inverse logic", i.e. a low voltage level indicates the "true" state (also called "asserted") while the high voltage level indicates the "false" state.

DIO (0 to 7) - These wires are the bi-directional data bus.

ATN - This wire may be asserted by the controller to indicate that an address or command is present on the bus.



EOI - This wire may be asserted by the controller or the talker. If ATN is also asserted this indicates that the controller is polling devices. If ATN is false, EOI may be asserted by a talker to indicate the end of a message.

SRQ - This wire may be asserted by any device to indicate that it requires attention (e.g. a fault has occurred or data is ready). Usually the controller will respond by polling the devices to determine which requires service.

IFC - This wire is asserted by the controller to reset the bus (note that only the bus is affected) to an idle state.

REN - This wire is asserted by the controller to indicate to all devices that they may enter the REMOTE state. The user should note that for a device to enter remote the REN wire must be asserted and the device must subsequently receive its listen address. If this wire is not asserted then all devices will be in the LOCAL state.

DAV - This wire is asserted by the talker and indicates that a valid data byte has been placed on the DIO0 to DIO7 wires.

NRFD - This wire may be asserted by any listener and indicates that it is not yet ready to receive further data.

NDAC - This wire may be asserted by any listener and indicates that it has not yet completed reading the data byte present on the DIO wires.

#### 7-4. Universal Commands

This paragraph describes all of the IEEE-488 defined commands and their affect upon the operation of the 2300. In this paragraph (as in all further paragraphs) examples are given using HP Basic and it is assumed that the 2300 has its listen address set to 15. If you are using a

programming language other than HP Basic, consult your programmer's guide for the correct command syntax.

##### 7-4-1. Device Clear (DCL)

This command will cause all of the devices to enter the reset state (both interface and instrumental functions). The 2300 will perform a power-on reset cycle when this command is received. An example of this command in HP Basic is **CLEAR 7**.

This command can sometimes cause the interface to reset and then re-read the device clear command if the responding instrument is slow to release the handshake. This will be visible as a complete bus lockout with all of the devices continuously performing a device clear. Although every precaution has been taken to eliminate this problem with the IEEE-488 Standard, lockout may sometimes occur. It is recommended the Selective Device Clear (SDC) Command be used where possible.

##### 7-4-2. Selective Device Clear (SDC)

This command will cause only the addressed device to enter the reset state. This command will perform the same function as the DCL command of 7-4-1 but on individual instruments only, thus overcoming the problem inherent with the DCL command.

An example of this command in HP Basic is **CLEAR 715** which would reset only the device at address 15.

##### 7-4-3. Group Execute Trigger (GET)

The execution of this command is dependent on the particular device receiving it, the exact result not being defined by the IEEE-488 (1978) standard.



When received by the 2300 it will respond with a handshake and will not cause an error but will be ignored.

The user should note that only the addressed form of this command is defined by the IEEE 488 (1978) standard; however, certain manufacturers also include an unaddressed form of this command. The result of receiving this "unofficial" command by the 2300 is not defined and may cause bus errors if used.

This command is implemented in HP Basic by the statement **TRIGGER 715** for the address form, and **TRIGGER 7** for the unaddressed, "unofficial" form.

#### 7-4-4. Go to Local (GTL)

This addressed command will cause the individual addressed device to enter the LOCAL state (i.e. enables manual operation of the device). This command is fully implemented in the 2300 and is commanded in HP Basic by the statement **LOCAL 715**.

The user should note that many computers also have a similar unaddressed version of this command (**LOCAL 7** for HP Basic). This command is actually quite different from the addressed command (it unasserts the REN line) but will cause all of the devices, including the 2300, to enter the LOCAL state.

#### 7-4-5. Interface Clear (IFC)

This command will cause all of the interfaces of the devices to enter an idle state. This is fully implemented in the 2300 and may be commanded in HP Basic by the statement **RESET 7**.

#### 7-4-6. Identify (IDY)

This command is also called "parallel poll". This will cause all devices to respond by simultaneously placing their

parallel poll response byte onto the DIO bus wires. The 2300 does not implement this command.

#### 7-4-7. Local Lock Out (LLO)

This command will cause all of the devices to enter either the *local with lockout* or *remote with lockout* state (depending on whether they were in LOCAL or REMOTE states respectively). The function of this command is to disable the manually operated LOCAL key or control on the devices. This command is not implemented in the 2300 and is ignored if received.

#### 7-4-8. Parallel Poll Configure (PPC), Enable (PPE), Disable (PPD), and Unconfigure (PPU)

These command are used to set the Parallel Poll response byte and to disable the parallel poll response. These commands are not implemented in the 2300 and are ignored if received.

#### 7-4-9. Remote Enable (REN)

This command (the assertion of the REN wire) enables all devices to enter the REMOTE state when they next receive their listen address. The 2300 fully implements this function which may be commanded in HP Basic by the statement **REMOTE 7**.

Many computers also have a command which includes the sending of the listen address which will place only the addressed device into the REMOTE state. In HP Basic this is accomplished by the statement **REMOTE 715**, which would place only the device at address 15 into remote.



#### 7-4-10. Serial Poll Enable (SPE) and Disable (SPD)

These commands control the process of performing a serial poll. The serial poll sequence is as follows:

- 1) The controller commands SPE.
- 2) The controller addresses a single device as a talker.
- 3) The addressed device returns its Serial Poll response byte.
- 4) The controller reads the response byte.
- 5) The controller may now repeat the sequence from step 2 or send SPD to end the serial poll.

The 2300 fully implements this function and may be commanded to send its serial poll response byte in HP Basic by the statement **SPOLL(715)**. This statement will implement the entire sequence once. The 2300 returns a null (0) response byte when polled if no errors are present, or if SRQ's are not enabled (see 7-7-7).

#### 7-4-11. Take Control (TCT)

This command from the controller to another potential controller will request the other to take over as controller. The 2300 does not have the capability of becoming a controller thus this command is not implemented and will be ignored.

#### 7-5. Setting the IEEE Address

The IEEE *listen address* tells the system controller where to find a device when it wishes to communicate with it. The address of the 2300 is determined by the configuration of a 5-pole DIP switch on the rear of the instrument. The address may be any number from 1 to 30. This number is calculated using a binary-weighted code set by the switches shown

in Figure 7-1. For example, address "15" would be set by placing the switches in the following configuration:

1 = on, 2 = on, 4 = on, 8 = on, and 16 = off

because  $1 + 2 + 4 + 8 = 15$ .

The address you choose is entirely dependent on your application and by the type and quantity of devices on your IEEE bus. Some guidelines to follow are:

- 1) Each device on the bus must have its own unique address. Operating two devices at the same address will produce undefined results and is not recommended.
- 2) Avoid setting the 2300 to address 0 (all switches off) or to address 31 (all switches on) as this may interfere with the system controller.
- 3) Should the address be changed, instrument power must be reset in order to establish the new address.

#### 7-6. Device Dependent Commands

The device dependent command set for the 2300 is described in the following paragraphs. Examples are given for each command. As in the previous paragraphs it is assumed that the 2300 has an address of 15 and that HP Basic is the programming language. If you are using a language other than HP Basic, consult your programmer's manual for the correct command syntax.

#### 7-6-1. REMOTE and LOCAL States

Although not truly "device dependent" commands, a full explanation of the implementation of the LOCAL and REMOTE states is explained here.



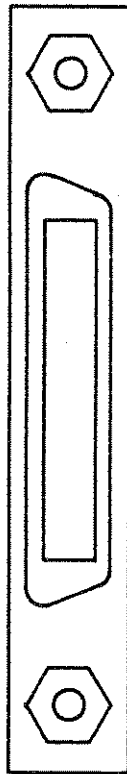
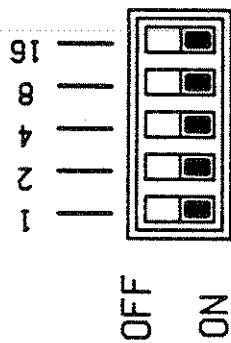


FIGURE 7 - 1 IEEE ADDRESS SWITCH



## LOCAL

When the 2300 is in the LOCAL state the REMOTE indicator on the front panel is extinguished and full manual control of the 2300 as described in Sections 4 through 6 may be performed. The user should note that it is not possible to enter the REMOTE state other than via the system controller. The user should also note that the 2300 will accept commands from the IEEE-488 bus while in the LOCAL state but they will be discarded.

## REMOTE

As mentioned previously, if the 2300 receives its listen address while the REN line is asserted it will enter the REMOTE state. In this state the REMOTE indicator on the front panel is illuminated and all keys on the front panel are disabled with the exception of the RUN/HOLD and SAMPLE keys.

### 7-6-2. Post RESET delay

To ensure that all wires are settled following a device clear it is recommended that a minimum delay of 500ms is allowed prior to performing any bus operation with the 2300 following either of the above actions.

## 7-7. Commands and Examples Using HP Basic

This set of paragraphs lists all commands recognized by the 2300 Series of Power Analyzers. As in preceding examples it is assumed that the programmer is using HP Basic and that the 2300 has its listen address set to 15. It is also assumed that the user is familiar with the operating principles discussed in Sections 4 through 6. If you are using a language other than HP Basic, consult your programmer's manual for the correct command syntax.

**Notes:** The 2300 will look for an "input data terminator" that signals the end of the command line. The 2300 recognizes a (carriage return, line-feed) as the end of the command line. These items should be automatically sent by the system controller and are not shown in the examples that follow. Note that all commands *must* be sent in upper case.

### 7-7-1. REMOTE and LOCAL

These commands place the 2300 in the REMOTE or LOCAL operating modes:

REMOTE 715 Enables remote operation  
LOCAL 715 Selects local operation

### 7-7-2. Voltage Range Commands

These commands are used to select the voltage range of the 2300 (2300L):

Examples:

OUTPUT 715;"V0" Selects 50 (5) volt range  
OUTPUT 715;"V1" Selects 150 (15) volt range  
OUTPUT 715;"V2" Selects 300 (30) volt range  
OUTPUT 715;"V3" Selects 600 (60) volt range

### 7-7-3. Current Range Commands

These commands are used to select the current range of the 2300:

Examples:

OUTPUT 715;"I0" Selects 0.2 amp range  
OUTPUT 715;"I1" Selects 0.5 amp range  
OUTPUT 715;"I2" Selects 1 amp range  
OUTPUT 715;"I3" Selects 2 amp range  
OUTPUT 715;"I4" Selects 5 amp range  
OUTPUT 715;"I5" Selects 10 amp range  
OUTPUT 715;"I6" Selects 20 amp range  
OUTPUT 715;"I7" Selects 50 amp range  
OUTPUT 715;"I8" Selects 100 amp range



#### 7-7-4. Channel Selection Commands

These commands are used to select which channel's data ( $\phi A$ ,  $\phi B$ , or  $\phi C$ ) is displayed on the 2300 and available via the bus.

Examples:

OUTPUT 715;"W0" Selects  $\phi A$   
OUTPUT 715;"W1" Selects  $\phi B$   
OUTPUT 715;"W2" Selects  $\phi C$   
OUTPUT 715;"W3" Selects 3 $\phi$ , 3-wire mode  
OUTPUT 715;"W4" Selects 3 $\phi$ , 4-wire mode

#### 7-7-5. Output Data Selection Queries

These queries select which measurement data will be made available to the controller on the next read. Once selected, that data is returned on all subsequent reads of the controller.

Examples:

OUTPUT 715;"T0" Selects Voltage Data  
OUTPUT 715;"T1" Selects Current Data  
OUTPUT 715;"T2" Selects Power Data  
OUTPUT 715;"T3" Selects Average Power Data  
OUTPUT 715;"T4" Selects Watt-Hour Data

**Notes:** The output data is invalid for the T0 and T1 queries if the W3 or W4 command has been selected. Also, refer to section 7-7-9 for more details on the T3 and T4 queries.

#### 7-7-6. Output Data Terminators

These codes determine the "output data terminator" that will be attached to the end of the data returned by the 2300:

Examples:

OUTPUT 715;"D0"  $\text{C}_R$  and  $\text{L}_F$  (default)  
OUTPUT 715;"D1"  $\text{C}_R$  and  $\text{L}_F$  with EOI  
OUTPUT 715;"D2"  $\text{C}_R$   
OUTPUT 715;"D3"  $\text{C}_R$  with EOI  
OUTPUT 715;"D4" EOI  
OUTPUT 715;"D5"  $\text{L}_F$

#### 7-7-7. SRQ and Serial Poll Commands

The 2300 may assert the SRQ wire if it receives an undecipherable command. This function is enabled or disabled by the commands below.

Examples:

OUTPUT 715;"Q0" Disables the 2300 SRQ  
OUTPUT 715;"Q1" Enables the 2300 SRQ

When the system controller conducts a serial poll, the 2300 responds with a non-zero byte of data informing the controller of the reason for the SRQ. If the 2300 did not generate the SRQ, a zero byte is used as the response.

#### 7-7-8. Programming Status Query

This query causes the 2300 to return its "configuration status word" instead of the selected measurement data the next time it is read by the controller. This status word contains data regarding the current settings of certain parameters such as range information and data terminators.

After receiving the query "E", the 2300 makes the status word available. No other data is available until this word is read. The configuration status word is in the format:

$$Q_n V_n I_n W_n D_n T_n$$

where the letters correspond to the commands described previously, and "n" refers to the current number relating to that command.

For example,

$$Q0V2I1W2D0T0$$

would indicate that the 2300 is in the 300V and 0.5A ranges, with the volts data for  $\phi C$  available



over the bus; no SRQ's and a  $\overline{CRF}$  at the end of the transmitted data.

Option LF: Multiply watt-hours by 2  
Option HS-5: Divide watt-hours by 2  
Option HS-12: Divide watt-hours by 5

### 7-7-9. Average Power and Watt-Hour Commands

These commands are used to control the compiling of average power and watt-hours. The "S" command starts compiling while the "F" command stops compilation and calculates average power or watt-hours accumulated since the receipt of "S". The calculation of either average power or watt-hours is determined by the "T" command (7-7-5) current at the time "F" was received. "F" commands received before "S" commands are ignored.

Sample Program #1 (Average Watts):

```
10 OUTPUT 715;"S"   start compiling data
20 OUTPUT 715;"T3"  use the data for avg pwr
30 OUTPUT 715;"F"   stop compiling & calculate
40 WAIT .5          recommended delay 500ms
50 ENTER 715;A$     display the result
```

(A\$ will contain the average power data)

Sample Program #2 (Watt-Hours):

```
10 OUTPUT 715;"S"   start compiling data
20 OUTPUT 715;"T4"  use the data for watt-hours
30 OUTPUT 715;"F"   stop compiling & calculate
40 WAIT .5          recommended delay 500ms
50 ENTER 715;A$     display the result
```

(A\$ will contain the watt-hour data)

Voltage, current and instantaneous power data may be read while compiling power data. Reading average power or watt-hour data before the receipt of "F" will produce undefined results. Changing the "W" command following the "S" command will also produce undefined results.

Note: The following manipulations of the output result are required when using these options:

### 7-7-10. Reading the Displays

Upon receipt of one of the five "T" queries (see 7-7-5), the 2300 places either the volts, amps or watts displayed data in its output buffer. This data may be now be read by the system controller. The data is of the following format:

$$\pm 1.9999E_n O \{D?\}$$

Where:

$\pm 1.9999$  are the significant digits of the measurement.  
En is the exponent (power of 10) to be applied to the significant digits i.e.  $\pm 1.9999 \times 10^n$   
O indicates an overrange condition on any channel.  
{D?} is the output data terminator sent to signify the end of the data. This is usually a  $\overline{CRF}$ , but may be changed using the "D" command (see 7-7-6).

The data is returned in scientific notation with the units of watts, volts or amps depending on which "T" query was sent. If no "T" query was sent, the 2300 returns its default data which is the voltage measurement.

The 2300 may be read at any time; however, caution must be taken to avoid erroneous data. A delay of 500ms should be allowed following a "Tn" query before reading data. A delay of 5 seconds should be allowed for maximum accuracy following a range change (In or Vn), or channel change (Wn).

The following are sample programs (in Hewlett Packard Basic) that may be used to read the 2300's output buffer. Assume that the 2300 has inputs applied to it such that VOLTS = "125.72", AMPS = "79.52" and POWER =





"9997", and that the instrument is displaying  $\phi B$  data.

Sample Program #3 (Current Query):

```
10 OUTPUT 715;"W1" requests  $\phi B$  data
20 OUTPUT 715;"T1" requests current data
30 ENTER 715;A$ controller reads buffer
40 PRINT A$ display the data
```

The result is .7952E2, which is equal to  $.7952 \times 10^2$  or 79.52 amps.

Sample Program #4 (Status-Word Query):

```
10 OUTPUT 715;"E" requests status word
20 ENTER 715;A$ controller reads buffer
30 PRINT A$ display the data
```

The result is Q0V1I8W1D0T1 which was explained in Section 7-7-8.

## 7-8. IEEE-488 Device-Dependent Command Set Summary for 2300/01

Listed below is a summary of the device-dependent command set for the 2300 Series of Power Analyzers. Refer to the preceding paragraphs for greater details on use of the various commands. The settings labeled "default" are the conditions that exist whenever the 2300 is initially powered up. The default conditions are also restored upon returning the 2300 to Local mode. The commands are listed in alphabetical order.

### Command      Result

**Dn**              **Output data terminator command**  
D0              Carriage return and line feed (default)  
D1              Carriage return and line feed with EOI  
D2              Carriage return only  
D3              Carriage return with EOI  
D4              EOI only  
D5              Line feed only

**E**                **Programming status query**  
2300 responds with a configuration status word the next time it is read.

**F**                **Finish compiling command**  
Stops compilation of average watts or watt-hour data.

**In**               **Current range commands**  
I0               0.2 amp range (default)  
I1               0.5 amp range  
I2               1 amp range  
I3               2 amp range  
I4               5 amp range  
I5               10 amp range  
I6               20 amp range  
I7               50 amp range  
I8               100 amp range



**Qn**      **SRQ enable command**  
Q0      Disable SRQ (default)  
Q1      Assert SRQ for invalid input data

**S**      **Start compiling command**  
Starts compilation of average watts or watt-hour data.

**Tn**      **Output data selection query** (Selects data output to the controller on the next read)  
T0      Requests voltage data (default)  
T1      Requests current data  
T2      Requests power data  
T3      Requests average power data  
T4      Requests watt-hour data

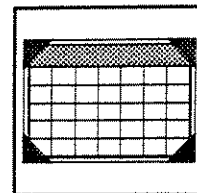
**Vn**      **Voltage range commands**  
V0      50 volt range (5V 2300L) (default)  
V1      150 volt range (15V 2300L)  
V2      300 volt range (30V 2300L)  
V3      600 volt range (60V 2300L)

**Wn**      **Display selection commands** (Selects which channel's data is displayed and output)  
W0       $\phi$ A data (default)  
W1       $\phi$ B data  
W2       $\phi$ C data  
W3      3 $\phi$  3-wire data  
W4      3 $\phi$  4-wire data



## SECTION VIII CALIBRATION PROCEDURE

---



### 8-1. General

This section provides calibration procedures for the 2300 Series Digital Power Analyzers. Two calibration procedures are included. First, the Routine Calibration of Section 8-4 should be performed at regular intervals (annually is recommended) to ensure that full instrument accuracy is maintained. The other, referred to as Post-Maintenance Calibration, need be performed only after repair or component replacement.

### 8-2. Procedure Notes

Calibration should be performed with the top and bottom covers installed except when making adjustments requiring their removal. It is recommended that the unit be allowed two hours for warm-up prior to calibration to achieve temperature stabilization. Maximum thermal stability may be achieved through the use of a calibration cover (Valhalla Stock #04-10749). This item allows adjustments to be made without having to repeatedly raise and lower the top cover.

A shorthand notation is used in the two procedures to identify the location of the calibration adjustments. The adjustments on the signal processing boards are identified  $\phi A$ ,  $\phi B$ , and  $\phi C$ . For example, the calibration step using R3 on the phase A signal processing board is noted as  $\phi AR3$ . The main board is identified in a similar manner e.g. MBR3.

The locations of the adjustments are shown on drawings 2300-600 for the signal processing board and 2300-601 for the main board.

### 8-3. Required Test Equipment

The following test equipment is required for calibration of the 2300 Series of Digital Power Analyzers:

- 1) AC Voltage Calibrator: 1V to 600V,  $\pm 0.03\%$  Accuracy (Valhalla 2703 or equivalent).
- 2) AC Voltage & Phase Calibrator: 0 to 2V,  $\pm 0.03\%$  Accuracy (Valhalla 2705 or equivalent).
- 3) AC Transconductance Amplifier: 0.1A to 100A,  $\pm 0.25\%$  Accuracy (Valhalla 2555A or equivalent).
- 4) DC Voltmeter with DC Accuracy of  $\pm 0.3\%$  or greater.

### 8-4. Routine Calibration

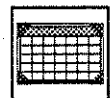
This procedure should be performed at regular intervals to ensure specified instrument accuracy. The procedure must be performed in its entirety and in the order given. Skipping steps or performing them out of order may cause the entire instrument to be out of calibration. Calibration adjustments are accessed by removing the 5 screws in the rectangular top cover of the instrument. This cover should be kept in place except during adjustment to achieve maximum thermal stability.

When calibrating the 2300L or 2301L, reduce all of the voltage inputs to one-tenth the value given. In all steps, the voltage and current calibrator frequencies should be set to 100Hz.

### 8-4-1. Voltage Calibration

☛ When calibrating Models 2301 and 2301L, only steps 1 through 12 need be performed.

- 1) Connect the DVM low lead to a phase A shield screw, high lead to  $\phi$ AIC7 pin 6. Adjust  $\phi$ AR3 for 0 volts  $\pm$  1mV DC. Disconnect the DVM.
- 2) Connect the AC Voltage calibrator as shown in Figure 8-1.
- 3) Select  $\phi$ A and the 600 (60) volt range.
- 4) Apply 600.0 volts and adjust MBR20 for a display of 600.0.
- 5) Apply 60.00 volts and adjust MBR119 for a display of 60.0.
- 6) Repeat steps 4 and 5 for minimum interaction.
- 7) Select the 300 (30) volt range.
- 8) Apply 300.0 volts and adjust MBR24 for a display of 300.0.
- 9) Select the 150 (15) volt range.
- 10) Apply 150.00 volts and adjust MBR18 for a display of 150.00.
- 11) Select the 50 (5) volt range.
- 12) Apply 50.00 volts and adjust MBR22 for a display of 50.00. Disconnect the voltage calibrator.
- 13) Connect the DVM low lead to the phase B shield, high lead to  $\phi$ BIC7 pin 6. Adjust  $\phi$ BR3 for 0v  $\pm$  1mV DC. Disconnect the DVM.
- 14) Connect the AC Voltage Calibrator as shown in Figure 8-2.
- 15) Select  $\phi$ B and the 600 (60) volt range.
- 16) Apply 600.0 volts and adjust  $\phi$ BR22 for a display of 600.0.
- 17) Apply 60.00 volts and adjust MBR219 for a display of 60.00.
- 18) Repeat steps 16 and 17 for minimum interaction.
- 19) Select the 300 (30) volt range.
- 20) Apply 300.0 volts and adjust  $\phi$ BR25 for a display of 300.0.
- 21) Select the 150 (15) volt range.
- 22) Apply 150.00 volts and adjust  $\phi$ BR27 for a display of 150.00.
- 23) Select the 50 (5) volt range.
- 24) Apply 50.00 volts and adjust  $\phi$ BR29 for a display of 50.00. Disconnect the voltage calibrator.
- 25) Connect the DVM low lead to the phase C shield, high lead to  $\phi$ CIC7 pin 6. Adjust  $\phi$ CR3 for 0v  $\pm$  1mV DC. Disconnect the DVM.
- 26) Connect the AC voltage calibrator as shown in Figure 8-3.
- 27) Select  $\phi$ C and the 600 (60) volt range.
- 28) Apply 600.00 volts and adjust  $\phi$ CR22 for a display of 600.0.
- 29) Apply 60.00 volts and adjust MBR319 for a display of 60.00.
- 30) Repeat steps 28 and 29 for minimum interaction.
- 31) Select the 300 (30) volt range.
- 32) Apply 300.0 volts and adjust  $\phi$ CR25 for a display of 300.0.
- 33) Select the 150 (15) volt range.
- 34) Apply 150.00 volts and adjust  $\phi$ CR27 for a display of 150.00.
- 35) Select the 50 (5) volt range.
- 36) Apply 50.00 volts and adjust  $\phi$ CR29 for a display of 50.00. Disconnect the voltage calibrator.



## 8-4-2. Current Calibration

☛ When calibrating Models 2301 and 2301L, only steps 1 through 16 need be performed.

- 1) Connect the DVM low lead to a phase A shield screw, high lead to  $\phi$ AIC5 pin 6. Adjust  $\phi$ AR9 for  $0V \pm 10mV$  DC. Disconnect the DVM.
- 2) Connect the 2300 as shown in Figure 8-4 using the 1 amp shunt.
- 3) Select  $\phi$ A and the 1 amp range.
- 4) Apply 1.0000 amp and adjust MBR11 for a display of 1.0000.
- 5) Apply 0.1000 amp and adjust MBR128 for a display of 0.1000.
- 6) Repeat steps 4 and 5 for minimum interaction.
- 7) Select the 0.5 amp range.
- 8) Apply 0.5000 amps and adjust MBR13 for a display of 0.5000.
- 9) Select the 0.2 amp range.
- 10) Apply 0.2000 amps and adjust MBR15 for a display of 0.2000.
- 11) Connect the 2300 as shown in Figure 8-4 using the 10 amp shunt.
- 12) Select the 5 amp range.
- 13) Apply 5.000 amps  $\phi$ AR5 for a display of 5.000.
- 14) Connect the 2300 as shown in Figure 8-4 using the 100 amp shunt.
- 15) Select the 50 amp range.
- 16) Apply 50.00 amps and adjust  $\phi$ AR7 for a display of 50.00. Disconnect the current calibrator.
- 17) Connect the DVM low lead to a  $\phi$ B shield screw, high lead to  $\phi$ BIC5 pin 6. Adjust  $\phi$ BR9 for  $0V \pm 10mV$  DC. Remove the DVM.
- 18) Connect the 2300 as shown in Figure 8-5 using the 1 amp shunt.
- 19) Select  $\phi$ B and the 1 amp range.
- 20) Apply 1.0000 amp and adjust  $\phi$ BR16 for a display of 1.0000.
- 21) Apply 0.1000 amp and adjust MBR228 for a display of 0.1000.
- 22) Repeat steps 20 and 21 for minimum interaction.
- 23) Select the 0.5 amp range.
- 24) Apply 0.5000 amps and adjust  $\phi$ BR15 for a display of 0.5000.
- 25) Select the 0.2 amp range.
- 26) Apply 0.2000 amps and adjust  $\phi$ BR12 for a display of 0.2000.
- 27) Connect the 2300 as shown in Figure 8-5 using the 10 amp shunt.
- 28) Select the 5 amp range.
- 29) Apply 5.000 amps and adjust  $\phi$ BR5 for a display of 5.000.
- 30) Connect the 2300 as shown in Figure 8-5 using the 100 amp shunt.
- 31) Select 50 amp range.
- 32) Apply 50.00 amps and adjust  $\phi$ BR7 for a display of 50.00. Disconnect the current calibrator.
- 33) Connect the DVM low lead to a  $\phi$ C shield screw, high lead to  $\phi$ CIC5 pin 6. Adjust  $\phi$ CR9 for  $0V \pm 10mV$  DC. Remove the DVM.
- 34) Connect the 2300 as shown in Figure 8-6 using the 1 amp shunt.
- 35) Select  $\phi$ C and the 1 amp range.
- 36) Apply 1 amp and adjust  $\phi$ CR16 for a display of 1.0000.
- 37) Apply 0.1000 amp and adjust MBR328 for a display of 0.1000.




- 38) Repeat steps 37 and 38 for minimum interaction.
- 39) Select the 0.5 amp range.
- 40) Apply 0.5000 amps and adjust  $\phi$ CR15 for a display of 0.5000.
- 41) Select the 0.2 amp range.
- 42) Apply 0.2000 amps and adjust  $\phi$ CR12 for a display of 0.2000.
- 43) Connect the 2300 as shown in Figure 8-6 using the 10 amp shunt.
- 44) Select the 5 amp range.
- 45) Apply 5.000 amps and adjust  $\phi$ CR5 for a display of 5.000.
- 46) Connect the 2300 as shown in Figure 8-6 using the 100 amp shunt.
- 47) Select the 50 amp range.
- 48) Apply 50.00 amps and adjust  $\phi$ CR7 for a display of 50.00. Disconnect the current calibrator.

### 8-4-3. Power Calibration

☛ When calibrating Models 2301 and 2301L, only steps 1 through 20 need be performed.

- 1) Connect the 2300 as shown in Figure 8-7.
- 2) Select  $\phi$ A, the 1 amp and the 150 (15) volt ranges.
- 3) Apply 150.00 volts and 1.0000 amps and adjust MBR27 for a display of 150.00.
- 4) Apply 15.00 volts and 1.0000 amps and adjust MBR110 for a display of 15.00.
- 5) Repeat steps 3 and 4 for minimum interaction.
- 6) Select the 50 (5) volt range.
- 7) Apply 50.00 volts and 1.0000 amps and adjust MBR37 for a display of 50.00.

- 8) Select the 300 (30) volt range.
- 9) Apply 300.0 volts and 1.0000 amps and adjust MBR39 for a display of 300.0.
- 10) Select the 600 (60) volt range.
- 11) Apply 600.0 volts and 1.0000 amps and adjust MBR35 for a display of 600.0.
- 12) Select the 0.5 amp and 50 (5) volt ranges.
- 13) Apply 50.00 volts and 0.5000 amps and adjust MBR41 for a display of 25.00.
- 14) Select the 150 (15) volt range.
- 15) Apply 150.00 volts and 0.5000 amps and adjust MBR33 for a display of 75.00.
- 16) Select the 0.2 amp and 50 (5) volt ranges.
- 17) Apply 0.2000 amps and 50.00 volts and adjust MBR31 for a display of 10.000.
- 18) Select the 600 (60) volt range.
- 19) Apply 600.0 volts and 0.2000 amps and adjust MBR29 for a display of 120.00.
- 20) Connect the 2300 as shown in Figure 8-8.
- 21) Select  $\phi$ B, the 1 amp and the 150 (15) volt ranges.
- 22) Apply 150.00 volts and 1.0000 amps and adjust  $\phi$ BR40 for a display of 150.00.
- 23) Apply 15.00 volts and 1.0000 amps and adjust MBR210 for a display of 15.00.
- 24) Repeat steps 22 and 23 for minimum interaction.
- 25) Connect the 2300 as shown in Figure 8-9.
- 26) Select  $\phi$ C, the 1 amp and the 150 (15) volt ranges. 

- 27) Apply 150.00 volts and 1.0000 amps and adjust  $\phi$ CR40 for a display of 150.00.
- 28) Apply 15.00 volts and 1.0000 amps and adjust MBR310 for a display of 150.00.
- 29) Repeat steps 27 and 29 for minimum interaction.

### 8-5. Post-Maintenance Calibration

The Post-Maintenance Calibration is a rough adjustment procedure that should be performed following repair or component replacement to bring the 2300 within range of the Routine Calibration adjustments. This procedure need be performed only following instrument repair, and need not be performed on a regular basis. This procedure should be followed by full calibration using the procedure of Section 8-4. In all steps the voltage and current calibrators should be set to 100Hz.

#### 8-5-1. A-to-D Reference Calibration

Do *not* adjust DBR9, DBR34, or DBR48 on the display board at any time!! These are factory only calibrations and never need adjustment. If any A-to-D converter is repaired consult the factory for the adjustment procedure.

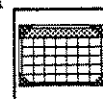
#### 8-5-2. Voltage Calibration

- 1) Connect the DVM low lead to a phase A shield screw, high lead to  $\phi$ AIC7 pin 6.
- 2) Adjust  $\phi$ AR3 for  $0V \pm 1mVDC$ .
- 3) Connect the 2300 as shown in Figure 8-1. Move the DVM high lead to the left side of R37.
- 4) Select  $\phi$ A and the 600 (60) volt range.

- 5) Apply 600.0 volts and adjust  $\phi$ AR22 for 5.000 VDC on the DVM.
- 6) Select the 300 (30) volt range.
- 7) Apply 300.0 volts and adjust  $\phi$ AR25 for 5.000 VDC on the DVM.
- 8) Select the 150 (15) volt range.
- 9) Apply 150.00 volts and adjust  $\phi$ AR27 for 5.000 VDC on the DVM.
- 10) Select the 50 (5) volt range.
- 11) Apply 50.00 volts and adjust  $\phi$ AR29 for 5.000 VDC on DVM.
- 12) Disconnect the DVM and AC voltage calibrator.

#### 8-5-3. Current Calibration

- 1) Connect the DVM low lead to a phase A shield screw and the high lead to  $\phi$ AIC5 pin 6.
- 2) Adjust  $\phi$ AR9 for  $0V \pm 10mV DC$ .
- 3) Connect the 2300 as shown in Figure 8-4 using the 1 amp shunt. Move the DVM high lead to the left side of R38.
- 4) Select  $\phi$ A and the 1 amp range.
- 5) Apply 1.0000 amps and adjust  $\phi$ AR16 for 5.000 VDC on the DVM.
- 6) Select the 0.5 amp range.
- 7) Apply 0.5000 amps and adjust  $\phi$ AR15 for 5.000 VDC on the DVM.
- 8) Select the 0.2 amp range.
- 9) Apply 0.2000 amps and adjust  $\phi$ AR12 for 5.000 VDC on the DVM.
- 10) Connect the 2300 as shown in Figure 8-4 using the 10 amp shunt.
- 11) Select the 10 amp range.
- 12) Apply 10.000 amps and adjust  $\phi$ AR5 for 5.000 VDC on the DVM.



- 13) Connect the 2300 as shown in Figure 8-4 using the 100 amp shunt.
- 14) Select the 100 amp range.
- 15) Apply 100.00 amps and adjust  $\phi$ AR7 for 5.000 VDC on the DVM.
- 16) Disconnect the DVM and current calibrator.

#### 8-5-4. Power Calibration

- 1) Connect the 2300 as shown in Figure 8-7.
- 2) Select  $\phi$ A and the 150 (15) volt and 1 amp ranges.
- 3) Connect the DVM low lead to the negative leg of MBC5 and the high lead to the front leg of MBR9.
- 4) Apply 150.00 volts and 1.0000 amps and adjust  $\phi$ AR40 for 2.500 VDC.
- 5) Disconnect the DVM and calibrators.

#### 8-6. Option IOX Calibration

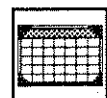
Option IOX should be calibrated following successful completion of the Routine Calibration procedure of Section 8-4. In this procedure, all measurements are made at the IOX connector using a DC voltmeter. All measurements are made with DVM high lead. The DVM low lead should be connected to the IOX connector common at pin 12.

Adjustments are accessed by removing the bottom cover of the instrument. **Caution!** AC line power is exposed at this point. Take precautions to avoid contact with AC power wiring.

**Note:** In simultaneous TL-4/IOX installations, adjustments are accessed from the top of the instrument and removal of the bottom cover is not necessary.

#### 8-6-1. Channel A IOX Calibration

- 1) Connect the 2300 as shown in Figure 8-7. Select  $\phi$ A, 150 (15) volts, 1 amp ranges.
- 2) Apply 150.00 volts and adjust RV12 for an output of 5.000 volts at pin 1 of the IOX connector.
- 3) Apply 15.00 volts and adjust RV1 for an output of .5000 volts at pin 1 of the IOX connector.
- 4) Repeat steps 2 and 3 for minimum interaction.
- 5) Apply 1.0000 amps and adjust RV13 for an output of 5.000 volts at pin 2 of the IOX connector.
- 6) Apply .1000 amps and adjust RV2 for an output of .5000 volts at pin 2 of the IOX connector.
- 7) Repeat steps 5 and 6 for minimum interaction.
- 8) Apply 150.00 volts and 1.0000 amps; adjust RV14 for 5.000 volts at pin 3 of the IOX connector.
- 9) Apply 15.00 volts and 1.0000 amps and adjust RV7 for .5000 volts at pin 3 of the IOX connector.
- 10) Repeat steps 8 and 9 for minimum interaction.
- 11) Apply 150.00 volts and 1.0000 amps; adjust RV15 for 2.500 volts at pin 10 of the IOX connector.
- 12) Apply 15.00 volts and 1.0000 amps and adjust RV10 for .2500 volts at pin 10 of the IOX connector.
- 13) Repeat steps 11 and 12 for minimum interaction.
- 14) Apply 150.00 volts and 1.0000 amps and adjust RV16 for 1.666 volts at pin 11 of the IOX connector.
- 15) Apply 15.00 volts and 1.0000 amps and adjust RV11 for .1666 volts at pin 11 of the IOX connector.
- 16) Repeat steps 14 and 15 for minimum interaction.





### 8-6-2. Channel B IOX Calibration

- 1) Connect the 2300 as shown in Figure 8-8. Select  $\phi B$ , 150 (15) volts, and 1 amp ranges.
- 2) Apply 150.00 volts and adjust RV17 for 5.000 volts at pin 4 of the IOX connector.
- 3) Apply 15.00 volts and adjust RV3 for .5000 volts at pin 4 of the IOX connector.
- 4) Repeat steps 2 and 3 for minimal interaction.
- 5) Apply 1.0000 amps and adjust RV18 for 5.000 volts at pin 5 of the IOX connector.
- 6) Apply .1000 amps and adjust RV4 for .5000 volts at pin 5 of the IOX connector.
- 7) Repeat steps 5 and 6 for minimal interaction.
- 8) Apply 150.00 volts and 1.0000 amps and adjust RV19 for 5.000 volts at pin 6 of the IOX connector.
- 9) Apply 15.00 volts and 1.0000 amps and adjust RV8 for .5000 volts at pin 6 of the IOX connector.
- 10) Repeat steps 8 and 9 for minimal interaction.
- 11) Apply 150.00 volts and 1.0000 amps and adjust RV20 for 1.666 volts at pin 11 of the IOX connector.

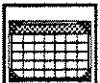
### 8-6-3. Channel C IOX Calibration

- 1) Connect the 2300 as shown in Figure 8-9. Select  $\phi C$ , 150 (15) volt and 1 amp ranges.
- 2) Apply 150.00 volts and adjust RV21 for 5.000 volts at pin 7 of the IOX connector.
- 3) Apply 15.00 volts and adjust RV5 for .5000 volts at pin 7 of the IOX connector.

- 4) Repeat steps 2 and 3 for minimal interaction.
- 5) Apply 1.000 amps and adjust RV22 for 5.000 volts at pin 8 of the IOX connector.
- 6) Apply .1000 amps and adjust RV6 for .5000 volts at pin 8 of the IOX connector.
- 7) Repeat steps 5 and 6 for minimal interaction.
- 8) Apply 150.00 volts and 1.0000 amps; adjust RV23 for 5.000 volts at pin 9 of the IOX connector.
- 9) Apply 15.00 volts and 1.0000 amps and adjust RV9 for .5000 volts at pin 9 of the IOX connector.
- 10) Repeat steps 8 and 9 for minimal interaction.
- 11) Apply 150.00 volts and 1.0000 amps and adjust RV24 for 2.500 volts at pin 10 of the IOX connector.
- 12) Apply 150.00 volts and 1.0000 amps and adjust RV25 for 1.666 volts at pin 11 of the IOX connector.

### 8-7. Option IO-3 Calibration

Option IO-3 calibration should be performed only after the 2301 has been completely calibrated. The IO-3 may be calibrated in any volts and any current range desired, provided that the user provides full scale voltage and current for those ranges (i.e. 600V on the 600V range). In the following procedure the 150V/1A ranges and inputs are used.

Connect the inputs as shown in Figure 8-7 and select the 150V and 1A ranges. A DVM with at least .03% DC accuracy is used to monitor the outputs of Option IO-3. The pin functions for the IO-3 connector are shown in Figure 3-2 at the front of this manual. The adjustments are accessed by 

removing the bottom cover of the instrument. **Caution!** AC line power is exposed at this point. The IO-3 adjustment potentiometers are located on a small PC board near the AC receptacle.

#### 8-7-1. IO-3 Volts Calibration

Connect the DVM negative lead to pin 3 of the IO-3 connector on the rear panel. Connect the DVM positive lead to pin 6. Apply 15.00 volts (1/10 of full scale) to the 2301. Adjust RV2 "Volts Zero" on the IO-3 board for .5000 volts on the DVM. Apply 150.00 volts (full scale) to the 2301 and adjust RV1 "Volts Scaling" for 5.000 volts on the DVM. Repeat as necessary for minimum interaction.

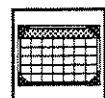
#### 8-7-2. IO-3 Amps Calibration

Connect the DVM negative lead to pin 2 of the IO-3 connector. Connect the DVM positive lead to pin 1. Apply .1000 amps (1/10 of full scale) to the 2301. Adjust RV4 "Amps Zero" for .5000 volts on the DVM. Apply 1.0000 amp (full scale) to the 2301. Adjust RV3 "Amps Scaling" for 5.000 volts on the DVM. Repeat as necessary for minimum interaction.

#### 8-7-3. IO-3 Watts Calibration

Connect the DVM negative lead to pin 4 of the IO-3 connector. Connect the DVM positive lead to pin 5. Apply 15.00 volts and 1.0000 amp (1/10 of full scale watts) to the 2301. Adjust RV6 "Watts Zero" for .5000 volts on the DVM. Apply 150.00 volts and 1.0000 amp (fullscale watts) to the 2301. Adjust RV5 "Watts Scaling" for 5.000 volts on the DVM. Repeat as necessary for minimum interaction.

☛ If IO-3 is installed in a Model 2300 as opposed to a 2301, RV6 should be used to adjust the "Watts Zero" output for .2500V, not .5000V. The adjustment of RV6 is eliminated in the 2300.



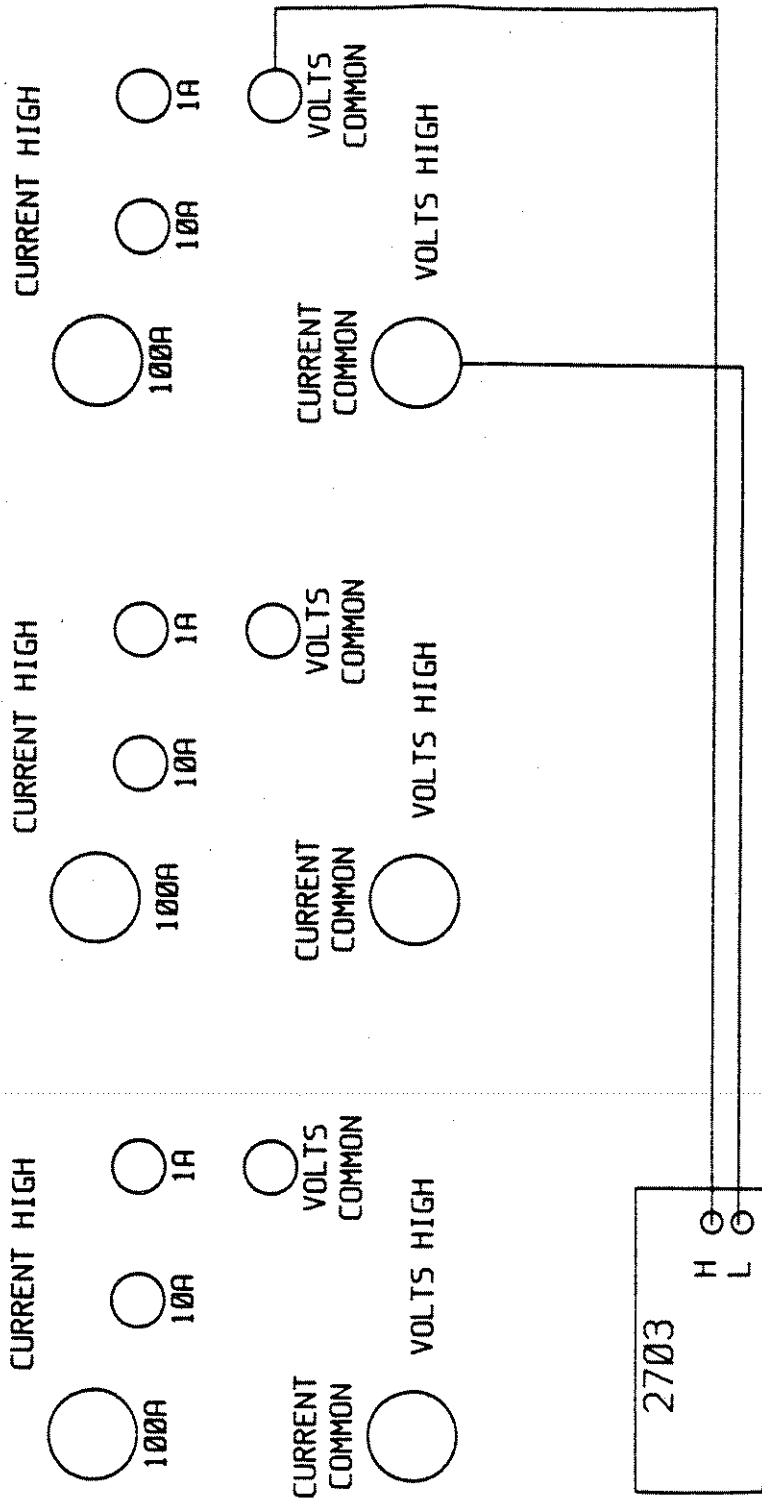
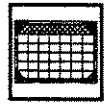


FIGURE 8 - 1 VOLTAGE CALIBRATION CHANNEL A



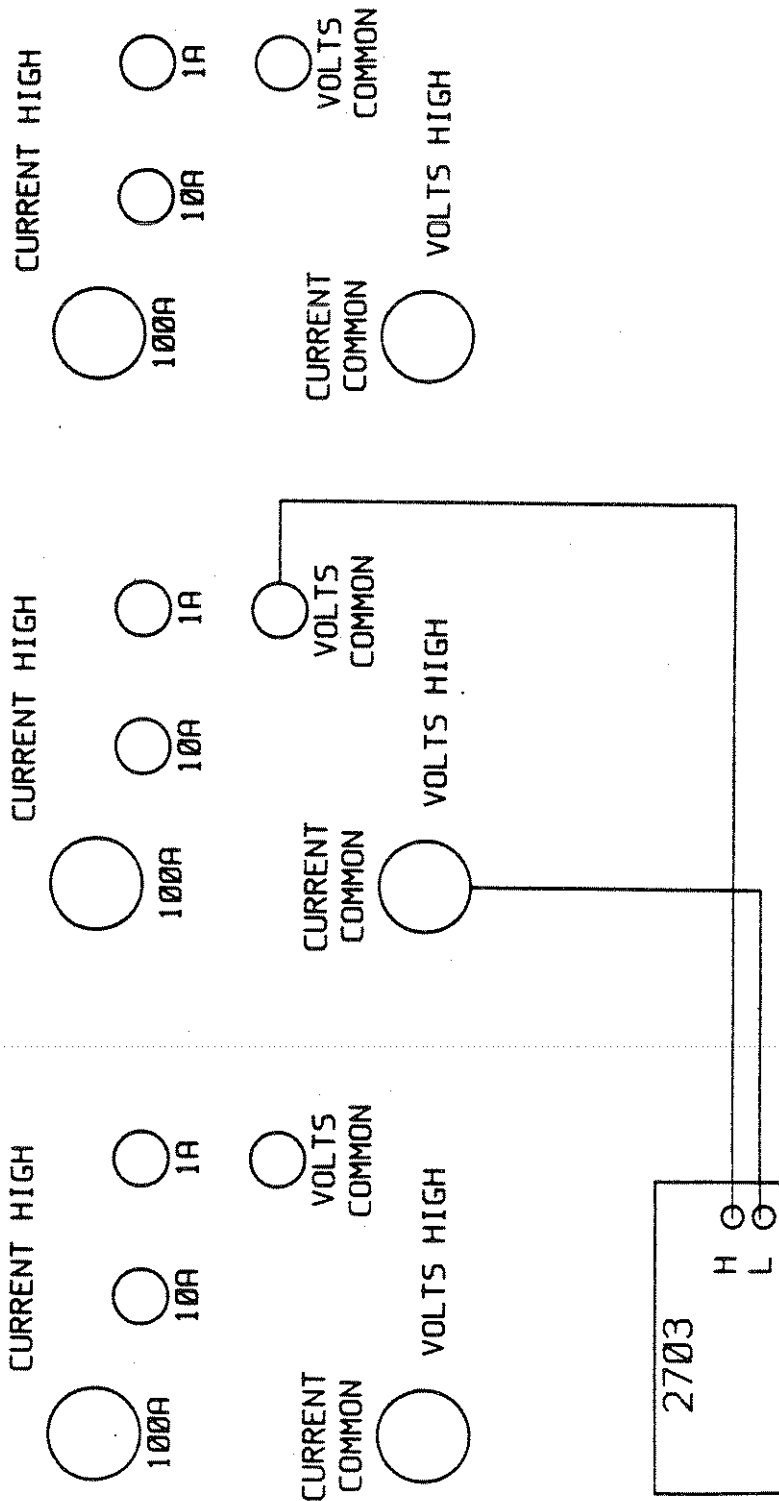
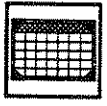
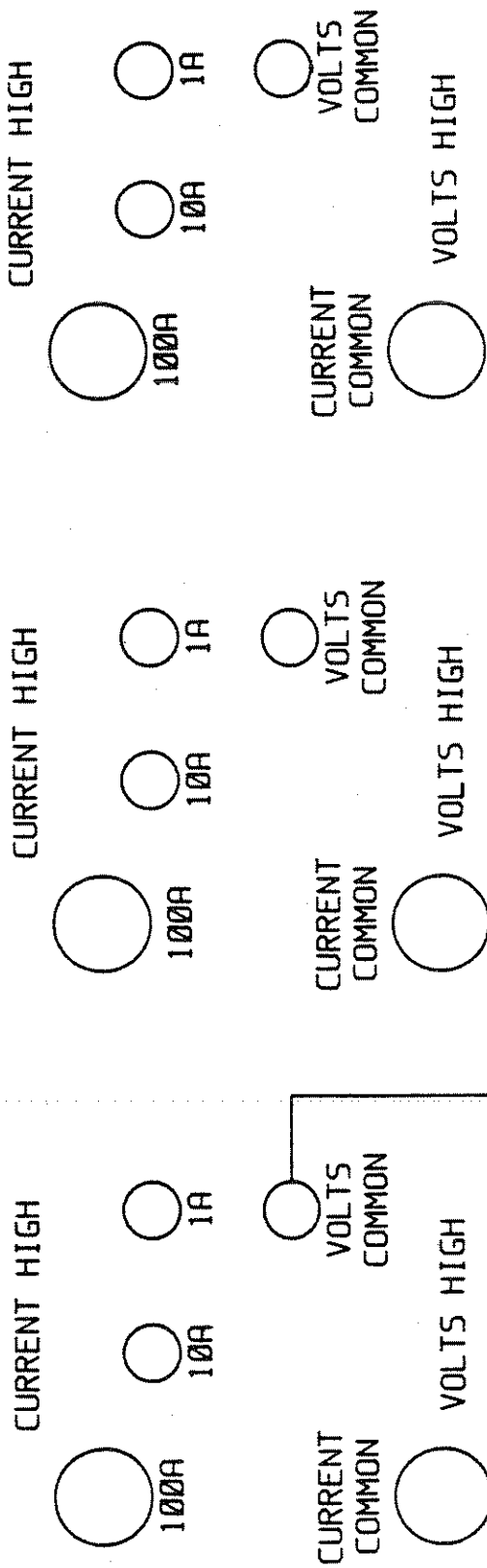


FIGURE 8 - 2 VOLTAGE CALIBRATION CHANNEL B





VOLTAGE CALIBRATION CHANNEL C

FIGURE 8 - 3



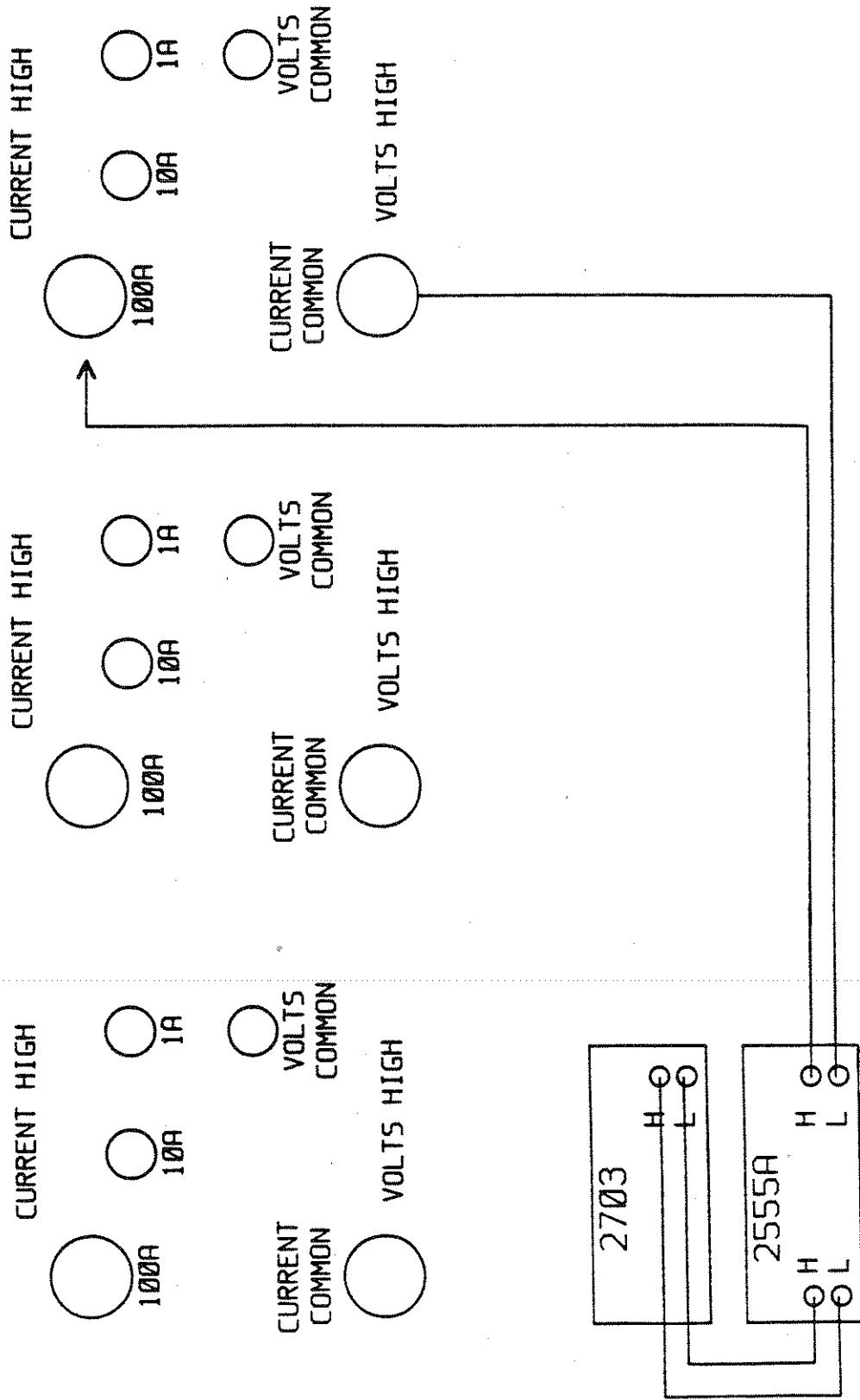
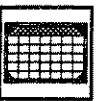


FIGURE 8 - 4 CURRENT CALIBRATION CHANNEL A

FIGURE 8 - 4



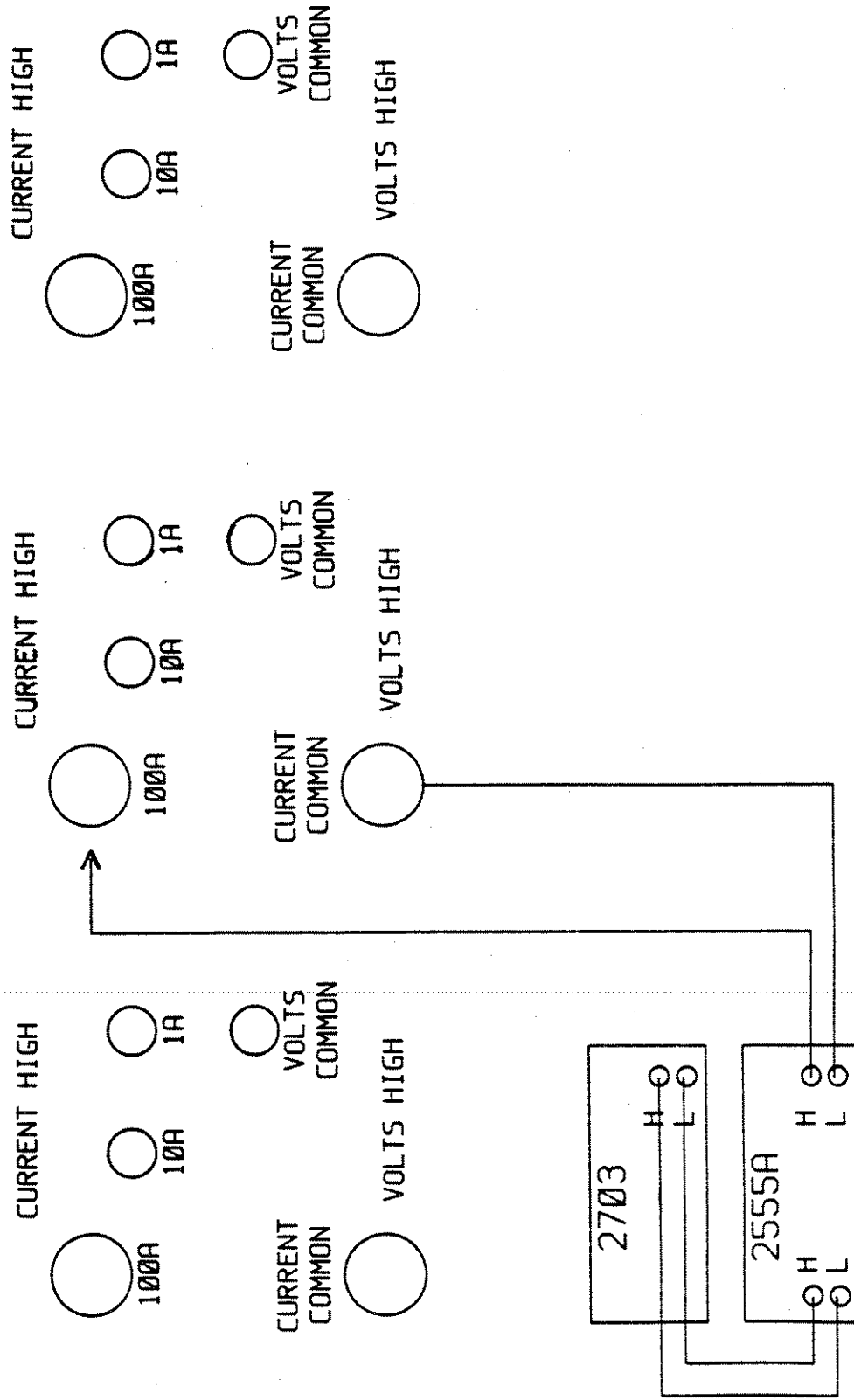
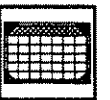


FIGURE 8 - 5 CURRENT CALIBRATION CHANNEL B

FIGURE 8 - 5



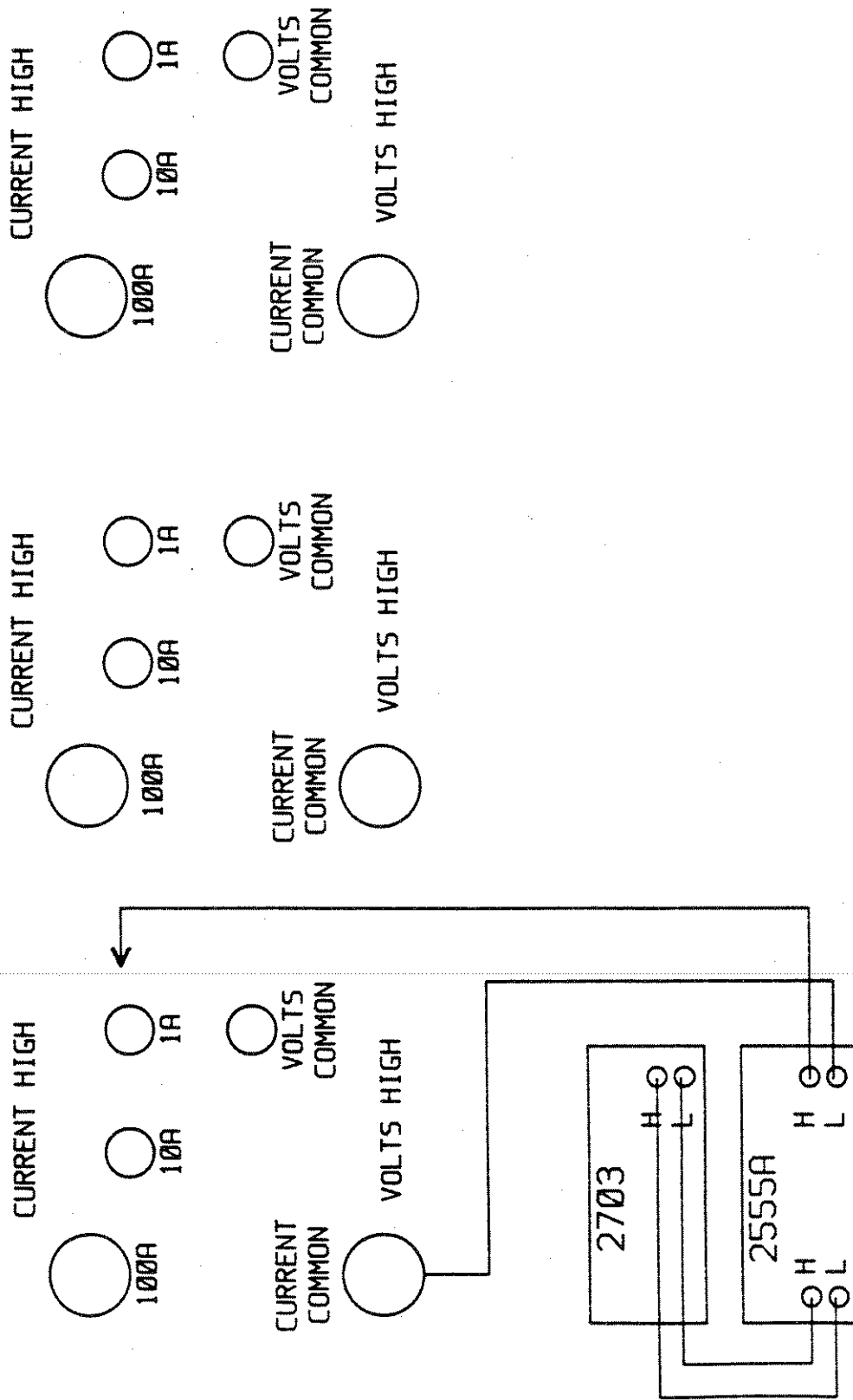
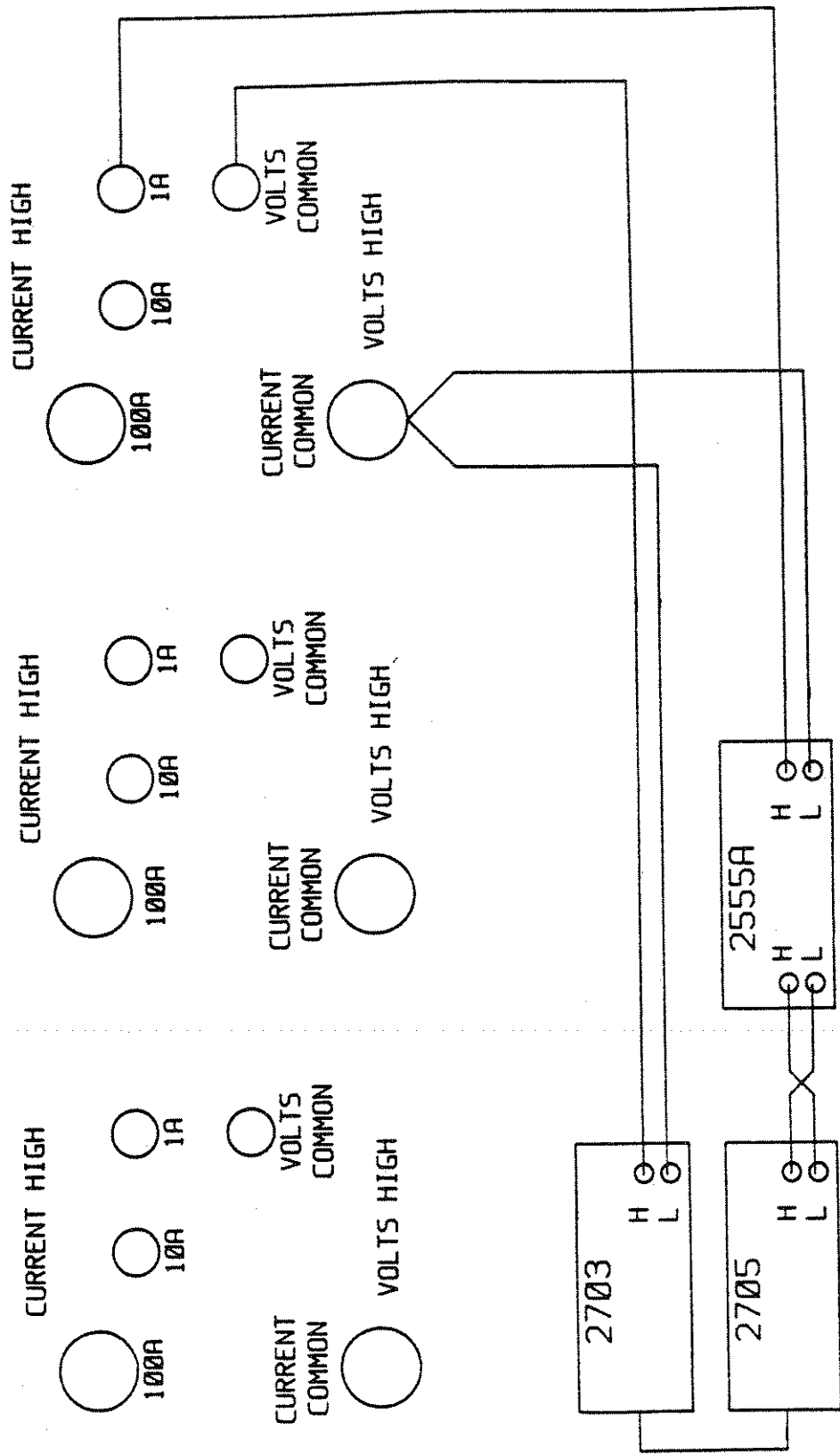


FIGURE 8 - 6 CURRENT CALIBRATION CHANNEL C







POWER CALIBRATION CHANNEL A

FIGURE 8 - 7



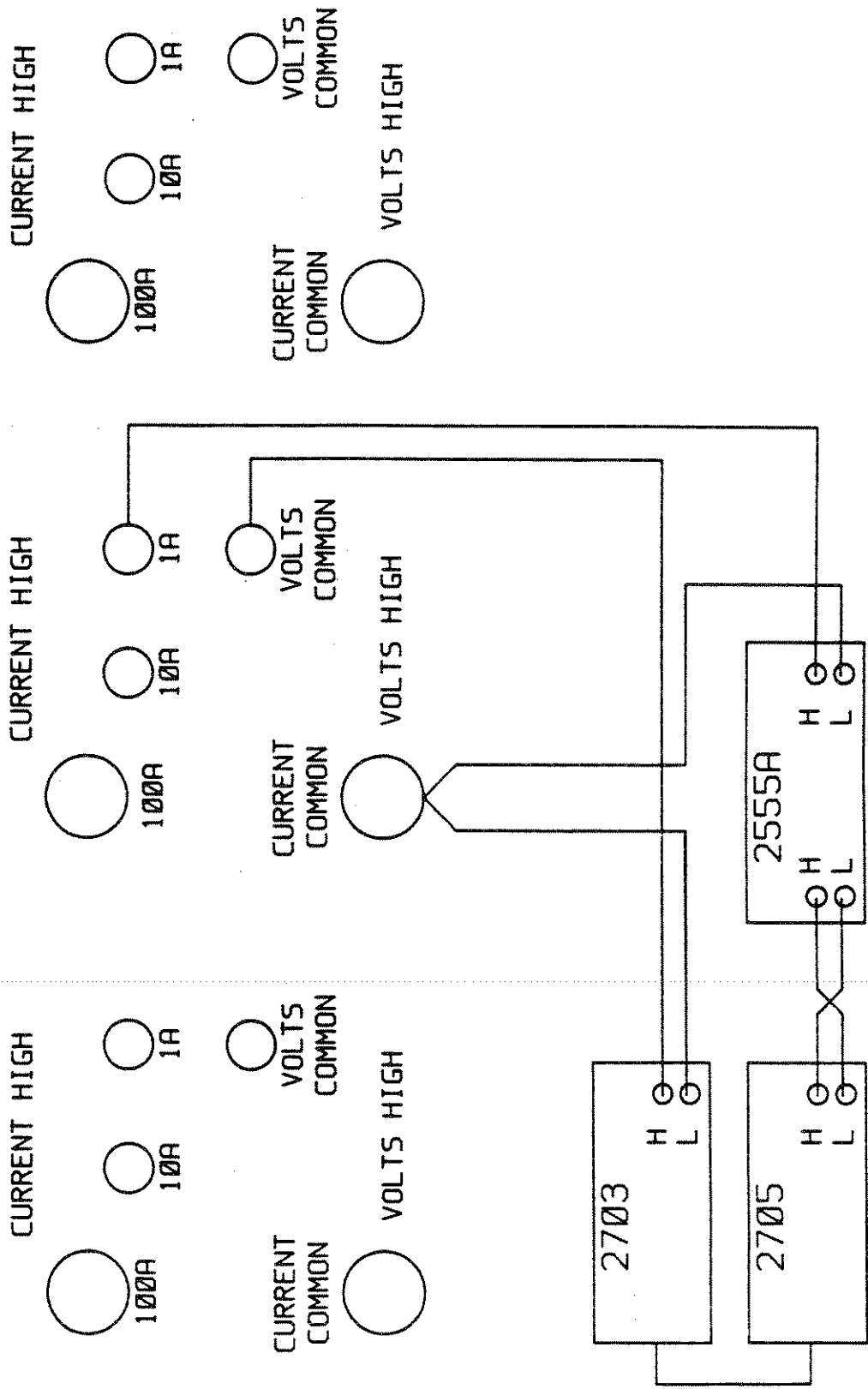
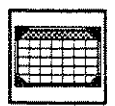


FIGURE 8 - 8 POWER CALIBRATION CHANNEL B



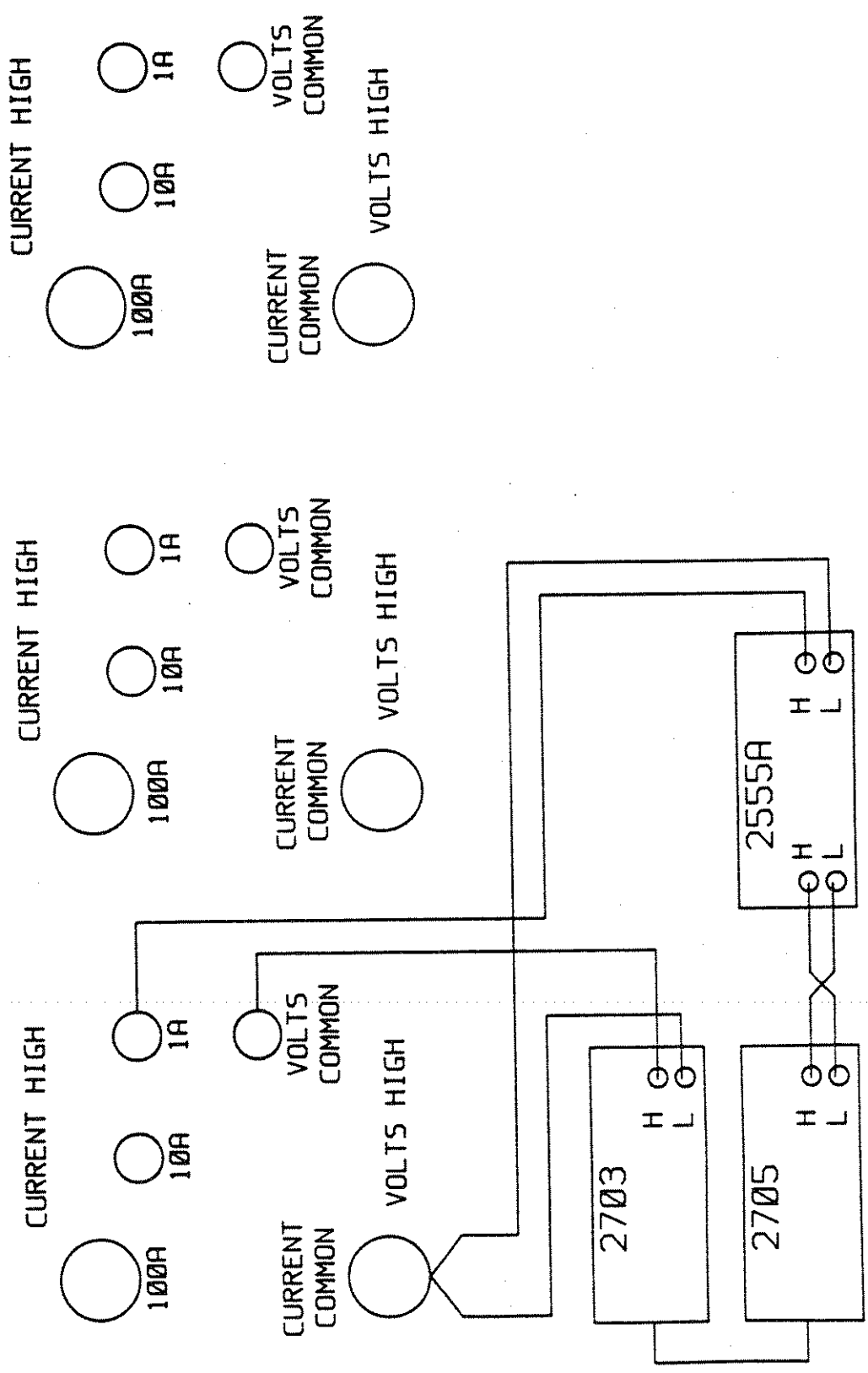
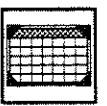


FIGURE 8 - 9 POWER CALIBRATION CHANNEL C



## SECTION IX MAINTENANCE AND TROUBLESHOOTING

---



### 9-1. General

The following paragraphs provide the information required to perform the required periodic maintenance and basic guidelines for troubleshooting the 2300.

### 9-2. Periodic Maintenance

The 2300 requires little periodic maintenance other than regular performance of the calibration procedure of Section 8. Maintenance which may be required is discussed in the following paragraphs.

#### 9-2-1. Cleaning

It is recommended that the 2300 be operated in a clean environment. However, if the environment is dusty periodic cleaning of the unit will be necessary.

Loose dirt or dust which has collected on the exterior surfaces of the 2300 may be removed with a soft cloth or brush. Any remaining dirt may be removed with a soft cloth dampened in a mild soap and water solution. **Do not use abrasive cleaners.**

The front panel may be cleaned with a soft cloth and a "Windex" type cleaner. **Do not use petroleum based cleaners on the front panel.**

If required, the 2300 interior may be cleaned by blowing with dry compressed air.

If the 2300 has become heavily soiled with dirt or by other contaminants it is recommended that the unit be completely overhauled. Contact your local Valhalla Scientific Service Center for details.

### 9-2-2. Tightening

Tightness of connections to the input terminals is important for safety and reliability of measurements. Loose connections, especially when working with high current levels, may cause excessive temperatures to build up on the shunt input terminals. This contact resistance also requires the source to supply additional power in order to overcome it. It is recommended that power be periodically removed and the integrity of connections checked as they may have become relaxed.

### 9-3. Troubleshooting

The following paragraphs give basic procedures for troubleshooting and component replacement in the 2300.

#### 9-3-1. Component Replacement

The 2300 accuracy and reliability can only be maintained if the following precautions are taken when changing a component:

- ▲ Remove all power from the instrument and input terminals before attempting component replacement.
- ▲ Use only the specified component or its exact equivalent. Spare parts may be ordered from your nearest Valhalla Scientific Service Center by referring to the Valhalla part number listed in the Parts List section at the back of this manual. Please provide the type and serial number of the instrument with your order.
- ▲ Use only 63/37 rosin core electronic grade solder with a 50W (or lower) maximum power soldering iron.

- ▲ Many of the semiconductor devices used in the 2300 can be damaged by static discharges. Thus the user should follow strict static-free procedures to ensure that damage does not occur.
- ▲ When resoldering components the user must ensure that the highest possible quality soldering is used. A dry joint may cause the 2300 to drift outside of its specification limits.
- ▲ Minimize handling of components and assemblies. Transport and store components in the original containers.
- ▲ Discharge static build-up on the user and instrument prior to handling components or assemblies.
- ▲ Handle the components such that all (or as many as possible) of the leads are in contact with the user.
- ▲ Never slide a component over a surface.
- ▲ Use a grounded tip soldering iron and ensure that the assembly being (de)soldered is also grounded.

### 9-3-2. Finding the Faulty Component

**WARNING**  
**HAZARDOUS VOLTAGES**  
**MAY BE**  
**PRESENT INSIDE THE 2300**

It is not possible to anticipate all failure modes of the components in the 2300. Therefore, the servicing technician should become familiar with Section 10 of this manual. Experience has shown that apparent malfunctions are often the result of misinterpretation of the specifications or operating procedures of the unit. Check to be sure that the cables and other test equipment are in good order before attempting to repair the 2300.

Knowledge of circuit operation is a prerequisite for efficient fault finding in the 2300. As a servicing aid, the troubleshooting chart below lists a number of fault symptoms and the possible causes. If the exhibited fault symptom is not shown or a check of the possible causes does not locate the source of the problem, then it will be necessary to employ normal troubleshooting procedures.

<u>SYMPTOM</u>	<u>POSSIBLE CAUSES</u>
No display	Blown fuse; Earthy power supplies; A-D converters; DBIC4 (clock)
Display Overload	A-D converter reference; Earthy power supplies; A-D converters; PCB connectors
Overload LED illuminated with no inputs	Overload Detection; MBIC11-13; All phases - MBCR17-18, MBIC9-10 Single phase - Signal Processing PCB Power Supplies; PCB connectors
Single Phase Volts, amps or watts not functioning or out of tolerance	Signal Processing Board or Receiver for phase; PCB connectors
All phases volts, amps, or watts not functioning or out of tolerance	Circuits after MBK1-MBK9 MBIC5 for amps MBIC2 for volts MBIC7 for watts Power Supplies; PCB connectors
Sudden change in calibration affecting all displays, all ranges	DBIC18; Display Board Reference
No current reading	Check the in-line fuses for the one or more phases Low Shunt. They are located behind when using the Low and underneath the shunt assembly.
Shunt only	Replace with a 5A fuse maximum.

**Note:** The signal processing PCB's may be interchanged to aid in troubleshooting. Care should be taken to ensure that all connector pins mate properly with the sockets on the signal processing PCB's before applying power to the instrument. The signal processing PCB's should be marked with their original positions in the chassis ( $\phi A, \phi B, \phi C$ ) before unplugging them. Be sure to reinstall them in their original positions after troubleshooting.



## SECTION X THEORY OF OPERATION

---



### 10-1. General

This section gives the theory of operation of the circuitry used in the 2300, and is divided into two parts. The first part is a functional description referring to the block diagram shown in Figure 10-1. The second is a detailed description referring to the schematic diagrams found at the back of this manual.

### 10-2. Functional Descriptions

This section describes the general operation of each section of the 2300. The paragraph titles refer to the block diagram, Figure 10-1.

#### 10-2-1. Current Amplifier

The current amplifier boosts the small signals from the current shunts to workable levels. This stage provides a DC voltage proportional to the RMS value of the current to the isolator stage along with an amplified version of its input to the power multiplier stage. The gain and input of this stage is controlled by the control isolator stage.

#### 10-2-2. Voltage Amplifier

The voltage amplifier attenuates the input at the voltage terminals down to workable levels. This stage provides a DC voltage proportional to the RMS value of the voltage to the isolator stage along with scaled versions of the input to the power multiplier stage. The gain of this stage is controlled by the control isolator stage.

#### 10-2-3. Power Multiplier

The power multiplier instantaneously multiplies the current and voltage signals,

producing the watts output. This stage provides a DC voltage proportional to the true power to the isolator stage.

#### 10-2-4. Isolators

The circuitry described so far is floating from chassis ground. The isolators pass the current, voltage and power signals from the floating section to the chassis-grounded section of the 2300.

#### 10-2-5. Control Isolators

This stage isolates the signals required to control the voltage and current amplifiers from chassis ground through the use of opto-isolators.

#### 10-2-6. Receivers

This stage converts the outputs of the isolators back into DC voltages for the watts, amps and volts ranging sections. This stage also selects which signal processing PCB's data will be displayed. The receivers also sum the watts data for three-phase displays.

#### 10-2-7. Watts, Amps, Volts Ranging

These three stages scale the power, voltage, and current data to provide levels usable by the A to D converters.

#### 10-2-8. Power Supplies

This section powers the circuitry of all other sections of the 2300. The power supply has four separate sections, one chassis ground-referenced supply for the A to D's and three fully floating supplies for the three signal processing PCB's.

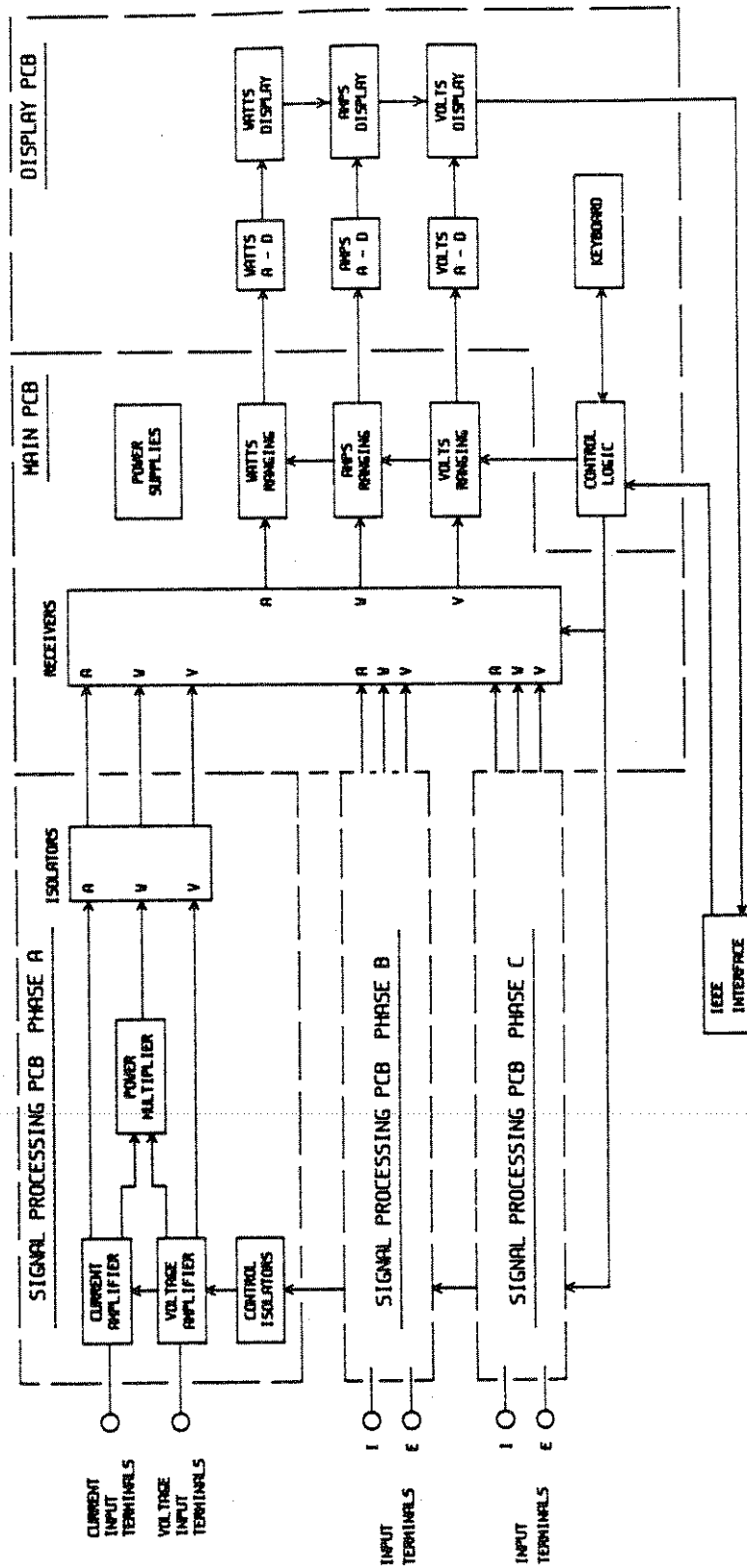


FIGURE 10 - 1 2300B BLOCK DIAGRAM



### 10-2-9. A to D Converters and Displays

The three A to D converters convert the analog voltage, current and power signals into digital data for display. The A to D converters are of the dual slope integrating type.

### 10-2-10. Control Logic

This stage accepts inputs from the keyboard and IEEE interface to control the 2300 ranges. This stage also drives the front panel LED's.

### 10-2-11. Keyboard

The front panel push-buttons are scanned by the keyboard circuitry. Key data is sent to the control section for range and display selection.

### 10-2-12. IEEE Interface

The IEEE interface contains the circuitry necessary to control and read the 2300 via the IEEE-488 bus.

## 10-3. Detailed Descriptions

The paragraphs that follow use the same functional blocks as used in 10-2, but give full detail on operation down to component level. Throughout this section, it is assumed that the reader has a knowledge of electronics and is familiar with the operation of the 2300 from the front panel.

### 10-3-1. Current Amplifier

The schematic for this section may be found on drawing number 2300-070. IC1 is a differential four input analog multiplexer. Pins 9 and 10 are binary control lines selecting which pair of inputs are connected to the outputs. The current shunts are connected across the inputs to IC1. Pins 1 and 12 are connected across the 1 amp shunt, pins 5 and 14 across the

10 amp shunt, and pins 2 and 15 to the 100 amp shunt. Resistive networks R5-R6, R7-R8 are used to compensate for the resistance tolerance of the shunts. The outputs of IC1 are applied to the amplifier stage composed of IC's 2 and 3 and their associated components.

The gain of the stage is determined by the ratio of R11 and the series combination of R16 and R17. When different current ranges are selected, relays K1 and K2 are energized. Series combinations R12-R13 and R14-R15 modify the gain so that the output of IC2 is always 5 volts RMS at full scale of the range selected.

IC3 is connected as a unity gain follower buffering the output of IC2 from the RMS converter, current peak detector, and power multiplier.

IC10 and its associated components form an RMS-to-DC converter. Its output is a DC voltage which is equal in value to the RMS AC voltage input. If the RMS converter or multiplier are operated outside of their range of input levels, inaccurate readings may result. To prevent this source of error, peak comparator IC5 monitors the output of IC3. If the peak exceeds the limits set by R33 to R36, opto-isolator IC6 is activated, which in turn drives the front panel mounted peak overload LED.

### 10-3-2. Voltage Amplifier

The schematic for this section may be found on 2300-070. The voltage amplifier is composed of IC4 and its associated components. The measured voltage is attenuated by resistors R21-R23 to levels compatible with IC4. The amplifier's gain is set by the ratio of R24 to the series resistor combinations selected by relays K3-K5. With all relays de-energized the gain of the stage is unity. Series combinations R29-R30, R27-R28, R25-R26 modify the gain so that





the output of the stage is always 5 volts RMS at full scale of the range selected.

IC8 and its associated components form an RMS-to-DC converter. Its output is a DC voltage which is equal in value to the RMS AC voltage input. If the RMS converter or multiplier are operated outside of their range of input levels, inaccurate readings may result. To prevent this source of error, peak comparator IC7 monitors the output of IC4. If the peaks exceed the limits set by R33 to R36, opto-isolator IC6 is activated, which in turn drives the front panel peak overload LED.

### 10-3-3. Power Multiplier

The schematic for this section may be found on 2300-070. IC9 and its associated components form the power multiplier. The output of the multiplier is one tenth the product of its inputs. With the inputs from the current and voltage amplifiers at 5 volts the multiplier output will be 2.5 volts. R39 and C18 smooth the multiplier output.

### 10-3-4. Isolators

The schematic for this section may be found on 2300-070. The DC analog levels of voltage, current and power are transmitted across the floating earthy barrier by a voltage-to-time converter. The isolators produce a constant frequency, variable duty cycle wave to drive the opto-isolators to bridge the barrier.

The DC voltage to be isolated is compared to a very linear triangle wave by IC13. The output of IC13 is a variable duty cycle pulse. The pulse width is equal to the period of time that the triangle wave is above the DC voltage. If the voltage increases, the pulses become narrower. If the voltage drops, the pulses

become wider. The duty cycle will be 50% for zero DC voltage.

IC's 11, 12 and their associated components form a precision triangle generator. The triangle's frequency is about 5KHz. The actual frequency does not matter. The triangle amplitude is set by zener diodes CR4 and CR5. IC12 is configured as an integrator and IC11 as a comparator. Positive feedback around the integrator-comparator combination produces oscillations generating a precise triangle at the output of IC6.

### 10-3-5. Control Isolators

The schematic for this section may be found on 2300-070. The gains of the current and voltage amplifiers along with the current shunt selection are controlled by the front panel keyboard. The control signals are isolated by opto-isolators IC17 and 18. Transistors TR1-5 buffer the opto-isolator outputs to drive the gain selection relays K1-K5.

### 10-3-6. Receivers

The schematic of this section may be found on sheets 1 and 2 of 2300-071. The receivers convert the variable duty cycle isolator outputs into DC voltages. The opto-isolator outputs are squared by comparator IC103. The outputs of IC103 are clamped to precision levels by diode pairs CR116-CR115, CR114-CR113, CR112-CR111. The clamp levels are established by zener diodes CR17 and CR18 and their associated components. The outputs of the clamps are applied to second order low pass filters IC104-IC106 and their associated components. The outputs of the filters are DC voltages proportional to watts, volts, and amps. Relays K1-K9 select which isolator output is applied to the summing amplifier IC4 and the ranging circuits.



IC4 sums the three watts outputs to provide total watts displays for 3-phase 3-wire and 3-phase 4-wire measurements. Relay K10 selects the gain of IC4 for optimum display resolution.

The outputs of the voltage and current comparators are also applied to overload detection circuits. These detectors monitor the presence of the variable duty cycle pulses. If the isolators are being over-driven (inputs voltage or current limits are exceeded), the pulses will be interrupted.

The pulses from IC103 continually trigger the two sections of IC11. External timing components R56-C13, R57-C14 set the period of the one-shots slightly longer than the period of the input pulses. As long as the pulses continue, the one-shot outputs will remain high. If the pulses stop, the one shot output goes low which illuminates the front panel peak overload LED's.

#### 10-3-7. V-A-W Ranging

The schematic for this section is shown on 2300-071 sheet 1. The ranging circuits are composed of IC's 5-8 and their associated components. The voltage, current, and power signals from the receivers are applied to resistor strings R10-R16, R17-R25, and R26-R42. Taps from the resistor strings are selected by analog multiplexers IC5-7. The multiplexer outputs are applied to the A to D converter inputs for display. The voltage and current outputs of the receivers are approximately 5 volts full scale for all ranges. The power output may be 0.75 volts, 2.5 volts, or 5 volts full scale depending on the voltage and current range selected and whether a single or three-phase display is selected.

The A to D converters require 1VDC input for a display of 10000. The taps on the resistor strings attenuate receiver

output voltages to the values required for a full scale display.

#### 10-3-8. Power Supplies

The schematic for this section may be found on sheet 2 of 2300-071. The chassis referenced circuits in the 2300 (main board, display board, and IEEE-488 board) are powered by the earthy supplies composed of transformers T1 and T2 and their associated components. Each transformer has two primary windings that are connected in series for 240 volt operation or parallel for 120 volt operation.

The secondary of T1 is rectified by diodes CR1-CR4 and smoothed by capacitors C1 and C2. IC's 1 and 2 regulate the raw DC voltage providing regulated  $\pm 15\text{VDC}$ . The  $\pm 7.5\text{VDC}$  rails are provided by resistive dividers R1 to R4. The secondary of T2 is rectified by diodes CR5 and CR6 and smoothed by C5. IC3 regulates the raw DC providing the  $+5\text{VDC}$  rail.

Each signal processing PCB is powered by its own separate floating supply. All three supplies are identical therefore only the phase A supply will be described. The secondary of T101 is rectified by diodes CR101-CR104 and smoothed by C101 and C102. IC's 101 and 103 regulate the raw DC voltages providing the floating  $\pm 15\text{VDC}$  rails.

#### 10-3-9. A to D Converters and Displays

The schematic for this section may be found on 2300-072, sheets 1-3. The operation of the voltage, current, and watts A to D converters are the same. Only the voltage A to D converter will be described. The A to D converter is comprised of IC's 1, 2, and 3, and their associated components. The A to D clock is provided by IC4 which



is common to all A to D's and has an output of 100KHz at pin 8.

The operating cycle of the dual-slope integrating A to D converter is divided into three stages whose duration is set by the clock. During the first, or auto-zero stage, the analog input is internally shorted to analog ground and C3 is charged to the integrator's output offset voltage. This is connected to the integrator's non-inverting input which subtracts from the analog input, cancelling the offset.

During the second, or input-integrate stage, the input voltage is connected to the integrator and IC2 integrates the input for a precise time (10,000 counts of the clock) by charging C2 linearly toward the input voltage. The waveform on C2 is a linear ramp with a slope proportional to the input voltage. Thus, the charge on C2 at the end of this phase is also proportional to the input voltage.

During the third, or reference-integrate stage, a precise reference voltage of polarity opposite to the input voltage is applied to the integrator. IC2 begins discharging C2 toward the reference voltage. Because the reference voltage is fixed, the discharge slope is always the same. Therefore, the time required to discharge C2 back to zero is proportional to the original input voltage.

The time is measured in IC3 by counting the oscillator pulses. The IC2-IC3 set is designed to give a count of 10,000 for a 1.0000VDC input. The count, which is numerically equal to the value of the input to IC3, is displayed as the measured voltage. The reference integration counts, which are accumulated in an internal counter of IC3, are latched into a multiplexer also inside IC3, at the end of the count period.

During the next series of auto-zero and integration periods, each digit of the counts previously latched into the multiplexer are sequentially placed on the BCD outputs of IC3 and on the inputs of IC1, a binary-to-seven segment decoder/driver. While the most significant digit data is applied to IC1, transistor TR1 is turned on by the digit output of IC3 to provide the anode voltage for DS1. When the next digit data is applied to IC1, TR1 is turned off and TR2 is turned on to provide the anode voltage for DS2. The sequence is continued for TR3/DS3, TR4/DS4 and TR5/DS5 and then repeated. The repetition rate is sufficiently high that all digits appear to be continuously illuminated.

When 3 $\phi$  3-wire or 3 $\phi$  4-wire displays are selected, the voltage and current displays are blanked by the control logic. The logic places a low on pin 4 of IC1, disabling its outputs. The "9" bars of the displays are illuminated by CR22.

### 10-3-10. Control Logic

The schematics for this section may be found on 2300-072 sheets 1, 2 and 3. The outputs from either the keyboard or the IEEE interface are selected by IC's 7, 15, and 23. The remote/local line from the IEEE interface determines which signals drive the control logic.

The outputs of IC7 are decoded by IC8 to drive the voltage range LED's, voltage display decimal points, and signal processing board voltage ranges. The outputs of IC7 also drive IC20 and IC8 on the main board.

The outputs of IC15 are decoded by IC16 to drive the current range LED's. The outputs also drive IC13 and IC20. The outputs of IC13 drive the current display decimal points and the signal processing board current ranges.



The outputs of IC23 are decoded by IC24 to drive the display selection LED's. Diode logic is used to control the phase selection relays. The outputs are also used to blank the voltage and current displays for 3-phase displays. The output of IC23 also drives IC20 which controls the power display decimal points and KW-W LED's.

#### 10-3-11. Keyboard

The schematics for this section may be found on 2300-072 sheets 1, 2 and 3. The front panel push-buttons are scanned by IC's 6, 14, and 22. These IC's scan the voltage, current and display selection push-buttons, respectively. Their outputs are BCD coded signals corresponding to the last push-button pressed. A power-up reset circuit composed of TR20, C34, R53, and R54 momentarily energizes relays K1-K3. The contacts of these relays are connected across the 600 volt, 100 amp and  $\phi$ A push-buttons to select these ranges on power-up.

#### 10-3-12. IEEE Interface

The schematic for this section may be found on 1000-070. The IEEE interface is composed of microprocessor IC5 and its support chips. IC's 2-4 interface the microprocessor bus to the IEEE bus. The microprocessor program is contained in EPROM IC6. The microprocessor bus is interfaced to the 2300 display board by peripheral interface adapters IC's 8-11. The microprocessor accepts commands from the IEEE bus and converts them to data that the 2300 can understand. Description of the internal workings of the IC's on this board is beyond the scope of this manual. The manufacturer's data sheets should be consulted for further information.

#### 10-3-13. Option IOX

The schematic for this section may be found on 2300-073. The outputs of the

current and voltage receivers are applied to unity gain inverting amplifiers IC1-3 and their associated components. The gain and offset of each amplifier are adjustable to allow calibration. The outputs of the watts receivers are applied to inverting amplifier IC's 4-5 and their associated components. The watts receivers are also applied to summing amplifier IC6 and associated components to provide total-watts analog output.

#### 10-4. Models 2301, 2300L and 2301L

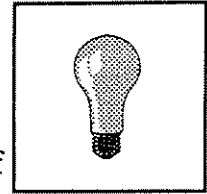
The circuit descriptions above referred to the drawings of Model 2300. The Models 2301, 2300L and 2301L use identical circuitry and the descriptions apply to these models as well. The following differences should be noted:

- 1) The signal processing board schematic is the same.
- 2) The main PCB schematic for Models 2301 and 2301L is drawing number 2301-071.
- 3) The display PCB schematic for Models 2301 and 2301L is drawing number 2301-072.
- 4) The main PCB and display PCB assembly drawings for Models 2301 and 2301L are drawing numbers 2301-601 and 2301-602.
- 5) Refer to the Parts List section of this manual for the corrected parts lists for these models.



## SECTION XI SPECIAL APPLICATION NOTES

---



The following pages contain notes specific to certain applications. Review of these notes is recommended in order to obtain maximum utility and safety from the 2300 Series of Power Analyzers. The topics are listed below.

### **AN101 Protecting the 2300 from Inductive Loads**

- Figure 1. Single-phase Inductive Load Protection (Method 1)
- Figure 2. Three-phase Three-wire Inductive Load Protection (Method 1)
- Figure 3. Three-phase Four-wire Inductive Load Protection (Method 1)
- Figure 4. Single-phase Inductive Load Protection (Method 2)
- Figure 5. Three-phase Three-wire Inductive Load Protection (Method 2)
- Figure 6. Three-phase Four-wire Inductive Load Protection (Method 2)

### **AN102 Using Current and Potential Transformers**

- Figure 1. Current Transformer Connections
- Figure 2. Potential Transformer Connections
- Figure 3. Current Transformer/Potential Transformer Connections

### **AN103 Source Power Measurements**

- Figure 1. Load Power Connections
- Figure 2. Source Power Connections
- Figure 3. Lead Resistance Error Sources
- Figure 4. Minimizing Error Sources

### **AN104 Measuring Phase Currents in 3-Wire Systems**

- Figure 1. Three-phase Three-wire Standard Connections
- Figure 2. Alternate Three-phase Three-wire Connections

### **AN105 Measuring Transformer Loss with the 2300**

- Figure 1. Transformer Loss Connections

### **AN106 Measuring Power Factor and Reactive Volt Amperes**

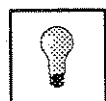
- Figure 1. Watts, VA's, VAR's and PF

## **AN107 Minimizing Error Sources Using Three-Wire Connections**

- Figure 1. Three-wire Digital Power Analyzer
- Figure 2. Digital Power Analyzer Error Sources
- Figure 3. Error Source Reduction
- Figure 4. Measuring Power Loss in Connecting Leads

## **AN108 Measuring Single-Phase Three-wire Power**

- Figure 1. Single-phase Three-wire Power
- Figure 2. Single-phase Three-wire Connections
- Figure 3. Alternate Single-Phase Three-wire Connections



---

**APPLICATION NOTE AN101**  
**PROTECTING THE 2300 DIGITAL POWER ANALYZER**  
**FROM INDUCTIVE LOADS**

---

**101-1. General**

The 2300 Series of Digital Power Analyzers is ideally suited for measuring the power drawn or supplied by large electric motors, generators, transformers, or other types of inductive devices. The testing of highly inductive loads such as these requires that precautions be taken to protect the 2300 from damage due to inductive kickbacks. Very high voltage spikes may be produced when the motor or transformer is disconnected from the source. Spikes may also be produced when a resistive load is disconnected from an inductive source, e.g. a transformer or generator. These spikes can easily exceed the common mode and series mode specifications of the 2300.

**101-2. Protection Methods**

There are two methods of protecting the 2300 from inductive kickbacks. These methods are described in the following paragraphs.

**101-2-1. Switch Protection**

In this method a switch is placed between the 2300 and the inductive load. When disconnecting, the load switch SW1 should be opened first. Switch SW2 can now be opened, disconnecting the 2300 from the source. Figures 1, 2 and 3 detail this type of protection for single and three-phase loads.

**101-2-2. Spark Gap Protection**

In many cases the switch protection method is not practical. Spark gap

protection is the preferred method of protecting the 2300 from inductive kickbacks because the protection is not dependent on the operator. The spark gap(s) dissipate the energy from the inductive kickback. Figures 4, 5 and 6 detail this type of protection for single and three-phase connected loads. When the source is also inductive, e.g. a generator, additional spark gaps should be used. In all cases the spark gaps should be connected close to the load (source) and as far from the 2300 as practical.

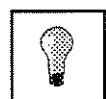
All connections should be made using heavy gauge wire. The spark gap voltage rating should be selected at two to four times the working voltage, 1500 volts maximum. The energy rating in joules depends on the load. For motors, a good rule of thumb is 10 joules per horsepower. For transformers, the energy rating can be calculated from the equation:

$$ENERGY = \frac{1}{2} (LI^2)$$

Where:

Energy = the stored energy in the inductor in Joules  
L = the inductance in Henries  
I = the current used to charge the inductor (supply current) in amps

If the inductance of the transformer is estimated, use a spark gap of higher energy rating than calculated for a margin of safety. Spark gaps are available from C.P. Clare, among others.



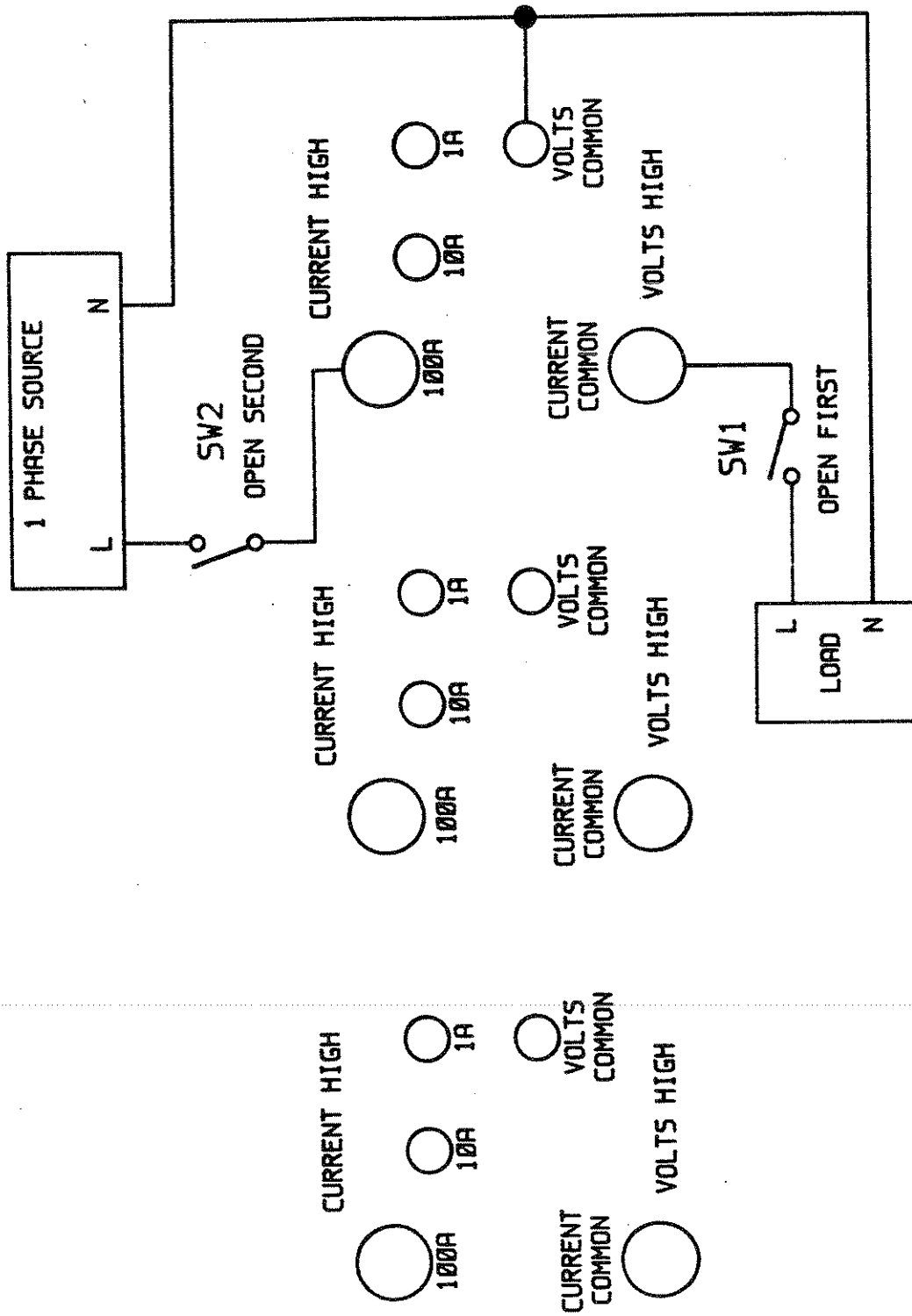


FIGURE 1 SINGLE PHASE INDUCTIVE LOAD PROTECTION METHOD 1



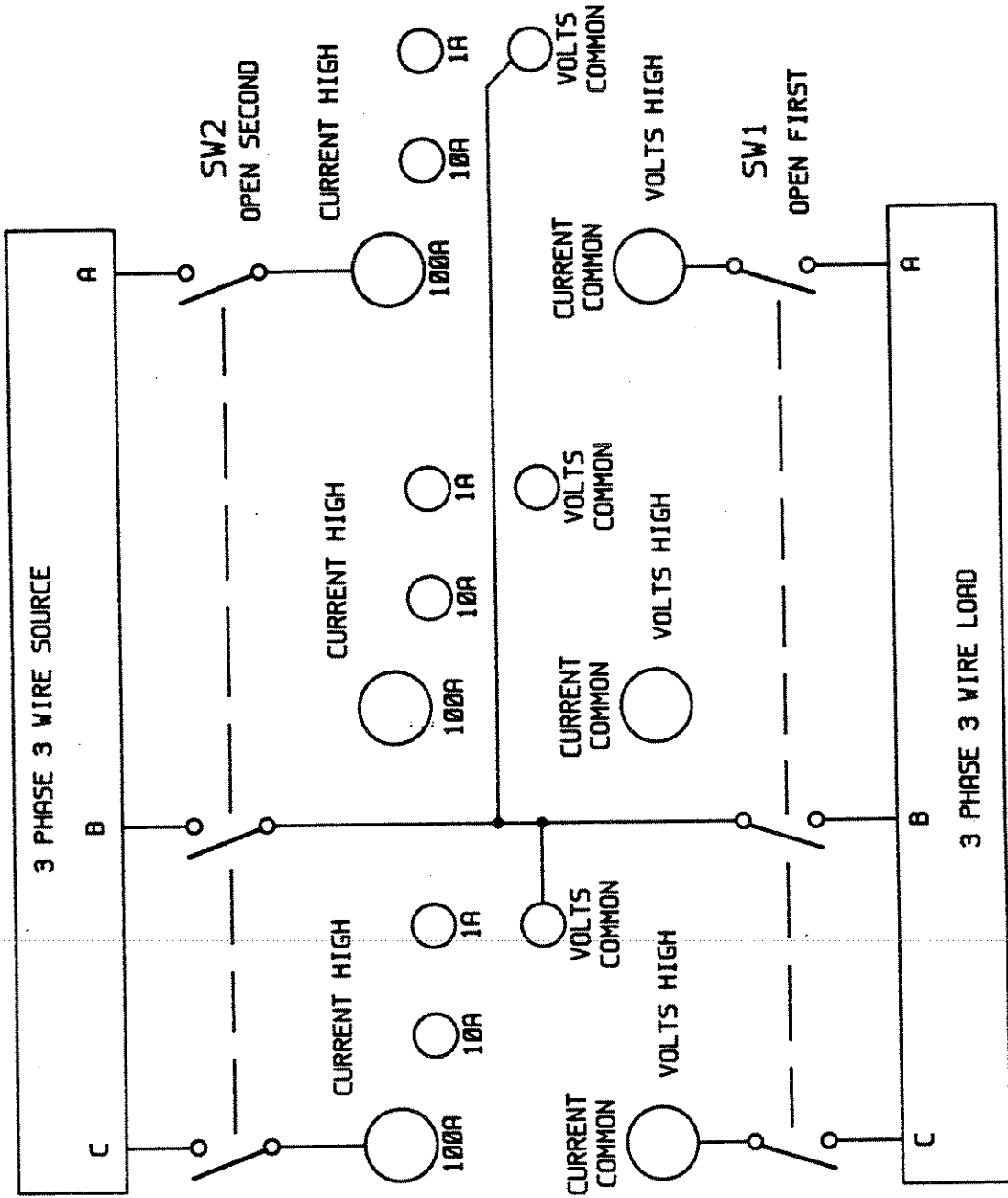


FIGURE 2 3 PHASE 3 WIRE INDUCTIVE LOAD PROTECTION METHOD 1



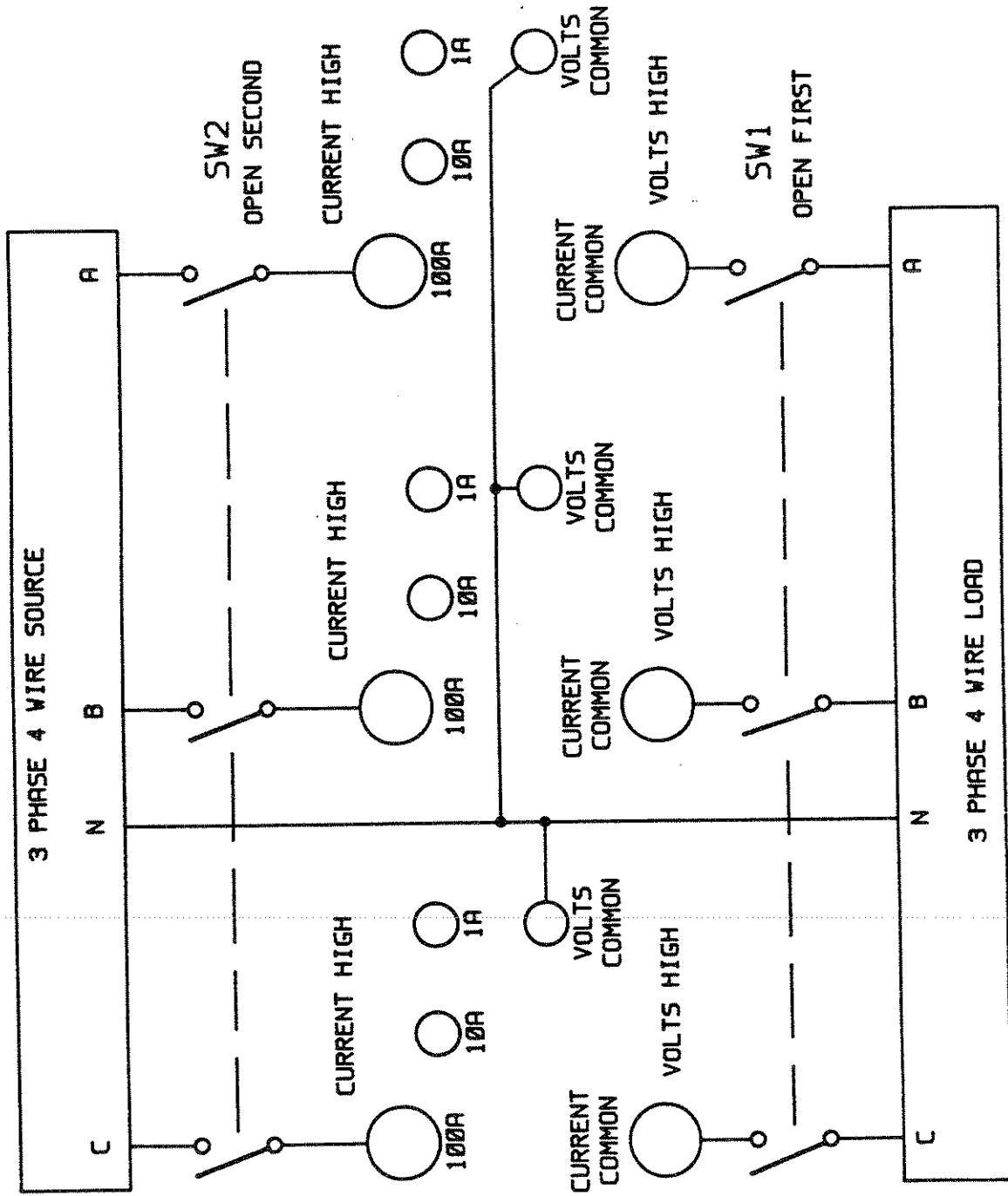


FIGURE 3 3 PHASE 4 WIRE INDUCTIVE LOAD PROTECTION METHOD 1



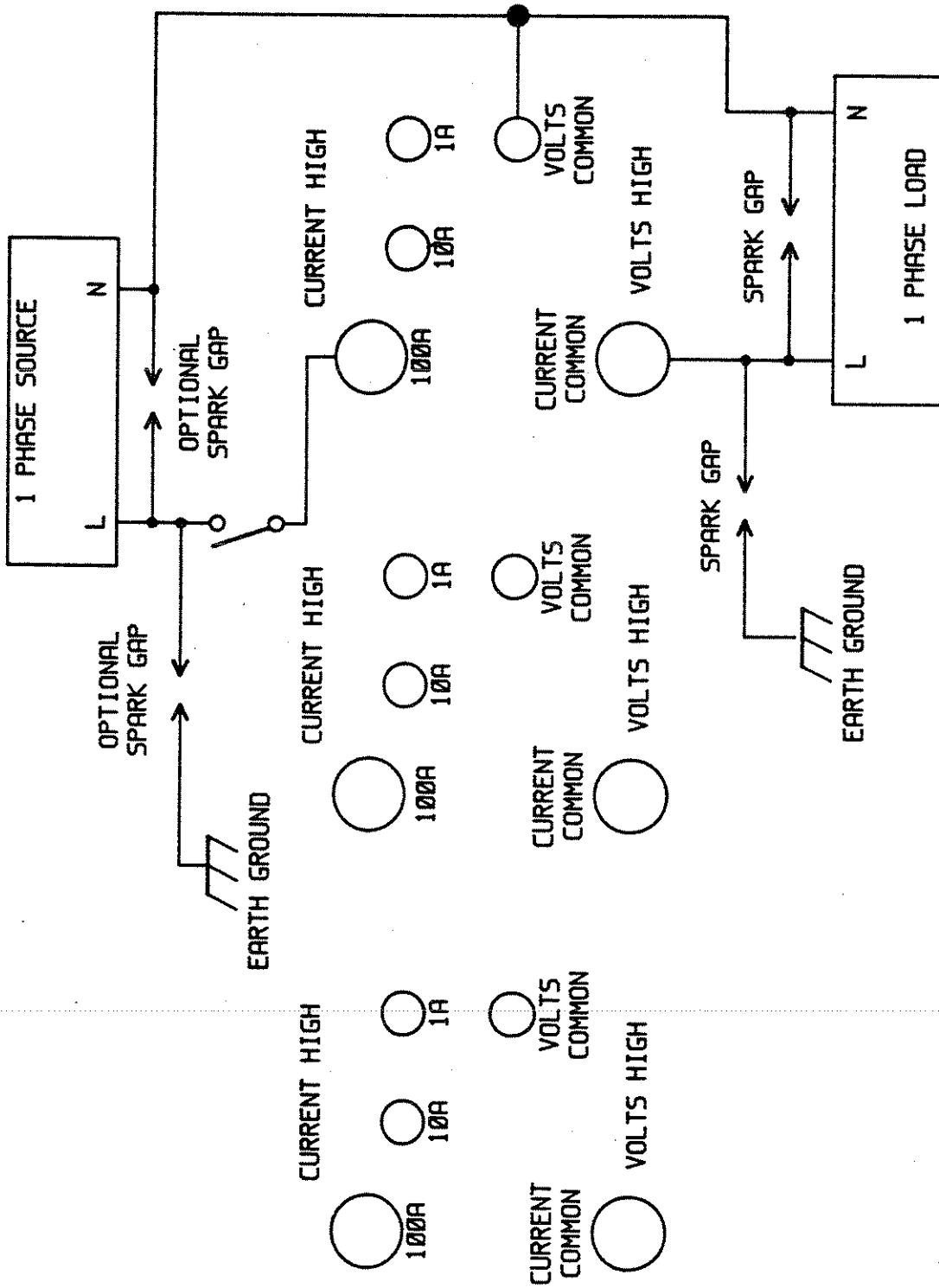


FIGURE 4 SINGLE PHASE INDUCTIVE LOAD PROTECTION METHOD 2



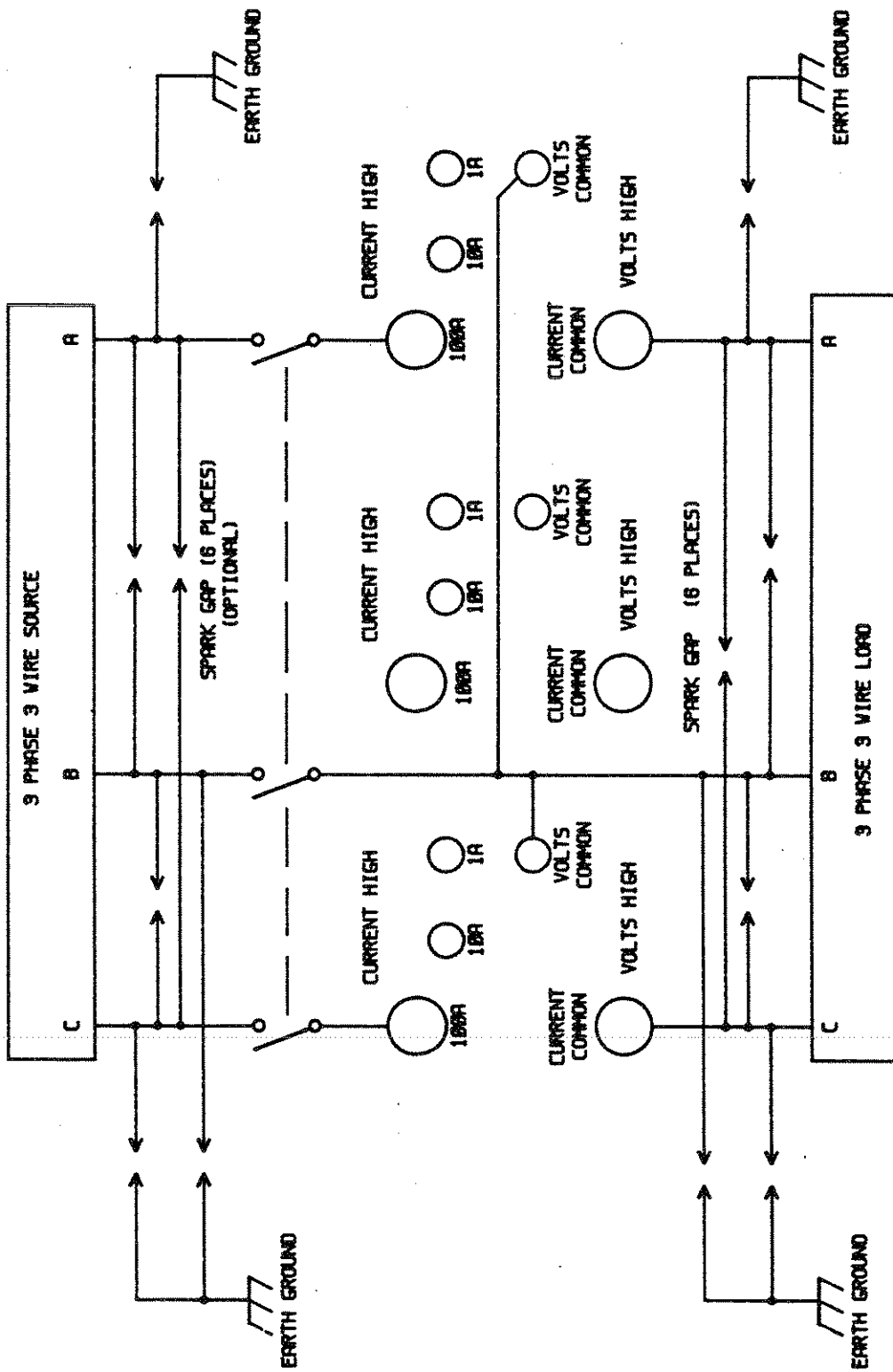
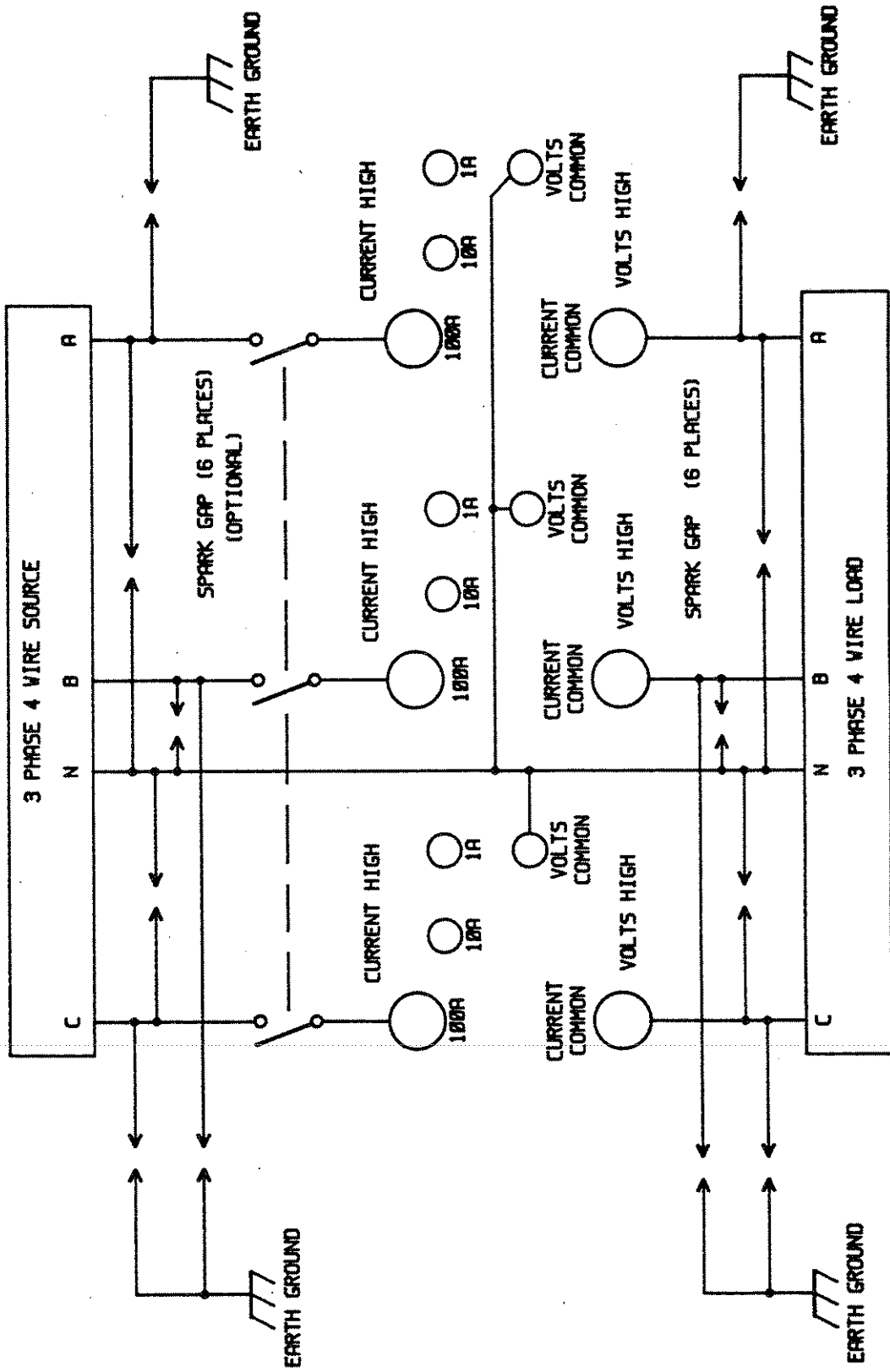


FIGURE 5 3 PHASE 3 WIRE INDUCTIVE LOAD PROTECTION METHOD 2





METHOD 2

3 PHASE 4 WIRE INDUCTIVE LOAD PROTECTION

FIGURE 6



---

**APPLICATION NOTE AN102**  
**USING CURRENT AND POTENTIAL TRANSFORMERS WITH**  
**VALHALLA SCIENTIFIC DIGITAL POWER ANALYZERS**

---

### 102-1. General

Current and potential transformers (CT's and PT's) may be used with any Valhalla Digital Power Analyzer to increase its measurement range. Clamp-on CT's may also be used to simplify power analyzer connections.

### 102-2. Current Transformers

Current transformers (CT's) are used to extend the current measurement capabilities of Valhalla digital power analyzers. CT's are available in many ratios, maximum current ratings and isolation voltages.

There are two styles of CT's available, fixed and clamp-on. Fixed CT's are generally used for permanent test set-ups. The conductor being measured must be disconnected, passed through the center of the CT, and reconnected. Clamp-on CT's are easier to use because they are just clamped around the conductor. The conductor need not be disconnected when using a clamp-on CT.

CT's are also used for isolating the power analyzer from high voltage systems. Many high voltage systems operate at current levels directly measurable by the power analyzer, but with voltages beyond the power analyzer limits. The isolation voltage rating should be at least 1½ times the peak input voltage.

When selecting a CT, try to use decade ratios e.g. 10:1, 100:1, etc. Decade ratios make for easier power analyzer measurements. The user just mentally

moves the current and power display decimal points to the right the appropriate number of places. Of course, non-decade ratios may also be used. If the power analyzer is remotely controlled via the IEEE interface, the controller can apply the CT ratio to the measurements automatically. The maximum current rating of the CT should be selected 1½ times the expected current to allow for high crest-factor waveforms.

The ratio accuracy of CT's is usually about 2%. This is quite a bit wider than the accuracy of a digital power analyzer. The easiest way to improve this accuracy is to measure the actual ratio and use this value when correcting measurements. CT's are low frequency devices, typically 50-400Hz. At high frequencies their phase shift will cause the power measurement to be in error.

### **CAUTION!**

**When using CT's, never open-circuit their secondaries while power is applied!!**

The CT will act like a step-up transformer and may produce lethal voltages which can damage the operator and/or the power analyzer.

Figure 1 illustrates the basic method of connecting a CT to a digital power analyzer. Other methods are shown in Section 6.



### 102-3. Potential Transformers

Potential transformers (PT's) are used to extend the voltage measurement capabilities of Valhalla digital power analyzers. PT's are available in many ratios, maximum voltage ratings and isolation voltages.

PT's can be used to isolate the digital power analyzer from high voltage systems. Some high voltage systems operate at voltage levels directly measurable by the power analyzer but at common mode voltages beyond the power analyzer's limits. The isolation voltage rating should be at least 1½ times the common mode voltage or peak input voltage.

When selecting a PT, try to use decade ratios, e.g. 10:1, 100:1, etc. Decade ratios make for easier power analyzer measurements. The user just mentally moves the voltage and power display decimal points to the right the appropriate number of places. Of course, non-decade ratios may also be used. If the power analyzer is remotely controlled via the IEEE interface, the controller can apply the PT ratio to the measurements automatically. The maximum voltage rating of the PT should be selected 1½ times the expected voltage level to allow for high crest factor waveforms.

The ratio accuracy of PT's is usually about 2%. This is quite a bit wider than the accuracy of a digital power analyzer. The easiest way to improve the accuracy is to measure the actual ratio and use this value when correcting measurements. PT's are low frequency devices, typically 50-400Hz. At high frequencies, their phase shift will cause the power measurement to be in error. Figure 2 illustrates the method of connecting a PT to a digital power analyzer. Other methods are shown in Section 6.

### 102-4. Using Both CT's and PT's

Most applications using PT's will also use CT's as well. In this case, the power measurement must be multiplied by both the CT and PT ratios. Figure 3 illustrates a method of connecting a CT and PT to a digital power analyzer. Section 6 contains other variations on this method.

### 102-5. Poly-Phase Systems

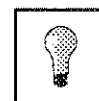
When measuring poly-phase systems, multiple CT's and/or PT's are required. When calculating total power, the individual phase powers should be scaled by the CT/PT ratios and then summed as shown below:

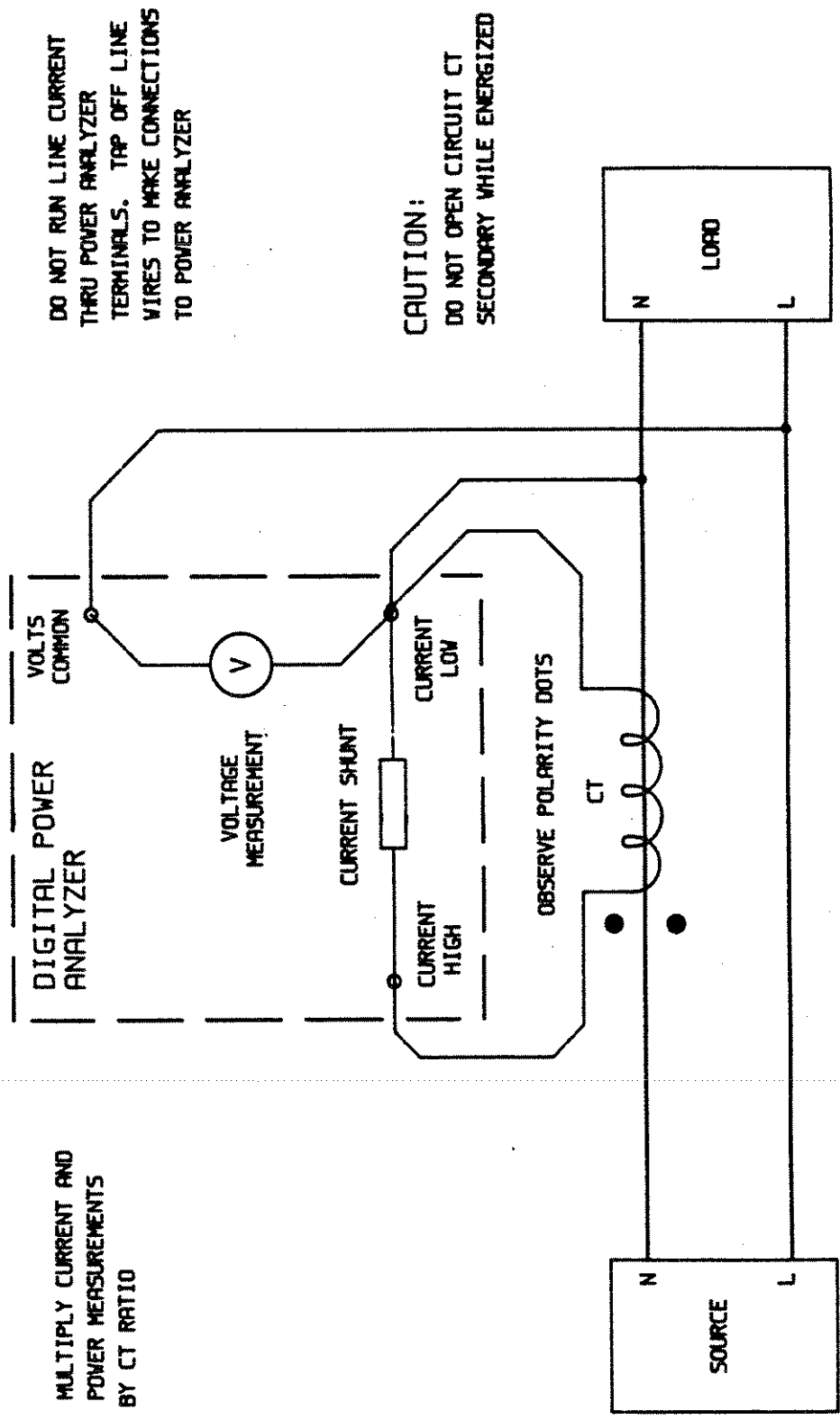
Total Power =

$$(W_a \times PT_a \times CT_a) + (W_b \times PT_b \times CT_b) + (W_c \times PT_c \times CT_c) + \dots + (W_n \times PT_n \times CT_n)$$

Where:

$$\begin{aligned} W_n &= \text{Phase n watts} \\ PT_n &= \text{Phase n PT ratio} \\ CT_n &= \text{Phase n CT ratio} \end{aligned}$$





DO NOT RUN LINE CURRENT THRU POWER ANALYZER TERMINALS. TAP OFF LINE WIRES TO MAKE CONNECTIONS TO POWER ANALYZER

CAUTION: DO NOT OPEN CIRCUIT CT SECONDARY WHILE ENERGIZED

MULTIPLY CURRENT AND POWER MEASUREMENTS BY CT RATIO

FIGURE 1 CURRENT TRANSFORMER CONNECTIONS





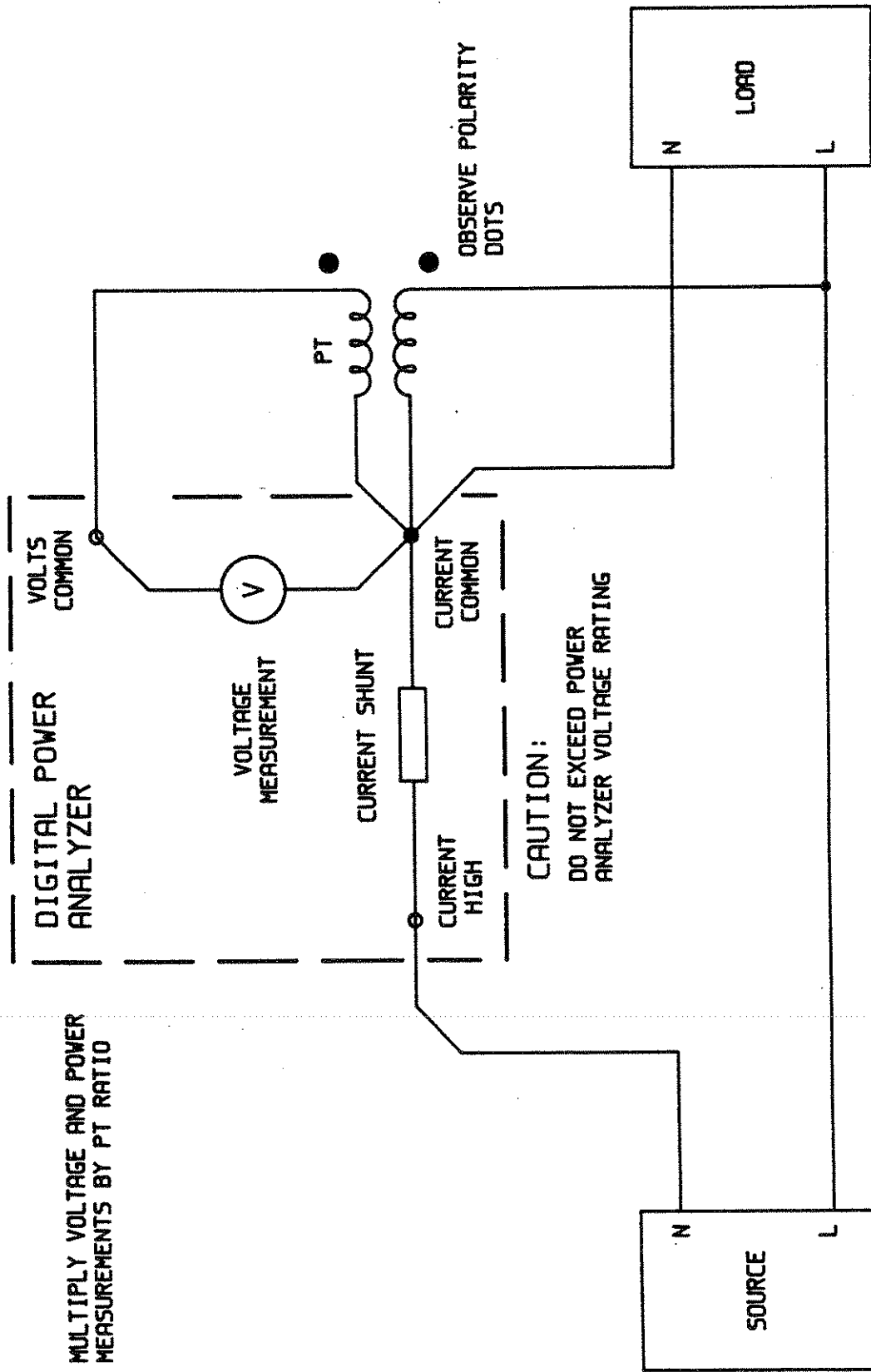


FIGURE 2 POTENTIAL TRANSFORMER CONNECTIONS

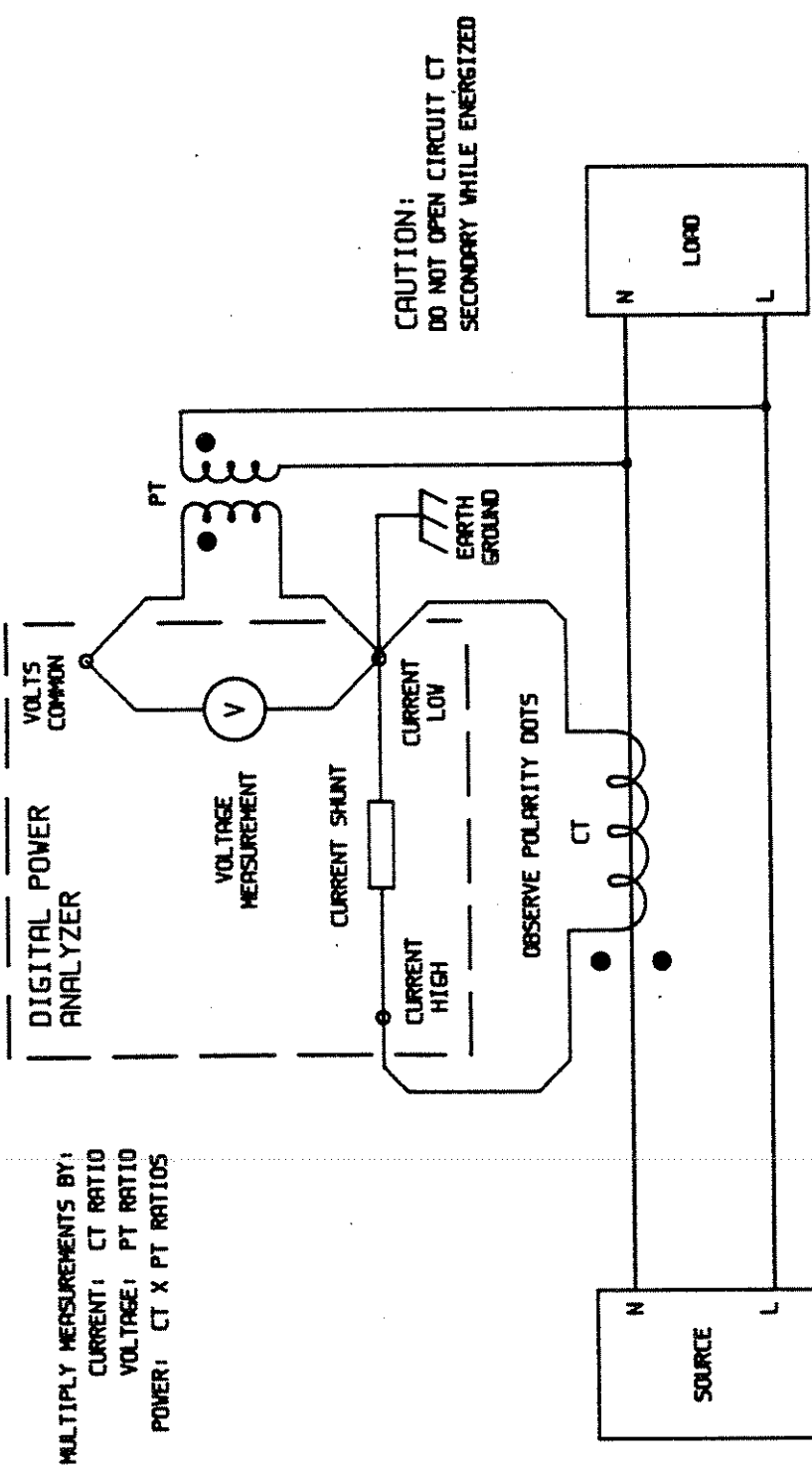


FIGURE 3 CURRENT TRANSFORMER / POTENTIAL TRANSFORMER CONNECTIONS





---

## APPLICATION NOTE AN103

### SOURCE POWER MEASUREMENTS WITH THE 2300

---

#### 103-1. General

The 2300 is ideally suited for measuring the power supplied by a source, e.g. a battery, generator or alternator. The standard method of connecting the 2300 is for measuring the power drawn by a load rather than the power supplied by a source. The difference in these measurements can be quite significant. A look at how the 2300 measures power will aid the user in measuring source power.

#### 103-2. Power Measurement

The 2300 determines power by measuring the voltage across the load, the current through the load and the phase difference between them. The 2300 multiplies these measurements to obtain power.

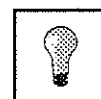
Figure 1 details the standard load power connections. Note that the power measured is not the power supplied by the source. Several watts may be dissipated by the current shunt which is not measured by the 2300.

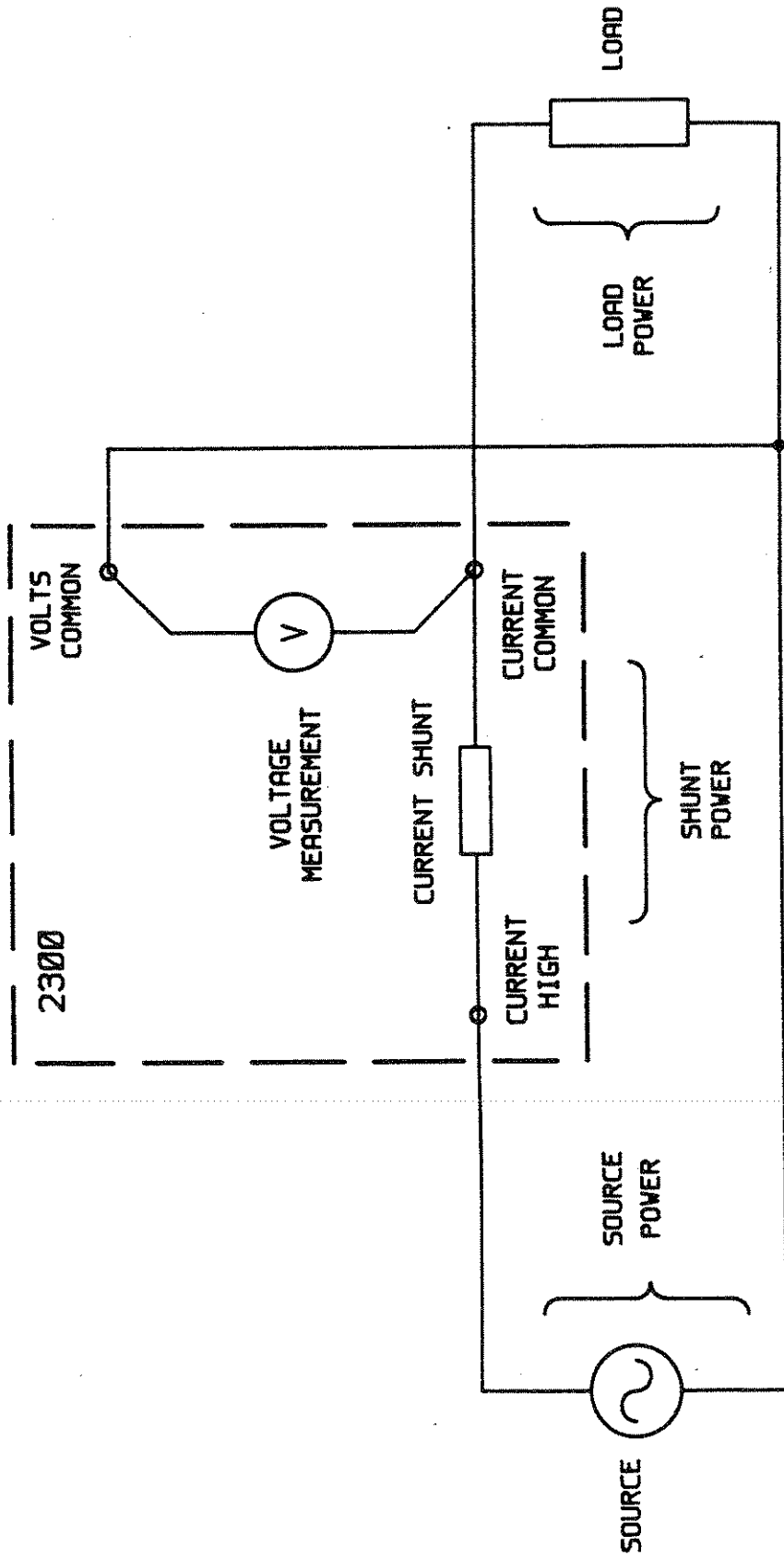
Figure 2 details the connections for measuring source power. The 2300 measures the total of the power dissipated by the load and current shunt. The only other source of inaccuracy is the power dissipated in the connecting leads. Figure 3 details these error sources. The effect of lead resistance can be reduced by connecting the 2300 as shown in Figure 4 and by using heavy gauge wires and ensuring tight connections.

#### 103-3. Summary

The preceding paragraph described the techniques for measuring the power supplied by a source. The examples shown used single-phase connections for clarity. The same techniques can be used for poly-phase systems as well. Three-phase variations on this drawing may be found in Section 6. When making source power measurements, the power measurement should be multiplied by minus one (-1) to obtain the correct watts polarity. The following checklist will aid the user in obtaining accurate source power measurements:

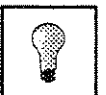
1. Connect the 2300 to the source and load as shown in Figure 4.
2. Use short, heavy gauge wire between the source and the current common terminal.
3. Tighten all connections.
4. Multiply the power reading by minus one (-1).

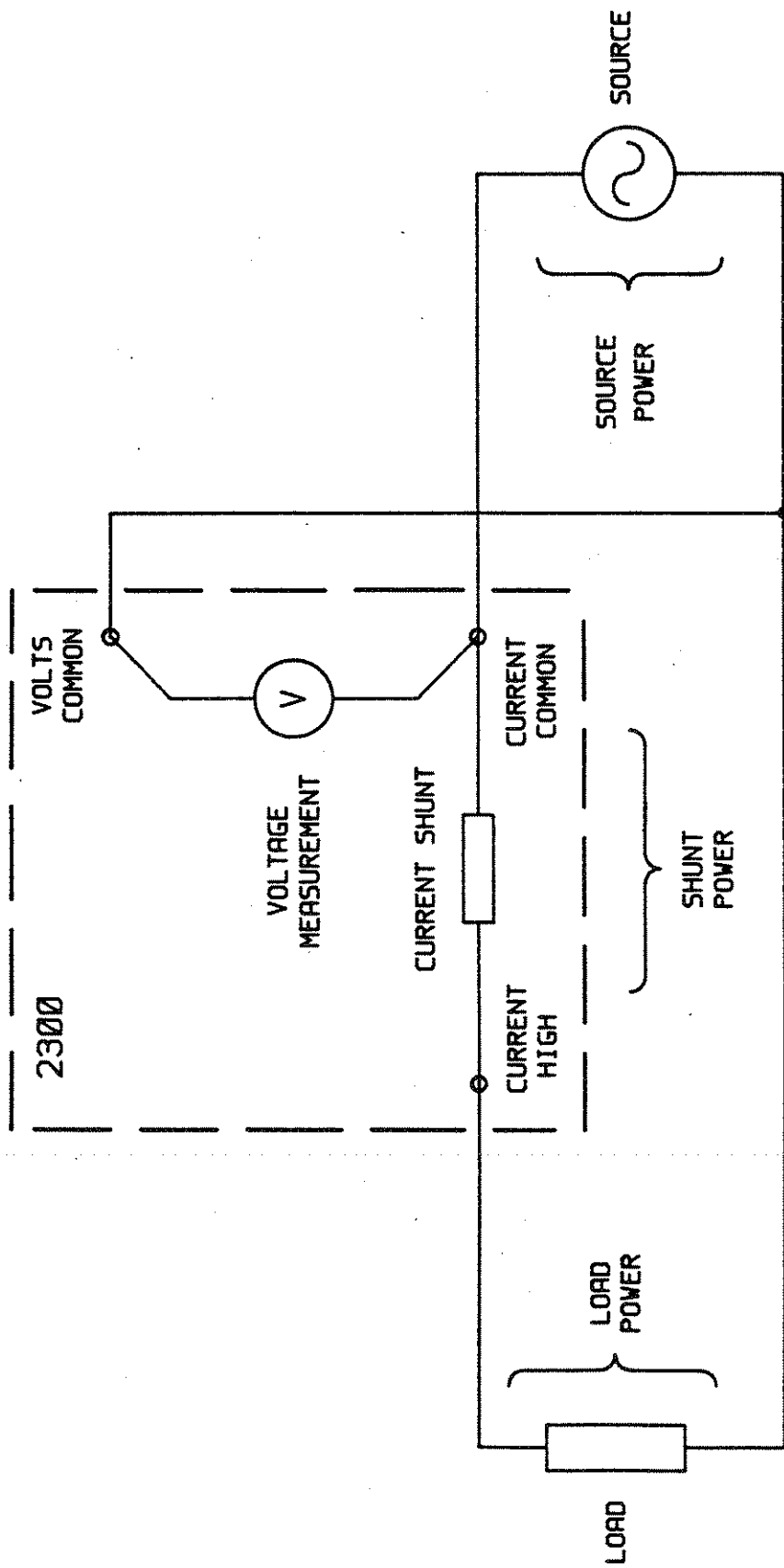




SOURCE POWER = LOAD POWER + SHUNT POWER  
 2300 MEASURES POWER IN LOAD ONLY

FIGURE 1 LOAD POWER CONNECTIONS

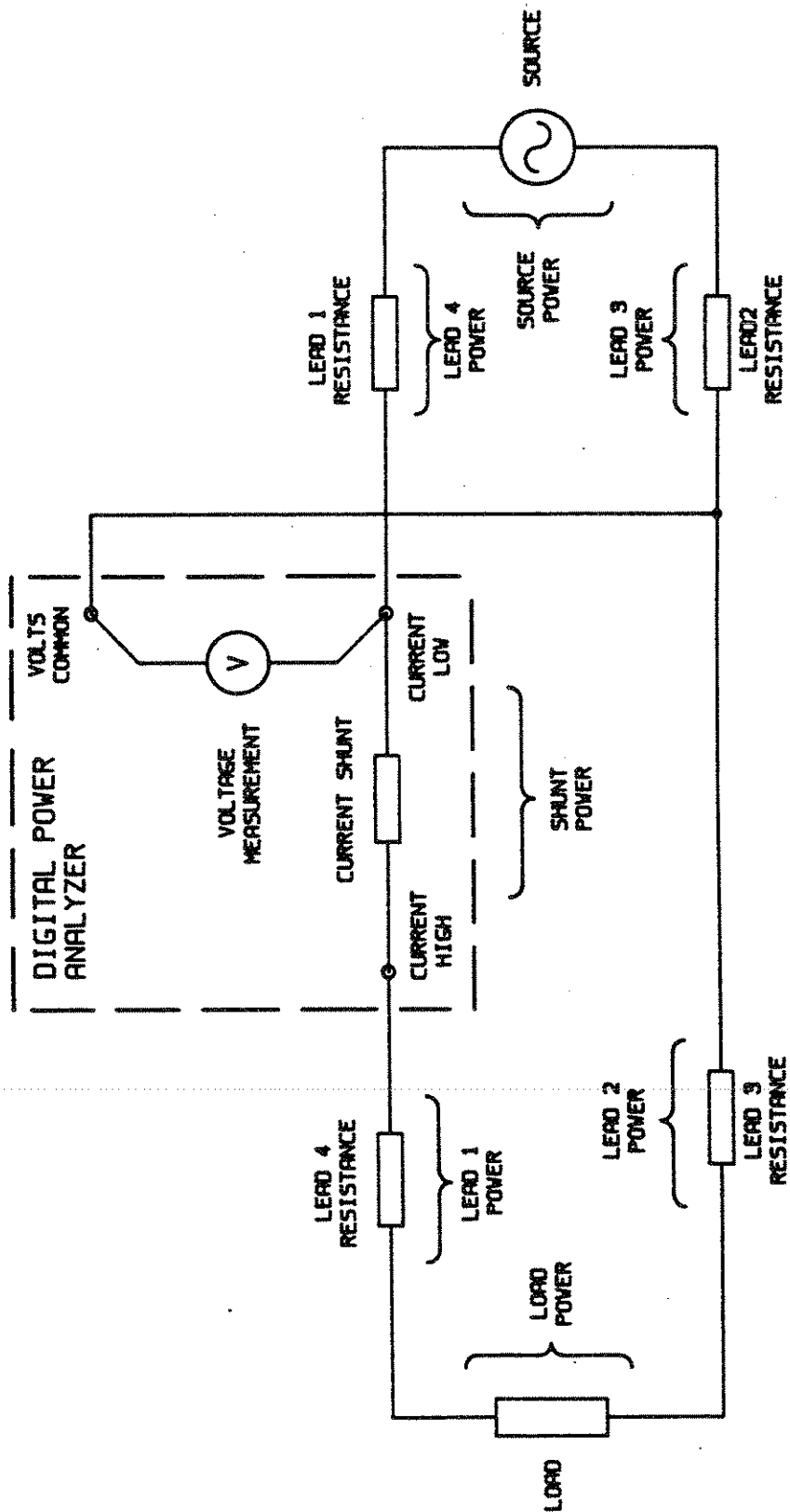




SOURCE POWER = LOAD POWER + SHUNT POWER  
 2300 MEASURES POWER SUPPLIED BY SOURCE

FIGURE 2 SOURCE POWER CONNECTIONS



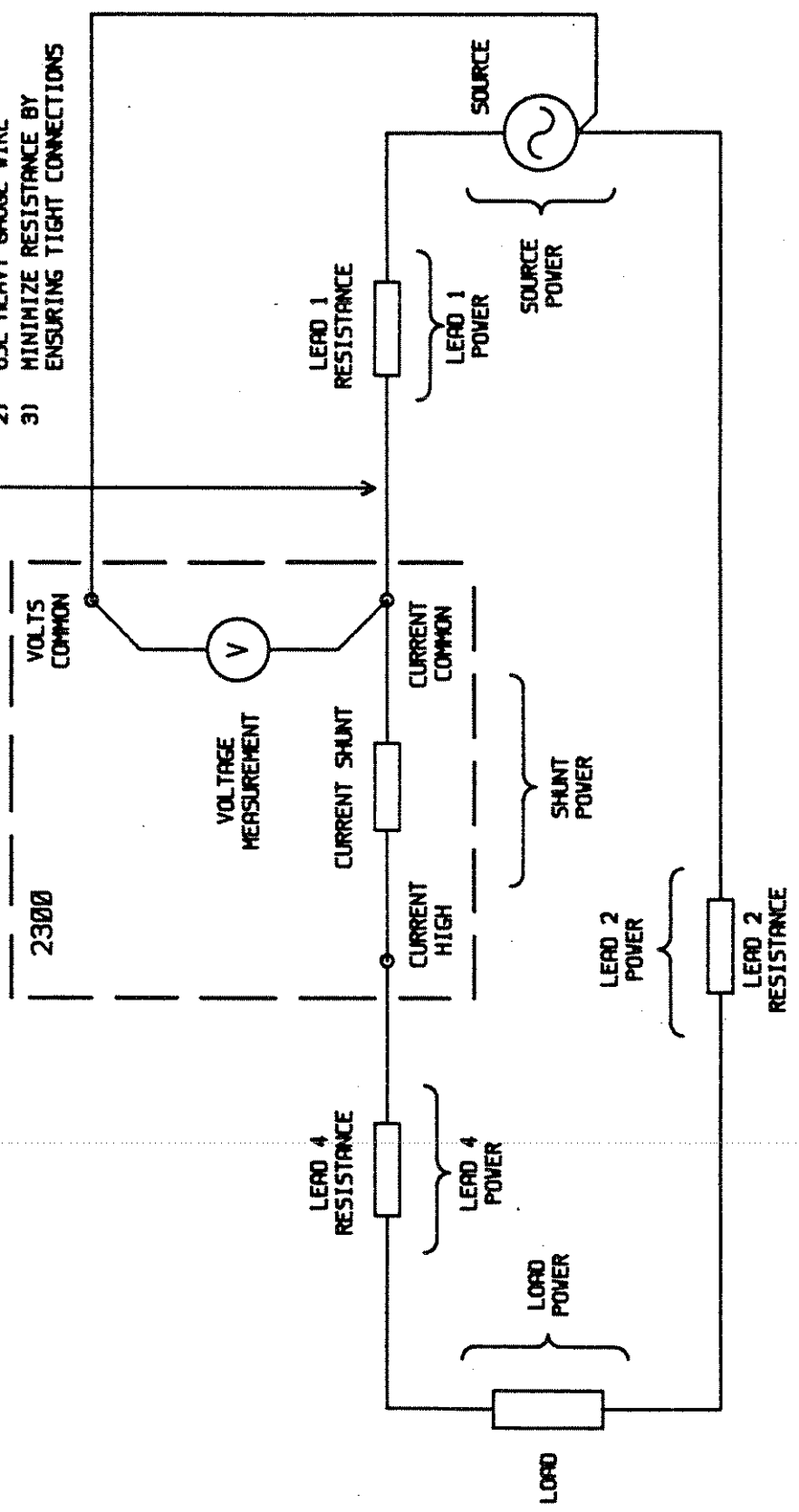


$SOURCE\ POWER = LOAD\ POWER + SHUNT\ POWER + LEAD\ 1 - 4\ POWERS$   
 $2300B\ MEASURES\ LOAD\ POWER + SHUNT\ POWER + LEAD\ 3\ POWER + LEAD\ 4\ POWER$   
 $MEASUREMENT\ ERROR = LEAD\ 1\ POWER + LEAD\ 2\ POWER$

**FIGURE 3 LEAD RESISTANCE ERROR SOURCES**



- NOTE:**
- 1) KEEP LEAD SHORT
  - 2) USE HEAVY GAUGE WIRE
  - 3) MINIMIZE RESISTANCE BY ENSURING TIGHT CONNECTIONS



SOURCE POWER = LOAD POWER + SHUNT POWER + LEAD 1 - 4 POWERS  
 2300 MEASURES LOAD POWER + SHUNT POWER + LEAD 2 - 4 POWER  
 MEASUREMENT ERROR = LEAD 1 POWER

FIGURE 4 MINIMIZING ERROR SOURCES





---

**APPLICATION NOTE AN104**  
**MEASURING PHASE CURRENTS IN 3-WIRE SYSTEMS**  
**WITH THE 2300**

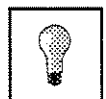
---

**104-1. General**

The 2300 is ideally suited for measuring the power in a 3-phase 3-wire connected load. Some test procedures require that the individual phase currents be measured and recorded. The standard 3-phase 3-wire connections allow for displaying the phase A and phase C currents directly. The phase B current is usually measured with an external ammeter. The 2300 can easily be reconnected to measure the phase B current as well.

**104-2. Connections**

The standard 3-phase 3-wire connections are shown in Figure 1. In it, the 2300 uses the two wattmeter method of measuring 3-phase 3-wire power. The channel B wattmeter is not used. The channel B wattmeter can easily be connected to measure the phase B current as shown in Figure 2. The phase currents can be displayed by pressing the  $\phi A$ ,  $\phi B$  and  $\phi C$  display selection push-buttons. The total power is displayed by pressing the  $3\phi$  3-wire display selection push-button.



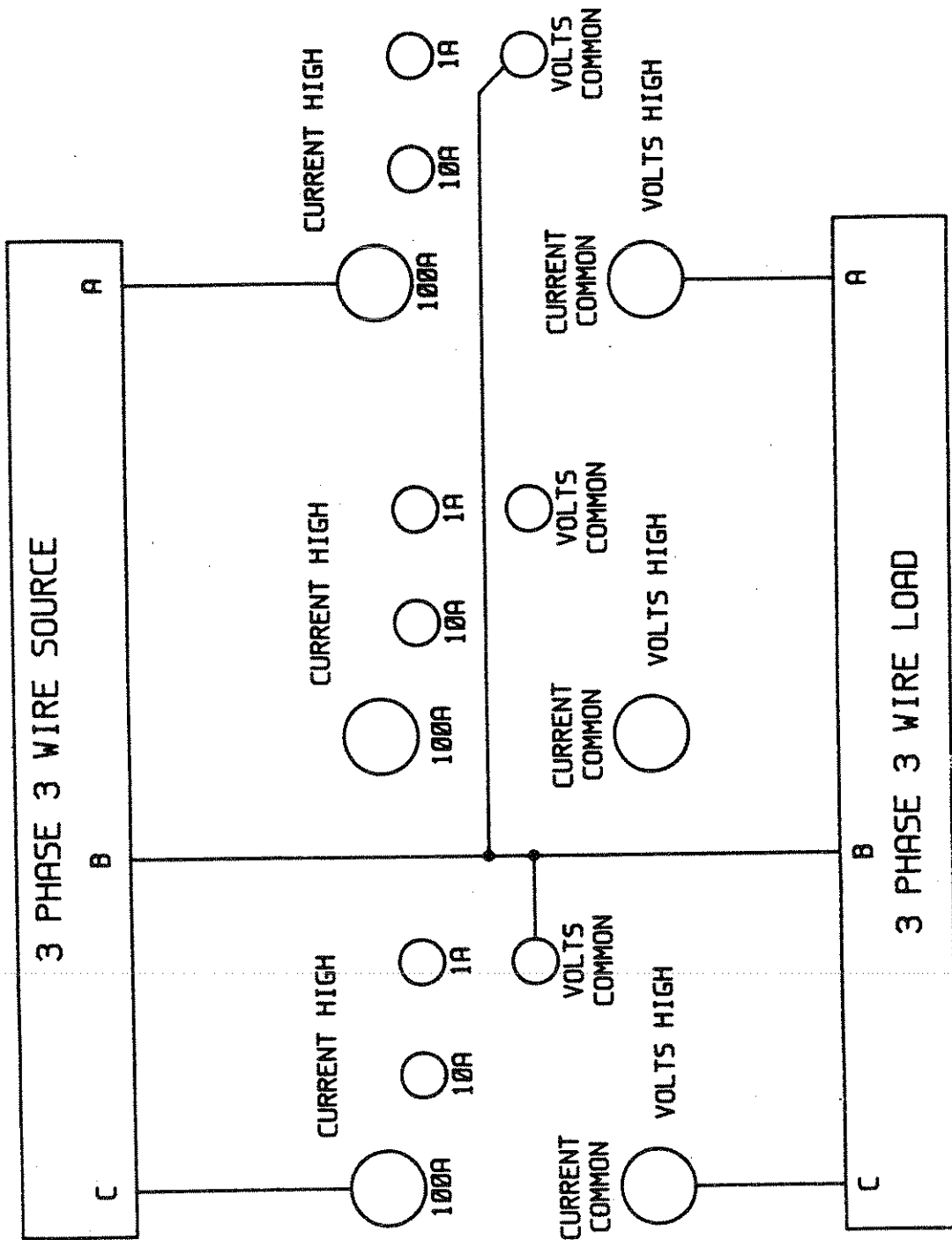


FIGURE 1 3 PHASE 3 WIRE STANDARD CONNECTIONS



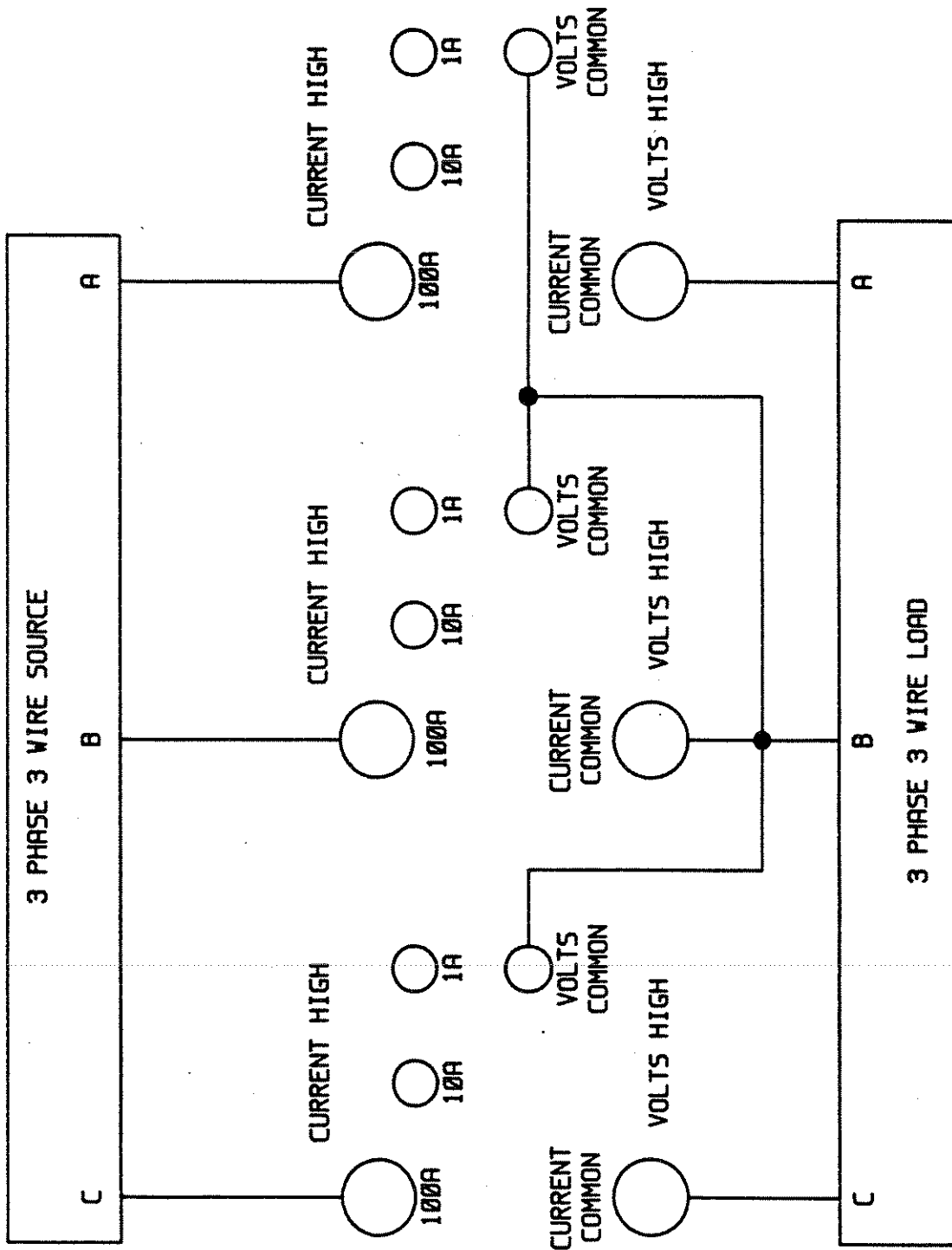


FIGURE 2 ALTERNATE 3 PHASE 3 WIRE CONNECTIONS



---

**APPLICATION NOTE AN105  
MEASURING TRANSFORMER LOSS  
WITH THE 2300**

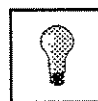
---

**105-1. General**

The 2300 is ideally suited for measuring the loss of single phase transformers. The following paragraph describes the connections required to display transformer loss on the 2300.

**105-2. Connections**

Figure 1 details the connections to the 2300. Channel A of the 2300 is connected to measure the input power drawn by the transformer. Channel C measures the power sourced by the transformer secondary. When the 2300 is connected for source power measurement, the power display has a negative polarity. The 3 $\phi$  3-Wire display sums the power measurements of channels A and C. The result is the difference between the power drawn by the transformer and the power sourced by the transformer. This difference is the "loss" or the amount of power dissipated by the transformer.



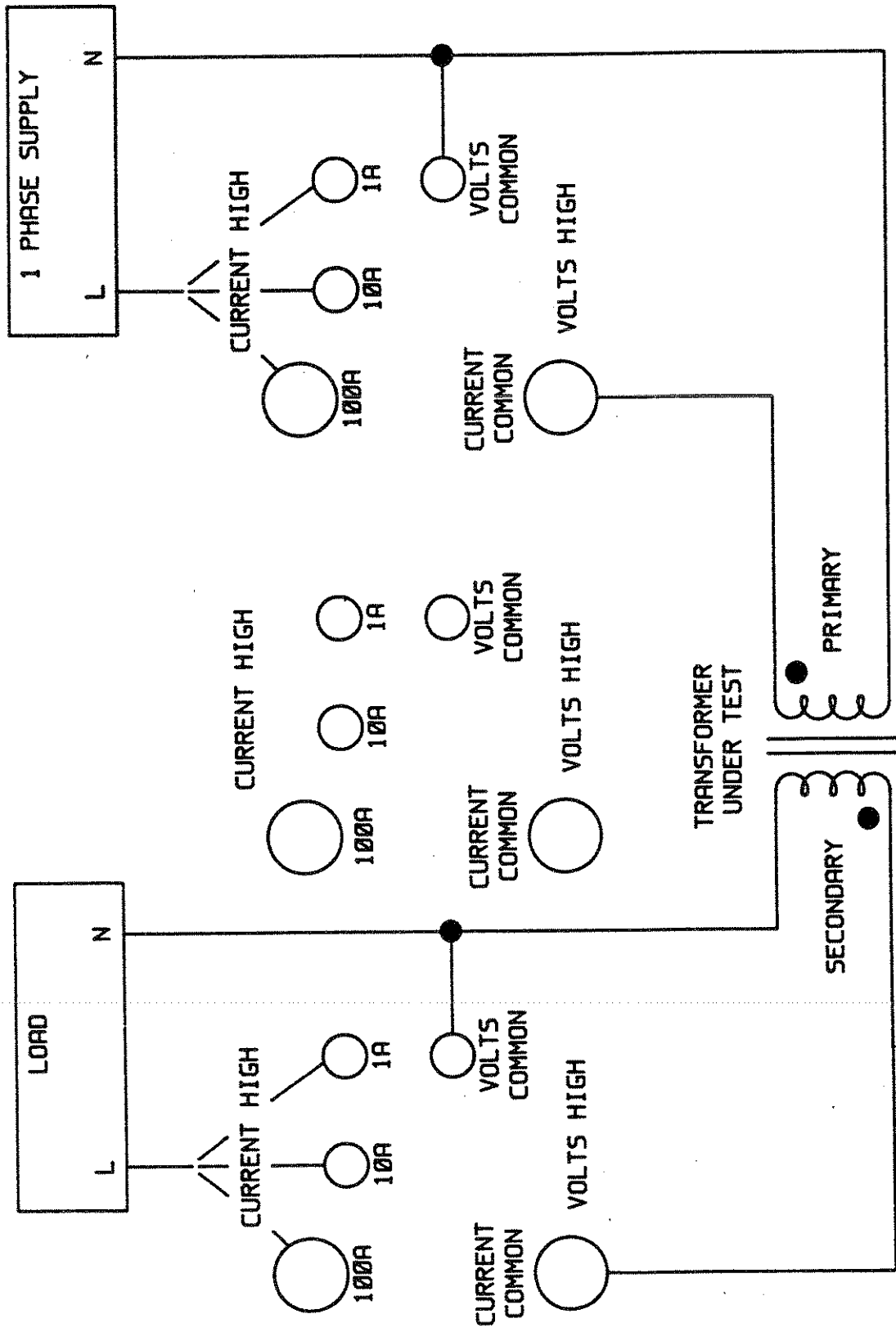


FIGURE 1 TRANSFORMER LOSS CONNECTIONS

FIGURE 1



---

**APPLICATION NOTE AN106**  
**MEASURING POWER FACTOR AND REACTIVE VOLT-AMPERES WITH**  
**VALHALLA SCIENTIFIC DIGITAL POWER ANALYZERS**

---

### **106-1. General**

Valhalla Scientific digital power analyzers directly measure the voltage, current and power drawn by single and poly-phase loads. Volt-Amperes (VA), Reactive Volt-Amperes (VAR) and power factor (PF) are not displayed but can easily be calculated from the voltage, current and power measurements. The displays of the 2300 may be frozen using the recently added RUN/HOLD feature to make calculations easier. The following paragraphs describe the methods for calculating VA's, VAR's and PF.

### **106-2. VA's, Watts, VAR's and PF**

The relationships between VA's, Watts, VAR's and PF can best be described in a graphical manner. Figure 1 illustrates these relationships. VA's are calculated by multiplying the true RMS voltage and true RMS current measurements of the digital power analyzer. Power factor is the cosine of the angle between VA's and Watts and can be calculated using basic trigonometry. Reactive power, VAR's, is calculated from VA's and Watts using Pythagorean's theorem.

### **106-3. PF, Leading or Lagging?**

The terms leading and lagging power factor refer to the relative phase shift between the current and voltage waveforms. The current leads the voltage in a capacitive load while the current lags the voltage in an inductive load. When calculating power factor using present Valhalla Scientific digital power analyzers

other than the models 2110A/2111A which display it directly, there is no way of determining whether the power factor is leading or lagging. An oscilloscope must be used to determine leading or lagging. Fortunately, most every load has a lagging power factor. If the load has a transformer, fan, or motor, it is safe to assume lagging power factors and an oscilloscope is not required.

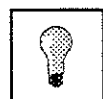
### **106-4. Single-Phase Systems**

Determining VA's, VAR's and PF in single-phase systems is straightforward. Connect the digital power analyzer to the load and record the voltage, current and power. Calculate VA's, VAR's and PF as shown in Figure 1.

### **106-5. Poly-Phase Systems**

Determining VA's, VAR's and PF in poly-phase systems is a little more involved than for single-phase systems. The discussion below is for three-phase systems, however the same ideas can be expanded for any poly-phase system.

To determine three-phase VA's and PF, the individual phase VAR's must first be calculated. Referring to Figure 1, it can be seen that VA's do not add up unless the individual power factors are identical. VAR's and Watts can be algebraically summed to obtain three-phase Watts and VAR's. Three-phase VA's and PF are then calculated from three-phase Watts and VAR's.



### 106-5-1. 3-Phase 4-Wire VA's, VAR's and PF

To determine VA's, VAR's and PF for 3-phase 4-wire connected loads, the following procedure is recommended. Refer to Figure 1:

- 1) Connect the 2300 to the load as described in Section 6.
- 2) Measure and record the voltage, current, and power for each phase.
- 3) Calculate  $\phi A$  VA's and VAR's.
- 4) Calculate  $\phi B$  VA's and VAR's.
- 5) Calculate  $\phi C$  VA's and VAR's.
- 6) Add  $\phi A$ ,  $\phi B$  and  $\phi C$  VAR's to obtain 3-phase VAR's.
- 7) Add  $\phi A$ ,  $\phi B$  and  $\phi C$  watts to obtain 3-phase watts.
- 8) Calculate 3-phase VA's from 3-phase VAR's and watts.
- 9) Calculate 3-phase PF from 3-phase VA's and watts.

When calculating 3-phase VAR's, it is safe to assume that the individual phase power factors are all lagging if the load has a transformer or motor. An oscilloscope or Valhalla Model 2110A/2111A may be used if there is any doubt.

### 106-5-2. 3-Phase 3-Wire VA's, VAR's and PF

To determine VA's, VAR's and PF in 3-phase 3-wire connected loads the following procedure is recommended. Refer to Figure 1.

- 1) Connect the 2300 to the load as described in Section 6.
- 2) Measure and record the voltage, current and power for  $\phi A$  and  $\phi C$ .
- 3) Calculate  $\phi A$  VA's and VAR's.
- 4) Calculate  $\phi C$  VA's and VAR's.
- 5) Add  $\phi A$  and  $\phi C$  VAR's to obtain 3-phase VAR's.
- 6) Add  $\phi A$  and  $\phi C$  watts to obtain 3-phase watts.

7) Calculate 3-phase VA's from 3-phase VAR's and watts.

8) Calculate 3-phase PF from 3-phase VA's and watts.

When calculating 3-phase VAR's it is safe to assume that the individual phase power factors are all lagging if the load has a transformer or motor. An oscilloscope or Valhalla Model 2110A/2111A may be used if there is any doubt.

### 106-6. PF and VAR Accuracies

The accuracies of the PF and VAR calculations are the sums of the accuracies of the voltage, current and power measurements. For the 2300, the accuracies are as shown below:

#### SINGLE PHASE

$$\begin{aligned} &\pm (0.1\% \text{ V rdg} + 0.1\% \text{ V rng}) \\ &\pm (0.25\% \text{ A rdg} + 0.25\% \text{ A rng}) \\ &\pm (0.25\% \text{ W rdg} + 0.25\% \text{ W rng}) \end{aligned}$$

#### 3-PHASE 3-WIRE

$$\begin{aligned} &\pm (0.1\% \text{ V}_a \text{ rdg} + 0.1\% \text{ V}_c \text{ rdg} + 0.2\% \text{ V rng}) \\ &\pm (0.25\% \text{ A}_a \text{ rdg} + 0.25\% \text{ A}_c \text{ rdg} + 0.5\% \text{ A rng}) \\ &\pm (0.25\% \text{ W}_a \text{ rdg} + 0.25\% \text{ W}_c \text{ rdg} + 0.5\% \text{ W rng}) \end{aligned}$$

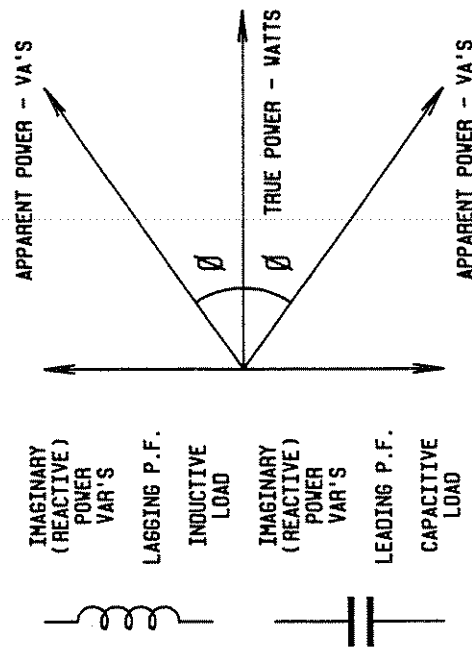
#### 3-PHASE 4-WIRE

$$\pm (0.1\% \text{ V}_a \text{ rdg} + 0.1\% \text{ V}_b \text{ rdg} + 0.1\% \text{ V}_c \text{ rdg} + 0.3\% \text{ V rng})$$

$$\pm (0.25\% \text{ A}_a \text{ rdg} + 0.25\% \text{ A}_b \text{ rdg} + 0.25\% \text{ A}_c \text{ rdg} + 0.75\% \text{ A rng})$$

$$\pm (0.25\% \text{ W}_a \text{ rdg} + 0.25\% \text{ W}_b \text{ rdg} + 0.25\% \text{ W}_c \text{ rdg} + 0.75\% \text{ W rng})$$





$$PF = \cos \phi = \frac{W}{VA} \cdot \text{LAGGING}$$

$$PF = \cos \phi = \frac{W}{VA} \cdot \text{LEADING}$$

VA'S = TRMS VOLTS X TRMS AMPS

$$VAR'S = \sqrt{VA'S^2 - W'S^2}$$

$$VA'S = \sqrt{VAR'S^2 + W'S^2}$$

$$W'S = \sqrt{VA'S^2 - VAR'S^2}$$

FIGURE 1 WATTS, VA'S, VAR,S AND PF





---

**APPLICATION NOTE AN107**  
**MINIMIZING ERROR SOURCES IN THREE-WIRE CONNECTED**  
**DIGITAL POWER ANALYZERS**

---

### 107-1. General

This application note describes the sources of measurement error in three-wire type digital power analyzers. Methods for reducing these error sources are also discussed.

### 107-2. 3-Wire Digital Power Analyzers

The term "3-wire digital power analyzer" refers to the number of terminals the analyzer uses to connect to the load under test. Referring to Figure 1, the power analyzer measures the current flowing through the current shunt and the voltage between the current shunt and voltage common terminal. The voltage measurement and current measurement sections of the analyzer share a common terminal.

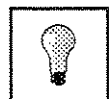
### 107-3. Error Sources

Measurement errors arise in three-wire type digital power analyzers due to connecting lead resistances. A power analyzer hook-up showing error sources is shown in Figure 2. The contact and lead resistances are combined and shown as "R LEAD x", with the x denoting the individual lead. Lead resistances 1 and 2 do not contribute any error other than lowering the effective source voltage. Lead resistances 3 and 4 are sources of error. The power analyzer measures the voltage drop across the load plus the lead resistances. The power measurement will be in error by the sum of the lead ( $I^2R$ ) powers.

### 107-4. Error Reduction

The errors caused by the lead resistances can be reduced by a factor of 2 by simply reconnecting the voltage common terminal of the power analyzer as shown in Figure 3. The effect of "R LEAD 3" is eliminated. The effect of "R LEAD 4" can be reduced by using a short heavy gauge wire and ensuring tight connections. In applications where it is impractical to shorten lead 4, an alternate technique is discussed below.

A measurement is first made using the connections of Figure 3. The connections are then changed to those of Figure 4. This connection measures the power in lead 4. This power is then subtracted from the first measurement yielding an accurate representation of the power in the load only.



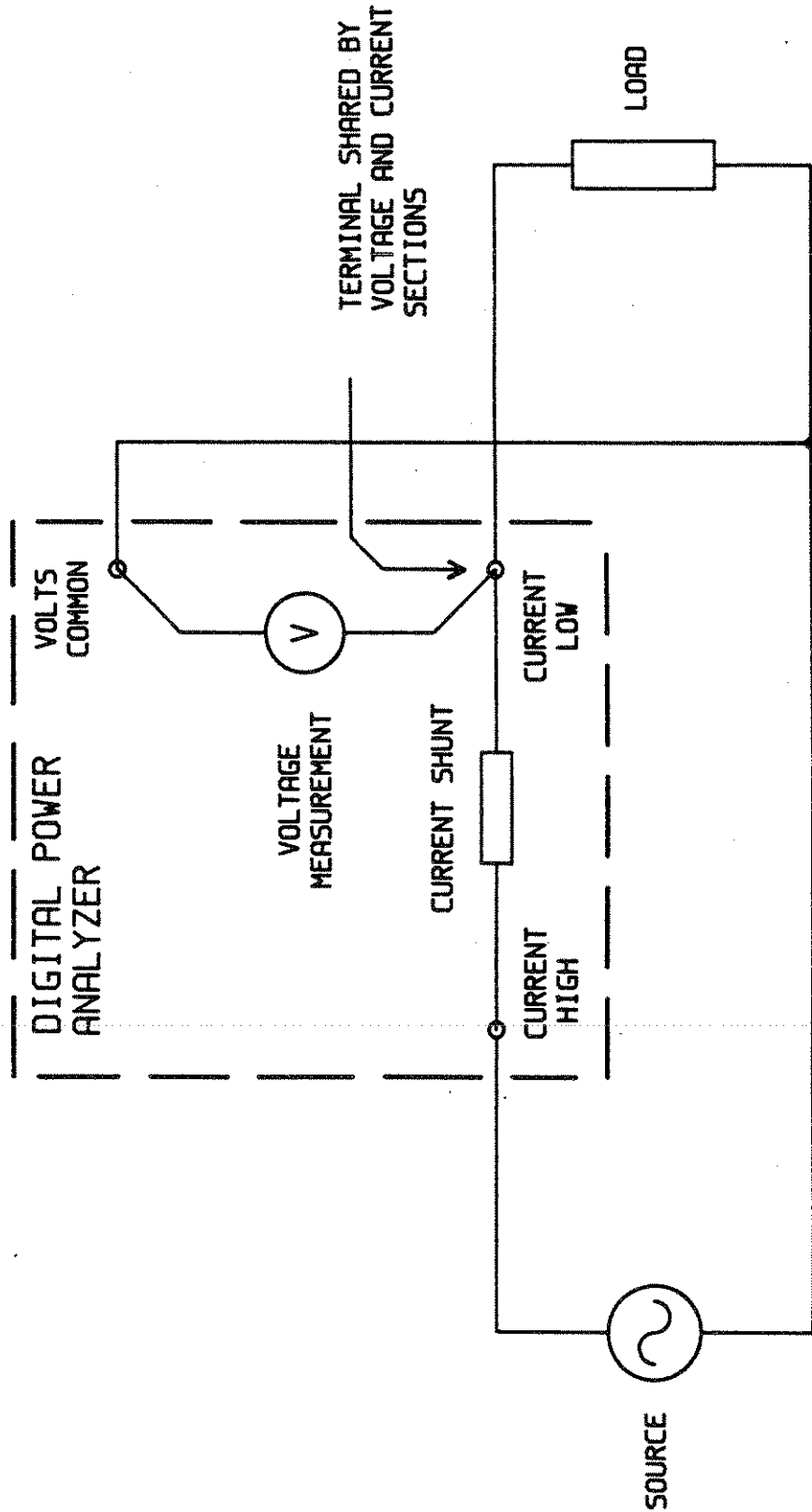


FIGURE 1 THREE WIRE TYPE DIGITAL POWER ANALYZER



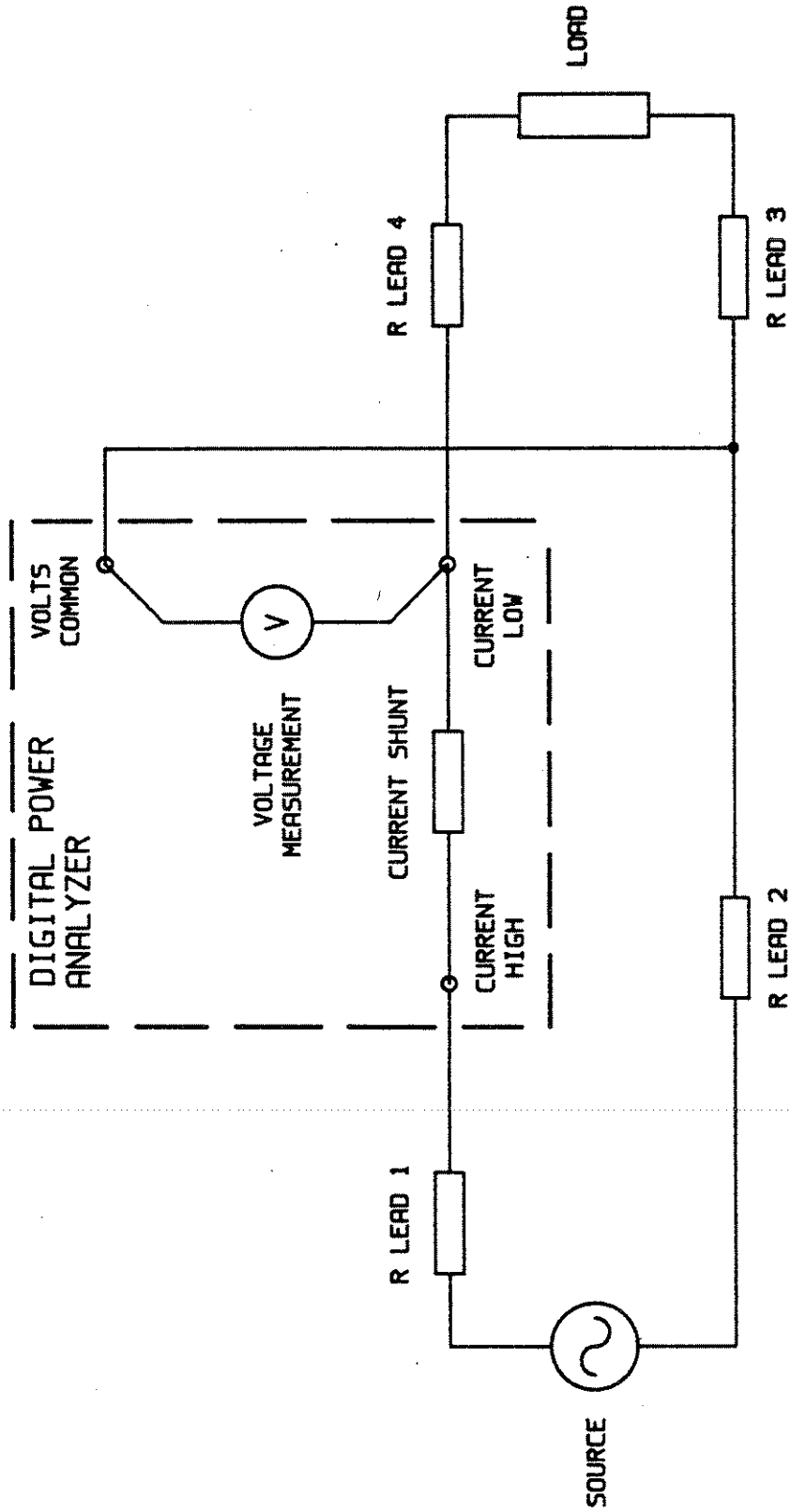
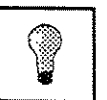


FIGURE 2 DIGITAL POWER ANALYZER · ERROR SOURCES



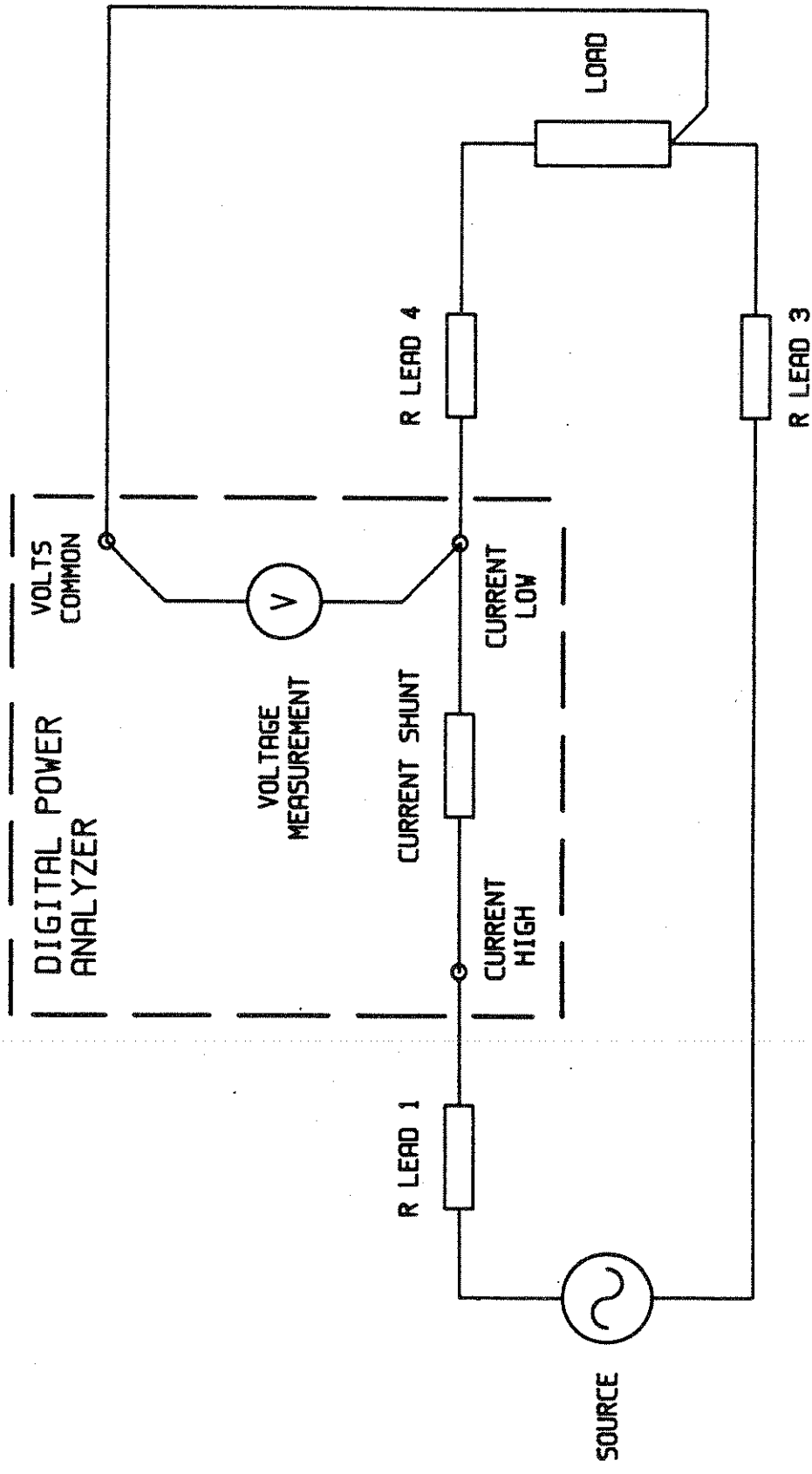
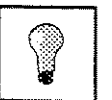


FIGURE 3 ERROR SOURCE REDUCTION



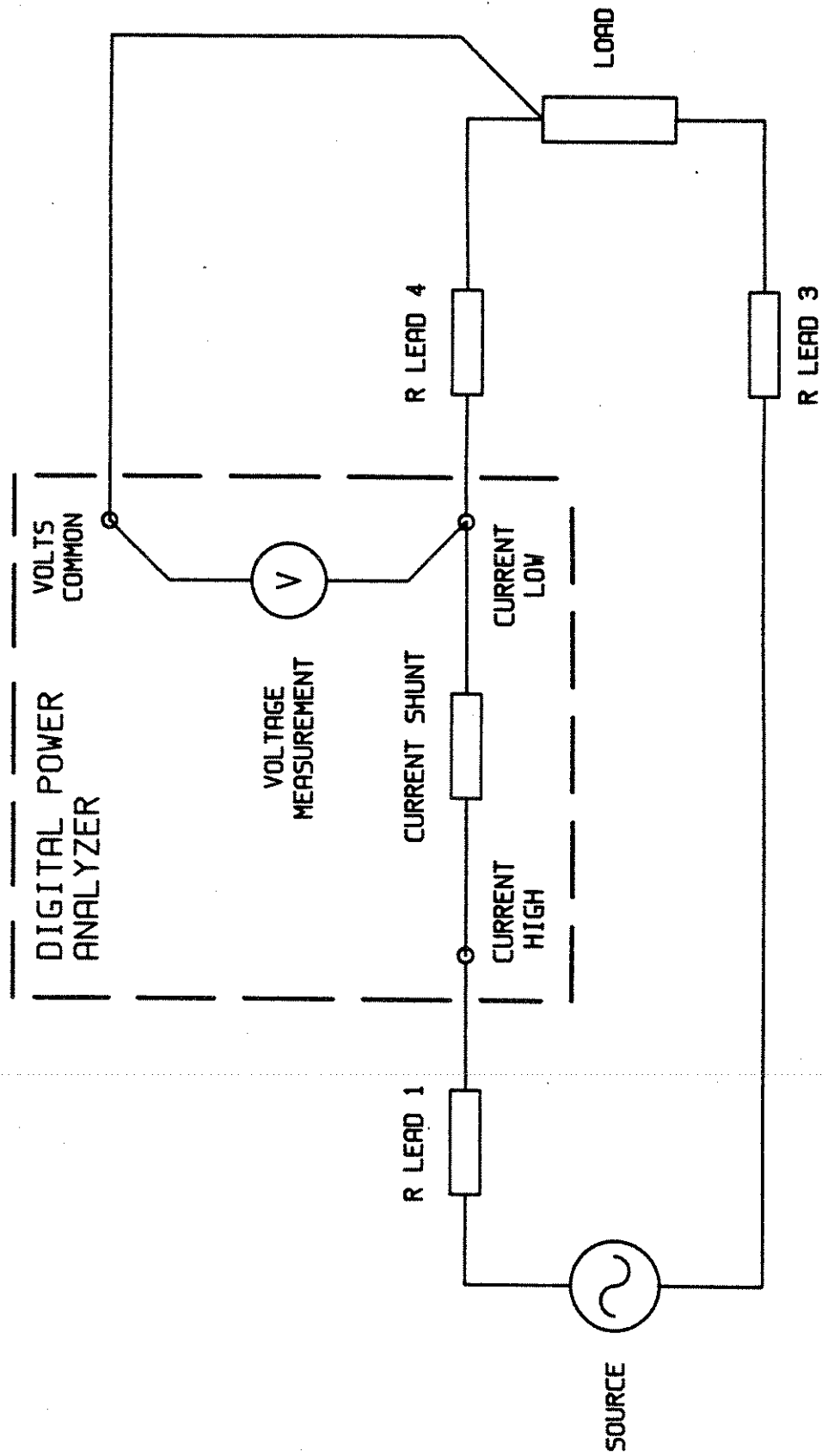
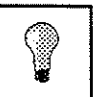


FIGURE 4 MEASURING POWER LOSS IN CONNECTING LEADS



---

**APPLICATION NOTE AN108**  
**MEASURING SINGLE-PHASE THREE-WIRE POWER**  
**WITH THE 2300**

---

### 108-1. General

This application note describes the connections required to measure a single-phase three-wire connected load with the 2300.

### 108-2. Single-Phase Three-Wire Systems

This system consists of two 120Vrms (nominal) lines and a common grounded neutral conductor. The two 120Vrms lines are phase shifted 180 degrees. This system is sometimes called "splitphase 120/240V". 120Vrms is measured between either line and neutral, and 240Vrms line to line. Figure 1 details the line voltage relationships.

**Single-phase three-wire power is available in most every residential structure in the United States.** Lighting fixtures and wall outlets are powered from one line and neutral. Major appliances e.g. electric clothes dryers, electric ovens and air-conditioners are commonly powered from 240VAC using single-phase three-wire power.

### 108-3. 2300 Connections

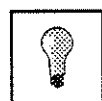
Single-phase three-wire systems may be looked upon as two single-phase power measurements. The total single-phase three-wire power is the sum of the individual phase powers. Figure 2 details the connections to the 2300. Channels A and C are used to measure the individual phase powers. The individual phase powers are displayed by pressing the  $\emptyset A$  and  $\emptyset C$  display selection push-buttons.

The total single-phase three-wire power is displayed by pressing the  $3\emptyset$  3-wire display selection push-button. The voltage and current displays will be blanked in this mode.

### 108-4. Measuring Neutral Current

Some applications require the measurement of neutral current as well as total power and line currents. This is easily accomplished with the 2300. These connections are shown in Figure 3. The neutral current is passed through the  $\emptyset B$  current shunt. The neutral current is displayed by pressing the  $\emptyset B$  display selection push-button.

☛ If this method is used with a Model 2301, only one line may be measured at a time.



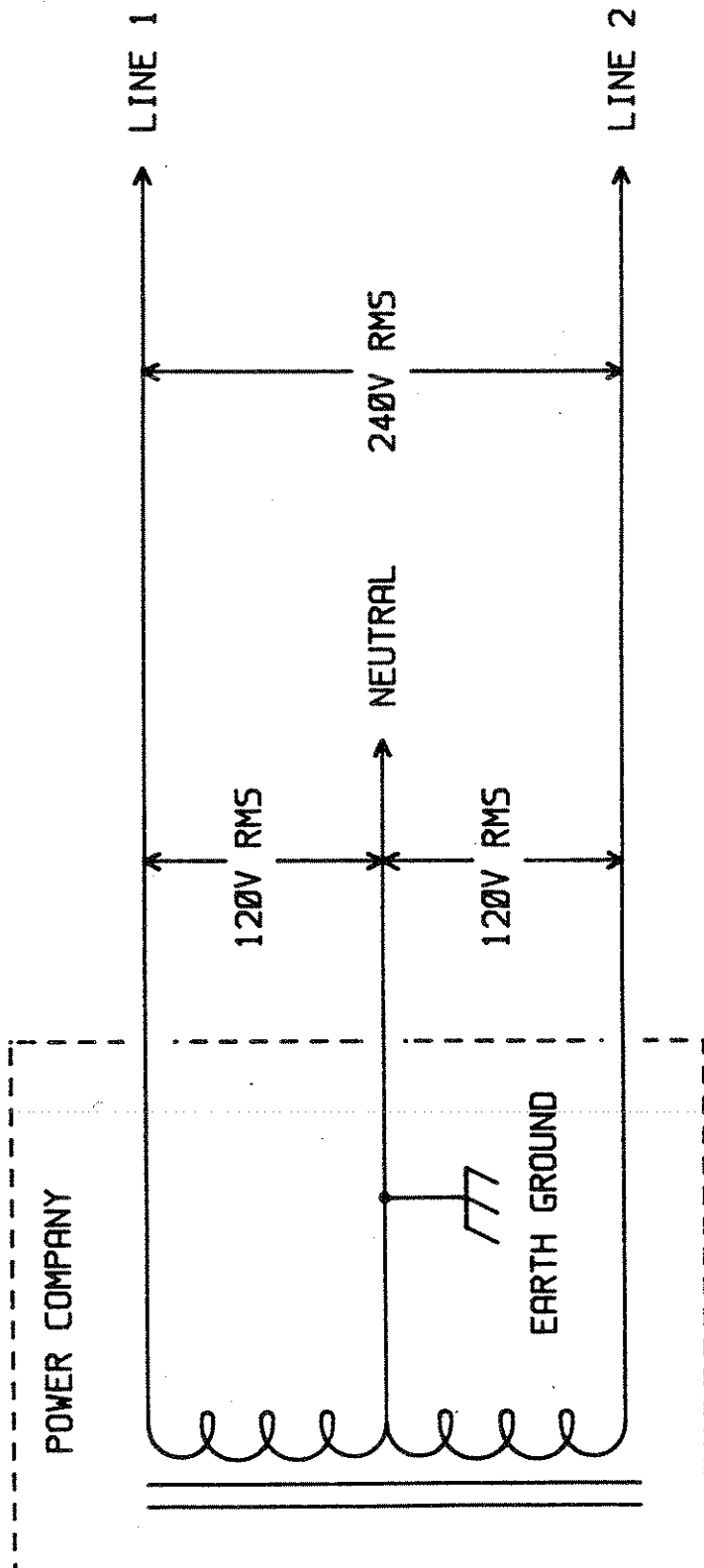


FIGURE 1 SINGLE PHASE THREE WIRE POWER

FIGURE 1



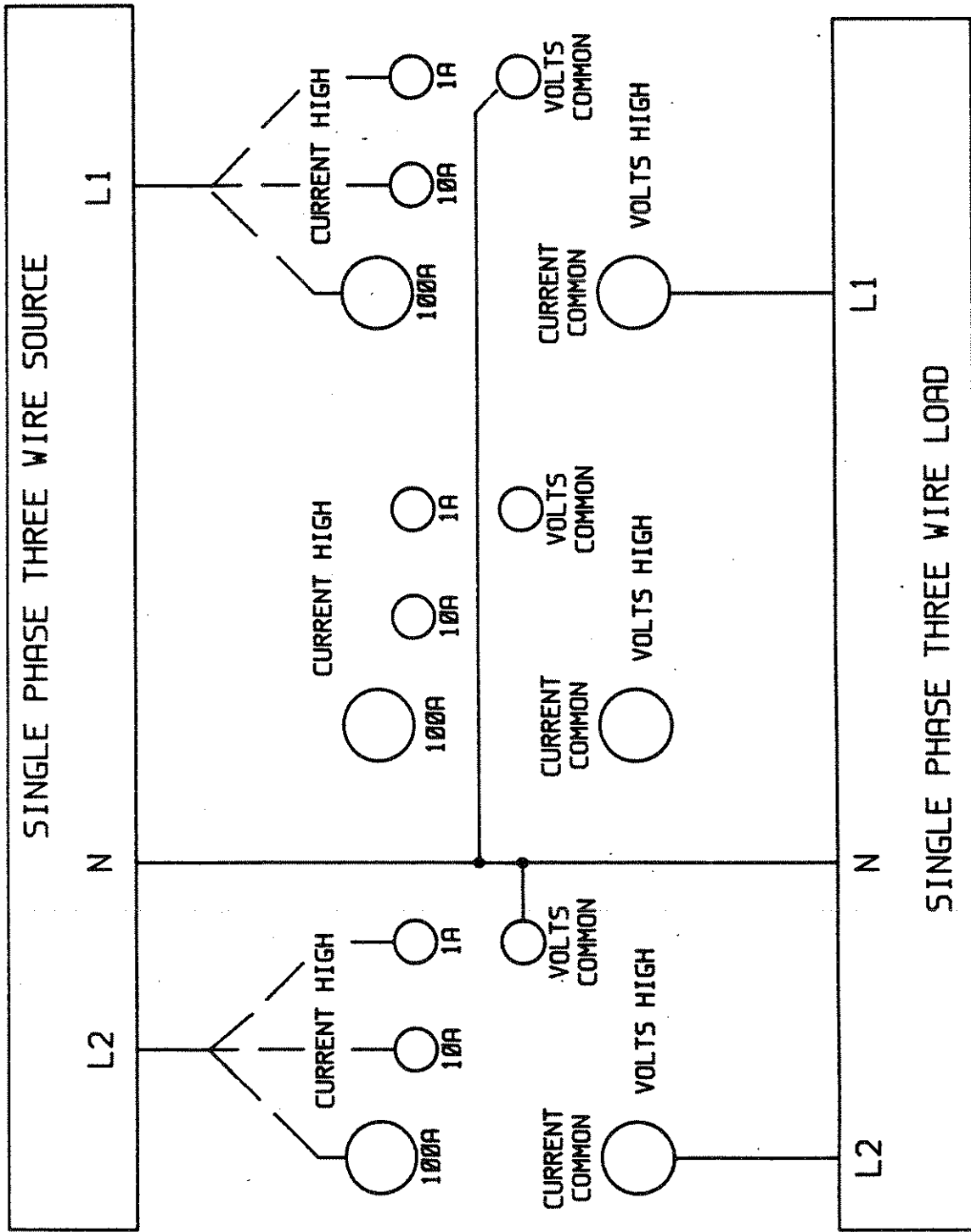
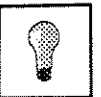


FIGURE 2 SINGLE PHASE THREE WIRE CONNECTIONS





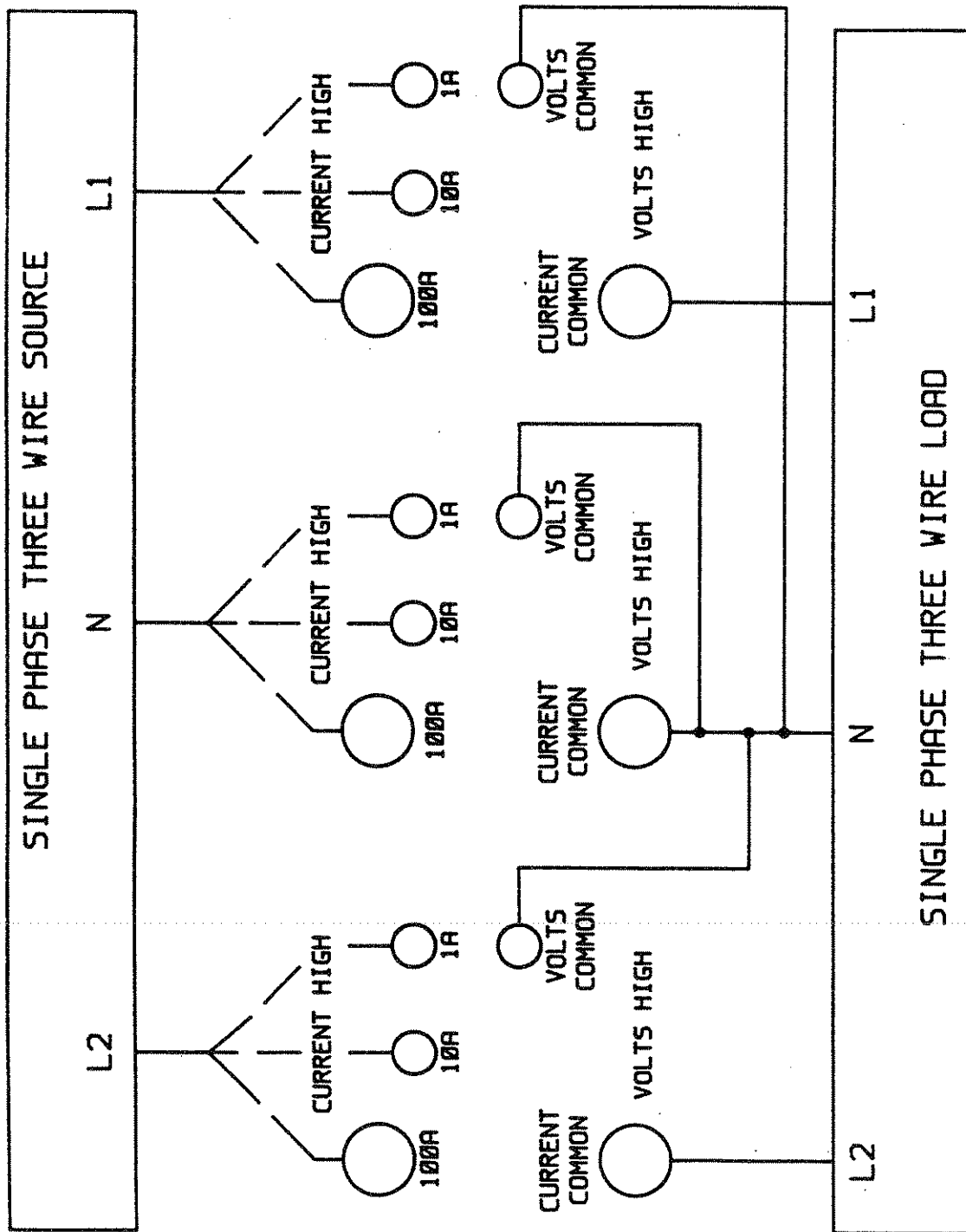
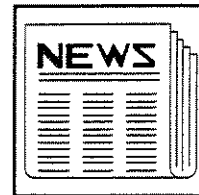


FIGURE 3 ALTERNATE SINGLE PHASE THREE WIRE CONNECTIONS



## SECTION XII MANUAL CHANGES AND ADDENDUMS

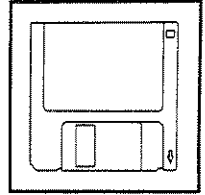
---



If no addendums follow this page your manual is complete as printed.

## SECTION XIII PARTS LISTS

---



The following parts lists have been included in this manual:

2300 Chassis Assembly .....	2300-400
2300/01 Signal Processing PCB .....	2300-600
2300 Main PCB .....	2300-601
2300 Display PCB .....	2300-602
2300L .....	2300-404
2301 Chassis Assembly .....	2301-400
2301 Main PCB .....	2301-601
2301 Display PCB .....	2301-602
2301L .....	2300-401
Option IO3 .....	2300-605
Option IOX .....	2300-603
Option TL-4 .....	1000-600
Option LF .....	2300-405

REF.DES.	STOCK #	QUANTITY			DESCRIPTION	MANUFACTURING/PURCHASING DATA
		A	T	N		
3	2300-600		3		2300/01 Signal Processing Board Assembly	Assembly 2300-600
4	2300-601		1		2300 Main Board Assembly	Assembly 2300-601
5	2300-602		1		2300 Display Board Assembly	Assembly 2300-602
8	2300-410			1	2300 Shunt Plate Assy. (3 Phase)	Assembly 2300-410
10	04-10456		2		7.00" Side rail (upper right,lower left)	DWG 2300-223
12	04-10457		2		7.00" Side rail (upper left,lower right)	DWG 2300-224
13	04-10883			1	Aluminum Bottom Plate	DWG 2300-238
14	04-10884			1	Aluminum Top Cover	DWG 2300-239
15	04-10370		4		2703 Chassis Support Bar (corner block)	DWG 2703-212
16	04-10333		3		Standard Bezel	DWG 2724-205
17	04-10346		1		2300/2575A/4100 Main bd. support bar	DWG 2300-214
19	04-10882			1	Aluminum Flip Lid	DWG 2300-237
20	04-10503			1	2300 front panel (screened)	DWG 2300-100 using 04-10340
21	04-10342		1		2300/2301 Rear panel	DWG 2300-201
22	04-10345		2		2300 Windtunnel	DWG 2300-202
24	04-10332		2		Standard Corner Block	DWG 2724-204
25	04-10305		1		4300B Butch Plate	DWG 4300-213
27	05-10350		27		Grommet, caterpillar, .18" thick	Smith 2694
28	05-10166		1		Receptical, AC, filter	Corcom 6EF1
29	04-10900			1	Flip Lid Label	DWG 2300-104
34	05-10213		3		Card guide,snap-in,4.125 lg.,0.47 wide	Unitrack RAD4125
35	05-03017		1		Slide Switch,115/230V,2Pole	Switchcraft,4625LFR
36	05-10018		1		Fuseholder, panel mount	Littlefuse 345061
37	05-03061		1		Switch,Power,Black,Yellow,2PDT	Schadow,ZFNE152UEE11010106B
39	05-10317		2		Washer, nylon, shoulder, #4	Keystone 3053
40	05-10625		3		Grommet,I.D. 5/16", O.D. 5/8"	Smith 2174
41	05-10361		2		Foot, hard, rubber, grey	ACC.Rubber 2095W-017-GREY
44	05-10570		1		Hole Plug,Black,.687 Dia.	Heyco,2673(Black),DP-687
45	92-06004			7	#6-32 x 1/4" Phil Truss Head S.S.	
46	04-10469		1		2300 Main bd. support bar (front end)	DWG 2300-225
48	90-06009		2		#6-32 x 9/16" Phil Pan S.S.	
49	91-06006		5		#6-32 x 3/8" Phil Flat 82 Deg. S.S.	
50	90-06006		13		#6-32 x 3/8" Phil Pan S.S.	
51	90-06006			5	#6-32 x 3/8" Phil Pan S.S.	
52	90-04008		2		#4-40 x 1/2" Phil Pan S.S.	
53	91-06009		20		#6-32 x 9/16" Phil Flat 82 Deg. S.S.	
54	90-06004			2	#6-32 x 1/4" Phil Pan S.S.	
55	98-04001		4		#4 Split Lock Washer S.S.	
56	98-06002		23		#6 Internal Star Washer, S.S.	
57	90-06005		8		#6-32 x 5/16" Phil Pan S.S.	
58	05-10086		1		Solder lug, #6, internal star	Smith 1412-6
59	05-10431		2		Standoff, 1/4 hex, 3/8 lg, 6-32, M-F	RAF 4532-632-SS-0
60	97-06001		5		#6-32 Hex Nut, Small Pattern, Stainless-Steel	
61	05-10019		12		Cable tie, 4"x 1/8"	Panduit WRN-4
62	05-10261		3		Tie-wrap block, large	Panduit ABM2S-A
63	80-01516		18		16awg Wire, Green PVC	M16878/1-BJE-5
64	80-01218		48		18awg Wire, Red PVC	M16878/1-BHE-2
65	80-01018		48		18awg Wire, Black PVC	M16878/1-BHE-0
66	80-01918		48		18awg Wire, White PVC	M16878/1-BHE-9
67	80-01518		48		18awg Wire, Green PVC	M16878/1-BHE-5
68	70-00008		36		1/2" Black Shrink Tubing	ANX 364-011-0500-02

REF.DES.	STOCK #	QUANTITY			DESCRIPTION	MANUFACTURING/PURCHASING DATA
		A	T	N		
73	90-06007	4			#6-32 x 7/16" Phil Pan S.S.	
75	97-04001	2			#4-40 Radio Hex Nut S.S.	
77	05-04002	1			1A,Slo Blo Fuse	Littlefuse,313-001
79	05-10808	2			Dual Tilting Feet (Plastic,Gray)	Elma Electronics 63-018S
80	91-06010	2			#6-32 x 5/8" Phil Flat 82 Deg. S.S.	

REF.DES.	STOCK #	QUANTITY			DESCRIPTION	MANUFACTURING/PURCHASING DATA	ALTERNATE
		A	T	N			
76	05-10311	5			Standoff, 3/16 hex, 1/2 lg, 4-40	Keystone 1656	
77	05-10312	5			Spacer, 3/16 hex, 1/8 lg, #4	Smith 9115 or 9015	
78	90-04006	10			#4-40 x 3/8" Phil Pan S.S.		
79	98-04001	10			#4 Split Lock Washer S.S.		
81	04-10357	1			2300 Signal processing bd. shield (front)	DWG 2300-217	
82	04-10358	1			2300 Signal processing bd. shield (back)	DWG 2300-221	
83	04-10706	1			2300 Shield Overlay	DWG 2300-102	
84	80-00022	3			22AWG Bus Wire	1BB-2201 ANIXTER	
A1	04-30073	1			2300 Signal Processing Board	DWG 2300-700	
C2	02-10998		1		Factory Select Capacitor		
C3	02-10998		1		Factory Select Capacitor		
C4	02-10998		1		Factory Select Capacitor		
C5	02-30004	1			1uF 25V Tantalum Bead	Kemet T350A105K025AS	
C6	02-60015	1			0.022uF, 100V, Mylar, 5%	WIMA MKC2-0.022uF	
C8	02-10998		1		Factory Select Capacitor		
C9	02-10998		1		Factory Select Capacitor		
C10	02-10998		1		Factory Select Capacitor		
C11	02-30004	1			1uF 25V Tantalum Bead	Kemet T350A105K025AS	
C12	02-60015	1			0.022uF, 100V, Mylar, 5%	WIMA MKC2-0.022uF	
C13	02-10014	1			0.1uF 50V Ceramic Disc	AVX SR205E104MAA00	
C14	02-30011	1			4.7u 35V Tantalum Bead	TDC475K035WLE	
C15	02-10014	1			0.1uF 50V Ceramic Disc	AVX SR205E104MAA00	
C16	02-30001	1			10uF 25V Tantalum Bead	AVX TAP106K025SP	
C17	02-10006	1			0.01uF 50V Ceramic disc	Illinois 103GR050-Z	
C18	02-90005	1			0.1uF 5% 50V Polycarbonate	IMB RA7A104J	
C19	02-10014	1			0.1uF 50V Ceramic Disc	AVX SR205E104MAA00	
C20	02-10014	1			0.1uF 50V Ceramic Disc	AVX SR205E104MAA00	
C21	02-30011	1			4.7u 35V Tantalum Bead	TDC475K035WLE	
C22	02-30001	1			10uF 25V Tantalum Bead	AVX TAP106K025SP	
C23	02-10006	1			0.01uF 50V Ceramic disc	Illinois 103GR050-Z	
C24	02-90004	1			0.01uF 5% 50V Polycarbonate	IBM RA7A103J	
C25	02-60015	1			0.022uF, 100V, Mylar, 5%	WIMA MKC2-0.022uF	
C26	02-10006	1			0.01uF 50V Ceramic disc	Illinois 103GR050-Z	
C27	02-60015	1			0.022uF, 100V, Mylar, 5%	WIMA MKC2-0.022uF	
C28	02-60015	1			0.022uF, 100V, Mylar, 5%	WIMA MKC2-0.022uF	
C29	02-10006	1			0.01uF 50V Ceramic disc	Illinois 103GR050-Z	
C30	02-60015	1			0.022uF, 100V, Mylar, 5%	WIMA MKC2-0.022uF	
C31	02-60015	1			0.022uF, 100V, Mylar, 5%	WIMA MKC2-0.022uF	
C32	02-60015	1			0.022uF, 100V, Mylar, 5%	WIMA MKC2-0.022uF	
C33	02-10006	1			0.01uF 50V Ceramic disc	Illinois 103GR050-Z	
C34	02-10006	1			0.01uF 50V Ceramic disc	Illinois 103GR050-Z	
C35	02-10006	1			0.01uF 50V Ceramic disc	Illinois 103GR050-Z	
C36	02-10006	1			0.01uF 50V Ceramic disc	Illinois 103GR050-Z	
C37	02-10006	1			0.01uF 50V Ceramic disc	Illinois 103GR050-Z	
CR1	03-20000	1			Diode, general purpose	1N4148 or 1N914	
CR2	03-20000	1			Diode, general purpose	1N4148 or 1N914	
CR3	03-20000	1			Diode, general purpose	1N4148 or 1N914	
CR4	03-20007	1			Zener, reference, 6.3V, 10ppm/c, 5%	1N827	
CR5	03-20007	1			Zener, reference, 6.3V, 10ppm/c, 5%	1N827	
CR6	03-20000	1			Diode, general purpose	1N4148 or 1N914	
CR7	03-20000	1			Diode, general purpose	1N4148 or 1N914	

REF.DES.	STOCK #	QUANTITY			DESCRIPTION	MANUFACTURING/PURCHASING DATA	ALTERNATE
		A	T	N			
CR8	03-20000	1			Diode, general purpose	1N4148 or 1N914	
CR9	03-20000	1			Diode, general purpose	1N4148 or 1N914	
CR10	03-20000	1			Diode, general purpose	1N4148 or 1N914	
IC1	03-30200	1			Dual 4 to 1 analog switch (CMOS)	4052BE	
IC2	03-30104	1			General purpose uncompensated JFET Op-amp	LF357H or N	
IC3	03-30090	1			General Purpose JFET Op-Amp	LF356N or H (ALT 03-30074)	
IC4	03-30090	1			General Purpose JFET Op-Amp	LF356N or H (ALT 03-30074)	
IC5	03-30133	1			Quad general purpose comparator	LM339N	
IC6	03-30201	1			Dual general purpose opto-isolator	ILCT6 or MCT6	
IC7	03-30133	1			Quad general purpose comparator	LM339N	
IC8	03-30045	1			RMS to DC Converter	Analog Devices AD536ADJ or H	
IC9	03-30202	1			Analog Multiplier	Analog Devices AD534KH	
IC10	03-30045	1			RMS to DC Converter	Analog Devices AD536ADJ or H	
IC11	03-30090	1			General Purpose JFET Op-Amp	LF356N or H (ALT 03-30074)	
IC12	03-30090	1			General Purpose JFET Op-Amp	LF356N or H (ALT 03-30074)	
IC13	03-30133	1			Quad general purpose comparator	LM339N	
IC14	03-30145	1			High gain high speed Opto-isolator	6N136	
IC15	03-30145	1			High gain high speed Opto-isolator	6N136	
IC16	03-30145	1			High gain high speed Opto-isolator	6N136	
IC17	03-30185	1			Quad general purpose Opto-isolator	Litronix ILQ-74A	
IC18	03-30185	1			Quad general purpose Opto-isolator	Litronix ILQ-74A	
J2	05-10300	1			Wafer, 10 pin, .156 spacing	Molex 09-67-1103	
K1	05-03070	1			Relay, Reed, 1 Form A, 12V	Claire, PRMA1A12	
K2	05-03070	1			Relay, Reed, 1 Form A, 12V	Claire, PRMA1A12	
K3	05-03070	1			Relay, Reed, 1 Form A, 12V	Claire, PRMA1A12	
K4	05-03070	1			Relay, Reed, 1 Form A, 12V	Claire, PRMA1A12	
K5	05-03070	1			Relay, Reed, 1 Form A, 12V	Claire, PRMA1A12	
PL1	05-10310	1			Socket, right angle, 10 way, gold	Molex 22-16-2101	
PL2	05-10310	1			Socket, right angle, 10 way, gold	Molex 22-16-2101	
PL3	05-10310	1			Socket, right angle, 10 way, gold	Molex 22-16-2101	
R1	01-01081	1			100K 5% 1/4W Carbon Film	RC07GF104J	
R2	01-01081	1			100K 5% 1/4W Carbon Film	RC07GF104J	
R3	01-50035	1			50K End Adjust	Beckman 89PR50K	
R5	01-50025	1			100 End Adjust	Beckman 89PR100ohm	
R6	01-10058	1			909 1% 50ppm/C 1/4W Metal Film	RN60C9090F	
R7	01-50025	1			100 End Adjust	Beckman 89PR100ohm	
R8	01-10058	1			909 1% 50ppm/C 1/4W Metal Film	RN60C9090F	
R9	01-50035	1			50K End Adjust	Beckman 89PR50K	
R10	01-01119	1			10M 5% 1/4W Carbon Film	RC07GF106J	
R11	01-10007	1			1.0M 1% 50ppm/C 1/4W Metal Film	RN55C1004F	
R12	01-50022	1			1K End Adjust	Beckman 89PR1K	
R13	01-10325	1			6.04K 1% 50ppm/C 1/4W Metal Film	RN60C6041F	
R14	01-10136	1			18.2K 1% 50ppm/C 1/4W Metal Film	RN60C1822F	
R15	01-50042	1			5K End Adjust	Beckman 89PR5K	
R16	01-50042	1			5K End Adjust	Beckman 89PR5K	
R17	01-10136	1			18.2K 1% 50ppm/C 1/4W Metal Film	RN60C1822F	
R18	01-01081	1			100K 5% 1/4W Carbon Film	RC07GF104J	
R19	01-01043	1			1.5K 5% 1/4W Carbon Film	RC07GF152J	
R20	01-01085	1			200K 5% 1/4W Carbon Film	RC07GF204J	
R21	01-10048	1			1M 1% 50ppm/C 1/2W Metal Film	RN65C1004F	
R22	01-50041	1			2K End Adjust	Beckman 89PR2K	

REF.DES.	STOCK #	QUANTITY			DESCRIPTION	MANUFACTURING/PURCHASING DATA	ALTERNATE
		A	T	N			
R23	01-10108	1			7.5K 1% 50ppm/C 1/4W Metal Film	RN60C7501F	
R24	01-10008	1			10K 1% 50ppm/C 1/4W Metal Film	RN60C1002F	
R25	01-50022	1			1K End Adjust	Beckman 89PR1K	
R26	01-10126	1			9.53K 1% 50ppm/C 1/4W Metal Film	RN60C9531F	
R27	01-50043	1			200 End Adjust	Beckman 89PR200ohm	
R28	01-10177	1			3.24K 1% 50ppm/C 1/4W Metal Film	RN60C3241F	
R29	01-50020	1			50 End Adjust	Beckman 89PR50ohm	
R30	01-10105	1			887 1% 50ppm/C 1/4W Metal Film	RN60C8870F	
R31	01-01043	1			1.5K 5% 1/4W Carbon Film	RC07GF152J	
R32	01-01085	1			200K 5% 1/4W Carbon Film	RC07GF204J	
R33	01-01047	1			2.4K 5% 1/4W Carbon Film	RC07GF242J	
R34	01-01061	1			10K 5% 1/4W Carbon Film	RC07GF103J	
R35	01-01061	1			10K 5% 1/4W Carbon Film	RC07GF103J	
R36	01-01047	1			2.4K 5% 1/4W Carbon Film	RC07GF242J	
R37	01-01061	1			10K 5% 1/4W Carbon Film	RC07GF103J	
R38	01-01061	1			10K 5% 1/4W Carbon Film	RC07GF103J	
R39	01-01081	1			100K 5% 1/4W Carbon Film	RC07GF104J	
R40	01-50035	1			50K End Adjust	Beckman 89PR50K	
R41	01-10000			1	FACTORY SELECT VALUE (1%)	RN60CXX	
R42	01-10008	1			10K 1% 50ppm/C 1/4W Metal Film	RN60C1002F	
R43	01-10008	1			10K 1% 50ppm/C 1/4W Metal Film	RN60C1002F	
R44	01-01041	1			1K 5% 1/4W Carbon Film	RC07GF102J	
R45	01-10008	1			10K 1% 50ppm/C 1/4W Metal Film	RN60C1002F	
R46	01-01061	1			10K 5% 1/4W Carbon Film	RC07GF103J	
R47	01-01061	1			10K 5% 1/4W Carbon Film	RC07GF103J	
R48	01-01061	1			10K 5% 1/4W Carbon Film	RC07GF103J	
R49	01-01061	1			10K 5% 1/4W Carbon Film	RC07GF103J	
R50	01-01061	1			10K 5% 1/4W Carbon Film	RC07GF103J	
R51	01-01045	1			2K 5% 1/4W Carbon Film	RC07GF202J	
R52	01-01061	1			10K 5% 1/4W Carbon Film	RC07GF103J	
R53	01-01085	1			200K 5% 1/4W Carbon Film	RC07GF204J	
R54	01-01045	1			2K 5% 1/4W Carbon Film	RC07GF202J	
R55	01-01061	1			10K 5% 1/4W Carbon Film	RC07GF103J	
R56	01-01085	1			200K 5% 1/4W Carbon Film	RC07GF204J	
R57	01-01045	1			2K 5% 1/4W Carbon Film	RC07GF202J	
R58	01-01061	1			10K 5% 1/4W Carbon Film	RC07GF103J	
R59	01-01085	1			200K 5% 1/4W Carbon Film	RC07GF204J	
RN1	01-40001	1			8 x 470 Network	A-B 316B-471	
TR1	03-10013	1			NPN Transistor (TO92)	2N4401	
TR2	03-10013	1			NPN Transistor (TO92)	2N4401	
TR3	03-10013	1			NPN Transistor (TO92)	2N4401	
TR4	03-10013	1			NPN Transistor (TO92)	2N4401	
TR5	03-10013	1			NPN Transistor (TO92)	2N4401	



REF.DES.	STOCK #	QUANTITY			DESCRIPTION	MANUFACTURING/PURCHASING DATA	ALTERNATE
		A	T	N			
6	05-10042	1			Socket, dil, 24 pin	TI 8524-01	
7	05-10313	13			Wafer, 10 way, gold, 0.56 lg	Molex 22-10-2101	
71	90-06006	2			#6-32 x 3/8" Phil Pan S.S.		
72	98-06002	2			#6 Internal Star Washer, S.S.		
73	97-06001	2			#6-32 Hex Nut, Small Pattern, Stainless-Steel		
75	80-03230	6			30awg Wire, Red Kynar		
77	05-10582	1			Cable Tie 8.0"lg x .10"wide	Panduit PLT2M	
A1	04-30074	1			2300 Main Board	DWG 2300-701	
C1	02-40013	1			470uF 50V Aluminum	Illinois 477TTA050	
C2	02-40013	1			470uF 50V Aluminum	Illinois 477TTA050	
C3	02-30004	1			1uF 25V Tantalum Bead	Kemet T350A105K025AS	
C4	02-30004	1			1uF 25V Tantalum Bead	Kemet T350A105K025AS	
C5	02-40012	1			15000uF 16V Aluminum	Illinois 159TTA016	
C6	02-30001	1			10uF 25V Tantalum Bead	AVX TAP106K025SP	
C7	02-10014	1			0.1uF 50V Ceramic Disc	AVX SR205E104MAA00	
C8	02-10014	1			0.1uF 50V Ceramic Disc	AVX SR205E104MAA00	
C9	02-10014	1			0.1uF 50V Ceramic Disc	AVX SR205E104MAA00	
C10	02-10014	1			0.1uF 50V Ceramic Disc	AVX SR205E104MAA00	
C11	02-10014	1			0.1uF 50V Ceramic Disc	AVX SR205E104MAA00	
C12	02-10014	1			0.1uF 50V Ceramic Disc	AVX SR205E104MAA00	
C13	02-10004	1			0.02uF 500V Ceramic disc	SPRAGUE 140CD500Z9-203Z	
C14	02-10004	1			0.02uF 500V Ceramic disc	SPRAGUE 140CD500Z9-203Z	
C15	02-10004	1			0.02uF 500V Ceramic disc	SPRAGUE 140CD500Z9-203Z	
C16	02-10004	1			0.02uF 500V Ceramic disc	SPRAGUE 140CD500Z9-203Z	
C17	02-10004	1			0.02uF 500V Ceramic disc	SPRAGUE 140CD500Z9-203Z	
C18	02-10004	1			0.02uF 500V Ceramic disc	SPRAGUE 140CD500Z9-203Z	
C19	02-30003	1			47uF 10V Tantalum Bead	AVX TAP476M020SP	
C20	02-30003	1			47uF 10V Tantalum Bead	AVX TAP476M020SP	
CR1	03-20002	1			Diode, rectifier, 1A, 50V	1N4001-1N4007	
CR2	03-20002	1			Diode, rectifier, 1A, 50V	1N4001-1N4007	
CR3	03-20002	1			Diode, rectifier, 1A, 50V	1N4001-1N4007	
CR4	03-20002	1			Diode, rectifier, 1A, 50V	1N4001-1N4007	
CR5	03-20049	1			Diode, Rectifier, 3A, 50v	Motorola MR500	
CR6	03-20049	1			Diode, Rectifier, 3A, 50v	Motorola MR500	
CR7	03-20000	1			Diode, general purpose	1N4148 or 1N914	
CR8	03-20000	1			Diode, general purpose	1N4148 or 1N914	
CR9	03-20000	1			Diode, general purpose	1N4148 or 1N914	
C101	02-40013	1			470uF 50V Aluminum	Illinois 477TTA050	
C102	02-40013	1			470uF 50V Aluminum	Illinois 477TTA050	
C103	02-30004	1			1uF 25V Tantalum Bead	Kemet T350A105K025AS	
C104	02-30004	1			1uF 25V Tantalum Bead	Kemet T350A105K025AS	
C105	02-60000	1			.0047uF 100V Mylar	Illinois 472SHR100K59CE	
C106	02-60000	1			.0047uF 100V Mylar	Illinois 472SHR100K59CE	
C107	02-60000	1			.0047uF 100V Mylar	Illinois 472SHR100K59CE	
C108	02-60000	1			.0047uF 100V Mylar	Illinois 472SHR100K59CE	
C109	02-60000	1			.0047uF 100V Mylar	Illinois 472SHR100K59CE	
C110	02-60000	1			.0047uF 100V Mylar	Illinois 472SHR100K59CE	
C111	02-10006	1			0.01uF 50V Ceramic disc	Illinois 103GR050-Z	
C201	02-40013	1			470uF 50V Aluminum	Illinois 477TTA050	
C202	02-40013	1			470uF 50V Aluminum	Illinois 477TTA050	
C203	02-30004	1			1uF 25V Tantalum Bead	Kemet T350A105K025AS	

REF.DES.	STOCK #	QUANTITY	DESCRIPTION	MANUFACTURING/PURCHASING DATA	ALTERNATE
C204	02-30004	1	1uF 25V Tantalum Bead	Kemet T350A105K025AS	
C205	02-60000	1	.0047uF 100V Mylar	Illinois 472SHR100K59CE	
C206	02-60000	1	.0047uF 100V Mylar	Illinois 472SHR100K59CE	
C207	02-60000	1	.0047uF 100V Mylar	Illinois 472SHR100K59CE	
C208	02-60000	1	.0047uF 100V Mylar	Illinois 472SHR100K59CE	
C209	02-60000	1	.0047uF 100V Mylar	Illinois 472SHR100K59CE	
C210	02-60000	1	.0047uF 100V Mylar	Illinois 472SHR100K59CE	
C211	02-10006	1	0.01uF 50V Ceramic disc	Illinois 103GR050-Z	
C301	02-40013	1	470uF 50V Aluminum	Illinois 477TTA050	
C302	02-40013	1	470uF 50V Aluminum	Illinois 477TTA050	
C303	02-30004	1	1uF 25V Tantalum Bead	Kemet T350A105K025AS	
C304	02-30004	1	1uF 25V Tantalum Bead	Kemet T350A105K025AS	
C305	02-60000	1	.0047uF 100V Mylar	Illinois 472SHR100K59CE	
C306	02-60000	1	.0047uF 100V Mylar	Illinois 472SHR100K59CE	
C307	02-60000	1	.0047uF 100V Mylar	Illinois 472SHR100K59CE	
C308	02-60000	1	.0047uF 100V Mylar	Illinois 472SHR100K59CE	
C309	02-60000	1	.0047uF 100V Mylar	Illinois 472SHR100K59CE	
C310	02-60000	1	.0047uF 100V Mylar	Illinois 472SHR100K59CE	
C311	02-10006	1	0.01uF 50V Ceramic disc	Illinois 103GR050-Z	
CR10	03-20000	1	Diode, general purpose	1N4148 or 1N914	
CR17	03-20007	1	Zener, reference, 6.3V, 10ppm/c, 5%	1N827	
CR18	03-20007	1	Zener, reference, 6.3V, 10ppm/c, 5%	1N827	
CR101	03-20002	1	Diode, rectifier, 1A, 50V	1N4001-1N4007	
CR102	03-20002	1	Diode, rectifier, 1A, 50V	1N4001-1N4007	
CR103	03-20002	1	Diode, rectifier, 1A, 50V	1N4001-1N4007	
CR104	03-20002	1	Diode, rectifier, 1A, 50V	1N4001-1N4007	
CR111	03-20000	1	Diode, general purpose	1N4148 or 1N914	
CR112	03-20000	1	Diode, general purpose	1N4148 or 1N914	
CR113	03-20000	1	Diode, general purpose	1N4148 or 1N914	
CR114	03-20000	1	Diode, general purpose	1N4148 or 1N914	
CR115	03-20000	1	Diode, general purpose	1N4148 or 1N914	
CR116	03-20000	1	Diode, general purpose	1N4148 or 1N914	
CR201	03-20002	1	Diode, rectifier, 1A, 50V	1N4001-1N4007	
CR202	03-20002	1	Diode, rectifier, 1A, 50V	1N4001-1N4007	
CR203	03-20002	1	Diode, rectifier, 1A, 50V	1N4001-1N4007	
CR204	03-20002	1	Diode, rectifier, 1A, 50V	1N4001-1N4007	
CR211	03-20000	1	Diode, general purpose	1N4148 or 1N914	
CR212	03-20000	1	Diode, general purpose	1N4148 or 1N914	
CR213	03-20000	1	Diode, general purpose	1N4148 or 1N914	
CR214	03-20000	1	Diode, general purpose	1N4148 or 1N914	
CR215	03-20000	1	Diode, general purpose	1N4148 or 1N914	
CR216	03-20000	1	Diode, general purpose	1N4148 or 1N914	
CR301	03-20002	1	Diode, rectifier, 1A, 50V	1N4001-1N4007	
CR302	03-20002	1	Diode, rectifier, 1A, 50V	1N4001-1N4007	
CR303	03-20002	1	Diode, rectifier, 1A, 50V	1N4001-1N4007	
CR304	03-20002	1	Diode, rectifier, 1A, 50V	1N4001-1N4007	
CR311	03-20000	1	Diode, general purpose	1N4148 or 1N914	
CR312	03-20000	1	Diode, general purpose	1N4148 or 1N914	
CR313	03-20000	1	Diode, general purpose	1N4148 or 1N914	
CR314	03-20000	1	Diode, general purpose	1N4148 or 1N914	
CR315	03-20000	1	Diode, general purpose	1N4148 or 1N914	

REF.DES.	STOCK #	QUANTITY			DESCRIPTION	MANUFACTURING/PURCHASING DATA	ALTERNATE
		A	T	N			
CR316	03-20000	1			Diode, general purpose	1N4148 or 1N914	
IC1	03-30036	1			Regulator,+15V,0.5A,TO202 or TO220	78M15CP or LM340T-15	
IC2	03-30037	1			Regulator,-15V,0.5A,TO202 or TO220	79M15CP or LM320T-15	
IC3	03-30355	1			Regulator, +5V, 3A,TO-3 Steel	LM323KC	
IC4	03-30170	1			Low Noise, low drift Op-amp	OP07DP	
IC5	03-30203	1			8 to 1 multiplexor	4051BE	
IC6	03-30203	1			8 to 1 multiplexor	4051BE	
IC7	03-30203	1			8 to 1 multiplexor	4051BE	
IC8	03-50008	1			2300 Family IC8	Made from 03-30154	
IC9	03-30164	1			Hex buffer open collector (30V)	7407	
IC10	03-30164	1			Hex buffer open collector (30V)	7407	
IC11	03-30205	1			Dual Monostable (CMOS)	4528BE	
IC12	03-30205	1			Dual Monostable (CMOS)	4528BE	
IC13	03-30205	1			Dual Monostable (CMOS)	4528BE	
IC14	03-30326	1			Dual General Purpose Op Amp	LM358AN	
IC101	03-30036	1			Regulator,+15V,0.5A,TO202 or TO220	78M15CP or LM340T-15	
IC102	03-30037	1			Regulator,-15V,0.5A,TO202 or TO220	79M15CP or LM320T-15	
IC103	03-30133	1			Quad general purpose comparator	LM339N	
IC104	03-30090	1			General Purpose JFET Op-Amp	LF356N or H (ALT 03-30074)	
IC105	03-30090	1			General Purpose JFET Op-Amp	LF356N or H (ALT 03-30074)	
IC106	03-30090	1			General Purpose JFET Op-Amp	LF356N or H (ALT 03-30074)	
IC201	03-30036	1			Regulator,+15V,0.5A,TO202 or TO220	78M15CP or LM340T-15	
IC202	03-30037	1			Regulator,-15V,0.5A,TO202 or TO220	79M15CP or LM320T-15	
IC203	03-30133	1			Quad general purpose comparator	LM339N	
IC204	03-30090	1			General Purpose JFET Op-Amp	LF356N or H (ALT 03-30074)	
IC205	03-30090	1			General Purpose JFET Op-Amp	LF356N or H (ALT 03-30074)	
IC206	03-30090	1			General Purpose JFET Op-Amp	LF356N or H (ALT 03-30074)	
IC301	03-30036	1			Regulator,+15V,0.5A,TO202 or TO220	78M15CP or LM340T-15	
IC302	03-30037	1			Regulator,-15V,0.5A,TO202 or TO220	79M15CP or LM320T-15	
IC303	03-30133	1			Quad general purpose comparator	LM339N	
IC304	03-30090	1			General Purpose JFET Op-Amp	LF356N or H (ALT 03-30074)	
IC305	03-30090	1			General Purpose JFET Op-Amp	LF356N or H (ALT 03-30074)	
IC306	03-30090	1			General Purpose JFET Op-Amp	LF356N or H (ALT 03-30074)	
K1	05-03012	1			Relay, Reed, 5V Coil, DIL, Form A	CP Clare: PRMA 1A 05	
K2	05-03012	1			Relay, Reed, 5V Coil, DIL, Form A	CP Clare: PRMA 1A 05	
K3	05-03012	1			Relay, Reed, 5V Coil, DIL, Form A	CP Clare: PRMA 1A 05	
K4	05-03012	1			Relay, Reed, 5V Coil, DIL, Form A	CP Clare: PRMA 1A 05	
K5	05-03012	1			Relay, Reed, 5V Coil, DIL, Form A	CP Clare: PRMA 1A 05	
K6	05-03012	1			Relay, Reed, 5V Coil, DIL, Form A	CP Clare: PRMA 1A 05	
K7	05-03012	1			Relay, Reed, 5V Coil, DIL, Form A	CP Clare: PRMA 1A 05	
K8	05-03012	1			Relay, Reed, 5V Coil, DIL, Form A	CP Clare: PRMA 1A 05	
K9	05-03012	1			Relay, Reed, 5V Coil, DIL, Form A	CP Clare: PRMA 1A 05	
K10	05-03012	1			Relay, Reed, 5V Coil, DIL, Form A	CP Clare: PRMA 1A 05	
R1	01-01077	1			68K 5% 1/4W Carbon Film	RC07GF683J	
R2	01-01077	1			68K 5% 1/4W Carbon Film	RC07GF683J	
R3	01-01077	1			68K 5% 1/4W Carbon Film	RC07GF683J	
R4	01-01077	1			68K 5% 1/4W Carbon Film	RC07GF683J	
R5	01-10178	1			10K 0.1% 25ppm/C 1/8W Metal Film	PRP 1/8W - 10K - 0.1% - 25PPM	
R6	01-10178	1			10K 0.1% 25ppm/C 1/8W Metal Film	PRP 1/8W - 10K - 0.1% - 25PPM	
R7	01-10178	1			10K 0.1% 25ppm/C 1/8W Metal Film	PRP 1/8W - 10K - 0.1% - 25PPM	
R8	01-10168	1			1.11K 0.1% 25ppm/C 1/8W Metal Film	PRP 1/8W -1.11K -0.1% -25PPM	

REF.DES.	STOCK #	QUANTITY			DESCRIPTION	MANUFACTURING/PURCHASING DATA	ALTERNATE
		A	T	N			
R9	01-10178	1			10K 0.1% 25ppm/C 1/8W Metal Film	PRP 1/8W - 10K - 0.1% - 25PPM	
R10	01-10017	1			9.09K 1% 50ppm/C 1/4W Metal Film	RN60C9091F	
R11	01-50014	1			100 Top Adjust	Beckman 68WR100ohm	
R12	01-10110	1			1.13K 1% 50ppm/C 1/4W Metal Film	RN60C1131F	
R13	01-50033	1			50 Top Adjust	Beckman 68WR50ohm	
R14	01-10014	1			698 1% 50ppm/C 1/4W Metal Film	RN60C6980F	
R15	01-50033	1			50 Top Adjust	Beckman 68WR50ohm	
R16	01-10157	1			475 1% 50ppm/C 1/4W Metal Film	RN60C4750F	
R17	01-10017	1			9.09K 1% 50ppm/C 1/4W Metal Film	RN60C9091F	
R18	01-50037	1			200 Top Adjust	Beckman 68WR200ohm	
R19	01-10053	1			2.43K 1% 50ppm/C 1/4W Metal Film	RN60C2431F	
R20	01-50014	1			100 Top Adjust	Beckman 68WR100ohm	
R21	01-10167	1			200 1% 50ppm/C 1/4W Metal Film	RN60C2000F	
R22	01-50014	1			100 Top Adjust	Beckman 68WR100ohm	
R23	01-10172	1			511 1% 50ppm/C 1/4W Metal Film	RN60C5110F	
R24	01-50033	1			50 Top Adjust	Beckman 68WR50ohm	
R25	01-10133	1			845 1% 50ppm/C 1/4W Metal Film	RN60C8450F	
R26	01-10112	1			2.80K 1% 50ppm/C 1/4W Metal Film	RN60C2801F	
R27	01-50037	1			200 Top Adjust	Beckman 68WR200ohm	
R28	01-10070	1			649 1% 50ppm/C 1/4W Metal Film	RN60C6490F	
R29	01-50037	1			200 Top Adjust	Beckman 68WR200ohm	
R30	01-10173	1			365 1% 50ppm/C 1/4W Metal Film	RN60C3650F	
R31	01-50037	1			200 Top Adjust	Beckman 68WR200ohm	
R32	01-10021	1			604 1% 50ppm/C 1/4W Metal Film	RN60C6040F	
R33	01-50014	1			100 Top Adjust	Beckman 68WR100ohm	
R34	01-10175	1			324 1% 50ppm/C 1/4W Metal Film	RN60C3240F	
R35	01-50014	1			100 Top Adjust	Beckman 68WR100ohm	
R36	01-10138	1			182 1% 50ppm/C 1/4W Metal Film	RN60C1820F	
R37	01-50014	1			100 Top Adjust	Beckman 68WR100ohm	
R38	01-10172	1			511 1% 50ppm/C 1/4W Metal Film	RN60C5110F	
R39	01-50033	1			50 Top Adjust	Beckman 68WR50ohm	
R40	01-10051	1			100 1% 50ppm/C 1/4W Metal Film	RN60C1000F	
R41	01-50033	1			50 Top Adjust	Beckman 68WR50ohm	
R42	01-10014	1			698 1% 50ppm/C 1/4W Metal Film	RN60C6980F	
R44	01-01061	1			10K 5% 1/4W Carbon Film	RC07GF103J	
R45	01-01061	1			10K 5% 1/4W Carbon Film	RC07GF103J	
R46	01-01061	1			10K 5% 1/4W Carbon Film	RC07GF103J	
R47	01-01061	1			10K 5% 1/4W Carbon Film	RC07GF103J	
R48	01-01061	1			10K 5% 1/4W Carbon Film	RC07GF103J	
R49	01-01061	1			10K 5% 1/4W Carbon Film	RC07GF103J	
R53	01-01045	1			2K 5% 1/4W Carbon Film	RC07GF202J	
R54	01-01045	1			2K 5% 1/4W Carbon Film	RC07GF202J	
R55	01-01081	1			100K 5% 1/4W Carbon Film	RC07GF104J	
R56	01-01083	1			150K 5% 1/4W Carbon Film	RC07GF154J	
R57	01-01083	1			150K 5% 1/4W Carbon Film	RC07GF154J	
R58	01-01081	1			100K 5% 1/4W Carbon Film	RC07GF104J	
R59	01-01081	1			100K 5% 1/4W Carbon Film	RC07GF104J	
R60	01-01083	1			150K 5% 1/4W Carbon Film	RC07GF154J	
R61	01-01083	1			150K 5% 1/4W Carbon Film	RC07GF154J	
R62	01-01081	1			100K 5% 1/4W Carbon Film	RC07GF104J	
R63	01-01081	1			100K 5% 1/4W Carbon Film	RC07GF104J	

REF.DES.	STOCK #	QUANTITY			DESCRIPTION	MANUFACTURING/PURCHASING DATA	ALTERNATE
		A	T	N			
R64	01-01083	1			150K 5% 1/4W Carbon Film	RC07GF154J	
R65	01-01083	1			150K 5% 1/4W Carbon Film	RC07GF154J	
R66	01-01081	1			100K 5% 1/4W Carbon Film	RC07GF104J	
R102	01-01074	1			51K 5% 1/4W Carbon Film	RC07GF513J	
R103	01-01083	1			150K 5% 1/4W Carbon Film	RC07GF154J	
R104	01-01061	1			10K 5% 1/4W Carbon Film	RC07GF103J	
R105	01-10111	1			1.24M 1% 50ppm/C 1/4W Metal Film	RN60C1244F	
R106	01-10111	1			1.24M 1% 50ppm/C 1/4W Metal Film	RN60C1244F	
R107	01-01081	1			100K 5% 1/4W Carbon Film	RC07GF104J	
R108	01-01081	1			100K 5% 1/4W Carbon Film	RC07GF104J	
R109	01-01041	1			1K 5% 1/4W Carbon Film	RC07GF102J	
R110	01-50028	1			50K Top Adjust	Beckman 68WR50K	
R111	01-01081	1			100K 5% 1/4W Carbon Film	RC07GF104J	
R112	01-01081	1			100K 5% 1/4W Carbon Film	RC07GF104J	
R113	01-01061	1			10K 5% 1/4W Carbon Film	RC07GF103J	
R114	01-10111	1			1.24M 1% 50ppm/C 1/4W Metal Film	RN60C1244F	
R115	01-10111	1			1.24M 1% 50ppm/C 1/4W Metal Film	RN60C1244F	
R116	01-01081	1			100K 5% 1/4W Carbon Film	RC07GF104J	
R117	01-01081	1			100K 5% 1/4W Carbon Film	RC07GF104J	
R118	01-01041	1			1K 5% 1/4W Carbon Film	RC07GF102J	
R119	01-50028	1			50K Top Adjust	Beckman 68WR50K	
R120	01-01081	1			100K 5% 1/4W Carbon Film	RC07GF104J	
R122	01-01061	1			10K 5% 1/4W Carbon Film	RC07GF103J	
R123	01-10111	1			1.24M 1% 50ppm/C 1/4W Metal Film	RN60C1244F	
R124	01-10111	1			1.24M 1% 50ppm/C 1/4W Metal Film	RN60C1244F	
R125	01-01081	1			100K 5% 1/4W Carbon Film	RC07GF104J	
R126	01-01081	1			100K 5% 1/4W Carbon Film	RC07GF104J	
R127	01-01041	1			1K 5% 1/4W Carbon Film	RC07GF102J	
R128	01-50028	1			50K Top Adjust	Beckman 68WR50K	
R130	01-01061	1			10K 5% 1/4W Carbon Film	RC07GF103J	
R131	01-01061	1			10K 5% 1/4W Carbon Film	RC07GF103J	
R202	01-01074	1			51K 5% 1/4W Carbon Film	RC07GF513J	
R203	01-01083	1			150K 5% 1/4W Carbon Film	RC07GF154J	
R204	01-01061	1			10K 5% 1/4W Carbon Film	RC07GF103J	
R205	01-10111	1			1.24M 1% 50ppm/C 1/4W Metal Film	RN60C1244F	
R206	01-10111	1			1.24M 1% 50ppm/C 1/4W Metal Film	RN60C1244F	
R207	01-01081	1			100K 5% 1/4W Carbon Film	RC07GF104J	
R208	01-01081	1			100K 5% 1/4W Carbon Film	RC07GF104J	
R209	01-01041	1			1K 5% 1/4W Carbon Film	RC07GF102J	
R210	01-50028	1			50K Top Adjust	Beckman 68WR50K	
R211	01-01081	1			100K 5% 1/4W Carbon Film	RC07GF104J	
R212	01-01081	1			100K 5% 1/4W Carbon Film	RC07GF104J	
R213	01-01061	1			10K 5% 1/4W Carbon Film	RC07GF103J	
R214	01-10111	1			1.24M 1% 50ppm/C 1/4W Metal Film	RN60C1244F	
R215	01-10111	1			1.24M 1% 50ppm/C 1/4W Metal Film	RN60C1244F	
R216	01-01081	1			100K 5% 1/4W Carbon Film	RC07GF104J	
R217	01-01081	1			100K 5% 1/4W Carbon Film	RC07GF104J	
R218	01-01041	1			1K 5% 1/4W Carbon Film	RC07GF102J	
R219	01-50028	1			50K Top Adjust	Beckman 68WR50K	
R220	01-01081	1			100K 5% 1/4W Carbon Film	RC07GF104J	
R222	01-01061	1			10K 5% 1/4W Carbon Film	RC07GF103J	

REF.DES.	STOCK #	QUANTITY	DESCRIPTION	MANUFACTURING/PURCHASING DATA	ALTERNATE
R223	01-10111	1	1.24M 1% 50ppm/C 1/4W Metal Film	RN60C1244F	
R224	01-10111	1	1.24M 1% 50ppm/C 1/4W Metal Film	RN60C1244F	
R225	01-01081	1	100K 5% 1/4W Carbon Film	RC07GF104J	
R226	01-01081	1	100K 5% 1/4W Carbon Film	RC07GF104J	
R227	01-01041	1	1K 5% 1/4W Carbon Film	RC07GF102J	
R228	01-50028	1	50K Top Adjust	Beckman 68WR50K	
R230	01-01061	1	10K 5% 1/4W Carbon Film	RC07GF103J	
R231	01-01061	1	10K 5% 1/4W Carbon Film	RC07GF103J	
R302	01-01074	1	51K 5% 1/4W Carbon Film	RC07GF513J	
R303	01-01083	1	150K 5% 1/4W Carbon Film	RC07GF154J	
R304	01-01061	1	10K 5% 1/4W Carbon Film	RC07GF103J	
R305	01-10111	1	1.24M 1% 50ppm/C 1/4W Metal Film	RN60C1244F	
R306	01-10111	1	1.24M 1% 50ppm/C 1/4W Metal Film	RN60C1244F	
R307	01-01081	1	100K 5% 1/4W Carbon Film	RC07GF104J	
R308	01-01081	1	100K 5% 1/4W Carbon Film	RC07GF104J	
R309	01-01041	1	1K 5% 1/4W Carbon Film	RC07GF102J	
R310	01-50028	1	50K Top Adjust	Beckman 68WR50K	
R311	01-01081	1	100K 5% 1/4W Carbon Film	RC07GF104J	
R312	01-01081	1	100K 5% 1/4W Carbon Film	RC07GF104J	
R313	01-01061	1	10K 5% 1/4W Carbon Film	RC07GF103J	
R314	01-10111	1	1.24M 1% 50ppm/C 1/4W Metal Film	RN60C1244F	
R315	01-10111	1	1.24M 1% 50ppm/C 1/4W Metal Film	RN60C1244F	
R316	01-01081	1	100K 5% 1/4W Carbon Film	RC07GF104J	
R317	01-01081	1	100K 5% 1/4W Carbon Film	RC07GF104J	
R318	01-01041	1	1K 5% 1/4W Carbon Film	RC07GF102J	
R319	01-50028	1	50K Top Adjust	Beckman 68WR50K	
R320	01-01081	1	100K 5% 1/4W Carbon Film	RC07GF104J	
R322	01-01061	1	10K 5% 1/4W Carbon Film	RC07GF103J	
R323	01-10111	1	1.24M 1% 50ppm/C 1/4W Metal Film	RN60C1244F	
R324	01-10111	1	1.24M 1% 50ppm/C 1/4W Metal Film	RN60C1244F	
R325	01-01081	1	100K 5% 1/4W Carbon Film	RC07GF104J	
R326	01-01081	1	100K 5% 1/4W Carbon Film	RC07GF104J	
R327	01-01041	1	1K 5% 1/4W Carbon Film	RC07GF102J	
R328	01-50028	1	50K Top Adjust	Beckman 68WR50K	
R330	01-01061	1	10K 5% 1/4W Carbon Film	RC07GF103J	
R331	01-01061	1	10K 5% 1/4W Carbon Film	RC07GF103J	
T1	04-20039	1	Power XFMR	Signal,DST-4-36	
T2	04-20040	1	Power XFMR	Signal,DPC-12-2000	
T101	04-20039	1	Power XFMR	Signal,DST-4-36	
T201	04-20039	1	Power XFMR	Signal,DST-4-36	
T301	04-20039	1	Power XFMR	Signal,DST-4-36	
XIC3	05-10025	1	Heatsink, TO3, 1" high	Thermalloy 6003B-2	

REF.DES.	STOCK #	QUANTITY			DESCRIPTION	MANUFACTURING/PURCHASING DATA	ALTERNATE
		A	T	N			
1	05-10213	3			Card guide, snap-in, 4.125 lg., 0.47 wide	Unitrack RAD4125	
2	05-10314	6			Standoff, snap-in, 3/8 lg #6 Thread	Smith 3929	
3	05-10488	1			Shorting plug, .1 spacing, gold	Molex 15-29-1024	
4	80-03530	8			30awg Wire, Green Kynar		
A1	04-30075	1			2300 Display Board	DWG 2300-702	
C1	02-60002	1			0.1uF 250V Mylar	Illinois 104MSR250K	
C2	02-50000	1			0.22uF 10% 50V Polystyrene	IMB PA2A224K	
C3	02-30000	1			4.7uF 16V Tantalum Bead	TAP475K016SP	
C4	02-30001	1			10uF 25V Tantalum Bead	AVX TAP106K025SP	
C5	02-30001	1			10uF 25V Tantalum Bead	AVX TAP106K025SP	
C9	02-10006	1			0.01uF 50V Ceramic disc	Illinois 103GR050-Z	
C10	02-10014	1			0.1uF 50V Ceramic Disc	AVX SR205E104MAA00	
C11	02-60002	1			0.1uF 250V Mylar	Illinois 104MSR250K	
C12	02-50000	1			0.22uF 10% 50V Polystyrene	IMB PA2A224K	
C13	02-30000	1			4.7uF 16V Tantalum Bead	TAP475K016SP	
C14	02-30001	1			10uF 25V Tantalum Bead	AVX TAP106K025SP	
C15	02-30001	1			10uF 25V Tantalum Bead	AVX TAP106K025SP	
C16	02-10006	1			0.01uF 50V Ceramic disc	Illinois 103GR050-Z	
C17	02-10014	1			0.1uF 50V Ceramic Disc	AVX SR205E104MAA00	
C18	02-50000	1			0.22uF 10% 50V Polystyrene	IMB PA2A224K	
C19	02-10006	1			0.01uF 50V Ceramic disc	Illinois 103GR050-Z	
C20	02-10007	1			330p 1000V Ceramic disc	SPRAGUE 56AT33	
C21	02-30000	1			4.7uF 16V Tantalum Bead	TAP475K016SP	
C22	02-30001	1			10uF 25V Tantalum Bead	AVX TAP106K025SP	
C23	02-30001	1			10uF 25V Tantalum Bead	AVX TAP106K025SP	
C24	02-10006	1			0.01uF 50V Ceramic disc	Illinois 103GR050-Z	
C25	02-10014	1			0.1uF 50V Ceramic Disc	AVX SR205E104MAA00	
C26	02-60002	1			0.1uF 250V Mylar	Illinois 104MSR250K	
C34	02-30001	1			10uF 25V Tantalum Bead	AVX TAP106K025SP	
C35	02-10004	1			0.02uF 500V Ceramic disc	SPRAGUE 140CD500Z9-203Z	
C36	02-10004	1			0.02uF 500V Ceramic disc	SPRAGUE 140CD500Z9-203Z	
C37	02-10004	1			0.02uF 500V Ceramic disc	SPRAGUE 140CD500Z9-203Z	
C38	02-10004	1			0.02uF 500V Ceramic disc	SPRAGUE 140CD500Z9-203Z	
C39	02-10004	1			0.02uF 500V Ceramic disc	SPRAGUE 140CD500Z9-203Z	
C40	02-10004	1			0.02uF 500V Ceramic disc	SPRAGUE 140CD500Z9-203Z	
C41	02-30006	1			0.47uF 35V Tantalum Bead	TAP474K035SP	
C43	02-10014	1			0.1uF 50V Ceramic Disc	AVX SR205E104MAA00	
CR1	03-20000	1			Diode, general purpose	1N4148 or 1N914	
CR2	03-20000	1			Diode, general purpose	1N4148 or 1N914	
CR3	03-20000	1			Diode, general purpose	1N4148 or 1N914	
CR4	03-20000	1			Diode, general purpose	1N4148 or 1N914	
CR5	03-20000	1			Diode, general purpose	1N4148 or 1N914	
CR6	03-20000	1			Diode, general purpose	1N4148 or 1N914	
CR7	03-20000	1			Diode, general purpose	1N4148 or 1N914	
CR8	03-20000	1			Diode, general purpose	1N4148 or 1N914	
CR9	03-20000	1			Diode, general purpose	1N4148 or 1N914	
CR10	03-20000	1			Diode, general purpose	1N4148 or 1N914	
CR11	03-20000	1			Diode, general purpose	1N4148 or 1N914	
CR12	03-20000	1			Diode, general purpose	1N4148 or 1N914	
CR13	03-20000	1			Diode, general purpose	1N4148 or 1N914	
CR14	03-20000	1			Diode, general purpose	1N4148 or 1N914	

REF.DES.	STOCK #	QUANTITY			DESCRIPTION	MANUFACTURING/PURCHASING DATA	ALTERNATE
		A	T	N			
CR15	03-20000	1			Diode, general purpose	1N4148 or 1N914	
CR16	03-20000	1			Diode, general purpose	1N4148 or 1N914	
CR17	03-20000	1			Diode, general purpose	1N4148 or 1N914	
CR18	03-20000	1			Diode, general purpose	1N4148 or 1N914	
CR19	03-20000	1			Diode, general purpose	1N4148 or 1N914	
CR20	03-20000	1			Diode, general purpose	1N4148 or 1N914	
CR21	03-20000	1			Diode, general purpose	1N4148 or 1N914	
CR22	03-20000	1			Diode, general purpose	1N4148 or 1N914	
CR23	03-20000	1			Diode, general purpose	1N4148 or 1N914	
CR24	03-20000	1			Diode, general purpose	1N4148 or 1N914	
DS1	05-01020	1			Display,LED,Red,+/-1	HP 5082-7656, Bin C, D or E	
DS2	05-01010	1			Display,LED,Red,0-9	HP 5082-7650 Bin C, D or E	
DS3	05-01010	1			Display,LED,Red,0-9	HP 5082-7650 Bin C, D or E	
DS4	05-01010	1			Display,LED,Red,0-9	HP 5082-7650 Bin C, D or E	
DS5	05-01010	1			Display,LED,Red,0-9	HP 5082-7650 Bin C, D or E	
DS6	05-01020	1			Display,LED,Red,+/-1	HP 5082-7656, Bin C, D or E	
DS7	05-01010	1			Display,LED,Red,0-9	HP 5082-7650 Bin C, D or E	
DS8	05-01010	1			Display,LED,Red,0-9	HP 5082-7650 Bin C, D or E	
DS9	05-01010	1			Display,LED,Red,0-9	HP 5082-7650 Bin C, D or E	
DS10	05-01010	1			Display,LED,Red,0-9	HP 5082-7650 Bin C, D or E	
DS11	05-01020	1			Display,LED,Red,+/-1	HP 5082-7656, Bin C, D or E	
DS12	05-01010	1			Display,LED,Red,0-9	HP 5082-7650 Bin C, D or E	
DS13	05-01010	1			Display,LED,Red,0-9	HP 5082-7650 Bin C, D or E	
DS14	05-01010	1			Display,LED,Red,0-9	HP 5082-7650 Bin C, D or E	
DS15	05-01010	1			Display,LED,Red,0-9	HP 5082-7650 Bin C, D or E	
DS16	05-01005	1			Single LED,Red,Small	Hewlett Packard,HLMP1000	
DS17	05-01005	1			Single LED,Red,Small	Hewlett Packard,HLMP1000	
DS18	05-01005	1			Single LED,Red,Small	Hewlett Packard,HLMP1000	
DS19	05-01005	1			Single LED,Red,Small	Hewlett Packard,HLMP1000	
DS20	05-01005	1			Single LED,Red,Small	Hewlett Packard,HLMP1000	
DS21	05-01005	1			Single LED,Red,Small	Hewlett Packard,HLMP1000	
DS22	05-01005	1			Single LED,Red,Small	Hewlett Packard,HLMP1000	
DS23	05-01005	1			Single LED,Red,Small	Hewlett Packard,HLMP1000	
DS24	05-01005	1			Single LED,Red,Small	Hewlett Packard,HLMP1000	
IC1	03-30106	1			BCD to 7-Segment decoder/driver	74LS47N	
IC2	03-30113	1			A to D Convertor (analog portion)	Intersil ICL8068ACPD or equiv.	
IC3	03-30114	1			A to D convertor (digital portion)	Intersil ICL71C03ACPI or equiv.	
IC4	05-02007	1			Programmable Osc.,8.3Hz-1MHz	Statek,PX01000KHzA	
IC5	03-30164	1			Hex buffer open collector (30V)	7407	
IC6	03-30209	1			16 Key Encoder (CMOS)	74C922	
IC7	03-30052	1			Quad 2-to-1 Multiplexer (CMOS)	74C157N or 40257BE	
IC8	03-30210	1			1 of 10 Decoder	74145N	
IC9	03-30164	1			Hex buffer open collector (30V)	7407	
IC10	03-30106	1			BCD to 7-Segment decoder/driver	74LS47N	
IC11	03-30113	1			A to D Converter (analog portion)	Intersil ICL8068ACPD or equiv.	
IC12	03-30114	1			A to D convertor (digital portion)	Intersil ICL71C03ACPI or equiv.	
IC13	03-50034	1			2300 Family IC13	Made from 03-30082	
IC14	03-30209	1			16 Key Encoder (CMOS)	74C922	
IC15	03-30052	1			Quad 2-to-1 Multiplexer (CMOS)	74C157N or 40257BE	
IC16	03-30210	1			1 of 10 Decoder	74145N	
IC17	03-30106	1			BCD to 7-Segment decoder/driver	74LS47N	



REF.DES.	STOCK #	QUANTITY			DESCRIPTION	MANUFACTURING/PURCHASING DATA	ALTERNATE
		A	T	N			
IC18	03-30113		1		A to D Convertor (analog portion)	Intersil ICL8068ACPD or equiv.	
IC19	03-30114		1		A to D convertor (digital portion)	Intersil ICL71C03ACPI or equiv.	
IC20	03-50014		1		2300 IC20 (Watts range decoder)	Made from 03-30154	
IC21	03-30173	1			Hex inverter open collector (30V)	7406	
IC22	03-30209	1			16 Key Encoder (CMOS)	74C922	
IC23	03-30052	1			Quad 2-to-1 Multiplexor (CMOS)	74C157N or 40257BE	
IC24	03-30210	1			1 of 10 Decoder	74145N	
IC25	03-30383	1			Dual D-Type flip flop (HCMOS)	74HC74N	
J1	05-10294	1			Socket, dil, 20 pin	Burndy DILB20P-108	
J2	05-10294	1			Socket, dil, 20 pin	Burndy DILB20P-108	
J3	05-10294	1			Socket, dil, 20 pin	Burndy DILB20P-108	
J4	05-10294	1			Socket, dil, 20 pin	Burndy DILB20P-108	
J5	05-10310	2			Socket, right angle, 10 way, gold	Molex 22-16-2101	
J6	05-10310	2			Socket, right angle, 10 way, gold	Molex 22-16-2101	
JP1	05-10529	1			Header, 3 pin, .56 lg, gold, .10 sp.	Molex 22-10-2031	
K1	05-03012	1			Relay, Reed, 5V Coil, DIL, Form A	CP Clare: PRMA 1A 05	
K2	05-03012	1			Relay, Reed, 5V Coil, DIL, Form A	CP Clare: PRMA 1A 05	
K3	05-03012	1			Relay, Reed, 5V Coil, DIL, Form A	CP Clare: PRMA 1A 05	
R1	01-01021	1			100 5% 1/4W Carbon Film	RC07GF101J	
R2	01-01021	1			100 5% 1/4W Carbon Film	RC07GF101J	
R3	01-01073	1			47K 5% 1/4W Carbon Film	RC07GF473J	
R4	01-01061	1			10K 5% 1/4W Carbon Film	RC07GF103J	
R5	01-01081	1			100K 5% 1/4W Carbon Film	RC07GF104J	
R6	01-01070	1			33K 5% 1/4W Carbon Film	RC07GF333J	
R7	01-01086	1			220K 5% 1/4W Carbon Film	RC07GF224J	
R8	01-10078	1			2K 1% 50ppm/C 1/4W Metal Film	RN60C2001F	
R9	01-50025	1			100 End Adjust	Beckman 89PR100ohm	
R16	01-01030	1			330 5% 1/4W Carbon Film	RC07GF331J	
R17	01-01030	1			330 5% 1/4W Carbon Film	RC07GF331J	
R18	01-01030	1			330 5% 1/4W Carbon Film	RC07GF331J	
R19	01-01030	1			330 5% 1/4W Carbon Film	RC07GF331J	
R20	01-01030	1			330 5% 1/4W Carbon Film	RC07GF331J	
R21	01-01030	1			330 5% 1/4W Carbon Film	RC07GF331J	
R22	01-01030	1			330 5% 1/4W Carbon Film	RC07GF331J	
R23	01-01061	1			10K 5% 1/4W Carbon Film	RC07GF103J	
R24	01-01021	1			100 5% 1/4W Carbon Film	RC07GF101J	
R25	01-01021	1			100 5% 1/4W Carbon Film	RC07GF101J	
R26	01-01021	1			100 5% 1/4W Carbon Film	RC07GF101J	
R27	01-01061	1			10K 5% 1/4W Carbon Film	RC07GF103J	
R28	01-01073	1			47K 5% 1/4W Carbon Film	RC07GF473J	
R29	01-01061	1			10K 5% 1/4W Carbon Film	RC07GF103J	
R30	01-01081	1			100K 5% 1/4W Carbon Film	RC07GF104J	
R31	01-01070	1			33K 5% 1/4W Carbon Film	RC07GF333J	
R32	01-01086	1			220K 5% 1/4W Carbon Film	RC07GF224J	
R33	01-10078	1			2K 1% 50ppm/C 1/4W Metal Film	RN60C2001F	
R34	01-50025	1			100 End Adjust	Beckman 89PR100ohm	
R35	01-01030	1			330 5% 1/4W Carbon Film	RC07GF331J	
R36	01-01021	1			100 5% 1/4W Carbon Film	RC07GF101J	
R37	01-01021	1			100 5% 1/4W Carbon Film	RC07GF101J	
R38	01-01021	1			100 5% 1/4W Carbon Film	RC07GF101J	
R39	01-01021	1			100 5% 1/4W Carbon Film	RC07GF101J	

REF. DES.	STOCK #	QUANTITY			DESCRIPTION	MANUFACTURING/PURCHASING DATA	ALTERNATE
		A	T	N			
R40	01-01053	1			4.7K 5% 1/4W Carbon Film	RC07GF472J	
R41	01-01073	1			47K 5% 1/4W Carbon Film	RC07GF473J	
R42	01-01061	1			10K 5% 1/4W Carbon Film	RC07GF103J	
R43	01-01081	1			100K 5% 1/4W Carbon Film	RC07GF104J	
R44	01-01070	1			33K 5% 1/4W Carbon Film	RC07GF333J	
R45	01-01086	1			220K 5% 1/4W Carbon Film	RC07GF224J	
R46	01-10026	1			374 1% 50ppm/C 1/4W Metal Film	RN60C3740F	
R47	01-10000	1			FACTORY SELECT VALUE (1%)	RN60CXXX	
R48	01-50025	1			100 End Adjust	Beckman 89PR100ohm	
R49	01-10078	1			2K 1% 50ppm/C 1/4W Metal Film	RN60C2001F	
R51	01-01030	1			330 5% 1/4W Carbon Film	RC07GF331J	
R52	01-01030	1			330 5% 1/4W Carbon Film	RC07GF331J	
R53	01-01061	1			10K 5% 1/4W Carbon Film	RC07GF103J	
R54	01-01081	1			100K 5% 1/4W Carbon Film	RC07GF104J	
R55	01-01030	1			330 5% 1/4W Carbon Film	RC07GF331J	
R58	01-01068	1			27K 5% 1/4W Carbon Film	RC07GF273J	
R59	01-01061	1			10K 5% 1/4W Carbon Film	RC07GF103J	
R60	01-01026	1			220 5% 1/4W Carbon Film	RC07GF221J	
R61	01-01026	1			220 5% 1/4W Carbon Film	RC07GF221J	
R62	01-01061	1			10K 5% 1/4W Carbon Film	RC07GF103J	
R63	01-01061	1			10K 5% 1/4W Carbon Film	RC07GF103J	
R64	01-01043	1			1.5K 5% 1/4W Carbon Film	RC07GF152J	
R65	01-01043	1			1.5K 5% 1/4W Carbon Film	RC07GF152J	
RN1	01-40002	1			8 x 100 Network	A-B 316B-101	
RN2	01-40003	1			15 x 10K Network	A-B 316A-103	
RN3	01-40002	1			8 x 100 Network	A-B 316B-101	
RN4	01-40002	1			8 x 100 Network	A-B 316B-101	
S1	05-03052	1			Switch, SPDT, Momentary, Black w/Red LED	Schadow, SEAU0A00105R	
S2	05-03052	1			Switch, SPDT, Momentary, Black w/Red LED	Schadow, SEAU0A00105R	
S3	05-03052	1			Switch, SPDT, Momentary, Black w/Red LED	Schadow, SEAU0A00105R	
S4	05-03052	1			Switch, SPDT, Momentary, Black w/Red LED	Schadow, SEAU0A00105R	
S5	05-03052	1			Switch, SPDT, Momentary, Black w/Red LED	Schadow, SEAU0A00105R	
S6	05-03052	1			Switch, SPDT, Momentary, Black w/Red LED	Schadow, SEAU0A00105R	
S7	05-03052	1			Switch, SPDT, Momentary, Black w/Red LED	Schadow, SEAU0A00105R	
S8	05-03052	1			Switch, SPDT, Momentary, Black w/Red LED	Schadow, SEAU0A00105R	
S9	05-03052	1			Switch, SPDT, Momentary, Black w/Red LED	Schadow, SEAU0A00105R	
S10	05-03052	1			Switch, SPDT, Momentary, Black w/Red LED	Schadow, SEAU0A00105R	
S11	05-03052	1			Switch, SPDT, Momentary, Black w/Red LED	Schadow, SEAU0A00105R	
S12	05-03052	1			Switch, SPDT, Momentary, Black w/Red LED	Schadow, SEAU0A00105R	
S13	05-03052	1			Switch, SPDT, Momentary, Black w/Red LED	Schadow, SEAU0A00105R	
S14	05-03052	1			Switch, SPDT, Momentary, Black w/Red LED	Schadow, SEAU0A00105R	
S15	05-03052	1			Switch, SPDT, Momentary, Black w/Red LED	Schadow, SEAU0A00105R	
S16	05-03052	1			Switch, SPDT, Momentary, Black w/Red LED	Schadow, SEAU0A00105R	
S17	05-03052	1			Switch, SPDT, Momentary, Black w/Red LED	Schadow, SEAU0A00105R	
S18	05-03052	1			Switch, SPDT, Momentary, Black w/Red LED	Schadow, SEAU0A00105R	
S19	05-03052	1			Switch, SPDT, Momentary, Black w/Red LED	Schadow, SEAU0A00105R	
S20	05-03077	1			Switch, Push, Black, w/Red & Green LED's	Schadow, SEAU0A0106RG	
TR1	03-10013	1			NPN Transistor (TO92)	2N4401	
TR2	03-10013	1			NPN Transistor (TO92)	2N4401	
TR3	03-10013	1			NPN Transistor (TO92)	2N4401	
TR4	03-10013	1			NPN Transistor (TO92)	2N4401	

REF.DES.	STOCK #	QUANTITY			DESCRIPTION	MANUFACTURING/PURCHASING DATA	ALTERNATE
		A	T	N			
TR5	03-10013	1			NPN Transistor (TO92)	2N4401	
TR6	03-10013	1			NPN Transistor (TO92)	2N4401	
TR7	03-10013	1			NPN Transistor (TO92)	2N4401	
TR8	03-10013	1			NPN Transistor (TO92)	2N4401	
TR9	03-10013	1			NPN Transistor (TO92)	2N4401	
TR10	03-10013	1			NPN Transistor (TO92)	2N4401	
TR11	03-10013	1			NPN Transistor (TO92)	2N4401	
TR12	03-10013	1			NPN Transistor (TO92)	2N4401	
TR13	03-10010	1			PNP Transistor (TO92)	2N4402	
TR14	03-10013	1			NPN Transistor (TO92)	2N4401	
TR15	03-10013	1			NPN Transistor (TO92)	2N4401	
TR16	03-10013	1			NPN Transistor (TO92)	2N4401	
TR17	03-10013	1			NPN Transistor (TO92)	2N4401	
TR18	03-10013	1			NPN Transistor (TO92)	2N4401	
TR19	03-10013	1			NPN Transistor (TO92)	2N4401	
TR20	03-10013	1			NPN Transistor (TO92)	2N4401	
TR21	03-10013	1			NPN Transistor (TO92)	2N4401	
TR22	03-10013	1			NPN Transistor (TO92)	2N4401	
XIC2	05-10041	1			Socket, dil, 14 pin	Burndy 8514-01	
XIC3	05-10295	1			Socket, dil, 28 pin	Burndy DILB28P-108	
XIC11	05-10041	1			Socket, dil, 14 pin	Burndy 8514-01	
XIC12	05-10295	1			Socket, dil, 28 pin	Burndy DILB28P-108	
XIC13	05-10008	1			Socket, dil, 16 pin	Burndy C8516-01	
XIC18	05-10041	1			Socket, dil, 14 pin	Burndy 8514-01	
XIC19	05-10295	1			Socket, dil, 28 pin	Burndy DILB28P-108	
XIC20	05-10042	1			Socket, dil, 24 pin	TI 8524-01	

REF.DES.	STOCK #	QUANTITY			DESCRIPTION	MANUFACTURING/PURCHASING DATA
		A	T	N		
1	2300-400	1			2300 Final Assy.	Assembly 2300-400
20	04-10687	1			2300L Front Panel (screened)	DWG 2300-101 using 04-10340
IC20	03-50015	1			2300L IC20 (Watts range decoder)	Made from 03-30154
R21	01-10006	1			100K 1% 50ppm/C 1/4W Metal Film	RN60C1003F
R500	01-01021	1			100 5% 1/4W Carbon Film	RC07GF101J

DELETE THE FOLLOWING FROM PARTS LIST: 2300-600 Signal Processing Bd. Assy

R21	01-10007	1			1.0M 1% 50ppm/C 1/2W Metal Film	RN65C1004F
-----	----------	---	--	--	---------------------------------	------------

DELETE THE FOLLOWING FROM PARTS LIST: 2300-602 2300 Display Board Assy

DS22	05-01005	1			Single LED, Red, Small	Hewlett Packard, HLMP1000
IC20	03-50014	1			2300 IC20 (Watts Range Decoder)	made from 03-30154

DELETE THE FOLLOWING FROM PARTS LIST: 1000-600 488 IEEE Bd. Assy

IC6	03-50017	1			2300/1 TL-4 ROM	made from 03-30154
-----	----------	---	--	--	-----------------	--------------------

WITH OPTION TL-4 INSTALL THE FOLLOWING:

IC6	03-50016	1			2300/1L TL-4 ROM	made from 03-30154
-----	----------	---	--	--	------------------	--------------------

WITH OPTION TL-5 INSTALL THE FOLLOWING:

IC6	03-50024	1			2300/1L TL-5 ROM	made from 03-30154
-----	----------	---	--	--	------------------	--------------------

DELETE THE FOLLOWING FROM PARTS LIST: 2300-400 2300 Final Assy

20	04-10503	1			2300 Front Panel (screened)	DWG 2300-100 using 04-10340
----	----------	---	--	--	-----------------------------	-----------------------------

REF.DES.	STOCK #	QUANTITY			DESCRIPTION	MANUFACTURING/PURCHASING DATA	ALTERNATE
		A	T	N			
3	2300-600	1			2300/01 Signal Processing Board Assembly	Assembly 2300-600	
4	2301-601	1			2301 Main Board Assy.	Assembly 2301-601	
5	2301-602	1			2301 Display Board Assembly	Assembly 2301-602	
8	2301-402	1			2301 Shunt Plate Assy. (Single Phase)	Assembly 2301-402	
9	04-30098	2			Filler PCB (2301)	Keystone,1974	
10	04-10456	2			7.00" Side rail (upper right,lower left)	DWG 2300-223	
12	04-10457	2			7.00" Side rail (upper left,lower right)	DWG 2300-224	
13	04-10883	1			Aluminum Bottom Plate	DWG 2300-238	
14	04-10884	1			Aluminum Top Cover	DWG 2300-239	
15	04-10370	4			2703 Chassis Support Bar (corner block)	DWG 2703-212	
16	04-10333	3			Standard Bezel	DWG 2724-205	
17	04-10346	1			2300/2575A/4100 Main bd. support bar	DWG 2300-214	
19	04-10882	1			Aluminum Flip Lid	DWG 2300-237	
20	04-10502	1			2301 front panel (screened)	DWG 2301-100 using 04-10396	
21	04-10342	1			2300/2301 Rear panel	DWG 2300-201	
22	04-10345	2			2300 Windtunnel	DWG 2300-202	
24	04-10332	2			Standard Corner Block	DWG 2724-204	
25	04-10305	1			4300B Butch Plate	DWG 4300-213	
27	05-10350	27			Grommet, caterpillar, .18" thick	Smith 2694	
28	05-10166	1			Receptical, AC, filter	Corcom 6EF1	
34	05-10213	3			Card guide,snap-in,4.125 lg.,0.47 wide	Unitrack RAD4125	
35	05-03017	1			Slide Switch,115/230V,2Pole	Switchcraft,4625LFR	
36	05-10018	1			Fuseholder, panel mount	Littlefuse 345061	
37	05-03061	1			Switch,Power,Black,Yellow,2PDT	Schadow,ZFNE152UEE11010106B	
39	05-10317	2			Washer, nylon, shoulder, #4	Keystone 3053	
40	05-10625	1			Grommet,I.D. 5/16", O.D. 5/8"	Smith 2174	
41	05-10361	2			Foot, hard, rubber, grey	ACC.Rubber 2095W-017-GREY	
44	05-10570	1			Hole Plug,Black,.687 Dia.	Heyco,2673(Black),DP-687	
45	92-06004	7			6-32 x 1/4" Phil Truss Head S.S.		
46	04-10469	1			2300 Main bd. support bar (front end)	DWG 2300-225	
48	90-06009	2			#6-32 x 9/16" Phil Pan S.S.		
49	91-06006	8			#6-32 x 3/8" Phil Flat 82 Deg. S.S.		
50	90-06006	13			#6-32 x 3/8" Phil Pan S.S.		
51	90-06006	5			#6-32 x 3/8" Phil Pan S.S.		
52	90-04008	2			#4-40 x 1/2" Phil Pan S.S.		
53	91-06009	20			#6-32 x 9/16" Phil Flat 82 Deg. S.S.		
54	90-06004	2			#6-32 x 1/4" Phil Pan S.S.		
55	98-04001	4			#4 Split Lock Washer S.S.		
56	98-06002	23			#6 Internal Star Washer, S.S.		
57	90-06005	8			#6-32 x 5/16" Phil Pan S.S.		
58	05-10086	1			Solder lug, #6, internal star	Smith 1412-6	
59	05-10431	2			Standoff, 1/4 hex, 3/8 lg, 6-32, M-F	RAF 4532-632-SS-0	
60	97-06001	5			#6-32 Hex Nut, Small Pattern, Stainless-Steel		
61	05-10019	12			Cable tie, 4"x 1/8"	Panduit WRN-4	
62	05-10261	3			Tie-wrap block, large	Panduit ABM2S-A	
63	80-01516	18			16awg Wire, Green PVC	M16878/1-BJE-5	
64	80-01218	48			18awg Wire, Red PVC	M16878/1-BHE-2	
65	80-01018	48			18awg Wire, Black PVC	M16878/1-BHE-0	
66	80-01918	48			18awg Wire, White PVC	M16878/1-BHE-9	
67	80-01518	48			18awg Wire, Green PVC	M16878/1-BHE-5	
68	70-00008	36			1/2" Black Shrink Tubing	ANX 364-011-0500-02	

REF.DES.	STOCK #	QUANTITY	DESCRIPTION	MANUFACTURING/PURCHASING DATA	ALTERNATE
		A T N			
73	90-06007	4	#6-32 x 7/16" Phil Pan S.S.		
75	97-04001	2	#4-40 Radio Hex Nut S.S.		
77	05-04002	1	1A,Slo Blo Fuse	Littlefuse,313-001	
79	05-10310	2	Socket, right angle, 10 way, gold	Molex 22-16-2101	

REF.DES.	STOCK #	QUANTITY			DESCRIPTION	MANUFACTURING/PURCHASING DATA
		A	T	N		
3	04-30074	1			2300 Main Board	DWG 2300-701
6	05-10042	1			Socket, dil, 24 pin	TI 8524-01
7	05-10313	7			Wafer, 10 way, gold, 0.56 lg	Molex 22-10-2101
71	90-06006	2			#6-32 x 3/8" Phil Pan S.S.	
72	98-06002	2			#6 Internal Star Washer, S.S.	
73	97-06001	2			#6-32 Hex Nut, SMALL PATTERN, S.S.	
77	05-10582	1			Cable Tie 8.0"lg x .10"wide	Panduit PLT2M
C1	02-40013	1			470u 50V Aluminum	Illinois 477TTA050
C2	02-40013	1			470u 50V Aluminum	Illinois 477TTA050
C3	02-30004	1			1u 25V Tantalum Bead	Kemet T350A105K025AS
C4	02-30004	1			1u 25V Tantalum Bead	Kemet T350A105K025AS
C5	02-40012	1			15000u 16V Aluminum	Illinois 159TTA016
C6	02-30001	1			10u 25V Tantalum Bead	AVX TAP106K025SP
C7	02-10014	1			0.1u 50V Ceramic disc	AVX SR205E104MAA00
C10	02-10014	1			0.1u 50V Ceramic disc	AVX SR205E104MAA00
C13	02-10004	1			0.02u 500V Ceramic disc	SPRAGUE 140CD500Z9-203Z
C14	02-10004	1			0.02u 500V Ceramic disc	SPRAGUE 140CD500Z9-203Z
C19	02-30003	1			47u 10V Tantalum Bead	AVX TAP476M020SP
C20	02-30003	1			47u 10V Tantalum Bead	AVX TAP476M020SP
CR1	03-20002	1			Diode, rectifier, 1A, 50V	1N4001-1N4007
CR2	03-20002	1			Diode, rectifier, 1A, 50V	1N4001-1N4007
CR3	03-20002	1			Diode, rectifier, 1A, 50V	1N4001-1N4007
CR4	03-20002	1			Diode, rectifier, 1A, 50V	1N4001-1N4007
CR5	03-20049	1			Diode, Rectifier, 3A, 50v	Motorola MR500
CR6	03-20049	1			Diode, Rectifier, 3A, 50v	Motorola MR500
C101	02-40013	1			470u 50V Aluminum	Illinois 477TTA050
C102	02-40013	1			470u 50V Aluminum	Illinois 477TTA050
C103	02-30004	1			1u 25V Tantalum Bead	Kemet T350A105K025AS
C104	02-30004	1			1u 25V Tantalum Bead	Kemet T350A105K025AS
C105	02-60000	1			0.0047u 100V Mylar	
C106	02-60000	1			0.0047u 100V Mylar	
C107	02-60000	1			0.0047u 100V Mylar	
C108	02-60000	1			0.0047u 100V Mylar	
C109	02-60000	1			0.0047u 100V Mylar	
C110	02-60000	1			0.0047u 100V Mylar	
C111	02-10006	1			0.01u 50V Ceramic disc	Illinois 103GR050-Z
CR11	03-20000	1			Diode, general purpose	1N4148 or 1N914
CR12	03-20000	1			Diode, general purpose	1N4148 or 1N914
CR13	03-20000	1			Diode, general purpose	1N4148 or 1N914
CR14	03-20000	1			Diode, general purpose	1N4148 or 1N914
CR15	03-20000	1			Diode, general purpose	1N4148 or 1N914
CR16	03-20000	1			Diode, general purpose	1N4148 or 1N914
CR17	03-20007	1			Zener, reference, 6.3V, 10ppm/c, 5%	
CR18	03-20007	1			Zener, reference, 6.3V, 10ppm/c, 5%	
CR101	03-20002	1			Diode, rectifier, 1A, 50V	1N4001-1N4007
CR102	03-20002	1			Diode, rectifier, 1A, 50V	1N4001-1N4007
CR103	03-20002	1			Diode, rectifier, 1A, 50V	1N4001-1N4007
CR104	03-20002	1			Diode, rectifier, 1A, 50V	1N4001-1N4007
CR111	03-20000	1			Diode, general purpose	1N4148 or 1N914
CR112	03-20000	1			Diode, general purpose	1N4148 or 1N914

REF.DES.	STOCK #	QUANTITY			DESCRIPTION	MANUFACTURING/PURCHASING DATA
		A	T	N		
CR113	03-20000	1			Diode, general purpose	1N4148 or 1N914
CR114	03-20000	1			Diode, general purpose	1N4148 or 1N914
CR115	03-20000	1			Diode, general purpose	1N4148 or 1N914
CR116	03-20000	1			Diode, general purpose	1N4148 or 1N914
IC1	03-30036	1			Regulator,+15V,0.5A,TO202 or TO220	78M15CP or LM340T-15
IC2	03-30037	1			Regulator,-15V,0.5A,TO202 or TO220	79M15CP or LM320T-15
IC3	03-30042	1			Regulator,+5V,1.5A,TO3	7805CK or LM340K-5.0
IC4	03-30170	1			Low Noise, low drift Op-amp	
IC5	03-30203	1			8 to 1 multiplexor	
IC6	03-30203	1			8 to 1 multiplexor	
IC7	03-30203	1			8 to 1 multiplexor	
IC8	03-50008		1		2300 Family IC8	
IC9	03-30164	1			Hex buffer open collector (30V)	
IC10	03-30164	1			Hex buffer open collector (30V)	
IC11	03-30205	1			Dual Monostable (CMOS)	
IC14	03-30326	1			Dual General Purpose Op Amp	
IC101	03-30036	1			Regulator,+15V,0.5A,TO202 or TO220	
IC102	03-30037	1			Regulator,-15V,0.5A,TO202 or TO220	
IC103	03-30133	1			Quad general purpose comparator	
IC104	03-30090	1			General Purpose JFET Op-Amp	
IC105	03-30090	1			General Purpose JFET Op-Amp	
IC106	03-30090	1			General Purpose JFET Op-Amp	
R1	01-01077	1			68K 5% 1/4W Carbon Film	RC07GF683J
R2	01-01077	1			68K 5% 1/4W Carbon Film	RC07GF683J
R3	01-01077	1			68K 5% 1/4W Carbon Film	RC07GF683J
R4	01-01077	1			68K 5% 1/4W Carbon Film	RC07GF683J
R5	01-10178	1			10K 0.1% 25ppm/C 1/8W Metal Film	PRP 1/8W - 10K - 0.1% - 25PPM
R9	01-10178	1			10K 0.1% 25ppm/C 1/8W Metal Film	PRP 1/8W - 10K - 0.1% - 25PPM
R10	01-10017	1			9.09K 1% 25ppm/C 1/4W Metal Film	RN60C9091F
R11	01-50014	1			100 Top Adjust	Beckman 68WR100ohm
R12	01-10110	1			1.13K 1% 50ppm/C 1/4W Metal Film	RN60C1131F
R13	01-50033	1			50 Top Adjust	Beckman 68WR50ohm
R14	01-10014	1			698 1% 50ppm/C 1/4W Metal Film	RN60C6980F
R15	01-50033	1			50 Top Adjust	Beckman 68WR50ohm
R16	01-10157	1			475 1% 50ppm/C 1/4W Metal Film	RN60C4750F
R17	01-10017	1			9.09K 1% 50ppm/C 1/4W Metal Film	RN60C9091F
R18	01-50037	1			200 Top Adjust	Beckman 68WR200ohm
R19	01-10053	1			2.43K 1% 50ppm/C 1/4W Metal Film	RN60C2431F
R20	01-50014	1			100 Top Adjust	Beckman 68WR100ohm
R21	01-10167	1			200 1% 50ppm/C 1/4W Metal Film	RN60C2000F
R22	01-50014	1			100 Top Adjust	Beckman 68WR100ohm
R23	01-10172	1			511 1% 50ppm/C 1/4W Metal Film	RN60C5110F
R24	01-50033	1			50 Top Adjust	Beckman 68WR50ohm
R25	01-10133	1			845 1% 50ppm/C 1/4W Metal Film	RN60C8450F
R26	01-10112	1			2.80K 1% 50ppm/C 1/4W Metal Film	RN60C2801F
R27	01-50037	1			200 Top Adjust	Beckman 68WR200ohm
R28	01-10070	1			649 1% 50ppm/C 1/4W Metal Film	RN60C6490F
R29	01-50037	1			200 Top Adjust	Beckman 68WR200ohm
R30	01-10173	1			365 1% 50ppm/C 1/4W Metal Film	RN60C3650F
R31	01-50037	1			200 Top Adjust	Beckman 68WR200ohm
R32	01-10021	1			604 1% 50ppm/C 1/4W Metal Film	RN60C6040F



REF.DES.	STOCK #	QUANTITY			DESCRIPTION	MANUFACTURING/PURCHASING DATA
		A	T	N		
R33	01-50014	1			100 Top Adjust	Beckman 68WR100ohm
R34	01-10175	1			324 1% 50ppm/C 1/4W Metal Film	RN60C3240F
R35	01-50014	1			100 Top Adjust	Beckman 68WR100ohm
R36	01-10138	1			182 1% 50ppm/C 1/4W Metal Film	RN60C1820F
R37	01-50014	1			100 Top Adjust	Beckman 68WR100ohm
R38	01-10172	1			511 1% 50ppm/C 1/4W Metal Film	RN60C5110F
R39	01-50033	1			50 Top Adjust	Beckman 68WR50ohm
R40	01-10051	1			100 1% 50ppm/C 1/4W Metal Film	RN60C1000F
R41	01-50033	1			50 Top Adjust	Beckman 68WR50ohm
R42	01-10014	1			698 1% 50ppm/C 1/4W Metal Film	RN60C6980F
R44	01-01061	1			10K 5% 1/4W Carbon Film	RC07GF103J
R45	01-01061	1			10K 5% 1/4W Carbon Film	RC07GF103J
R53	01-01045	1			2K 5% 1/4W Carbon Film	RC07GF202J
R54	01-01045	1			2K 5% 1/4W Carbon Film	RC07GF202J
R55	01-01081	1			100K 5% 1/4W Carbon Film	RC07GF104J
R56	01-01083	1			150K 5% 1/4W Carbon Film	RC07GF154J
R57	01-01083	1			150K 5% 1/4W Carbon Film	RC07GF154J
R58	01-01081	1			100K 5% 1/4W Carbon Film	RC07GF104J
R102	01-01074	1			51K 5% 1/4W Carbon Film	RC07GF513J
R103	01-01083	1			150K 5% 1/4W Carbon Film	RC07GF154J
R104	01-01061	1			10K 5% 1/4W Carbon Film	RC07GF103J
R105	01-10111	1			1.24M 1% 50ppm/C 1/4W Metal Film	RN60C1244F
R106	01-10111	1			1.24M 1% 50ppm/C 1/4W Metal Film	RN60C1244F
R107	01-01081	1			100K 5% 1/4W Carbon Film	RC07GF104J
R108	01-01081	1			100K 5% 1/4W Carbon Film	RC07GF104J
R109	01-01041	1			1K 5% 1/4W Carbon Film	RC07GF102J
R110	01-50028	1			50K Top Adjust	Beckman 68WR50K
R111	01-01081	1			100K 5% 1/4W Carbon Film	RC07GF104J
R112	01-01081	1			100K 5% 1/4W Carbon Film	RC07GF104J
R113	01-01061	1			10K 5% 1/4W Carbon Film	RC07GF103J
R114	01-10111	1			1.24M 1% 50ppm/C 1/4W Metal Film	RN60C1244F
R115	01-10111	1			1.24M 1% 50ppm/C 1/4W Metal Film	RN60C1244F
R116	01-01081	1			100K 5% 1/4W Carbon Film	RC07GF104J
R117	01-01081	1			100K 5% 1/4W Carbon Film	RC07GF104J
R118	01-01041	1			1K 5% 1/4W Carbon Film	RC07GF102J
R119	01-50028	1			50K Top Adjust	Beckman 68WR50K
R120	01-01081	1			100K 5% 1/4W Carbon Film	RC07GF104J
R122	01-01061	1			10K 5% 1/4W Carbon Film	RC07GF103J
R123	01-10111	1			1.24M 1% 50ppm/C 1/4W Metal Film	RN60C1244F
R124	01-10111	1			1.24M 1% 50ppm/C 1/4W Metal Film	RN60C1244F
R125	01-01081	1			100K 5% 1/4W Carbon Film	RC07GF104J
R126	01-01081	1			100K 5% 1/4W Carbon Film	RC07GF104J
R127	01-01041	1			1K 5% 1/4W Carbon Film	RC07GF102J
R128	01-50028	1			50K Top Adjust	Beckman 68WR50K
R130	01-01061	1			10K 5% 1/4W Carbon Film	RC07GF103J
R131	01-01061	1			10K 5% 1/4W Carbon Film	RC07GF103J
T1	04-20039	1			Power XFMR	Signal,DST-4-36
T2	04-20040	1			Power XFMR	Signal,DPC-12-2000
T101	04-20039	1			Power XFMR	Signal,DST-4-36
XIC3	05-10025	1			Heatsink, T03, 1" high	Thermalloy 6003B-2

REF.DES.	STOCK #	QUANTITY	DESCRIPTION	MANUFACTURING/PURCHASING DATA	ALTERNATE
1	05-10213	3	Card guide,snap-in,4.125 lg.,0.47 wide	Unitrack RAD4125	
2	05-10314	6	Standoff, snap-in, 3/8 lg #6 Thread	Smith 3929	
4	80-03530	10	30awg Wire, Green Kynar		
A1	04-30075	1	2300 Display Board	DWG 2300-702	
C1	02-60002	1	0.1uF 250V Mylar	Illinois 104MSR250K	
C2	02-50000	1	0.22uF 10% 50V Polystyrene	IMB PA2A224K	
C3	02-30000	1	4.7uF 16V Tantalum Bead	TAP475K016SP	
C4	02-30001	1	10uF 25V Tantalum Bead	AVX TAP106K025SP	
C5	02-30001	1	10uF 25V Tantalum Bead	AVX TAP106K025SP	
C9	02-10006	1	0.01uF 50V Ceramic disc	Illinois 103GR050-Z	
C10	02-10014	1	0.1uF 50V Ceramic Disc	AVX SR205E104MAA00	
C11	02-60002	1	0.1uF 250V Mylar	Illinois 104MSR250K	
C12	02-50000	1	0.22uF 10% 50V Polystyrene	IMB PA2A224K	
C13	02-30000	1	4.7uF 16V Tantalum Bead	TAP475K016SP	
C14	02-30001	1	10uF 25V Tantalum Bead	AVX TAP106K025SP	
C15	02-30001	1	10uF 25V Tantalum Bead	AVX TAP106K025SP	
C16	02-10006	1	0.01uF 50V Ceramic disc	Illinois 103GR050-Z	
C17	02-10014	1	0.1uF 50V Ceramic Disc	AVX SR205E104MAA00	
C18	02-50000	1	0.22uF 10% 50V Polystyrene	IMB PA2A224K	
C19	02-10006	1	0.01uF 50V Ceramic disc	Illinois 103GR050-Z	
C20	02-10007	1	330p 1000V Ceramic disc	SPRAGUE 56AT33	
C21	02-30000	1	4.7uF 16V Tantalum Bead	TAP475K016SP	
C22	02-30001	1	10uF 25V Tantalum Bead	AVX TAP106K025SP	
C23	02-30001	1	10uF 25V Tantalum Bead	AVX TAP106K025SP	
C26	02-60002	1	0.1uF 250V Mylar	Illinois 104MSR250K	
C34	02-30001	1	10uF 25V Tantalum Bead	AVX TAP106K025SP	
C35	02-10004	1	0.02uF 500V Ceramic disc	SPRAGUE 140CD500Z9-203Z	
C36	02-10004	1	0.02uF 500V Ceramic disc	SPRAGUE 140CD500Z9-203Z	
C37	02-10004	1	0.02uF 500V Ceramic disc	SPRAGUE 140CD500Z9-203Z	
C38	02-10004	1	0.02uF 500V Ceramic disc	SPRAGUE 140CD500Z9-203Z	
C39	02-10004	1	0.02uF 500V Ceramic disc	SPRAGUE 140CD500Z9-203Z	
C40	02-10004	1	0.02uF 500V Ceramic disc	SPRAGUE 140CD500Z9-203Z	
CR1	03-20000	1	Diode, general purpose	1N4148 or 1N914	
CR2	03-20000	1	Diode, general purpose	1N4148 or 1N914	
CR3	03-20000	1	Diode, general purpose	1N4148 or 1N914	
CR4	03-20000	1	Diode, general purpose	1N4148 or 1N914	
CR5	03-20000	1	Diode, general purpose	1N4148 or 1N914	
CR6	03-20000	1	Diode, general purpose	1N4148 or 1N914	
CR7	03-20000	1	Diode, general purpose	1N4148 or 1N914	
CR8	03-20000	1	Diode, general purpose	1N4148 or 1N914	
CR9	03-20000	1	Diode, general purpose	1N4148 or 1N914	
CR10	03-20000	1	Diode, general purpose	1N4148 or 1N914	
CR11	03-20000	1	Diode, general purpose	1N4148 or 1N914	
CR12	03-20000	1	Diode, general purpose	1N4148 or 1N914	
CR13	03-20000	1	Diode, general purpose	1N4148 or 1N914	
CR24	03-20000	1	Diode, general purpose	1N4148 or 1N914	
DS1	05-01020	1	Display,LED,Red,+/-1	HP 5082-7656, Bin C, D or E	
DS2	05-01010	1	Display,LED,Red,0-9	HP 5082-7650 Bin C, D or E	
DS3	05-01010	1	Display,LED,Red,0-9	HP 5082-7650 Bin C, D or E	
DS4	05-01010	1	Display,LED,Red,0-9	HP 5082-7650 Bin C, D or E	

REF.DES.	STOCK #	QUANTITY			DESCRIPTION	MANUFACTURING/PURCHASING DATA	ALTERNATE
		A	T	N			
DS5	05-01010	1			Display,LED,Red,0-9	HP 5082-7650 Bin C, D or E	
DS6	05-01020	1			Display,LED,Red,+/-1	HP 5082-7656, Bin C, D or E	
DS7	05-01010	1			Display,LED,Red,0-9	HP 5082-7650 Bin C, D or E	
DS8	05-01010	1			Display,LED,Red,0-9	HP 5082-7650 Bin C, D or E	
DS9	05-01010	1			Display,LED,Red,0-9	HP 5082-7650 Bin C, D or E	
DS10	05-01010	1			Display,LED,Red,0-9	HP 5082-7650 Bin C, D or E	
DS11	05-01020	1			Display,LED,Red,+/-1	HP 5082-7656, Bin C, D or E	
DS12	05-01010	1			Display,LED,Red,0-9	HP 5082-7650 Bin C, D or E	
DS13	05-01010	1			Display,LED,Red,0-9	HP 5082-7650 Bin C, D or E	
DS14	05-01010	1			Display,LED,Red,0-9	HP 5082-7650 Bin C, D or E	
DS15	05-01010	1			Display,LED,Red,0-9	HP 5082-7650 Bin C, D or E	
DS16	05-01005	1			Single LED,Red,Small	Hewlett Packard,HLMP1000	
DS19	05-01005	1			Single LED,Red,Small	Hewlett Packard,HLMP1000	
DS22	05-01005	1			Single LED,Red,Small	Hewlett Packard,HLMP1000	
DS23	05-01005	1			Single LED,Red,Small	Hewlett Packard,HLMP1000	
DS24	05-01005	1			Single LED,Red,Small	Hewlett Packard,HLMP1000	
IC1	03-30106	1			BCD to 7-Segment decoder/driver	74LS47N	
IC2	03-30113	1			A to D Convertor (analog portion)	Intersil ICL8068ACPD or equiv.	
IC3	03-30114	1			A to D convertor (digital portion)	Intersil ICL71C03ACPI or equiv.	
IC4	05-02007	1			Programmable Osc.,8.3Hz-1MHz	Statek,PX01000KHZA	
IC5	03-30164	1			Hex buffer open collector (30V)	7407	
IC6	03-30209	1			16 Key Encoder (CMOS)	74C922	
IC7	03-30052	1			Quad 2-to-1 Multiplexor (CMOS)	74C157N or 40257BE	
IC8	03-30210	1			1 of 10 Decoder	74145N	
IC9	03-30164	1			Hex buffer open collector (30V)	7407	
IC10	03-30106	1			BCD to 7-Segment decoder/driver	74LS47N	
IC11	03-30113	1			A to D Convertor (analog portion)	Intersil ICL8068ACPD or equiv.	
IC12	03-30114	1			A to D convertor (digital portion)	Intersil ICL71C03ACPI or equiv.	
IC13	03-50034	1			2300 Family IC13	Made from 03-30082	
IC14	03-30209	1			16 Key Encoder (CMOS)	74C922	
IC15	03-30052	1			Quad 2-to-1 Multiplexor (CMOS)	74C157N or 40257BE	
IC16	03-30210	1			1 of 10 Decoder	74145N	
IC17	03-30106	1			BCD to 7-Segment decoder/driver	74LS47N	
IC18	03-30113	1			A to D Convertor (analog portion)	Intersil ICL8068ACPD or equiv.	
IC19	03-30114	1			A to D convertor (digital portion)	Intersil ICL71C03ACPI or equiv.	
IC20	03-50014	1			2300 IC20 (Watts range decoder)	Made from 03-30154	
IC21	03-30173	1			Hex inverter open collector (30V)	7406	
J1	05-10294	1			Socket, dil, 20 pin	Burndy DILB20P-108	
J2	05-10294	1			Socket, dil, 20 pin	Burndy DILB20P-108	
J3	05-10294	1			Socket, dil, 20 pin	Burndy DILB20P-108	
J4	05-10294	1			Socket, dil, 20 pin	Burndy DILB20P-108	
J5	05-10310	1			Socket, right angle, 10 way, gold	Molex 22-16-2101	
J6	05-10310	1			Socket, right angle, 10 way, gold	Molex 22-16-2101	
K2	05-03012	1			Relay, Reed, 5V Coil, DIL, Form A	CP Clare: PRMA 1A 05	
K3	05-03012	1			Relay, Reed, 5V Coil, DIL, Form A	CP Clare: PRMA 1A 05	
R1	01-01021	1			100 5% 1/4W Carbon Film	RC07GF101J	
R2	01-01021	1			100 5% 1/4W Carbon Film	RC07GF101J	
R3	01-01073	1			47K 5% 1/4W Carbon Film	RC07GF473J	
R4	01-01061	1			10K 5% 1/4W Carbon Film	RC07GF103J	
R5	01-01081	1			100K 5% 1/4W Carbon Film	RC07GF104J	
R6	01-01070	1			33K 5% 1/4W Carbon Film	RC07GF333J	

REF.DES.	STOCK #	QUANTITY			DESCRIPTION	MANUFACTURING/PURCHASING DATA	ALTERNATE
		A	T	N			
R7	01-01086	1			220K 5% 1/4W Carbon Film	RC07GF224J	
R8	01-10078	1			2K 1% 50ppm/C 1/4W Metal Film	RN60C2001F	
R9	01-50025	1			100 End Adjust	Beckman 89PR100ohm	
R16	01-01030	1			330 5% 1/4W Carbon Film	RC07GF331J	
R17	01-01030	1			330 5% 1/4W Carbon Film	RC07GF331J	
R20	01-01030	1			330 5% 1/4W Carbon Film	RC07GF331J	
R23	01-01061	1			10K 5% 1/4W Carbon Film	RC07GF103J	
R24	01-01021	1			100 5% 1/4W Carbon Film	RC07GF101J	
R25	01-01021	1			100 5% 1/4W Carbon Film	RC07GF101J	
R26	01-01021	1			100 5% 1/4W Carbon Film	RC07GF101J	
R27	01-01061	1			10K 5% 1/4W Carbon Film	RC07GF103J	
R28	01-01073	1			47K 5% 1/4W Carbon Film	RC07GF473J	
R29	01-01061	1			10K 5% 1/4W Carbon Film	RC07GF103J	
R30	01-01081	1			100K 5% 1/4W Carbon Film	RC07GF104J	
R31	01-01070	1			33K 5% 1/4W Carbon Film	RC07GF333J	
R32	01-01086	1			220K 5% 1/4W Carbon Film	RC07GF224J	
R33	01-10078	1			2K 1% 50ppm/C 1/4W Metal Film	RN60C2001F	
R34	01-50025	1			100 End Adjust	Beckman 89PR100ohm	
R35	01-01030	1			330 5% 1/4W Carbon Film	RC07GF331J	
R36	01-01021	1			100 5% 1/4W Carbon Film	RC07GF101J	
R37	01-01021	1			100 5% 1/4W Carbon Film	RC07GF101J	
R38	01-01021	1			100 5% 1/4W Carbon Film	RC07GF101J	
R39	01-01021	1			100 5% 1/4W Carbon Film	RC07GF101J	
R40	01-01053	1			4.7K 5% 1/4W Carbon Film	RC07GF472J	
R41	01-01073	1			47K 5% 1/4W Carbon Film	RC07GF473J	
R42	01-01061	1			10K 5% 1/4W Carbon Film	RC07GF103J	
R43	01-01081	1			100K 5% 1/4W Carbon Film	RC07GF104J	
R44	01-01070	1			33K 5% 1/4W Carbon Film	RC07GF333J	
R45	01-01086	1			220K 5% 1/4W Carbon Film	RC07GF224J	
R46	01-10026	1			374 1% 50ppm/C 1/4W Metal Film	RN60C3740F	
R47	01-10000		1		1 FACTORY SELECT VALUE (1%)	RN60CXX	
R48	01-50025	1			100 End Adjust	Beckman 89PR100ohm	
R49	01-10078	1			2K 1% 50ppm/C 1/4W Metal Film	RN60C2001F	
R51	01-01030	1			330 5% 1/4W Carbon Film	RC07GF331J	
R53	01-01061	1			10K 5% 1/4W Carbon Film	RC07GF103J	
R54	01-01081	1			100K 5% 1/4W Carbon Film	RC07GF104J	
R55	01-01030	1			330 5% 1/4W Carbon Film	RC07GF331J	
RN1	01-40002	1			8 x 100 Network	A-B 316B-101	
RN2	01-40003	1			15 x 10K Network	A-B 316A-103	
RN3	01-40002	1			8 x 100 Network	A-B 316B-101	
RN4	01-40002	1			8 x 100 Network	A-B 316B-101	
S1	05-03052	1			Switch, SPDT, Momentary, Black w/Red LED	Schadow,SEAU0A00105R	
S2	05-03052	1			Switch, SPDT, Momentary, Black w/Red LED	Schadow,SEAU0A00105R	
S3	05-03052	1			Switch, SPDT, Momentary, Black w/Red LED	Schadow,SEAU0A00105R	
S4	05-03052	1			Switch, SPDT, Momentary, Black w/Red LED	Schadow,SEAU0A00105R	
S5	05-03052	1			Switch, SPDT, Momentary, Black w/Red LED	Schadow,SEAU0A00105R	
S6	05-03052	1			Switch, SPDT, Momentary, Black w/Red LED	Schadow,SEAU0A00105R	
S7	05-03052	1			Switch, SPDT, Momentary, Black w/Red LED	Schadow,SEAU0A00105R	
S8	05-03052	1			Switch, SPDT, Momentary, Black w/Red LED	Schadow,SEAU0A00105R	
S9	05-03052	1			Switch, SPDT, Momentary, Black w/Red LED	Schadow,SEAU0A00105R	
S10	05-03052	1			Switch, SPDT, Momentary, Black w/Red LED	Schadow,SEAU0A00105R	

REF.DES.	STOCK #	QUANTITY			DESCRIPTION	MANUFACTURING/PURCHASING DATA	ALTERNATE
		A	T	N			
S11	05-03052	1			Switch, SPDT, Momentary, Black w/Red LED	Schadow,SEAU0A00105R	
S12	05-03052	1			Switch, SPDT, Momentary, Black w/Red LED	Schadow,SEAU0A00105R	
S13	05-03052	1			Switch, SPDT, Momentary, Black w/Red LED	Schadow,SEAU0A00105R	
TR1	03-10013	1			NPN Transistor (TO92)	2N4401	
TR2	03-10013	1			NPN Transistor (TO92)	2N4401	
TR3	03-10013	1			NPN Transistor (TO92)	2N4401	
TR4	03-10013	1			NPN Transistor (TO92)	2N4401	
TR5	03-10013	1			NPN Transistor (TO92)	2N4401	
TR6	03-10013	1			NPN Transistor (TO92)	2N4401	
TR7	03-10013	1			NPN Transistor (TO92)	2N4401	
TR8	03-10013	1			NPN Transistor (TO92)	2N4401	
TR9	03-10013	1			NPN Transistor (TO92)	2N4401	
TR10	03-10013	1			NPN Transistor (TO92)	2N4401	
TR11	03-10013	1			NPN Transistor (TO92)	2N4401	
TR12	03-10013	1			NPN Transistor (TO92)	2N4401	
TR13	03-10010	1			PNP Transistor (TO92)	2N4402	
TR14	03-10013	1			NPN Transistor (TO92)	2N4401	
TR15	03-10013	1			NPN Transistor (TO92)	2N4401	
TR16	03-10013	1			NPN Transistor (TO92)	2N4401	
TR17	03-10013	1			NPN Transistor (TO92)	2N4401	
TR18	03-10013	1			NPN Transistor (TO92)	2N4401	
TR19	03-10013	1			NPN Transistor (TO92)	2N4401	
TR20	03-10013	1			NPN Transistor (TO92)	2N4401	
XIC2	05-10041	1			Socket, dil, 14 pin	Burndy 8514-01	
XIC3	05-10295	1			Socket, dil, 28 pin	Burndy DILB28P-108	
XIC11	05-10041	1			Socket, dil, 14 pin	Burndy 8514-01	
XIC12	05-10295	1			Socket, dil, 28 pin	Burndy DILB28P-108	
XIC13	05-10008	1			Socket, dil, 16 pin	Burndy C8516-01	
XIC18	05-10041	1			Socket, dil, 14 pin	Burndy 8514-01	
XIC19	05-10295	1			Socket, dil, 28 pin	Burndy DILB28P-108	
XIC20	05-10042	1			Socket, dil, 24 pin	TI 8524-01	

REF.DES.	STOCK #	QUANTITY	DESCRIPTION	MANUFACTURING/PURCHASING DATA
	A	T	N	
1	2301-400	1	2301 Final Assy.	Assembly 2300-400
20	04-10647	1	2301L Front Panel (screened)	DWG 2300-101 using 04-10340
IC20	03-50015	1	2300L IC20 (Watts range decoder)	Made from 03-30154
R21	01-10006	1	100K 1% 50ppm/C 1/4W Metal Film	RN60C1003F
R500	01-01021	1	100 5% 1/4W Carbon Film	RC07GF101J

DELETE THE FOLLOWING FROM PARTS LIST: 2300-600 Signal Processing Bd. Assy

R21	01-10007	1	1.0M 1% 50ppm/C 1/2W Metal Film	RN65C1004F
-----	----------	---	---------------------------------	------------

DELETE THE FOLLOWING FROM PARTS LIST: 2300-602 2300 Display Board Assy

DS22	05-01005	1	Single LED, Red, Small	Hewlett Packard, HLMP1000
IC20	03-50014	1	2300 IC20 (Watts Range Decoder)	made from 03-30154

DELETE THE FOLLOWING FROM PARTS LIST: 1000-600 488 IEEE Bd. Assy

IC6	03-50017	1	2300/1 TL-4 ROM	made from 03-30154
-----	----------	---	-----------------	--------------------

WITH OPTION TL-4 INSTALL THE FOLLOWING:

IC6	03-50016	1	2300/1L TL-4 ROM	made from 03-30154
-----	----------	---	------------------	--------------------

WITH OPTION TL-5 INSTALL THE FOLLOWING:

IC6	03-50024	1	2300/1L TL-5 ROM	made from 03-30154
-----	----------	---	------------------	--------------------

DELETE THE FOLLOWING FROM PARTS LIST: 2300-400 2300 Final Assy

20	04-10502	1	2301 Front Panel (screened)	DWG 2301-100 using 04-10396
----	----------	---	-----------------------------	-----------------------------

REF.DES.	STOCK #	QUANTITY			DESCRIPTION	MANUFACTURING/PURCHASING DATA
		A	T	N		
2	80-02126	36			26awg Wire, Brown TFE	M16878/4-BDE-1
3	80-02226	36			26awg Wire, Red TFE	M16878/4-BDE-2
4	80-02326	45			26awg Wire, Orange TFE	M16878/4-BDE-3
5	80-02426	21			26awg Wire, Yellow TFE	M16878/4-BDE-4
6	80-02526	21			26awg Wire, Green TFE	M16878/4-BDE-5
7	80-02726	12			26awg Wire, Violet TFE	M16878/4-BDE-7
8	80-02826	12			26awg Wire, Gray TFE	M16878/4-BDE-8
9	80-02926	12			26awg Wire, White TFE	M16878/4-BDE-9
10	80-02026	12			26awg Wire, Black TFE	M16878/4-BDE-0
11	05-10730	4			Standoff, swage, 1/4 dia., 1/4 lg., 4-40	Useco A1537-B-1/4-16
12	05-10533		1		6 pin, din receptical	Hirschmann DIN45322
13	05-10514		1		6-pin din plug	Switchcraft 12GM6M
14	01-01021	3			100 5% 1/4W Carbon Film	RC07GF101J
15	70-00004	3			1/4" Black Shrink Tubing FP301	3M 3000250BK
16	90-04010		4		#4-40 x 5/8" Phil Pan S.S.	
17	98-04002		4		#4 Internal Star Washer S.S.	
18	05-10261		2		Tie-wrap block, large	Panduit ABM2S-A
19	05-10019		16		Cable tie, 4"x 1/8"	Panduit WRN-4
A1	04-30229	1			IO3-ZW1 Board	DWG 2300-705
C1	02-60017	1			0.1uF,63V,Mylar,5%	WIMA MKC2-0.1uF
C2	02-60017	1			0.1uF,63V,Mylar,5%	WIMA MKC2-0.1uF
IC1	03-30166	1			General Purpose JFET Op-amp	LF411CN
IC2	03-30166	1			General Purpose JFET Op-amp	LF411CN
IC3	03-30166	1			General Purpose JFET Op-amp	LF411CN
R1	01-10001	1			1.0K 1% 50ppm/C 1/4W Metal Film	RN60C1001F
R2	01-10001	1			1.0K 1% 50ppm/C 1/4W Metal Film	RN60C1001F
R3	01-10001	1			1.0K 1% 50ppm/C 1/4W Metal Film	RN60C1001F
R4	01-10001	1			1.0K 1% 50ppm/C 1/4W Metal Film	RN60C1001F
R5	01-10001	1			1.0K 1% 50ppm/C 1/4W Metal Film	RN60C1001F
R6	01-10001	1			1.0K 1% 50ppm/C 1/4W Metal Film	RN60C1001F
RV1	01-50037	1			200 Top Adjust	Beckman 68WR200ohm
RV2	01-50012	1			10K Top Adjust	Beckman 68WR10K
RV3	01-50037	1			200 Top Adjust	Beckman 68WR200ohm
RV4	01-50012	1			10K Top Adjust	Beckman 68WR10K
RV5	01-50037	1			200 Top Adjust	Beckman 68WR200ohm
RV6	01-50012	1			10K Top Adjust	Beckman 68WR10K

REF.DES.	STOCK #	QUANTITY			DESCRIPTION	MANUFACTURING/PURCHASING DATA	ALTERNATE
		A	T	N			
7	05-10244	1			IEEE connector hardware kit	AMP 552633-3	
11	05-10019	2			Cable tie, 4"x 1/8"	Panduit WRN-4	
18	04-10296	2			IEEE/IOX support bracket	DWG 2300-216	
19	90-06006	4			#6-32 x 3/8" Phil Pan S.S.		
20	97-06000	4			#6-32 Standard Hex Nut, S.S.		
21	98-06001	4			#6 Split Lock Washer, STD, S.S.		
22	90-04104	2			#4 x 1/4" Self-Tap Phil Pan Cad		
23	80-01122	36			22AWG Wire, Brown PVC	M16878/1-BFE-1	
24	80-01322	30			22AWG Wire, Orange PVC	M16878/1-BFE-3	
25	80-01422	40			22AWG Wire, Yellow PVC	M16878/1-BFE-4	
26	80-01222	18			22AWG Wire, Red PVC	M16878/1-BFE-2	
27	80-01022	18			22AWG Wire, Black PVC	M16878/1-BFE-0	
28	80-01922	43			22AWG Wire, White PVC	M16878/1-BFE-9	
29	80-01522	18			22AWG Wire, Green PVC	M16878/1-BFE-5	
A1	04-30095	1			2300 "IOX" Analog Output Board	DWG 2300-703	
C1	02-30001	1			10uF 25V Tantalum Bead	AVX TAP106K025SP	
C2	02-30001	1			10uF 25V Tantalum Bead	AVX TAP106K025SP	
IC1	03-30322	1			Dual General Purpose JFET Op Amp	LF353N	
IC2	03-30322	1			Dual General Purpose JFET Op Amp	LF353N	
IC3	03-30322	1			Dual General Purpose JFET Op Amp	LF353N	
IC4	03-30322	1			Dual General Purpose JFET Op Amp	LF353N	
IC5	03-30322	1			Dual General Purpose JFET Op Amp	LF353N	
IC6	03-30322	1			Dual General Purpose JFET Op Amp	LF353N	
J2	05-10243	1			Connector, 24 way, right angle	AMP 552791-1	
R1	01-10065	1			953 1% 50ppm/C 1/4 Metal Film	RN60C9530F	
R2	01-10065	1			953 1% 50ppm/C 1/4 Metal Film	RN60C9530F	
R3	01-10001	1			1.0K 1% 50ppm/C 1/4W Metal Film	RN60C1001F	
R4	01-10014	1			698 1% 50ppm/C 1/4W Metal Film	RN60C6980F	
R5	01-01016	1			56 5% 1/4W Carbon Film	RC07GF560J	
R6	01-01016	1			56 5% 1/4W Carbon Film	RC07GF560J	
R7	01-01016	1			56 5% 1/4W Carbon Film	RC07GF560J	
R8	01-01016	1			56 5% 1/4W Carbon Film	RC07GF560J	
R9	01-01016	1			56 5% 1/4W Carbon Film	RC07GF560J	
R10	01-01016	1			56 5% 1/4W Carbon Film	RC07GF560J	
R11	01-01016	1			56 5% 1/4W Carbon Film	RC07GF560J	
R12	01-01016	1			56 5% 1/4W Carbon Film	RC07GF560J	
R13	01-01016	1			56 5% 1/4W Carbon Film	RC07GF560J	
R14	01-01016	1			56 5% 1/4W Carbon Film	RC07GF560J	
R15	01-01016	1			56 5% 1/4W Carbon Film	RC07GF560J	
RN1	01-40006	1			8 x 100K Network	A-B 316B-104	
RN2	01-40007	1			15 x 100 Network	A-B 316A-101	
RN3	01-40006	1			8 x 100K Network	A-B 316B-104	
RN4	01-40008	1			8 x 1K Network	A-B 316B-102	
RN5	01-40008	1			8 x 1K Network	A-B 316B-102	
RN6	01-40008	1			8 x 1K Network	A-B 316B-102	
RV1	01-50035	1			50K End Adjust	Beckman 89PR50K	
RV2	01-50035	1			50K End Adjust	Beckman 89PR50K	
RV3	01-50035	1			50K End Adjust	Beckman 89PR50K	
RV4	01-50035	1			50K End Adjust	Beckman 89PR50K	
RV5	01-50035	1			50K End Adjust	Beckman 89PR50K	
RV6	01-50035	1			50K End Adjust	Beckman 89PR50K	
RV7	01-50035	1			50K End Adjust	Beckman 89PR50K	



REF.DES.	STOCK #	QUANTITY			DESCRIPTION	MANUFACTURING/PURCHASING DATA	ALTERNATE
		A	T	N			
RV8	01-50035	1			50K End Adjust	Beckman 89PR50K	
RV9	01-50035	1			50K End Adjust	Beckman 89PR50K	
RV10	01-50035	1			50K End Adjust	Beckman 89PR50K	
RV11	01-50035	1			50K End Adjust	Beckman 89PR50K	
RV12	01-50043	1			200 End Adjust	Beckman 89PR200ohm	
RV13	01-50043	1			200 End Adjust	Beckman 89PR200ohm	
RV14	01-50025	1			100 End Adjust	Beckman 89PR100ohm	
RV15	01-50025	1			100 End Adjust	Beckman 89PR100ohm	
RV16	01-50025	1			100 End Adjust	Beckman 89PR100ohm	
RV17	01-50043	1			200 End Adjust	Beckman 89PR200ohm	
RV18	01-50043	1			200 End Adjust	Beckman 89PR200ohm	
RV19	01-50025	1			100 End Adjust	Beckman 89PR100ohm	
RV20	01-50025	1			100 End Adjust	Beckman 89PR100ohm	
RV21	01-50043	1			200 End Adjust	Beckman 89PR200ohm	
RV22	01-50043	1			200 End Adjust	Beckman 89PR200ohm	
RV23	01-50025	1			100 End Adjust	Beckman 89PR100ohm	
RV24	01-50025	1			100 End Adjust	Beckman 89PR100ohm	
RV25	01-50025	1			100 End Adjust	Beckman 89PR100ohm	

REF.DES.	STOCK #	QUANTITY	DESCRIPTION	MANUFACTURING/PURCHASING DATA	ALTERNATE
		A T N			
5	05-10086	1	Solder lug, #6, internal star	Smith 1412-6	
6	70-00003	1	3/16" Black Shrink Tubing	3000187 BLK 3M	
7	05-10086	1	Solder lug, #6, internal star	Smith 1412-6	
11	80-01222	6	22AWG Wire, Red PVC	M16878/1-BFE-2	
16	80-01022	6	22AWG Wire, Black PVC	M16878/1-BFE-0	
18	05-10244	1	IEEE connector hardware kit	AMP 552633-3	
19	80-02520	3	20awg Wire, Green TFE	M16878/4-BGE-5	
28	04-30084	1	IEEE 488 Board	DWG 1000-700	
29	04-10296	2	IEEE/IOX support bracket	DWG 2300-216	
31	90-06006	4	#6-32 x 3/8" Phil Pan S.S.		
32	98-06001	3	#6 Split Lock Washer, STD, S.S.		
33	97-06001	4	#6-32 Hex Nut, Small Pattern, Stainless-Steel		
40	90-04504	2	4-40 x 1/4, Self-Tap, Phil, Pan hd, S.S., Type AB		
C1	02-30014	1	100u 10V Tantalum Bead	AVX TAP106K025SP	
C2	02-20018	1	33p 500V Mica	CM05FD330J03	
C3	02-20018	1	33p 500V Mica	CM05FD330J03	
C4	02-10006	1	0.01uF 50V Ceramic disc	Illinois 103GR050-Z	
C5	02-10006	1	0.01uF 50V Ceramic disc	Illinois 103GR050-Z	
C6	02-10006	1	0.01uF 50V Ceramic disc	Illinois 103GR050-Z	
C7	02-10006	1	0.01uF 50V Ceramic disc	Illinois 103GR050-Z	
C8	02-30002	1	33uF 10V Tantalum Bead	IDC336K010NLF	
C9	02-30002	1	33uF 10V Tantalum Bead	IDC336K010NLF	
D1	03-20000	1	Diode, general purpose	1N4148 or 1N914	
IC1	03-30156	1	Octal 3-State Buffer	74ALS541N or 74LS541N	03-30401
IC2	03-30157	1	Octal GPIB Transceiver (Thin Package)	Motorola MC3447P3	
IC3	03-30157	1	Octal GPIB Transceiver (Thin Package)	Motorola MC3447P3	
IC4	03-30158	1	GPIB to MPU Interface	MC68488P	
IC5	03-30160	1	Microprocessor with RAM (1MHz)	MC6802P	
IC7	03-30155	1	Binary to 1 of 8 decoder	74ALS138N or 74LS138N	
IC8	03-30159	1	Peripheral Interface Adapter (1.5MHz)	MC68A21P	
IC9	03-30159	1	Peripheral Interface Adapter (1.5MHz)	MC68A21P	
IC10	03-30159	1	Peripheral Interface Adapter (1.5MHz)	MC68A21P	
IC11	03-30159	1	Peripheral Interface Adapter (1.5MHz)	MC68A21P	
IC12	03-30184	1	Hex invertor	74ALS04N or 74LS04N	
IC13	03-30034	1	Regulator, +5V, 0.5A, TO202 or TO220	78M05CP or LM340T-5.0	
R1	01-01061	1	10K 5% 1/4W Carbon Film	RC07GF103J	
R2	01-01061	1	10K 5% 1/4W Carbon Film	RC07GF103J	
R3	01-01061	1	10K 5% 1/4W Carbon Film	RC07GF103J	
R4	01-01061	1	10K 5% 1/4W Carbon Film	RC07GF103J	
R5	01-01061	1	10K 5% 1/4W Carbon Film	RC07GF103J	
R6	01-01061	1	10K 5% 1/4W Carbon Film	RC07GF103J	
R7	01-01061	1	10K 5% 1/4W Carbon Film	RC07GF103J	
R8	01-01061	1	10K 5% 1/4W Carbon Film	RC07GF103J	
R9	01-01061	1	10K 5% 1/4W Carbon Film	RC07GF103J	
R10	01-01061	1	10K 5% 1/4W Carbon Film	RC07GF103J	
R11	01-01061	1	10K 5% 1/4W Carbon Film	RC07GF103J	
S1	05-03091	1	Switch, Dip, Rt. Angle, 5 Position	Grayhill, 76PSB05	
SK1	05-10345	1	Cable 20pin Dil to 20pin Dil, 16.00 inches	DWG 2703-053	
SK2	05-10345	1	Cable 20pin Dil to 20pin Dil, 16.00 inches	DWG 2703-053	
SK3	05-10345	1	Cable 20pin Dil to 20pin Dil, 16.00 inches	DWG 2703-053	
SK4	05-10345	1	Cable 20pin Dil to 20pin Dil, 16.00 inches	DWG 2703-053	

REF.DES.	STOCK #	QUANTITY			DESCRIPTION	MANUFACTURING/PURCHASING DATA	ALTERNATE
		A	T	N			
SK5	05-10243	1			Connector, 24 way, right angle	AMP 552791-1	
TR1	03-10013	1			NPN Transistor (TO92)	2N4401	
TR2	03-10013	1			NPN Transistor (TO92)	2N4401	
TR3	03-10013	1			NPN Transistor (TO92)	2N4401	
TR4	03-10013	1			NPN Transistor (TO92)	2N4401	
XIC4	05-10246	1			Socket, dil, 40 pin	Burndy DILB40P-11	
XIC5	05-10246	1			Socket, dil, 40 pin	Burndy DILB40P-11	
XIC6	05-10042	1			Socket, dil, 24 pin	TI 8524-01	
XIC8	05-10246	1			Socket, dil, 40 pin	Burndy DILB40P-11	
XIC9	05-10246	1			Socket, dil, 40 pin	Burndy DILB40P-11	
XIC10	05-10246	1			Socket, dil, 40 pin	Burndy DILB40P-11	
XIC11	05-10246	1			Socket, dil, 40 pin	Burndy DILB40P-11	
XSK1	05-10294	1			Socket, dil, 20 pin	Burndy DILB20P-108	
XSK2	05-10294	1			Socket, dil, 20 pin	Burndy DILB20P-108	
XSK3	05-10294	1			Socket, dil, 20 pin	Burndy DILB20P-108	
XSK4	05-10294	1			Socket, dil, 20 pin	Burndy DILB20P-108	
Y1	05-02004	1			Crystal,MPU,4MHz	HC18-4MHz	

REF.DES.	STOCK #	QUANTITY	DESCRIPTION	MANUFACTURING/PURCHASING DATA
	A	T	N	

DELETE THE FOLLOWING FROM PARTS LIST : 2300-601 Main PCB Assembly

C105	02-60000	1	0.0047uF 100V Mylar
C106	02-60000	1	0.0047uF 100V Mylar
C107	02-60000	1	0.0047uF 100V Mylar
C108	02-60000	1	0.0047uF 100V Mylar
C109	02-60000	1	0.0047uF 100V Mylar
C110	02-60000	1	0.0047uF 100V Mylar
C205	02-60000	1	0.0047uF 100V Mylar
C206	02-60000	1	0.0047uF 100V Mylar
C207	02-60000	1	0.0047uF 100V Mylar
C208	02-60000	1	0.0047uF 100V Mylar
C209	02-60000	1	0.0047uF 100V Mylar
C210	02-60000	1	0.0047uF 100V Mylar
C305	02-60000	1	0.0047uF 100V Mylar
C306	02-60000	1	0.0047uF 100V Mylar
C307	02-60000	1	0.0047uF 100V Mylar
C308	02-60000	1	0.0047uF 100V Mylar
C309	02-60000	1	0.0047uF 100V Mylar
C310	02-60000	1	0.0047uF 100V Mylar

ADD THE FOLLOWING TO PARTS LIST : 2300-601 Main PCB Assembly

C105	02-90002	1	0.5u 5% 50V Polycarbonate	IMB RA7A504J
C106	02-90002	1	0.5u 5% 50V Polycarbonate	IMB RA7A504J
C107	02-90002	1	0.5u 5% 50V Polycarbonate	IMB RA7A504J
C108	02-90002	1	0.5u 5% 50V Polycarbonate	IMB RA7A504J
C109	02-90002	1	0.5u 5% 50V Polycarbonate	IMB RA7A504J
C110	02-90002	1	0.5u 5% 50V Polycarbonate	IMB RA7A504J
C205	02-90002	1	0.5u 5% 50V Polycarbonate	IMB RA7A504J
C206	02-90002	1	0.5u 5% 50V Polycarbonate	IMB RA7A504J
C207	02-90002	1	0.5u 5% 50V Polycarbonate	IMB RA7A504J
C208	02-90002	1	0.5u 5% 50V Polycarbonate	IMB RA7A504J
C209	02-90002	1	0.5u 5% 50V Polycarbonate	IMB RA7A504J
C210	02-90002	1	0.5u 5% 50V Polycarbonate	IMB RA7A504J
C305	02-90002	1	0.5u 5% 50V Polycarbonate	IMB RA7A504J
C306	02-90002	1	0.5u 5% 50V Polycarbonate	IMB RA7A504J
C307	02-90002	1	0.5u 5% 50V Polycarbonate	IMB RA7A504J
C308	02-90002	1	0.5u 5% 50V Polycarbonate	IMB RA7A504J
C309	02-90002	1	0.5u 5% 50V Polycarbonate	IMB RA7A504J
C310	02-90002	1	0.5u 5% 50V Polycarbonate	IMB RA7A504J

DELETE THE FOLLOWING FROM PARTS LIST : 2300-600 2300 Signal Processing Bd. Assy.

C18	02-90005	1	0.1u 5% 50V Polycarbonate	IMB RA7A104J
-----	----------	---	---------------------------	--------------

ADD THE FOLLOWING TO PARTS LIST : 2300-600 2300 Signal Processing Bd. Assy.

C18	02-90006	1	1u 5% 50V Polycarbonate	IMB RA20105J
-----	----------	---	-------------------------	--------------

REF.DES.	STOCK #	QUANTITY	DESCRIPTION	MANUFACTURING/PURCHASING DATA
		A T N		

DELETE THE FOLLOWING FROM PARTS LIST : 2300-602 Display PCB Assembly

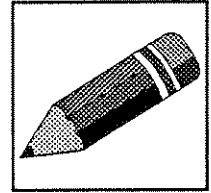
C2	02-50000	1	0.22u 10% 50V Polystyrene	F-Dyne FSA 0.22uF or Equiv.
C12	02-50000	1	0.22u 10% 50V Polystyrene	F-Dyne FSA 0.22uF or Equiv.
C18	02-50000	1	0.22u 10% 50V Polystyrene	F-Dyne FSA 0.22uF or Equiv.

ADD THE FOLLOWING TO PARTS LIST : 2300-602 Display PCB Assembly

C2	02-90002	1	0.5u 5% 50V Polycarbonate	IMB RA7A504J
C12	02-90002	1	0.5u 5% 50V Polycarbonate	IMB RA7A504J
C18	02-90002	1	0.5u 5% 50V Polycarbonate	IMB RA7A504J

## SECTION XIV DRAWINGS AND SCHEMATICS

---



The following drawings have been included in this manual:

2300/01 Chassis Assembly .....	2300-400
2300/01 Signal Processing Board Schematic .....	2300-070
2300/01 Signal Processing Board Assembly .....	2300-600
2300 Main PCB Schematic .....	2300-071
2300 Main PCB Assembly .....	2300-601
2300 Display PCB Schematic .....	2300-072
2300 Display PCB Assembly .....	2300-602
Option IOX Assembly .....	2300-603
Option IOX Schematic .....	2300-073
2301 Main PCB Schematic .....	2301-071
2301 Main PCB Assembly .....	2301-601
2301 Display PCB Schematic .....	2301-072
2301 Display PCB Assembly .....	2301-602
Option IO-3 Assembly .....	2300-605
Option IO-3 Schematic .....	2300-075
Option TL-4 IEEE-488 Board Schematic .....	1000-070
Option TL-4 IEEE-488 Board Assembly .....	1000-600
Option TL-4 IEEE-488 Board Installation .....	2300-402