

TOPWARD

3000 Series Operation Manual

3000 Series

Copyright

Copyright © 1995 by this company. All rights reserved. No part of this publication may be reproduced in any form or by any means without the written permission of this company.

Disclaimer

This company makes no representations or warranties, either expressed or implied, with respect to the contents hereof and specifically disclaims any warranties, merchantability or fitness for any particular purpose. Further, this company reserves the right to revise this publication and to make changes from time to time in the contents hereof without obligation of this company to notify any person of such revision or changes.

3000 Series

Table of Contents

1. Overview	1
1.1 Introduction.....	1
1.2 Unpacking and Checking	1
2. Front, Rear and Bottom Panels.....	2
2.1 Front Panels	2
2.2 Rear Panels and Bottom Panels	5
3. Operation	7
3.1 Pre-installation.....	7
3.2 Setting the Output Voltage and Output Current	7
3.3 Constant Voltage/Constant Current Characteristics	8
3.4 Operation Modes.....	8
3.4.1 Serial.....	8
3.4.2 Parallel.....	9
4. Maintenance.....	11
4.1 Changing the Fuse.....	11
4.2 Changing the Voltage.....	11
5. Specifications	12

1. Overview

This 3000 Series Direct Current (DC) Power Supply Operation Manual contains an introduction to the power supply, a description of its functions, the operation procedure, the scope of application and the specifications. The models are the 3203A, 3203AR, 3203D, 3203DR, 3302A, 3302AR, 3302D, 3302DR, 3303A, 3303AR, 3303D, 3303DR, 3601A, 3601AR, 3601D, 3601DR, 3306D, 3306DR, 3603D, 3603DR, 33010D and 33010DR.

1.1 Introduction

The 3000 Series is a single-channel-output DC power supply with the following features:

- Constant voltage and constant current output
- Short circuit and external input protection
- Allows serial or parallel connection with the same power supply model

Special Functions on Remote Models

The following functions are available only on the remote models 3203AR, 3203DR, 3302AR, 3302DR, 3303AR, 3303DR, 3601AR, 3601DR, 3306DR, 3603DR and 33010DR:

- Output voltage readback
- Output current readback
- Remote or manual-controlled ON/OFF without using the power switch
- Control of output voltage and current using external voltage and resistor
- Remote sensing

1.2 Unpacking and Checking

Unpack and check that you have the following items:

- One power cable
- This Operation Manual
- Remote-Control Operation Manual (remote models only)
- One ACS-002 banana clip
- Two phone jacks (remote models only)
- Two 9-pin RS-232C connectors (remote models only)

3000 Series

2. Front, Rear and Bottom Panels

2.1 Front Panels

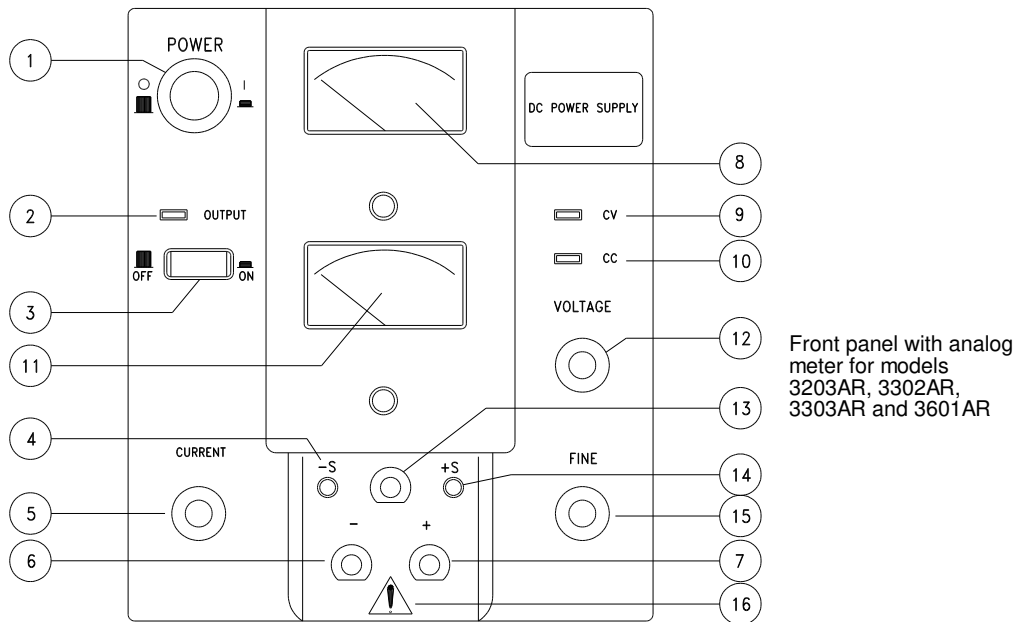
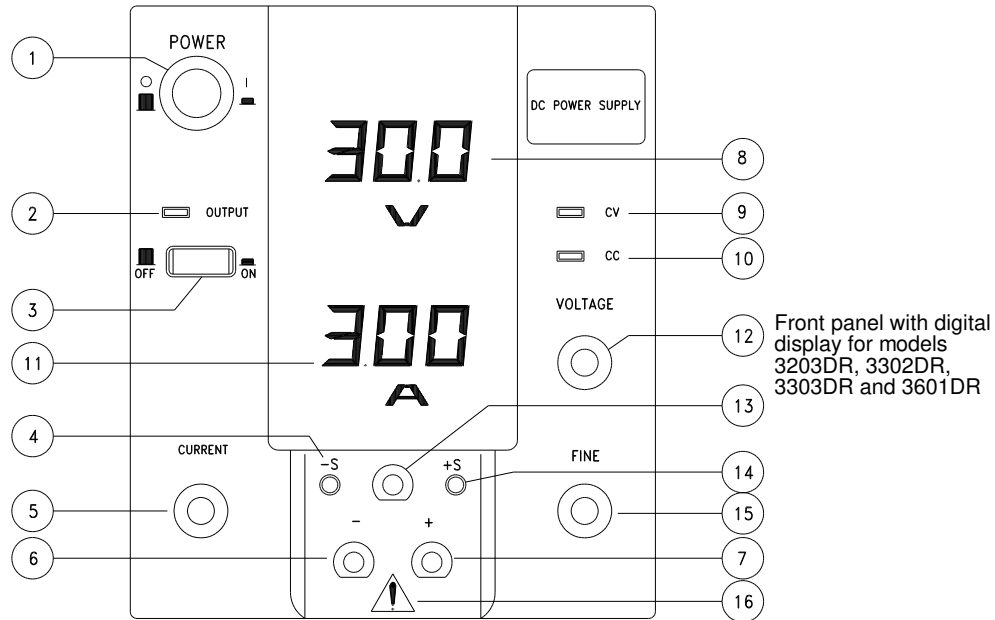

3000 Series

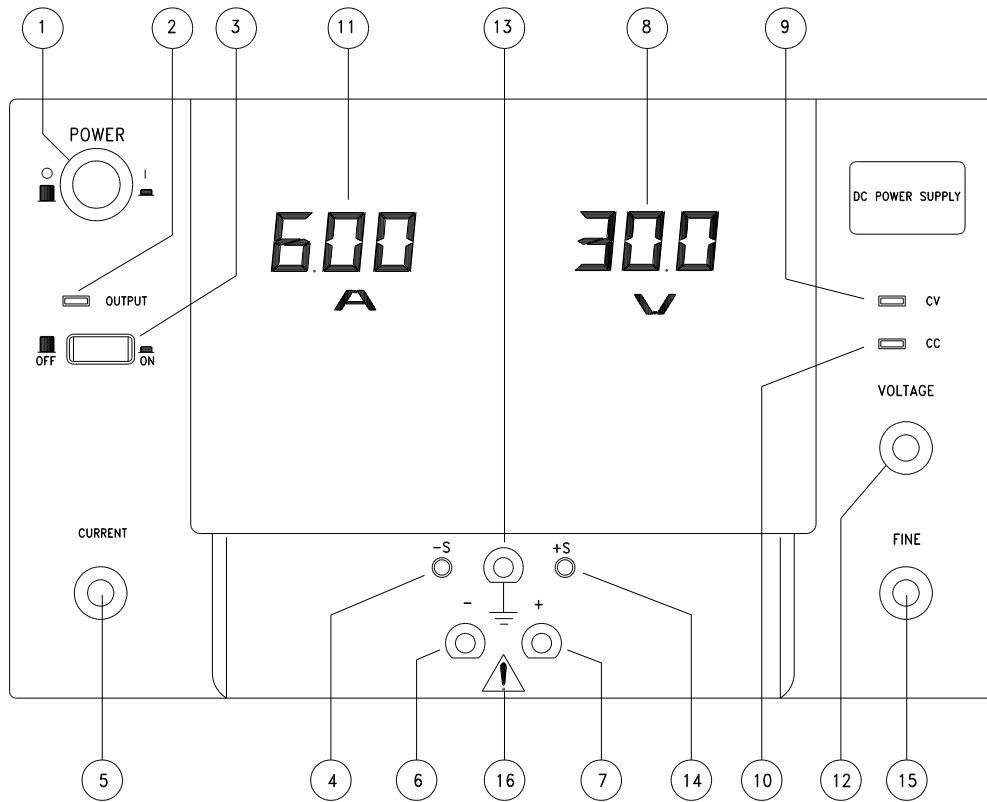

Front panel with digital display for models 3306DR, 3603DR and 33010DR

Figure 1 Front Panels

3000 Series

- (1) Power Switch: Power ON/OFF switch (1=ON, 0 = OFF)
- (2) Output ON/OFF LED: Red LED for indicating output ON or OFF
- (3) Output ON/OFF Switch: Output ON/OFF control switch (only available in remote models)
- (4) -S Remote Sensing Input Terminal: For sensing output voltage at the - load terminal (only available in remote models)
- (5) Output Current Adjustment Knob: For adjusting output current at constant current (C.C. Mode)
- (6) - Output Terminal: Negative output terminal (black)
- (7) + Output Terminal: Positive output terminal (red)
- (8) Voltage Indicator
 - a) Analog: As indicated by the pointer on the 40x40mm (Class 2.5) meter
 - b) Digital: Displayed in full 3-digit red 0.52" LED
- (9) C.V. Mode LED: Green LED to indicate constant voltage
- (10) C.C. Mode LED: Red LED to indicate constant current
- (11) Current Indicator
 - a) Analog: As indicated by the pointer on the 40x40mm (Class 2.5) meter
 - b) Digital: Displayed in full 3-digit red 0.52" LED
- (12) Coarse Output Voltage Adjustment Knob: For adjusting output voltage at constant voltage (C.V. mode)
- (13) GND Terminal : Ground terminal (green)
- (14) +S Remote Sensing Input Terminal: For sensing output voltage at the + load terminal (only available in remote models)
- (15) Fine Output Voltage Adjustment Knob: For fine adjustment of output voltage at constant voltage (C.V. mode)
- (16) Warning Label: The bare parts of the output terminals and fittings are electrical sensing parts. Do not touch these parts during use.

3000 Series

2.2 Rear Panels and Bottom Panels

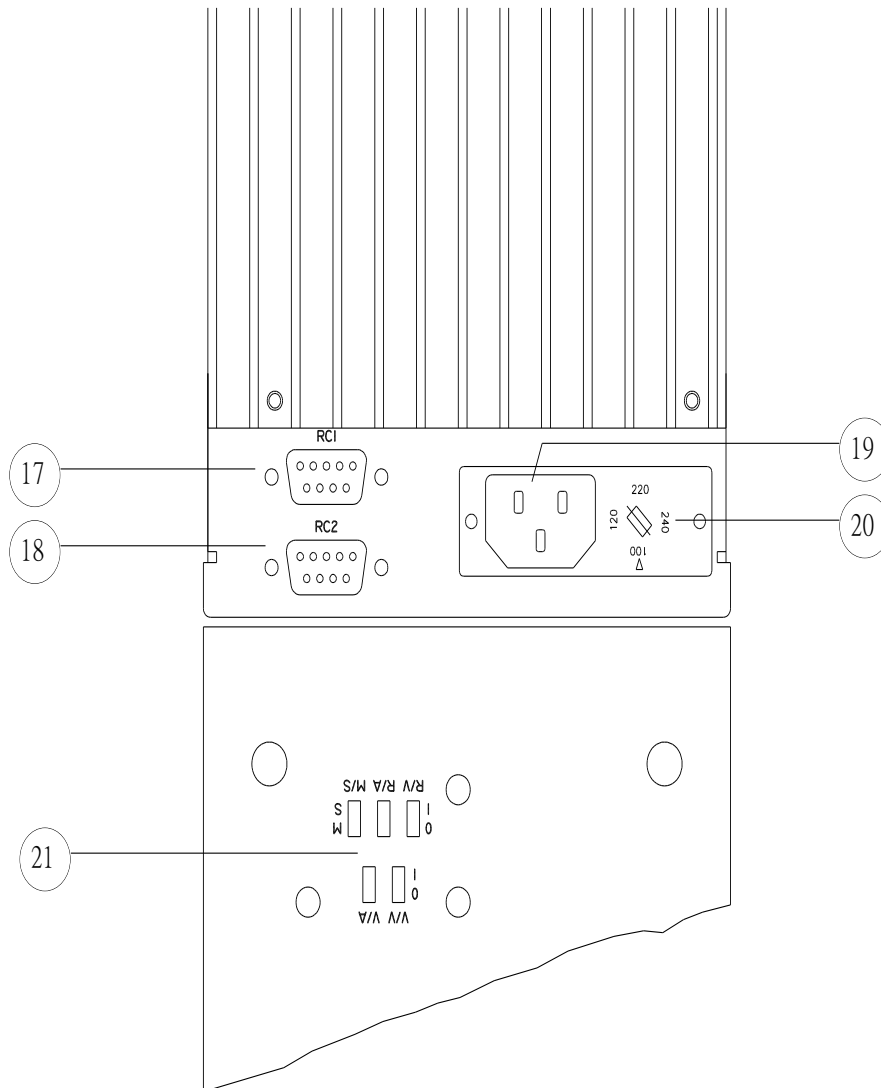

Rear and bottom panels for models 3203AR, 3203DR, 3302AR, 3203DR, 3303AR, 3303DR, 3601AR and 3601DR

3000 Series

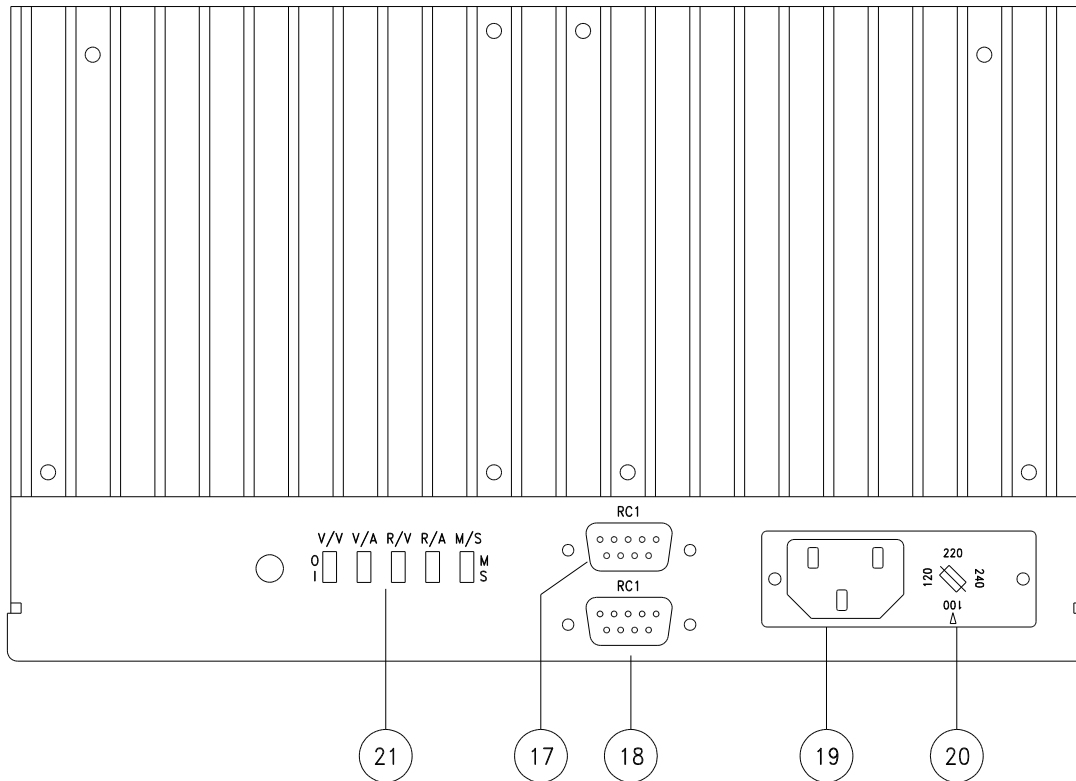

Rear and bottom panels for models 3306DR, 3603DR and 33010DR

Figure 2 Rear and Bottom Panels

- (17) D-Type 9-pin connector (RC1) for Remote Control
- (18) D-Type 9-pin connector (RC2) for Remote Control

NOTE: Items 17 and 18 are available only on the remote models. Refer to the Remote-Control Operation Manual for details.

- (19) Power Input Socket
- (20) Input Power Fuse Holder and Input Voltage Selector. Acceptable input voltage ratings are 100V, 120V, 220V and 240V. The selected input voltage is set to the position above the \triangle mark (the rear panel above shows that the input voltage is set to 100V).
- (21) Remote Control Function Switches: Only available on remote models. Refer to the Remote-Control Operation Manual for details.

3. Operation

3.1 Pre-installation

Before you turn on the power:

- Check that the input voltage from your power source conforms to the voltage rating selected. Refer to Input Voltage Selector in section 2.2. The tolerance is $\pm 10\%$ of the indicated voltage at 50/60 Hz.
- Place this power supply in a well-ventilated area and do not block the ventilation holes. Poor heat dissipation leads to overheating which may cause unstable operation and shorten the service life of this equipment.
- Be sure to use the correct fuse for your model. Refer to Table 1 for the type of fuse you should use for a given voltage.

3.2 Setting the Output Voltage and Output Current

To set the output voltage and current, follow these steps:

1. Check that the total load to be connected does not exceed the maximum output voltage and current of this power supply.
2. Open the circuit between the + and the - output terminals. Turn the voltage adjustment knob clockwise to the desired output voltage rating.
3. Turn the current adjustment knob counterclockwise to get the minimum value.
4. Short the circuit between the + and the - output terminals. Note that the current rating of the shorting wire should be greater than or equal to the required current.
5. Turn the current adjustment knob clockwise until the current indicator on the front panel displays the required current rating.
6. Remove the shorting wire from the + and the - output terminals. The power supply returns to the constant voltage mode and is ready to use.

3000 Series

3.3 Constant Voltage/Constant Current Characteristics

This power supply operates automatically between constant voltage (C. V. mode) and constant current (C. C. mode) by responding quickly to rapid load changes. The following figures shows the relative changes between the constant current and the constant voltage modes.

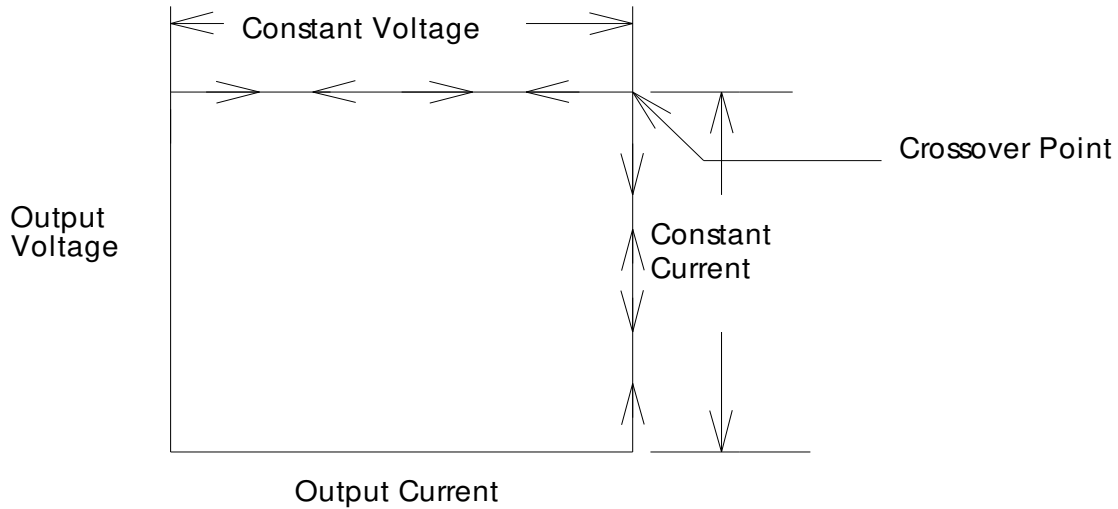

Figure 3 Constant Voltage vs. Constant Current Relation Diagram

3.4 Operation Modes

3.4.1 Serial

Serial connection allows the connection of two or more power supplies serially to obtain a higher voltage rating (maximum 240V for this power supply).

For serial connection, it is recommended that all power supplies operate under the constant voltage (C.V.) mode.

Figure 4 shows the serial connection between two 3303D power supplies. One unit is set at 30V/2A and the other at 20V/3A. Figure 5 shows the serial connection voltage/current output versus load changes.

3000 Series

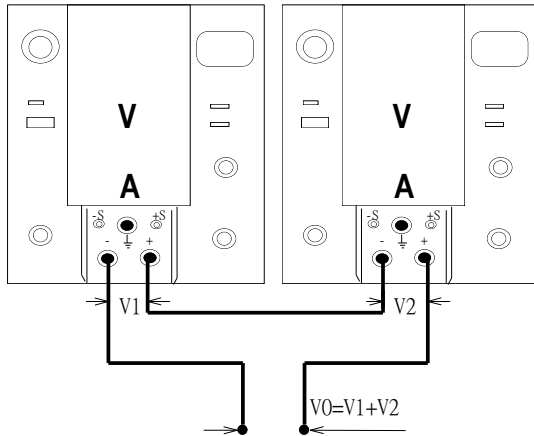

Figure 4 Serial Connection Diagram

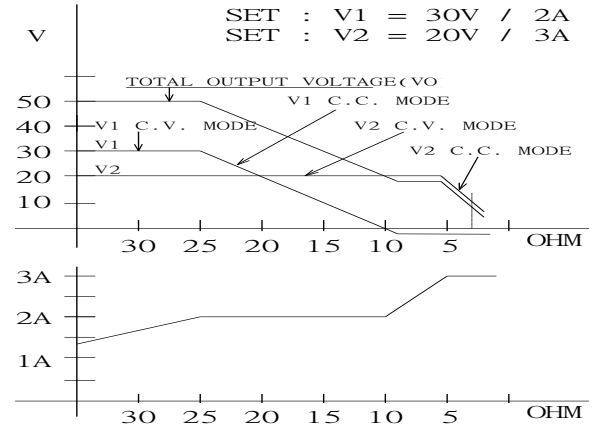

Figure 5 Serial Voltage/Current Output vs. Load Change

3.4.2 Parallel

Parallel connection only allows the connection of two or more power supplies of the same model to obtain a higher current rating (maximum 24A for this power supply).

Figure 6 shows the parallel connection of two 3303D power supplies. One unit is set at 30V/3A and the other at 20V/2.5A. Figure 7 shows the parallel connection voltage/current output versus load changes.

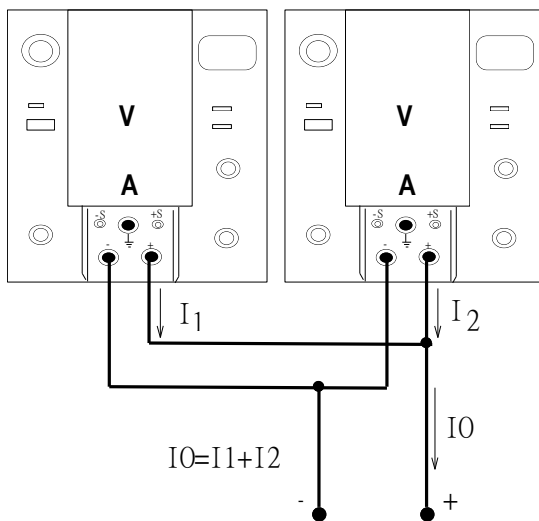

Figure 6 Parallel Connection Diagram

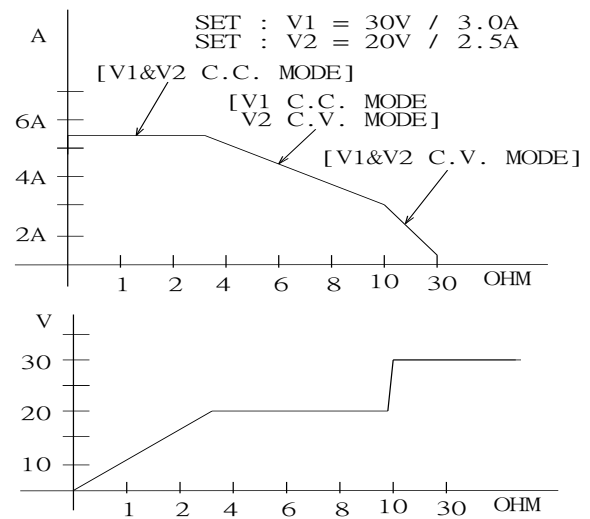

Figure 7 Parallel Voltage/Current Output vs. Load Change

3000 Series

NOTE: The difference between the voltage settings for two or more power supplies of the same model connected in parallel should not exceed 15V. The minimum voltage setting should not be lower than 10V. If it is necessary to be lower than 10V, the voltage difference should be less than 2V. The closer to 0V the smaller the difference required.

4. Maintenance

4.1 Changing the Fuse

The fuse is located inside the input power fuse holder (refer to Figure 2). You need to change the fuse when:

- the fuse is blown out
- you change the voltage rating

In any case, replace the fuse with one of the same rating. Refer to Table 1 for the type of fuse used for each model and voltage.

NOTE: Unplug the power cord before you change the fuse.

4.2 Changing the Voltage

To change the voltage, follow these steps:

1. Use a flathead screwdriver to detach the Input Power Fuse Holder and Input Voltage Selector unit (refer to Figure 2).
2. Turn the unit so that the desired input voltage is positioned above the \triangle mark.
4. Check that the fuse to conform to this new voltage rating. Refer to Table 1 below for the correct fuse rating.
5. Replace the Input Power Fuse Holder and Input Voltage Selector unit.

Table 1 Power Supply Weight , Dimensions and Fuse Specification

Model	Weight (Approx.)		Dimension W x H x D (mm)		Fuse Time-Delay Type 6 x 30 mm			
	Net	Gross	Machine	Package	100V	120V	220V	240V
3203A/AR/D/DR	4.3 KG	5.5 KG	120x160x200	239x265x394	2A	2A	1A	1A
3302A/AR/D/DR	4.3 KG	5.5 KG	120x160x200	239x265x394	2A	2A	1A	1A
3303A/AR/D/DR	4.3 KG	5.5 KG	120x160x200	239x265x394	2A	2A	1A	1A
3601A/AR/D/DR	4.3 KG	5.5 KG	120x160x200	239x265x394	2A	2A	1A	1A
3306D/DR	8.6 KG	10.1 KG	230x160x324	364x265x422	4A	4A	2A	2A
3603D/DR	8.6 KG	10.1 KG	230x160x324	364x265x422	4A	4A	2A	2A
33010D/DR	13 KG	14.4 KG	230x160x366	364x265x464	8A	8A	4A	4A

3000 Series

5. Specifications

Model	3203A 3203D	3302A 3302D	3303A 3303D	3601A 3601D	3306D	3603D	33010D
Specification							
Output Voltage	0-20V	0-30V	0-30V	0-60V	0-30V	0-60V	0-30V
Output Current	0-3A	0-2A	0-3A	0-1A	0-6A	0-3A	0-10A
CONSTANT VOLTAGE CHARACTERISTICS							
Load Regulation	± 0.01% +2mV						
Line Regulation	± 0.01% +2mV						
Ripple & Noise (≤100W)	≤0.5mVrms						
Ripple & Noise (≥100W)	≤1mVrms						
CONSTANT CURRENT CHARACTERISTICS							
Load Regulation (≤100W)	≤10mA						
Load Regulation (≥100W)	≤15mA						
Line Regulation	± 0.01% +2mA						
Ripple & Noise (≤100W)	≤1mA _{rms}						
Ripple & Noise (≥100W)	≤3mA _{rms}						
DISPLAY ACCURACY							
Analog Display (A)	Full-scale 3%						
Digital Display (D)	≤0.1% +2d						
PROGRAMMING SPEED							
Rise Time (No Load)	≤100mS						
(Load)	≤200mS (<6A), ≤ 500mS (<10A), ≤ 1S (≥10A)						
Fall Time (No Load)	≤2.5S						
(Load)	≤250mS						
OUTPUT IMPEDANCE	< 2mΩ + 2 μ H						
RECOVERY TIME	≤100 μ S to within 0.1% of set voltage (50% to 100% load change)						
FUNCTIONS							
Series Connection	Different models can be connected in series (≤240V)						
Parallel Connection	Same models can be connected in parallel (≤ 24 A)						
Master - Slave	N/A						
POWER SOURCE	ACV 100/120/220/240 ±10%, 50/60Hz						
ACCESSORIES	ACS-002 X1						
DIMENSIONS	120 X 160 X 200				230 X 160 X 324		230 X 160
W X H X D (mm)							X 366

3000 Series

Model	3203AR	3302AR	3303AR	3601AR	3306DR	603DR	33010DR
Specification	3203DR	3302DR	3303DR	3601DR			
Output Voltage	0-20V	0-30V	0-30V	0-60V	0-30V	0-60V	0-30V
Output Current	0-3A	0-2A	0-3A	0-1A	0-6A	0-3A	0-10A
CONSTANT VOLTAGE CHARACTERISTICS							
Load Regulation	± 0.01% +2mV						
Line Regulation	± 0.01% +2mV						
Ripple & Noise (≤100W)	≤ 1mVrms						
Ripple & Noise (≥ 100W)	≤ 2mVrms						
CONSTANT CURRENT CHARACTERISTICS							
Load Regulation (≤ 100W)	≤ 10mA						
Load Regulation (≥ 100W)	≤ 15mA						
Line Regulation	± 0.01% +2mA						
Ripple & Noise (≤100W)	≤ 1mArms						
Ripple & Noise (≥ 100W)	≤ 3mArms						
DISPLAY ACCURACY							
Analog Display (A)	Full-scale 3%						
Digital Display (D)	≤ 0.1% +2d						
PROGRAMMING SPEED							
Rise Time (No Load)	≤ 100mS						
(Load)	≤ 200mS (<6A), ≤ 500mS (<10A), ≤ 1S (≥ 10A)						
Fall Time (No Load)	≤ 2.5S						
(Load)	≤ 250mS						
OUTPUT IMPEDANCE	<2mΩ + 2μ H						
RECOVERY TIME	≤ 100μ S to within 0.1% of set voltage (50% to 100% load change)						
FUNCTIONS							
Serial Connection	Different models can be connected in series (≤ 240V)						
Parallel Connection	Same models can be connected in parallel (≤ 24A)						
Master - Slave	Yes						
REMOTE CONTROL							
Voltage Programmable							
By External DC Voltage	0 to 10V, Control 0 to voltage setting						
By External Resistance	0 to 10KΩ, Control 0 to maximum voltage						
Current Programmable							
By External DC Voltage	0 to 10V, Control 0 to current setting						
By External Resistance	0 to 10KΩ, Control 0 to maximum current						
VOLTAGE/CURRENT READBACK AVAILABLE							
Voltage Readback	0 to 10V for full-scale voltage						
Current Readback	0 to 0.3V for full-scale current						
OUTPUT ON/OFF CONTROL	YES						
REMOTE SENSING	Compensate voltage drop Up to 2VDC						
POWER SOURCE	ACV 100/120/220/240 ±10%, 50/60Hz						
ACCESSORIES	ACS-002 X1, phone-jack plug X2, 9-pin D-type connector X 2						
DIMENSIONS	120 X 160 X 200				230 X 160 X 324		230 X 160
W X H X D (mm)							X 366