

Ethertest

Ethernet LAN Analyzer

Key Features and Benefits

- Ideal for field engineers, software/hardware developers, communications specialists, and network supervisors
- Supports 10 mbps and 100 mbps Ethernet
- Provides a wide array of statistics
- Captures to RAM or directly to disk with no file size limit
- Filters can be broad or set to specific packet fields to let you see the data you want to see, how you want to see it
- Frames timestamped to a resolution of one microsecond
- Imports other sniffer formats to take advantage of Ethertest's superior decode, display and filter capabilities

This feature-rich protocol analyzer offers a suite of protocol decodes and a comprehensive array of network statistic which are in demand today by communications and network professionals. In applications ranging from finance to manufacturing, high-speed Ethernet networks have displaced slower-speed serial data communications networks as the solution of choice to interconnect instrumentation and equipment such as meters, gauges, sensors, transaction terminals, factory equipment and other networked devices.

Ethertest is a passive and easy-to-use network monitor that helps less skilled troubleshooters understand what is happening on their communications networks. The Network View, Statistics Display, and Frame Display are intuitive, easy to read, and quickly provide a wealth of information about the network. Although Ethertest is simple to work with, it does provide a level of sophisticated and detailed information demanded by today's network specialist.

Node Statistics

Ethertest's Network View enables you to see communications traffic details and node information for active nodes on the monitored side of the switch, including:

- packets and bytes transmitted and received
- DNS names
- IP address and MAC information/named MAC address
- NetBIOS names, and assigned user-friendly names for each node

Protocol Decoding

The detailed information in the Frame Display window is presented clearly and with as much, or as little, detail as you need. The Frame Display features:

- summary information for messages sent and received
- message frames decoded into text
- protocol errors clearly identified
- messages shown in Binary, Octal, Hex and ASCII
- side-by-side comparisons with multiple display windows

Network Statistics

Three selectable views-- session, resettable and buffer-- prove quick and easy network statistical displays such as:

- network utilization (current, average and peak)
- frames and bytes per second
- communications data breakdown
- frame sizes
- types and numbers of errors

Specifications

Hardware Minimum Requirements

- Windows XP
- 512 MB RAM
- 1 GHz Pentium PC or equivalent
- 50 MB hard disk space
- PC-Compatible NIC

Protocol Decodes

- TCP/IP (including ARP, RARP, DNS, HTTP, ICMP, IGMP, NBDS, NBNS, NBSS, SMTP, UDP)
- IBM NetBIOS (Windows networking)
- SMB
- Novell Netware (including IPX, SPX, IPX NetBIOS, IPX RIP, IPX SAP, NCP)
- ISO CLNP
- custom, using FrameDecoder® option

File Formats

- Import sniffer Type 1 (.enc)
- Shomiti
- Snoop (Sun Snoop)

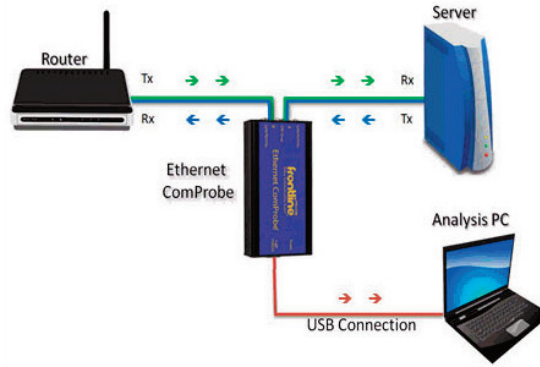

Typical setup of Ethernet ComProbe for use with PC running Ethertest

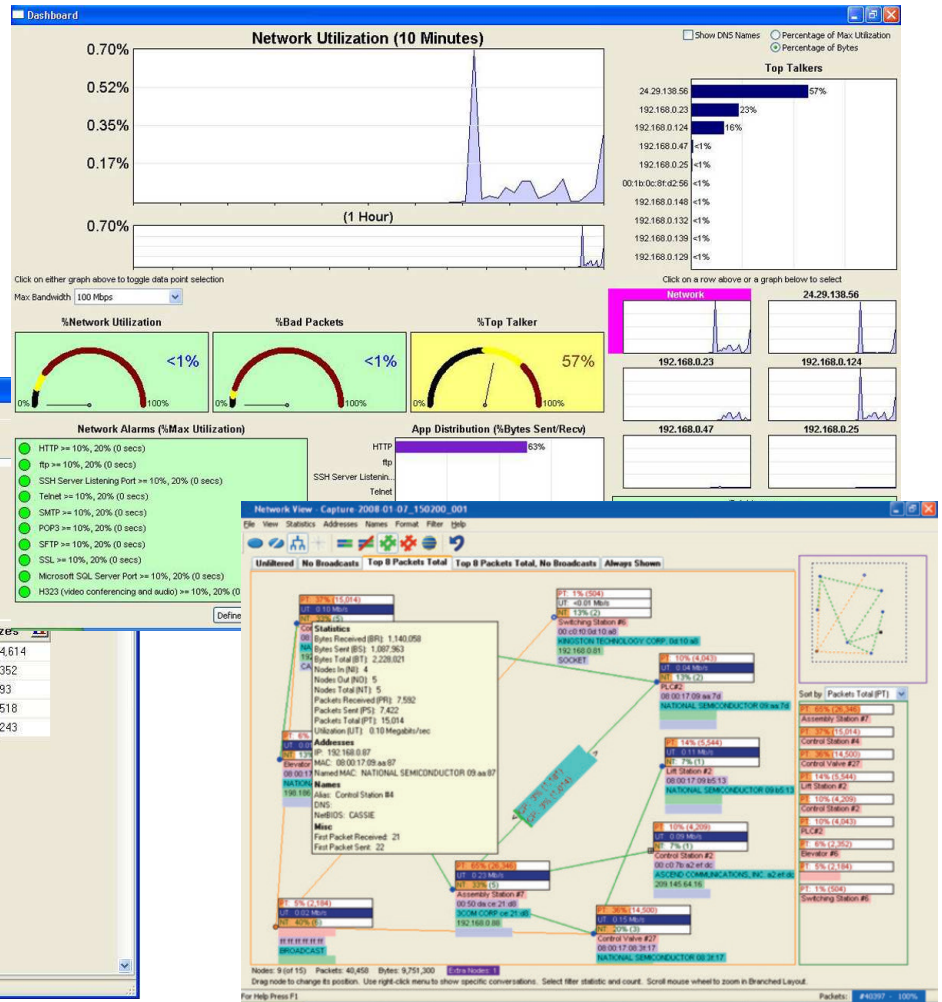

Statistics - Ethertest Demo

Session | Resettable | Buffer

Statistics for the current buffer

Utilization		Frames / Sec		Bytes / Sec	
Current	0%	Current	0	Speed	10 Mbits
Average	2%	Average	138	Current	0
Peak	11%	Peak	549	Average	33,627
7/18/2007 8:22:16 AM		7/18/2007 8:22:16 AM		Peak	138,810
				7/18/2007 8:22:16 AM	

Data	Unfiltered Data	Frame Sizes	
Frames	Rx Frames W/O Errors	64-254	4,614
Bytes	Tx Frames W/O Errors	255-511	352
Events	Total Frames	512-1023	93
Broadcast	Bytes	1024-1518	518
	Multicast Frames	Average Size	243
	Broadcast Frames		

Buffer Information		Errors	
Driver Buffer Overflow	0	CRC Errors	0
Frames Missed, No Buffer	n/a	Alignment Errors	2
Receive Overrun	n/a	Rx Frames With Errors	2
Frames Lost	0	Tx Frames With Errors	n/a
		Tx One Collision	n/a
		Tx More Collisions	n/a
		Tx Deferred	n/a
		Tx Max Collisions	n/a
		Tx Underrun	n/a

Ordering Information

Product Description / Developer Configuration
Free with the purchase of the Ethernet ComProbe

Product Code
2014-21000-000

To order or for more information:

www.fte.com
frontline_online@teledyne.com
1.800.359.8570 • US & Canada +1.434.984.4500 • Fax: 434.984.4505



© 2020 Teledyne LeCroy Inc. All rights reserved. Specifications, prices, availability and delivery subject to change without notice. Product brand or brand names are trademarks or requested trademarks of their respective holders.