

Tektronix®

**TM 5006
POWER MODULE**

Français

Deutsch

日本語

INSTRUCTION MANUAL



**PLEASE CHECK FOR CHANGE INFORMATION
AT THE REAR OF THIS MANUAL.**

TM 5006 POWER MODULE

Francais Deutsch 日本語

INSTRUCTION MANUAL

**Tektronix, Inc.
P.O. Box 500
Beaverton, Oregon 97077**

**070-2950-00
Product Group 76**

Serial Number _____

**First Printing JAN 1981
Revised OCT 1987**

Copyright © 1981 Tektronix, Inc. All rights reserved. Contents of this publication may not be reproduced in any form without the written permission of Tektronix, Inc.

Products of Tektronix, Inc. and its subsidiaries are covered by U.S. and foreign patents and/or pending patents.

TEKTRONIX, TEK, SCOPE-MOBILE, and  are registered trademarks of Tektronix, Inc.

Printed in U.S.A. Specification and price change privileges are reserved.

Copyright © 1981 durch Tektronix, Inc. Alle Rechte vorbehalten. Der Inhalt dieser Publikation darf ohne Genehmigung von Tektronix, Inc. nicht weitergegeben werden.

Produkte von Tektronix, Inc. und seinen Tochtergesellschaften sind durch US- und Auslandspatente und/oder schwebende Patente abgedeckt.

TEKTRONIX, TEK, SCOPE-MOBILE und  sind geschützte Warenzeichen von Tektronix, Inc.

Gedruckt in U.S.A. Spezifikations- und Preisänderungen bleiben vorbehalten.

Copyright © 1981 TEKTRONIX INC. Tous droits réservés. Le contenu de ce manuel ne peut être reproduit sous quelque forme que ce soit sans l'accord de Tektronix Inc.

Tous les produits TEKTRONIX sont brevetés US et Etranger et les logotypes TEKTRONIX, TEK SCOPE MOBILE,  sont déposés.

Imprimé aux USA. TEKTRONIX se réserve le droit de modifier : caractéristiques et prix dans le cadre de développements technologiques.

©1981 年版權所有テクトロニクス社。不許複製。

TEKTRONIX、TEK、SCOPE-MOBILE、
 はテクトロニクス社の登録商標です。

米国にて印刷。仕様及び価格は予告なく変更する場合があります。

INSTRUMENT SERIAL NUMBERS

Each instrument has a serial number on a panel insert, tag, or stamped on the chassis. The first number or letter designates the country of manufacture. The last five digits of the serial number are assigned sequentially and are unique to each instrument. Those manufactured in the United States have six unique digits. The country of manufacture is identified as follows:

B000000	Tektronix, Inc., Beaverton, Oregon, USA
100000	Tektronix Guernsey, Ltd., Channel Islands
200000	Tektronix United Kingdom, Ltd., London
300000	Sony/Tektronix, Japan
700000	Tektronix Holland, NV, Heerenveen, The Netherlands

LANGUAGES

INSTRUCTIONS D'UTILIZATION

BEDIENUNGSALLEITUNG

取扱説明

FRANCAIS

DEUTSCH

日本語

TABLE OF CONTENTS

	Page		Page
LIST OF ILLUSTRATIONS	iv	Table Top Use	2-1
LIST OF TABLES	v	Rackmounting Instructions	2-1
OPERATORS SAFETY SUMMARY	vi	Plug-in Installation and Removal ...	2-3
SERVICE SAFETY SUMMARY	vii	Family Compatibility	2-3
		Customizing the Interface	2-3
Section 1 SPECIFICATION		Rear Panel	2-6
Instrument Description	1-1	Option 02	2-6
Performance Conditions	1-1	Repackaging Information	2-6
Electrical Characteristics	1-1		
Environmental Characteristics	1-4	Chapitre 2 INSTRUCTIONS D'UTILISATION	
Physical Characteristics	1-5	Introduction	2-1
		Source d'alimentation	2-1
Section 2 OPERATING INSTRUCTIONS		Remplacement d'un fusible	2-1
Introduction	2-1	Câblage.....	2-1
Power Source Requirements	2-1	Utilisation sur une table de travail	2-1
Fuse Replacement	2-1	Montage en baie.....	2-1
Cabling	2-1	Installation et retrait des tiroirs.....	2-3
		Compatibilité avec les autres familles.....	2-3
		Personnalisation de l'interface.....	2-6
		Panneau arrière.....	2-6
		Option 02	2-6
		Instructions de réemballage.....	2-6

TABLE OF CONTENTS (CONT)

	Seite		Page
Kapitel 2 BEDIENUNGSANLEITUNG		Section 3 THEORY OF OPERATION	
Einführung	2-1	Introduction	3-1
Netzspannungsversorgung	2-1	Line Selector and 60 Hz Transformer 1	3-1
Auswechseln der Sicherung	2-1	Rectifiers and Filters 1	3-1
Verkabelung	2-1	20 kHz Output Stage 1	3-1
Tischbetrieb	2-1	Control Logic and Drivers 2	3-1
Anleitung für den Gestelleinbau	2-1	Output Regulator 2	3-3
Ein- und Ausbau von Einschüben	2-3	Overvoltage and Overcurrent Detectors 2	3-4
Kompatibilität	2-3	Control Circuit Regulator 2	3-4
Anpassung der Schnittstelle	2-3	Main Interface 3	3-5
Geräterückseite	2-6		
Option 02	2-6	Section 4 CALIBRATION	
Versandhinweise	2-6	Performance Check Procedure	4-1
		Introduction	4-1
第 2 章 取扱説明		Test Equipment Required	4-1
はじめに	2 - 1	Test Loads for the Performance Check Procedure	4-1
電源	2 - 1	Performance Check Summary Sheet	4-2
ヒューズ交換	2 - 1	Internal Adjustment Procedure	4-5
ケーブルの接続	2 - 1	Introduction	4-5
机上でのご使用に	2 - 1	Services Available	4-5
ラックへの取り付け	2 - 1	Test Equipment Required	4-5
プラグインの取り付けと取り外し	2 - 3	Adjustment Access	4-5
プラグイン規格	2 - 3	Power Limit Adjustment	4-5
インターフェイス機能	2 - 3		
後部パネル	2 - 6	Section 5 MAINTENANCE	
オプション02型	2 - 6	Line Voltage Selection	5-1
再梱包の方法	2 - 6	Static Sensitive Components	5-1
		Cleaning	5-2
		Obtaining Replacement Parts	5-2
		Soldering Techniques	5-3
		Semiconductors	5-3
		Multipin Connectors	5-3
		Instrument Disassembly	5-3
		Circuit Troubleshooting	5-5
		Rear Interface Information	5-10
		PWR Indicator	5-10
		Pin Assignments	5-10

WARNING

The following servicing instructions are for use by qualified personnel only. To avoid personal injury, do not perform any servicing other than that contained in operating instructions unless you are qualified to do so.

TABLE OF CONTENTS (cont)

	Page
Section 6 OPTIONS	
Introduction	6-1
Option 02	6-1
System Design Directions	6-1
Wire Use	6-1
 Section 7 REPLACEABLE ELECTRICAL PARTS	
 Section 8 DIAGRAMS AND CIRCUIT BOARD ILLUSTRATIONS	
Component Reference Charts	
Schematic Diagrams	
 Section 9 REPLACEABLE MECHANICAL PARTS	
Fig. 1 Exploded View	
Accessories	
 CHANGE INFORMATION	

LIST OF ILLUSTRATIONS

Fig. No.	Page	Fig. No.	Page
		5-4	Outer panel removal 5-4
2-1	TM 5006 Power Module viii	5-5	Guide rail and air baffle removal 5-4
2-2	TM 5006 rear panel 2-2	5-6	Removal of interface circuit board support 5-5
2-2	TM 5006 front view 2-3	5-7	Main interface circuit board removal 5-6
2-3	TM 5006 bottom view 2-4	5-8	Rear panel removal 5-6
2-4	TM 5006, Option 10 overall dimensions 2-5	5-9	Location of screws holding the dc power supply circuit board to the mainframe chassis 5-7
2-5	Rack latch hole 2-6	5-10	Attaching screws on bottom of mainframe 5-7
2-6	Dimensions and positioning of TM 5006, Option 10, in standard rack 2-7	5-11	Unsolder these wires to remove heat sink 5-8
2-7	Rackmount slide detail. If the rack has tapped holes, the bar nuts are not required 2-8	5-12	Series pass transistor locations. The high power compartment series pass transistors Q600 and Q610 are on the right side of the heat sink. Q600 is the upper transistor 5-9
2-8	Rackmounting slide details 2-8	5-13	Screws holding heat sink to circuit board 5-9
2-9	Removing and installing TM 5006, Option 10, in rack slides 2-9	5-14	Transformer assembly attaching screws 5-9
2-10	Plug-in installation and removal 2-10	5-15	PWR signal timing diagram 5-10
2-11	Keying assignments for family functions. One of the many possible sequence combinations 2-10	5-16	Rear interface connector assignments 5-11
3-1	Various waveforms and time relationships for power on, off, fault, and low line 3-2	5-17	Rear panel GPIB connector J1110 viewed from rear of power module (IEEE Standard No. 488) 5-12
3-2	Input line connections for 110 V and 220 V operation 3-3	8-1	Dc power supply board (A11)
4-1	Possible loads for use in performance check procedure. See text. 4-1	8-2	Dc power supply regulator waveforms
4-2	Test setup for performance check steps 1, 2 and 3 and location of connections for adjustment step 1 4-4	8-3	Main interface board (A10)
4-3	Loads for use in internal adjustment procedure 4-5	8-4	GPIB interconnect board (A16 back side)
4-4	Adjustment location illustration 4-6		
4-5	Location of voltage buses 4-6		
5-1	Line cord options for the TM 5006 5-1		
5-2	Line voltage jumper positions 5-2		
5-3	Orientation and disassembly of multipin connectors 5-3		

LIST OF TABLES

Table No.		Page
1-1	Electrical Characteristics	1-1
1-2	Environmental Characteristics	1-4
1-3	Physical Characteristics	1-5
4-1	Suggested Test Equipment	4-3
5-1	Relative Susceptibility to Static Discharge Damage	5-2
8-1	Partial A11 Component Reference Chart	
8-2	Partial A11 Component Reference Chart	
8-3	A10 Component Reference Chart	

OPERATORS SAFETY SUMMARY

The general safety information in this part of the summary is for both operating and servicing personnel. Specific warnings and cautions will be found throughout the manual where they apply, but may not appear in this summary.

Terms In This Manual

CAUTION statements identify conditions or practices that could result in damage to the equipment or other property.

WARNING statements identify conditions or practices that could result in personal injury or loss of life.

Terms As Marked on Equipment

CAUTION indicates a personal injury hazard not immediately accessible as one reads the marking, or a hazard to property including the equipment itself.

DANGER indicates a personal injury hazard immediately accessible as one reads the marking.

Symbols In This Manual



This symbol indicates where applicable cautionary or other information is to be found.

Symbols As Marked on Equipment



DANGER — High voltage.



Protective ground (earth) terminal.



ATTENTION — refer to manual.

Power Source

This product is intended to operate from a power source that will not apply more than 250 volts rms between the supply conductors or between either supply conductor

and ground. A protective ground connection by way of the grounding conductor in the power cord is essential for safe operation.

Grounding the Product

This product is grounded through the grounding conductor of the power cord. To avoid electrical shock, plug the power cord into a properly wired receptacle before connecting to the product input or output terminals. A protective ground connection by way of the grounding conductor in the power cord is essential for safe operation.

Danger Arising From Loss of Ground

Upon loss of the protective-ground connection, all accessible conductive parts (including knobs and controls that may appear to be insulating) can render an electric shock.

Use the Proper Fuse

To avoid fire hazard, use only the fuse of correct type, voltage rating and current rating as specified in the parts list for your product.

Refer fuse replacement to qualified service personnel.

Do Not Operate in Explosive Atmospheres

To avoid explosion, do not operate this product in an explosive atmosphere unless it has been specifically certified for such operation.

Do Not Operate Without Covers

To avoid personal injury, do not remove the product covers or panels. Do not operate the product without the covers and panels properly installed.

SERVICE SAFETY SUMMARY

FOR QUALIFIED SERVICE PERSONNEL ONLY

Refer also to the preceding Operators Safety Summary.

Do Not Service Alone

Do not perform internal service or adjustment of this product unless another person capable of rendering first aid and resuscitation is present.

Use Care When Servicing With Power On

Dangerous voltages exist at several points in this product. To avoid personal injury, do not touch exposed connections and components while power is on.

Disconnect power before removing protective panels, soldering, or replacing components.

Power Source

This product is intended to operate from a power source that will not apply more than 250 volts rms between the supply conductors or between either supply conductor and ground. A protective ground connection by way of the grounding conductor in the power cord is essential for safe operation.

RECAPITULATIF DES CONSIGNES DE SECURITE

Termes utilisés dans ce manuel

Les paragraphes intitulés ATTENTION identifient les circonstances ou opérations pouvant entraîner la détérioration de l'appareil ou de tout autre équipement.

Les paragraphes intitulés AVERTISSEMENT indiquent les circonstances dangereuses pour l'utilisateur (danger de mort ou risque de blessure).

Repères gravés sur l'appareil

CAUTION (ATTENTION) : ce mot identifie les zones de risque de blessure non perceptibles immédiatement ou un risque éventuel de détérioration de l'appareil.

DANGER (DANGER) : ce mot indique les zones de risque immédiat pouvant entraîner blessures ou mort.

Symboles gravés sur l'équipement



DANGER – Haute tension



Borne de masse de protection (terre)



ATTENTION – se reporter au manuel

Source d'alimentation

L'appareil est conçu pour fonctionner à partir d'une source d'alimentation maximale de 250 V efficaces entre les conducteurs d'alimentation ou entre chaque conducteur d'alimentation et la terre. Pour utiliser l'appareil en toute sécurité, une connexion à la masse, réalisée au moyen d'un conducteur prévu dans le cordon d'alimentation, est indispensable.

Mise à la masse de l'appareil

Une fois installé dans le châssis d'alimentation, l'appareil est relié à la masse à l'aide d'un conducteur du cordon d'alimentation. Pour éviter tout choc électrique, insérer la prise du cordon d'alimentation dans une prise de distribution correspondante avant de connecter l'entrée ou les sorties de l'appareil. Pour utiliser l'appareil en toute sécurité, une connexion à la masse réalisée au moyen d'un conducteur prévu dans le cordon d'alimentation, est indispensable.

Danger provoqué par la coupure de connexion de masse

En cas de coupure de la connexion de masse, tous les éléments conducteurs accessibles (y compris boutons et commandes apparaissant isolants) peuvent provoquer un choc électrique.

Utiliser le cordon d'alimentation approprié

N'utiliser que le cordon d'alimentation et la prise recommandés pour votre appareil. Utiliser un cordon d'alimentation en parfait état. Seul, un personnel qualifié peut procéder à un changement de cordon et prises.

Utiliser le fusible approprié

Pour éviter tout risque d'accident (incendie...) n'utiliser que le fusible recommandé pour votre appareil. Le fusible de remplacement doit toujours correspondre au fusible remplacé : même type, même tension et même courant. Un remplacement de fusible ne doit être effectué que par un personnel qualifié.

Ne pas utiliser l'appareil en atmosphère explosive

Pour éviter toute explosion, ne pas utiliser cet appareil dans une atmosphère de gaz explosifs.

Ne pas démonter les capots

Pour éviter toute blessure, ne pas utiliser cet appareil sans capots ou panneaux. Ne pas alimenter le tiroir à travers un prolongateur.

CONSIGNES DE SECURITE

UNIQUEMENT DESTINEES AU PERSONNEL DE MAINTENANCE

Ne dépannez pas seul

Ces consignes s'adressent exclusivement à un personnel qualifié. Il est également indispensable de se reporter aux consignes de sécurité précédentes. Toute intervention interne ou réglage doit s'effectuer en présence d'une autre personne capable d'assurer les premiers secours en cas de danger.

Agir avec précaution lorsque l'appareil est sous tension

Des potentiels dangereux existent en différents points de l'appareil. Pour éviter toute blessure, ne pas intervenir sur les connexions et les composants alors que l'appareil est sous

tension. Débrancher l'alimentation avant le démontage des panneaux, soudure ou remplacement de composants.

Source d'alimentation

Cet appareil est conçu pour fonctionner à partir d'une source d'alimentation qui n'applique pas plus de 250 V efficaces entre les conducteurs d'alimentation ou entre un conducteur et la masse. Pour utiliser l'appareil en toute sécurité, une connexion à la masse réalisée au moyen d'un conducteur prévu dans le cordon d'alimentation est indispensable.

SICHERHEITSANGABEN FÜR DEN ANWENDER

Die allgemeinen Sicherheitsinformationen in diesem Teil der Angaben dienen dem Anwender- und Servicepersonal. Spezielle Warnungen und Hinweise sind überall im Handbuch zu finden, müssen jedoch in diesen Angaben nicht erscheinen.

BEGRIFFE

In diesem Handbuch

VORSICHTSHINWEISE erläutern Bedingungen, die zur Zerstörung des Gerätes oder anderer Gegenstände führen können.

WARNUNGSHINWEISE erläutern Bedingungen, die zu Personenschäden führen können oder lebensgefährlich sind.

Markierungen auf dem Gerät

CAUTION - VORSICHT weist darauf hin, daß durch zufälliges Berühren an einer nicht unmittelbar zugänglichen Stelle Personenschaden entstehen kann, oder Schaden am Gerät selbst.

DANGER - GEFAHR weist darauf hin, daß durch zufälliges Berühren an einer zugänglichen Stelle Personenschaden entstehen kann.

SYMBOLE

In diesem Handbuch



Dieses Symbol zeigt an, wo Vorsicht walten zu lassen ist, oder wo Informationen zu finden sind.

Markierungen auf dem Gerät



GEFAHR - Hochspannung.



Schutzerdungskontakt.



ACHTUNG - beziehen Sie sich auf das Handbuch.

Netzspannungsversorgung

Die Betriebsspannung für dieses Gerät darf 250 V_{eff} nicht überschreiten und ist an die Versorgungsleitungen bzw. an eine Versorgungsleitung und Masse anzulegen. Innerhalb des Netzanschlußkabels muß ein Schutzleiter vorhanden sein, der mit Gerätemasse verbunden ist.

Masseanschluß des Gerätes

Dieses Gerät wird über den Schutzleiter der Versorgungseinheit mit Erdpotential verbunden. Zur Vermeidung

von elektrischen Schlägen vor der Beschaltung der Ein- und Ausgänge ist der Netzstecker in eine korrekt verdrahtete Steckdose einzustecken. Verwenden Sie den Schutzleiter nicht als einzige Verbindung zwischen zwei oder mehreren Geräten. Zur Vermeidung von elektrischen Schlägen sind die Geräte untereinander mit separaten Leitungen zu verbinden.

Gefahr durch fehlende Schutzterde

Durch eine fehlende Schutzterde können alle berührbaren, leitenden Teile (einschließlich Knöpfe und andere Bedienungselemente, die isoliert sind) einen elektrischen Schlag bei der Berührung auslösen.

Verwendung eines richtigen Netzkabels

Verwenden Sie nur Netzkabel, die für die Versorgungseinheit geeignet sind und die sich in gutem Zustand befinden.

Für detaillierte Informationen über Kabel und Stecker beziehen Sie sich bitte auf Abbildungen innerhalb des Handbuches.

Ein Austausch von Kabeln und Steckern ist nur von geschultem Personal vorzunehmen.

Verwendung einer richtigen Sicherung

Zur Vermeidung von Brandschäden sind nur Sicherungen zu verwenden, die in den Teilelisten dieses Gerätes aufgeführt sind und die in Spannungs- und Stromwert entsprechend sind.

Ersatz von Sicherungen ist nur von geschultem Personal vorzunehmen.

Arbeiten Sie nicht in explosiver Umgebung

Zur Vermeidung von Explosionen ist die Inbetriebnahme dieses Gerätes in explosiver Umgebung zu unterlassen, wenn das Gerät nicht dafür geeignet ist.

Entfernen Sie keine Gehäuseabdeckungen

Zur Vermeidung von Personenschäden sind keine Gehäuseteile zu entfernen. Auch ist das Gerät ohne Gehäuse nicht in Betrieb zu nehmen.

Arbeiten Sie nicht ohne Gehäuseabdeckung

Zur Vermeidung von Personenschäden ist das Gerät nicht ohne Gehäuse in Betrieb zu nehmen. Der Einschub sollte nicht über einen Verlängerungsadapter betrieben werden.

SICHERHEITSAANGABEN FÜR DEN SERVICE

NUR FÜR GESCHULTES PERSONAL

Beziehen Sie sich auch auf die vorangehenden Sicherheitsangaben für den Anwender.

Führen Sie keine Servicetätigkeiten alleine durch

Nehmen Sie an dem Gerät keine Service- oder Einstellarbeiten vor, wenn nicht eine andere Person verfügbar ist, um im Bedarfsfall Erste Hilfe oder Wiederbelebungsversuche zu leisten.

Lassen Sie besondere Vorsicht walten, wenn Sie an einem unter Spannung stehenden Gerät arbeiten

An verschiedenen Stellen im Gerät liegen hohe und damit gefährliche Spannungen. Zur Vermeidung von Personen-

schäden sind solche Stellen und Bauteile nicht zu berühren, während Betriebsspannung anliegt.

Vor dem Entfernen von Gehäuseteilen, Löten oder Ersetzen von Bauteilen ist immer die Betriebsspannung zu entfernen.

Netzspannungsversorgung

Die Betriebsspannung für dieses Gerät darf $250 V_{eff}$ nicht überschreiten und ist an die Versorgungsleitungen bzw. an eine Versorgungsleitung und Masse anzulegen. Innerhalb des Netzanschlußkabels muß ein Schutzleiter vorhanden sein, der mit Gerätemasse verbunden ist.

ご使用の前に

機器の操作、保守、修理のすべての面で安全にご使用いただくため次の2項の注意および手順をお守り下さい。

安全なご使用のために

この項目では操作する人およびサービス・エンジニアの方に安全にお取扱いいただくための注意事項が述べられています。

用語

マニュアル中の用語

注意の項は本機器または他の接続機器に損傷を及ぼす恐れのある場合の注意です。

警告の項は人体に損傷を与えたり生命に危険を及ぼす恐れのある場合の注意です。

機器上に記されている用語

CAUTIONは人体および本機器または周辺機器に損傷を及ぼす恐れがある部分を示しています。

DANGERは人体に損傷を及ぼしたり生命に危険を与える恐れがある部分を示しています。

記号

この取扱説明書に出てくる記号



このマークは適切な注意、または他の項目を参照する必要がある場合を指示しています。

機器に記された記号



危険——高電圧



保護用接地端子



注意——取扱説明書参照

電源

本機器は電源コードの線間、あるいは電源コードとグラウンド間が250Vrms以内の範囲の電源で作動します。安全のために電源コードのアース線で接地して下さい。

機器の接地

本機器は電源コードのアース線で接地されます。電氣的ショックを避けるために、電源コードをコンセントに差し込んでから、機器の入、出力端子への接続を行って下さい。電源コード中のアース線は必ず接地して下さい。

電源本体の接地

電氣的ショックを防止するため、電源本体は確実に接地して下さい。接地が行われていないと、導体の部品（絶縁処理されたノブおよびコントロールつまみを含む。）により電氣的ショックを受けることがあります。

電源コード

電源コードとコネクタは機器に適合するものをお使い下さい。

電源コードに損傷がないことをお確かめ下さい。

電源コードとコネクタに関する詳細は本体取扱説明書をご参照下さい。

電源コードとコネクタの交換については当社エンジニアにおたずね下さい。

ヒューズ

危険防止のため、マニュアルに記載されている仕様に適合するヒューズをご使用下さい。

ヒューズの交換に関する詳細は、当社フィールド・エンジニアにおたずね下さい。

爆発防止

危険防止のため、爆発性のガスが周囲にあるような所では作動させないで下さい。

カバー、パネルについて

プラグインのカバーやパネルを取りはずしたまま作動させないで下さい。

修理上の注意

サービス・エンジニアの方へ

“操作上の注意”を先にお読み下さい。

1人でサービスを行わないで下さい。

機器の内部点検または修理は、万一の場合に備えて応急処置のできる人がいる所で行って下さい。

電源を入れた場合の注意

機器内部には高電圧の部分があります。人体への危険を防止するため、電源がはいっている時は、露出している接続部分や部品には手を触れないで下さい。

パネルの取りはずし、ハンダ付、部品の交換を行う前には、電源を必ず切って下さい。

電源

本機器は電源コードの線間、あるいは電源コードとグラウンド間が250Vrms 以内の範囲の電源で作動します。安全のために電源コードのアース線できちんと接地して下さい。

TM 5006

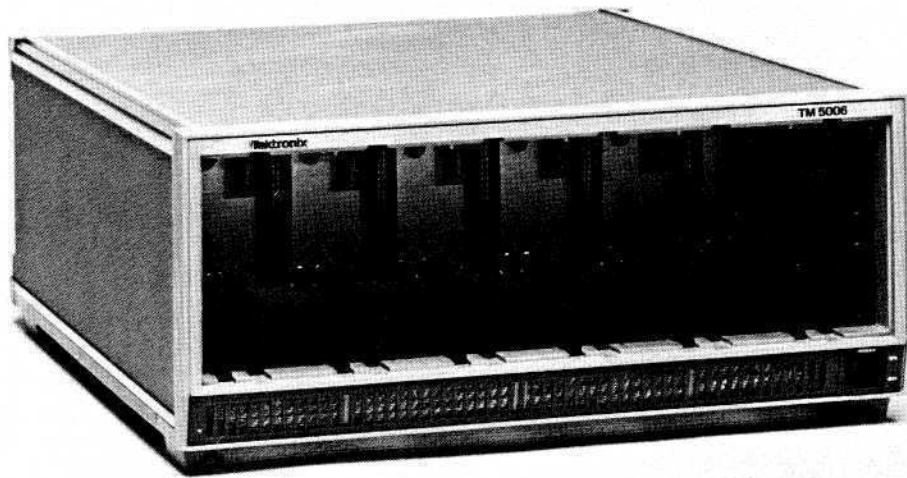

2950-00

TM 5006 Power Module.

SPECIFICATION

Instrument Description

The TM 5006 is a six-compartment power module compatible with TM 500/TM 5000-Series plug-ins. The power module features a pulse width modulated switching dc power supply. All dc voltages are regulated. The right compartment is the high power compartment. The unit has forced air cooling.

Six individual connectors, one for each compartment, provide connections to each GPIB compatible plug-in. These connectors feed to a GPIB interface board, then to a standard GPIB connector on the rear panel. All GPIB connections are separate from the board rear interface connector.

Performance Conditions

The electrical characteristics in this specification are valid only if the TM 5006 has been adjusted at an ambient

temperature between +20°C and +30°C. The instrument must be in a non-condensing environment whose limits are described under the environmental part. Allow 30 minutes warm-up time for operation to specified accuracy; 60 minutes after exposure to or storage in a high humidity (condensing) environment. Any conditions that are unique to a particular characteristic are expressly stated as part of that characteristic.

The electrical and environmental performance limits, together with their related validation procedures, comprise a complete statement of the electrical and environmental performance of a calibrated instrument.

Items listed in the Performance Requirements column of the Electrical Characteristics are verified by completing the Performance Check in the Calibration section of this manual. Items listed in the Supplemental Information column are not verified in this manual.

Table 1-1

ELECTRICAL CHARACTERISTICS

Characteristics	Performance Requirements	Supplemental Information
SUPPLIES		
+26 V dc		
Tolerance ^a	+23.7 V to +28.3 V	
PARD ^b		≤ 2.5 V peak to peak
Maximum load		1 A per compartment
Maximum load $\frac{di}{dt}$		10 mA/ μ s
-26 V dc		
Tolerance ^a	-23.7 V to -28.3 V	
PARD ^b		≤ 2.5 V peak to peak
Maximum load		1 A per compartment
Maximum load $\frac{di}{dt}$		10 mA/ μ s

Table 1-1 (cont)

Characteristics	Performance Requirements	Supplemental Information
+8 V dc		
Tolerance ^a	+7.6 V to +8.5 V	
PARD ^b		≤ 600 mV peak to peak
Maximum load		
Standard compartment		3 A per compartment
High power compartment		3 A per compartment
Maximum load $\frac{di}{dt}$		20 mA/μs
25 V ac (2 each compartment)		
Range		26.0 V rms +10%, -15% floating
Maximum load		
Standard compartment		1 A rms per winding
High power compartment		2.5 A rms per winding
Maximum floating voltage		350 V peak from chassis ground
17.5 V ac		
Range		20.5 V +10%, -20% with grounded center tap
Maximum load		350 mA per compartment
Maximum plug-in power ^c draw from mainframe		
Standard compartment		30 watts dc or 50 VA ac
High power compartment		30 watts dc or 125 VA ac
Combined power draw ^c sharing limitation		
Standard compartment		VA ac +2.67 (watts dc) ≤ 100
High power compartment		VA ac +2.67 (watts dc) ≤ 150
	SERIES PASS TRANSISTORS	
Type		One NPN and PNP per compartment
Maximum dissipation		
Standard compartment		10 W each, 20 W total
High power compartment		30 W each, 50 W total
Maximum floating voltage		350 V peak

Table 1-1 (cont)

Characteristics	Performance Requirements	Supplemental Information
	SOURCE POWER REQUIREMENTS	
Voltage Ranges		Selectable (nominal): 100 V, 110 V, 120 V, 200 V, 220 V, and 240 V. (250 V maximum on 240 V range)
Tolerance		+7% – 10%
Line Frequency		48 Hz to 66 Hz
Maximum power consumption		650 VA
Fuse Data		
100 V, 110 V, 120 V ranges		7 A, 3 AG, medium blow
200 V, 220 V, 240 V ranges		4 A, 3 AG, fast blow
	MISCELLANEOUS	
Maximum recommended plug-in power dissipation		
One-wide		15 W
Two-wide		35 W
Recommended adjustment interval		1000 hours or 6 months

• Worst case: Low line with full load and high line with no load. These limits include PARD.

▫ Periodic and Random Deviation. See National Electrical Manufacturers Association (NEMA) Standards Publication No. PY1-1972.

° At nominal line voltage.

Table 1-2

ENVIRONMENTAL CHARACTERISTICS ^a

Characteristics	Description	
Temperature	Meets MIL-T-28800B, class 5.	
Operating ^b	0°C to +50°C	
Non-operating	-55°C to +75°C	
Humidity ^b	95% RH, 0°C to 30°C 75% RH, to 40°C 45% RH, to 50°C 95% RH, to 50°C Extended qualification.	Exceeds MIL-T-28800B, class 5.
Altitude	Exceeds MIL-T-28800B, class 5.	
Operating ^b	4.6 Km (15,000 ft.)	
Non-operating	15 Km (50,000 ft.)	
Vibration ^c	0.38 mm (0.015") peak to peak, 5 Hz to 55 Hz, 75 minutes.	Exceeds MIL-T-28800B, class 5.
Shock ^c	30 g's (1/2 sine), 11 ms duration, 3 shocks in each direction along 3 major axes, 18 total shocks.	Meets MIL-T-28800B, class 5.
Bench Handling ^c	12 drops from 45°, 4" or equilibrium, whichever occurs first.	Meets MIL-T-28800B, class 5.
Transportation ^d	Qualified under National Safe Transit Association Preshipment Test Procedures 1A-B-1 and 1A-B-2.	
EMC	Within limits of MIL-461A tests RE02; CE01 ^e ; CE03; RS01; CS01, and CS02.	
Electrical Discharge	20 kV maximum charge applies to instrument case.	

^a System environmental specifications subject to individual plug-in specifications.

^b Electrical load in accordance with Section 2.2.1.

^c With mechanical load of 19 lbs, ±1 lb. evenly distributed. (Three two-wide plug-ins, each weighing 6 1/3 lbs, ±3 lbs. ±1/3 lb. with two rear support pins and one rear interface ECB). Requires retainer clips.

^d Without mechanical load (plug-ins).

^e Increase first 3 odd power line frequency harmonic amplitudes by 10 dB.

Table 1-3
PHYSICAL CHARACTERISTICS

Characteristics	Description
Maximum recommended plug-in weight	
One wide	1.4 kg (3 lbs.)
Two wide	2.7 kg (6 lbs.)
Net weight (without plug-ins)	14.5 kg (32 lbs.)
Maximum overall dimensions	
Height	193.8 mm (7.63 inches)
Width	444.73 mm (17.509 inches)
Length	476 mm (18.74 inches)
Enclosure type and style per MIL-T-28800B	
TM 5006	
Type	III
Style	E
TM 5006 Option 10 (rackmount)	
Type	III
Style	F
Finish	
Frame	Powder coated aluminum
Covers	Vinyl clad aluminum

OPERATING INSTRUCTIONS

Introduction

The TM 5006 Power Module is calibrated and ready for use when received. A list of standard accessories (and part numbers) is located in the back of this manual.

Power Source Requirements

WARNING

AC POWER SOURCE AND CONNECTION. *This instrument operates from a single-phase power source. It has a three-wire power cord and two-pole, three-terminal grounding-type plug. The voltage to ground (earth) from either pole of the power source must not exceed the maximum rated operating voltage, 250 V.*

Before making connection to the power source, determine that the instrument is adjusted to match the voltage of the power source, and has a suitable two-pole, three-terminal grounding-type plug. Refer any changes to qualified service personnel.

GROUNDING. *This instrument is safety class I equipment (IEC designation). All accessible conductive parts are directly connected through the grounding conductor of the power cord to the grounding contact of the power plug.*

The power input plug must only be inserted in a mating receptacle with a grounding contact. Do not defeat the grounding connection. Any interruption of the grounding connection can create an electric shock hazard.

For electric shock protection, the grounding connection must be made before making connection to the instrument's input or output terminals.

See Fig. 2-1. Refer to the line voltage and fuse data label on the rear panel.

Fuse Replacement

Turn the slotted section of the line fuse holder counterclockwise and remove the fuse. Replace the fuse with the proper type as shown on the rear panel label.

Cabling

CAUTION

Remove power cord before attempting cable installation.

For convenience, cabling from the front of the power module to the rear panel may be run through the air intake

and cable raceway as shown in Fig. 2-2. To install this cabling first remove the access panel on the rear of the power module. See Fig. 2-1. Next remove the two bottom panel retainer screws and the bottom panel retainers. Slide the bottom panel out from the rear of the instrument. Pass the cable through the front air intake, across the bottom of the plug-in support rails and out the access panel. Replace the power module bottom cover.

CAUTION

To ensure proper cooling, do not operate the power module with any cover removed.

Table Top Use

The power module may be operated with the front raised. To raise the front of the instrument extend the front bail as shown in Fig. 2-3.

Rackmounting Instructions

Cooling. Examine the side panels of the TM 5006, Option 10, power module. If there are no cooling holes in the side panels, at least 1-inch clearance must be maintained between the bottom of the power module and the instrument below it. This is necessary to insure proper cooling. If the side panels have cooling holes, no special precautions are necessary.

If the rack has positive internal pressure for cooling purposes, the mainframes must have all compartments filled with plug-ins or blank front panels (available from Tektronix, Inc.) must be installed in the unused plug-in openings. If greater internal air flow is desired in a relatively highly pressurized rack, the grill opening at the bottom front of the TM 5006 may also be blocked.

Rack Dimensions. The TM 5006, Option 10, is shipped from the factory ready for rack mounting. Figure 2-4 shows major dimensions. Figure 2-5 shows the spring-latch cutout in the stationary section.

NOTE

The slide tracks supplied with the TM 5006, Option 10, have holes in the stationary sections to accommodate the spring latches. The TM 5006, Option 10, should not be mounted with rack slides that do not have the rack-latch holes.

The TM 5006, Option 10, fits the standard 19-inch side cabinet, rack or console. Spacing inside the front rails must be at least 17 3/4 inches. This allows clearance for the stationary section of the slide-out tracks to permit the assembly to slide freely on the slid-out tracks.

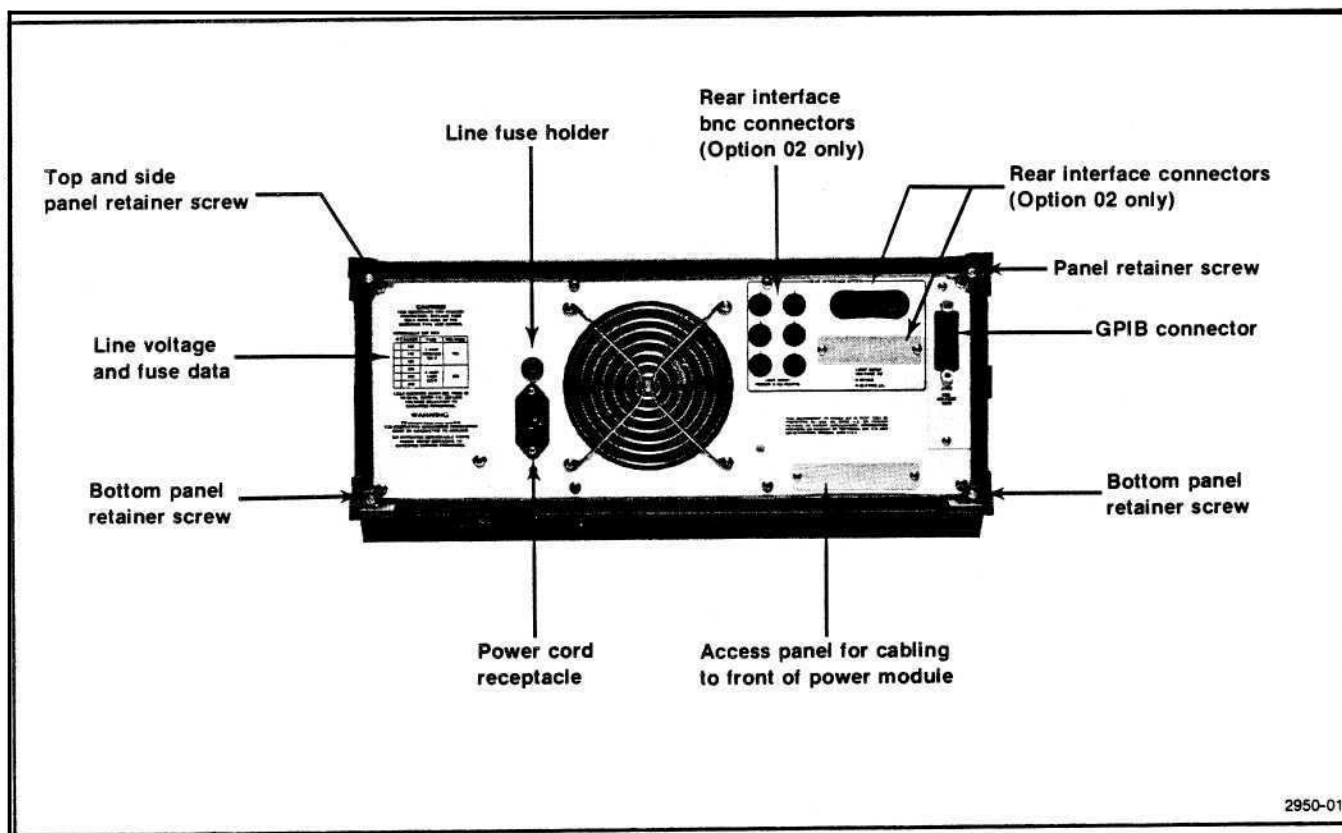

Fig. 2-1. TM 5006 rear panel.

The slide-out tracks, with existing hardware supplied, will conveniently mount in any rack with the front and rear rails spaced from 10 1/2 inches to 24 1/2 inches.

Mounting the Slide Tracks. Locate the proper rack holes for mounting as shown in Fig. 2-6. Notice that the hole spacing in the racks varies. When installing the slides in the EIA type racks, make certain the slides are attached to the 1/2-inch spaced holes. Figure 2-6 also shows details for determining position of the slides in the rack. Mount the rails using enclosed hardware as shown in Figs. 2-7 and 2-8. Figures 2-8B and C show rail-mounting details for deep and shallow racks. Make sure the stationary sections are horizontally aligned so they are level and parallel with each other.

Installing the TM 5006, Option 10, in the Rack Slides. Make certain all plug-ins are removed from the power module. Pull the slide-out track intermediate sections out as far as they will go. See Fig. 2-9. Insert the instrument chassis sections into the intermediate section and push the instrument forward until the instrument chassis section locks into the intermediate section. Now press both buttons protruding from the stop-latch holes in the intermediate sections while pushing the instrument. The instrument can now be pushed into the rack, cabinet, or

console. The latches holding the intermediate sections to the stationary sections are automatically operated by the instrument as it is pushed into the rack or cabinet. The quick-release latches automatically engage the rack-latch holes in the stationary sections of the rails as the instrument is pushed fully into the rack.

Removing the Instrument. Remove all plug-ins from power module. Unscrew the two thumb screws at the top of the front panel. Pull the rectangular latches on both sides of the front panel. Using the latches pull the instrument from the enclosure until the slide intermediate sections latch with the instrument sections and the stationary sections. The instrument is firmly held in this position. To completely remove the instrument, press both release-latch buttons visible in the stop-latch holes and carefully slide the instrument from the rack or cabinet.

Rack Adjustments. After installing the instrument in the rack, binding in the rack slides may occur if the slides are not properly adjusted. Slide the instrument from the rack until the front panel is about 10 inches from the front of the rack. Slightly loosen the screws holding the right and left tracks to the front rails. Allow the tracks to seek their normal position. Retighten the screws and check the tracks for smooth operation by sliding the instrument in and out of the rack.

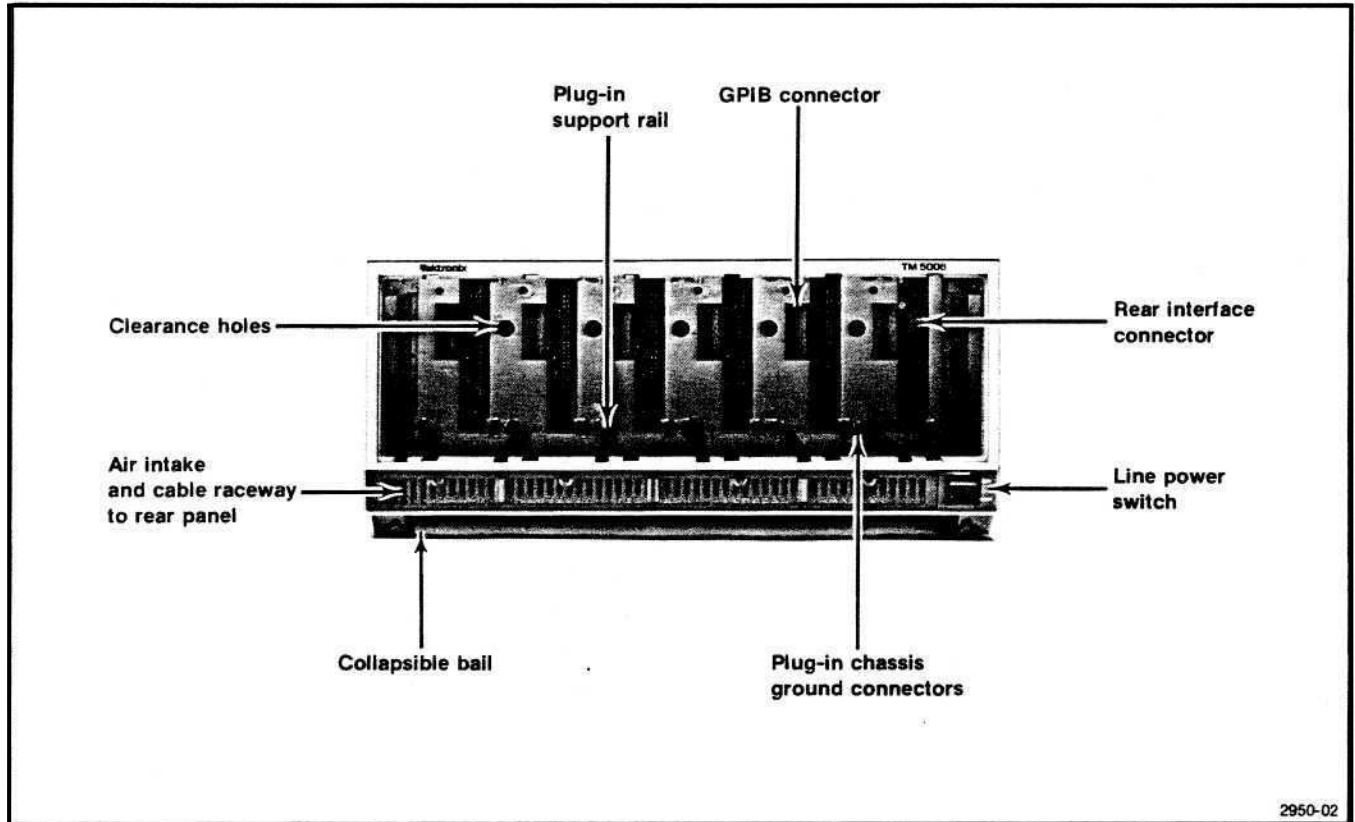

Fig. 2-2. TM 5006 front view.

Rack Slide Maintenance. The slide-out tracks do not require lubrication. The dark gray finish on the tracks is a permanent lubricative coating.

circuit board edge connector in the interconnecting jack. Turn the power module on.

Plug-in Installation and Removal

CAUTION

Turn the power module off before inserting or removing the plug-in; otherwise, damage may occur to the plug-in circuitry.

NOTE

The DC 505, DC 505A and LA501W plug-ins are not compatible with this power module.

Check to see that the plastic barriers on the interconnecting jack of the selected power module compartment match the cutouts in the plug-in circuit board edge connector. The right-most compartment is the high power compartment. Align the plug-in chassis with the upper and lower guides (see Fig. 2-10) of the selected compartment. Push the plug-in chassis in and press firmly to seat the

Family Compatibility

Mechanically, TM 5000 plug-in modules are very similar to other Tektronix product families. However, they are not electrically compatible. Therefore, the TM 5006 interface has barriers on the mating connectors between pins 6 and 7 to ensure that incompatible plug-ins cannot be inserted. See Fig. 2-11. A compatible module will have a matching slot between pins 6 and 7 of its main circuit board edge connector. This slot and barrier combination is the primary keying assignment.

Customizing the Interface

The modularity of this instrumentation system provides for many different functions to be performed by the plug-in modules. Specific functions are grouped into families or classes, of which there may be several plug-in module members. For instance, some classes are Power Supplies, Signal Sources, Measurement, and so forth. Each modular member of a functional family will have a second slot, peculiar to its family assignment, located in its edge connector. The TM 5006 user can select one or more

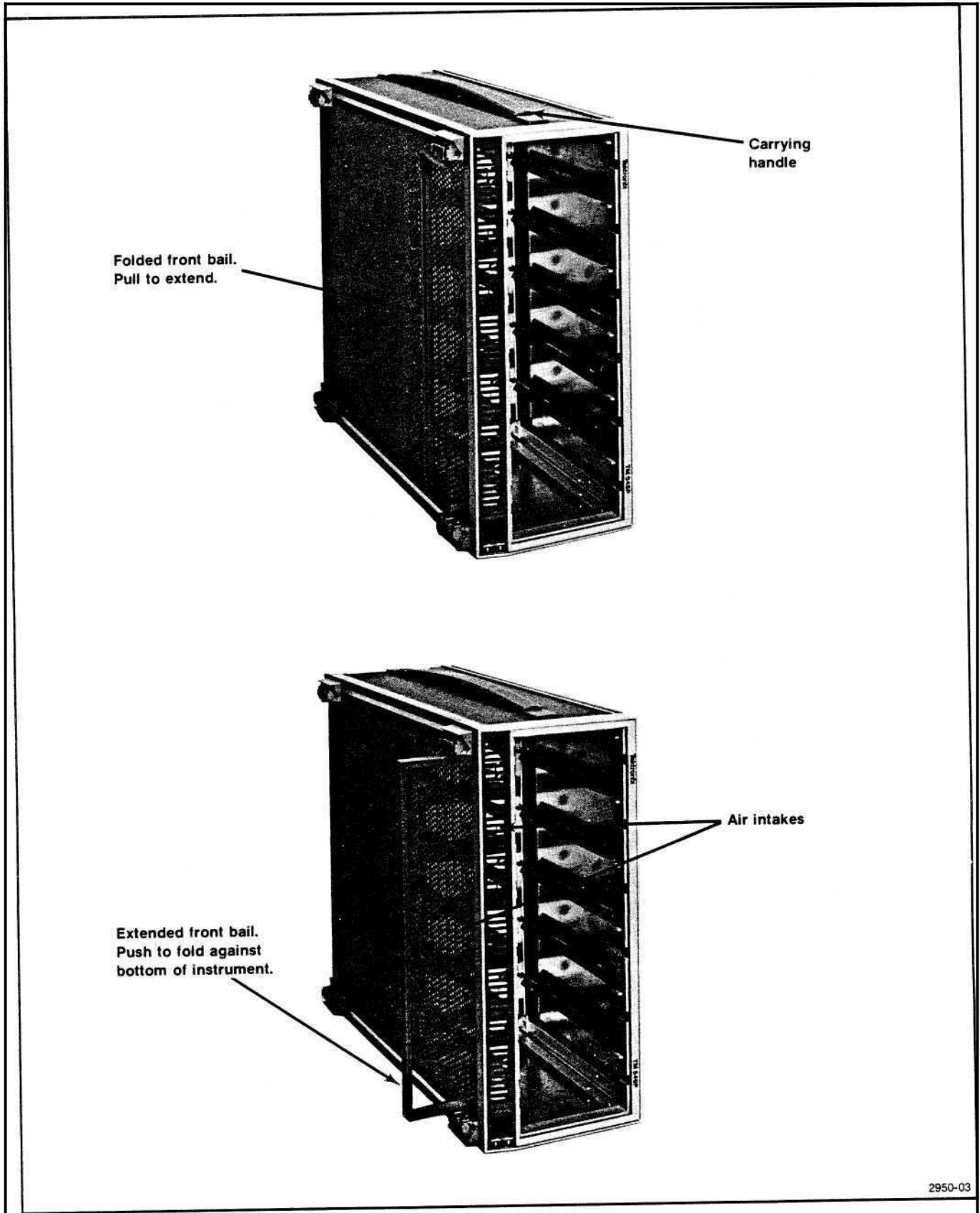
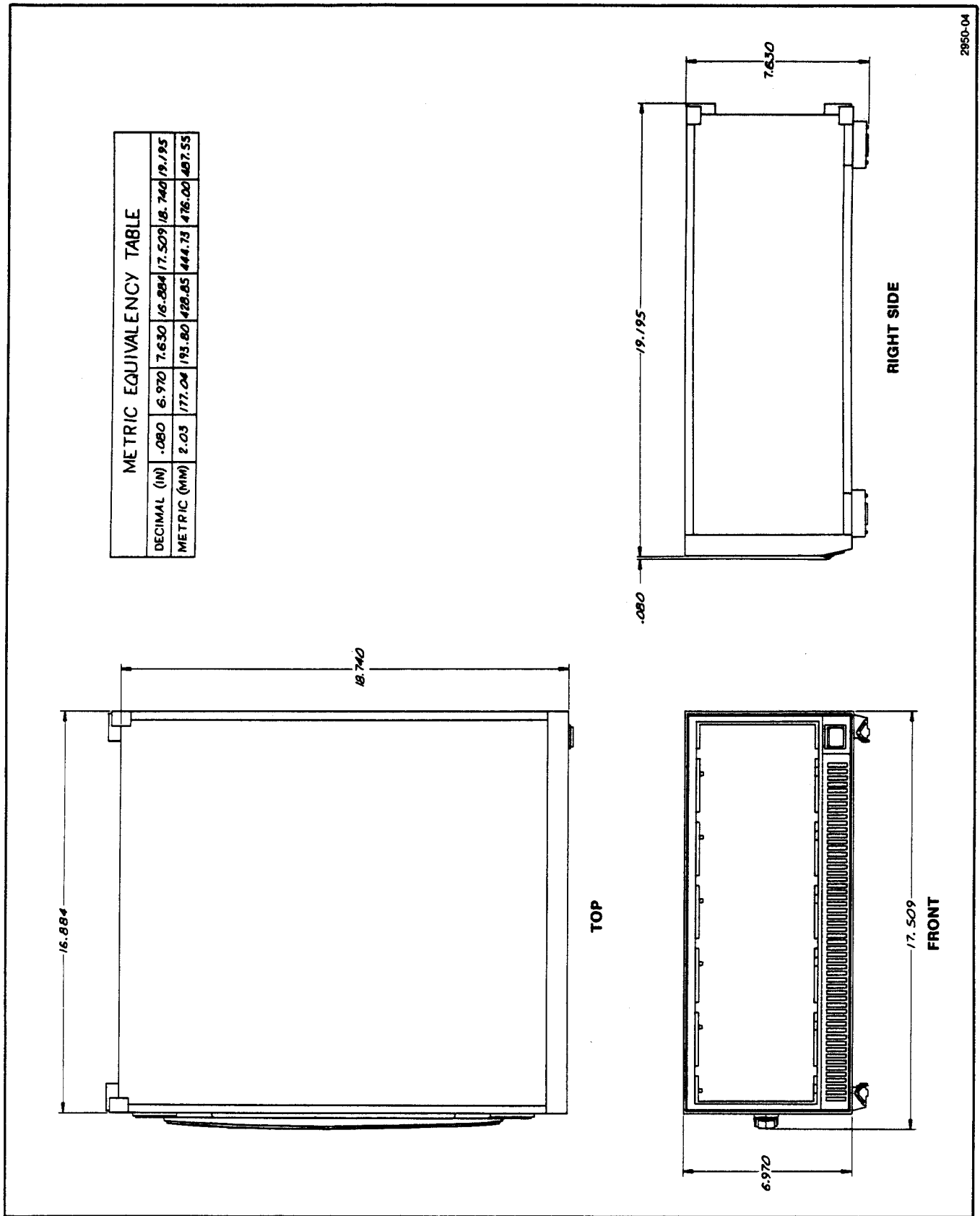

Fig. 2-3. TM 5006 bottom view.

2950-03

@



2850-04

Fig. 2-4. TM 5006, overall dimensions.

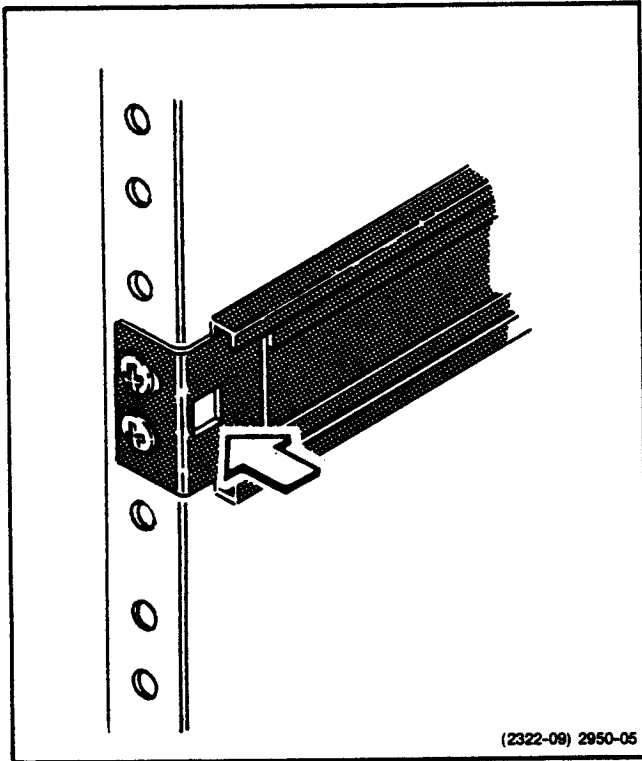

Fig. 2-5. Rack latch hole.

compartments to accept only members of that family, by installing a second barrier in the interface connector to match the module's slot location. An entire TM 5006 can be set up in this manner for specific work functions. For extra barriers, order Tektronix Part No. 214-1593-02.

Rear Panel

The rear panel has a connector mounting plate for bnc and multi-pin connector mountings. Customer or factory-installed connectors and wiring (Option 02) can provide external access to the interface. This feature makes the TM 5000-Series Modular Instrumentation System very flexible in bench-top or rackmounted systems.

Option 02

Qualified service personnel see Section 6 in the Service section of this manual for information on Option 02.

Repackaging Information

If the Tektronix instrument is shipped to a Tektronix Service Center for service or repair, attach a tag showing owner (with address) and the name of an individual at your firm to contact. Include the complete instrument serial number, option number and a description of the service required.

Save and reuse the package in which your instrument was shipped. If the original packaging is unfit for use or not available, repackage the instrument as follows:

Surround the instrument with polyethylene sheeting to protect the instrument finish. Obtain a carton of corrugated cardboard of the correct carton strength having inside dimensions of no less than six inches more than the instrument dimensions. Cushion the instrument by tightly packing three inches of dunnage or urethane foam between carton and instrument on all sides. Seal the carton with shipping tape or an industrial stapler.

The carton test strength for this instrument is 350 pounds per square inch.

WARNING

During rackmount installation, interchanging the left and right slide-out track assemblies defeats the extension stop (safety latch) feature of the tracks. Equipment could, when extended, come out of the slides and fall from the rack, possibly causing personal injury and equipment damage.

When mounting the supplied slide-out tracks, inspect both assemblies to find the LH (left hand) and RH (right hand) designations to determine correct placement. Install the LH assembly to your left side as you face the front of the rack and install the RH assembly to your right side. Refer to the rackmounting instructions in this manual for complete information.

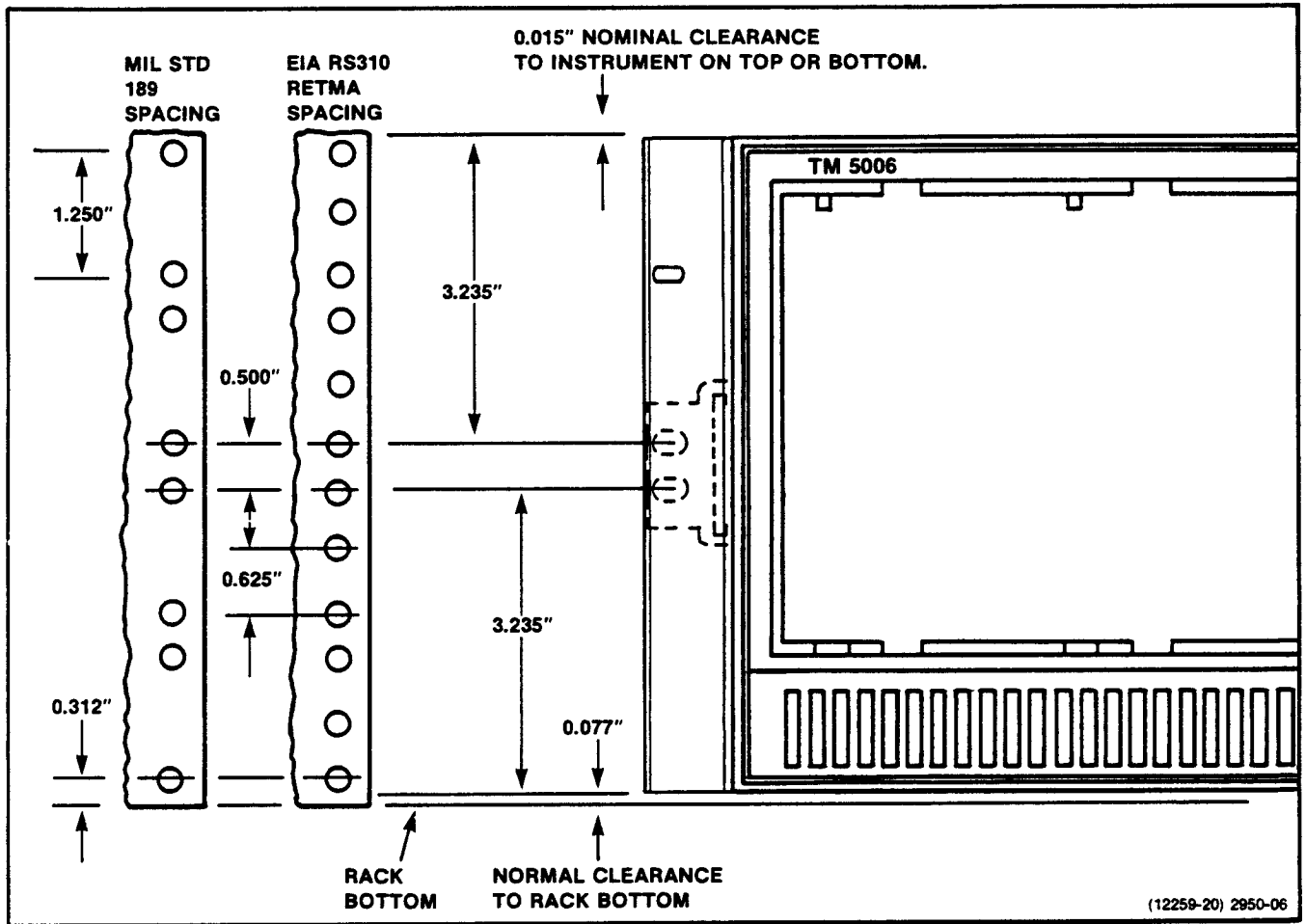

Fig. 2-6. Dimensions and positioning of TM 5006, Option 10, in standard rack.

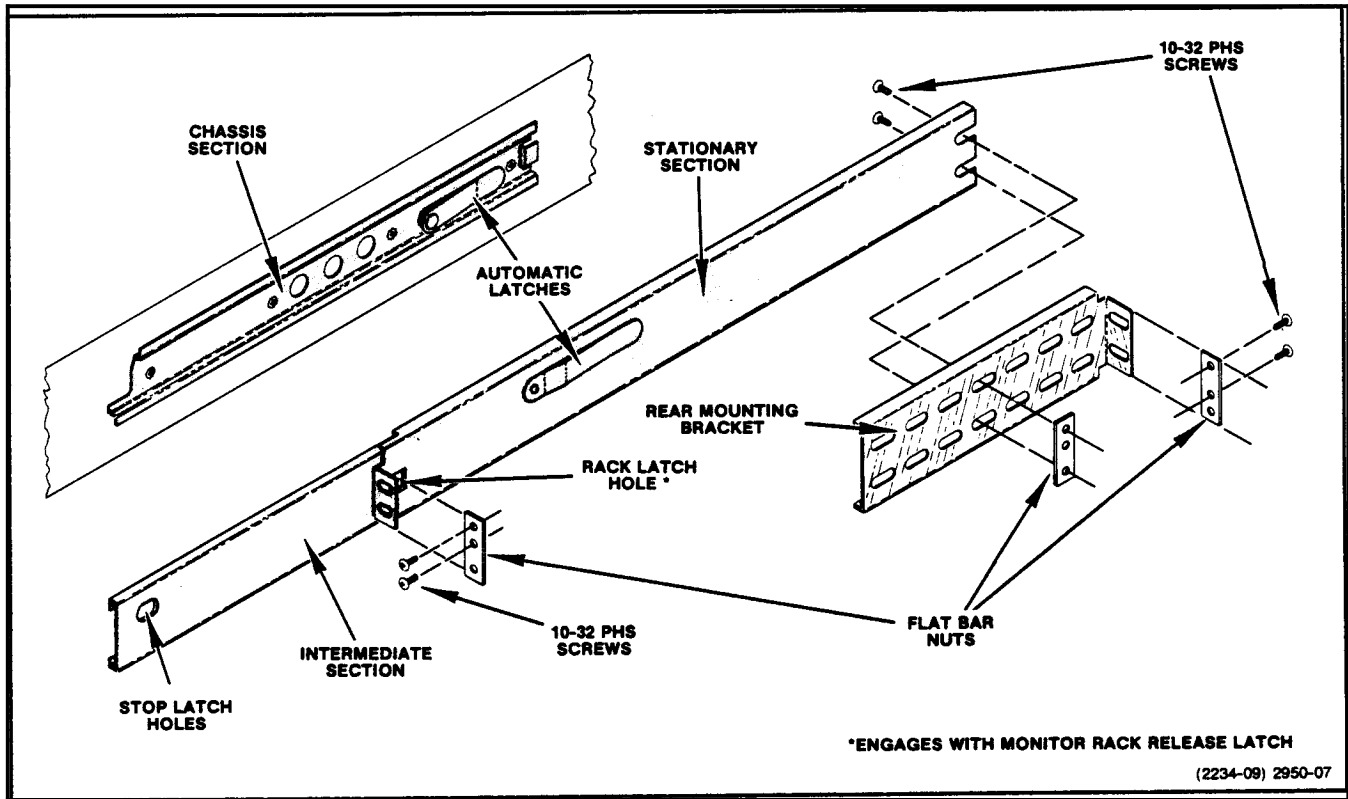

Fig. 2-7. Rackmount slide detail. If the rack has tapped holes, the bar nuts are not required.

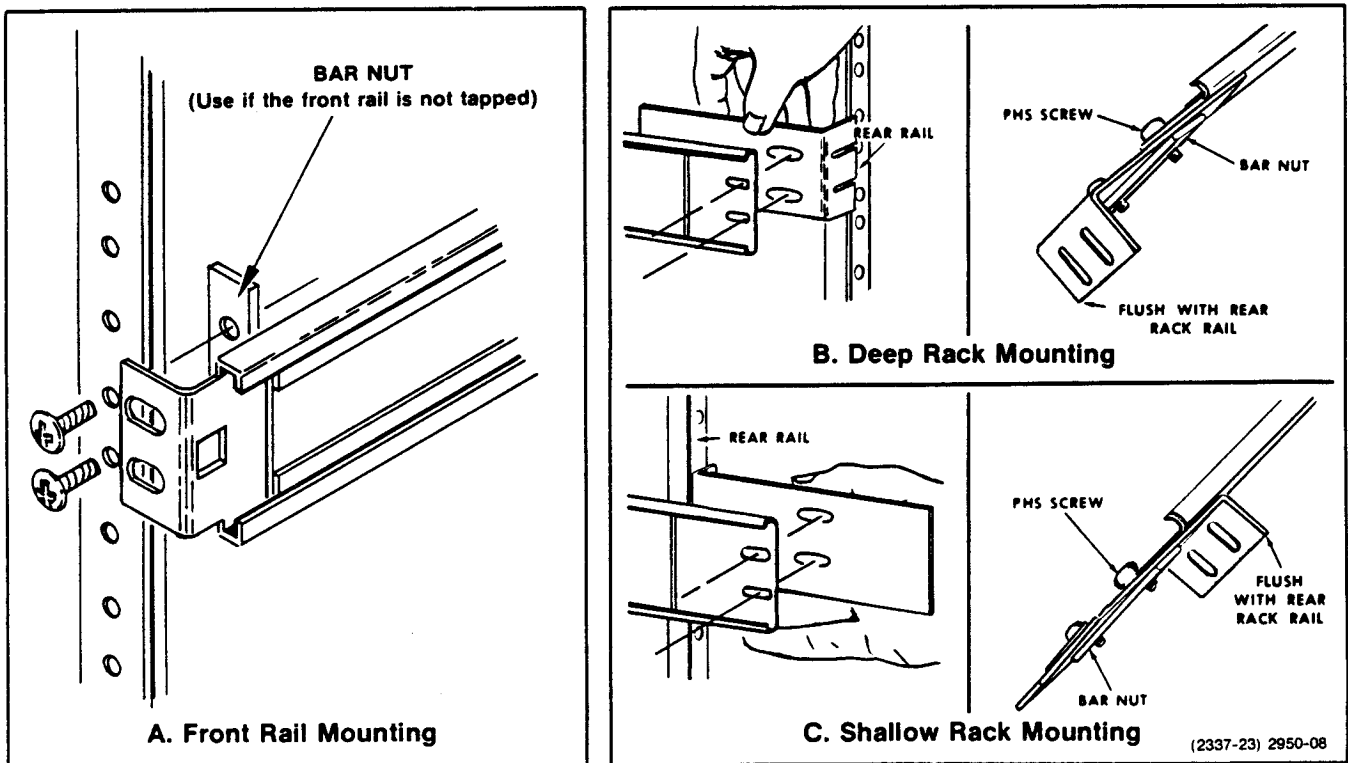

Fig. 2-8. Rackmounting slide details.

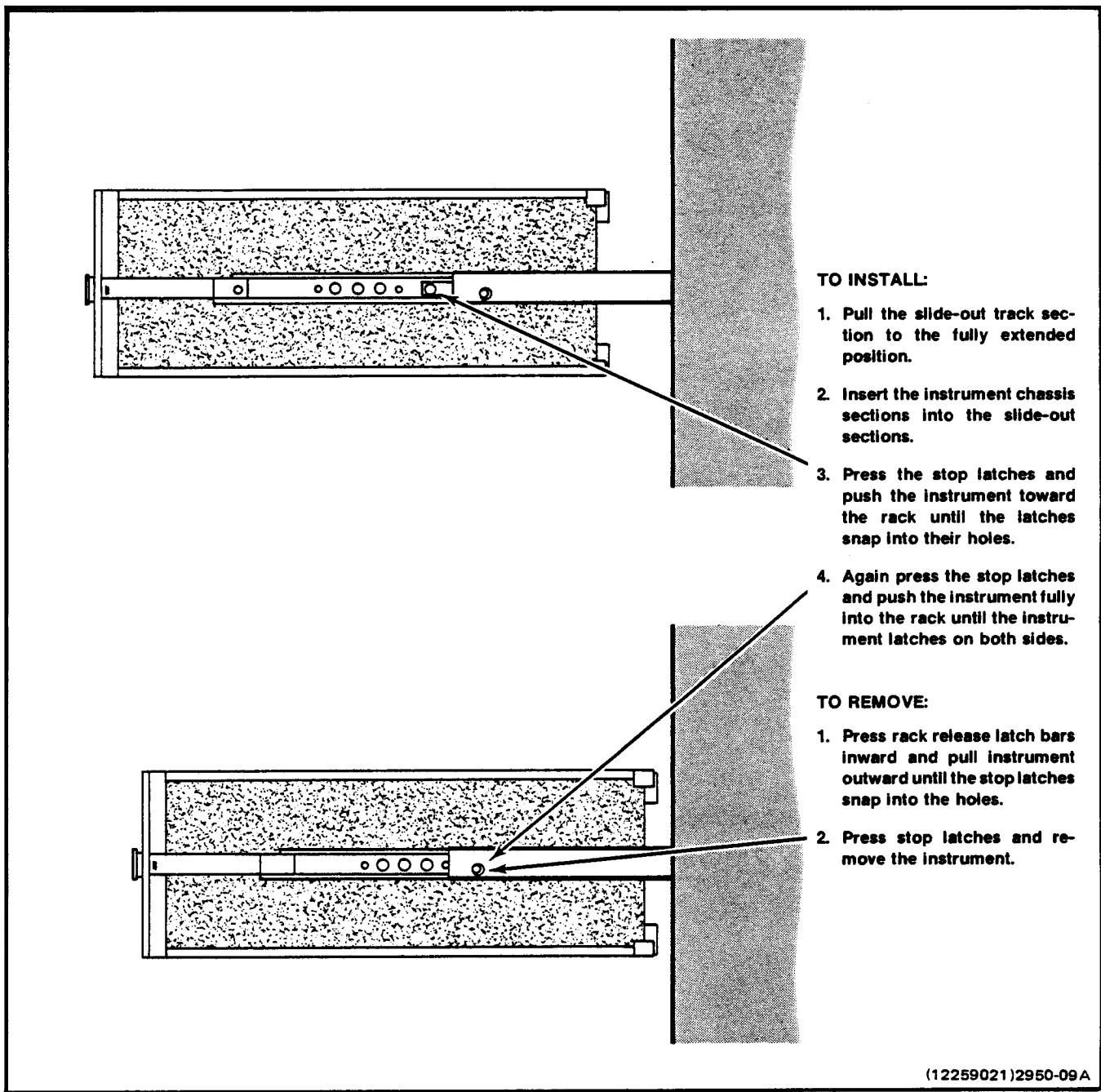
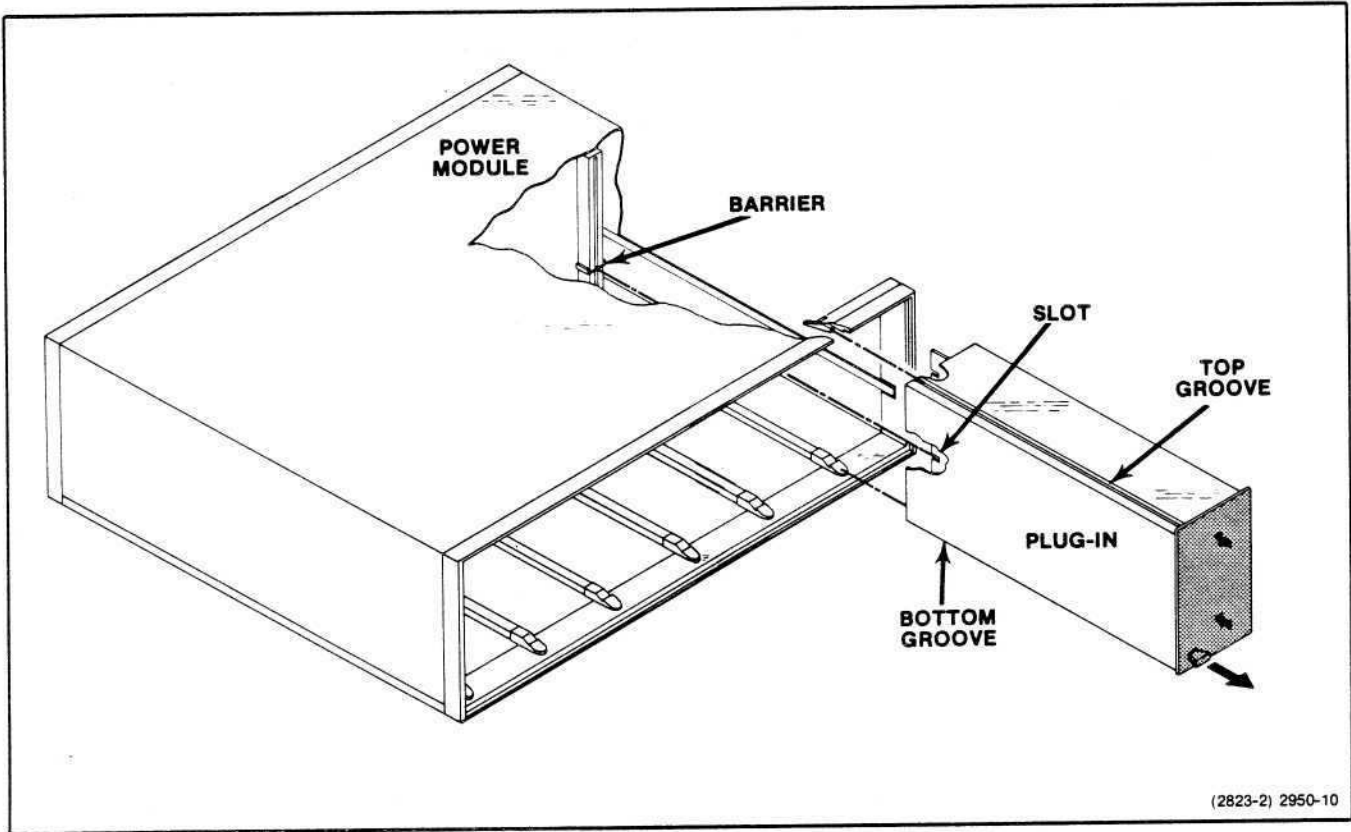
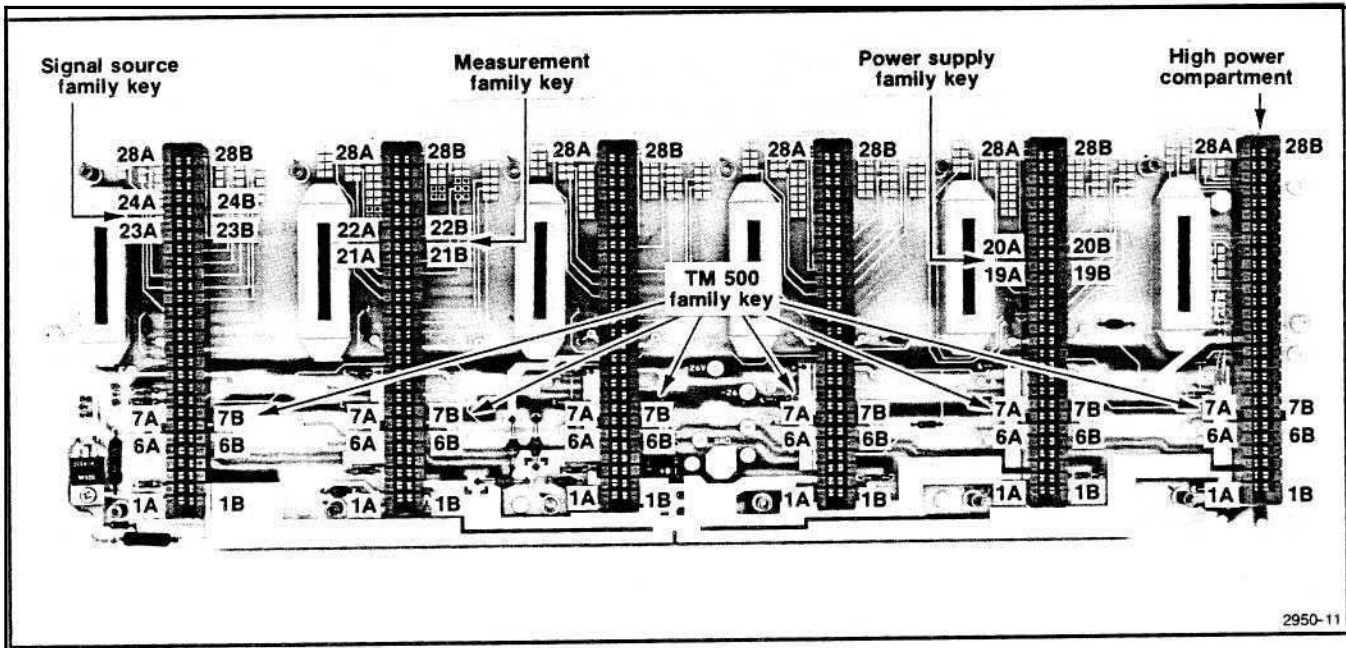

Fig. 2-9. Removing and installing TM 5006 in rack slides.



(2823-2) 2950-10

Fig. 2-10. Plug-in installation and removal.



2950-11

Fig. 2-11. Keying assignments for family functions. One of the many possible sequence combinations.

INSTRUCTIONS D'UTILISATION

Introduction

Le module d'alimentation TM 5006 est étalonné et prêt à l'emploi à la livraison. Une liste d'accessoires standard (avec numéros de référence) est fournie à la fin de ce manuel.

Source d'alimentation

AVERTISSEMENT

Source d'alimentation alternative et connexions. Cet instrument est conçu pour être utilisé à partir d'une source d'alimentation monophasée. Il possède un cordon d'alimentation à trois conducteurs, et une fiche à trois broches dont l'une est reliée à la masse. Le potentiel des deux pôles par rapport à la masse ne doit pas excéder la tension nominale maximale, 250 V.

Avant de brancher l'instrument, s'assurer que le sélecteur de tension est sur la position correspondant à la tension secteur, et que l'instrument possède une fiche bi-polaire à trois broches avec contact de masse. Sinon, s'adresser à un personnel de maintenance qualifié.

Liaison à la masse. Cet instrument est conforme aux normes de sécurité IEC classe 1. Toutes les parties conductrices accessibles de l'instrument sont reliées directement à la masse de la prise d'alimentation par l'intermédiaire du conducteur correspondant du cordon d'alimentation.

N'insérer la fiche que dans une prise comportant un contact à la masse. Ne pas supprimer ce contact. Toute interruption de la liaison à la masse entraînerait un risque d'électrocution.

Se reporter à la figure 2.1. Se référer aux indications relatives à la tension réseau et au fusible sur le panneau arrière.

Remplacement d'un fusible

Tourner vers la gauche et ôter le fusible. Le remplacer par un fusible du type approprié (voir indications sur panneau arrière).

Câblage

ATTENTION

Oter le cordon d'alimentation avant de procéder à l'installation du câble.

Pour plus de commodité, le câblage entre l'avant du module d'alimentation et son panneau arrière peut s'effectuer le long de la grille d'aération et dans le conduit de passage du câble, comme indiqué figure 2.2. Pour procéder au câblage, ôter le panneau d'accès à l'arrière du module d'alimentation. Se reporter à la figure 2.1. Puis ôter les deux vis de fixation et les fixations du panneau inférieur. Faire coulisser le panneau inférieur et l'ôter par l'arrière de l'instrument. Faire passer le câble par le conduit d'aération du panneau avant sous les rails de guidage du tiroir, et le faire sortir par le panneau d'accès. Remettre en place le panneau inférieur.

ATTENTION

Pour assurer une bonne ventilation, ne pas utiliser le module d'alimentation sans capot.

Utilisation sur une table de travail

Le module d'alimentation peut être utilisé en position inclinée. Procéder comme indiqué figure 2.3.

Montage en baie

Dimensions de la baie. Le TM 5006, option 10, est livré prêt à être monté en baie. Les principales dimensions de la baie sont indiquées figure 2.4. La figure 2.5 montre le découpage du système de verrouillage à ressort dans la partie fixe de la baie.

NOTE

Les rails à glissières latéraux fournis avec le TM 5006, option 10, présentent des trous dans leurs parties fixes pour l'insertion des verrous à ressort. Le TM 5006 option 10 ne doit pas être monté sur des rails à glissières non perforés.

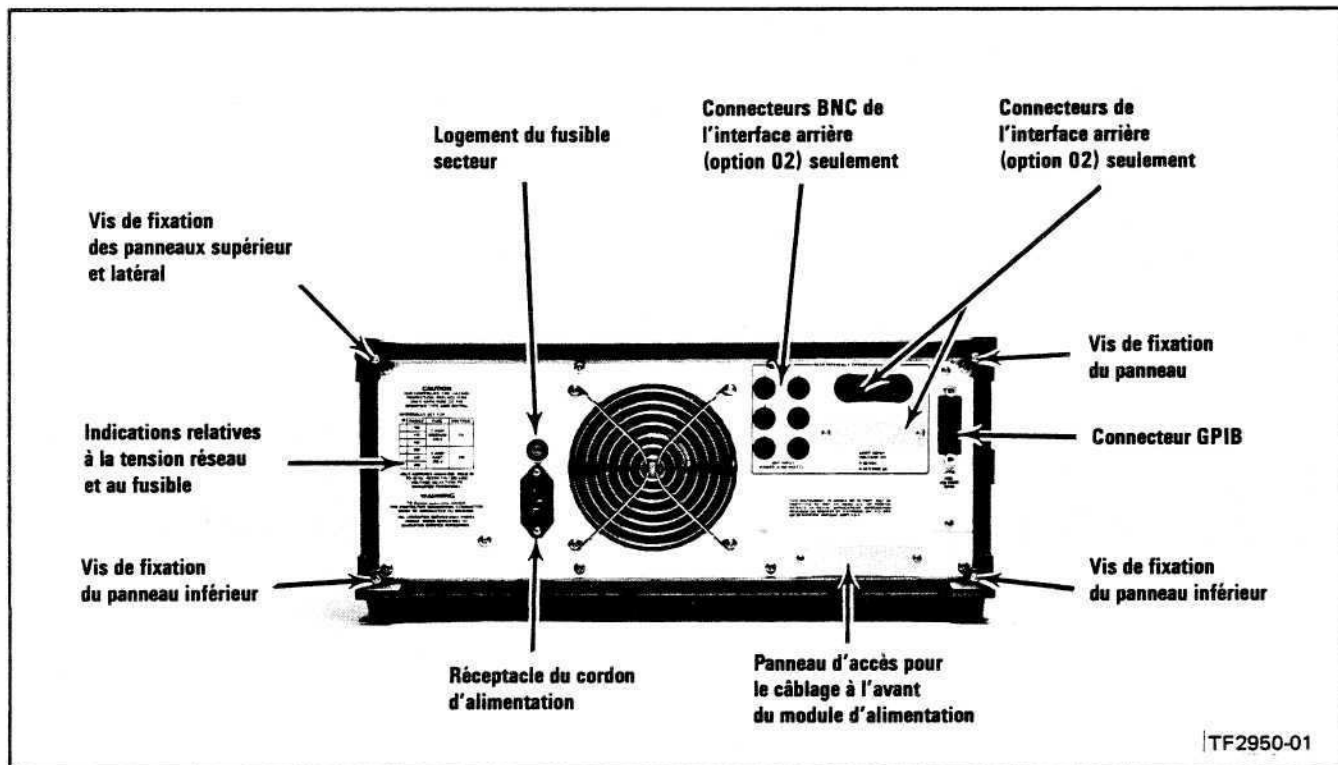

Fig. 2-1. Panneau arrière du TM 5006

Le TM 5006 option 10 s'adapte à des coffrets, baies, ou consoles standard de 19 pouces (48,26 cm). L'espacement des rails de montage frontaux ne peut être inférieur à 45,1 cm, afin de laisser un jeu suffisant pour le fonctionnement des glissières.

Les rails à glissières s'adaptent aisément sur les rails (verticaux) de montage avants et arrières d'une baie si la distance interne entre ces rails est comprise entre 26,6 et 62,2 cm.

Montage des rails à glissières. Repérer sur les glissières les trous permettant de les monter sur les rails de montage dans la baie (figure 2-6). Observer que l'espacement des trous sur les rails est variable. Lors de l'installation des rails à glissières dans des rails de montage de type EIA, veiller à ce qu'ils soient fixés dans les trous espacés de 1,2 cm. La figure 2-6 indique avec précision la position des rails à glissières dans la baie. Monter les rails en utilisant les pièces mécaniques indiquées figure 2-7 et 2-8. Les figures 2-8B et C contiennent les détails de montage dans des baies de diverses profondeurs. S'assurer que les parties fixes des rails à glissières sont alignées horizontalement de façon à ce qu'elles soient au même niveau et parallèles.

Installation du TM 5006 option 10 dans les rails à glissières. Vérifier que tous les tiroirs ont été ôtés du module d'alimentation. Tirer la partie intermédiaire des rails à glissières jusqu'à complète extension (v. fig. 2-9). Y insérer la partie fixée au châssis de l'instrument et pousser celle-ci jusqu'elle soit verrouillée dans la partie intermédiaire. Appuyer sur les deux boutons d'arrêt dans la partie intermédiaire en poussant l'instrument. Ce dernier peut maintenant être inséré dans la baie, le coffret ou la console. Les verrous fixant la partie intermédiaire à la partie fixe s'enclenchent automatiquement. Pousser à fond l'instrument dans la baie. Les verrous escamotables situés dans la partie fixe des rails s'engagent automatiquement dans les trous prévus pour le verrouillage dans la baie.

Retrait de l'instrument. Oter tous les tiroirs du module d'alimentation. Dévisser les deux grosses vis situées dans la partie supérieure du panneau avant. Tirer les verrous rectangulaires des deux côtés du panneau avant, en tirant à vous l'instrument jusqu'à ce que la partie intermédiaire des rails à glissières soit arrêtée par la partie fixée au châssis et par les parties fixes des rails. Maintenir fermement l'instrument dans cette position. Pour l'ôter complètement, appuyer sur les deux boutons d'arrêt dans la partie intermédiaire des rails à glissières et faire glisser avec précaution l'appareil hors de la baie ou du coffret.

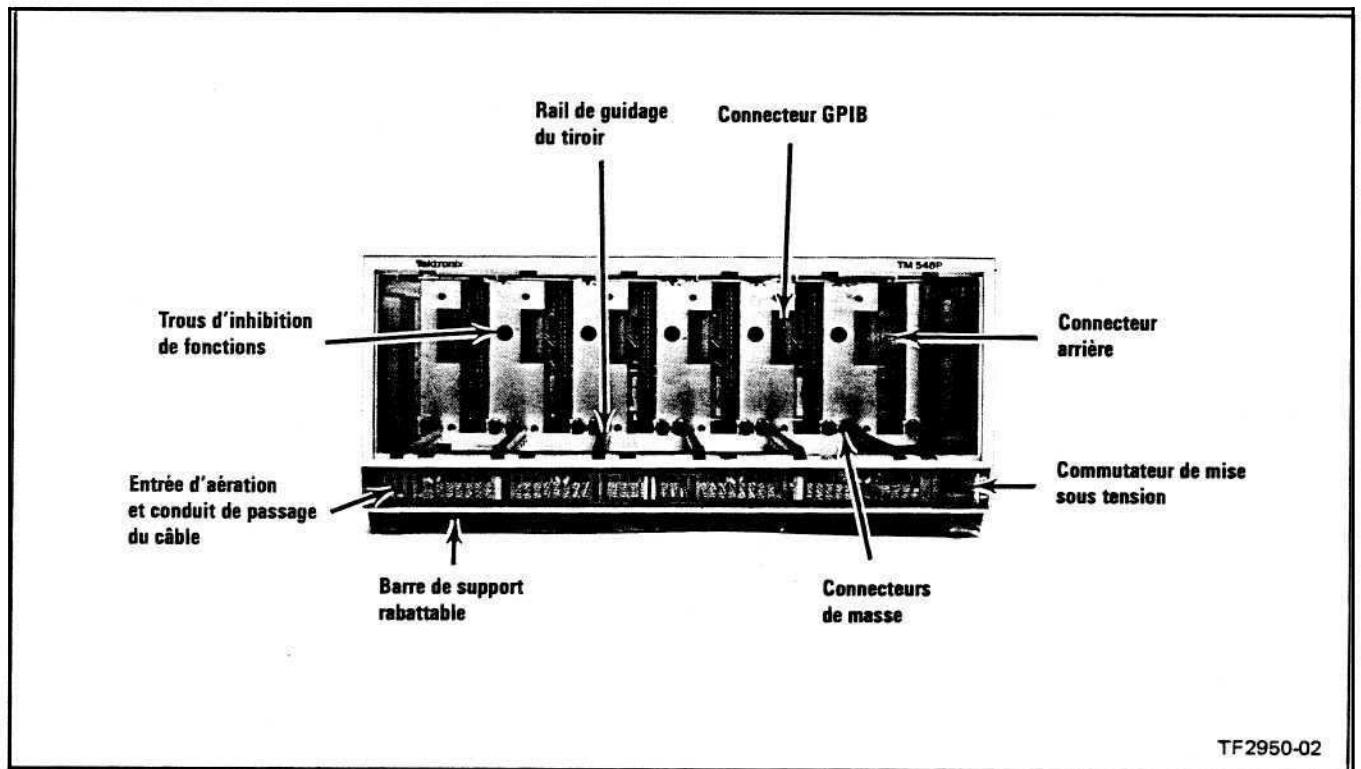

Fig. 2-2. Vue de face du TM 5006

Réglages dans la baie. Après l'installation de l'appareil dans la baie, il se peut que les glissières coulissent mal si elles n'ont pas été ajustées correctement. Faire glisser l'instrument hors de la baie jusqu'à obtenir un intervalle de 25,4 cm entre son panneau avant et l'avant de la baie. Desserrer légèrement les vis maintenant les rails latéraux aux rails de montage frontaux. Resserrer les vis et vérifier le bon fonctionnement des glissières en faisant coulisser l'instrument à l'intérieur et à l'extérieur de la baie.

Maintenance des rails à glissières. Les rails à glissières ne nécessitent pas de lubrification, le revêtement gris sombre sur les glissières étant auto-lubrifiant.

Installation et retrait des tiroirs

ATTENTION

Eteindre le module d'alimentation avant d'insérer ou d'ôter un tiroir pour éviter que les circuits du tiroir ne soit endommagés.

NOTE

Les tiroirs DC 505, DC 505A, et LA 501W ne sont pas compatibles avec ce module d'alimentation.

Assurez-vous que les détrompeurs du connecteur du compartiment coïncident avec les encoches correspondantes du tiroir utilisé. Le compartiment de droite est le compartiment haute puissance. Aligner les rainures supérieures et inférieures du tiroir avec les guides du compartiment sélectionné (fig. 2.10). Insérer le tiroir et le pousser à fond pour que le circuit imprimé se place correctement. Mettre le module en service.

Compatibilité avec les autres familles

Mécaniquement, les TM 500 et TM 5000 ressemblent à beaucoup d'autres familles de produits Tektronix. Électriquement cependant, elles ne sont pas compatibles. C'est pourquoi, afin de prévenir toute erreur possible, le connecteur du module d'alimentation est équipé d'un détrompeur entre les contacts 6 et 7. Un tiroir compatible devra donc posséder une encoche correspondante à cette position.

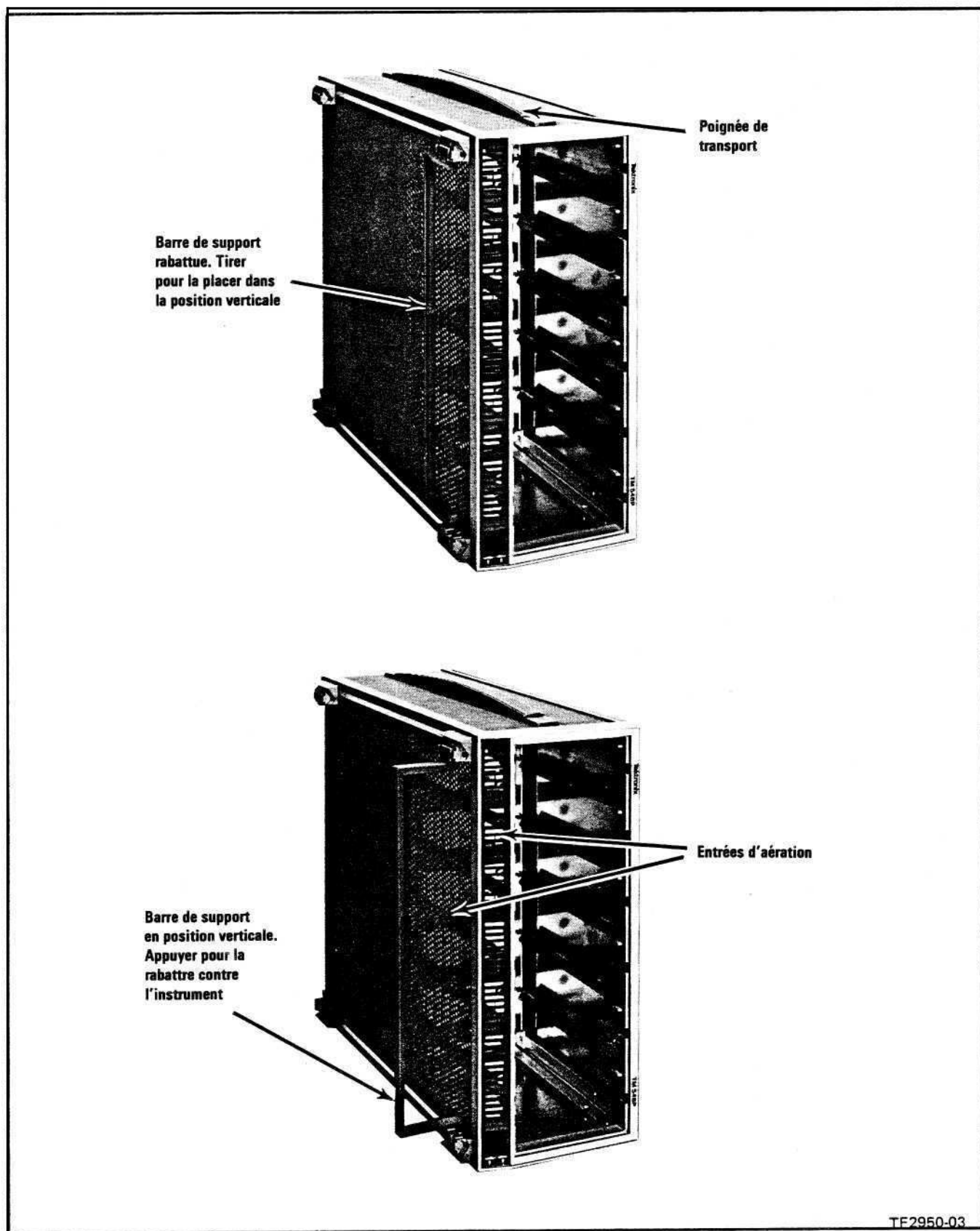

Fig. 2.3. Vue de dessous du TM 5006

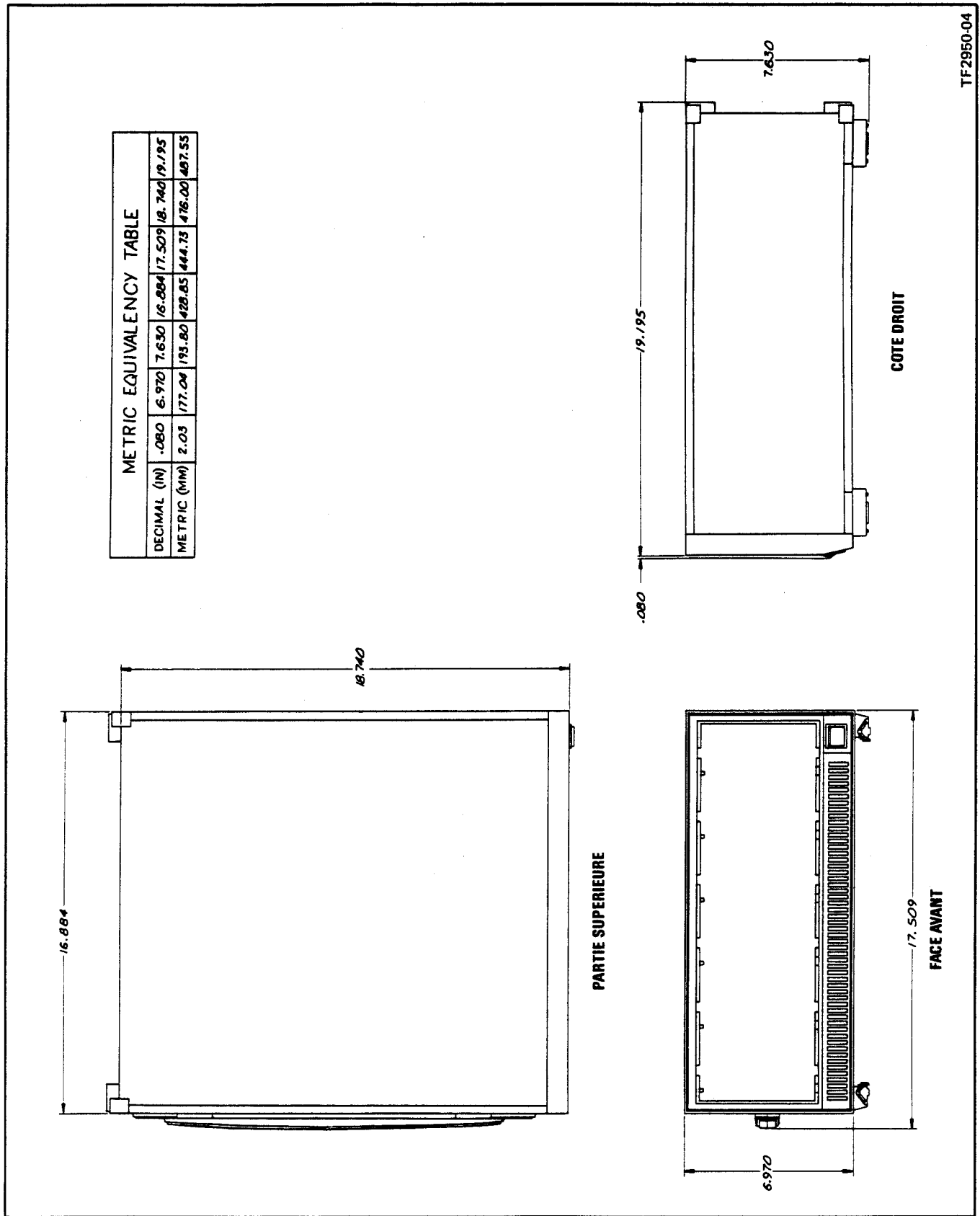

Fig. 2.4. Dimensions hors-tout du TM 5006, option 10

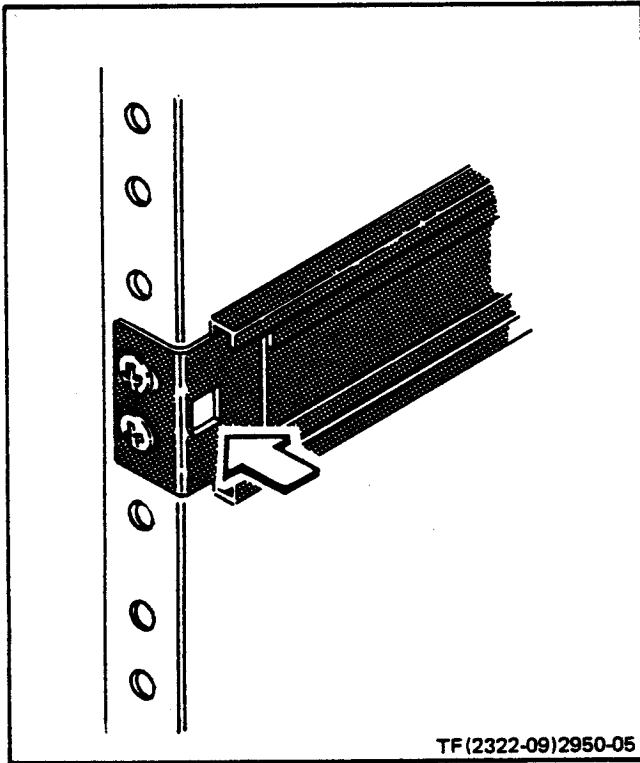

Fig. 2.5. Trou de verrouillage dans la baie

Personnalisation de l'interface

La conception modulaire de ce système d'instrumentation offre une multiplicité de fonctions réalisables. Les fonctions spécifiques sont groupées par familles ou par classes, dans lesquelles il est possible de trouver plusieurs tiroirs : familles des Alimentations, Générateurs de Signaux, de Mesure, etc... Chacun des membres d'une famille fonctionnelle possède, au niveau du connecteur, une seconde encoche spécifique à cette famille. L'utilisateur a donc la faculté de personnaliser un compartiment ou plus de son module d'alimentation TM 5006, de façon à ce qu'il(s) n'accepte(nt) que les membres d'une seule famille. Pour cela, il suffit d'installer un second détrompeur sur le connecteur en regard de la seconde encoche. Tout un module

d'alimentation TM 5006 peut ainsi être réservé à des fonctions spécifiques. Des détrompeurs supplémentaires peuvent être obtenus sous la référence 214-1593-02.

Panneau arrière

Sur le panneau arrière des emplacements sont prévus pour des prises BNC et un connecteur multibroches. Les prises, installées soit en usine (v. option 02), soit par l'utilisateur lui-même donnent un accès à l'interface. Cette caractéristique garantit une grande souplesse d'utilisation.

Option 02

Des informations sur cette option, destinées à un personnel de maintenance, figurent au chapitre Maintenance de ce manuel.

Instructions de réemballage

Si cet instrument doit être renvoyé à un service de maintenance Tektronix pour une révision ou un travail de maintenance, y apposer une étiquette portant le nom (et l'adresse) de la société utilisatrice et le nom de la personne à contacter, ainsi que le numéro de série de l'instrument, et la description du défaut constaté.

Utiliser de préférence l'emballage d'origine de l'instrument. Si celui-ci n'est plus disponible, emballer l'appareil de la façon suivante :

Entourer l'instrument d'une feuille de polyéthylène. Se procurer un carton résistant dont les dimensions internes soient supérieures de 15 cm aux dimensions de l'appareil. Tapiser le fond et les bords du carton de mousse d'urethane sur une épaisseur de 15 cm. Fermer le carton au moyen d'une bande adhésive.

La résistance de l'emballage est de 62 Kg/cm².

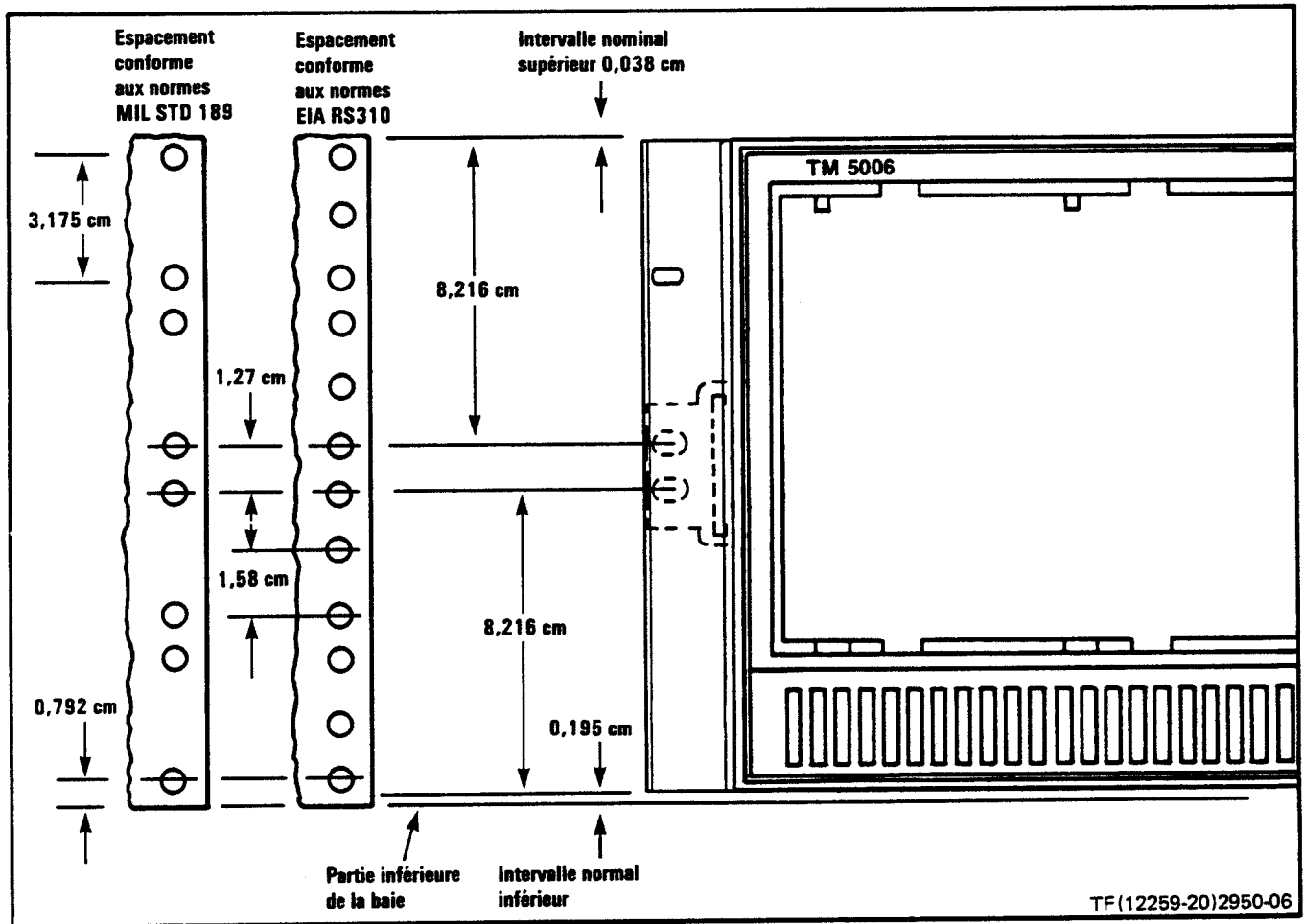

Fig. 2.6 Dimensions et positionnement du TM5006, option 10 dans une baie standard

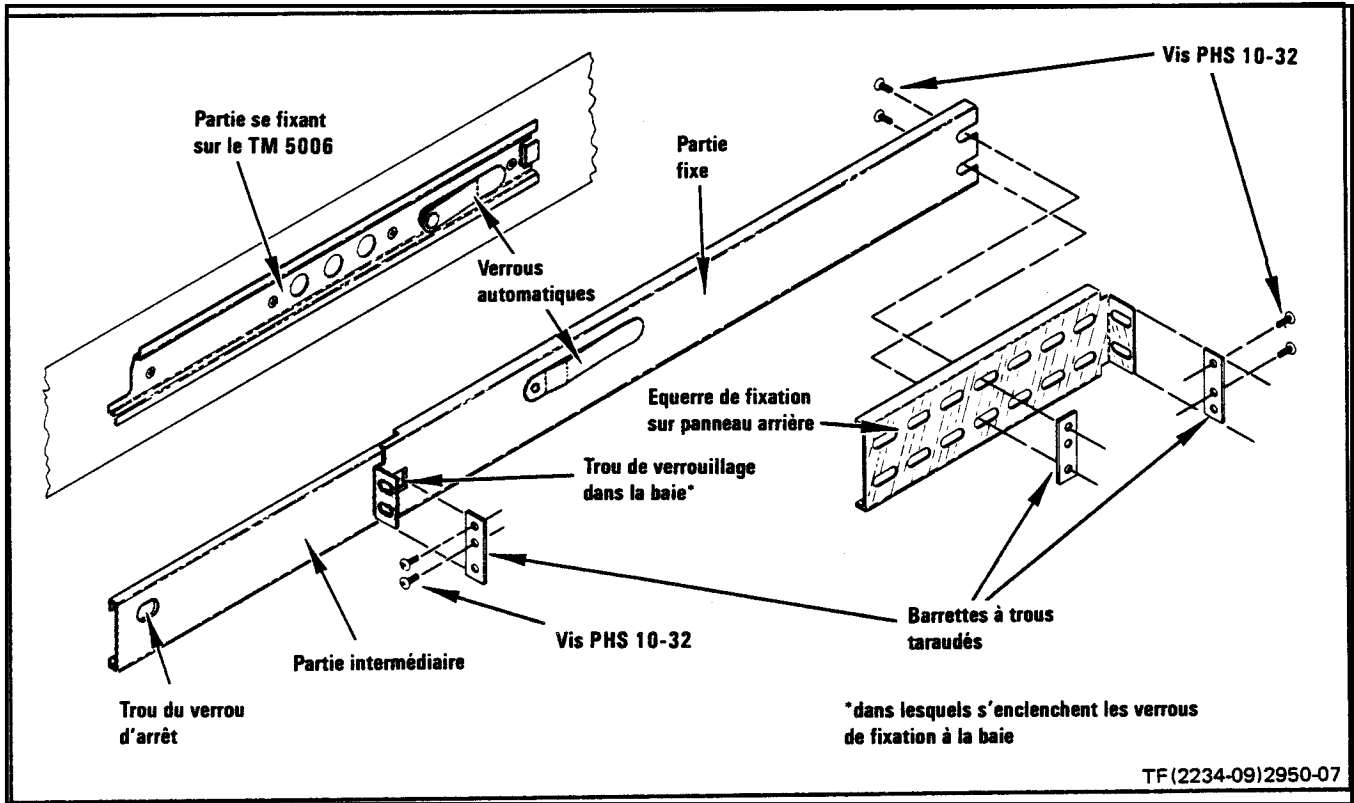

Fig. 2.7 Fixation des rails à glissières sur la baie. Si la baie a des trous taraudés, les barrettes taraudées ne sont pas nécessaires.

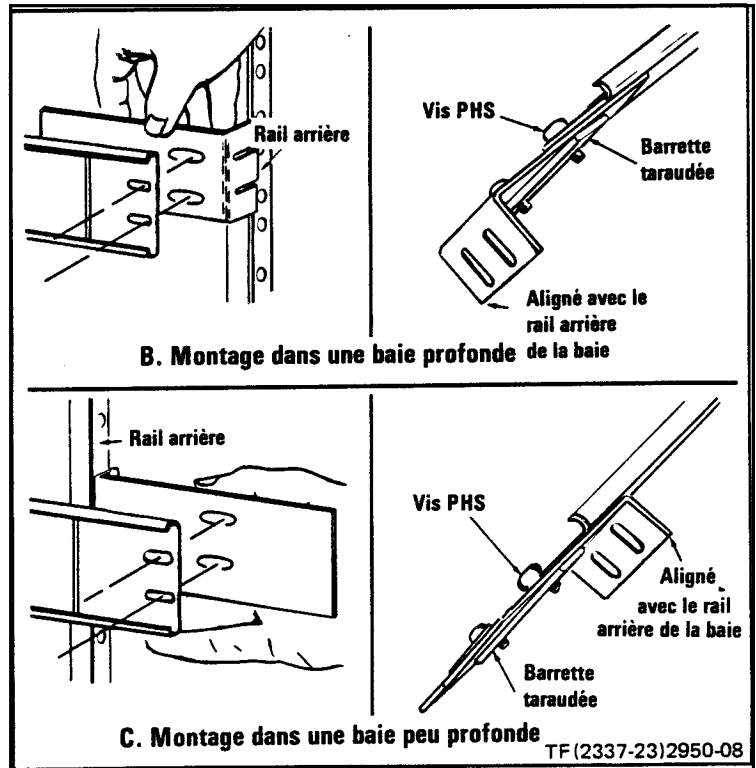
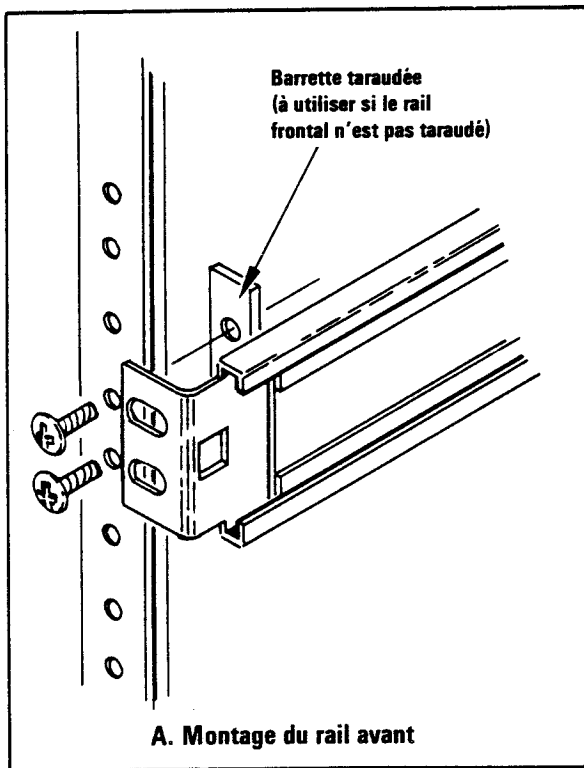
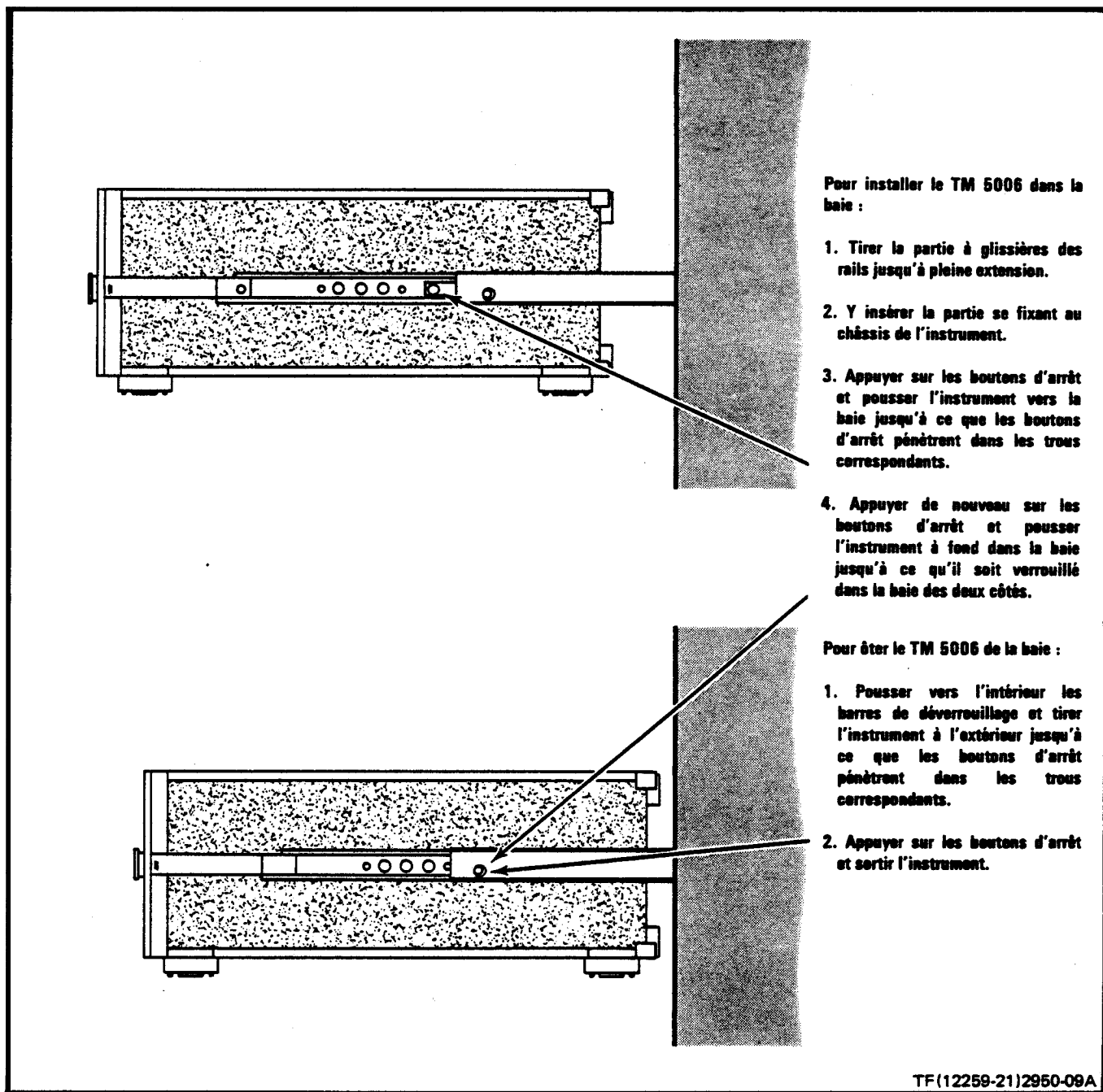

Fig. 2-8. Montage des rails à glissières sur la baie



TF(12259-21)2950-09A

Fig. 2-9 Retrait et installation du TM 5006, option 10 dans les rails à glissières

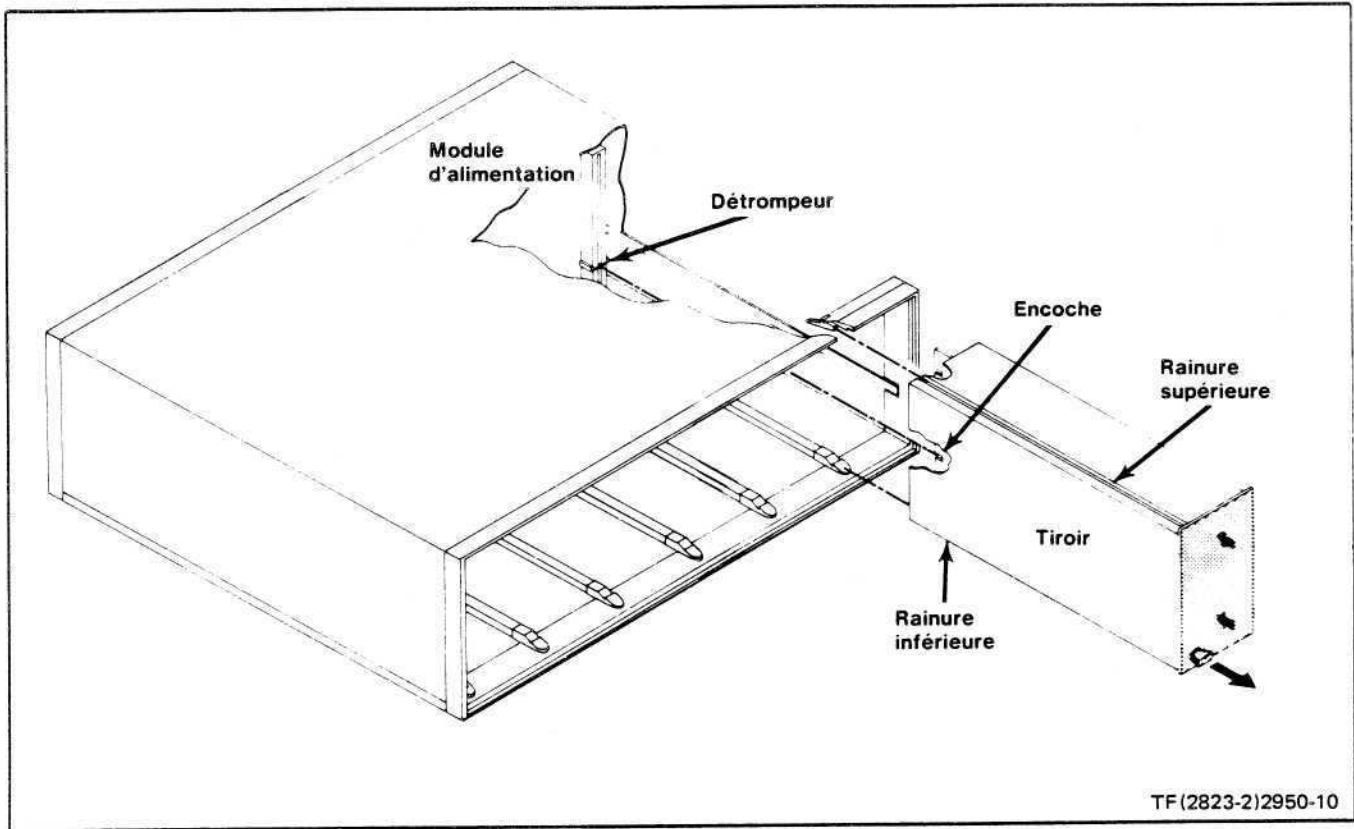

Fig. 2.10 Installation et retrait d'un tiroir

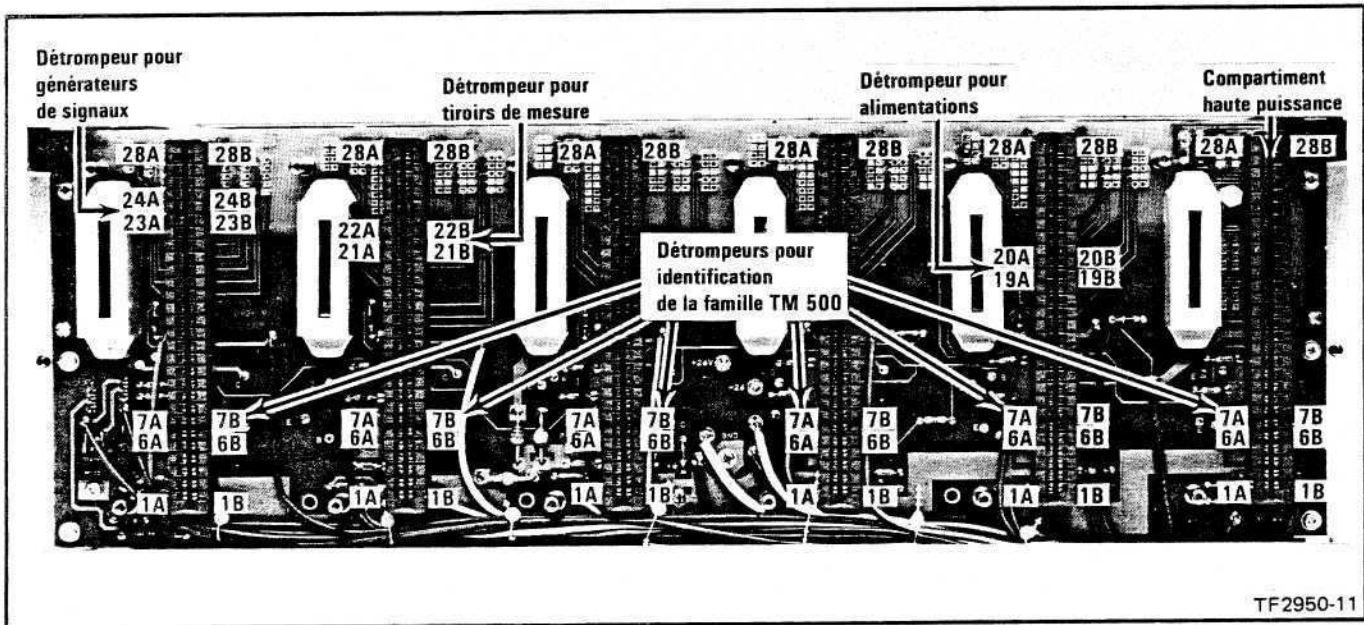

Fig. 2.11. Familles de fonctions. Une des nombreuses combinaisons possibles.

BEDIENUNGSANLEITUNG

Einführung

Die Versorgungseinheit TM 5006 wird kalibriert und betriebsbereit geliefert. Eine Liste des serienmäßigen Zubehörs (und der Teile-Nrn.) befindet sich im hinteren Teil dieses Handbuches.

Netzspannungsversorgung

WARNUNG

ANSCHLUSS AN DAS WECHSELSTROMNETZ. Dieses Gerät ist für den Betrieb von einer einphasigen Spannungsquelle ausgelegt. Es hat ein 3adriges Netzkabel und einen zweipoligen Stecker mit Schutzkontakt. Die Spannung zwischen den Netzpolen und Erde darf die maximale Betriebsspannung von 250 V nicht übersteigen.

Stellen Sie vor Anschluß der Versorgungseinheit fest, ob das Gerät auf die richtige Netzspannung eingestellt ist und ob das Gerät mit einem passenden Netzstecker mit Schutzkontakt ausgerüstet ist. Überlassen Sie Änderungen dem qualifizierten Servicepersonal.

ERDUNG. Dieses Gerät entspricht der Schutzklasse I (nach IEC-Norm). Alle zugänglichen, leitenden Teile sind über den Schutzleiter des Netzkabels direkt mit dem Schutzkontakt des Netzsteckers verbunden.

Der Netzstecker darf nur in eine passende Netzsteckdose mit Schutzkontakt eingesteckt werden. Jede Unterbrechung der Erdungsschutzleitung kann einen elektrischen Schlag verursachen.

Um elektrische Schläge zu vermeiden, muß vor Anschluß der Ein- und Ausgänge des Gerätes die Erdschutzverbindung hergestellt werden.

Siehe Bild 2-1. Angaben über Netzspannungen und Sicherungen befinden sich auf der Rückwand des Gerätes.

Auswechseln der Sicherung

Drehen Sie die Kappe des Sicherungshalters nach links und nehmen Sie die Sicherung heraus. Setzen Sie eine neue Sicherung des richtigen Typs, wie auf der Rückwand angegeben, ein.

Verkabelung

VORSICHT

Vor der Verlegung von Kabeln ist das Netzkabel zu entfernen.

Kabel können von der Vorderseite der Versorgungseinheit, wie in Bild 2-2 gezeigt, durch die Lüftungsschlitze und den Kabelkanal zur Rückseite geführt werden. Dazu ist zuerst die Abdeckplatte an der Rückseite des Gerätes zu entfernen. Siehe Bild 2-1. Als Nächstes entfernen Sie die Befestigungsschrauben der Bodenplatte und die Halter der Bodenplatte. Dann ziehen Sie die Bodenplatte nach hinten aus dem Gerät heraus. Führen Sie die Kabel durch die Lüftungsschlitze an der Vorderseite, an den Einschub-Führungsschienen entlang und durch die Öffnung der Abdeckplatte. Danach wird die Bodenplatte wieder angebracht.

VORSICHT

Um ausreichende Kühlung zu gewährleisten, dürfen während des Betriebs keine Gehäuseteile entfernt sein.

Tischbetrieb

Die Versorgungseinheit kann mit hochgestellter Vorderseite betrieben werden. Zum Hochstellen der Vorderseite ist der Aufstellbügel, wie in Bild 2-3 gezeigt, herauszuklappen.

Anleitungen für den Gestelleinbau

Gestellabmessungen. Das Gerät TM 5006, Option 10 wird ab Werk einbaufertig für den Gestelleinbau geliefert. Bild 2-4 zeigt die Haupt-Abmessungen. Bild 2-5 zeigt die Aussparungen für die Haltefedern im feststehenden Teil der Gleitschiene.

ANMERKUNG

Die mit der TM 5006, Option 10 gelieferten Gleitschienen, haben in ihrem feststehenden Teil Löcher für die Aufnahme der Haltefedern. Die TM 5006, Option 10 sollte nicht mit Gleitschienen eingebaut werden, bei denen diese Löcher fehlen.

Die TM 5006, Option 10 paßt in Standard 19-Zoll-Gehäuse, Gestelle und Konsolen. Der Zwischenraum zwischen den vorderen Eckschienen, muß mindestens 17 3/4 Zoll betragen. Nur dann ist ein einwandfreies Gleiten des Gerätes auf den Gleitschienen gewährleistet.



Bild 2-1. TM 5006 Rückwand.

Die Gleitschienen können in jedes Gestell, das zwischen den vorderen und den hinteren Eckschienen einen Zwischenraum von 10 ½ bis 24 ½ Zoll hat, eingebaut werden.

Einbau der Gleitschienen. Suchen Sie, wie in Bild 2-6 gezeigt, im Gestell die passenden Löcher für den Einbau. Beachten Sie, daß der Lochabstand in den Gestellen verschieden ist. Achten Sie beim Einbau der Gleitschienen in Gestelle des Typs EIA darauf, daß die Gleitschienen an den Löchern mit ½ Zoll Abstand angebracht werden. Bild 2-6 zeigt auch, wie die Position der Gleitschienen im Gestell bestimmt wird. Montieren Sie die Gleitschienen unter Verwendung des mitgelieferten Zubehörs, wie es in den Bildern 2-7 und 2-8 gezeigt wird. Die Bilder 2-8B und C zeigen Einbaudetails für tiefe und flache Gestelle. Achten Sie darauf, daß die feststehenden Teile der Gleitschienen horizontal ausgerichtet sind, sodaß sie in gleicher Höhe und parallel zueinander liegen.

Einsetzen der TM 5006, Option 10 in die Gleitschienen. Stellen Sie sicher, daß sich kein Einschub in der Versorgungseinheit befindet. Ziehen Sie die Schiebeteile der Gleitschienen soweit wie möglich heraus. Siehe Bild 2-9. Setzen Sie die Führungsschienen am

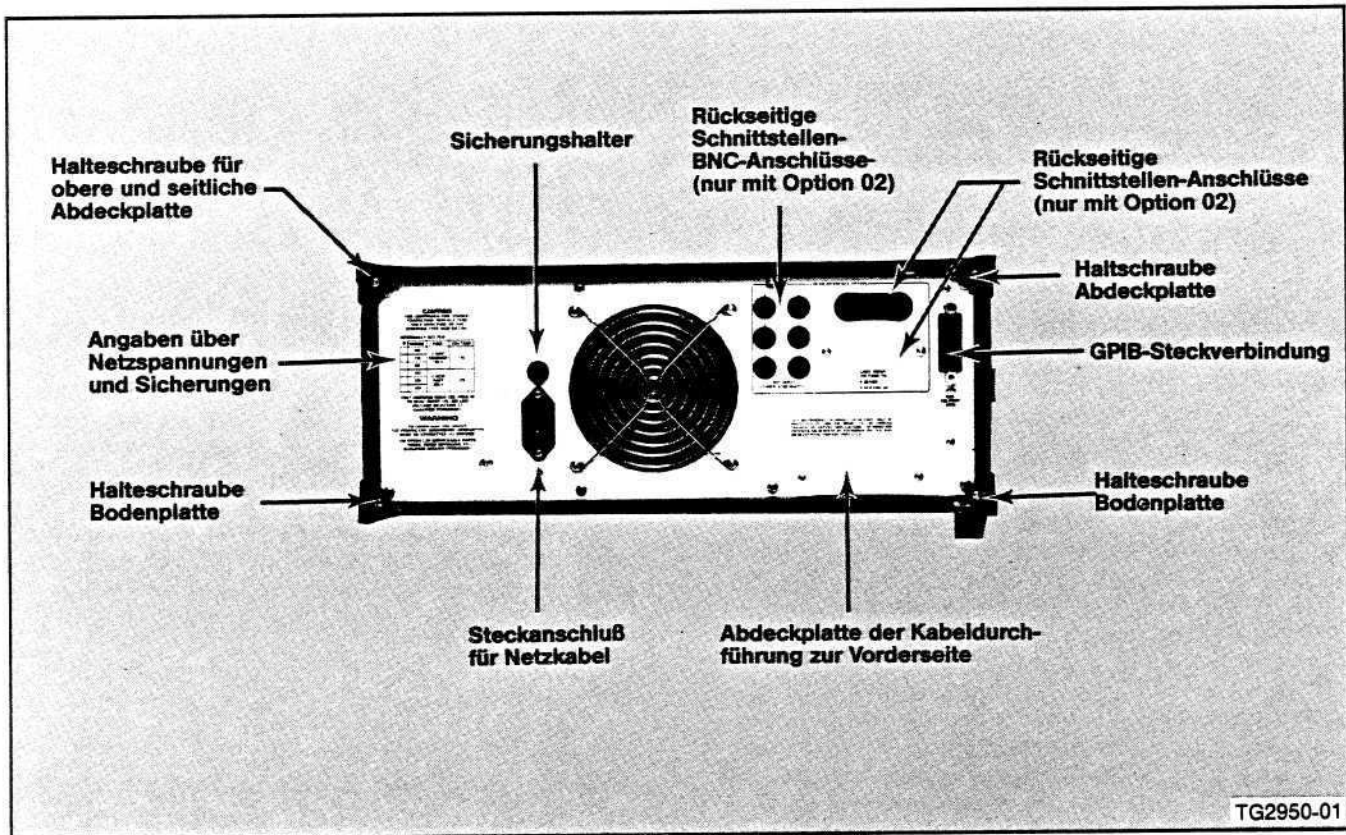
Gerätechassis an die Schiebeteile und drücken Sie das Gerät vorwärts, bis die Führungsschienen in die Schiebeteile einrasten. Jetzt drücken Sie die beiden aus den Haltefederlöchern der Schiebeteile herausragenden Knöpfe, während Sie das Gerät weiter eindringen. Das Gerät kann jetzt in das Gestell, Gehäuse oder die Konsole eingeschoben werden. Die Haltefedern, die die Schiebe-Zwischenstücke in den feststehenden Teilen der Gleitschienen halten, rasten automatisch ein, wenn das Gerät in das Gestell oder Gehäuse eingeschoben wird. Die Verriegelungsklinken am Gerät rasten automatisch in die Aussparungen in den feststehenden Teilen der Gleitschienen ein, wenn das Gerät ganz in das Gestell eingeschoben wird.

Ausbau des Gerätes. Nehmen Sie alle Einschübe aus der Versorgungseinheit heraus. Lösen Sie die beiden Rändelschrauben an der Oberseite der Frontplatte. Ziehen Sie die beiden rechteckigen Hebel an beiden Seiten der Frontplatte. Mit diesen Hebeln ziehen Sie das Gerät heraus, bis die Schiebeteile der Gleitschienen an den Führungsschienen des Gerätes und den feststehenden Teilen der Gleitschienen einrasten. Das Gerät wird in dieser Stellung sicher gehalten. Um das Gerät ganz herauszunehmen drücken Sie jetzt die beiden Knöpfe der Haltefedern, die in den Löchern der Schiebeteile sichtbar werden und ziehen das Gerät vorsichtig aus dem Gestell oder Gehäuse heraus.



Bild 2-2. TM 5006 Vorderansicht.

Wartung der Gleitschienen. Die Gleitschienen bedürfen keiner Schmierung. Bei dem dunkelgrauen Belag auf den Gleitflächen handelt es sich um eine Dauer-Schmierschicht.

Ein- und Ausbau von Einschüben

VORSICHT

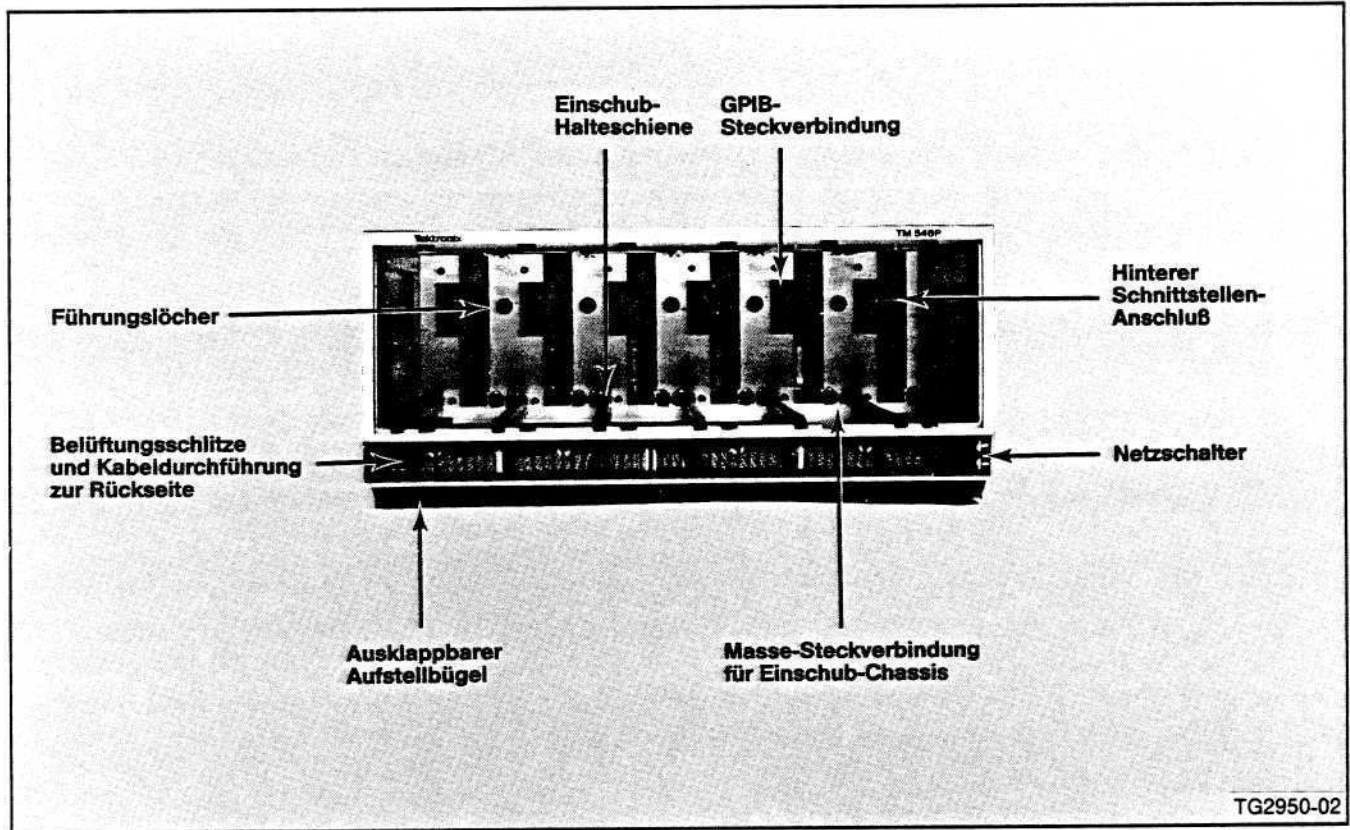
Um eine Beschädigung der Einschub-Schaltkreise zu vermeiden, ist die Versorgungseinheit vor Ein- oder Ausbau des Einschubes abzuschalten.

ANMERKUNG

Die Einschübe DC 505, DC 505A und LA 501W sind mit dieser Versorgungseinheit nicht kompatibel.

Prüfen Sie ob die Kunststoffsperrn an der Steckerbuchse des gewählten Einschubfaches mit den Aussparungen an der Steckerleiste des Einschubes übereinstimmen. Das äußerste rechte Fach, ist das Hochleistungs-Einschubfach. Setzen Sie das Einschub-Chassis an die obere und untere Führungsschiene des gewählten Einschubfaches an (siehe Bild 2-10) und drücken Sie den

Einschub mit festem Druck ein, bis die Steckverbindung einrastet. Schalten Sie die Versorgungseinheit ein.

Kompatibilität

Mechanisch sind die TM 500 Einschub-Moduln anderen Tektronix Gerätefamilien sehr ähnlich. Elektrisch sind sie jedoch nicht kompatibel. Darum hat die Schnittstelle an der Steckerbuchse zwischen den Kontakten 6 und 7 Sperren, die das Einsetzen von inkompatiblen Einschüben verhindern. Siehe Bild 2-11. Ein kompatibles Modul hat zwischen den Kontakten 6 und 7 seiner Steckerleiste eine entsprechende Aussparung. Diese Kombination von Sperre und Aussparung ist die Haupt-Anpassungsvorrichtung.

Anpassung der Schnittstelle

Die Modularisierung dieses Gerätesystems ermöglicht die Ausübung vieler verschiedener Funktionen durch die Einschub-Moduln. Spezielle Funktionen sind zu Familien oder Klassen zusammengefaßt, für die es mehrere Einschub-Moduln als Mitglieder geben kann. So bestehen z. B. einige Klassen aus Versorgungseinheiten, Signalquellen, Meßgeräten usw. Jedes Modul-Mitglied einer funktionellen Familie hat in seiner Steckerleiste eine zweite Aussparung, die seiner speziellen Familienzuordnung entspricht. Durch Einbau einer zweiten

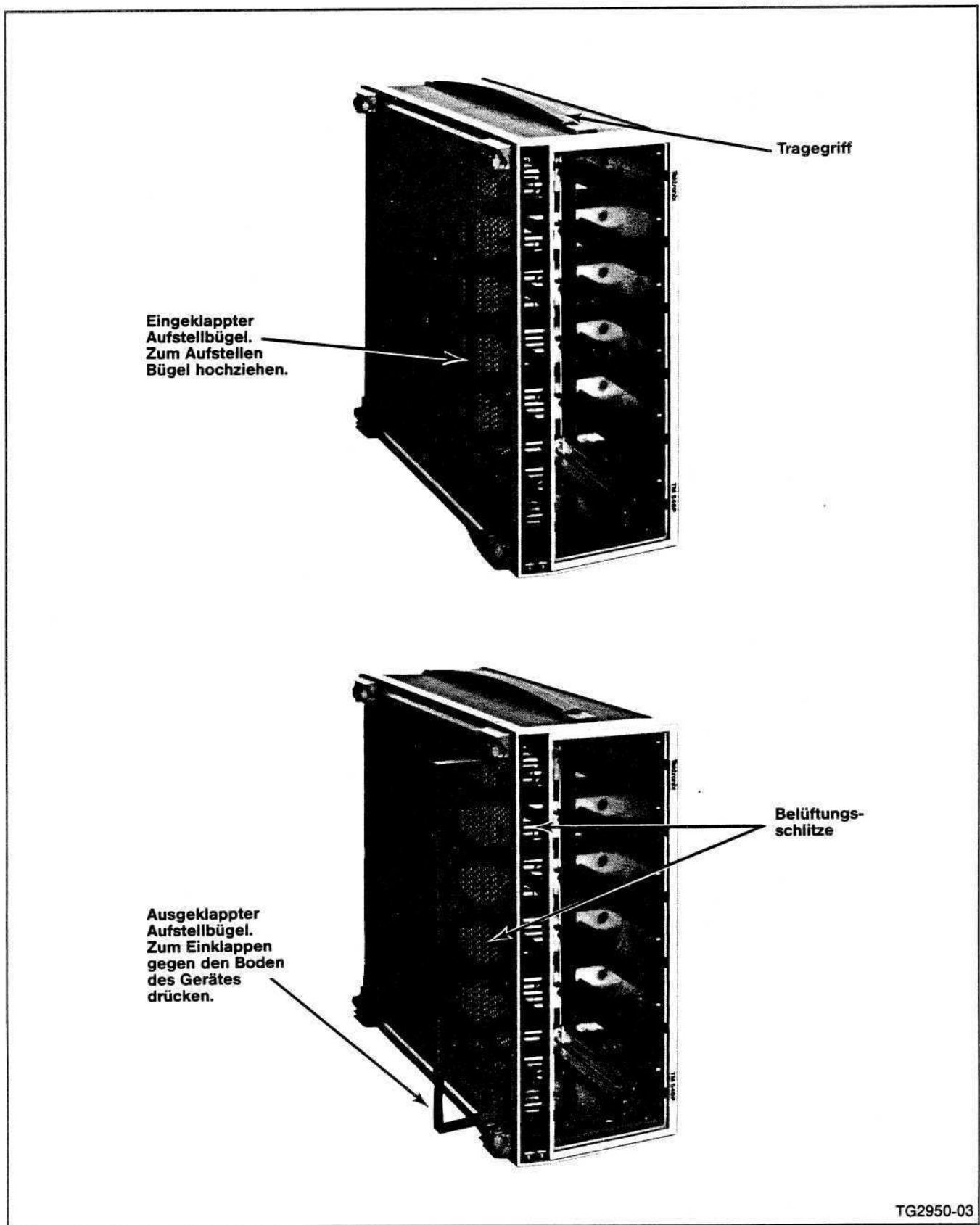

TG2950-03

Bild 2-3. TM 5006 Ansicht der Unterseite.



Bild 2-4. TM 5006, Option 10, Maße über alles.



Bild 2-5. Aussparungen für Haltefedern.

Sperre in der Schnittstellen-Steckerbuchse, kann der Anwender der TM 5006 eines oder mehrere Einschubfächer auswählen, die nur Mitglieder dieser Familie, mit der entsprechenden Aussparung in der Steckerleiste des Moduls, aufnehmen. Eine ganze TM 5006 Versorgungseinheit kann auf diese Weise für spezielle Funktionen aufgebaut werden. Extra Spernteile bestellen Sie mit der Tektronix Teile-Nr.: 214-1593-02.

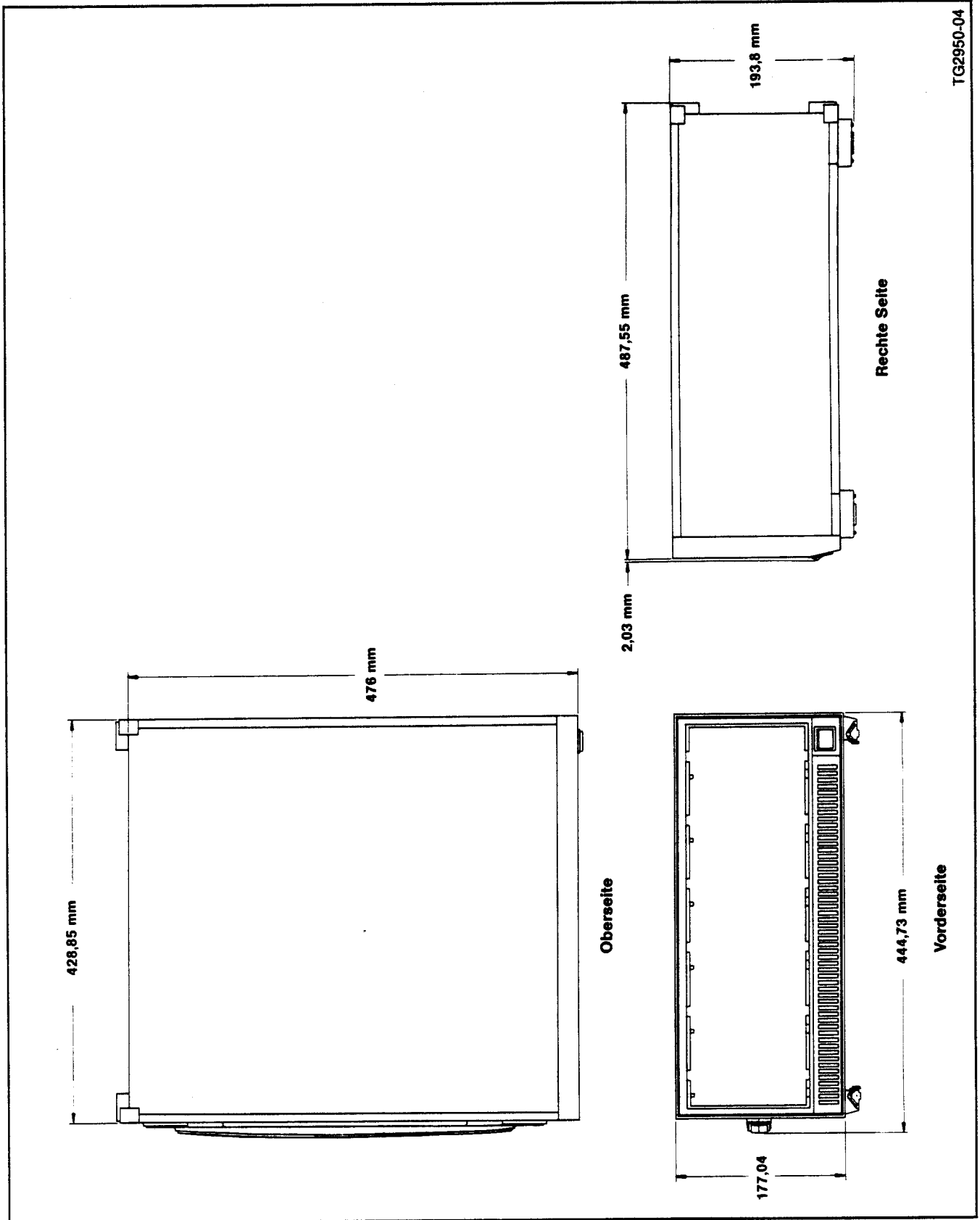
Geräterückseite

An der Rückseite des Gerätes befindet sich eine Montageplatte, auf der BNC- und andere Steckvorrich-

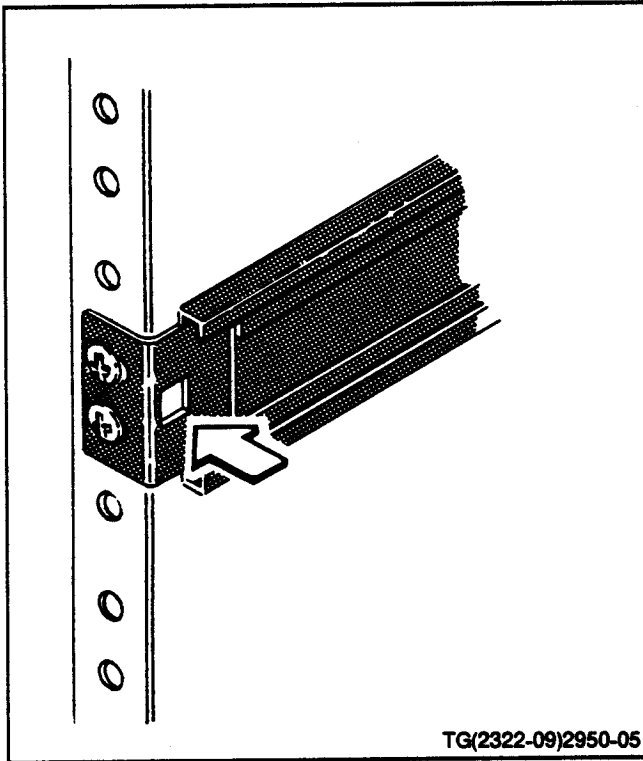
tungen angebracht werden können. Vom Kunden, oder werksseitig eingebaute Steckvorrichtungen und Verdrahtungen (Option 02), ermöglichen externen Zugang zur Schnittstelle. Diese Einrichtung macht das Modul-Geräte-System der Serie TM 5000 sehr flexibel bei der Verwendung in Tischgerätesystemen oder bei Gestelleinbau.

Option 02

Qualifiziertes Servicepersonal findet Informationen über Option 02 in Kapitel 6 im Serviceteil dieses Handbuchs.

Versandhinweise

Wenn das Tektronix-Gerät für Servicearbeiten oder zur Reparatur an ein Tektronix Service Center eingeschickt wird, befestigen Sie am Gerät einen Zettel mit Namen und Anschrift des Besitzers, sowie dem Namen einer Kontaktperson in Ihrer Firma. Geben Sie ferner die vollständige Seriennummer des Gerätes an und geben Sie eine Beschreibung der gewünschten Servicearbeiten.

Bewahren Sie die Originalverpackung Ihres Gerätes zur Wiederverwendung auf. Wenn die Originalverpackung unbrauchbar ist, oder nicht mehr zur Verfügung steht, verpacken Sie das Gerät wie folgt:

Wickeln Sie das Gerät zum Schutz der Oberfläche in eine Plastikfolie. Nehmen Sie einen Karton aus Wellpappe von ausreichender Festigkeit und mit Innenabmessungen, die wenigstens 15 cm größer sind, als die äußeren Abmessungen des Gerätes. Polstern Sie die Zwischenräume zwischen Gerät und Karton rundum mit Papierschnitzeln oder Schaumstoff fest aus. Verschießen Sie den Karton mit Klebeband oder Industrie-Heftklammern.

Die Prüffestigkeit des Kartons für dieses Gerät beträgt 24 kg/cm².



Bild 2-6. Maße und Einbaustelle für die TM 5006, Option 10, in einem Standard-Gestell.



Bild 2-7. Details der Gleitschiene. Wenn im Gestell Gewindelöcher vorhanden sind, werden die Gewindelaschen nicht benötigt.

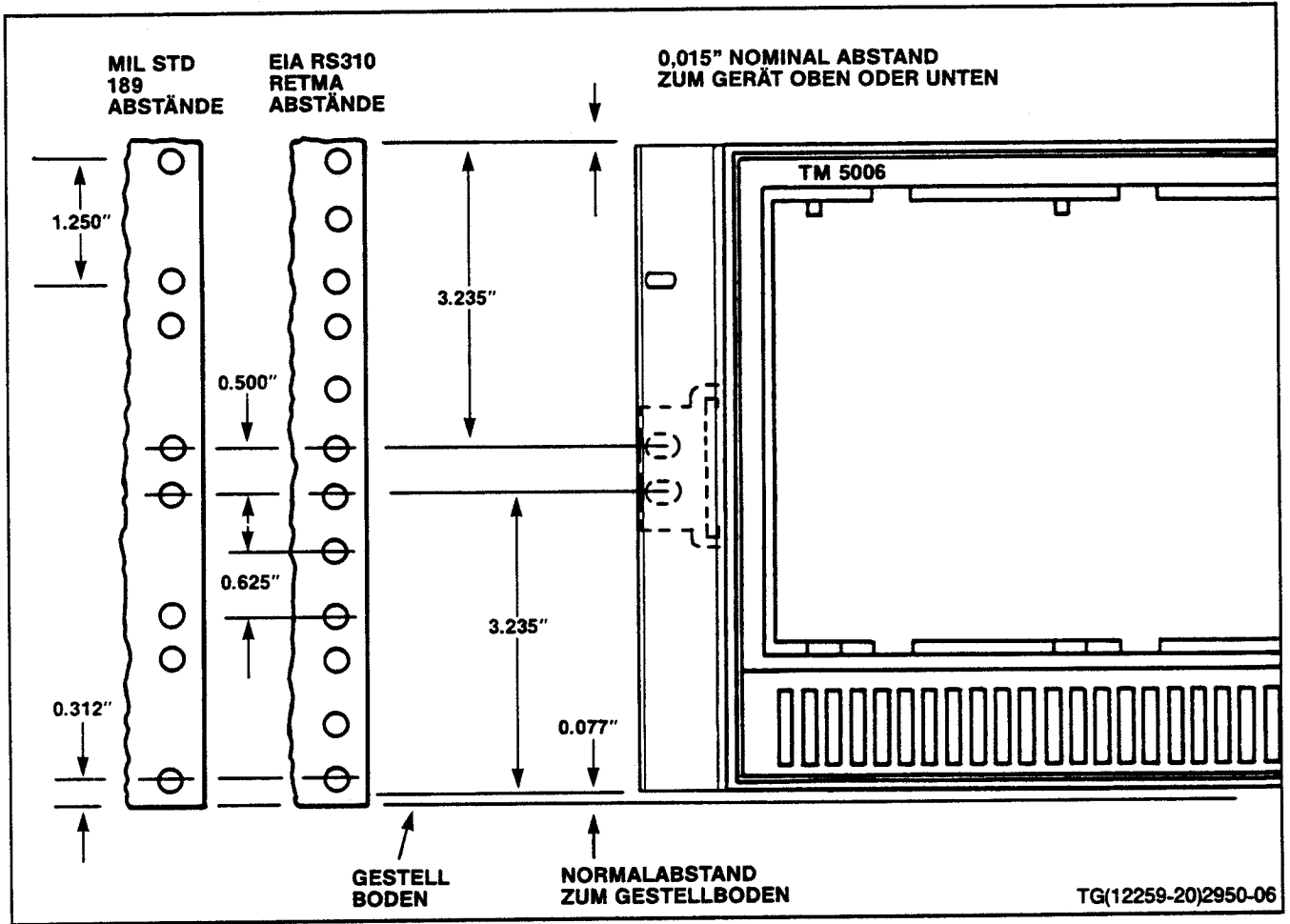

Bild 2-8. Gestelleinbau-Details.

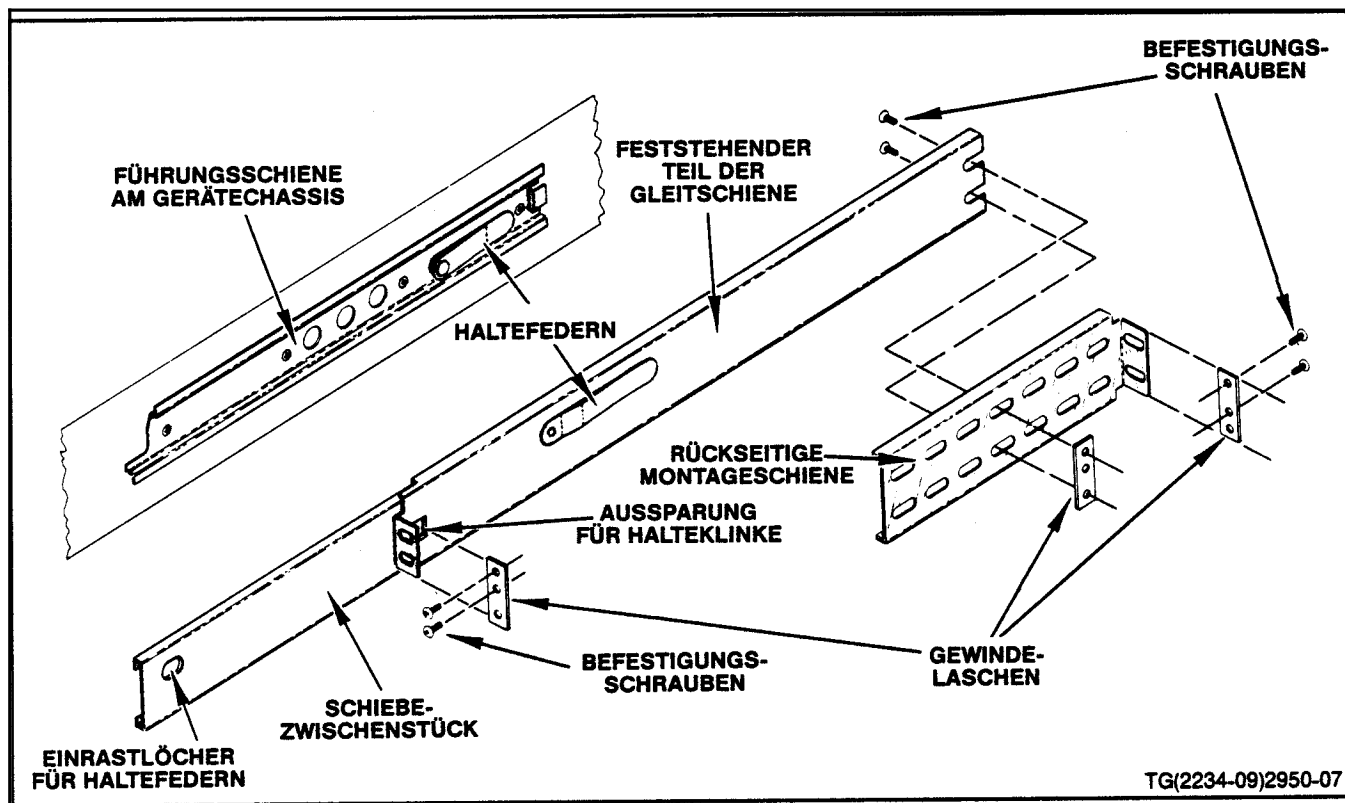

Bild 2-9. TM 5006, Option 10, Einsetzen und Herausnehmen aus den Gleitschienen.

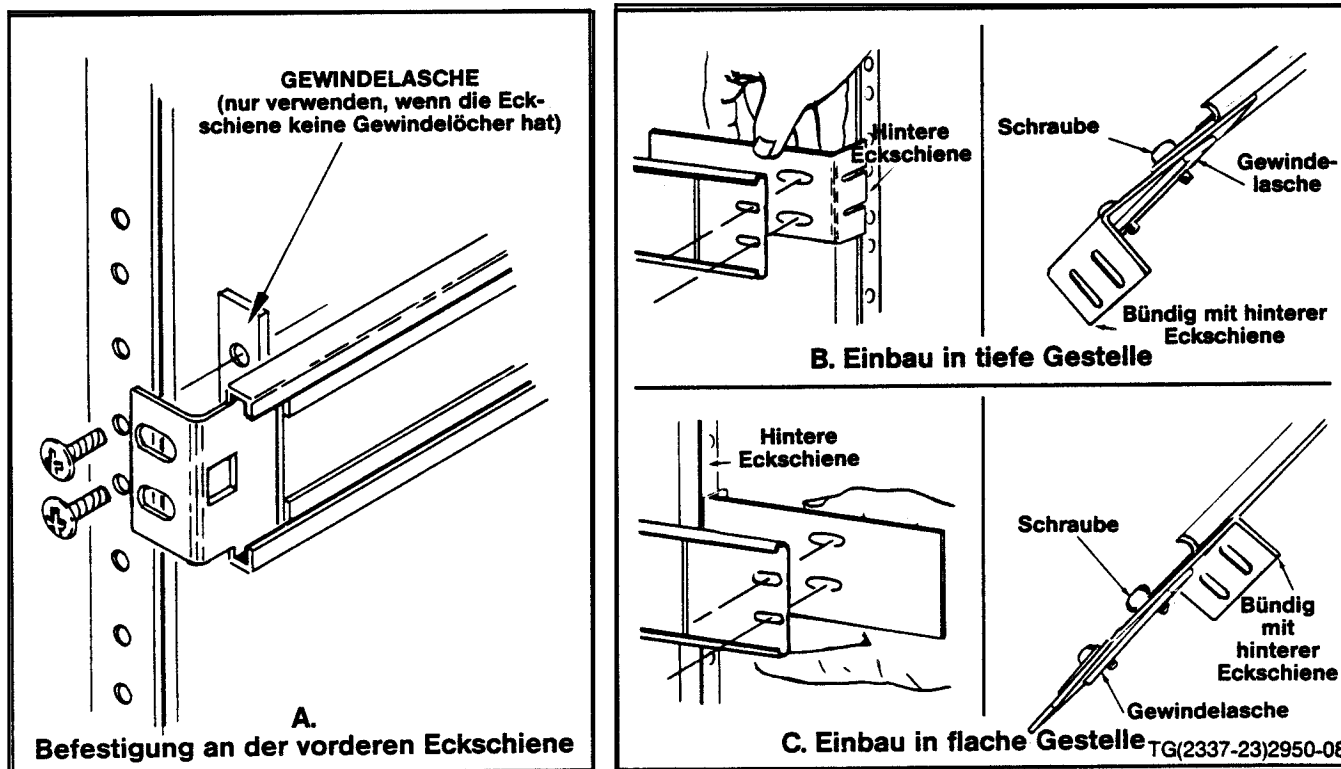

Bild 2-10. Ein- und Ausbau von Einschüben.

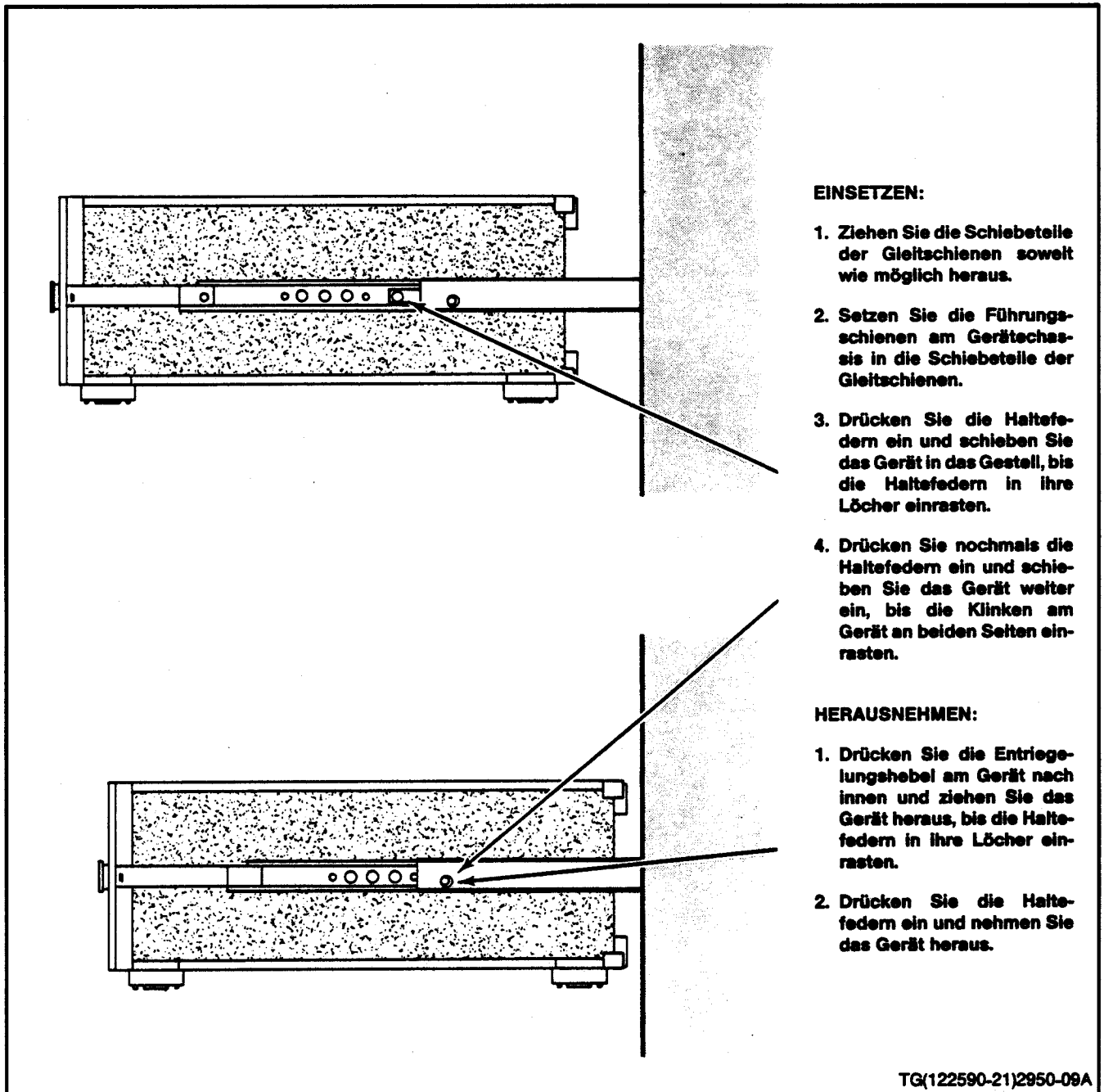

Bild 2-11. Anordnung der Sperren für Geräte-Funktionsgruppen. Eine von vielen Möglichkeiten.

取扱説明

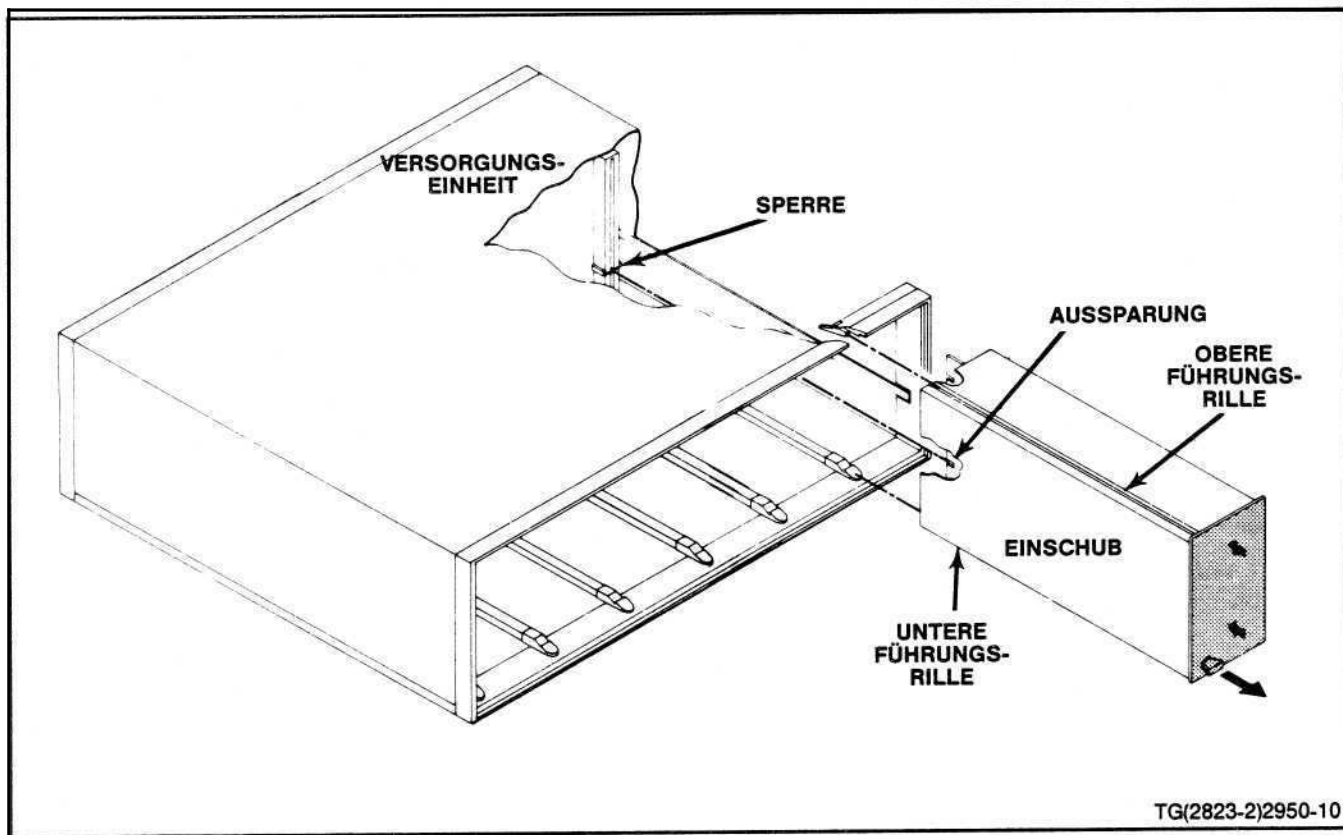
はじめに

TM5006型はTM5000シリーズの本体です。出荷時に校正されているので、すぐにご使用になれます。スタンダード・アクセサリと部品番号については、巻末をご覧ください。

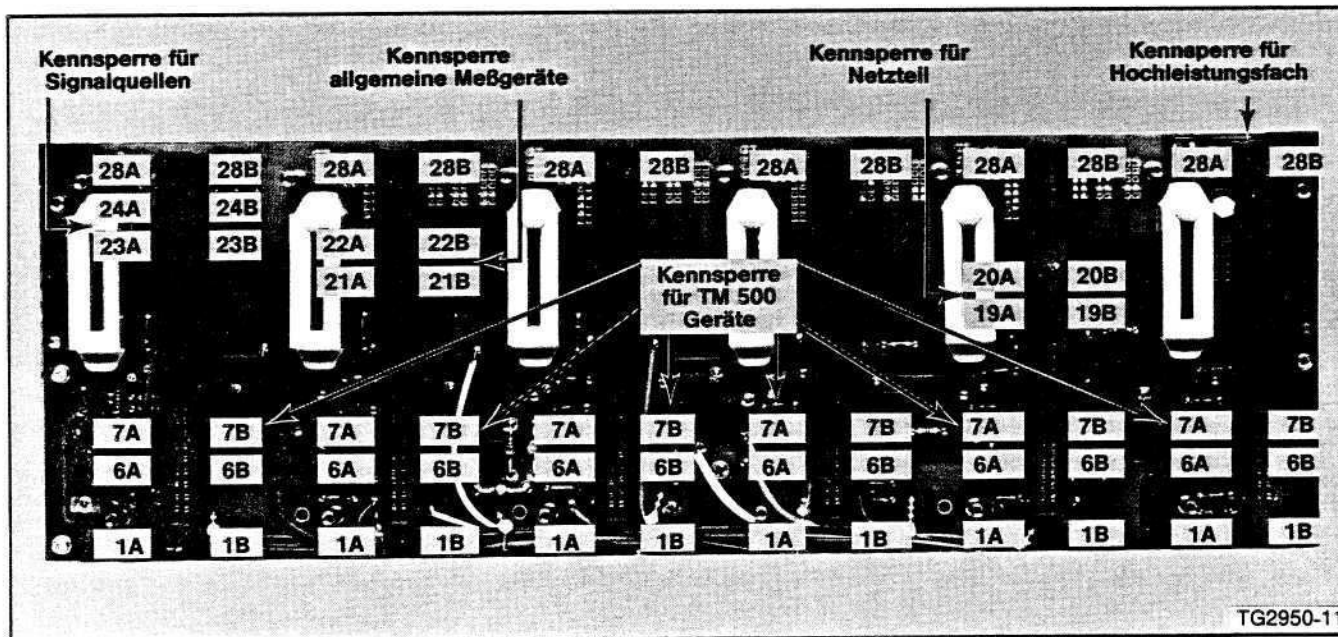
電源

警告

AC電源の接続—本機器は単相電源で使用します。電源との接続には、グラウンド・ラインのある3線式のコードとプラグを用います。電源ラインとグラウンド間の電圧は、最大250Vまでです。

電源に接続する前に、本機器が適切な電圧レンジに設定されているか、また規定の電源コードとプラグが使用されているかをお確かめ下さい。

接地—本機器はIEC(国際電気標準会議)により、安全性で第1級に選ばれています。手に触れそうな外面は電源コードとプラグのグラウンド・ラインにより、すべて接地されます。

電源プラグは、保護用の接地端子のあるソケットに差し込みます。グラウンド・ラインを切り放すと電氣的ショックを受けることがあります。危険です。

電氣的ショックを避けるため、他の機器と接続する前に、グラウンド・ラインを通して確実に接地させて下さい。

後部パネルにある電源電圧／ヒューズ選択表を参照して適切な電源電圧とヒューズでご使用下さい(図2-1参照)。

ヒューズ交換

後部パネルにあるヒューズ・ホルダを左方向に回転させるとヒューズが取り外せます。後部パネルの表示に従って適切なヒューズと交換して下さい。

ケーブルの接続

注意

ケーブルを接続する際、前もって本体の電源を切っておきます。

ケーブルは本体内部から後部パネルへ、放熱用の空気穴を利用して通すことができます(図2-2参照)。まず後部パネルにネジ止めされているアクセス・パネルを外します(図2-1参照)。次に底面パネルの2つのリテイナ・スクリューとリテイナを外すと、底面パネルは後方にずらせるようになります。内部の空気穴からケーブルを通し、プラグインの取り付けガイド・レールをくぐらせて、アクセス・パネルを外した穴から外に出します。ケーブルを通したら、底面パネルは元の位置に戻しておいて下さい。

注意

放熱用ファンが回っていることをお確かめ下さい。放熱のためにカバーを外して使用すると危険です。

机上でのご使用に

TM5006型を机上で使用する場合、操作しやすいように底面にあるスタンドを立てて前面部を持ち上げることもできます。図2-3をご参照下さい。

ラックへの取り付け

ラックの寸法—TM5006オプション10型は、ラックマウント型です。主な寸法については図2-4をご覧ください。図2-5は、ラックに固定する際にスプリング・ラッチをロックするためのラック・ラッチ穴です。

注

TM5006オプション10型のスライド・トラックには、スプリング・ラッチ用の穴があります。穴のないスライド・トラックを付けたまま、ラックに取り付けしないで下さい。

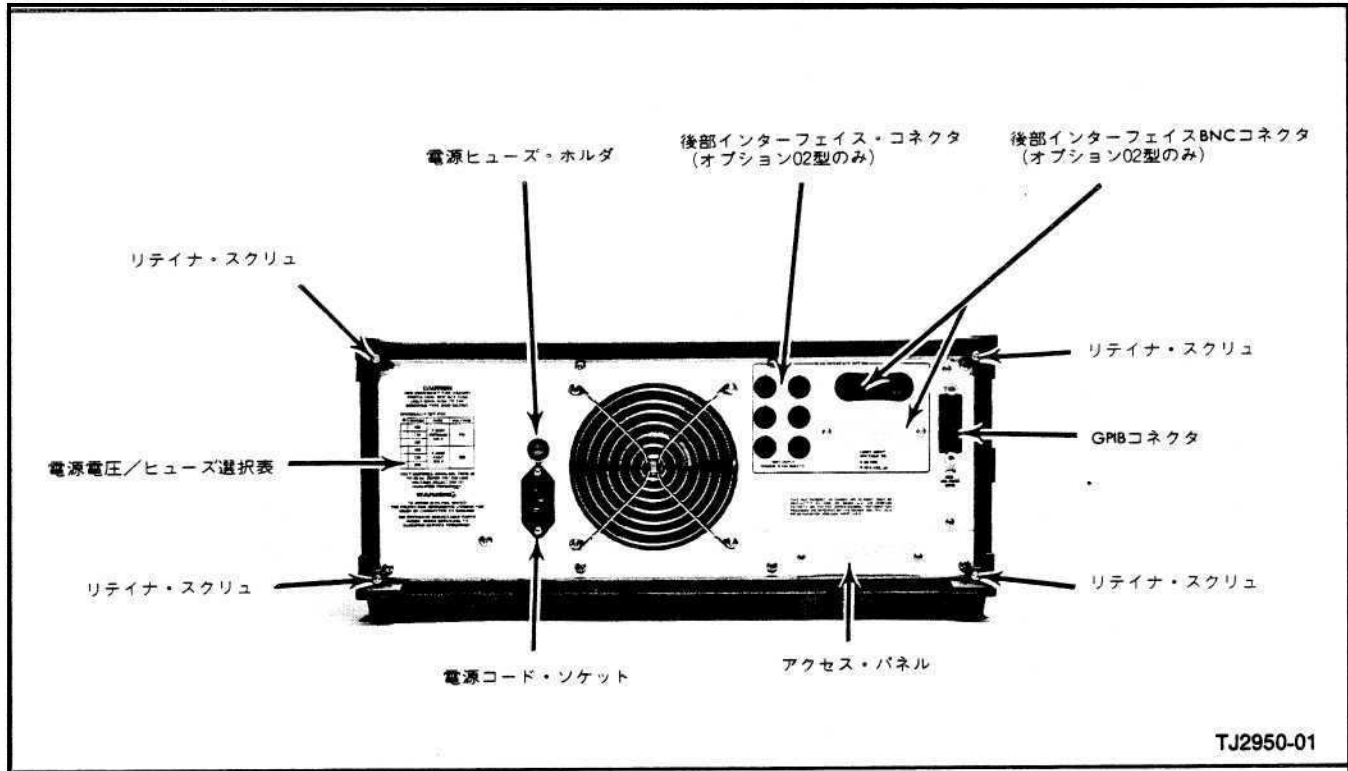

TJ2950-01

図 2-1 後部パネル

TM5006オプション10型は標準の19インチ(48.3cm)幅のラックに取り付けて使用します。前面左右のレール間隔は少なくとも17 $\frac{3}{4}$ インチ(45.1cm)が必要です。これだけの寸法があれば、ラック・スライドを取り付けて機器の両側のスライド・トラックを動かすだけの隙間が保たれ、機器を自由に出し入れできます。

付属部品を取り付けたラック・スライドは、前後のレール間隔が10 $\frac{1}{2}$ ~24 $\frac{1}{2}$ インチ(26.7~61.6cm)あるラックにそのまま取り付けられます。

ラック・スライドの取り付け—図2-6に示された寸法のラック穴に取り付けます。ラック穴間隔の規格には数種類あり、EIA規格のラックにラック・スライドを取り付ける場合は、間隔が $\frac{1}{2}$ インチ(1.27cm)の箇所を選びます。取り付ける際に必要なその他の寸法も図2-6に詳しく記されています。また取り付けに必要な金具類と取り付け方法を図2-7、8に示しました。なお図2-8のBとCは、奥行きが深いラックと、奥行きが浅いラックへの取り付け方法を示したものです。ラック・スライドの取り付けはTM5006型が水平になるように左右平行にする必要があります。

ラック・スライドへの取り付け—プラグインは本体から抜いておきます。スライド・トラックを図2-9に示す位置までいっぱい引き出します。本体にネジ止めされているフレーム・ガイドをスライド・トラックに差し込み、さらに押しと互いにロックした状態になります。スライド・トラックにあるストップ・ラッチ穴から突き出た左右のボタンを押しながら機器を押し込みます。これで取り付けが完了しました。スライド・トラックをスライド・ガイドから支えているラッチは、機器をラックに押し込む際、自動的にロック解除となります。またフレーム・ガイドのスプリング・ラッチは、機器を完全にラックに押し込んだ時、スライド・ガイドにあるラック・ラッチ穴に自動的にロックされます。

ラック・スライドからの取り外し—プラグインは本体から抜いておきます。前面パネル上部の2本のネジをゆるめます。前面パネルの左右にある長方形のラッチを引き、スライド・トラックがフレーム・ガイドとスライド・ガイドにロックするまで機器を引き出します。この位置で機器は固定します。ラックから完全に取り外すには、ストップ・ラッチ穴から見えるボタンを押してロックを解除し、機器を徐々に引き出します。



図 2-2 前面パネルおよび内部機構

ラック・スライドの調整—ラック・スライドの取り付け位置を適切に調整しておかないと、機器をラックに取り付けた後、スライド・トラックが動かなくなってしまうことがあります。この場合、前面パネルがラック前面から10インチ(25.4cm)の距離になるまで機器を引き出し、ラック・スライドを前面のレールに支えている左右のネジを徐々にゆるめていきます。ラック・スライドを正常な位置まで調整したらネジを締め付け、機器を前後にずらして滑らかに動くようになったことを確かめます。

ラック・スライドの保守—ダーク・グレイのラック・スライド表面は、特殊な永久潤滑仕上げになっているので注油の必要はありません。

プラグインの取り付けと取り外し

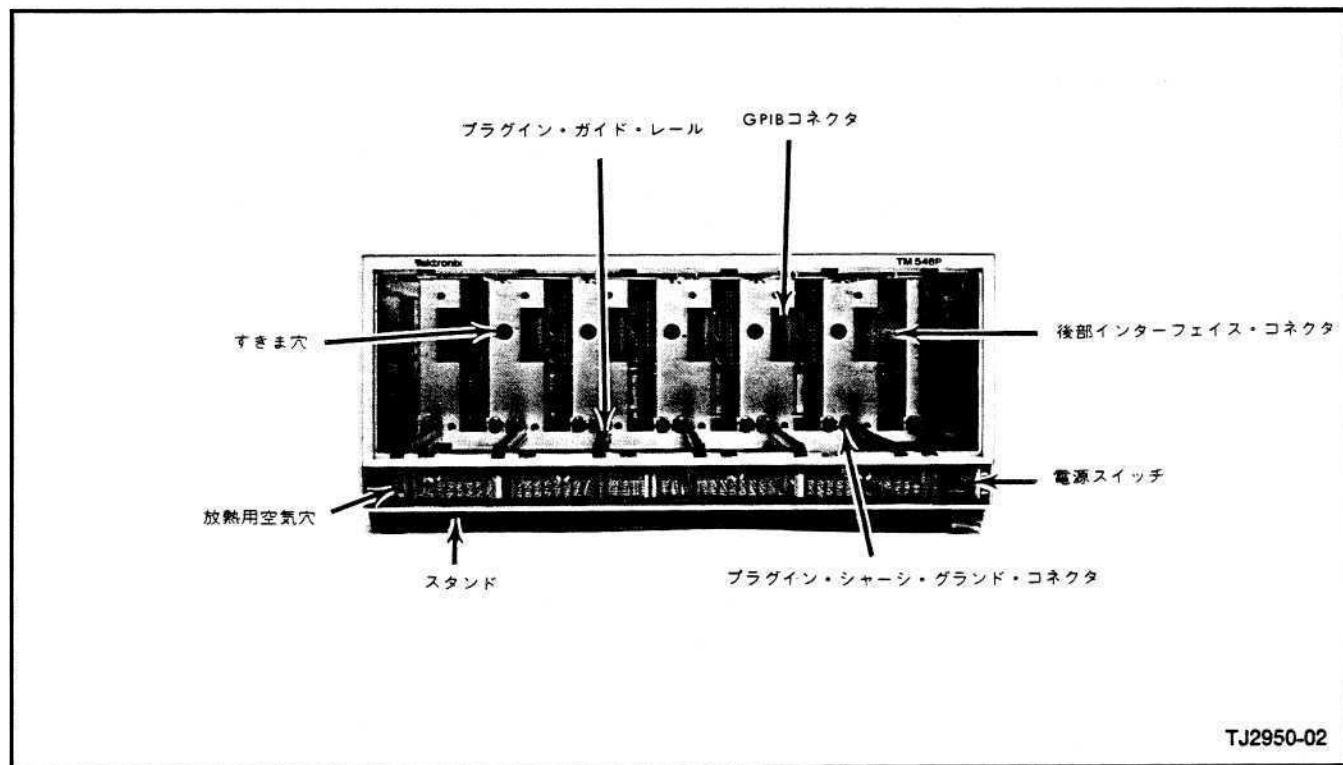
注意

プラグインを取り付けたり取り外したりする場合は回路への悪影響を考慮して、前もってTM5006型の電源を切っておきます。

注

TM5006型にはDC505型、DC505A型、LA501W型プラグインは使用できません。

プラグインを正しい位置に取り付けるためのTM5006型コネクタ・キーと、プラグイン側のボード・コネクタにある切り込みが対応する位置にあることを確かめます。1番右側のプラグイン・ホールは高電力供給用となっています。上下の取り付けガイドに従ってプラグインを挿入し(図2-10参照)、コネクタに差し込んだら、さらに押し込むようにして本体にしっかり固定させます。

プラグイン規格

TM5000シリーズのプラグインは、機構的には当社の他のシリーズのプラグインによく似ています。ところが電気的には異なる仕様で設計されています。そのため、TM5006型のインターフェイスは、コネクタの6ピンと7ピンとの間にキーを設け、適合しないプラグインが挿入できないようにしてあります(図2-11参照)。適合するプラグインには、ボード・コネクタの6ピンと7ピンとの間に切り込み

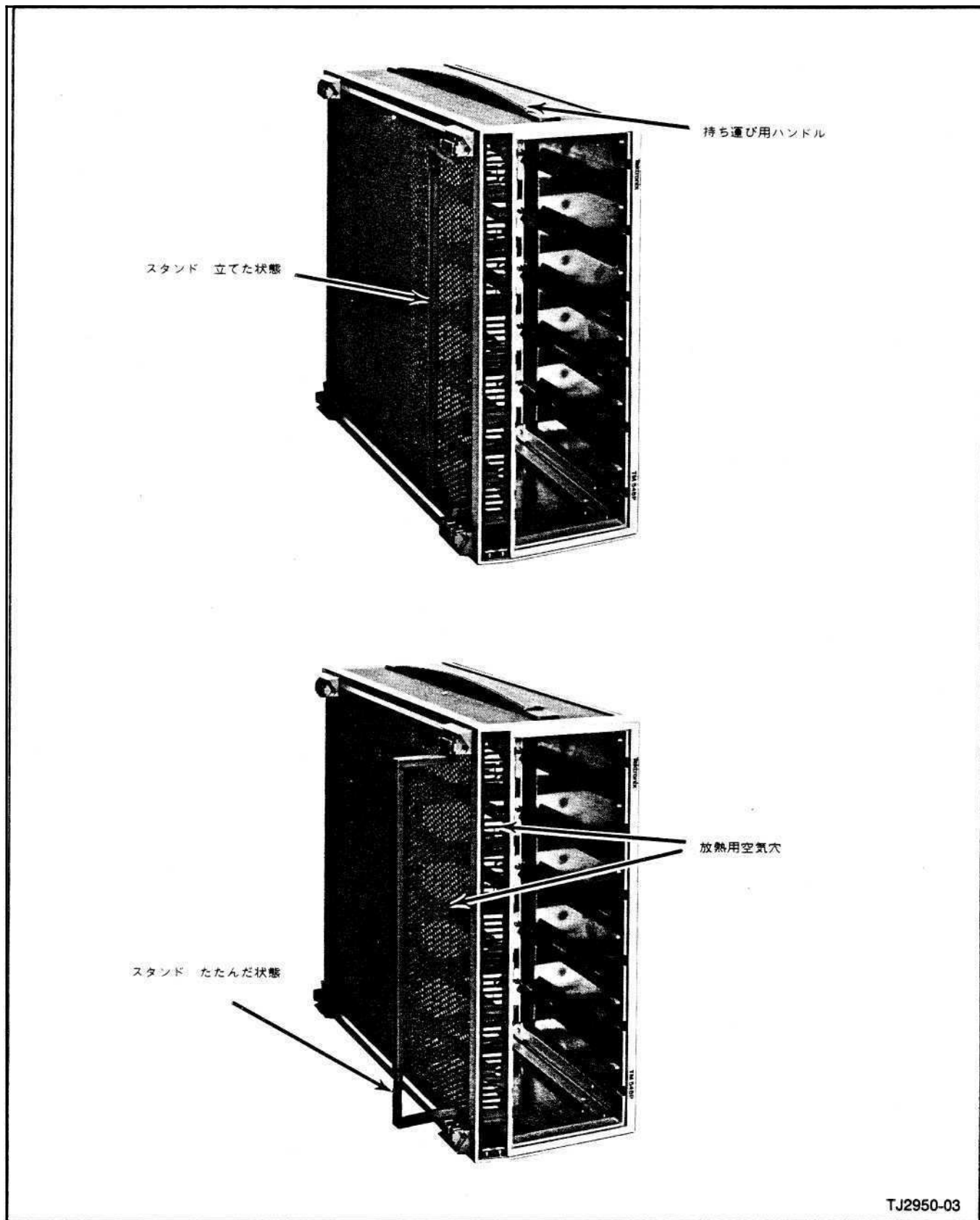

TJ2950-03

図 2-3 側面および底面パネル

インチ-メートル換算表

インチ	.080	6.970	7.630	16.884	17.509	18.740	19.195
ミリメートル	2.03	177.04	193.80	428.85	444.73	476.00	487.55

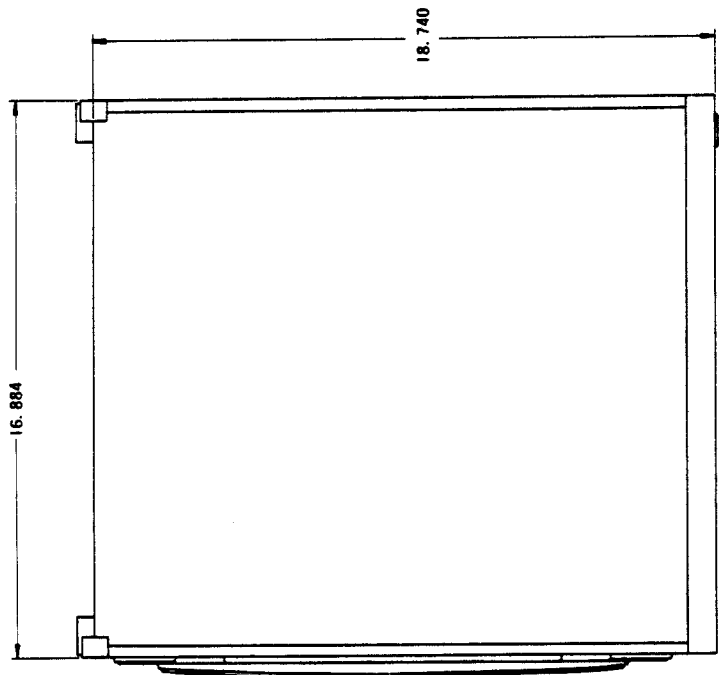

上面

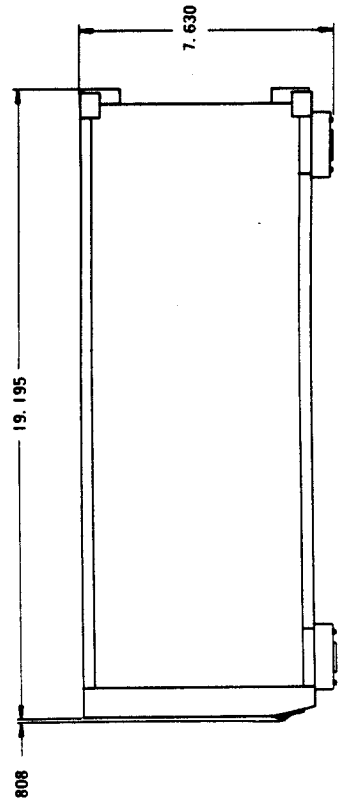

側面

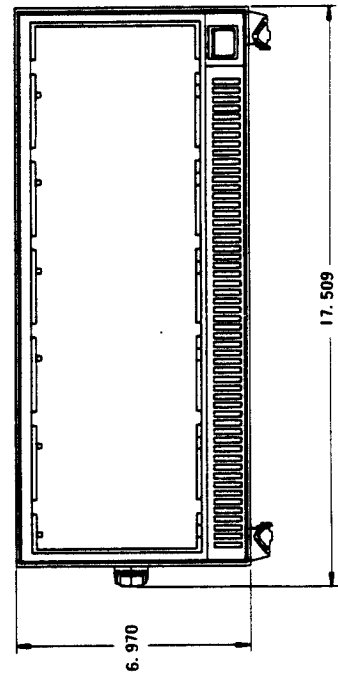

前面

図 2-4 オプション10型寸法図



図2-5 ラック・ラッチ穴

があり、完全に挿入できるようになっています。このキーと切り込みの位置で適合するプラグインが決まります。

インターフェイス機能

TM5006型と各プラグインを使ったシステムには、それぞれの持つ特徴を生かした多様な機能を組み込むことができます。プラグインは本体に組み込む場合、機能別にいくつかの種類に分けて使うことができます。この機能別分類を「ファミリー」と呼びます。例えば電源用、信号源用、測定器用等です。これらのプラグイン・ボード・コネクタには前述した切り込みの他に、ファミリー別に指定したもう1つの切り込みを入れることができます。また本体のインターフェイス・コネクタには、その切り込みに対応した位置にファミリー・キーを設け、同じファミリーのプラグインのみが組み込めるようにしておけます。TM5006型は、このよう

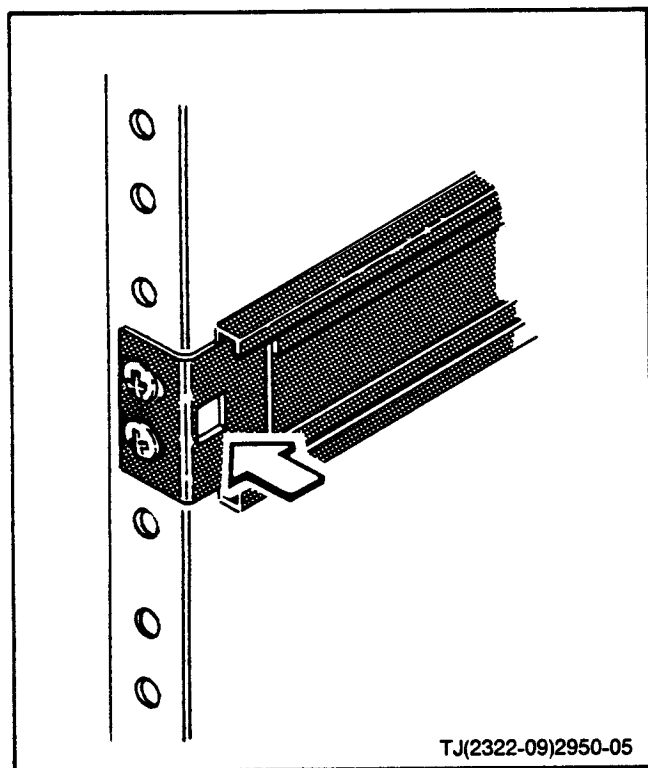
な方法で各プラグイン・ホールに特定の機能を持たせることができます。なお、予備用のコネクタ・キーも用意されております(部品番号：214-1593-02)。

後部パネル

後部サブパネルにはオプション02型用のBNC、およびマルチピン・コネクタの取り付け位置にアルミ板がネジ止めされています。オプション02型ではこの位置に各コネクタを取り付けて配線しますが、これらを通して本体のインターフェイスに外部から働きかけることができます。この機能の追加により、TM5000シリーズ総合テスト・システムはベンチ型、あるいはラックマウント型として応用がさらに広がることとなります。

オプション02型

オプション02型についての詳細は第6章「オプション」をご参照下さい。

再梱包の方法

機器の保守や修理を当社へご依頼になる時に梱包の必要がある場合、連絡のための住所、会社名、担当者のお名前、さらに機器の番号とご依頼内容を必ずお書き添え下さい。

納入された時の梱包材料をそのままお使いになれます。それ以外のもので再梱包する場合、次のように行います。

まず、ポリエチレン製のシートで機器の外面をすべて覆います。カートンは輸送に耐え得る強度があり、機器の寸法より6インチ(15cm)ほど大きい内径を持つダンボール製のものを用います。カートンと機器のすべての面との間にウレタン・フォーム等を詰め込んで衝撃を防ぎます。最後に、荷造り用のテープや金具でカートンのふたをしっかりと閉じます。

梱包用カートンには約14kg/cm²の重量に耐えられる強度が必要です。



図 2-6 オプション10型 ラックへの取り付け位置寸法



図 2-7 ラック・スライド詳細図(1)

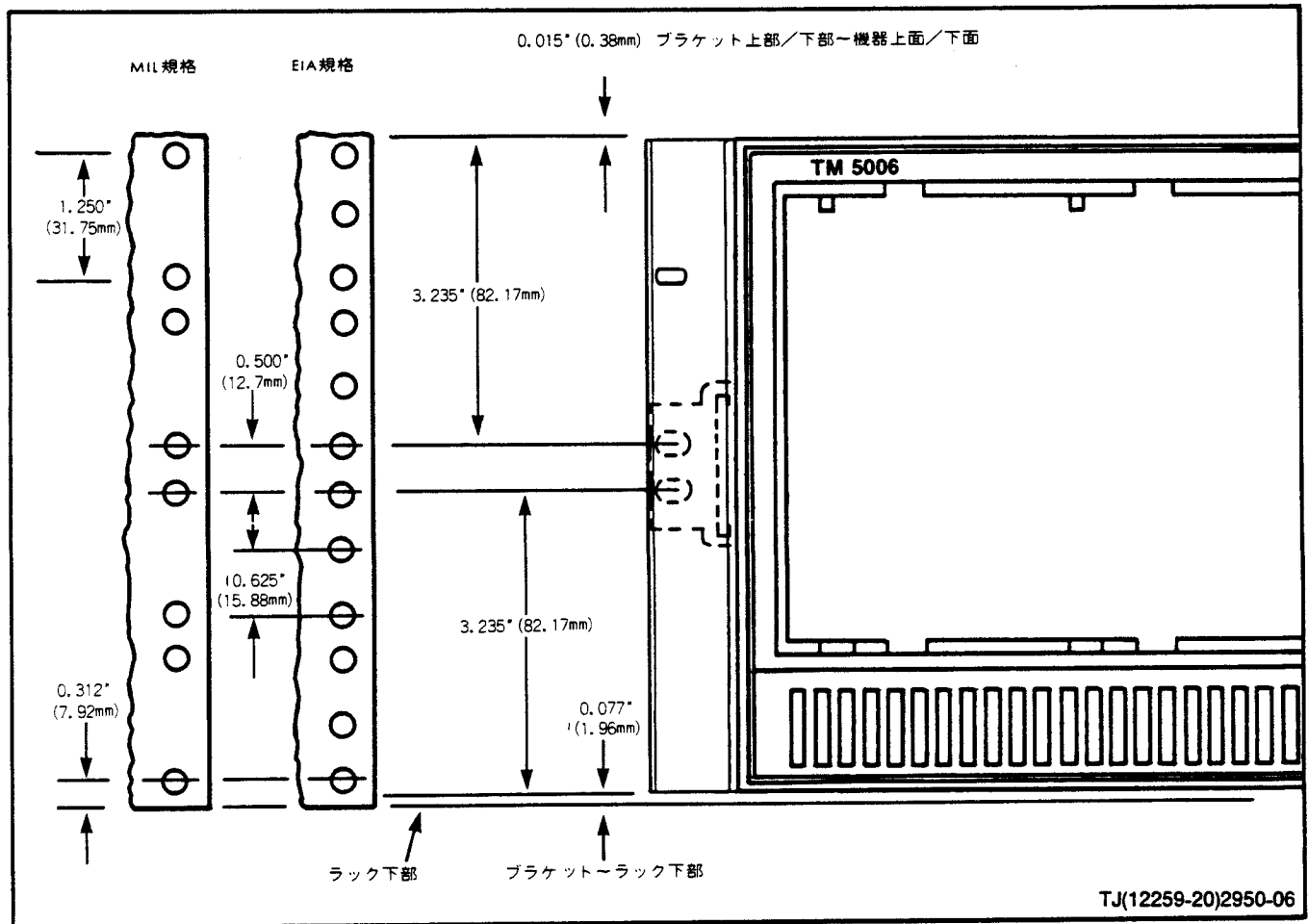

図 2-8 ラック・スライド詳細図(2)

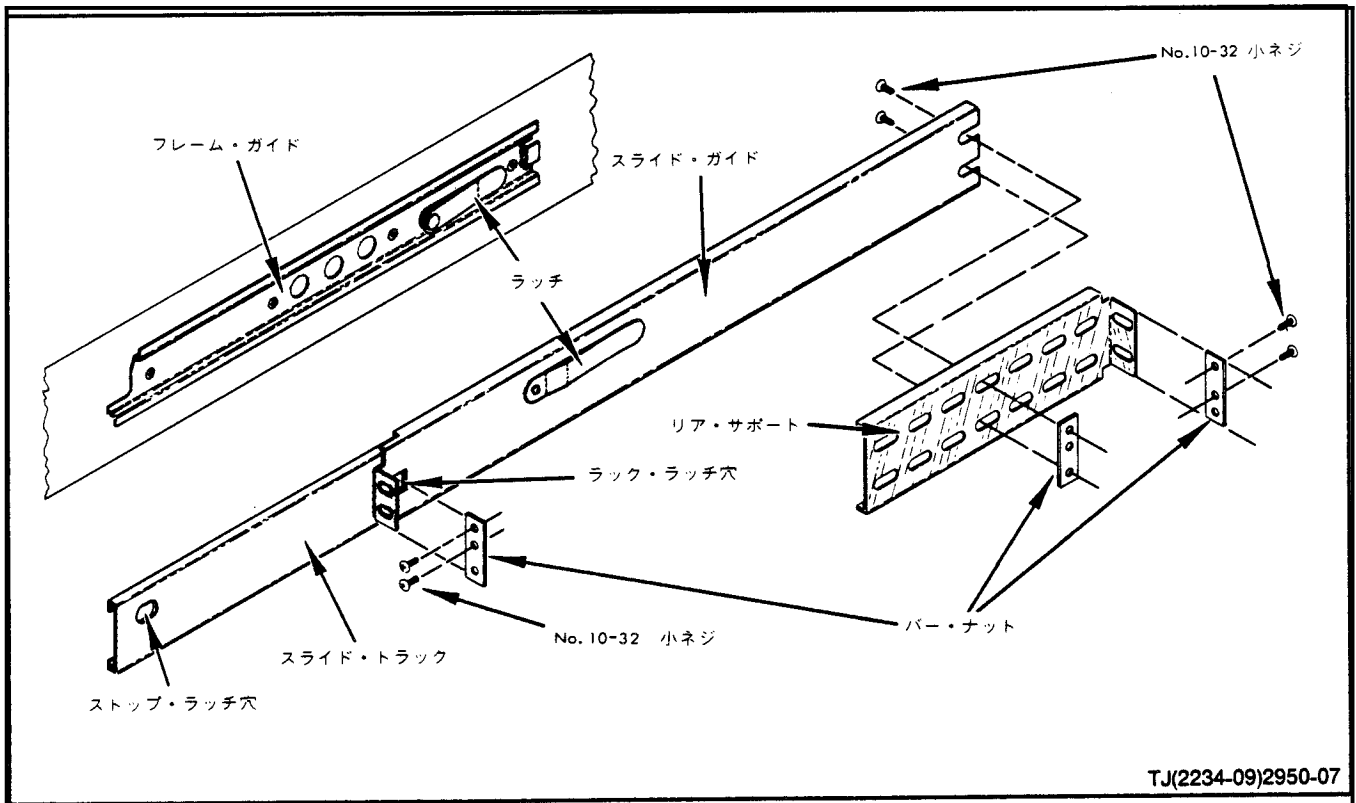

図 2-9 オプション10型 取り付けと取り外し

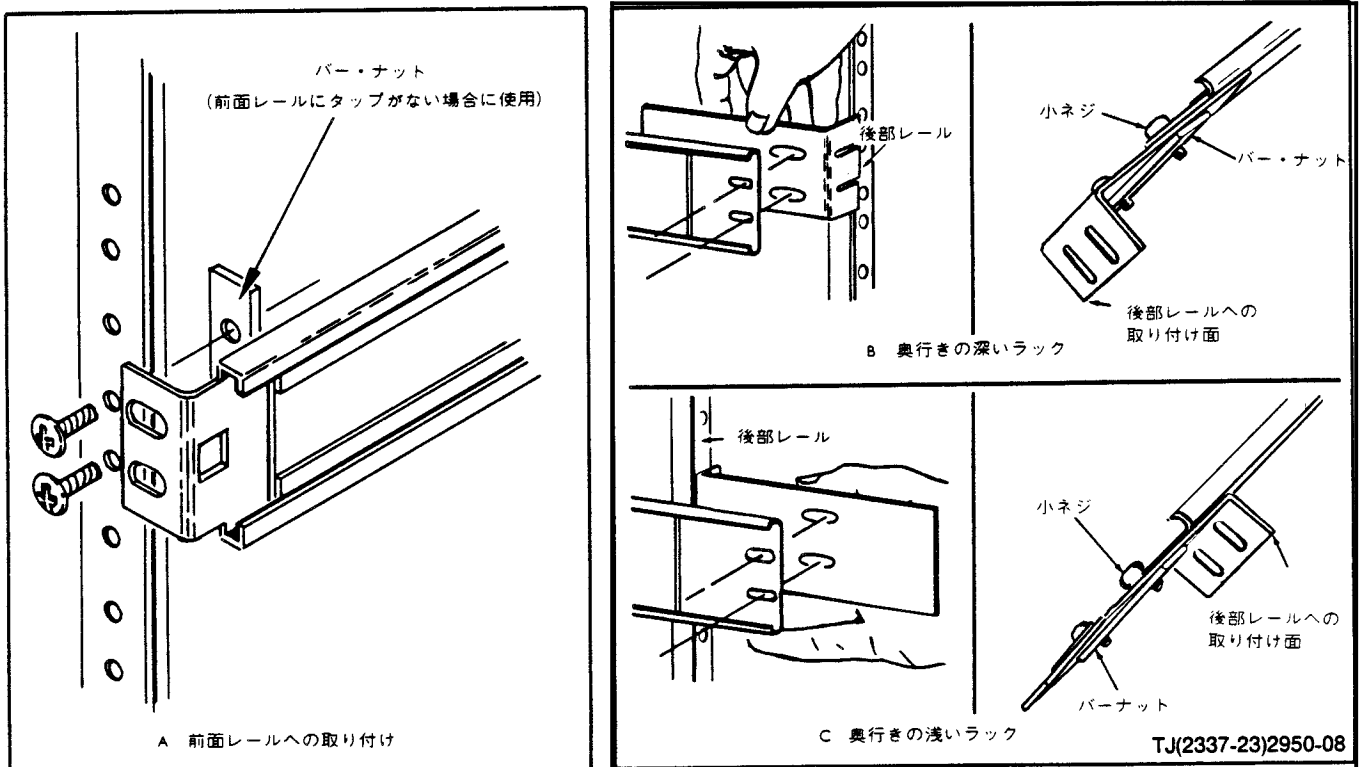

TJ(2823-2)2950-10

図 2-10 プラグインの取り付けと取り外し

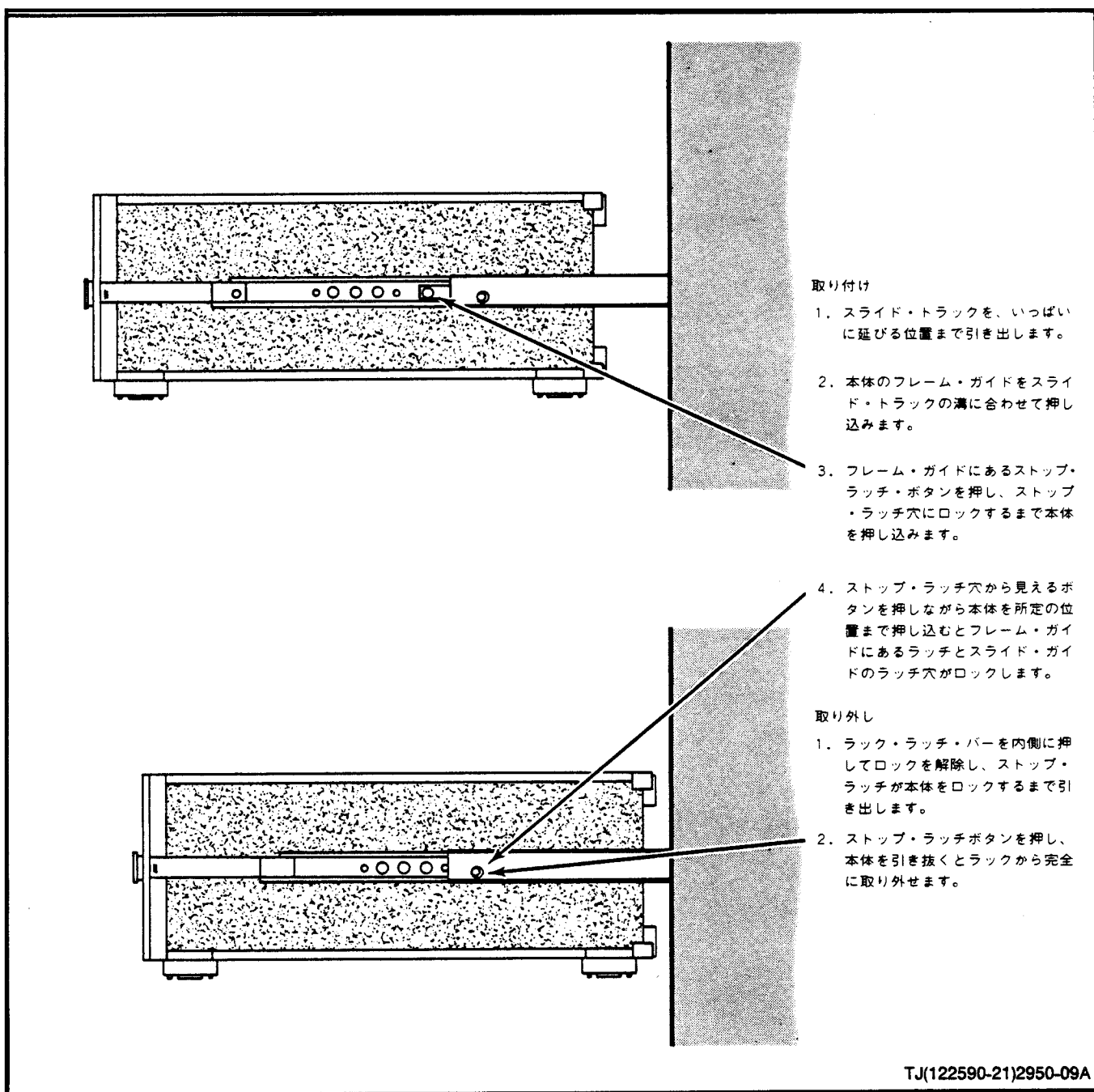
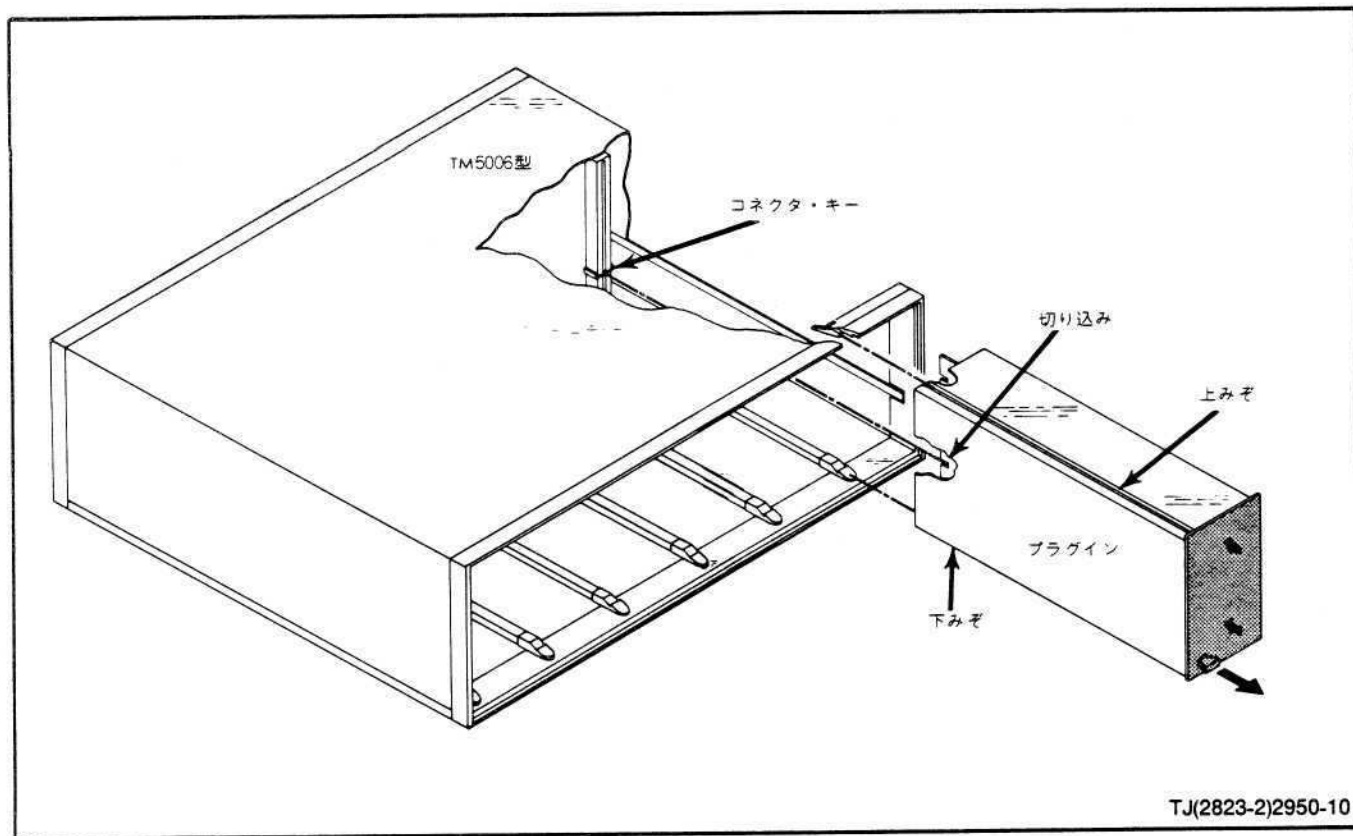
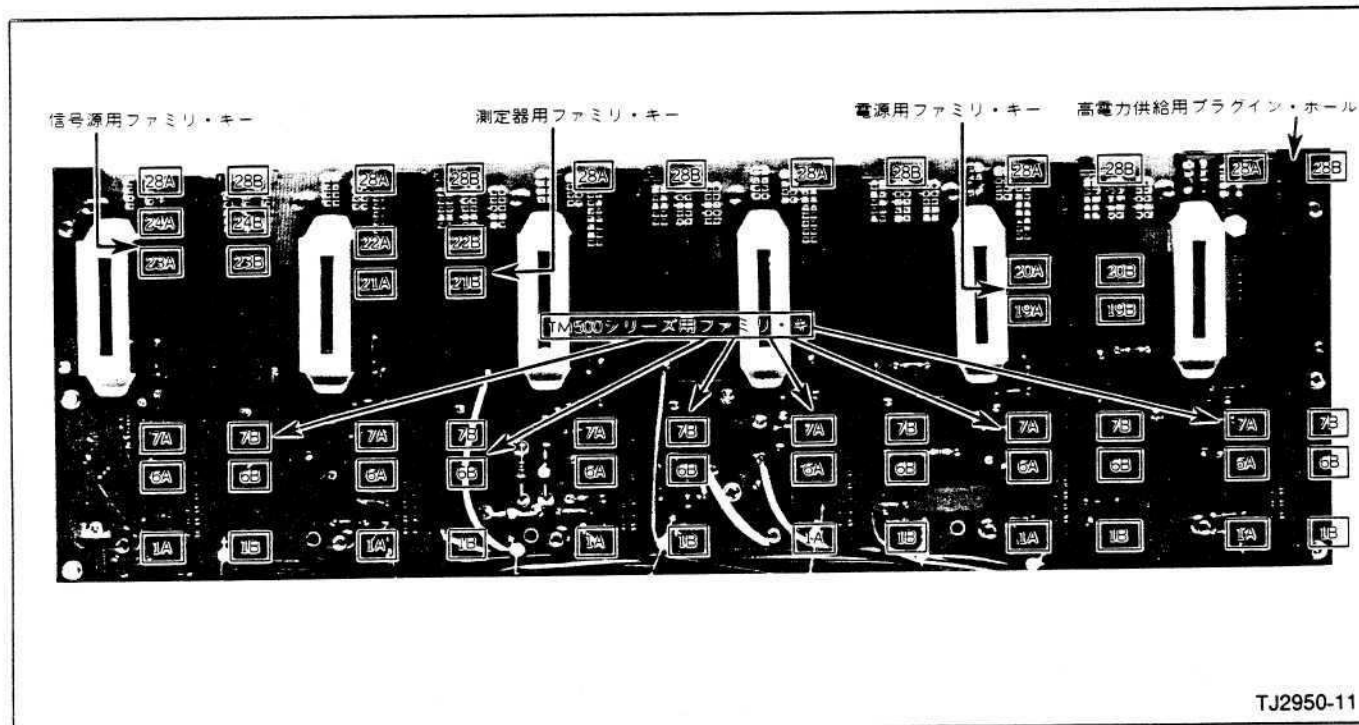

TJ2950-11

図 2-11 ファミリ・キーの割当て例

WARNING

THE FOLLOWING SERVICING INSTRUCTIONS ARE FOR USE BY QUALIFIED PERSONNEL ONLY. TO AVOID PERSONAL INJURY, DO NOT PERFORM ANY SERVICING OTHER THAN THAT CONTAINED IN OPERATING INSTRUCTIONS UNLESS YOU ARE QUALIFIED TO DO SO. REFER TO OPERATORS SAFETY SUMMARY AND SERVICE SAFETY SUMMARY PRIOR TO PERFORMING ANY SERVICE.

THEORY OF OPERATION

Introduction

For ease in understanding, this description refers to the schematics located in the pullout pages at the rear of this manual. Also refer to the block diagram located in the pullout pages and the timing diagram in Fig. 3-1. Each block in the block diagram is outlined on the schematics.

The TM 5006 uses a pulse width modulated switching supply for dc voltages. A 60 Hz transformer provides the ac voltages necessary for plug-in operation. Connections to the six plug-in compartments as well as the series pass transistors are shown on schematic .

Line Selector and 60 Hz Transformer

Ac power is applied to the voltage select terminals through FL500 and a discrete line filter composed of T1050, L1030 and L1020. Line transients are filtered to ground through C1120 and C1140.

The two primary windings on T500 are connected in parallel for 115 V operation or in series for 230 V operation. Winding taps are provided for various line voltages around the nominal values. The secondaries provide ac voltages to the various plug-in compartments.

Rectifiers and Filters

The ac line voltage is applied through negative temperature coefficient resistances RT1000 and RT1200 to the rectifier diodes. As these resistances are highest when cold, the surge currents, charging the high voltage capacitors when line voltage is applied, are limited, thus preventing component failure. These resistors then self heat to a low resistance.

In 220 V operation the four diodes function as a bridge rectifier. See Fig. 3-2. When the voltage-select-circuit is set for 110 V operation, only the two series diodes operate. The circuit then becomes a voltage doubler with an output of approximately 350 V dc. The neon bulb in this circuit flashes to indicate when dc voltage is present.

The rectified and filtered dc is applied through L1320 and C1240, a low pass filter, and passes through R1430 and CR1540, to the collector of Q1640.

20 kHz Output Stage

The output stage is a half bridge type with proportional base drive. The turns ratios and phasing of T1740 are such that only a small amount of base drive power is needed to start conduction in either Q1640 or Q1650. Positive feedback from T1740 supplies base current for the remainder of the power cycle. When both base drive transistors, Q1730 and Q1731, (shown on schematic ) are saturated, T1740 is essentially shorted, terminating base current for either output transistor. Output transistors Q1640 and Q1650 alternately conduct at a 20 kHz rate. Their on and off times are adjusted by the regulation circuitry. Diodes CR1550 and CR1551 prevent base to collector current flow in Q1640 and Q1650 at turn off. The base switching action of these transistors is improved by networks C1530 and R1530 for Q1640, and C1560 and R1460 for Q1650. A series resonant filter between the transistors and the output transformer, T1710, is composed of C1430 and L1440. During Q1640 and Q1650 off time, the tank current generated by L1440 and C1430 passes through CR1541 and CR1551.

The 20 kHz output voltage is stepped down to the correct levels by T1710.

Three sets of full wave diode rectifiers are provided for each of the three dc voltage outputs. Schottky diodes are used in the +8 V supply for reduced forward voltage drop. All filters are L-C pi-sections. Bleeder resistors are provided for all filter capacitors.

Control Logic and Drivers

U1840E and U1840F are inverting amplifiers. Their outputs control the base drive transistors Q1730 and Q1731. Collector voltage for these transistors is applied from the 10 V bus through a center tapped winding on the base drive transformer (T1740). Reverse polarities across Q1730 or Q1731 are prevented by CR1730 and CR1731. When either one or both of these transistors (Q1730, Q1731) are on, either one or both of the output transistors (Q1640, Q1650) are off. The bases of Q1730 and Q1731 are also controlled, through R1832 and R1950, by the collector of Q2240. During power up or power down, the collector of Q2240 goes positive. This action turns Q1730 and Q1731 on to turn the output transistors off. This is necessary as the control circuitry state is undefined during power up or power down.

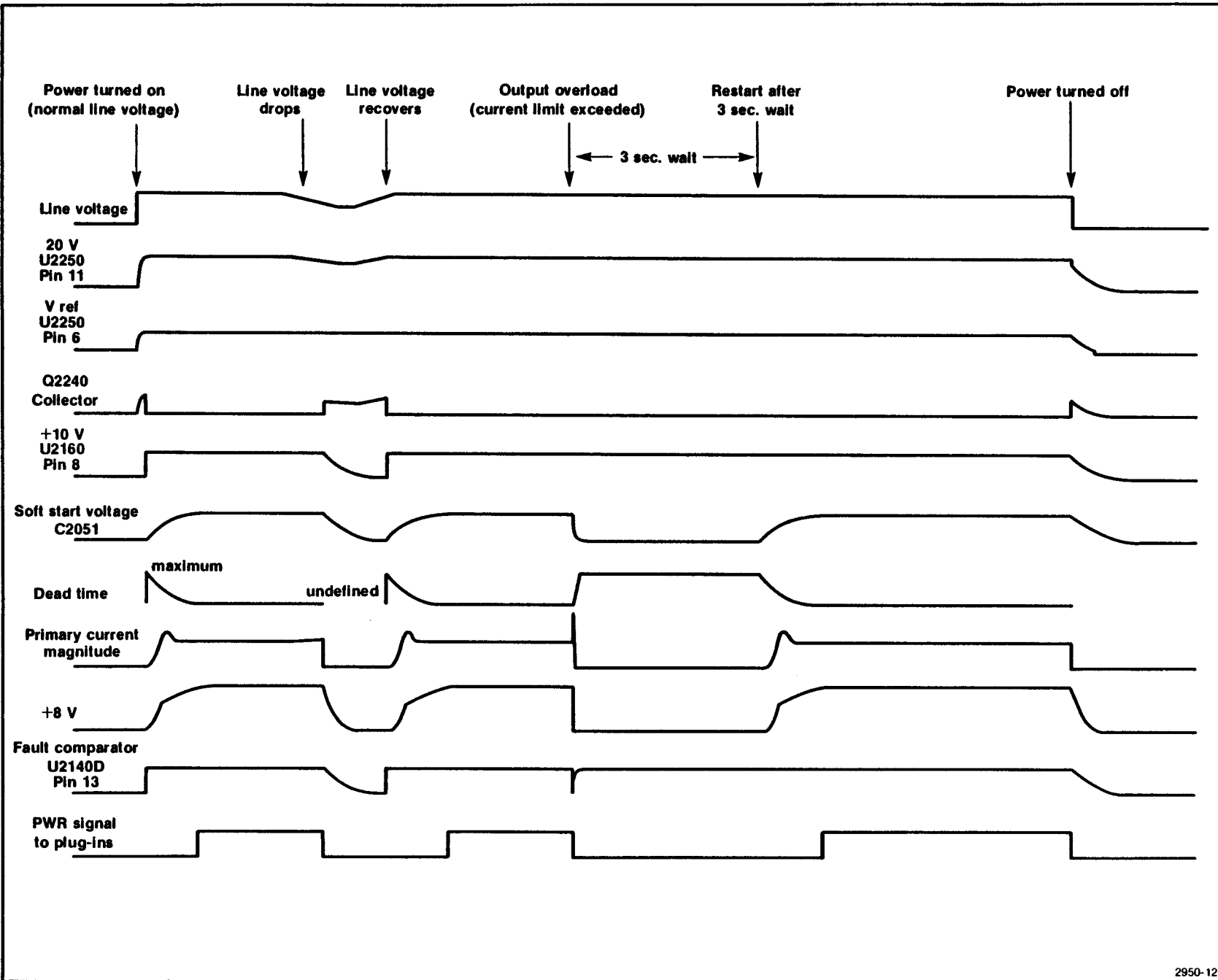

Fig. 3-1. Various waveforms and time relationships for power on, off, fault and low line.

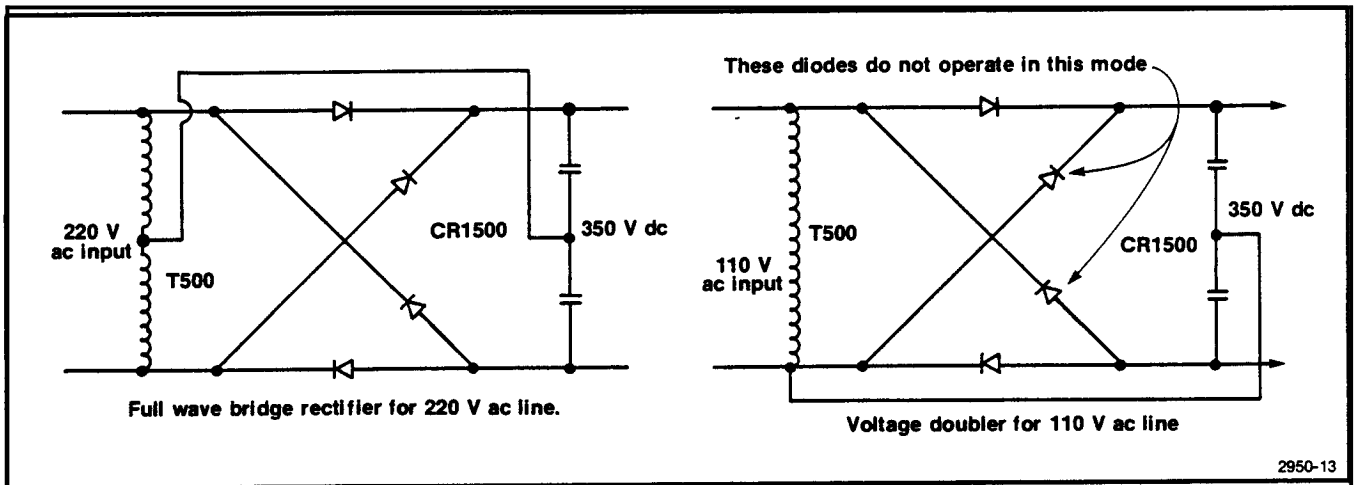

Fig. 3-2. Input line connections for 110 V and 220 V operation.

When pins 1 of U1950A and 13 of U1950B are low, no drive is applied to the output stage. With one gate output high and the other low, base drive is applied to one output transistor. Input pins 4 and 11 connect to the wait flip-flop, U1940A. Input pins 3 and 12 connect to U1940B, the dead time multivibrator. Input pins 5 and 10 connect to the output of the stop monostable, U1951A. Pins 2 and 9 connect to the complement outputs of the divide-by-2 flip-flop, U1951B. With any one or all of these inputs high, the output lines are low and no drive is applied to one or both of the output transistors.

The dead time multivibrator circuitry determines the minimum off time of the output transistors. Dead time is necessary to allow one output transistor to completely turn off before the other turns on. At start up, the A input (pin 12) of U1940B goes low. This allows U1940B to trigger on the clock signal at the B input (pin 11). The minimum timing period of U1940B, determined by R1930 and C2040, is 5 μ s. This pulse width is lengthened by C2050, CR2040 and CR2043 as the voltage on C2051 and C2060 is decreased. The pulse width of the power supply output varies for soft start and power limit. When pin 10 of U1940B is high, both output transistors are off.

Dead time or output transistor off time is maximum with C2051 and C2060 discharged and minimum charged. The output power available gradually increases as these capacitors charge during soft start. The soft start keeps high input currents to capacitors from damaging circuit components. When pin 6 of the wait multivibrator U1940A goes high for any reason (fault), pin 8 of U1840D goes low discharging C2051 and C2060. Under normal operation, when power is turned on, C2051 and C2060 charge to the voltage at pin 8 of U1840D as determined by R1953 and R2060. This takes approximately 1/2 second.

The power limit control is R2060. For maximum power, this control must be in the fully clockwise position (maximum resistance). For servicing the control can be adjusted for reduced power output levels. This is accomplished by reducing the resistance of R2060, limiting the voltage across C2051 and C2060.

The purpose of flip-flop U1951A is to vary the on time of the output transistors consistent with the output voltage level. When pin 6 of U1951A goes high, pin 1 also goes high. This action shuts down the base drive circuitry, reducing power output. The length of time pin 6 remains high is controlled by the Output Regulator circuitry. The rising portion of the waveform at pin 4 of U1951A resets the flip-flop for a low condition at pin 1.

Flip-flop U1951B divides the 40 kHz output waveform from U1940B to 20 kHz. The pulse from the dead time multivibrator, U1940B, is applied to the clock terminal (pin 11) of U1951B. The Q terminal of U1951B is connected to its D input. The multivibrator U1951B toggles on the rising edges of the dead time multivibrator (U1940B) output.

Output Regulator

2

The 40 kHz clock oscillator, which provides the basic timing necessary for the control circuitry, is composed of U1840A, B and C. Feedback goes from pin 6 of U1840C and pin 4 of U1840B to pin 1 of U1840A. The output voltage at pin 4 of U1840B is high for about 4 μ s and low about 21 μ s. This non-symmetrical duty cycle is accomplished by CR1850 and is necessary for proper operation of U1940B.

The positive going output pulses from the clock oscillator charge C2150 to about 9.5 V through CR2042. When the positive pulse at pin 4 of U1840B drops to 0 V, C2150 discharges through R2050 causing a falling ramp waveform of about 50 mV peak-to-peak amplitude to appear at pin 4 of U2140A.

The +8 V from the power supply output is applied to voltage adjust potentiometer R2151. The voltage on pin 4 of U2140A is +7.15 V, the reference voltage generated in U2250. Also, on pin 4 is a negative going 40 kHz ramp, as previously described. This ramp is ac coupled to pin 4 through C2140. On the rising edge of each clock pulse, the ramp goes positive rapidly. Pin 2 of U2140A is low. At some point, during the ramp decay, the ramp voltage and the feedback voltage at pin 5 are equal. At this point, pin 2 goes high, terminating the drive pulse through the logic circuitry. The higher the output voltage, the earlier in the ramp cycle pin 2 goes high.

Overvoltage and Overcurrent Detectors

2

Pin 11 of U2140D, the negative over-voltage-detector, connects to a voltage divider between the -26 V supply and the reference +7.15 V. Should pin 11 go more negative than pin 10, pin 13 goes low shutting off the output. The input of U2140D is protected from a negative voltage by CR2130.

Primary current in output transformer T1710 flows through T1750. The secondary voltage of T1750 is proportional to the primary current. The secondary voltage of T1750 is rectified by CR1860, CR1861, CR1862 and CR1863 and terminated in R1860. When the primary current in T1750 exceeds the point where the voltage at pin 6 of U2140B exceeds the 7.15 V reference at pin 7, pin 1 goes low turning off the output transistors via the wait multivibrator.

The +26 V is applied through R2231 and CR2240 to pin 8 of U2140C, the positive over voltage detector. The +8 V is also applied through R2130 and CR2230 to pin 8. Pin 9 of comparator U2140C connects to the +7.15 V reference voltage. If pin 8 of U2140C goes more positive pin 14 goes low. This action triggers U1940A the wait multivibrator, turning the supply off for about 3 seconds. The soft start cycle follows. This negative going pulse is time delayed by R2040 and C2052.

When +10 V is applied at power up, C1940 holds pin 3 (clear) of U1940A low for a short period. This over-rides the A and B inputs of U1940A, causing pin 6, the Q output, to remain low. Over-voltage or over-current causes a low at pin 4 of U1940A causing one high level pulse of about 3 seconds duration at pin 6. This 3-second pulse duration time is determined by C1930 and R1931. The clock pulse

retriggers U1940A if the fault persists. The purpose of CR1950 is to discharge C1940 when ac power is removed from the supply. Noise from the limit circuitry is filtered by C2052.

Control Circuit Regulator

2

The 16 Vac winding on T500 is applied through F2340 to rectifier diode CR2341, which charges filter capacitor C2260 to approximately 20 V. The +20 V is applied to voltage regulator U2250. This regulator outputs two voltages: +10 V which is used throughout the entire supply, and +7.15 V, a reference voltage, at pin 6.

The line detector circuitry is composed of CR2340, C2350, Q2240 and associated components. When normal line voltage is applied, the voltage across C2350 is approximately 20 V. Transistor Q2240 is on and pin 2 of U2250 is about 0.2 V above ground. If about two cycles of line voltage are missed or the line voltage goes low, Q2240 no longer saturates. The collector of Q2240 rises, disabling the series pass transistor located internally in U2250. This series pass transistor is effectively connected between pins 11 and 10 of U2250. The +10 V is removed from the power supply during line drop out to prevent discharge of the main filter capacitors in the output stage. Positive feedback is provided through R2241 to the base of Q2240 to improve the switching action.

The PWR signal circuitry (U2160) provides a signal to each compartment in the power module to give power supply status information to the plug-ins. See the rear interface information part of the Maintenance section (Section 5) of this manual for timing information.

Pin 7 of U2160 goes low when the rising voltage at pins 2 and 6 reaches 2/3 of the value of the voltage connected to pin 4 (+10 V). Pin 7 of U2160 connects to the base of Q1525. This transistor inverts the signal from pin 7 to the plug-in compartments.

When the line power goes low or off, pin 13 of U2250 goes low. This action raises pin 7 of U2160 turning off the PWR signal. Pin 7 of U1940A is also low during the 3 second wait state. The cathode of CR2150 is pulled low which turns off the PWR signal.

The soft start feature also controls the PWR signal. This is accomplished through R2061.

When a fault occurs, pin 6 of U1940A goes high. When the fault is removed pin 6 of U1940A goes low causing pin 8 of U1840D to go high. As the voltage at the junction of R2061 and R1953 goes high pins 6 and 2 of U2160 also go high causing the PWR signal to go high.

Main Interface 

The various ac and dc supply voltages as specified are available at the rear interface connectors for each plug-in

compartment. Each compartment has a PNP and an NPN transistor intended as series pass elements. Connecting pins to these elements are shown on the schematic.

CALIBRATION

PERFORMANCE CHECK PROCEDURE

Introduction

This procedure checks the Electrical Performance Requirements as listed in the Specification section in this manual. Perform the internal adjustment procedure if the instrument fails to meet these checks. If recalibration does not correct the discrepancy, circuit troubleshooting is indicated. Also, use this procedure to determine acceptability of performance in an incoming inspection facility.

Performance check may be done at any ambient temperature between 0° C and +50° C.

Test Equipment Required

The test equipment listed in Table 4-1, or equivalent, is suggested to perform the performance check in the adjustment procedure.

WARNING

Dangerous voltages are present inside this instrument. Exercise caution as this procedure requires removal of the power supply cover.

Test Loads for the Performance Check Procedure

To do the performance check procedure, the supplies must be loaded. Maximum load for the +8 V supply is 18A and for the 26 V supplies 6A. Maximum dissipation from these loads is 144 W and 156 W. The total power draw from any combination of the +8 V and ± 26 V supplies is

180 W or 30 W per compartment. Figure 4-1 shows suggested loads. Any combinations of resistors with sufficient dissipation is satisfactory. Connect the loads to the instrument with not over 1.5 feet for each lead. Use 12 AWG for the 8 V load and 16 AWG for the 26 V load. The ground lead should not exceed 1.5 feet of #12 AWG or larger. For convenience, use quick disconnect terminals to connect the loads to the voltage buses in the instrument (Tektronix Part No. 131-1563-00).

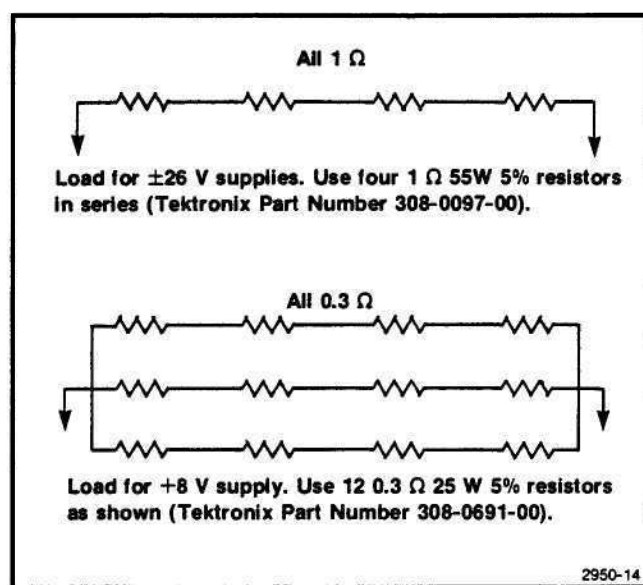

Fig. 4-1. Possible loads for use in performance check procedure. See text.



Signature Not Verified

Digitally signed by
<http://www.aa4df.com>

PERFORMANCE CHECK SUMMARY SHEET

This sheet may be duplicated and used as a short form performance check procedure. Perform the check and record the reading in the "Measured" column. Compare the reading with the upper and lower limits. After maintenance or adjustment again perform the procedure and compare the readings.

Date _____

Serial Number _____ Tested by _____

Step	Description	Minimum	Measured	Maximum

Table 4-1
SUGGESTED TEST EQUIPMENT

Description	Minimum Requirements	Performance Check Step	Adjustment Procedure Step	Recommended Equipment
Digital Multimeter	+8 V, -26 V, +26 V	All	1	TEKTRONIX DM 505
Test Load Unit		All		See text
Variable Voltage Transformer	1000 VA capability	All	1	VARIAC W10MT3W Autotransformer, General Radio USA



As considerable heat is generated in the test loads do not apply power longer than necessary to complete tests.

1. Check +26 Vdc

- a. Connect the test equipment as shown in Fig. 4-2. Adjust the line voltage to the TM 5006 for 10% below the nominal line voltage. (Nominal line voltage is the line voltage the instrument is set to operate on.)
- b. Set the +26 V load for maximum.
- c. CHECK—that the dvm reads from +23.7 V to +28.3 V.
- d. Change the line voltage to 7% above nominal.
- e. Remove the load from the supply.
- f. Set the +8 V load for maximum.
- g. CHECK—that the +26 V supply reads from +23.7 V to +28.3 V.
- h. Remove the connections to the +26 V bus for the next step.

2. Check -26 Vdc

- a. Connect the test equipment as shown in Fig. 4-2. Adjust the line voltage to the TM 5006 for 10% below the nominal line voltage.

- b. Set the -26 V load for maximum.
- c. CHECK—that the dvm reads from -23.7 V to -28.3 V.
- d. Change the line voltage to 7% above the nominal line voltage.
- e. Remove the -26 V load from the supply.
- f. Set the +8 V load for maximum.
- g. CHECK—that the supply reads from -23.7 V to -28.3 V.
- h. Remove the connections to the -26 V bus for the next step.

3. Check +8 Vdc

- a. Connect the test equipment as shown in Fig. 4-2. Adjust the line voltage to the TM 5006 for 10% below the nominal line voltage.
- b. Set the +8 V load for maximum.
- c. CHECK—that the dvm reads from +7.6 V to +8.5 V.
- d. Change the line voltage to 7% above the nominal.
- e. Remove the load from the supply.

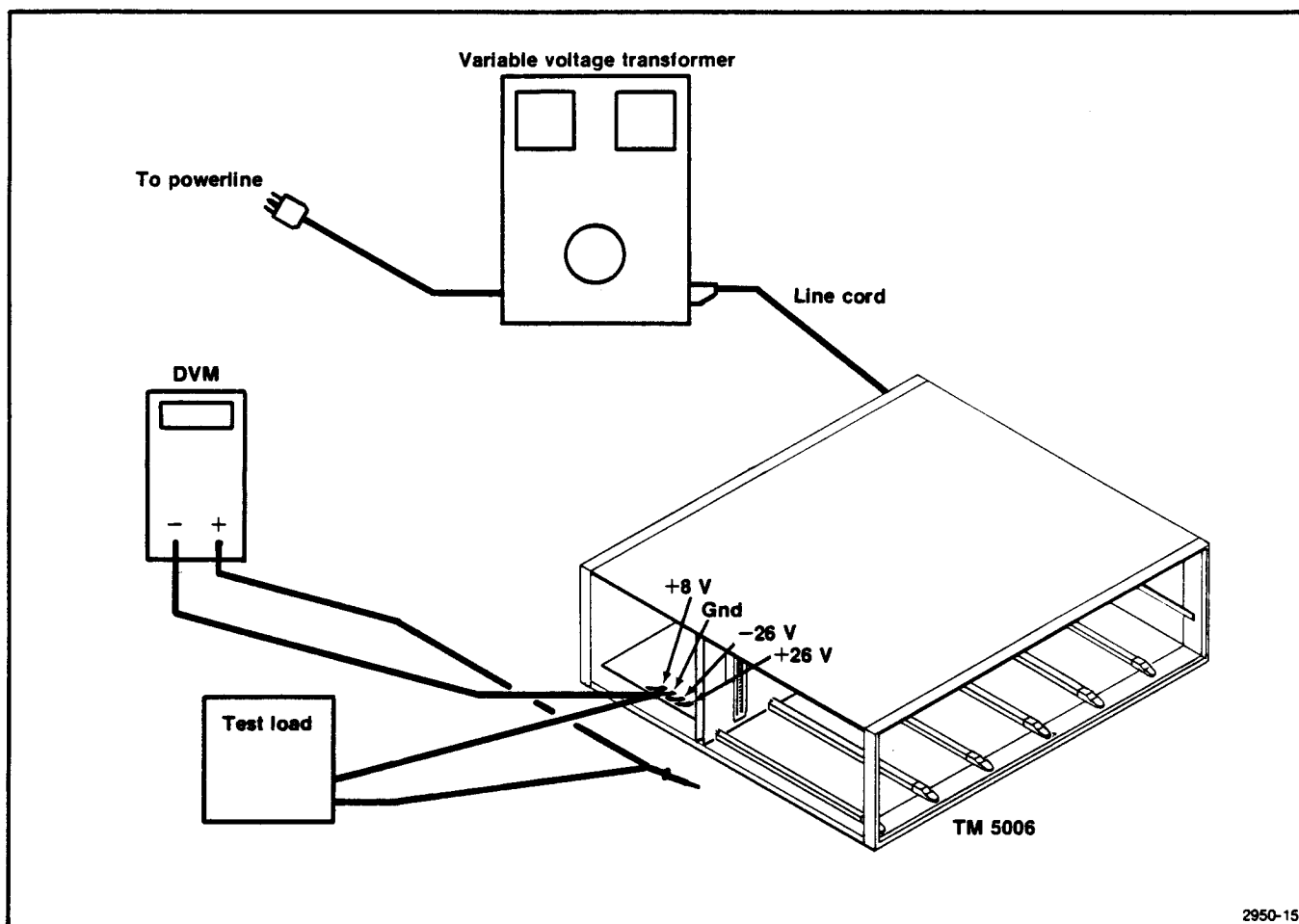

Fig. 4-2. Test setup for performance check steps 1, 2 and 3 and location of connections for adjustment step 1.

- f. CHECK—that the supply reads from +7.6 V to +8.5 V.
- g. Remove all connections.
- h. This completes the Performance Check Procedure.

INTERNAL ADJUSTMENT PROCEDURE

Introduction

This procedure should be performed if the instrument fails to meet the performance requirements of the electrical characteristics listed in the Specification section of this manual. To ensure continued instrument accuracy, it is recommended that adjustment be performed every 1000 hours of operation or every 6 months if used infrequently. Adjustment is also recommended following instrument repair or modification. Adjustments must be made in an ambient temperature of +20°C to +30°C.

Services Available

Tektronix, Inc. provides complete instrument repair and adjustment at local field service centers and at the factory service center. Contact your local Tektronix field office or representative for further information.

Test Equipment Required

Test equipment (or equivalent) listed in Table 4-1 is required for adjustment of the TM 5006. Specifications given for the test equipment are the minimum necessary for accurate adjustment. All test equipment is assumed to be correctly calibrated and operating within specification. If other test equipment is substituted, the calibration setup may need to be altered to meet the requirements of the equipment used.

Adjustment Access

Remove the top and lift side covers to gain access to the +8 V buses, ground buses and the adjustments. Figure 4-4 shows the adjustment locations.

Power Limit Adjustment

The Pwr Lim adjustment, R2060, is used for troubleshooting only. Before beginning calibration make certain this adjustment is fully cw.

1. Adjust 8 V Adj

- Connect the dvm to the +8 V and Gnd terminals as shown in Fig. 4-2. The voltage bus location is shown in Fig. 4-5.
- Set the line voltage to nominal for the selected range.
- CHECK—for a reading of 8.2 V.
- ADJUST—R2151, 8 V Adj for a dvm reading of 8.2 V.

2. Adjust clock Oscillator (SN B021520 and above)

- Set the line voltage to 88% of the nominal value for the selected range.
- Connect a frequency counter to pin 1, U1950.
- ADJUST—R1855 for a reading of 20 kHz on the counter.
- Connect a load as described in Fig. 4-3 from +8V to ground.
- Connect a load as described in Fig. 4-3 from +26V to ground.
- Connect a load as described in Fig. 4-3 from -26V to ground.

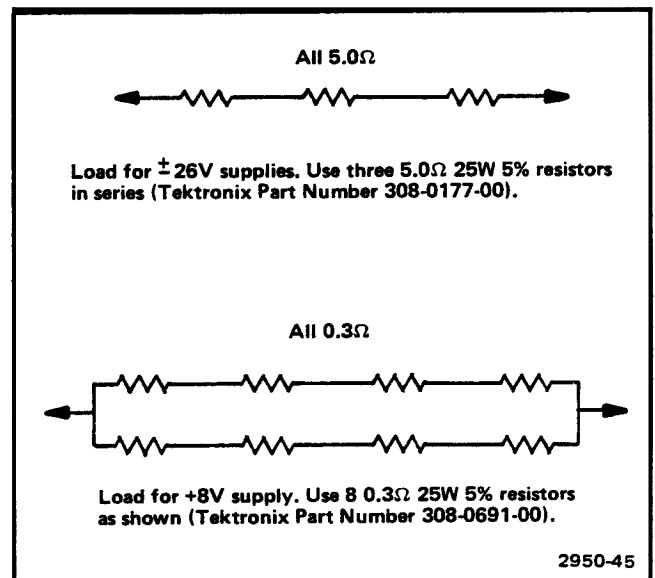

Fig. 4-3. Loads for use in internal adjustment procedure.

- ADJUST—R1855 slowly cw until the dvm reading just begins to decrease. Note the frequency reading on the counter.
- ADJUST—R1855 ccw for a counter reading 0.25 kHz lower than the reading noted above.
- Remove all connections.

This completes the internal adjustment procedure.

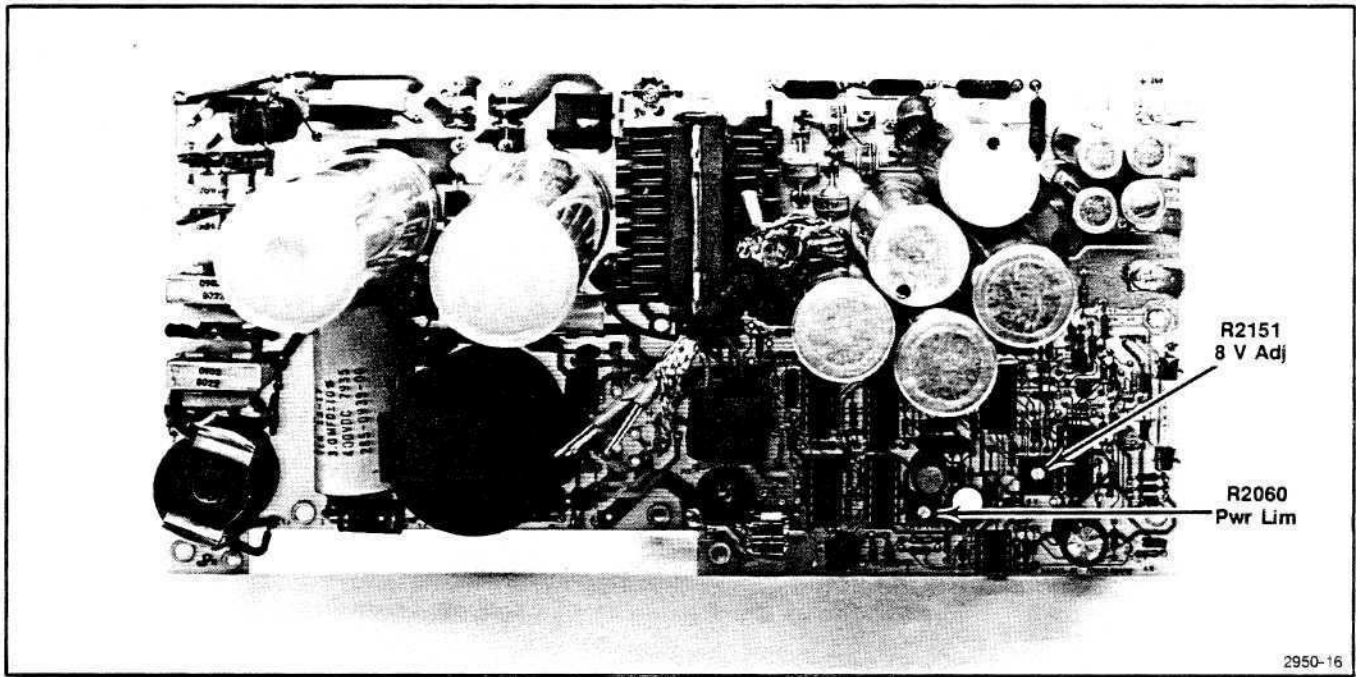

Fig. 4-4. Adjustment location illustration.

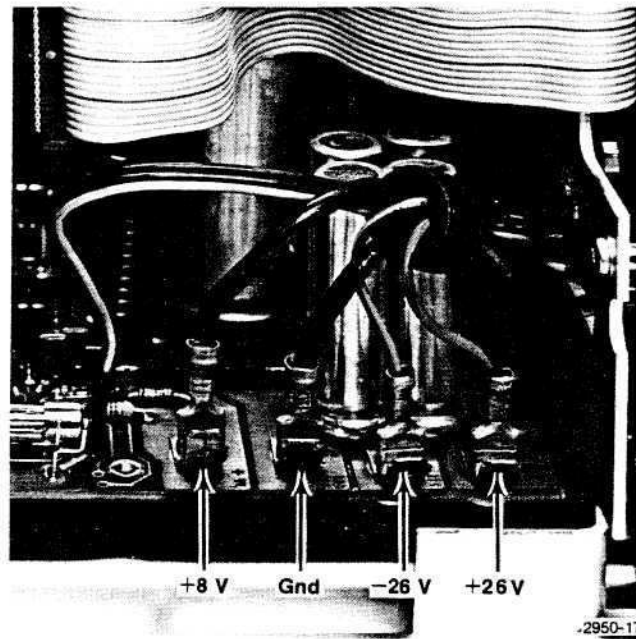

Fig. 4-5. Location of voltage buses.

MAINTENANCE

Line Voltage Selection

Figure 5-1 illustrates the line cord options available for the TM 5006. Fuse data is printed on the rear panel and in the Specification section of this manual. After determining the nominal line voltage, refer to Fig. 5-2 for proper jumper positions. Select the line voltage closest to the nominal for the range used.

Static Sensitive Components

CAUTION

Static discharge can damage any semiconductor component in this instrument.

This instrument contains electrical components that are susceptible to damage from static discharge. See Table 5-1 for relative susceptibility of various classes of semiconductors. Static voltages of 1 kV to 30 kV are common in unprotected environments.

Observe the following precautions to avoid damage:

1. Minimize handling of static-sensitive components.
2. Transport and store static-sensitive components or assemblies in their original containers, on a metal rail, or on conductive foam. Label any package that contains static-sensitive assemblies or components.
3. Discharge the static voltage from your body by wearing a wrist strap while handling these components. Servicing static-sensitive assemblies or components should be performed only at a static-free work station by qualified service personnel.
4. Nothing capable of generating or holding a static charge should be allowed on the work station surface.
5. Keep the component leads shorted together whenever possible.
6. Pick up components by the body, never by the leads.
7. Do not slide the components over any surface.
8. Avoid handling components in areas that have a floor or work surface covering capable of generating a static charge.
9. Use a soldering iron that is connected to earth ground.
10. Use only special antistatic suction type or wick type desoldering tools.

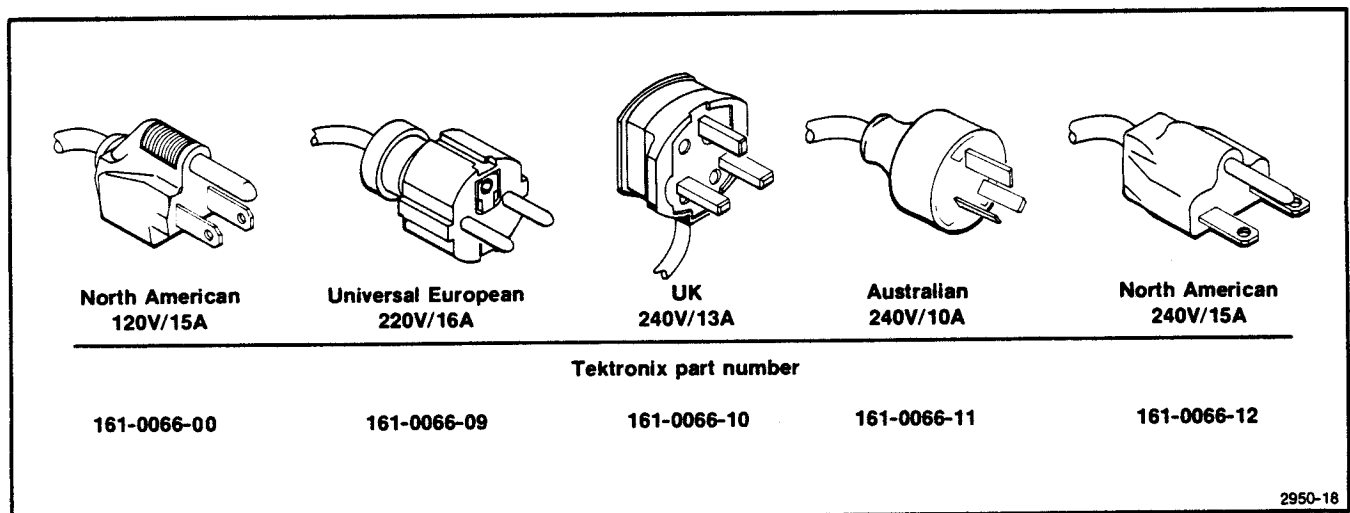

Fig. 5-1. Line cord options for the TM 5006.

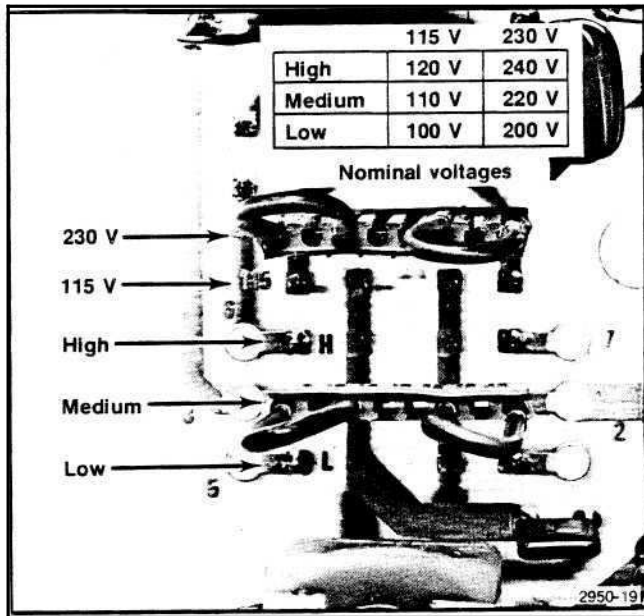

Fig. 5-2. Line voltage jumper positions.

Table 5-1
RELATIVE SUSCEPTIBILITY TO
STATIC DISCHARGE DAMAGE

Semiconductor Classes	Relative Susceptibility Levels ^a
MOS or CMOS microcircuits or discretes, or linear microcircuits with MOS inputs (Most Sensitive)	1
ECL	2
Schottky signal diodes	3
Schottky TTL	4
High-frequency bipolar transistors	5
JFETs	6
Linear microcircuits	7
Low-power Schottky TTL	8
TTL (Least Sensitive)	9

^a Voltage equivalent for levels:

1 = 100 to 500 V	4 = 500 V	7 = 400 to 1000 V (est.)
2 = 200 to 500 V	5 = 400 to 600 V	8 = 900 V
3 = 250 V	6 = 600 to 800 V	9 = 1200 V

(Voltage discharged from a 100 pF capacitor through a resistance of 100 ohms.)

Cleaning

This instrument should be cleaned as often as operating conditions require. Loose dust accumulated on the outside of the instrument can be removed with a soft cloth or small brush. Remove dirt that remains with a soft cloth dampened in a mild detergent and water solution. Do not use abrasive cleaners.

The best way to clean the interior is to blow off the accumulated dust with dry, low-velocity air (approximately 5 lb/in²) or use a soft brush or cloth dampened with a mild detergent and water solution.



Circuit boards and components must be dry before applying power.

Obtaining Replacement Parts

Electrical and mechanical parts can be obtained through your local Tektronix Field Office or representative. However, it may be possible to obtain many of the standard electronic components from a local commercial source. Before purchasing or ordering a part from a source other than Tektronix, Inc., check the Replaceable Electrical Parts list for the proper value, rating, tolerance, and description.

NOTE

When selecting replacement parts, remember that the physical size and shape of a component may affect its performance in the instrument.

Some parts are manufactured or selected by Tektronix, Inc. to satisfy particular requirements or are manufactured for Tektronix, Inc. to our specifications. Most of the mechanical parts used in this instrument have been manufactured by Tektronix, Inc. To determine the manufacturer, refer to the Replaceable Parts list and the cross reference index, Mfr. Code Number to Manufacturer.

When ordering replacement parts from Tektronix, Inc., include the following information:

1. Instrument type and option number.

2. Instrument serial number.

3. A description of the part (if electrical, include complete circuit number).

4. Tektronix part number.

Soldering Techniques

WARNING

To avoid electric shock hazard, disconnect the instrument from the power source before soldering.

The reliability and accuracy of this instrument can be maintained only if proper soldering techniques are used when repairing or replacing parts. General soldering techniques which apply to maintenance of any precision electronic equipment should be used when working on this instrument. Use only 60/40 rosin-core, electronic grade solder. The choice of soldering iron is determined by the repair to be made.

When soldering on circuit boards or small wiring, use only a 15 watt, pencil type soldering iron. A higher wattage soldering iron can cause the etched circuit wiring to separate from the board base material and melt the insulation from small wiring. Always keep the soldering iron tip properly tinned to ensure the best heat transfer to the solder joint. Apply only enough heat to remove the component or to make a good solder joint. To protect heat sensitive components, hold the component lead with a pair of long-nose pliers between the component body and the solder joint. Use a solder removing wick to remove excess solder from connections or to clean circuit board pads.

Semiconductors

To remove in-line integrated circuits use an extracting tool. This tool is available from Tektronix, Inc.; order Tektronix Part No. 003-0619-00. If an extracting tool is not available, use care to avoid damaging the pins. Pull slowly and evenly on both ends of the integrated circuit. Try to avoid disengaging one end before the other end.

Multipin Connectors

The pin connectors used to connect the wires to the interconnecting pins are clamped to the ends of the wires. To replace damaged multi-pin connectors, remove the old pin connector from the holder. Do this by inserting a scribe between the connector and the holder and prying the connector from the holder. Clamp the replacement connector to the wire. Reinstall the connector in the holder.

If the individual end lead pin connectors are removed from the plastic holder, note the order of the individual wires for correct replacement in the holder. For proper replacement see Fig. 5-3.

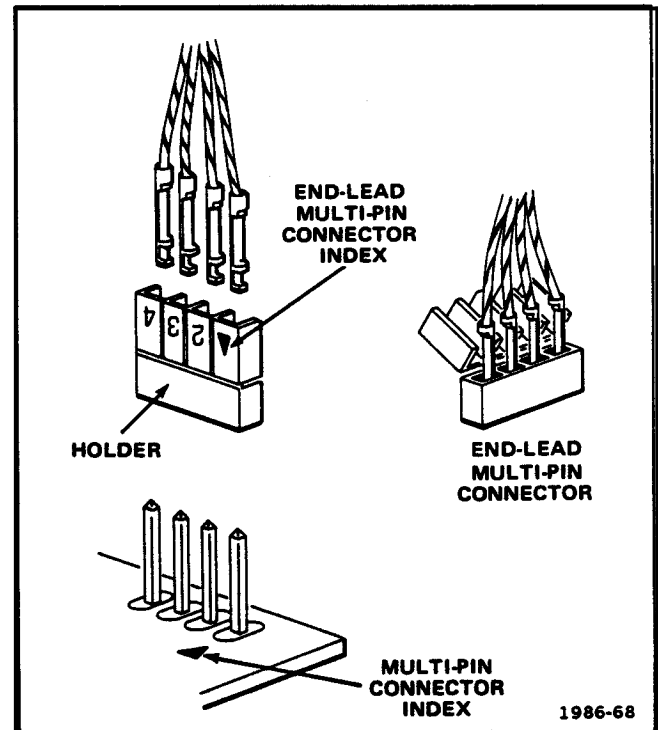

Fig. 5-3. Orientation and disassembly of multipin connector.

Instrument Disassembly

WARNING

Use caution when operating this instrument with the side panels removed as dangerous voltages are present.

To remove the top, bottom and side panels, remove the four screws attaching the feet to the rear of the instrument and slide the panels to the rear. See Fig. 5-4. To remove the interface circuit board, remove the plug-in guide rails and air baffles shown in Fig. 5-5. Next remove the interface circuit board support by removing the screws shown in Fig. 5-6 and Fig. 5-10. Before removing the main interface circuit board, make certain the connections to the board are either unplugged or unsoldered. Remove the six screws holding the board to the mainframe. See Fig. 5-7. To remove the rear panel, remove the screws shown in Fig. 5-8. After these screws are removed, the rear panel may be laid back for easier access to the dc power supply board. After removing the rear panel, the dc power supply circuit board may be removed. Remove the seven screws shown in Fig. 5-9.

WARNING

Dangerous voltages may be present on the filter capacitors on the dc power supply board for several minutes after line voltage removal.

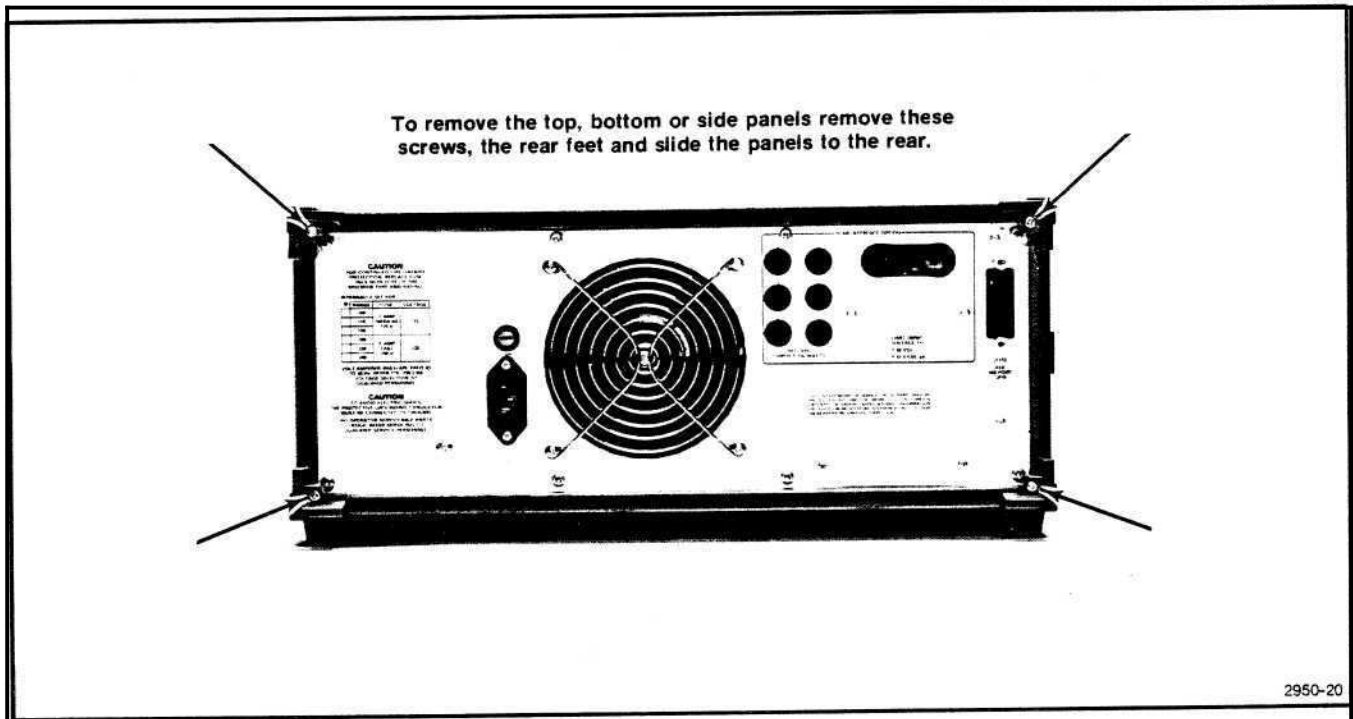

Fig. 5-4. Outer panel removal.

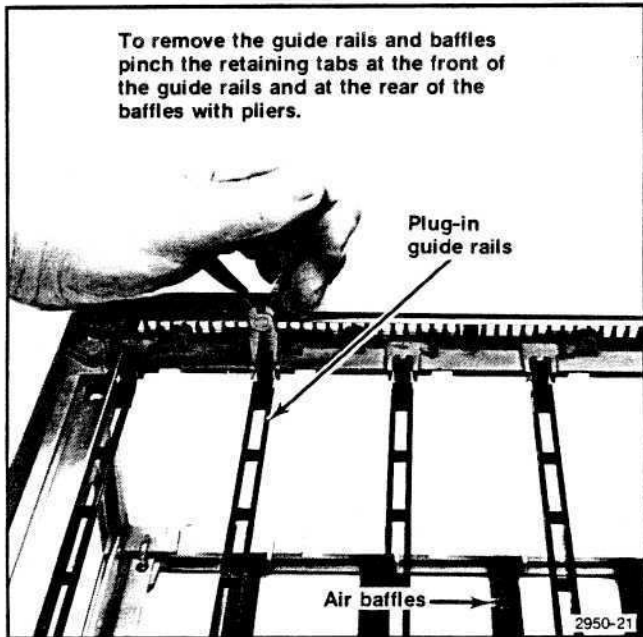

Fig. 5-5. Guide rail and air baffle removal.

To gain access to the bottom of the dc power supply boards, remove the screws as shown in Fig. 5-10. To remove the heat sink first unsolder the wires to the high power series-pass transistors, as shown in Fig. 5-11. Unplug the wires to the series-pass transistors mounted on the heat sink. The circuit numbers for the series-pass transistors are shown in Fig. 5-12. When reinstalling the connections to the series-pass transistors, make certain the connections are correct. The screws holding the heat sink to the circuit board are shown in Fig. 5-13. The heat sink can be removed from the circuit board by removing the four screws attaching the sink to the circuit board, two screws through the fan housing, and disconnecting any remaining wires.

To remove the transformer assembly, remove the screws as shown in Figs. 5-10 and 5-14.

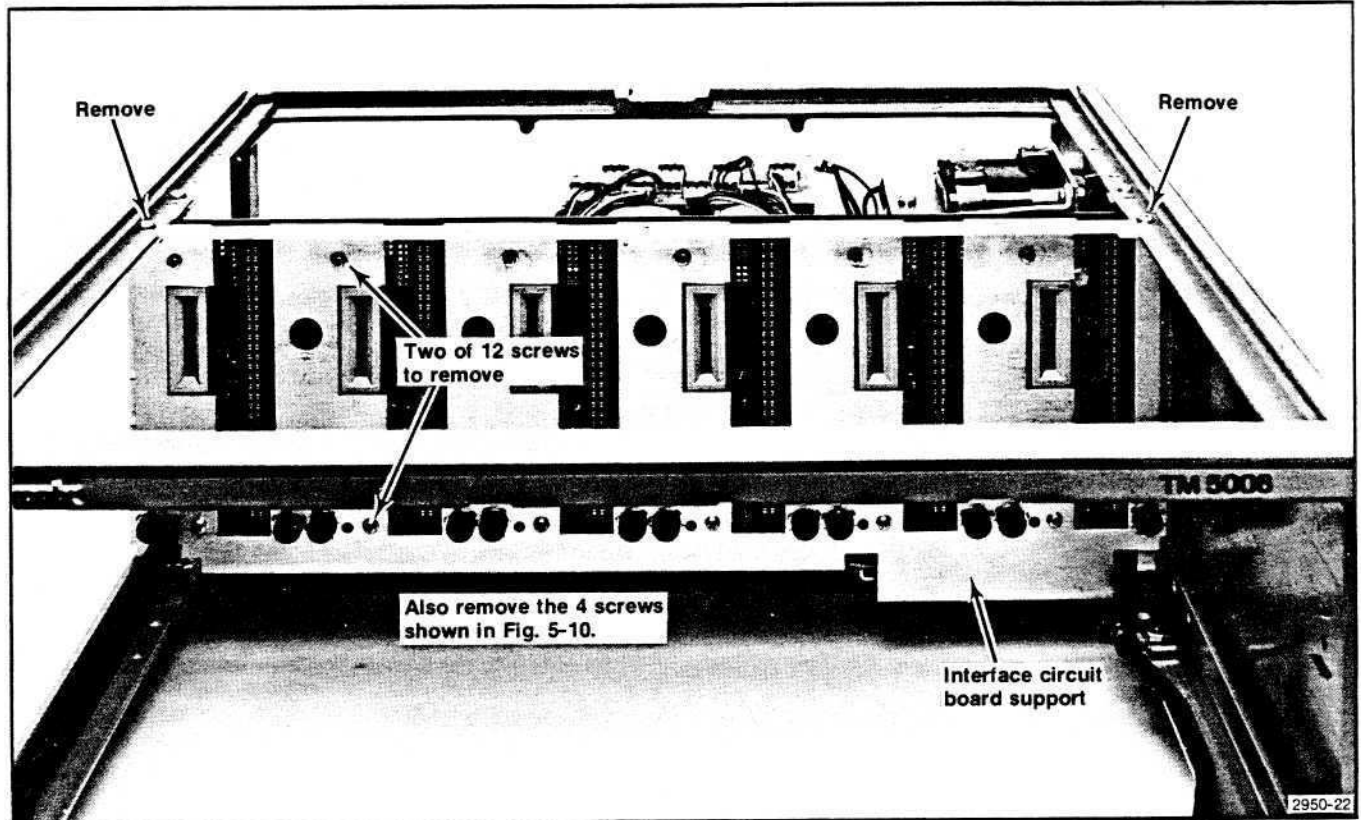

Fig. 5-6. Removal of interface circuit board support.

Circuit Troubleshooting

To help locate a fault in the dc power supply, first disconnect P2330. The location of this plug on the interface board may be determined from the parts location grids located in the pullout pages at the rear of this manual. Make certain the line selector is properly set. Connect the power module to a variable voltage transformer. Slowly apply line voltage to the power module. Observe the indicator lamp DS1600. The location of this lamp may be determined from the parts location grids, also. If the lamp flashes at a regular rate, the high voltage (≈ 300 Vdc) supply is probably operating properly. Turn off the line power. Turn the Pwr Lim (R2060) fully

ccw. The location of this control is shown in the parts location grid. Replace P2330. Connect a dvm across the 8 V bus. Apply ac line power at the nominal line voltage to the power module. Slowly turn the Pwr Lim control R2060 cw and observe the dvm reading. The dvm should read from about 7.5 V to about 8.5 V when R2060 is fully cw. Next adjust the +8 V Adj, R2151, for exactly 8.20 V at no load with nominal line voltage. Next, check the voltage across R1860, the current sense resistor. This should be from about 0.2 V to about 0.4 V. Verify the current limit by shorting out any of the voltage buses and noting the recovery of the supply after about a 3 second delay. Check the +26 V outputs for limits within specification.



Digitally signed by
<http://www.aa4df.com>

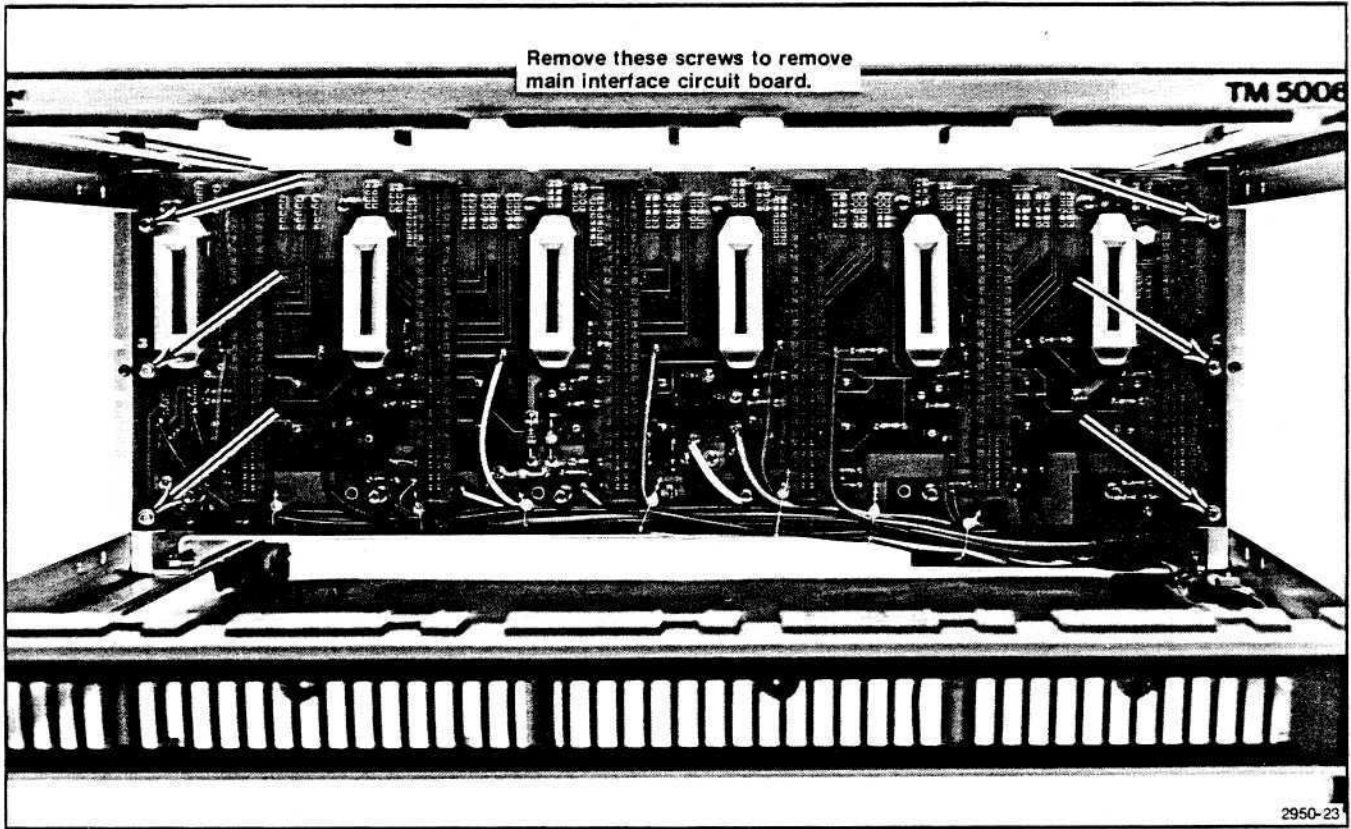

Fig. 5-7. Main interface circuit board removal.

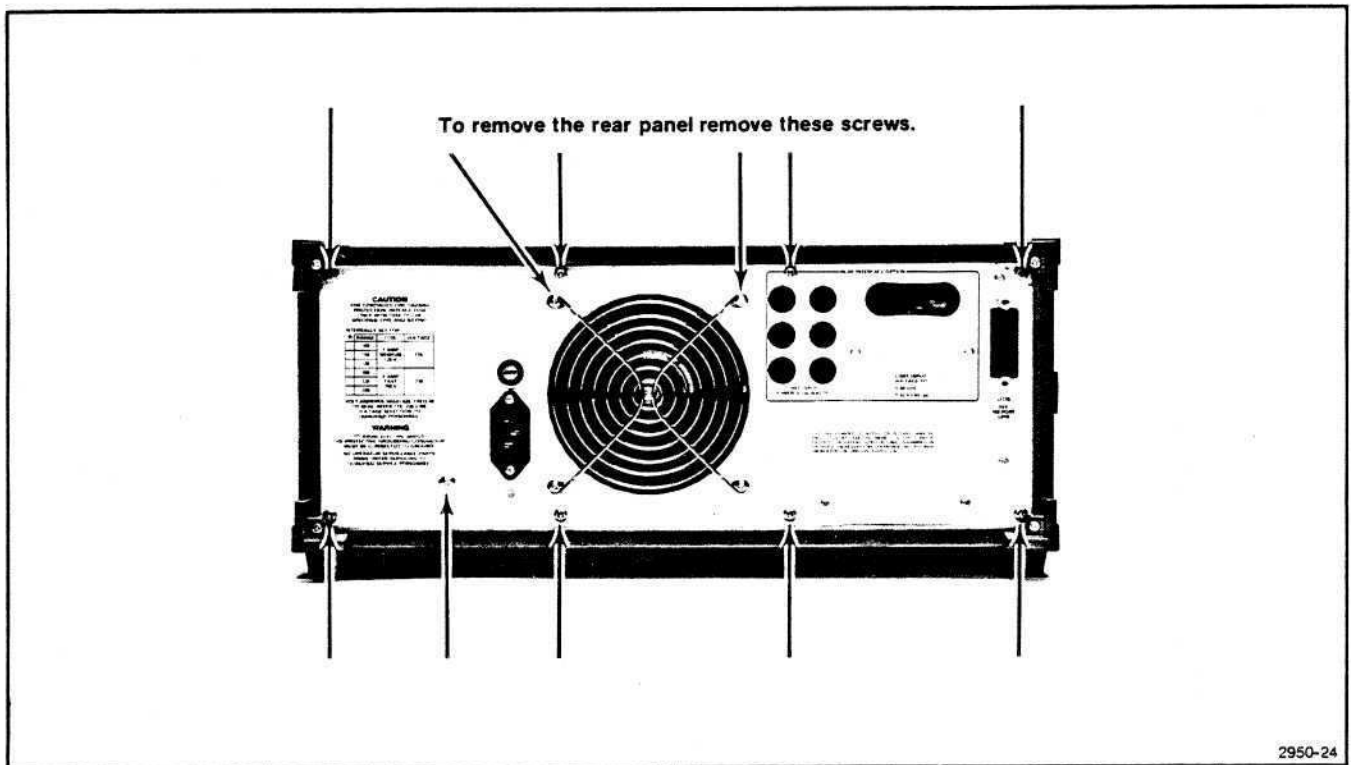
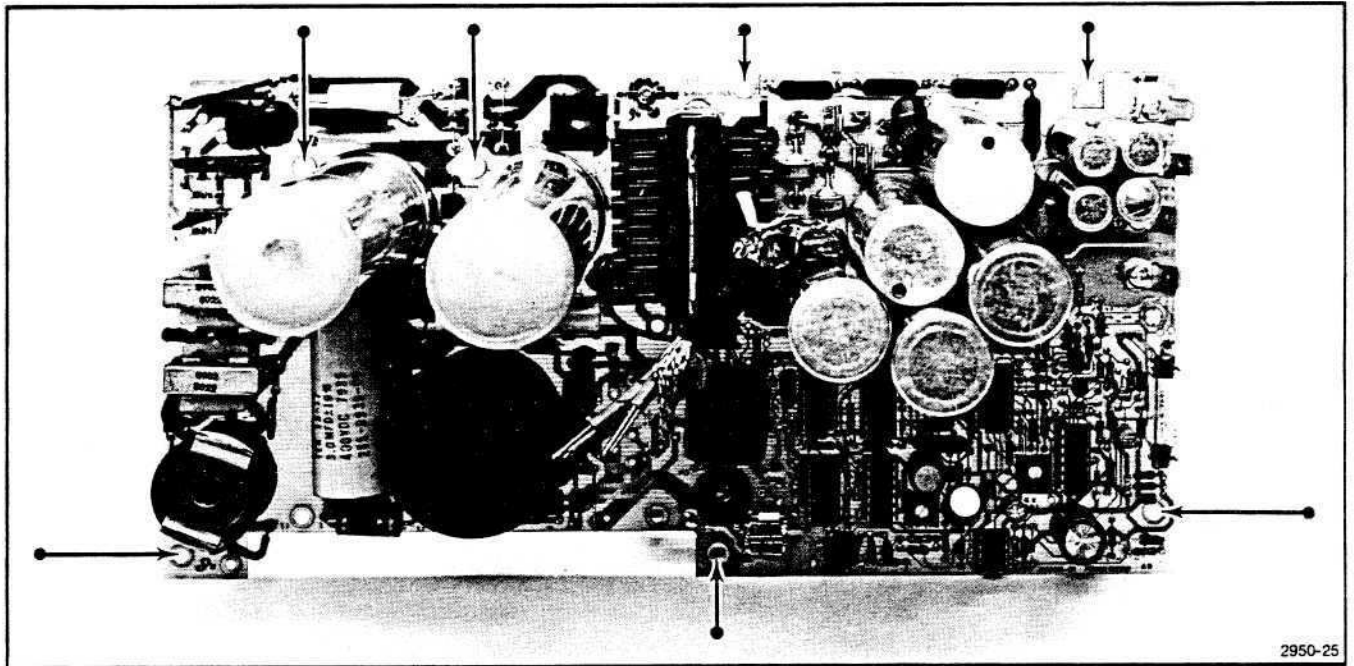
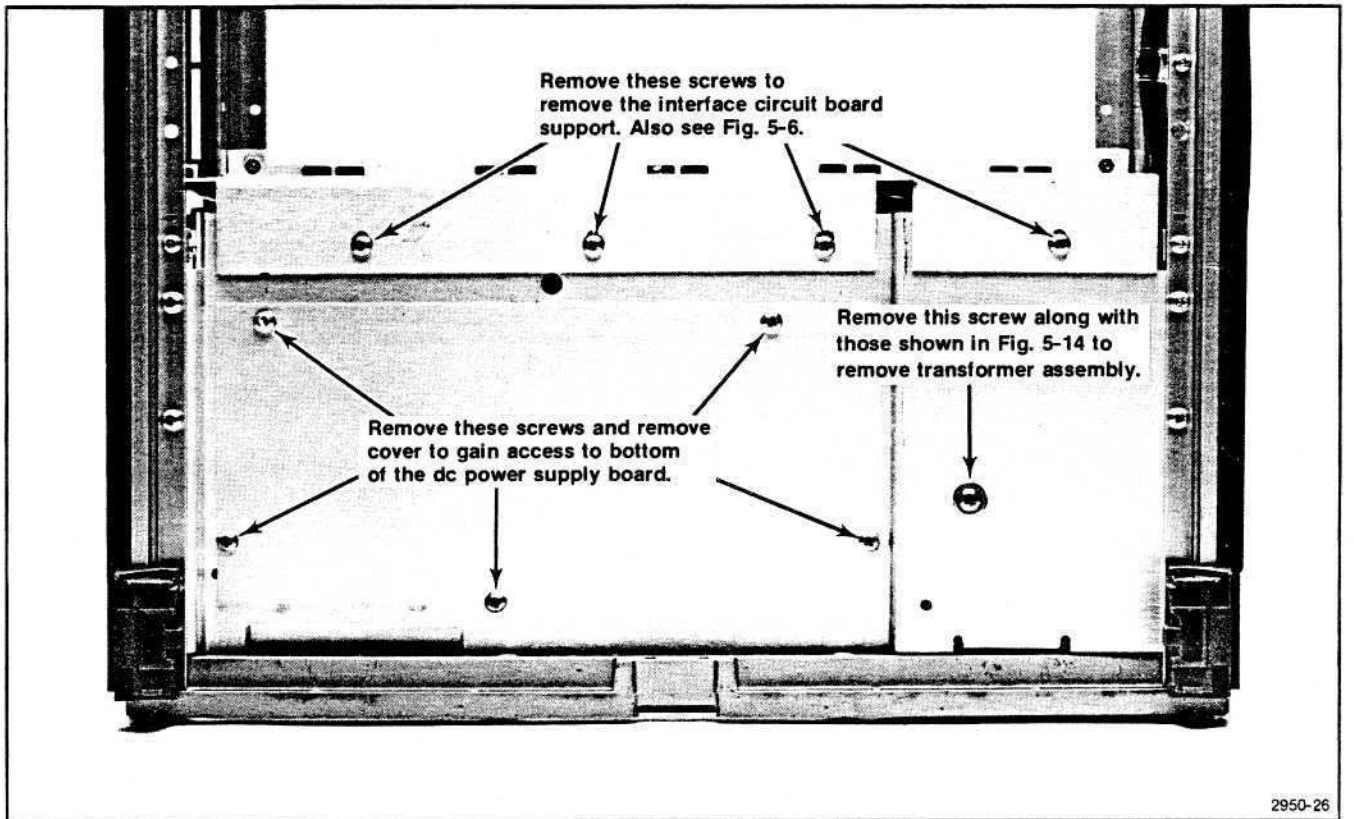

Fig. 5-8. Rear panel removal.



2950-25

Fig. 5-9. Location of screws holding the dc power supply circuit board to the mainframe chassis.



2950-26

Fig. 5-10. Attaching screws on bottom of mainframe.

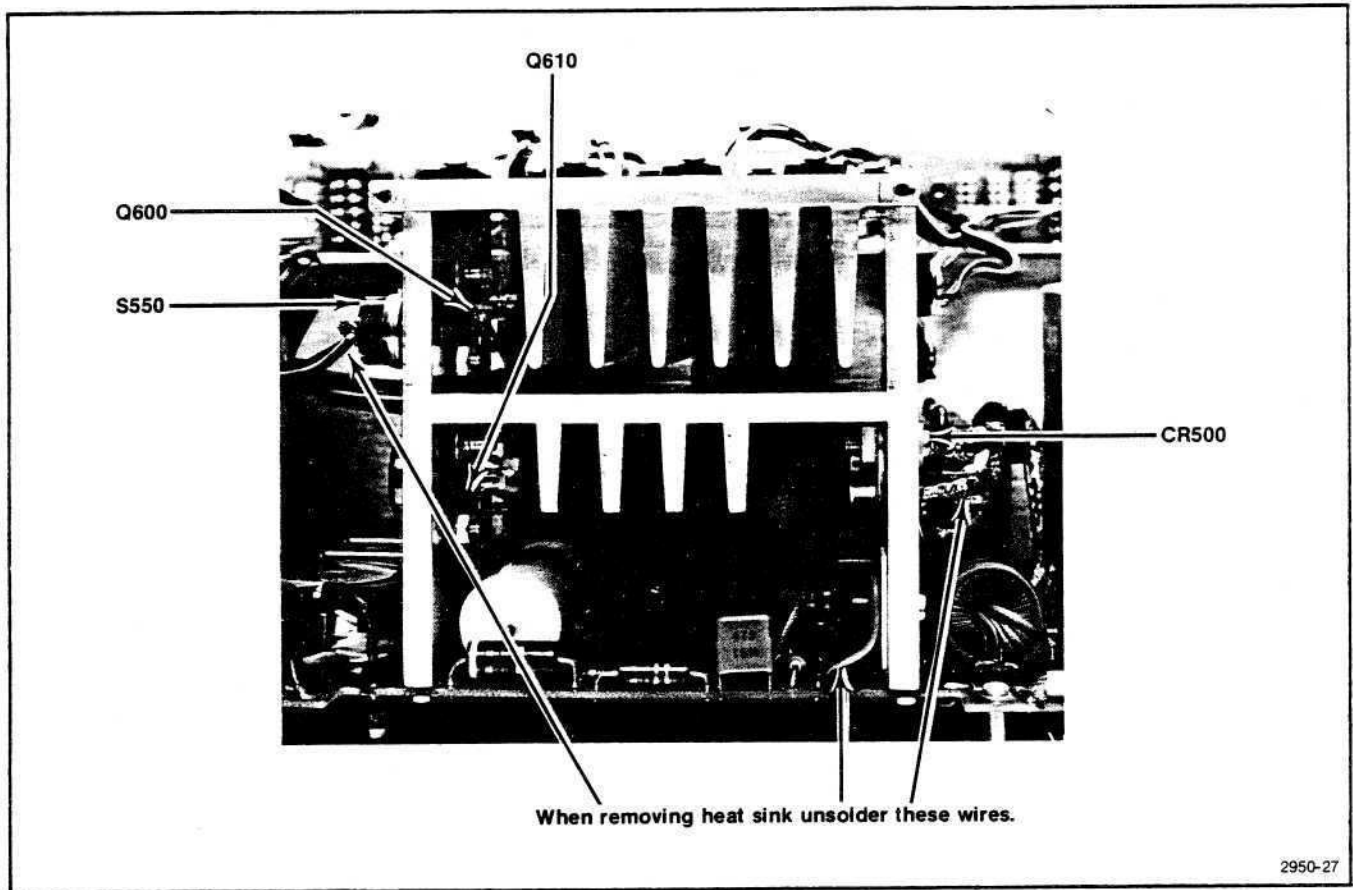

Fig. 5-11. Unsolder these wires to remove heat sink.

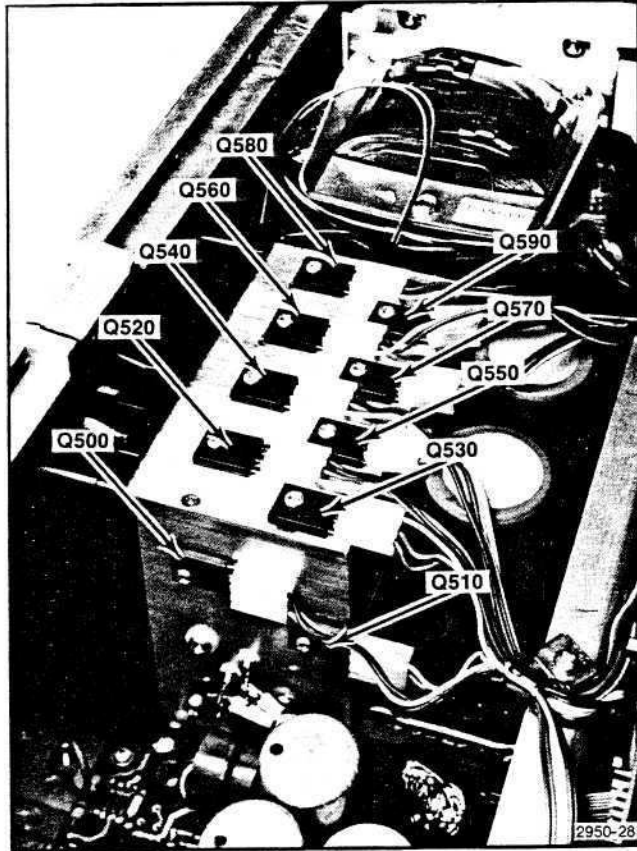

Fig. 5-12. Series pass transistor locations. The high power compartment series pass transistors Q600 and Q610 are on the right side of the heat sink. Q600 is the upper transistor.

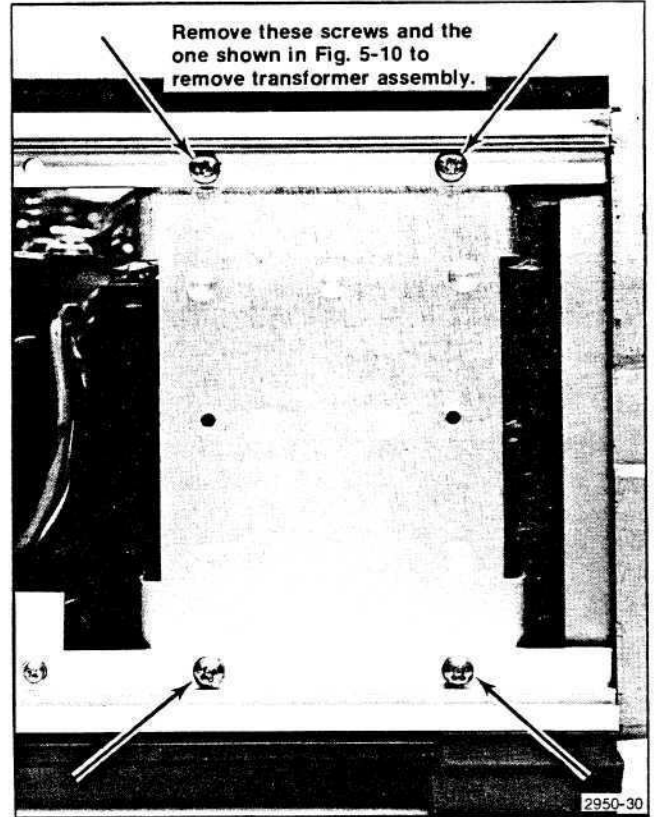

Fig. 5-14. Transformer assembly attaching screws.

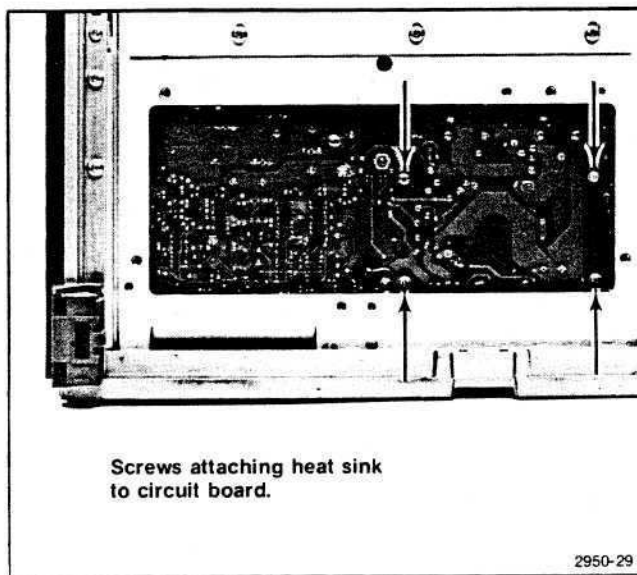

Fig. 5-13. Screws holding heat sink to circuit board.

REAR INTERFACE INFORMATION

PWR Indicator

A signal out on pin 6B on the rear interface connector provides the plug-ins with power supply status information. See Fig. 5-15. This signal is TTL compatible with $\leq 30 \Omega$ output impedance. The maximum plug-in load per compartment is one standard TTL load. No pull-up resistors are allowed. The maximum capacitance per compartment must not exceed 150 pF. The fall and rise time (t_f and t_r) is $\leq 20 \mu\text{s}$.

Pin Assignments

Figure 5-16 shows the pin assignments for the power module outputs. Pins 14 through 28 are reserved for signal connections. See Sections 2 and 6 of this manual and the plug-in manuals for further information.

Figure 5-17 shows the pin assignments for the GPIB rear panel connector.

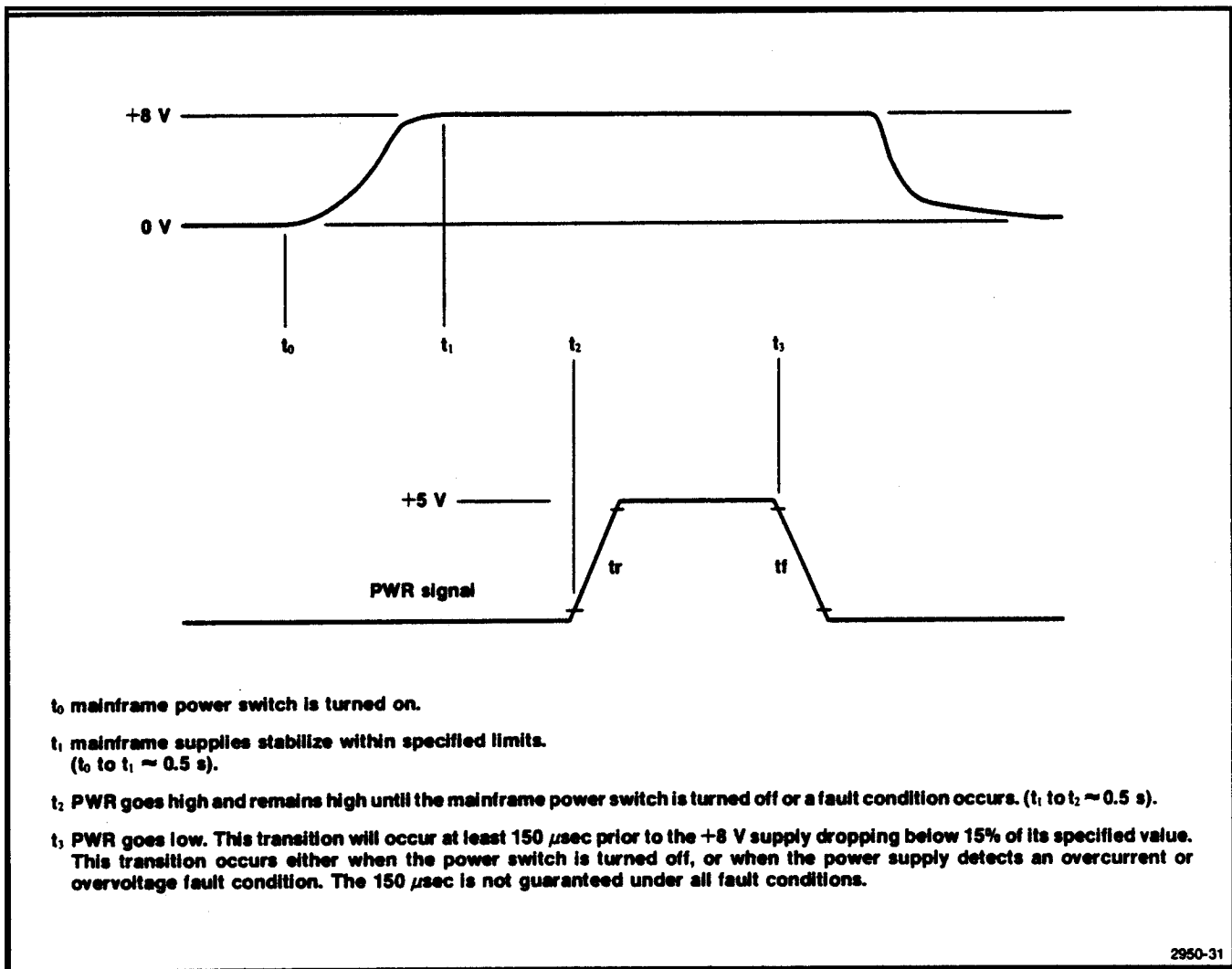

Fig. 5-15. PWR signal timing diagram.

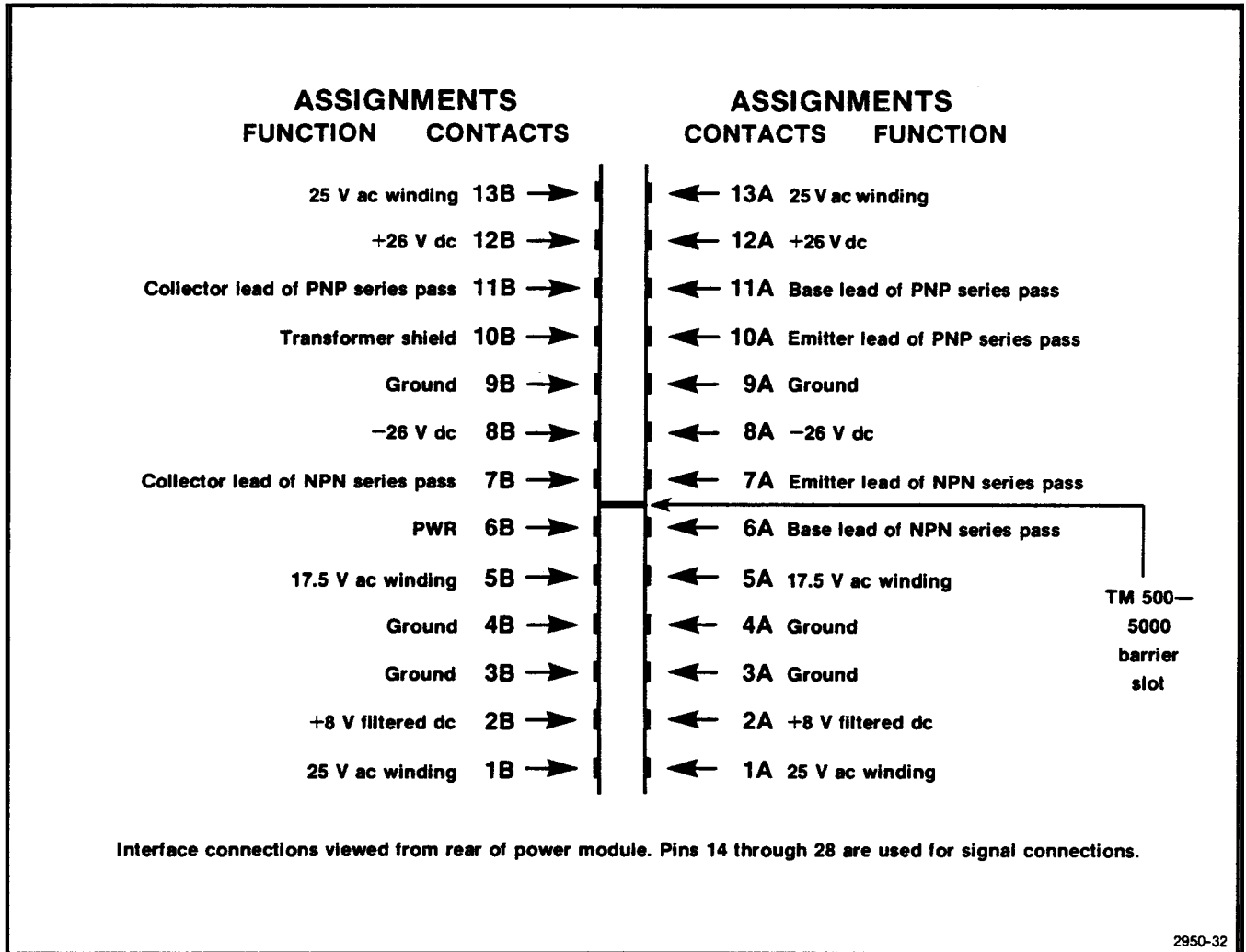

Fig. 5-16. Rear interface connector assignments.

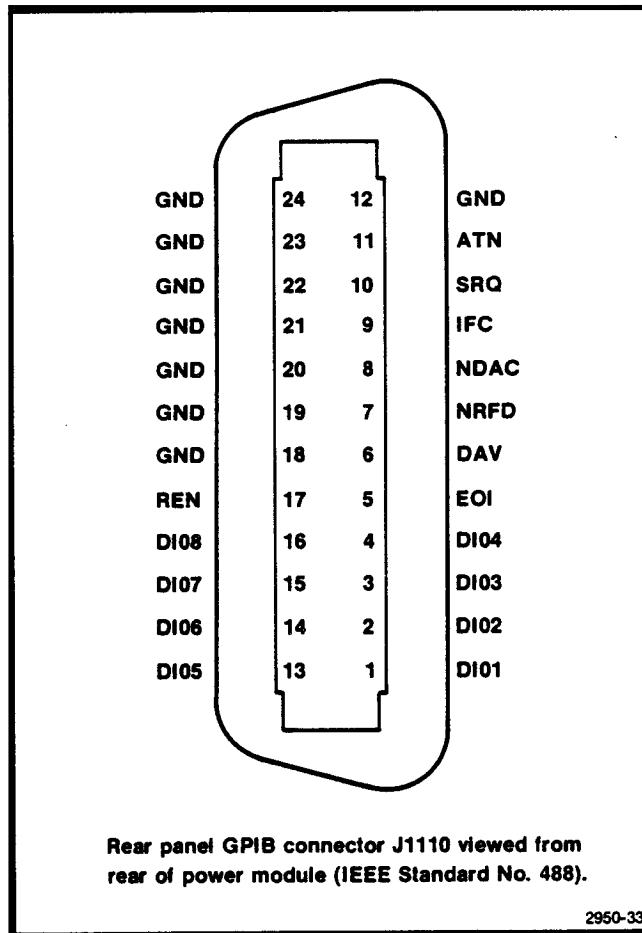

Fig. 5-17. Rear panel GPIB connector J1110 viewed from rear of power module (IEEE Standard No. 488).

OPTIONS

Introduction

Option 02 provides rear interface connections at the rear panel and Option 10 provides rack mounting capabilities. Information on Option 02 is found below as well as included in the kit. Information on Option 10 is provided in Section 2 of this manual as well as with the rackmount kit available from Tektronix, Inc.

Option 02

This factory installed option adds 25-mil square pin connectors to the rear of the interconnecting jacks at all pins from 14A and B to pins 28A and B. This option also adds six bnc connectors and one 50-pin connector to the rear panel. These connectors are not prewired in order to give as much flexibility as possible. Prepared jumpers, coaxial cables, and interconnection jack barriers are included in the kit.

System Design Directions

1. Plan the plug-in location in the mainframe based on operator convenience as well as interface connections.
2. Plan the wiring between interconnecting jacks and to the rear panel connectors before starting assembly. A mating rear panel 50-pin connector and cover are provided for external cabling.

NOTE

There are no pin assignments for the rear panel connectors, due to the great variety of possible connections.

When high frequency or fast digital signals are involved, plan the wiring to minimize crosstalk. Make allowance for possible auxiliary ground connections.

The 50-pin rear panel connector may be easier to connect if it is removed from the rear panel and remounted after connections are made. Remove the top rear cabinet piece for ease of access.

If more than 50 pins are needed, an AMP HD-22 series connector with 104 pins may be mounted in the same cut out. It is suggested that these parts be obtained directly from AMP Inc., Harrisburg, PA or their distributors. For further application information, contact Tektronix TM 500 Marketing Group.

3. Pin assignments for individual plug-ins will be found in the appropriate instruction manual.

4. Install an interconnection jack barrier at the appropriate location on the interconnection jack. Refer to operating instructions for keying assignments for family functions.

5. Select and install the wires (hook-up or coaxial cable) following the guidelines in the Wire Use part of these instructions.

6. Wires or cables which may be at large potential differences should be dressed or bundled so as to avoid contact. Keep all interface wiring away from the power module primary line wiring.



Maximum input voltage is ≤ 60 Vdc or ≤ 42.4 Vdc peak-to-peak. Limit input power to ≤ 150 W per connection.

7. There is an empty cut out which will mount the standard IEC digital interface connector. The connector is not supplied with this option.

Wire Use

1. Hook up wire with square pin receptacles on both ends. These may be used for low frequency or dc circuits where impedance levels and crosstalk are not a problem. The wire is supplied for connection between compartments (adjacent or nonadjacent) or between a compartment and the rear panel. For connection to the rear panel, cut to length then tin and solder the end going to the rear panel connector.

2. Coaxial wire with square pin receptacles on both ends. These are used for connections which require shielding or which must maintain a 50 Ω characteristic impedance. The outer conductor should be connected to either chassis ground or circuit ground. Plug-in lines which require coaxial leads usually have a specified

ground pin assignment. If necessary, establish auxiliary ground connections at the appropriate wire ends. The coaxial wire is supplied for connection between compartments (adjacent or nonadjacent) or between a compartment and the rear panel. For connection to the rear panel, cut to length then tin and solder the end going to the rear panel connector.

REPLACEABLE ELECTRICAL PARTS

PARTS ORDERING INFORMATION

Replacement parts are available from or through your local Tektronix, Inc. Field Office or representative.

Changes to Tektronix instruments are sometimes made to accommodate improved components as they become available, and to give you the benefit of the latest circuit improvements developed in our engineering department. It is therefore important, when ordering parts, to include the following information in your order: Part number, instrument type or number, serial number, and modification number if applicable.

If a part you have ordered has been replaced with a new or improved part, your local Tektronix, Inc. Field Office or representative will contact you concerning any change in part number.

Change information, if any, is located at the rear of this manual.

LIST OF ASSEMBLIES

A list of assemblies can be found at the beginning of the Electrical Parts List. The assemblies are listed in numerical order. When the complete component number of a part is known, this list will identify the assembly in which the part is located.

CROSS INDEX-MFR. CODE NUMBER TO MANUFACTURER

The Mfr. Code Number to Manufacturer index for the Electrical Parts List is located immediately after this page. The Cross Index provides codes, names and addresses of manufacturers of components listed in the Electrical Parts List.

ABBREVIATIONS

Abbreviations conform to American National Standard Y1.1.

COMPONENT NUMBER (column one of the Electrical Parts List)

A numbering method has been used to identify assemblies, subassemblies and parts. Examples of this numbering method and typical expansions are illustrated by the following:

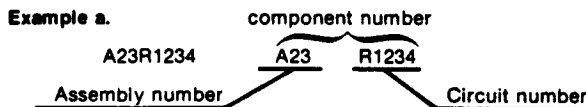

Read: Resistor 1234 of Assembly 23

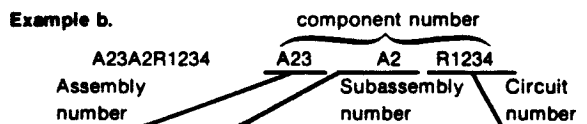

Read: Resistor 1234 of Subassembly 2 of Assembly 23

Only the circuit number will appear on the diagrams and circuit board illustrations. Each diagram and circuit board illustration is clearly marked with the assembly number. Assembly numbers are also marked on the mechanical exploded views located in the Mechanical Parts List. The component number is obtained by adding the assembly number prefix to the circuit number.

The Electrical Parts List is divided and arranged by assemblies in numerical sequence (e.g., assembly A1 with its subassemblies and parts, precedes assembly A2 with its subassemblies and parts).

Chassis-mounted parts have no assembly number prefix and are located at the end of the Electrical Parts List.

TEKTRONIX PART NO. (column two of the Electrical Parts List)

Indicates part number to be used when ordering replacement part from Tektronix.

SERIAL/MODEL NO. (columns three and four of the Electrical Parts List)

Column three (3) indicates the serial number at which the part was first used. Column four (4) indicates the serial number at which the part was removed. No serial number entered indicates part is good for all serial numbers.

NAME & DESCRIPTION (column five of the Electrical Parts List)

In the Parts List, an Item Name is separated from the description by a colon (:). Because of space limitations, an Item Name may sometimes appear as incomplete. For further Item Name identification, the U.S. Federal Cataloging Handbook H6-1 can be utilized where possible.

MFR. CODE (column six of the Electrical Parts List)

Indicates the code number of the actual manufacturer of the part. (Code to name and address cross reference can be found immediately after this page.)

MFR. PART NUMBER (column seven of the Electrical Parts List)

Indicates actual manufacturers part number.

CROSS INDEX - MFR. CODE NUMBER TO MANUFACTURER

Mfr. Code	Manufacturer	Address	City, State, Zip Code
00213	NYTRONICS COMPONENTS GROUP INC SUBSIDIARY OF NYTRONICS INC	ORANGE ST	DARLINGTON SC 29532
00779	AMP INC	P O BOX 3608	HARRISBURG PA 17105
00853	SANGAMO WESTON INC	SANGAMO RD	PICKENS SC 29671
01121	SANGAMO CAPACITOR DIV	P O BOX 128	
01281	ALLEN-BRADLEY CO	1201 SOUTH 2ND ST	MILWAUKEE WI 53204
	TRW INC	14520 AVIATION BLVD	LAWNDALE CA 90260
02735	TRW SEMICONDUCTOR DIV		
	RCA CORP	ROUTE 202	SOMERVILLE NJ 08876
02777	SOLID STATE DIVISION		
03508	HOPKINS ENGINEERING CO	12900 FOOTHILL BLVD	SAN FERNANDO CA 91342
	GENERAL ELECTRIC CO	W GENESEE ST	AUBURN NY 13021
04099	SEMI-CONDUCTOR PRODUCTS DEPT CAPCO INC	FORESIGHT INDUSTRIAL PARK P O BOX 2164	GRAND JUNCTION CO 81501
04222	AVX CERAMICS DIV OF AVX CORP	19TH AVE SOUTH P O BOX 867	MYRTLE BEACH SC 29577
04713	MOTOROLA INC	5005 E MCDOWELL RD	PHOENIX AZ 85008
	SEMICONDUCTOR GROUP		
05347	ULTRONIX INC	461 N 22ND ST	GRAND JUNCTION CO 81501
05397	UNION CARBIDE CORP MATERIALS SYSTEMS DIV	11901 MADISON AVE	CLEVELAND OH 44101
05828	GENERAL INSTRUMENT CORP	600 W JOHN ST	HICKSVILLE NY 11802
	GOVERNMENT SYSTEMS DIV		
07716	TRW INC	2850 MT PLEASANT AVE	BURLINGTON IA 52601
	TRW ELECTRONICS COMPONENTS TRW IRC FIXED RESISTORS/BURLINGTON		
12969	UNITRODE CORP	580 PLEASANT ST	WATERTOWN MA 02172
14193	CAL-R INC	1601 OLYMPIC BLVD	SANTA MONICA CA 90404
14604	ELMWOOD SENSORS INC	1655 ELMWOOD AVENUE	CRANSTON RI 02907
14752	ELECTRO CUBE INC	1710 S DEL MAR AVE	SAN GABRIEL CA 91776
19396	ILLINOIS TOOL WORKS INC	900 FOLLIN LANE S E	VIENNA VA 22180
	PAKTRON DIVISION		
19701	MEPCO/ELECTRA INC	P O BOX 760	MINERAL WELLS TX 76067
	A NORTH AMERICAN PHILIPS CO		
22526	DU PONT E I DE NEMOURS AND CO INC	515 FISHING CREEK RD	NEW CUMBERLAND PA 17070-3007
	DU PONT CONNECTOR SYSTEMS DIV MILITARY PRODUCTS GROUP		
24546	CORNING GLASS WORKS	550 HIGH ST	BRADFORD PA 16701
25088	SIEMENS CORP	186 WOOD AVE S	ISELIN NJ 08830
27014	NATIONAL SEMICONDUCTOR CORP	2900 SEMICONDUCTOR DR	SANTA CLARA CA 95051
31781	EDAC INC	20 RAILSIDE RD	DON MILLS ONT CAN M3A 1A4
32997	BOURNS INC	1200 COLUMBIA AVE	RIVERSIDE CA 92507
	TRIMPOT DIV		
51406	MURATA ERIE NORTH AMERICA INC	1148 FRANKLIN RD SE	MARIETTA GA 30067
	GEORGIA OPERATIONS		
51642	CENTRE ENGINEERING INC	2820 E COLLEGE AVE	STATE COLLEGE PA 16801
54583	TDK ELECTRONICS CORP	755 EASTGATE BLVD	GARDEN CITY NY 11530
55680	NICHICON /AMERICA/ CORP	927 E STATE PKY	SCHAUMBURG IL 60195
56289	SPRAGUE ELECTRIC CO	87 MARSHALL ST	NORTH ADAMS MA 01247
56880	MAGNETICS INC	3218 NOBLE ST	BALTIMORE MD 21224
57668	ROHM CORP	16931 MILLIKEN AVE	IRVINE CA 92713
58224	XENELL CORP	HWY 77 S P O BOX 726	WYNNEWOOD OK 73098
59660	TUSONIX INC	2155 N FORBES BLVD	TUCSON, ARIZONA 85705
60705	CERA-MITE CORPORATION	1327 6TH AVE	GRAFTON WI 53024
71400	BUSSMANN MFG CO	114 OLD STATE RD PO BOX 14460	ST LOUIS MO 63178
	MCGRAW EDISON CO		
75042	INTERNATIONAL RESISTIVE CO INC	401 N BROAD ST	PHILADELPHIA PA 19108
78488	STACKPOLE CARBON CO		ST MARYS PA 15857
80009	TEKTRONIX INC	4900 S W GRIFFITH DR P O BOX 500	BEAVERTON OR 97077
82877	ROTRON INC	7-9 HASBROUCK LANE	WOODSTOCK NY 12498
TK0510	PANASONIC COMPANY	ONE PANASONIC WAY	SECAUCUS NJ 07094
	DIV OF MATSUSHITA ELECTRIC CORP		
TK0935	MARQUARDT SWITCHES INC	MARQUARDT 67 ALBANY ST	CAZENOVIA NY 13035

CROSS INDEX - MFR. CODE NUMBER TO MANUFACTURER

<u>Mfr. Code</u>	<u>Manufacturer</u>	<u>Address</u>	<u>City, State, Zip Code</u>
TK1345	ZMAN AND ASSOCIATES	7633 S 180TH	KENT WA 98032

Replaceable Electrical Parts - TM 5006

Component No.	Tektronix Part No.	Serial/Assembly No. Effective	Dscont	Name & Description	Mfr. Code	Mfr. Part No.
A10	670-6537-00			CIRCUIT BD ASSY:MAIN INTERCONNECT (STANDARD ONLY)	80009	670-6537-00
A10	670-6653-00			CIRCUIT BD ASSY:MAIN INTERCONNECT (OPTION 02,12 ONLY)	80009	670-6653-00
A11	670-6538-00	B010100	B021519	CIRCUIT BD ASSY:POWER SUPPLY	80009	670-6538-00
A11	670-6538-01	B021520	B033969	CIRCUIT BD ASSY:POWER SUPPLY	80009	670-6538-01
A11	670-6538-02	B033970		CIRCUIT BD ASSY:POWER SUPPLY	80009	670-6538-02
A15	670-6991-00	B010100	B020189	CIRCUIT BD ASSY:PASSIVE GPIB INTERCONNECT	80009	670-6991-00
A16	670-7179-00	B020190		CIRCUIT BD ASSY:GPIB INTERFACE	80009	670-7179-00
A10	670-6537-00			CIRCUIT BD ASSY:MAIN INTERCONNECT (STANDARD ONLY)	80009	670-6537-00
A10	670-6653-00			CIRCUIT BD ASSY:MAIN INTERCONNECT (OPTION 02,12 ONLY)	80009	670-6653-00
A10C1010	281-0774-00			CAP,FXD,CER DI:0.022MFD,20%,100V	04222	MA201E223MAA
A10C1011	281-0775-00			CAP,FXD,CER DI:0.1UF,20%,50V	04222	MA205E104MAA
A10C1012	281-0775-00			CAP,FXD,CER DI:0.1UF,20%,50V	04222	MA205E104MAA
A10C1020	281-0775-00			CAP,FXD,CER DI:0.1UF,20%,50V	04222	MA205E104MAA
A10C1021	281-0774-00			CAP,FXD,CER DI:0.022MFD,20%,100V	04222	MA201E223MAA
A10C1110	281-0774-00			CAP,FXD,CER DI:0.022MFD,20%,100V	04222	MA201E223MAA
A10C1111	281-0775-00			CAP,FXD,CER DI:0.1UF,20%,50V	04222	MA205E104MAA
A10C1112	281-0775-00			CAP,FXD,CER DI:0.1UF,20%,50V	04222	MA205E104MAA
A10C1120	281-0775-00			CAP,FXD,CER DI:0.1UF,20%,50V	04222	MA205E104MAA
A10C1121	281-0774-00			CAP,FXD,CER DI:0.022MFD,20%,100V	04222	MA201E223MAA
A10C1210	281-0774-00			CAP,FXD,CER DI:0.022MFD,20%,100V	04222	MA201E223MAA
A10C1211	281-0775-00			CAP,FXD,CER DI:0.1UF,20%,50V	04222	MA205E104MAA
A10C1212	281-0775-00			CAP,FXD,CER DI:0.1UF,20%,50V	04222	MA205E104MAA
A10C1220	281-0775-00			CAP,FXD,CER DI:0.1UF,20%,50V	04222	MA205E104MAA
A10C1221	281-0774-00			CAP,FXD,CER DI:0.022MFD,20%,100V	04222	MA201E223MAA
A10C1222	281-0774-00			CAP,FXD,CER DI:0.022MFD,20%,100V	04222	MA201E223MAA
A10C1223	281-0774-00			CAP,FXD,CER DI:0.022MFD,20%,100V	04222	MA201E223MAA
A10C1310	281-0774-00			CAP,FXD,CER DI:0.022MFD,20%,100V	04222	MA201E223MAA
A10C1311	281-0775-00			CAP,FXD,CER DI:0.1UF,20%,50V	04222	MA205E104MAA
A10C1312	281-0775-00			CAP,FXD,CER DI:0.1UF,20%,50V	04222	MA205E104MAA
A10C1320	281-0775-00			CAP,FXD,CER DI:0.1UF,20%,50V	04222	MA205E104MAA
A10C1321	281-0774-00			CAP,FXD,CER DI:0.022MFD,20%,100V	04222	MA201E223MAA
A10C1410	281-0774-00			CAP,FXD,CER DI:0.022MFD,20%,100V	04222	MA201E223MAA
A10C1411	281-0775-00			CAP,FXD,CER DI:0.1UF,20%,50V	04222	MA205E104MAA
A10C1412	281-0775-00			CAP,FXD,CER DI:0.1UF,20%,50V	04222	MA205E104MAA
A10C1420	281-0775-00			CAP,FXD,CER DI:0.1UF,20%,50V	04222	MA205E104MAA
A10C1421	281-0774-00			CAP,FXD,CER DI:0.022MFD,20%,100V	04222	MA201E223MAA
A10C1510	281-0774-00			CAP,FXD,CER DI:0.022MFD,20%,100V	04222	MA201E223MAA
A10C1511	281-0775-00			CAP,FXD,CER DI:0.1UF,20%,50V	04222	MA205E104MAA
A10C1512	281-0775-00			CAP,FXD,CER DI:0.1UF,20%,50V	04222	MA205E104MAA
A10C1520	281-0775-00			CAP,FXD,CER DI:0.1UF,20%,50V	04222	MA205E104MAA
A10C1521	281-0774-00			CAP,FXD,CER DI:0.022MFD,20%,100V	04222	MA201E223MAA
A10CR1310	152-0198-00			SEMICON DVC,DI:RECT,SI,200V,3A,A249	03508	1N5624
A10CR1311	152-0198-00			SEMICON DVC,DI:RECT,SI,200V,3A,A249	03508	1N5624
A10CR1320	152-0198-00			SEMICON DVC,DI:RECT,SI,200V,3A,A249	03508	1N5624
A10E500	276-0599-00			CORE,EM:TOROID,FERRITE	78488	57-1540
A10J1000	131-1078-00			CONN,RCPT,ELEC:CKT BD,28/56 CONTACT	31781	303-056-520-301
A10J1100	131-1078-00			CONN,RCPT,ELEC:CKT BD,28/56 CONTACT	31781	303-056-520-301
A10J1200	131-1078-00			CONN,RCPT,ELEC:CKT BD,28/56 CONTACT	31781	303-056-520-301
A10J1300	131-1078-00			CONN,RCPT,ELEC:CKT BD,28/56 CONTACT	31781	303-056-520-301
A10J1400	131-1078-00			CONN,RCPT,ELEC:CKT BD,28/56 CONTACT	31781	303-056-520-301
A10J1500	131-1078-00			CONN,RCPT,ELEC:CKT BD,28/56 CONTACT	31781	303-056-520-301
A10J1520	131-0608-00			TERMINAL,PIN:0.365 L X 0.025 BRZ GLD PL (QTY 3)	22526	48283-036

Component No.	Tektronix		Serial/Assembly No.		Name & Description	Mfr. Code	Mfr. Part No.
	Part No.	Effective	Discort				
A10J1530	131-0608-00				TERMINAL, PIN: 0.365 L X 0.025 BRZ GLD PL (QTY 3)	22526	48283-036
A10Q1525	151-0462-00				TRANSISTOR: PNP, SI, T0-220	04713	SJE491
A10R1120	315-0100-00				RES, FXD, FILM: 10 OHM, 5%, 0.25W	19701	5043CX10RR00J
A10R1523	308-0142-00				RES, FXD, WW: 30 OHM, 5%, 3W	00213	1240S-30-5
A10R1526	315-0332-00				RES, FXD, FILM: 3.3K OHM, 5%, 0.25W	57668	NTR25J-E03K3
A10R1527	308-0740-00				RES, FXD, WW: 20 OHM, 1%, 3W	00213	1200S-20-1
A11	670-6538-00	B010100	B021519		CIRCUIT BD ASSY: POWER SUPPLY	80009	670-6538-00
A11	670-6538-01	B021520	B033969		CIRCUIT BD ASSY: POWER SUPPLY	80009	670-6538-01
A11	670-6538-02	B033970			CIRCUIT BD ASSY: POWER SUPPLY	80009	670-6538-02
A11C1120	283-0280-00				CAP, FXD, CER DI: 2200PF, 10%, 2000V	60705	564CBA202EH222
A11C1121	283-0417-00	B010100	B033969		CAP, FXD, CER DI: 0.22UF, 20%, 400V	51642	500-400-Z5U-224M
A11C1121	285-1218-00	B033970			CAP, FXD, PLASTIC: 0.27UF, 10%, 400VDC	04099	MMW274410
A11C1140	283-0280-00				CAP, FXD, CER DI: 2200PF, 10%, 2000V	60705	564CBA202EH222
A11C1200	285-1218-00				CAP, FXD, PLASTIC: 0.27UF, 10%, 400VDC	04099	MMW274410
A11C1210	290-0878-00				CAP, FXD, ELCTLT: 1100UF, -10+75%, 200 V	56289	68D11005
A11C1240	285-0939-00				CAP, FXD, PLASTIC: 3UF, 5%, 400V	04099	TEK13-17
A11C1330	283-0044-00				CAP, FXD, CER DI: 1000PF, 20%, 3000V	51406	DHA12Y5S102M3KV
A11C1430	285-1205-00				CAP, FXD, MTLZD: 0.06UF, 5%, 1000V	14752	C-2658
A11C1450	283-0000-00				CAP, FXD, CER DI: 0.001UF, +100-0%, 500V	59660	831-610-Y5U0102P
A11C1510	290-0878-00				CAP, FXD, ELCTLT: 1100UF, -10+75%, 200 V	56289	68D11005
A11C1530	283-0194-00				CAP, FXD, CER DI: 4.7UF, 20%, 50V	04222	SR505E475MAA
A11C1550	283-0187-00				CAP, FXD, CER DI: 0.047UF, 10%, 400V	04222	SR308C473KAA
A11C1560	283-0194-00				CAP, FXD, CER DI: 4.7UF, 20%, 50V	04222	SR505E475MAA
A11C1600	283-0178-00				CAP, FXD, CER DI: 0.1UF, 20%, 100V	05397	C330C104Z1U1CA
A11C1620	283-0000-00				CAP, FXD, CER DI: 0.001UF, +100-0%, 500V	59660	831-610-Y5U0102P
A11C1720	283-0178-00				CAP, FXD, CER DI: 0.1UF, 20%, 100V	05397	C330C104Z1U1CA
A11C1840	283-0680-00				CAP, FXD, MICA DI: 330PF, 1%, 500V	00853	D155F331F0
A11C1910	290-0900-00				CAP, FXD, ELCTLT: 1600UF, +100-10%, 50V	56289	674D168H050JP5A
A11C1920	290-0930-00				CAP, FXD, ELCTLT: 11000UF, +100-10%, 12V	56289	674D119H012JS5A
A11C1930	290-0804-00				CAP, FXD, ELCTLT: 10UF, +50-10%, 25V	55680	ULB1E100TAAANA
A11C1940	281-0773-00				CAP, FXD, CER DI: 0.01UF, 10%, 100V	04222	MA201C103KAA
A11C1960	283-0203-00				CAP, FXD, CER DI: 0.47UF, 20%, 50V	04222	SR305SC474MAA
A11C1961	283-0203-00				CAP, FXD, CER DI: 0.47UF, 20%, 50V	04222	SR305SC474MAA
A11C1965	281-0813-00				CAP, FXD, CER DI: 0.047UF, 20%, 50V	05397	C412C473M5V2CA
A11C2010	290-0900-00				CAP, FXD, ELCTLT: 1600UF, +100-10%, 50V	56289	674D168H050JP5A
A11C2030	290-0930-00				CAP, FXD, ELCTLT: 11000UF, +100-10%, 12V	56289	674D119H012JS5A
A11C2040	283-0672-00				CAP, FXD, MICA DI: 200PF, 1%, 500V	00853	D155F2010F0
A11C2050	283-0659-00				CAP, FXD, MICA DI: 1160PF, 2%, 500V	00853	D195F1161G0
A11C2051	290-0771-00				CAP, FXD, ELCTLT: 220UF, +50-10%, 10VDC	55680	ULA1A221TPA2
A11C2052	281-0788-00				CAP, FXD, CER DI: 470PF, 10%, 100V	04222	MA101C471KAA
A11C2060	290-0771-00				CAP, FXD, ELCTLT: 220UF, +50-10%, 10VDC	55680	ULA1A221TPA2
A11C2065	283-0142-00				CAP, FXD, CER DI: 0.0027UF, 5%, 200V	54583	CK45YE2D272J-A
A11C2066	281-0775-00				CAP, FXD, CER DI: 0.1UF, 20%, 50V	04222	MA205E104MAA
A11C2100	290-0818-00				CAP, FXD, ELCTLT: 390UF, +100-10%, 40V	56289	672D397H040DS5C
A11C2120	290-0930-00				CAP, FXD, ELCTLT: 11000UF, +100-10%, 12V	56289	674D119H012JS5A
A11C2140	281-0773-00				CAP, FXD, CER DI: 0.01UF, 10%, 100V	04222	MA201C103KAA
A11C2150	285-0889-00				CAP, FXD, PLASTIC: 0.0027UF, 5%, 100V	19396	DU490/74-28221
A11C2151	290-0804-00				CAP, FXD, ELCTLT: 10UF, +50-10%, 25V	55680	ULB1E100TAAANA
A11C2160	281-0773-00				CAP, FXD, CER DI: 0.01UF, 10%, 100V	04222	MA201C103KAA
A11C2200	290-0818-00				CAP, FXD, ELCTLT: 390UF, +100-10%, 40V	56289	672D397H040DS5C
A11C2230	283-0203-00				CAP, FXD, CER DI: 0.47UF, 20%, 50V	04222	SR305SC474MAA
A11C2231	283-0203-00				CAP, FXD, CER DI: 0.47UF, 20%, 50V	04222	SR305SC474MAA
A11C2232	283-0203-00				CAP, FXD, CER DI: 0.47UF, 20%, 50V	04222	SR305SC474MAA
A11C2240	281-0814-00				CAP, FXD, CER DI: 100 PF, 10%, 100V	04222	MA101A101KAA
A11C2260	290-0919-00				CAP, FXD, ELCTLT: 470UF, +50-10%, 35V	TK0510	ECEA1VV471SC
A11C2300	290-0818-00				CAP, FXD, ELCTLT: 390UF, +100-10%, 40V	56289	672D397H040DS5C
A11C2310	290-0818-00				CAP, FXD, ELCTLT: 390UF, +100-10%, 40V	56289	672D397H040DS5C

Replaceable Electrical Parts - TM 5006

Component No.	Tektronix Part No.	Serial/Assembly No. Effective	Discont	Name & Description	Mfr. Code	Mfr. Part No.
A11C2350	290-0891-00	B010100	B033969	CAP, FXD, ELCTLT: 1UF, +75 -10%, 50V	55680	ULA1H010TEA
A11C2350	290-0974-00	B033970		CAP, FXD, ELCTLT: 10UF, 20%, 50VDC	55680	ULB1H100MAA
A11CR1500	152-0750-00			SEMICON DVC, DI: RECT BRDG, 600V, 3A, FAST RCVY	05828	RKBPC606-12
A11CR1540	152-0655-00			SEMICON DVC, DI: RECT, SI, 100V, 3A	03508	A115AX39
A11CR1541	152-0400-00			SEMICON DVC, DI: RECT, SI, 400V, 1A	04713	SR1977K
A11CR1550	152-0655-00			SEMICON DVC, DI: RECT, SI, 100V, 3A	03508	A115AX39
A11CR1551	152-0400-00			SEMICON DVC, DI: RECT, SI, 400V, 1A	04713	SR1977K
A11CR1730	152-0107-00			SEMICON DVC, DI: RECT, SI, 400 V, 400MA, A1	12969	"G727"
A11CR1731	152-0107-00			SEMICON DVC, DI: RECT, SI, 400 V, 400MA, A1	12969	"G727"
A11CR1810	152-0686-00			SEMICON DVC, DI: RECT, SI, 100V, 5A, A264	04713	SR3273
A11CR1850	152-0141-02			SEMICON DVC, DI: SW, SI, 30V, 150MA, 30V, DO-35	03508	DA2527 (1N4152)
A11CR1860	152-0141-02			SEMICON DVC, DI: SW, SI, 30V, 150MA, 30V, DO-35	03508	DA2527 (1N4152)
A11CR1861	152-0141-02			SEMICON DVC, DI: SW, SI, 30V, 150MA, 30V, DO-35	03508	DA2527 (1N4152)
A11CR1862	152-0141-02			SEMICON DVC, DI: SW, SI, 30V, 150MA, 30V, DO-35	03508	DA2527 (1N4152)
A11CR1863	152-0141-02			SEMICON DVC, DI: SW, SI, 30V, 150MA, 30V, DO-35	03508	DA2527 (1N4152)
A11CR1900	152-0686-00			SEMICON DVC, DI: RECT, SI, 100V, 5A, A264	04713	SR3273
A11CR1910	152-0686-00			SEMICON DVC, DI: RECT, SI, 100V, 5A, A264	04713	SR3273
A11CR1911	152-0686-00			SEMICON DVC, DI: RECT, SI, 100V, 5A, A264	04713	SR3273
A11CR1950	152-0141-02			SEMICON DVC, DI: SW, SI, 30V, 150MA, 30V, DO-35	03508	DA2527 (1N4152)
A11CR2040	152-0141-02			SEMICON DVC, DI: SW, SI, 30V, 150MA, 30V, DO-35	03508	DA2527 (1N4152)
A11CR2041	152-0141-02			SEMICON DVC, DI: SW, SI, 30V, 150MA, 30V, DO-35	03508	DA2527 (1N4152)
A11CR2042	152-0141-02			SEMICON DVC, DI: SW, SI, 30V, 150MA, 30V, DO-35	03508	DA2527 (1N4152)
A11CR2043	152-0141-02			SEMICON DVC, DI: SW, SI, 30V, 150MA, 30V, DO-35	03508	DA2527 (1N4152)
A11CR2130	152-0141-02			SEMICON DVC, DI: SW, SI, 30V, 150MA, 30V, DO-35	03508	DA2527 (1N4152)
A11CR2149	152-0141-02			SEMICON DVC, DI: SW, SI, 30V, 150MA, 30V, DO-35	03508	DA2527 (1N4152)
A11CR2150	152-0141-02			SEMICON DVC, DI: SW, SI, 30V, 150MA, 30V, DO-35	03508	DA2527 (1N4152)
A11CR2230	152-0141-02			SEMICON DVC, DI: SW, SI, 30V, 150MA, 30V, DO-35	03508	DA2527 (1N4152)
A11CR2240	152-0141-02			SEMICON DVC, DI: SW, SI, 30V, 150MA, 30V, DO-35	03508	DA2527 (1N4152)
A11CR2340	152-0066-00			SEMICON DVC, DI: RECT, SI, 400V, 1A, DO-41	05828	GP10G-020
A11CR2341	152-0066-00			SEMICON DVC, DI: RECT, SI, 400V, 1A, DO-41	05828	GP10G-020
A11CR2349	152-0141-02			SEMICON DVC, DI: SW, SI, 30V, 150MA, 30V, DO-35	03508	DA2527 (1N4152)
A11CR2350	152-0066-00			SEMICON DVC, DI: RECT, SI, 400V, 1A, DO-41	05828	GP10G-020
A11CR2351	152-0066-00			SEMICON DVC, DI: RECT, SI, 400V, 1A, DO-41	05828	GP10G-020
A11CR2360	152-0141-02			SEMICON DVC, DI: SW, SI, 30V, 150MA, 30V, DO-35	03508	DA2527 (1N4152)
A11DS1600	150-0030-00			LAMP, GLOW: 60-90V MAX, 0.7MA, A28-T, WIRE LEADS	58224	A28-T
A11E1300	119-0181-00			ARSR, ELEC SURGE: 230, GAS FILLED	25088	B1-A230
A11E1400	119-0181-00			ARSR, ELEC SURGE: 230, GAS FILLED	25088	B1-A230
A11E1620	276-0640-00			CORE, EM: TOROID, FERRITE	56880	J-41005-TC
A11F2340	159-0022-00			FUSE, CARTRIDGE: 3AG, 1A, 250V, FAST BLOW	71400	AGC-CW-1
A11J1000	131-0608-00			TERMINAL, PIN: 0.365 L X 0.025 BRZ GLD PL (QTY 4)	22526	48283-036
A11J1010	131-0608-00			TERMINAL, PIN: 0.365 L X 0.025 BRZ GLD PL (QTY 2)	22526	48283-036
A11J1011	131-0608-00			TERMINAL, PIN: 0.365 L X 0.025 BRZ GLD PL (QTY 4)	22526	48283-036
A11J1012	131-0608-00			TERMINAL, PIN: 0.365 L X 0.025 BRZ GLD PL (QTY 4)	22526	48283-036
A11J1013	131-0608-00			TERMINAL, PIN: 0.365 L X 0.025 BRZ GLD PL (QTY 4)	22526	48283-036
A11J1020	131-0608-00			TERMINAL, PIN: 0.365 L X 0.025 BRZ GLD PL (QTY 4)	22526	48283-036
A11J2220	131-1688-00			TERM, QIK DISC.: MALE, 0.032 X 0.25 BL	00779	42577-4
A11J2221	131-1688-00			TERM, QIK DISC.: MALE, 0.032 X 0.25 BL	00779	42577-4
A11J2320	131-1688-00			TERM, QIK DISC.: MALE, 0.032 X 0.25 BL	00779	42577-4
A11J2321	131-1688-00			TERM, QIK DISC.: MALE, 0.032 X 0.25 BL	00779	42577-4
A11J2330	131-0608-00			TERMINAL, PIN: 0.365 L X 0.025 BRZ GLD PL (QTY 3)	22526	48283-036
A11L1020	108-0902-00			COIL, RF: FIXED, 50UH	80009	108-0902-00
A11L1030	108-0902-00			COIL, RF: FIXED, 50UH	80009	108-0902-00

Component No.	Tektronix		Serial/Assembly No.		Name & Description	Mfr. Code	Mfr. Part No.
	Part No.		Effective	Dscont			
A11L1100	108-1037-00				COIL, RF: FXD, 500UH	TK1345	108-1037-00
A11L1320	108-0973-00				COIL, RF: FIXED, 140UH	80009	108-0973-00
A11L1440	108-1051-00				COIL, RF: FIXED, 1MH	80009	108-1051-00
A11L2100	108-1022-00				COIL, RF: FIXED, 8.85UH	TK1345	108-1022-00
A11L2130	108-0950-00				COIL, RF: FIXED, 5.5UH	TK1345	108-0950-0
A11L2210	108-1022-00				COIL, RF: FIXED, 8.85UH	TK1345	108-1022-00
A11Q1730	151-0302-00				TRANSISTOR: NPN, SI, TO-18	04713	ST899
A11Q1731	151-0302-00				TRANSISTOR: NPN, SI, TO-18	04713	ST899
A11Q2240	151-0190-00				TRANSISTOR: NPN, SI, TO-92	80009	151-0190-00
A11R1040	315-0561-00				RES, FXD, FILM: 560 OHM, 5%, 0.25W	19701	5043CX560R0J
A11R1100	315-0361-00				RES, FXD, FILM: 360 OHM, 5%, 0.25W	19701	5043CX360R0J
A11R1350	315-0101-00				RES, FXD, FILM: 100 OHM, 5%, 0.25W	57668	NTR25J-E 100E
A11R1351	308-0426-00				RES, FXD, WW: 470 OHM, 5%, 3W	00213	1240S-470-5
A11R1352	305-0470-00				RES, FXD, CMPSN: 47 OHM, 5%, 2W	01121	HB 4705
A11R1420	303-0104-00				RES, FXD, CMPSN: 100K OHM, 5%, 1W	01121	GB1045
A11R1421	303-0104-00				RES, FXD, CMPSN: 100K OHM, 5%, 1W	01121	GB1045
A11R1422	315-0240-00				RES, FXD, FILM: 24 OHM, 5%, 0.25W	57668	NTR25J-E24E0
A11R1430	308-0499-00				RES, FXD, WW: 0.5 OHM, 10%, 2.5W, AXIAL	14193	SA31 R500K
A11R1460	308-0686-00	B010100	B020199		RES, FXD, WW: 2.2 OHM, 5%, 2W	75042	BWH-2R200J
A11R1460	308-0703-00	B020200			RES, FXD, WW: 1.8 OHM, 5%, 2W	75042	BWH 1.8 OHM 5%
A11R1530	308-0686-00	B010100	B020199		RES, FXD, WW: 2.2 OHM, 5%, 2W	75042	BWH-2R200J
A11R1530	308-0703-00	B020200			RES, FXD, WW: 1.8 OHM, 5%, 2W	75042	BWH 1.8 OHM 5%
A11R1600	301-0685-00				RES, FXD, FILM: 6.8M OHM, 5%, 0.5W	01121	EB6855
A11R1620	301-0331-00				RES, FXD, FILM: 330 OHM, 5%, 0.5W	19701	5053CX330R0J
A11R1830	315-0152-00				RES, FXD, FILM: 1.5K OHM, 5%, 0.25W	57668	NTR25J-E01K5
A11R1831	315-0152-00				RES, FXD, FILM: 1.5K OHM, 5%, 0.25W	57668	NTR25J-E01K5
A11R1832	315-0103-00				RES, FXD, FILM: 10K OHM, 5%, 0.25W	19701	5043CX10K00J
A11R1850	321-0356-00	B010100	B021519		RES, FXD, FILM: 49.9K OHM, 1%, 0.125W, TC=TO	19701	5033ED49K90F
A11R1850	321-0306-00	B021520			RES, FXD, FILM: 15.0K OHM, 1%, 0.125W, TC=TO	19701	5033ED15J00F
A11R1850	321-0306-00	B021520	B033969		RES, FXD, FILM: 15.0K OHM, 1%, 0.125W, TC=TO	19701	5033ED15J00F
A11R1850	321-0335-00	B033970			RES, FXD, FILM: 30.1K OHM, 1%, 0.125W, TC=TO	57668	RB14FXE30K1
A11R1851	321-0279-00				RES, FXD, FILM: 7.87K OHM, 1%, 0.125W, TC=TO	07716	CEAD78700F
A11R1852	321-0349-00	B010100	B033969		RES, FXD, FILM: 42.2K OHM, 1%, 0.125W, TC=TO	07716	CEAD42201F
A11R1852	321-0335-00	B033970			RES, FXD, FILM: 30.1K OHM, 1%, 0.125W, TC=TO	57668	RB14FXE30K1
A11R1855	311-1232-00	B021520	B033969		RES, VAR, NONWW: TRMR, 50K OHM, 0.5W	32997	3386F-T04-503
A11R1855	311-1231-00	B033970			RES, VAR, NONWW: TRMR, 25K OHM, 0.5W	32997	3386F-T04-253
A11R1860	323-0095-00				RES, FXD, FILM: 95.3 OHM, 1%, 0.5W, TC=TO	75042	CECT0-95R30F
A11R1930	321-0308-00				RES, FXD, FILM: 15.8K OHM, 1%, 0.125W, TC=TO	07716	CEAD 15801F
A11R1931	315-0224-00				RES, FXD, FILM: 220K OHM, 5%, 0.25W	57668	NTR25J-E220K
A11R1950	315-0103-00				RES, FXD, FILM: 10K OHM, 5%, 0.25W	19701	5043CX10K00J
A11R1951	315-0471-00				RES, FXD, FILM: 470 OHM, 5%, 0.25W	57668	NTR25J-E470E
A11R1952	315-0104-00				RES, FXD, FILM: 100K OHM, 5%, 0.25W	57668	NTR25J-E100K
A11R1953	315-0102-00				RES, FXD, FILM: 1K OHM, 5%, 0.25W	57668	NTR25JE01K0
A11R1960	315-0103-00	B010100	B010119		RES, FXD, FILM: 10K OHM, 5%, 0.25W	19701	5043CX10K00J
A11R1960	315-0332-00	B010120			RES, FXD, FILM: 3.3K OHM, 5%, 0.25W	57668	NTR25J-E03K3
A11R1961	315-0751-00				RES, FXD, FILM: 750 OHM, 5%, 0.25W	57668	NTR25J-E750E
A11R1962	315-0103-00				RES, FXD, FILM: 10K OHM, 5%, 0.25W	19701	5043CX10K00J
A11R1963	315-0913-00				RES, FXD, FILM: 91K OHM, 5%, 0.25W	19701	5043CX91K00J
A11R2040	315-0103-00				RES, FXD, FILM: 10K OHM, 5%, 0.25W	19701	5043CX10K00J
A11R2041	315-0103-00				RES, FXD, FILM: 10K OHM, 5%, 0.25W	19701	5043CX10K00J
A11R2042	315-0103-00				RES, FXD, FILM: 10K OHM, 5%, 0.25W	19701	5043CX10K00J
A11R2050	315-0154-00				RES, FXD, FILM: 150K OHM, 5%, 0.25W	57668	NTR25J-E150K
A11R2060	311-1228-00				RES, VAR, NONWW: TRMR, 10K OHM, 0.5W	32997	3386F-T04-103
A11R2061	315-0223-00				RES, FXD, FILM: 22K OHM, 5%, 0.25W	19701	5043CX22K00J92U
A11R2063	315-0223-00				RES, FXD, FILM: 22K OHM, 5%, 0.25W	19701	5043CX22K00J92U
A11R2064	315-0333-00				RES, FXD, FILM: 33K OHM, 5%, 0.25W	57668	NTR25J-E33K0
A11R2130	321-0225-00				RES, FXD, FILM: 2.15K OHM, 1%, 0.125W, TC=TO	19701	5033ED2K15F
A11R2132	321-0279-00				RES, FXD, FILM: 7.87K OHM, 1%, 0.125W, TC=TO	07716	CEAD78700F

Replaceable Electrical Parts - TM 5006

Component No.	Tektronix Part No.	Serial/Assembly No. Effective	Dscont	Name & Description	Mfr. Code	Mfr. Part No.
A11R2133	315-0224-00			RES, FXD, FILM:220K OHM, 5%, 0.25W	57668	NTR25J-E220K
A11R2140	315-0104-00			RES, FXD, FILM:100K OHM, 5%, 0.25W	57668	NTR25J-E100K
A11R2141	315-0104-00			RES, FXD, FILM:100K OHM, 5%, 0.25W	57668	NTR25J-E100K
A11R2150	315-0104-00			RES, FXD, FILM:100K OHM, 5%, 0.25W	57668	NTR25J-E100K
A11R2151	311-1225-00			RES, VAR, NONMW:TRMR, 1K OHM, 0.5W	32997	3386F-T04-102
A11R2220	308-0402-00			RES, FXD, WW:30 OHM, 5%, 5W	05347	CS5-30R0J
A11R2230	321-0279-00			RES, FXD, FILM:7.87K OHM, 1%, 0.125W, TC=TO	07716	CEAD78700F
A11R2231	321-0322-00			RES, FXD, FILM:22.1K OHM, 0.1%, 0.125W, TC=TO	19701	5033ED22K10F
A11R2232	315-0751-00			RES, FXD, FILM:750 OHM, 5%, 0.25W	57668	NTR25J-E750E
A11R2233	315-0104-00			RES, FXD, FILM:100K OHM, 5%, 0.25W	57668	NTR25J-E100K
A11R2240	321-0338-00			RES, FXD, FILM:32.4K OHM, 1%, 0.125W, TC=TO	19701	5033ED32K40F
A11R2241	315-0913-00	B010100	B033969	RES, FXD, FILM:91K OHM, 5%, 0.25W	19701	5043CX91K00J
A11R2241	315-0134-00	B033970		RES, FXD, FILM:130K OHM, 5%, 0.25W	57668	NTR25J-E130K
A11R2242	321-0279-00			RES, FXD, FILM:7.87K OHM, 1%, 0.125W, TC=TO	07716	CEAD78700F
A11R2243	315-0223-00			RES, FXD, FILM:22K OHM, 5%, 0.25W	19701	5043CX22K00J92U
A11R2244	321-0249-00			RES, FXD, FILM:3.83K OHM, 1%, 0.125W, TC=TO	19701	5033ED3K83F
A11R2250	315-0332-00			RES, FXD, FILM:3.3K OHM, 5%, 0.25W	57668	NTR25J-E03K3
A11R2251	321-0279-00			RES, FXD, FILM:7.87K OHM, 1%, 0.125W, TC=TO	07716	CEAD78700F
A11R2300	308-0426-00			RES, FXD, WW:470 OHM, 5%, 3W	00213	1240S-470-5
A11R2301	308-0426-00			RES, FXD, WW:470 OHM, 5%, 3W	00213	1240S-470-5
A11R2302	308-0426-00			RES, FXD, WW:470 OHM, 5%, 3W	00213	1240S-470-5
A11R2303	308-0426-00			RES, FXD, WW:470 OHM, 5%, 3W	00213	1240S-470-5
A11R2340	315-0822-00	B010100	B033969	RES, FXD, FILM:8.2K OHM, 5%, 0.25W	19701	5043CX8K200J
A11R2340	315-0821-00	B033970		RES, FXD, FILM:820 OHM, 5%, 0.25W	19701	5043CX820R0J
A11R2342	315-0223-00	B010100	B033969	RES, FXD, FILM:22K OHM, 5%, 0.25W	19701	5043CX22K00J92U
A11R2342	315-0302-00	B033970		RES, FXD, FILM:3K OHM, 5%, 0.25W	57668	NTR25J-E03K0
A11R2343	321-0241-00			RES, FXD, FILM:3.16K OHM, 1%, 0.125W, TC=TO	07716	CEAD31600F
A11R2350	315-0130-00			RES, FXD, FILM:13 OHM, 5%, 0.25W	01121	CB1305
A11R2351	315-0130-00			RES, FXD, FILM:13 OHM, 5%, 0.25W	01121	CB1305
A11R2352	315-0130-00			RES, FXD, FILM:13 OHM, 5%, 0.25W	01121	CB1305
A11R2360	315-0104-00			RES, FXD, FILM:100K OHM, 5%, 0.25W	57668	NTR25J-E100K
A11RT1000	307-0350-00			RES, THERMAL:7.5 OHM, 10%, 3.9%/DEG C	80009	307-0350-00
A11RT1200	307-0350-00			RES, THERMAL:7.5 OHM, 10%, 3.9%/DEG C	80009	307-0350-00
A11T1050	120-1337-00			TRANSFORMER, RF:COMMON MODE	80009	120-1337-00
A11T1710	120-1299-00			XFMR, PWR, STPON:HF	80009	120-1299-00
A11T1740	120-0744-00			XFMR, TOROID:5 WINDINGS	TK1345	120-0744-00
A11T1750	120-0747-00			XFMR, TOROID:	TK1345	120-0747-00
A11U1840	156-0745-01			MICROCKT, DGTL:HEX INVERTER, BURN-IN	02735	CD4069UBFX
A11U1940	156-1152-00			MICROCKT, DGTL:DUAL PRCN RETRIGGERABLE	04713	MC14538BCL
A11U1950	156-0754-02			MICROCKT, DGTL:DUAL 4-INPUT NOR GATE, SCRN	02735	CD4002BFX-88
A11U1951	156-0366-02			MICROCKT, DGTL:DUAL D FLIP-FLOP, SCREENED	02735	CD4013BFX
A11U2140	156-0411-00			MICROCKT, LINEAR:SGL SPLY COMPARATOR	04713	LM339N
A11U2160	156-0402-00			MICROCKT, LINEAR:TIMER	27014	LM555CN
A11U2250	156-0071-00			MICROCKT, LINEAR:VOLTAGE REGULATOR	04713	MC1723CL
A11VR2342	152-0243-00	B010100	B033969	SEMICON DVC, DI:ZEN, SI, 15V, 5%, 0.4W, DO-7	04713	SZ13203 (1N965B)
A11VR2342	152-0236-00	B033970		SEMICON DVC, DI:ZEN, SI, 12.5V, 4%, 0.4W, DO-7	04713	SZ13553RL
A11W1860	131-0566-00	B010100	B021519	BUS, CONDUCTOR:DUMMY RES, 0.094 OD X 0.225 L	24546	OMA 07
A15	670-6991-00	B010100	B020189	CIRCUIT BD ASSY:PASSIVE GPIB INTERCONNECT	80009	670-6991-00
A15J1010	131-1789-00			CONN, RCPT, ELEC:RTANG, 2/10 0.025 SQ PINS	22526	65268-008
A15J1110	131-2542-00			CONN, RCPT, ELEC:CKT BD, 24 CONTACT, RIGHT	00779	552791-2
A16	670-7179-00	B020190		CIRCUIT BD ASSY:GPIB INTERFACE	80009	670-7179-00
A16J1010	131-1789-00			CONN, RCPT, ELEC:RTANG, 2/10 0.025 SQ PINS	22526	65268-008
A16J1110	131-2542-00			CONN, RCPT, ELEC:CKT BD, 24 CONTACT, RIGHT	00779	552791-2
B500	119-0721-00			FAN, VENTILATING:75CFM, 115VAC, 50/60HZ (STANDARD ONLY)	82877	WR2H1
B500	119-0147-00			FAN, VENTILATING:115V, 14W, 3200RPM, 105CFM (OPTION 10, 12 ONLY)	82877	028021

Component No.	Tektronix Part No.	Serial/Assembly No. Effective	Dscnt	Name & Description	Mfr. Code	Mfr. Part No.
CR500	152-0762-00			SEMICON DVC,DI:RECT,SI,30A,40V,TO-3	01281	SD-241
F500	159-0036-00			FUSE,CARTRIDGE:3AG,7A,125V,FAST BLOW (STANDARD ONLY)	71400	GLH 7
F500	159-0017-00			FUSE,CARTRIDGE:3AG,4A,250V,FAST BLOW (OPTIONS A1,A2,A3 & A4 ONLY)	71400	MTH-CW-4
FL500	119-0420-00			FILTER,RFI:6A,250VAC,400HZ	02777	F-11935-6
Q500	151-0373-00			TRANSISTOR:PNP,SI,TD-127	04713	SJE925
Q510	151-0436-00			TRANSISTOR:NPN,SI,SEL,TO-172	04713	SJE966
Q520	151-0373-00			TRANSISTOR:PNP,SI,TD-127	04713	SJE925
Q530	151-0436-00			TRANSISTOR:NPN,SI,SEL,TO-172	04713	SJE966
Q540	151-0373-00			TRANSISTOR:PNP,SI,TD-127	04713	SJE925
Q550	151-0436-00			TRANSISTOR:NPN,SI,SEL,TO-172	04713	SJE966
Q560	151-0373-00			TRANSISTOR:PNP,SI,TD-127	04713	SJE925
Q570	151-0436-00			TRANSISTOR:NPN,SI,SEL,TO-172	04713	SJE966
Q580	151-0373-00			TRANSISTOR:PNP,SI,TD-127	04713	SJE925
Q590	151-0436-00			TRANSISTOR:NPN,SI,SEL,TO-172	04713	SJE966
Q600	151-0258-00			TRANSISTOR:PNP,SI,TO-3	02735	TO BE ASSIGNED
Q610	151-0140-00			TRANSISTOR:NPN,SI,TO-3	04713	SJ7020
Q1640	151-0632-00	B010100	B020199	TRANSISTOR:NPN,SILICON,TO-220	04713	SJE1946
Q1640	151-0679-00	B020200		TRANSISTOR:NPN,SI,TO-220	04713	MJE13009
Q1650	151-0632-00	B010100	B020199	TRANSISTOR:NPN,SILICON,TO-220	04713	SJE1946
Q1650	151-0679-00	B020200		TRANSISTOR:NPN,SI,TO-220	04713	MJE13009
S500	260-1961-00			SWITCH,ROCKER:DPST,6(4)A,250V	TK0935	1802.1121
S550	260-1710-00			SWITCH,THRMSTC:OPEN 92.97,CL 80.4,10A,240V	14604	2450-47-16
T500	120-1298-00			XFMR,PWR,STPDN:LF	80009	120-1298-00

DIAGRAMS AND CIRCUIT BOARD ILLUSTRATIONS

Symbols

Graphic symbols and class designation letters are based on ANSI Standard Y32.2-1975.

Logic symbology is based on ANSI Y32.14-1973 in terms of positive logic. Logic symbols depict the logic function performed and may differ from the manufacturer's data.

The overline on a signal name indicates that the signal performs its intended function when it is in the low state.

Abbreviations are based on ANSI Y1.1-1972.

Other ANSI standards that are used in the preparation of diagrams by Tektronix, Inc. are:

- Y14.15, 1966 Drafting Practices.
- Y14.2, 1973 Line Conventions and Lettering.
- Y10.5, 1968 Letter Symbols for Quantities Used in Electrical Science and Electrical Engineering.

American National Standard Institute
1430 Broadway
New York, New York 10018

Component Values

Electrical components shown on the diagrams are in the following units unless noted otherwise:

- Capacitors = Values one or greater are in picofarads (pF). Values less than one are in microfarads (μ F).
- Resistors = Ohms (Ω).

————— The information and special symbols below may appear in this manual. —————

Assembly Numbers and Grid Coordinates

Each assembly in the instrument is assigned an assembly number (e.g., A20). The assembly number appears on the circuit board outline on the diagram, in the title for the circuit board component location illustration, and in the lookup table for the schematic diagram and corresponding component locator illustration. The Replaceable Electrical Parts list is arranged by assemblies in numerical sequence; the components are listed by component number *(see following illustration for constructing a component number).

The schematic diagram and circuit board component location illustration have grids. A lookup table with the grid coordinates is provided for ease of locating the component. Only the components illustrated on the facing diagram are listed in the lookup table. When more than one schematic diagram is used to illustrate the circuitry on a circuit board, the circuit board illustration may only appear opposite the first diagram on which it was illustrated; the lookup table will list the diagram number of other diagrams that the circuitry of the circuit board appears on.

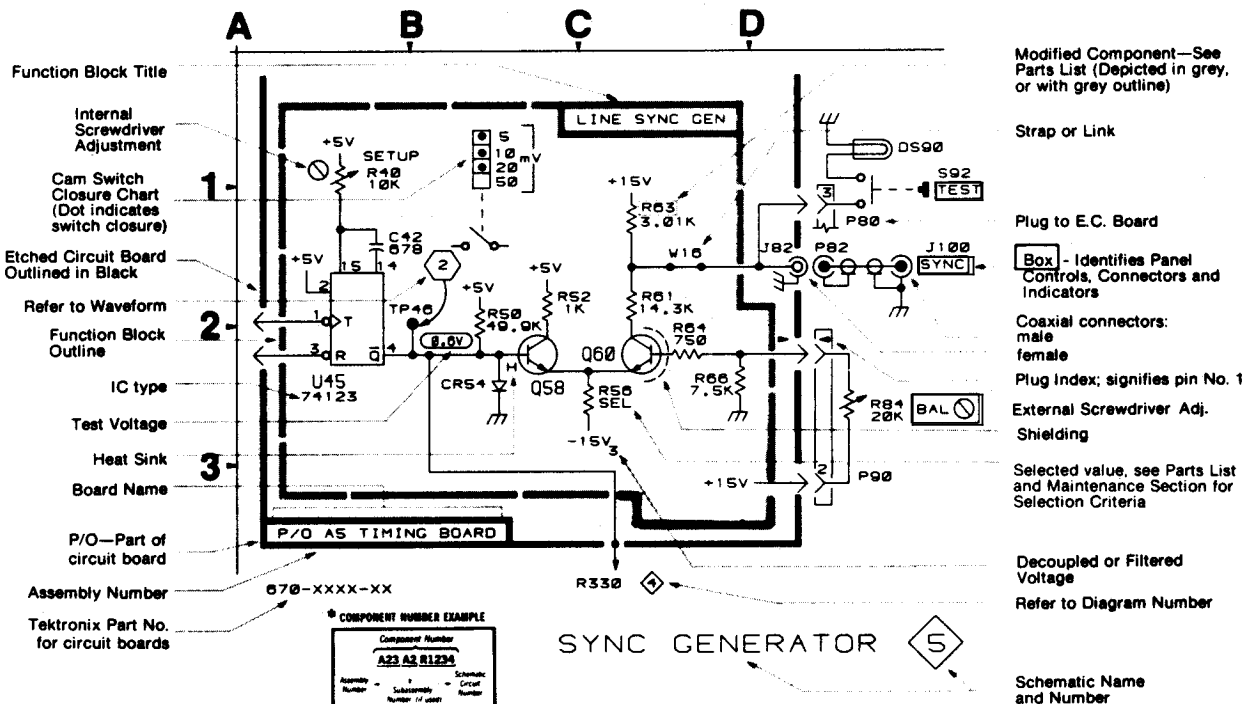

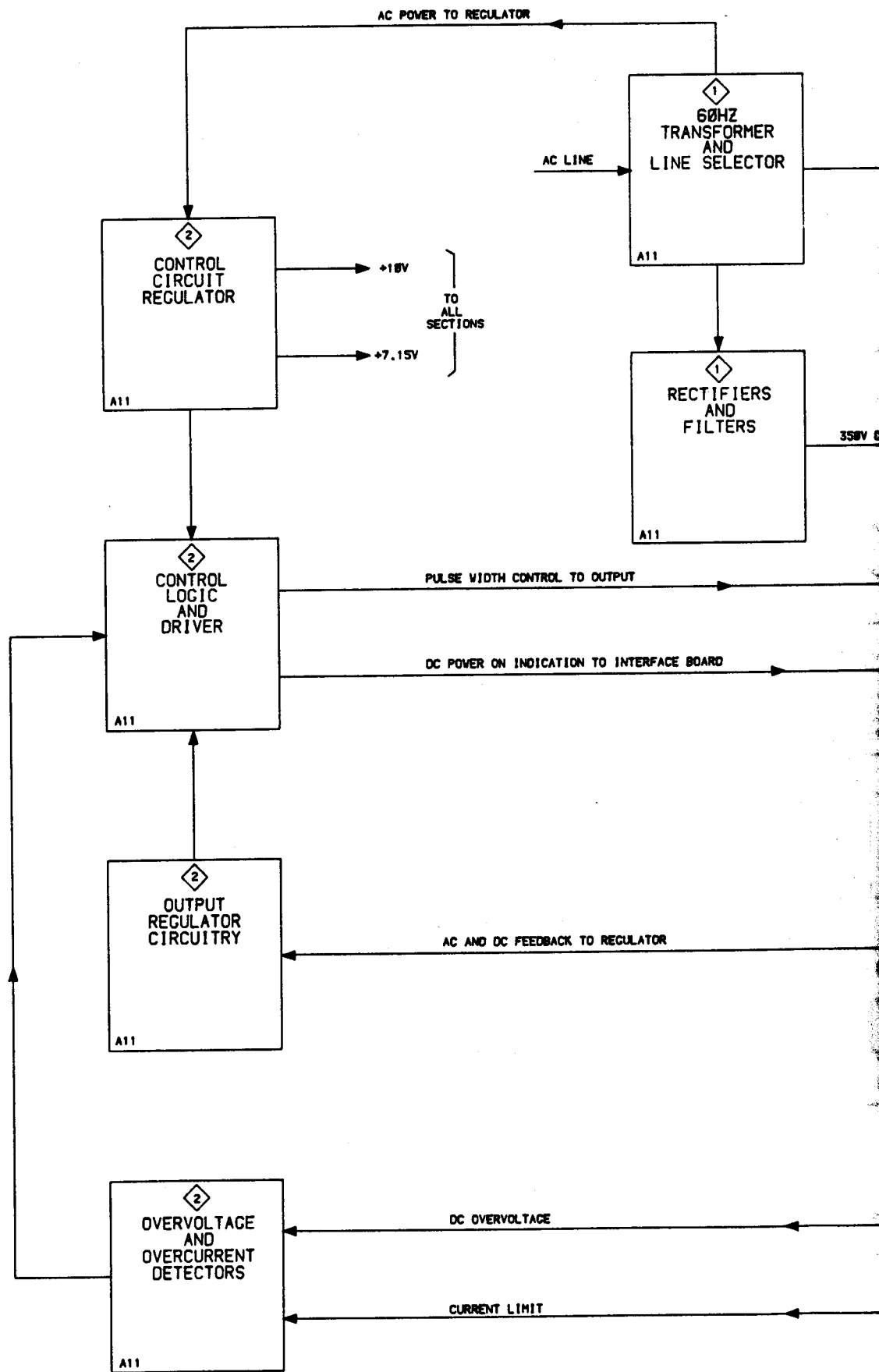

TM 5006

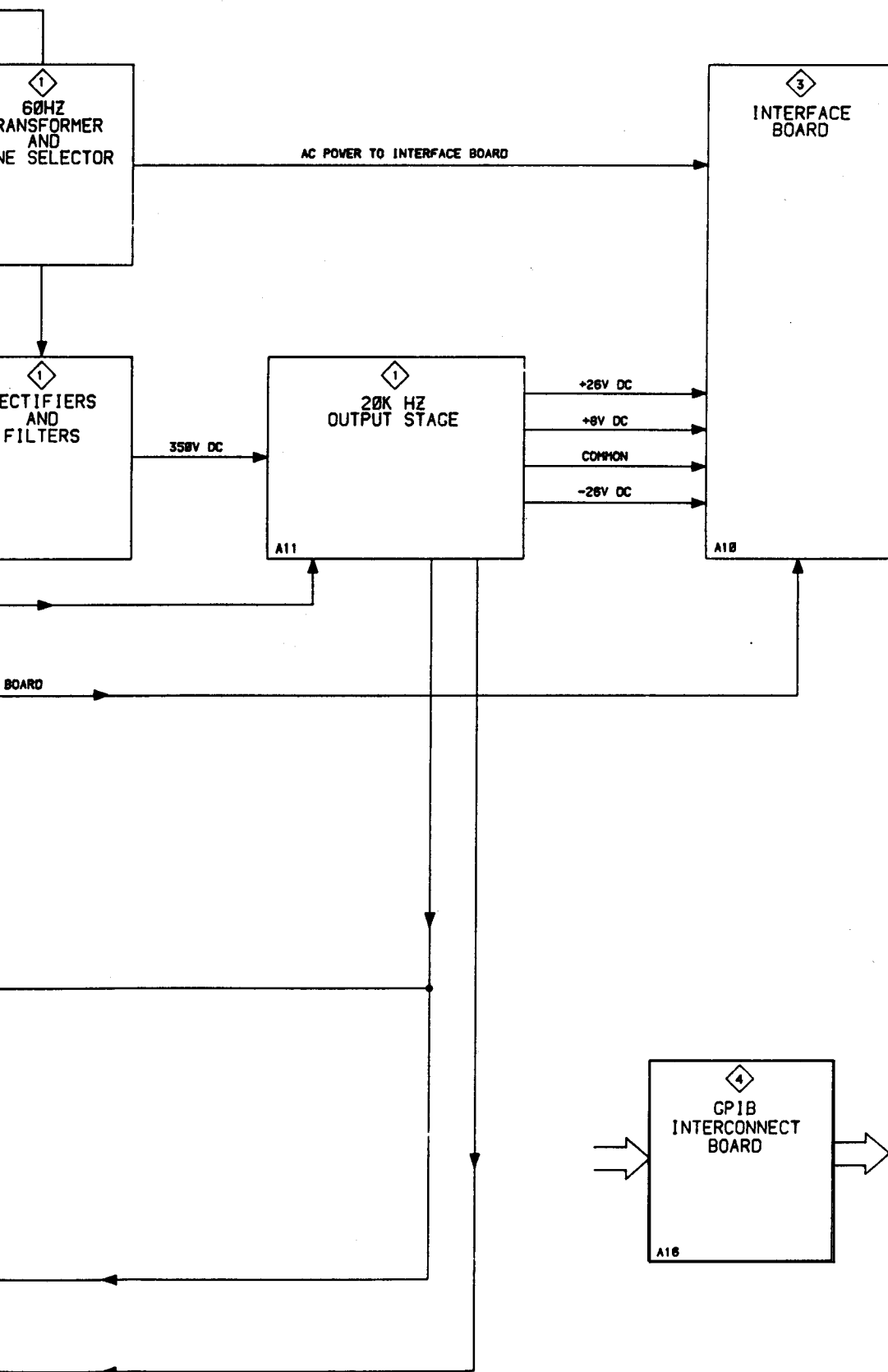

BLOCK DIAGRAM

JS

ION GRID

01B

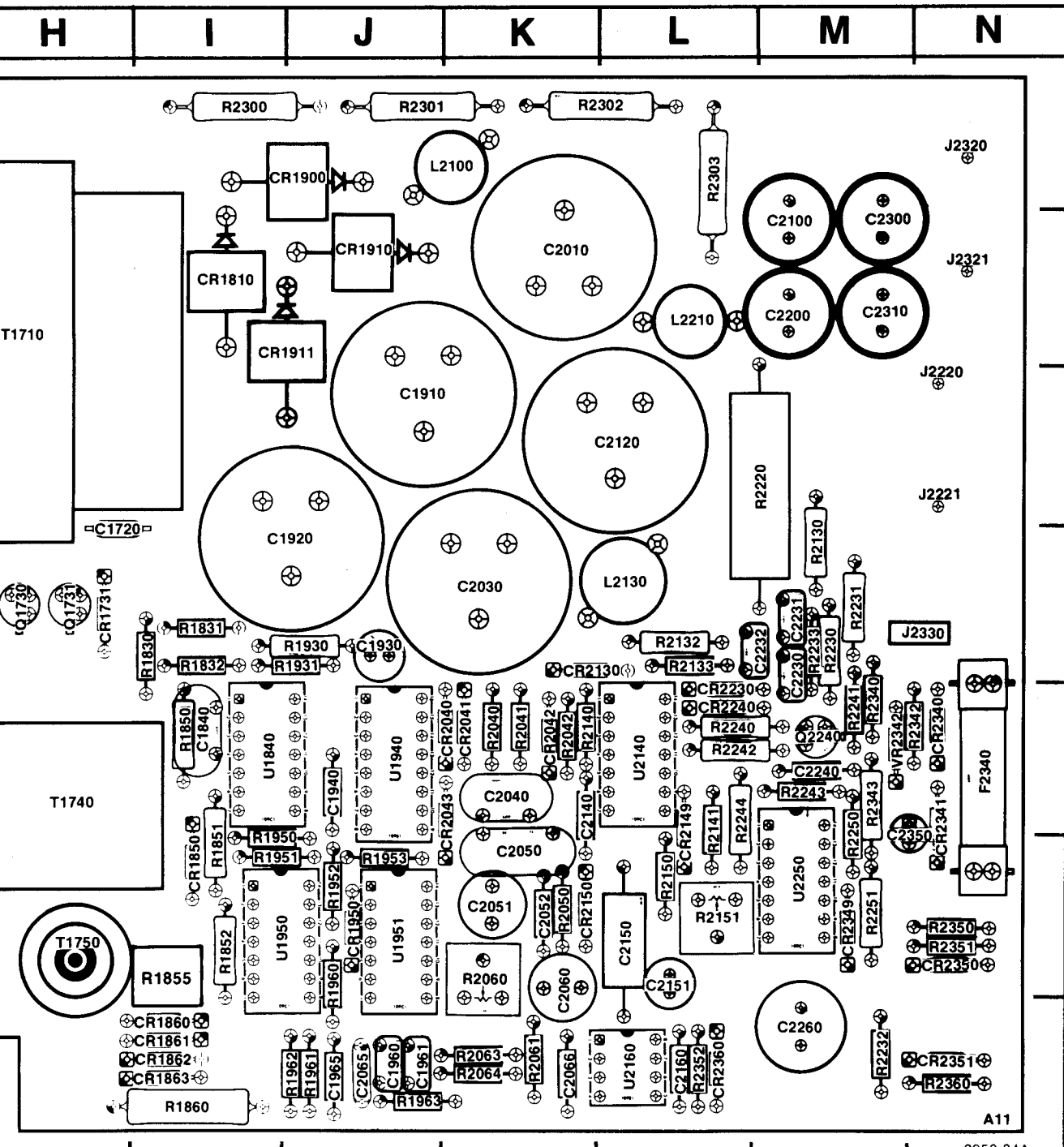

2950-34A

ASSY A11

Board (Assy A11).

REV NOV 1984

PARTS LOCAT

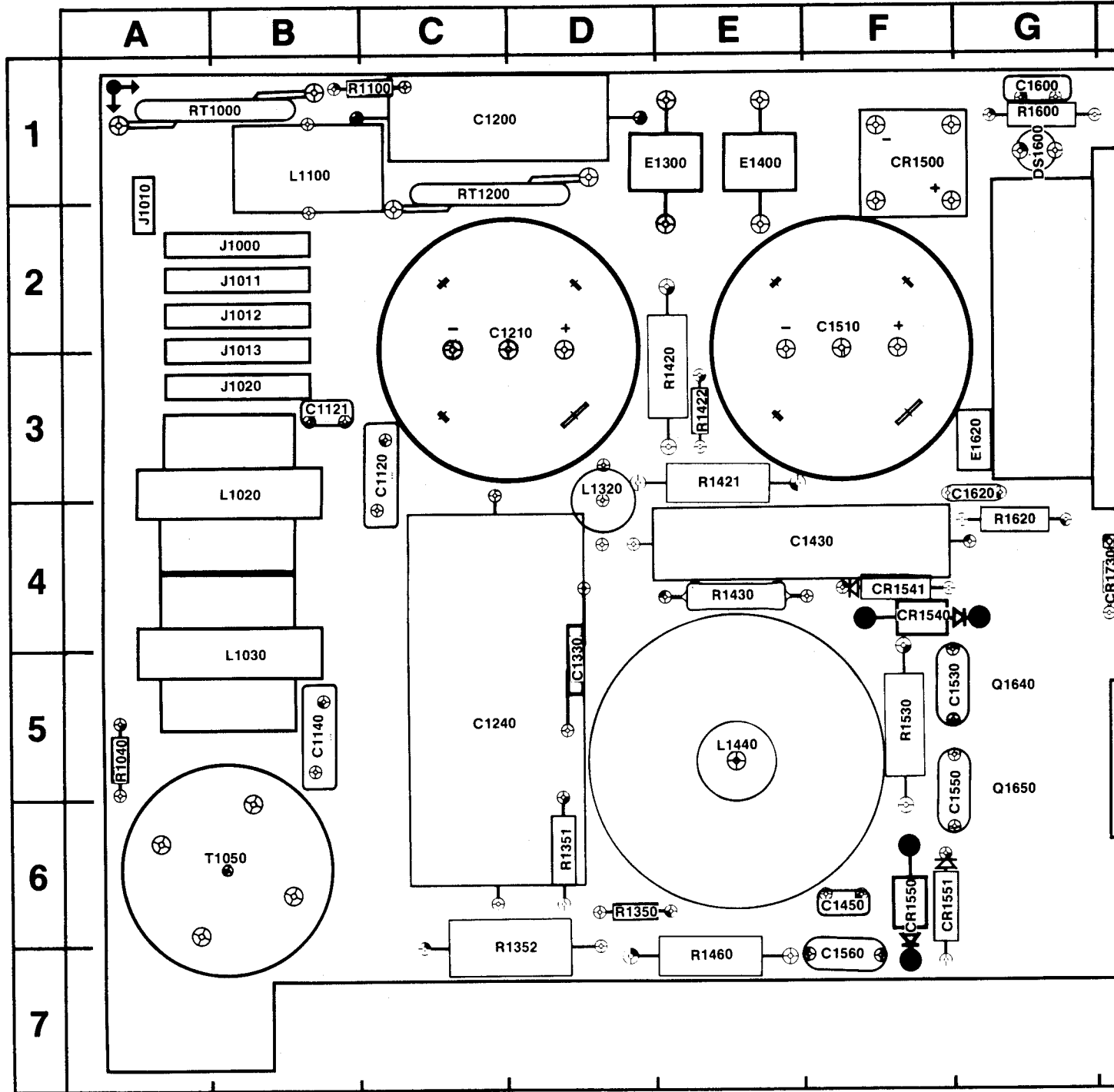
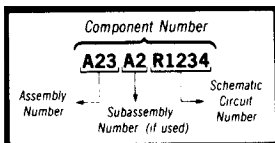

Fig. 8-1. Dc Power Suppl

⊗ Static Sensitive Devices
See Maintenance Section

COMPONENT NUMBER EXAMPLE



Chassis-mounted components have no Assembly Number prefix—see end of Replaceable Electrical Parts List.

Table 8-1 COMPONENT REFERENCE CHART

A11 DC POWER SUPPLY BOARD

P/O A11 ASSY			DC POWER SUPPLY 1		
CIRCUIT NUMBER	SCHEMATIC LOCATION	BOARD LOCATION	CIRCUIT NUMBER	SCHEMATIC LOCATION	BOARD LOCATION
C1120	C3	C3	L1020	C3	B3
C1121*	D2	B3	L1030	C2	B5
C1140	C1	B5	L1100	C4	B1
C1200	B5	C1	L1320	E5	D3
C1210	D6	D2	L1440	H5	E5
C1240	F5	C5	L2100	L5	K1
C1330	H5	D5	L2130	L6	L4
C1430	H5	F4	L2210	L8	L2
C1450	F7	F6			
C1510	D5	F2	P1011	C2	B2
C1530	D6	F5	P1013	E1	B2
C1550	F6	F5	P2220	M6	N3
C1560	D7	F7	P2221	M6	N3
C1600	E6	G1	P2320	M5	N1
C1620	H7	G3	P2321	M8	N2
C1720	L7	H4			
C1910	L8	J3	Q1640	F6	G5
C1920	L6	J4	Q1650	F7	G5
C2010	L5	K2			
C2030	L6	K4	R1040	B2	A5
C2100	L5	M2	R1100	C4	C1
C2120	L6	L3	R1350	F6	D6
C2200	L8	M2	R1351	H6	D6
C2300	L5	M2	R1352	F7	D7
C2310	M8	M2	R1420	D6	E3
CR1500	C5	F1	R1421	D5	E3
CR1550	F7	F6	R1422	E5	E3
CR1540	F6	F4	R1430	F5	E4
CR1541	F5	F4	R1460	D7	E7
CR1551	F7	F6	R1530	D6	F5
CR1810	K5	I2	R1600	E5	G1
CR1860	B8	I7	R1620	H6	G4
CR1861	B8	I7	R2220	M6	M3
CR1862	B8	I7	R2300	K8	I1
CR1863	B8	I7	R2301	L8	J1
CR1900	K5	J1	R2302	M5	L1
CR1910	K8	J2	R2303	M5	L1
CR1911	K8	J2			
DS1600	E6	G1	RT1000	C4	A1
			RT1200	B4	C1
E1300	D4	E1	T1050	B2	B6
E1400	D5	E1	T1710	J5	H2
E1620	H7	G3	T1740	C6	H5
			T1750	C8	H6
J1000	D2	B2	B500	E4	Chassis
J1010	F4	A1	CR500	K6	Chassis
J1011	C2	B2	F500	A3	Chassis
J1012	D1	B2	FL500	A4	Chassis
J1013	E1	B2	S500	A3	Chassis
J1020	F1	B3	S550	A2	Chassis
J2220	M6	N3			
J2221	M6	N3			
J2320	M5	N1			
J2321	M8	N2			

*See Parts List for serial number ranges.

P/O A11 ASSY also shown on 2

A | B | C | D | E | F | H

1
2
3
4
5
6
7
8

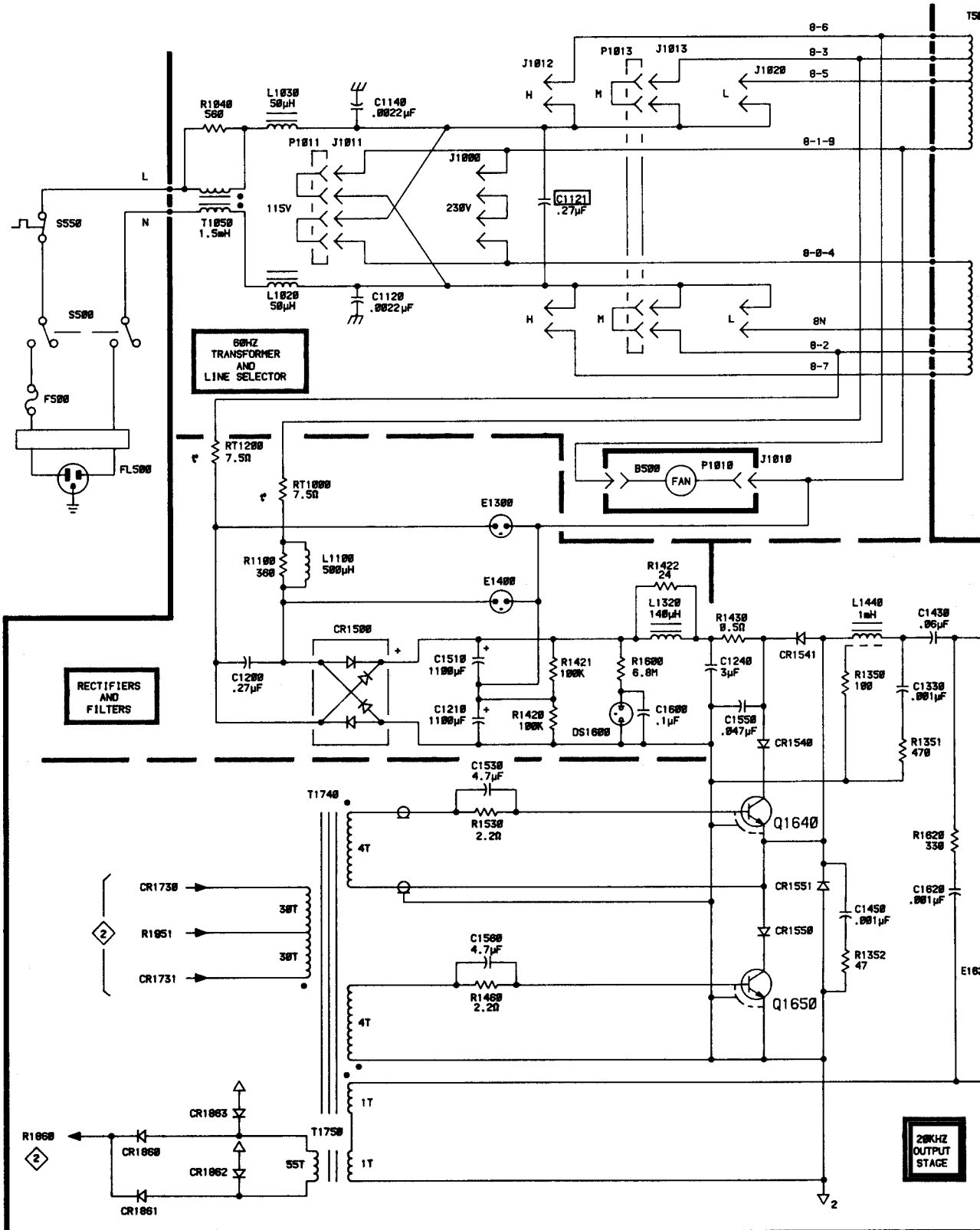

TM 5006

REV NOV 1984
2850-48

H | J | K | L | M

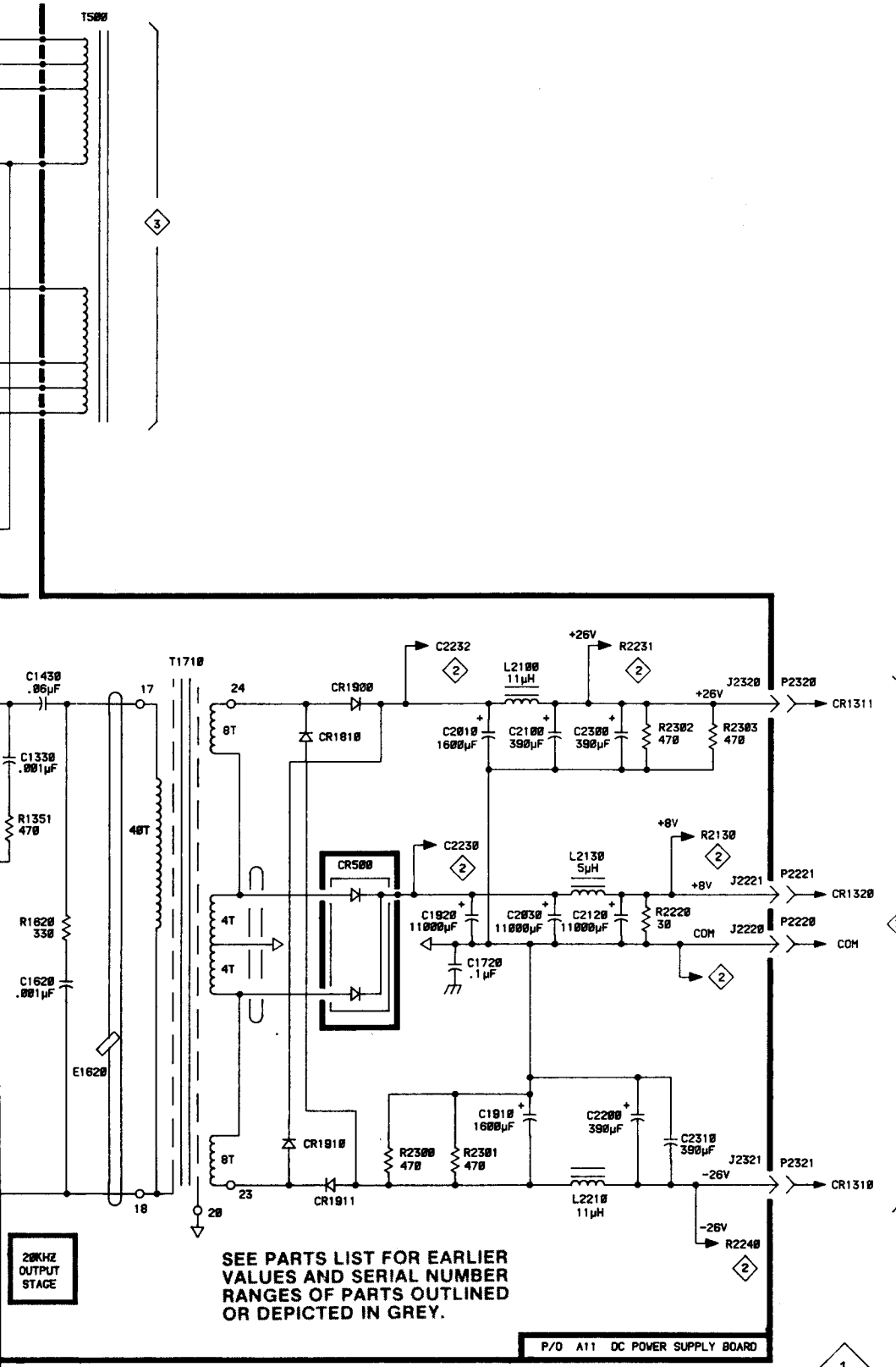

20KHZ
OUTPUT
STAGE

SEE PARTS LIST FOR EARLIER
VALUES AND SERIAL NUMBER
RANGES OF PARTS OUTLINED
OR DEPICTED IN GREY.

P/O A11 DC POWER SUPPLY BOARD

DC POWER SUPPLY

Static Sensitive Devices
See Maintenance Section

COMPONENT NUMBER EXAMPLE

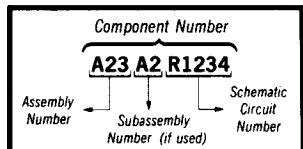

Chassis-mounted components have no Assembly Number prefix—see end of Replaceable Electrical Parts List.

1 JS

Table 8-2 COMPONENT REFERENCE CHART (see Fig. 8-1)

P/O A11 ASSY			DC POWER SUPPLY REGULATOR ◇ 2					
CIRCUIT NUMBER	SCHEMATIC LOCATION	BOARD LOCATION	CIRCUIT NUMBER	SCHEMATIC LOCATION	BOARD LOCATION	CIRCUIT NUMBER	SCHEMATIC LOCATION	BOARD LOCATION
C1840	F7	I5	F2340	B2	N5	R2151	B8	L6
C1930	H5	J4				R2230	B4	M4
C1940	H6	J5	J2330	A1	N4	R2231	B4	M4
C1960	B6	J7	J2330	J2	N4	R2232	J2	M7
C1961	C6	J7				R2233	B7	M4
C1965	D6	J7	P2330	A1	N4	R2240	D4	L5
C2040	K5	K5	P2330	J2	N4	R2241*	C2	M5
C2050	K5	K6				R2242	E3	L5
C2051	K6	K6	Q1730	M3	H4	R2243	D2	M5
C2052	H5	K6	Q1731	M2	H4	R2244	B8	L5
C2060	K6	K6	Q2240	D2	M5	R2250	D2	M5
C2065	D7	J7	R1830	M3	I4	R2251	F2	M6
C2066	E6	K7	R1831	M1	I4	R2340*	C2	M5
C2140	C8	K5	R1832	J1	I4	R2342*	C2	M5
C2150	C8	L6	R1850*	E7	I5	R2343	F2	M5
C2151	E2	L6	R1851	F7	I6	R2350	B3	N6
C2160	J2	L7	R1852*	H7	I6	R2351	C3	N6
C2230	B7	M4	R1855*	H7	I6	R2352	D3	L7
C2231	B7	M4	R1860	E5	I7	R2360	H4	N7
C2232	B6	M4	R1930	K4	J4			
C2240	F2	M5	R1931	H4	J4	U1840A	E7	I5
C2260	C1	M7	R1950	J1	I6	U1840B	E7	I5
C2350*	B2	M5	R1951	M2	I6	U1840C	F7	I5
			R1952	H6	J6	U1840D	J6	I5
CR1730	M3	H4	R1953	J6	J6	U1840E	L3	I5
CR1731	M1	H4	R1960	E8	J6	U1840F	L2	I5
CR1850	F7	I6	R1961	D6	J7	U1940A	H5	J5
CR1950	F6	J6	R1962	D5	J7	U1940B	L7	J5
CR2040	K5	K5	R1963	C6	J7	U1950A	L1	I5
CR2041	K6	K5	R2040	F5	K5	U1950B	L3	I5
CR2042	E6	K5	R2041	F5	K5	U1951A	M7	J6
CR2043	K5	K5	R2042	D5	K5	U1951B	M4	J6
CR2130	E3	K4	R2050	C6	K6	U2140		L5
CR2149	D7	L5	R2060	K7	K6	U2140A	E8	L5
CR2150	J5	K6	R2061	K5	K7	U2140B	F5	L5
CR2230	C4	L5	R2063	E5	K7	U2140C	E4	L5
CR2240	C4	L5	R2064	E6	K7	U2140D	F4	L5
CR2340	B1	N5	R2130	B4	M4	U2160	H2	L7
CR2341	C1	N5	R2132	C4	L4	U2250	E2	M6
CR2349	F1	M6	R2133	E4	L4			
CR2350	C3	N6	R2140	D7	K5	VR2342*	C2	M5
CR2351	D3	N7	R2141	E3	L5			
CR2360	F3	L7	R2150	B8	L6	W1860*	E7	I7

P/O A11 ASSY also shown on ◇ 1

*See Parts List for
serial number ranges.

REV NOV 1984

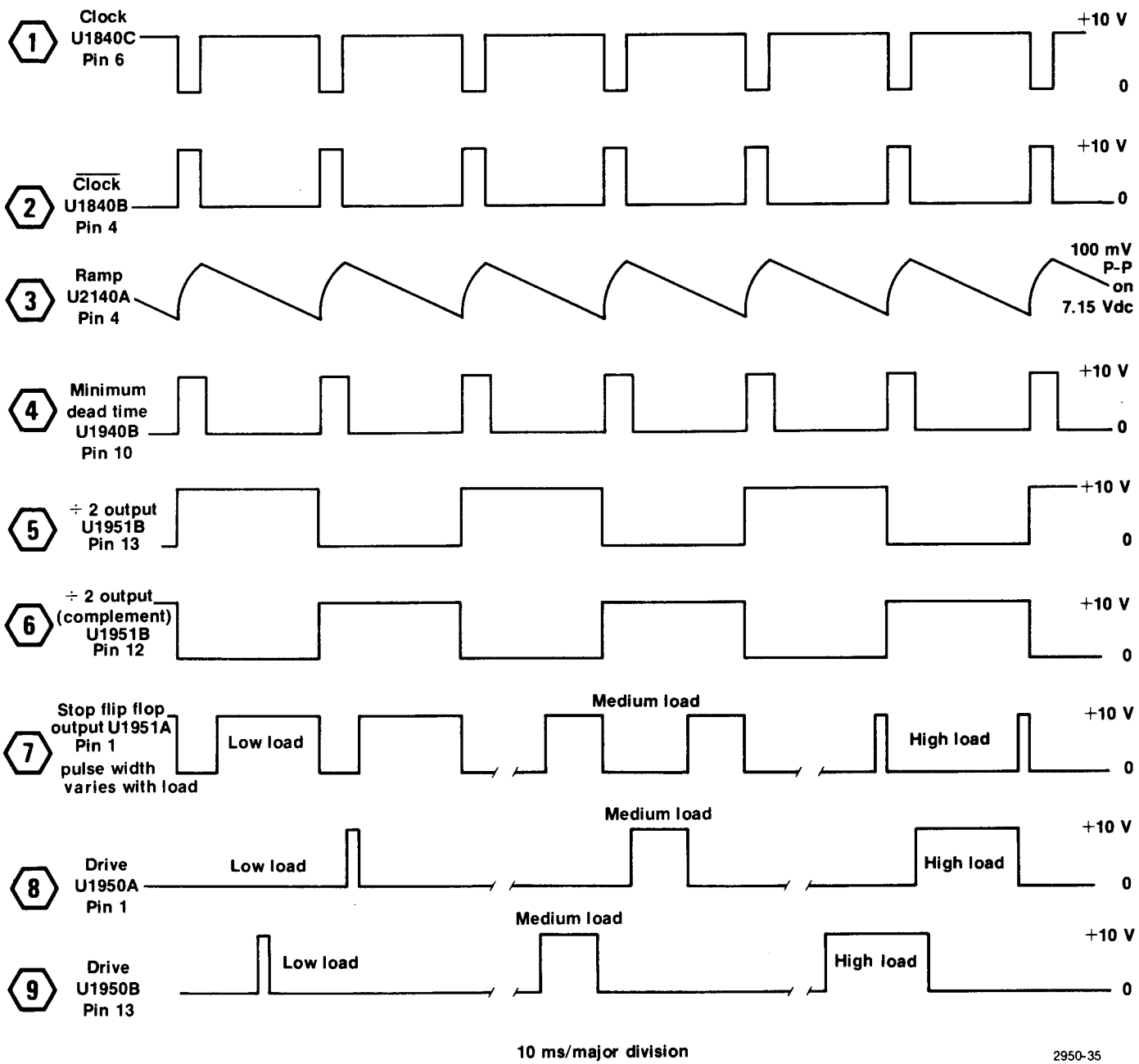
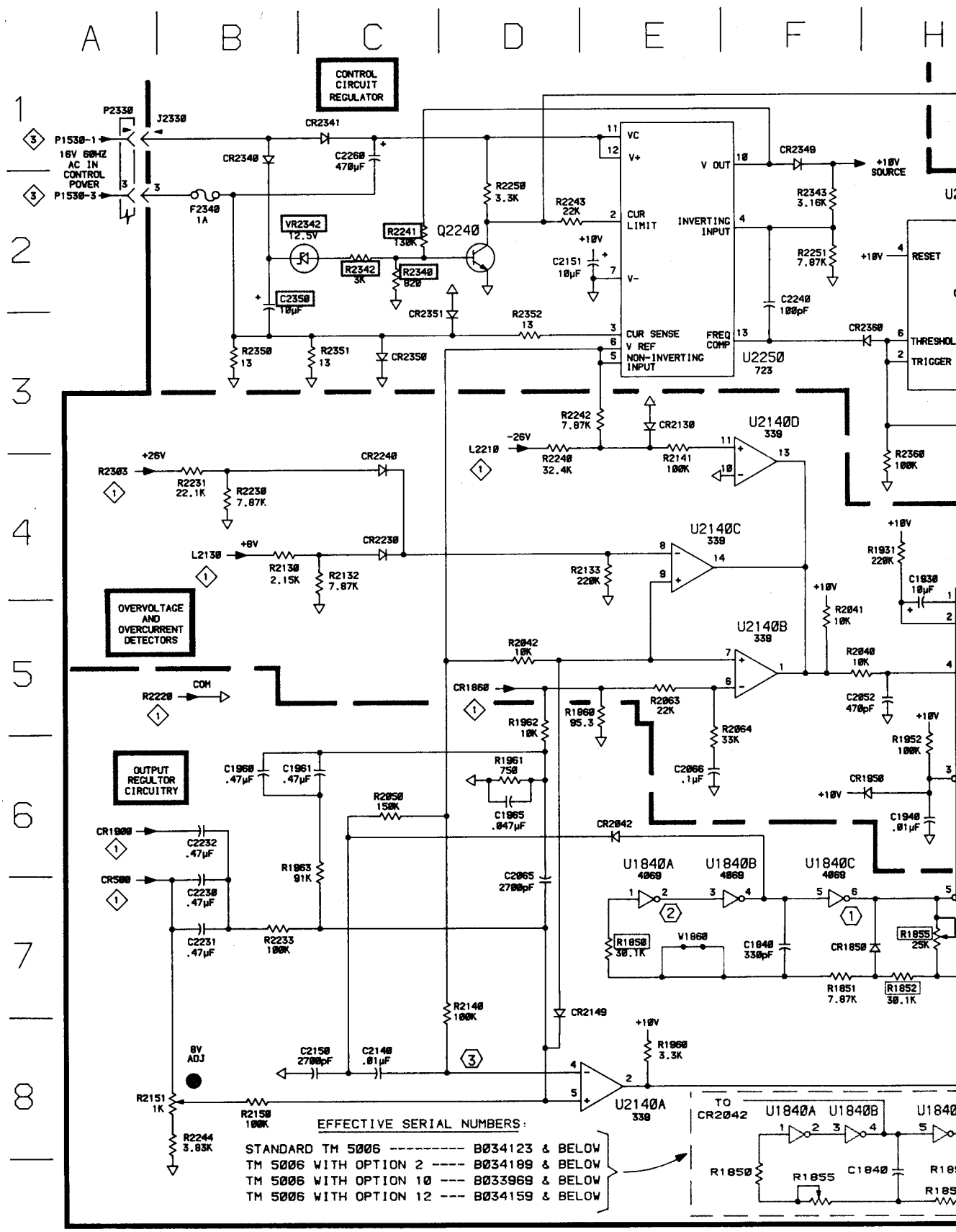

Fig. 8-2. Dc Power Supply Regulator Waveforms.



EFFECTIVE SERIAL NUMBERS:

STANDARD TM 5006	-----	B034123 & BELOW
TM 5006 WITH OPTION 2	-----	B034189 & BELOW
TM 5006 WITH OPTION 10	-----	B033969 & BELOW
TM 5006 WITH OPTION 12	-----	B034159 & BELOW

TM 5006

2950-41
REV NOV 1984

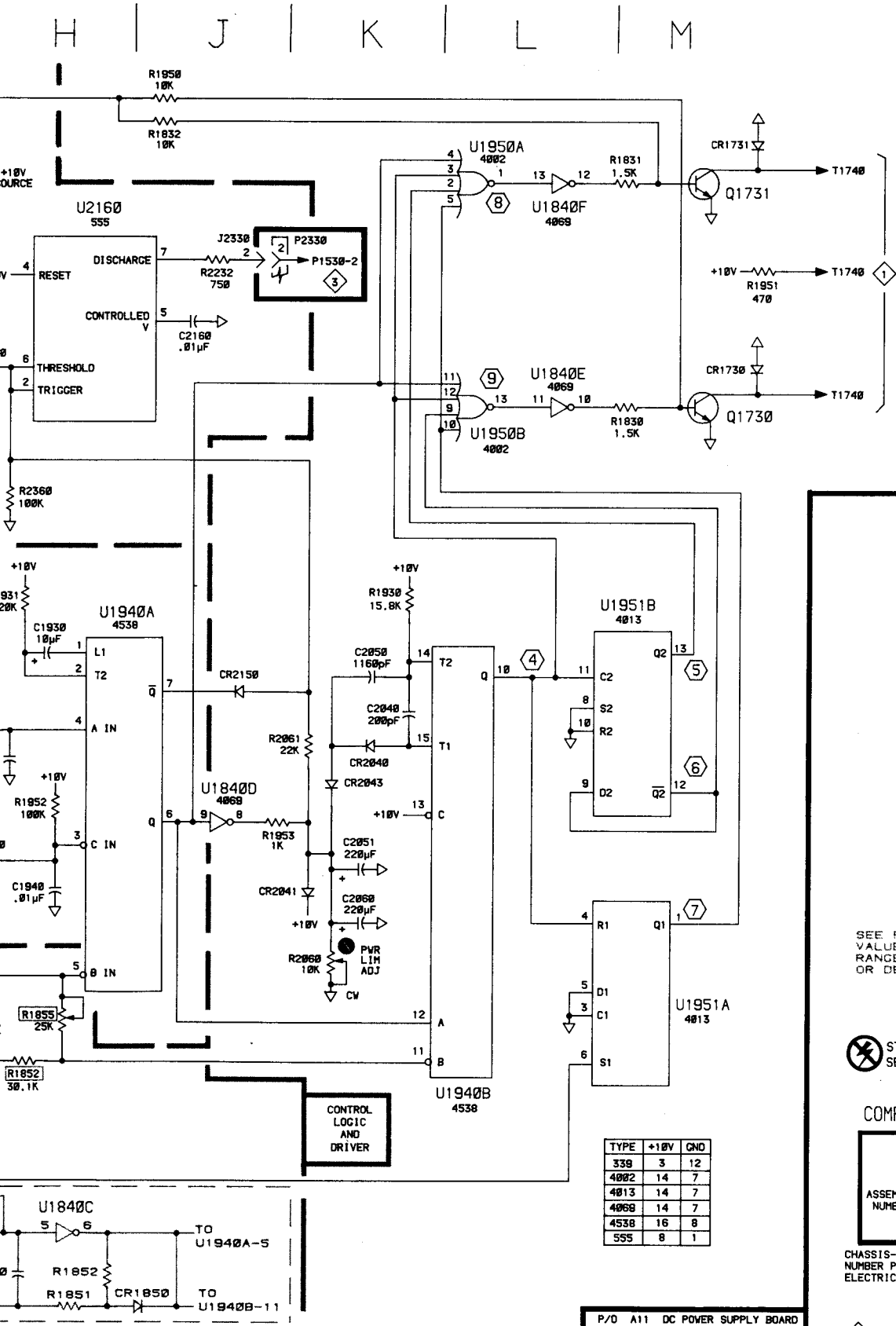

SEE PARTS LIST FOR EARLIER VALUES AND SERIAL NUMBER RANGES OF PARTS OUTLINED OR DEPICTED IN GREY

STATIC SENSITIVE DEVICES SEE MAINTENANCE SECTION

COMPONENT NUMBER EXAMPLE

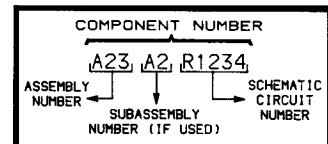

CHASSIS-MOUNTED COMPONENTS HAVE NO ASSEMBLY NUMBER PREFIX—SEE END OF REPLACEABLE ELECTRICAL PARTS LIST

TYPE	+10V	GND
339	3	12
4002	14	7
4013	14	7
4069	14	7
4538	16	8
555	8	1

DC POWER SUPPLY REGULATOR

PARTS LOCATION

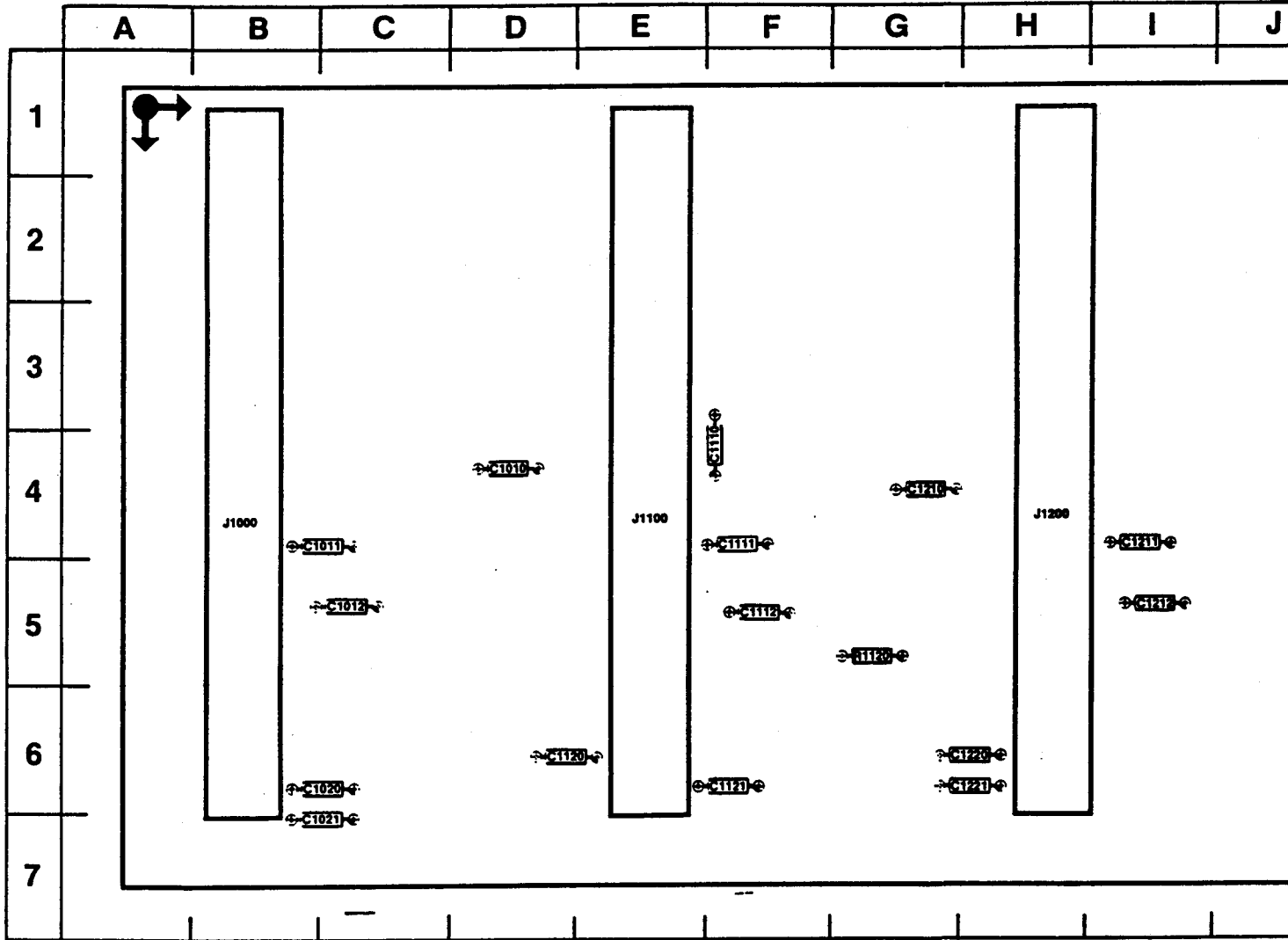

COMPONENT NUMBER EXAMPLE

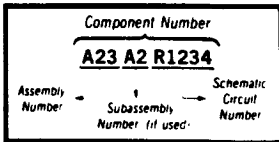

Chassis-mounted components have no Assembly Number prefix—see end of Replacable Electrical Parts List

 Static Sensitive Devices
See Maintenance Section

Fig. 8-3. Main Interface

LOCATION GRID

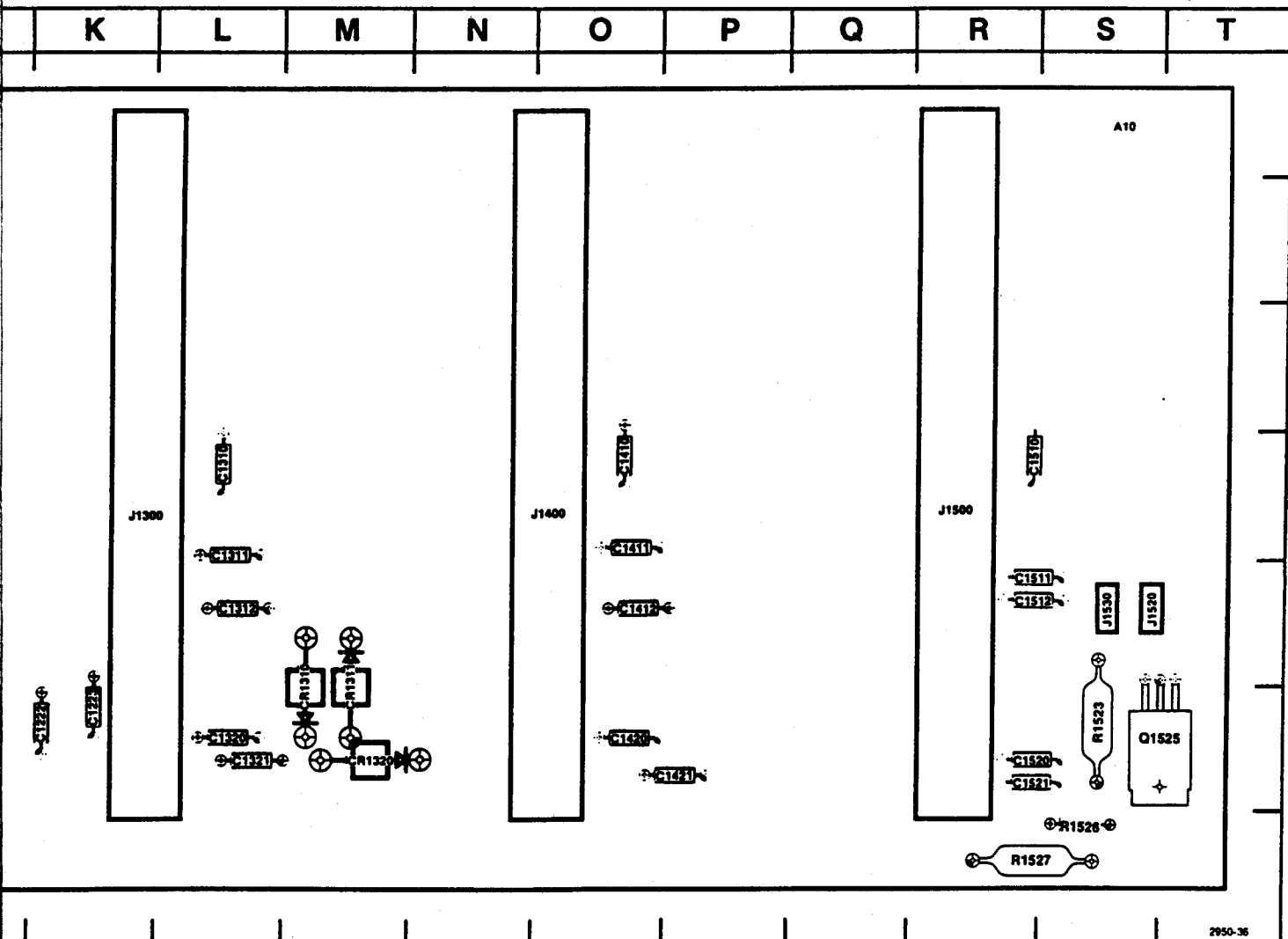

2950-36
ASSY A10

board (Assy A10).

Table 8-3 COMPONENT REFERENCE CHART

A10 ASSY			MAIN INTERFACE 3		
CIRCUIT NUMBER	SCHEMATIC LOCATION	BOARD LOCATION	CIRCUIT NUMBER	SCHEMATIC LOCATION	BOARD LOCATION
C1010	M5	D4	J1520	H9	S5
C1011	M5	C4	J1530	P9	S5
C1012	M6	C5	J1530	B8	S5
C1020	P8	C6			
C1021	M9	C7	P1520	H9	S5
C1110	L4	F4	P1530	B8	S5
C1111	K5	F4	P1530	P9	S5
C1112	L6	F5			
C1120	M8	D6	Q1525	M9	P6
C1121	L9	F6			
C1210	J4	G4	R1120	H6	G5
C1211	H5	I4	R1523	M9	P6
C1212	H6	I5	R1526	M9	P7
C1220	K8	H6	R1527	M9	P7
C1221	J9	H6			
C1222	C8	K6	E500	P7	Chassis
C1223	C7	K6			
C1310	G4	L4	P500	C5	Chassis
C1311	H5	L4	P510	C7	Chassis
C1312	H6	L5	P520	E5	Chassis
C1320	H8	L6	P530	E7	Chassis
C1321	F9	L6	P540	G5	Chassis
C1410	E3	O4	P550	G7	Chassis
C1411	F5	O4	P560	J5	Chassis
C1412	F6	O5	P570	J7	Chassis
C1420	F8	O6	P580	L5	Chassis
C1421	E9	P6	P590	L7	Chassis
C1510	C3	R4			
C1511	D5	R5	Q500	C5	Chassis
C1512	D6	R5	Q510	C7	Chassis
C1520	D8	R6	Q520	D5	Chassis
C1521	C9	R6	Q530	D7	Chassis
			Q540	F5	Chassis
CR1310	N2	M5	Q550	F7	Chassis
CR1311	N1	M5	Q560	J5	Chassis
CR1320	N2	M6	Q570	J7	Chassis
			Q580	L5	Chassis
J1000	N3	B4	Q590	L7	Chassis
J1100	L2	E4	Q600	M5	Chassis
J1200	K3	H4	Q610	M7	Chassis
J1300	G2	K4			
J1400	E1	O4	T500	B3	Chassis
J1500	C1	R4			

A | B | C | D | E | F | G | H |

1
2
3
4
5
6
7
8
9

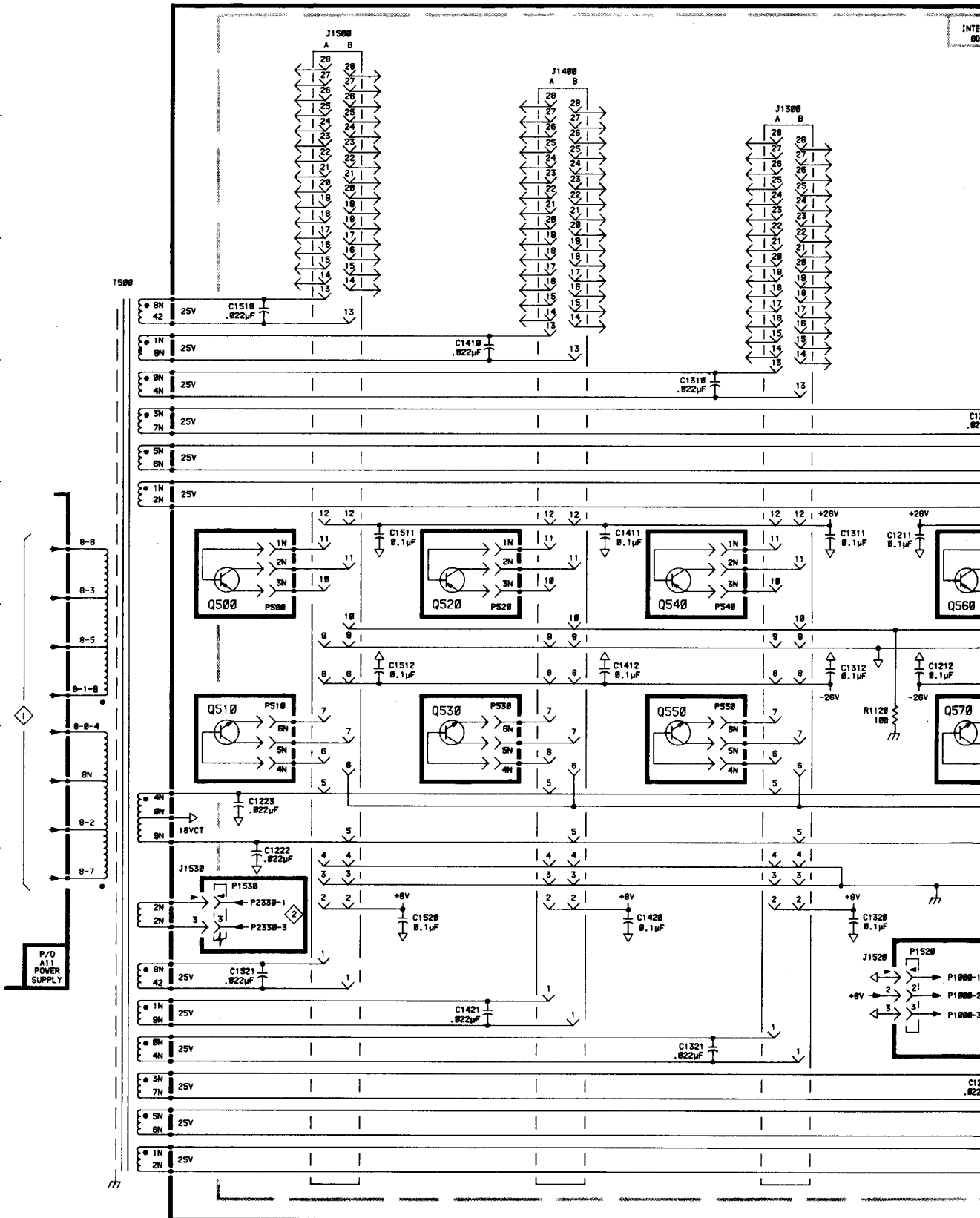

TM 5006

2958-42

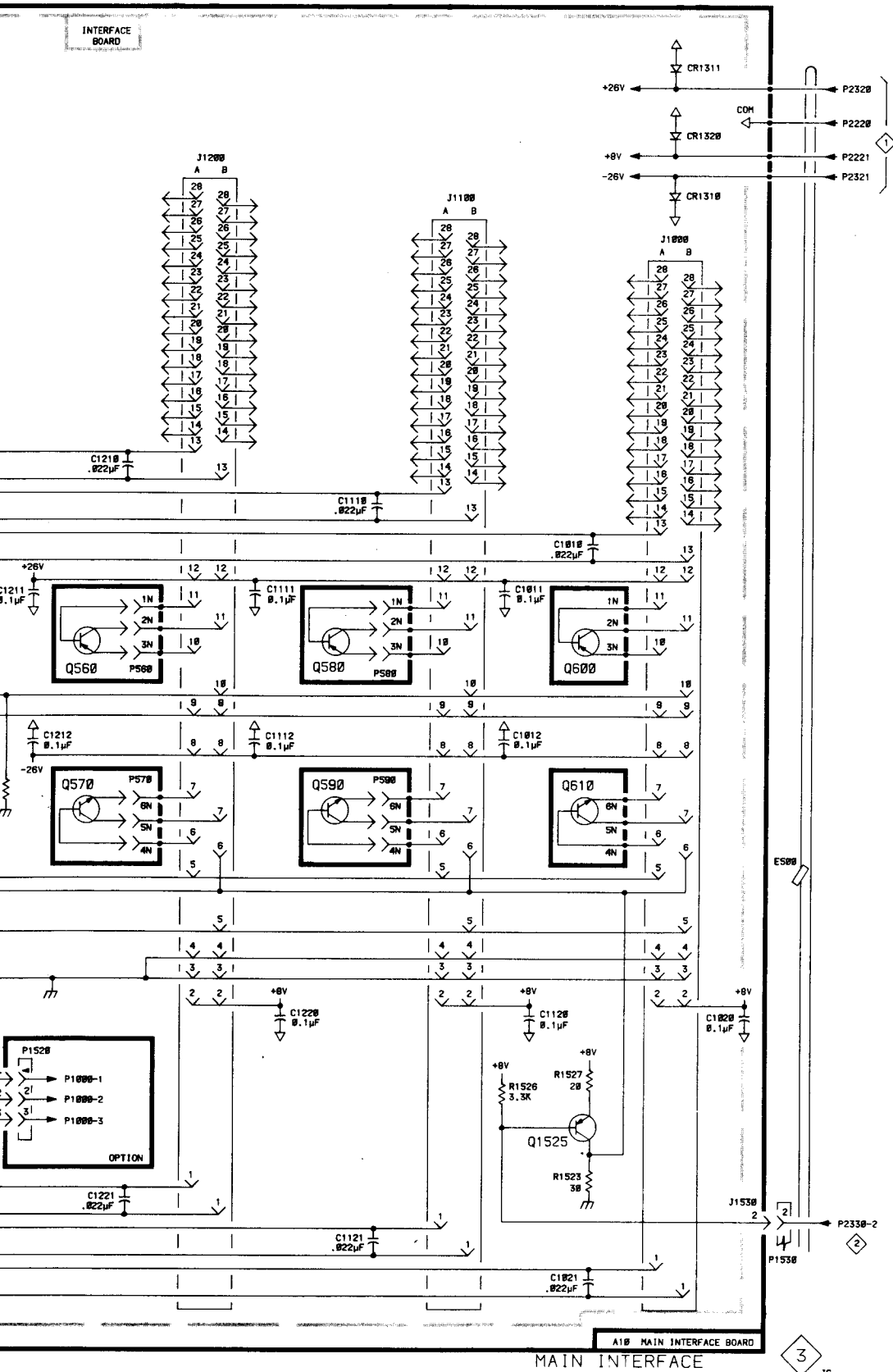

Static Sensitive Devices
See Maintenance Section

COMPONENT NUMBER EXAMPLE

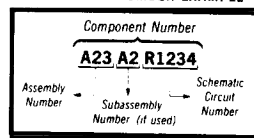

Chassis-mounted components have no Assembly Number prefix—see end of Replaceable Electrical Parts List

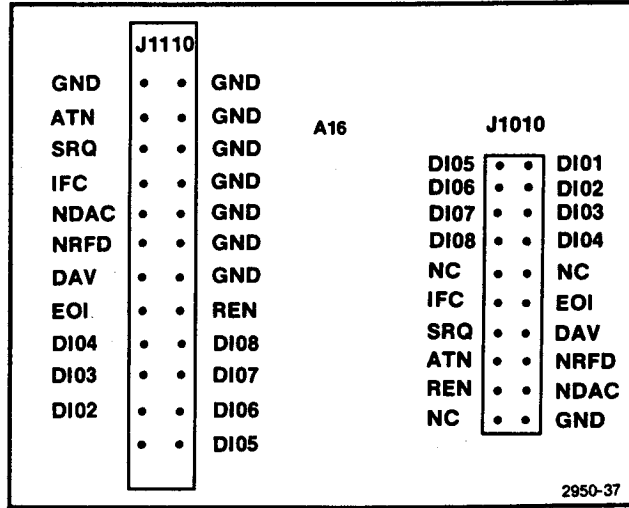
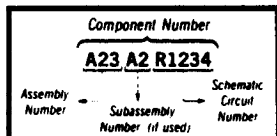

Fig. 8-4. GPIB Interconnect Board (backside) (Assy A16).

 Static Sensitive Devices
See Maintenance Section

COMPONENT NUMBER EXAMPLE



Chassis-mounted components have no Assembly Number prefix—see end of Replaceable Electrical Parts List

@

A | B | C | D | E | F |

1
—
2
—
3
—
4
—
5
—
6
—
7
—
8
—

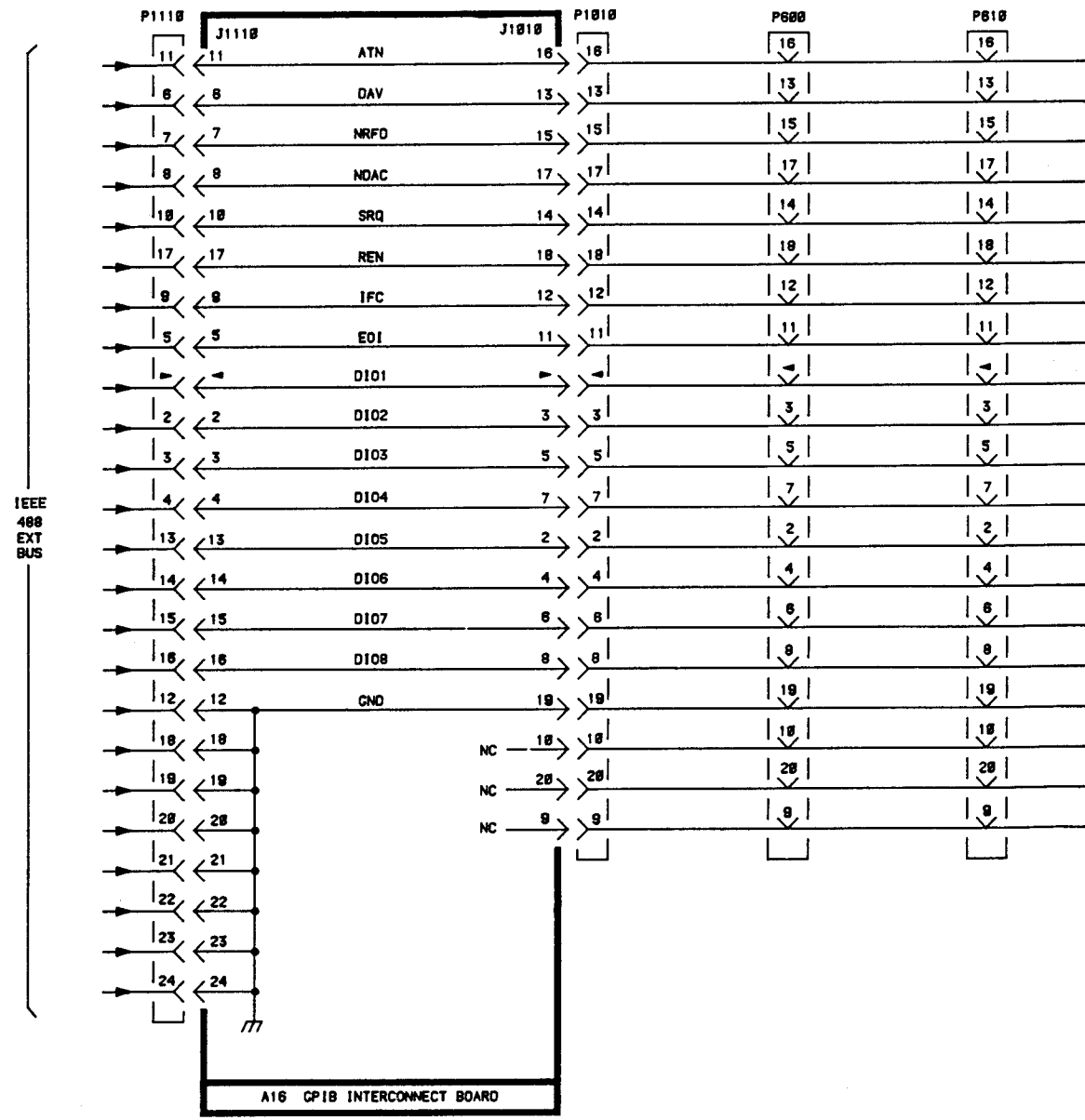

TM 5006

©
2858-43



| H | J | K | L | M

P610	P620	P630	P640	P650
16	16	16	16	16
13	13	13	13	13
15	15	15	15	15
17	17	17	17	17
14	14	14	14	14
18	18	18	18	18
12	12	12	12	12
11	11	11	11	11
4	4	4	4	4
3	3	3	3	3
5	5	5	5	5
7	7	7	7	7
2	2	2	2	2
4	4	4	4	4
6	6	6	6	6
8	8	8	8	8
19	19	19	19	19
18	18	18	18	18
20	20	20	20	20
9	9	9	9	9

 **Static Sensitive Devices**
See Maintenance Section

COMPONENT NUMBER EXAMPLE

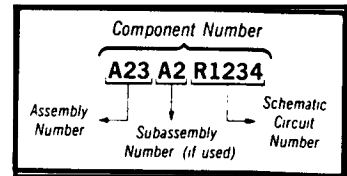

Chassis-mounted components have no Assembly Number prefix—see end of Replaceable Electrical Parts List.

GPIB INTERCONNECT



JS

A10 MAIN INTERFACE BOARD CUSTOM

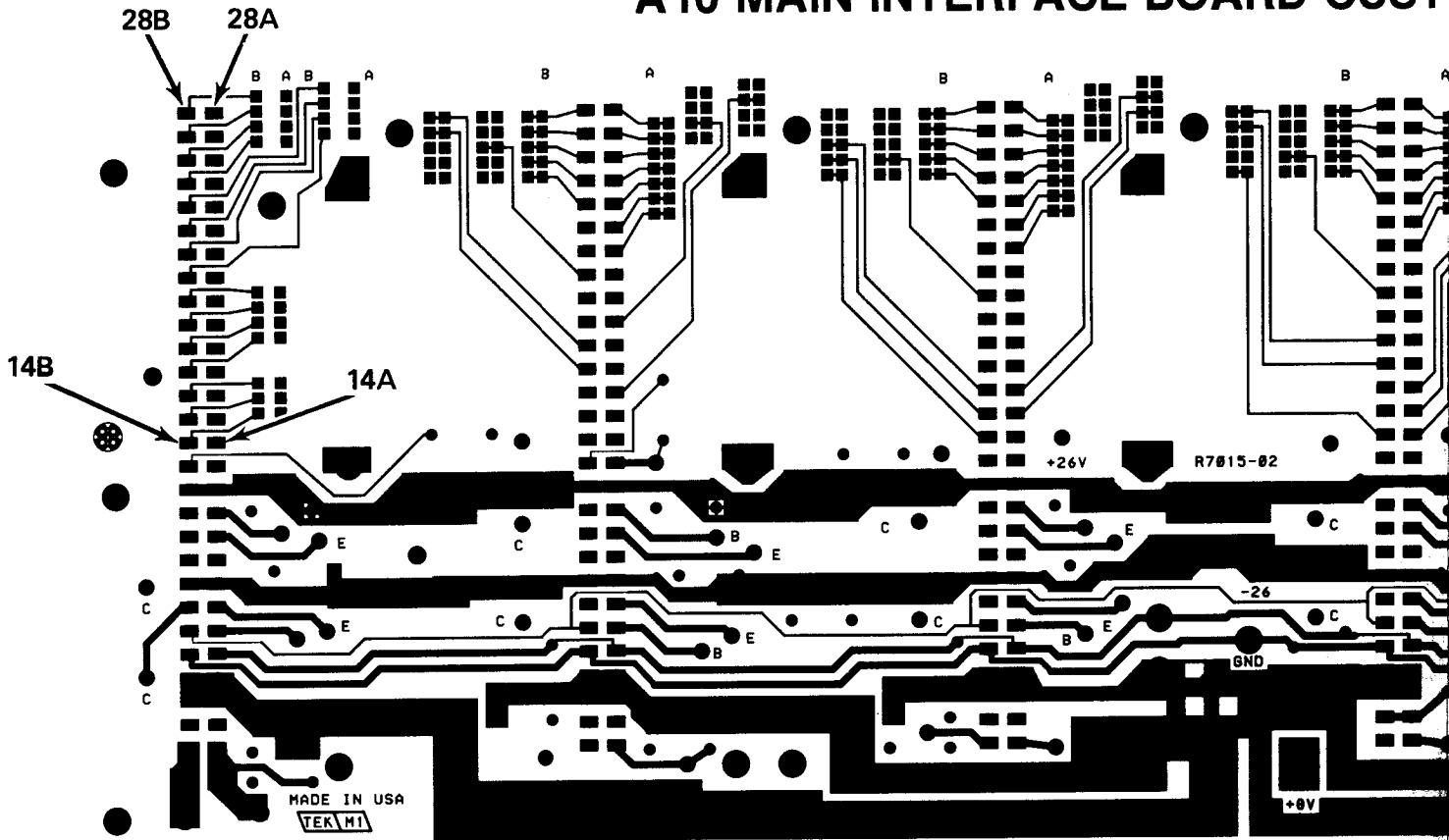

Fig. 8-5. Main Interface Board (backside, A

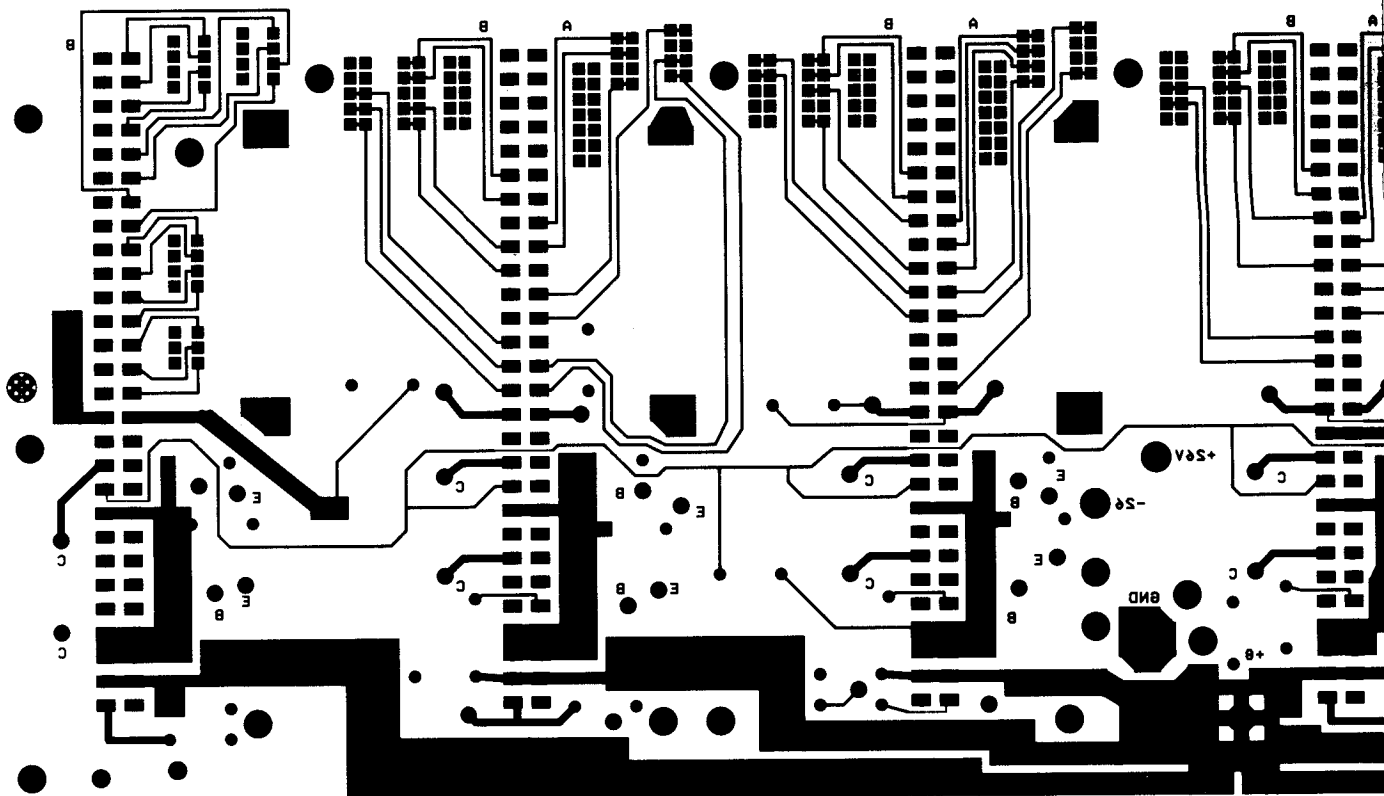
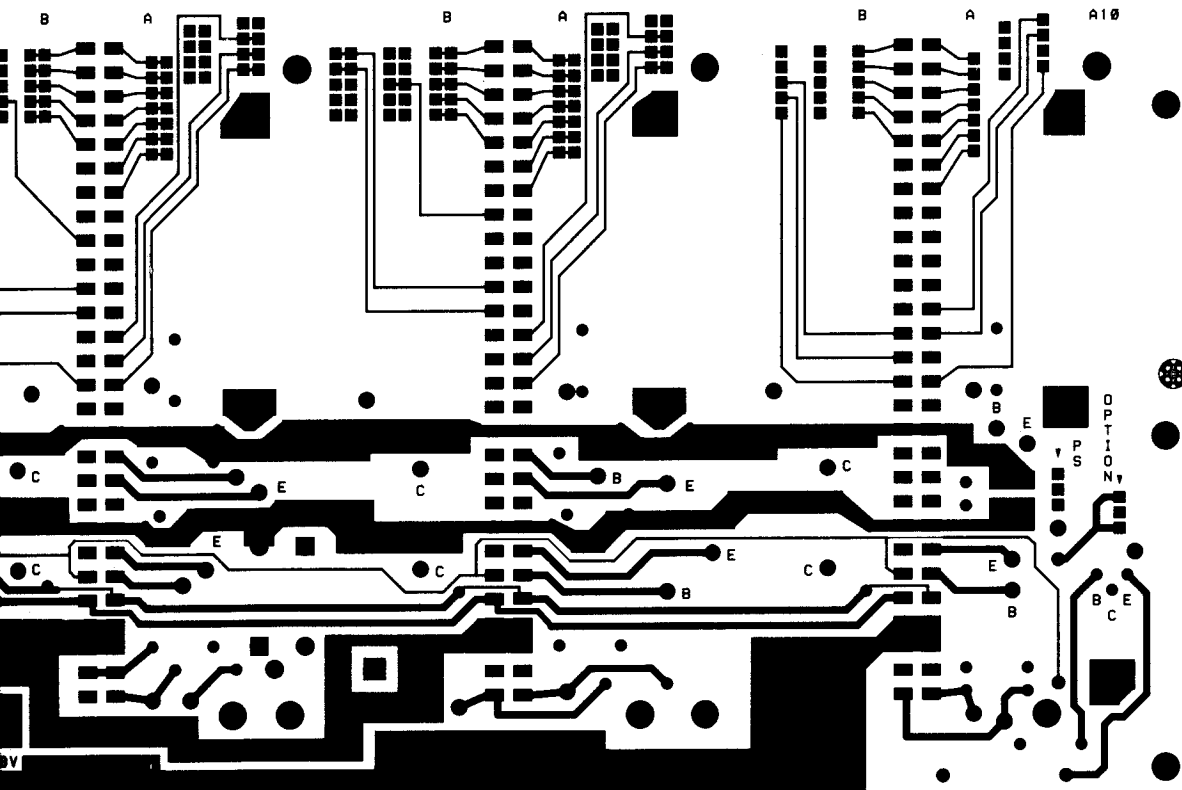
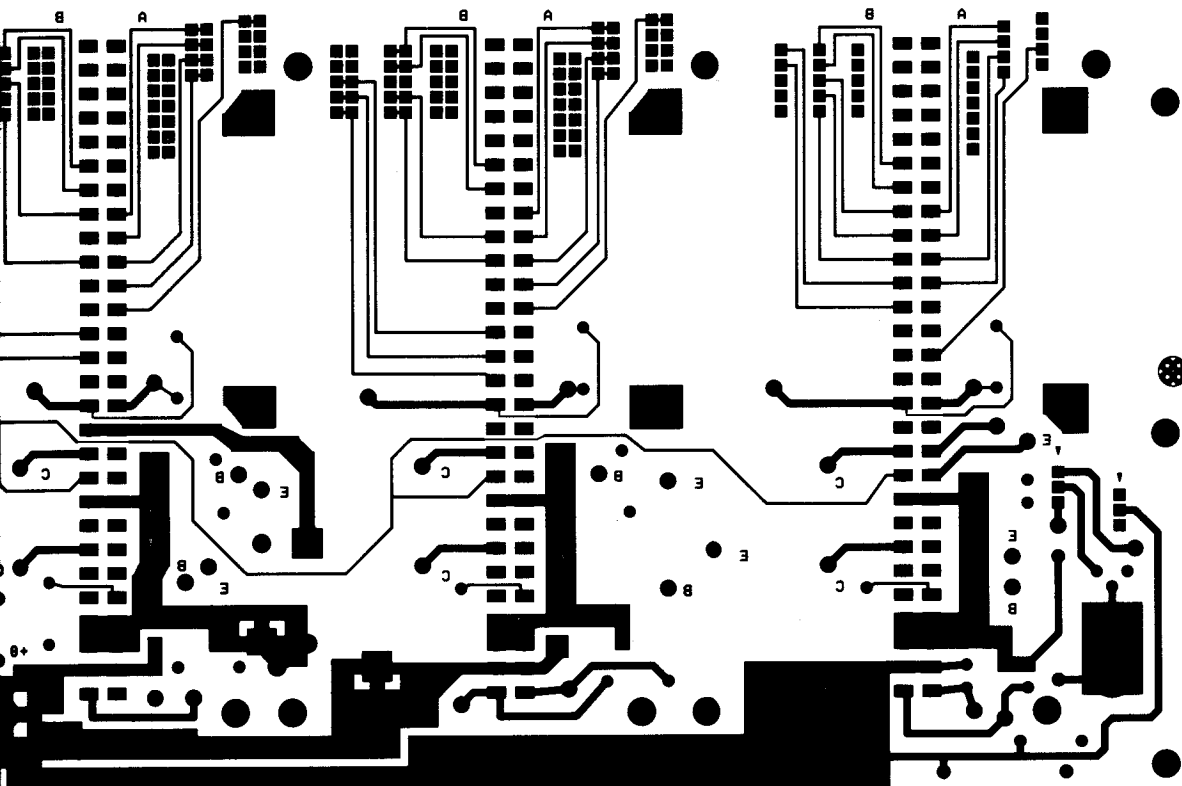

Fig. 8-6. Main Interface Board (rear view of front

CUSTOM INTERFACING AID



rd (backside, Assy A10).



ar view of frontside, Assy A10).

ADD NOV 1984

THIS ART IS PROVIDED AS AN AID FOR
CUSTOM INTERFACE WIRING, SUCH AS
OPT. 02.

REPLACEABLE MECHANICAL PARTS

PARTS ORDERING INFORMATION

Replacement parts are available from or through your local Tektronix, Inc. Field Office or representative.

Changes to Tektronix instruments are sometimes made to accommodate improved components as they become available, and to give you the benefit of the latest circuit improvements developed in our engineering department. It is therefore important, when ordering parts, to include the following information in your order: Part number, instrument type or number, serial number, and modification number if applicable.

If a part you have ordered has been replaced with a new or improved part, your local Tektronix, Inc. Field Office or representative will contact you concerning any change in part number.

Change information, if any, is located at the rear of this manual.

SPECIAL NOTES AND SYMBOLS

- X000 Part first added at this serial number
- 00X Part removed after this serial number

FIGURE AND INDEX NUMBERS

Items in this section are referenced by figure and index numbers to the illustrations.

INDENTATION SYSTEM

This mechanical parts list is indented to indicate item relationships. Following is an example of the indentation system used in the description column.

- ```

1 2 3 4 5 Name & Description
Assembly and/or Component
Attaching parts for Assembly and/or Component

Detail Part of Assembly and/or Component
Attaching parts for Detail Part

Parts of Detail Part
Attaching parts for Parts of Detail Part

```

Attaching Parts always appear in the same indentation as the item it mounts, while the detail parts are indented to the right. Indented items are part of, and included with, the next higher indentation. The separation symbol --- \* --- indicates the end of attaching parts.

**Attaching parts must be purchased separately, unless otherwise specified.**

## ITEM NAME

In the Parts List, an Item Name is separated from the description by a colon (:). Because of space limitations, an Item Name may sometimes appear as incomplete. For further Item Name identification, the U.S. Federal Cataloging Handbook H6-1 can be utilized where possible.

## ABBREVIATIONS

|       |                    |         |                       |          |                      |          |                 |
|-------|--------------------|---------|-----------------------|----------|----------------------|----------|-----------------|
| #     | INCH               | ELCTRN  | ELECTRON              | IN       | INCH                 | SE       | SINGLE END      |
| ACTR  | NUMBER SIZE        | ELEC    | ELECTRICAL            | INCAND   | INCANDESCENT         | SECT     | SECTION         |
| ADPTR | ACTUATOR           | ELCTLT  | ELECTROLYTIC          | INSUL    | INSULATOR            | SEMICOND | SEMICONDUCTOR   |
| ALIGN | ADAPTER            | ELEM    | ELEMENT               | INTL     | INTERNAL             | SHLD     | SHIELD          |
| AL    | ALIGNMENT          | EPL     | ELECTRICAL PARTS LIST | LPHLDR   | LAMPHOLDER           | SHLDR    | SHOULDERED      |
| ASSEM | ALUMINUM           | EQPT    | EQUIPMENT             | MACH     | MACHINE              | SKT      | SOCKET          |
| ASSY  | ASSEMBLED          | EXT     | EXTERNAL              | MECH     | MECHANICAL           | SL       | SLIDE           |
| ATTEN | ASSEMBLY           | FIL     | FILLISTER HEAD        | MTG      | MOUNTING             | SLFLKG   | SELF-LOCKING    |
| AWG   | ATTENUATOR         | FLEX    | FLEXIBLE              | NIP      | NIPPLE               | SLVG     | SLEEVING        |
| BD    | AMERICAN WIRE GAGE | FLH     | FLAT HEAD             | NON WIRE | NOT WIRE WOUND       | SPR      | SPRING          |
| BRKT  | BOARD              | FLTR    | FILTER HEAD           | OBD      | ORDER BY DESCRIPTION | SQ       | SQUARE          |
| BRS   | BRACKET            | FR      | FRAME or FRONT        | OD       | OUTSIDE DIAMETER     | SST      | STAINLESS STEEL |
| BRZ   | BRASS              | FSTNR   | FASTENER              | OVH      | OVAL HEAD            | STL      | STEEL           |
| BSHG  | BRONZE             | FT      | FOOT                  | PH BRZ   | PHOSPHOR BRONZE      | SW       | SWITCH          |
| CAB   | BUSHING            | FXD     | FIXED                 | PL       | PLAIN or PLATE       | T        | TUBE            |
| CAP   | CABINET            | GSKT    | GASKET                | PLSTC    | PLASTIC              | TERM     | TERMINAL        |
| CER   | CAPACITOR          | HDL     | HANDLE                | PN       | PART NUMBER          | THD      | THREAD          |
| CHAS  | CERAMIC            | HEX     | HEXAGON               | PNH      | PAN HEAD             | THK      | THICK           |
| CKT   | CHASSIS            | HEX HD  | HEXAGONAL HEAD        | PWR      | POWER                | TNSN     | TENSION         |
| COMP  | CIRCUIT            | HEX SOC | HEXAGONAL SOCKET      | RCPT     | RECEPTACLE           | TPG      | TAPPING         |
| CONN  | COMPOSITION        | HLCPS   | HELICAL COMPRESSION   | RES      | RESISTOR             | TRH      | TRUSS HEAD      |
| COV   | CONNECTOR          | HLEXT   | HELICAL EXTENSION     | RGD      | RIGID                | V        | VOLTAGE         |
| CPLG  | COVER              | HV      | HIGH VOLTAGE          | RLF      | RELIEF               | VAR      | VARIABLE        |
| CRT   | COUPLING           | IC      | INTEGRATED CIRCUIT    | RTNR     | RETAINER             | W/       | WITH            |
| DEG   | CATHODE RAY TUBE   | ID      | INSIDE DIAMETER       | SCH      | SOCKET HEAD          | WSHR     | WASHER          |
| DWR   | DEGREE             | IDNT    | IDENTIFICATION        | SCOPE    | OSCILLOSCOPE         | XFMR     | TRANSFORMER     |
|       | DRAWER             | IMPLR   | IMPELLER              | SCR      | SCREW                | XSTR     | TRANSISTOR      |



CROSS INDEX - MFR. CODE NUMBER TO MANUFACTURER

| Mfr. Code | Manufacturer                                                                                  | Address                                            | City, State, Zip Code         |
|-----------|-----------------------------------------------------------------------------------------------|----------------------------------------------------|-------------------------------|
| 00779     | AMP INC                                                                                       | P O BOX 3608                                       | HARRISBURG PA 17105           |
| 02114     | AMPEREX ELECTRONIC CORP<br>FERROXCUBE DIV                                                     | 5083 KINGS HWY                                     | SAUGERTIES NY 12477           |
| 02735     | RCA CORP<br>SOLID STATE DIVISION                                                              | ROUTE 202                                          | SOMERVILLE NJ 08876           |
| 06666     | GENERAL DEVICES CO INC                                                                        | 1410 S POST RD<br>P O BOX 39100                    | INDIANAPOLIS IN 46239         |
| 06915     | RICHCO PLASTIC CO                                                                             | 5825 N TRIPP AVE                                   | CHICAGO IL 60646              |
| 09922     | BURNDY CORP                                                                                   | RICHARDS AVE                                       | NORWALK CT 06852              |
| 12327     | FREEWAY CORP                                                                                  | 9301 ALLEN DR                                      | CLEVELAND OH 44125            |
| 13511     | AMPHENOL CADRE DIV BUNKER RAMO CORP                                                           |                                                    | LOS GATOS CA                  |
| 16037     | SPRUCE PINE MICA CO.                                                                          | P. O. BOX 219                                      | SPRUCE PINE, NC 28777         |
| 16428     | BELDEN CORP<br>ELECTRONIC DIV                                                                 | 2200 US HWY 27 SOUTH<br>P O BOX 1980               | RICHMOND IN 47374             |
| 22526     | DU PONT E I DE NEMOURS AND CO INC<br>DU PONT CONNECTOR SYSTEMS<br>DIV MILITARY PRODUCTS GROUP | 515 FISHING CREEK RD                               | NEW CUMBERLAND PA 17070-3007  |
| 24618     | TRANSCON MFG. CO.                                                                             | 2655 PERTH ST.                                     | DALLAS, TX 75220              |
| 27264     | MOLEX INC<br>CORPORATE HQ                                                                     | 2222 WELLINGTON COURT                              | LISLE IL 60532                |
| 70485     | ATLANTIC INDIA RUBBER WORKS INC                                                               | 571 W POLK ST                                      | CHICAGO IL 60607              |
| 70903     | BELDEN CORP                                                                                   | 2000 S BATAVIA AVE                                 | GENEVA IL 60134               |
| 71468     | ITT CANNON ELECTRIC                                                                           | 10550 TALBERT<br>PO BOX 8040                       | FOUNTAIN VALLEY CA 92728-8040 |
| 73743     | FISCHER SPECIAL MFG CO                                                                        | 446 MORGAN ST                                      | CINCINNATI OH 45206           |
| 77900     | SHAKEPROOF<br>DIV OF ILLINOIS TOOL WORKS                                                      | SAINT CHARLES RD                                   | ELGIN IL 60120                |
| 78189     | ILLINOIS TOOL WORKS INC<br>SHAKEPROOF DIVISION                                                | ST CHARLES ROAD                                    | ELGIN IL 60120                |
| 79136     | WALDES KOHINOOR INC                                                                           | 47-16 AUSTEL PLACE                                 | LONG ISLAND CITY NY 11101     |
| 80009     | TEKTRONIX INC                                                                                 | 4900 S W GRIFFITH DR<br>P O BOX 500<br>P O BOX 287 | BEAVERTON OR 97077            |
| 81041     | HOWARD INDUSTRIES DIV OF MSL<br>INDUSTRIES INC                                                |                                                    | MILFORD IL 60953              |
| 83385     | MICRODOT MANUFACTURING INC<br>GREER-CENTRAL DIV                                               | 3221 W BIG BEAVER RD                               | TROY MI 48098                 |
| 83486     | ELCO INDUSTRIES INC                                                                           | 1101 SAMUELSON RD                                  | ROCKFORD IL 61101             |
| 85471     | BOYD INDUSTRIAL RUBBER<br>DIV OF A B BOYD CO                                                  | 2527 GRANT AVE                                     | SAN LEANDRO CA 94579          |
| 86928     | SEASTROM MFG CO INC                                                                           | 701 SONORA AVE                                     | GLENDALE CA 91201             |
| 88245     | WINCHESTER ELECTRONICS<br>LITTON SYSTEMS-USECO DIV                                            | 13536 SATICOY ST                                   | VAN NUYS CA 91409             |
| 93907     | TEXTRON INC<br>CAMCAR DIV                                                                     | 600 18TH AVE                                       | ROCKFORD IL 61101             |
| 95987     | WECKESSER CO INC                                                                              | 4444 WEST IRVING PARK RD                           | CHICAGO IL 60641              |
| 98159     | RUBBER TECK, INC.                                                                             | 19115 HAMILTON AVE., P O BOX 389                   | GARDENA, CA 90247             |
| 98410     | ETC DIV OF INTERNATIONAL TELEPHONE<br>AND TELEGRAPH CO                                        | 29000 AURORA RD                                    | SOLOH OH 44139                |
| S3109     | FELLER ASA ADOLF AG<br>C/O PANEL COMPONENTS CORP                                              | 355 TESCONI CIRCLE                                 | SANTA ROSA CA 95401           |
| S3629     | SCHURTER AG H<br>C/O PANEL COMPONENTS CORP                                                    | 2015 SECOND STREET                                 | BERKELEY CA 94170             |
| TK0433    | PORTLAND SCREW CO                                                                             | 6520 N BASIN                                       | PORTLAND OR 97217             |
| TK0435    | LEWIS SCREW CO                                                                                | 4114 S PEORIA                                      | CHICAGO IL 60609              |
| TK0508    | NORTHWEST SPRING AND MFG CO                                                                   | 5858 WILLOW LANE                                   | LAKE OSWEGO OR 97034          |
| TK0858    | STAUFFER SUPPLY CO                                                                            | 105 SE TAYLOR                                      | PORTLAND OR 97214             |
| TK0861    | H SCHURTER AG DIST PANEL COMPONENTS                                                           | 2015 SECOND STREET                                 | BERKELEY CA 94170             |
| TK1373    | PATELEC-CEM (ITALY)                                                                           | 10156 TORINO                                       | VAICENTALLO 62/45S ITALY      |
| TK1569    | GERHART TOOL AND DIE                                                                          | 1116 W ISABEL ST                                   | BURBANK CA 91506              |

| Fig. & Index No. | Tektronix Part No. | Serial/Assembly No. Effective | Dscont  | Qty | 12345 Name & Description                                         | Mfr. Code | Mfr. Part No.  |
|------------------|--------------------|-------------------------------|---------|-----|------------------------------------------------------------------|-----------|----------------|
| 1-1              | 348-0544-05        |                               |         | 4   | RTNR,CAB.COVER:CORNER EARTH BROWN,PC (ATTACHING PARTS)           | 80009     | 348-0544-05    |
| -2               | 213-0782-00        |                               |         | 4   | SCREW,TPG,TF:8-32 X 0.625,FILH,STL (END ATTACHING PARTS)         | 83486     | ORDER BY DESCR |
| -3               | 348-0201-00        |                               |         | 1   | FLIP-STAND,CAB.:2.875 H,SST                                      | TK0508    | (ADVISE)       |
| -4               | 348-0596-00        | B010100                       | B022159 | 4   | PAD,CAB.FOOT:0.69 X 0.255 X 0.06,PU                              | 80009     | 348-0596-00    |
|                  | 348-0776-00        | B022160                       |         | 4   | PAD,CAB.FOOT:POLYURETHANE                                        | 80009     | 348-0776-00    |
| -5               | 348-0617-04        |                               |         | 4   | FOOT,CABINET:BOT,EARTH BROWN,POLYCARBONATE                       | 80009     | 348-0617-04    |
| -6               | 390-0807-00        |                               |         | 1   | CABINET BOTTOM:FULL RACK,17.956                                  | 80009     | 390-0807-00    |
| -7               | 390-0783-03        |                               |         | 1   | CABINET SIDE:7.0 X 17.966,AL,EARTH BROWN SAFETY CONTROLLED       | 80009     | 390-0783-03    |
| -8               | 390-0667-03        |                               |         | 1   | CABINET TOP:FULL RACK X 17.66,AL,EARTH BROW                      | 80009     | 390-0667-03    |
| -9               | 390-0784-07        |                               |         | 1   | CABINET SIDE:7.0 X 17.966,W/HOLES                                | 80009     | 390-0784-07    |
| -10              | 200-2191-03        |                               |         | 2   | CAP,RETAINER:PLASTIC,EARTH BROWN                                 | 80009     | 200-2191-03    |
| -11              | 367-0248-07        |                               |         | 1   | HANDLE,CARRYING:16.34 L,W/CLIP,PLASTIC                           | 80009     | 367-0248-07    |
| -12              | 351-0619-00        |                               |         | 6   | GUIDE,PL-IN UNI:BOTTOM                                           | 80009     | 351-0619-00    |
| -13              | 378-0182-00        |                               |         | 5   | BAFFLE,AIR:                                                      | 80009     | 378-0182-00    |
| -14              | 378-2044-00        |                               |         | 1   | GRILLE,PLASTIC:8.04 L X 0.75 W,SILVER GRAY                       | 80009     | 378-2044-00    |
| -15              | 200-2576-00        |                               |         | 1   | COVER,SWITCH:                                                    | 80009     | 200-2576-00    |
| -16              | -----              |                               |         | 1   | SWITCH,ROCKER:(SEE S500 REPL)                                    |           |                |
| -17              | 200-2565-00        |                               |         | 1   | COVER,SWITCH:PLASTIC                                             | 80009     | 200-2565-00    |
| -18              | 334-0094-00        |                               |         | 1   | EMBLEM:SMOKE TAN W/O STUD                                        | 80009     | 334-0094-00    |
| -19              | 426-1706-01        |                               |         | 1   | FR SECT,PLUG-IN:FRONT (ATTACHING PARTS)                          | 80009     | 426-1706-01    |
| -20              | 211-0502-00        |                               |         | 8   | SCREW,MACHINE:6-32 X 0.188,FLH,100 DEG,STL (END ATTACHING PARTS) | TK0435    | ORDER BY DESCR |
| -21              | 124-0354-03        |                               |         | 1   | STRIP,TRIM:CORNER, TOP, EARTH BROWN 17.41 L                      | 80009     | 124-0354-03    |
| -22              | 124-0355-03        |                               |         | 1   | STRIP,TRIM:CORNER, BOT, EARTH BROWN, 13.9L                       | 80009     | 124-0355-03    |
| -23              | 124-0380-01        |                               |         | 1   | STRIP,TRIM:17.41 L,CORNER W/STEP, TOP, EARTH BROWN               | 80009     | 124-0380-01    |
| -24              | 124-0381-01        |                               |         | 1   | STRIP,TRIM:13.91 L,CORNER W/STEP,BOT, EARTH BROWN                | 80009     | 124-0381-01    |
| -25              | 343-0003-00        |                               |         | 2   | CLAMP,LOOP:0.25 ID,PLASTIC (ATTACHING PARTS)                     | 06915     | E4 CLEAR ROUND |
| -26              | 211-0578-00        |                               |         | 2   | SCREW,MACHINE:6-32 X 0.438,PNH,STL                               | TK0435    | ORDER BY DESCR |
| -27              | 210-0457-00        |                               |         | 2   | NUT,PL,ASSEM WA:6-32 X 0.312,STL CD PL                           | 78189     | 511-061800-00  |
| -28              | 210-0863-00        |                               |         | 2   | WSHR,LOOP CLAMP:0.187 ID U/W 0.5 W CLP (END ATTACHING PARTS)     | 95987     | C191           |
| -29              | 426-1480-01        |                               |         | 1   | FRAME,CABINET:REAR,7.0 X FULL RACK (ATTACHING PARTS)             | 80009     | 426-1480-01    |
| -30              | 213-0863-00        |                               |         | 4   | SCREW,TPG,TR:8-32 X 1.375,TAPTITE,FILH,STL (END ATTACHING PARTS) | 93907     | ORDER BY DESCR |
| -31              | 426-1705-00        |                               |         | 4   | FR SECT,PLUG-IN:CORNER                                           | 80009     | 426-1705-00    |

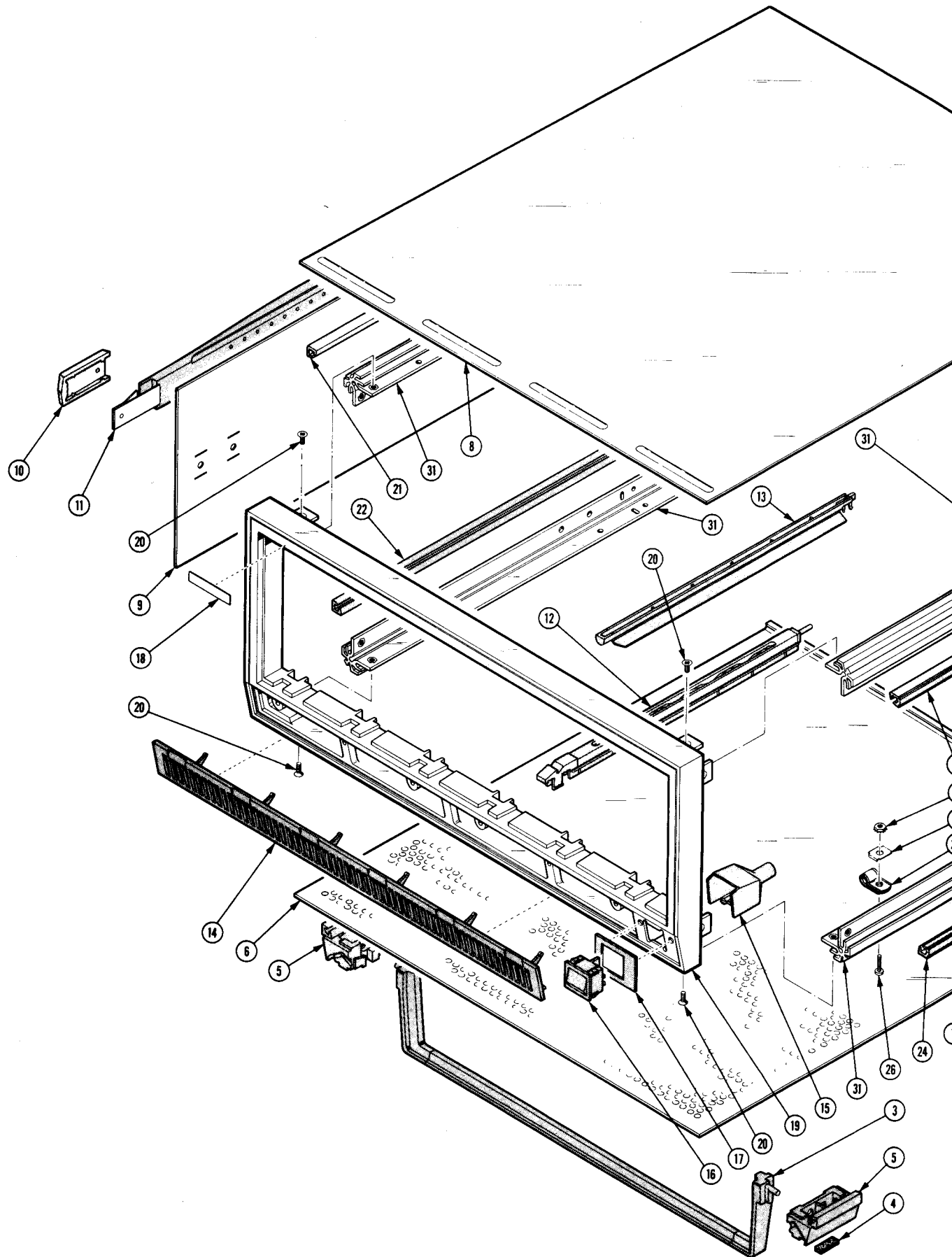

@

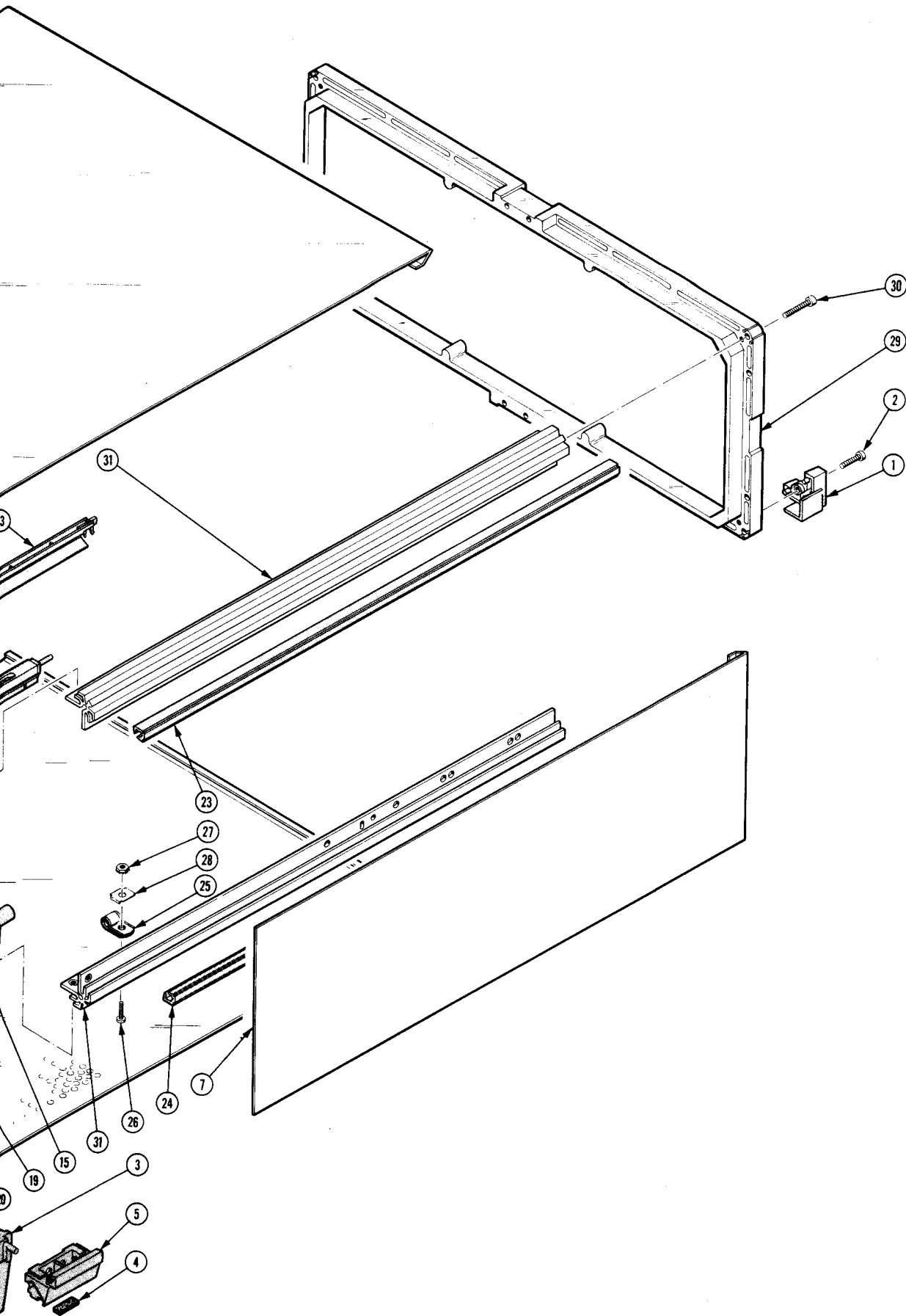

@

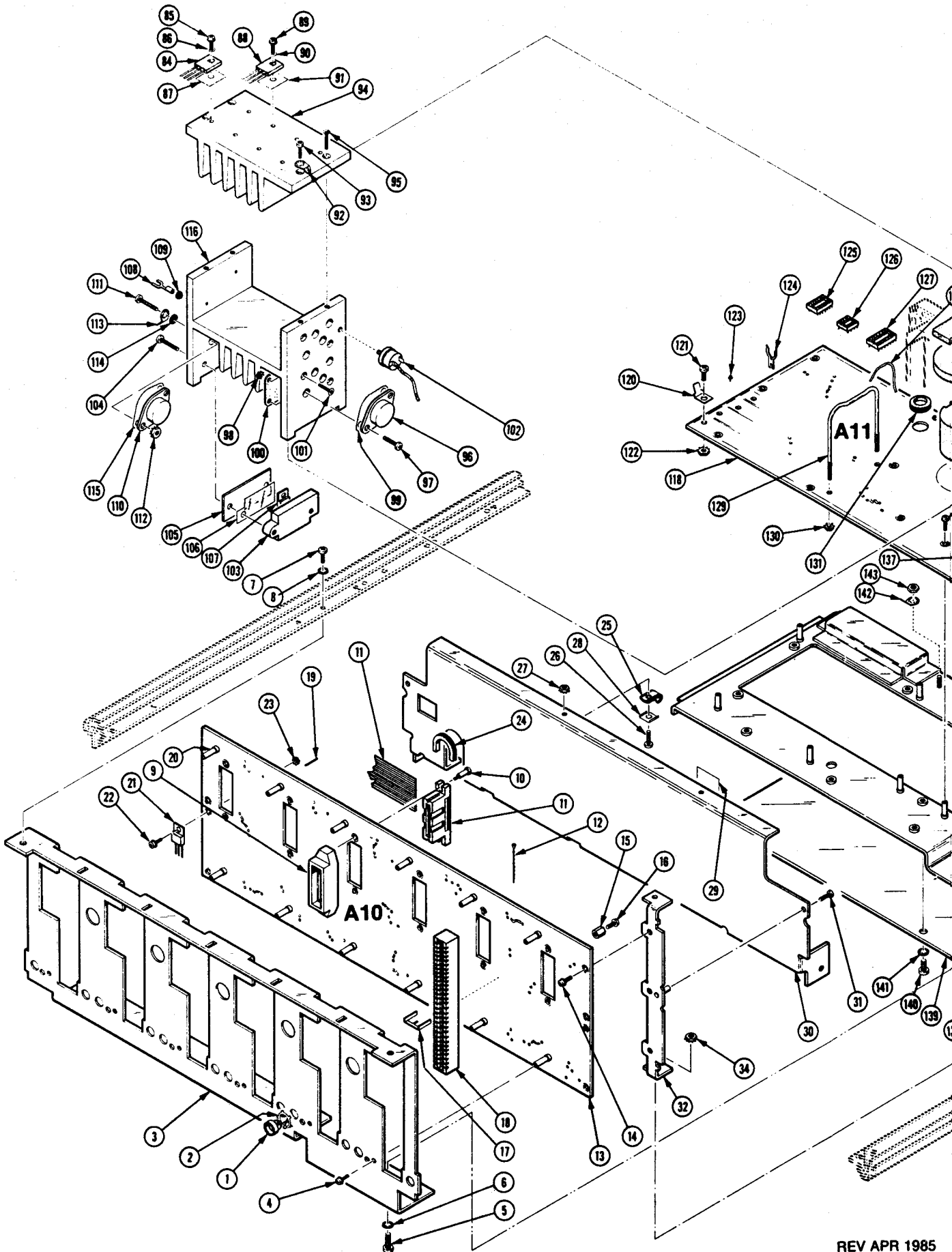

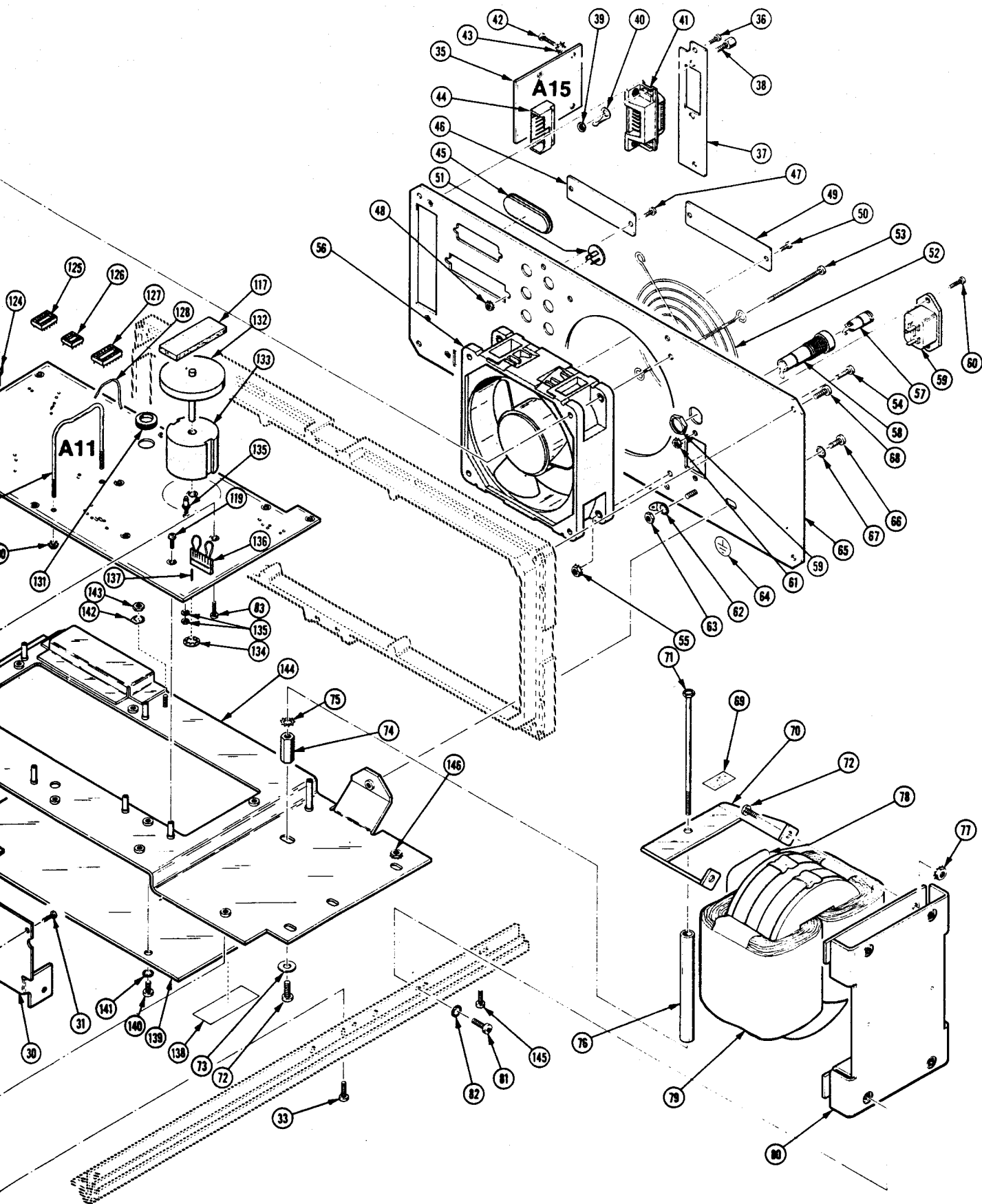

SEE END OF REPLACEABLE MECHANICAL PARTS LIST  
FOR WIRE ASSEMBLIES

REV APR 1985

| Fig. & Index No. | Tektronix Part No. | Serial/Assembly No. Effective Dscnt | Qty | 12345 Name & Description                                                                       | Mfr. Code | Mfr. Part No.    |
|------------------|--------------------|-------------------------------------|-----|------------------------------------------------------------------------------------------------|-----------|------------------|
| 2-1              | 348-0640-00        |                                     | 12  | GROMMET, PLASTIC: BLACK, ROUND, 0.188 ID                                                       | 80009     | 348-0640-00      |
| -2               | 214-3026-00        |                                     | 12  | SPRING, GROUND: CU BE                                                                          | TK1569    | ORDER BY DESCR   |
|                  | 334-2380-00        | B020400                             | 1   | MARKER, IDENT: MKD HIGH POWER COMPARTMENT                                                      | 80009     | 334-2380-00      |
| -3               | 386-4349-00        |                                     | 1   | SUPPORT, CKT BD: INTERFACE, AL<br>(ATTACHING PARTS)                                            | 80009     | 386-4349-00      |
| -4               | 211-0244-00        |                                     | 12  | SCR, ASSEM WSHR: 4-40 X 0.312, PNH STL                                                         | TK0858    | 211-0244-00      |
| -5               | 212-0023-00        |                                     | 4   | SCREW, MACHINE: 8-32 X 0.375, PNH, STL                                                         | TK0435    | ORDER BY DESCR   |
| -6               | 210-0008-00        |                                     | 4   | WASHER, LOCK: #8 INTL, 0.02 THK, STL                                                           | 77900     | 1208-00-00-0541C |
| -7               | 211-0504-00        |                                     | 2   | SCREW, MACHINE: 6-32 X 0.250, PNH, STL                                                         | TK0435    | ORDER BY DESCR   |
| -8               | 210-0006-00        |                                     | 2   | WASHER, LOCK: #6 INTL, 0.018 THK, STL<br>(END ATTACHING PARTS)                                 | 77900     | 1206-00-00-0541C |
| -9               | 380-0655-00        |                                     | 6   | HOUSING, CONN: FLOATING, PLASTIC<br>(ATTACHING PARTS)                                          | 80009     | 380-0655-00      |
| -10              | 211-0295-00        |                                     | 12  | SCREW, SHOULDER: 2-56 X 0.54, HEX HD, STL<br>(END ATTACHING PARTS)                             | 80009     | 211-0295-00      |
| -11              | 175-3248-00        |                                     | 1   | CA ASSY, SP, ELEC: 20, 26 AWG, 20.4 L                                                          | 22526     | 80173-001        |
| -12              | 006-0531-00        |                                     | 6   | STRAP, TIEDOWN, E: BLUE PLASTIC BEADED                                                         | 24618     | 700-3688         |
| -13              | -----              |                                     | 1   | CKT BOARD ASSY: MAIN INTOCON (SEE A10 REPL)<br>(ATTACHING PARTS)                               |           |                  |
| -14              | 211-0244-00        |                                     | 6   | SCR, ASSEM WSHR: 4-40 X 0.312, PNH STL<br>(END ATTACHING PARTS)                                | TK0858    | 211-0244-00      |
| -15              | 361-1084-00        |                                     | 1   | CKT BOARD ASSY INCLUDES:<br>.SPACER, ACTUATOR: 0.33 L X 0.25 DIA, PLASTIC<br>(ATTACHING PARTS) | 80009     | 361-1084-00      |
| -16              | 211-0244-00        |                                     | 1   | .SCR, ASSEM WSHR: 4-40 X 0.312, PNH STL<br>(END ATTACHING PARTS)                               | TK0858    | 211-0244-00      |
| -17              | 214-1593-02        |                                     | 6   | .KEY, CONN PLZN: CKT BOARD CONN                                                                | 80009     | 214-1593-02      |
| -18              | -----              |                                     | 6   | .CONNECTOR, RCPT: (SEE A10J1000, J1100, J1200,<br>J1300, J1400, J1500 REPL)                    |           |                  |
| -19              | -----              |                                     | 6   | .TERMINAL, PIN: (SEE A10J1520, J1530 REPL)                                                     |           |                  |
|                  | 131-0608-00        |                                     | 306 | .TERMINAL, PIN: 0.365 L X 0.025 BRZ GLD PL<br>(OPTION 02, 12 ONLY)                             | 22526     | 48283-036        |
| -20              | 129-0814-00        |                                     | 12  | .SPACER, POST: 0.622L, 4-40 INT, BRS, 0.28800                                                  | 80009     | 129-0814-00      |
| -21              | -----              |                                     | 1   | .TRANSISTOR: (SEE A10Q1525 REPL)<br>(ATTACHING PARTS)                                          |           |                  |
| -22              | 211-0244-00        |                                     | 1   | .SCR, ASSEM WSHR: 4-40 X 0.312, PNH STL                                                        | TK0858    | 211-0244-00      |
| -23              | 210-0586-00        |                                     | 1   | NUT, PL, ASSEM WA: 4-40 X 0.25, STL CD PL<br>(END ATTACHING PARTS)                             | 78189     | 211-041800-00    |
| -24              | 358-0166-00        |                                     | 1   | GROMMET, PLASTIC: BLACK, U-SHAPE, 0.656 ID                                                     | 80009     | 358-0166-00      |
| -25              | 343-0004-00        |                                     | 2   | CLAMP, LOOP: 0.312 ID, PLASTIC<br>(ATTACHING PARTS)                                            | 06915     | E5 CLEAR ROUND   |
| -26              | 211-0578-00        |                                     | 2   | SCREW, MACHINE: 6-32 X 0.438, PNH, STL                                                         | TK0435    | ORDER BY DESCR   |
| -27              | 210-0457-00        |                                     | 2   | NUT, PL, ASSEM WA: 6-32 X 0.312, STL CD PL                                                     | 78189     | 511-061800-00    |
| -28              | 210-0863-00        |                                     | 2   | WSHR, LOOP CLAMP: 0.187 ID U/W 0.5 W CLP<br>(END ATTACHING PARTS)                              | 95987     | C191             |
| -29              | 334-4126-00        |                                     | 2   | MARKER, IDENT: MKD WARNING                                                                     | 80009     | 334-4126-00      |
| -30              | 337-2903-00        |                                     | 1   | SHIELD, ELEC: CIRCUIT BOARD<br>(ATTACHING PARTS)                                               | 80009     | 337-2903-00      |
| -31              | 211-0244-00        |                                     | 4   | SCR, ASSEM WSHR: 4-40 X 0.312, PNH STL<br>(END ATTACHING PARTS)                                | TK0858    | 211-0244-00      |
| -32              | 386-4350-00        |                                     | 2   | SUPPORT, CKT BD: INTERFACE, AL<br>(ATTACHING PARTS)                                            | 80009     | 386-4350-00      |
| -33              | 211-0510-00        |                                     | 4   | SCREW, MACHINE: 6-32 X 0.375, PNH, STL                                                         | 83385     | ORDER BY DESCR   |
| -34              | 210-0457-00        |                                     | 4   | NUT, PL, ASSEM WA: 6-32 X 0.312, STL CD PL<br>(END ATTACHING PARTS)                            | 78189     | 511-061800-00    |
| -35              | -----              |                                     | 1   | CKT BOARD ASSY: GPIB INTERCON (SEE A15 REPL)<br>(ATTACHING PARTS)                              |           |                  |
| -36              | 211-0244-00        |                                     | 2   | SCR, ASSEM WSHR: 4-40 X 0.312, PNH STL<br>(END ATTACHING PARTS)                                | TK0858    | 211-0244-00      |
| -37              | 333-2648-00        |                                     | 1   | CKT BOARD ASSY INCLUDES:<br>.PANEL, FRONT: GPIB<br>(ATTACHING PARTS)                           | 80009     | 333-2648-00      |
| -38              | 214-3312-00        |                                     | 2   | .HARDWARE KIT: JACKSOCKET FOR GPIB                                                             | 00779     | 552633-4         |
| -39              | 220-0555-00        |                                     | 2   | .NUT, PLAIN, HEX: 8-32 X 0.25 HEX, STL CD PL                                                   | TK0433    | ORDER BY DESCR   |
| -40              | 210-0202-00        |                                     | 1   | .TERMINAL, LUG: 0.146 ID, LOCKING, BRZ TIN PL<br>(END ATTACHING PARTS)                         | 86928     | A-373-158-2      |
| -41              | -----              |                                     | 1   | .CONN, RCPT, ELEC: (SEE A15J1110 REPL)<br>(ATTACHING PARTS)                                    |           |                  |

Replaceable Mechanical Parts - TM 5006

| Fig. & Index No. | Tektronix Part No. | Serial/Assembly No. Effective | Dscont  | Qty | 12345 Name & Description                                             | Mfr. Code | Mfr. Part No.    |
|------------------|--------------------|-------------------------------|---------|-----|----------------------------------------------------------------------|-----------|------------------|
| 2-42             | 213-0267-00        |                               |         | 2   | .SCREW,TPG,TC:4-24 X 0.375,PAN HD,STL                                | 83385     | ORDER BY DESCR   |
| -43              | 210-0003-00        |                               |         | 2   | .WASHER,LOCK:#4 EXT,0.015 THK,STL<br>(END ATTACHING PARTS)           | 78189     | 1104-00-00-0541C |
| -44              | -----              |                               |         | 1   | .CONN,RCPT,ELEC:(SEE A15J1010 REPL)                                  |           |                  |
| -45              | 200-0814-00        |                               |         | 1   | CABLE NIP,ELEC:0.195-0.265 ID X 0.255 L,GY                           | 80009     | 200-0814-00      |
| -46              | 200-2467-00        |                               |         | 1   | COVER,CONNECTOR:ALUMINUM<br>(ATTACHING PARTS)                        | 80009     | 200-2467-00      |
| -47              | 211-0244-00        |                               |         | 2   | SCR,ASSEM WSHR:4-40 X 0.312,PNH STL                                  | TK0858    | 211-0244-00      |
| -48              | 210-0586-00        |                               |         | 2   | NUT,PL,ASSEM WA:4-40 X 0.25,STL CD PL<br>(END ATTACHING PARTS)       | 78189     | 211-041800-00    |
| -49              | 200-2465-00        |                               |         | 1   | COVER,CA INSERT:ALUMINUM<br>(ATTACHING PARTS)                        | 80009     | 200-2465-00      |
| -50              | 211-0244-00        |                               |         | 2   | SCR,ASSEM WSHR:4-40 X 0.312,PNH STL<br>(END ATTACHING PARTS)         | TK0858    | 211-0244-00      |
| -51              | 134-0159-00        |                               |         | 6   | BUTTON,PLUG:0.38 DIA,PLASTIC                                         | 80009     | 134-0159-00      |
| -52              | 200-2222-00        |                               |         | 1   | GUARD,FAN:<br>(ATTACHING PARTS)                                      | 81041     | 6-182-033        |
| -53              | 211-0552-00        |                               |         | 2   | SCREW,MACHINE:6-32 X 2.0,PNH,STL                                     | TK0435    | ORDER BY DESCR   |
| -54              | 211-0513-00        |                               |         | 2   | SCREW,MACHINE:6-32 X 0.625,PNH,STL                                   | 93907     | 880-00032-003    |
| -55              | 210-0457-00        |                               |         | 2   | NUT,PL,ASSEM WA:6-32 X 0.312,STL CD PL                               | 78189     | 511-061800-00    |
|                  | 361-1194-00        |                               |         | 2   | SPACER,SLEEVE:0.965 L X 0.035 ID,AL<br>(END ATTACHING PARTS)         | 80009     | 361-1194-00      |
| -56              | -----              |                               |         | 1   | FAN,VENTILATING:(SEE B500 REPL)                                      |           |                  |
| -57              | 200-2264-00        |                               |         | 1   | CAP,FUSEHOLDER:3AG FUSES                                             | S3629     | FEK 031 1666     |
| -58              | 204-0832-00        |                               |         | 1   | BODY,FUSEHOLDER:3AG & 5 X 20MM FUSES                                 | TK0861    | 031 1673         |
| -59              | -----              |                               |         | 1   | FILTER,RFI:(SEE FL500 REPL)<br>(ATTACHING PARTS)                     |           |                  |
| -60              | 211-0012-00        |                               |         | 2   | SCREW,MACHINE:4-40 X 0.375,PNH,STL                                   | TK0435    | ORDER BY DESCR   |
| -61              | 210-0586-00        |                               |         | 2   | NUT,PL,ASSEM WA:4-40 X 0.25,STL CD PL<br>(END ATTACHING PARTS)       | 78189     | 211-041800-00    |
| -62              | 210-0205-00        |                               |         | 2   | TERMINAL,LUG:0.172 ID,LOCKING,BRS TIN PL<br>(ATTACHING PARTS)        | 86928     | 5442-7           |
| -63              | 210-0409-00        |                               |         | 2   | NUT,PLAIN,HEX:8-32 X 0.312,BRS CD PL<br>(END ATTACHING PARTS)        | 73743     | 3046-402         |
| -64              | 334-3379-03        | B010100                       | B010134 | 2   | MARKER,IDENT:MARKED GROUND SYMBOL                                    | 80009     | 334-3379-03      |
|                  | 334-3379-03        | B010135                       |         | 1   | MARKER,IDENT:MARKED GROUND SYMBOL                                    | 80009     | 334-3379-03      |
| -65              | 333-2633-00        | B010100                       | B037063 | 1   | PANEL,REAR:                                                          | 80009     | 333-2633-00      |
|                  | 333-2633-01        | B037064                       |         | 1   | PANEL,REAR:<br>(ATTACHING PARTS)                                     | 80009     | 333-2633-01      |
| -66              | 212-0023-00        |                               |         | 1   | SCREW,MACHINE:8-32 X 0.375,PNH,STL                                   | TK0435    | ORDER BY DESCR   |
| -67              | 210-0008-00        |                               |         | 1   | WASHER,LOCK:#8 INTL,0.02 THK,STL                                     | 77900     | 1208-00-00-0541C |
| -68              | 213-0801-00        |                               |         | 8   | SCREW,TPG,TF:8-32 X 0.312,TAPTITE,PNH,STL<br>(END ATTACHING PARTS)   | 83486     | ORDER BY DESCR   |
| -69              | 334-2332-00        |                               |         | 1   | MARKER,IDENT:DANGER:VOLTAGE IN THIS AREA                             | 80009     | 334-2332-00      |
| -70              | 407-2497-00        |                               |         | 2   | BRACKET,XFMR:ALUMINUM<br>(ATTACHING PARTS)                           | 80009     | 407-2497-00      |
| -71              | 212-0565-00        |                               |         | 1   | SCREW,MACHINE:10-32 X 4.25,HEX HD,STL                                | 83385     | ORDER BY DESCR   |
| -72              | 212-0507-00        |                               |         | 5   | SCREW,MACHINE:10-32 X 0.375,PNH,STL                                  | TK0435    | ORDER BY DESCR   |
| -73              | 210-1227-00        |                               |         | 1   | WASHER,FLAT:0.203 ID X 0.5 OD X 0.048,STL                            | 12327     | ORDER BY DESCR   |
|                  | 211-0009-00        |                               |         | 1   | SCREW,MACHINE:4-40 X 0.25,OVH,STL                                    | 83385     | ORDER BY DESCR   |
| -74              | 129-0606-00        |                               |         | 1   | SPACER,POST:0.9 L,10-32 THRU,AL,0.375 HEX                            | 80009     | 129-0606-00      |
| -75              | 210-0009-00        |                               |         | 1   | WASHER,LOCK:#10 EXT,0.022 THK,STL                                    | 78189     | 1110-00          |
| -76              | 361-1040-00        |                               |         | 1   | SPACER,SLEEVE:3.66 L X 0.245 ID,AL                                   | 80009     | 361-1040-00      |
| -77              | 220-0410-00        |                               |         | 4   | NUT,PL,ASSEM WA:10-32 X 0.375 HEX,STL CD PL<br>(END ATTACHING PARTS) | 78189     | 511-101800-50    |
| -78              | 342-0028-00        |                               |         | 2   | INSULATOR,PLATE:TRANSFORMER,ANODIZED AL                              | 80009     | 342-0028-00      |
| -79              | -----              |                               |         | 1   | XFMR,PWR,STPDN:(SEE T500 REPL)                                       |           |                  |
| -80              | 386-4351-00        |                               |         | 1   | SUPPORT,XFMR:ALUMINUM<br>(ATTACHING PARTS)                           | 80009     | 386-4351-00      |
| -81              | 212-0023-00        |                               |         | 4   | SCREW,MACHINE:8-32 X 0.375,PNH,STL                                   | TK0435    | ORDER BY DESCR   |
| -82              | 210-0008-00        |                               |         | 4   | WASHER,LOCK:#8 INTL,0.02 THK,STL<br>(END ATTACHING PARTS)            | 77900     | 1208-00-00-0541C |
|                  | 650-0571-00        |                               |         | 1   | HEAT SINK ASSY:POWER SUPPLY<br>(ATTACHING PARTS)                     | 80009     | 650-0571-00      |
| -83              | 211-0244-00        |                               |         | 4   | SCR,ASSEM WSHR:4-40 X 0.312,PNH STL<br>(END ATTACHING PARTS)         | TK0858    | 211-0244-00      |
| -84              | -----              |                               |         | 5   | .TRANSISTOR:(SEE Q510,Q530,Q550,Q570,<br>.Q590 REPL)                 |           |                  |



| Fig. & Index No. | Tektronix Part No. | Serial/Assembly No. Effective | Discort | Qty | 12345 Name & Description                                                              | Mfr. Code | Mfr. Part No. |
|------------------|--------------------|-------------------------------|---------|-----|---------------------------------------------------------------------------------------|-----------|---------------|
| 2-               |                    |                               |         |     | .(ATTACHING PARTS)                                                                    |           |               |
| -85              | 211-0012-00        |                               |         | 5   | .SCREW,MACHINE:4-40 X 0.375,PNH,STL                                                   | TK0435    | ORDER BY DESC |
| -86              | 210-1122-00        |                               |         | 5   | .WASHER,LOCK:0.12 ID,DISHED,0.025 THK,STL                                             | 86928     | ORDER BY DESC |
| -87              | 342-0163-00        |                               |         | 5   | .INSULATOR,PLATE:TRANSISTOR,MICA                                                      | 80009     | 342-0163-00   |
|                  |                    |                               |         |     | .(END ATTACHING PARTS)                                                                |           |               |
| -88              | -----              |                               |         | 5   | .TRANSISTOR:(SEE Q500,Q520,Q540,Q560,<br>.Q580 REPL)                                  |           |               |
|                  |                    |                               |         |     | .(ATTACHING PARTS)                                                                    |           |               |
| -89              | 211-0012-00        |                               |         | 5   | .SCREW,MACHINE:4-40 X 0.375,PNH,STL                                                   | TK0435    | ORDER BY DESC |
| -90              | 210-1122-00        |                               |         | 5   | .WASHER,LOCK:0.12 ID,DISHED,0.025 THK,STL                                             | 86928     | ORDER BY DESC |
| -91              | 342-0163-00        |                               |         | 5   | .INSULATOR,PLATE:TRANSISTOR,MICA                                                      | 80009     | 342-0163-00   |
|                  |                    |                               |         |     | .(END ATTACHING PARTS)                                                                |           |               |
| -92              | 210-0202-00        |                               |         | 1   | .TERMINAL,LUG:0.146 ID,LOCKING,BRZ TIN PL                                             | 86928     | A-373-158-2   |
|                  |                    |                               |         |     | .(ATTACHING PARTS)                                                                    |           |               |
| -93              | 211-0014-00        |                               |         | 1   | .SCREW,MACHINE:4-40 X 0.5,PNH,STL                                                     | TK0435    | ORDER BY DESC |
|                  |                    |                               |         |     | .(END ATTACHING PARTS)                                                                |           |               |
| -94              | 214-3126-00        |                               |         | 1   | .HEAT SINK,XSTR:(8)TO-127, TOP,AL                                                     | 80009     | 214-3126-00   |
|                  |                    |                               |         |     | .(ATTACHING PARTS)                                                                    |           |               |
| -95              | 211-0102-00        |                               |         | 3   | .SCREW,MACHINE:4-40 X 0.5,FLH,100 DEG,STL                                             | TK0435    | ORDER BY DESC |
|                  |                    |                               |         |     | .(END ATTACHING PARTS)                                                                |           |               |
| -96              | -----              |                               |         | 2   | .TRANSISTOR:(SEE Q600,Q610 REPL)                                                      |           |               |
|                  |                    |                               |         |     | .(ATTACHING PARTS)                                                                    |           |               |
| -97              | 213-0185-00        |                               |         | 4   | .SCREW,TPG,TF:6-20 X 0.625,TYPE B,PNH,STL                                             | TK0435    | 3012          |
| -98              | 210-0586-00        |                               |         | 4   | .NUT,PL,ASSEM WA:4-40 X 0.25,STL CD PL                                                | 78189     | 211-041800-00 |
| -99              | 386-0978-00        |                               |         | 2   | .INSULATOR,PLATE:TRANSISTOR,MICA                                                      | 16037     | #130          |
| -100             | 136-0280-00        |                               |         | 2   | .SKT,PL-IN ELEK:TRANSISTOR,3 CONTACT                                                  | TK0194    | 1003-1R       |
|                  |                    |                               |         |     | .(END ATTACHING PARTS)                                                                |           |               |
| -101             | 211-0102-00        |                               |         | 4   | .SCREW,MACHINE:4-40 X 0.5,FLH,100 DEG,STL                                             | TK0435    | ORDER BY DESC |
| -102             | -----              |                               |         | 1   | .SW,THERMOSTATIC:(SEE S550 REPL)                                                      |           |               |
| -103             | 200-2269-00        |                               |         | 1   | .COVER,XSTR:                                                                          | 80009     | 200-2269-00   |
|                  |                    |                               |         |     | .(ATTACHING PARTS)                                                                    |           |               |
| -104             | 211-0513-00        |                               |         | 2   | .SCREW,MACHINE:6-32 X 0.625,PNH,STL                                                   | 93907     | B80-00032-003 |
|                  |                    |                               |         |     | .(END ATTACHING PARTS)                                                                |           |               |
| -105             | 342-0449-01        |                               |         | 1   | .INSULATOR,PLATE:TRANSISTOR,ALUMINA                                                   | 80009     | 342-0449-01   |
| -106             | 342-0458-00        |                               |         | 1   | .INSULATOR,PLATE:TRANSISTOR,MICA                                                      | 86928     | ORDER BY DESC |
| -107             | -----              |                               |         | 2   | .TRANSISTOR:(SEE Q1640,Q1650 REPL)                                                    |           |               |
| -108             | 210-0230-00        |                               |         | 2   | .TERMINAL,LUG:#6 STUD,SOLDERLESS                                                      | 98410     | A-134-06      |
| -109             | 129-0222-00        |                               |         | 2   | .SPACER,POST:0.27 L,4-40 THRU,PLSTC,0.25 OD                                           | 80009     | 129-0222-00   |
| -110             | -----              |                               |         | 1   | .SEMICONV DEVICE:(SEE CR500 REPL)                                                     |           |               |
|                  |                    |                               |         |     | .(ATTACHING PARTS)                                                                    |           |               |
| -111             | 211-0513-00        |                               |         | 2   | .SCREW,MACHINE:6-32 X 0.625,PNH,STL                                                   | 93907     | B80-00032-003 |
| -112             | 210-0457-00        |                               |         | 2   | .NUT,PL,ASSEM WA:6-32 X 0.312,STL CD PL                                               | 78189     | 511-061800-00 |
| -113             | 210-0202-00        |                               |         | 1   | .TERMINAL,LUG:0.146 ID,LOCKING,BRZ TIN PL                                             | 86928     | A-373-158-2   |
| -114             | 210-0967-00        |                               |         | 2   | .WASHER,SHLDR:0.156 ID X 0.375 OD X 0.094 TH<br>.K,NYL                                | 02735     | 495334-7      |
|                  |                    |                               |         |     | .(END ATTACHING PARTS)                                                                |           |               |
| -115             | 386-0978-00        | B010100                       | B020399 | 1   | .INSULATOR,PLATE:TRANSISTOR,MICA                                                      | 16037     | #130          |
|                  | 386-0786-00        | B020400                       |         | 1   | .INSULATOR,PLATE:TRANSISTOR,MICA                                                      | 28205     | ORDER BY DESC |
| -116             | 214-3052-00        |                               |         | 1   | .HEAT SINK,XSTR:BOTTOM,3,TO-3 & 8,TO-126,AL                                           | 80009     | 214-3052-00   |
| -117             | 348-0070-01        |                               |         | 1   | PAD,CUSHIONING:2.03 X 0.69 X 0.18 SI RBR                                              | 85471     | ORDER BY DESC |
| -118             | -----              |                               |         | 1   | CKT BOARD ASSY:POWER SUPPLY(SEE A11 REPL)                                             |           |               |
|                  |                    |                               |         |     | .(ATTACHING PARTS)                                                                    |           |               |
| -119             | 211-0244-00        |                               |         | 7   | SCR,ASSEM WSHR:4-40 X 0.312,PNH STL                                                   | TK0858    | 211-0244-00   |
|                  |                    |                               |         |     | .(END ATTACHING PARTS)                                                                |           |               |
| -120             | -----              |                               |         | 4   | CKT BOARD ASSY INCLUDES:<br>.TERM,QIK DISC:(SEE A11J2220,J2221,J2320,<br>.J2321 REPL) |           |               |
|                  |                    |                               |         |     | .(ATTACHING PARTS)                                                                    |           |               |
| -121             | 211-0504-00        |                               |         | 4   | .SCREW,MACHINE:6-32 X 0.250,PNH,STL                                                   | TK0435    | ORDER BY DESC |
| -122             | 210-0457-00        |                               |         | 4   | .NUT,PL,ASSEM WA:6-32 X 0.312,STL CD PL                                               | 78189     | 511-061800-00 |
|                  |                    |                               |         |     | .(END ATTACHING PARTS)                                                                |           |               |
| -123             | 136-0252-07        |                               |         | 9   | .SOCKET,PIN CONN:W/O DIMPLE                                                           | 22526     | 75060-012     |
| -124             | 344-0154-03        |                               |         | 2   | .CLIP,ELECTRICAL:FUSE,CKT BD MT,CU BE CU-SN-<br>.ZN PL                                | TK1569    | ORDER BY DESC |
| -125             | 136-0269-02        | B010100                       | B021839 | 5   | .SKT,PL-IN ELEK:MICROCIRCUIT,14 DIP                                                   | 09922     | DILB14P-108T  |
| -126             | 136-0514-00        | B010100                       | B021839 | 1   | .SKT,PL-IN ELEK:MICROCIRCUIT,8 DIP                                                    | 09922     | DILB8P-108    |
|                  | 136-0728-00        | B021840                       | B033969 | 1   | .SKT,PL-IN ELEK:MICROCKT,14 CONTACT                                                   | 09922     | DILB14P-108   |
| -127             | 136-0260-02        | B010100                       | B021839 | 1   | .SKT,PL-IN ELEK:MICROCKT,16 DIP,LOW CL                                                | 09922     | DILB16P-108T  |

Replaceable Mechanical Parts - TM 5006

| Fig. & Index No. | Tektronix Part No. | Serial/Assembly No. Effective | Discount | Qty | 12345 Name & Description                                                                                                                                                                                                                                             | Mfr. Code | Mfr. Part No.    |
|------------------|--------------------|-------------------------------|----------|-----|----------------------------------------------------------------------------------------------------------------------------------------------------------------------------------------------------------------------------------------------------------------------|-----------|------------------|
| 2-128            | 346-0032-00        |                               |          | 1   | .STRAP,RETAINING:0.075 DIA X 4.0 L,MLD RBR                                                                                                                                                                                                                           | 98159     | 2829-75-4        |
| -129             | 214-3131-00        |                               |          | 1   | .BOLT,U:6-32 X 2.250 X 1.925,BRASS<br>(ATTACHING PARTS)                                                                                                                                                                                                              | 02114     | 52 U BOLT        |
| -130             | 210-0457-00        |                               |          | 2   | .NUT,PL,ASSEM WA:6-32 X 0.312,STL CD PL<br>(END ATTACHING PARTS)                                                                                                                                                                                                     | 78189     | 511-061800-00    |
| -131             | 348-0005-00        |                               |          | 1   | .GROMMET,RUBBER:BLACK,ROUND,0.375 ID                                                                                                                                                                                                                                 | 70485     | 230X-36017       |
| -132             | 352-0526-00        |                               |          | 1   | .HOLDER,COIL:BLACK NYLON                                                                                                                                                                                                                                             | 80009     | 352-0526-00      |
| -133             | -----              |                               |          | 1   | .COIL,RF:(SEE A11L1440 REPL)<br>(ATTACHING PARTS)                                                                                                                                                                                                                    |           |                  |
| -134             | 354-0553-00        |                               |          | 1   | .RING,RETAINING:EXT CIRC PUSH-ON                                                                                                                                                                                                                                     | 79136     | 5115-18          |
| -135             | 131-0373-00        |                               |          | 1   | .TERMINAL,STUD:0.593 L                                                                                                                                                                                                                                               | 88245     | MTS-7            |
| -136             | 131-1896-00        |                               |          | 2   | .BUS,CONDUCTOR:8.22 AWG,1.5 L                                                                                                                                                                                                                                        | 80009     | 131-1896-00      |
| -137             | -----              |                               |          | 25  | .TERMINAL,PIN:(SEE A11J1000,J1010,J1011,J1<br>.J1013,J1020,J2330 REPL)                                                                                                                                                                                               |           |                  |
| -138             | 334-3621-00        | 8010100                       |          | 1   | MARKER,IDENT:MARKED DANGER,LINE V PRESENT                                                                                                                                                                                                                            | 80009     | 334-3621-00      |
| -139             | 386-4563-00        |                               |          | 1   | PLATE,COVER:POWER SUPPL CHASSIS,AL<br>(ATTACHING PARTS)                                                                                                                                                                                                              | 80009     | 386-4563-00      |
| -140             | 212-0023-00        |                               |          | 5   | SCREW,MACHINE:8-32 X 0.375,PNH,STL                                                                                                                                                                                                                                   | TK0435    | ORDER BY DESCR   |
| -141             | 210-0008-00        |                               |          | 5   | WASHER,LOCK:#8 INTL,0.02 THK,STL<br>(END ATTACHING PARTS)                                                                                                                                                                                                            | 77900     | 1208-00-00-0541C |
| -142             | 210-0205-00        |                               |          | 1   | TERMINAL,LUG:0.172 ID,LOCKING,BRS TIN PL<br>(ATTACHING PARTS)                                                                                                                                                                                                        | 86928     | 5442-7           |
| -143             | 210-0409-00        |                               |          | 1   | NUT,PLAIN,HEX:8-32 X 0.312,BRS CD PL<br>(END ATTACHING PARTS)                                                                                                                                                                                                        | 73743     | 3046-402         |
| -144             | 441-1522-00        |                               |          | 1   | CHAS,PWR SUPPLY:<br>(ATTACHING PARTS)                                                                                                                                                                                                                                | 80009     | 441-1522-00      |
| -145             | 212-0023-00        |                               |          | 6   | SCREW,MACHINE:8-32 X 0.375,PNH,STL                                                                                                                                                                                                                                   | TK0435    | ORDER BY DESCR   |
| -146             | 210-0458-00        |                               |          | 3   | NUT,PL,ASSEM WA:8-32 X 0.344,STL CD PL<br>(END ATTACHING PARTS)                                                                                                                                                                                                      | 78189     | 511-081800-00    |
|                  | 175-2977-00        |                               |          | 5   | WIRE ASSEMBLIES<br>CA ASSY,SP,ELEC:6,22 AWG,10.0 L<br>(FROM A10 TO Q500,Q510) SUBPART OF A10<br>(FROM A10 TO Q520,Q530) SUBPART OF A10<br>(FROM A10 TO Q540,Q560) SUBPART OF A10<br>(FROM A10 TO Q550,Q570) SUBPART OF A10<br>(FROM A10 TO Q580,Q590) SUBPART OF A10 | 80009     | 175-2977-00      |
|                  | 204-0671-00        |                               |          | 10  | .CONN BODY,PLUG:1 X 3 CONTACTS                                                                                                                                                                                                                                       | 27264     | 09-50-7031       |
|                  | 175-3611-00        |                               |          | 1   | CA ASSY,SP,ELEC:3,22 AWG,7.0 L,RIBBON<br>(FROM A10J1530 TO A11J2330 AND A10J2220,<br>.A10J2221,A10J2320,A10J2321 TO A11)<br>.SUBPART OF A10                                                                                                                          | 80009     | 175-3611-00      |
|                  | 352-0161-00        |                               |          | 2   | .HLDR,TERM CONN:3 WIRE,BLACK                                                                                                                                                                                                                                         | 80009     | 352-0161-00      |
|                  | 195-0648-00        |                               |          | 1   | LEAD,ELECTRICAL:12,AWG,11.0 L,2-N<br>(FROM A10 TO A11+8) SUBPART OF A10                                                                                                                                                                                              | 80009     | 195-0648-00      |
|                  | 195-0649-00        |                               |          | 1   | LEAD,ELECTRICAL:12 AWG,11.0 L,0-N<br>(FROM A10 TO A11 GRD) SUBPART OF A10                                                                                                                                                                                            | 80009     | 195-0649-00      |
|                  | 195-0650-00        |                               |          | 1   | LEAD,ELECTRICAL:18 AWG,12.0 L,2-1<br>(FROM A10 TO A11+26) SUBPART OF A10                                                                                                                                                                                             | 80009     | 195-0650-00      |
|                  | 195-0651-00        |                               |          | 1   | LEAD,ELECTRICAL:18 AWG,12.0 L,7-1<br>(FROM A10 TO A11-26) SUBPART OF A10                                                                                                                                                                                             | 80009     | 195-0651-00      |
|                  | 195-0948-00        |                               |          | 1   | LEAD,ELECTRICAL:22 AWG,5.5 L,8-0<br>(FROM A11 TO A11) SUBPART OF A11                                                                                                                                                                                                 | 80009     | 195-0948-00      |
|                  | 175-3610-00        |                               |          | 1   | CA ASSY,SP,ELEC:6,22 AWG,10.0 L,RIBBON<br>(FROM A11 TO Q610,Q600)                                                                                                                                                                                                    | 80009     | 175-3610-00      |
|                  | 195-1948-00        |                               |          | 1   | LEAD,ELECTRICAL:18 AWG,4.0 L,8-03<br>(FROM A11 TO S550)                                                                                                                                                                                                              | 80009     | 195-1948-00      |
|                  | 195-0947-00        |                               |          | 2   | LEAD,ELECTRICAL:22 AWG,1.5 L,8-0<br>(FROM A11 TO HEAT SINK) SUBPART OF A11                                                                                                                                                                                           | 80009     | 195-0947-00      |
|                  | 175-3352-00        |                               |          | 1   | CA ASSY,SP,ELEC:4,18 AWG,24.0 L<br>(FROM A11J500,S550 TO S500)                                                                                                                                                                                                       | 80009     | 175-3352-00      |
|                  | 198-4448-00        |                               |          | 1   | WIRE SET,ELEC:<br>(FROM A11J1010 TO B500)                                                                                                                                                                                                                            | 80009     | 198-4448-00      |
|                  | 352-0161-00        |                               |          | 1   | .HLDR,TERM CONN:3 WIRE,BLACK                                                                                                                                                                                                                                         | 80009     | 352-0161-00      |
|                  | 195-1123-00        |                               |          | 1   | LEAD,ELECTRICAL:18 AWG,2.0 L,8-0<br>(FROM J500 TO F500)                                                                                                                                                                                                              | 80009     | 195-1123-00      |
|                  | 195-0652-00        |                               |          | 1   | LEAD,ELECTRICAL:18 AWG,4.0 L,5-4<br>(FROM J500 TO REAR PANEL)                                                                                                                                                                                                        | 80009     | 195-0652-00      |

| Fig. &<br>Index<br>No. | Tektronix<br>Part No. | Serial/Assembly No. |         | Qty | 12345 Name & Description                                                                                                                                   | Mfr.   |                |
|------------------------|-----------------------|---------------------|---------|-----|------------------------------------------------------------------------------------------------------------------------------------------------------------|--------|----------------|
|                        |                       | Effective           | Discont |     |                                                                                                                                                            | Code   | Mfr. Part No.  |
| 3-1                    | 351-0636-00           |                     |         | AR  | SLIDE,DWR,EXT:20.0 X 1.69,PAIR,R&L                                                                                                                         | 80009  | 351-0636-00    |
| -2                     | 351-0104-03           |                     |         | AR  | SL SECT,DWR EXT:12.625 L,W/O HARDWARE<br>(ATTACHING PARTS)                                                                                                 | 06666  | C-720-3        |
| -3                     | 212-0070-00           |                     |         | 10  | SCREW,MACHINE:8-32 X 0.312,FLH,100 DEG,STL                                                                                                                 | TK0435 | ORDER BY DESCR |
| -4                     | 210-0458-00           |                     |         | 10  | NUT,PL,ASSEM WA:8-32 X 0.344,STL CD PL<br>(END ATTACHING PARTS)                                                                                            | 78189  | 511-081800-00  |
| -5                     | 105-0787-00           |                     |         | 2   | LATCH,RETAINING:RACKMOUNT,SST                                                                                                                              | 80009  | 105-0787-00    |
| -6                     | 105-0786-03           |                     |         | 2   | RELEASE,LATCH:PLASTIC,SMOKE TAN                                                                                                                            | 80009  | 105-0786-03    |
| -7                     | 390-0809-06           | B010100             | B022169 | 1   | CABINET SIDE:RIGHT,W/HANDLE<br>(OPTION 10,12 ONLY)                                                                                                         | 80009  | 390-0809-06    |
|                        | 390-0887-02           | B022170             |         | 1   | CABINET SIDE:RIGHT,W/HANDLE<br>(OPTION 10,12 ONLY)                                                                                                         | 80009  | 390-0887-02    |
|                        | 390-0809-05           | B010100             | B022169 | 1   | CABINET SIDE:LEFT W/HANDLE<br>(OPTION 10,12 ONLY)                                                                                                          | 80009  | 390-0809-05    |
|                        | 390-0887-01           | B022170             |         | 1   | CABINET SIDE:LEFT,W/HANDLE<br>(OPTION 10,12 ONLY)<br>(ATTACHING PARTS)                                                                                     | 80009  | 390-0887-01    |
| -8                     | 212-0567-00           |                     |         | 2   | SCREW,MACHINE:10-32 X 0.875,OVH,STL                                                                                                                        | TK0435 | ORDER BY DESCR |
| -9                     | 210-1298-00           |                     |         | 2   | WSHR,SHLDR&RECD:0.195 ID X 0.57 OD,PLSTC                                                                                                                   | 80009  | 210-1298-00    |
| -10                    | 213-0183-00           |                     |         | 4   | SCREW,TPG,TF:6-20 X 0.5,TYPE B,PNH,STL<br>(END ATTACHING PARTS)                                                                                            | 83385  | ORDER BY DESCR |
| -11                    | 124-0389-01           |                     |         | 2   | STRIP,TRIM:RACK MT HDL,VINYL TAPE<br>(WHEN SECURING THE INSTRUMENT TO THE RACK<br>.WITH SCREWS USE A SHARP KNIFE TO CUT SCREW<br>.HOLE IN THE TRIM STRIP.) | 80009  | 124-0389-01    |
| -12                    | 124-0354-03           |                     |         | 2   | STRIP,TRIM:CORNER, TOP, EARTH BROWN 17.41 L                                                                                                                | 80009  | 124-0354-03    |
| -13                    | 131-0955-00           |                     |         | 6   | CONN,RCPT,ELEC:BNC,FEMALE<br>(OPTION 02,12 ONLY)                                                                                                           | 13511  | 31-279         |
| -14                    | 210-0255-00           |                     |         | 6   | TERMINAL,LUG:0.391 ID,LOCKING,BRS CD PL<br>(OPTION 02,12 ONLY)                                                                                             | 12327  | ORDER BY DESCR |
| -15                    | 131-1344-00           |                     |         | 1   | CONN,PLUG,ELEC:D SERIES,50 CONT,MALE<br>(OPTION 02,12 ONLY)                                                                                                | 71468  | DD-50P         |
| -16                    | 211-0008-00           |                     |         | 2   | SCREW,MACHINE:4-40 X 0.25,PNH,STL<br>(OPTION 02,12 ONLY)                                                                                                   | 93907  | ORDER BY DESCR |
| -17                    | 210-0586-00           |                     |         | 2   | NUT,PL,ASSEM WA:4-40 X 0.25,STL CD PL<br>(OPTION 02,12 ONLY)                                                                                               | 78189  | 211-041800-00  |
|                        | 334-1377-00           |                     |         | 1   | MARKER,IDENT:MKD IDENTIFICATION NO.<br>(OPTION 02,12 ONLY)                                                                                                 | 80009  | 334-1377-00    |

### OPTION 10

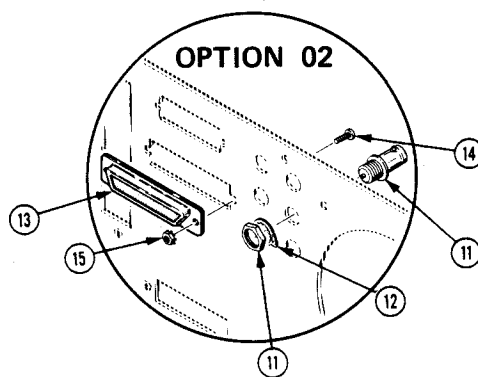
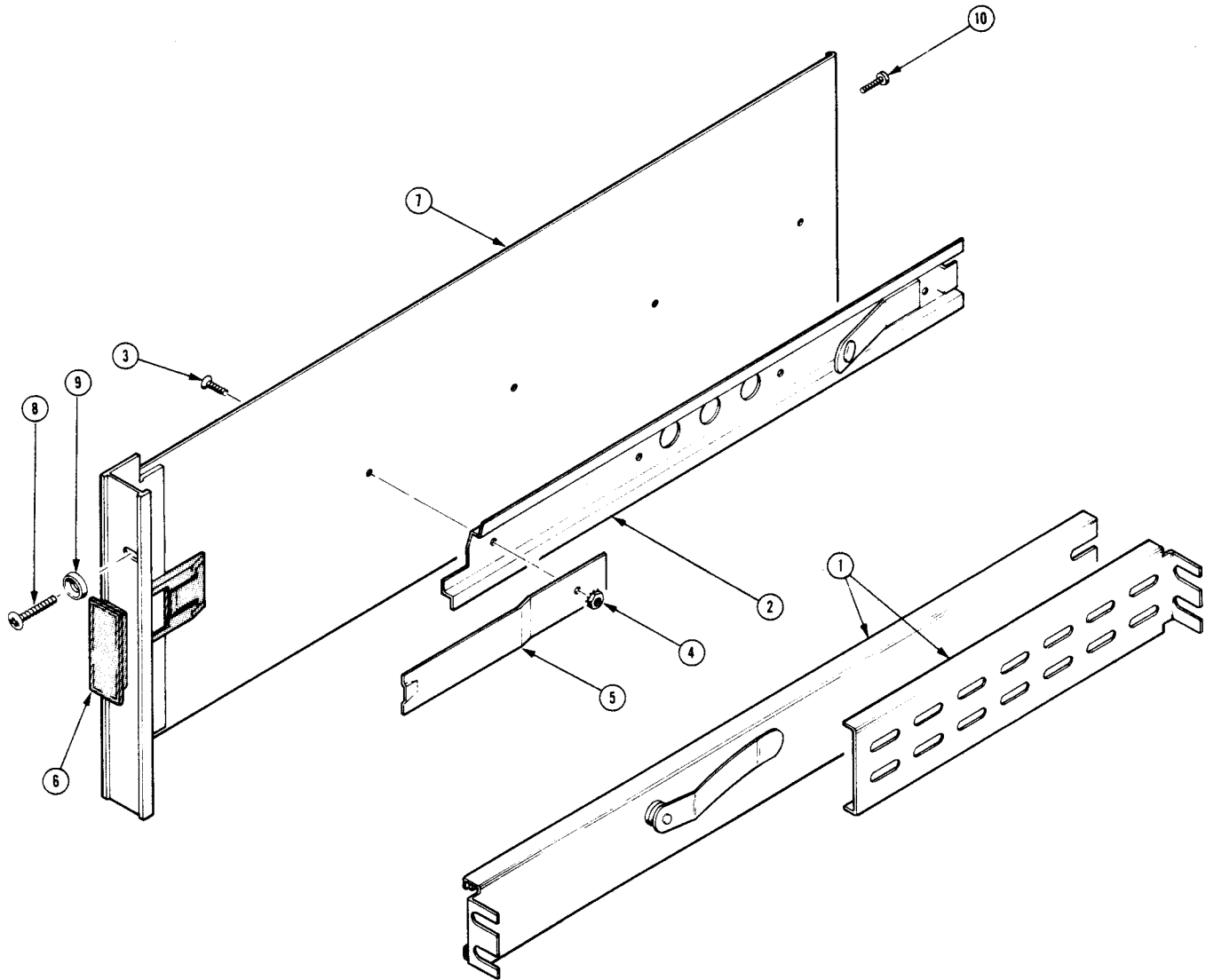

REV NOV 1984

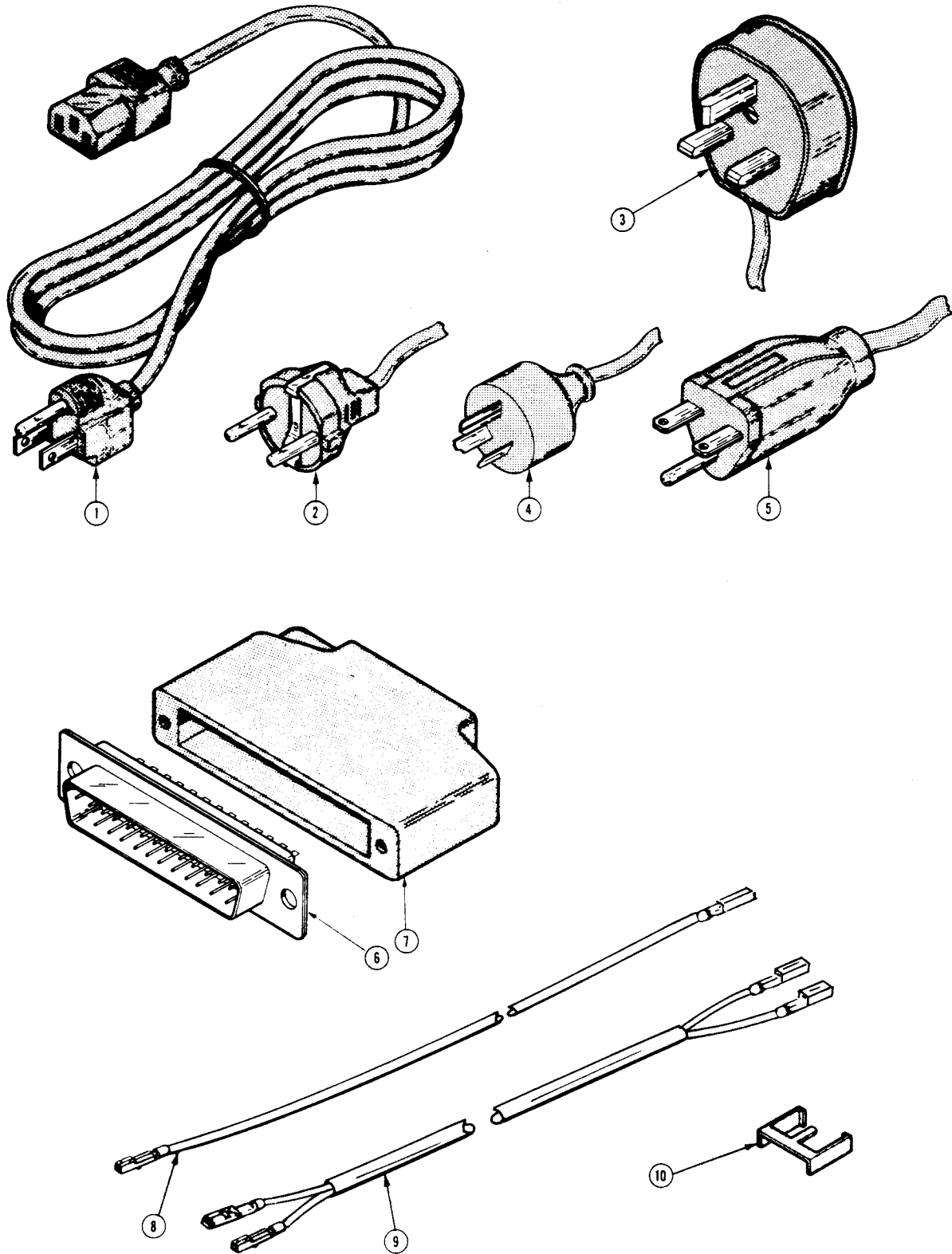

REV APR 1985

| Fig. &<br>Index<br>No. | Tektronix<br>Part No. | Serial/Assembly No. |         | Qty | 12345<br>Name & Description                                                | Mfr.   |                |
|------------------------|-----------------------|---------------------|---------|-----|----------------------------------------------------------------------------|--------|----------------|
|                        |                       | Effective           | Discont |     |                                                                            | Code   | Mfr. Part No.  |
| 4-1                    | -----                 |                     |         | AR  | STANDARD ACCESSORIES                                                       |        |                |
|                        | 070-2950-00           |                     |         | 1   | MANUAL, TECH: INSTR, TM5006                                                | 80009  | 070-2950-00    |
|                        | 161-0066-00           |                     |         | 1   | CABLE ASSY, PWR, :3, 18AWG, 115V, 98.0 L<br>(STANDARD ONLY)                | 16428  | CH8481, FH8481 |
| -2                     | 161-0066-09           |                     |         | 1   | CABLE ASSY, PWR, :3, 0.75MM SQ, 220V, 99.0 L<br>(OPTION A1 EUROPEAN)       | S3109  | 86511000       |
| -3                     | 161-0066-10           |                     |         | 1   | CABLE ASSY, PWR, :3, 0.75MM SQ, 240V, 96.0 L<br>(OPTION A2 UNITED KINGDOM) | TK1373 | 24230          |
| -4                     | 161-0066-11           |                     |         | 1   | CABLE ASSY, PWR, :3, 0.75MM, 240V, 96.0 L<br>(OPTION A3 AUSTRALIAN)        | S3109  | ORDER BY DESC  |
| -5                     | 161-0066-12           |                     |         | 1   | CABLE ASSY, PWR, :3, 18 AWG, 250V, 99.0 L<br>(OPTION A4 NORTH AMERICAN)    | 70903  | CH-77893       |
| -6                     | 131-1345-00           |                     |         | 1   | CONN, RCPT, ELEC: D SERIES, 50 CONT, FEMALE<br>(OPTION 02 ONLY)            | 71468  | DD-50S         |
| -7                     | 131-1319-00           |                     |         | 1   | SHLD, ELEC CONN:<br>(OPTION 02 ONLY)                                       | 71468  | DD51216        |
| -8                     | 195-0993-00           |                     |         | 6   | LEAD, ELECTRICAL: 22 AWG, 15.0 L, 9-4<br>(OPTION 02 ONLY)                  | 80009  | 195-0993-00    |
| -9                     | 175-3301-00           |                     |         | 6   | CABLE ASSY, RF: 50 OHM COAX, 15.0 L, 9-4<br>(OPTION 02 ONLY)               | 80009  | 175-3301-00    |
| -10                    | 214-1593-02           |                     |         | 20  | KEY, CONN PLZN: CKT BOARD CONN<br>(OPTION 02 ONLY)                         | 80009  | 214-1593-02    |