

Technical Reference



TDS 500D, TDS 600C, TDS 700D & TDS 714L Digitizing Oscilloscopes Performance Verification and Specifications

071-0630-03

Copyright © Tektronix, Inc. All rights reserved.

Tektronix products are covered by U.S. and foreign patents, issued and pending. Information in this publication supercedes that in all previously published material. Specifications and price change privileges reserved.

Tektronix, Inc., P.O. Box 500, Beaverton, OR 97077

TEKTRONIX and TEK are registered trademarks of Tektronix, Inc.

WARRANTY

Tektronix warrants that this product will be free from defects in materials and workmanship for a period of three (3) years from the date of shipment. If any such product proves defective during this warranty period, Tektronix, at its option, either will repair the defective product without charge for parts and labor, or will provide a replacement in exchange for the defective product.

In order to obtain service under this warranty, Customer must notify Tektronix of the defect before the expiration of the warranty period and make suitable arrangements for the performance of service. Customer shall be responsible for packaging and shipping the defective product to the service center designated by Tektronix, with shipping charges prepaid. Tektronix shall pay for the return of the product to Customer if the shipment is to a location within the country in which the Tektronix service center is located. Customer shall be responsible for paying all shipping charges, duties, taxes, and any other charges for products returned to any other locations.

This warranty shall not apply to any defect, failure or damage caused by improper use or improper or inadequate maintenance and care. Tektronix shall not be obligated to furnish service under this warranty a) to repair damage resulting from attempts by personnel other than Tektronix representatives to install, repair or service the product; b) to repair damage resulting from improper use or connection to incompatible equipment; or c) to service a product that has been modified or integrated with other products when the effect of such modification or integration increases the time or difficulty of servicing the product.

THIS WARRANTY IS GIVEN BY TEKTRONIX WITH RESPECT TO THIS PRODUCT IN LIEU OF ANY OTHER WARRANTIES, EXPRESSED OR IMPLIED. TEKTRONIX AND ITS VENDORS DISCLAIM ANY IMPLIED WARRANTIES OF MERCHANTABILITY OR FITNESS FOR A PARTICULAR PURPOSE. TEKTRONIX' RESPONSIBILITY TO REPAIR OR REPLACE DEFECTIVE PRODUCTS IS THE SOLE AND EXCLUSIVE REMEDY PROVIDED TO THE CUSTOMER FOR BREACH OF THIS WARRANTY. TEKTRONIX AND ITS VENDORS WILL NOT BE LIABLE FOR ANY INDIRECT, SPECIAL, INCIDENTAL, OR CONSEQUENTIAL DAMAGES IRRESPECTIVE OF WHETHER TEKTRONIX OR THE VENDOR HAS ADVANCE NOTICE OF THE POSSIBILITY OF SUCH DAMAGES.

Table of Contents

General Safety Summary	v
Preface	vii
Contacting Tektronix	viii

Performance Verification Procedures

Input Channels versus Model	1-2
Conventions	1-2
Brief Procedures	1-5
Self Tests	1-5
Functional Tests	1-7
Performance Tests	1-17
Prerequisites	1-17
Equipment Required	1-18
TDS 600C Test Record	1-21
TDS 500D/700D/714L Test Record	1-25
TDS 694C Test Record	1-29
TDS 794D Test Record	1-32
Signal Acquisition System Checks	1-35
Time Base System Checks	1-53
Trigger System Checks	1-59
Output Signal Checks	1-68
Option 05 Video Trigger Checks (Not Available on TDS 694C or TDS 794D)	1-77
Sine Wave Generator Leveling Procedure	1-94
Optical Filter Checks (Options 2C, 3C & 4C Only)	1-97

Specifications

Product Description	2-1
User Interface	2-2
Signal Acquisition System	2-3
Horizontal System	2-3
Trigger System	2-5
Acquisition Control	2-6
On-Board User Assistance	2-7
Measurement Assistance	2-7
Storage	2-8
I/O	2-8
Display	2-9
Nominal Traits	2-11
Warranted Characteristics	2-19
Typical Characteristics	2-29

List of Figures

Figure 1-1: Map of display functions	1-3
Figure 1-2: Verifying adjustments and signal-path compensation ..	1-6
Figure 1-3: Universal test hookup for functional tests – TDS 600C shown	1-8
Figure 1-4: Measurement of DC offset accuracy at zero setting – TDS 684C shown	1-37
Figure 1-5: Initial test hookup	1-38
Figure 1-6: Measurement of DC accuracy at maximum offset and position	1-41
Figure 1-7: Initial test hookup	1-43
Figure 1-8: Optional initial test hookup	1-43
Figure 1-9: Measurement of analog bandwidth	1-46
Figure 1-10: Initial test hookup	1-49
Figure 1-11: Measurement of channel delay – TDS 684C shown	1-51
Figure 1-12: Initial test hookup	1-53
Figure 1-13: Measurement of accuracy – long-term and delay time .	1-55
Figure 1-14: Delta time accuracy test hookup	1-56
Figure 1-15: Initial test hookup	1-60
Figure 1-16: Measurement of time accuracy for pulse and glitch triggering	1-61
Figure 1-17: Initial test hookup	1-64
Figure 1-18: Measurement of trigger sensitivity – 50 MHz results shown on a TDS 684C screen	1-65
Figure 1-19: Initial test hookup	1-68
Figure 1-20: Measurement of main trigger out limits	1-70
Figure 1-21: Initial test hookup	1-73
Figure 1-22: Measurement of probe compensator frequency	1-74
Figure 1-23: Subsequent test hookup	1-75
Figure 1-24: Measurement of probe compensator amplitude	1-76
Figure 1-25: Jitter test hookup	1-78
Figure 1-26: Jitter test displayed waveform – TDS 754D shown	1-79
Figure 1-27: Jitter test when completed – TDS 754D shown	1-80
Figure 1-28: Triggered signal range test – 300 mV	1-81
Figure 1-29: Triggered signal range test – 75 mV	1-82
Figure 1-30: 60 Hz Rejection test hookup	1-83
Figure 1-31: 60 Hz Rejection test setup signal	1-83

Figure 1–32: Subsequent 60 Hz Rejection test hookup	1–84
Figure 1–33: 60 Hz Rejection test result – TDS 684C shown	1–85
Figure 1–34: Line count accuracy test hookup	1–86
Figure 1–35: Line count accuracy test setup waveform – TDS 684C shown	1–87
Figure 1–36: Line count accuracy correct result waveform	1–88
Figure 1–37: Setup for sync duty cycle test	1–90
Figure 1–38: Sync duty cycle test: one-div neg pulse waveform	1–91
Figure 1–39: Sync duty cycle test: critically adjusted pulse	1–92
Figure 1–40: Sine wave generator leveling equipment setup	1–94
Figure 1–41: Equipment setup for maximum amplitude	1–96
Figure 1–42: Reference-receiver performance-verification set up ...	1–99
Figure 1–43: Optical impulse of Ch1 input from OA5022 Optical Attenuator (OIG501 / OIG502 fed into optical attenuator in Step 1)	1–101
Figure 1–44: Optical impulse response for OC–12 SONET Reference Receiver	1–104
Figure 1–45: Optical impulse response for OC–12 SONET Reference Receiver	1–105

List of Tables

Table 1–1: Test equipment	1–18
Table 1–2: DC offset accuracy (zero setting)	1–36
Table 1–3: DC Voltage measurement accuracy	1–40
Table 1–4: Analog bandwidth	1–45
Table 1–5: Delay between channels worksheet	1–52
Table 1–6: Delta time measurement	1–58
Table 1–7: Available filters	1–97
Table 1–8: Reference receiver filter options	1–97
Table 1–9: Option 3C and 4C specifications	1–98
Table 1–10: Available receivers	1–98
Table 1–11: Bessel Thompson frequency response and reference receiver limits	1–106
Table 2–1: Key features of TDS 500D, 600C, 700D and 714L oscilloscopes	2–1
Table 2–2: Record length and divisions per record versus TDS model	2–4
Table 2–3: Nominal traits — Signal acquisition system	2–11
Table 2–4: Nominal traits — Time base system	2–12
Table 2–5: Nominal traits — Triggering system	2–13
Table 2–6: Nominal traits — Display system	2–15
Table 2–7: Nominal traits — GPIB interface, output ports, and power fuse	2–16
Table 2–8: Nominal traits — Data handling and reliability	2–16
Table 2–9: Nominal traits — Mechanical	2–17
Table 2–10: Warranted characteristics — Signal acquisition system	2–20
Table 2–11: Warranted characteristics — Time base system	2–22
Table 2–12: Warranted characteristics — Triggering system	2–23
Table 2–13: Warranted characteristics — Output ports, probe compensator, and power requirements	2–24
Table 2–14: Warranted characteristics — Environmental	2–25
Table 2–15: Certifications and compliances	2–27
Table 2–16: Typical characteristics — Signal acquisition system ...	2–29
Table 2–17: Typical characteristics — Time base system	2–32
Table 2–18: Typical characteristics — Triggering system	2–33

General Safety Summary

Review the following safety precautions to avoid injury and prevent damage to this product or any products connected to it. To avoid potential hazards, use this product only as specified.

Only qualified personnel should perform service procedures.

While using this product, you may need to access other parts of the system. Read the *General Safety Summary* in other system manuals for warnings and cautions related to operating the system.

To Avoid Fire or Personal Injury

Use Proper Power Cord. Use only the power cord specified for this product and certified for the country of use.

Ground the Product. This product is grounded through the grounding conductor of the power cord. To avoid electric shock, the grounding conductor must be connected to earth ground. Before making connections to the input or output terminals of the product, ensure that the product is properly grounded.

Connect and Disconnect Properly. Do not connect or disconnect probes or test leads while they are connected to a voltage source.

Do Not Operate Without Covers. Do not operate this product with covers or panels removed.

Use Proper Fuse. Use only the fuse type and rating specified for this product.

Do Not Operate in Wet/Damp Conditions.

Do Not Operate in an Explosive Atmosphere.

Observe All Terminal Ratings. To avoid fire or shock hazard, observe all ratings and markings on the product. Consult the product manual for further ratings information before making connections to the product.

Do not apply a potential to any terminal, including the common terminal, that exceeds the maximum rating of that terminal.

Use Proper Power Source. Do not operate this product from a power source that applies more than the voltage specified.

Provide Proper Ventilation. Refer to the manual's installation instructions for details on installing the product so it has proper ventilation.

Do Not Operate With Suspected Failures. If you suspect there is damage to this product, have it inspected by qualified service personnel.

**Product Damage
Precautions**

Electrostatic Discharge. Acquisition circuitry in the TDS 694C/794D is very susceptible to damage from electrostatic discharge and from overdrive signals.

To prevent electrostatic damage to the TDS 694C/794D, be sure to operate the oscilloscope only in a static-controlled environment. Be sure to discharge to ground any electrostatic charge that may be present on cables and probes before attaching them to the oscilloscope.

To prevent damage from electrostatic discharge, install short-circuit terminations on unused input connectors. Always use a wrist strap with internal impedance (provided with your instrument) when handling your oscilloscope or making connections.

Symbols and Terms

Terms in this Manual. These terms may appear in this manual:



WARNING. Warning statements identify conditions or practices that could result in injury or loss of life.



CAUTION. Caution statements identify conditions or practices that could result in damage to this product or other property.

Terms on the Product. These terms may appear on the product:

DANGER indicates an injury hazard immediately accessible as you read the marking.

WARNING indicates an injury hazard not immediately accessible as you read the marking.

CAUTION indicates a hazard to property including the product.

Symbols on the Product. The following symbols may appear on the product:



WARNING
High Voltage



Protective Ground
(Earth) Terminal



CAUTION
Refer to Manual



Double
Insulated

**Certifications and
Compliances**

CSA Certified Power Cords. CSA Certification includes the products and power cords appropriate for use in the North America power network. All other power cords supplied are approved for the country of use.

Preface

This is the Performance Verification and Specifications for the TDS 500D, TDS 600C, TDS 700D, and TDS 714L Oscilloscopes. It contains procedures suitable for determining if each instrument functions, was adjusted properly, and meets the performance characteristics as warranted. The following models are covered:

TDS 500:	TDS 520D, TDS 540D and TDS 580D
TDS 600:	TDS 654C, TDS 680C, TDS 684C and TDS 694C
TDS 700:	TDS 714L, TDS 724D, TDS 754D, TDS 784D, and TDS 794D

This document also contains the technical specifications for these oscilloscopes.

Related Manuals

The following documents are related to the use or service of this oscilloscope:

- The *TDS 500D, TDS 600B & TDS 700D User Manual* describes how to use this oscilloscope.
- The *TDS Family Programmer Disk*, included with the *User Manual*, describes using a computer to control the oscilloscope through the GPIB interface.
- The *TDS 500D, TDS 600B & TDS 700D Reference* describes a quick overview of how to operate your oscilloscope.
- The *TDS 500D, TDS 600C, TDS 700D & TDS 714L Service Manual* describes information for maintaining and servicing the oscilloscope to the module level.

Contacting Tektronix

Phone	1-800-833-9200*
Address	Tektronix, Inc. Department or name (if known) 14200 SW Karl Braun Drive P.O. Box 500 Beaverton, OR 97077 USA
Web site	www.tektronix.com
Sales support	1-800-833-9200, select option 1*
Service support	1-800-833-9200, select option 2*
Technical support	Email: techsupport@tektronix.com 1-800-833-9200, select option 3* 1-503-627-2400 6:00 a.m. – 5:00 p.m. Pacific time

* This phone number is toll free in North America. After office hours, please leave a voice mail message. Outside North America, contact a Tektronix sales office or distributor; see the Tektronix web site for a list of offices.



Performance Verification Procedures

Performance Verification Procedures

Two types of Performance Verification procedures can be performed on this product: *Brief Procedures* and *Performance Tests*. You may not need to perform all of these procedures, depending on what you want to accomplish.

- To rapidly confirm that the oscilloscope functions and was adjusted properly, just do the brief procedures under *Self Tests*, which begin on page 1–5.

Advantages: These procedures are quick to do, require no external equipment or signal sources, and perform extensive functional and accuracy testing to provide high confidence that the oscilloscope will perform properly. They can be used as a quick check before making a series of important measurements.

- To further check functionality, first do the *Self Tests* just mentioned; then do the brief procedures under *Functional Tests* that begin on page 1–7.

Advantages: These procedures require minimal additional time to perform, require no additional equipment other than a standard-accessory probe, and more completely test the internal hardware of the oscilloscope. They can be used to quickly determine if the oscilloscope is suitable for putting into service, such as when it is first received.

- If more extensive confirmation of performance is desired, do the *Performance Tests*, beginning on page 1–17, after doing the *Functional* and *Self Tests* just referenced.

Advantages: These procedures add direct checking of warranted specifications. They require more time to perform and suitable test equipment is required. (See *Equipment Required* beginning on page 1–18).

If you are not familiar with operating this oscilloscope, read the oscilloscope reference or user manuals. These contain instructions that will acquaint you with the use of the front-panel controls and the menu system.

Input Channels versus Model

When performing the procedures in this section, be aware that some TDS models refer to input channels Ch 3 and Ch 4 as Aux 1 and Aux 2 respectively. Where appropriate, both names will appear in the procedure, for example, Ch 3 (Aux 1). The channel names for the various TDS models are shown below.

TDS Model	Channel Names
TDS 540D, 580D, 654C, 684C, 694C, 714L, 754D, 784D, and 794D	Ch 1, Ch 2, Ch 3, and Ch 4
TDS 520D, 680C, and 724D	Ch 1, Ch 2, Aux 1, and Aux 2

Conventions

Throughout these procedures the following conventions apply:

- Each test procedure uses the following general format:

Title of Test

Equipment Required

Prerequisites

Procedure

- Each procedure consists of as many steps, substeps, and subparts as required to do the test. Steps, substeps, and subparts are sequenced as follows:

1. First Step

- a. First Substep

- First Subpart

- Second Subpart

- b. Second Substep

2. Second Step

- In steps and substeps, the lead-in statement in italics instructs you what to do, while the instructions that follow tell you how to do it, as in the example step below, “*Initialize the oscilloscope*” by doing “Press save/recall **SETUP**. Now, press the main-menu button...”.

Initialize the oscilloscope: Press save/recall **SETUP**. Now, press the main-menu button **Recall Factory Setup**; then the side-menu button **OK Confirm Factory Init**.

- Where instructed to use a front-panel button or knob, or select from a main or side menu, or verify a readout or status message, the name of the button or knob appears in boldface type: “press **SHIFT**; then **UTILITY**, press the main-menu button **System** until **Cal** is highlighted in the pop-up menu. Verify that the status message is **Pass** in the main menu under the **Voltage Reference** label.”

STOP. The **STOP** notation at the left is accompanied by information you must read to do the procedure properly.

- Refer to Figure 1–1: “Main menu” refers to the menu that labels the seven menu buttons under the display; “side menu” refers to the menu that labels the five buttons to the right of the display. “Pop-up menu” refers to a menu that pops up when a main-menu button is pressed.

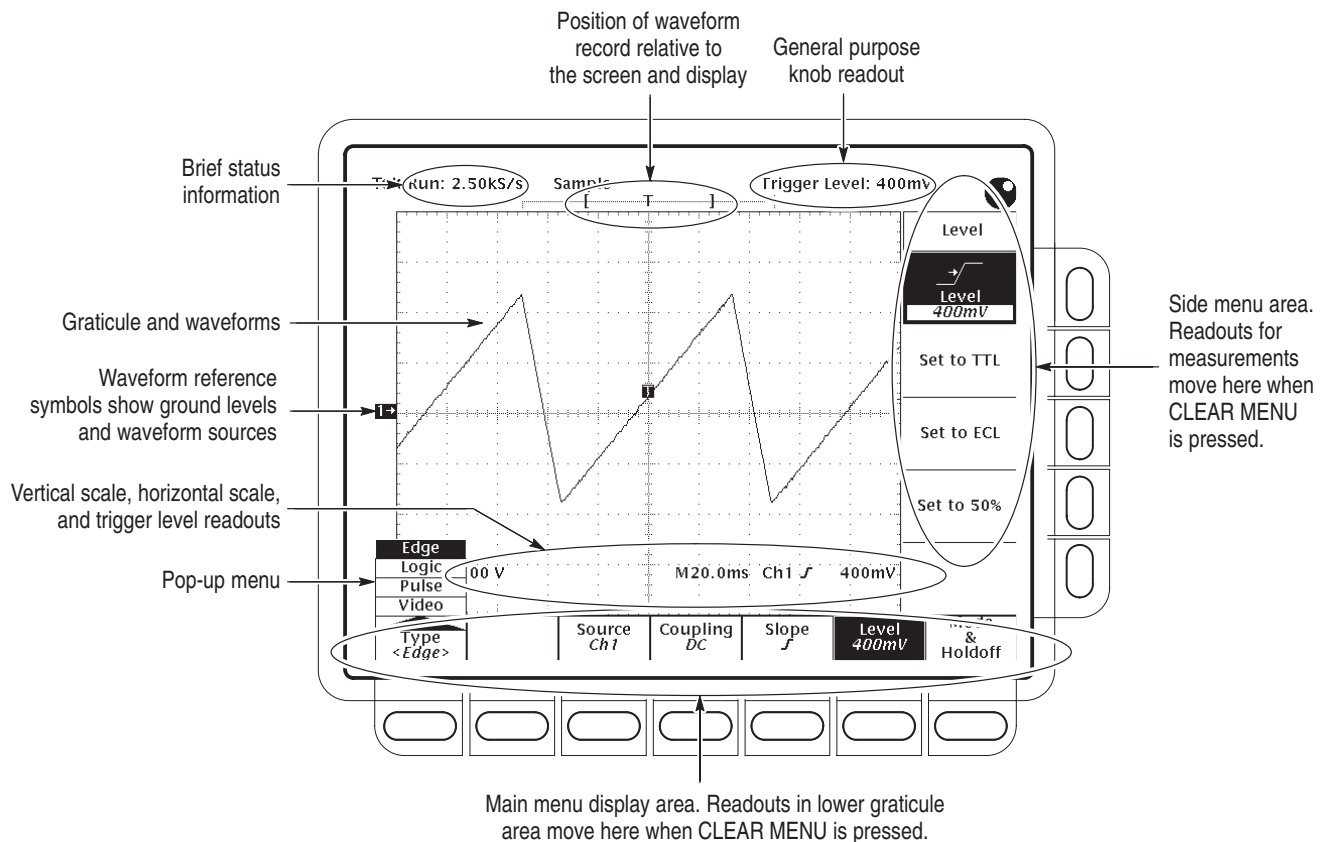

Figure 1–1: Map of display functions

Brief Procedures

The *Self Tests* use internal routines to confirm basic functionality and proper adjustment. No test equipment is required to do these test procedures.

The *Functional Tests* utilize the probe-compensation output at the front panel as a test-signal source for further verifying that the oscilloscope functions properly. A probe is required to do these test procedures.

Self Tests

This procedure uses internal routines to verify that the oscilloscope functions and was adjusted properly. No test equipment or hookups are required.

Verify Internal Adjustment, Self Compensation, and Diagnostics

Equipment required	None
Prerequisites	Power on the oscilloscope and allow a 20 minute warm-up before doing this procedure.

1. *Verify that internal diagnostics pass:* Do the following substeps to verify passing of internal diagnostics.
 - a. *Display the System diagnostics menu:*
 - Press **SHIFT**; then press **UTILITY**.
 - Repeatedly press the main-menu button **System** until **Diag/Err** is highlighted in the pop-up menu.
 - b. *Run the System Diagnostics:*
 - First disconnect any input signals from all four channels.
 - Press the main-menu button **Execute**; then press the side-menu button **OK Confirm Run Test**.
 - c. *Wait:* The internal diagnostics do an exhaustive verification of proper oscilloscope function. This verification will take up to three and a half minutes on some models. When the verification is finished, the resulting status will appear on the screen.
 - d. *Verify that no failures are found and reported on-screen.* If any failures occur do step 1a, then press the main menu button **Error Log** for details.
 - e. *Confirm the three adjustment sections have passed status:*

- Press **SHIFT**; then press **UTILITY**.
 - Highlight **Cal** in the pop-up menu by repeatedly pressing the main-menu button **System**. See Figure 1–2.
 - Verify that the word **Pass** appears in the main menu under the following menu labels: **Voltage Reference**, **Frequency Response**, and **Pulse Trigger**. See Figure 1–2.
- f. *Run the signal-path compensation:* Press the main-menu button **Signal Path**; then press the side-menu button **OK Compensate Signal Paths**.
- g. *Wait:* Signal-path compensation may take five to fifteen minutes to run. While it progresses, a “clock” icon (shown at left) is displayed on-screen. When compensation completes, the status message will be updated to **Pass** or **Fail** in the main menu. See step h.
- h. *Confirm signal-path compensation returns passed status:* Verify that the word **Pass** appears under **Signal Path** in the main menu. See Figure 1–2.

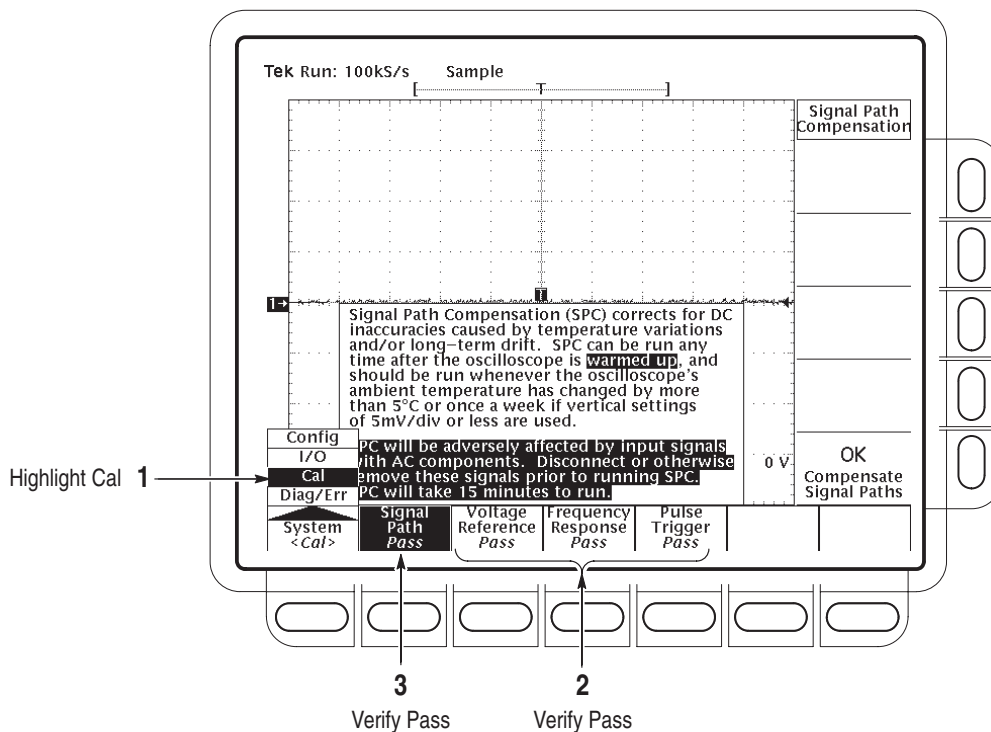

Figure 1–2: Verifying adjustments and signal-path compensation

2. *Return to regular service:* Press **CLEAR MENU** to exit the system menus.

Functional Tests

The purpose of these procedures is to confirm that the oscilloscope functions properly. The only equipment required is one of the standard-accessory probes and, to check the file system, a 3.5 inch, 720 K or 1.44 Mbyte floppy disk.



CAUTION. *The P6243, P6245, P6249 and probes that can be used with this oscilloscope provide an extremely low loading capacitance (<1 pF) to ensure the best possible signal reproduction. These probes should not be used to measure signals exceeding ± 8 volts, or errors in signal measurement will be observed. Above 40 volts, damage to the probe may result. To make measurements beyond ± 10 volts, use either the P6139A probe (good to 500 volts peak), the P6339A probe (for the TDS 694C & TDS 794D), or refer to the catalog for a recommended probe.*

STOP. *These procedures verify functions; that is, they verify that the oscilloscope features operate. They do not verify that they operate within limits.*

Therefore, when the instructions in the functional tests that follow call for you to verify that a signal appears on-screen “that is about five divisions in amplitude” or “has a period of about six horizontal divisions,” etc., do NOT interpret the quantities given as limits. Operation within limits is checked in Performance Tests, which begin on page 1–17.

STOP. *DO NOT make changes to the front-panel settings that are not called out in the procedures. Each verification procedure will require you to set the oscilloscope to certain default settings before verifying functions. If you make changes to these settings, other than those called out in the procedure, you may obtain invalid results. In this case, just redo the procedure from step 1.*

When you are instructed to press a menu button, the button may already be selected (its label will be highlighted). If this is the case, it is not necessary to press the button.

Verify All Input Channels

Equipment required	One probe such as the P6243, P6245, P6249, P6139A ¹ , or P6339A
Prerequisites	None

¹ P6139A probe is not appropriate for the TDS694C/794D oscilloscopes.

1. *Install the test hookup and preset the oscilloscope controls:*
 - a. *Hook up the signal source:* Install the probe on **CH 1**. Connect the probe tip to **PROBE COMPENSATION SIGNAL** on the front panel; connect the probe ground (typically black) to **PROBE COMPENSATION GND**. If using a P6243, P6245 or P6249 probe, you may want to attach a Y-lead connector and two SMD KlipChips as shown in Figure 1–3.

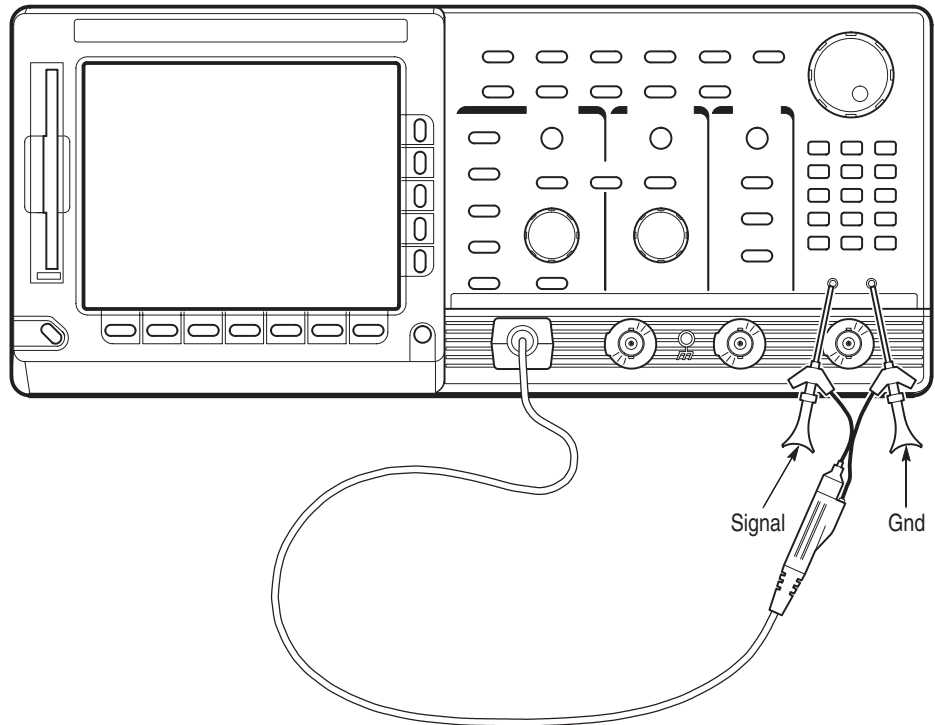

Figure 1–3: Universal test hookup for functional tests – TDS 600C shown

- b. *Initialize the oscilloscope:*
 - Press save/recall **SETUP**.
 - Press the main-menu button **Recall Factory Setup**.
 - Press the side-menu button **OK Confirm Factory Init**.

2. *Verify that all channels operate:* Do the following substeps — test CH 1 first, *skipping substep a and b since CH 1 is already set up for verification and as the trigger source from step 1.*
 - a. *Select an unverified channel:*
 - Press **WAVEFORM OFF** to remove the channel just verified from display.
 - Press the front-panel button that corresponds to the channel you are to verify.
 - Move the probe to the channel you selected.
 - b. *Match the trigger source to the channel selected:*
 - Press **TRIGGER MENU**.
 - Press the main-menu button **Source**.
 - Press the side-menu button that corresponds to the channel selected, **Ch2**, **Ch3**, or **Ch4**. (Some TDS models use **Ax1** and **Ax2** instead of **Ch3** and **Ch4**).
 - c. *Set up the selected channel:*
 - Set the vertical **SCALE** to 200 mV.
 - Set the horizontal **SCALE** to 200 μ s. Press **CLEAR MENU** to remove any menu that may be on the screen.
 - Press **SET LEVEL TO 50%**.
 - d. *Verify that the channel is operational:* Confirm that the following statements are true.
 - The vertical scale readout for the channel under test shows a setting of 200 mV, and a square-wave probe-compensation signal about 2.5 divisions in amplitude is on-screen. See Figure 1–1 on page 1–3 to locate the readout.
 - The vertical **POSITION** knob moves the signal up and down the screen when rotated.
 - Turning the vertical **SCALE** knob counterclockwise decreases the amplitude of the waveform on-screen, turning the knob clockwise increases the amplitude, and returning the knob to 200 mV returns the amplitude to about 2.5 divisions.

- e. *Verify that the channel acquires in all acquisition modes:* Press **SHIFT**; then press **ACQUIRE MENU**. Use the side menu to select, in turn, each of the three hardware acquire modes and confirm that the following statements are true. Refer to the icons at the left of each statement as you confirm those statements.



- Sample mode displays an actively acquiring waveform on-screen. (Note that there is noise present on the peaks of the square wave).



- Peak Detect mode displays an actively acquiring waveform on-screen with the noise present in Sample mode “peak detected.”



- Hi Res mode (TDS 500D and 700D/L only) displays an actively acquiring waveform on-screen with the noise that was present in Sample mode reduced.



- Envelope mode displays an actively acquiring waveform on-screen with the noise displayed.



- Average mode displays an actively acquiring waveform on-screen with the noise reduced.

- f. *Test all channels:* Repeat substeps a through e until all four input channels are verified.

3. *Remove the test hookup:* Disconnect the probe from the channel input and the probe-compensation terminals.

Verify the Time Base

Equipment required	One probe such as the P6243, P6245, P6249, P6139A ¹ , or P6339A
Prerequisites	None

¹ P6139A probe is not appropriate for the TDS694C/794D oscilloscopes.

1. *Install the test hookup and preset the oscilloscope controls:*
 - a. *Hook up the signal source:* Install the probe on **CH 1**. Connect the probe tip to **PROBE COMPENSATION SIGNAL** on the front panel; connect the probe ground to **PROBE COMPENSATION GND**. See Figure 1–3 on page 1–8.
 - b. *Initialize the oscilloscope:*
 - Press save/recall **SETUP**.
 - Press the main-menu button **Recall Factory Setup**; then press the side-menu button **OK Confirm Factory Init**.
 - c. *Modify default settings:*

- Set the vertical **SCALE** to 200 mV.
 - Set the horizontal **SCALE** to 200 μ s.
 - Press **SET LEVEL TO 50%**.
 - Press **CLEAR MENU** to remove the menus from the screen.
2. *Verify that the time base operates:* Confirm the following statements.
 - a. One period of the square-wave probe-compensation signal is about five horizontal divisions on-screen for the 200 μ s horizontal scale setting (set in step 1c).
 - b. Rotating the horizontal **SCALE** knob clockwise expands the waveform on-screen (more horizontal divisions per waveform period), counter-clockwise rotation contracts it, and returning the horizontal scale to 200 μ s returns the period to about five divisions.
 - c. The horizontal **POSITION** knob positions the signal left and right on-screen when rotated.
 3. *Remove the test hookup:* Disconnect the probe from the channel input and the probe-compensation terminals.

Verify the Main and Delayed Trigger Systems

Equipment required	One probe such as the P6243, P6245, P6249, P6139A ¹ , or P6339A
Prerequisites	None

¹ P6139A probe is not appropriate for the TDS694C/794D oscilloscopes.

1. *Install the test hookup and preset the oscilloscope controls:*
 - a. *Hook up the signal source:* Install the probe on **CH 1**. Connect the probe tip to **PROBE COMPENSATION SIGNAL** on the front panel; connect the probe ground to **PROBE COMPENSATION GND**. See Figure 1–3 on page 1–8.
 - b. *Initialize the oscilloscope:*
 - Press save/recall **SETUP**.
 - Press the main-menu button **Recall Factory Setup**.
 - Press the side-menu button **OK Confirm Factory Init**.
 - c. *Modify default settings:*
 - Set the vertical **SCALE** to 200 mV.
 - Set the horizontal **SCALE** for the **M** (main) time base to 200 μ s.

- Press **SET LEVEL TO 50%**.
 - Press **TRIGGER MENU**.
 - Press the main-menu button **Mode & Holdoff**.
 - Press the side-menu button **Normal**.
 - Press **CLEAR MENU** to remove the menus from the screen.
2. *Verify that the main trigger system operates:* Confirm that the following statements are true.
- The trigger level readout for the main trigger system changes with the trigger-**LEVEL** knob.
 - The trigger-**LEVEL** knob can trigger and untrigger the square-wave signal as you rotate it. (Leave the signal *untriggered*, which is indicated by the display not updating).
 - Pressing **SET LEVEL TO 50%** triggers the signal that you just left untriggered. (Leave the signal triggered).
3. *Verify that the delayed trigger system operates:*
- a. *Select the delayed time base:*
- Press **HORIZONTAL MENU**.
 - Press the main-menu button **Time Base**.
 - Press the side-menu button **Delayed Triggerable**; then press the side-menu button **Delayed Only**.
 - Set the horizontal **SCALE** for the **D** (delayed) time base to 200 μ s.
- b. *Select the delayed trigger level menu:*
- Press **SHIFT**; then press **DELAYED TRIG**.
 - Press the main-menu button **Level**; then press the side-menu button **Level**.
- c. *Confirm that the following statements are true:*
- The trigger-level readout for the delayed trigger system changes as you turn the general purpose knob.
 - As you rotate the general purpose knob, the square-wave probe-compensation signal can become triggered and untriggered. (Leave the signal *untriggered*, which is indicated by the display not updating).

- Pressing the side-menu button **Set to 50%** triggers the probe-compensation signal that you just left untriggered. (Leave the signal triggered).
- d. *Verify the delayed trigger counter:*
- Press the main-menu button **Delay by Time**.
 - Use the keypad to enter a delay time of 1 second. Press **1**, then press **ENTER**.
 - Verify that the trigger **READY** indicator on the front panel flashes about once every second as the waveform is updated on-screen.
4. *Remove the test hookup:* Disconnect the probe from the channel input and the probe-compensation terminals.

Verify the File System

Equipment required	One probe such as the P6243, P6245, P6249, P6139A ¹ , or P6339A One 720 K or 1.44 Mbyte, 3.5 inch DOS-compatible disk. You can use a disk of your own or you can use the TDS Family Programmer Disk included in your user manual.
Prerequisites	None

¹ P6139A probe is not appropriate for the TDS694C/794D oscilloscopes.

1. *Install the test hookup and preset the oscilloscope controls:*
- a. *Hook up the signal source:* Install the probe on **CH 1**. Connect the probe tip to **PROBE COMPENSATION SIGNAL** on the front panel; connect the probe ground to **PROBE COMPENSATION GND**. See Figure 1–3 on page 1–8.
 - b. *Insert the test disk:* Insert the floppy disk in the floppy disk drive to the left of the monitor.
 - Position the disk so the metal shutter faces the drive.
 - Position the disk so the stamped arrow is on the top right side. In other words, place the angled corner in the front bottom location.
 - Push the disk into the drive until it goes all the way in and clicks into place.
 - c. *Initialize the oscilloscope:*
 - Press save/recall **SETUP**.
 - Press the main-menu button **Recall Factory Setup**.
 - Press the side-menu button **OK Confirm Factory Init**.

d. *Modify default settings:*

- Set the vertical **SCALE** to 200 mV.
- Set the horizontal **SCALE** for the **M** (main) time base to 200 μ s. Notice the waveform on the display now shows two cycles instead of five.
- Press **SET LEVEL TO 50%**.
- Press **CLEAR MENU** to remove the menus from the screen.

e. *Save the settings:*

- Press **SETUP**.
- Press the main-menu button **Save Current Setup**; then press the side-menu button **To File**.
- Turn the general purpose knob to select the file to save. Choose **TEK?????.SET** (or **fd0:**, the floppy disk drive, **hd0:**, the optional hard disk drive, or **Zip:**, if an external Zip drive is connected). With this choice, you will save a file starting with **TEK**, then containing 5-numbers, and a **.SET** extension. For example, the first time you run this on a blank, formatted disk or on the Example Programs Disk, the oscilloscope will assign the name **TEK00000.SET** to your file. If you ran the procedure again, the oscilloscope would increment the name and call the file **TEK00001.SET**.

NOTE. *If testing an external Zip drive, it must first be connected to the oscilloscope, then be powered on simultaneously with the oscilloscope, or immediately after the oscilloscope is powered-on. This ensures proper communications are set up between the oscilloscope and the Zip drive.*

- f. To test the optional hard disk drive or external Zip drive, choose either the hard disk drive (**hd0:**), or the external Zip drive (**Zip:**). Then use the general purpose knob to select the file to save. Save the file as in step e.
- Press the side-menu button **Save To Selected File**.

2. *Verify the file system works:*

- Press the main-menu button **Recall Factory Setup** and the side-menu button **OK Confirm Factory Init** to restore the 500 μ s time base and the five cycle waveform.
- Press the main-menu button **Recall Saved Setup**; then press the side-menu button **From File**.

- Turn the general purpose knob to select the file to recall. For example, if you followed the instructions previously and saved the file to either the floppy disk drive (**fd0:**), or the optional hard disk drive (**hd0:**), you had the oscilloscope assign the name TEK00000.SET to your file.
 - Press the side-menu button **Recall From Selected File**.
 - Verify that the oscilloscope retrieved the saved setup from the disk. Do this by noticing the horizontal **SCALE** for the **M** (main) time base is again 200 μ s and the waveform shows only two cycles just as it was when you saved the setup.
3. *Remove the test hookup:*
- Disconnect the probe from the channel input and the probe-compensation terminals.
 - Remove the floppy disk from the floppy disk drive.

Performance Tests

This section contains a collection of procedures for checking that the TDS 500D, TDS 600C, TDS 700D, and TDS 714L Oscilloscopes perform as warranted.

The procedures are arranged in four logical groupings: *Signal Acquisition System Checks*, *Time Base System Checks*, *Triggering System Checks*, and *Output Ports Checks*. They check all the characteristics that are designated as checked in *Specifications*. (The characteristics that are checked appear in **boldface** type under *Warranted Characteristics in Specifications*).

STOP. *These procedures extend the confidence level provided by the basic procedures described on page 1–5. The basic procedures should be done first, then these procedures performed if desired.*

Prerequisites

The tests in this section comprise an extensive, valid confirmation of performance and functionality when the following requirements are met:

- The cabinet must be installed on the oscilloscope.
- You must have performed and passed the procedures under *Self Tests*, found on page 1–5, and those under *Functional Tests*, found on page 1–7.
- A signal-path compensation must have been done within the recommended calibration interval and at a temperature within $\pm 5^{\circ}$ C of the present operating temperature. (If at the time you did the prerequisite *Self Tests*, the temperature was within the limits just stated, consider this prerequisite met).
- The oscilloscope must have been last adjusted at an ambient temperature between $+20^{\circ}$ C and $+30^{\circ}$ C, must have been operating for a warm-up period of at least 20 minutes, and must be operating at an ambient temperatures as follows: $+4^{\circ}$ C to $+40^{\circ}$ C for the TDS 694C, $+4^{\circ}$ C to $+45^{\circ}$ C for other TDS 600C and 0° C to $+50^{\circ}$ C for the TDS 500D, TDS 700D, and TDS 714L. (The warm-up requirement is usually met in the course of meeting the Self Tests and Functional Tests prerequisites listed above).

Equipment Required

Procedures starting on page 1–35, use external, traceable signal sources to directly check warranted characteristics. Table 1–1 lists the required equipment.

Table 1–1: Test equipment

Item number and description	Minimum requirements	Example	Purpose
1. Attenuator, 10X (two required)	Ratio: 10X; impedance 50 Ω ; connectors: female BNC input, male BNC output	Tektronix part number 011-0059-02	Signal Attenuation
2. Attenuator, 5X	Ratio: 5X; impedance 50 Ω ; connectors: female BNC input, male BNC output	Tektronix part number 011-0060-02	Signal Attenuation
3. Adapter, BNC female-to-Clip Leads	BNC female-to-Clip Leads	Tektronix part number 013-0076-00	Signal Coupling for Probe Compensator Output Check
4. Terminator, 50 Ω	Impedance 50 Ω ; connectors: female BNC input, male BNC output	Tektronix part number 011-0049-01	Signal Termination for Channel Delay Test
5. Cable, Precision 50 Ω Coaxial (three required)	50 Ω , 36 in, male-to-male BNC connectors	Tektronix part number 012-0482-00	Signal Interconnection
6. Connector, Dual-Banana (two required)	Female BNC-to-dual banana	Tektronix part number 103-0090-00	Various Accuracy Tests
7. Connector, BNC “T”	Male BNC-to-dual female BNC	Tektronix part number 103-0030-00	Checking Trigger Sensitivity
8. Coupler, Dual-Input	Female BNC-to-dual male BNC	Tektronix part number 067-0525-02	Checking Delay Between Channels
9. Generator, DC Calibration	Variable amplitude to ± 104 V; accuracy to 0.1%	Data Precision 8200 ¹	Checking DC Offset, Gain, and Measurement Accuracy
10. Generator, Calibration	500 mV square wave calibrator amplitude; accuracy to 0.25%	Tegam/Tektronix PG 506A Calibration Generator ^{1,3}	To check accuracy of CH 3 Signal Out
11. Generator, Time Mark (optional)	Variable marker frequency from 10 ms to 10 ns; accuracy within 2 ppm	Tegam/Tektronix TG 501A Time Mark Generator ^{1,3}	Checking Sample-Rate and Delay-time Accuracy
12. Probe, 10X	A P6139A ² , P6243, P6249, P6245, or P6339A probe ⁴	Tektronix part number P6139A or P6245	Signal Interconnection
13. 3.5 inch, 720 K or 1.44 Mbyte, DOS-compatible floppy disk		TDS Family Programmer Disk (Tektronix part number 063-3120-00), included with User Manual (Tektronix part number 071-0130-XX)	Checking File System Basic Functionality
14. Generator, Sine Wave	250 kHz to at least 500 MHz (higher for higher-bandwidth scopes). Variable amplitude from 60 mV to 2 V _{p-p} into 50 Ω . Frequency error >2.0%	Rohde & Schwarz SMT or SMY ^{1,5}	Checking Analog Bandwidth, Trigger Sensitivity, Sample-rate, External Clock, and Delay-Time Accuracy

Table 1–1: Test equipment (cont.)

Item number and description	Minimum requirements	Example	Purpose
15. Meter, Level and Power Sensor	Frequency range: 10 MHz to the oscilloscope bandwidth. Amplitude range: $6 \text{ mV}_{\text{p-p}}$ to $2 \text{ V}_{\text{p-p}}$	Rohde & Schwarz URV 35, with NRV-Z8 power sensor ^{1,5}	Checking Analog Bandwidth and Trigger Sensitivity
16. Splitter, Power	Frequency range: DC to 3 GHz. Tracking: >2.0%	Tektronix part number ^{1,5} 015-0565-00	Checking Analog Bandwidth
17. Adapter (four required)	Male N-to-female BNC	Tektronix part number 103-0045-00	Checking Analog Bandwidth
18. Adapter	Female N-to-male BNC	Tektronix part number 103-0058-00	Checking Analog Bandwidth
19. Adapter	3 SMA male-to-male	Tektronix part number 015-1012-00	Checking the delay between channels
20. Adapter	3 SMA female-to-male BNC	Tektronix part number 015-1018-00	Checking the delay between channels
21. Generator, Video Signal	Provides PAL compatible outputs	Tektronix TSG 121	Used to Test Video Option 05 Equipped Instruments Only
22. Oscillator, Leveled Sine wave Generator	60 Hz Sine wave	Tegam/Tektronix SG 502 (if available) ^{1,3}	Used to Test Video Option 05 Equipped Instruments Only
23. Pulse Generator		Tektronix CFG280 (or Tegam/Tektronix PG 502) ³	Used to Test Video Option 05 Equipped Instruments Only
24. Cable, Coaxial (two required)	75 Ω , 36 in, male-to-male BNC connectors	Tektronix part number 012-1338-00	Used to Test Video Option 05 Equipped Instruments Only
25. Terminator, 75 Ω (two required)	Impedance 75 Ω ; connectors: female BNC input, male BNC output	Tektronix part number 011-0102-01	Used to Test Video Option 05 Equipped Instruments Only
26. Generator, Optical Impulse	850 nm optical impulse	Tektronix OIG501 Optical Impulse Generator ³	Checking Option 3C
27. Generator, Optical Impulse	1300 nm optical impulse	Tektronix OIG502 Optical Impulse Generator ³	Checking Option 4C
28. Cable, Coaxial (two required)	50 Ω , 20 in, male-to-male SMA connectors	Tektronix part number 174-1427-00	Used to Test Delta Time Measurement Accuracy
29. Adapter	SMA "T", male to 2 SMA female	Tektronix part number 015-1016-00	Used to Test Delta Time Measurement Accuracy
30. Adapter	SMA female to BNC male	Tektronix part number 015-0572-00	Used to Test Delta Time Measurement Accuracy
31. Adapter	BNC male to female elbow	Tektronix part number 103-0031-00	Used to Test Delta Time Measurement Accuracy
32. Terminator	Short circuit, SMA connector	Tektronix part number 015-1021-00	Used to Test Delta Time Measurement Accuracy
33. Attenuator, 2X	Ratio: 2X; impedance 50 Ω ; connectors: female BNC input, male BNC output	Tektronix part number 011-0069-02	Used to Test Delta Time Measurement Accuracy

Table 1–1: Test equipment (cont.)

Item number and description	Minimum requirements	Example	Purpose
34. Attenuator, Optical	62.5 micron optical attenuator	Tektronix OA5022 Optical Attenuator ³	Checking Option 3C and 4C
35. Cable, Fiber Optic	FC-FC fiber cable	Tektronix part number 174-2322-00	Checking Option 3C and 4C
36. Optical-to-Electrical Converter	P6701B (used with Option 3C) or P6703B (used with Option 4C) optical-to-electrical converter	Tektronix part number P6701B or P6703B	Checking Option 3C and 4C

- ¹ You may replace items 9, 10, 11, 14, 15, 16, and 22 with a Wavetek 9100 (with options 100 and 600) for 500 MHz oscilloscopes, or a Wavetek 9500 (with option 100) and output head appropriate for the bandwidth of the oscilloscope(s) being tested. For 3 GHz oscilloscopes use a Wavetek 9530 head.
- ² P6139A probe is not appropriate for the TDS694C/794D oscilloscopes.
- ³ Requires a TM 500 or TM 5000 Series Power Module Mainframe. For Delta Time Measurement Accuracy use a Wavetek 9500 or a pulse generator with a rise time as shown in Table 1–6 on page 1–58.
- ⁴ **Warning:** The P6243 and P6245 probes that may be used with this oscilloscope provide an extremely low loading capacitance (<1 pF) to ensure the best possible signal reproduction. These probes should not be used to measure signals exceeding ± 8 V, or errors in signal measurement will be observed. Above 40 V, damage to the probe may result. To make measurements beyond ± 8 V, use either the P6139A probe (good to 500 V), or refer to the catalog for a recommended probe. P6139A is not an appropriate probe for the TDS 694C or TDS 794D oscilloscopes.
- ⁵ If available, you may replace items 14, 15, and 16 with the following set of equipment for bandwidths up to 1 GHz: a Tegam/Tektronix SG503 and SG504 with SG504 leveling head.

TDS 600C Test Record

Photocopy this and the next three pages and use them to record the performance test results for your TDS 600C. The TDS 694C Test Record begins on page 1–29.

TDS 600C Test Record

Instrument Serial Number: _____ Certificate Number: _____
 Temperature: _____ RH %: _____
 Date of Calibration: _____ Technician: _____

TDS 600C Performance Test		Minimum	Incoming	Outgoing	Maximum
Offset Accuracy					
CH1 Offset	+1 mV	- 2.1 mV	_____	_____	+ 2.1 mV
	+101 mV	- 75.6 mV	_____	_____	+ 75.6 mV
	+1.01 V	- 756 mV	_____	_____	+ 756 mV
CH2 Offset	+1 mV	- 2.1 mV	_____	_____	+ 2.1 mV
	+101 mV	- 75.6 mV	_____	_____	+ 75.6 mV
	+1.01 V	- 756 mV	_____	_____	+ 756 mV
CH3 or AX1 Offset	+1 mV	- 2.1 mV	_____	_____	+ 2.1 mV
	+101 mV	- 75.6 mV	_____	_____	+ 75.6 mV
	+1.01 V	- 756 mV	_____	_____	+ 756 mV
CH4 or AX2 Offset	+1 mV	- 2.1 mV	_____	_____	+ 2.1 mV
	+101 mV	- 75.6 mV	_____	_____	+ 75.6 mV
	+1.01 V	- 756 mV	_____	_____	+ 756 mV
DC Voltage Measurement Accuracy (Averaged)					
CH1	5 mV Vert scale setting, -5 Div position setting, +1 V offset	+ 1.0329 V	_____	_____	+ 1.0471 V
CH1	5 mV Vert scale setting, +5 Div position setting, -1 V offset	- 1.0471 V	_____	_____	- 1.0329 V
CH1	200 mV Vert scale setting, -5 Div position setting, +10 V offset	+ 11.4165 V	_____	_____	+ 11.7835 V
CH1	200 mV Vert scale setting, +5 Div position setting, -10 V offset	- 11.7835 V	_____	_____	- 11.4165 V
CH1	1.01 V Vert scale setting, -5 Div position setting, +10 V offset	+ 17.102 V	_____	_____	+ 18.899 V
CH1	1.01 V Vert scale setting, +5 Div position setting, -10 V offset	- 18.899 V	_____	_____	- 17.102 V
CH2	5 mV Vert scale setting, -5 Div position setting, +1 V offset	+ 1.0329 V	_____	_____	+ 1.0471 V
CH2	5 mV Vert scale setting, +5 Div position setting, -1 V offset	- 1.0471 V	_____	_____	- 1.0329 V
CH2	200 mV Vert scale setting, -5 Div position setting, +10 V offset	+ 11.4165 V	_____	_____	+ 11.7835 V

TDS 600C Test Record (cont.)

Instrument Serial Number: _____ Certificate Number: _____
 Temperature: _____ RH %: _____
 Date of Calibration: _____ Technician: _____

TDS 600C Performance Test		Minimum	Incoming	Outgoing	Maximum
CH2	200 mV Vert scale setting, +5 Div position setting, -10 V offset	- 11.7835 V	_____	_____	- 11.4165 V
CH2	1.01 V Vert scale setting, -5 Div position setting, +10 V offset	+ 17.102 V	_____	_____	+ 18.899 V
CH2	1.01 V Vert scale setting, +5 Div position setting, -10 V offset	- 18.899 V	_____	_____	- 17.102 V
CH3 or AX1	5 mV Vert scale setting, -5 Div position setting, +1 V offset	+ 1.0329 V	_____	_____	+ 1.0471 V
CH3 or AX1	5 mV Vert scale setting, +5 Div position setting, -1 V offset	- 1.0471 V	_____	_____	- 1.0329 V
CH3 or AX1	200 mV Vert scale setting, -5 Div position setting, +10 V offset	+ 11.4165 V	_____	_____	+ 11.7835 V
CH3 or AX1	200 mV Vert scale setting, +5 Div position setting, -10 V offset	- 11.7835 V	_____	_____	- 11.4165 V
CH3 or AX1	1.01 V Vert scale setting, -5 Div position setting, +10 V offset	+ 17.102 V	_____	_____	+ 18.899 V
CH3 or AX1	1.01 V Vert scale setting, +5 Div position setting, -10 V offset	- 18.899 V	_____	_____	- 17.102 V
CH4 or AX2	5 mV Vert scale setting, -5 Div position setting, +1 V offset	+ 1.0329 V	_____	_____	+ 1.0471 V
CH4 or AX2	5 mV Vert scale setting, +5 Div position setting, -1 V offset	- 1.0471 V	_____	_____	- 1.0329 V
CH4 or AX2	200 mV Vert scale setting, -5 Div position setting, +10 V offset	+ 11.4165 V	_____	_____	+ 11.7835 V
CH4 or AX2	200 mV Vert scale setting, +5 Div position setting, -10 V offset	- 11.7835 V	_____	_____	- 11.4165 V
CH4 or AX2	1.01 V Vert scale setting, -5 Div position setting, +10 V offset	+ 17.102 V	_____	_____	+ 18.899 V
CH4 or AX2	1.01 V Vert scale setting, +5 Div position setting, -10 V offset	- 18.899 V	_____	_____	- 17.102 V

Analog Bandwidth

CH1	100 mV	424 mV	_____	_____	N/A
CH2	100 mV	424 mV	_____	_____	N/A
CH3 or AX1	100 mV	424 mV	_____	_____	N/A
CH4 or AX2	100 mV	424 mV	_____	_____	N/A

TDS 600C Test Record (cont.)

Instrument Serial Number: _____ Certificate Number: _____
 Temperature: _____ RH %: _____
 Date of Calibration: _____ Technician: _____

TDS 600C Performance Test	Minimum	Incoming	Outgoing	Maximum
Delay Between Channels				
Delay Between Channels	N/A	_____	_____	100 ps
Time Base System				
Long Term Sample Rate/ Delay Time @ 500 ns/10 ms	-2.0 Div	_____	_____	+2.0 Div
Trigger System Accuracy				
Pulse-Glitch or Pulse-Width, Hor. scale $\leq 1 \mu\text{s}$				
Lower Limit	3.5 ns	_____	_____	6.5 ns
Upper Limit	3.5 ns	_____	_____	6.5 ns
Pulse-Glitch or Pulse-Width, Hor. scale $> 1 \mu\text{s}$				
Lower Limit	1.9 μs	_____	_____	2.1 μs
Upper Limit	1.9 μs	_____	_____	2.1 μs
CH1 Sensitivity, 50 MHz, Main	Pass/Fail	_____	_____	Pass/Fail
CH1 Sensitivity, 50 MHz, Delayed	Pass/Fail	_____	_____	Pass/Fail
CH1 AUX Trigger Input	Pass/Fail	_____	_____	Pass/Fail
CH1 Sensitivity, 1 GHz, Main	Pass/Fail	_____	_____	Pass/Fail
CH1 Sensitivity, 1 GHz, Delayed	Pass/Fail	_____	_____	Pass/Fail
Output Signal Checks				
MAIN TRIGGER OUTPUT, 1 M Ω				
High	High $\geq 2.5 \text{ V}$	_____	_____	Low $\leq 0.7 \text{ V}$
Low		_____	_____	
MAIN TRIGGER OUTPUT, 50 Ω				
High	High $\geq 1.0 \text{ V}$	_____	_____	Low $\leq 0.25 \text{ V}$
Low		_____	_____	
DELAYED TRIGGER OUTPUT, 50 Ω				
High	High $\geq 1.0 \text{ V}$	_____	_____	Low $\leq 0.25 \text{ V}$
Low		_____	_____	
DELAYED TRIGGER OUTPUT, 1 M Ω				
High	High $\geq 2.5 \text{ V}$	_____	_____	Low $\leq 0.7 \text{ V}$
Low		_____	_____	

TDS 600C Test Record (cont.)

Instrument Serial Number: _____ Certificate Number: _____
 Temperature: _____ RH %: _____
 Date of Calibration: _____ Technician: _____

TDS 600C Performance Test	Minimum	Incoming	Outgoing	Maximum
CH 3 or AX1 SIGNAL OUTPUT, 1 M Ω	p-p \geq 80 mV	_____	_____	p-p \leq 120 mV
CH 3 or AX1 SIGNAL OUTPUT, 50 Ω	p-p \geq 40 mV	_____	_____	p-p \leq 60 mV
Probe Compensator Output Signal				
Frequency (CH1 Freq).	950 Hz	_____	_____	1.050 kHz
Voltage (difference)	495 mV	_____	_____	505 mV

TDS 500D/700D/714L Test Record

Photocopy this and the next three pages and use them to record the performance test results for your TDS 500D/700D/714L. The TDS 794D Test Record begins on page 1–32.

TDS 500D/700D/714L Test Record

Instrument Serial Number: _____ Certificate Number: _____
 Temperature: _____ RH %: _____
 Date of Calibration: _____ Technician: _____

TDS 500D/700D/714L Performance Test		Minimum	Incoming	Outgoing	Maximum
Offset Accuracy					
CH1 Offset	+1 mV	- 1.6 mV	_____	_____	+ 1.6 mV
	+101 mV	- 25.1 mV	_____	_____	+ 25.1 mV
	+1.01 V	- 251 mV	_____	_____	+ 251 mV
CH2 Offset	+1 mV	- 1.6 mV	_____	_____	+ 1.6 mV
	+101 mV	- 25.1 mV	_____	_____	+ 25.1 mV
	+1.01 V	- 251 mV	_____	_____	+ 251 mV
CH3 or AX1 Offset	+1 mV	- 1.6 mV	_____	_____	+ 1.6 mV
	+101 mV	- 25.1 mV	_____	_____	+ 25.1 mV
	+1.01 V	- 251 mV	_____	_____	+ 251 mV
CH4 or AX2 Offset	+1 mV	- 1.6 mV	_____	_____	+ 1.6 mV
	+101 mV	- 25.1 mV	_____	_____	+ 25.1 mV
	+1.01 V	- 251 mV	_____	_____	+ 251 mV
DC Voltage Measurement Accuracy (Averaged)					
CH1	5 mV Vert scale setting, -5 Div position setting, +1 V offset	+ 1.0355 V	_____	_____	+ 1.0445 V
CH1	5 mV Vert scale setting, +5 Div position setting, -1 V offset	- 1.0445 V	_____	_____	- 1.0355 V
CH1	200 mV Vert scale setting, -5 Div position setting, +10 V offset	+ 11.5195 V	_____	_____	+ 11.6805 V
CH1	200 mV Vert scale setting, +5 Div position setting, -10 V offset	- 11.6805 V	_____	_____	- 11.5195 V
CH1	1.01 V Vert scale setting, -5 Div position setting, +10 V offset	+ 17.621 V	_____	_____	+ 18.379 V
CH1	1.01 V Vert scale setting, +5 Div position setting, -10 V offset	- 18.379 V	_____	_____	- 17.621 V
CH2	5 mV Vert scale setting, -5 Div position setting, +1 V offset	+ 1.0355 V	_____	_____	+ 1.0445 V
CH2	5 mV Vert scale setting, +5 Div position setting, -1 V offset	- 1.0445 V	_____	_____	- 1.0355 V
CH2	200 mV Vert scale setting, -5 Div position setting, +10 V offset	+ 11.5195 V	_____	_____	+ 11.6805 V

TDS 500D/700D/714L Test Record (cont.)

Instrument Serial Number: _____ Certificate Number: _____
 Temperature: _____ RH %: _____
 Date of Calibration: _____ Technician: _____

TDS 500D/700D/714L Performance Test		Minimum	Incoming	Outgoing	Maximum
CH2	200 mV Vert scale setting, +5 Div position setting, -10 V offset	- 11.6805 V	_____	_____	- 11.5195 V
CH2	1.01 V Vert scale setting, -5 Div position setting, +10 V offset	+ 17.621 V	_____	_____	+ 18.379 V
CH2	1.01 V Vert scale setting, +5 Div position setting, -10 V offset	- 18.379 V	_____	_____	- 17.621 V
CH3 or AX1	5 mV Vert scale setting, -5 Div position setting, +1 V offset	+ 1.0355 V	_____	_____	+ 1.0445 V
CH3 or AX1	5 mV Vert scale setting, +5 Div position setting, -1 V offset	- 1.0445 V	_____	_____	- 1.0355 V
CH3 or AX1	200 mV Vert scale setting, -5 Div position setting, +10 V offset	+ 11.5195 V	_____	_____	+ 11.6805 V
CH3 or AX1	200 mV Vert scale setting, +5 Div position setting, -10 V offset	- 11.6805 V	_____	_____	- 11.5195 V
CH3 or AX1	1.01 V Vert scale setting, -5 Div position setting, +10 V offset	+ 17.621 V	_____	_____	+ 18.379 V
CH3 or AX1	1.01 V Vert scale setting, +5 Div position setting, -10 V offset	- 18.379 V	_____	_____	- 17.621 V
CH4 or AX2	5 mV Vert scale setting, -5 Div position setting, +1 V offset	+ 1.0355 V	_____	_____	+ 1.0445 V
CH4 or AX2	5 mV Vert scale setting, +5 Div position setting, -1 V offset	- 1.0445 V	_____	_____	- 1.0355 V
CH4 or AX2	200 mV Vert scale setting, -5 Div position setting, +10 V offset	+ 11.5195 V	_____	_____	+ 11.6805 V
CH4 or AX2	200 mV Vert scale setting, +5 Div position setting, -10 V offset	- 11.6805 V	_____	_____	- 11.5195 V
CH4 or AX2	1.01 V Vert scale setting, -5 Div position setting, +10 V offset	+ 17.621 V	_____	_____	+ 18.379 V
CH4 or AX2	1.01 V Vert scale setting, +5 Div position setting, -10 V offset	- 18.379 V	_____	_____	- 17.621 V

Analog Bandwidth

CH1	100 mV	424 mV	_____	_____	N/A
CH2	100 mV	424 mV	_____	_____	N/A
CH3 or AX1	100 mV	424 mV	_____	_____	N/A
CH4 or AX2	100 mV	424 mV	_____	_____	N/A

TDS 500D/700D/714L Test Record (cont.)

Instrument Serial Number: _____ Certificate Number: _____
 Temperature: _____ RH %: _____
 Date of Calibration: _____ Technician: _____

TDS 500D/700D/714L Performance Test	Minimum	Incoming	Outgoing	Maximum
Delay Between Channels	N/A	_____	_____	50 ps
Time Base System				
Long Term Sample Rate/ Delay Time @ 100 ns/10.0 ms	-2.5 Div	_____	_____	+2.5 Div
Trigger System Accuracy				
Pulse-Glitch or Pulse-Width, Hor. scale $\leq 1 \mu\text{s}$				
Lower Limit	3.5 ns	_____	_____	6.5 ns
Upper Limit	3.5 ns	_____	_____	6.5 ns
Pulse-Glitch or Pulse-Width, Hor. scale $> 1 \mu\text{s}$				
Lower Limit	1.9 μs	_____	_____	2.1 μs
Upper Limit	1.9 μs	_____	_____	2.1 μs
CH1 Sensitivity, 50 MHz, Main	Pass/Fail	_____	_____	Pass/Fail
CH1 Sensitivity, 50 MHz, Delayed	Pass/Fail	_____	_____	Pass/Fail
CH1 AUX Trigger Input	Pass/Fail	_____	_____	Pass/Fail
CH1 Sensitivity, full bandwidth, Main	Pass/Fail	_____	_____	Pass/Fail
CH1 Sensitivity, full bandwidth, Delayed	Pass/Fail	_____	_____	Pass/Fail
Output Signal Checks				
MAIN TRIGGER OUTPUT, 1 M Ω				
High	High $\geq 2.5 \text{ V}$	_____	_____	Low $\leq 0.7 \text{ V}$
Low		_____	_____	
MAIN TRIGGER OUTPUT, 50 Ω				
High	High $\geq 1.0 \text{ V}$	_____	_____	Low $\leq 0.25 \text{ V}$
Low		_____	_____	
DELAYED TRIGGER OUTPUT, 50 Ω				
High	High $\geq 1.0 \text{ V}$	_____	_____	Low $\leq 0.25 \text{ V}$
Low		_____	_____	
DELAYED TRIGGER OUTPUT, 1 M Ω				
High	High $\geq 2.5 \text{ V}$	_____	_____	Low $\leq 0.7 \text{ V}$
Low		_____	_____	

TDS 500D/700D/714L Test Record (cont.)

Instrument Serial Number: _____ Certificate Number: _____
 Temperature: _____ RH %: _____
 Date of Calibration: _____ Technician: _____

TDS 500D/700D/714L Performance Test	Minimum	Incoming	Outgoing	Maximum
CH 3 or AX 1 SIGNAL OUTPUT, 1 MΩ	p-p ≥ 88 mV	_____	_____	p-p ≤ 132 mV
CH 3 or AX 1 SIGNAL OUTPUT, 50 Ω	p-p ≥ 44 mV	_____	_____	p-p ≤ 66 mV
Probe Compensator Output Signal				
Frequency (CH1 Freq).	950 Hz	_____	_____	1.050 kHz
Voltage (difference)	495 mV	_____	_____	505 mV

TDS694C Test Record

Photocopy this and the next two pages and use them to record the performance test results for your TDS694C.

TDS694C Test Record

Instrument Serial Number: _____ Certificate Number: _____
 Temperature: _____ RH %: _____
 Date of Calibration: _____ Technician: _____

TDS694C Performance Test		Minimum	Incoming	Outgoing	Maximum
Offset Accuracy					
CH1 Offset	+10 mV	-2.5 mV	_____	_____	+2.5 mV
	+101 mV	-25.1 mV	_____	_____	+25.1 mV
CH2 Offset	+10 mV	-2.5 mV	_____	_____	+2.5 mV
	+101 mV	-25.1 mV	_____	_____	+25.1 mV
CH3 Offset	+10 mV	-2.5 mV	_____	_____	+2.5 mV
	+101 mV	-25.1 mV	_____	_____	+25.1 mV
CH4 Offset	+10 mV	-2.5 mV	_____	_____	+2.5 mV
	+101 mV	-25.1 mV	_____	_____	+25.1 mV
DC Voltage Measurement Accuracy (Averaged)					
CH1	10 mV Vert scale setting, -5 Div position setting, +.5 V offset	+0.5755 V	_____	_____	+0.5845 V
CH1	10 mV Vert scale setting, +5 Div position setting, -.5 V offset	-0.5845 V	_____	_____	-0.5755 V
CH1	200 mV Vert scale setting, 0 Div position setting, +5 V offset	+4.828 V	_____	_____	+5.172 V
CH1	200 mV Vert scale setting, 0 Div position setting, -5 V offset	-5.172 V	_____	_____	-4.828 V
CH1	1 V Vert scale setting, 0 Div position setting, +2.5 V offset	+4.738 V	_____	_____	+5.263 V
CH1	1 V Vert scale setting, 0 Div position setting, -2.5 V offset	-5.263 V	_____	_____	-4.738 V
CH2	10 mV Vert scale setting, -5 Div position setting, +.5 V offset	+0.5755 V	_____	_____	+0.5845 V
CH2	10 mV Vert scale setting, +5 Div position setting, -.5 V offset	-0.5845 V	_____	_____	-0.5755 V
CH2	200 mV Vert scale setting, 0 Div position setting, +5 V offset	+4.828 V	_____	_____	+5.172 V

TDS694C Test Record (cont.)

Instrument Serial Number: _____ Certificate Number: _____
 Temperature: _____ RH %: _____
 Date of Calibration: _____ Technician: _____

TDS694C Performance Test		Minimum	Incoming	Outgoing	Maximum
CH2	200 mV Vert scale setting, 0 Div position setting, -5 V offset	-5.172 V	_____	_____	-4.828 V
CH2	1 V Vert scale setting, 0 Div position setting, +2.5 V offset	+4.738 V	_____	_____	+5.263 V
CH2	1 V Vert scale setting, 0 Div position setting, -2.5 V offset	-5.263 V	_____	_____	-4.738 V
CH3	10 mV Vert scale setting, -5 Div position setting, +.5 V offset	+0.5755 V	_____	_____	+0.5845 V
CH3	10 mV Vert scale setting, +5 Div position setting, -.5 V offset	-0.5845 V	_____	_____	-0.5755 V
CH3	200 mV Vert scale setting, 0 Div position setting, +5 V offset	+4.828 V	_____	_____	+5.172 V
CH3	200 mV Vert scale setting, 0 Div position setting, -5 V offset	-5.172 V	_____	_____	-4.828 V
CH3	1 V Vert scale setting, 0 Div position setting, +2.5 V offset	+4.738 V	_____	_____	+5.263 V
CH3	1 V Vert scale setting, 0 Div position setting, -2.5 V offset	-5.263 V	_____	_____	-4.738 V
CH4	10 mV Vert scale setting, -5 Div position setting, +.5 V offset	+0.5755 V	_____	_____	+0.5845 V
CH4	10 mV Vert scale setting, +5 Div position setting, -.5 V offset	-0.5845 V	_____	_____	-0.5755 V
CH4	200 mV Vert scale setting, 0 Div position setting, +5 V offset	+4.828 V	_____	_____	+5.172 V
CH4	200 mV Vert scale setting, 0 Div position setting, -5 V offset	-5.172 V	_____	_____	-4.828 V
CH4	1 V Vert scale setting, 0 Div position setting, +2.5 V offset	+4.738 V	_____	_____	+5.263 V
CH4	1 V Vert scale setting, 0 Div position setting, -2.5 V offset	-5.263 V	_____	_____	-4.738 V
Analog Bandwidth					
CH1	100 mV	424 mV	_____	_____	N/A
CH2	100 mV	424 mV	_____	_____	N/A
CH3	100 mV	424 mV	_____	_____	N/A
CH4	100 mV	424 mV	_____	_____	N/A
Delay Between Channels		N/A	_____	_____	50 ps

TDS694C Test Record (cont.)

Instrument Serial Number: _____ Certificate Number: _____
 Temperature: _____ RH %: _____
 Date of Calibration: _____ Technician: _____

TDS694C Performance Test	Minimum	Incoming	Outgoing	Maximum
Time Base System				
Long Term Sample Rate/ Delay Time @ 100 ns/10.0 ms	-1.0 Div	_____	_____	+1.0 Div
Trigger System Accuracy				
Pulse-Glitch or Pulse-Width, Hor. scale $\leq 1 \mu\text{s}$				
Lower Limit	3.5 ns	_____	_____	6.5 ns
Upper Limit	3.5 ns	_____	_____	6.5 ns
Pulse-Glitch or Pulse-Width, Hor. scale $> 1 \mu\text{s}$				
Lower Limit	1.9 μs	_____	_____	2.1 μs
Upper Limit	1.9 μs	_____	_____	2.1 μs
CH1 Sensitivity, 50 MHz, Main	Pass/Fail	_____	_____	Pass/Fail
CH1 Sensitivity, 50 MHz, Delayed	Pass/Fail	_____	_____	Pass/Fail
CH1 AUX Trigger Input	Pass/Fail	_____	_____	Pass/Fail
CH1 Sensitivity, full bandwidth, Main	Pass/Fail	_____	_____	Pass/Fail
CH1 Sensitivity, full bandwidth, Delayed	Pass/Fail	_____	_____	Pass/Fail
Output Signal Checks				
MAIN TRIGGER OUTPUT, 50 Ω				
High	High $\geq 1.0 \text{ V}$	_____	_____	
Low		_____	_____	Low $\leq 0.25 \text{ V}$
DELAYED TRIGGER OUTPUT, 50 Ω				
High	High $\geq 1.0 \text{ V}$	_____	_____	
Low		_____	_____	Low $\leq 0.25 \text{ V}$
Probe Compensator Output Signal				
Frequency (CH1 Freq).	950 Hz	_____	_____	1.050 kHz
Voltage (difference)	495 mV	_____	_____	505 mV

TDS794D Test Record

Photocopy this and the next two pages and use them to record the performance test results for your TDS794D.

TDS794D Test Record

Instrument Serial Number: _____ Certificate Number: _____
 Temperature: _____ RH %: _____
 Date of Calibration: _____ Technician: _____

TDS794D Performance Test		Minimum	Incoming	Outgoing	Maximum
Offset Accuracy					
CH1 Offset	+10 mV +101 mV	-2.5 mV -25.1 mV	_____	_____	+2.5 mV +25.1 mV
CH2 Offset	+10 mV +101 mV	-2.5 mV -25.1 mV	_____	_____	+2.5 mV +25.1 mV
CH3 Offset	+10 mV +101 mV	-2.5 mV -25.1 mV	_____	_____	+2.5 mV +25.1 mV
CH4 Offset	+10 mV +101 mV	-2.5 mV -25.1 mV	_____	_____	+2.5 mV +25.1 mV
DC Voltage Measurement Accuracy (Averaged)					
CH1	10 mV Vert scale setting, -5 Div position setting, +.5 V offset	+0.5755 V	_____	_____	+0.5845 V
CH1	10 mV Vert scale setting, +5 Div position setting, -.5 V offset	-0.5845 V	_____	_____	-0.5755 V
CH1	200 mV Vert scale setting, 0 Div position setting, +5 V offset	+4.9405 V	_____	_____	+5.0595 V
CH1	200 mV Vert scale setting, 0 Div position setting, -5 V offset	-5.0595 V	_____	_____	-4.9405 V
CH1	1 V Vert scale setting, 0 Div position setting, +2.5 V offset	+4.794 V	_____	_____	+5.206 V
CH1	1 V Vert scale setting, 0 Div position setting, -2.5 V offset	-5.206 V	_____	_____	-4.794 V
CH2	10 mV Vert scale setting, -5 Div position setting, +.5 V offset	+0.5755 V	_____	_____	+0.5845 V
CH2	10 mV Vert scale setting, +5 Div position setting, -.5 V offset	-0.5845 V	_____	_____	-0.5755 V
CH2	200 mV Vert scale setting, 0 Div position setting, +5 V offset	+4.9405 V	_____	_____	+5.0595 V

TDS794D Test Record (cont.)

Instrument Serial Number: _____ Certificate Number: _____
 Temperature: _____ RH %: _____
 Date of Calibration: _____ Technician: _____

TDS794D Performance Test		Minimum	Incoming	Outgoing	Maximum
CH2	200 mV Vert scale setting, 0 Div position setting, -5 V offset	-5.0595 V	_____	_____	-4.9405 V
CH2	1 V Vert scale setting, 0 Div position setting, +2.5 V offset	+4.794 V	_____	_____	+5.206 V
CH2	1 V Vert scale setting, 0 Div position setting, -2.5 V offset	-5.206 V	_____	_____	-4.794 V
CH3	10 mV Vert scale setting, -5 Div position setting, +.5 V offset	+0.5755 V	_____	_____	+0.5845 V
CH3	10 mV Vert scale setting, +5 Div position setting, -.5 V offset	-0.5845 V	_____	_____	-0.5755 V
CH3	200 mV Vert scale setting, 0 Div position setting, +5 V offset	+4.9405 V	_____	_____	+5.0595 V
CH3	200 mV Vert scale setting, 0 Div position setting, -5 V offset	-5.0595 V	_____	_____	-4.9405 V
CH3	1 V Vert scale setting, 0 Div position setting, +2.5 V offset	+4.794 V	_____	_____	+5.206 V
CH3	1 V Vert scale setting, 0 Div position setting, -2.5 V offset	-5.206 V	_____	_____	-4.794 V
CH4	10 mV Vert scale setting, -5 Div position setting, +.5 V offset	+0.5755 V	_____	_____	+0.5845 V
CH4	10 mV Vert scale setting, +5 Div position setting, -.5 V offset	-0.5845 V	_____	_____	-0.5755 V
CH4	200 mV Vert scale setting, 0 Div position setting, +5 V offset	+4.9405 V	_____	_____	+5.0595 V
CH4	200 mV Vert scale setting, 0 Div position setting, -5 V offset	-5.0595 V	_____	_____	-4.9405 V
CH4	1 V Vert scale setting, 0 Div position setting, +2.5 V offset	+4.794 V	_____	_____	+5.206 V
CH4	1 V Vert scale setting, 0 Div position setting, -2.5 V offset	-5.206 V	_____	_____	-4.794 V
Analog Bandwidth					
CH1	100 mV	424 mV	_____	_____	N/A
CH2	100 mV	424 mV	_____	_____	N/A
CH3	100 mV	424 mV	_____	_____	N/A
CH4	100 mV	424 mV	_____	_____	N/A
Delay Between Channels		N/A	_____	_____	50 ps

TDS794D Test Record (cont.)

Instrument Serial Number: _____ Certificate Number: _____
 Temperature: _____ RH %: _____
 Date of Calibration: _____ Technician: _____

TDS794D Performance Test	Minimum	Incoming	Outgoing	Maximum
Time Base System				
Long Term Sample Rate/ Delay Time @ 100 ns/10.0 ms	-2.5 Div	_____	_____	+2.5 Div
Trigger System Accuracy				
Pulse-Glitch or Pulse-Width, Hor. scale $\leq 1 \mu\text{s}$				
Lower Limit	3.5 ns	_____	_____	6.5 ns
Upper Limit	3.5 ns	_____	_____	6.5 ns
Pulse-Glitch or Pulse-Width, Hor. scale $> 1 \mu\text{s}$				
Lower Limit	1.9 μs	_____	_____	2.1 μs
Upper Limit	1.9 μs	_____	_____	2.1 μs
CH1 Sensitivity, 50 MHz, Main	Pass/Fail	_____	_____	Pass/Fail
CH1 Sensitivity, 50 MHz, Delayed	Pass/Fail	_____	_____	Pass/Fail
CH1 AUX Trigger Input	Pass/Fail	_____	_____	Pass/Fail
CH1 Sensitivity, full bandwidth, Main	Pass/Fail	_____	_____	Pass/Fail
CH1 Sensitivity, full bandwidth, Delayed	Pass/Fail	_____	_____	Pass/Fail
Output Signal Checks				
MAIN TRIGGER OUTPUT, 50 Ω				
High	High $\geq 1.0 \text{ V}$	_____	_____	
Low		_____	_____	Low $\leq 0.25 \text{ V}$
DELAYED TRIGGER OUTPUT, 50 Ω				
High	High $\geq 1.0 \text{ V}$	_____	_____	
Low		_____	_____	Low $\leq 0.25 \text{ V}$
CH 3 SIGNAL OUTPUT, 50 Ω	p-p $\geq 44 \text{ mV}$	_____	_____	p-p $\leq 66 \text{ mV}$
Probe Compensator Output Signal				
Frequency (CH1 Freq).	950 Hz	_____	_____	1.050 kHz
Voltage (difference)	495 mV	_____	_____	505 mV

Signal Acquisition System Checks

These procedures check those characteristics that relate to the signal-acquisition system and are listed as checked under *Warranted Characteristics* in *Specifications*. Refer to Table 1–1 on page 1–18 for test equipment specifications.

Check Offset Accuracy (Zero Setting)

Equipment required	None
Prerequisites	The oscilloscope must meet the prerequisites listed on page 1–17. See <i>Input Channels versus Model</i> on page 1–2.

1. *Preset the instrument controls:*
 - a. *Initialize the oscilloscope:*
 - Press save/recall **SETUP**.
 - Press the main-menu button **Recall Factory Setup**.
 - Press the side-menu button **OK Confirm Factory Init**.
 - Press **CLEAR MENU** to remove the menus from the screen.
 - b. *Modify the default settings:*
 - Press **SHIFT**; then press **ACQUIRE MENU**.
 - On the TDS 600C, press the main-menu button **Mode**; then press the side-menu button **Average 16**.
 - On the TDS 500D, 700D and 714L, press the main-menu button **Mode**; then press the side-menu button **Hi Res**.
 - Press **CURSOR**.
 - Press the main-menu button **Function**; then press the side-menu button **H Bars**.
 - Press **CLEAR MENU**.
 - Be sure to disconnect any input signals from all four channels.
2. *Confirm input channels are within limits for offset accuracy at zero offset:*
Do the following substeps — test CH 1 first, *skipping substep a, since CH 1 is already set up to be checked from step 1.*
 - a. *Select an unchecked channel:* Press **WAVEFORM OFF** to remove the channel just confirmed from the display. Then, press the front-panel button that corresponds to the channel you are to confirm.

- b. *Set the vertical scale:* Set the vertical **SCALE** to one of the settings listed in Table 1–2 that is not yet checked. (Start with the first setting listed).
- Press **VERTICAL MENU**. Press the main-menu button **Fine Scale**.
 - Use the keypad to enter the vertical scale. For the 1 mV setting, press **1**, **SHIFT**, **m**, then **ENTER**. For the 101 mV setting, press **101**, **SHIFT**, **m**, then **ENTER**. For the 1.01 V setting, press **1.01**, then **ENTER**.
 - Press **CLEAR MENU**.

Table 1–2: DC offset accuracy (zero setting)

Vertical scale setting	Vertical position and offset setting ¹	TDS 600C offset accuracy limits	TDS 500D/700D/714L (except TDS 794D) offset accuracy limits
1 mV	0	±2.1 mV	±1.6 mV
101 mV	0	±75.6 mV	±25.1 mV
1.01 V	0	±756 mV	±251 mV
		TDS694C and TDS794D offset accuracy limits	
10 mV	0	±2.5 mV	
101 mV	0	±25.1 mV	

¹ Vertical position is set to 0 divisions and vertical offset to 0 V when the oscilloscope is initialized in step 1.

- c. *Display the test signal:* The waveform position and offset were initialized for all channels in step 1 and are displayed as you select each channel and its vertical scale.
- d. *Measure the test signal:* Align the active cursor over the waveform by rotating the general purpose knob. Ignore the other cursor. See Figure 1–4.
- e. Read the measurement results at the absolute (@:) cursor readout, not the delta (Δ:) readout on screen. That is, read the offset relative to the ground reference. See Figure 1–4.
- f. *Check against limits:* Do the following subparts in the order listed.
- CHECK that the measurement results are within the limits listed for the current vertical scale setting.
 - Enter voltage on test record.

- Repeat substeps b through f until all vertical scale settings listed in Table 1–2, are checked for the channel under test.

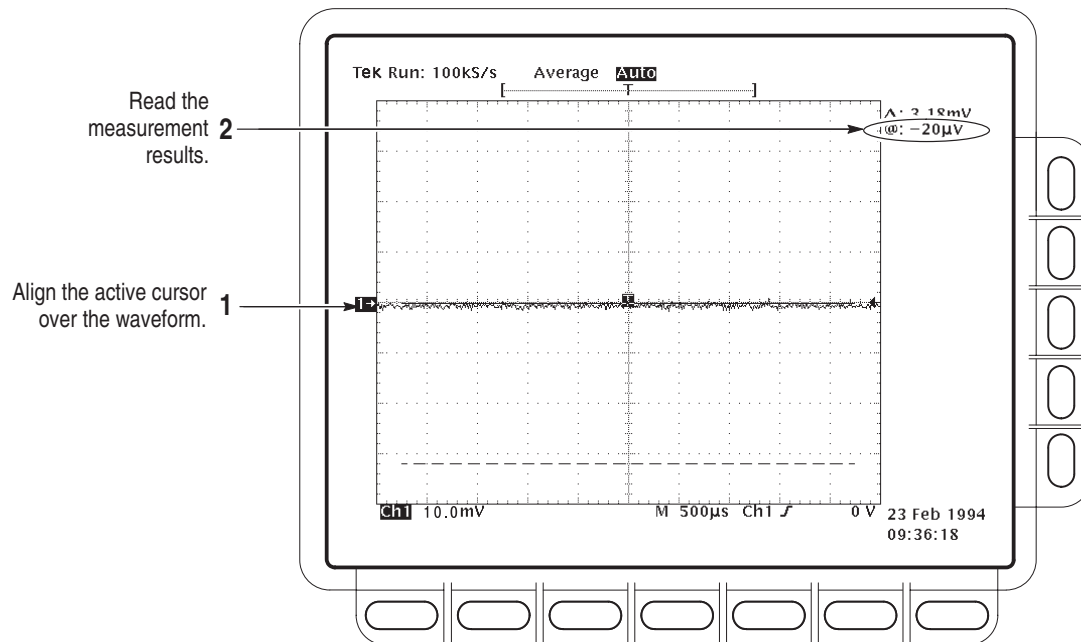

Figure 1–4: Measurement of DC offset accuracy at zero setting – TDS 684C shown

- g. Test all channels:* Repeat substeps a through f for all input channels.

Check DC Voltage Measurement Accuracy



WARNING. The generator is capable of outputting dangerous voltages. Be sure to set the DC calibration generator to off or 0 volts before connecting, disconnecting, and/or moving the test hookup during the performance of this procedure. Also, check that the calibrator does not have shorting straps installed between the DC and sense outputs or grounds.

Equipment required	Two dual-banana connectors (Item 6) One BNC T connector (Item 7) One DC calibration generator (Item 9) Two precision 50 Ω coaxial cables (Item 5)
Prerequisites	The oscilloscope must meet the prerequisites listed on page 1–17 See <i>Input Channels versus Model</i> on page 1–2.

1. Install the test hookup and preset the instrument controls:

a. Hook up the test-signal source:

- Set the output of a DC calibration generator to off or 0 volts.
- Connect the output of a DC calibration generator through a dual-banana connector followed by a 50 Ω precision coaxial cable to one side of a BNC T connector. See Figure 1–5.
- Connect the Sense output of the generator through a second dual-banana connector followed by a 50 Ω precision coaxial cable to the other side of the BNC T connector. Now connect the BNC T connector to **CH 1**. See Figure 1–5.

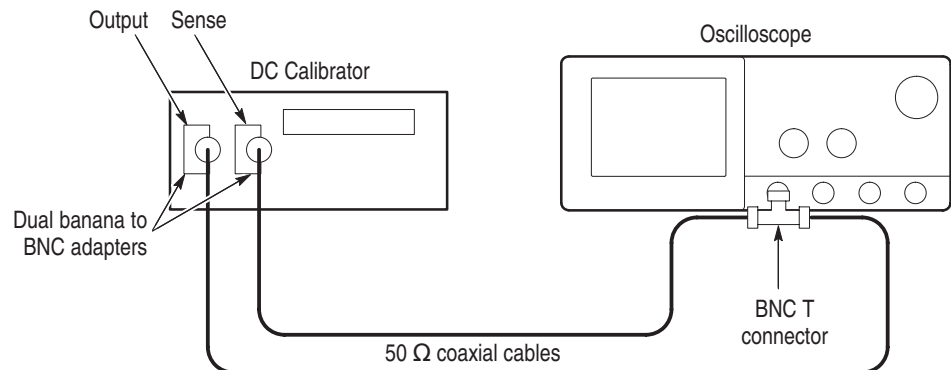

Figure 1–5: Initial test hookup

- b. *Initialize the oscilloscope:*
 - Press save/recall **SETUP**.
 - Press the main-menu button **Recall Factory Setup**.
 - Press the side-menu button **OK Confirm Factory Init**.
 - c. *Modify the default settings:*
 - Press **SHIFT**; then press **ACQUIRE MENU**.
 - Press the main-menu button **Mode**; then press the side-menu button **Average 16**.
2. *Confirm input channels are within limits for DC accuracy at maximum offset and position: Do the following substeps — test CH 1 first, skipping substep 2a since CH 1 is already selected from step 1.*
- a. *Select an unchecked channel:*
 - Press **WAVEFORM OFF** to remove the channel just confirmed from the display.
 - Press the front-panel button that corresponds to the channel you are to confirm.
 - *Set the generator output to 0 V.*
 - Move the test hookup to the channel you selected.
 - b. *Turn on the measurement Mean for the channel:*
 - Press **MEASURE**, then press the main-menu button **Select Measrmt for CHx**.
 - Press the side-menu button **more** until the menu label **Mean** appears in the side menu (its icon is shown at the left). Press the side-menu button **Mean**.
 - Press **CLEAR MENU**.
 - c. *Set the vertical scale:* Set the vertical **SCALE** to one of the settings listed in Table 1–3 that is not yet checked. (Start with the first setting listed).



Table 1–3: DC Voltage measurement accuracy

Scale setting	Position setting (Divs)	Offset setting	Generator setting	TDS 600C (except TDS694C) Accuracy limits	TDS 500D/700D/714L (except TDS794D) Accuracy limits
5 mV	–5	+1 V	+1.040 V	+1.0329 V to +1.0471 V	+1.0355 V to +1.0445 V
	+5	–1 V	–1.040 V	–1.0471 V to –1.0329 V	–1.0445 V to –1.0355 V
200 mV	–5	+10 V	+11.6 V	+11.4165 V to +11.7835 V	+11.5195 V to +11.6805 V
	+5	–10 V	–11.6 V	–11.7835 V to –11.4165 V	–11.6805 V to –11.5195 V
1.01 V	–5	+10 V	+18V	+17.102 V to +18.899 V	+17.621 V to +18.379 V
	+5	–10 V	–18 V	–18.899 V to –17.102 V	–18.379 V to –17.621 V
				TDS694C Accuracy limits	TDS794D Accuracy limits
10 mV	–5	+0.5 V	+0.58 V	+575.5 mV to +584.5 mV	+575.5 mV to +584.5 mV
	+5	–0.5 V	–0.58 V	–584.5 mV to –575.5 mV	–584.5 mV to –575.5 mV
200 mV	0	+5 V	+5.0 V	+4.828 V to +5.172 V	+4.9405 V to +5.0595 V
	0	–5 V	–5.0 V	–5.172 V to –4.828 V	–5.0595 V to –4.9405 V
1 V	0	+2.5 V	+5.0 V	+4.738 V to +5.263 V	+4.794 V to +5.206 V
	0	–2.5 V	–5.0 V	–5.263 V to –4.738 V	–5.206 V to –4.794 V

d. *Display the test signal:*

- Press **VERTICAL MENU**. Press the main-menu button **Position**.
- Use the keypad to set vertical position to –5 divisions (press **–5**, then **ENTER**, on the keypad). The baseline level will move off screen.
- Press the main-menu button **Offset**.
- Use the keypad to set vertical offset to the positive-polarity setting listed in the table for the current vertical scale setting. The baseline level will remain off screen.
- Set the generator to the level and polarity indicated in the table for the vertical scale, position, and offset settings you have made. The DC test level should appear on screen. (If it doesn't return, the DC accuracy check has failed for the current vertical scale setting of the current channel).

e. *Measure the test signal:* Press **CLEAR MENU**. Read the measurement results at the **Mean** measurement readout. See Figure 1–6.

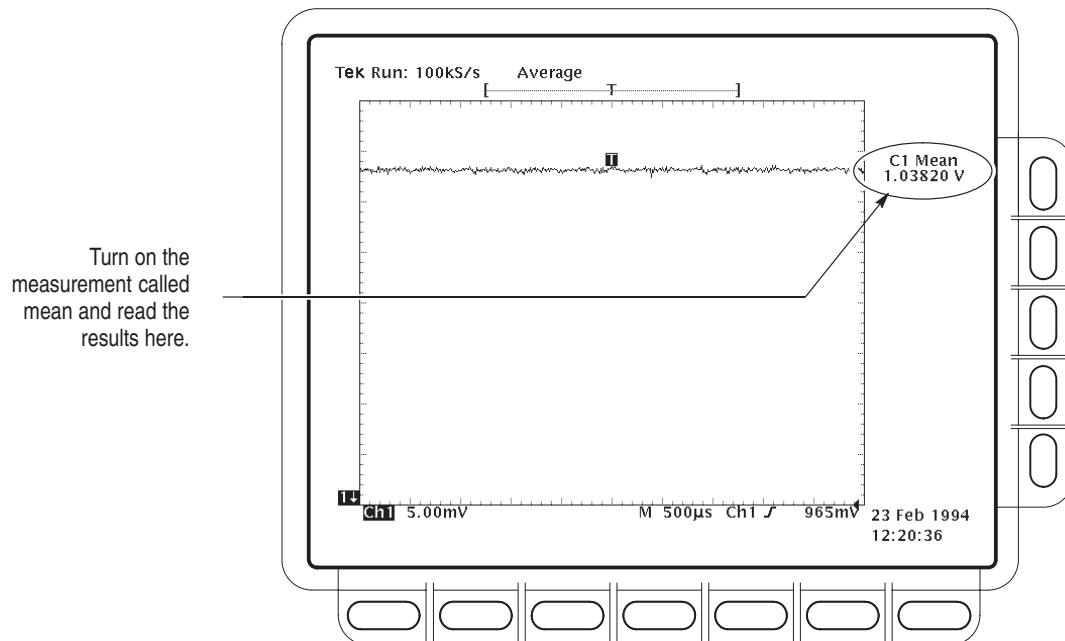

Figure 1–6: Measurement of DC accuracy at maximum offset and position

f. Check against limits:

- CHECK that the readout for the measurement **Mean** readout on screen is within the limits listed for the current vertical scale and position/offset/generator settings. Enter value on test record.
- Repeat substep d, reversing the polarity of the position, offset, and generator settings as is listed in the table.
- CHECK that the **Mean** measurement readout on screen is within the limits listed for the current vertical scale setting and position/offset/generator settings. Enter value on test record.
- Repeat substeps c through f until all vertical scale settings, listed in Table 1–3, are checked for the channel under test.

g. Test all channels: Repeat substeps a through f for all four channels.

3. Disconnect the hookup:

- a.** Set the generator output to 0 V.
- b.** Disconnect the cable from the generator output at the input connector of the channel last tested.

Check Analog Bandwidth

Equipment required	One sine wave generator (Item 14) One level meter and power sensor (Item 15) One power divider (Item 16) One female N to male BNC adapter (Item 18) Four male N to female BNC adapters (Item 17) Two 50 Ω precision cables (Item 5) Attenuators (Items 1 and 2) Optional: One high-frequency leveled sine wave generator and its leveling head – replaces items 14, 15, 16, 17, and 18
Prerequisites	See page 1–17

1. Install the test hookup and preset the instrument controls:**a. Initialize the oscilloscope:**

- Press save/recall **SETUP**. Press the main-menu button **Recall Factory Setup**; then press the side-menu button **OK Confirm Factory Init**.

b. Modify the default settings:

- Turn the horizontal **SCALE** knob to 50 ns (TDS694C 40 ns). Press **SHIFT**; then press **ACQUIRE MENU**.
- Press the main-menu button **Mode**; then press the side-menu button **Average 16**.
- Press **MEASURE**. Press the main-menu button **Level Setup**; then press the side-menu button **Min-Max**.

NOTE. The sine wave generator output amplitude must be leveled to within 0.35 db of the reference frequency (10 MHz) through the bandwidth frequency listed in Table 1–4 on page 1–45. The 0.35 db requirement is necessary to ensure a bandwidth that meets Tektronix specifications.

You can perform bandwidth PV using an unleveled sine wave generator (with amplitude error > 0.35 db). Under these conditions, the bandwidth PV is subject to the flatness errors associated with the generator used.

Refer to the Sine Wave Generator Leveling Procedure on page 1–94 if your sine wave generator does not have automatic output amplitude leveling.

- c. Hook up the test-signal source:** Connect the sine wave output of a leveled sine wave generator to **CH 1**. Set the output of the generator to a

reference frequency of 10 MHz or less. See Figure 1–7.

For the optional setup using a leveled sine wave generator with a leveling head, see Figure 1–8 and, if using this optional setup with the example Tektronix SG 504, set the generator output to 6 MHz.

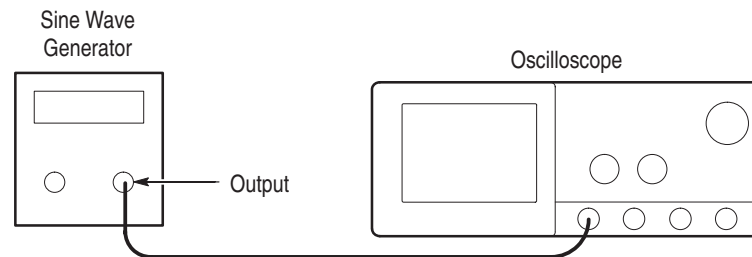

Figure 1–7: Initial test hookup

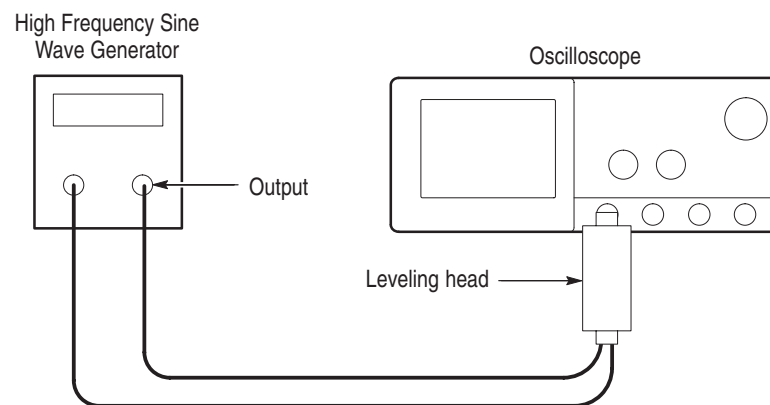

Figure 1–8: Optional initial test hookup

2. *Confirm the input channels are within limits for analog bandwidth:* Do the following substeps — test CH 1 first, *skipping substeps a and b since CH 1 is already set up for testing from step 1.*

a. *Select an unchecked channel:*

- Press **WAVEFORM OFF** to remove the channel just confirmed from display.
- Press the front-panel button that corresponds to the channel you are to confirm.
- Move the leveling output of the sine wave generator to the channel you selected.

- b. *Match the trigger source to the channel selected:*
 - Press **TRIGGER MENU**. Press the main-menu button **Source**; then press the side-menu button that corresponds to the channel selected.
- c. *Set its input impedance: (This substep is not required on the TDS694C and TDS794D.)*
 - Press **VERTICAL MENU**. Press the main-menu button **Coupling**, then press the side-menu **Ω** button to toggle it to the **50 Ω** setting.
- d. *Set the vertical scale: Set the vertical SCALE to one of the settings listed in Table 1–4 not yet checked. (Start with the 100 mV setting).*
- e. *Set the triggering coupling:*
 - Press **TRIGGER MENU**.
 - Press the main-menu button **Coupling**.
 - For vertical settings of 1, 2, and 5 mV, press the side menu button **Noise Rej**. For all other settings, press side menu button **DC**.

Table 1–4: Analog bandwidth

Vertical scale	Reference amplitude (6 divisions)	Horizontal scale	Test frequency					–3 db Limits
			TDS694C	TDS794D	TDS580D TDS680C TDS684C TDS784D	TDS654C	TDS520D TDS540D TDS714L TDS724D TDS754D	
100 mV	600 mV	1 ns	3 GHz	2 GHz	1 GHz	500 MHz	500 MHz	≥424 mV
1 mV	6 mV	1 ns	NA	NA	500 MHz	250 MHz	450 MHz	≥4.24 mV
2 mV	12 mV	1 ns	NA	NA	600 MHz	300 MHz	500 MHz	≥8.48 mV
5 mV	30 mV	1 ns	NA	NA	750 MHz	450 MHz	500 MHz	≥21.2 mV
10 mV	60 mV	1 ns	3 GHz	2 GHz	1 GHz	500 MHz	500 MHz	≥42.4 mV
20 mV	120 mV	1 ns	3 GHz	2 GHz	1 GHz	500 MHz	500 MHz	≥84.8 mV
50 mV	300 mV	1 ns	3 GHz	2 GHz	1 GHz	500 MHz	500 MHz	≥212 mV
200 mV	1.2 V	1 ns	3 GHz	2 GHz	1 GHz	500 MHz	500 MHz	≥848 mV
500 mV	3 V ¹	1 ns	3 GHz	2 GHz	1 GHz	500 MHz	500 MHz	≥2.12 V ¹
1 V	6 V ¹	1 ns	3 GHz	2 GHz	1 GHz	500 MHz	500 MHz	≥4.24 V ¹

¹ If your generator cannot output 6 divisions of amplitude, determine its maximum output at the Test frequency, and use this for the reference amplitude. The –3 db limit can be calculated as: $0.707 \times$ reference amplitude.

f. *Display the test signal:* Do the following subparts to first display the reference signal and then the test signal.



- Press **MEASURE**; then press the main-menu button **Select Measrmt for CHx**.
- Press the side-menu button **more**, if needed, until the menu label **Frequency** appears in the side menu (its icon is shown at the left). Press the side-menu button **Frequency**.
- Press the side-menu button **more** until the menu label **Pk-Pk** appears in the side menu (its icon is shown at the left). Press the side-menu button **Pk-Pk**.
- Press **CLEAR MENU**.
- Set the generator output so the CHx Pk-Pk readout equals the reference amplitude in Table 1–4 that corresponds to the vertical scale set in substep d.
- Press the front-panel button **SET LEVEL TO 50%** as necessary to trigger a stable display. At full bandwidth, you may also want to make small, manual adjustments to the trigger level. You can use the

TRIGGER LEVEL knob to do this. (Full bandwidth varies with TDS model as is shown in Table 1–4).

g. *Measure the test signal:*

- Set the frequency of the generator, as shown on screen, to the test frequency in Table 1–4 that corresponds to the vertical scale set in substep **d**. See Figure 1–9.
- Set the horizontal **SCALE** to the horizontal scale setting in Table 1–4 that corresponds to the vertical scale set in substep **d**. Press **SET LEVEL TO 50%** as necessary to trigger the signal.
- Read the results at the CHx Pk-Pk readout, which will automatically measure the amplitude of the test signal. See Figure 1–9.

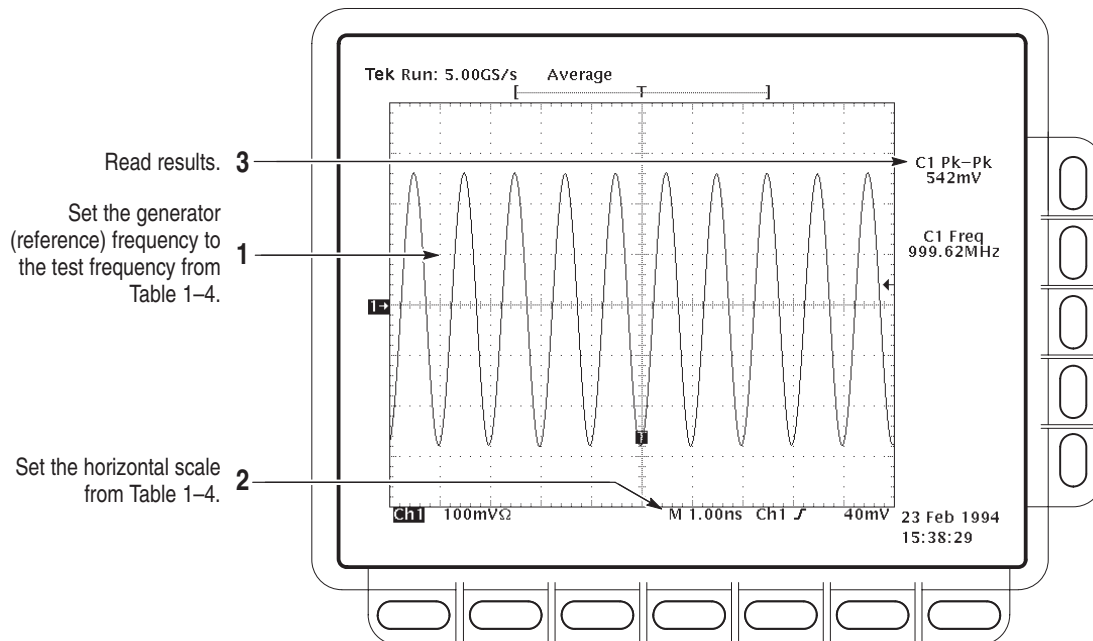

Figure 1–9: Measurement of analog bandwidth

h. *Check against limits:*

- CHECK that the **Pk-Pk** readout on screen is within the limits listed in Table 1–4 for the current vertical scale setting.
- Enter voltage on test record.
- When finished checking, set the horizontal **SCALE** back to the 50 ns (TDS694C 40 ns) setting.

STOP. *Checking each channel's bandwidth at all vertical scale settings is time consuming and unnecessary. You may skip checking the remaining vertical scale settings in Table 1–4 (that is, skip the following substep, i) if this oscilloscope has performed as follows:*

- Passed the 100 mV vertical scale setting just checked in this procedure.
- Passed the *Verify Internal Adjustment, Self Compensation, and Diagnostics* procedure found under *Self Tests*, on page 1–5.

NOTE. *Passing the signal path compensation confirms the signal path for all vertical scale settings for all channels. Passing the internal diagnostics ensures that the factory-set adjustment constants that control the bandwidth for each vertical scale setting have not changed.*

- i. *Check remaining vertical scale settings against limits (optional):*
 - If desired, finish checking the remaining vertical scale settings for the channel under test by repeating substeps d through h for each of the remaining scale settings listed in Table 1–4 for the channel under test.
 - When doing substep f, skip the subparts that turn on the CHx Pk-Pk measurement until you check a new channel.
 - Install/remove attenuators between the generator leveling head and the channel input as needed to obtain the six division reference signals listed in the table.
 - j. *Test all channels:* Repeat substeps a through h for all four channels.
3. *Disconnect the hookup:* Disconnect the test hook up from the input connector of the channel last tested.

Check Delay Between Channels

Equipment required	One sine wave generator (Item 14) Three precision 50 Ω coaxial cables (Item 5) One power divider (Item 16) or dual input coupler (item 8) 3 SMA male to male adapter connector (Item 19) 3 SMA female-to-male BNC adapter connector (Item 20)
Prerequisites	See page 1–17 See <i>Input Channels versus Model</i> on page 1–2.

STOP. *DO NOT use the vertical position knob to reposition any channel while doing this check. To do so invalidates the test.*

1. *Install the test hookup and preset the instrument controls:*
 - a. *Initialize the front panel:*
 - Press save/recall **SETUP**.
 - Press the main-menu button **Recall Factory Setup**.
 - Press the side-menu button **OK Confirm Factory Init**.
 - b. *Modify the initialized front-panel control settings:*
 - Do *not* adjust the vertical position of any channel during this procedure.
 - Set the horizontal **SCALE** to 500 ps.
 - Press **SHIFT**; then press **ACQUIRE MENU**.
 - Press the main-menu button **Mode**, and then press the side-menu button **Average 16**.
 - c. *Hook up the test-signal source:*
 - Connect the sine wave output of a sine wave generator to a 50 Ω precision coaxial cable followed by a 50 Ω termination and a dual-input coupler. (If checking a TDS694C or TDS794C, substitute a 50 Ω power divider and two 50 Ω coaxial cables for the 50 Ω termination and dual-input coupler).
 - Connect the coupler to both **CH 1** and **CH 2**. See Figure 1–10.

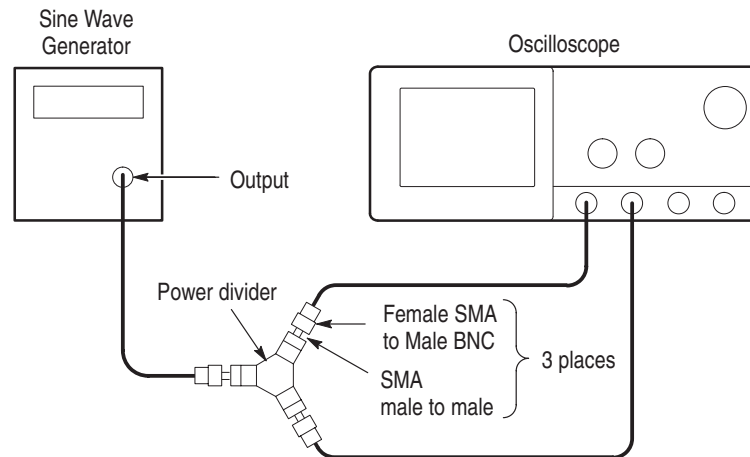

Figure 1–10: Initial test hookup

2. *Confirm all four channels are within limits for channel delay:*

- a. *Set up the generator:* Set the generator frequency to 250 MHz and the amplitude for six to eight divisions in CH 1.

Hint: As you are adjusting the generator amplitude, push **SET LEVEL TO 50%** frequently to speed up the updating of the waveform amplitude on screen.

- b. The horizontal **SCALE** should already be set to 500 ps. On the TDS 580D, 784D, 794D, and all TDS 600C, now set it to 200 ps. On the TDS 520D, 540D, 714L, 724D, and 754D, push the front-panel **ZOOM** button, press the side-menu **On** button, set the horizontal **SCALE** to 250 ps, and be sure the vertical scale factor is kept at 1.0X and the horizontal scale factor is 2.0X for the remainder of this check.
- c. *Save a CH 2 waveform:* Press **CH 2**. Press save/recall **WAVEFORM**. Now, press the main-menu button **Save Wfm**; then press the side-menu button **To Ref 2**.
- d. *Save CH 3 (AX1 on some TDS models) waveform:*
- Move the coupler from **CH 2** to **CH 3** (AUX1 on some TDS models), so that **CH 1** and **CH 3** are driven. Press **WAVEFORM OFF**. Press **CH 3**. Then press the side-menu button **To Ref 3**.
- e. *Display all test signals:*
- Press **WAVEFORM OFF** to remove CH 3 (AX1 on some TDS models) from the display.

- Display the live waveform. Move the coupler from **CH 3** to **CH 4**, so that CH 1 and CH 4 are driven. (Use AUX1 and AUX2 instead of CH3 and CH4 if your TDS model is so equipped). Press **CH 4** to display. See Figure 1–11 on page 1–51.
 - Display the reference waveforms. To do this, press the front-panel button **MORE**. Press the main-menu buttons **Ref 2** and **Ref 3**. You may notice their overlapping ground reference indicators. See Figure 1–11 on page 1–51.
- f.** *Measure the test signal:*
- Locate the time reference points for these waveforms. Do this by first identifying the point where the rising edge of the left-most waveform crosses the center horizontal graticule line. Next, note the corresponding *time reference point* for the right-most waveform. See Figure 1–11 on page 1–51.
 - Press **CURSOR**.
 - Press the main-menu button **Function**; then press the side-menu button **V Bars**.
 - Press **CLEAR MENU**.
 - Align one V bar cursor to the *time reference point* of the left-most waveform edge and the other cursor to the *time reference point* of the right-most waveform edge by rotating the General Purpose knob. (Press **SELECT** to switch between the two cursors). See Figure 1–11 on page 1–51.
 - Read the measurement results at the Δ : cursor readout, not the @: readout on screen.

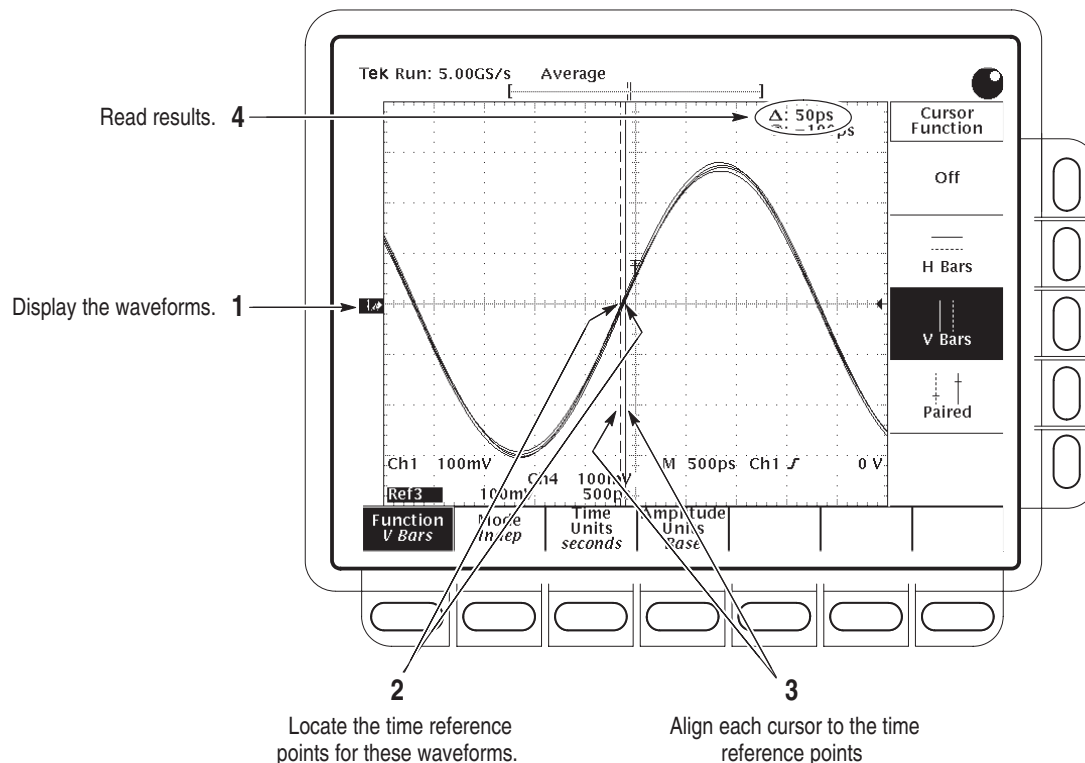

Figure 1-11: Measurement of channel delay – TDS 684C shown

- g. *Check against limits:* CHECK that the cursor readout on screen is ≤ 100 ps for the TDS600C or ≤ 50 ps for the TDS 500D, TDS694C, TDS700D, and TDS714L.
- h. If the channel skew is within the limits, enter time on the test record and proceed to step 3. Otherwise, proceed with steps **i** through **p**.
- i. Use the cursors to measure the skew from CH1 to CH2, CH1 to CH3, and CH1 to CH4 (use AX1 and AX2 instead of CH3 and CH4 if your TDS model is so equipped). Write down these three numbers in the first measurement column of Table 1-5. Note that these numbers may be either positive or negative.
- j. Repeat the procedure from step 1.c through 2.e.
- k. Again use the cursors to measure the skew from CH1 to CH2, CH1 to CH3, and CH1 to CH4. Write down these numbers in the second measurement column of Table 1-5. Note that these numbers may be either positive or negative.
- l. Add the first CH1 to CH2 skew measurement to the second CH1 to CH2 skew measurement and divide the result by 2. Use Table 1-5.

- m. Add the first CH1 to CH3 (AX1 on some TDS models) skew measurement to the second CH1 to CH3 skew measurement and divide the result by 2. Use Table 1–5.
- n. Add the first CH1 to CH4 (AX2 on some TDS models) skew measurement to the second CH1 to CH4 skew measurement and divide the result by 2. Use Table 1–5.
- o. Check against limits: CHECK that the largest of the three results from steps l, m, and n is between –100 ps and + 100 ps for the TDS600C or between –50 ps and + 50 ps for the TDS500D, TDS694C, TDS700D, and TDS714L.
- p. Enter time on the test record.

Table 1–5: Delay between channels worksheet

Coupling	First measurement	Second measurement	Add first and second measurements	Divide sum by 2
CH1 to CH2 skew				
CH1 to CH3 skew				
CH1 to CH4 skew				

- 3. *Disconnect the hookup:* Disconnect the cable from the generator output at the input connectors of the channels.

Time Base System Checks

These procedures check those characteristics that relate to the Main and Delayed time base system and are listed as checked under *Warranted Characteristics in Specifications*.

Check Accuracy for Long-Term Sample Rate and Delay Time

Equipment required	One time-mark generator (Item 11), or Sine wave generator (Item 14) One 50 Ω , precision coaxial cable (Item 5)
Prerequisites	See page 1–17

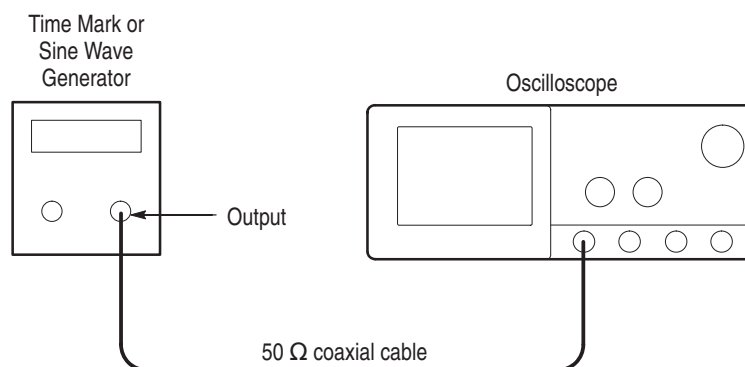

Figure 1–12: Initial test hookup

1. *Install the test hookup and preset the instrument controls:*
 - a. *Hook up the test-signal source:* Connect, through a 50 Ω precision coaxial cable, the output of the generator to **CH 1** (see Figure 1–12).
 - If using a time-mark generator, set the output for 10 ms markers.
 - If using a sine wave generator, set the output for 1.2 V and 500 kHz.
 - b. *Initialize the oscilloscope:*
 - Press save/recall **SETUP**. Press the main-menu button **Recall Factory Setup**. Press the side-menu button **OK Confirm Factory Init**.
 - c. *Modify the initialized front-panel control settings:*
 - Set the vertical **SCALE** to 200 mV (or 500 mV with the optional Tektronix TG 501A Time Mark Generator).
 - Set the horizontal **SCALE** of the Main time base to 2 μ s.

- Press **VERTICAL MENU**; then press the main-menu button **Coupling**. Press the side-menu button **Ω** to toggle it to the **50 Ω** setting. (This step is not required on the TDS694C or TDS794D.)
 - Press **SET LEVEL TO 50%**.
 - Use the vertical **POSITION** knob to center the test signal on screen.
 - Press **TRIGGER MENU**; then press the main-menu button **Mode & Holdoff**. Press the side-menu button **Normal**.
2. *Confirm Main and Delayed time bases are within limits for accuracies:*
- a. *Display the test signal:*
 - Press **HORIZONTAL MENU**.
 - Set horizontal modes. To do this, press the main-menu button **Time Base**. Press the side-menu buttons **Delayed Only** and **Delayed Runs After Main**. See Figure 1–13 on page 1–55.
 - b. *Measure the test signal:*
 - Set the horizontal **SCALE** of the **D** (delayed) time base to 500 ns for the TDS600C or to 100 ns for the TDS694C, TDS500D, TDS700D, or TDS714L.
 - If using a time-mark generator, align the trigger **T** to the center vertical graticule line by adjusting the horizontal **POSITION**. See Figure 1–13 on page 1–55.
 - If using a sine wave generator, align the rising edge of the sine wave on the center graticule crosshairs by adjusting the horizontal **POSITION**.
 - Set delayed time to 10.000016 ms. Do this on the keypad by pressing **10.000016**, then **SHIFT**, then **m** followed by **ENTER**).
 - c. *Check long-term sample rate and delay time accuracies against limits:*
 - **CHECK** that the rising edge of the marker (or sine wave) crosses the center horizontal graticule line at a point within either ± 1.0 divisions for the TDS694C, ± 2.0 divisions for the TDS600C, ± 2.5 divisions for the TDS500D, TDS700D, or TDS714L, of center graticule.
See Figure 1–13 on page 1–55.
 - Enter number of divisions on the test record.

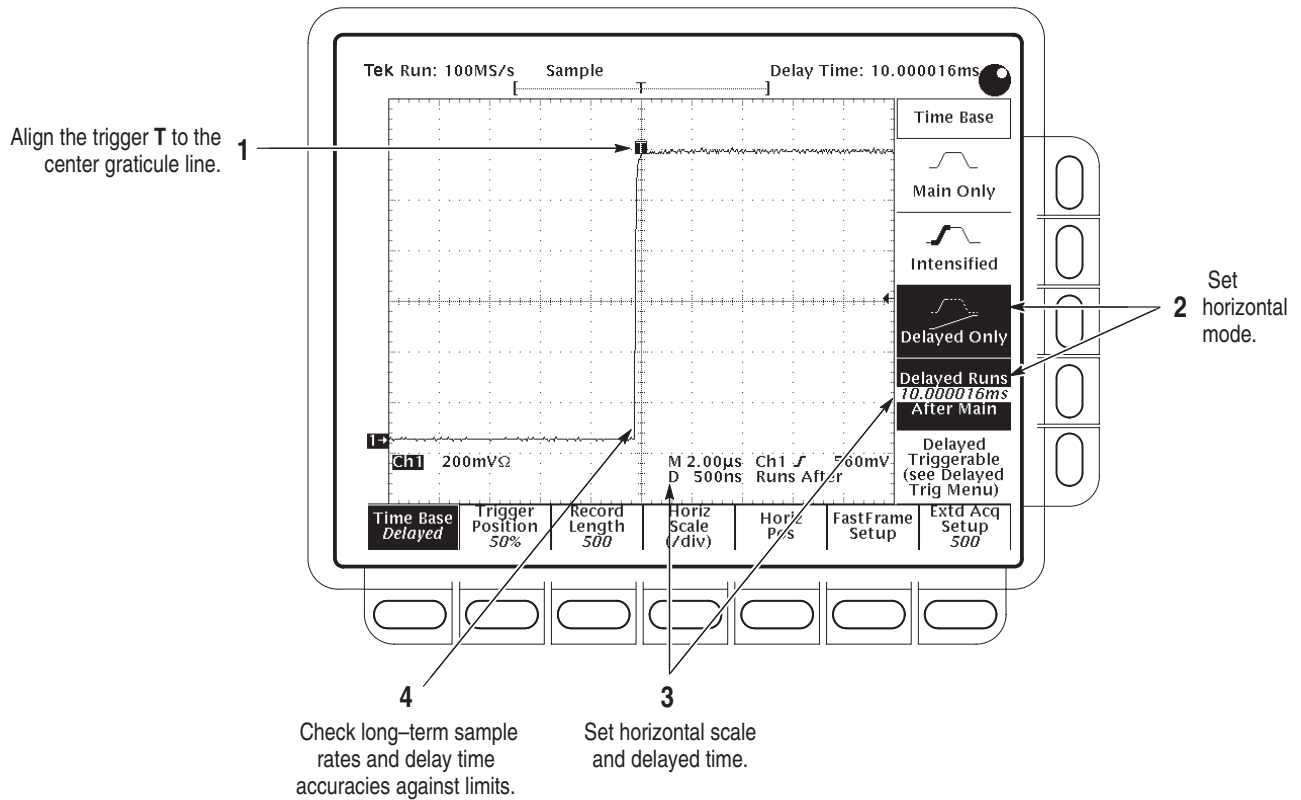

Figure 1-13: Measurement of accuracy – long-term and delay time

3. *Disconnect the hookup:* Disconnect the cable from the generator output at the input connector of CH 1.

Check Accuracy for Delta Time Measurement (Skip for Option 1G and TDS 714L)

Equipment required	One 50 Ω, precision coaxial cable (Item 5) One Connector, BNC “T”, male BNC-to-dual female BNC (Item 7) One Pulse Generator, Wavetek 9500 or equivalent (Item 23) Two 50 Ω, coaxial cable, male-to-male SMA connectors (Item 28) One SMA female to BNC male connector (Item 30) One BNC elbow connector (Item 31) One SMA “T”, male to two SMA female connectors (Item 29) Two SMA terminator connectors, short circuit, (Item 32) One 2X attenuator, 50 Ω, female BNC-to- male BNC (Item 33)
Prerequisites	See page 1-17

This procedure checks the “sample rate” portion of the Delta Time Measurement Accuracy as listed under *Warranted Characteristics* in *Specifications*. The previous procedure, *Check Accuracy for Long-Term Sample Rate and Delay Time*, see page 1-53, verified the “PPM” portion of the delta time specification.

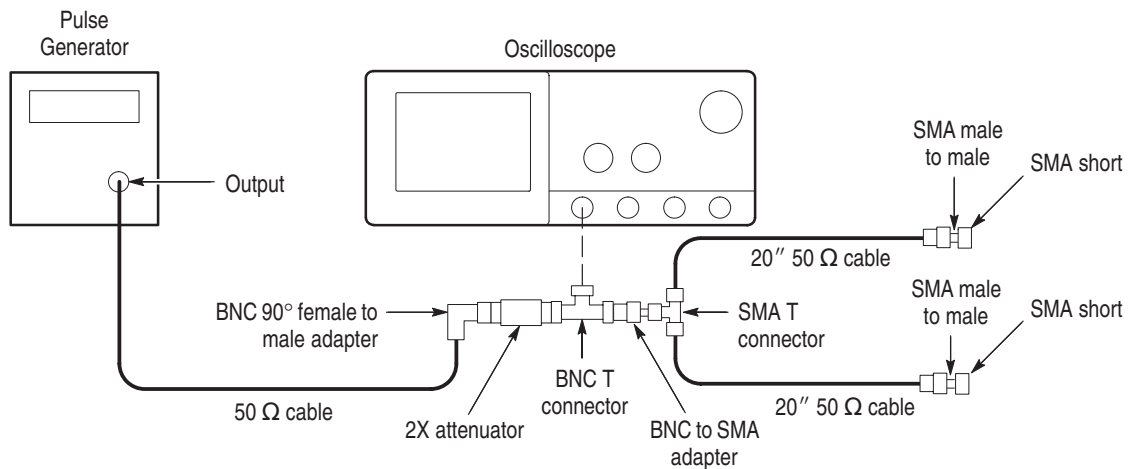

Figure 1-14: Delta time accuracy test hookup

1. *Install the test hookup and preset the instrument controls:*
 - a. *Initialize the oscilloscope:*
 - Press save/recall **SETUP**. Press the main-menu button **Recall Factory Setup**. Press the side-menu button **OK Confirm Factory Init**.

- b. *Hook up the pulse generator (see Figure 1–14 on page 1–56):*
- Connect the pulse generator output to a **50 Ω** precision coaxial cable followed by a 90° right-angle female to male BNC adapter, then a **50 Ω 2X** attenuator. The attenuator is connected to one side of the female BNC T connector. The other side of the BNC T is connected to BNC male to SMA adapter. The SMA side is connected to male side of the SMA T connector. (Keep the distance between the BNC T and SMA T as short as possible). Connect 20 inch **50 Ω** coaxial cables to each female side of the SMA T connector. Connect a female to female SMA adapter to both male coaxial connectors. Connect the SMA short, to the remaining female SMA adapter. Now connect the male BNC T connector to **CH 1**.
 - Set the pulse generator output for a positive-going pulse with a rise–time as shown in Table 1–6 on page 1–58 for your oscilloscope, and for the fastest possible rep rate (at least 1 kHz).
 - Set the pulse generator output for about 500 mV. (This amplitude can be adjusted later to get a 5–division pulse on screen.)
- c. *Modify the initialized front-panel control settings:*
- *(This substep is not required on the TDS694C or TDS794D.)* Press **VERTICAL MENU**. Press the main-menu button **Coupling**, then press the side-menu **Ω** button to toggle it to the **50 Ω** setting.
 - Press **AUTOSET**. You may see both positive and negative pulses. Adjust the trigger **MAIN LEVEL** knob so the trigger level is about 50% of the rising edge of the **positive** pulse.
 - *(TDS 500D/700D/714L only.)* Press **SHIFT**; then press **ACQUIRE MENU**. Press the main-menu button **Repetitive Signal**, then press the side-menu **OFF (Real Time Only)**.
 - Set the horizontal **SCALE** of the Main time base to 2 ns/division. The pulse width should be about **6 ns**.
 - Adjust pulse amplitude and oscilloscope vertical scale and position as necessary to obtain about **5 divisions** of the **positive** pulse.
- d. *Set up for statistics measurements:*
- Re-adjust the trigger **MAIN LEVEL** knob so the trigger level is about 50% of the rising edge of the **positive** pulse.
 - Press **RUN/STOP** button to freeze the display.
 - Press **MEASURE** to bring up the Measure menu.

- Press **MEASURE** → **Select Measurmnt for Ch1** (main menu) → **Positive Width** (side menu).
- Press **Statistics** → **Statistics OFF** (side menu) to reset the statistics, then press → **Statistics Mean/StdDev** (side menu).
- Press **Statistics Weights** (side menu). On the keypad press **1000**, then **ENTER**.
- Press **RUN/STOP** button to start the acquisitions.
- Wait about 30 seconds.
- Press **RUN/STOP** button to freeze the display.
- Record the mean, μ (value).
- Press **Statistics Min/Max** (side menu) to display those values.
- Calculate the difference of the Max minus the mean.
- Calculate the difference of the mean minus the Min.
- Both differences must be less than or equal to the Delta-time accuracy limit shown in Table 1–6 for your oscilloscope.

Table 1–6: Delta time measurement

Oscilloscope type	Pulse rise time range	Delta time accuracy limit
TDS520D, TDS540D, TDS724D, TDS754D	≤ 2 ns	≤ 0.075 ns
TDS580D, TDS784D	≤ 900 ps	≤ 0.038 ns
TDS794D	300 ps – 1 ns	≤ 0.038 ns
TDS654C	≤ 150 ps	≤ 0.040 ns
TDS680C, TDS684C	≤ 700 ps	≤ 0.040 ns
TDS694C	50 ps – 400 ps	≤ 0.015 ns

e. *Repeat for all other channels:*

- Note the vertical scale setting of the channel just confirmed.
- Press **WAVEFORM OFF** to remove the channel just confirmed from display.
- Press the front-panel button that corresponds to the channel you are to confirm.
- Set vertical **SCALE** to the setting noted in step e, first bullet.

- Press **TRIGGER MENU**. Press the main-menu button **Source**; then press the side-menu button that corresponds to the channel selected.
 - Move the test hookup to the channel you selected.
 - *(This substep is not required on the TDS694C or TDS794D.)* Press **VERTICAL MENU**. Press the main-menu button **Coupling**, then press the side-menu **Ω** button to toggle it to the **50 Ω** setting.
 - Press **RUN/STOP** button to start the display.
 - Repeat step **d**.
2. *Disconnect all test equipment from the oscilloscope:*

Trigger System Checks

These procedures check those characteristics that relate to the Main and Delayed trigger systems and are listed as checked in *Specifications*.

Check Accuracy (Time) for Pulse-Glitch or Pulse-Width Triggering

Equipment required	One sine wave generator (Item 14) One 10X attenuator (Item 1) One 50 Ω, precision coaxial cable (Item 5)
Prerequisites	See page 1–17

1. *Install the test hookup and preset the instrument controls:*
 - a. *Initialize the instrument:*
 - Press save/recall **SETUP**.
 - Press the main-menu button **Recall Factory Setup**.
 - Press the side-menu button **OK Confirm Factory Init**.
 - b. *Modify the default setup:*
 - Set the horizontal **SCALE** to 10 ns on the TDS 600C and 12.5 ns on the TDS 500D/700D/714L.
 - Press **VERTICAL MENU**; then press the main-menu button **Coupling**. Now press the side-menu button **Ω** to toggle it to the 50 Ω setting. (This step is not required on the TDS694C or TDS794D.)
 - c. *Hook up the test-signal source:* Connect the output of the sine wave generator (Item 14) to CH 1.

Do this through a 50 Ω precision coaxial cable, followed by a 10X attenuator. See Figure 1–15. The 10X attenuator is optional if the SG503 is used.

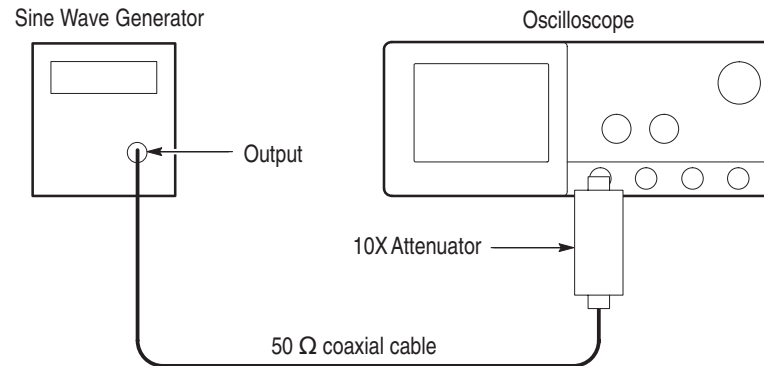

Figure 1–15: Initial test hookup

2. *Confirm the trigger system is within time-accuracy limits for pulse-glitch or pulse-width triggering (time range ≤ 500 ns):*
 - a. *Display the test signal:* Set the output of the sine wave generator for a 100 MHz, five-division sine wave on screen. Press **SET LEVEL TO 50%**.
 - b. *Set the trigger mode:* Press **TRIGGER MENU**. Now press the main-menu button **Mode & Holdoff**; then press the side-menu button **Normal**.
 - c. *Set upper and lower limits that ensure triggering:* See Figure 1–16.
 - Press the main-menu button **Type**; then repeatedly press the same button until **Pulse** is highlighted in the menu that pops up.
 - Press the main-menu button **Class**; then repeatedly press the same button until **Width** is highlighted in the menu that pops up.
 - Press the main-menu button **Trig When**; then press the side-menu button **Within Limits**.
 - Press the side-menu button **Upper Limit**. Use the keyboard to set the upper limit to 10 ns: press **10**, then **SHIFT**, then **n**, and **ENTER**.
 - Press the side-menu button **Lower Limit**. Use the keypad to set the lower limit to 2 ns.
 - d. *Change limits until triggering stops:*

- Press **SET LEVEL TO 50%**.
- While doing the following subparts, monitor the display (it will stop acquiring) and the front-panel light **TRIG** (it will extinguish) to determine when triggering is lost.
- Press the side-menu button **Lower Limit**.
- Use the general purpose knob to *increase* the **Lower Limit** readout until triggering is lost.
- CHECK that the **Lower Limit** readout, after the oscilloscope loses triggering, is within 3.5 ns to 6.5 ns, inclusive.
- Enter time on test record.
- Use the keypad to return the **Lower Limit** to 2 ns and reestablish triggering.
- Press the side-menu button **Upper Limit**; then use the general purpose knob to slowly *decrease* the **Upper Limit** readout until triggering is lost.
- CHECK that the **Upper Limit** readout, after the oscilloscope loses triggering, is within 3.5 ns to 6.5 ns, inclusive.
- Enter time on test record.

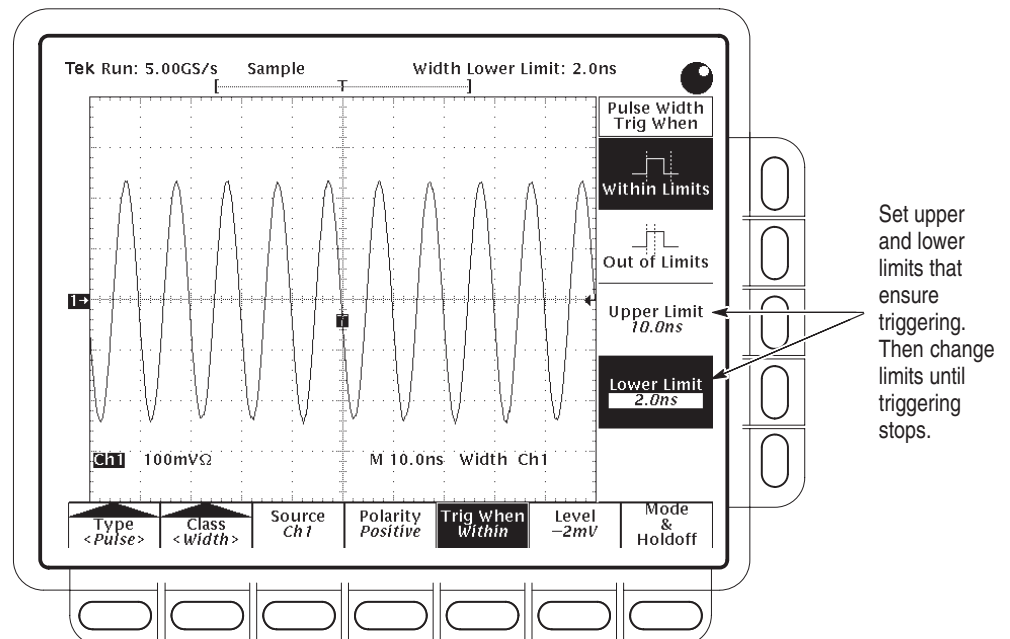

Figure 1-16: Measurement of time accuracy for pulse and glitch triggering

3. *Confirm the trigger system is within time-accuracy limits for pulse-glitch or pulse-width triggering (time range >520 ns):*
 - a. *Set upper and lower limits that ensure triggering at 250 kHz:*
 - Press the side-menu button **Upper Limit**. Use the keyboard to set the upper limit to 4 μ s.
 - Press the side-menu button **Lower Limit**. Use the keypad to set the lower limit to 500 ns.
 - b. *Display the test signal:*
 - Set the horizontal **SCALE** to 5 μ s.
 - Set the output of the sine wave generator for a 250 kHz, five-division sine wave on screen. Set the vertical **SCALE** to 20 mV (the waveform will overdrive the display).
 - Press **SET LEVEL TO 50%**.
 - c. *Check against limits: Do the following subparts in the order listed.*
 - Press the side-menu button **Lower Limit**.
 - Use the general purpose knob to *increase* **Lower Limit** readout until triggering is lost.
 - CHECK that the **Lower Limit** readout, after the oscilloscope stops triggering, is within 1.9 μ s to 2.1 μ s, inclusive.
 - Enter time on test record.
 - Use the keypad to return the **Lower Limit** to 500 ns and reestablish triggering.
 - Press the side-menu button **Upper Limit**; then use the general purpose knob to slowly *decrease* the **Upper Limit** readout until triggering stops.
 - CHECK that the **Upper Limit** readout, after the oscilloscope loses triggering, is within 1.9 μ s to 2.1 μ s, inclusive.
 - Enter time on test record.
4. *Disconnect the hookup: Disconnect the cable from the generator output at the input connector of **CH 1**.*

**Sensitivity, Edge Trigger,
DC Coupled**

Equipment required	One sine wave generator (Item 14) Two precision 50 Ω coaxial cables (Item 5) One 10X attenuator (Item 1) One BNC T connector (Item 7) One 5X attenuator (Item 2)
Prerequisites	See page 1–17.

1. Install the test hookup and preset the instrument controls:**a. Initialize the oscilloscope:**

- Press save/recall **SETUP**.
- Press the main-menu button **Recall Factory Setup**.
- Press the side-menu button **OK Confirm Factory Init**.

b. Modify the initialized front-panel control settings:

- Set the horizontal **SCALE** for the **M** (main) time base to 20 ns on the TDS 600C or 25 ns on the TDS 500D/700D/714L.
- Press **HORIZONTAL MENU**; then press the main-menu button **Time Base**.
- Press the side-menu button **Delayed Only**; then press the side-menu button **Delayed Triggerable**.
- Set the horizontal **SCALE** for the **D** (delayed) time base to 20 ns on the TDS 600C or 25 ns on the TDS 500D/700D/714L; then press the side-menu button **Main Only**.
- Press **TRIGGER MENU**; then press the main-menu button **Mode & Holdoff**. Press the side-menu button **Normal**.
- Press **VERTICAL MENU**; then press the main-menu button **Coupling**. Press the side-menu button Ω to select the 50 Ω setting. (This step is not required on the TDS694C TDS794D.)
- Press **SHIFT**; then press **ACQUIRE MENU**. Press the main-menu button **Mode**; then press the side-menu button **Average 16**.

c. Hook up the test-signal source:

- Connect the signal output of the generator to a BNC T connector. Connect one output of the T connector to **CH 1** through a 50 Ω precision coaxial cable. Connect the other output of the T connector to the **AUX TRIG INPUT** at the rear panel. See Figure 1–17.

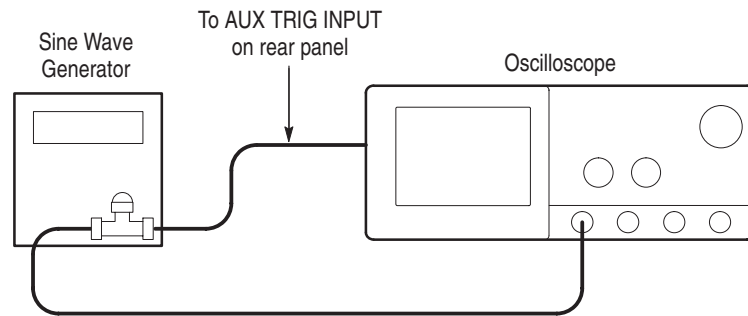

Figure 1–17: Initial test hookup

2. Confirm Main and Delayed trigger systems are within sensitivity limits (50 MHz):

a. Display the test signal:

- Set the generator frequency to 50 MHz.
- Press **MEASURE**.
- Press the main-menu button **Level Setup**; then press the side-menu button **Min-Max**.
- Press the main-menu button **Select Measrmt for Ch1**.
- Press the side-menu button **–more–** until **Amplitude** appears in the side menu (its icon is shown at the left). Press the side-menu button **Amplitude**.
- Press **SET LEVEL TO 50%**.
- Press **CLEAR MENU**.
- Set the test signal amplitude for about three and a half divisions on screen. Now fine adjust the generator output until the **CH 1 Amplitude** readout indicates the amplitude is 350 mV. Readout may fluctuate around 350 mV.
- Disconnect the 50 Ω precision coaxial cable at **CH 1** and reconnect it to **CH 1** through a 10X attenuator.



b. Check the Main trigger system for stable triggering at limits:

- Read the following definition: A stable trigger is one that is consistent; that is, one that results in a uniform, regular display triggered on the selected slope (positive or negative). This display should *not* have its trigger point switching between opposite slopes, nor should it roll across the screen. At horizontal scale settings of

2 ms/division and faster, **TRIG'D** will remain constantly lighted. It will flash for slower settings.

- Press **TRIGGER MENU**; then press the main-menu button **Slope**.
- Adjust the **TRIGGER LEVEL** knob so that there is a stable trigger. CHECK that the trigger is stable for the test waveform on the positive slope.
- Use the side menu to select the negative slope. Adjust the **TRIGGER LEVEL** knob so that there is a stable trigger. CHECK that the trigger is stable for the test waveform on the negative slope.
- Enter pass/fail result for main trigger on the test record.
- Leave the Main trigger system triggered on the positive slope of the waveform before continuing to the next step.

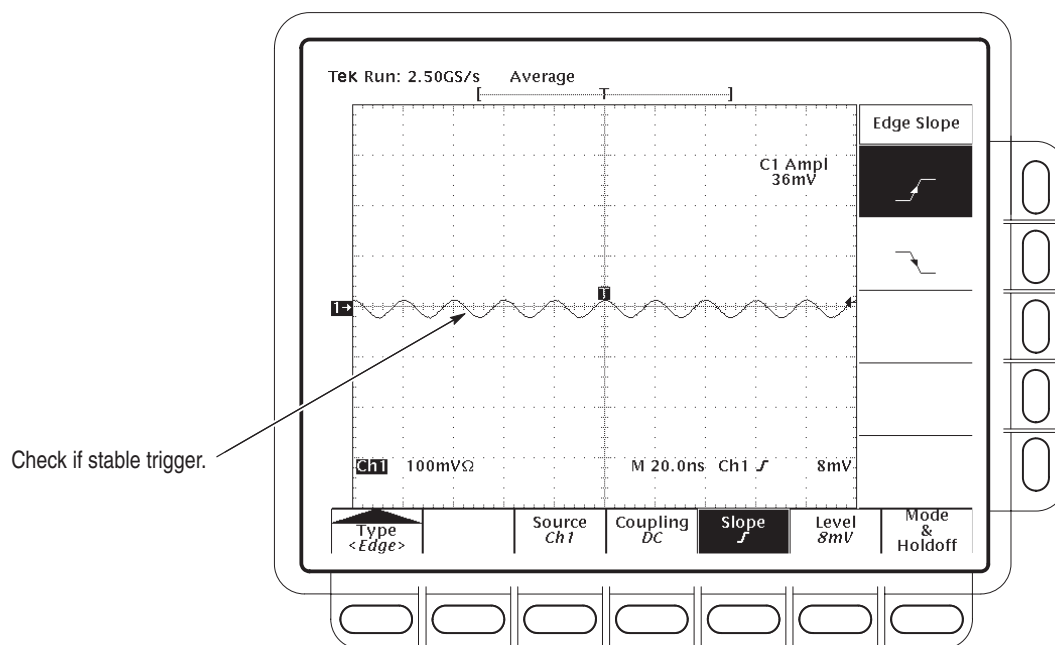

Figure 1-18: Measurement of trigger sensitivity – 50 MHz results shown on a TDS 684C screen

- c. Check Delayed trigger system for stable triggering at limits: Do the following subparts in the order listed.
 - Press **HORIZONTAL MENU**; then press the main-menu button **Time Base**. Press the side-menu button **Delayed Only**; then press **Delayed Triggerable** in the same menu.

- Press **SHIFT**; then press **DELAYED TRIG**. Press the main-menu button **Level**.
- Press the side-menu button **SET TO 50%**.

CHECK that a stable trigger is obtained for the test waveform for both the positive and negative slopes of the waveform. Use the **TRIGGER LEVEL** knob to stabilize the Main trigger. Use the general purpose knob to stabilize the Delayed trigger. Press the main-menu button **Slope**; then use the side menu to switch between trigger slopes. See Figure 1–18 on page 1–65.

- Enter pass/fail result for delayed trigger on the test record.
- Leave the Delayed trigger system triggered on the positive slope of the waveform before continuing to the next step. Also, return to the main time base: Press **HORIZONTAL MENU**; then press the main-menu button **Time Base**. Press the side-menu button **Main Only**.
- Press **CLEAR MENU**.

3. *Confirm the AUX Trigger input:*

a. *Display the test signal:*

- Remove the 10X attenuator and reconnect the cable to **CH 1**.
- Set the test signal amplitude for about 2.5 divisions on screen.
- Now fine adjust the generator output until the **CH 1 Amplitude** readout indicates the amplitude is 250 mV. (Readout may fluctuate around 250 mV).

b. *Check the AUX trigger source for stable triggering at limits: Do the following in the order listed.*

- Use the definition for stable trigger from step 2.
- Press **TRIGGER MENU**; then press the main-menu button **Source**.
- Press the side-menu button **–more–** until the side-menu label **DC Aux** appears; then press **DC Aux**.
- Press **SET LEVEL TO 50%**. CHECK that a stable trigger is obtained for the test waveform on both the positive and negative slopes. Press the main-menu button **Slope**; then use the side menu to switch between trigger slopes. Use the **TRIGGER LEVEL** knob to stabilize the trigger if required.
- Enter the pass/fail result on the test record.

- Leave the Main trigger system triggered on the positive slope of the waveform before proceeding to the next check.
 - Press the main-menu button **Source**; then press the side-menu button **–more–** until **CH 1** appears. Press **CH 1**.
4. *Confirm that the Main and Delayed trigger systems are within sensitivity limits (full bandwidth):*
- a. *Hook up the test-signal source:* Disconnect the hookup installed in step 1. Connect the signal output of a high-frequency sine wave generator to **CH 1**. Some TDS models need a high frequency (>500 MHz) generator; see footnotes 1 and 5 in Table 1–1 on page 1–18.
 - b. *Set the Main and Delayed Horizontal Scales:*
 - Set the horizontal **SCALE** to 500 ps for the **M** (Main) time base.
 - Press **HORIZONTAL MENU**. Now press the main-menu button **Time base**; then press the side-menu button **Delayed Triggerable**.
 - Press the side-menu button **Delayed Only**.
 - Set the horizontal **SCALE** to 500 ps for the **D** (Delayed) time base. Press the side-menu button **Main Only**.
 - c. *Display the test signal:*
 - Set the generator frequency to full bandwidth as follows:

TDS694C:	3 GHz
TDS794D:	2 GHz
TDS580D, TDS680C, TDS684C, & TDS784D:	1 GHz
TDS520D, TDS540D, TDS654C, TDS714L, TDS724D, & TDS754D:	500 MHz
 - Set the test signal amplitude for about five divisions on screen. Now fine adjust the generator output until the **CH 1 Amplitude** readout indicates the amplitude is 500 mV. (Readout may fluctuate around 500 mV). TDS694C only: Press the set level to 50% and check that a stable trigger is obtained.
 - Disconnect the leveling head at **CH 1** and reconnect it to **CH 1** through a 5X attenuator. Check that a stable trigger is obtained.
 - d. Repeat step 2, substeps **b** and **c** only, for the full bandwidth selected. TDS694C or TDS794D exception: Perform step 2, substep **c** (Delayed trigger) with the generator frequency set to **1.5 GHz**.

NOTE. You just checked the trigger sensitivity. If desired, you may repeat steps 1 through 4 for the other channels (CH2, CH3, and CH4).

5. *Disconnect the hookup:* Disconnect the cable from the channel last tested.

Output Signal Checks

The procedure that follows checks those characteristics of the output signals that are listed as checked under *Warranted Characteristics* in *Specifications*. The oscilloscope outputs these signals at its front and rear panels.

Check Outputs — CH 3 (AUX 1 on some models) Main and Delayed Trigger

Equipment required	Two precision 50 Ω coaxial cables (Item 5) One calibration generator (Item 10)
Prerequisites	See page 1–17. Also, the oscilloscope must have passed <i>Check DC Voltage Measurement Accuracy</i> on page 1–38. See <i>Input Channels versus Model</i> on page 1–2.

1. *Install the test hookup and preset the instrument controls:*

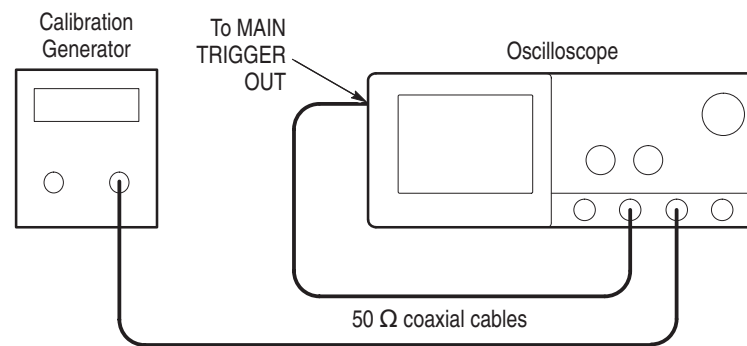

Figure 1–19: Initial test hookup

- a. *Hook up test-signal source 1 (See Figure 1–19):*
 - Connect the standard amplitude output of a calibration generator through a 50 Ω precision coaxial cable to **CH 3 (AUX1)** on some TDS models).
 - Set the output of the calibration generator to 0.500 V.
- b. *Hook up test-signal source 2:* Connect the **Main Trigger Out** at the rear panel to **CH 2** through a 50 Ω precision cable.

- c. *Initialize the oscilloscope:*
- Press save/recall **SETUP**.
 - Press the main-menu button **Recall Factory Setup**.
 - Press the side-menu button **OK Confirm Factory Init**.
- d. *Modify the initialized front-panel control settings:*
- Press **WAVEFORM OFF** to turn off CH 1.
 - Press **CH 3 (AUX 1)** on some TDS models) to display that channel.
 - TDS694C only: Press trigger menu, select Ch 3 as trigger, set to 50%.
 - If necessary, adjust the calibration generator output for 5 divisions of amplitude. (With the 50Ω input of the TDS694C and TDS794D, you may need to double the output of the generator to get 5 divisions of amplitude.)
 - Set the horizontal **SCALE** to 200 μs.
 - Press **SHIFT**; then press **ACQUIRE MENU**.
 - Press the main-menu button **Mode**; then press the side-menu button **Average**.
 - Select **64** averages. Do this with the keypad or the general purpose knob.
2. *Confirm Main and Delayed Trigger outputs are within limits for logic levels:*
- a. *Display the test signal:*
- Press **WAVEFORM OFF** to turn off CH 3.
 - Press **CH 2** to display that channel.
 - Set the vertical **SCALE** to 1 V, 500 mV for TDS694C or TDS794D.
 - Use the vertical **POSITION** knob to center the display on screen.
- b. *Measure logic levels:*
- Press **MEASURE**; then press the main-menu button **Select Measurement for Ch2**.
 - Select high and low measurements. To do this, repeatedly press the side-menu button **–more–** until **High** and **Low** appear in the side menu (their icons are shown at the left). Press both side-menu buttons **High** and **Low**.



- c. *Check Main Trigger output against limits: (Skip the first three subparts of this substep for the TDS694C and TDS794D only.)*
- CHECK that the **Ch2 High** readout is ≥ 2.5 volts and that the **Ch2 Low** readout is ≤ 0.7 volts. See Figure 1–20.
 - Enter high and low voltages on test record.
 - Press **VERTICAL MENU**; then press the main-menu button **Coupling**. Now press the side-menu button Ω to toggle it to the 50Ω setting.
 - CHECK that the **Ch2 High** readout is ≥ 1.0 volt and that the **Ch2 Low** readout ≤ 0.25 volts.
 - Enter high and low voltages on the test record.

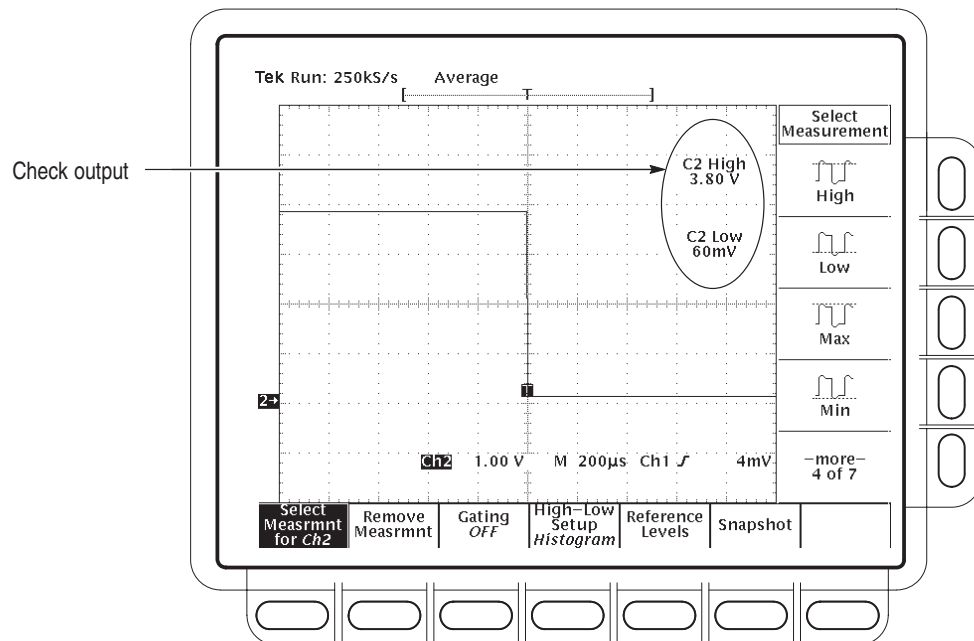

Figure 1–20: Measurement of main trigger out limits

- d. *Check Delayed Trigger output against limits: See Figure 1–20.*
- Move the precision 50Ω cable from the rear-panel **Main Trigger Output** BNC to the rear-panel **Delayed Trigger Output** BNC.
 - CHECK that the **Ch2 High** readout is ≥ 1.0 volt and that the **Ch2 Low** readout ≤ 0.25 volts.
 - Enter high and low voltages on test record.

- Press the side-menu button **Ω** to select the 1 MΩ setting. (This step is not required on the TDS794D – proceed to step 3. TDS694C skip the following steps and proceed to step 4.)
 - Press **CLEAR MENU**.
 - CHECK that the **Ch2 High** readout is ≥ 2.5 volts and that the **Ch2 Low** readout is ≤ 0.7 volts.
 - Enter high and low voltages on test record.
3. *Confirm CH 3 (AUX 1 on some TDS models except TDS694C) output is within limits for gain:*
- a. *Measure gain:*
- Move the precision 50 Ω cable from the rear-panel **DELAYED TRIGGER OUTPUT** BNC to the rear-panel **CH 3/AUX 1** BNC (**SIGNAL OUT** on some models).
 - Push **TRIGGER MENU**.
 - Press the main-menu button **Source**.
 - Press the side-menu button **Ch3**. (**Ax1** on some TDS models)
 - Set vertical **SCALE** to 100 mV.
 - Press **SET LEVEL TO 50%**.
 - Press **MEASURE**; then press the main-menu button **Select Measrmt for Ch2**.
 - Repeatedly press the side-menu button **–more–** until **Pk-Pk** appears in the side menu (its icon is shown at the left). Press the side-menu button **Pk-Pk**.
 - Press **CLEAR MENU**.
- b. *Check against limits: (Skip the first four subparts of this substep for the TDS 794D only.)*
- CHECK that the readout **Ch2 Pk-Pk** is between 80 mV and 120 mV, inclusive, for the TDS 600C or is between 88 mV and 132 mV, inclusive, for the TDS 500D/700D/714L.
 - Enter voltage on test record.
 - Press **VERTICAL MENU**; then press the side-menu button **Ω** to toggle to the 50 Ω setting.
 - Press **CLEAR MENU**.



- CHECK that the readout **Ch2 Pk-Pk** is between 40 mV and 60 mV, inclusive, for the TDS 600C or is between 44 mV and 66 mV, inclusive, for the TDS 500D/700D/714L.
 - Enter voltage on test record.
4. *Disconnect the hookup:* Disconnect the cables from the channel inputs and the rear panel outputs.

**Check Probe
Compensator Output**

Equipment required	One female BNC to clip adapter (Item 3) Two dual-banana connectors (Item 6) One BNC T connector (Item 7) Two precision 50 Ω coaxial cables (Item 5) One DC calibration generator (Item 9)
Prerequisites	See page 1–17. Also, the oscilloscope must have passed <i>Check Accuracy For Long-Term Sample Rate, Delay Time, and Delta Time Measurement</i> on page 1–56.

1. *Install the test hookup and preset the instrument controls:*
- a. *Hook up test-signal:*
- Connect one of the 50 Ω cables to **CH 1**. See Figure 1–21.
 - Connect the other end of the cable just installed to the female BNC-to-clips adapter. See Figure 1–21.
 - Connect the red clip on the adapter just installed to the **PROBE COMPENSATION SIGNAL** on the front panel; connect the black clip to **PROBE COMPENSATION GND**. See Figure 1–21.

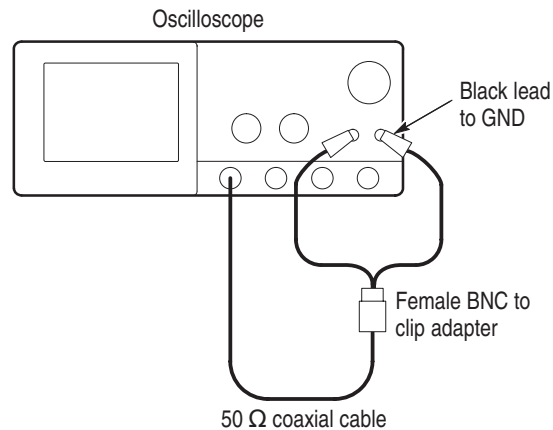

Figure 1–21: Initial test hookup

b. Initialize the oscilloscope:

- Press save/recall **SETUP**.
- Press the main-menu button **Recall Factory Setup**.
- Press the side-menu button **OK Confirm Factory Init**.

c. Modify the initialized front-panel control settings:

- Set the horizontal **SCALE** to 200 μ s.
- Press **SET LEVEL TO 50%**.
- Use the vertical **POSITION** knob to center the display on screen.
- Press **SHIFT**; then press **ACQUIRE MENU**.
- Press the main-menu button **Mode**; then press the side-menu button **Average**.
- Select **128** averages with the keypad or the general purpose knob.

2. Confirm that the Probe Compensator signal is within limits for frequency:

a. Measure the frequency of the probe compensation signal:

- Press **MEASURE**; then press the main-menu button **Select Measrmt for Ch1**.
- Repeatedly press the side-menu button **–more–** until **Frequency** appears in the side menu (its icon is shown at the left). Press the side-menu button **Frequency**.



b. Check against limits:

- CHECK that the **CH 1 Freq** readout is within 950 Hz to 1.050 kHz, inclusive. See Figure 1–22.
- Enter frequency on test record.
- Press **MEASURE**; then press the main-menu button **Remove Measrmt.** Press the side-menu **Measurement 1.**

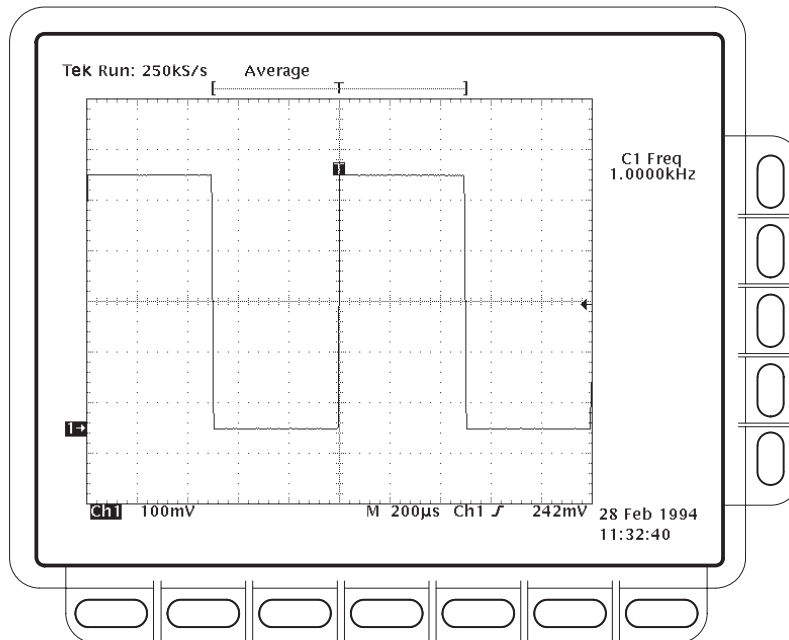

Figure 1–22: Measurement of probe compensator frequency

c. *Save the probe compensation signal in reference memory:*

- Press save/recall **WAVEFORM**; then press the main-menu button **Save Wfm Ch 1.**
- Press the side-menu button **To Ref 1** to save the probe compensation signal in reference 1.
- Disconnect the cable from **CH 1** and the clips from the probe compensation terminals.
- Press **MORE**; then press the main-menu button **Ref 1** to displayed the stored signal.
- Press **CH 1.**

d. *Hook up the DC standard source:*

- Set the output of a DC calibration generator to off or 0 volts.
- Connect the output of a DC calibration generator through a dual-banana connector followed by a 50 Ω precision coaxial cable to one side of a BNC T connector. See Figure 1–23.
- Connect the Sense output of the generator through a second dual-banana connector followed by a 50 Ω precision coaxial cable to the other side of the BNC T connector. Now connect the BNC T connector to **CH 1**. See Figure 1–23.

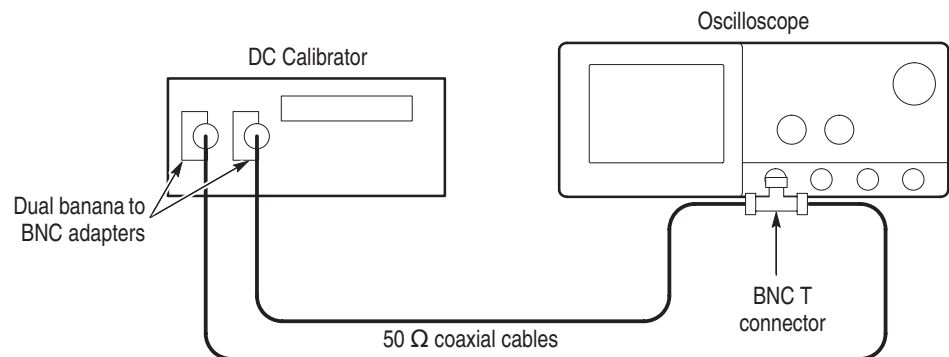

Figure 1–23: Subsequent test hookup

- e. *Measure amplitude of the probe compensation signal:*
 - Press **SHIFT**; then press **ACQUIRE MENU**. Press the side-menu button **AVERAGE** then enter 16 using the keypad or the general purpose knob.
 - Adjust the output of the DC calibration generator until it precisely overlaps the top (upper) level of the stored probe compensation signal. (This value will be near 500 mV).
 - Record the setting of the DC generator.
 - Adjust the output of the DC calibration generator until it precisely overlaps the base (lower) level of the stored probe compensation signal. (This value will be near zero volts).
 - Record the setting of the DC generator.
- f. Press **CLEAR MENU** to remove the menus from the display. See Figure 1–24.

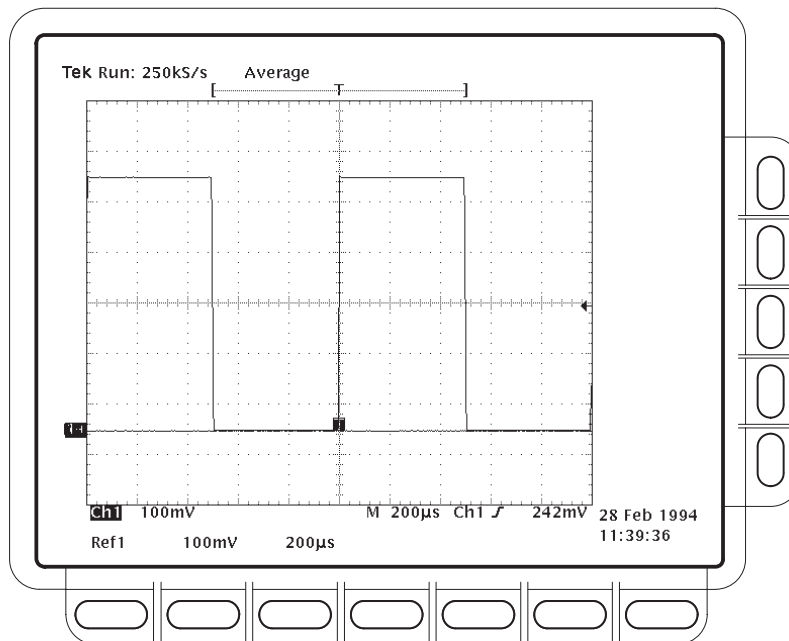

Figure 1–24: Measurement of probe compensator amplitude

g. *Check against limits:*

- Subtract the value just obtained (base level) from that obtained previously (top level).
- CHECK that the difference obtained is within 495 mV to 505 mV, inclusive.
- Enter voltage difference on test record.

3. *Disconnect the hookup:* Disconnect the cable from **CH 1**.

Option 05 Video Trigger Checks (Not Available on TDS694C or TDS794D)

Check Video Trigger	Equipment required	PAL signal source (Item 21) 60 Hz sine wave generator (Item 22) Pulse generator (Item 23) Two 75 Ω cables (Item 24) Two 75 Ω terminators (Item 25) One BNC T connector (Item 7) One precision 50 Ω coaxial cable (Item 5) 50 Ω terminator (Item 4)
	Prerequisites	See page 1–17. These prerequisites include running the signal path compensation routine.

1. *Set up the oscilloscope to factory defaults by completing the following steps:*
 - a. Press save/recall **SETUP**.
 - b. Press the main-menu **Recall Factory Setup**.
 - c. Press the side-menu **OK Confirm Factory Init**.
 - d. Wait for the Clock Icon to leave the screen.
 - e. CONFIRM the oscilloscope is setup as shown below.
 Channel: CH1
 Volt/div: 100 mV
 Horizontal scale: 500 μ s/div
2. *Set up the oscilloscope for TV triggers by completing the following steps:*
 - a. Press **TRIGGER MENU**.
 - b. Press the main-menu **Type** pop-up until you select **Video**.
 - c. Press the main-menu **Standard** pop-up until you select **625/PAL**.
 - d. Press the main-menu **Line**.
 - e. Use the keypad to set the line number to 7 (press **7**, then **ENTER**).
 - f. Press **VERTICAL MENU**.
 - g. Press the main-menu **Bandwidth**.

- h. Select **250 MHz** from the side menu.
 - i. Press the main-menu **Fine Scale**.
 - j. Press **HORIZONTAL MENU**.
 - k. Press the main-menu **Horiz Scale**.
 - l. Use the keypad to set the horizontal scale to 200 ns (press **200**, **SHIFT**, **n**, then **ENTER**).
 - m. Use the Vertical Position knob to center the waveform on screen.
3. *Check Jitter vs. Signal Amplitude*
- a. Set up equipment for Jitter Test. See Figure 1–25.
 - Connect one of the rear panel composite outputs marked **COMPST** on the TSG121 through a 75 Ω cable and a 75 Ω terminator to the CH1 input of the oscilloscope.
 - Press the **100% FIELD** control (the fourth TSG121 front-panel button from the left) of the PAL signal source.

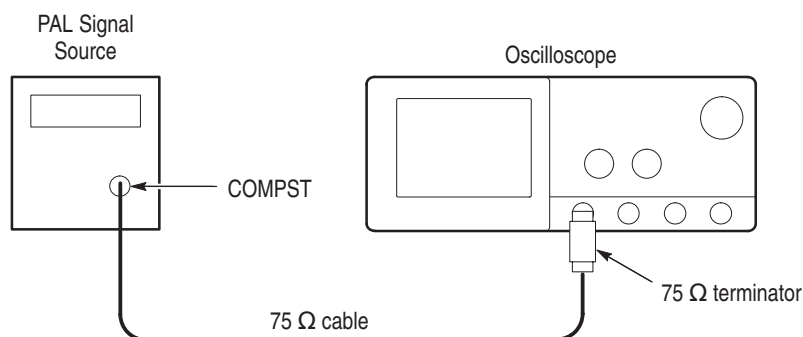

Figure 1–25: Jitter test hookup

- b. CHECK that the oscilloscope lights up its front panel **TRIG'D** LED and it displays the waveform on screen. See Figure 1–26.

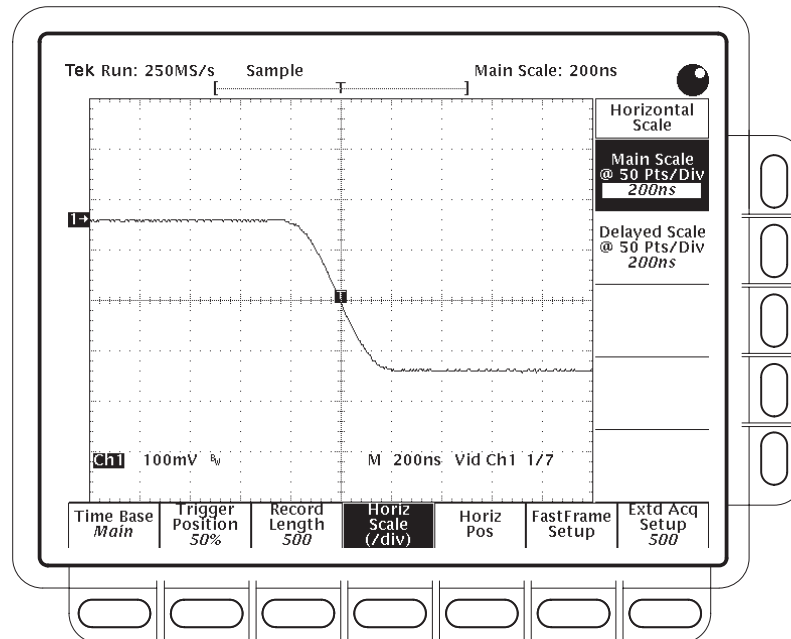

Figure 1-26: Jitter test displayed waveform – TDS 754D shown

- c. Press **SHIFT**; then press **ACQUIRE MENU**.
 - d. Press the main-menu **Mode**.
 - e. Press the side-menu **Envelope**.
 - f. Use the keypad to set envelope to use 100 acquisitions (press **100**, then **ENTER**).
 - g. Press the main-menu **Stop After** button.
 - h. Press the side-menu **Single Acquisition Sequence**.
 - i. Wait for the word **Run** in the top left corner of the display to change to **STOP**.
4. *Perform Check Trigger Jitter.*

Set up Oscilloscope for the Trigger Jitter Test.

 - a. Press **DISPLAY**.
 - b. Press the main-menu **Format/RO**.
 - c. Press the side-menu **Display 'T' @ Trigger Point** until you select **OFF**.
 - d. Press **CURSOR**.

- e. Press the side-menu **V-Bars**.
- f. Use the general purpose knob to move the left cursor to the right until the @ measurement reads -32 ns.
- g. Press **SELECT**.
- h. Use the General Purpose knob to adjust the right cursor until the delta measurement reads 60 ns.
- i. CONFIRM that the width of the falling edge of the trace (at the center crossings) falls between the cursors. See Figure 1–27.
- j. Press **DISPLAY**.
- k. Press the main-menu **Format/RO**.
- l. Press the side–menu **Display ‘T’ @ Trigger Point** until you select **ON**.

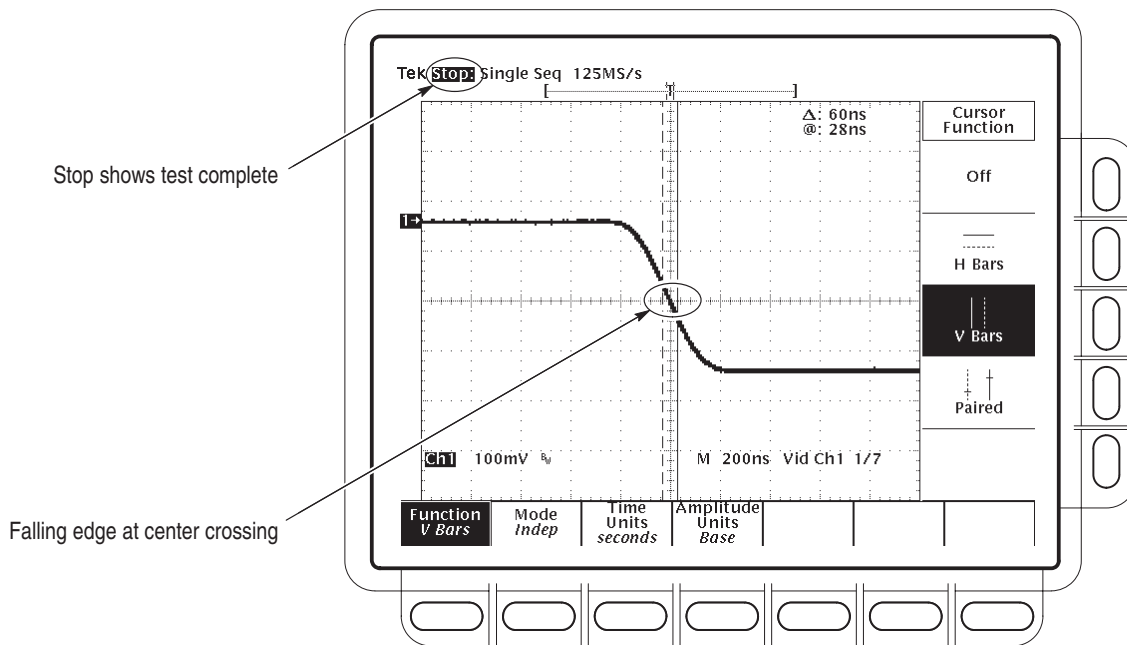

Figure 1–27: Jitter test when completed – TDS 754D shown

5. *Check Triggered Signal Range.*

Set up oscilloscope for Triggered Signal Test.

- a. Press **MORE**.
- b. Press **WAVEFORM OFF**.

- c. Press **HORIZONTAL MENU**.
- d. Use the keypad to set horizontal scale (/div) to 50 μ s (press **50**, **SHIFT**, **μ** , then **ENTER**).
- e. Press **SHIFT**; then press **ACQUIRE MENU**.
- f. Press the main-menu **Stop After**.
- g. Press the side-menu **RUN/STOP button only**.
- h. Press the main-menu **Mode**.
- i. Press the side-menu **Sample**.
- j. Press **RUN/STOP**.
- k. Press **VERTICAL MENU**.
- l. Use the keypad to set fine scale to 300 mV (press **300**, **SHIFT**, **m**, then **ENTER**).
- m. CONFIRM that the **TRIG'D LED** stays lighted and that the waveform on screen is stable. Also, CONFIRM that the waveform on the screen has one positive pulse and a number of negative pulses. See Figure 1–28.

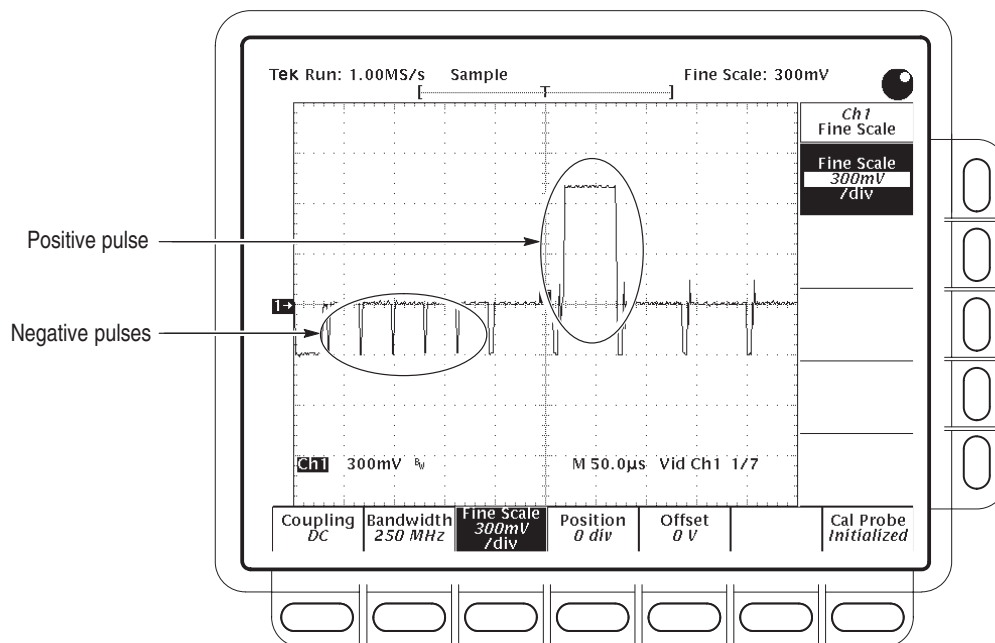

Figure 1–28: Triggered signal range test – 300 mV

- n. Use the keypad to set the fine scale to 75 mV (press **75**, **SHIFT**, **m**, then **ENTER**).
- o. CONFIRM that the **TRIG'D** LED stays lighted and that the waveform on screen is stable. That is, it does not move horizontally or vertically. Also, CONFIRM that the waveform on the screen has one positive pulse and a number of negative pulses. See Figure 1–29.

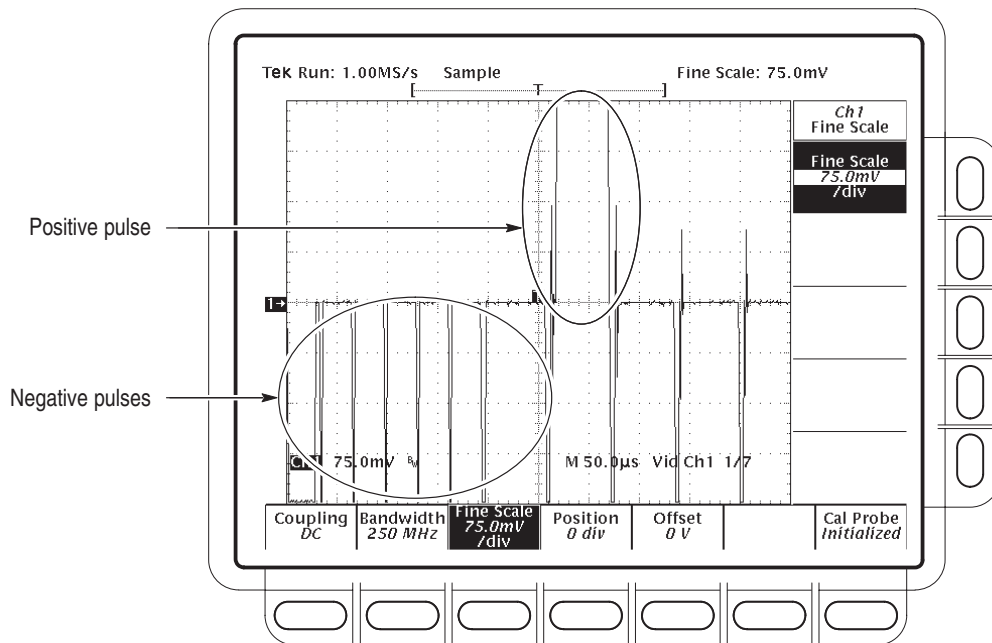

Figure 1–29: Triggered signal range test – 75 mV

- p. Disconnect all test equipment (TSG121) from the oscilloscope.
- 6. Check 60 Hz Rejection.**
- a. *Set up oscilloscope for 60 Hz Rejection Test:*
 - Use the keypad to set the Ch1 Fine Scale to 282 mV (press **282**, **SHIFT**, **m**, then **ENTER**).
 - Press **WAVEFORM OFF**.
 - Press **CH2**.
 - Press **VERTICAL MENU**.
 - Use the keypad set the fine scale to 2 V (press **2**, then **ENTER**).
 - Press **HORIZONTAL MENU**.

- Use the keypad to set the horizontal scale (/div) to 5 ms (press **5**, **SHIFT**, **m**, then **ENTER**).
- b. *Set up 60 Hz signal generator:*
- Connect the output of the signal generator to the CH2 input through a 50 Ω cable. See Figure 1–30.

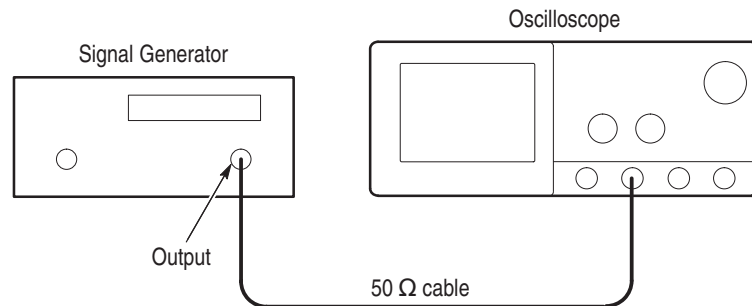

Figure 1–30: 60 Hz Rejection test hookup

- Adjust the signal generator for three vertical divisions of 60 Hz signal. See Figure 1–31. The signal will not be triggered. That is, it will run free.

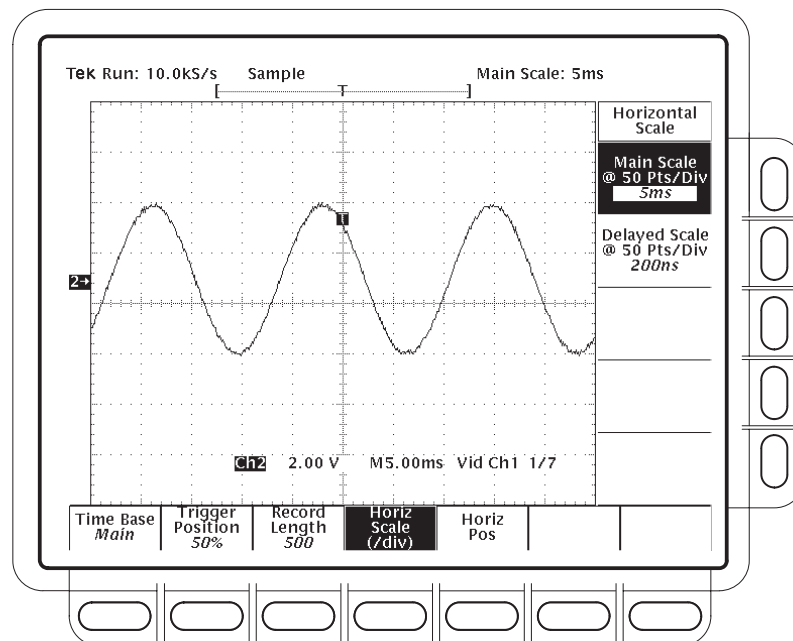

Figure 1–31: 60 Hz Rejection test setup signal

c. Check 60 Hz rejection:

- Use the keypad to set the horizontal scale (/div) to $50\ \mu\text{s}$ (press **50**, **SHIFT**, **μ** , then **ENTER**).
- Reconnect the output of the signal generator. Connect the composite signal connector of the PAL signal source (labeled **COMPST** on the TSG 121) to a $75\ \Omega$ cable and a $75\ \Omega$ terminator. Connect both signals to the CH1 input through a BNC T. See Figure 1–32.
- Press **VERTICAL MENU**.
- If needed, press the main-menu **Fine Scale**.
- Use the keypad to set fine scale to 500 mV (press **500**, **SHIFT**, **m**, then **ENTER**).
- Connect another composite signal connector of the PAL signal source (labeled **COMPST** on the TSG 121) through a $75\ \Omega$ cable and a $75\ \Omega$ terminator to the CH2 input. See Figure 1–32.

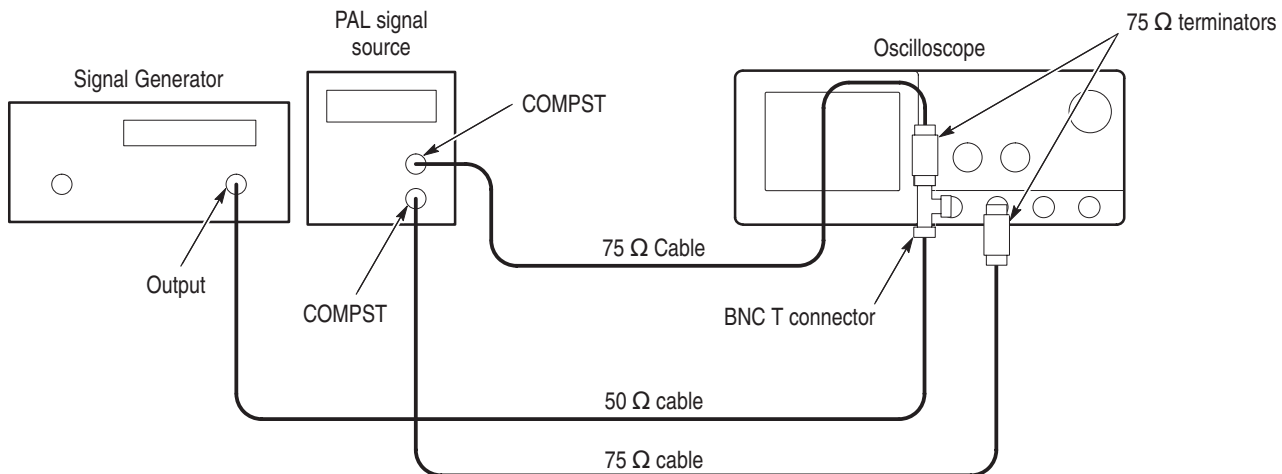

Figure 1–32: Subsequent 60 Hz Rejection test hookup

- CONFIRM that the **TRIG'D** LED stays lighted and that the waveform on screen is stable. In other words, be sure the waveform does not move horizontally or vertically. Also, confirm that the waveform on the screen has one positive pulse and a number of negative pulses. See Figure 1–33.
- Disconnect all test equipment from the oscilloscope.

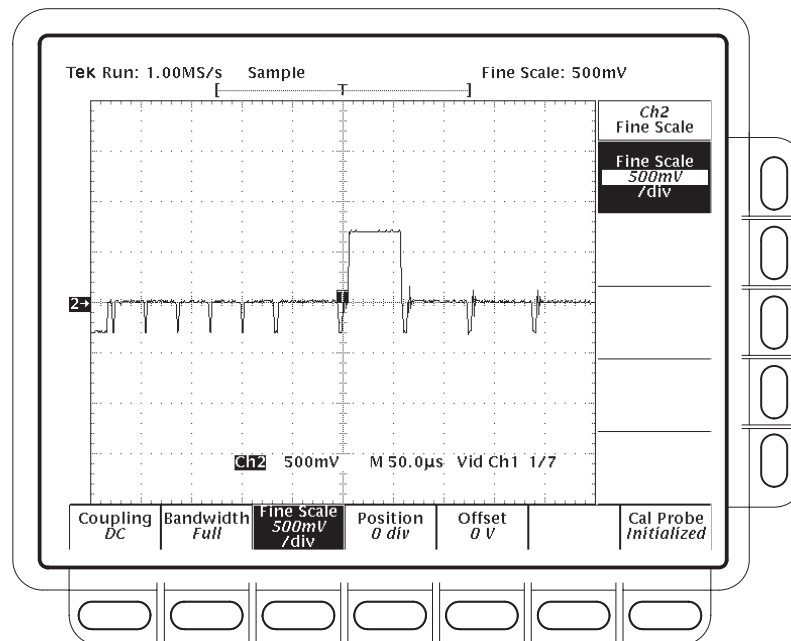

Figure 1–33: 60 Hz Rejection test result – TDS 684C shown

7. *Check Line Count Accuracy.*

a. *Set up oscilloscope for Line Count Accuracy Test:*

- Press **WAVEFORM OFF**.
- Press **CH1**.
- Press **HORIZONTAL MENU**.
- Press the main-menu **Record Length**.
- Press the side-menu **–more–** until you see the appropriate menu.
- Press the side-menu **5000 points in 100divs**.
- Press the main-menu **Horiz Scale (/div)**.
- Use the keypad to set the horizontal scale to 200 ns (press **200**, **SHIFT**, **n**, then **ENTER**).

b. *Check Line Count Accuracy:*

- Connect a composite output signal from the rear of the PAL signal source (labeled **COMPST** on the TSG 121) to the CH1 input through a 75 Ω cable and a 75 Ω terminator. See Figure 1–34.

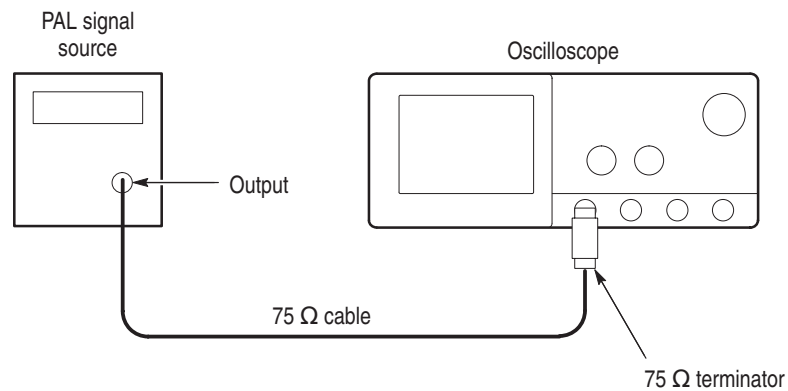

Figure 1–34: Line count accuracy test hookup

- Press the main-menu **Trigger Position**.
- Press the side-menu to **Set to 50%**.
- Press the main-menu to **Horiz Pos**.
- Press the side-menu to **Set to 50%**.
- Use the **HORIZONTAL POSITION** knob to move the falling edge of the sync pulse to two divisions to the left of center screen. See Figure 1–35.

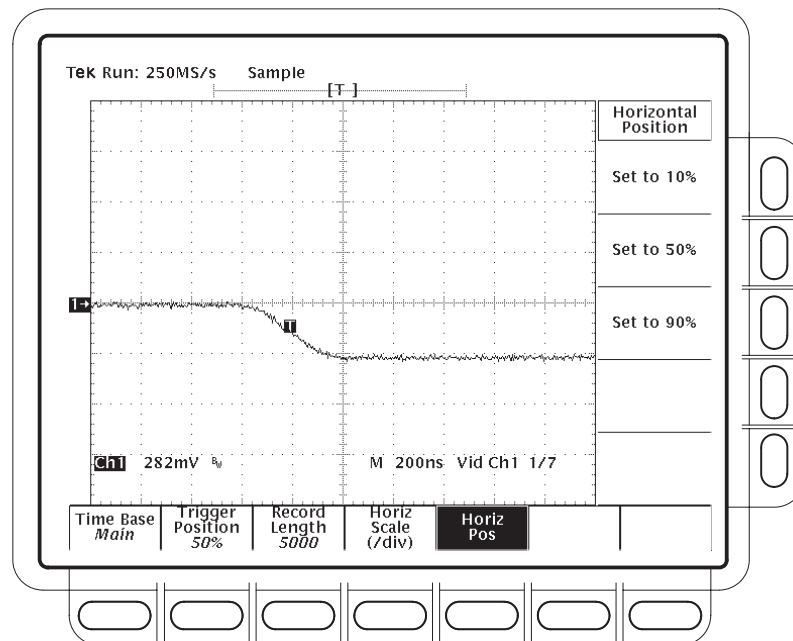

Figure 1-35: Line count accuracy test setup waveform – TDS 684C shown

- Press **CURSOR**.
- Press the main-menu **Function**.
- Press the side-menu **V Bars**.
- Using the General Purpose knob, place the left cursor directly over the trigger 'T' icon.
- Press **SELECT**.
- Turn the General Purpose knob to adjust the right cursor for a cursor delta reading of **6.780us**.
- Use the **HORIZONTAL POSITION** knob to position the right cursor to center screen.
- Verify that the cursor is positioned on a positive slope of the burst signal. See Figure 1-36.

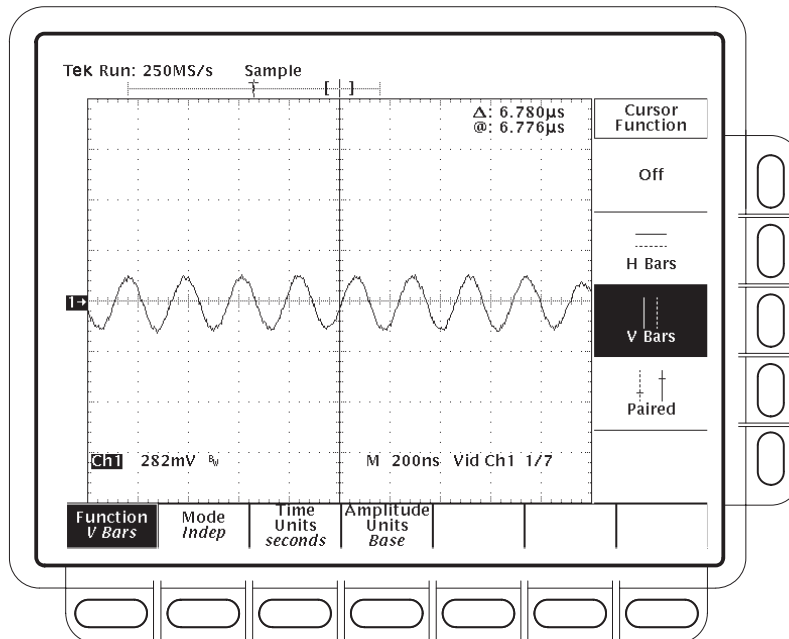

Figure 1-36: Line count accuracy correct result waveform

- Disconnect all test equipment (TSG 121) from the oscilloscope.
 - Turn off cursors by pressing **CURSOR**, then the main-menu **Function** button, and, finally, **Off** from the side menu.
8. *Check the Sync Duty Cycle.*
- a. *Set up oscilloscope for Sync Duty Cycle Test:*
- Press **TRIGGER MENU**.
 - Press the **Standard** pop-up to select **FlexFmt**. Trigger **Type** should already be set to **Video**.
 - Press the main-menu **Setup**.
 - Press the side-menu **Field Rate**.
 - Use the keypad to set the field rate to 60.05 Hz (press **60.05**, then **ENTER**).
 - Press the side-menu **Lines**.
 - Use the keypad to set the field rate to 793 lines (press **793**, then **ENTER**).
 - Press the side-menu **Fields**.

- Use the keypad to set the number of fields to 1 (press **1**, then **ENTER**).
 - Press the side-menu **Sync Width**.
 - Use the keypad to set the width to 400 ns (press **400**, **SHIFT**, **n**, then **ENTER**).
 - Press the side-menu **–more– 1 of 2**. Then press **V1 Start Time**.
 - Use the keypad to set V1 start time to 10.10 μ s (press **10.10**, **SHIFT**, **μ** , then **ENTER**).
 - Press the side-menu **V1 Stop Time**.
 - Use the keypad to set V1 stop time to 10.50 μ s (press **10.50**, **SHIFT**, **μ** , then **ENTER**).
 - Press the main-menu **Type** pop-up to select **Edge**.
 - Press **HORIZONTAL MENU**.
 - Press the main-menu **Record Length**.
 - Select the side-menu **1000 points in 20div**. If needed, first press the side-menu **–more–** until you see the appropriate side-menu item.
 - Turn the **HORIZONTAL POSITION** knob to position the trigger ‘T’ two divisions to the left of the center screen.
 - Press **MEASURE**.
 - If needed, press the main-menu **Select Measrmt**.
 - Press the side-menu **Negative Width**.
 - Press the side-menu **Period**.
- b. *Set up the pulse generator for Sync Duty Cycle Test:*
- Set **PULSE DURATION** to 50 ns.
 - Set **PERIOD** to 10 μ s.
 - Set **OUTPUT (VOLTS)** to **–1** for **LOW LEVEL** and **+1** for **HIGH LEVEL**.
 - Depress the **COMPLEMENT** button.
 - Be sure **BACK TERM** is depressed (in).

c. *Check Sync Duty Cycle:*

- Connect the pulse generator through a 50 Ω cable and a 50 Ω terminator to the oscilloscope CH1 input. See Figure 1–37.

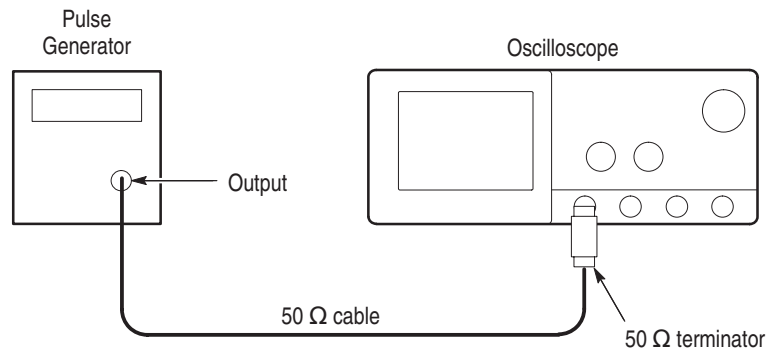

Figure 1–37: Setup for sync duty cycle test

- Turn the pulse generator **OUTPUT (VOLTS)** control until the signal on the oscilloscope shows a one division negative-going pulse. See Figure 1–38.

NOTE. *You may need to adjust the trigger level control to obtain a stable trigger.*

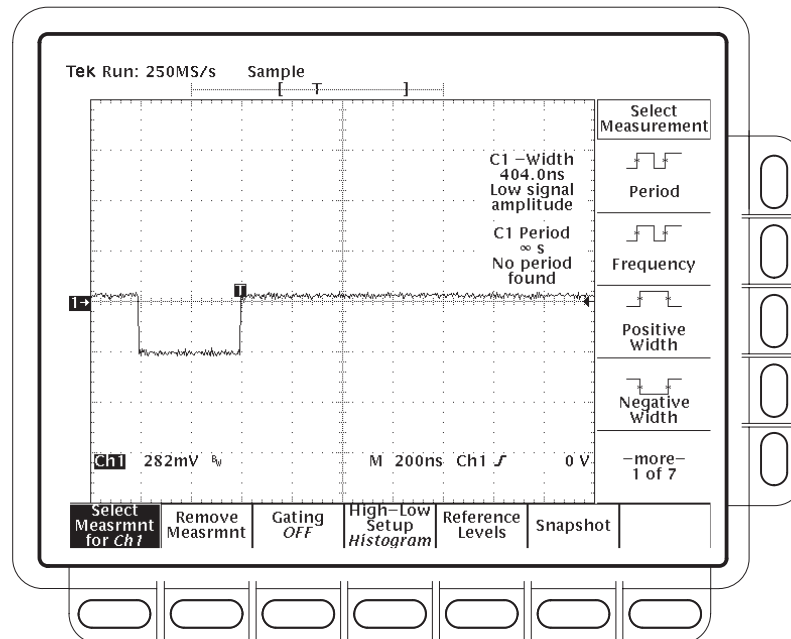

Figure 1–38: Sync duty cycle test: one-div neg pulse waveform

- Turn the pulse generator **PULSE DURATION** variable control to adjust the negative pulse so the oscilloscope's **CH1 – Width** measurement displays **400ns +/-10 ns**.
- Turn the **HORIZONTAL SCALE** knob to set the oscilloscope time base to **5µs/div**.
- Turn the pulse generator **PERIOD** variable control to adjust the period until the oscilloscope **CH1 Period** measurement reads **21.000µs -25/+50 ns**. See Figure 1–39. Read note shown below.

NOTE. The pulse duration and period adjustments are critical in making this measurement. If the pulse duration and/or the duty cycle are not stable, the **FLEXFMT** function may not function. You must take care when making these adjustments.

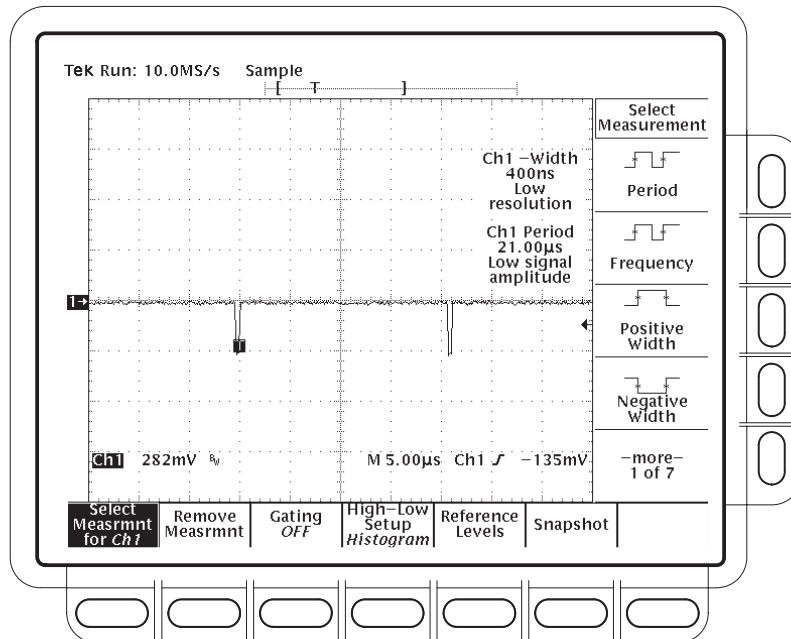

Figure 1-39: Sync duty cycle test: critically adjusted pulse

- Press **TRIGGER MENU**.
- Press the main-menu **Type** pop-up until you select **Video**.
If the **TRIG'D** LED is not lighted, check that the **CH1 – Width** and **CH1 Period** measurements are adjusted correctly. See note above. CONFIRM that the setup is correct and the oscilloscope will trigger.
- CONFIRM that the **TRIG'D** LED is lighted and the waveform is stable.
- Disconnect the signal source from CH1, wait a few seconds, then reconnect the signal.
- CONFIRM that the **TRIG'D** LED is lighted and the waveform is stable.
- Press **Sync Polarity**.
- Press **Pos Sync**.
- Push the pulse generator **COMPLEMENT** button out.
- CONFIRM that the **TRIG'D** LED is lighted and the waveform is stable.

- Disconnect the signal source from CH1, wait a few seconds, then reconnect the signal.
- CONFIRM that the **TRIG'D** LED is lighted and the waveform is stable.
- Disconnect all test equipment from the oscilloscope.
- Press save/recall **SETUP**, the main-menu button **Recall Factory Setup**, and the side-menu **OK Confirm Factory Init**.

Sine Wave Generator Leveling Procedure

Some procedures in this manual require a sine wave generator to produce the necessary test signals. If you do not have a leveled sine wave generator, use one of the following procedures to level the output amplitude of your sine wave generator.

Equipment required	Sine wave generator (Item 14) Level meter and power sensor (Item 15) Power divider (Item 16) Two male N to female BNC adapters (Item 17) One precision coaxial cable (Item 5)
Prerequisites	See page 1-17

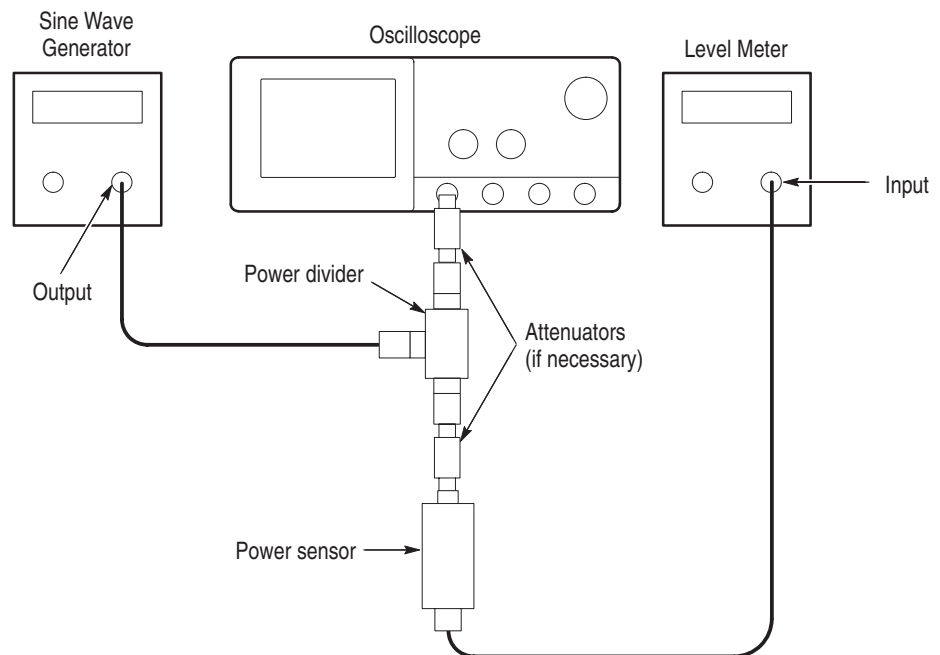

Figure 1-40: Sine wave generator leveling equipment setup

1. *Install the test hookup:* Connect the equipment as shown in Figure 1-40.
2. *Set the Generator:*
 - Set the sine wave generator to a reference frequency of 10 MHz.

- Adjust the sine wave generator amplitude to the required number of divisions as measured by the oscilloscope.
3. *Record the reference level:* Note the reading on the level meter.
 4. *Set the generator to the new frequency and reference level:*
 - Change the sine wave generator to the desired new frequency.
 - Input the correction factor and/or the new frequency into the level meter.
 - Adjust the sine wave generator amplitude until the level meter again reads the value noted in step 3. The signal amplitude is now correctly set for the new frequency.

Equipment required	Sine wave generator (Item 14) Level meter and power sensor (Item 15) Two male N to female BNC adapters (Item 17) Two precision coaxial cables (Item 5)
Prerequisites	See page 1–17

1. *Install the test hookup:* Connect the equipment as shown in Figure 1–41 (start with the sine wave generator connected to the oscilloscope).

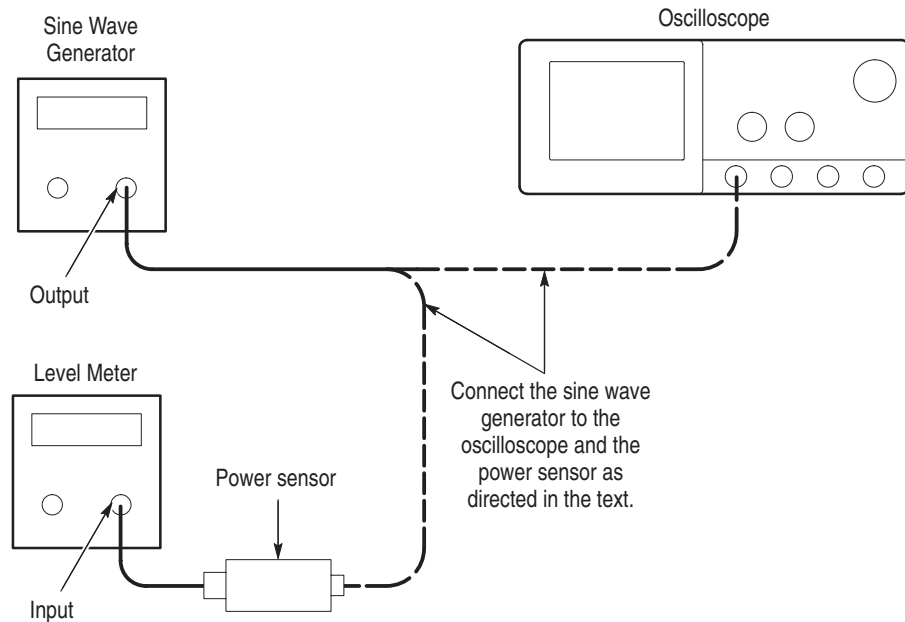

Figure 1-41: Equipment setup for maximum amplitude

2. Set the Generator:

- Set the sine wave generator to a reference frequency of 10 MHz.
- Adjust the sine wave generator amplitude to the required number of divisions as measured by the oscilloscope.

3. Record the reference level:

- Disconnect the sine wave generator from the oscilloscope.
- Connect the sine wave generator to the power sensor.
- Note the level meter reading.

4. Set the generator to the new frequency and reference level:

- Change the sine wave generator to the desired new frequency.
- Input the correction factor and/or the new frequency into the level meter.
- Adjust the sine wave generator amplitude until the level meter again reads the value noted in step 3. The signal amplitude is now correctly set for the new frequency.
- Disconnect the sine wave generator from the power sensor.
- Connect the sine wave generator to the oscilloscope.

Optical Filter Checks (Options 2C, 3C & 4C Only)

The procedure that follows verifies that the frequency response of the combined P670xB and TDS500D/700D oscilloscope system is a Fourth Order Bessel Thompson Filter which is within limits.

Filter Availability

Nominal Filters are available with Option 2C. Reference Receiver Filters are available with Options 3C and 4C. Options 3C and 4C are not available without 2C, and 3C and 4C are not available on the TDS 794D.

You can verify Option 2C is enabled on the TDS 794D by pressing **MEASURE**, then selecting **Masks** from the Measure pop-up menu. Table 1–7 lists the available vertical scale factors for each option. Tables 1–8, 1–9, and 1–10 list the available filters and their specifications.

Table 1–7: Available filters

Nominal Filters (Option 2C)	Reference Receivers Filters (Options 3C, 4C)
1 μ W per division	
2 μ W per division	
5 μ W per division	
10 μ W per division	10 μ W per division
20 μ W per division	20 μ W per division
50 μ W per division	50 μ W per division
100 μ W per division	
200 μ W per division	
500 μ W per division	
1 mW per division	

Table 1–8: Reference receiver filter options

Option 4C – SONET (P6703B 1300nm)	Option 3C – Fibre Channel (P6701B 850nm)
52Mbit OC1	FC133Mbit
	FC266Mbit
	FC531Mbit
155Mbit OC3	155Mbit OC3
622Mbit OC12	622Mbit OC12
FC1063 (TDS 784D Only)	FC1063 (TDS 784D Only)

Table 1–9: Option 3C and 4C specifications

Name	Description
Calibration Range, Reference Receiver	10 μ W per division 20 μ W per division 50 μ W per division
Temperature Range, Warranted Filter	23° C, \pm 5° C
Calibration Range, Controlled	Up to 2X the data rate for all filters except FC1063 filter Up to 1.5X the data rate for FC1063 filter

Table 1–10: Available receivers

	Option 4C ¹				Option 3C ²					
	OC1 ⁴	OC3	OC12	FC1063 ³	FC133	FC266	FC531	FC1063 ³	OC3	OC12
TDS 520D	✓	✓			✓				✓	
TDS 540D	✓	✓	✓		✓	✓	✓		✓	✓
TDS 580D	✓	✓	✓	✓	✓	✓	✓	✓	✓	✓
TDS 724D	✓	✓			✓				✓	
TDS 754D	✓	✓	✓		✓	✓	✓		✓	✓
TDS 784D	✓	✓	✓	✓	✓	✓	✓	✓	✓	✓

¹ Requires Tektronix P6703B, 1300 nm Optical to Electrical Converter.

² Requires Tektronix P6701B, 850 nm Optical to Electrical Converter.

³ Reference receivers are warranted to 2.0 times the bit rate except for FC1063 which is warranted to 1.5 times the bit rate.

⁴ OC1 is type tested

Reference Receiver Verification

Equipment required	OIG501 (use with P6701B) (Item 26) OIG502 (use with P6703B) (Item 27) Optical Attenuator OA5022 (Item 34) Fiber Optic Cable (Item 35) Optical-to-Electrical Converter (item 36)
Prerequisites	See page 1–17. Also, the probe and the oscilloscope channel it is attached to must have been calibrated as a reference receiver.

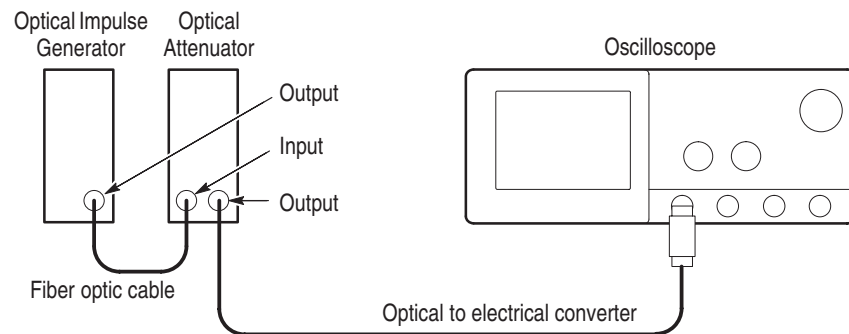
1. Install the test hookup and preset the instrument controls:**Figure 1–42: Reference-receiver performance-verification set up**

- a. *Initialize the oscilloscope:*
 - Press **SAVE/RECALL SETUP**.
 - Press the main-menu button **Recall Factory Setup**.
 - Press the side-menu button **OK Confirm Factory Init**.
- b. *Connect the probe, oscilloscope, optical impulse generator (OIG), and the optical attenuator:*
 - Connect the optical probe to CH 1 of the oscilloscope under test (see Figure 1–42).
 - See Table 1–10. If using a P6701B probe, connect the OIG501 (Item 26) **OPTICAL OUTPUT** to the optical attenuator (Item 34) **OPTICAL INPUT** using a fiber-optic cable (Item 35). If using a P6703B probe, connect the OIG502 (Item 27) **OPTICAL OUTPUT** to the optical attenuator (Item 34) **OPTICAL INPUT** using a fiber-optic cable (Item 35).

- Connect the optical probe on CH 1 of the oscilloscope to the OPTICAL OUTPUT of the optical attenuator using the fiber-optic cable of the probe. Set an optical impulse level that does not clip the vertical channel of the oscilloscope.
- c. Set up the OIG to run with LOW impulse energy.
 - Keep the impulse below 100 μW peak level because high-energy impulses into the P670x probe will cause major changes in the frequency response of the probe.
 - Set the OIG for 1 MHz internal trigger.
 - Set the OIG for the wavelength shown in Table 1–10 that is required for the standard and option you are verifying.
- d. Enable the laser.
- e. Set the VERTICAL SCALE of the oscilloscope to either 10 μW , 20 μW or 50 μW /division.

NOTE. These are the only scale settings for which the reference receivers have calibrated filters.

- f. *Set the trigger type to edge:*
 - Press **TRIGGER MENU**; then select **Edge** from the Type pop-up menu.
 - Press **SET LEVEL TO 50%**.
- g. Set the HORIZONTAL SCALE to 500 ps.
- h. Set the Optical Attenuator for several divisions of display on the oscilloscope.
- i. *Set the horizontal controls:*
 - Press **HORIZONTAL MENU**; then press the main-menu button **Record Length**. If Fit To Screen is not OFF, press **Fit to Screen** to toggle it to the **OFF** setting. Fit to Screen needs to be OFF so that the FFT waveform horizontal scale can be adjusted to obtain the desired display of the frequency response.
 - To obtain a 10000 point FFT in step 3, press **HORIZONTAL MENU**; then press the main-menu button **Record Length**. Then repeatedly press the side-menu button **–more–** until **15000** appears in the side menu. Press the side-menu button **15000**.

- Press **HORIZONTAL MENU**; then press the main-menu button **Trigger Position**. Set the Trigger Position to **20%** using the general purpose knob or keypad.

NOTE. Press **SHIFT** to change the horizontal position speed. The position moves faster when **SHIFT** is lighted.

- Adjust the **HORIZONTAL POSITION** to move the 20% trigger point onto the display (see Figure 1–43).

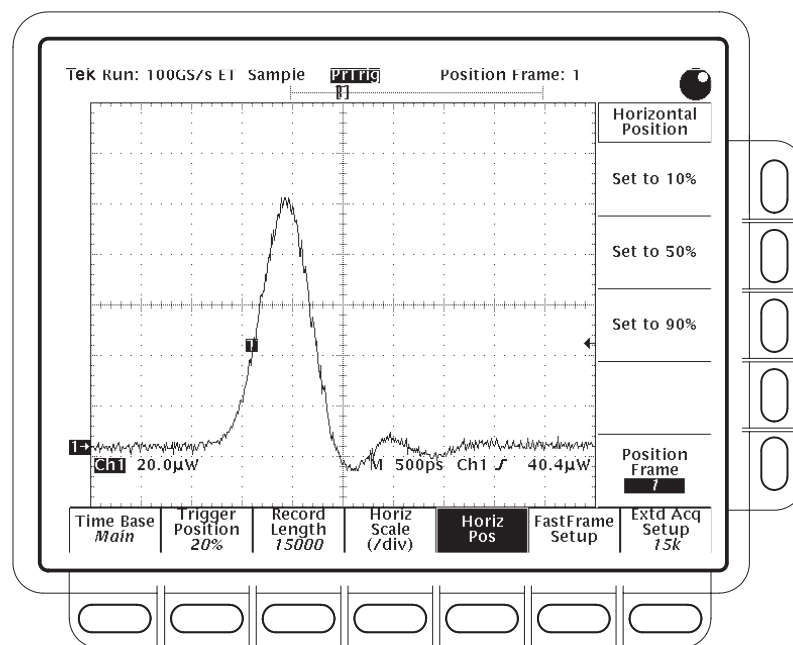

Figure 1–43: Optical impulse of Ch1 input from OA5022 Optical Attenuator (OIG501 / OIG502 fed into optical attenuator in Step 1)

- j. *Select linear interpolation:*
 - If **SHIFT** is lighted, press **SHIFT**.
 - Press **DISPLAY**; then press the main-menu button **Filter**.
 - Press the side-menu button **Linear Interpolation**.
2. *Select the desired Mask standard and turn it on:*
 - Press **MEASURE**; then select **Masks** from the Measure pop-up menu.

NOTE. <xxx> is the standard that you are verifying (such as OC1, OC3, OC12, FC1063; see Table 1–11 on page 1–106).

- From the Mask Type pop-up menu, select the mask type (<xxx>) of your reference receiver.
- Press the **Standard Mask** main menu; then select your reference receiver mask (<xxx>) from the side menu.

NOTE. For the Bessel Thompson (BT) filter to be active, the VERTICAL MENU deskew must be set to zero on all four channels. Also, the ACQUIRE MENU Acquisition Mode must be Sample. If you did the Factory Setup specified in Step 1a, you selected these modes.

- If checking a reference receiver, verify that RR is displayed to the right of the vertical scale factor (see Figure 1–44 on page 1–104).
 - Press **TRIGGER MENU**; then select **Edge** from the Type pop-up menu.
3. Turn on an FFT of the optical impulse [the Impulse Response (or Frequency Response) of the P670xB and oscilloscope system] (Refer to Figure 1–45 on page 1–105):
- a. Press the front panel **MORE** button; then press the main-menu button **Math2**. This turns on a math waveform.
 - b. If the math waveform is not set to FFT, create an FFT waveform:
 - Press **Change Math waveform definition**; then press the main-menu button **FFT**.
 - Press the side-menu button **Set FFT source to Ch1**.

NOTE. Verify the FFT window is set to Rectangular. Also verify the FFT Vert Scale is set to dBV RMS. If you did the Factory Setup in Step 1a, you selected these modes.

- Press the side-menu button **OK Create Math Waveform**.
- Press the side menu button **Average**, then set the number of averages to **16** using the general purpose knob or keypad.

-
4. Move the beginning of the FFT data record onto the screen:

NOTE. Press **SHIFT** to change the horizontal position speed. The position moves faster when **SHIFT** is lighted.

- Adjust the **HORIZONTAL POSITION** control to move the beginning of the FFT data record onto the display.

NOTE. Expanding the horizontal scale of the FFT waveform gives greater resolution when making cursor measurements. Expand the FFT to display DC to the highest frequency listed in Table 1–11 for the standard being verified.

- Adjust the **HORIZONTAL SCALE** and **VERTICAL SCALE** to view the frequency response of the BT filter. The large spike around DC is due to DC offset in the signal and should be ignored.
5. Observe the desired response characteristics using the vertical paired cursors (see figures 1–44 and 1–45):
- a. Press **CURSOR**.
 - b. Press the main-menu button **Function**; then press the side-menu button **Paired**.
 - c. Press **CLEAR MENU**.

NOTE. Pressing **SHIFT** will change cursor speed. Use the select key to alternate between cursors.

- d. Position one cursor at the beginning of the FFT record.
- e. Position the other cursor at the bit rate (the frequency closest to the bit rate) of the mask that is turned on (see Table 1–11 and Figure 1–44).

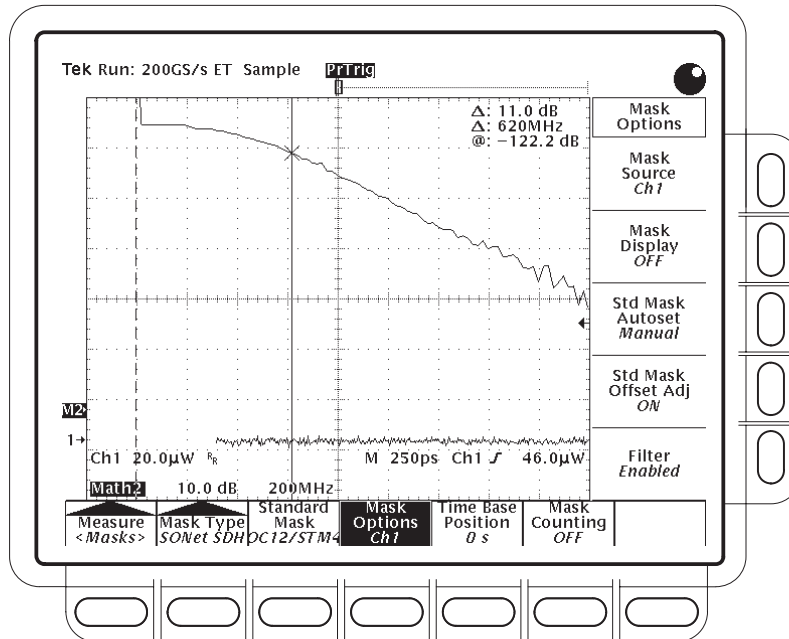

Figure 1-44: Optical impulse response for OC-12 SONET Reference Receiver

NOTE. In Figure 1-44, the left cursor is at the DC frequency. The right cursor is at the OC-12 data rate of 622 MHz \pm 4 MHz. Also, note that the reference receiver, RR, designation is beside the 20 μW vertical scale factor.

- f. Next, move the cursor currently positioned at the beginning of the record until the cursor is just right of the DC spike in the response (see Figure 1-45 on page 1-105). The unsigned Δ dB readout should be at or between the upper and lower limits shown in Table 1-11 on page 1-106 (note that the entries in the table are signed numbers, but the Δ dB readout is not) for the mask that is turned on.

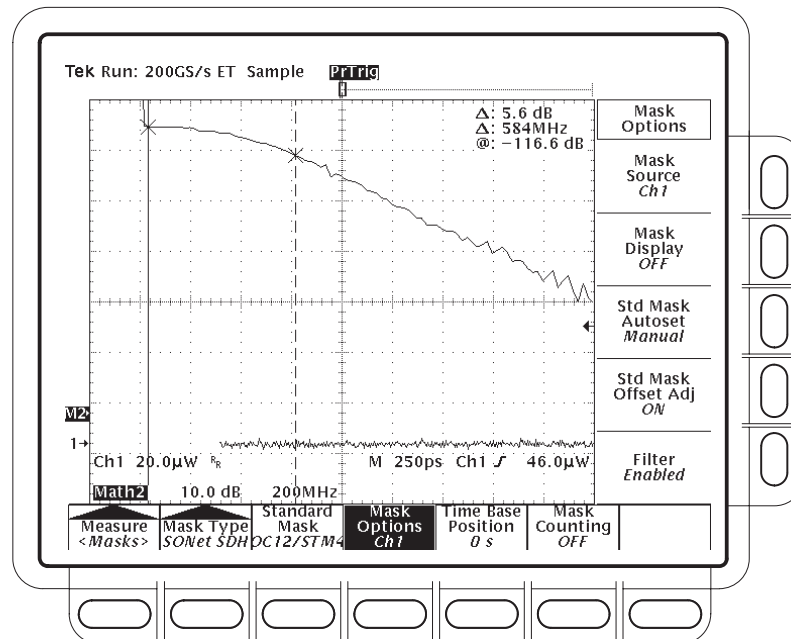

Figure 1–45: Optical impulse response for OC–12 SONET Reference Receiver

NOTE. In Figure 1–45 the left cursor has been moved to the zero dB level. The right cursor remains at the OC–12 data rate of 622 MHz \pm 4 MHz (the delta frequency is 584 MHz because the right cursor is no longer referenced to DC). The delta attenuation from the zero dB level to the 622 MHz Cursor is 5.6 dB.

6. Repeat steps 5d through 5f, starting on page 1–103, moving the second cursor to twice the bit rate (1.5 times the bit rate for the FC1063 standard).
7. For an exhaustive test of the reference receiver, repeat steps 5d through 5f for each frequency shown in Table 1–11 on page 1–106 for the standard.
8. If verifying additional standards, repeat this procedure for each standard.

Table 1–11: Bessel Thompson frequency response and reference receiver limits

Standard	Frequency (MHz)	Lower Limit (dB)	Nominal (dB)	Upper Limit (dB)	Measured (delta dB)
OC–12 SONET or STM–4 SDH, Data Rate: 622.08 Mb/s					
	0.0	–0.3	0.0	0.3	
	93.31	–0.41	–0.11	0.19	
	186.6	–0.75	–0.45	–0.15	
	279.9	–1.32	–1.02	–0.72	
	373.2	–2.16	–1.86	–1.56	
	466.7	–3.31	–3.00	–2.71	
	5.60.0	–5.15	–4.51	–3.87	
	622.08	–6.58	–5.71	–4.84	
	653.2	–7.35	–6.37	–5.39	
	746.5	–9.86	–8.54	–7.22	
	839.8	–12.59	–10.93	–9.27	
	933.1	–15.41	–13.41	–11.41	
	1244.2	–24.58	–21.44	–18.31	
OC–3 SONET or STM–1 SDH, Data Rate: 155.52 Mb/s					
	0.0	–0.3	–0.0	0.3	
	23.327	–0.41	–0.11	0.19	
	46.65	–0.75	–0.45	–0.15	
	69.975	–1.32	–1.02	–0.72	
	93.3	–2.16	–1.86	–1.56	
	116.88	–3.31	–3.00	–2.71	
	139.97	–5.15	–4.51	–3.87	
	155.52	–6.58	–5.71	–4.84	
	163.3	–7.35	–6.37	–5.39	
	209.95	–9.86	–8.54	–7.22	
	209.95	–12.59	–10.93	–9.27	
	233.27	–15.41	–13.41	–11.41	
	311.04	–24.58	–21.44	–18.31	

Table 1–11: Bessel Thompson frequency response and reference receiver limits (cont.)

Standard	Frequency (MHz)	Lower Limit (dB)	Nominal (dB)	Upper Limit (dB)	Measured (delta dB)
FC133 Fibre Channel, Data Rate: 132.8125 Mb/s					
	0.00	-0.5	0.0	0.5	
	19.922	-0.6	-0.1	0.4	
	38.440	-0.9	-0.4	-0.1	
	59.765	-1.5	-1.0	-0.5	
	79.690	-2.4	-1.9	-1.4	
	99.610	-3.5	-3.0	-2.5	
	119.53	-5.5	-4.5	-3.5	
	132.81	-7.03	-5.7	-4.37	
	139.45	-7.9	-6.4	-4.9	
	159.37	-10.5	-8.5	-6.5	
	179.29	-13.4	-10.9	-8.4	
	199.22	-16.4	-13.4	-10.4	
	265.62	-26.17	-21.5	-16.5	
FC266 Fibre Channel, Data Rate: 265.625 Mb/s					
	0.0	-0.5	0.0	0.5	
	39.844	-0.6	-0.1	0.4	
	79.688	-0.9	-0.4	-0.1	
	119.53	-1.5	-1.0	-0.5	
	159.38	-2.4	-1.9	-1.4	
	199.22	-3.5	-3.0	-2.5	
	239.06	-5.5	-4.5	-3.5	
	265.62	-7.03	-5.7	-4.37	
	278.91	-7.9	-6.4	-4.9	
	318.75	-10.5	-8.5	-6.5	
	358.59	-13.4	-10.9	-8.4	
	398.44	-16.4	-13.4	-10.4	
	531.25	-26.17	-21.5	-16.5	

Table 1–11: Bessel Thompson frequency response and reference receiver limits (cont.)

Standard	Frequency (MHz)	Lower Limit (dB)	Nominal (dB)	Upper Limit (dB)	Measured (delta dB)
FC531 Fibre Channel, Data Rate: 531.25 Mb/s					
	0.0	-0.5	-0.0	0.5	
	79.688	-0.6	-0.1	0.4	
	159.38	-0.9	-0.4	-0.1	
	239.06	-1.5	-1.0	-0.5	
	318.76	-2.4	-1.9	-1.4	
	398.44	-3.5	-3.0	-2.5	
	478.12	-5.5	-4.5	-3.5	
	531.24	-7.03	-5.7	-4.37	
	557.82	-7.9	-6.4	-4.9	
	637.50	-10.5	-8.5	-6.5	
	717.18	-13.4	-10.9	-8.4	
	796.88	-16.4	-13.4	-10.4	
	1062.5	-26.17	-21.5	-16.3	
FC1063 Fibre Channel (Controlled to 1.5X Data Rate), Data Rate: 1062.5 Mb/s					
	0.0	-0.5	0.0	0.5	
	159.38	-0.6	-0.1	0.4	
	318.75	-0.9	-0.4	0.1	
	478.12	-1.5	-1.0	-0.5	
	637.50	-2.4	-1.9	-1.4	
	796.87	-3.5	-3.0	-2.5	
	956.25	-5.5	-4.5	-3.5	
	1062.5	-7.03	-5.7	-4.37	
	1115.63	-7.9	-6.4	-4.9	
	1275.0	-10.5	-8.5	-6.5	
	1434.37	-13.4	-10.9	-8.4	
	1593.75	-16.4	-13.4	-10.4	



Specifications

Specifications

This section begins with a general description of the traits of the TDS 500D, TDS 600C, TDS 700D and TDS 714L oscilloscopes. Three sections follow, one for each of three classes of traits: *nominal traits*, *warranted characteristics*, and *typical characteristics*.

Product Description

The TDS 500D, TDS 600C, TDS 700D and TDS 714L oscilloscopes are portable, four-channel instruments suitable for use in a variety of test and measurement applications and systems. Table 2–1 lists key features.

Table 2–1: Key features of TDS 500D, 600C, 700D and 714L oscilloscopes

Feature	TDS 600C	TDS 500D, TDS 700D & TDS 714L
Digitizing rate, maximum	TDS 684C: 5 GS/s on ea. of 4 ch TDS 680C: 5 GS/s on ea. of 2 ch TDS 654C: 5 GS/s on ea. of 4 ch TDS 694C: 10 GS/s on ea. of 4 ch	TDS 580D, TDS 784D, TDS 794D: 4 GS/s TDS 540D, 754D: 2 GS/s TDS 520D, 724D: 1 GS/s TDS 714L: 500 MS/s
Analog bandwidth	TDS 694C: 3 GHz TDS 794D: 2 GHz TDS 580D, TDS 680C, 684C, and 784D: 1 GHz TDS 520D, 540D, 654C, 714L, 724D and 754D: 500 MHz	
No. of Channels	TDS 654C, 684C & 694C: 4 TDS 680C: 2 + 2 ¹	TDS 540D, 580D, TDS 714L, 754D, 784D & 794D: 4 TDS 520D & 724D: 2 + 2 ¹
Record lengths, maximum	15,000 samples TDS 694C: 30,000 samples (120,000 with option 1M)	50,000 (250,000 on TDS 714L) samples (500,000 with option 1M, not available on TDS 714L) (8,000,000 with option 2M)
Acquisition modes	Sample, envelope, peak detect and average	Sample, envelope, average, high-resolution, and peak-detect

Table 2–1: Key features of TDS 500D, 600C, 700D and 714L oscilloscopes (cont.)

Feature	TDS 600C	TDS 500D, TDS 700D & TDS 714L
Trigger modes	Modes include: Edge, logic, and pulse. Video trigger, with option 05, modes include: NTSC, SECAM, PAL, HDTV, and FlexFormat. (Not available on TDS 694C/794D) Communications Trigger with option 2C (not available on TDS 600C and TDS 714L), modes include: AMI, CMI, and NRZ	
Display	TDS 520D, 540D, 580D, 680C: Monochrome TDS 645C, 684C, 694C, 714L, 724D, 754D, 784D, 794D: Color	
Storage	Floppy disk drive: 1.44 Mbyte, 3.5 inch, DOS 3.3-or-later floppy disk drive Internal hard disk drive (optional) Iomega Zip drive compatible NVRAM storage for saving waveforms, hardcopies, and setups	
I/O	Full GPIB programmability. Hardcopy output using GPIB, RS-232, or Centronics ports	

¹ **Two plus Two channel operation allows up to two of the four channels to be displayed simultaneously. Channels not displayed can be used to couple a triggering signal to the oscilloscope.**

User Interface

Use a combination of front-panel buttons, knobs, and on-screen menus to control the many functions of the oscilloscope. The front-panel controls are grouped according to function: vertical, horizontal, trigger, and special. Set a function you adjust often, such as vertical positioning or the time base setting, directly by its own front-panel knob. Set a function you change less often, such as vertical coupling or horizontal mode, indirectly using a selected menu.

Menus Pressing one (sometimes two) front-panel button(s), such as vertical menu, displays a *main* menu of related functions, such as coupling and bandwidth, at the bottom of the screen. Pressing a main-menu button, such as coupling, displays a *side* menu of settings for that function, such as AC, DC, or GND (ground) coupling, at the right side of the screen. Pressing a side-menu button selects a setting such as DC.

Indicators On-screen readouts help you keep track of the settings for various functions, such as vertical and horizontal scale and trigger level. Some readouts use the cursors or the automatic parameter extraction feature (called measure) to display the results of measurements made or the status of the instrument.

General Purpose Knob Assign the general purpose knob to adjust a selected parameter function. More quickly change parameters by toggling the **SHIFT** button. Use the same method as for *selecting* a function, except the final side-menu selection assigns the general purpose knob to *adjust* some function, such as the position of measurement cursors on screen, or the setting for a channel fine gain.

GUI The user interface also makes use of a GUI, or Graphical User Interface, to make setting functions and interpreting the display more intuitive. Some menus and status are displayed using iconic representations of function settings, such as those shown here for full, 250 MHz and 20 MHz bandwidth. Such icons allow you to more readily determine status or the available settings.

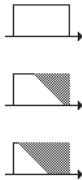

Signal Acquisition System

The signal acquisition system provides up to four, full-featured vertical channels with calibrated vertical scale factors from 1 mV to 10 V per division, depending on TDS model. All channels can be acquired simultaneously.

Each of the full-featured channels can be displayed, vertically positioned, and offset, and their vertical coupling specified. Some models can have their bandwidth limited (250 MHz or 20 MHz). Fine gain can also be adjusted.

Besides these channels, up to three math waveforms and four reference waveforms are available for display. (A math waveform results when you specify dual waveform operations, such as add, on any two channels. A reference waveform results when you save a waveform in a reference memory).

Horizontal System

There are three horizontal display modes: main only, main intensified, and delayed only. You can select among various horizontal record length settings.

A feature called “Fit to Screen” allows you to view entire waveform records within the 10 division screen area. Waveforms are compressed to fit on the screen. See Table 2–2.

Both the delayed only display and the intensified zone on the main intensified display may be delayed by time with respect to the main trigger. Both can be set to display immediately after the delay (delayed runs after main mode). The delayed display can also be set to display at the first valid trigger after the delay (delayed-triggerable modes).

The delayed display (or the intensified zone) may also be delayed by a selected number of events. In this case, the events source is the delayed-trigger source. The delayed trigger can also be set to occur after a number of events plus an amount of time.

Table 2–2: Record length and divisions per record versus TDS model

Standard Models	Record length	Divisions per record	
		FTS ¹ Off ²	FTS ¹ On ³
All TDS 500D, TDS600C, TDS 694C, TDS 700D, & TDS 714L, all channels ⁴	500	10 div	10 div
	1,000	20 div	10 div
	2,500	50 div	10 div
	5,000	100 div	10 div
	15,000	300 div	10 div
TDS 694C, all channels	30,000	600 div	15 div
TDS 500D, TDS 700D, & TDS 714L, all channels	50,000	1,000 div	15 div
Models with Option 1M ⁵	Record length	Divisions per record	
		FTS ¹ Off ²	FTS ¹ On ³
TDS 694C, all channels	50,000	1,000 div	10 div
TDS 500D, TDS 694C, TDS 700D, & TDS 714L, all channels	75,000	1,500 div	15 div
TDS 500D, TDS 694C, TDS 700D, & TDS 714L, all channels	100,000	2,000 div	12 div
TDS 694C, all channels	120,000	2,400 div	13 div
TDS 500D, TDS 700D, TDS 714L, all channels	130,000	2,600 div	10 div
TDS 520D, one channel only	250,000	5,000 div	10 div
TDS 540D, TDS 580D, all TDS 700D, & TDS 714L, one or two channels			
TDS 540D, TDS 580D, & all TDS 700D, one channel only	500,000	10,000 div	10 div

Table 2–2: Record length and divisions per record versus TDS model (cont.)

Models with Option 2M	Record length	Divisions per record	
		FTS ¹ Off ²	FTS ¹ On ³
TDS 520D & TDS 724D, one or two channels TDS 540D, TDS 580D, TDS 714L, TDS 754D, TDS 784D & TDS 794D, three or four channels	2,000,000	40,000 div	10 div
TDS 520D & TDS 724D, one channel only TDS 540D, TDS 580D, TDS 714L, TDS 754D, TDS 784D & TDS 794D, two channels	4,000,000	80,000 div	10 div
TDS 540D, TDS 714L, TDS 754D, TDS 784D & TDS 794D, one channel only	8,000,000	160,000 div	10 div

¹ **Fit to Screen setting**

² **Fit to Screen off preserves 50 samples/division in a 1–2–5 sec/division sequence.**

³ **Fit to Screen on lets the samples/division and the sec/division sequence vary.**

⁴ **All channels means all that may be displayed at one time: four channels for some models, two for others. See Table 2–1 and its footnote.**

⁵ **1M is the standard record length on the TDS 714L.**

Trigger System

The triggering system supports a varied set of features for triggering the signal-acquisition system. Trigger signals recognized include:

- **Edge (main- and delayed-trigger systems):** This familiar type of triggering is fully configurable for source, slope, coupling, mode (auto or normal), and holdoff.
- **Logic (main-trigger system):** This type of triggering can be based on pattern (asynchronous) or state (synchronous). In either case, logic triggering is configurable for sources, for Boolean operators to apply to those sources, for logic pattern or state on which to trigger, for mode (auto or normal), and for holdoff. Time qualification may be selected in pattern mode. Another class of logic trigger, setup/hold, triggers when data in one trigger source changes state within the setup and hold times that you specify relative to a clock in another trigger source.

- **Pulse (main-trigger system):** Pulse triggering is configurable for triggering on runt or glitch pulses, or on pulse widths or periods inside or outside limits that you specify. It can also trigger on a pulse edge that has a slew rate faster or slower than the rate you specify. The timeout trigger will act when events do *not* occur in a defined time period. The pulse trigger is also configurable for source, polarity, mode, and holdoff.
- **Video (with option 05: Video Trigger):** Video triggering is compatible with standard NTSC, PAL, SECAM, and HDTV formats. An additional feature called FlexFormat™ (flexible format) allows the user to define the video format on which to trigger.
- **Comm (with option 2C):** is provided for triggering on AMI, CMI, or NRZ communications signals.

You can choose where the trigger point is located within the acquired waveform record by selecting the amount of pretrigger data displayed. Presets of 10%, 50%, and 90% of pretrigger data can be selected in the horizontal menu, or the general purpose knob can be assigned to set pretrigger data to any value within the 0% to 100% limits.

Acquisition Control

You can specify a mode and manner to acquire and process signals that matches your measurement requirements.

- Select the mode for interpolation (linear or $\sin(x)/x$). This can increase the apparent sample rate on the waveform when the maximum real-time rate is exceeded.
- Use sample, envelope, average and peak detect modes to acquire signals. With the Oscilloscopes, also use high-resolution mode.
- Set the acquisition to stop after a single acquisition (or sequence of acquisitions if acquiring in average or envelope modes) or after a limit condition has been met.
- Select channel sources for compliance with limit tests. You can direct the TDS to signal you or generate hard copy output either to a printer or to a floppy-disk file based on the results. Also, you can create templates for use in limit tests.

On-Board User Assistance

Help and autoset can assist you in setting up the oscilloscope to make your measurements.

Help Help displays operational information about any front-panel control. When help mode is in effect, manipulating any front-panel control causes the oscilloscope to display information about that control. When help is first invoked, an introduction to help is displayed on screen.

Autoset Autoset automatically sets up the oscilloscope for a viewable display based on the input signal.

Measurement Assistance

Once you have set up to make your measurements, the cursor and measure features can help you quickly make those measurements.

Cursor Three types of cursors are provided for making parametric measurements on the displayed waveforms. Horizontal bar cursors (H Bar) measure vertical parameters (typically volts). Vertical bar cursors (V Bar) measure horizontal parameters (typically time or frequency). Paired cursors measure both amplitude and time simultaneously. These are delta measurements; that is, measurements based on the difference between two cursors.

Both H Bar and V Bar cursors can also be used to make absolute measurements. For the H Bars, either cursor can be selected to read out its voltage with respect to any channel's ground reference level. For the V Bars, the cursors measure time with respect to the trigger point (event) of the acquisition. The cursors can also control the portion of the waveform on which automatic measurements are made.

For time measurements, units can be either seconds or hertz (for 1/time).

With the video trigger option installed (Option 05), you can measure the video line number using the vertical cursors. You can measure IRE amplitude (NTSC) using the horizontal cursors with or without the video trigger option installed.

Measure Measure can automatically extract parameters from the signal input to the oscilloscope. Any four out of the 25 parameters available can be displayed to the screen. The waveform parameters are measured continuously with the results updated on-screen as the oscilloscope continues to acquire waveforms.

Digital Signal Processing (DSP)

An important component of the multiprocessor architecture of this oscilloscope is Tektronix' proprietary digital signal processor, the DSP. This dedicated processor supports advanced analysis of your waveforms when doing such compute-intensive tasks as interpolation, waveform math, and signal averaging. It also teams with a custom display system to deliver specialized display modes (See *Display*, later in this description).

Storage

Acquired waveforms may be saved in any of four nonvolatile REF (reference) memories or on a 3.5 inch, DOS 3.3-or-later compatible disk. Any or all of the saved waveforms may be displayed for comparison with the waveforms being currently acquired.

The Oscilloscopes instrument with option 2M can save waveforms to an internal hard disk drive. Any or all of the saved waveforms may be displayed for comparison with the waveforms being currently acquired.

The source and destination of waveforms to be saved may be chosen. You can save any of the four channels to any REF memory or move a stored reference from one REF memory to another. Reference waveforms may also be written into a REF memory location via the GPIB interface.

I/O

The oscilloscope is fully controllable and capable of sending and receiving waveforms over the GPIB interface (IEEE Std 488.1–1987/IEEE Std 488.2–1987 standard). This feature makes the instrument ideal for making automated measurements in a production or research and development environment that calls for repetitive data taking. Self-compensation and self-diagnostic features built into the oscilloscope to aid in fault detection and servicing are also accessible using commands sent from a GPIB controller.

The oscilloscope can also output copies of its display using the hardcopy feature. This feature allows you to output waveforms and other on-screen information to a variety of graphic printers and plotters from the TDS front panel, providing hard copies without requiring you to put the TDS into a system-controller environment.

You can make hardcopies in a variety of popular output formats, such as PCX, TIFF, BMP, RLE, EPS, Interleaf, and EPS mono or color. You can also save hardcopies in a disk file in any of the formats listed in the I/O section.

The hardcopies obtained are based on what is displayed on-screen at the time hardcopy is invoked. The hardcopies can be stamped with date and time and spooled to a queue for printing at a later time. You can output screen information via GPIB, RS-232-C, or Centronics interfaces.

Display

The TDS 500D, TDS 600C, TDS 700D and TDS 714L Oscilloscopes offer flexible display options. You can customize the following attributes of your display:

- Color (TDS 654C, TDS 684C, TDS694C, TDS 700D, and TDS 714L): Waveforms, readouts, graticule, and variable persistence with color coding
- Intensity: waveforms, readouts, and graticule
- Style of waveform display(s): vectors or dots, intensified or nonintensified samples, infinite persistence, and variable persistence
- Interpolation method: Sin(x)/x or Linear
- Display format: xy or yt with various graticule selections including NTSC and PAL to be used with video trigger (option 05)

This oscilloscope also provides an easy way to focus in on those waveform features you want to examine up close. By invoking zoom, you can magnify the waveform using the vertical and horizontal controls to expand (or contract) and position it for viewing.

Nominal Traits

Tables 2–3 through 2–9 list the various *nominal traits* that describe the TDS 500D, TDS 600C, TDS 700D and TDS 714L Oscilloscopes. Electrical and mechanical traits are included.

Nominal traits are described using simple statements of fact such as “Four, all identical” for the trait “Input Channels, Number of,” rather than in terms of limits that are performance requirements.

Table 2–3: Nominal traits — Signal acquisition system

Name	Description	
Bandwidth Selections	20 MHz, 250 MHz, and FULL (No BW limit on TDS 694C or TDS 794D)	
Samplers, Number of	TDS 540D, 580D, 654C, 684C, 694C, 714L, 754D, 784D, and 794D: Four, simultaneous TDS 520D, 680C, and 724D: Two, simultaneous	
Digitized Bits, Number of	8 bits ¹	
Input Channels, Number of	Four	
Input Coupling	DC, AC, or GND (TDS 694C/794D – DC or GND only)	
Input Impedance Selections	1 M Ω or 50 Ω (TDS 694C/794D – 50 Ω only)	
Ranges, Offset (All except TDS 694C/794D)	Volts/Div setting	Offset range
	1 mV/div – 100 mV/div	± 1 V
	101 mV/div – 1 V/div	± 10 V
	1.01 V/div – 10 V/div	± 100 V
Ranges, Offset (TDS 694C/794D only)	10 mV/div – 50 mV/div	± 0.50 V
	50.5 mV/div – 100 mV/div	± 0.25 V
	101 mV/div – 500 mV/div	± 5 V
	505 mV/div – 1 V/div	± 2.5 V
Range, Position	± 5 divisions	
Range, 1 M Ω Sensitivity ³	1 mV/div to 10 V/div ²	
Range, 50 Ω Sensitivity	1 mV/div to 1 V/div ² (10 mV/div – 1V/div on TDS 694C/794D)	

- ¹ Displayed vertically with 25 digitization levels (DLs) per division and 10.24 divisions dynamic range with zoom off. A DL is the smallest voltage level change of the oscilloscope input that can be resolved by the 8-bit A-D Converter. Expressed as a voltage, a DL is equal to 1/25 of a division times the volts/division setting.
- ² The sensitivity ranges from 1 mV/div to 10 V/div (for 1 M Ω) or to 1 V/div (for 50 Ω) in a 1–2–5 sequence of coarse settings with Fit-to-Screen off. Between coarse settings, the sensitivity can be finely adjusted with a resolution equal to 1% of the more sensitive coarse setting. For example, between 50 mV/div and 100 mV/div, the volts/division can be set with 0.5 mV resolution.
- ³ 1 M Ω not available on TDS 694C & TDS 794D oscilloscopes.

Table 2–4: Nominal traits — Time base system

Name	Description
Range, Sample-Rate ^{1,3}	<p>TDS 684C: 5 Samples/sec to 5 GSamples/sec on four channels simultaneously</p> <p>TDS 680C: 5 Samples/sec to 5 GSamples/sec on two channels simultaneously</p> <p>TDS 654C: 5 Samples/sec to 5 GSamples/sec on four channels simultaneously</p> <p>TDS 694C: 5 Samples/sec to 10 GSamples/sec on four channels simultaneously</p> <p>TDS 520D, and 724D: 5 Samples/sec to 2 GSamples/sec when acquiring 1 channel, to 1 GSample/sec when acquiring 2 channels</p> <p>TDS 540D: 5 Samples/sec to 2 GSamples/sec when acquiring 1 or 2 channels, to 1 GSample/sec when acquiring 3 or 4 channels</p> <p>TDS 540D Opt. 1G: 5 Samples/sec to 1 GSample/sec when acquiring 1 to 4 channels</p> <p>TDS 714L: 5 Samples/sec to 500 MSamples/sec when acquiring 1 to 4 channels</p> <p>TDS 754D: 5 Samples/sec to 2 GSamples/sec when acquiring 1 or 2 channels, to 1 GSample/sec when acquiring 3 or 4 channels</p> <p>TDS 754D Opt 1G: 5 Samples/sec to 1 GSample/sec when acquiring 1 to 4 channels</p> <p>TDS 580D, 784D, and 794D: 5 Samples/sec to 4 GSamples/sec when acquiring 1 channel, to 2 GSamples/sec when acquiring 2 channels, or to 1 GSample/sec when acquiring 3 or 4 channels</p>
Range, Interpolated Waveform Rate ^{2,3}	<p>TDS 600C: 10 GSamples/sec to 250 GSamples/sec</p> <p>TDS 694C: 10 GSamples/sec to 500 GSamples/sec</p> <p>TDS 520D, 540D, 714L, 724D, and 754D: 1 GSample/sec to 100 GSamples/sec</p> <p>TDS 580D, 784D, and 794D: 2 GSamples/sec to 250 GSamples/sec</p>
Range, Seconds/Division	<p>TDS 600C: 0.2 ns/div to 10 s/div</p> <p>TDS 694C: 0.1 ns/div to 10 s/div</p> <p>TDS 500D, 714L, 724D, and 754D: 0.5 ns/div to 10 s/div</p> <p>TDS 580D, 784D, and 794D: 0.2 ns/div to 10 s/div</p>

Table 2–4: Nominal traits — Time base system (cont.)

Name	Description
Record Length Selection	<p>TDS 500D, TDS 700D & TDS 714L: 500, 1,000, 2,500, 5,000, 15,000 and 50,000 samples</p> <p>TDS 714L: 1 or 2-channels: up to 250,000 samples 3 or 4-channels: up to 130,000 samples</p> <p>TDS 694C: 500, 1,000, 2,500, 5,000, 15,000 30,000 with option 1M: 50,000, 75,000, 100,000 and 120,000 samples all channels</p> <p>In addition to the record lengths previously listed, the following record lengths are available with the following options:</p> <p>TDS 520D & TDS 724D with option 1M: 1-channel: up to 250,000 samples 2-channels: up to 130,000 samples</p> <p>TDS 520D & TDS 724D with option 2M: 1-channel: up to 4,000,000 samples 2-channels: up to 2,000,000 samples</p> <p>TDS 540D, TDS 580D, TDS 754D, TDS 784D & TDS 794D with option 1M: 1-channel: up to 500,000 samples 2-channels: up to 250,000 samples 3 or 4-channels up to 130,000 samples</p> <p>TDS 540D, TDS 580D, TDS 714L, TDS 754D, TDS 784D & TDS 794D with option 2M: 1-channel: up to 8,000,000 samples 2-channels: up to 4,000,000 samples 3 or 4-channels up to 2,000,000 samples</p>

- ¹ The range of real-time rates, expressed in samples/second, at which a digitizer samples signals at its inputs and stores the samples in memory to produce a record of time-sequential samples.
- ² The range of waveform rates for interpolated (or equivalent-time on the TDS 700D) waveform records.
- ³ The Waveform Rate (WR) is the equivalent sample rate of a waveform record. For a waveform record acquired by real-time sampling of a single acquisition, the waveform rate is the same as the real-time sample rate; for a waveform created by interpolation of real-time samples from a single acquisition or, on applicable products, the equivalent-time sampling of multiple acquisitions, the waveform rate created is faster than the real time sample rate. For all these cases, the waveform rate is $1/(\text{Waveform Interval})$ for the waveform record, where the waveform interval (WI) is the time between the samples in the waveform record.

Table 2–5: Nominal traits — Triggering system

Name	Description
Range, Delayed Trigger Time Delay	16 ns to 250 s
Range, Events Delay	TDS 600C; 2 to 10,000,000 TDS 500D/700D/714L: 1 to 10,000,000

Table 2–5: Nominal traits — Triggering system (cont.)

Name	Description	
Range (Time) for Pulse-Glitch, Pulse-Width, Time-Qualified Runt, Timeout, or Slew Rate Trigger, Delta Time	1 ns to 1 s	
Ranges, Setup and Hold for TimeSetup/Hold Violation Trigger	Feature	Min to max
	Setup Time	–100 ns to 100 ns
	Hold Time	–1 ns to 100 ns –1 ns to 102 ns, TDS694C
	Setup + Hold Time	2 ns
	For Setup Time, positive numbers mean a data transition before the clock edge and negative means a transition after the clock edge.	
	For Hold Time, positive numbers mean a data transition after the clock edge and negative means a transition before the clock edge.	
	Setup + Hold Time is the algebraic sum of the Setup Time and the Hold Time programmed by the user.	
Ranges, Trigger Level or Threshold	Source	Range
	Any Channel	±12 divisions from center of screen
	Auxiliary	±8 V
	Line	±400 V
Video Trigger Modes of Operation (Option 05 Video Trigger, Not available on TDS 694C and TDS 794D)	<p>Supports the following video standards:</p> <ul style="list-style-type: none"> ■ NTSC (525/60) – 2 field mono or 4 field ■ PAL (625/50) – 2 field mono or SECAM, 8 field ■ HDTV – <ul style="list-style-type: none"> (787.5/60) (1050/60) (1125/60) (1250/60) ■ FlexFormat™ (user definable standards) <p>User can specify: field rate, number of lines, sync pulse width and polarity, line rate, and vertical interval timing.</p>	

Table 2-5: Nominal traits — Triggering system (cont.)

Name	Description		
Communication Trigger Modes of Operation (Option 2C Comm Trigger, Not available on TDS 600C and TDS 714L)	Standard Name	Code ¹	Bit Rate
	OC1/STM0	NRZ	51.84 Mb/s
	OC3/STM1	NRZ	155.52 Mb/s
	OC12/STM4	NRZ	622.08 Mb/s
	DS0 Sgl	Masks ²	64 kb/s
	DS0 Dbl	Masks ²	64 kb/s
	DS0 Data Contra	Masks ²	64 kb/s
	DS0 Timing	Masks ²	64 kb/s
	E1	AMI	2.048 Mb/s
	E2	AMI	8.44 Mb/s
	E3	AMI	34.368 Mb/s
	E4	CMI	139.26 Mb/s
	E5 (CEPT)	NRZ	565 Mb/s
	STM1E	CMI	155.52 Mb/s
	DS1	AMI	1.544 Mb/s
	DS1A	AMI	2.048 Mb/s
	DS1C	AMI	3.152 Mb/s
	DS2	AMI	6.312 Mb/s
	DS3/DS3 Rate	AMI	44.736 Mb/s
	DS4NA	CMI	139.26 Mb/s
	STS-1	AMI	51.84 Mb/s
	STS-3	CMI	155.52 Mb/s
	FC133	NRZ	132.8 Mb/s
	FC266	NRZ	265.6 Mb/s
	FC531	NRZ	531.2 Mb/s
	FC1063	NRZ	1.0625 Mb/s
	D2	NRZ	143.18 Mb/s
	D1	NRZ	270 Mb/s
	FDDI	NRZ	125 Mb/s
	4:2:2 SMPTE 259M-D	NRZ	360 Mb/s
10 Base-T	NRZ	10 Mb/s	
100 Base-T	NRZ	125 Mb/s	
Gigabit Ethernet	NRZ	1.25 Gb/s	

¹ AMI = Alternate Mark Inversion. CMI = Code Mark Inversion. NRZ = Non-return to Zero.

² These Telecom DS0 standards are automatically selected from the Mask Menu. The trigger uses Pulse/Width trigger.

Table 2-6: Nominal traits — Display system

Name	Description
Video Display	7 inch diagonal, with a display area of 5.04 inches horizontally by 3.78 inches vertically TDS 520D, 540D, 580D, and 680C: Monochrome display TDS 654C, 684C, 694C, 714L, 724D, 754D, 784D, and 794D: Color display
Video Display Resolution	640 pixels horizontally by 480 pixels vertically

Table 2–6: Nominal traits — Display system (cont.)

Name	Description
Waveform Display Graticule	Single Graticule: 401 × 501 pixels, 8 × 10 divisions, where divisions are 1 cm by 1 cm
Waveform Display Levels/Colors	TDS 520D, 540D, 580D, and 680C: Sixteen levels in infinite-persistence or variable persistence display TDS 654C, 684C, 694C, 714L, 724D, 754D, 784D, and 794D: Sixteen colors in infinite-persistence or variable persistence display

Table 2–7: Nominal traits — GPIB interface, output ports, and power fuse

Name	Description
Interface, GPIB	GPIB interface complies with IEEE Std 488-1987
Interface, RS-232	RS-232 interface complies with EIA/TIA 574 (talk only) Optional on the TDS 520D, 540D, 580D, and 680C
Interface, Centronics	Centronics interface complies with Centronics interface standard C332-44 Feb 1977, REV A Optional on the TDS 520D, 540D, 580D, and 680C
Interface, Video	VGA video output with levels that comply with EIA RS 343A standard. DB-15 connector
Logic Polarity for Main- and Delayed-Trigger Outputs	Negative TRUE. High to low transition indicates the trigger occurred.
Fuse Rating	Either of two fuses ¹ may be used: a 0.25" × 1.25" (UL 198.6, 3AG): 6 A FAST, 250 V or a 5 mm × 20 mm (IEC 127): 5 A (T), 250 V.
Fuse Rating TDS694C	Either of two fuses ¹ may be used: a 0.25" × 1.25" (UL 198.6, 3AG): 8 A FAST, 250 V or a 5 mm × 20 mm (IEC 127): 6.3 A (T), 250 V.

¹ Each fuse type requires its own fuse cap.

Table 2–8: Nominal traits — Data handling and reliability

Name	Description
Time, Data-Retention, Nonvolatile Memory ^{1, 2}	Battery life ≥ 5 years
Floppy disk drive	3.5 inch, 720 K or 1.44 Mbyte, DOS 3.3-or-later compatible
Internal hard disk drive (Option HD included in Option 2M)	2.1 Gbyte capacity
External data storage	lomega Zip drive compatible

¹ The times that reference waveforms, stored setups, and calibration constants are retained.

² Data is maintained by small lithium-thionyl-chloride batteries internal to the memory ICs. At the time of manufacture, no special disposal requirements were in effect for these batteries as the amount of hazardous material contained was below the regulated threshold. Consult your local waste disposal agency for proper disposal.

Table 2–9: Nominal traits — Mechanical

Name	Description
Cooling Method	Forced-air circulation with no air filter. Clearance is required. Refer to your user manual for minimum clearance dimensions.
Construction Material	Chassis parts constructed of aluminum alloy; front panel constructed of plastic laminate; circuit boards constructed of glass laminate. Cabinet is aluminum and is clad in Tektronix Blue vinyl material.
Weight	<p>Standard Oscilloscope</p> <p>14.1 kg (31 lbs), with front cover. 24.0 kg (53 lbs), when packaged for domestic shipment</p> <p>Rackmount Oscilloscopes</p> <p>14.1 kg (31 lbs) plus weight of rackmount parts, for the rackmounted Oscilloscopes (Option 1R).</p> <p>Rackmount conversion kit</p> <p>2.3 kg (5 lbs), parts only; 3.6 kg (8 lbs), parts plus package for domestic shipping</p>
Overall Dimensions	<p>Standard Oscilloscope</p> <p>Height: 193 mm (7.6 in), with the feet installed Width: 445 mm (17.5 in), with the handle Depth: 434 mm (17.1 in), with the front cover installed</p> <p>Rackmount Oscilloscope</p> <p>Height: 178 mm (7.0 in) Width: 483 mm (19.0 in) Depth: 558.8 mm (22.0 in)</p>

Warranted Characteristics

Tables 2–10 through 2–14 lists the various *warranted characteristics* that describe the TDS 500D, TDS 600C, TDS 700D and TDS 714L oscilloscopes. Electrical and environmental characteristics are included. Table 2–15 lists certifications and compliances.

Warranted characteristics are described in terms of quantifiable performance limits which are warranted.

NOTE. *In these tables, those warranted characteristics that are checked in the procedure Performance Verification appear in **boldface type** under the column Name.*

As stated above, this section lists only warranted characteristics. A list of *typical characteristics* starts on page 2–29.

The performance limits in this specification are valid with these conditions:

- The oscilloscope must have been calibrated/adjusted at an ambient temperature between +20° C and +30° C.
- The oscilloscope must be in an environment with temperature, altitude, humidity, and vibration within the operating limits described in these specifications.
- The oscilloscope must have had a warm-up period of at least 20 minutes.
- The oscilloscope must have had its signal-path-compensation routine last executed after at least a 20 minute warm-up period at an ambient temperature within $\pm 5^{\circ}$ C of the current ambient temperature.

Table 2–10: Warranted characteristics — Signal acquisition system

Name	Description		
Accuracy, DC Gain	<p>TDS 600C: $\pm 1.5\%$ for all sensitivities from 2 mV/div to 10 V/div $\pm 2.0\%$ at 1 mV/div sensitivity</p> <p>TDS 500D, 700D, 714L: $\pm 1\%$ for all sensitivities from 1 mV/div to 10 V/div with offset from 0 V to ± 100V</p> <p>TDS 694C/794D: $\pm 1\%$ for all sensitivities from 10 mV/div to 1 V/div over permitted offset range</p>		
Accuracy, DC Voltage Measurement, Averaged (using Average mode)	Measurement type	DC Accuracy	
	Average of ≥ 16 waveforms	<p>TDS 600C: $\pm((1.5\% \times \text{reading} - \text{Net Offset}^1) + \text{Offset Accuracy}) + (0.06 \text{ div} \times \text{V/div})$</p> <p>TDS 500D, TDS 694C, 700D, 714L: $\pm((1.0\% \times \text{reading} - \text{Net Offset}^1) + \text{Offset Accuracy} + (0.06 \text{ div} \times \text{V/div}))$</p>	
	Delta volts between any two averages of ≥ 16 waveforms acquired under the same setup and ambient conditions	<p>TDS 600C: $\pm((1.5\% \times \text{reading}) + (0.1 \text{ div} \times \text{V/div}) + 0.3 \text{ mV})$</p> <p>TDS 500D, TDS694C, 700D, 714L: $\pm((1.0\% \times \text{reading}) + (0.1 \text{ div} \times \text{V/div}) + 0.3 \text{ mV})$</p>	
Accuracy, Offset All except TDS 694C/794D	Volts/Div setting	TDS 600C Offset accuracy	TDS 500D/700D/714L Offset accuracy
	1 mV/div – 100 mV/div	$\pm((0.2\% \times \text{Net Offset}^1) + 1.5 \text{ mV} + (0.6 \text{ div} \times \text{V/div}))$	$\pm((0.2\% \times \text{Net Offset}^1) + 1.5 \text{ mV} + (0.1 \text{ div} \times \text{V/div}))$
	101 mV/div – 1 V/div	$\pm((0.25\% \times \text{Net Offset}^1) + 15 \text{ mV} + (0.6 \text{ div} \times \text{V/div}))$	$\pm((0.25\% \times \text{Net Offset}^1) + 15 \text{ mV} + (0.1 \text{ div} \times \text{V/div}))$
	1.01 V/div – 10 V/div	$\pm((0.25\% \times \text{Net Offset}^1) + 150 \text{ mV} + (0.6 \text{ div} \times \text{V/div}))$	$\pm((0.25\% \times \text{Net Offset}^1) + 150 \text{ mV} + (0.1 \text{ div} \times \text{V/div}))$
Accuracy, Offset TDS 694C and TDS 794D	Volts/Div setting	TDS 694C Offset accuracy	TDS 794D Offset accuracy
	10 mV/div – 100 mV/div	$\pm((0.2\% \times \text{Net Offset}^1) + 1.5 \text{ mV} + (0.1 \text{ div} \times \text{V/div}))$	$\pm((0.2\% \times \text{Net Offset}^1) + 1.5 \text{ mV} + (0.1 \text{ div} \times \text{V/div}))$
	101 mV/div – 1 V/div	$\pm((2.50\% \times \text{Net Offset}^1) + 15 \text{ mV} + (0.1 \text{ div} \times \text{V/div}))$	$\pm((0.25\% \times \text{Net Offset}^1) + 15 \text{ mV} + (0.1 \text{ div} \times \text{V/div}))$

Table 2–10: Warranted characteristics — Signal acquisition system (cont.)

Name	Description		
Analog Bandwidth, DC-50 Ω Coupled and Bandwidth selection is FULL, TDS 600C	Volts/Div	TDS 654C Bandwidth²	TDS 680C & 684C Bandwidth²
	10 mV/div – 1 V/div	DC – 500 MHz	DC – 1 GHz
	5 mV/div – 9.95 mV/div	DC – 450 MHz	DC – 750 MHz
	2 mV/div – 4.98 mV/div	DC – 300 MHz	DC – 600 MHz
	1 mV/div – 1.99 mV/div	DC – 250 MHz	DC – 500 MHz
	Volts/Div	TDS 694C Bandwidth²	
10 mV/div – 1 V/div	DC – 3 GHz		
Analog Bandwidth, DC-50 Ω Coupled and Bandwidth selection is FULL, TDS 500D/700D/714L	Volts/Div	TDS 520D, 540D, 714L, 724D & 754D Bandwidth²	TDS 580D & TDS 784D Bandwidth²
	10 mV/div – 1 V/div	DC – 500 MHz	DC – 1 GHz
	5 mV/div – 9.95 mV/div	DC – 500 MHz	DC – 750 MHz
	2 mV/div – 4.98 mV/div	DC – 500 MHz	DC – 600 MHz
	1 mV/div – 1.99 mV/div	DC – 450 MHz	DC – 500 MHz
	Volts/Div	TDS 794D Bandwidth²	
	10 mV/div – 1 V/div	DC – 2 GHz	
Crosstalk (Channel Isolation)	$\geq 100:1$ at 100 MHz and $\geq 30:1$ at the rated bandwidth for the channel's Volt/Div setting, for any two channels having equal Volts/Div settings. TDS 694C: $\geq 100:1$ at rated bandwidth for any two channels having equal Volts/Div settings.		
Delay Between Channels, Full Bandwidth	TDS 600C: ≤ 100 ps for any two channels with equal Volts/Div and Coupling settings and both channels' deskew values set to 0 TDS 500D, TDS 694C, TDS 700D, TDS 714L: ≤ 50 ps for any two channels with equal Volts/Div and Coupling settings and both channel deskew values set to 0.0 μ s.		
Input Impedance, DC-1 M Ω Coupled	1 M Ω $\pm 0.5\%$ in parallel with 10 pF ± 3 pF (DC-50 Ω Coupled only on TDS 694C/794D)		
Input Impedance, DC-50 Ω Coupled	50 Ω $\pm 1\%$ with VSWR $\leq 1.3:1$ from DC – 500 MHz, $\leq 1.5:1$ from 500 MHz – 1 GHz		
Input Impedance, DC-50 Ω Coupled TDS 694C	50 Ω $\pm 1.25\%$ with VSWR $\leq 1.5:1$ from 100 MHz – 1 GHz, VSWR $\leq 1.7:1$ from 1 GHz – 2 GHz, VSWR $\leq 2.0:1$ from 2 GHz – 3 GHz		
Input Impedance, DC-50 Ω Coupled TDS 794D	50 Ω $\pm 1.25\%$ with VSWR $\leq 1.5:1$ from 100 MHz – 1 GHz, VSWR $\leq 1.7:1$ from 1 GHz – 2 GHz		
Input Voltage, Maximum, DC-1 M Ω , AC-1 M Ω , or GND Coupled	TDS 600C (except TDS694C): ± 300 V CAT II, 400 V peak; derate at 20 dB/decade above 1 MHz TDS 500D/700D/714L (except TDS 794D): ± 300 V CAT II, 400 V peak; derate at 20 dB/decade above 1 MHz		

Table 2–10: Warranted characteristics — Signal acquisition system (cont.)

Name	Description
Input Voltage, Maximum, DC-50 Ω or AC-50 Ω Coupled	5 V _{RMS} , with peaks $\leq \pm 30$ V
<p>¹ Net Offset = Offset – (Position \times Volts/Div). Net Offset is the nominal voltage level at the oscilloscope input that corresponds to the center of the A-D converter's dynamic range. Offset Accuracy is the accuracy of this voltage level.</p> <p>² The limits given are for the ambient temperature range of 0°C to +30°C, range of 4°C to +30°C for a TDS694C. Reduce the upper bandwidth frequencies by 5 MHz for the TDS 600C, by 20 MHz for TDS 694C, by 2.5 MHz for the 500 MHz TDS 500D/700D/714L models, by 5 MHz for the 1 GHz TDS 500D/700D models, and by 10 MHz for the 2 GHz TDS 500D/700D models for each °C above +30°C.</p>	
Input Voltage, Maximum, DC-50 Ω Coupled TDS 694C/794D ?	5 V _{RMS} , with peaks $\leq \pm 20$ V
Lower Frequency Limit, AC Coupled	≤ 10 Hz when AC-1 M Ω Coupled; ≤ 200 kHz when AC-50 Ω Coupled ³
<p>³ The AC Coupled Lower Frequency Limits are reduced by a factor of 10 when 10X passive probes are used.</p>	

Table 2–11: Warranted characteristics — Time base system

Name	Description
Accuracy, Long Term Sample Rate and Delay Time	<p>TDS 600C: ± 100 ppm over any ≥ 1 ms interval</p> <p>TDS 694C: ± 10 ppm over any ≥ 1 ms interval</p> <p>TDS 500D/700D/714L: ± 25 ppm over any ≥ 1 ms interval</p>
Accuracy, Delta Time Measurement (Except for Option 1G and TDS 714L)	<p>The limits are given in the following table for signals having amplitude greater than 5 divisions, reference level = 50%, filter set to (sinX/X), acquired at 5 mV/div or greater. For the TDS 700D, pulse duration < 10 div. Channel skew not included.</p> <p>For the Single Shot condition, $1.4 \leq T_r \div S \leq 4$, where S is the sample rate and T_r is the displayed rise time.</p> <p>Extra error in the measurement will occur for two-channel measurements due to channel-to-channel skew. This is described elsewhere in these specifications.</p>
<p>Conditions for accuracy listed at right are: Single Shot or Sample mode (or HiRes mode on the TDS 500D/700D), with Full Bandwidth selected.</p>	<p>Time measurement accuracy</p>
	TDS 600C: $\pm((0.20 \div \text{sample rate}) + (100 \text{ ppm} \times \text{Reading}))$
	TDS 500D/700D: $\pm((0.15 \div \text{sample rate}) + (25 \text{ ppm} \times \text{Reading}))$
	TDS 694C: $\pm((0.15 \div \text{sample rate}) + (10 \text{ ppm} \times \text{Reading}))$
	<p>Example: at 5 GS/s, 5 ns/div, measuring a 40 ns wide pulse, accuracy = $\pm(40 \text{ ps} + 4 \text{ ps}) = \pm 44 \text{ ps}$.</p>

Table 2–12: Warranted characteristics — Triggering system

Name	Description		
Sensitivity, Edge-Type Trigger, Coupling set to “DC” ¹	Trigger source	Sensitivity	
	Any Channel	TDS 694C: 0.35 division from DC to 50 MHz, increasing to 1 division at 3 GHz main, 1.5 GHz delayed TDS 680C & 684C: 0.35 division from DC to 50 MHz, increasing to 1 division at 1 GHz TDS 500D, 714L, 724D, & 754D: 0.35 division from DC to 50 MHz, increasing to 1 division at 500 MHz TDS 580D & 784D: 0.35 division from DC to 50 MHz, increasing to 1 division at 1 GHz TDS 794D: 0.35 division from DC to 50 MHz, increasing to 1 division at 1.5 GHz	
	Auxiliary	TDS 600C: 250 mV from DC to 50 MHz, increasing to 500 mV at 100 MHz TDS 500D, 714L, 724D, & 754D: 400 mV from DC to 50 MHz, increasing to 750 mV at 100 MHz TDS 580D & 784D: 250 mV from DC to 50 MHz, increasing to 500 mV at 100 MHz TDS 794D: 250 mV from DC to 50 MHz, increasing to 500 mV at 100 MHz	
Width, Minimum Pulse and Rearm, for Pulse Triggering The minimum pulse widths and rearm widths and transition times ² required for Pulse-Type triggering.	For vertical settings > 10 mV/div. and ≤1 V/div at the BNC input		
	Pulse class	Minimum pulse width	Minimum re-arm width
	Glitch	1 ns	2 ns + 5% of Glitch Width Setting
	Runt	2 ns TDS 694C: 1 ns	2 ns
	Time-Qualified Runt	2 ns TDS 694C: 1 ns	TDS 694C & TDS 700D/714L: 8.5 ns + 5% of Width Setting
	Width	1 ns	2 ns + 5% of Width Upper Limit Setting
	Timeout	1 ns	2 ns + 5% of Width Upper Limit Setting
	Slew Rate	600 ps ²	TDS 694C & TDS 700D/714L: 8.5 ns + 5% of Delta Time Setting

Table 2–12: Warranted characteristics — Triggering system (Cont.)

Name	Description	
Accuracy (Time) for Pulse-Glitch or Pulse-Width Triggering	Time range	Accuracy
	2 ns to 500 ns	$\pm(20\% \text{ of setting} + 0.5 \text{ ns})$
	520 ns to 1 s	$\pm(100 \text{ ns} + 0.01\% \text{ of Setting})$
Input Signal Sync Amplitude for Stable Triggering, NTSC and PAL modes (Option 05 Video Trigger)	Field selection “Odd”, “Even”, or “All”: 0.6 division to 4 divisions Field selection “Numeric”: 1 division to 4 divisions (NTSC mode)	
Jitter (Option 05 Video Trigger)	60 ns _{p-p} on NTSC or PAL signal	

- ¹ The minimum sensitivity for obtaining a stable trigger. A stable trigger results in a uniform, regular display triggered on the selected slope. The trigger point must not switch between opposite slopes on the waveform, and the display must not “roll” across the screen on successive acquisitions. The TRIG'D LED stays constantly lighted when the SEC/DIV setting is 2 ms or faster but may flash when the SEC/DIV setting is 10 ms or slower.
- ² For Slew Rate Triggering, this is the minimum transition time, defined to be the time the user’s signal spends between the two trigger threshold settings.

Table 2–13: Warranted characteristics — Output ports, probe compensator, and power requirements

Name	Description	
Logic Levels, Main- and Delayed-Trigger Outputs	Characteristic	Limits
	Vout (HI)	$\geq 2.5 \text{ V}$ open circuit; $\geq 1.0 \text{ V}$ into a 50Ω load to ground
	Vout (LO)	$\leq 0.7 \text{ V}$ into a load of $\leq 4 \text{ mA}$; $\leq 0.25 \text{ V}$ into a 50Ω load to ground
Output Voltage and Frequency, Probe Compensator	Characteristic	Limits
	Output Voltage	0.5 V (base-top) $\pm 1\%$ into a $\geq 50 \Omega$ load
	Frequency	$1 \text{ kHz} \pm 5\%$
Output Voltage, Signal Out (CH 3 ¹) Not on TDS 694C	For TDS 600C: $20 \text{ mV/division} \pm 20\%$ into a $1 \text{ M}\Omega$ load; $10 \text{ mV/division} \pm 20\%$ into a 50Ω load For TDS 500D/700D/714L: $22 \text{ mV/division} \pm 20\%$ into a $1 \text{ M}\Omega$ load; $11 \text{ mV/division} \pm 20\%$ into a 50Ω load	
Source Voltage	100 to 240 VAC _{RMS} , continuous range, CAT II	
Source Frequency	45 Hz to 440 Hz	
Power Consumption TDS 694C	$\leq 350 \text{ W}$ (450 VA) $\leq 450 \text{ W}$ (500 VA)	

- ¹ CH 3 signal out is present at the rear panel if CH 3 (AUX 1 on the TDS 680C) is selected as the trigger source for the main and/or delayed trigger systems. It is not available when a channel other than CH3 (AUX 1 on the TDS 680C) is the source for the Video Trigger when Option 05 is installed.

Table 2–14: Warranted characteristics — Environmental

Name	Description
Atmospherics	<p>Temperature (no disk in floppy drive):</p> <p>TDS 600C: Operating: +4° C to +45° C</p> <p>TDS 694C: Operating: +4° C to +40° C</p> <p>Floppy disk drive: Operating: +10° C to +45° C Nonoperating: –22° C to +60° C</p> <p>TDS 500D/700D/714L: Operating: +0° C to +50° C</p> <p>Floppy disk drive: Operating: +10° C to +50° C Nonoperating: –22° C to +60° C</p> <p>Relative humidity (no disk in floppy drive):</p> <p>Operating: 20% to 80%, at or below +32° C, upper limit derates to 30% relative humidity at +45° C</p> <p>Operating: TDS 694C: 20% to 80%, at or below +32° C, upper limit derates to 30% relative humidity at +40° C</p> <p>Nonoperating: TDS 500D/700D/714L: 5% to 90%, at or below +31° C, upper limit derates to 20% relative humidity at 60° C</p> <p>TDS 600C: 5% to 90%, at or below +41° C, upper limit derates to 30% relative humidity at 60° C</p> <p>Altitude:</p> <p>To 4570 m (15,000 ft.), operating (excluding hard disk drive)</p> <p>To 3048 m (10,000 ft.), operating (including hard disk drive)</p> <p>To 12190 m (40,000 ft.), nonoperating</p>
Dynamics	<p>Random vibration (floppy disk not installed):</p> <p>0.31 g rms, from 5 to 500 Hz, 10 minutes each axis, operating</p> <p>2.46 g rms, from 5 to 500 Hz, 10 minutes each axis, nonoperating</p>

Table 2–14: Warranted characteristics — Environmental (cont.)

Name	Description
Approvals	Conforms to and is certified where appropriate to: UL 3111–1 ² – Standard for electrical measuring and test equipment CAN/CSA C22.2 no. 1010.1 ² – Safety requirements for electrical equipment for measurement, control and laboratory use

² **UL 3111, CSA 22.2 no.1010 Safety Certification Compliance:**
Temperature (operating) 5 to +40 C
Altitude (maximum operating): 2000 meters
Equipment Type: Test and Measurement
Safety Class: Class I (as defined in IEC 1010–1, Annex H) – grounded product
Overvoltage Category: Overvoltage Category II (as defined in IEC 1010–1, Annex J)
Pollution Degree: Pollution Degree 2 (as defined in IEC 1010–1)
Note – Rated for indoor use only

Table 2–15: Certifications and compliances

EC Declaration of Conformity — EMC ³ (TDS 500D, TDS 700D, and TDS 714L)	<p>Meets intent of Directive 89/336/EEC for Electromagnetic Compatibility. Compliance was demonstrated to the following specifications as listed in the Official Journal of the European Union:</p> <table border="0"> <tr> <td>EN 55011</td> <td>Class A Radiated and Conducted Emissions</td> </tr> <tr> <td>EN 50081-1 Emissions:</td> <td></td> </tr> <tr> <td> EN 60555-2</td> <td>AC Power Line Harmonic Emissions</td> </tr> <tr> <td>EN 50082-1 Immunity:</td> <td></td> </tr> <tr> <td> IEC 801-2</td> <td>Electrostatic Discharge Immunity</td> </tr> <tr> <td> IEC 801-3</td> <td>RF Electromagnetic Field Immunity</td> </tr> <tr> <td> IEC 801-4</td> <td>Electrical Fast Transient/Burst Immunity</td> </tr> <tr> <td> IEC 801-5</td> <td>AC Power Line Surge Immunity</td> </tr> </table>	EN 55011	Class A Radiated and Conducted Emissions	EN 50081-1 Emissions:		EN 60555-2	AC Power Line Harmonic Emissions	EN 50082-1 Immunity:		IEC 801-2	Electrostatic Discharge Immunity	IEC 801-3	RF Electromagnetic Field Immunity	IEC 801-4	Electrical Fast Transient/Burst Immunity	IEC 801-5	AC Power Line Surge Immunity				
EN 55011	Class A Radiated and Conducted Emissions																				
EN 50081-1 Emissions:																					
EN 60555-2	AC Power Line Harmonic Emissions																				
EN 50082-1 Immunity:																					
IEC 801-2	Electrostatic Discharge Immunity																				
IEC 801-3	RF Electromagnetic Field Immunity																				
IEC 801-4	Electrical Fast Transient/Burst Immunity																				
IEC 801-5	AC Power Line Surge Immunity																				
EC Declaration of Conformity — EMC ³ (TDS 600C)	<p>Meets intent of Directive 89/336/EEC for Electromagnetic Compatibility. Compliance was demonstrated to the following specifications as listed in the Official Journal of the European Union:</p> <table border="0"> <tr> <td>EN 55011</td> <td>Class A Radiated and Conducted Emissions</td> </tr> <tr> <td>IEC 61000-3-2</td> <td>AC Power Line Harmonic Emissions</td> </tr> <tr> <td>EN 50082-1 Immunity:</td> <td></td> </tr> <tr> <td> IEC 61000-4-2</td> <td>Electrostatic Discharge Immunity</td> </tr> <tr> <td> IEC 61000-4-3</td> <td>RF Electromagnetic Field Immunity</td> </tr> <tr> <td> IEC 61000-4-4</td> <td>Electrical Fast Transient/Burst Immunity</td> </tr> <tr> <td> IEC 61000-4-5</td> <td>AC Power Line Surge Immunity</td> </tr> <tr> <td> IEC 61000-4-6</td> <td>RF Conducted Immunity</td> </tr> <tr> <td> IEC 1000-4-8</td> <td>Magnetic Field Immunity</td> </tr> <tr> <td> IEC 1000-4-11</td> <td>AC Power Line Interruption Immunity</td> </tr> </table>	EN 55011	Class A Radiated and Conducted Emissions	IEC 61000-3-2	AC Power Line Harmonic Emissions	EN 50082-1 Immunity:		IEC 61000-4-2	Electrostatic Discharge Immunity	IEC 61000-4-3	RF Electromagnetic Field Immunity	IEC 61000-4-4	Electrical Fast Transient/Burst Immunity	IEC 61000-4-5	AC Power Line Surge Immunity	IEC 61000-4-6	RF Conducted Immunity	IEC 1000-4-8	Magnetic Field Immunity	IEC 1000-4-11	AC Power Line Interruption Immunity
EN 55011	Class A Radiated and Conducted Emissions																				
IEC 61000-3-2	AC Power Line Harmonic Emissions																				
EN 50082-1 Immunity:																					
IEC 61000-4-2	Electrostatic Discharge Immunity																				
IEC 61000-4-3	RF Electromagnetic Field Immunity																				
IEC 61000-4-4	Electrical Fast Transient/Burst Immunity																				
IEC 61000-4-5	AC Power Line Surge Immunity																				
IEC 61000-4-6	RF Conducted Immunity																				
IEC 1000-4-8	Magnetic Field Immunity																				
IEC 1000-4-11	AC Power Line Interruption Immunity																				
Australia/New Zealand Declaration of Conformity – EMC	<p>Complies with EMC provision of Radiocommunications Act per the following standard(s):</p> <table border="0"> <tr> <td>AS/NZS 2064.1/2</td> <td>Industrial, Scientific, and Medical Equipment: 1992</td> </tr> </table>	AS/NZS 2064.1/2	Industrial, Scientific, and Medical Equipment: 1992																		
AS/NZS 2064.1/2	Industrial, Scientific, and Medical Equipment: 1992																				
EC Declaration of Conformity – Low Voltage	<p>Compliance was demonstrated to the following specification as listed in the Official Journal of the European Communities:</p> <p>Low Voltage Directive 73/23/EEC, amended by 93/69/EEC</p> <table border="0"> <tr> <td>EN 61010-1/A2:1995</td> <td>Safety requirements for electrical equipment for measurement, control, and laboratory use</td> </tr> </table>	EN 61010-1/A2:1995	Safety requirements for electrical equipment for measurement, control, and laboratory use																		
EN 61010-1/A2:1995	Safety requirements for electrical equipment for measurement, control, and laboratory use																				

³ To ensure compliance with EMC requirements, only high quality shielded cables having a reliable, continuous outer shield with full coverage and low impedance connections to shielded connector housings at both ends should be connected to this product. The following cables, or their equivalent, may be used:

GPIB: Tektronix P/N 012–0991–00, –01, –02, or –03
RS–232: Computer Accessories P/N CA 0294–9
Centronics: Tektronix P/N 012–1214–00
VGA: LCOM P/N CTL3VGAMM–5 (if connected, terminate the cable)

Typical Characteristics

Tables 2–16 and 2–18 list the various *typical characteristics* which describe the TDS 500D, TDS 600C, TDS 700D and TDS 714L oscilloscopes.

Typical characteristics are described in terms of typical or average performance. Typical characteristics are not warranted.

Table 2–16: Typical characteristics — Signal acquisition system

Name	Description	
Analog Bandwidth, DC-50 Ω Coupled with P6243 or P6245 Probe and Bandwidth selection is FULL TDS 520D, 540D, 714L, 724D & 754D	Volts/Div as read out on screen	520D, 540D, 714L, 724D & 754D Bandwidth¹
	10 V/div – 100 V/div	Not Applicable
	100 mV/div – 10 V/div	DC – 500 MHz
	50 mV/div – 99.5 mV/div	DC – 500 MHz
	20 mV/div – 49.8 mV/div	DC – 500 MHz
Analog Bandwidth, DC-50 Ω Coupled with P6245 Probe and Bandwidth selection is FULL TDS 580D & TDS 784D	Volts/Div as read out on screen	TDS 580D & TDS 784D
	10 V/div – 100 V/div	(Not Applicable)
	100 mV/div – 10 V/div	DC – 1 GHz
	50 mV/div – 99.5 mV/div	DC – 750 MHz
	20 mV/div – 49.8 mV/div	DC – 600 MHz
Analog Bandwidth, DC-50 Ω Coupled with P6249 Probe TDS 694C	Volts/Div as read out on screen	TDS 694C¹
	100 mV/div – 10 V/div	DC – 3 GHz
Analog Bandwidth, DC-50 Ω Coupled with P6217 Probe TDS 794D	Volts/Div as read out on screen	TDS 794D
	100 mV/div – 10 V/div	DC – 2 GHz
Analog Bandwidth, DC-1 MΩ Coupled with P6139A Probe and Bandwidth selection is FULL TDS 520D, 540D, 580D, 714L, 724D, 754D & 784D	Volts/Div as read out on screen	TDS 520D, 540D, 714L, 724D, 754D & 784D Bandwidth¹
	10 V/div – 100 V/div	500 MHz
	100 mV/div – 10 V/div	500 MHz
	50 mV/div – 99.5 mV/div	500 MHz
	20 mV/div – 49.8 mV/div	500 MHz
10 mV/div – 19.9 mV/div	500 MHz	

Table 2–16: Typical characteristics — Signal acquisition system (cont.)

Name	Description		
Analog Bandwidth, DC-50 Ω Coupled with P6139A Probe (TDS 654C) or P6245 Probe (TDS 680C & 684C) and Bandwidth selection is FULL TDS 600C	Volts/Div as read out on screen	TDS 654C Bandwidth¹	TDS 680C & 684C Bandwidth¹
	10 V/div – 100 V/div	(Not Applicable)	(Not Applicable)
	100 mV/div – 10 V/div	DC – 500 MHz	DC – 1 GHz
	50 mV/div – 99.5 mV/div	DC – 450 MHz	DC – 750 MHz
	20 mV/div – 49.8 mV/div	DC – 300 MHz	DC – 600 MHz
10 mV/div – 19.9 mV/div	DC – 250 MHz	DC – 500 MHz	
Accuracy, Delta Time Measurement Conditions for accuracy listed at right are: ≥ 100 Averages, with Full Bandwidth selected, and for TDS 500D/700D/714L, repetitive mode.	The limits are given in the following table for signals having amplitude greater than 5 divisions, reference level = 50%, filter set to (sinX/X), acquired at 5 mV/div or greater. For the TDS 700D/714L, pulse duration < 10 division. Channel skew not included. TDS 600C: For the averaged condition, $1.4 \leq T_r/W_i \leq 40$, where W_i is the Waveform Interval, as described elsewhere in these specifications. Extra error in the measurement will occur for two-channel measurements due to channel-to-channel skew. This is described elsewhere in these specifications.		
	Time measurement accuracy		
	TDS 600C: $\pm(10 \text{ ps} + (100 \text{ ppm} \times \text{Reading}) + (0.2 \times W_i))$ TDS 500D/700D/714L: $\pm(20 \text{ ps} + (25 \text{ ppm} \times \text{Reading}) + (0.15 \times W_i))$ TDS 694C: $\pm(5 \text{ ps} + (10 \text{ ppm} \times \text{Reading}))$		
Calculated Rise Time, TDS 600C ² (except TDS 694C)	Volts/Div setting	TDS 654C Rise time	TDS 680C & 684C Rise time
	10 mV/div – 1 V/div	900 ps	450 ps
	5 mV/div – 9.95 mV/div	1 ns	600 ps
	2 mV/div – 4.98 mV/div	1.5 ns	750 ps
	1 mV/div – 1.99 mV/div	1.8 ns	900 ps
Calculated Rise Time, TDS 500D/700D/714L ²	Volts/Div setting	520D, 540D, 714L, 724D, & 754D Rise time	580D & 784D Rise time
	10 mV/div – 1 V/div	800 ps	400 ps
	5 mV/div – 9.95 mV/div	800 ps	530 ps
	2 mV/div – 4.98 mV/div	800 ps	600 ps
	1 mV/div – 1.99 mV/div	890 ps	800 ps
Calculated Rise Time, TDS 694C ²	Volts/Div setting	694C Rise time	
	10 mV/div – 1 V/div	133 ps	
Calculated Rise Time, TDS 794D ²	Volts/Div setting	794D Rise time	
	10 mV/div – 1 V/div	200 ps	

Table 2–16: Typical characteristics — Signal acquisition system (cont.)

Name	Description		
Effective Bits — TDS 694C The chart on the right gives the typical effective bits for a 9.2 divisions p-p sine wave input at 50 mV/div @ 25° C.	Input frequency		Sample rate
			10 GS/s
	1 MHz		6.6 bits
	1 GHz		5.5 bits
	2 GHz		4.5 bits
Effective Bits — TDS 600C (except TDS 694C) The chart on the right gives the typical effective bits for a 9-division p-p sine-wave input, 50 mV/div, 10 ns/div (5 GS/s), with a record length of 1000 points	Input frequency		Effective bits
	98 MHz		6.3 bits
	245 MHz		6.0 bits
	490 MHz		5.5 bits
	990 MHz		5.2 bits (TDS 680C & 684C only)
Effective Bits — TDS 520D & 724D The chart on the right gives the typical effective bits for a sine wave adjusted to 9.2 divisions at 1 MHz, 50 mV/div @ 25° C.	Input frequency		Sample rate
			1 GS/s
	1 MHz		6.8 bits
	490 MHz		6.5 bits
Effective Bits — TDS 540D & 754D The chart on the right gives the typical effective bits for a sine wave adjusted to 9.2 divisions at 1 MHz, 50 mV/div @ 25° C.	Input frequency		Sample rate
			2 GS/s
	1 MHz		6.8 bits
	500 MHz		6.8 bits
Effective Bits — TDS 714L The chart on the right gives the typical effective bits for a sine wave adjusted to 9.2 divisions at 1 MHz, 50 mV/div @ 25° C.	Input frequency		Sample rate
			500 MS/s
	1 MHz		6.8 bits
	500 MHz		6.8 bits
Effective Bits — TDS 580D, 784D & 794D The chart on the right gives the typical effective bits for a sine wave adjusted to 9.2 divisions at 1 MHz, 50 mV/div @ 25° C.	Input frequency		Sample rate
			4 GS/s
	1 MHz		6.6 bits
	1 GHz		5.5 bits
	2 GHz – 6.5 divs (TDS 794D only)		4.5 bits
Frequency Limit, Upper, 250 MHz Bandwidth Limited	250 MHz		
Frequency Limit, Upper, 20 MHz Bandwidth Limited	20 MHz		

Table 2–16: Typical characteristics — Signal acquisition system (cont.)

Name	Description		Settling error (%) ³ at		
			20 ns	100 ns	20 ms
Step Response Settling Errors	Volts/Div setting	± Step amplitude			
	1 mV/div – 100 mV/div	≤2 V	≤0.5%	≤0.2%	≤0.1%
	101 mV/div – 1 V/div	≤20 V	≤1.0%	≤0.5%	≤0.2%
	1.01 V/div – 10 V/div	≤200 V	≤1.0%	≤0.5%	≤0.2%
Step Response Settling Errors TDS 694C/794D	10 mV/div – 100 mV/div	≤1.5 V	≤0.5%	≤0.2%	≤0.1%
	101 mV/div – 1 V/div	≤3 V	≤1.0%	≤0.5%	≤0.2%

¹ The limits given are for the ambient temperature range of 0 °C to +30 °C, TDS 694C 4 °C to +30 °C. Reduce the upper bandwidth frequencies by 5 MHz for the TDS 600C or by 2.5 MHz for the TDS 500D/700D/714L for each °C above +30 °C. For the TDS 694C and TDS 794D reduce the upper bandwidth frequencies by 10 MHz for each °C above +30 °C.

² The numbers given are valid 0 °C to +30 °C and will increase as the temperature increases due to the degradation in bandwidth. Rise time is calculated from the bandwidth. It is defined by the following formula:

$$TDS\ 600C\ Rise\ Time\ (ns) = \frac{450}{BW\ (MHz)} \qquad TDS\ 500D/694C/700D\ Rise\ Time\ (ns) = \frac{400}{BW\ (MHz)}$$

Note that if you measure rise time, you must take into account the rise time of the test equipment (signal source, etc.) that you use to provide the test signal. That is, the measured rise time (RT_m) is determined by the instrument rise time (RT_i) and the rise time of the test signal source (RT_{gen}) according to the following formula:

$$RT_m^2 = RT_i^2 + RT_{gen}^2$$

³ The values given are the maximum absolute difference between the value at the end of a specified time interval after the midlevel crossing of the step and the value one second after the midlevel crossing of the step, expressed as a percentage of the step amplitude.

Table 2–17: Typical characteristics — Time base system

Name	Description
Accuracy, Delta Time Measurement (TDS 500D/700D Option 1G and TDS 714L)	The limits are given in the following table for signals having amplitude greater than 5 divisions, reference level = 50%, filter set to (sinX/X), acquired at 5 mV/div or greater. For the TDS 500D/700D Option 1G and the TDS 714L, pulse duration < 10 div. Channel skew not included.
Conditions for accuracy listed at right are: Single Shot, Sample or HiRes mode with Full Bandwidth selected.	For the Single Shot condition, $1.4 \leq T_r \div S \leq 4$, where S is the sample rate and T_r is the displayed rise time.
	Extra error in the measurement will occur for two-channel measurements due to channel-to-channel skew. This is described elsewhere in these specifications.
	Time measurement accuracy
	$\pm((0.15 \div \text{sample rate}) + (25\ \text{ppm} \times \text{Reading}))$

Table 2–18: Typical characteristics — Triggering system

Name	Description	
Accuracy, Trigger Level or Threshold, DC Coupled (for signals having rise and fall times ≥ 20 ns)	Trigger source	Accuracy
	Any Channel	$\pm((2\% \times \text{Setting} - \text{Net Offset}) + (0.3 \text{ div} \times \text{Volts/div Setting}) + \text{Offset Accuracy})$
	Auxiliary	Not calibrated or specified
Input, Auxiliary Trigger	The input resistance is $\geq 1.5 \text{ k}\Omega$; the maximum safe input voltage is $\pm 20 \text{ V}$ (DC + peak AC).	
Trigger Position Error, Edge Triggering	Acquisition mode	Trigger-position error^{1,2}
	Sample, Average	$\pm(1 \text{ Waveform Interval} + 1 \text{ ns})$
	Envelope	$\pm(2 \text{ Waveform Intervals} + 1 \text{ ns})$
Holdoff, Variable, Main Trigger	For all Time/Division ranges, the minimum holdoff is 250 ns and the maximum holdoff is 12 seconds. The minimum resolution is 8 ns for settings $\leq 1.2 \mu\text{s}$.	
Lowest Frequency for Successful Operation of “Set Level to 50%” Function	30 Hz TDS 694C: 50 Hz	
Trigger Jitter	TDS 580D, 680C, 684C, 784D, and 794D: $\sigma = 7 \text{ ps}$ TDS 520D, 540D, 654C, 694C, 714L, 724D, 754D: $\sigma = 8 \text{ ps}$ Provide a pulse with $T_{\text{rise}} \leq 350 \text{ ps}$ into one channel. Set the scope to 100 ps/div (250 GS/s TDS 580D, 680C, 684C, 784D, and 794D; 5 GS/s TDS 654C, 680C, 684C), with 6 div of signal, and the trigger level set to 50% of the rising edge. Turn on a horizontal histogram, with the box set to minimum height at the trigger point. Enable StdDev and Hits in Box histogram measurements. Wait for a least 1000 hits, then note the standard deviation of the trigger point.	
Sensitivity, Edge Trigger, Not DC Coupled ³	Trigger source	Typical signal level for stable triggering
	AC	Same as the DC-coupled limits for frequencies above 60 Hz. Attenuates signals below 60 Hz.
	Noise Reject	Three times the DC-coupled limits.
	High Frequency Reject	One and one-half times the DC-coupled limits from DC to 30 kHz. Attenuates signals above 30 kHz.
	Low Frequency Reject	One and one-half times the DC-coupled limits for frequencies above 80 kHz. Attenuates signals below 80 kHz.
Sensitivities, Logic Trigger and Events Delay, DC Coupled ⁴	1.0 division, from DC to 500 MHz, at vertical settings $> 10 \text{ mV/div}$ and $\leq 1 \text{ V/div}$ at the BNC input	
Sensitivities, Pulse-Type Runt Trigger ⁵	1.0 division, from DC to 500 MHz, at vertical settings $> 10 \text{ mV/div}$ and $\leq 1 \text{ V/div}$ at the BNC input	
Sensitivities, Pulse-Type Trigger Width and Glitch ⁶	1.0 division, at vertical settings $> 10 \text{ mV/div}$ and $\leq 1 \text{ V/div}$ at the BNC input	

Table 2–18: Typical characteristics — Triggering system (cont.)

Name	Description																					
Width, Minimum Pulse and Rearm, for Logic Triggering or Events Delay	For vertical settings > 10 mV/div and ≤ 1 V/div at the BNC input																					
	<table border="1"> <thead> <tr> <th>Triggering type</th> <th>Minimum pulse width</th> <th>Minimum re-arm width</th> <th>Minimum time between channels⁷</th> </tr> </thead> <tbody> <tr> <td>Logic</td> <td>Not Applicable</td> <td>1 ns</td> <td>1 ns</td> </tr> <tr> <td>Events Delay</td> <td>1 ns (for either + or – pulse widths)</td> <td>Not Applicable</td> <td>2 ns</td> </tr> </tbody> </table>	Triggering type	Minimum pulse width	Minimum re-arm width	Minimum time between channels ⁷	Logic	Not Applicable	1 ns	1 ns	Events Delay	1 ns (for either + or – pulse widths)	Not Applicable	2 ns									
	Triggering type	Minimum pulse width	Minimum re-arm width	Minimum time between channels ⁷																		
	Logic	Not Applicable	1 ns	1 ns																		
Events Delay	1 ns (for either + or – pulse widths)	Not Applicable	2 ns																			
Width, Minimum Pulse and Rearm, for Pulse Triggering The minimum pulse widths and rearm widths and transition times ⁸ required for Pulse-Type triggering.	For vertical settings > 10 mV/div. and 3 1 V/div at the BNC input																					
	<table border="1"> <thead> <tr> <th>Pulse class</th> <th>Minimum pulse width</th> <th>Minimum re-arm width</th> </tr> </thead> <tbody> <tr> <td>Glitch</td> <td>1 ns</td> <td>2 ns + 5% of Glitch Width Setting</td> </tr> <tr> <td>Runt</td> <td>2 ns</td> <td>2 ns</td> </tr> <tr> <td>Time-Qualified Runt</td> <td>2 ns TDS 694C: 1 ns</td> <td>TDS 500D/700D/714L: 8.5 ns + 5% of width setting TDS 600C: 7 ns + 5% of Width Setting TDS 694C: 8 ns + 5% of Width Setting</td> </tr> <tr> <td>Width</td> <td>1 ns</td> <td>2 ns + 5% of Width Upper Limit Setting</td> </tr> <tr> <td>Timeout</td> <td>1 ns</td> <td>2 ns + 5% of Width Upper Limit Setting</td> </tr> <tr> <td>Slew Rate</td> <td>600 ps⁸</td> <td>TDS 500D/700D/714L: 8.5 ns + 5% of delta time setting TDS 600C: 7 ns + 5% of Delta Time Setting</td> </tr> </tbody> </table>	Pulse class	Minimum pulse width	Minimum re-arm width	Glitch	1 ns	2 ns + 5% of Glitch Width Setting	Runt	2 ns	2 ns	Time-Qualified Runt	2 ns TDS 694C: 1 ns	TDS 500D/700D/714L: 8.5 ns + 5% of width setting TDS 600C: 7 ns + 5% of Width Setting TDS 694C: 8 ns + 5% of Width Setting	Width	1 ns	2 ns + 5% of Width Upper Limit Setting	Timeout	1 ns	2 ns + 5% of Width Upper Limit Setting	Slew Rate	600 ps ⁸	TDS 500D/700D/714L: 8.5 ns + 5% of delta time setting TDS 600C: 7 ns + 5% of Delta Time Setting
	Pulse class	Minimum pulse width	Minimum re-arm width																			
	Glitch	1 ns	2 ns + 5% of Glitch Width Setting																			
	Runt	2 ns	2 ns																			
	Time-Qualified Runt	2 ns TDS 694C: 1 ns	TDS 500D/700D/714L: 8.5 ns + 5% of width setting TDS 600C: 7 ns + 5% of Width Setting TDS 694C: 8 ns + 5% of Width Setting																			
	Width	1 ns	2 ns + 5% of Width Upper Limit Setting																			
	Timeout	1 ns	2 ns + 5% of Width Upper Limit Setting																			
Slew Rate	600 ps ⁸	TDS 500D/700D/714L: 8.5 ns + 5% of delta time setting TDS 600C: 7 ns + 5% of Delta Time Setting																				
Setup/Hold Time Violation Trigger, Minimum Clock Pulse Widths	For vertical settings > 10 mV/div and ≤ 1 V/div at the BNC input, the minimum requirements are:																					
	<table border="1"> <thead> <tr> <th>Minimum Pulse Width, Clock Active⁹</th> <th>Minimum Pulse Width, Clock Inactive⁹</th> </tr> </thead> <tbody> <tr> <td>User Hold Time + 2.5 ns¹⁰ User Hold Time + 2.6 ns¹⁰</td> <td>2 ns</td> </tr> </tbody> </table>	Minimum Pulse Width, Clock Active ⁹	Minimum Pulse Width, Clock Inactive ⁹	User Hold Time + 2.5 ns ¹⁰ User Hold Time + 2.6 ns ¹⁰	2 ns																	
	Minimum Pulse Width, Clock Active ⁹	Minimum Pulse Width, Clock Inactive ⁹																				
User Hold Time + 2.5 ns ¹⁰ User Hold Time + 2.6 ns ¹⁰	2 ns																					
Input Signal Sync Amplitude for Stable Triggering, HDTV and FLEXFMT modes (Option 05 Video Trigger)	All field selections: 0.6 division to 4 divisions																					
Jitter for HDTV mode (Option 05 Video Trigger)	17 ns _{p-p}																					
Sync Width Flex Format and HDTV modes (Option 05 Video Trigger)	min. 400 ns																					
Sync Duty Cycle, Flex Format and HDTV modes (Option 05 Video Trigger)	min. 50 to 1																					
Hum Rejection (Option 05 Video Trigger)	NTSC and PAL: –20 dB without any trigger spec deterioration. Triggering will continue down to 0 dB with some performance deterioration.																					

Table 2–18: Typical characteristics — Triggering system (cont.)

Name	Description
1	The trigger position errors are typically less than the values given here. These values are for triggering signals having a slew rate at the trigger point of ≥ 0.5 division/ns.
2	The waveform interval (WI) is the time between the samples in the waveform record. Also, see the footnote for the characteristics <i>Sample Rate Range or Interpolated Waveform Rates</i> in Table 2–4, on page 2–12.
3	The minimum sensitivity for obtaining a stable trigger. A stable trigger results in a uniform, regular display triggered on the selected slope. The trigger point must not switch between opposite slopes on the waveform, and the display must not “roll” across the screen on successive acquisitions. The TRIG'D LED stays constantly lighted when the SEC/DIV setting is 2 ms or faster but may flash when the SEC/DIV setting is 10 ms or slower.
4	The minimum signal levels required for stable logic or pulse triggering of an acquisition, or for stable counting of a DC-coupled, events-delay signal. Also, see the footnote for <i>Sensitivity, Edge-Type Trigger, DC Coupled</i> in this table. (Stable counting of events is counting that misses no events and produces no extra, phantom events).
5	The minimum signal levels required for stable runt pulse triggering of an acquisition. Also, see the footnote for <i>Sensitivity, Edge-Type Trigger, DC Coupled</i> in this table. (Stable counting of events is counting that misses no events).
6	The minimum signal levels required for stable pulse width or glitch triggering of an acquisition. Also, see the footnote for <i>Sensitivity, Edge-Type Trigger, DC Coupled</i> in this table. (Stable counting of events is counting that misses no events).
7	For Logic, time between channels refers to the length of time a logic state derived from more than one channel must exist to be recognized. For Events, the time is the minimum time between a main and delayed event that will be recognized if more than one channel is used.
8	For Slew Rate Triggering, this is the minimum transition time, defined to be the time the user’s signal spends between the two trigger threshold settings.
9	Active pulse width is the width of the clock pulse from its active edge (as defined in the Clock Edge selection in the Clock Source menu) to its inactive edge. Inactive pulse width is the width of the pulse from its inactive edge to its active edge.
10	User Hold Time is the number selected by the user in the Hold Time Menu.

