

Instruction Manual

Tektronix

**SignalScout™ RFM151
Cable TV RF Analyzer**

070-9960-01

This document supports firmware version 2.10 and above.

Warning

The servicing instructions are for use by qualified personnel only. To avoid personal injury, do not perform any servicing unless you are qualified to do so. Refer to all safety summaries prior to performing service.

CE

Copyright © Tektronix, Inc. All rights reserved.

Tektronix products are covered by U.S. and foreign patents, issued and pending. Information in this publication supercedes that in all previously published material. Specifications and price change privileges reserved.

Printed in the U.S.A.

Tektronix, Inc., P.O. Box 1000, Wilsonville, OR 97070-1000

TEKTRONIX and TEK are registered trademarks of Tektronix, Inc.

SignalScout is a trademark of Tektronix, Inc.



WARRANTY

Tektronix warrants that this product will be free from defects in materials and workmanship for a period of three (3) years from the date of shipment. If any such product proves defective during this warranty period, Tektronix, at its option, either will repair the defective product without charge for parts and labor, or will provide a replacement in exchange for the defective product.

In order to obtain service under this warranty, Customer must notify Tektronix of the defect before the expiration of the warranty period and make suitable arrangements for the performance of service. Customer shall be responsible for packaging and shipping the defective product to the service center designated by Tektronix, with shipping charges prepaid. Tektronix shall pay for the return of the product to Customer if the shipment is to a location within the country in which the Tektronix service center is located. Customer shall be responsible for paying all shipping charges, duties, taxes, and any other charges for products returned to any other locations.

This warranty shall not apply to any defect, failure or damage caused by improper use or improper or inadequate maintenance and care. Tektronix shall not be obligated to furnish service under this warranty a) to repair damage resulting from attempts by personnel other than Tektronix representatives to install, repair or service the product; b) to repair damage resulting from improper use or connection to incompatible equipment; c) to repair any damage or malfunction caused by the use of non-Tektronix supplies; or d) to service a product that has been modified or integrated with other products when the effect of such modification or integration increases the time or difficulty of servicing the product.

THIS WARRANTY IS GIVEN BY TEKTRONIX WITH RESPECT TO THIS PRODUCT IN LIEU OF ANY OTHER WARRANTIES, EXPRESSED OR IMPLIED. TEKTRONIX AND ITS VENDORS DISCLAIM ANY IMPLIED WARRANTIES OF MERCHANTABILITY OR FITNESS FOR A PARTICULAR PURPOSE. TEKTRONIX' RESPONSIBILITY TO REPAIR OR REPLACE DEFECTIVE PRODUCTS IS THE SOLE AND EXCLUSIVE REMEDY PROVIDED TO THE CUSTOMER FOR BREACH OF THIS WARRANTY. TEKTRONIX AND ITS VENDORS WILL NOT BE LIABLE FOR ANY INDIRECT, SPECIAL, INCIDENTAL, OR CONSEQUENTIAL DAMAGES IRRESPECTIVE OF WHETHER TEKTRONIX OR THE VENDOR HAS ADVANCE NOTICE OF THE POSSIBILITY OF SUCH DAMAGES.



Table of Contents

General Safety Summary	xi
Service Safety Summary	xiii
Preface	xv

Getting Started

Product Description	1-1
Rugged Construction	1-1
Compatibility	1-2
Level Measurement Modes	1-2
Other Operating Modes	1-3
User Interface	1-3
Automated Test Sequences	1-4
Results Storage	1-4
Printing	1-4
Accessories	1-5
Options	1-5

Operating Basics

Functional Overview	2-1
Connectors	2-1
Controls and Indicators	2-2
Battery	2-4
Explanation of Readouts	2-6
Tuning	2-8
Editing Methods	2-9
Menu Hierarchy	2-12

Reference

Measurement Reference	3-1
Common Measurement Characteristics	3-1
1 Channel Mode	3-3
5 Channel Mode	3-8
All Channel Mode	3-10
Carrier-to-Noise Ratio	3-15

Table of Contents

Desired to Undesired Mode	3-21
FM Deviation	3-25
Hum	3-27
Meter Mode	3-29
Pilots Mode	3-32
Relative Field Strength Mode	3-34
Spectrum Mode	3-38
Sweep Mode	3-58
Configuration Reference	3-63
Channel Tables	3-63
Clock	3-68
Clone Configuration	3-70
Display Adjustment	3-71
Executing Sequences	3-72
Help	3-75
Power Mode	3-77
Power Up / Power Down Modes	3-79
Powering Up From an AC Source	3-80
Presets	3-80
Printing	3-83
Probe Loss	3-85
Sequences (Adding and Deleting)	3-86
Site Name	3-88
Stored Measurement Results	3-90
Temperature	3-93
Units	3-94

Specifications

Specifications	4-1
----------------------	-----

Performance Check

Performance Check	5-1
Required Equipment	5-3
Signal Characterization	5-4
Performance Check Procedure	5-6
Front Panel / Backlight / Clock Operation Check	5-9
Communications Port Function Check	5-12

Maintenance

Replacement Procedures	6-1
Required Equipment	6-1
Instrument Disassembly	6-2
Replacing the Calibrated Board Set	6-4
Replacing the Charger/Battery Fuse	6-6
Replacing the Front Panel Circuit Board Assembly, Speaker, Encoder, or Keypads	6-9
Replacing the LCD Display Module	6-12
Replacing the Back Board Circuit Board Assembly	6-14
Replacing the Battery Interconnect Circuit Board Assembly	6-16
Instrument Assembly	6-19
Interior Cleaning	6-23

Replaceable Electrical Parts

Parts Ordering Information	7-1
Module Servicing	7-1
Using the Replaceable Parts List	7-2

Replaceable Mechanical Parts

Parts Ordering Information	8-1
Module Servicing	8-1
Using the Replaceable Parts List	8-2

Appendices

Appendix A: Channel Tables	A-1
CATV-Standard	A-2
CATV-500 Channels	A-8
Broadcast channels	A-11
CATV-HRC Channels	A-14
CATV-IRC Channels	A-18
China-DK Channels	A-22
Europe-BG Channels	A-24
Europe-DK Channels	A-27
Europe-I Channels	A-31
France-L Channels	A-33

Table of Contents

Japan-M Channels	A-36
Custom Channel Worksheet	A-39
Appendix B: Remote Communications	B-1
Communicating with Another RFM150/1	B-1
Communicating with a Computer (Using the SignalScout Application)	B-4
Communicating with a Printer	B-5
Printer Requirements	B-5
Setting the Printer Parameters	B-5
Hookup	B-6
Printing Stored Results	B-7
Appendix C: Battery	C-1
Appendix D: Exterior Cleaning	D-1

Index

List of Figures

Figure 2-1: Top view of the RF analyzer, showing connector locations	2-1
Figure 2-2: The SignalScout RFM151 RF analyzer front panel	2-2
Figure 2-3: Rechargeable NiCd battery pack	2-5
Figure 2-4: Display readouts and labels	2-6
Figure 2-5: Sample menu screen showing use of the outline cursor	2-9
Figure 2-6: Sample menu screen showing text editing	2-10
Figure 2-7: Menu hierarchy	2-12
Figure 3-1: The 1 channel mode (analog channel)	3-4
Figure 3-2: The 1 channel visual carrier difference measurement display	3-7
Figure 3-3: The 5 channel mode display	3-8
Figure 3-4: The all channel mode display	3-10
Figure 3-5: Carrier-to-noise measurement screen	3-16
Figure 3-6: First out-of-service C/N prompt	3-18
Figure 3-7: Second out-of-service C/N prompt	3-19
Figure 3-8: Completed out-of-service C/N measurement display	3-19
Figure 3-9: D/U measurement carrier off prompt	3-22
Figure 3-10: D/U measurement carrier on prompt	3-23
Figure 3-11: D/U measurement results	3-24

Table of Contents

Figure 3-12: The FM deviation measurement mode display	3-26
Figure 3-13: The hum measurement mode display	3-27
Figure 3-14: The meter mode display	3-30
Figure 3-15: The pilots mode display	3-32
Figure 3-16: The relative field strength mode display	3-34
Figure 3-17: The Spectrum mode display	3-39
Figure 3-18: Preamp, detection mode, and max hold indicators	3-42
Figure 3-19: Narrowed sweep window in spectrum mode	3-44
Figure 3-20: Demodulation spectrum display	3-47
Figure 3-21: Ingress monitor display	3-49
Figure 3-22: Ingress limits menu	3-50
Figure 3-23: Edit ingress limits menu display	3-51
Figure 3-24: Ingress monitor violations display	3-55
Figure 3-25: Stored ingress monitor waveform	3-56
Figure 3-26: The sweep display	3-58
Figure 3-27: The sweep LVL/REF submenu display	3-60
Figure 3-28: Reference menu	3-61
Figure 3-29: Channel tables menu	3-64
Figure 3-30: Editing channel tables	3-65
Figure 3-31: The Clock menu	3-69
Figure 3-32: Sequence menu	3-72
Figure 3-33: Execute sequence menu	3-73
Figure 3-34: The sleep state query screen	3-78
Figure 3-35: The power up / down menu	3-79

Figure 3-36: Assign preset menu	3-81
Figure 3-37: Editing Preset F1	3-82
Figure 3-38: Hardcopy in process	3-84
Figure 3-39: Sequence menu	3-86
Figure 3-40: Site name menu	3-88
Figure 3-41: Edit site name menu	3-89
Figure 3-42: Results menu	3-91
Figure 3-43: Additional information screen for 5 channel measurement type	3-92
Figure 3-44: Set Temperature menu	3-93
Figure 5-1: Hookup for 50 Ω source output	5-4
Figure 5-2: Alternate hookup for 50 Ω source output	5-4
Figure 5-3: Hookup for 75 Ω source output	5-5
Figure 5-4: Level menu function key assignments	5-9
Figure 5-5: Measurement menu function key assignments	5-9
Figure 5-6: Utility menu function key assignments	5-10
Figure 5-7: Store menu function key assignments	5-10
Figure 6-1: Separating the instrument into two parts	6-3
Figure 6-2: Removing the LCD Display module	6-5
Figure 6-3: Replacing the battery fuse	6-8
Figure 6-4: The front of the RF analyzer as seen from the inside	6-10
Figure 6-5: Removing the LCD Display module	6-13
Figure 6-6: Removing the Back Board circuit board assembly	6-14
Figure 6-7: Battery Interconnect circuit board	6-17
Figure 6-8: Positioning the ribbon cable	6-20
Figure 6-9: Installing the RF connector	6-21

Table of Contents

Figure 8-1: Exploded view, front case half	8-11
Figure 8-2: Exploded view, calibrated circuit board assembly and LCD display	8-12
Figure 8-3: Exploded view, rear case half	8-13
Figure B-1: RS232 menu showing factory settings	B-2
Figure B-2: Top view of SignalScout RF analyzer showing the RS-232 interface port	B-3
Figure B-3: UTIL function key assignments	B-5
Figure B-4: PRINTER menu showing factory settings	B-6
Figure C-1: Removing and replacing the NiCd battery pack	C-2

List of Tables

Table 3-1: Functions of active keys in 1 channel mode	3-3
Table 3-2: Custom channel table parameters	3-5
Table 3-3: Functions of active keys in 5 channel mode	3-8
Table 3-4: Functions of active keys in all channel mode ..	3-11
Table 3-5: Functions of active keys in C/N measurement mode	3-15
Table 3-6: Functions of active keys in D/U measurement mode	3-21
Table 3-7: Functions of active keys in FM deviation measurement mode	3-25
Table 3-8: Functions of active keys in hum measurement mode	3-28
Table 3-9: Functions of active keys in meter mode	3-29
Table 3-10: Functions of active keys in pilots mode	3-32
Table 3-11: Functions of active keys in relative field strength mode	3-35
Table 3-12: Functions of active keys in spectrum mode	3-39
Table 3-13: Span/division and resolution bandwidth	3-41
Table 3-14: Ingress monitor mode parameters	3-54
Table 3-15: Functions of active keys in sweep display mode	3-58
Table 3-16: Channel table fields for editing	3-65
Table 3-17: POWER key modes	3-77
Table 4-1: Electrical specifications	4-1
Table 4-2: AC power source characteristics	4-7
Table 4-3: DC power characteristics	4-8
Table 4-4: Battery characteristics6	4-8

Table of Contents

Table 4-5: Certifications and compliances	4-9
Table 4-6: Environmental characteristics	4-10
Table 4-7: Physical characteristics	4-11
Table 5-1: Test record for the RF analyzer	5-2
Table A-1: CATV-Standard	A-2
Table A-2: CATV-500 Standard	A-8
Table A-3: Broadcast channels	A-11
Table A-4: CATV-HRC channels	A-14
Table A-5: CATV-IRC channels	A-18
Table A-6: China-DK channels	A-22
Table A-7: Europe-BG channels	A-24
Table A-8: Europe-DK channels	A-27
Table A-9: Europe-I channels	A-31
Table A-10: France-L channels	A-33
Table A-11: Japan-M channels	A-36
Table A-12: Custom Channel worksheet	A-39
Table B-1: Pin assignments for interface port	B-2

General Safety Summary

Review the following safety precautions to avoid injury and prevent damage to this product or any products connected to it. To avoid potential hazards, use this product only as specified.

Only qualified personnel should perform service procedures.

To Avoid Fire or Personal Injury

Use Proper Power Cord. Use only the power cord specified for this product and certified for the country of use.

Replace Batteries Properly. Replace batteries only with the proper type and rating specified.

Recharge Batteries Properly. Recharge batteries for the recommended charge cycle only.

Use Proper AC Adapter. Use only the AC adapter specified for this product.

Do Not Operate Without Covers. Do not operate this product with covers or panels removed.

Use Proper Fuse. Use only the fuse type and rating specified for this product.

Avoid Exposed Circuitry. Do not touch exposed connections and components when power is present.

Do Not Operate With Suspected Failures. If you suspect there is damage to this product, have it inspected by qualified service personnel.

Do Not Operate in an Explosive Atmosphere.

Safety Terms and Symbols

Terms in This Manual. These terms may appear in this manual:



WARNING. Warning statements identify conditions or practices that could result in injury or loss of life.

General Safety Summary



CAUTION. Caution statements identify conditions or practices that could result in damage to this product or other property.

Terms on the Product. These terms may appear on the product:

DANGER indicates an injury hazard immediately accessible as you read the marking.

WARNING indicates an injury hazard not immediately accessible as you read the marking.

CAUTION indicates a hazard to property including the product.

Symbols on the Product. These symbols may appear on the product:



CAUTION
Refer to Manual



Double
Insulated

Battery Recycling

This product contains a Nickel Cadmium (NiCd) battery, which must be recycled or disposed of properly. For the location of a local battery recycler in the U.S. or Canada, please contact:

RBRC
Rechargeable Battery Recycling Corp.
P.O. Box 141870
Gainesville, Florida 32614

(800) BATTERY
(800) 227-7379
www.rbrc.com



Service Safety Summary

Only qualified personnel should perform service procedures. Read this *Service Safety Summary* and the *General Safety Summary* before performing any service procedures.

Do Not Service Alone. Do not perform internal service or adjustments of this product unless another person capable of rendering first aid and resuscitation is present.

Disconnect Power. To avoid electric shock, disconnect the main power by means of the power cord and power switch.

Disconnect RF Signal. Opening the SignalScout RFM151 Cable TV RF Analyzer case while an RF signal is applied can expose the operator to hazardous voltages. Always disconnect the RF INPUT connector from the RF analyzer before opening the case.

To avoid electric shock, do not touch exposed connections.

Safety Summary



Preface

This manual provides operating and service information for the SignalScout RFM151 Cable TV RF Analyzer. Information following the Service Safety Warning page is for qualified service technicians only. Operators should be familiar with basic television terms and measurements, and qualified service technicians should have moderate experience repairing analog and logic circuits.

Manual Organization

The manual provides the information indicated in the following sections:

Getting Started. Describes the SignalScout RFM151 RF analyzer and the instrument options and accessories.

Operating Basics. Describes controls and connectors, basic operating information, and a menu map.

Reference. Provides detailed discussions of SignalScout RFM151 RF analyzer measurements and operating information in alphabetical order by topic.

Specifications. Provides electrical and mechanical specifications.

Service Safety Warning. Represents the beginning of the service part of the manual.

Performance Check. Provides performance check procedure with a form for recording data.

Maintenance. Provides procedures for calibrated board set replacement and internal instrument cleaning.

Replaceable Electrical Parts Lists. Lists the module-level replaceable electrical parts.

Replaceable Mechanical Parts Lists. Provides an exploded-view diagram and a list of replaceable mechanical parts.

Appendix A. Provides channel table information.

Preface

Appendix B. Provides remote communication information.

Appendix C. Provides procedures for replacing and recharging the NiCd battery pack.

Index. Provides an alphabetical index of topics

Documentation Conventions

The word *press* is used when referring to a front-panel key, and *select* is used when referring to an on-screen label.

The names and labels of front-panel keys and selections available on-screen are shown in uppercase letters when used in procedures, but are spelled out using lowercase letters in general discussions. For example, “Press SEQ,” but “The sequence menu is used to activate measurement routines.”

Contacting Tektronix

Product Support For application-oriented questions about a Tektronix measurement product, call toll free in North America:
1-800-TEK-WIDE (1-800-835-9433 ext. 2400)
6:00 a.m. – 5:00 p.m. Pacific time

Or contact us by e-mail:
tm_app_supp@tek.com

For product support outside of North America, contact your local Tektronix distributor or sales office.

Service Support Contact your local Tektronix distributor or sales office. Or visit our web site for a listing of worldwide service locations.

<http://www.tek.com>

For other information In North America:
1-800-TEK-WIDE (1-800-835-9433)
An operator will direct your call.

To write us Tektronix, Inc.
P.O. Box 1000
Wilsonville, OR 97070-1000

Preface

Product Description

The SignalScout RFM151 Cable TV RF Analyzer is a high-performance RF signal meter designed for cable television applications. It provides signal level measurement capabilities and other features necessary to install and maintain a cable television system. In addition to signal level measurements, the RF analyzer provides carrier-to-noise, hum, FM deviation, desired-to-undesired, and field strength measurements, as well as three different spectral displays, and AM and FM demodulation modes.

Rugged Construction

The rugged mechanical construction, high-impact material, and internal shock system provide excellent resistance to damage. Weather-resistant construction ensures operation in varying weather conditions. The padded carrying case protects the RF analyzer during transit.

The SignalScout RFM151 RF analyzer is designed to resist the effects of rain and moisture. This weather-resistant construction allows the instrument to operate without hazard to you under conditions of moderately inclement weather.

Compatibility

The RF analyzer is designed to be compatible with NTSC, PAL, and SECAM cable television systems. Channel tables for most countries are built in, and you can load additional tables from a computer (using the companion SignalScout CSS151 software) or from another RF analyzer.

The RF analyzer can measure the levels of dual-carrier sound systems, including NICAM, analog dual carrier, and Korean dual carrier. It can also measure the average power level of digitally modulated carriers.

Level Measurement Modes

The SignalScout RFM151 RF analyzer supports the following measurement modes.

1 Channel Mode. For analog channels, this mode displays visual carrier level (in dBmV or dBuV), aural carrier difference (in dBc) measurements. For digital channels, digital average power (in dBmV or dBuV) and, in hybrid systems, digital to analog carrier difference (in dBc) measurements are displayed.

Pilots Mode. This mode simultaneously displays the levels of two channels.

5 Channel Mode. This mode simultaneously displays the levels of five channels.

All Channel Mode. This mode provides a graphic display of the carrier levels of all the channels defined in the selected channel table.

Meter Mode. This is a general purpose level measurement mode which you can use for peaking and/or nulling adjustments. The results are displayed on a simulated analog meter. In this mode, when the instrument is tuned to an aural carrier both AM and FM signals can be demodulated.

Other Operating Modes

In addition to the level measurement modes, the following modes are available:

Measure. This mode measures carrier-to-noise, hum, FM deviation, desired-to-undesired, and relative field strength measurements.

Spectrum. This mode provides three spectrum modes: General, Demodulation, and Ingress. Using these three modes you can quickly sweep the the selected band, demodulate both AM and FM signals at the marker, and monitor the return path spectrum for ingress violations. Used jointly with the relative field strength measurements, Ingress Monitor mode allows you to identify sources of ingress that disrupt transmission at return path frequencies.

Sweep. This mode makes reference sweeps. First, measure the carrier levels of a point upstream and store the results as a reference. Then you can measure the response of a point downstream relative to the reference.

Help. This mode provides context-sensitive help. Use the knob to scroll through the various help screens.

User Interface

By pressing a menu key, you display choices that you select from using function keys (F1–F5), the knob, or the numeric keypad. You can tune the instrument by selecting a preset channel that you have defined. You can also tune by channel or frequency using the knob or numeric keypad.

Automated Test Sequences

Two different 24 hour test sequences are already loaded in the RF analyzer. You can load additional test sequences from a PC (using the companion SignalScout CSS151 software), or from another SignalScout RFM151 RF analyzer via the RS-232 interface. You can set these test sequences to begin immediately, or to begin at a programmed time. The instrument will turn itself on, perform the sequence of measurements, then turn itself off to extend battery life.

Results Storage

You can store individual measurement results and test sequence results in the non-volatile memory. Time, date, temperature, and site identification are included with each record. You can also send measurement results to a PC for long-term storage of maintenance records.

Printing

You can print any screen displayed by the SignalScout RFM151 RF analyzer, except the help screens, using the RS232 interface. Press and hold the ESC key until the instrument beeps (about three seconds), and the display is sent to the selected printer for a hard copy.

Accessories

The following standard accessories are shipped with the SignalScout RFM151 Cable TV RF Analyzer:

- Manual, Instruction: (this manual) (070-9960-01)
- Reference card, laminated (061-4121-00)
- Carrying case, padded, with shoulder strap (016-1642-00)
- 120 VAC power pack (119-4855-00)
- RS-232-C DC-9 female-female cable assembly (174-3269-00)
- Precision female-female type F adapter (103-0301-00)
- Cigarette lighter adapter (119-4860-00)
- SignalScout CSS151 software with manual (070-9959-00)

The following optional accessories can also be ordered:

- Adapter, BNC to F Series (103-0310-00)
- Strand hook adapter (RFMSHA)
- Additional batteries (RFMBAT)
- Battery charger (RFMCHG)
- Flexible, helical antenna (RFMANT)
- TEK HC411 battery powered printer with manual (HC411)

Options

Order the RF analyzer with the following options:

Power Plug Options

- Option A1: Universal Euro 220 VAC Power Pack (119-4856-00)
- Option A2: UK 220 VAC Power Pack (119-4857-00)
- Option A3: Australian 220 VAC Power Pack (119-4858-00)
- Option A6: Japan 100 VAC Power Pack (119-4859-00)

Product Description

Functional Overview

This section provides you with an overview of the connectors, instrument controls, and use of the SignalScout RFM151 Cable TV RF Analyzer. A tutorial, which provides a more in-depth introduction to the measurements and capabilities of the instrument, follows this section.

Connectors

See Figure 2-1 for connector locations.

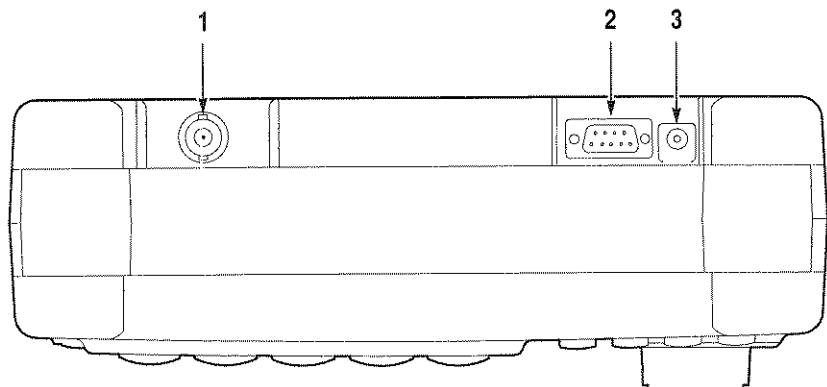

Figure 2-1: Top view of the RF analyzer, showing connector locations

1. The RF input is a precision 75 Ω F connector with a replaceable F-style or BNC-style adapter.
2. The interface port has a 9-pin, subminiature D-type connector that provides a serial interface for remote control. Pin connections are listed in Appendix B.

3. The DC jack input is a 2.5 mm plug that allows recharging of the internal NiCd battery pack and operation of the instrument with an external AC/DC adapter. If AC power is connected, and the instrument is turned off or in sleep mode, the battery is charging. Use only the Tektronix adapter supplied with this product. (See *Battery* in the *Maintenance* section beginning on page 0-1 for more information about recharging the battery pack.)

Controls and Indicators

This section provides a general description of each control's function. See Figure 2-2 for control locations.

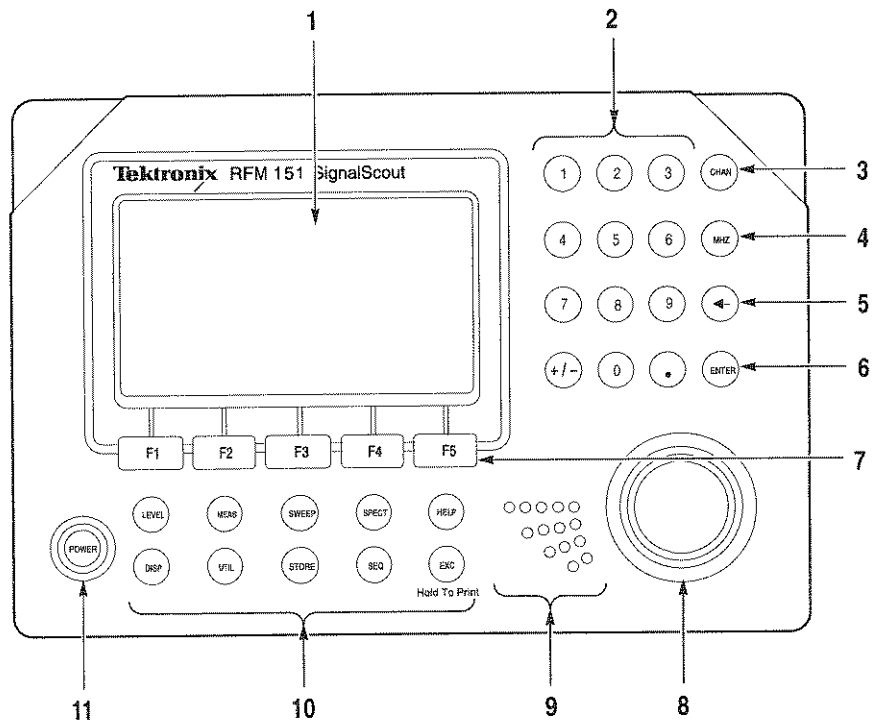

Figure 2-2: The SignalScout RFM151 RF analyzer front panel

1. The LCD display provides graphic and numeric readouts for selected measurement and menu modes. The display readouts are described on page 2–6. To adjust the display for best viewing, see page 3–71.
2. Use the numeric keypad to enter a channel number or frequency value. Terminate such an entry with CHAN, MHz, or ENTER. You can also use the keypad to enter numbers in alphanumeric text strings.
3. CHAN switches the instrument to channel entry mode. If CHAN is used to terminate a keypad entry, it will switch the instrument to the channel entry mode and tune the instrument to the keyed channel.
4. MHz switches the instrument to frequency entry mode. If MHz is used to terminate a keypad entry, it will switch the instrument to frequency entry mode and tune the instrument to the keyed frequency.
5. The backspace key (←) will erase the character preceding the cursor during a keypad entry. A pending keypad entry can be aborted by back spacing 1 click beyond an empty entry.
6. ENTER is used to terminate a keypad entry in channel or frequency mode.
7. Keys F1 through F5 are referred to as function keys or soft keys because their functions vary, based on the instrument operating mode. In this manual, they are also referred to as F keys. Key assignments are displayed along the bottom of the LCD screen. Pressing one of the function keys will stop a keypad entry in progress.
8. The knob function varies, based on the selected instrument mode. Knob functions include channel tuning, frequency tuning, speaker volume, reference level, and span. In some modes, the knob chooses among several items displayed on screen. In modes that allow text string entry, the knob selects letters from a displayed alphabet. ENTER must be pressed after each letter. The knob overrides a partial keypad entry.

9. In meter and demodulation spectrum modes, the speaker is used to monitor AM and FM audio. To control the speaker volume in either mode, select the function key assigned to KNOB VOL and turn the knob. The speaker also provides a warning for error conditions, can be used as an alarm indicator in the ingress spectrum monitor mode, and provides an audible indicator of signal strength.
10. There are 10 menu keys, which provide access to on-screen menus and submenus. Selecting any menu key will stop a keypad entry in progress.

NOTE. *To ensure proper operation under all conditions, always plug the AC adapter into the RF analyzer before connecting to the AC power source.*

11. POWER turns the instrument power on and off. Information about what pressing the power switch does in different situations is provided in the *Configuration Reference* section on page 3-77.
12. ESC exits the current menu and reassigns the function keys to that of the previous screen or cancels a partial keypad entry. Pressing the ESC key and holding it until the instrument beeps, sends the current measurement display to a connected printer.

Battery

The RF analyzer has a user accessible, rechargeable nickel-cadmium (NiCd) battery. Access to the battery is provided at the back of the instrument. See Figure 2-3. Procedures for removing and recharging the battery pack are provided in *Appendix C: Battery*.

NOTE. *Nickel-cadmium (NiCd) batteries are a hazardous substance and must be disposed of properly. See Battery Recycling in the General Safety Summary on page xii for instructions on how to properly dispose of the used batteries for this instrument.*

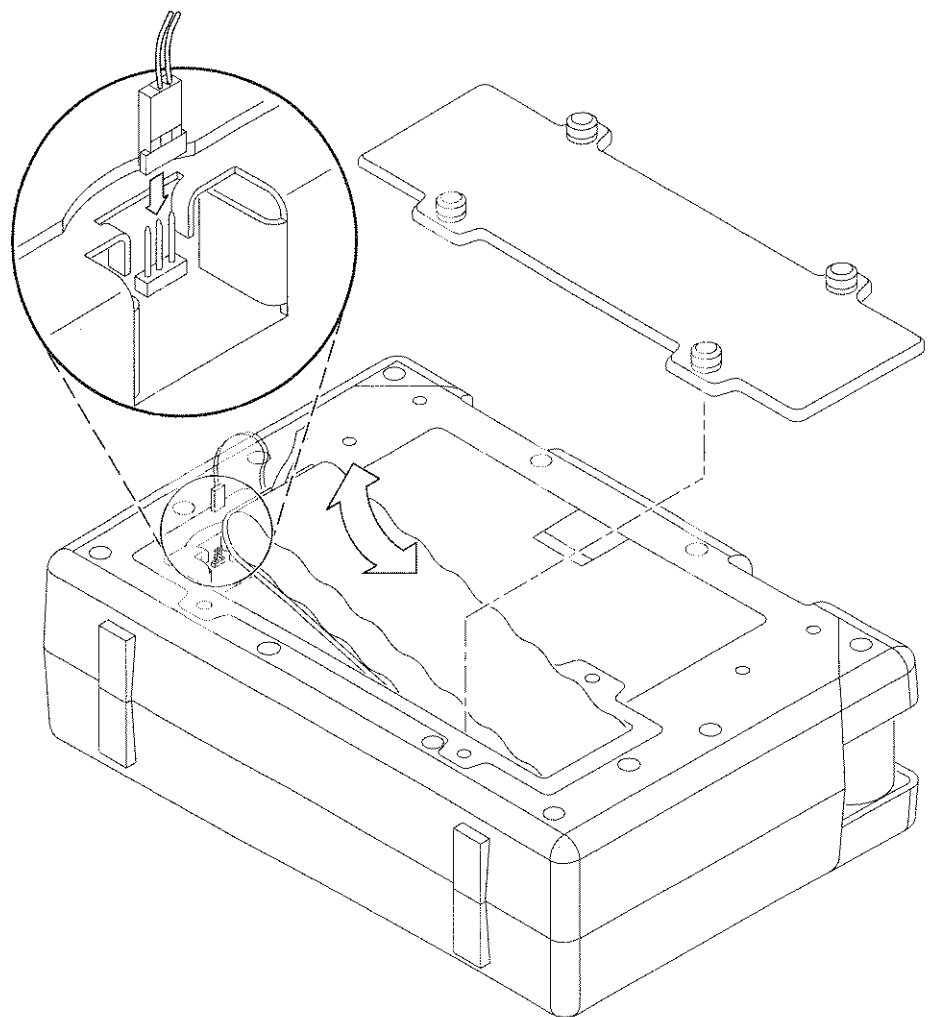

Figure 2-3: Rechargeable NiCd battery pack

Explanation of Readouts

Refer to the sample measurement screen in Figure 2–4 while reading the list of commonly-used display readouts and labels following the illustration.

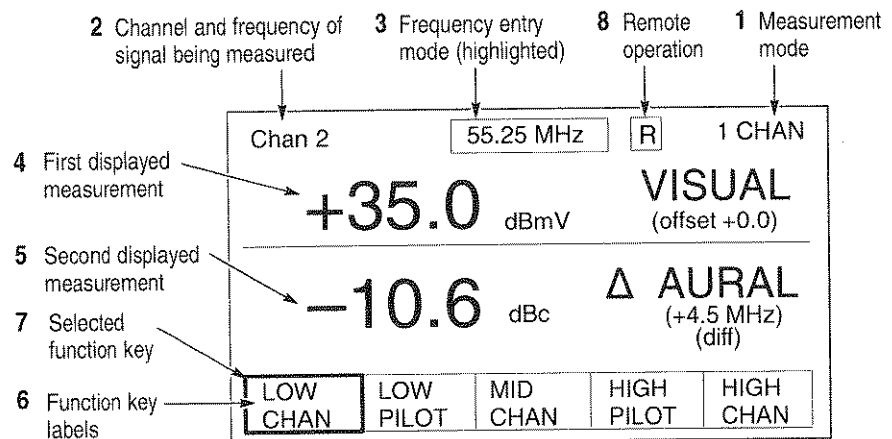

Figure 2–4: Display readouts and labels

1. The measurement mode is shown in the upper right corner, and the screen scale factor (if applicable) appears below it.
2. The top line of the screen shows the channel number and frequency of the signal being measured.
3. An outline around either the channel number or frequency indicates the entry mode. (A dashed outline indicates that the knob and keypad are uncoupled.) In Figure 2–4, the frequency is outlined, so keypad or knob entries will be interpreted as frequency, unless CHAN is pressed to change the entry mode to channel.
4. Typically, this measurement is the visual carrier level. It is displayed in a larger type size than the rest of the display, with the units appearing next to the measured value.

An asterisk (*) next to a measured level indicates that a channel-specific amplitude offset (as set in the channel table) has been applied to the measured value. To find the actual offsets, press UTIL, then select F3 (CHAN TABLE) and F2 (EDIT CHANS). Note that the amplitude offset (at the bottom of the screen) is different than the probe loss offset.

5. In Figure 2–4, the second measurement on the screen is the aural carrier level difference. It is displayed in a larger type size than the rest of the display, with the units appearing next to the measured value. Other measurements, such as C/N, Hum, FM DEV, and D/U can appear here.
6. Labels across the bottom of the screen define function key selections. When the corresponding function key is pressed, the labeled action occurs, or the labeled submenu is displayed. When the function keys are assigned to the presets, as in Figure 2–4, pressing a function key tunes the instrument to the programmed preset frequency. Programming the presets is described on page 3–80.
7. When the function keys control the knob assignment, the highlighted label indicates the current knob action. If the function keys are assigned to the presets, as in Figure 2–4, the highlighted label represents the instrument tuning.
8. When a remote signal is sent to the RF analyzer, it places the instrument in remote operating mode. The remote indicator (an outlined R) appears to the right of the frequency at the top of the display. When any front-panel control is used (other than the POWER key), it will convert the instrument to local operation; all front-panel controls will be functional and the remote indicator will be removed.

When a remote command for local lock-out is sent to the RF analyzer, the local lock-out indicator (an outlined L) will appear to the right of the frequency. There will be no action when a front-panel control is used, except for the POWER key. This condition will remain until the remote command is sent to remove the local lock-out.

If the RF analyzer is operating off of the battery and there is less than ten minutes of battery life remaining, the low-battery indicator (reversed video BAT) replaces the R or L indicator.

Tuning

You can tune the instrument with either the knob or the numeric keypad. In some modes, you can also tune by pressing a function key that has been assigned a preset.

Entry mode. You can set the instrument to channel or frequency entry mode by pressing CHAN or MHz. The selected mode is indicated by an outline around either the channel or the frequency in the top line of the display.

Tuning by knob. If channel entry mode is selected, turning the knob sequences through the channels in the active channel table. If frequency entry is selected, turning the knob tunes by frequency.

In some modes, the function keys determine the knob action. In this case, tuning by knob may only be possible when none of the function key labels are highlighted.

Tuning by keypad. Key in the channel number or frequency, then press CHAN for channel entries, MHz for frequency entries, or ENTER to use the current entry mode.

Tuning by preset. To tune the instrument to a preset frequency, press and release the function key below the desired on-screen label. Refer to page 3–80 for instructions on programming the presets.

In some measurement modes, you measure the signal at a frequency that you have selected through another menu. For example, pilots mode measures high and low pilots, which can be set in the MSMT MODES menu. Access the measurement modes menu using the following path: UTIL–MSMT CONFIG–MSMT MODES–MORE. (You can also use the default settings.)

If you attempt to tune out of the specified frequency range (4.5 MHz to 1080 MHz), no change to tuning will occur (if using the keypad, an out-of-range message will be displayed momentarily). If you tune to a frequency that does not correspond to a channel in the active channel table, the channel readout is replaced with '???' and the secondary measurement is not displayed.

Editing Methods

The next few pages describe the general editing methods used to change instrument parameters.

Selecting an item. In a list of items, the selected item is highlighted by an outline cursor (see Figure 2-5). This is the item that will be acted upon when a function key (such as delete) is pressed. Turning the knob will allow you to select different items, and scroll the list as needed.

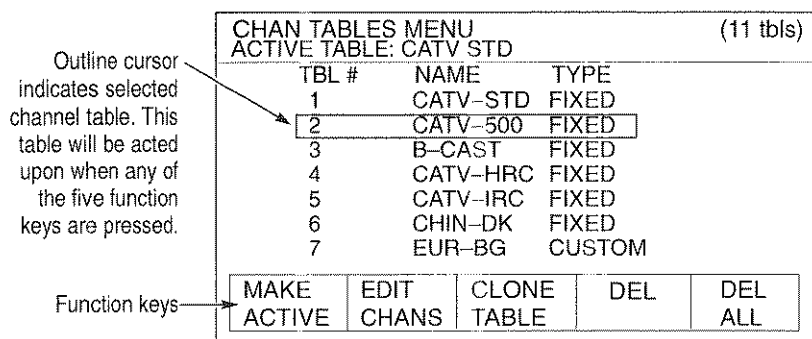

Figure 2-5: Sample menu screen showing use of the outline cursor

Selecting a field. In a display with editable fields, the selected field is indicated by a cursor arrow to the left of the field (see Figure 2–6). The function keys select the field to edit. In some menus, each field is assigned to a corresponding function key. In other menus, one key is pressed repeatedly to sequence through the fields. The function key labels along the bottom of the screen will guide you.

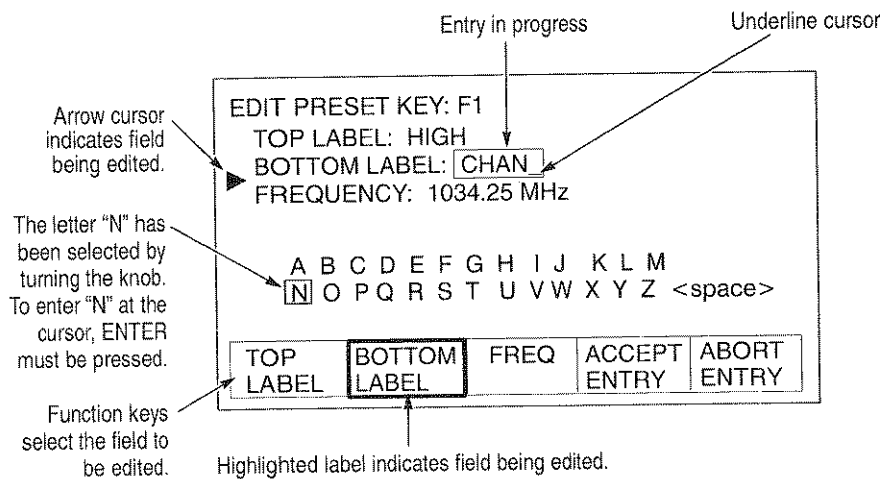

Figure 2–6: Sample menu screen showing text editing

Editing Alpha-Numeric Text Fields

Some fields contain letters and numbers that can be edited by the operator. Preset name is an example of this type of field.

The back space key (←) is used to erase characters.

A partial or incorrect entry can be cancelled by pressing ESC, by selecting ABORT ENTRY, or by back spacing one click past an empty field. The stored name will reappear, unchanged.

Entering letters. Use the knob to highlight the desired letter on screen, then press ENTER. The previous name will disappear and the selected letter will appear, followed by an underline cursor. As additional letters are entered, they will appear at the cursor.

Entering numbers. Use the keypad (ENTER is not used for numbers in text strings). When a field has been correctly entered, select ACCEPT ENTRY.

Exit. When all fields on the screen have been correctly entered and accepted by pressing ACCEPT ENTRY, press ESC to exit the menu, one level at a time. As you back out of the menu, you will be returned to the previous menu and the function key assignments will be reassigned to each new level until you reach a measurement screen.

Editing Numeric Fields

A numeric field can be edited using either the knob or the numeric keypad. To use the knob, just turn the knob until the desired value is displayed, and the new value will be automatically entered. To use the keypad, key in the desired value, then terminate the entry with ENTER. If it is a frequency field, CHAN or MHz can also be used to terminate the entry. Partial keypad entries can be aborted by backspacing or pressing ESC.

Editing Fields With On-Screen Choices

Some fields have on-screen choices, with the current setting indicated by an outline cursor. These fields are edited by turning the knob to the left or right until the desired setting is outlined.

Menu Hierarchy

The menu structure is shown in Figure 2-7, an nine-part illustration. The circles represent the front-panel buttons.

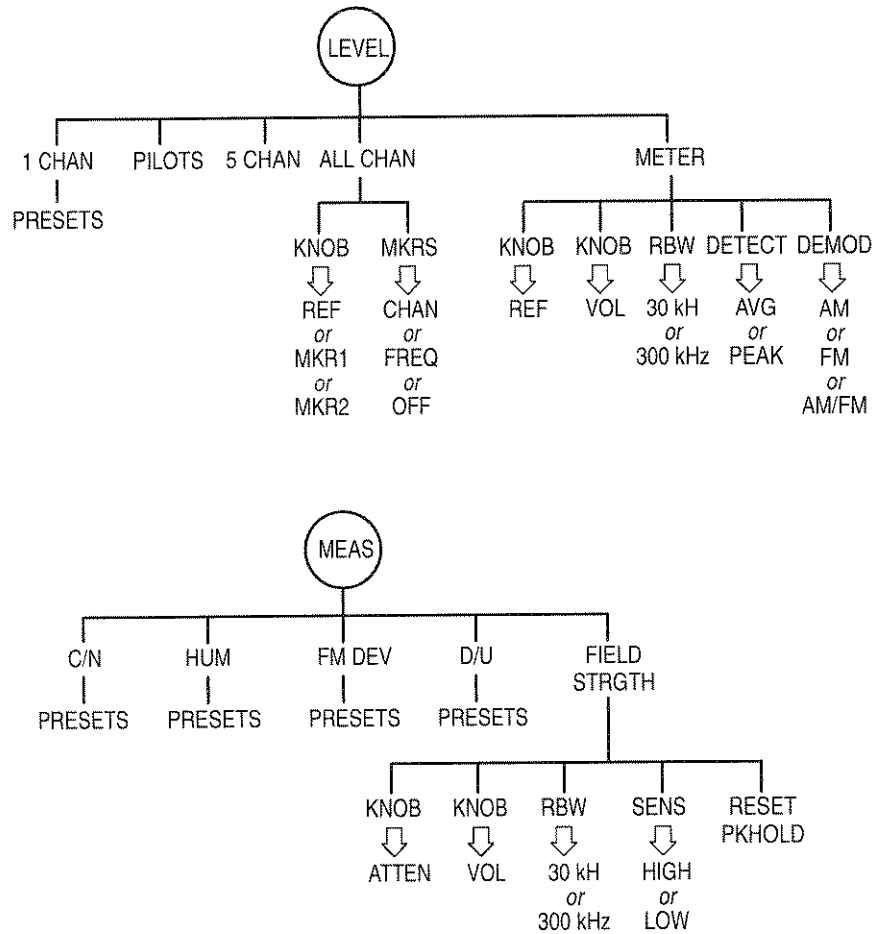

Figure 2-7: Menu hierarchy

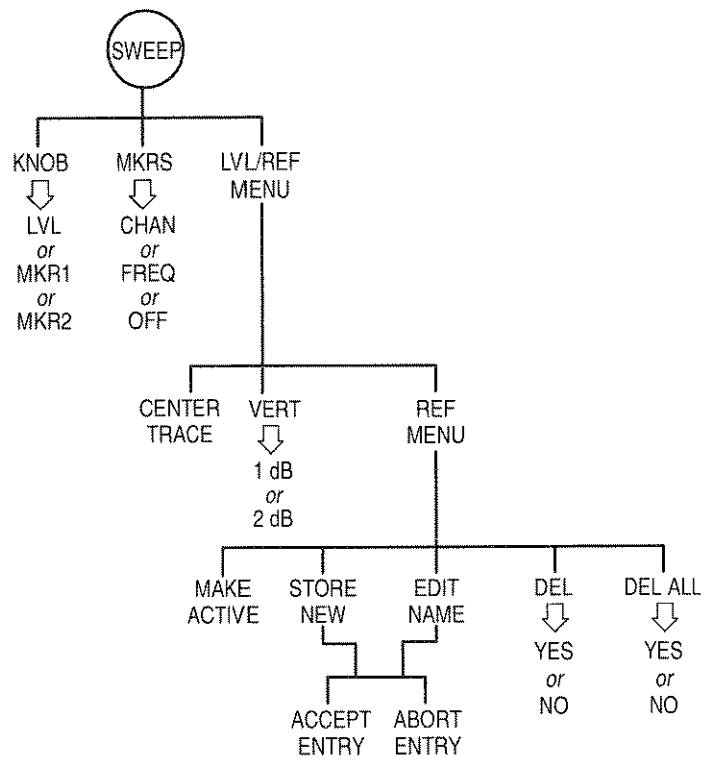

Figure 2-7: Menu hierarchy (cont.)

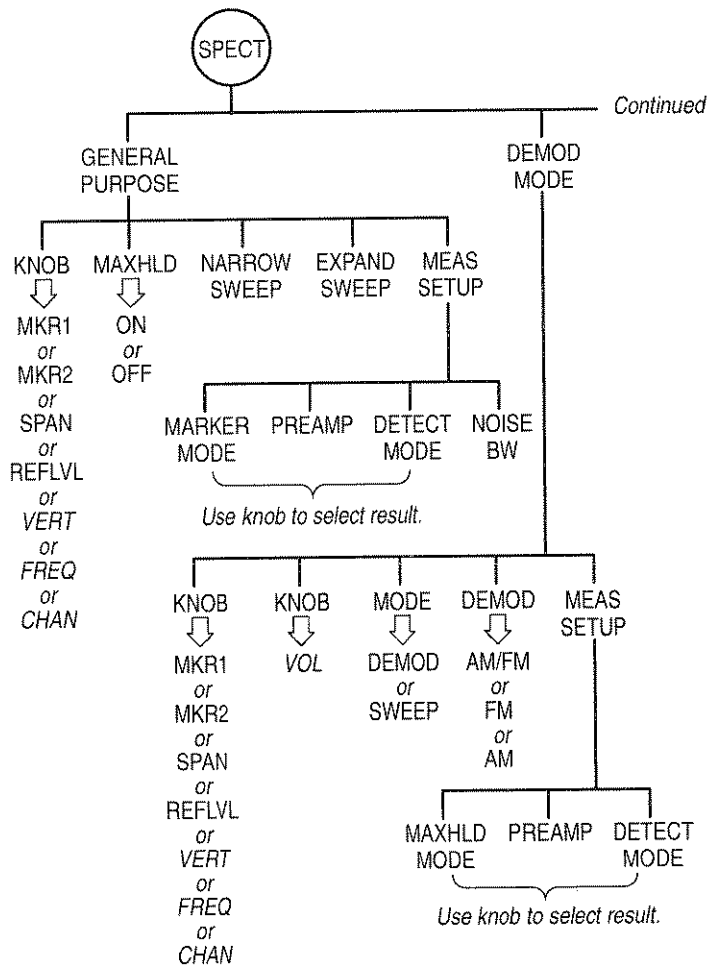

Figure 2-7: Menu hierarchy (cont.)

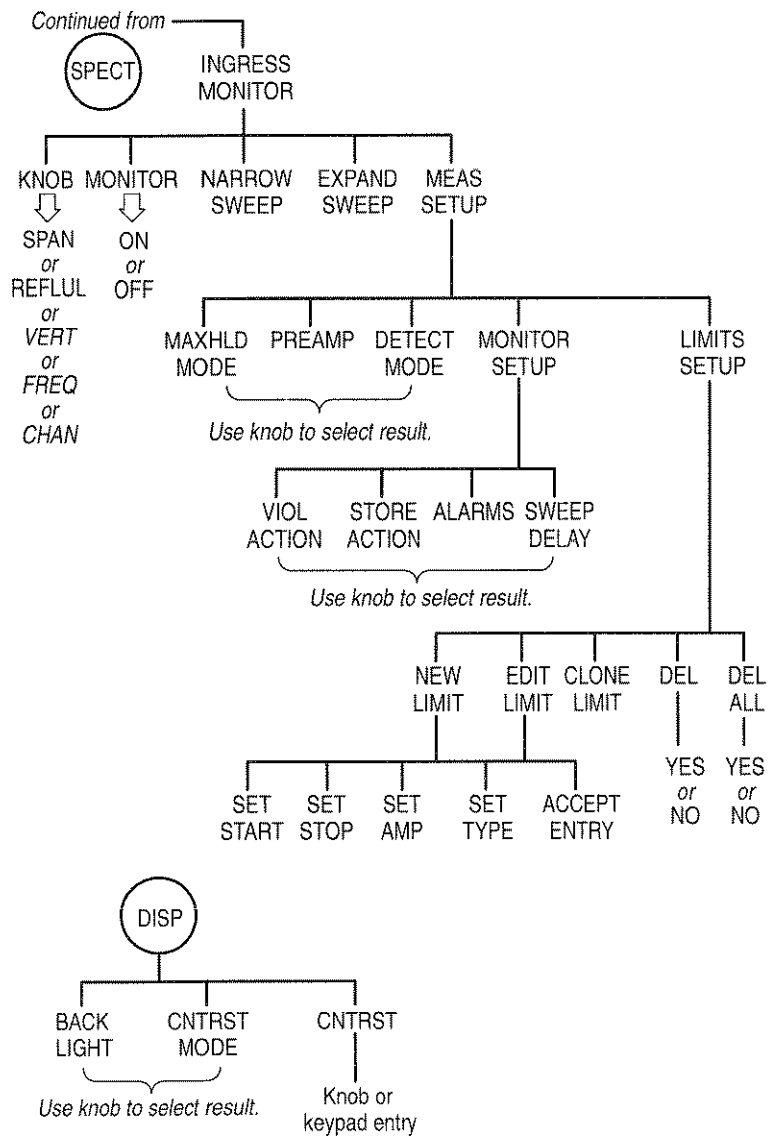

Figure 2-7: Menu hierarchy (cont.)

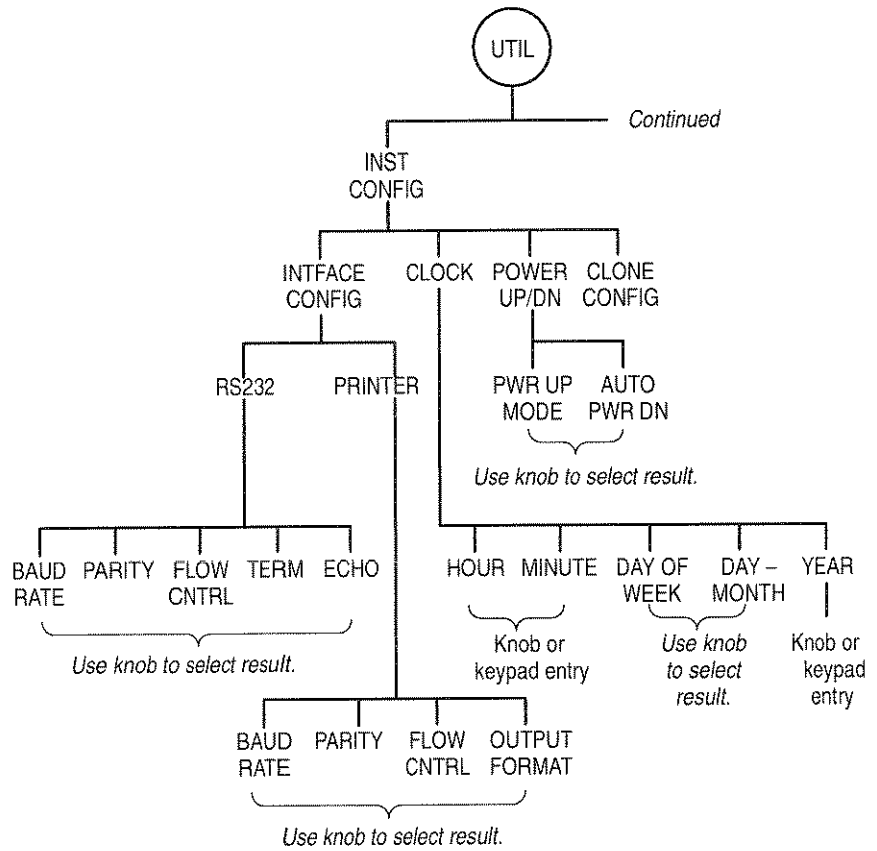

Figure 2-7: Menu hierarchy (cont.)

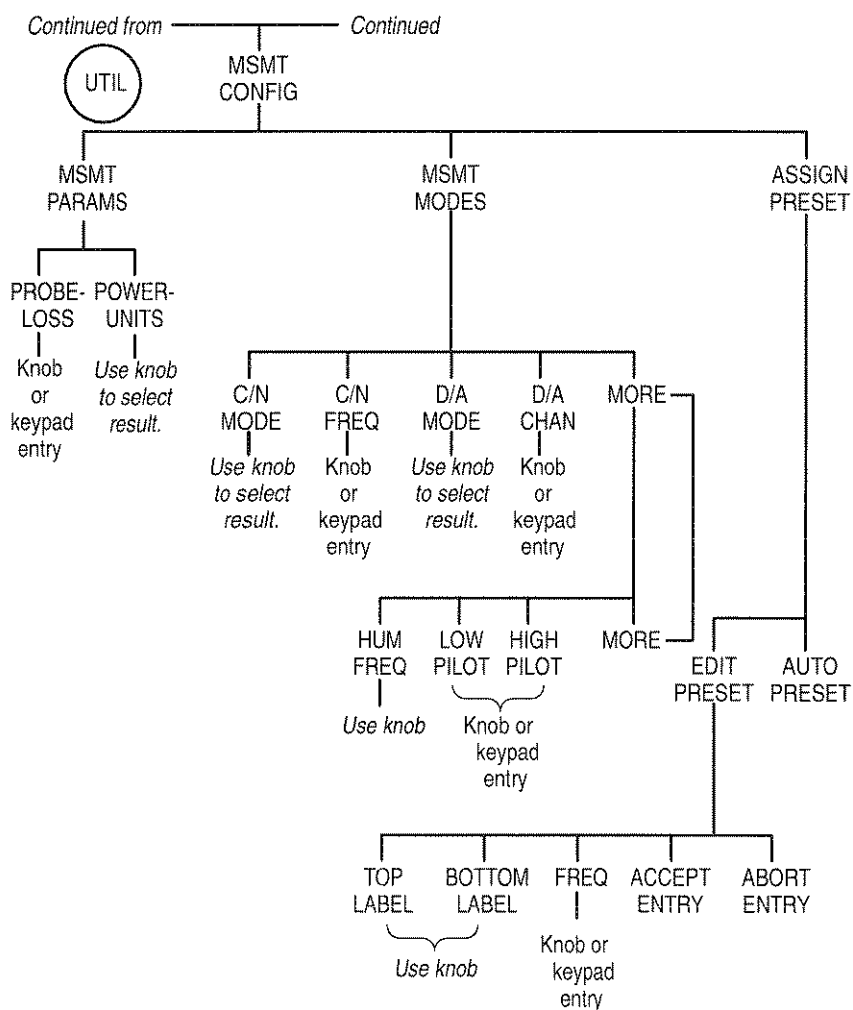

Figure 2-7: Menu hierarchy (cont.)

Functional Overview

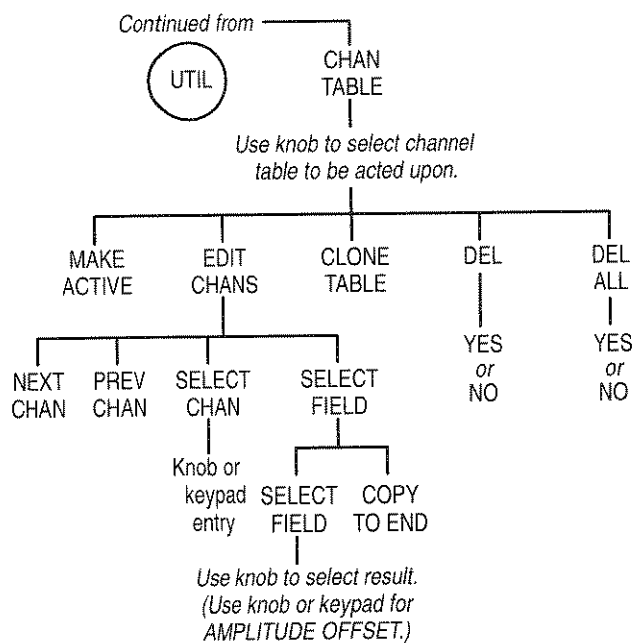

Figure 2-7: Menu hierarchy (cont.)

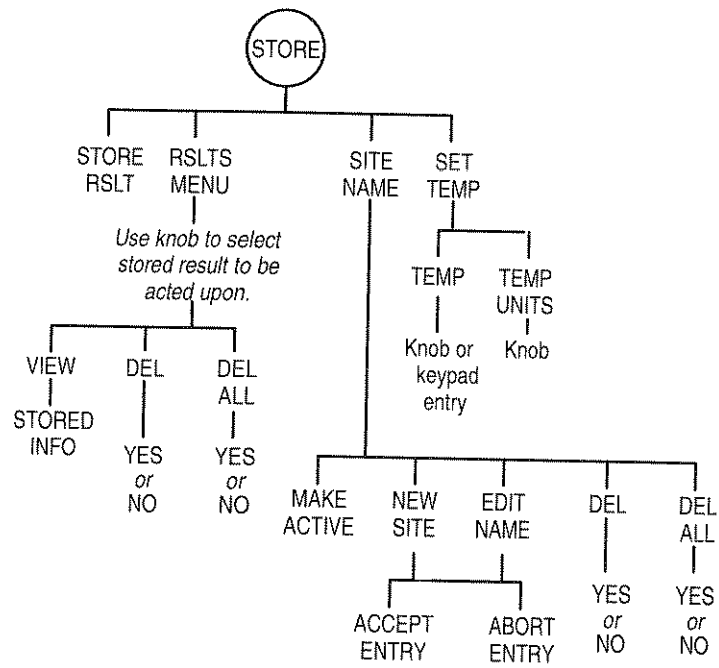

Figure 2-7: Menu hierarchy (cont.)

Functional Overview

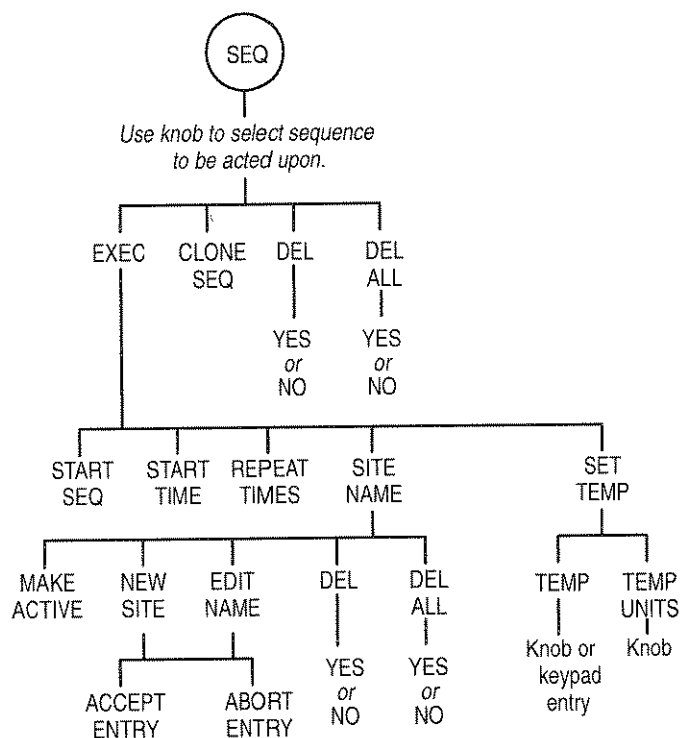

Figure 2-7: Menu hierarchy (cont.)

Measurement Reference

Please read pages 2–6 through 2–11 before proceeding with this section. These pages contain general information about interpreting the displays, tuning, and on-screen editing that applies to all measurements and is not repeated in the measurement discussions.

Figure 2–7 on page 2–12 shows the menu hierarchy, with circles representing front-panel menu keys. Use this figure to determine how to access the measurements and menus discussed in this section.

Each measurement mode discussion in this section begins with a brief description of the measurement itself. Next, each of the active function keys are described in a table. Following this is an in-depth discussion about the measurement and display, including procedures for setting parameters specific to the measurement.

The measurement discussions are organized alphabetically by measurement name. Before reading the discussions of individual measurements, however, read the following discussion on common measurement characteristics.

Common Measurement Characteristics

This section describes two characteristics common to many of the SignalScout RFM151 Cable TV RF Analyzer measurements: channel sensitive measurements, and in-service and out-of-service measurements.

Channel sensitive measurements

Channel sensitive measurements, to be performed accurately, require that the RF analyzer be tuned to a specific frequency corresponding to a channel in the active channel table. Further, channel sensitive measurements must be tuned to the appropriate channel type, digital or analog. For example, to make a visual carrier amplitude measurement, the RF analyzer must be tuned on channel to an analog channel.

Measurement Reference

The following list indicates which measurements are channel sensitive:

- One channel
- Five channel
- Meter
- Carrier-to-noise (C/N)
- Hum
- FM deviation
- Desired-to-undesired (D/U)
- Sweep
- All Channel

If a channel sensitive measurement is performed without being tuned to the correct channel and channel type, the RF analyzer will try to perform a generic signal level measurement or will not make a measurement at all.

One way to ensure that your measurements are tuned on channel for these measurements is to press the CHAN hard key and tune the instrument using the knob or keypad. In most cases, pressing CHAN forces the knob and the keypad to tune the instrument by channel rather than frequency. If you choose to tune the instrument using the keypad, you must follow the entry with CHAN.

In-service and out-of-service measurements

Most of the measurements enabled by the RF analyzer are in service measurements; that is, they can be performed continuously without operator intervention once executed. Two measurements are, or are capable of, out-of-service measurements. Out-of-service measurements require operator interaction by way of prompts displayed during the measurement.

Carrier-to-noise measurements can be made either in-service or out-of-service. Desired-to-undesired measurements can only be made out-of-service.

1 Channel Mode

To enter the 1 channel mode, press the front-panel LEVEL key. The function keys will be assigned to the five signal level measurement modes, but the measurement portion of the screen will not be affected. Select 1 CHAN; the 1 channel measurement display will appear (Figure 3-1). The instrument mode (1 CHAN) is displayed in the upper right corner of the screen, and the function key labels indicate the five presets. Table 3-1 defines the key actions.

Table 3-1: Functions of active keys in 1 channel mode

Key	Action
Menu keys	Enters selected menu. (Aborts a partial keypad entry.)
Function keys	Tune instrument to preset frequencies. Override partial keypad entry.
Knob	Tunes instrument according to entry mode. Overrides partial keypad entry.
Numeric keypad	Keying in either channel or frequency, followed by CHAN, MHz, or ENTER.
CHAN	Terminates keypad entry as channel. Switches to channel entry mode.
MHz	Terminates keypad entry as frequency. Switches to frequency entry mode.
ENTER	Terminates a keypad entry in the active entry mode (channel or frequency, as outlined in the top line of the display).
	Pressing backspace during a keypad entry erases the character preceding the cursor. Backspacing 1 click after field is empty aborts partial entry.
HELP	Displays context-sensitive help screen; aborts a partial keypad entry.
ESC	Aborts a partial keypad entry without changing the instrument setup. Escape has no function when the preset keys are displayed.

Tuning. The signal being measured is determined by instrument tuning. Use the knob, numeric keypad, or presets to tune by channel or frequency. (Refer to *Tuning* on page 2–8.) The tuned channel number and frequency appear on the top line of the display.

Analog Channel Measurement. The instrument makes two measurements on the tuned channel (shown in Figure 3–1). The top portion of the display is the visual carrier (taken as a sine wave at the peak of the modulating envelope). The lower portion of the screen displays the aural carrier level difference, expressed relative to the visual carrier level. If the analog channel is a two-carrier sound channel, both of the aural carrier level differences are measured, relative to the visual carrier.

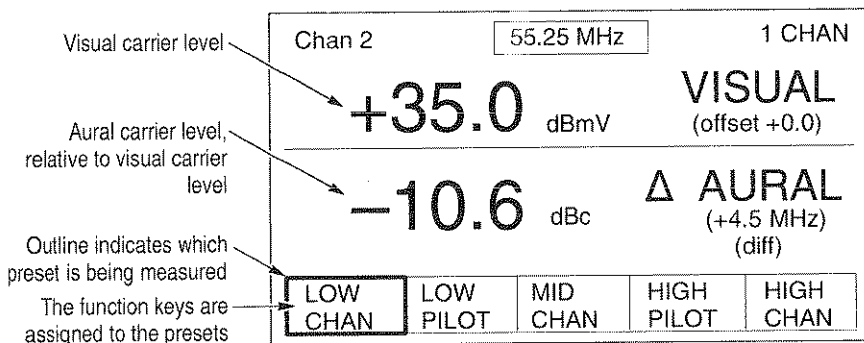

Figure 3–1: The 1 channel mode (analog channel)

Digital Channel Measurements. When making a one channel measurement on a digital channel, a digital average power measurement is always performed. When measuring a digital channel in a hybrid system (analog and digital channels in the channel table), the one channel measurement can also make a visual (analog) to digital difference measurement.

The visual to digital difference measurement measures the difference between the visual carrier peak amplitude of an analog channel in the channel table and the average power of a digital channel. If no analog channel is found in the channel table, or if the channel

specified in step 4e of the following procedure is not an analog channel, only the digital average power measurement is made.

NOTE. To measure the power of a digital channel, you must create a custom channel table. Refer to the SignalScout CSS151 Software User Manual for instructions on creating a custom channel table and loading channel tables into the RF analyzer.

To make a visual to digital carrier difference measurement, use the following procedure.

1. Use the Channel Table Editor (part of the SignalScout application) to create a custom channel table with the information shown in Table 3–2.

Table 3–2: Custom channel table parameters

Channel table item	User action
Visual or Center Freq (MHz)	Enter the measurement frequency (the frequency at the center of the modulation envelope)
RFM150/1 Channel Type	Select DIGITAL or the appropriate analog channel type (NTSC, PAL, or SEACAM).
Channel Edge (MHz)	Enter the difference between the lower edge of the modulation envelope and the center frequency of the channel. For example, a digital channel with a 6 MHz wide modulation envelope would have a Channel Edge of –3 MHz.

2. After all channels in the system have been correctly specified, load the custom channel table into the SignalScout RF analyzer using the procedure described in the *SignalScout CSS151 Software User Manual*.
3. Make the custom channel table the active table as follows:
 - a. Press UTIL.
 - b. Press F3 (CHAN TABLE)

- c. Using the knob, select the appropriate channel table. The selected channel table will be highlighted.
 - d. Press F1 to make it active.
 4. Specify an analog channel in the channel table for the difference portion of the measurement as follows:
 - a. Press UTIL.
 - b. Press F2 (MSMT CONFIG) then F2 (MSMT MODES) again.
 - c. Press F3 (D/A MODE).
 - d. Use the knob to select either AUTO or MANUAL.

AUTO will cause the RF analyzer to use the nearest adjacent analog channel in the channel table for the difference measurement. MANUAL will cause the instrument to use the channel specified in MANUAL ANALOG CHANNEL (see step 4e).
 - e. If you chose MANUAL in step 4d, press F4 (D/A CHAN) and select the analog channel using the knob or the keypad. Keypad entries must be followed by CHAN or ENTER. For the difference measurement to work, the channel specified must be an analog channel and it must be in the active channel table.
 5. Take an average power measurement on a digitally-modulated channel as follows:
 - a. Press LEVEL, then press F1 to select the 1 channel measurement mode.
 - b. Tune to the digital channel. The measurement is displayed.

The average power of the digital carrier is displayed in the top portion of the screen along with the channel amplitude offset and the digital carrier modulation envelope width. (The modulation envelope width is calculated from the Channel Edge value in the current channel table.) The carrier difference measurement is displayed in the lower portion. See Figure 3-2.

The difference measurement is calculated as indicated below:

$$\Delta \text{VISUAL} = V_{\text{peak}} - D_{\text{avgpwr}}$$

Where:

V_{peak} = Peak amplitude of the visual carrier of the nearest analog channel in the channel table (or the selected analog channel)

D_{avgpwr} = Average power of the digital carrier

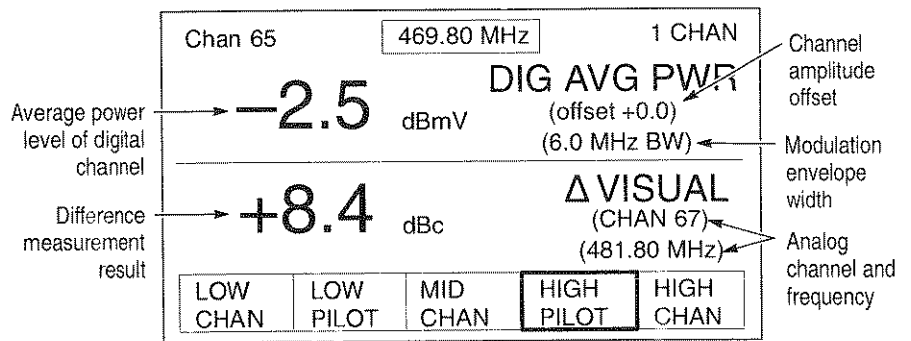

Figure 3-2: The 1 channel visual carrier difference measurement display

To the right of the average power result are the channel amplitude offset and the width of the digital carrier modulation envelope. The width of the digital carrier modulation envelope is based on the Channel Edge value for the current channel.

If no analog channel is present in the channel table, or if the channel specified in step 4e above is not an analog channel, only the digital average power measurement is made and the lower portion of the screen is blank.

NOTE. Digital average power measurements are also made for digital channels in the Pilots, 5 Chan, All Channel, and Sweep modes.

5 Channel Mode

To enter the 5 channel mode, press the front-panel LEVEL key. The function keys will be assigned to the five signal level measurement modes, but the measurement portion of the screen will not be affected. Select 5 CHAN; the 5 channel measurement screen, shown in Figure 3–3, will appear.

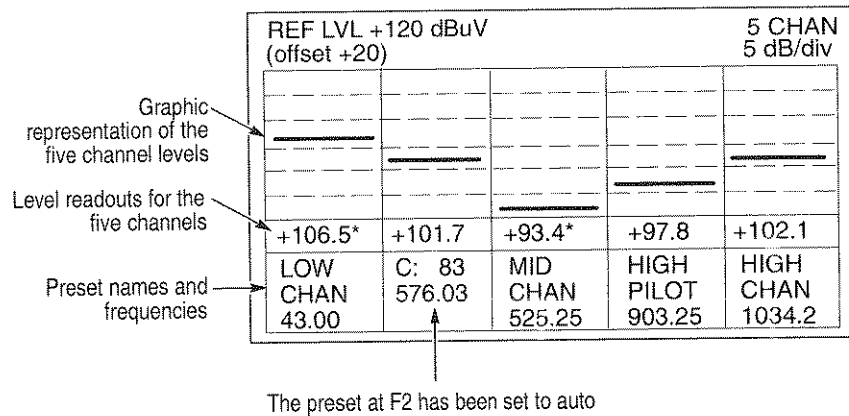

Figure 3–3: The 5 channel mode display

The instrument mode (5 CHAN) will be displayed in the upper right corner of the screen. The function keys and tuning are inactive in this mode. Table 3–3 defines the key actions.

Table 3–3: Functions of active keys in 5 channel mode

Key	Action
Menu keys	Enters selected menu.
HELP	Displays context-sensitive help screen.

The 5 channel measurement screen provides a graph and numeric readout on five preset frequencies. For analog channels, the RF analyzer measures the peak amplitude of the visual carrier. For digital channels, average power measurements of the digital carrier are reported. For off-channel measurements, generic amplitude measurements are made. The vertical range is 30 dB; 6 divisions at 5 dB per division.

Reference level. This is the level at the top of the screen, and is displayed in the upper left corner of the screen (REF LVL). The SignalScout RF analyzer automatically selects the optimum reference level, based on the five channel level measurements.

Signal frequencies. The five preset names and frequencies are displayed across the bottom of the screen. These are the frequencies of the signals being measured, and they can be reprogrammed through the utility menu or by the press-and-hold method. The auto presets notation is 'C:'. See page 3–80 for instructions on programming the presets.

All Channel Mode

All channel mode gives an overview of all channels in the active channel table. This may be useful as the first measurement made at a new location. For example, if you spot a channel in the graphic display that looks low, you can tune the markers to that channel to check its level. You can check at a glance to see if channels at the high end are rolled off.

To enter the all channel mode, press the front-panel LEVEL key. The function keys will be assigned to the five signal level measurement modes. Select ALL CHAN. The all channel measurement screen, shown in Figure 3-4, will appear, with the instrument mode (ALL CHAN) displayed in the upper right corner of the screen.

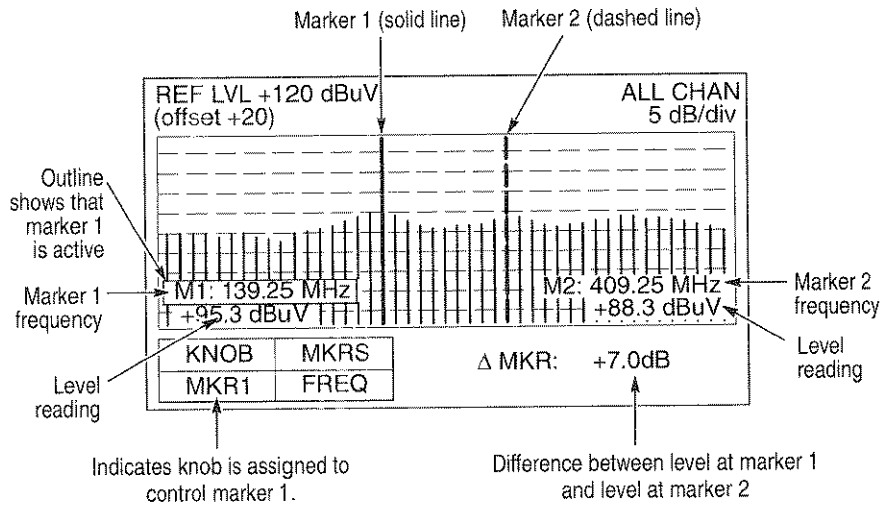



Figure 3-4: The all channel mode display

Table 3–4 defines the key actions.

Table 3–4: Functions of active keys in all channel mode

Key	Action
Menu keys	Enters selected menu. (Aborts a partial keypad entry.)
Function keys	F1 assigns the knob to adjust the reference level (REF), marker 1 (MKR1) or marker 2 (MKR2). F2 toggles the marker readouts between channel or frequency based, or turning the markers and readouts off.
Knob	Tunes the active marker when the on-screen label for F2 reads either CHAN or FREQ. Tunes the reference level when the on-screen label for F1 reads REF.
Numeric keypad	If the on-screen label for F2 reads either CHAN or FREQ, keying in a channel or frequency followed by CHAN, MHz, or ENTER tunes the active marker (provided the keyed channel or frequency corresponds to a channel in the active channel table). The reference level can not be entered using the keypad.
CHAN	Terminates a keypad entry as channel and selects channel based marker readouts.
MHz	Terminates a keypad entry as frequency and selects frequency based marker readouts.
ENTER	Terminates a keypad entry as frequency or channel (based on currently selected readout mode).
	Pressing backspace during a keypad entry erases the character preceding the cursor. Backspacing 1 click after field is empty aborts partial entry.
HELP	Displays context-sensitive help screen; aborts a partial keypad entry.
ESC	Aborts a partial keypad entry without changing the instrument setup.

Display. In the all-channel mode, the instrument continuously scans all the channels in the channel table and produces a graphical display where the carrier level (peak amplitude of the visual carrier for analog channels, and average power of the digital carrier for digital channels) of each channel is plotted as a vertical bar. The vertical range is 50 dB, 10 divisions at 5 dB per division.

If the higher channels are not used, the all channel display will fill only the left portion of the screen. The companion CSS151 software can be used to create a custom channel table that does not contain unused channels. After making this custom channel table active, screen utilization will be significantly improved for most systems.

Marker Readouts. The two marker readouts, located in the bottom corners of the measurement display, show the frequency or channel setting of each marker and the signal level reading in the current power units (dBmV or dBuV) at that frequency. No level reading will be given for channels that are set to SKIP through the channel table menu, although the marker can be moved to a skipped channel (the amplitude readout will be blank).

If the level reading is replaced by OVER, the reference level should be increased. The difference between the levels at the two marker frequencies appears in the lower right portion of the screen.

When MKRS OFF is selected, only the measurement trace is displayed; marker readouts are not displayed.

Using Markers. By moving the markers you can measure specific frequencies or channels and find difference levels between two marker measurements.

To make measurements with the markers, use the following procedure:

1. Select F2 (MKRS) until either CHAN or FREQ is displayed.

If the on-screen label for F2 reads CHAN, the marker readouts are indicated by channel. If FREQ is displayed, the marker readouts are indicated by frequency. You can also switch between frequency and channel markers by pressing the CHAN and MHz keys.

2. Press F1 (KNOB) until MKR1 is displayed. A box will highlight the M1: readout which indicates that the knob or keypad can be used to tune marker one (the solid vertical line in the measurement display). Keypad entries must be followed by CHAN for channel entries, or MHz for frequency entries.

NOTE. *Tuning using the keypad is limited to frequencies that correspond to channels in the active channel table. If another frequency is attempted, an error message will be displayed, and the tuning will not be changed.*

3. Rotate the knob until the M1: readout indicates the frequency or channel you wish to measure.
4. Press F1 again until MKR2 is displayed. A box will highlight the M2: readout which indicates that the knob or keypad can be used to tune marker two (the dashed line in the measurement display). Keypad entries must be followed by CHAN for channel entries, or MHz for frequency entries.
5. Rotate the knob until the M2: readout indicates the frequency or channel you wish to measure.
6. Read the difference measurement (Δ MKR:) from the bottom right corner of the display.

Measurement Reference

Some times the marker readouts obscure the trace. When this happens and you need to examine the trace more carefully, press F2 (MKRS) until the on-screen label reads OFF. All of the marker readouts are removed from the display and you see only the measurement trace and the label for F1 is changed to REF.

When the on-screen label for F1 reads REF, the knob can be used to adjust only the reference level. The keypad is disabled except pressing CHAN or MHz will change the marker readouts to channel or frequency based respectively and the on-screen label will change to CHAN or FREQ respectively; however, the knob or keypad will not tune the markers until F1 reads either MKR1 or MKR2.

Exit. If you exit the all channel mode and then enter any other measurement mode (except Pilots, 5 Channel, and Sweep), the instrument will be tuned to the same frequency as the active marker. In the spectrum modes, the center frequency will be that of the active marker.

Carrier-to-Noise Ratio

In this mode, the instrument measures both the visual carrier level of the tuned analog channel and the carrier-to-noise ratio. If the RF analyzer is tuned to a digital carrier only an average power measurement is performed. If the instrument is tuned off-channel, only a generic level measurement is performed. Table 3–5 defines the key actions in this mode.

Table 3–5: Functions of active keys in C/N measurement mode

Key	Action
Menu keys	Enters selected menu. (Aborts a partial keypad entry.)
Function keys	Tune instrument to preset frequencies. Override partial keypad entry. In out-of-service mode, provides interactive control of the measurement.
Knob	Tunes instrument according to entry mode. Overrides partial keypad entry. In the out-of-service mode, blanks the measurement results. You must then select a function key to initiate a C/N measurement. The knob is disabled while making an out-of-service C/N measurement.
Numeric keypad	Keying either channel or frequency, followed by CHAN, MHz, or ENTER, tunes the instrument.
CHAN	Terminates keypad entry as channel. Switches to channel entry mode.
MHz	Terminates keypad entry as frequency. Switches to frequency entry mode.
ENTER	Terminates a keypad entry in the active entry mode (channel or frequency, as outlined in the top line of the display).
	Pressing backspace during a keypad entry erases the character preceding the cursor. Backspacing 1 click after field is empty aborts partial entry.
HELP	Displays context-sensitive help screen; aborts a partial keypad entry.
ESC	Aborts a partial keypad entry without changing the instrument setup.

To access the carrier-to-noise measurement display, press Meas then press F1 (C/N). The carrier to noise measurement screen will be displayed. See Figure 3-5. You should see C/N in the upper-right corner of the screen. IN-SERVICE or OUT-OF-SVC will be displayed immediately below C/N, depending on how you set the measurement up in the MSMT PARAMS menu (see page 3-17).

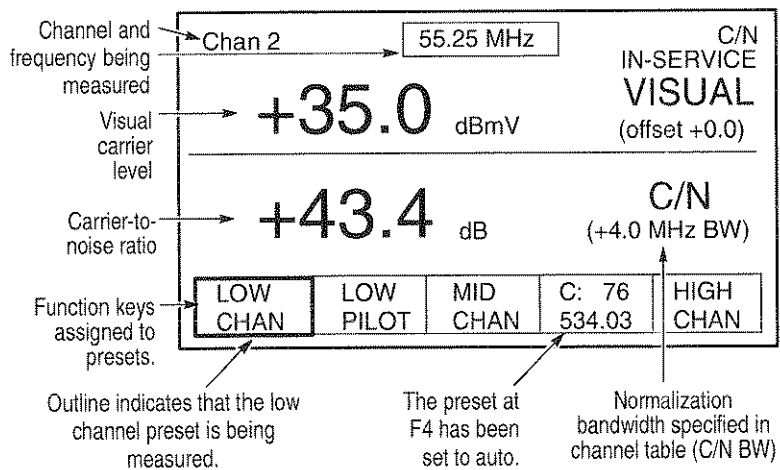

Figure 3-5: Carrier-to-noise measurement screen

The visual carrier level measurement is displayed in the top portion of the screen. The carrier-to-noise measurement is displayed in the bottom portion.

When performing C/N measurements, the SignalScout RF analyzer automatically compensates for the effects of its own equivalent input noise. If the noise level being measured by the RF analyzer is too close to the internal noise floor of the instrument to make an accurate measurement, then a ">" will precede the C/N readout. However when this happens, the actual carrier-to-noise ratio is at least as good as the reported result, and it is probably better.

Both in-service and out-of-service carrier-to-noise measurements can be made. Out-of-service carrier-to-noise measurements measure the noise *within* the normal visual carrier band (in-band), which satisfies

FCC proof of performance specifications. In-service carrier-to-noise measurements measures the noise in the guard band between adjacent channels (out-of-band).

Tuning. You can use the knob, the numeric keypad, or the presets to tune the instrument to the channel you want to measure. (For more information, refer to *Tuning* on page 2–8 and *Presets* on page 3–80.)

Setting In-Service or Out-of-Service modes. Before you make a carrier-to-noise measurement, specify whether it will be an in-service or out-of-service measurement using the following procedure:

1. Press the following keys to access the measurement modes menu: UTIL–F2 (MSMT CONFIG)–F2(MSMT MODES).
2. Press F1 (C/N MODE) and use the knob to select either IN-SVC or OUT-OF-SVC.
3. If you chose out-of-service, press F2 (C/N FREQ) and use the knob or the keyboard to specify the noise frequency offset (the frequency offset from the visual carrier where the noise measurement will be made). If you use the keypad, your entry must be followed by MHz or ENTER.

Making in-service carrier-to-noise measurements.

1. Specify an in-service carrier-to-noise measurement as described above.
2. Press MEAS, then press F1 (C/N). The carrier-to-noise measurement screen (Figure 3–5 on page 3–16) will be displayed.

Making out-of-service carrier-to-noise measurements.

1. Specify an out-of-service carrier-to-noise measurement as described on page 3–17.
2. Press MEAS, then press F1 (C/N). The instrument makes the initial visual carrier measurement and displays the result and prompt as shown in Figure 3–6.

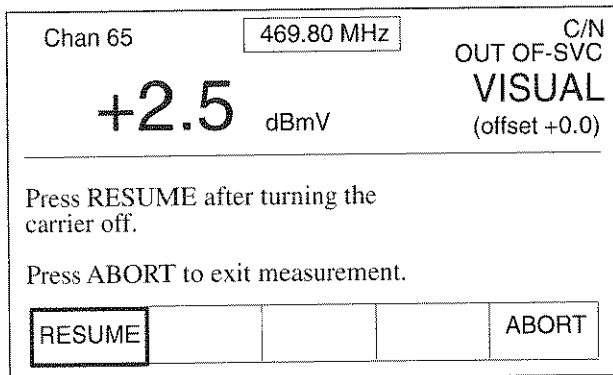

Figure 3-6: First out-of-service C/N prompt

3. After you have turned the visual carrier off, press F1 (RESUME) to continue with the measurement or press F5 (ABORT) to stop the measurement.

If you choose ABORT the results display will be blanked and the bottom of the screen will display a message indicating that the measurement was not completed. The function keys are reassigned to the presets. Press one of the function keys to initiate another measurement.

If you choose RESUME, the instrument will make the noise measurement and display the prompt shown in Figure 3-7.

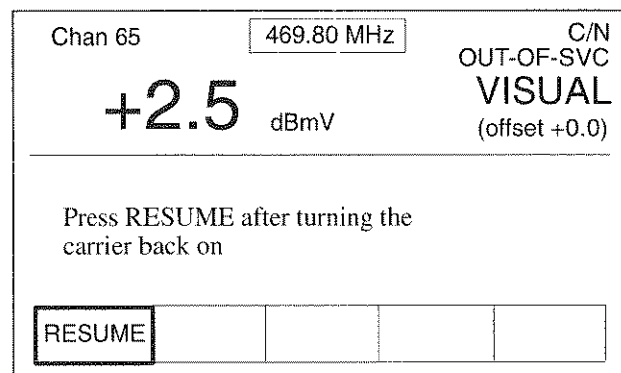

Figure 3–7: Second out-of-service C/N prompt

4. After turning the carrier back on, press F1 (RESUME) and the carrier-to-noise result is displayed in the bottom portion of the screen. All other actions except pressing the POWER button or accessing the online help using the HELP button are ignored. After pressing RESUME, the function keys are reassigned to the presets and the message shown in Figure 3–8 is displayed.

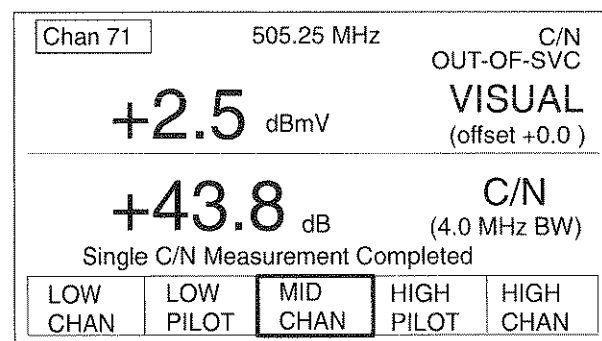

Figure 3–8: Completed out-of-service C/N measurement display

Measurement Reference

If you try to tune the instrument using the knob or the keypad before or after the out-of-service carrier-to-noise measurement, the measurement results will be blanked and a message will be displayed indicating that you must initiate a C/N measurement. You can choose to either exit the carrier-to-noise measurement or initiate a another C/N measurement. Press one of the preset function keys (to make a C/N measurement on another channel), or press MEAS then F1 (C/N) again to make another C/N measurement on the same channel.

Desired to Undesired Mode

Picture or data quality does not degrade for digital carriers until error correction fails. Being able to estimate the operating margin of digitally modulated carriers is critical to keeping a digital system error free. The desired-to-undesired (D/U) measurement mode measures the average power of a digitally modulated RF signal and subtracts the calculated power of the noise in the specified channel bandwidth. The difference is the D/U measurement.

Table 3-6 explains the key actions in this mode. All front-panel keys are disabled during the D/U measurement except those provided for interactive control of the measurement, HELP, and the POWER key.

Table 3-6: Functions of active keys in D/U measurement mode

Key	Action
Menu keys	Enters selected menu. (Aborts a partial keypad entry.)
Function keys	Provides interactive control of the measurement via on-screen prompts. Tunes the instrument to the preset frequencies. Overrides partial keypad entry.
Knob	In the out-of-service mode, blanks the measurement results. You must then select a function key to initiate a D/U measurement. The knob is disabled while making an out-of-service D/U measurement.
Numeric keypad	Keying either channel or frequency, followed by CHAN, MHz, or ENTER, tunes the instrument.
CHAN	Terminates keypad entry as channel. Switches to channel entry mode.
MHz	Terminates keypad entry as frequency. Switches to frequency entry mode.
ENTER	Terminates a keypad entry in the active entry mode (channel or frequency, as outlined in the top line of the display).
	Pressing backspace during a keypad entry erases the character preceding the cursor. Backspacing 1 click after field is empty aborts partial entry.
HELP	Displays context-sensitive help screen; aborts a partial keypad entry.
ESC	Aborts a partial keypad entry without changing the instrument setup.

D/U Measurement. The RF analyzer D/U measurement can only be performed out-of-service and only on digital channels. Furthermore, you have to start and interact with each measurement. Use the following procedure to make an initial D/U measurement:

1. Before making the D/U measurement, select a digital channel table using the procedure beginning on page 3-5.
2. Start the D/U measurement by pressing MEAS then F4 (D/U).

The D/U measurement screen will be displayed as shown in Figure 3-9. D/U should appear in the upper right corner of the screen. The initial measurement is the digital average power measurement of the selected channel.

You are prompted to turn the carrier off and continue with the second part of the D/U measurement, or to stop.

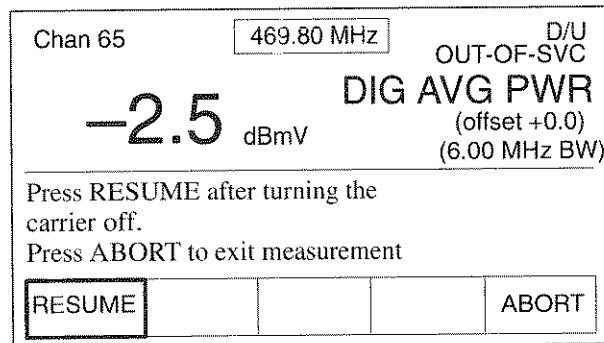

Figure 3-9: D/U measurement carrier off prompt

3. After you have turned the carrier off, press RESUME to continue with the second portion of the measurement.

If you want to stop the measurement, press F5 (ABORT). If you press F5, the measurement results area is blanked and you must use one of the following techniques to start another D/U measurement:

- Choose a digital channel from one of the presets.
 - Tune the instrument to a digital channel using the knob or the keypad.
 - Tune the instrument to a digital channel from another display, then return to the D/U measurement screen.
4. Once the second portion of the measurement has been performed, turn the carrier back on and press F1 (RESUME) as indicated in Figure 3–10.

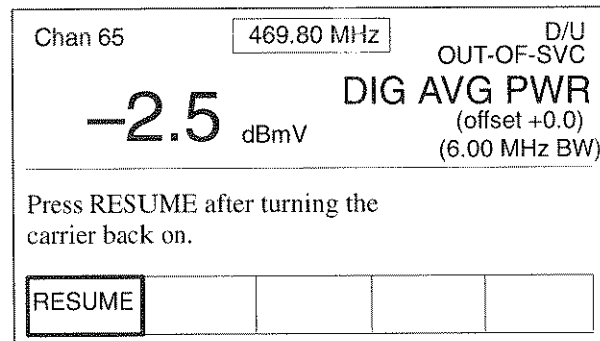

Figure 3–10: D/U measurement carrier on prompt

The D/U measurement result is displayed in the lower portion of the screen. The unit for the D/U result is dB. See Figure 3–11.

If the levels being measured during the undesired portion of the measurement are too close to the RF analyzer internal noise floor to measure accurately, then a “>” will precede the D/U readout. In this case, the D/U result is at least as good as indicated, and it is probably better.

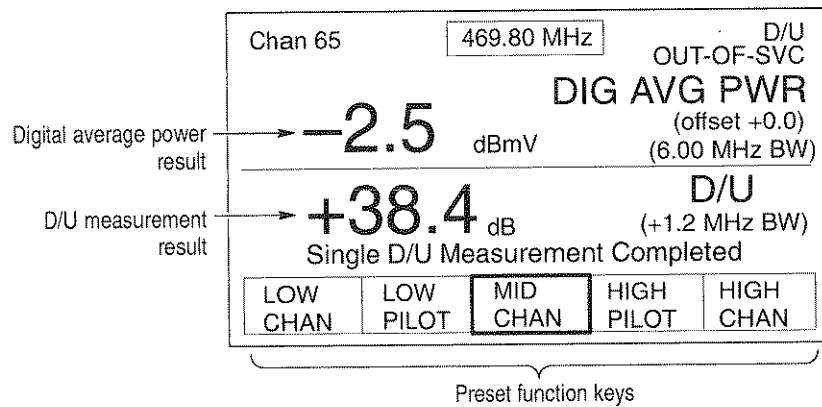

Figure 3–11: D/U measurement results

Knob and keypad functions return to normal after the D/U measurement is completed. The function keys are assigned to the preset frequencies. Tuning the instrument at this point will blank the measurement results.

You can initiate another D/U measurement using one of the techniques described on page 3–23. You can also store the measurement result or exit the display.

FM Deviation

The instrument measures both the visual carrier level and the peak FM deviation of the aural carrier. The FM deviation is the peak deviation of the aural carrier. Note that the FM deviation is dependent on the content of the programming; its value reflects the fluctuating volume of the signal.

Table 3–7 defines the key actions in this mode.

Table 3–7: Functions of active keys in FM deviation measurement mode

Key	Action
Menu keys	Enters selected menu. (Aborts a partial keypad entry.)
Function keys	Tune instrument to preset frequencies. Override partial keypad entry.
Knob	Tunes instrument according to entry mode. Overrides partial keypad entry.
Numeric keypad	Keying either channel or frequency, followed by CHAN, MHz, or ENTER, tunes the instrument.
CHAN	Terminates keypad entry as channel. Switches to channel entry mode.
MHz	Terminates keypad entry as frequency. Switches to frequency entry mode.
ENTER	Terminates a keypad entry in the active entry mode (channel or frequency, as outlined in the top line of the display).
	Pressing backspace during a keypad entry erases the character preceding the cursor. Backspacing 1 click after field is empty aborts partial entry.
HELP	Displays context-sensitive help screen; aborts a partial keypad entry.
ESC	Exits the submenu or menu, one level at a time. Aborts a partial keypad entry without changing the instrument setup.

Measuring FM deviation. Press MEAS. The function keys are reassigned to HUM, C/N, and FM DEV. Select FM DEV. The FM deviation measurement screen, illustrated in Figure 3–12, will be displayed. The top line of the display shows the channel number and frequency of the channel being measured, along with the instrument

mode (FM DEV). The function key labels will indicate the five presets.

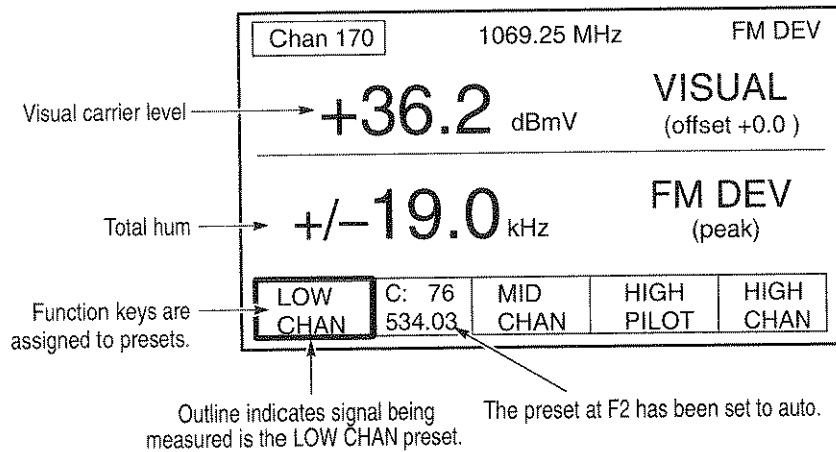

Figure 3–12: The FM deviation measurement mode display

For an analog channel, the top portion of the display is the visual carrier level. The peak FM deviation of the aural carrier is displayed on the bottom portion of the screen. There is no FM deviation measurement for digital or dual-carrier audio channels.

Tuning. You can use the knob, the numeric keypad, or the presets to tune the instrument to the channel you want to measure. (For more information, refer to *Tuning* on page 2–8 and *Presets* on page 3–80.)

Hum

Hum measures the peak-to-peak low frequency disturbances of the tuned carrier. The measurement is made only when the RF analyzer is tuned to analog carriers. If the instrument is tuned to a digital carrier, a digital average power measurement is performed and no hum results are displayed. To access the Hum measurement display press MEAS and F2 (HUM). The Hum measurement screen, similar to Figure 3–13 will be displayed.

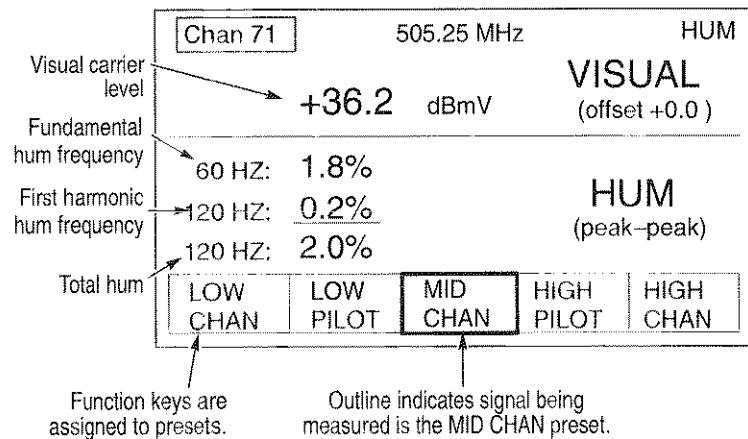



Figure 3–13: The hum measurement mode display

The top line of the screen shows the channel number and frequency of the channel being measured, along with the instrument mode, HUM, in the upper right-hand corner. The function key labels indicate the five preset frequencies. Table 3–8 shows the key actions in this mode.

Table 3–8: Functions of active keys in hum measurement mode

Key	Action
Menu keys	Enters selected menu. (Aborts a partial keypad entry.)
Function keys	Tune instrument to preset frequencies. Override partial keypad entry.
Knob	Tunes instrument according to entry mode. Overrides partial keypad entry.
Numeric keypad	Keying either channel or frequency, followed by CHAN, MHz, or ENTER, tunes the instrument.
CHAN	Terminates keypad entry as channel. Switches to channel entry mode.
MHz	Terminates keypad entry as frequency. Switches to frequency entry mode.
ENTER	Terminates a keypad entry in the active entry mode (channel or frequency, as outlined in the top line of the display).
	Pressing backspace during a keypad entry erases the character preceding the cursor. Backspacing 1 click after field is empty aborts partial entry.
HELP	Displays context-sensitive help screen; aborts a partial keypad entry.
ESC	Aborts a partial keypad entry without changing the instrument setup.

Tuning. The instrument displays the visual carrier level (top portion of the screen) and the fundamental hum, first harmonic hum, and total hum for the tuned carrier (lower portion of the screen). You can use the knob, the numeric keypad, or the presets to tune the instrument to the desired signal. (Instructions for instrument tuning are on page 2–8 and instructions for programming the presets are on page 3–80.)

Setting the fundamental hum frequency. The fundamental hum frequency can be set to either 50 or 60 MHz in the Measurement Parameters menu. Access the menu using the following keystroke combination: Press UTIL, and then press F2–F2–F5–F1. Turn the knob to select the appropriate fundamental hum frequency.

Meter Mode

METER provides general purpose level measurement capabilities, with a simulated analog meter and AM and/or FM signal monitoring. The speaker is driven by the AM- or FM-demodulated tuned signal, and is always turned on in the meter mode. Manual configuration of many features in the meter mode provides flexibility for special applications. If you do not require these features, signal level monitoring may be more easily accomplished with the 1 channel mode. The instrument does not autorange in meter mode; the user must select an appropriate reference level. Table 3-9 defines the key actions in this mode.

Table 3-9: Functions of active keys in meter mode

Key	Action
Menu keys	Enters selected menu. (Aborts a partial keypad entry.)
Function keys	Performs the action labeled on screen or assigns the keypad and/or knob to perform the action. Overrides partial keypad entry.
Knob	Controls reference level if F1 is highlighted; speaker volume if F2 is selected. If neither of these two functions is highlighted, then the knob controls tuning according to the active entry mode (either chan. or freq., as outlined in the top line of the display). Overrides partial keypad entry.
Numeric keypad	Keying either channel or frequency, followed by CHAN, MHz, or ENTER, tunes the instrument.
CHAN	Terminates keypad entry as channel. Switches to channel entry mode.
MHz	Terminates keypad entry as frequency. Switches to frequency entry mode.
ENTER	Terminates a keypad entry in the active entry mode (channel or frequency, as outlined in the top line of the display).
	Pressing backspace during a keypad entry erases the character preceding the cursor. Backspacing 1 click after field is empty aborts partial entry.
HELP	Displays context-sensitive help screen; aborts a partial keypad entry.
ESC	Aborts a partial keypad entry without changing the instrument setup.

Measurement Reference

Press the LEVEL key, then select METER. The meter measurement screen, shown in Figure 3–14, will appear, with the instrument mode (METER) displayed in the upper right corner of the screen. The level readout (largest type size on screen) represents the detected energy within the selected RBW filter, centered at the tuned frequency. The offset value (representing probe loss) appears under the level readout, and can be edited (refer to *Probe Loss*, page 3–85).

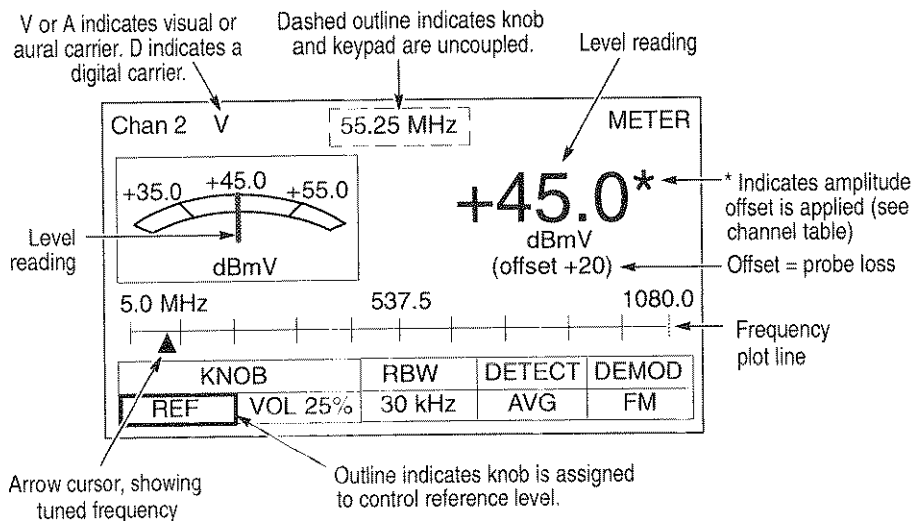

Figure 3–14: The meter mode display

The simulated analog meter displays the same value as the level readout. The value can be read according to the meter's numbered scale. The following paragraph tells how to set the reference level for this scale.

Reference level. Press F1 to assign the knob to REF (the label should be outlined). Use the knob to set the reference level so that the level readout (dark line) is within the central area of the meter scale, not off either end of the scale.

Instrument tuning. The keypad controls instrument tuning. If the knob is not assigned to REF or VOL, then the knob also controls instrument tuning (the knob and keypad functions are coupled). The knob assignments can be deselected by pressing CHAN or MHz (without a keypad entry), or by pressing the current knob assignment again. For example, if KNOB REF is selected, pressing F1 again will deselect it and assign the knob to control instrument tuning.

If the knob is assigned to REF or VOL, the keypad still controls instrument tuning. (The knob and keypad functions are uncoupled.) Tuning by preset is not available in this mode.

In meter mode, the channel number at the top of the screen is followed by a V or an A to indicate whether the instrument is tuned to a visual or an aural carrier. If the instrument is tuned to a digital channel, D replaces the V or A.

NOTE. *The Meter mode always measures the peak amplitude of the detected carrier regardless of whether the channel is digital or analog, or whether the instrument is tuned on or off channel.*

Volume. In meter mode, AM and/or FM audio can be monitored. Pressing F2 assigns the knob to control the speaker volume, from 0% to 100%. A beep will sound if you exceed either end of the range. Note that the instrument must be tuned to an AM or FM carrier in order to monitor audio.

Resolution bandwidth. Pressing F4 toggles the resolution bandwidth between 30 kHz and 300 kHz. Control of RBW can be used in 2-carrier sound systems to resolve the aural carriers.

Detection. Pressing F5 toggles between peak and average detection.

AM and FM demodulation. The Meter mode allows you to demodulate both AM and FM carriers. F5 (DEMODO) cycles through three demodulation choices:

- AM only (AM)
- FM only (FM)
- AM and FM (AM/FM)

Pilots Mode

To enter the pilots mode, press the LEVEL key. The function keys will be assigned to the signal level measurement modes. The measurement portion of the display will be the last-selected measurement mode, which will be highlighted. Select PILOTS. The pilots measurement screen will appear (see Figure 3–15), with the mode (PILOTS) displayed in the upper right corner of the screen.

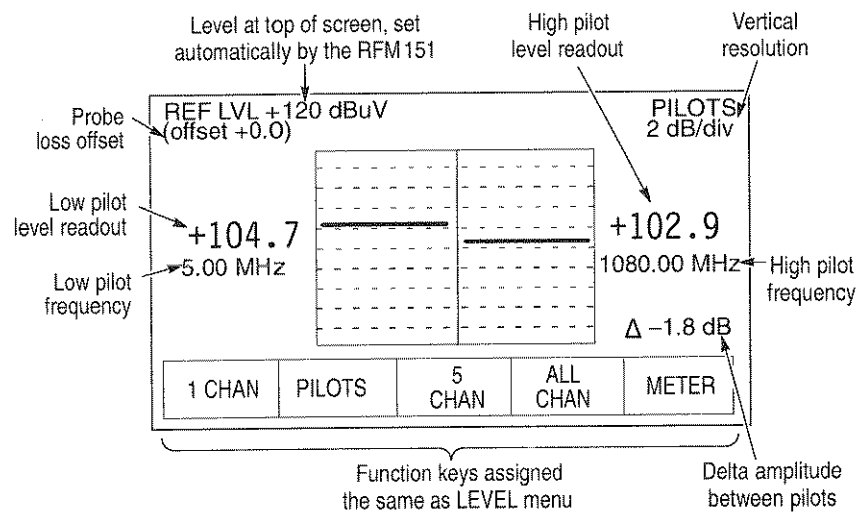

Figure 3–15: The pilots mode display

Tuning is inactive in this mode. Table 3–10 defines the key actions.

Table 3–10: Functions of active keys in pilots mode

Key	Action
Menu keys	Enters selected menu. (Aborts a partial keypad entry.)
Function keys	Initiates the indicated level measurement.

Table 3–10: Functions of active keys in pilots mode (Cont.)

Key	Action
HELP	Displays context-sensitive help screen; aborts a partial keypad entry.
ESC	Aborts a partial keypad entry without changing the instrument setup.

Instead of making two measurements on one channel as in the 1 channel mode, the pilots mode provides a graph and numeric readout of the carrier level for two different channels. For analog channels, the RF analyzer measures the peak amplitude of the visual carrier. For digital channels, average power measurements of the digital carrier are reported. For off-channel measurements, generic amplitude measurements are made. The vertical range is 20 dB; 10 divisions at 2 dB per division.

Pressing certain menu keys will reassign the function keys while leaving the pilots measurement display on screen (for example, pressing STORE to store a measurement result). Press ESC to exit the other menu and return the full pilots display.

To change to another level measurement mode, press LEVEL. To change to another menu, press the desired menu key.

Editing the Pilot Frequencies

The channels being measured are the high and low pilots. The frequencies of the pilots can be set in the MSMT MODES menu. To access this menu, use the following key sequence: UTIL, then select MSMT CONFIG–MSMT MODES–MORE (F2–F2–F5). Function keys F2 and F3 will be assigned to the low and high pilot fields respectively. An arrow cursor along the left edge of the screen will indicate the selected parameter. Select high or low pilot by pressing the corresponding function key, then use the knob or keypad to edit the frequency. A keypad entry must be terminated with MHz or ENTER. A partial keypad entry can be cancelled by pressing ESC or backspacing one space past an empty field. The previous frequency will be restored, without change.

Relative Field Strength Mode

The Relative Field Strength mode is used to make relative field strength measurements using the optional antenna. This mode reports field strength measurements both graphically and audibly. You can use this mode along with the Spectrum modes to find sources of ingress or egress in return band frequencies. Once you have identified the frequency of an unwanted signal, you can attach the antenna and isolate the source.

To access the Relative Field Strength mode, press MEAS then select FIELD STRGTH (F5). You will see the display depicted in Figure 3–16. FIELD STRENGTH should be displayed in the upper right-hand corner of the screen.

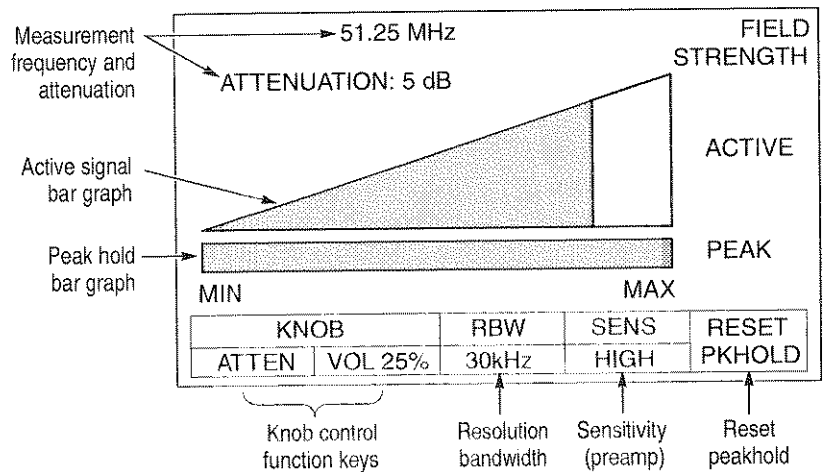



Figure 3–16: The relative field strength mode display

The Relative Field Strength mode reports relative measurements; calibrated or absolute measurements are not provided in this mode.

Table 3–11 describes the key actions for this mode.

Table 3–11: Functions of active keys in relative field strength mode

Key	Action
Menu keys	Enters selected menu. (Aborts a partial keypad entry.)
Function keys	Performs the action labeled on screen or assigns the keypad and/or knob to perform the action. Overrides a partial keypad entry.
Knob	Controls attenuation if F1 is highlighted; speaker volume if F2 is selected. If neither of these two functions is highlighted, then the knob controls the reference level. Overrides partial keypad entry.
Numeric keypad	Keys frequency when followed by MHz or ENTER.
CHAN	Disabled
MHz	Terminates keypad entry as frequency. Switches to frequency entry mode.
ENTER	Terminates a keypad entry as frequency.
	Pressing backspace during a keypad entry erases the character preceding the cursor. Backspacing 1 click after field is empty aborts partial entry.
HELP	Displays context-sensitive help screen; aborts a partial keypad entry.
ESC	Aborts a partial keypad entry without changing the instrument setup.

Display

The display has four components. The readouts at the top of the display indicate the selected frequency and attenuation level. The large triangular area in the middle of the display depicts the relative field strength of the active signal (the frequency of the active signal is the frequency to which the RF analyzer is tuned). The bar at the bottom of the screen represents the max level of the active signal.

Frequency and attenuation readouts. The frequency to which the instrument is tuned is indicated at the top of the display. To tune the RF analyzer, select ATTN (F1) until the on-screen label is not highlighted. The frequency readout will be highlighted with a solid box. Tune the instrument using either the knob or the keypad.

Keypad entries must be followed by MHz or ENTER. You can tune the RF analyzer using the keypad at any time.

The only way to set the attenuation is with the knob. Press F1 (ATTEN) until the on-screen label is highlighted, then adjust the attenuation using the knob. The range of attenuation is 0 to 55 dB in 5 dB increments.

Active and peak signal readouts. The active signal triangle graphically depicts the relative field strength of the tuned signal. As signal strength increases, the triangle is progressively filled in from left to right. As the signal level decreases (for example, you move farther away from a signal source), the filled in area of the triangle also decreases. With the antenna plugged into the RF input of the instrument watch the graphic display and follow the strongest signal level to the source of the unwanted signal.

The peak signal readout (the highest field strength measurement) is provided by the bar graph at the bottom of the screen. This graph is also filled in from left to right as the signal level at the tuned frequency increases. Unlike the triangle, however, the filled in area of the bar graph does not decrease as signal level decreases. You can reset the peak hold graph by pressing F5 (RESET PKHLD) or by changing any of the instrument settings.

In addition to the graphical representation of the signal strength, the RF analyzer also represents the signal strength audibly. Set the speaker volume using the knob. Press F2 (VOL) and rotate the knob to the desired volume. The percent volume is indicated by the on-screen label above the function key. As the signal strength of the tuned frequency increases, the instrument beeps more rapidly, very much like a Geiger counter. As signal strength decreases, the instrument beeps more slowly. At maximum strength (the triangle will be filled in completely), the RF analyzer emits a continuous tone.

Resolution bandwidth and sensitivity. Pressing F3 (RBW) toggles between 30 kHz and 300 kHz resolution bandwidth settings. Pressing F4 (SENS) enables and disables the preamp (HIGH and LOW respectively). See the following procedure to get an idea of how you might use these settings to help you find sources of unwanted signals.

Making Relative Field Strength Measurements

Use the following procedure as an example of how you might use relative field strength measurements to isolate the source of unwanted signals.

1. After you have identified an ingress or egress frequency, tune the instrument to that frequency.
2. Turn the instrument off and attach the RF antenna to the RF input.
3. Turn the instrument back on (it will automatically tune itself to the last tuned frequency) and navigate to the Relative Field Strength measurement display. (Press MEAS, then press F5.)
4. Press F2 and rotate the knob to set the volume of the speaker to the desired level.
5. Press F1 (ATTEN) and rotate the knob to set the attenuation to the desired level. (Starting with a relatively low attenuation setting will help you see and hear the signal more quickly if you do not already have a good idea of the source.)
6. If necessary, press F3 (SENS) until the on-screen label reads HIGH.
7. If necessary, press F4 (RBW) until the on-screen label reads 30 kHz.
8. With the RF analyzer in hand, follow the direction of the strongest signal as indicated by the graphical and audible outputs. This may take some trial and error, eliminating directions as you move around.
9. As the signal strength increases toward maximum, increase the attenuation setting, disable the preamp, and/or toggle the RBW setting.
10. Using more sensitive instrument settings, continue searching until you have isolated the signal source.

Spectrum Mode

The RF analyzer provides three different spectrum measurement modes: General, Demodulation, and Ingress Monitor. The three modes have common features, but each also offers specific capabilities not available in the other two.

- The General Spectrum mode provides traditional spectrum analysis capabilities including multiple markers; maxhold waveform; multiple detection modes; and center frequency, reference level, vertical scale, and preamp control. You can use this mode to make on-screen signal level difference measurements, noise power measurements, and to identify signals that should not be present.
- Demodulation Spectrum mode provides spectrum analysis capabilities similar to the general spectrum mode. Additionally, you can demodulate AM and FM carriers at the active marker frequency. You can use this mode to verify the content of an ingress signal or to verify that a correct channel is being measured by listening to the aural information of the channel.
- Ingress Monitor mode is a specialized spectrum mode designed to detect the presence of ingress. This mode is useful in bi-directional systems for monitoring return path frequencies, especially when it is inconvenient for you to be physically present to make the needed measurements.

To access the spectrum measurement displays, press SPECT. The on-screen readouts for the function keys change as indicated in the following list:

- F1 (GENERAL PURPOSE) accesses the general spectrum mode.
- F2 (DEMODO MODE) accesses the demodulation mode.
- F3 (INGRESS MONITOR) accesses the ingress monitor mode.

Pressing one of the function keys will display the indicated spectrum measurement mode and a spectrum measurement is made based on the current center frequency. The display will look similar to Figure 3-17 and SPECTRUM is displayed in the upper right-hand corner of the screen.

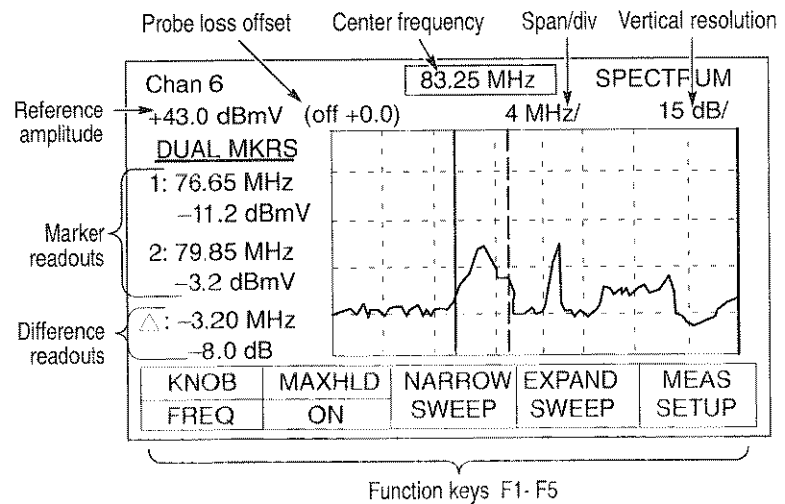



Figure 3–17: The Spectrum mode display

Table 3–12 defines the key actions in the three spectrum modes. Most of the key actions are common; however, actions specific to a particular mode are indicated.

Table 3–12: Functions of active keys in spectrum mode

Key	Action
Menu keys	Enters selected menu. (Aborts a partial keypad entry.)
Function keys	Performs the action labeled on screen or assigns the keypad and/or knob to perform the action. Overrides partial keypad entry.
Knob	Controls the function indicated in the on-screen label for F1. In the demodulation mode, also adjusts the the volume. Overrides partial keypad entry.
Numeric keypad	Keying either channel or frequency, followed by CHAN, MHz, or ENTER, tunes the center frequency. Pressing CHAN or MHz, assigns the knob and keypad to tune the center frequency by channel or frequency respectively.
CHAN	Terminates keypad entry as channel. Switches to channel entry mode.

Table 3–12: Functions of active keys in spectrum mode (Cont.)

Key	Action
MHz	Terminates keypad entry as frequency. Switches to frequency entry mode.
ENTER	Terminates a keypad entry in the active entry mode (chan. or freq.).
	Pressing backspace during a keypad entry erases the character preceding the cursor. Backspacing 1 click after field is empty aborts partial entry.
HELP	Displays context-sensitive help screen; aborts a partial keypad entry.
ESC	Exits the submenu or menu, one level at a time. Aborts a partial keypad entry without changing the instrument setup.

Common spectrum measurement and display features

The information in this section applies to the three spectrum modes except where indicated.

Center frequency. If the on-screen label for F1 reads CHAN or FREQ, the keypad or the knob will tune the center frequency (displayed at the top center of the screen). If F1 reads any other label, then only the keypad controls center frequency tuning. Pressing CHAN or MHz (without a keypad entry) enables either the knob or the keypad to tune the center frequency. For example, with KNOB MKR1 selected, press CHAN to deselect marker 1 and set the knob and the keypad to control center frequency by channel.

Span/division. Control of the span/division is activated by pressing F1 until the on-screen label reads SPAN. Adjust the span/div by turning the knob until the desired setting is displayed above the measurement trace in the center of the screen. Minimum span is 200kHz/div; maximum is 4 MHz/div. Selecting a span/div automatically selects a corresponding resolution bandwidth as indicated in Table 3–13 on page 3–41.

Vertical resolution. The vertical resolution for the spectrum displays can be set to either 2, 5, 10, or 15 dB/division. Adjust this display setting by pressing F1 until the on-screen display reads VERT. Then use the knob to adjust the dB/div scale. The vertical resolution readout is displayed just above the trace in the upper right-hand corner of the screen.

Reference level. The reference level is the level at the top of the screen. The present setting is displayed in the upper left corner of the screen. The reference level can be changed by pressing F1 until the on-screen label reads REFLVL and then turning the knob. Adjusting the reference level moves the trace vertically on the screen.

Resolution bandwidth. Resolution bandwidth in all spectrum modes is adjusted automatically depending on the span/div selected. Table 3-13 indicates the relationship between the two parameters.

Table 3-13: Span/division and resolution bandwidth

Span per division	Resolution bandwidth
200 kHz	30 kHz
400 kHz	30 kHz
1 MHz	300 kHz
2 MHz	300 kHz
4 MHz	300 kHz

Markers. The general spectrum mode provides three marker modes: OFF, DUAL, or NOISE. The current mode is indicated just above the marker readouts to the left of the screen. In the general purpose spectrum mode, specify which marker mode you want to use in the measurement setup menu (press F5 from the general purpose spectrum display). The ingress mode does not use markers and the demodulation mode uses only dual markers.

Marker one is represented as a solid vertical line; marker two is represented as a dashed line. The marker readouts (frequency, amplitude, and difference) are displayed to the left of the trace.

Measurement Reference

Markers are controlled by pressing F1 until the on-screen label reads either MKR1 or MKR2, then turning the knob until the active marker is tuned to the desired frequency. Marker frequency is changed in display pixel steps, and the value of a step depends on the span/div.

When markers are turned off, the readouts disappear and the trace area expands to ten horizontal divisions. (Eight divisions are displayed when the markers are enabled.)

Max hold waveform, preamp, and detection mode. Controls for these three functions are provided in each spectrum mode. In the ingress and demodulation spectrum modes, access to all three functions is provided in the measurement setup menus. In the general spectrum mode, the max hold waveform function is toggled on and off using the F2 function key. Changes to these three parameters in one spectrum mode are reflected in the other two modes.

When max hold waveform and/or the preamp are enabled, and when the detection mode is set to peak, reverse video indicators at the extreme right of the screen are displayed. See Figure 3–18.

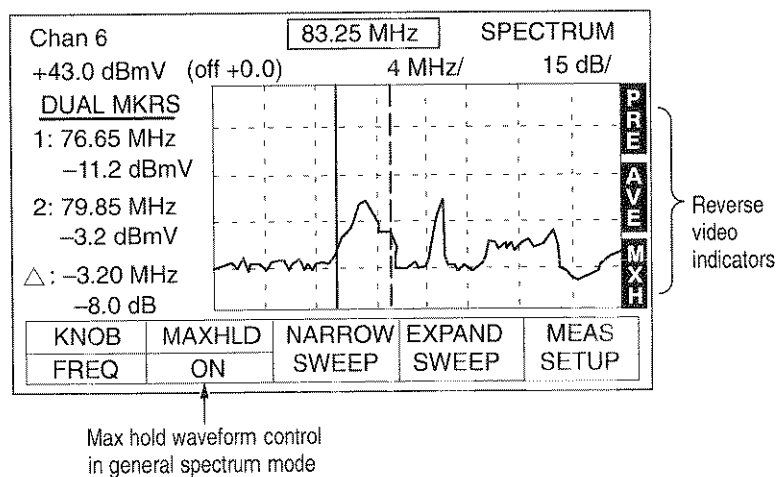

Figure 3–18: Preamp, detection mode, and max hold indicators

With the max hold waveform function enabled, you can display built up traces of unwanted, bursty ingress signals. The waveform is reset any time a different mode or menu is entered, any time the max hold waveform is disabled, or whenever a measurement parameter is changed (for instance, reference level or span/div).

You can use the preamp to decrease the noise floor by roughly 15 dB during spectrum measurements. However, if the preamp is enabled and the reference level is set lower than the levels of some of the channels at the input, internal distortion products can be produced by the instrument and may be visible on screen.

When noise markers are selected (in the general spectrum mode), max hold waveform is disabled, the preamp is enabled, and the detection mode is set to peak.

Windowed sweep. Both the ingress and general spectrum modes allow the range of swept frequencies to be narrowed and expanded. The demodulation mode does not provide this capability. Modifying the range of frequencies swept, allows you to decrease or increase your sweep time. The other function keys act normally with adjusted sweep windows.

You can narrow or expand the range of swept frequencies with markers enabled or disabled, however, the actions are not the same:

- With markers enabled, pressing F3 (NARROW SWEEP) causes the sweep window to decrease to the marker positions (they must be separated by at least one data point). See Figure 3–19.

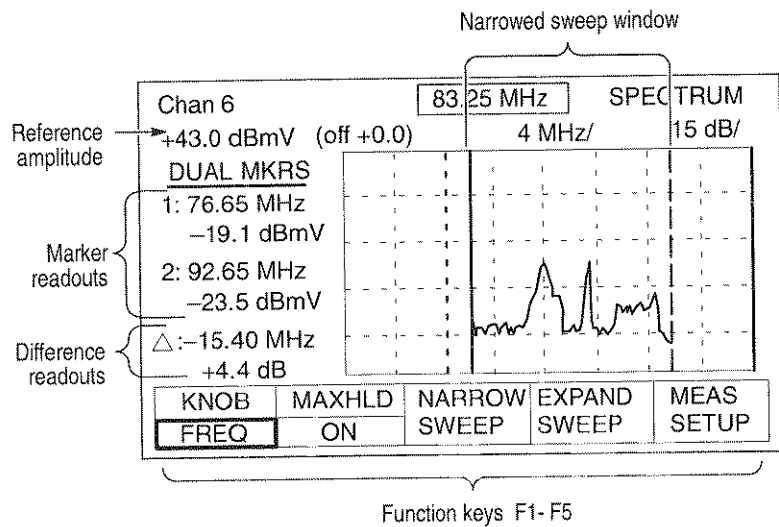

Figure 3-19: Narrowed sweep window in spectrum mode

Pressing F4 (EXPAND SWEEP) causes the sweep window to increase to the marker positions. Pressing F4 again will increase the sweep window in one horizontal division increments (one-half division to the right and the left of the current window).

- With markers disabled, or in the ingress mode, pressing F3 causes the sweep window to decrease by one horizontal division of the current sweep range (one half division from each of the right and left sides). Pressing F4 causes the sweep window to increase by the same amount, in the same manner.

You can tune the center frequency and maintain an adjusted sweep window provided the start and stop frequencies of the new center frequency are within the start and stop frequencies of the unadjusted sweep window (as defined by the span/div and center frequency). If not, the sweep window is returned to the full spectrum sweep.

General Spectrum Mode

The General Spectrum mode provides traditional spectrum analysis capabilities including multiple markers; maxhold waveform; multiple detection modes; and center frequency, reference level, vertical scale, and preamp control. You can use this mode to make on-screen signal level difference or noise power measurements and to identify signals that should not be present.

Measurement setup menu. Enter the General Purpose Spectrum measurement setup menu by pressing the following key sequence: SPECT–F1 (GENERAL PURPOSE)–F5 (MEAS SETUP). The measurement setup menu allows you to control the marker mode (DUAL, OFF, or NOISE), preamp (OFF or ON), detection mode (PEAK or AVG), and noise marker bandwidth.

Options in this menu are selected by pressing the function key associated with the parameter and using the knob to select the option desired. An arrow cursor to the left of the screen indicates which parameter is being edited. Use the knob or the keypad to specify the noise marker bandwidth. Press ESC to accept entries and exit the menu.

The marker mode parameter allows you to choose between the following marker modes:

- Dual markers (DUAL, the default mode) allows you to make amplitude measurements at the marker frequencies and difference measurements.
- No markers (OFF) allows you to increase the range of swept window frequencies to 10 horizontal divisions rather than eight and removes the on-screen markers and the marker readouts.
- Noise markers (NOISE) allows you to make noise power measurements. It is identical to the dual operation mode except the markers are normalized to the bandwidth you specify in the NOISE MARKER BW field.

When noise markers are enabled, if the noise level being measured is too close to the noise floor of the RF analyzer to make an accurate measurement, the “near noise” indicator (>) is displayed to the left of the marker amplitude readout.

Pressing F4 (NOISE BW) allows you to specify a normalization bandwidth for your measurement environment. Enter the value you want using the knob or the keypad. Keypad entries must be followed by pressing MHz or ENTER. The bandwidth you specify is used when the RF analyzer is operating in the noise marker mode. The default value is 1 Hz; however, in some CATV applications, for instance, return path measurements, you may want to specify a different normalization bandwidth.

Demodulation Spectrum Mode

The Demodulation Spectrum mode is an enhanced spectrum mode that allows you to demodulate AM and FM modulated carriers at the markers as well as make general spectrum measurements. Using this mode, you can determine the content of an AM or FM modulated carrier that may be a source of ingress or you can verify that you are measuring the channel you intended using the audio content of the signal.

Press SPECT, then press F2 (DEMODO MODE) and the demodulation spectrum screen will be displayed. See Figure 3–20.

Display. The demodulation spectrum display is similar to the general spectrum display. Two differences are that only dual markers are supported in this mode and there are no windowed sweep capabilities.

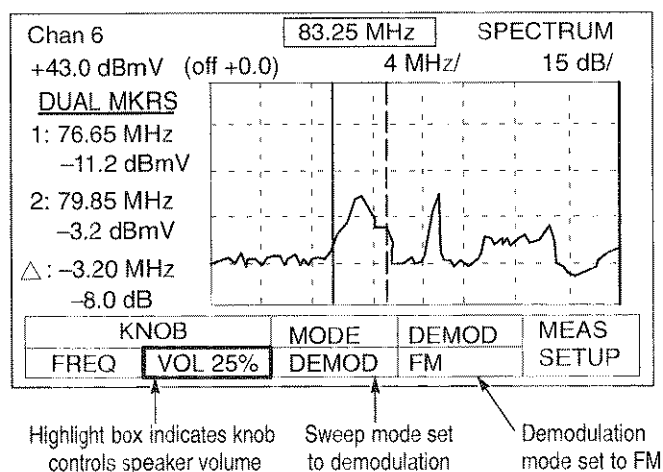

Figure 3-20: Demodulation spectrum display

Spectrum measurements. To make general spectrum measurements from the demodulation display, press F3 (MODE) until the on-screen label reads SWEEP. In this mode the RF analyzer makes continuous spectrum sweeps and the instrument can be used as if the general purpose mode was enabled. Demodulating carriers at the active marker frequencies in the SWEEP mode is disabled.

To demodulate a modulated carrier, press F3 (MODE) until the on-screen label reads DEMOD. The RF analyzer stops making spectrum sweeps and you can now demodulate a carrier at the frequency of the active marker. Demodulation options include:

- AM only (AM)
- FM only (FM)
- Either AM or FM (AM/FM)

Markers and the other display parameters function like the General Purpose Spectrum mode display parameters.

Demodulation measurements. To demodulate AM and/or FM signals at the marker frequencies, use the following procedure:

1. After making a spectrum measurement, press F3 (MODE) until the on-screen label reads DEMOD. The last spectrum measurement is displayed and the RF analyzer stops sweeping.
2. Select which type of signal the instrument will demodulate by pressing F4 (DEMOM) until the on-screen label reads either AM, FM, or AM/FM.
3. Set the speaker volume by pressing F2 (VOL) and adjust the level with the knob.
4. Tune a marker to the desired frequency.

To return to a normal spectrum sweep, press F3 until the label reads SWEEP.

Measurement setup menu. Enter the Demodulation Spectrum measurement setup menu by pressing the following key sequence: SPECT–F2 (DEMOM MODE)–F5 (MEAS SETUP). The measurement setup menu allows you to control the max hold waveform (OFF or ON), preamp (OFF or ON), and detection mode (PEAK or AVG). These three parameters are shared among the general demodulation, and ingress spectrum modes. Whenever they are changed in one mode, they are reflected upon entering another spectrum mode.

Set the parameters in this menu by pressing the function key for the parameter you want to change, and then use the knob to select the option desired. An arrow cursor to the left of the screen indicates which parameter is being edited.

Ingress Monitor Mode

RF noise, or ingress, in the return band of bi-directional cable systems raises the noise floor and reduces operating margins. High ingress levels can slow traffic down in the return band or even completely disrupt it, and ingress can be found throughout the cable system. Sources of ingress can be electrical consumer products, radio interference, poorly shielded cables, or oxidized connectors to name only a few.

The RF analyzer Ingress Spectrum Monitor mode is a specialized spectrum mode that allows you to effectively monitor the frequencies in the return band spectrum for ingress limit violations. You can define limit ranges and thresholds and leave the RF analyzer at a remote location to monitor ingress when it is not convenient for you to be there. Using the ingress spectrum mode jointly with the D/U measurement mode, you can identify the cause of poor D/U results.

To display the Ingress Spectrum Monitor mode press SPECT then press F3 (INGRESS MONITOR). You will see a display similar to Figure 3–21.

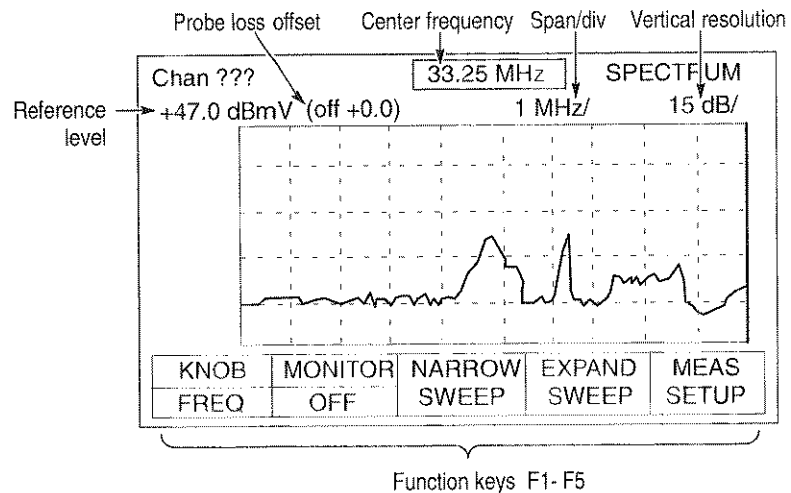

Figure 3–21: Ingress monitor display

Display. The ingress spectrum display is similar to the general spectrum display with three exceptions:

- Markers and marker readouts are not available
- Max hold is enabled through the measurement setup menu
- Ten horizontal divisions rather than eight are displayed

Narrow and expand sweep (F3 and F4) work identically to the general spectrum mode with markers off (see page 3-44, *Windowed Sweep*).

Ingress limits selection menu. When you first enter the ingress spectrum mode, the measurement defaults to the general purpose spectrum measurement characteristics. To set up the Ingress Monitor mode for monitoring, you need to define the window and amplitude threshold the instrument uses to detect the presence of ingress, and then define how to store the spectrum measurement when ingress violations are detected.

The RF analyzer detects ingress violations based on the parameters set in the New or Edit Ingress Limits Setup menu. To access either menu, use the following procedure:

1. From the Ingress Monitor display, press F5 (MEAS SETUP).
2. Press F5 (LIMITS SETUP). You will see the menu depicted in Figure 3-22. From right to left, the columns indicate the start frequency, stop frequency, amplitude threshold, and type of limit for each limit specified. In this case, only two MAX limits are specified and both are active.

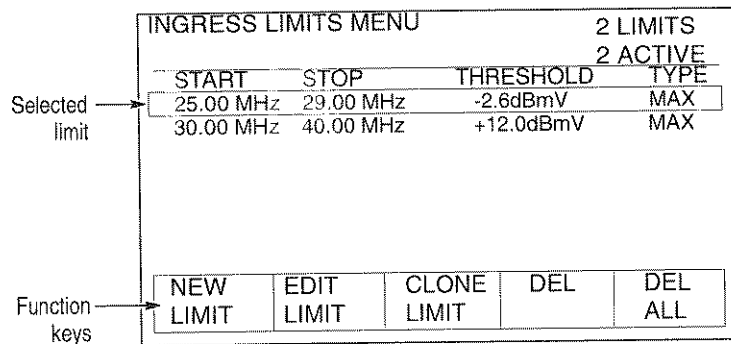

Figure 3-22: Ingress limits menu

3. Using the knob, scroll through the list to select a limit to edit or delete. The highlight box moves as you rotate the knob to indicate which limit is selected.
 - To delete a limit, select one with the knob and press F4 (DEL). You will be prompted to ensure that you want to delete the limit.
 - To delete all of the limits in the menu, press F5 (DEL ALL). Again, you will be prompted to ensure you want to delete all of the limits.
 - To clone limits (copy limits to another instrument), press F3 (CLONE LIMIT). See *Appendix B: Remote Communications* for information about communicating with another RF analyzer.

To edit or create a new ingress limit, continue with the procedure. Creating a new limit requires setting the same parameters as editing a limit. The rest of this procedure describes how to edit an existing limit, however, it also applies to creating a new limit.

4. Press F2 (EDIT LIMIT). The menu depicted in Figure 3–23 will be displayed.

EDIT INGRESS LIMIT MENU				
▶ Start Frequency:	<input type="text" value="25.00 MHz"/>			
Stop Frequency:	29.00 MHz			
Ampl Threshold:	-2.6 dBmv			
Type:	OFF	<input type="text" value="MAX"/>	MIN	
<input type="text" value="SET START"/>	<input type="text" value="SET STOP"/>	<input type="text" value="SET AMP"/>	<input type="text" value="SET TYPE"/>	<input type="text" value="ACCEPT ENTRY"/>

Figure 3–23: Edit ingress limits menu display

5. Select the parameter to edit using the function keys. An arrow cursor at the left indicates which parameter is selected to edit. A highlight box indicates which field is selected to edit.
6. Edit the fields using the knob or the keypad. Follow each keypad entry with MHz (for the start/stop frequencies) or ENTER for the amplitude threshold and type values. Use the knob for the Type parameter.

The Type option indicates whether or not the limit is active, and if it is, what kind of limit it is.

- OFF indicates that the limit is inactive.
- MAX indicates that any data point within the start/stop frequencies with an amplitude greater than that set in Amplitude is recorded as a maximum limit violation. Use MAX limits for identifying intermittent, “bursty” signals in the spectrum where known carriers do not exist. Up to 32 MAX limits can be active at a time.

NOTE. Whenever a MIN limit is defined, it is the only active limit. Only one MIN limit can be active at a time.

- MIN indicates that if all data points within the start/stop frequency range lie below the threshold set in Ampl. Threshold, a Min limit violation will be recorded and the spectrum waveform is immediately updated. (Waveforms are updated only for Min limit sweeps when a violation is recorded, Max violations continue the sweep.) Only one Min limit is recorded per sweep and only one Min limit can be active at a time. If a MIN limit is active, it is the only active limit. (MAX and MIN limits cannot be active at the same time.)

By using a Min limit threshold and max hold mode, the shape of any continuously present ingress under a time domain, multiple access (TDMA) carrier can be determined over time. Set the limit range to the edges of the carrier modulation envelope and the limit threshold to a value somewhat less than the peak amplitude. When the carrier is absent, the waveform is updated and the ingress underneath the carrier takes shape.

7. After you have completed editing the ingress limit parameters, press F5 (ACCEPT ENTRY). If you press ESC to exit the menu without accepting the changes first, you will be prompted to either discard or keep the changes.

Ingress monitor mode setup. After you have defined the ingress windows, amplitude thresholds and types of limits, you need to set up the following monitor mode parameters:

- The way in which the instrument reacts to ingress violations
- The way in which waveforms are stored when a violation is detected

To setup these Ingress Monitor mode parameters, use the following procedure:

1. From the ingress display, press F5 (MEAS SETUP). Set max hold, preamp, and peak detect as described in *Measurement Setup Menu* on page 3-48.
2. Press F4 (MONITOR SETUP). The menu displayed allows you to configure four ingress monitor parameters. Table 3-14 indicates the options available for each monitor mode parameter and provides a brief comment about each option.

Table 3-14: Ingress monitor mode parameters

Parameter	Options	Comments
Violation action (F1)	CONT	Continues making measurements after a violation is recorded.
	STOP	Stops making measurements once a violation is recorded.
	STORE	Stores the violation as a stored result and then continues making measurements. The information stored is determined by the Store action setting.
Store action (F2) ¹	ALL	The entire spectrum display is stored for each peak violation in the ingress limit range.
	ALL-NO-SPECTRUM	Same as ALL, except the spectrum waveform is not saved, only the violation information is stored.
	FIRST-VIOLATION-ONLY	Only the first violation per sweep is saved. Subsequent violations are tallied, but no violation information of these violations are recorded.
Audible alarms (F3)	OFF	No audible alarm is sounded.
	ON	Beeps whenever a violation is recorded.
Sweep delay (F4) ²	MINUTES	0 indicates that there should be no delay between sweeps. Non-zero indicates the integer number of minutes between the start of each measurement sweep. Valid parameters are 0 and 2-60. Use the knob or keypad to make this selection.

¹ When ALL is selected, up to 300 ingress records can be saved into the NVRAM of the RF analyzer. When ALL-NO-SPECTRUM is selected, up to 4500 records can be stored.

² The instrument enters the sleep mode between measurement sweeps when a non-zero delay time is specified.

Set the parameters in this menu by pressing the function key associated with the parameter you want to change, and then use the knob to select the option desired. An arrow cursor to the left of the screen indicates which parameter is being edited. Use the knob or the keypad to specify the value for SWEEP DELAY.

3. Press ESC to accept entries and exit the menu.

Ingress display. After you have set up the instrument to make ingress measurements, return to the ingress display. Press SPECT, and then press F3.

To begin making ingress measurements, press F2 (MONITOR).

The RF analyzer will begin making spectrum sweeps and will look similar to Figure 3–24 after a limit violation has occurred.

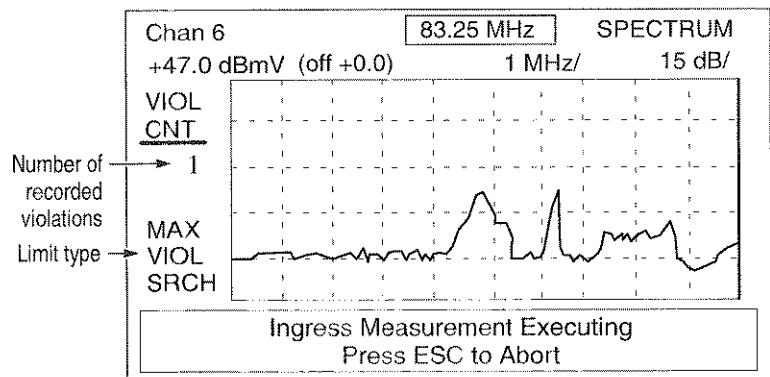

Figure 3–24: Ingress monitor violations display

The message at the bottom of the display indicates that the instrument is performing ingress measurements. If Sweep Delay is non-zero the instrument will go into the sleep mode in between sweeps. If Violation Action is set to STOP, the instrument stops sweeping after the sweep in which a violation was detected. Otherwise, the RF analyzer continues to make spectrum sweeps and updates the VIOL CNT value as it detects ingress violations. Records of the violations are stored in the NVRAM of the instrument

according to the parameters you set in the monitor mode setup menu (see Table 3–14 on page 3–54).

VIOL CNT indicates how many limit violations have been recorded for the current set of measurements. This number is updated once for every limit range that records a violation. It is reset when the monitor mode is exited or any key other than F2 is selected.

VIOL SRCH indicates the type of limits that are being checked (MAX or MIN).

During the ingress spectrum sweeps, only the ESC and POWER keys are enabled. The rest of the front panel is disabled.

Stored ingress violations. The ingress display does not use markers; however, when an ingress violation is detected and stored, the stored result displays three markers. Figure 3–25 shows a stored MAX ingress violation waveform with multiple violations for the selected record.

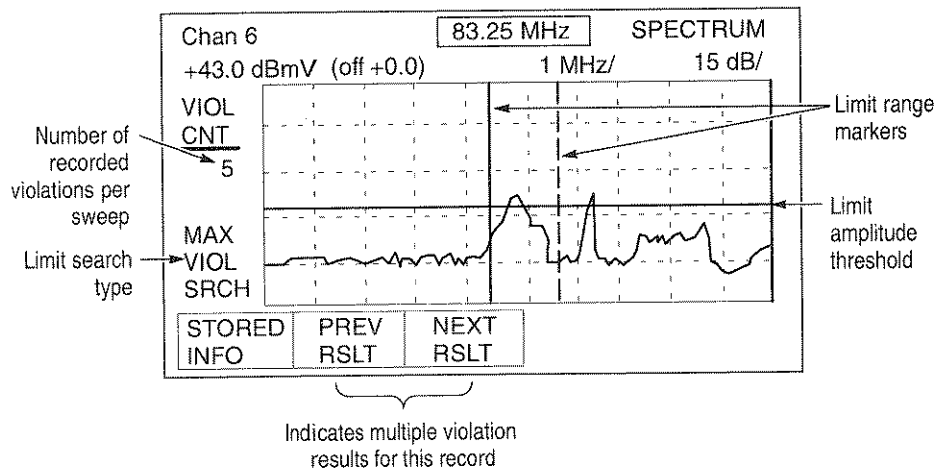

Figure 3–25: Stored ingress monitor waveform

Two vertical markers indicate the ingress limit frequency range for the violation detected. One horizontal marker indicates the limit amplitude threshold of the detected violation.

You can access subsequent and previous violation results by selecting NEXT RSLT and PREV RSLT respectively. PREV RSLT is not displayed for the first result in a record; similarly, NEXT RSLT is not displayed for the last result.

The VIOL. CNT value changes after all the violations for the sweep have been displayed and is moved by the number of violations detected for next sweep. For example, one interpretation of Figure 3-25 is that there were five detected violations for the first sweep in the record displayed, and the violation shown is either the second, third, fourth or fifth. The number of violations detected per sweep depends somewhat on the number and type of active limits. If only one MIN limit is active, only one violation is possible per sweep. However, if multiple MAX limits are active, many violations are possible per sweep.

In addition to the standard stored information, pressing F1 (STORED INFO) displays the following ingress violation information:

- Resolution bandwidth
- Preamp setting
- Detection mode
- Violation frequency and amplitude
- Level (dB) above or below the amplitude threshold

Sweep Mode

To access the sweep display, shown in Figure 3–26, press the front-panel SWEEP key. The instrument mode (SWEEP) is shown in the upper right corner of the screen.

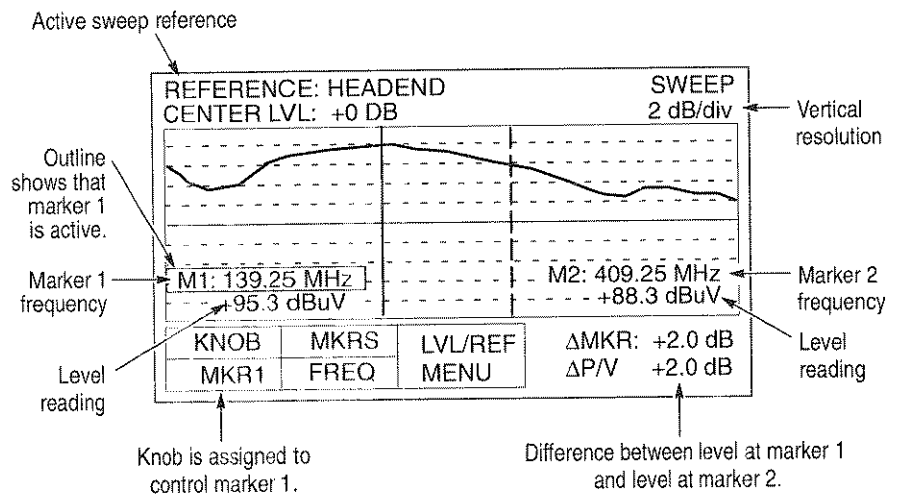



Figure 3–26: The sweep display

Table 3–15 defines the key actions that are effective for this mode.

Table 3–15: Functions of active keys in sweep display mode

Key	Action
Menu keys	Enters selected menu. (Aborts a partial keypad entry.)
Function keys	Assign knob to level, marker 1 or marker 2. Can enter the level/reference submenu. Override partial keypad entry.
Knob	Tunes the active marker or changes the center level. Overrides partial keypad entry.

Table 3–15: Functions of active keys in sweep display mode (continued)

Key	Action
Numeric keypad	Keying either channel or frequency, followed by CHAN, MHz, or ENTER, tunes the instrument.
CHAN	Terminates keypad entry as channel. Switches to channel entry mode.
MHz	Terminates keypad entry as frequency. Switches to frequency entry mode.
	Pressing backspace during a keypad entry erases the character preceding the cursor. Backspacing 1 click after field is empty aborts partial entry.
HELP	Displays context-sensitive help screen; aborts a partial keypad entry.
ESC	Exits the submenu or menu, one level at a time. Aborts a partial keypad entry without changing the instrument setup.

Markers. The sweep display has two tunable frequency markers. Readouts in the lower portion of the measurement screen show the marker 1 and marker 2 frequencies and the level (in dB) at those frequencies. Additionally, a readout in the lower right corner of the screen shows the difference between the markers and a peak-to-valley readout.

In addition to frequency and channel based marker modes, the Sweep display also allows you to turn the markers off. To turn the markers off press F3 (MKRS) until the on-screen label reads OFF. The markers and the marker readouts will be removed from the display and the knob is assigned to the center level. To replace the markers, press F3 again until either FREQ or CHAN is displayed. Pressing CHAN or MHz while the markers are off will display channel or frequency based markers respectively (along with the marker readouts).

A marker can be tuned only while it is active. Tune with the knob or by a keypad entry terminated with CHAN for channel and MHz or ENTER for frequency. Tuning is limited to frequencies that correspond to channels in the instrument's channel tables. Entering other frequencies will cause an error message, leaving the marker frequency unchanged.

Centering the trace. If the trace is off-screen, an arrow next to the CENTER LVL readout (upper left corner of the screen) indicates the direction of the trace position.

Pressing F1 (KNOB) until the on-screen display reads LVL assigns the knob to control the center level in 1 dB steps. Then, turning the knob will move the trace up and down on the screen. The CENTER LVL readout value at the top of the display will indicate the new center screen reference value.

Pressing F3 (LVL/REF MENU), then pressing F1 (CENTER TRACE) will center the trace on screen, and adjust the center level accordingly.

Vertical resolution. The resolution can be set to 1 dB or 2 dB per division. Select LVL/REF MENU, then select 2 dB/ or 1 dB/. The present setting is indicated below the instrument mode in the upper right corner of the display. See Figure 3-27.

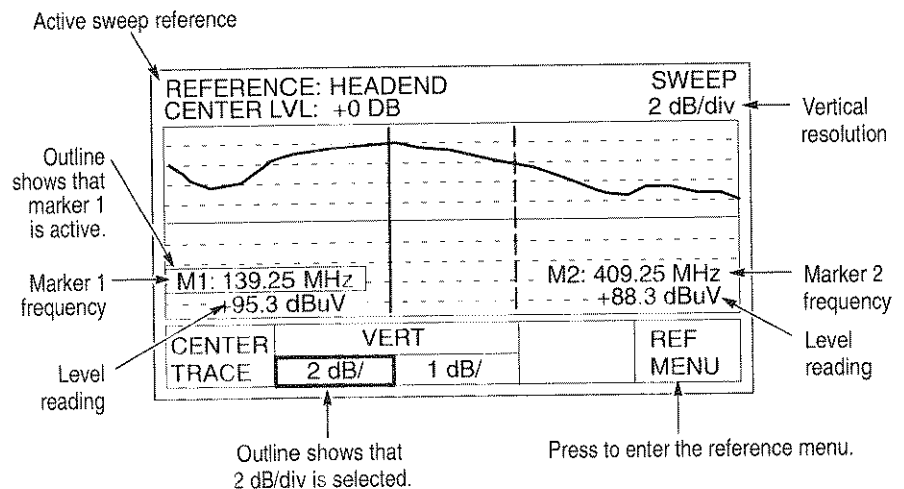

Figure 3-27: The sweep LVL/REF submenu display

Store a sweep reference. The results of 'all channel' measurements are used for the sweep references. For example, you can store an all channel mode record at the head end, and use it as a reference for field measurements.

Press LEVEL, then select ALL CHAN. This will make a measurement in the all channel mode. (The maximum signal level is 5 dB down from the reference level.) Then press SWEEP, and select LVL/REF MENU, followed by REF MENU. Select STORE NEW to add the most recent all channel mode measurement to the end of the list of stored sweep references (see Figure 3–28).

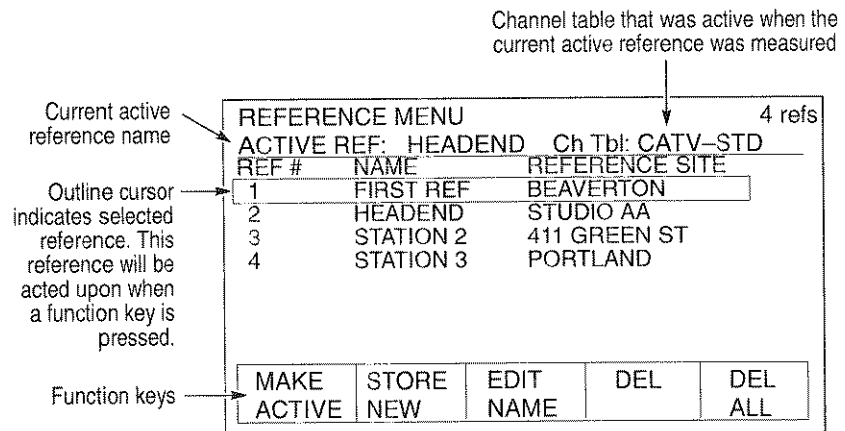

Figure 3–28: Reference menu

Select the active sweep reference. You can select any of the stored references to be active. The currently active reference appears above the list of references. To change this, turn the knob to select the reference that you will make active, then select MAKE ACTIVE. The selected reference will become the active reference, and it will now appear above the list. Press ESC to exit the reference menu. Now the sweep menu is displayed, and the reference that you have just selected will appear as the active reference in the upper left corner of the screen.

Measurement Reference

Configuration Reference

This section describes the measurement parameters and instrument configurations that you can set using the SignalScout RFM151 RF analyzer menu options. Before using this section, you should read *Getting Started* and *Operating Basics*.

Configuration Reference is organized alphabetically by topic name.

Channel Tables

The RF analyzer uses fixed and custom channel tables. Each instrument is loaded with the eleven fixed channel tables, which can be edited, but can not be deleted. These tables are defined in *Appendix A: Channel Tables*, with space allowed in the tables for you to write in modifications. A blank table is also provided for you to photocopy and document custom channel tables.

Channel numbers entered in measurement modes will be interpreted in terms of the active channel table. For example, in the 1 channel measurement mode, with CATV-STD channel table active and the instrument tuned to channel 2, the frequency will be 55.25 MHz.

Selecting the active channel table. Press UTIL, then select CHAN TABLE. The list of channel tables (Figure 3–29) is displayed. Use the knob to scroll to and select the channel table to become active, then press MAKE ACTIVE. The new active channel table will appear above the list of channel tables.

Editing Channel Tables

To edit channel tables, press the front-panel UTIL key, then select CHAN TABLE. A list of all channel tables that are loaded in the instrument will appear (Figure 3–29).

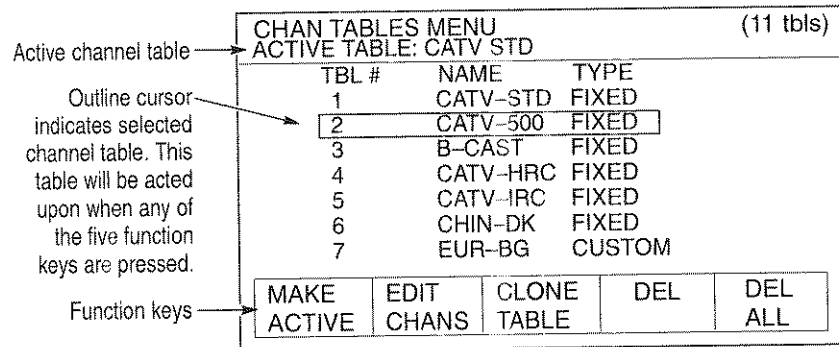

Figure 3-29: Channel tables menu

Use the knob to select the channel table to be edited, then select EDIT CHANS. This provides the edit channels menu display, shown in Figure 3-30, which allows editing of fixed or custom tables in the following fields: scrambled, amplitude offset, dwell time, and skip. (With the SignalScout application, additional fields can be edited.)

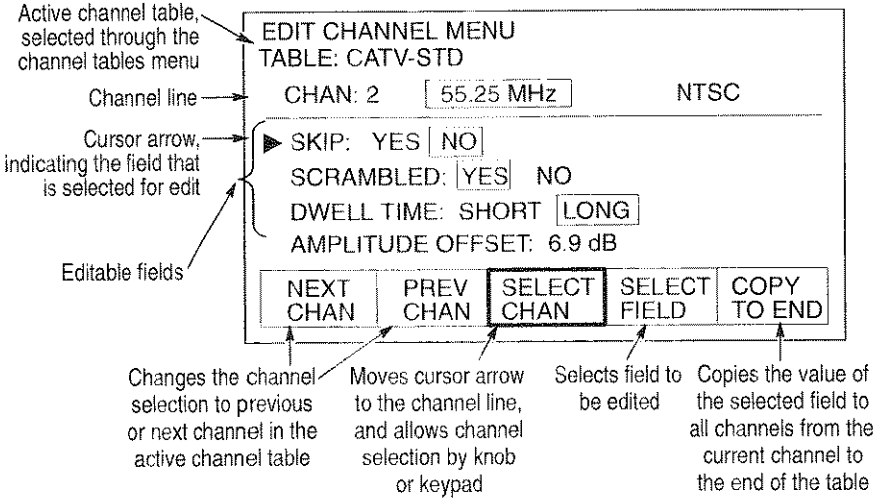

Figure 3-30: Editing channel tables

Table 3-16 defines all the fields that can be edited through this menu as well as those that are edited through the SignalScout CSS151 software.

Table 3-16: Channel table fields for editing

Field	Units	Range	Editing	Comments
Number	None	0-511	SignalScout application	Maximum of 200 total channels allowed.
Primary Freq	MHz	4.50-1080.00 (10 kHz min. resolution)	SignalScout application	Can be the analog visual carrier or the digital carrier.
Aural Offset	MHz	4.5, 5.5, 6.0, or 6.5 only	SignalScout application	Offset to the aural carrier (from visual carrier). N/A for digital channels.
Second Aural Offset	MHz	None, 4.72, 5.74, 5.85, or 6.55 only	SignalScout application	Offset to the second aural carrier (from visual carrier). N/A for digital channels.

Configuration Reference

Table 3-16: Channel table fields for editing (Cont.)

Field	Units	Range	Editing	Comments
Type	None	NTSC, PAL, SECAM, or DIGITAL only	SignalScout application	
C/N Bandwidth	MHz	0.1 to 25.5	SignalScout application	Bandwidth to normalize C/N measurements to.
Channel Edge	MHz	-327.6 to +327.6 (10 kHz min. resolution)	SignalScout application	Frequency offset from primary carrier to the channel edge (guard band). Used to locate the noise measurement point for in-service C/N measurement and for determining the lower edge of the modulation envelop for digital carriers.
Scrambled	None	Yes/No	SignalScout application or RF analyzer	Allows tracking of which channels are scrambled. Enabling scrambling also forces dwell time to LONG.
Amplitude Offset	dB	-12.5 to +12.5	SignalScout application or RF analyzer	Value added to absolute carrier level measurements. Usually used to correct for scrambled channel levels.
Dwell Time	None	Short/Long	SignalScout application or RF analyzer	Time to dwell at visual and aural carriers to get level reading: short for NTSC/PAL, long for SECAM and some scrambling types. N/A for digital channels.
Skip	None	Yes/No	SignalScout application or RF analyzer	If yes, channel is skipped in all channels and sweep mode.

Select channel. Channel tables are edited one channel at a time. To change the channel being displayed/edited, select SELECT CHAN. The arrow cursor will move up to the channel line, and the channel

number can be tuned with the knob or by keypad entry followed by CHAN or ENTER. You can only tune to channels that are stored in that channel table. If other entries are attempted, an error message is displayed and the present channel does not change.

Select field. In the edit channel menu, an arrow cursor along the left side of the screen indicates the selected field. This field can be edited with the knob (or keypad for amplitude offset). To change the selected field, select SELECT FIELD, repeating as necessary to reach the desired field.

Copy to end. Selecting COPY TO END copies the value of the selected field (indicated by the arrow cursor position) to all channels from the current channel to the end of the table. After the key is pressed, a confirmation screen will appear. You must select YES to copy. To return to the edit channels menu without copying, select NO or press ESC.

Deleting Channel Tables

Only custom channel tables can be deleted. If you attempt to delete a fixed channel table, an error message will be displayed and the table will not be deleted. Stored measurement results are dependent on the channel table that was active when they were stored. When you delete a channel table, be sure there are no records dependent on that table. If there are, they will be labeled as “orphans.”

Delete a (custom) channel table. Press the front-panel UTIL key, then select CHAN TABLE. A list of all channel tables that are loaded in the instrument will be displayed, with the selected table outlined. Use the knob to select the table that will be deleted, then select DEL. A confirmation screen will appear. Select YES to delete. To cancel the request, select NO or press ESC.

Delete all (custom) channel tables. Press the front-panel UTIL key, select CHAN TABLE, then select DEL ALL. A confirmation screen will appear. Select YES to delete. To cancel the request, select NO or press ESC.

Exit. Press ESC to exit the menu, one level at a time.

Importing Channel Tables

Channel tables can be imported from another SignalScout RF analyzer or from a PC. The number of channel tables that can be stored is limited only by the instrument's available non-volatile memory. Note that adding channel tables reduces the available non-volatile memory.

Using the SignalScout CSS151 software. A fixed table can be used as the basis for creating a custom table. Custom channel tables are created with the companion software, SignalScout application; refer to the *SignalScout CSS151 Software User Manual* for instructions.

Using another RFM150/1. Connect the two instruments according to the instructions on page B-1. With the source instrument, press the front-panel UTIL key, then select CHAN TABLE. A list of all channel tables that are loaded in the instrument will be displayed, with the selected table highlighted by an outline cursor. Using the knob, select the channel table that will be sent. Select CLONE TABLE. The table will now be sent to the destination RF analyzer and placed at the end of the list of tables. To display this list on the destination instrument, press UTIL, then select CHAN TABLE. Use the knob if needed to scroll. To edit or delete the table, select EDIT CHAN or DEL.

Exit. Press ESC to exit the menu one level at a time.

Clock

The clock determines the date and time that will be associated with a stored measurement result. It is also used to begin timed sequences, such as the 24 hour test. To display the clock menu (Figure 3-31), use the following key sequence: UTIL-F1 (INST CONFIG)-F2 (CLOCK). To select a field for edit, press the corresponding function key. An arrow points to the selected field.

The HOUR, MINUTE, and YEAR fields can be edited either with the knob or with the keypad followed by ENTER. A partial keypad entry can be aborted by pressing ESC or by backspacing. In the hour and minute fields, enter the current time using a 24-hour day.

HOUR can be 00 to 23, and MINUTE can be 00 to 59. In the YEAR field, enter the current year as a four-digit number (1994 through 2025).

The DAY OF WEEK field has an outline cursor showing the current setting. Turn the knob left or right to select the correct day, and the outline cursor moves to show the new choice. The DAY-MONTH field is controlled by turning the knob to select the correct date.

Exit. After you have finished making changes, press ESC to exit the menu one level at a time. The new settings will be saved.

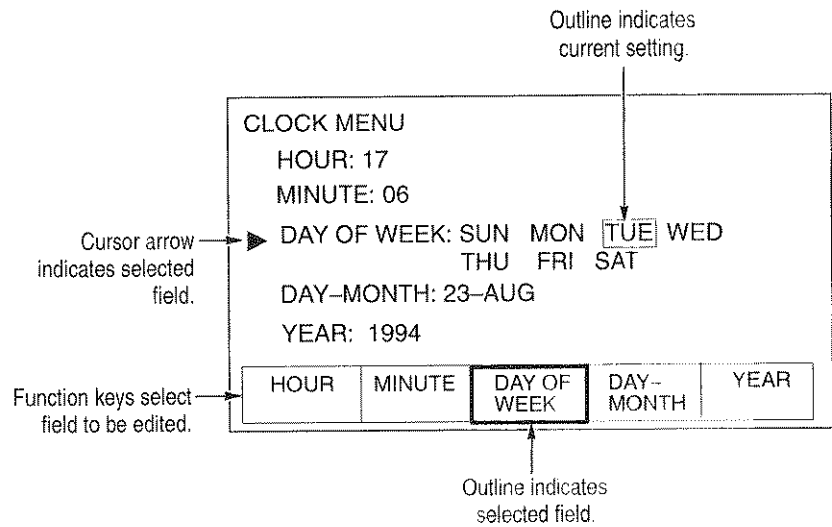

Figure 3-31: The Clock menu

Clone Configuration

A quick way to configure an instrument is to copy the configuration of another SignalScout RF analyzer.

Enter the RS-232 menu using the following pathway:
UTIL–F1 (INST CONFIG)–F1 (INTERFACE CONFIG)–F1 (RS232).
Make sure the RS-232 parameters on both instruments are set up the same. Connect the supplied RS-232 cable between the two instruments.

On the source instrument, press UTIL, followed by F1 (INST CONFIG), then F5 (CLONE CONFIG). The following instrument parameters will be sent to the destination instrument:

- Active channel table
- Active site name
- All Channel marker mode
- All Channel reference level
- Backlight mode (on/off)
- Center level for sweep mode
- Center level sensitivity (1 dB/2 dB) for sweep mode
- C/N mode
- C/N noise offset frequency
- Current measurement frequency and channel
- Digital/Analog Δ mode
- Digital/Analog Δ manual channel number
- Detection (average/peak) for meter and spectrum modes
- Field Strength attenuation, RBW, sensitivity, and volume settings
- Fundamental hum frequency
- High and low pilot frequencies
- Ingress sweep delay, and storage, violation, and alarm modes
- Measurement mode currently selected
- Meter mode speaker volume and demod mode
- Power down mode
- Power units
- Power up mode
- Preset labels and frequencies
- Probe loss
- Reference for all channels, meter, and spectrum modes
- Resolution bandwidth (RBW) for meter mode
- Screen contrast level

Screen contrast mode (manual/auto)
Span for spectrum mode
Spectrum volume, noise marker BW, vertical scale, and demod,
marker, maxhold, and preamp modes
Temperature units

Display Adjustment

The front-panel LCD screen provides measurement and menu displays. Through the DISP menu, the display can be adjusted for optimal viewing under different conditions.

To adjust the display, press the front-panel DISP key. The function keys will be assigned to backlight, contrast mode, and contrast.

Selecting BACK LIGHT moves the arrow cursor to BACKLIGHT. The present condition (ON or OFF) will be outlined. Turning the knob will toggle the backlight condition between ON and OFF. It may be desirable to turn the backlight on under low ambient light conditions.

Selecting CNTRST MODE moves the arrow cursor to CONTRAST MODE. The selected condition (MANUAL or AUTO) will be outlined. Turning the knob will toggle the contrast mode between MANUAL and AUTO.

The auto mode continually adjusts the display for optimum contrast under varying ambient temperature conditions.

The manual mode is used by selecting CNTRST, then using either the knob or keypad to select a contrast value between 0% and 100%. If the instrument is set to auto mode when a contrast value is selected, it will automatically switch to manual mode.

Executing Sequences

A series of measurements can be made by executing one of the automated measurement sequences that are loaded in the SignalScout RF analyzer. The results of the measurements will be stored, and can be accessed through the store menu. (To create or import a sequence, refer to page 3-86, *Adding and Deleting Sequences*.)

24 hour test. There are two 24 hour test sequences provided by the SignalScout RF analyzer that cannot be deleted: 24HOUR and 24HRV+A. The 24HOUR sequence uses the all channel mode. 24HRV+A uses the one channel mode and should be used when you need aural carrier measurements for your 24 hour test sequence. Both sequences are set to make measurements once every 6 hours, with 4 iterations. The measurement results will be tagged with the date and time, and automatically stored as SEQUENCE type.

Creating and editing sequence parameters. Press the front-panel SEQ key and the Sequence menu similar to Figure 3-32 is displayed. Use the knob to scroll to and select the desired sequence from the list. You will see the two factory installed sequences, followed by the sequences loaded into the RF analyzer NVRAM by another instrument or the SignalScout CSS151 software software.

Total number of sequences stored in the instrument → 17 seq

SEQUENCE MENU									
SEQ #	NAME	# OF TIMES	DELAY						
1	24HOUR	4	6						
2	24HRV+A	4	6						
3	SEQ1	5	1						
4	SEQ2	3	1						
5	SEQ3	4	1						
6	TEST1	5	1						
7	TEST2	4	1						
8	TEST3	2	1						
<table border="1" style="width: 100%; text-align: center;"> <tr> <td>EXEC</td> <td>CLONE SEQ</td> <td></td> <td>DEL</td> <td>DEL ALL</td> </tr> </table>					EXEC	CLONE SEQ		DEL	DEL ALL
EXEC	CLONE SEQ		DEL	DEL ALL					

Outline cursor indicates selected sequence. This sequence will be acted upon when a function key is pressed.

Function key labels

Figure 3-32: Sequence menu

Use the following procedure to create or edit one of these sequences:

1. Select EXEC. The Execute Sequence submenu will appear. See Figure 3–33.

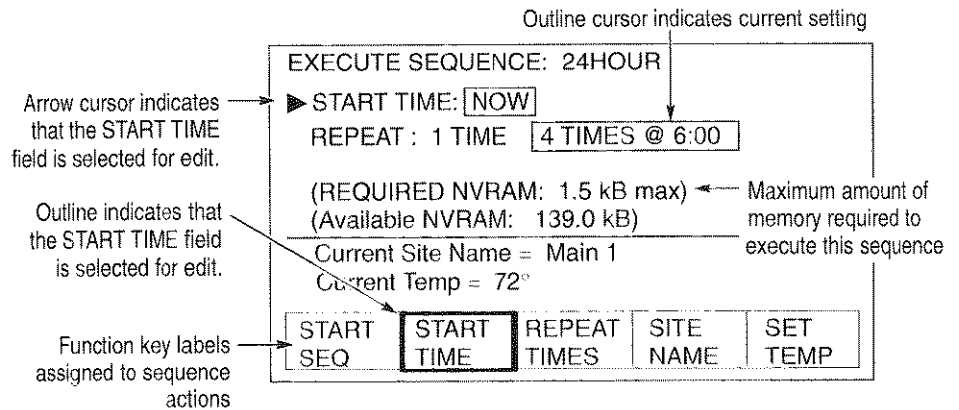

Figure 3–33: Execute sequence menu

2. Press F2 to select START TIME, and use the knob to select NOW, or the programmed time. The programmed time is set by the SignalScout application. (See the *SignalScout CSS151 Software User Manual* for information on creating custom measurement sequences.)
3. Press F3 to select REPEAT TIMES, and use the knob to select REPEAT: 1 TIME, or the programmed number of sequence iterations and repeat interval. The programmed number of iterations and repeat interval is set by the SignalScout application.
4. If you need to edit the site name and/or temperature, press F4 or F5 respectively. The Site Name or Set Temperature menu will be displayed and you can edit these values as necessary.
5. Press ESC to return to the Execute Sequence menu.

6. Ensure that the instrument is setup to make measurements and that the channel table used to create the sequence is loaded into the RF analyzer without modifications.
7. Press F1 (START SEQ) to start the measurement sequence.

When you select START SEQ, the RF analyzer attempts to load the channel table associated with the sequence as the active channel table, and present a confirmation screen. If that channel table is not available, or has been modified, an error message is displayed, and the sequence is aborted.

If the start time is NOW, the sequence begins immediately. If the start time is other than NOW, the SignalScout RF analyzer enters a sleep state until the start time.

Interrupting a sequence. While the instrument is in a sleep state, press the POWER key. A menu screen will give you the opportunity to stop the sequence and return to the normal operating mode or exit the message screen without stopping the sequence.

Viewing / archiving the measurement results. To view the sequence results after it has completed, press STORE and select RSLTS MENU. Use the knob to scroll to and select the first record created by the sequence. It can be identified by the word SEQUENCE in the TYPE column, and by the date and time displayed next to it. To view a the record, select VIEW. To archive the sequence results using the SignalScout application and a computer, refer to the *SignalScout CSS151 Software User Manual*.

Help

The SignalScout RF analyzer is equipped with context-sensitive help screens. If you require additional information after reading the help screen, look up the subject in the alphabetical index at the end of this manual.

Organization of Help Screens

During normal instrument operation, measurements or configuration parameters appear on the top portion of the screen. Function key labels (if any) appear across the bottom of the screen. The help screens follow that organization.

Each help screen describes the upper and lower portions of the screen that were displayed at the time HELP was pressed. Help for the top portion of the screen appears first (Mode Help). Turning the knob will scroll to help for the bottom portion of the screen (Function Keys Help).

Note that combinations sometimes occur, such as having 1 channel measurement mode displayed on the top portion of the screen, and the store menu displayed across the bottom. In this case, the help screen would consist of Mode Help for 1 channel mode, followed by Function Keys Help for the store menu.

Using the Help Screens

Help screens are accessed by pressing the front-panel HELP key. Note that pressing HELP can abort a partial keypad entry in some modes.

Mode help. Help for the top portion of the screen is referred to as Mode Help. For example, if HELP is pressed during 1 channel mode operation, the help screen that will appear is entitled: "1 Channel Mode Help."

Immediately below the title are reminders to use the knob to scroll to additional lines of help and to press ESC to exit the help screen.

The remainder of the information in the Mode Help tells you how to use the instrument mode that was displayed when HELP was pressed. When you are instructed to perform a key or knob action, you must first exit the help screen by pressing the ESC key.

Configuration Reference

Use the knob to scroll through all lines of Mode Help, then continue on to the Function Keys Help, if there is a function key assignment for that display.

Function keys help. After scrolling past the Mode Help, the title for the function keys portion of the help screen will appear. For example, the title for the store menu will be “Store Function Keys Help.” This portion of the help screen will describe the action of the function keys (F1 through F5). When you are instructed to perform a key or knob action, you must first exit the help screen by pressing the ESC key.

Exit. When you are finished with the help screen, press the ESC key to exit.

Power Mode

The SignalScout RF analyzer has three basic power modes: on, off, and sleep. Table 3–17 gives the possible combinations of instrument state and power switch actions.

Table 3–17: POWER key modes

State	Event	Destination State
OFF	POWER key is pressed	ON
ON	POWER key is pressed	OFF
	Timeout (no activity for 10 minutes when operating off of the battery)	OFF
	Select sequence with delayed start time	SLEEP
	Loss of power	OFF
SLEEP	POWER key is pressed	QUERY
	Programmed repeat of the sequence	ON
QUERY	ABORT	ON
	Do not abort	SLEEP
	Timeout (no activity for 10 minutes)	SLEEP

Sleep state. During automated sequences and in between sweeps for ingress monitoring, the instrument waits for the scheduled time to begin a measurement. This waiting mode is called the sleep state. If the instrument is in a sleep state, pressing POWER displays a query screen similar to the one shown in Figure 3–34. You have the option of canceling the next scheduled measurement or returning to the sleep state.

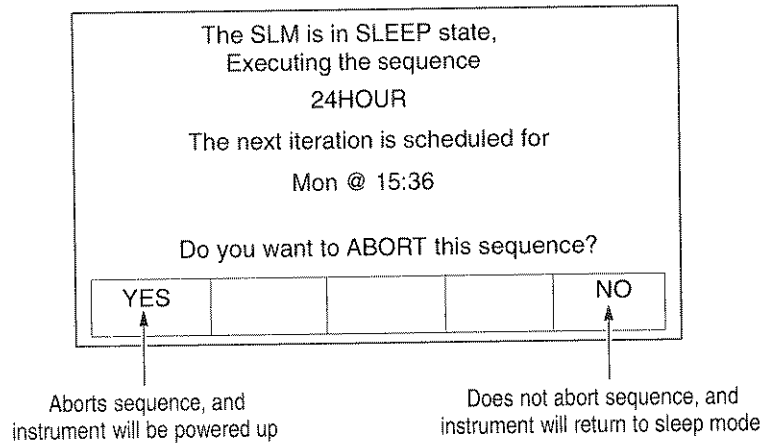

Figure 3–34: The sleep state query screen

After performing a scheduled measurement sequence, the instrument will either power down or return to the sleep state to wait for the next sequence or ingress spectrum sweep.

Power Up / Power Down Modes

You can configure the power up and power down modes of the SignalScout RFM151 RF analyzer.

Power up mode. The RF analyzer can be set to power up in any of the 10 measurement modes, or in the last measurement mode that was used before power down. When auto power down is enabled, LAST is useful because the instrument will power up in the same mode.

Battery auto power down. If this feature is enabled and you are operating off of battery power, the instrument powers down after 10 minutes with no activity, to preserve battery life.

Changing the modes. Press UTIL., then select INST CONFIG followed by PWR UP/DN. The power up / down parameters are displayed (Figure 3–35).

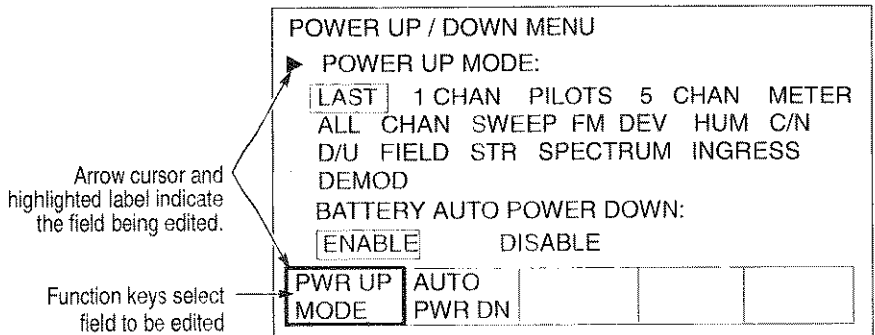

Figure 3–35: The power up / down menu

Press F1 or F2 to select the field, then turn the knob to change the setting. The outline cursor moves to the new setting.

Exit. Press ESC to exit the menu one level at a time. The new settings will be saved.

Powering Up From an AC Source

Use only the AC adapter that is supplied with the RF analyzer. When powering up the instrument, follow this sequence to ensure proper operation under all conditions:

1. Attach the AC adapter to the RF analyzer power input connector.
2. Connect the adapter plug to an appropriate AC power source (see Table 4-2 on page 4-7 for power source requirements).
3. Press the front-panel POWER key to turn on the RF analyzer. A beep will signal that the instrument is initializing, and the software version will be displayed momentarily.
4. Connect the television signal to the RF input on the RF analyzer, and proceed with normal instrument operation.

Presets

There are five presets, corresponding to the five function keys, which are available to tune the instrument in certain measurement modes, such as 1 channel mode. The preset labels are displayed along the bottom of the screen.

To tune the instrument to a preset frequency, press and release the function key below the desired on-screen label. When the key is pressed, the channel and frequency readouts in the top line of the display will change, and the function key label is highlighted. Any other function keys set to the same frequency will also be highlighted. A function key label will be highlighted even if you tune to its preset frequency using the knob or keypad.

You can define the on-screen labels that will be displayed when the presets are available, and you can choose the frequencies to which the instrument will be tuned when one of those keys is pressed.

You can also set the preset to auto, allowing its preset channel and frequency to be programmed by the press-and-hold method. When auto is used, the on-screen labels will be controlled by the instrument.

While the preset key assignments are displayed, pressing another menu key displays the new menu. ESC has no function.

Editing the Presets

Press the front-panel UTIL key, then select MSMT CONFIG and ASSIGN PRESET. A list of the five presets will be displayed (Figure 3–36). Use the knob to select the preset to be edited. (The selected preset will be indicated by an arrow cursor along the left side of the screen.)

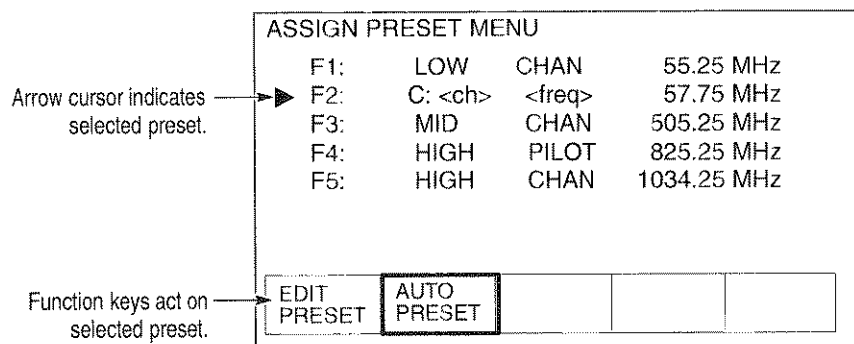

Figure 3–36: Assign preset menu

To edit the preset, select EDIT PRESET. An editing menu similar to Figure 3–37 will be displayed.

An arrow cursor along the left side of the screen indicates the selected field. Use the function keys to select the field to be edited: **TOP LABEL** (the top line of the on-screen label), **BOTTOM LABEL** (the bottom line of the label), or **FREQ** (frequency to which the preset will tune the instrument). Edit the fields as desired, using the standard editing techniques. Refer to *Editing Methods* on page 2–9.

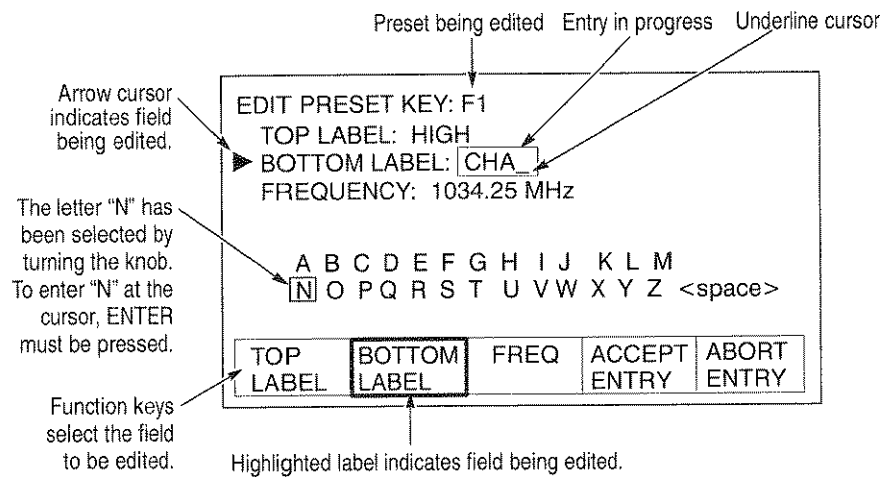

Figure 3–37: Editing Preset F1

Auto Preset / Press-and-Hold Programming of Presets

To set the preset to auto, select AUTO PRESET. Internally generated auto channel/frequency labels will replace the previous labels for this preset. See F2 in Figure 3–36.

If a preset has been set to auto, it can be programmed with the press-and-hold method, as follows.

1. Enter a mode that has presets available, such as 1 channel mode. The five presets appear along the bottom of the screen; choose the preset you want to program, and locate the function key (F1–F5) that is assigned to it.
2. Use the knob or keypad to tune the instrument to the desired channel or frequency, then press and hold the chosen function key until the instrument beeps (about 3 seconds).
3. When the preset is programmed, the on-screen channel / frequency label will change automatically. If you release the key before the instrument beeps, it will not be programmed; it will tune the instrument as usual.

Printing

You can print measurement results through the SignalScout application and a PC, or through a direct hookup between the SignalScout RF analyzer and a printer. The following paragraphs describes how to print directly from the RF analyzer to a printer.

Printer formats

The line length is limited to 40 characters to ensure compatibility with portable, battery-operated printers. although traditional line printers can also be used. Printers supported by the RF analyzer include the following:

- **TEK DPU-411.** This format option can be used with any Tektronix hand-held printer and any Seiko DPU-411 printer.
- **Epson FX.** This format option can be used with any Epson compatible printer.
- **Encapsulated Postscript (EPS).** This format option works with EPS (version 1.2) compatible printers and Adobe postscript printers (version 2.0).

Printing

Before printing, connect to the printer using the RS-232 interface and configure the printer interface parameters as shown in *Appendix B: Remote Communication*.

NOTE. *The printer interface parameters that you set are automatically in effect while the direct print job is in process. When the print job is complete, the SignalScout RF analyzer returns to the interface parameters that you set in the UTIL-RS232 menu.*

To print a measurement result press ESC until the instrument beeps (about three seconds).

Auto Power Down

Auto power down will not occur while a direct print job is in process. If enabled, auto power down will occur after 10 minutes of no instrument activity, including printing.

Error Messages

If you try to print a screen while another print process is in process, you will be given the opportunity to stop the current process or cancel the new print process. Pressing F5 (NO) at the query displayed in Figure 3-38 will cancel your new print command. Pressing F1 (YES) will cancel the print process in progress.

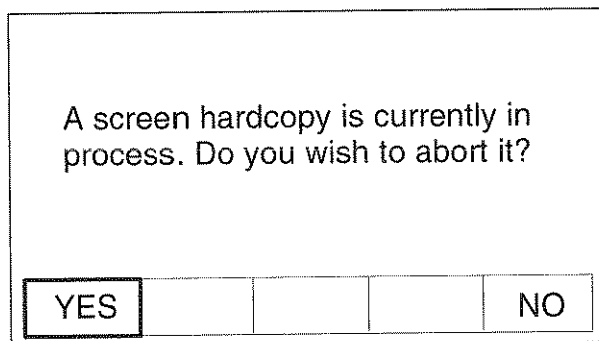

Figure 3-38: Hardcopy in process

Probe Loss

The offset value for probe loss can be set through the measure setup menu as follows:

Press UTIL, select MSMT CONFIG, then MSMT PARAMS. An arrow cursor along the left edge of the screen, as well as a highlighted function key label, will indicate the field that is presently selected for edit. If probe loss is not already selected, press the corresponding function key (F1) to select probe loss for edit. Probe loss can be entered using either the knob or the keypad.

Using the keypad. If using the keypad, ENTER must be pressed following the entry. A partial keypad entry can be cancelled by pressing ESC or backspacing one space past an empty field. This will restore the previous frequency.

Using the knob. The knob changes the value in increments of 0.1 dB. A knob entry is not cancelled by pressing ESC.

Exit. When you have finished making changes, press ESC to exit the menu one level at a time.

Sequences (Adding and Deleting)

Sequences are automated routines that can perform tests at programmed times. The number of sequences that can be stored is limited only by the instrument's available non-volatile memory; adding sequences reduces that memory. Executing sequences is described in the *Making Measurements* section on page 3-72.

Adding Sequences

24 hour test. Two 24 hour test sequences are installed in the RF analyzer at the factory and can not be deleted. One of the sequences uses the All Channel measurements (24Hour). The other sequence (24HRV+A) uses 1 Channel measurements and should be used when you need aural carrier measurements as part of your 24 hour test sequence. For both of these installed sequences, the repetition number is four and the delay between sequences is six hours.

Using another RFM151. Connect the two instruments, using the instructions in *Appendix B*. On the source instrument, press SEQ to display the list of sequences as shown in Figure 3-39.

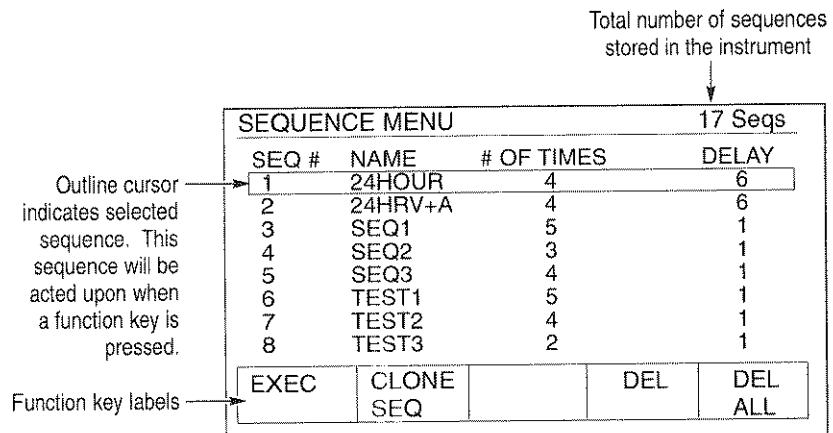

Figure 3-39: Sequence menu

Turn the knob to select the sequence to be sent, then select CLONE SEQ. The sequence is sent to the destination SignalScout RF analyzer and placed at the end of the list of sequences. To display this list on the destination monitor, press SEQ. Use the knob to scroll if needed.

Using the SignalScout CSS151 software. Predefined sequences can easily be selected and imported to the SignalScout RF analyzer, and other sequences can be quickly set up by turning fields on or off with the mouse. Refer to the *SignalScout CSS151 Software User Manual* for instructions.

Deleting Sequences

Delete all. To delete all sequences stored in the instrument, press SEQ, then select DEL ALL. A confirmation screen will appear; select YES to delete all sequences. Selecting NO or ESC will cancel the request.

Delete a selected sequence. To delete a specific sequence, press SEQ, then turn the knob to highlight the desired sequence. Select DEL. A confirmation screen will appear; select YES to delete the selected sequence. Selecting NO or ESC will cancel the request.

Exit. Press ESC to exit the menu one level at a time.

Site Name

The results of measurements made with the RF analyzer can be stored in the internal non-volatile memory. The active site name is attached to results as they are stored.

Selecting the active site name. Press STORE, then select SITE NAME. A list of site names will be displayed (Figure 3–40). Use the knob to select the site name to become active, then select MAKE ACTIVE. The new active site name appears above the list.

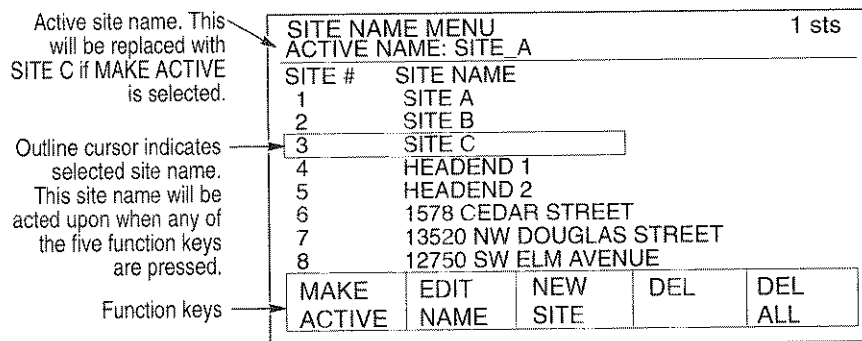

Figure 3–40: Site name menu

Site name. Press STORE, then press F3 (SITE NAME). If you are entering a new site name, select NEW SITE (F2). If you are editing an existing site name, use the knob to select the name to be edited, then select EDIT NAME (F3).

After selecting either EDIT NAME or NEW SITE, a screen similar to the one shown in Figure 3–41 is displayed. Enter or edit the site name. A site name can contain numbers and letters up to 20 characters. New site names are added to the end of the list of site names. The number of site names that can be stored is limited by the amount of available non-volatile memory.

Figure 3–41: Edit site name menu

Delete a site name. Press the front-panel STORE key, then select SITE NAME. A list of all site names that are stored in the instrument will be displayed. Using the knob, highlight the site name that will be deleted. Select DEL. A confirmation screen will appear. Select YES to delete. To cancel the delete request, select NO or press ESC.

Delete all site names. To delete all site names, press the front-panel STORE key, then select SITE NAME. Select DEL ALL. A confirmation screen will appear. Select YES to delete all site names. To cancel the delete request, select NO or press ESC.

Note that stored measurement results are tagged with a site name. As a site name is deleted, the site information will also be deleted from any stored measurement records that were tagged with that site name.

Exit. Press ESC to exit the menu one level at a time.

Stored Measurement Results

The results of measurements made with the RF analyzer can be stored in intermediate non-volatile memory. Some of these results can be downloaded to a computer, using the companion SignalScout application. The following list indicates the measurements that can be downloaded to the one of the SignalScout applications:

- One channel (Site Worksheet)
- All channel (Site and Sweep/All Channel Worksheet)
- C/N (Site Worksheet)
- Hum (Site Worksheet)
- FM Deviation (Site Worksheet)
- D/U (Site Worksheet)
- Sweep (Sweep/All Channels Worksheet)
- Spectrum (Spectrum/Ingress Worksheet)

Store a measurement result. After making a measurement, press STORE, then select STORE RSLT. This stores the most recent measurement result from the current measurement mode. The result is numbered, time and date stamped, and stored at the end of the list of stored measurement results. The message, "Operation Complete," will appear briefly to indicate that the record has been stored.

View a measurement result. Press STORE and select RSLTS MENU. A list of all stored measurement results will be displayed (Figure 3-42). Use the knob to highlight the desired measurement result. The list will scroll as you turn the knob, if needed.

STORED RESULTS MENU				7 recs
REC	TYPE	DATE	TIME	
1	1 CHAN	29-JUN-94	09:54	
2	1 CHAN	29-JUN-94	10:01	
3	METER	30-JUN-94	13:15	
4	METER	30-JUN-94	13:21	
5	ALL CHAN	02-JUL-94	08:37	
6	C/N	02-JUL-94	08:42	
7	C/N	03-JUL-94	08:23	
VIEW			DEL	DEL ALL

Outline cursor indicates selected measurement result. This result will be acted upon when one of the function keys are pressed.

Function keys

Figure 3-42: Results menu

Select VIEW to view the highlighted measurement result. The display will change to show the recorded result as it was displayed when the measurement was made.

If the viewed result is part of a sequence of measurement results, or if it is part of an ingress spectrum result, selecting NEXT RSLT (F3) will display the next recorded result. Then, selecting PREV RSLT (F4) will display the previous result. F4 is unassigned for the first result in a sequence or ingress violation result; F3 is unassigned for the last result. Pressing ESC will exit the view screen.

Additional Stored Information menu. From the stored result display, selecting STORED INFO (F1) displays additional information about the measurement, such as the site name and temperature (see Figure 3-43).

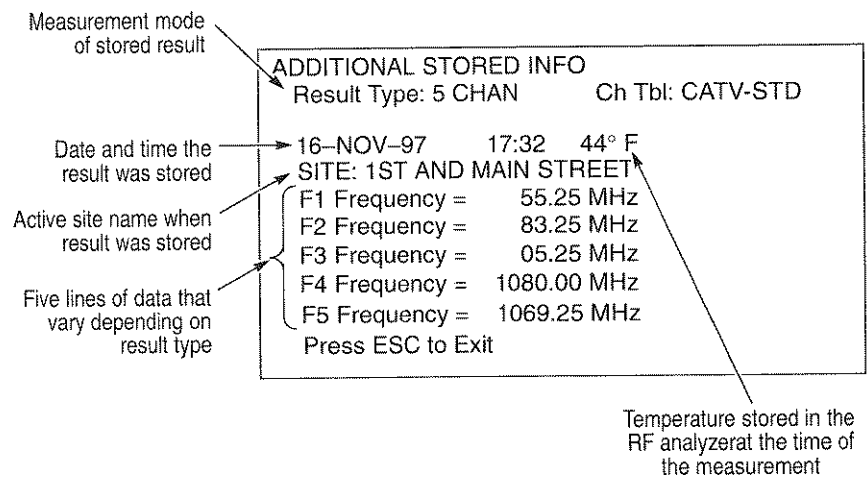

Figure 3-43: Additional information screen for 5 channel measurement type

If the stored result is part of a sequence, the repetition number is also displayed. If the stored result is an ingress spectrum result, the violation level and frequency is displayed. Furthermore, the number of dB the violation exceeded the limit (for maximum violations), or failed to meet the limit (for minimum violations), is also displayed. For minimum violations this number will be negative, for maximum violations it is positive. Pressing ESC will exit the additional stored information screen.

Delete all stored measurement results. Press STORE and select RSLTS MENU, then press F5 (DELETE ALL) to delete all stored results. A confirmation screen will appear. Select YES to delete all results. NO or ESC cancels the request without making any deletions.

Delete a selected measurement result. Press STORE and select RSLTS MENU to enter the results menu. A list of all stored measurement results will be displayed (Figure 3-42). To delete the result, select the desired measurement result with the knob, then press F4 (DELETE). A confirmation screen will appear. YES deletes the result. NO or ESC cancels the request. When a result is deleted, the list is automatically compacted and the records are renumbered.

Temperature

Stored measurement results are tagged with a user-entered temperature. To enter the temperature menu, press STORE, then select SET TEMP. The two editable fields are displayed (Figure 3-44), with the arrow cursor pointing to the field that is selected for edit.

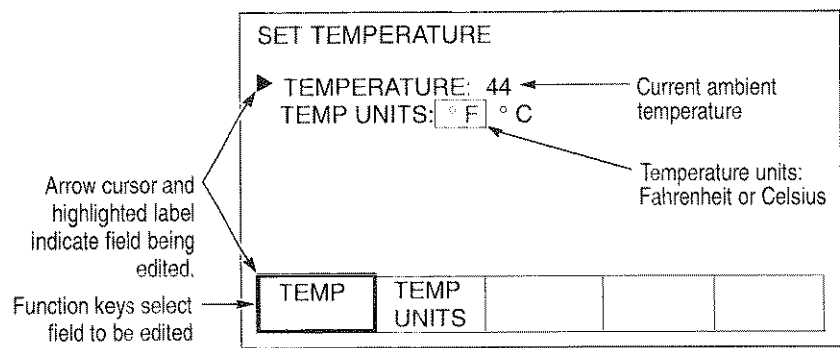

Figure 3-44: Set Temperature menu

Temperature units. Press F2 to select the temperature units field, then turn the knob to toggle between degrees Fahrenheit and degrees Celsius, with the outline cursor indicating the current selection.

Temperature. Press F1 to select the temperature field, then enter the present ambient temperature, either with the knob, or by keypad entry followed by ENTER. A partial keypad entry can be aborted by pressing ESC or by backspacing one click after the field is empty.

Exit. When editing is complete, press ESC to exit the menu one level at a time. The new settings will be saved.

Units

The power units can be set to dBmV or dBuV. This determines the readout units for the level measurements in the measurement modes.

To change the power units, press UTIL and select MSMT CONFIG, followed by MSMT PARAMS. The function keys will be assigned to the two fields available for edit in this mode. An arrow cursor along the left edge of the screen, as well as a highlighted function key label, indicate which field is selected for edit.

Press F2 to select power units for edit. The present setting for power units is indicated by an outline cursor. Turning the knob back and forth toggles the setting between dBmV and dBuV.

Exit. After editing the level units as desired, press ESC to exit the menu one level at a time. The new setting will be saved.

Specifications

This section contains the specifications for the SignalScout RFM151 RF analyzer. All specifications are guaranteed unless labeled “typical.” Typical specifications are provided for your convenience and are not guaranteed.

NOTE. Performance requirements listed in this section are valid provided the instrument is operating within environmental parameters and has been warmed up for at least 20 minutes. Test equipment used to verify performance requirements must be calibrated and working with the limits specified in the Required Equipment list on page 5-3.

Table 4-1: Electrical specifications

Characteristic	Requirement	Supplemental information
Overvoltage category		
Power inputs:	Cat I (IEC 1010-1)	
Measuring inputs:	Cat II (IEC 1010-1)	
RF Input		
Connector		Precision F type
Impedance	75 Ω	
Maximum input power	+68 dBmV	Total input power sum of all channels
Return loss		Attenuation set to 0 dB. F type connector
5 to 10 MHz	> 6 dB	Instrument frequency set above 40 MHz
	> 7 dB	Instrument frequency set below 40 MHz
10 to 40 MHz	> 10 dB	At all times

Specifications

Table 4–1: Electrical specifications (Cont.)

Characteristic	Requirement	Supplemental information
40 to 750 MHz	> 13 dB	Instrument frequency set above 40 MHz
750 to 1080 MHz	> 11 dB	Instrument frequency set above 40 MHz
40 to 1080 MHz	> 3 dB	Instrument frequency set below 40 MHz
Frequency		
Accuracy	± 5 kHz or $\pm 10^{-5}$ of tuned frequency	Whichever is higher
Range	5 to 1080 MHz	
Amplitude accuracy ^{1,2,3,4}		
For 5 to 10 MHz range	± 1.6 dB	1.9 dB for –35 to –20 dBmV
For 10 to 40 MHz range	± 1.2 dB	1.7 dB –35 to –20 dBmV
For 40 to 750 MHz range	± 1.0 dB	1.5 dB –35 to –20 dBmV
For 750 to 1080 MHz range	± 1.1 dB	1.6 dB –35 to –20 dBmV
Amplitude range	–35 to +60 dBmV (+25 to +120 dB μ V)	
Amplitude repeatability	± 0.5 dB	For external changes less $< \pm 5^\circ$ C

1 Carrier to noise ≥ 25 dB

2 Visual carrier variation < 10 dB over 300 MHz, plus 1 dB for each additional 100 MHz up to 17 dB total.

3 Disconnect input during self calibration for signal with amplitudes > 50 dBmV and frequencies > 500 MHz

4 Preamp off

Table 4–1: Electrical specifications (Cont.)

Characteristic	Requirement	Supplemental information
Channel input		
Channel ID	1–511	5 to 1080 MHz
Probe loss	–60 to +60 dB	User definable in 0.1 dB increments
Amplitude offset	–12.5 to +12.5 dB	User definable in 0.1 dB increments
Reference level units	dBmV or dB μ V	
Analog channel		
Visual to aural difference		Channel sensitive, in-service measurement; Four averaged measurements per second; No noise calibration cycles
Accuracy	± 1 dB	
Repeatability	± 0.5 dB	
Visual carrier to noise		Channel sensitive, in-service or out-of-service; < 6 second measurement time
Accuracy		
5 to 40 MHz	± 2 dB up to 40 dB	For carrier amplitude ≥ 0 dBmV measured in-service with modulation
5 to 40 MHz	± 2 dB up to 40 dB	For carrier amplitude ≥ 5 dBmV measured out-of-service without modulation during the noise measurement
41 to 750 MHz	± 2 dB up to 46 dB (49 dB, typical)	For carrier amplitude ≥ 0 dBmV measured in-service with modulation
41 to 750 MHz	± 2 dB up to 51 dB	For carrier amplitude ≥ 5 dBmV measured out-of-service without modulation during the noise measurement
750 to 1080 MHz	± 2 dB up to 46 dB typical	For carrier amplitude ≥ 0 dBmV measured in-service with modulation

Specifications

Table 4-1: Electrical specifications (Cont.)

Characteristic	Requirement	Supplemental information
750 to 1080 MHz	± 2 dB up to 51 dB typical	For carrier amplitude ≥ 5 dBmV measured out-of-service without modulation during the noise measurement
Repeatability	± 1 dB	
Noise frequency offset	Up to ± 32 MHz	
C/N Bandwidth	1 to 8 MHz	
Hum		Channel sensitive, in-service measurement
Range	0 to 5%	
Frequency	50 or 60 Hz	
Accuracy	$\pm 1\%$	For visual carrier amplitude ≥ 0 dBmV and visual carrier to noise ≥ 25 dB
AM/FM aural channel		
Demodulation modes	AM, FM, and AM and FM	
FM deviation	$\pm 10\%$ of peak deviation of main aural carrier or ± 2 kHz	Whichever is greater; Applies to rates from 20 Hz to 7.5 kHz and deviation from 5 to 25 kHz
Digital channel		
Digital carrier average power		Channel sensitive measurement 1 or 2 measurements per second (fast or slow)
Modulation envelope lower edge	5 to 1080 MHz	At -20 to $+60$ dBmV
Carrier bandwidth	100 kHz to 8 MHz	User definable
Repeatability	± 0.5 dB	

Table 4–1: Electrical specifications (Cont.)

Characteristic	Requirement	Supplemental information
Accuracy ⁵		
For 5 to 10 MHz range	±1.6 dB	1.9 dB for –35 to –20 dBmV
For 10 to 40 MHz range	±1.2 dB	1.7 dB –35 to –20 dBmV
For 40 to 750 MHz range	±1.0 dB	1.5 dB –35 to –20 dBmV
For 750 to 1080 MHz range	±1.1 dB	1.6 dB –35 to –20 dBmV
Visual carrier to digital difference		Auto and manual modes
Input signal	5 to 1080 MHz	At –20 to +60 dBmV
Carrier bandwidth	100 kHz to 8 MHz	User definable
Accuracy		
For 5 to 10 MHz range	±3.2 dB	3.8 dB for –35 to –20 dBmV
For 10 to 40 MHz range	±2.4 dB	3.4 dB –35 to –20 dBmV
For 40 to 750 MHz range	±2.0 dB	3.0 dB –35 to –20 dBmV
For 750 to 1080 MHz range	±2.2 dB	3.2 dB –35 to –20 dBmV
Repeatability	±1 dB	
Desired to undesired		Channel sensitive, out-of-service, < 15 seconds measurement time
Input signal	5 to 1080 MHz	–20 to +60 dBmV
Carrier bandwidth	100 kHz to 8 MHz	User definable

⁵ When the apparent peak of the average spectral amplitude is ≥ 0 dB and signal to noise ≥ 25 dB.

Specifications

Table 4-1: Electrical specifications (Cont.)

Characteristic	Requirement	Supplemental information
Accuracy		
For 5 to 10 MHz range	±3.2 dB	3.8 dB for -35 to -20 dBmV
For 10 to 40 MHz range	±2.4 dB	3.4 dB -35 to -20 dBmV
For 40 to 750 MHz range	±2.0 dB	3.0 dB -35 to -20 dBmV
For 750 to 1080 MHz range	±2.2 dB	3.2 dB -35 to -20 dBmV
Repeatability	±1 dB	
Relative field strength		
Input signal	5 to 1080 MHz	At -60 to +60 dBmV
Attenuation	0 to 55 dB	User definable in 5 dB steps
Resolution bandwidth	30 kHz or 300 kHz	3 dB
Spectrum Analyzer		
Frequency range	5 to 1080 MHz	
Span per division	200 and 400 kHz and 1, 2, and 4 MHz	
Resolution bandwidth		
At 200 kHz span	30 kHz	
At 400 kHz span	30 kHz	
At 1 MHz span	300 kHz	
At 2 MHz span	300 kHz	
At 4 MHz span	300 kHz	
Sensitivity	-60 dBmV	Worst case
Max hold	On or Off	
Detection mode	Peak or Average	

Table 4-1: Electrical specifications (Cont.)

Characteristic	Requirement	Supplemental information
Spurious free dynamic range		System visual carrier variation must be <10 dB over 300 MHz plus 1 dB for each additional 100 MHz up to 17 dB total
5 to 20 MHz	-45 dBc	With equal visual carrier levels or with external preselection filter of 3 or fewer channels
20 to 1080 MHz	-50 dBc	
5 to 1080 MHz	-40 dBc	No preselection
55 to 1080 MHz	-70 dBc	Measurement of spurs 5 to 40 MHz
Residual spurious responses		
5 to 40 MHz	-40 dBmV	With preamp on
40 to 1080 MHz	-50 dBmV	With preamp on

Table 4-2: AC power source characteristics

Name	Characteristics		
Mains Voltage Range			
Std – US	108 – 132 volts	60 Hz,	18W (max)
A1 – Universal Euro	198 – 242 volts	50 Hz,	18W (max)
A2 – UK	216 – 264 volts	50 Hz,	18W (max)
A3 – Australia	216 – 264 volts	50 Hz,	18W (max)
A6 – Japan	90 – 110 volts	50/60 Hz,	18W (max)

Specifications

Table 4-3: DC power characteristics

Characteristic	Requirement
Supply range	10V to 15V DC
Power	10W at 12V DC

Table 4-4: Battery characteristics⁶

Characteristic	Requirement	Supplemental information
Type	NiCd	
Voltage	9.6 V	
Life		
Operating	2.75 hours	Backlight off, no connection to RS-232 port, typical use
Sleep state	36 hours	No connection to RS-232 port
Non-operating	6 months	
Internal charge time	8 hours	Temperature between 10° C and 45° C
External charge time	2 hours	Temperature between 10° C and 45° C

⁶ See the *General Safety Summary* on page xii for information about how to properly dispose of used batteries.

Table 4–5: Certifications and compliances

EC Declaration of Conformity – EMC	<p>Meets intent of Directive 89/336/EEC for Electromagnetic Compatibility. Compliance was demonstrated to the following specifications as listed in the Official Journal of the European Communities:</p> <p>EN 55011 Class A Radiated and Conducted Emissions</p> <p>EN 50082-1 Immunity:</p> <p>IEC 1000-4-2-2 Electrostatic Discharge Immunity</p> <p>IEC 801-3RF Electromagnetic Field Immunity</p> <p>IEC 801-4 Electrical Fast Transient/Burst Immunity</p> <p>IEC 801-5 Power Line Surge Immunity</p>
FCC Compliance	Emissions comply with FCC Code of Federal Regulations 47, Part 15, Subpart B, Class A Limits
EC Declaration of Conformity – Low Voltage ¹	<p>Compliance was demonstrated to the following specification as listed in the Official Journal of the European Communities:</p> <p>Low Voltage Directive 73/23/EEC</p> <p>EN 61010-1:1993</p> <p>Safety requirements for electrical equipment for measurement, control, and laboratory use</p>
Approvals ¹	<p>ANSI/ISA S82.01 – Safety standard for electrical and electronic test, measuring, controlling, and related equipment, 1994</p> <p>CAN/CSA C22.2 No. 1010.1 – Safety requirements for electrical equipment for measurement, control and laboratory use</p>

¹ Conditions of certification: Operating temperature, +5° C to +40° C; Maximum operating altitude, 2000m (6,560 feet); Humidity, For temperatures up to 31° C, up to 80%, decreasing linearly to 50% at 40° C; Equipment type, test and measuring; Pollution degree, 2; Safety class, II

Specifications

Table 4-5: Certifications and compliances (cont.)

Installation Category Descriptions	<p>Terminals on this product may have different installation category designations. The installation categories are:</p> <p>CAT III Distribution-level mains (usually permanently connected). Equipment at this level is typically in a fixed industrial location</p> <p>CAT II Local-level mains (wall sockets). Equipment at this level includes appliances, portable tools, and similar products. Equipment is usually cord-connected</p> <p>CAT I Secondary (signal level) or battery operated circuits of electronic equipment</p>
------------------------------------	---

Table 4-6: Environmental characteristics

Characteristic	Requirement	Supplemental information
Operating Temperature	-10 to +50° C (14 to 122° F)	-10 to 0° C (14 to 32° F), typical
Storage Temperature	-20 to +60° C (-4 to +140° F)	Limited by LCD display
Humidity		
Operating	95%, Up to +30° C, non-condensing	
	75%, From +31° C to +40° C, non-condensing	
	45%, From +41° C to +50° C, non-condensing	
Non Operating	95%, To 50° C, non-condensing	
Altitude (Operating)	15,000 feet (4572 meters)	Derate operating temperature by 1° C for every 1000 feet of gain above 5000 feet
Altitude (Non-operating)	40,000 feet (12192 meters)	

Table 4-7: Physical characteristics

Characteristic	Dimension
Height	8 in (20.32 cm)
Width	11.2 in (28.45 cm)
Depth	4 in (10.16 cm)
Weight	< 8.5 pounds; without carrying case, battery included

Specifications



WARNING

The following servicing instructions are for use only by qualified personnel. To avoid injury, do not perform any servicing other than that stated in the operating instructions unless you are qualified to do so. Refer to all Safety Summaries before performing any service.

Performance Check

Perform this procedure after installing a Calibrated Board Set, or any time you require a check of instrument performance. The following specifications and functions are checked:

Specifications

- Carrier amplitude measurement accuracy
- Hum measurement accuracy
- FM deviation measurement accuracy

Partially Verified Calibration Tables

- Noise Calibrator Bias
- Noise Calibrator Correction
- 5 dB, 10 dB, and first 20 dB attenuator steps
- IF1GAIN adjustment
- IF3GAIN adjustment
- Log Detector
- Resolution BW Filter Insertion Loss
- Lin Detector
- FM Detector
- AM Detector
- Reference Oscillator Correction

Other Instrument Functions Checked

- Battery Operation
- External Power Operation
- Communications Port
- Front Panel Operation

Performance Check

Table 5-1: Test record for the RF analyzer

Serial number:

Date:

Procedure step		Test result	
1.	Verify battery & power key oper.		
2.	Verify oper. from ext. power source		
	Nominal input frequency: Power	Power meter (dBmV)	RF analyzer (dBmV)
5c.	10 MHz: +38.7 dBmV		
5d.	40 MHz: +38.7 dBmV		
5d.	110 MHz: +38.7 dBmV		
5d.	210 MHz: +38.7 dBmV		
5d.	310 MHz: +38.7 dBmV		
5d.	410 MHz: +38.7 dBmV		
5d.	510 MHz: +38.7 dBmV		
5d.	610 MHz: +38.7 dBmV		
5d.	710 MHz: +38.7 dBmV		
5d.	810 MHz: +38.7 dBmV		
5d.	910 MHz: +38.7 dBmV		
5d.	1000 MHz: +38.7 dBmV		
Procedure step		Expected result	Test result
6d.	Check residual hum	less than 0.5%.	
6f.	Verify hum measurement	5% ± 1% (4% to 6%)	
7c.	Verify FM deviation measurement accuracy with 12 kHz of deviation input	12 kHz ± 3.2 kHz	
7e.	Verify FM deviation measurement accuracy with 25 kHz of deviation input	25 kHz ± 4.5 kHz	
8.	IF filter amplitude calibration	Change between 30 kHz and 300 kHz. BW is 1 dB or less.	

Required Equipment

RF Signal Source

Frequency Range: 10 MHz to 1000 MHz

Accuracy: ± 500 Hz

Amplitude Range: 0 dBm maximum output (50 Ω or 75 Ω)

FM Modulation (internal or external): Deviation range 5 kHz to 25 kHz. Rate between 20 Hz and 7.5 kHz.

AM Modulation (internal or external): Amplitude range 0 to 2.5% (corresponds to 0 to 5% SignalScout RF analyzer reading). Rate 50, 60, 100 or 120 Hz.

Example: Hewlett-Packard 8657A Signal Generator with a Tektronix CFG250 Function Generator

The function generator is used when testing hum accuracy, to drive the external modulation input to generate the 50, 60, 100, or 120 Hz AM modulation rate.

Function Generator

For testing hum accuracy, use a function generator to drive the external modulation input of the RF signal source to generate a 60 Hz sine wave.

Example: Tektronix CFG250 Function Generator

Power Meter With 75 Ω Sensor Head

Sensitivity: -20 dBm

Frequency Range: 10 MHz to 1 GHz

Accuracy: ± 0.1 dB

Example: Hewlett-Packard 438A Power Meter with Hewlett-Packard 8483A Sensor Head

50 Ω to 75 Ω Matching Pad

Required only if RF signal source output impedance is 50 Ω .

Frequency Range: 10 MHz to 1 GHz

Performance Check

Nominal Insertion Loss: 5.7 dB

Return Loss: 75 Ω or 50 Ω ≥ 20 dB

Example: Hewlett-Packard 11852B

Interconnecting Cables

50 Ω if RF signal source output impedance is 50 Ω .

75 Ω if RF signal source output impedance is 75 Ω .

RS-232 cable

Signal Characterization

1. Connect the test equipment as shown in Figure 5-1, 5-2, or 5-3.

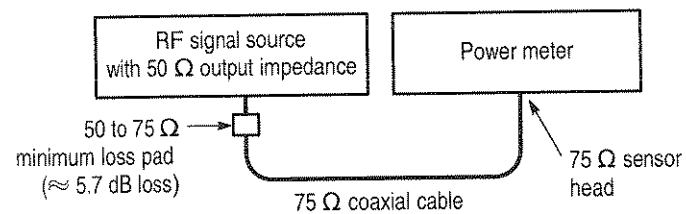

Figure 5-1: Hookup for 50 Ω source output

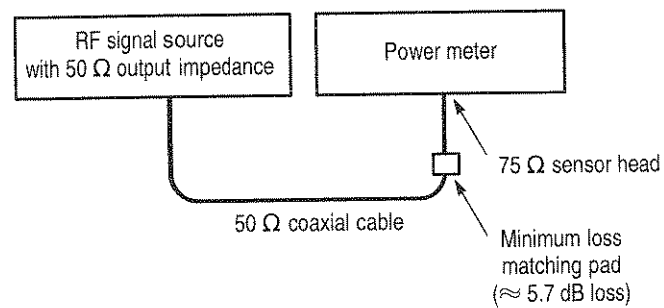

Figure 5-2: Alternate hookup for 50 Ω source output

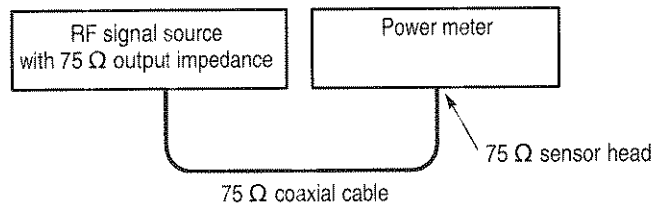

Figure 5–3: Hookup for 75 Ω source output

2. Set up the RF signal source as follows:
 - Frequency: 10 MHz
 - Amplitude: Adjust for -10 dBm ($+38.7$ dBmV) power meter reading. (If a matching pad is being used, the output power of the generator must be increased to compensate for this loss.)
3. Make a copy of Table 5–1 (see page 5–2). Record the power meter reading in row 5c., column “Power Meter (dBmV).”

If your power meter does not display amplitude in dBmV, add $+48.7$ to the reading in dBm to convert to dBmV.
4. Repeat steps 2 and 3 for frequencies of 40, 110, 210, 310, 410, 510, 610, 710, 810, 910 and 1000 MHz. Record the results in the “Power Meter (dBmV)” column for the individual frequencies.

Performance Check Procedure

Record the results of this procedure on your copy of Table 5–1.

1. Verify battery and POWER key operation as follows:
 - a. With the AC adapter disconnected from the instrument, press **[POWER]** to turn on the SignalScout RF analyzer.
 - b. A low-pitched beep followed by a high-pitched beep will signal that the instrument is initializing. The instrument title screen will be displayed briefly, followed by a measurement screen.
 - c. Press **[POWER]** to turn off the instrument. Check that the screen is blank.
2. Verify operation from an external power source as follows:
 - a. With the instrument turned off, plug the AC adapter into the DC input connector.
 - b. Plug the AC adapter into a compatible power source.
 - c. The instrument will emit two short beeps, and the screen will remain blank.
 - d. Press **[POWER]** to turn on the SignalScout RF analyzer.
 - e. A low-pitched beep followed by a high-pitched beep will signal that the instrument is initializing. The instrument title screen will be displayed briefly, followed by a measurement screen.
3. Use the following key sequence to make the CATV–STD channel table the active table:
[UTIL] [F3] {use knob to select CATV–STD} [F1].
4. Use the following key sequence to select the 1 channel measurement mode:
[LEVEL] [F1].
5. Verify amplitude accuracy using the following procedure:
 - a. Use the following key sequence to tune the SignalScout RF analyzer to 10 MHz: **[1] [0] [MHz]**.

- b. Apply a 10 MHz sinusoidal signal at a characterized amplitude of +38.7 dBmV (in 75 Ω) to the RF input.
 - c. Record the SignalScout RF analyzer reading in your copy of Table 5–1. Verify that this value is within 1 dB of the recorded power meter reading.
 - d. Repeat for frequencies of 40, 110, 210, 310, 410, 510, 610, 710, 810, 910 and 1000 MHz.
6. Verify hum measurement accuracy as follows:
- a. Use the following key sequence to tune the SignalScout RF analyzer to 511.25 MHz: [5] [1] [1] [.] [2] [5] [MHz].
 - b. Input a +38.7 dBmV, 511.25 MHz sinusoidal signal.
 - c. Use the following key sequence to select hum measurement mode: [MEAS] [F2].
 - d. Verify that the residual hum reading is less than 0.5%. Record the SignalScout RF analyzer reading in your copy of Table 5–1.
 - e. Apply 2.5% AM modulation at a rate of either 50, 60, 100, or 120 Hz.

NOTE. If the AM modulation rate cannot be set to these values on the signal generator, use an external modulation source and adjust the amplitude according to that manufacturer's setup procedure.

- f. Verify that the displayed hum reading is $5 \pm 1\%$. Record the SignalScout RF analyzer reading in your copy of Table 5–1.

NOTE. The SignalScout RF analyzer Hum reading is the ratio of peak-to-peak AM modulation to carrier level, per the NCTA standard. The displayed result will be twice the percent modulation setting on the generator.

Performance Check

7. Verify FM deviation measurement accuracy as follows:
 - a. With the instrument still tuned to 511.25 MHz, apply a +38.7 dBmV, 515.75 MHz sinusoidal signal with 12 kHz of deviation at a rate between 20 Hz and 7.5 kHz.
 - b. Use the following key sequence to select FM deviation measurement mode: **[MEAS] [F3]**.
 - c. Verify that the reading is $12 \text{ kHz} \pm 3.2 \text{ kHz}$. Record the SignalScout RF analyzer reading in your copy of Table 5-1.
 - d. Increase the FM deviation of the input signal to 25 kHz.
 - e. Verify that the reading is $25 \text{ kHz} \pm 4.5 \text{ kHz}$. Record the SignalScout RF analyzer reading in your copy of Table 5-1.
8. Verify IF filter amplitude calibration as follows:
 - a. Apply a +38.7 dBmV, 511.25 MHz signal.
 - b. With the instrument still tuned to 511.25 MHz, use the following key sequence to select Meter mode: **[LEV-EL] [F5]**.
 - c. Press **[F4]** to set the detection mode to AVG.
 - d. Make a note of the measured signal level at 300 kHz BW.
 - e. Press **[F3]** until the resolution BW from 300 kHz to 30 kHz.
 - f. Step the signal generator in 1 kHz steps from 511.245 to 511.255 MHz and note the highest reading produced by the RF analyzer.
 - g. Compare this reading with the one taken in step 8d.
 - h. Verify that the amplitude reading has not changed by more than 1 dB. Record the SignalScout RF analyzer reading in your copy of Table 5-1.

Front Panel / Backlight / Clock Operation Check

9. If the SignalScout RF analyzer is already in use, proceed to step 10. Otherwise, power up the instrument as follows:
 - a. With the SignalScout RF analyzer turned off, plug the AC adapter into the DC input connector.
 - b. Plug the AC adapter into a compatible power source.
 - c. Press **[POWER]** to turn the instrument on.
10. Press **[DISP]** to enter the Display menu.
 - a. Check that the words “DISPLAY MENU” appear in the upper left portion of the screen.
 - b. Use the knob to turn the backlight off and on. Leave it set as desired.
11. Press **[LEVEL]** to enter the Level menu. Check that the five function key assignments appear along the bottom of the screen, as shown in Figure 5-4.

1 CHAN	PILOTS	5 CHAN	ALL CHAN	METER
-----------	--------	-----------	-------------	-------

Figure 5-4: Level menu function key assignments

12. Press **[MEAS]** to enter the Measurement menu. Check that the function key assignments appear along the bottom of the screen, as shown in Figure 5-5.

C/N	HUM	FM DEV	D/U	FIELD STRGTH
-----	-----	-----------	-----	-----------------

Figure 5-5: Measurement menu function key assignments

13. Press [UTIL] to enter the Utility menu. Check that the function key assignments shown in Figure 5-6 appear along the bottom of the screen.

INST CONFIG	MSMT CONFIG	CHAN TABLE		
----------------	----------------	---------------	--	--

Figure 5-6: Utility menu function key assignments

- a. Press [F1] [F2] to display the clock menu. Verify that the clock is functional by checking that the day, month, and year are correct.

NOTE. Crossing the international dateline can cause the date to be off by one day. Similarly, crossing time zones can cause the time to be incorrect. If the clock is not correct, you can reset it after completing this procedure. See page 3-68 for instructions.

14. Press [SWEEP] to enter the Sweep mode. Check that the word "SWEEP" appears in the upper right corner of the screen.
15. Press [STORE] to enter the Store menu. Check that the function key assignments as shown in Figure 5-7 appear along the bottom of the screen.

STORE RSLT	RSLTS MENU	SITE NAME	SET TEMP	
---------------	---------------	--------------	-------------	--

Figure 5-7: Store menu function key assignments

- a. Press [F3] to enter the Site Name sub-menu. Check that "SITE NAME MENU" appears in the upper left corner of the screen.
- b. Press [F2] to select a new site. Check that "EDIT SITE NAME" appears in the upper left corner of the screen.

- c. Note that the character “A” of the on-screen alphabet has a box around it. Turn the knob clockwise to circle each of the letters, one letter for each detent click of the knob. Turn the knob counter-clockwise and return to the character “A.”
 - d. Press **[ENTER]** to enter the “A” as the first character in the site name. Check that an “A” appears in the site name box.
 - e. Press the following key sequence:
[1] [2] [3] [4] [5] [6] [7] [8] [9] [0] [.]
Check that all of these characters appear in the site name box. (It is not necessary to press ENTER when entering characters from the numeric keypad.)
 - f. Press **[←]** to remove the “.” from the display. Check that it is removed.
 - g. Press **[F4]** to accept the site name entry. Check that the instrument returns to the Site Name menu (“SITE NAME MENU” appears in the upper left corner of the screen) and that the new site name (A1234567890) is the last site name in the list.
 - h. With the last site name still selected, press **[F4]** to delete it. A query screen will appear. Press **[F1]** to confirm. Check that the site name (A1234567890) has been removed from the list.
 - i. Press **[+/-]** and check that the instrument emits a beep. (The key is not valid in this mode.)
16. Press **[SPECT][F1]** to enter the General Purpose Spectrum mode. Check that the word “SPECTRUM” appears in the upper right corner of the screen.
 17. Press **[MHz]** and check that the frequency readout at the top of the screen appears outlined. Press **[CHAN]** and check that the channel readout is outlined. Press **[MHz]** again and check that the frequency readout is outlined.
 18. Press **[SEQ]** to enter the Sequence menu. Check that the words “SEQUENCE MENU” appear in the upper left corner of the screen.

Performance Check

19. Press **[HELP]** to access the help screen. Check that the words “Sequence Mode Help” appear in the upper left corner of the screen.
20. Press **[ESC]** once to exit Help mode to the Sequence Menu, and press **[ESC]** again to return to the Spectrum mode.

Communications Port Function Check

21. Use the supplied RS-232 cable to connect the SignalScout RF analyzer to the serial port of a computer or terminal. (More information is given in Appendix B.)
22. Press **[UTIL]** to enter the Utility menu, then press **[F1] [F1] [F1]** to select the RS232 menu.
 - a. Press **[F1]** to select BAUD RATE, then turn the knob to select (outline) the baud rate setting of 9600. Use this method to configure the SignalScout RF analyzer communications port as indicated below:

F1	BAUD RATE	9600
F2	PARITY	NONE
F3	FLOW CONTROL	XON/XOFF
F4	TERMINATOR	CRLF
F5	ECHO	OFF

- b. Check that the parameters on your computer or terminal match those given above.
23. On your computer, type the following sequence:
***IDN? <ENTER>**
 - a. This sends a request for identification to the SignalScout RF analyzer. Verify that an identification response is received by your computer, beginning with “TEKTRONIX,RFM151.”

- b. Check that an **[R]** appears in the top line of the SignalScout RF analyzer screen, indicating that the instrument is in the remote operating mode.
24. Connect the RS-232 cable from the RFM151 to a serial printer.
25. Press **[UTIL]** to enter the Utility menu, then press **[F1] [F1] [F2]** to select the Printer menu.
- a. Press **[F1]** to select BAUD RATE, then turn the knob to select (outline) the baud rate setting of 9600. Use this method to configure the SignalScout RF analyzer communications port as indicated below:
- | | | |
|----|---------------|--|
| F1 | BAUD RATE | 9600 |
| F2 | PARITY | NONE |
| F3 | FLOW CONTROL | CTS/RTS |
| F4 | OUTPUT FORMAT | Select the appropriate printer type from the options listed. |
- b. Check that the parameters on your printer match those given above.
26. Store and print a Spectrum measurement result using the following procedure:
- a. Press **SPECT**, then press **[F1]** to make a general purpose spectrum measurement.
- b. Press **STORE [F1]** to store the spectrum measurement.
- c. Press **[F2]** to display the stored result.
- d. Press and hold the **ESC** key until the instrument beeps (about three seconds).
- e. Check that the printed report is identical to the stored spectrum measurement result.

This completes the *Performance Check*.

Performance Check

Replacement Procedures

This section provides removal and replacement procedures for major instrument assemblies.

Required Equipment

- Torx[®] screwdriver: #10 and #15 tips (#15 unless noted)
- 9/16 in torque wrench for the RF input connector
- 7/16 in torque wrench for the encoder switch and RF input adapter
- 5/64 in hex wrench (for gasket inspection/replacement)
- Soldering iron if replacing the Front Panel circuit board assembly, speaker, encoder, or fuse



WARNING. *Opening the SignalScout RF analyzer case while an RF signal is applied can expose the operator to hazardous voltages. Always disconnect the RF INPUT connector from the SignalScout RF analyzer before opening the case.*



CAUTION. *The only service that you should perform during the warranty period is battery replacement. For board replacement during the warranty period, return the instrument to a Tektronix Service Center.*

When installing new circuit boards, or returning boards to Tektronix for exchange, be sure to use a clean, static-free work area, and follow anti-static handling methods. Be sure to place the exchange boards in an anti-static bag.

NOTE. *Work in a clean, static-free area and use proper anti-static procedures.*

Instrument Disassembly

1. Turn off the instrument. Disconnect the AC power and the RF input signal. If this is not done, hazardous voltages may be present in the instrument. Make sure there is no connection to the interface port.
2. Remove the instrument from its soft case and place it upside down on a padded surface to protect the large knob on the front of the instrument.
3. Remove the RF input adapter (if installed), using a 7/16 in wrench. Remove the nut and the two washers from the RF connector, using a 9/16 in wrench, and push the RF connector through to the inside of the instrument. To protect the instrument from water damage, be careful not to misplace the rubber gasket on the end of the RF connector.
4. Working from the back of the instrument, remove the ten screws that hold the instrument together.
5. Tip the rear part of the instrument back to partially open the instrument case, without stressing the ribbon cables or the RF input cable. Remove the instrument carrying strap and set it aside. Separate the instrument into two parts and lay them next to each other on the work surface, as shown in Figure 6-1.

Note the water-resistant gasket in the instrument front casing. Inspect the gasket for damage, and replace if necessary. Make sure that the gasket is firmly seated in the groove all the way around the front casing, and locked in place by small plastic tabs along the groove.

6. Disconnect the ribbon cable from the Back Board circuit board assembly.
7. Proceed to the instructions for replacing the desired module.

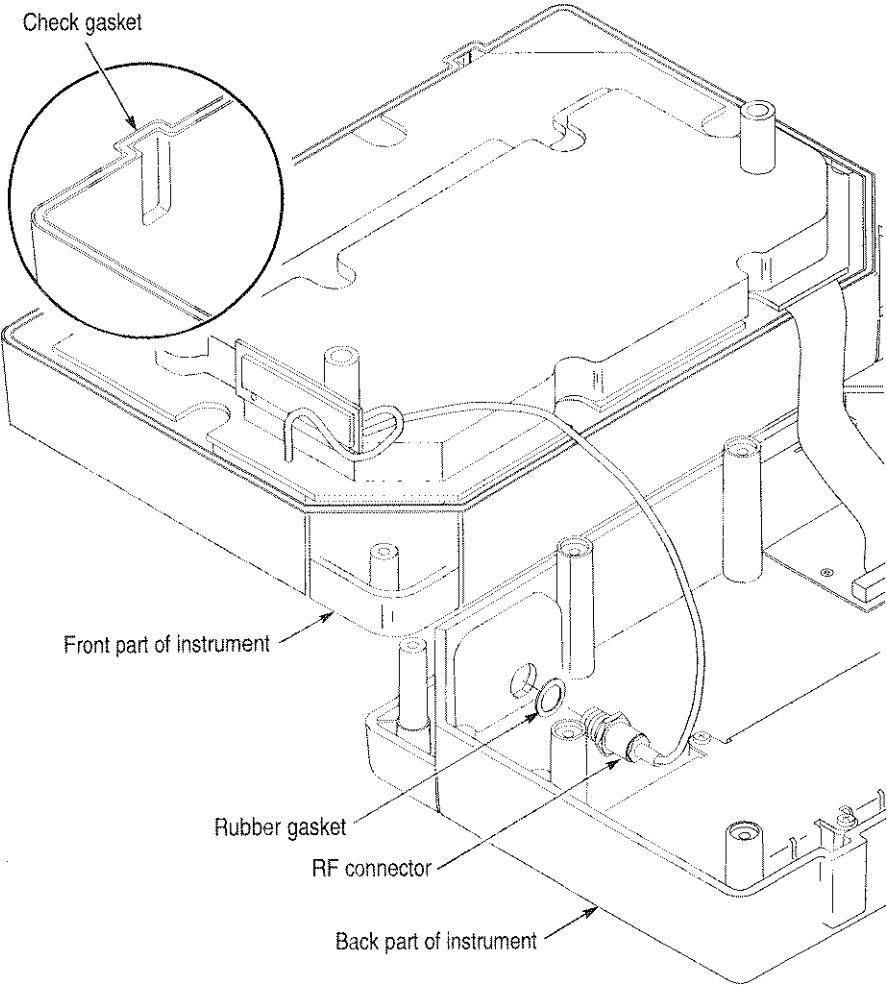

Figure 6-1: Separating the instrument into two parts

Replacing the Calibrated Board Set

Use this procedure to install a replacement Calibrated Board Set, consisting of the Processor/Power Supply circuit board assembly and the Analog Converter circuit board assembly. Return the exchange board set in the packaging in which you received the replacement board set. For questions regarding board exchange, contact your local Tektronix office, or call the Tektronix Beaverton Service Depot at 1-800-835-9433.

1. Perform *Instrument Disassembly* on page 6–2. This includes turning off the instrument and making sure there is no connection to AC power, RF input, or interface port.
2. Without removing any screws, lift the Calibrated Board set (consisting of the the Processor/Power Supply circuit board assembly and the Analog Converter circuit board assembly) from the instrument housing just enough to reach the cable that connects the board set to the Front Panel circuit board assembly. Disconnect the cable.
3. Remove the board set from the instrument.
4. Place the board set on a static-free surface with the LCD Display module facing up. Disconnect the dual-wire connector from J5 on the Processor board. Figure 6–2 shows the LCD Display module being removed from the Processor/Power Supply circuit board assembly. The Analog Converter circuit board assembly (not shown) is still connected to the Processor/Power Supply circuit board assembly.
5. Remove the four screws (#10 Torx[®] with attached locking washers) that hold the LCD Display module in place. Hold the LCD Display module near the bottom left corner, and remove it from the board set by working the pins loose. (The pins fit into a connector that is mounted on the other side of the Processor/Power Supply circuit board assembly.)
6. Place the board set in the static-safe bag.
7. Position the LCD Display module on the replacement Calibrated Board Set, inserting the pins into the Processor/Power Supply

circuit board assembly. Install the four screws that secure the LCD Display module and tighten to 4 in-lbs.

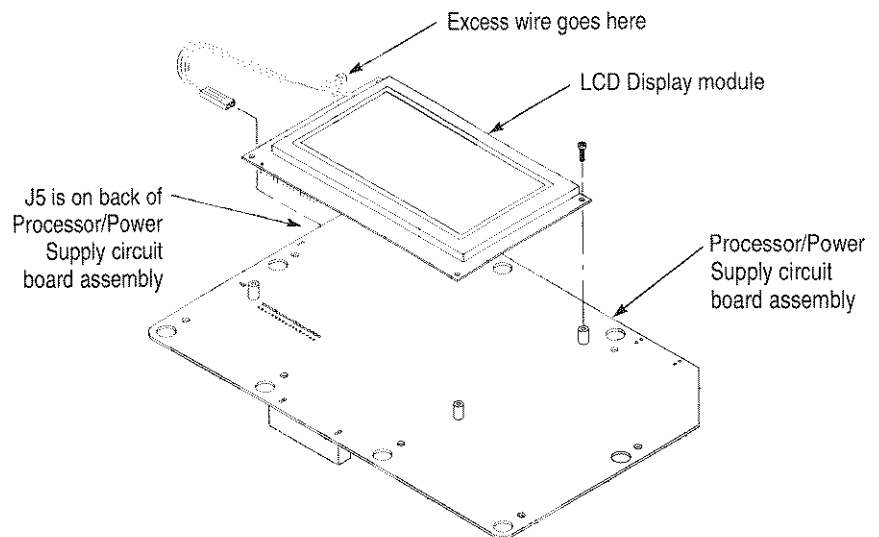

Figure 6-2: Removing the LCD Display module

8. Attach the dual-wire connector from the LCD Display module to J5 on the Processor/Power Supply circuit board assembly. Check that the wires are close to the Processor/Power Supply circuit board assembly, so that they will not be pinched during instrument assembly.
9. Clean the LCD Display and the clear filter on the front instrument casing with a soft, lint-free cloth dampened with a non-abrasive liquid glass cleaner.
10. Perform *Instrument Assembly* on page 6-19.
11. Complete the *Performance Check*, beginning on page 5-1.
12. Return the exchange board set, using the packaging in which you received the replacement board set.

Replacing the Charger/Battery Fuse

Use this procedure to replace the F1 circuit Charger/Battery fuse located on the back of the Processor/Power Supply circuit board assembly.

1. Perform *Instrument Disassembly* on page 6–2. This includes turning off the instrument and making sure there is no connection to AC power, RF input, or interface port.
2. Without removing any screws, lift the Calibrated Board set (consisting of the the Processor/Power Supply circuit board assembly and the Analog Converter circuit board assembly) from the instrument housing just enough to reach the cable that connects the board set to the Front Panel circuit board assembly. Disconnect the cable.
3. Remove the board set from the instrument.
4. Place the board set on a static-free surface with the LCD Display module facing up.

Removing the LCD Display module is not required to replace the battery fuse; however, it can become scratched or damaged during this procedure if you choose not to remove it. To avoid damaging the LCD Display module, remove it from the Processor/Power Supply circuit board assembly using the following substeps. Otherwise, continue the procedure at step 5.

- a. Disconnect the dual-wire connector from J5 on the Processor board. Figure 6–2 on page 6–5 shows the LCD Display module being removed from the Processor/Power Supply circuit board assembly. The Analog Converter circuit board assembly (not shown) is still connected to the Processor/Power Supply circuit board assembly.
- b. Remove the four screws (#10 Torx[®] with attached locking washers) that hold the LCD Display module in place. Hold the LCD Display module near the bottom left corner, and remove it from the board set by working the pins loose. (The pins fit into a connector that is mounted on the other side of the Processor/Power Supply circuit board assembly.) Set the LCD Display module aside.

5. Remove the eight Torx[®] screws from the Processor/Power Supply circuit board.
6. Carefully lift the Processor/Power Supply circuit board assembly from the Analog Converter circuit board assembly as shown in Figure 6–3 and place it on a static free surface.
7. Desolder and remove the 2.5A Charger/Battery fuse shown in Figure 6–3. Note how the fuse is positioned on the circuit board so that you can position the new fuse in the same way.



CAUTION. Use only the replacement fuse recommended for this instrument.

8. Resolder a 2.5A replacement fuse in place of the old one.
9. Replace the Processor/Power Supply circuit board assembly onto the Analog Converter circuit board assembly. Tighten the Torx[®] screws to 4 in-lbs.

If you removed the LCD Display module during this procedure, perform the following substeps to replace it referring to Figure 6–2. Otherwise, continue the procedure at step 10.

- a. Position the LCD Display module on the replacement Calibrated Board Set, inserting the pins into the Processor/Power Supply circuit board assembly. Install the four screws that secure the LCD Display module and tighten to 4 in-lbs.
 - b. Attach the dual-wire connector from the LCD Display module to J5 on the Processor/Power Supply circuit board assembly. Check that the wires are close to the Processor/Power Supply circuit board assembly, so that they will not be pinched during instrument assembly.
10. Clean the LCD Display and the clear filter on the front instrument casing with a soft, lint-free cloth dampened with a non-abrasive liquid glass cleaner.
 11. Perform *Instrument Assembly* on page 6–19.
 12. Perform the *Performance Check*, beginning on page 5–1.

Replacement Procedures

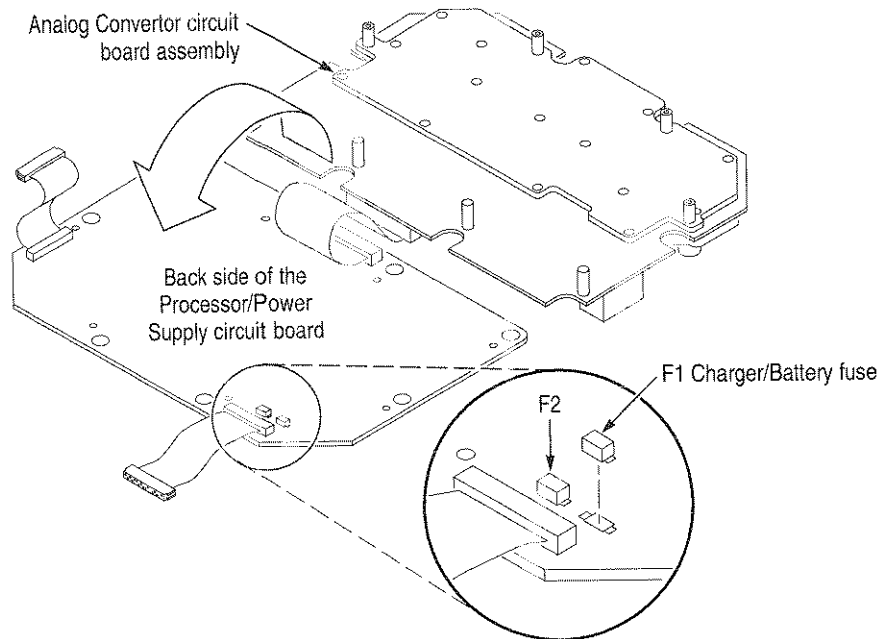
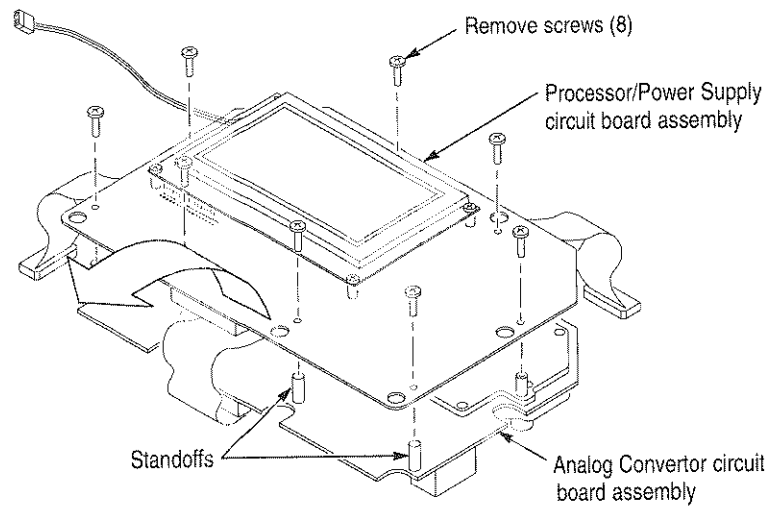

Figure 6-3: Replacing the battery fuse

Replacing the Front Panel Circuit Board Assembly, Speaker, Encoder, or Keypads

Use this procedure to replace the Front Panel circuit board assembly, the speaker and speaker gasket, the encoder and encoder gasket, and the keypads.

1. Perform *Instrument Disassembly* on page 6–2. This includes turning off the instrument and making sure there is no connection to AC power, RF input, or Interface Port.
2. Without removing any screws, lift the Calibrated Board set (consisting of the Processor/Power Supply circuit board assembly and the Analog Converter circuit board assembly) from the instrument housing just enough to reach the cable that connects the board set to the Front Panel circuit board assembly. Disconnect the cable.
3. Remove the board set from the instrument.
4. Desolder the speaker and encoder switch leads from the Front Panel circuit board assembly at J2, J3, and J4, as shown in Figure 6–4. (They will later be soldered to the replacement Front Panel circuit board assembly.)
5. Remove the 15 screws that hold the Front Panel circuit board assembly to the instrument. See Figure 6–4. Remove the stiffener, then lift the Front Panel circuit board assembly out of the instrument housing.
6. Replace the encoder (optional):
 - a. Using a 5/64 in hex wrench, remove the large knob from the front panel. Remove the spacer, if installed.
 - b. Using a 9/16 in wrench, remove the nut and two washers from the encoder.
 - c. Working from the inside of the front panel, lift out the encoder. Inspect the gasket and replace if necessary.

Replacement Procedures

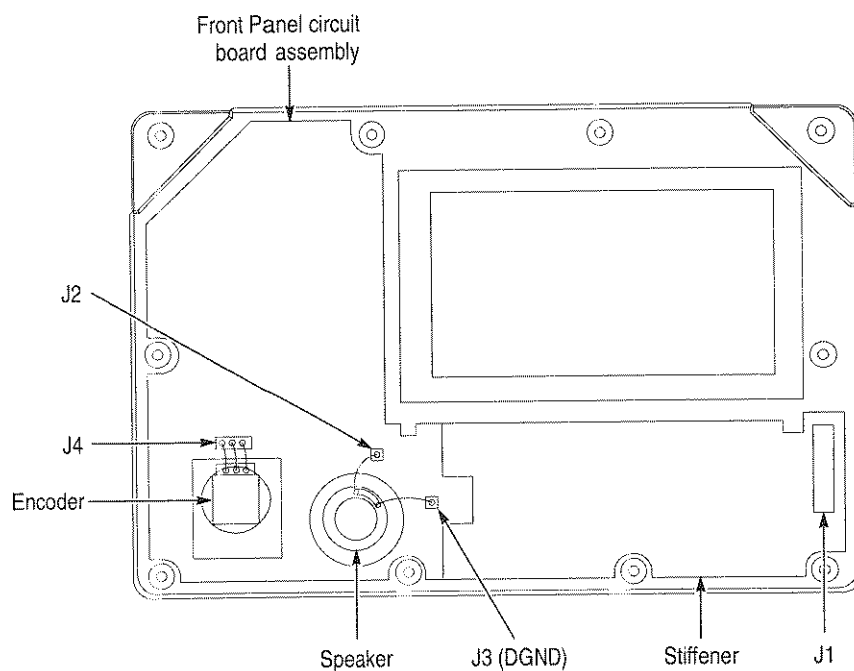

Figure 6-4: The front of the RF analyzer as seen from the inside

- d. Install the encoder gasket on the encoder. Insert the encoder through the inside of the front case, aligning the key tab on the encoder switch with the key slot on the front case. Make sure the leads are oriented toward the top of the instrument.
- e. Working from the outside of the instrument, place the flat washer, lock washer, then the nut on the outside of the shaft. Tighten the nut to 2 in-lbs. (Do not overtighten.) Turn the shaft to be sure the detent is functional.
- f. Place the large knob spacer (if available) on the post, then replace the large knob. (If the spacer is not available, while installing the knob, hold it slightly above the instrument to prevent it from binding.) Tighten the set screw.

7. Replace speaker or speaker gasket (optional):
 - a. Remove the speaker and gasket.
 - b. Install the replacement gasket. Position the speaker on the gasket.
8. Replace the keypads (optional):
 - a. Lift out the two keypads.
 - b. Install the replacement keypads in the front instrument casing, using a dental pick or similar instrument to press the keypad under the speaker housing.
9. Place the replacement Front Panel circuit board assembly in position. Place the stiffener on top of the Front Panel circuit board assembly. Install and partially tighten the 15 Front Panel circuit board assembly screws. From the front of the instrument, check the alignment of the keypads by pressing firmly on each key. Make sure the keys are making contact and adjust if necessary. Tighten all Front Panel circuit board assembly screws, beginning with those around the speaker, to 4 in-lbs.
10. Solder the speaker and encoder switch leads to the replacement Front Panel circuit board set, as shown in Figure 6-4.
11. Clean the clear filter on the instrument front case with a soft, lint-free cloth dampened with a non-abrasive liquid glass cleaner.
12. Perform *Instrument Assembly* on page 6-19.
13. Perform the following steps from the *Performance Check*, beginning on page 5-6:
Step 1, Step 2, and Steps 9 through 20.

Replacing the LCD Display Module

1. Perform *Instrument Disassembly* on page 6–2. This includes turning off the instrument and making sure there is no connection to AC power, RF input, or Interface Port.
2. Without removing any screws, lift the board set (consisting of the Processor/Power Supply circuit board assembly and the Analog Converter circuit board assembly) from the instrument housing just enough to reach the cable that connects the board set to the Front Panel circuit board assembly. Disconnect the cable.
3. Remove the board set from the instrument.
4. Place the board set on a static-free surface with the LCD Display module facing up. Disconnect the dual-wire connector from J5 on the Processor board. Figure 6–5 shows the LCD Display module being removed from the Processor/Power Supply circuit board assembly. The Analog Converter circuit board assembly (not shown) is still connected to the Processor/Power Supply circuit board assembly.
5. Remove the four screws (#10 Torx[®] with attached locking washers) that hold the LCD Display module in place. Hold the LCD Display module near the bottom left corner, and remove it from the board set by working the pins loose. (The pins fit into a connector that is mounted on the other side of the Processor/Power Supply circuit board assembly.)
6. Position the replacement LCD Display module on the board set, inserting the pins into the Processor/Power Supply circuit board assembly. Install the four screws that secure the LCD Display module and tighten to 4 in-lbs.

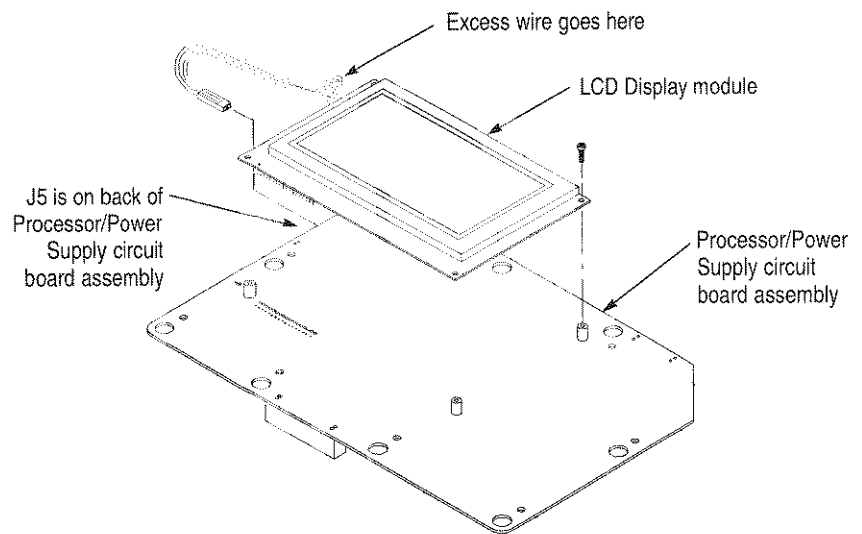

Figure 6-5: Removing the LCD Display module

7. Attach the dual-wire connector from the replacement LCD Display module to J5 on the Processor/Power Supply circuit board assembly. Check that the wires are close to the Processor/Power Supply circuit board assembly, so that they will not be pinched during instrument assembly.
8. Clean the LCD Display and the clear filter on the front instrument casing with a soft, lint-free cloth dampened with a non-abrasive liquid glass cleaner.
9. Perform *Instrument Assembly* on page 6-19.
10. Perform the following steps from the *Performance Check*, beginning on page 5-6:
Step 1, Step 2, and Steps 9 through 20.

Replacing the Back Board Circuit Board Assembly

1. Perform *Instrument Disassembly* on page 6–2. This includes turning off the instrument and making sure there is no connection to AC power, RF input, or Interface Port.
2. Referring to Figure 6–6, note the position of the battery pack. There is a two-wire lead that connects the Battery Interconnect circuit board assembly to the Back Board circuit board assembly at J502. Press the clip down to release the jumper at the Back board and slide the jumper off the pins.

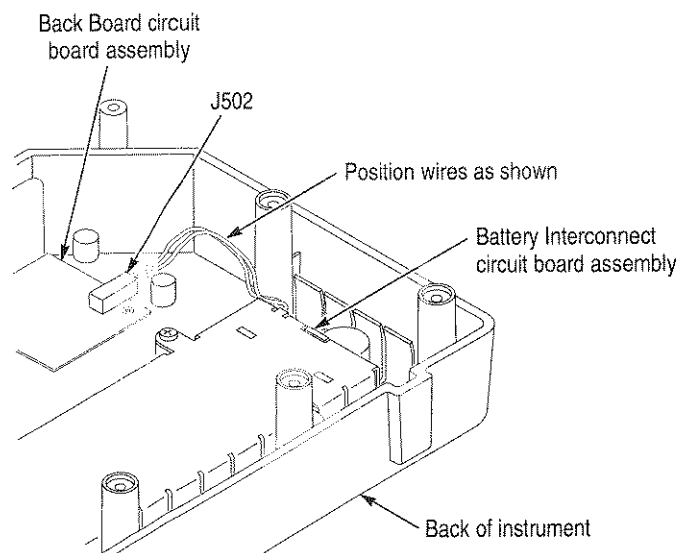

Figure 6–6: Removing the Back Board circuit board assembly

3. Working from the outside of the instrument, lift the soft cover from the communication port connector and remove the two screws from the connector.
4. Remove the two screws (#10 Torx[®]) from the Back Board circuit board assembly.

5. Pull the Back Board circuit board assembly away from the top of the instrument casing, and out of the instrument.
6. Install the new Back Board circuit board assembly by aligning the communication connector with the hole in the instrument casing. Make sure that the gasket around the connector lays flat when installed.
7. Partially install the two screws that attach the Back Board circuit board assembly to the instrument, but do not tighten.
8. Install and tighten the two screws on the communication port.
9. Tighten the two screws on the Back Board circuit board assembly to 4 in-lbs.
10. Install the battery cable to J502, being careful to position the lead as shown in Figure 6-6, so that it will not be pinched during instrument assembly. Check that the clip is locked on the pins.
11. Perform *Instrument Assembly* on page 6-19.
12. Perform the following steps from the *Performance Check*, beginning on page 5-6:
Step 1, Step 2, and Steps 21 through 23.

Replacing the Battery Interconnect Circuit Board Assembly

Removing the Battery Interconnect circuit board

1. Remove the battery using the *Removing the Battery* procedure described on page 0-1.
2. Perform *Instrument Disassembly* on page 6-2.
3. Referring to Figure 6-6 on page 6-14, note the position of the dual-wire lead that connects the Battery Interconnect circuit board assembly to the Back Board circuit board assembly at J502. Press the clip down to release the jumper at the Back board and slide the jumper off the pins.
4. Remove the battery shield screws and, lifting firmly from first one side and then the other, lift the battery shield away from the rear case half and put the rear case half away.

NOTE. *The battery shield is press fit and can be somewhat difficult to remove. You can turn the case half over and gently, but firmly, tap on the battery shield from the outside of the case half (again, first one side and then the other) to remove it. Make sure that the dual wire cable is disconnected and that the shield screws are removed first.*

5. Place the battery shield on a flat surface with the sides facing up as shown in Figure 6-7.
6. Remove the cable bushing by pressing on the retaining clips on either side of the bushing while you press the bushing back into the battery shield.
7. Remove the circuit board using the following procedure:
 - a. Gently pull the top part of the board away from the shield until it becomes loose.
 - b. Lift the Battery Interconnect circuit board with the attached dual-wire cable out of the battery shield.

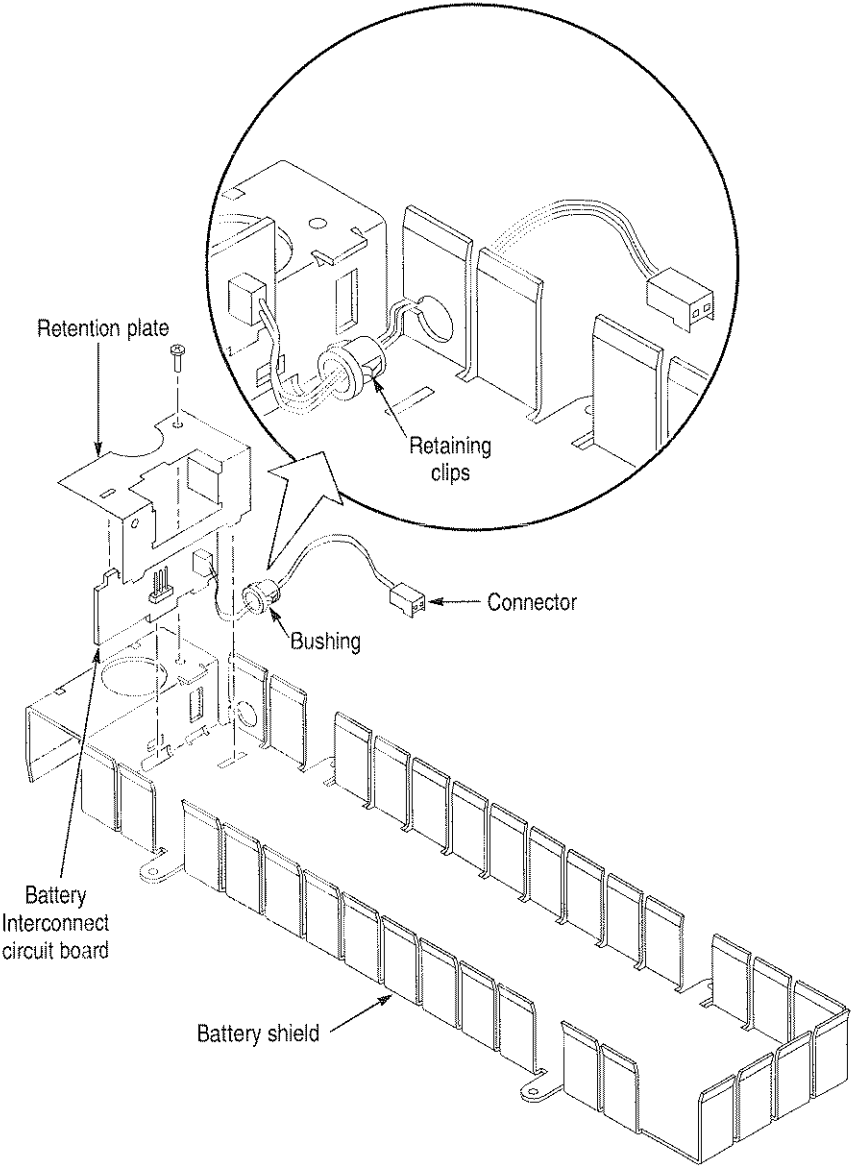

Figure 6-7: Battery Interconnect circuit board

Replacing the Battery Interconnect circuit board

1. Place the battery shield on a level surface with the sides of the shield facing up as shown in Figure 6-7.
2. Thread the dual wire cable through the slot in the battery shield with the connector on the outside of the shield and the bushing on the inside as shown in Figure 6-7.
3. Insert the bushing into the shield until the retaining clips snap into place.
4. Insert the Battery Interconnect circuit board by inserting the two bottom tabs into the tab slots provided and pressing the top of the board toward the board retaining clip until the board snaps into place.
5. Attach the retaining plate using the following procedure (refer to Figure 6-7):
 - a. Insert the retention plate tabs into the tabs slots provided in the battery shield.
 - b. Align the semicircular cutout with the large hole in the battery shield and attach the plate to the shield using the screw provided. Tighten to 8 in-lbs.
6. Turn the shield over and attach it to the rear case half using the screws provided. Align the four screw holes in the shield with the threaded inserts in the case half. Tighten the screws to 8 in-lbs.
7. Install the dual-wire battery cable to J502, being careful to position the lead as shown in Figure 6-6 on page 6-14, so that it will not be pinched during instrument assembly. Check that the clip is locked to the pins.
8. Perform *Instrument Assembly* on page 6-19.
9. Replace the battery using the *Installing the Battery* procedure on page 0-3.
10. Perform the following steps from the *Performance Check*, beginning on page 5-6:
Step 1, Step 2, and Steps 21 through 23.

Instrument Assembly

1. Position the two parts of the instrument next to each other on the work surface.
2. If the Calibrated Board Set has been removed from the instrument, perform sub-steps a through d:
 - a. Attach the cable leading from J11 on the replacement Calibrated Board Set to J1 on the Front Panel circuit board assembly.
 - b. Install the Calibrated Board Set, folding the excess cable length (from J1) between the Front Panel circuit board assembly and the Calibrated Board Set, so that the cable does not come between the edge of the circuit board assemblies and the instrument case. See Figure 6–8.
 - c. Check that the two wires coming from the LCD Display module are not pinched when installing the Calibrated Board Set. Make sure that the ribbon cable leading from J10 on the Processor/Power Supply circuit board assembly is extended so that it can be attached to the Back Board circuit board assembly in a later step.
 - d. Align the Calibrated Board Set with the eight posts in the instrument front casing.

Replacement Procedures

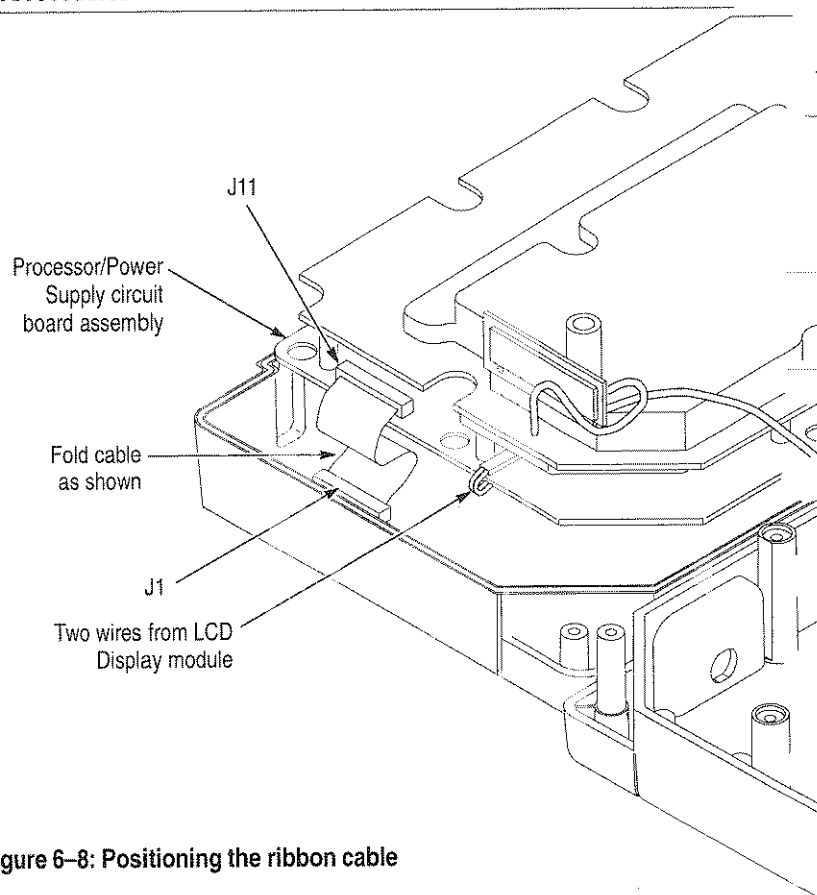

Figure 6–8: Positioning the ribbon cable

3. Insert the RF input connector through the keyhole in the back part of the instrument case. To maintain the weather-resistant quality of the product, be sure to keep the rubber gasket on the end of the RF connector in place. See Figure 6–9. Secure the RF connector from the outside of the case by installing first the flat washer, then the lock washer, and finally the nut. With the 9/16 in wrench, tighten the nut to 20 in-lbs.
4. Connect the ribbon cable from J10 on the Processor/Power Supply circuit board assembly to J500 on the Back Board circuit board assembly.
5. Slip the instrument carrying strap over the two posts on the back cover of the instrument.

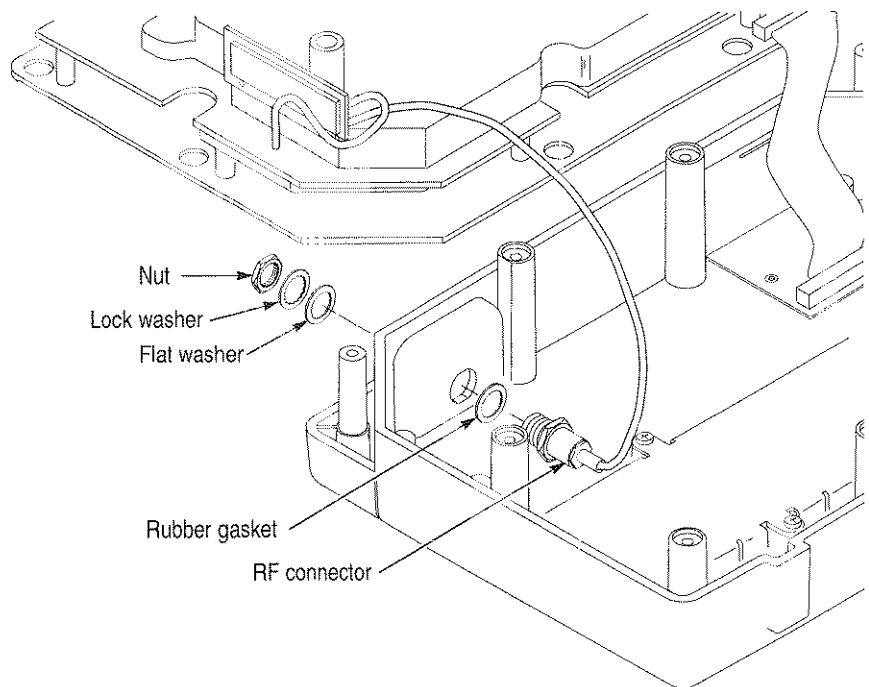

Figure 6-9: Installing the RF connector

6. Position the RF connector cable so that the cable will not be caught between the posts and the instrument case when the case is assembled. See Figure 6-9.
7. Connect the two parts of the instrument, aligning the posts. Be careful not to damage the water-resistant gasket that is installed in the front instrument casing.
8. Install the ten screws on the rear cover and tighten to 6 in-lbs.
9. If you are using an RF adapter, install it on the RF connector with the 7/16 in wrench. Tighten to 15 in-lbs.
10. This completes *Instrument Assembly*.

Replacement Procedures

Interior Cleaning



CAUTION. Do not allow water to get inside any enclosed assembly or component. Do not clean any plastic materials with benzene, toluene, xylene, acetone, or similar compounds, because they may damage the plastic.

This instrument is equipped with special seals and gaskets which eliminate the need for routine interior cleaning. However, if dirt has entered the instrument, it should be removed. Dirt acts as a thermal insulator, preventing effective heat dissipation, and can also provide high-resistance electrical leakage paths between conductors or components in a humid environment.



WARNING. Opening the SignalScout RF analyzer case while an RF signal is applied can expose the operator to hazardous voltages. Always disconnect the RF INPUT connector from the SignalScout RF analyzer before opening the case.



CAUTION. Do not allow water to get inside any enclosed assembly or component. Do not clean any plastic materials with benzene, toluene, xylene, acetone, or similar compounds, because they may damage the plastic.

After interior cleaning, allow the instrument to dry thoroughly before applying power.

Cleaning of rosin residue is not recommended for this product. Most cleaning solvents tend to reactivate the rosin and spread it under components where it may cause corrosion under humid conditions. The rosin residue, if left alone, does not exhibit these corrosive properties.

Required Equipment

- Torx[®] screwdriver: #10 and #15 tips (#15 unless noted)
- 9/16 in torque wrench for the RF Input connector
- 7/16 in torque wrench for the encoder switch and RF input adapter

Recommended Supplies

- Soft, lint-free, non-abrasive cloth for LCD screen
- Non-abrasive liquid glass cleaner for LCD screen
- Isopropyl alcohol (optional)
- Cotton swab (optional)
- Static-free vacuum cleaner with small brush attachment

Cleaning Procedure

Work at a clean, static-free work area, and use proper anti-static procedures.

1. Perform *Instrument Disassembly* on page 6–2. This includes turning off the instrument and making sure there is no connection to AC power, RF input, or Interface Port.
2. Without removing any screws, lift the board set (consisting of the the Analog Converter circuit board assembly and the Processor/Power Supply circuit board assembly) from the instrument housing just enough to reach the cable that connects the board set to the Front Panel circuit board assembly. Disconnect the cable.
3. Remove the board set from the instrument.
4. Use low-pressure dry air to remove accumulated dust and dirt from the inside of the instrument (high-velocity air can damage some parts). Hardened dirt or grease can be removed with a cotton swab dampened with isopropyl alcohol. Do not use abrasive cleaners. Do not clean rosin residue.
5. Clean the LCD display with a soft, lint-free cloth dampened with non-abrasive glass cleaner.



WARNING. Do not assemble, apply power, or apply RF signal input to the instrument until the interior is thoroughly dry.

6. Allow the interior to dry thoroughly.
7. Perform *Instrument Assembly* on page 6–19.
8. Perform the *Performance Check* on page 5–6.

Interior Cleaning

Replaceable Electrical Parts

This section contains a list of the components that are replaceable for the SignalScout RFM151 RF analyzer. Use this list to identify and order replacement parts.

Parts Ordering Information

Replacement parts are available through your local Tektronix field office or representative.

Changes to Tektronix products are sometimes made to accommodate improved components as they become available and to give you the benefit of the latest improvements. Therefore, when ordering parts, it is important to include the following information in your order.

- Part number
- Instrument type or model number
- Instrument serial number
- Instrument modification number, if applicable

If you order a part that has been replaced with a different or improved part, your local Tektronix field office or representative will contact you concerning any change in part number.

Change information, if any, is located at the rear of this manual.

Module Servicing

Modules can be serviced by selecting one of the following three options. Contact your local Tektronix service center or representative for repair assistance.

Module Exchange. In some cases you may exchange your module for a remanufactured module. These modules cost significantly less than new modules and meet the same factory specifications. For more information about the module exchange program, call 1-800-TEK-WIDE, extension 6630.

Module Repair and Return. You may ship your module to us for repair, after which we will return it to you.

New Modules. You may purchase replacement modules in the same way as other replacement parts.

Using the Replaceable Parts List

This section contains a list of the mechanical and/or electrical components that are replaceable for the RF analyzer. Use this list to identify and order replacement parts. The following table describes each column in the parts list.

Parts List Column Descriptions

Column	Column Name	Description
1	Figure & Index Number	Items in this section are referenced by figure and index numbers to the exploded view illustrations that follow.
2	Tektronix Part Number	Use this part number when ordering replacement parts from Tektronix.
3 and 4	Serial Number	Column three indicates the serial number at which the part was first effective. Column four indicates the serial number at which the part was discontinued. No entries indicates the part is good for all serial numbers.

Parts List Column Descriptions

Column	Column Name	Description
5	Name & Description	An item name is separated from the description by a colon (:). Because of space limitations, an item name may sometimes appear as incomplete. Use the U.S. Federal Catalog handbook H6-1 for further item name identification.
6	Mfr. Code	This indicates the code of the actual manufacturer of the part.
7	Mfr. Part Number	This indicates the actual manufacturer's or vendor's part number.

Abbreviations

Abbreviations conform to American National Standard ANSI Y1.1-1972.

Mfr. Code to Manufacturer Cross Index

The table titled Manufacturers Cross Index shows codes, names, and addresses of manufacturers or vendors of components listed in the parts list.

Replaceable Electrical Parts

Manufacturers Cross Index

Mfr. code.	Manufacturer	Address	City, state, zip code
80009	TEKTRONIX INC	14150 SW KARL BRAUN DR, PO BOX 500	BEAVERTON, OR 97077-0001

Replaceable Electrical Parts List

Cmpnt. number	Tektronix part number	Serial no. effective	Serial no. discont'd	Name & description	Mfr. code	Mfr. part number
A1	671-3101-00			CKT BD ASSY: FRONT PANEL	80009	671-3101-00
A2/A3	020-2215-00		B010383	CALIBRATED BOARD SET	80009	020-2215-00
A2/A3	020-2215-01	B010384	B010409	CALIBRATED BOARD SET	80009	020-2215-01
A2/A3	020-2215-02	B010410	B010600	CALIBRATED BOARD SET	80009	020-2215-02
A2/A3	020-2215-03	B010601		CALIBRATED BOARD SET	80009	020-2215-03
A4	671-3466-00			CKT BD ASSY: BACK BOARD	80009	671-3466-00
A5	671-4210-00			CIRCUIT BD ASSY: BATTERY INTERCONNECT	80009	671-4210-00

Parts List Column Descriptions

Column	Column Name	Description
6	Name & Description	An item name is separated from the description by a colon (:). Because of space limitations, an item name may sometimes appear as incomplete. Use the U.S. Federal Catalog handbook H6-1 for further item name identification.
7	Mfr. Code	This indicates the code of the actual manufacturer of the part.
8	Mfr. Part Number	This indicates the actual manufacturer's or vendor's part number.

Abbreviations

Abbreviations conform to American National Standard ANSI Y1.1-1972.

Mfr. Code to Manufacturer Cross Index

The table titled Manufacturers Cross Index shows codes, names, and addresses of manufacturers or vendors of components listed in the parts list.

Replaceable Mechanical Parts

Manufacturers Cross Index

Mfr. Code	Manufacturer	Address	City, state, zip code
0DWW6	SPM/MICRO POWER ELECTRONICS	22990 NW BENNETT ST	HILLSBORO, OR 97124
0GV90	GLOBTEK INC	186 VETERANS DRIVE	NORTHVALE, NJ 07647-2303
0KB01	STAUFFER SUPPLY CO	810 SE SHERMAN	PORTLAND, OR 97214-4657
0LXM2	LZR ELECTRONICS INC	8051 CESSNA AVENUE	GAITHERSBURG, MD 20879
22526	BERG ELECTRONICS INC	825 OLD TRAIL ROAD	ETTERS, PA 17319
24931	BERG ELECTRONICS INC	RF/COAXIAL DIV 2100 EARLYWOOD DR PO BOX 547	FRANKLIN, IN 46131
32997	BOURNS INC	TRIMPOT DIVISION 1200 COLUMBIA AVE	RIVERSIDE, CA 92507-2114
62786	HITACHI AMERICA LTD	HITACHI PLAZA 2000 SIERRA POINT PKWY	BRISBANE, CA 94005
75915	LITTELFUSE INC	800 E NORTHWEST HWY	DES PLAINES, IL 60016-3049
80009	TEKTRONIX INC	14150 SW KARL BRAUN DR PO BOX 500	BEAVERTON, OR 97077-0001
86928	SEASTROM MFG CO INC	456 SEASTROM STREET	TWIN FALLS, ID 83301
93907	CAMCAR DIV OF TEXTRON INC	ATTN: ALICIA SANFORD 516 18TH AVE	ROCKFORD, IL 611045181
TK1163	POLYCAST INC	9898 SW TIGARD ST	TIGARD, OR 97223

Replaceable Mechanical Parts

Manufacturers Cross Index (cont.)

Mfr. Code	Manufacturer	Address	City, state, zip code
TK1547	MOORE ELECTRONICS INC	19500 SW 90TH CT PO BOX 1030	TUALATIN, OR 97062
TK1617	CRAFT FACTORY PLASTICS	17145 SW ALEXANDER	ALOHA, OR 97007
TK1943	NEILSEN MANUFACTURING INC	3501 PORTLAND RD NE	SALEM, OR 97303
TK2548	XEROX CORPORATION	14181 SW MILLIKAN WAY	BEAVERTON, OR 97005
TK6106	R J SINGER INTERNATIONAL INC	4801 W JEFFERSON BLVD	LOS ANGELES, CA 90016

Replaceable Mechanical Parts List

Fig. & index number	Tektronix part number	Serial number effective	Serial number discount	Qty	Name & description	Mfr. code	Mfr. part number
8-1-1	202-0340-54			1	CASE,FRONT;FINISHED,POLY	TK1163	202-0340-54
-2	366-0754-01			1	KNOB;KNOB, BLACK,1.500 OD,0.250 ID,0.600	80009	366-0754-01
-3	210-0895-00			1	WASHER,SHLDR;0.255 ID X 0.375 OD X 0.105 THK,NYL	TK1617	210-0895-00
-4	311-2512-00			1	ENCODER,DIGITAL;PNL,CONTACTING,24 CYCLES PER REV,DETENTED,0.875 FMS,0.25 BUSHING	32997	ECLJ-B28-S E01019
-5	331-0545-00			1	LENS,FRONT;PLASTIC	80009	331-0545-00
-6	119-4795-00			1	KEY PAD;KEY PAD	80009	119-4795-00
-7	119-4792-00			1	KEYPAD;ELASTOMERIC,FRONT PANEL	80009	119-4792-00
-8				1	CKT BD ASSY;FRONT PANEL (SEE REPL A1)	80009	671-3101-00
-9	211-0408-00			14	SCR,ASSEM WSHR;4-40 X 0.250, PNH,STL,ZINC,T-10 TORX	0KB01	211-0408-00
-10	119-4794-00			1	SPEAKER;DYNAMIC,45MM DIA,8 OHM,600-7KHZ,MYLAR CONE,W/1" LEADS,LZR 45RM	0LXM2	45RM-T
-11	348-1414-00			1	GASKET;SPEAKER,POFORN,DUROMETER	80009	348-1414-00
-12	348-1413-01			1	GASKET;CASE GASKET,BONDED	80009	348-1413-01
8-2-13	119-4793-00			1	DISPLAY MODULE,LCD,240 X 128, DOT MATRIX,EL BACKLIGHT,126W X 71H MM VIEWING AREA	62786	LMG6401PLGE

Replaceable Mechanical Parts

Replaceable Mechanical Parts List (cont.)

Fig. & index number	Tektronix part number	Serial number effective	Serial number discount	Qty	Name & description	Mfr. code	Mfr. part number
-14	211-0408-00			4	SCR,ASSEM WSHR,4-40 X 0.250, PNH,STL,ZINC,T-10 TORX	0KB01	211-0408-00
-15	211-0408-00			8	SCR,ASSEM WSHR,4-40 X 0.250, PNH,STL,ZINC,T-10 TORX	0KB01	211-0408-00
-16	_____			1	CIRCUIT BD ASSY:PROCESSOR & POWER SUPPLY (SEE REPL A2/A3)	80009	671-4422-00
-17	211-0370-00			17	SCREW,MACHINE 4-40 X 0.5,FLH,TORX T7	0KB01	ORDER BY DESCRIPTION
-18	_____			1	SHIELD,ELEC:ANALOG CONVERTER,ALUM	80009	337-3994-01
-19	_____			1	CIRCUIT BD ASSY:ANALOG CONVERTOR/FILTER (SEE REPL A2/A3)	80009	672-0392-01
-20	_____			1	SHIELD,ELEC:ANALOG CONVERTER,4.490 X 9.610	TK1943	337-4146-00
8-3-21	348-1548-00			1	SHIELD,ELEC:EMC MAIN BODY 0.036 CRS,CONN:BKT 0.03G EGS	TK1943	348-1548-00
-22	211-0722-00			4	SCREW,MACHINE:6-32 X 0.250, PNH,STL,CDPL,TORX T-15	0KB01	ORDER BY DESCRIPTION
-23	346-0273-00			1	HANDLE STRAP:2-1 1/2 INCH A.C.W. MOLDED STRAP,NYLON WEBBING 1-1 1/2 INCH,BLACK	80009	346-0273-00
-24	_____			1	CIRCUIT BD ASSY:BATTERY INTERCONNECT (SEE REPL A5)	80009	671-4210-00

Replaceable Mechanical Parts List (cont.)

Fig. & index number	Tektronix part number	Serial number effective	Serial number discount	Qty	Name & description	Mfr. code	Mfr. part number
-25	386-6984-00			1	PLATE,CONNECTOR RETENTION PLATE,0.036 EG STEEL	TK1943	386-6984-00
-26	211-0722-00			1	SCREW,MACHINE,6-32 X 0.250, PNH,STL,CDPL,TORX T-15	0KB01	ORDER BY DESCRIPTION
-27	210-0845-00			1	WASHER,FLAT,0.5 ID X 0.625 OD X 0.02,STL CD PL	86928	ORDER BY DESCRIPTION
-28	210-0122-00			1	LOCKWASHER,PHOSPHOR BRONZE PLATED IP23 (NICKEL) ID 0.512-0.505 OD 0.630-0.620 THICKNESS 0.022 NOTE:DIAMETER TO CLEAR 1/2	22526	LW101-3
-29	220-0203-00			1	HEXNUT,BRASS PLATED IP23 (NICKEL) ID THREAD 1/2-28 UNEF2B OD 0.562 THICKNESS 0.109	22526	HN100-4
-30	211-0408-00			1	SCR,ASSEM WSHR,4-40 X 0.250, PNH,STL,ZINC,T-10 TORX	0KB01	211-0408-00
-31	348-1416-00			1	GASKET,RS232	80009	348-1416-00
-32				1	CKT BD ASSY,BACK BOARD (SEE REPL A4)		
-33	200-4205-01			1	RS232 CAP	80009	200-4205-01
-34	211-0372-00			2	SCREW,MACHINE,4-40 X 0.312, PNH,STL,TORX T10	93907	B80-00020-00 3
-35	134-0250-00			1	PLUG,DC INPUT	80009	134-0250-00
-36	202-0341-54			1	CASE,BACK POLY	TK1163	202-0341-54

Replaceable Mechanical Parts

Replaceable Mechanical Parts List (cont.)

Fig. & index number	Tektronix part number	Serial number effective	Serial number discount	Qty	Name & description	Mfr. code	Mfr. part number
-37	RFMBAT			1	BATTERY PACK:9.6V,NICAD,2800MAH,8 C CELL IN A PACK,8 X 2 X 1	0DWW6	888-216-1
-38	386-6983-00			1	PANEL ASSY:BATTERY PANEL	TK1943	386-6983-00
-39	211-0858-00			10	SCREW,MACHINE:6-32 X 2.5, PNH,TORX T-15,STEEL	0KB01	211-0858-00
-40	348-1532-00			1	GASKET:SILICON RUBBER 50-60 DUR,CO-LOR:RED ID 0.495 OD 0.625 THICKNESS 0.062	22526	G100-14
	159-5000-00			2	FUSE:2.5A,125V,FAST,SMD,R459 02.5	75915	R459 02.5

Replaceable Mechanical Parts List (cont.)

Fig. & Index number	Tektronix part number	Serial number effective	Serial number discount	Qty	Name & description	Mfr. code	Mfr. part number
	016-1642-00			1	CASE, CARRYING	TK6106	016-1642-00
	061-4121-00			1	REFERENCE CARD; LAMINATED REFERENCE CARD	TK2548	061-4121-00
	070-9959-00			1	MANUAL, TECH USERS, W/DISK, V1.03, CSS151	TK2548	070-9959-00
	070-9960-01			1	MANUAL, INSTRUCTION, FW VER 2.10 & ABOVE	TK2548	070-9960-01
	103-0301-00				ADAPTOR, CONN.F SERIES, FEMALE TO FEMALE	24931	33A116-2
	119-4860-00			1	CIGARETTE LIGHTER ADAPTER, W/180CM CABLE	0GV90	X001746FC12 CP
	119-4855-00			1	POWER SUPPLY, EXTERNAL, WALL MOUNT, 18W, 120VAC 60HZ IN, 12VDC 1.5A OUT	0GV90	WD1E1500C12 CP
	174-3269-00			1	CA ASSY, RS-232 CRC, 8.26 AWG, 72.0 L, DSUB, FEMALE, 9 POS, W/JACK SCREWS BOTH	TK1547	S-389

Standard Accessories

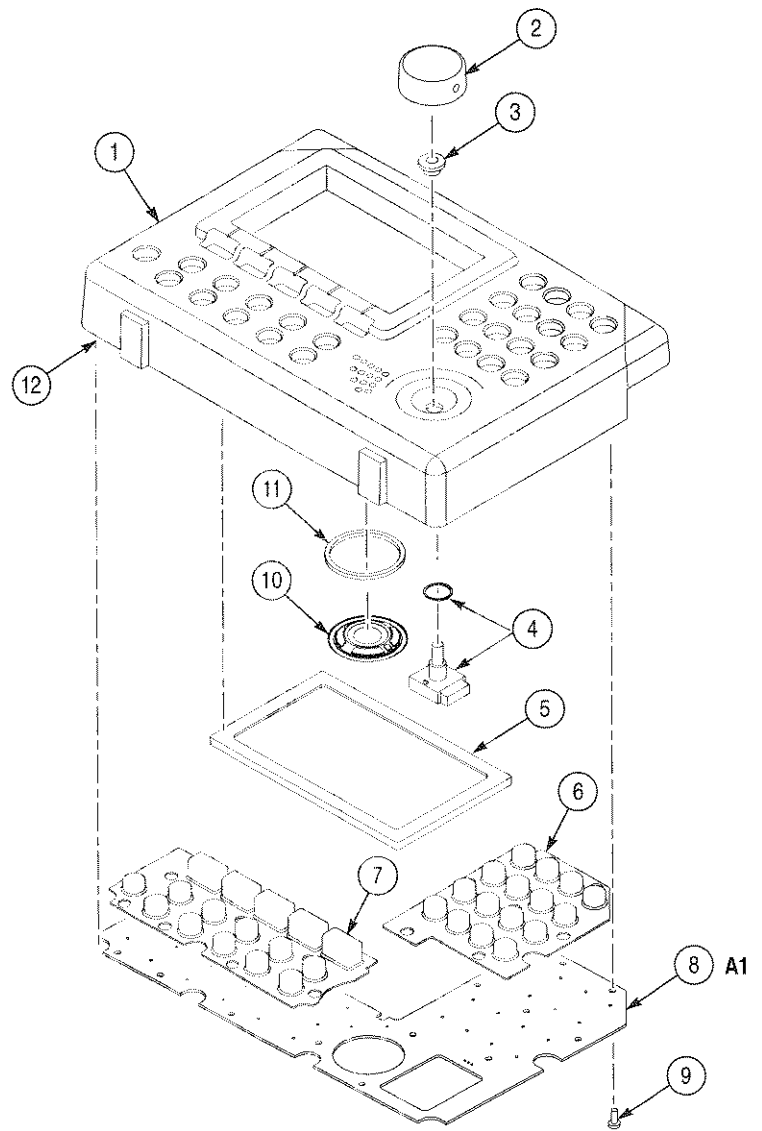

Figure 8-1: Exploded view, front case half

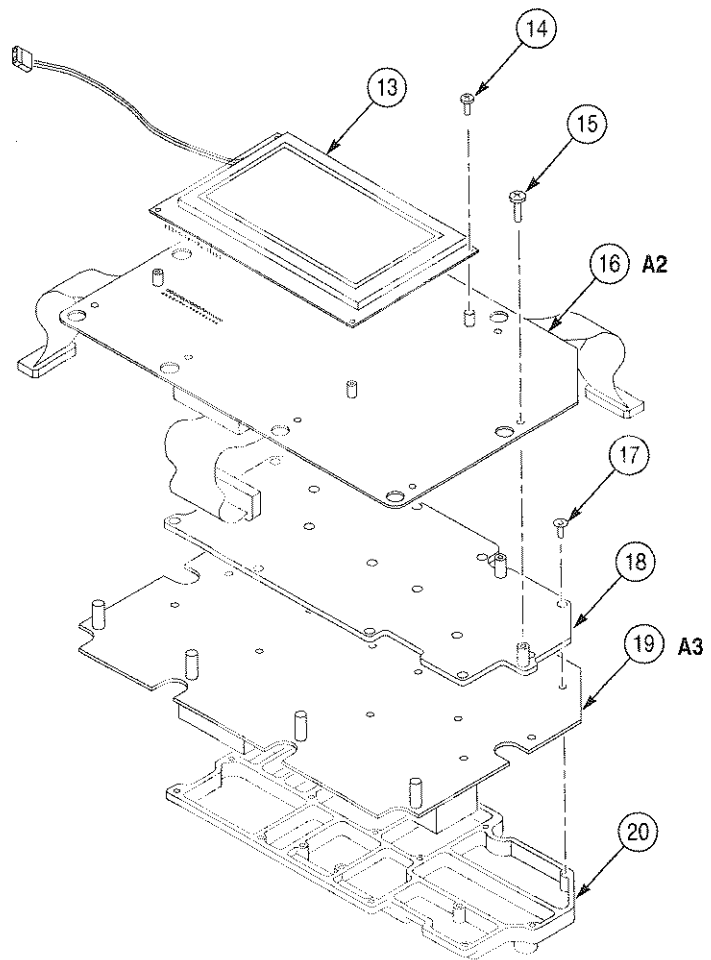

Figure 8-2: Exploded view, calibrated circuit board assembly and LCD display

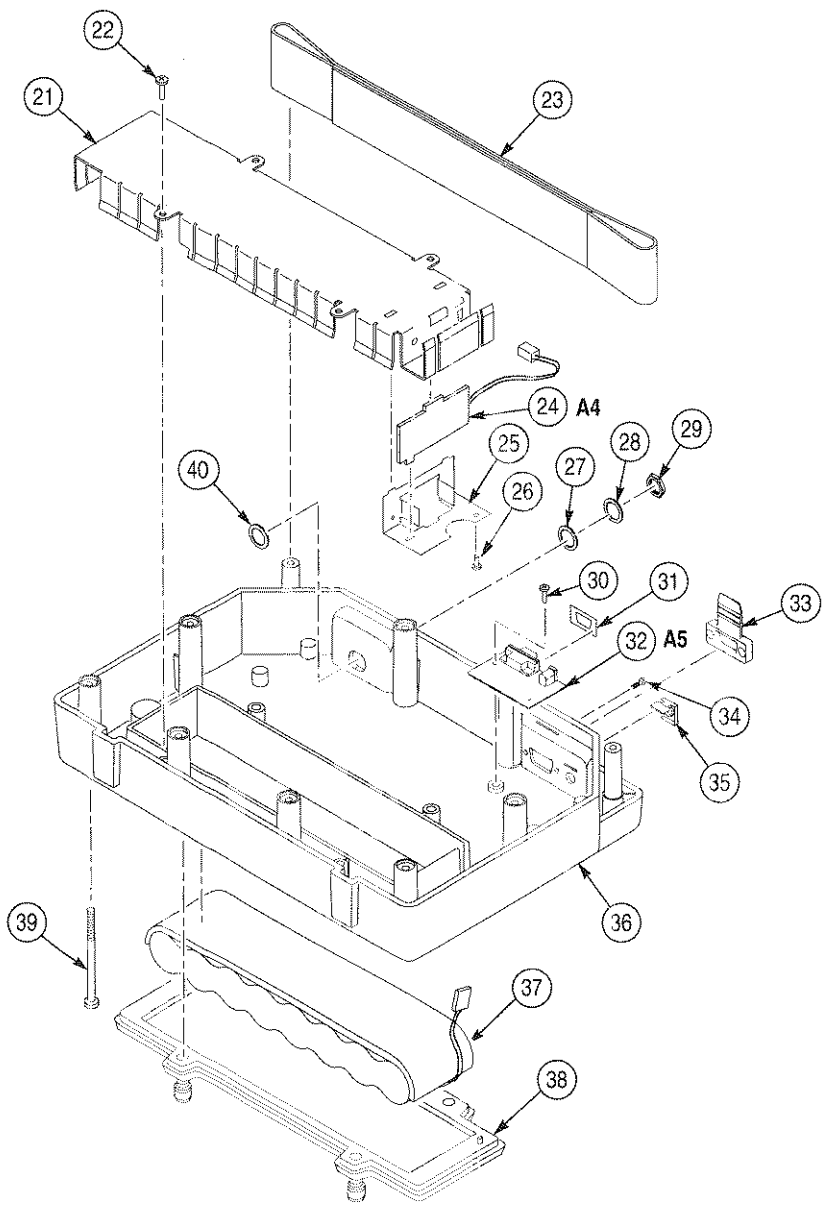

Figure 8-3: Exploded view, rear case half

Replaceable Mechanical Parts

Appendix A: Channel Tables

The SignalScout RFM151 RF analyzer contains eleven fixed channel tables. These channel tables can be edited, but cannot be deleted. The four fields that can be edited by the SignalScout RF analyzer menus are skip (yes/no), scrambled (yes/no), dwell time (short or long) and amplitude offset (in dB). The companion SignalScout CSS151 software package allows you to edit additional fields, as well as the create custom channel tables using the Channel Table Editor (CTLOADE). Fixed tables can be used as a basis for creating custom channel tables. Refer to the *SignalScout CSS151 Software User Manual* for instructions. You can also create custom channel tables by “cloning” the configuration of another SignalScout RF analyzer. See *Clone Configuration* on page 3–70.

The information given above each table in this section represents data that is the same for every channel in that table, including the defaults for the four editable fields. Blanks are provided to fill in new values. A blank table appears at the end of the section, so that you can create and maintain custom channel tables.

This appendix section defines the following eleven channel tables:

- CATV-STD
- CATV-500
- B-CAST
- CATV-IRC
- CATV-DK
- CHINA-DK
- EUR-BG
- EUR-DK
- EUR-I
- FRANCE-L
- JAPAN-M

CATV-Standard

Editable Fields – Defaults			
Amplitude Offset: <u>0.0 dB</u>	Scrambled: <u>No</u>	Dwell Time: <u>Short</u>	Skip: <u>No</u>
Fixed Fields			
Aural Offset: <u>4.5 MHz</u>	Second Aural Offset: <u>None</u>	C/N Bandwidth: <u>4.0 MHz</u>	

Table A-1: CATV-Standard

Channel Number	Frequency (MHz)	Channel Type	Channel Edge (MHz)	Skip Y/N	Scrambled Y/N	Dwell Time	Amplitude Offset
2	55.25	NTSC	-1.25	_____	_____	_____	_____
3	61.25	NTSC	-1.25	_____	_____	_____	_____
4	67.25	NTSC	-1.25	_____	_____	_____	_____
5	77.25	NTSC	-1.25	_____	_____	_____	_____
6	83.25	NTSC	-1.25	_____	_____	_____	_____
95	91.25	NTSC	-1.25	_____	_____	_____	_____
96	97.25	NTSC	-1.25	_____	_____	_____	_____
97	103.25	NTSC	-1.25	_____	_____	_____	_____
98	109.25	NTSC	-1.25	_____	_____	_____	_____
99	115.25	NTSC	-1.25	_____	_____	_____	_____
14	121.25	NTSC	-1.25	_____	_____	_____	_____
15	127.25	NTSC	-1.25	_____	_____	_____	_____
16	133.25	NTSC	-1.25	_____	_____	_____	_____
17	139.25	NTSC	-1.25	_____	_____	_____	_____
18	145.25	NTSC	-1.25	_____	_____	_____	_____
19	151.25	NTSC	-1.25	_____	_____	_____	_____
20	157.25	NTSC	-1.25	_____	_____	_____	_____
21	163.25	NTSC	-1.25	_____	_____	_____	_____
22	169.25	NTSC	-1.25	_____	_____	_____	_____
7	175.25	NTSC	-1.25	_____	_____	_____	_____
8	181.25	NTSC	-1.25	_____	_____	_____	_____
9	187.25	NTSC	-1.25	_____	_____	_____	_____
10	193.25	NTSC	-1.25	_____	_____	_____	_____
11	199.25	NTSC	-1.25	_____	_____	_____	_____
12	205.25	NTSC	-1.25	_____	_____	_____	_____
13	211.25	NTSC	-1.25	_____	_____	_____	_____
23	217.25	NTSC	-1.25	_____	_____	_____	_____

Table A-1: CATV-Standard (Cont.)

Channel Number	Frequency (MHz)	Channel Type	Channel Edge (MHz)	Skip Y/N	Scrambled Y/N	Dwell Time	Amplitude Offset
24	223.25	NTSC	-1.25	—	—	—	—
25	229.25	NTSC	-1.25	—	—	—	—
26	235.25	NTSC	-1.25	—	—	—	—
27	241.25	NTSC	-1.25	—	—	—	—
28	247.25	NTSC	-1.25	—	—	—	—
29	253.25	NTSC	-1.25	—	—	—	—
30	259.25	NTSC	-1.25	—	—	—	—
31	265.25	NTSC	-1.25	—	—	—	—
32	271.25	NTSC	-1.25	—	—	—	—
33	277.25	NTSC	-1.25	—	—	—	—
34	283.25	NTSC	-1.25	—	—	—	—
35	289.25	NTSC	-1.25	—	—	—	—
36	295.25	NTSC	-1.25	—	—	—	—
37	301.25	NTSC	-1.25	—	—	—	—
8	307.25	NTSC	-1.25	—	—	—	—
39	313.25	NTSC	-1.25	—	—	—	—
40	319.25	NTSC	-1.25	—	—	—	—
41	325.25	NTSC	-1.25	—	—	—	—
42	331.25	NTSC	-1.25	—	—	—	—
43	337.25	NTSC	-1.25	—	—	—	—
44	343.25	NTSC	-1.25	—	—	—	—
45	349.25	NTSC	-1.25	—	—	—	—
46	355.25	NTSC	-1.25	—	—	—	—
47	361.25	NTSC	-1.25	—	—	—	—
48	367.25	NTSC	-1.25	—	—	—	—
9	373.25	NTSC	-1.25	—	—	—	—
50	379.25	NTSC	-1.25	—	—	—	—
51	385.25	NTSC	-1.25	—	—	—	—
52	391.25	NTSC	-1.25	—	—	—	—
53	397.25	NTSC	-1.25	—	—	—	—
54	403.25	NTSC	-1.25	—	—	—	—
55	409.25	NTSC	-1.25	—	—	—	—
56	415.25	NTSC	-1.25	—	—	—	—
57	421.25	NTSC	-1.25	—	—	—	—

Appendix A: Channel Tables

Table A-1: CATV-Standard (Cont.)

Channel Number	Frequency (MHz)	Channel Type	Channel Edge (MHz)	Skip Y/N	Scrambled Y/N	Dwell Time	Amplitude Offset
58	427.25	NTSC	-1.25	—	—	—	—
59	433.25	NTSC	-1.25	—	—	—	—
60	439.25	NTSC	-1.25	—	—	—	—
61	445.25	NTSC	-1.25	—	—	—	—
62	451.25	NTSC	-1.25	—	—	—	—
63	457.25	NTSC	-1.25	—	—	—	—
64	463.25	NTSC	-1.25	—	—	—	—
65	469.25	NTSC	-1.25	—	—	—	—
66	475.25	NTSC	-1.25	—	—	—	—
67	481.25	NTSC	-1.25	—	—	—	—
68	487.25	NTSC	-1.25	—	—	—	—
69	493.25	NTSC	-1.25	—	—	—	—
70	499.25	NTSC	-1.25	—	—	—	—
71	505.25	NTSC	-1.25	—	—	—	—
72	511.25	NTSC	-1.25	—	—	—	—
73	517.25	NTSC	-1.25	—	—	—	—
74	523.25	NTSC	-1.25	—	—	—	—
75	529.25	NTSC	-1.25	—	—	—	—
76	535.25	NTSC	-1.25	—	—	—	—
77	541.25	NTSC	-1.25	—	—	—	—
78	547.25	NTSC	-1.25	—	—	—	—
79	553.25	NTSC	-1.25	—	—	—	—
80	559.25	NTSC	-1.25	—	—	—	—
81	565.25	NTSC	-1.25	—	—	—	—
82	571.25	NTSC	-1.25	—	—	—	—
83	577.25	NTSC	-1.25	—	—	—	—
84	583.25	NTSC	-1.25	—	—	—	—
85	589.25	NTSC	-1.25	—	—	—	—
86	595.25	NTSC	-1.25	—	—	—	—
87	601.25	NTSC	-1.25	—	—	—	—
88	607.25	NTSC	-1.25	—	—	—	—
89	613.25	NTSC	-1.25	—	—	—	—
90	619.25	NTSC	-1.25	—	—	—	—
91	625.25	NTSC	-1.25	—	—	—	—

Table A-1: CATV-Standard (Cont.)

Channel Number	Frequency (MHz)	Channel Type	Channel Edge (MHz)	Skip Y/N	Scrambled Y/N	Dwell Time	Amplitude Offset
92	631.25	NTSC	-1.25				
93	637.25	NTSC	-1.25				
94	643.25	NTSC	-1.25				
100	649.25	NTSC	-1.25				
101	655.25	NTSC	-1.25				
102	661.25	NTSC	-1.25				
103	667.25	NTSC	-1.25				
104	673.25	NTSC	-1.25				
105	679.25	NTSC	-1.25				
106	685.25	NTSC	-1.25				
107	691.25	NTSC	-1.25				
108	697.25	NTSC	-1.25				
109	703.25	NTSC	-1.25				
110	709.25	NTSC	-1.25				
111	715.25	NTSC	-1.25				
112	721.25	NTSC	-1.25				
113	727.25	NTSC	-1.25				
114	733.25	NTSC	-1.25				
115	739.25	NTSC	-1.25				
116	745.25	NTSC	-1.25				
117	751.25	NTSC	-1.25				
118	757.25	NTSC	-1.25				
119	763.25	NTSC	-1.25				
120	769.25	NTSC	-1.25				
121	775.25	NTSC	-1.25				
122	781.25	NTSC	-1.25				
123	787.25	NTSC	-1.25				
124	793.25	NTSC	-1.25				
125	799.25	NTSC	-1.25				
126	805.25	NTSC	-1.25				
127	811.25	NTSC	-1.25				
128	817.25	NTSC	-1.25				
129	823.25	NTSC	-1.25				
130	829.25	NTSC	-1.25				

Appendix A: Channel Tables

Table A-1: CATV-Standard (Cont.)

Channel Number	Frequency (MHz)	Channel Type	Channel Edge (MHz)	Skip Y/N	Scrambled Y/N	Dwell Time	Amplitude Offset
131	835.25	NTSC	-1.25	—	—	—	—
132	841.25	NTSC	-1.25	—	—	—	—
133	847.25	NTSC	-1.25	—	—	—	—
134	853.25	NTSC	-1.25	—	—	—	—
135	859.25	NTSC	-1.25	—	—	—	—
136	865.25	NTSC	-1.25	—	—	—	—
137	871.25	NTSC	-1.25	—	—	—	—
138	877.25	NTSC	-1.25	—	—	—	—
139	883.25	NTSC	-1.25	—	—	—	—
140	889.25	NTSC	-1.25	—	—	—	—
141	895.25	NTSC	-1.25	—	—	—	—
142	901.25	NTSC	-1.25	—	—	—	—
143	907.25	NTSC	-1.25	—	—	—	—
144	913.25	NTSC	-1.25	—	—	—	—
145	919.25	NTSC	-1.25	—	—	—	—
146	925.25	NTSC	-1.25	—	—	—	—
147	931.25	NTSC	-1.25	—	—	—	—
148	937.25	NTSC	-1.25	—	—	—	—
149	943.25	NTSC	-1.25	—	—	—	—
150	949.25	NTSC	-1.25	—	—	—	—
151	955.25	NTSC	-1.25	—	—	—	—
152	961.25	NTSC	-1.25	—	—	—	—
153	967.25	NTSC	-1.25	—	—	—	—
154	973.25	NTSC	-1.25	—	—	—	—
155	979.25	NTSC	-1.25	—	—	—	—
156	985.25	NTSC	-1.25	—	—	—	—
157	991.25	NTSC	-1.25	—	—	—	—
158	997.25	NTSC	-1.25	—	—	—	—
159	1003.25	NTSC	-1.25	—	—	—	—
160	1009.25	NTSC	-1.25	—	—	—	—
161	1015.25	NTSC	-1.25	—	—	—	—
162	1021.25	NTSC	-1.25	—	—	—	—
163	1027.25	NTSC	-1.25	—	—	—	—
164	1033.25	NTSC	-1.25	—	—	—	—

Table A-1: CATV-Standard (Cont.)

Channel Number	Frequency (MHz)	Channel Type	Channel Edge (MHz)	Skip Y/N	Scrambled Y/N	Dwell Time	Amplitude Offset
165	1039.25	NTSC	-1.25	—	—	—	—
166	1045.25	NTSC	-1.25	—	—	—	—
167	1051.25	NTSC	-1.25	—	—	—	—
168	1057.25	NTSC	-1.25	—	—	—	—
169	1063.25	NTSC	-1.25	—	—	—	—
170	1069.25	NTSC	-1.25	—	—	—	—

CATV-500 Channels

Editable Fields – Defaults			
Amplitude Offset: <u>0.0 dB</u>	Scrambled: <u>No</u>	Dwell Time: <u>Short</u>	Skip: <u>No</u>
Fixed Fields			
Aural Offset: <u>4.5 MHz</u>	Second Aural Offset: <u>None</u>	C/N Bandwidth: <u>4.0 MHz</u>	

Table A-2: CATV-500 Standard

Channel Number	Frequency (MHz)	Channel Type	Channel Edge (MHz)	Skip Y/N	Scrambled Y/N	Dwell Time	Amplitude Offset
93	43.00	NTSC	-1.25	---	---	---	---
94	49.00	NTSC	-1.25	---	---	---	---
2	55.25	NTSC	-1.25	---	---	---	---
3	61.25	NTSC	-1.25	---	---	---	---
4	67.25	NTSC	-1.25	---	---	---	---
5	77.25	NTSC	-1.25	---	---	---	---
6	83.25	NTSC	-1.25	---	---	---	---
95	91.25	NTSC	-1.25	---	---	---	---
96	97.25	NTSC	-1.25	---	---	---	---
97	103.25	NTSC	-1.25	---	---	---	---
98	109.25	NTSC	-1.25	---	---	---	---
99	115.25	NTSC	-1.25	---	---	---	---
14	121.25	NTSC	-1.25	---	---	---	---
15	127.25	NTSC	-1.25	---	---	---	---
16	133.25	NTSC	-1.25	---	---	---	---
17	139.25	NTSC	-1.25	---	---	---	---
18	145.25	NTSC	-1.25	---	---	---	---
19	151.25	NTSC	-1.25	---	---	---	---
20	157.25	NTSC	-1.25	---	---	---	---
21	163.25	NTSC	-1.25	---	---	---	---
22	169.25	NTSC	-1.25	---	---	---	---
7	175.25	NTSC	-1.25	---	---	---	---
8	181.25	NTSC	-1.25	---	---	---	---
9	187.25	NTSC	-1.25	---	---	---	---
10	193.25	NTSC	-1.25	---	---	---	---
11	199.25	NTSC	-1.25	---	---	---	---

Table A-2: CATV-500 Standard (Cont.)

Channel Number	Frequency (MHz)	Channel Type	Channel Edge (MHz)	Skip Y/N	Scrambled Y/N	Dwell Time	Amplitude Offset
12	205.25	NTSC	-1.25				
13	211.25	NTSC	-1.25				
23	217.25	NTSC	-1.25				
24	223.25	NTSC	-1.25				
25	229.25	NTSC	-1.25				
26	235.25	NTSC	-1.25				
27	241.25	NTSC	-1.25				
28	247.25	NTSC	-1.25				
29	253.25	NTSC	-1.25				
30	259.25	NTSC	-1.25				
31	265.25	NTSC	-1.25				
32	271.25	NTSC	-1.25				
33	277.25	NTSC	-1.25				
34	283.25	NTSC	-1.25				
35	289.25	NTSC	-1.25				
36	295.25	NTSC	-1.25				
37	301.25	NTSC	-1.25				
8	307.25	NTSC	-1.25				
39	313.25	NTSC	-1.25				
40	319.25	NTSC	-1.25				
41	325.25	NTSC	-1.25				
42	331.25	NTSC	-1.25				
43	337.25	NTSC	-1.25				
44	343.25	NTSC	-1.25				
45	349.25	NTSC	-1.25				
46	355.25	NTSC	-1.25				
47	361.25	NTSC	-1.25				
48	367.25	NTSC	-1.25				
9	373.25	NTSC	-1.25				
50	379.25	NTSC	-1.25				
51	385.25	NTSC	-1.25				
52	391.25	NTSC	-1.25				
53	397.25	NTSC	-1.25				
54	403.25	NTSC	-1.25				

Appendix A: Channel Tables

Table A-2: CATV-500 Standard (Cont.)

Channel Number	Frequency (MHz)	Channel Type	Channel Edge (MHz)	Skip Y/N	Scrambled Y/N	Dwell Time	Amplitude Offset
55	409.25	NTSC	-1.25	---	---	---	---
56	415.25	NTSC	-1.25	---	---	---	---
57	421.25	NTSC	-1.25	---	---	---	---
58	427.25	NTSC	-1.25	---	---	---	---
59	433.25	NTSC	-1.25	---	---	---	---
60	439.25	NTSC	-1.25	---	---	---	---
61	445.25	NTSC	-1.25	---	---	---	---
62	451.25	NTSC	-1.25	---	---	---	---
63	457.25	NTSC	-1.25	---	---	---	---
64	463.25	NTSC	-1.25	---	---	---	---
65	469.25	NTSC	-1.25	---	---	---	---
66	475.25	NTSC	-1.25	---	---	---	---
67	481.25	NTSC	-1.25	---	---	---	---
68	487.25	NTSC	-1.25	---	---	---	---
69	493.25	NTSC	-1.25	---	---	---	---
70	499.25	NTSC	-1.25	---	---	---	---
71	505.25	NTSC	-1.25	---	---	---	---
72	511.25	NTSC	-1.25	---	---	---	---

Broadcast channels

Editable Fields – Defaults			
Amplitude Offset: <u>0.0 dB</u>	Scrambled: <u>No</u>	Dwell Time: <u>Short</u>	Skip: <u>No</u>
Fixed Fields			
Aural Offset: <u>4.5 MHz</u>	Second Aural Offset: <u>None</u>	C/N Bandwidth: <u>4.0 MHz</u>	

Table A-3: Broadcast channels

Channel Number	Frequency (MHz)	Channel Type	Channel Edge (MHz)	Skip Y/N	Scrambled Y/N	Dwell Time	Amplitude Offset
2	55.25	NTSC	-1.25				
3	61.25	NTSC	-1.25				
4	67.25	NTSC	-1.25				
5	77.25	NTSC	-1.25				
6	83.25	NTSC	-1.25				
7	175.25	NTSC	-1.25				
8	181.25	NTSC	-1.25				
9	187.25	NTSC	-1.25				
10	193.25	NTSC	-1.25				
11	199.25	NTSC	-1.25				
12	205.25	NTSC	-1.25				
13	211.25	NTSC	-1.25				
14	471.25	NTSC	-1.25				
15	477.25	NTSC	-1.25				
16	483.25	NTSC	-1.25				
17	489.25	NTSC	-1.25				
18	495.25	NTSC	-1.25				
19	501.25	NTSC	-1.25				
20	507.25	NTSC	-1.25				
21	513.25	NTSC	-1.25				
22	519.25	NTSC	-1.25				
23	525.25	NTSC	-1.25				
24	531.25	NTSC	-1.25				
25	537.25	NTSC	-1.25				
26	543.25	NTSC	-1.25				
27	549.25	NTSC	-1.25				

Appendix A: Channel Tables

Table A-3: Broadcast channels (Cont.)

Channel Number	Frequency (MHz)	Channel Type	Channel Edge (MHz)	Skip Y/N	Scrambled Y/N	Dwell Time	Amplitude Offset
28	555.25	NTSC	-1.25	—	—	—	—
29	561.25	NTSC	-1.25	—	—	—	—
30	567.25	NTSC	-1.25	—	—	—	—
31	573.25	NTSC	-1.25	—	—	—	—
32	579.25	NTSC	-1.25	—	—	—	—
33	585.25	NTSC	-1.25	—	—	—	—
34	591.25	NTSC	-1.25	—	—	—	—
35	597.25	NTSC	-1.25	—	—	—	—
36	603.25	NTSC	-1.25	—	—	—	—
37	609.25	NTSC	-1.25	—	—	—	—
38	615.25	NTSC	-1.25	—	—	—	—
39	621.25	NTSC	-1.25	—	—	—	—
40	627.25	NTSC	-1.25	—	—	—	—
41	633.25	NTSC	-1.25	—	—	—	—
42	639.25	NTSC	-1.25	—	—	—	—
43	645.25	NTSC	-1.25	—	—	—	—
44	651.25	NTSC	-1.25	—	—	—	—
45	657.25	NTSC	-1.25	—	—	—	—
46	663.25	NTSC	-1.25	—	—	—	—
47	669.25	NTSC	-1.25	—	—	—	—
48	675.25	NTSC	-1.25	—	—	—	—
49	681.25	NTSC	-1.25	—	—	—	—
50	687.25	NTSC	-1.25	—	—	—	—
51	693.25	NTSC	-1.25	—	—	—	—
52	699.25	NTSC	-1.25	—	—	—	—
53	705.25	NTSC	-1.25	—	—	—	—
54	711.25	NTSC	-1.25	—	—	—	—
55	717.25	NTSC	-1.25	—	—	—	—
56	723.25	NTSC	-1.25	—	—	—	—
57	729.25	NTSC	-1.25	—	—	—	—
58	735.25	NTSC	-1.25	—	—	—	—
59	741.25	NTSC	-1.25	—	—	—	—
60	747.25	NTSC	-1.25	—	—	—	—
61	753.25	NTSC	-1.25	—	—	—	—

Table A-3: Broadcast channels (Cont.)

Channel Number	Frequency (MHz)	Channel Type	Channel Edge (MHz)	Skip Y/N	Scrambled Y/N	Dwell Time	Amplitude Offset
62	759.25	NTSC	-1.25				
63	765.25	NTSC	-1.25				
64	771.25	NTSC	-1.25				
65	777.25	NTSC	-1.25				
66	783.25	NTSC	-1.25				
67	789.25	NTSC	-1.25				
68	795.25	NTSC	-1.25				
69	801.25	NTSC	-1.25				
70	807.25	NTSC	-1.25				
71	813.25	NTSC	-1.25				
72	819.25	NTSC	-1.25				
73	825.25	NTSC	-1.25				
74	831.25	NTSC	-1.25				
75	837.25	NTSC	-1.25				
76	843.25	NTSC	-1.25				
77	849.25	NTSC	-1.25				
78	855.25	NTSC	-1.25				
79	861.25	NTSC	-1.25				
80	867.25	NTSC	-1.25				
81	873.25	NTSC	-1.25				
82	879.25	NTSC	-1.25				
83	885.25	NTSC	-1.25				

CATV-HRC Channels

Editable Fields – Defaults			
Amplitude Offset: <u>0.0 dB</u>	Scrambled: <u>No</u>	Dwell Time: <u>Short</u>	Skip: <u>No</u>
Fixed Fields			
Aural Offset: <u>4.5 MHz</u>	Second Aural Offset: <u>None</u>	C/N Bandwidth: <u>4.0 MHz</u>	

Table A-4: CATV-HRC channels

Channel Number	Frequency (MHz)	Channel Type	Channel Edge (MHz)	Skip Y/N	Scrambled Y/N	Dwell Time	Amplitude Offset
2	54.00	NTSC	-1.25	___	___	___	___
3	60.00	NTSC	-1.25	___	___	___	___
4	66.00	NTSC	-1.25	___	___	___	___
1	72.00	NTSC	-1.25	___	___	___	___
5	78.00	NTSC	-1.25	___	___	___	___
6	84.00	NTSC	-1.25	___	___	___	___
95	90.00	NTSC	-1.25	___	___	___	___
96	96.00	NTSC	-1.25	___	___	___	___
97	102.01	NTSC	-1.25	___	___	___	___
98	108.01	NTSC	-1.25	___	___	___	___
99	114.01	NTSC	-1.25	___	___	___	___
14	120.01	NTSC	-1.25	___	___	___	___
15	126.01	NTSC	-1.25	___	___	___	___
16	132.01	NTSC	-1.25	___	___	___	___
17	138.01	NTSC	-1.25	___	___	___	___
18	144.01	NTSC	-1.25	___	___	___	___
19	150.01	NTSC	-1.25	___	___	___	___
20	156.01	NTSC	-1.25	___	___	___	___
21	162.01	NTSC	-1.25	___	___	___	___
22	168.01	NTSC	-1.25	___	___	___	___
7	174.01	NTSC	-1.25	___	___	___	___
8	180.01	NTSC	-1.25	___	___	___	___
9	186.01	NTSC	-1.25	___	___	___	___
10	192.01	NTSC	-1.25	___	___	___	___
11	198.01	NTSC	-1.25	___	___	___	___
12	204.01	NTSC	-1.25	___	___	___	___

Table A-4: CATV-HRC channels (Cont.)

Channel Number	Frequency (MHz)	Channel Type	Channel Edge (MHz)	Skip Y/N	Scrambled Y/N	Dwell Time	Amplitude Offset
13	210.01	NTSC	-1.25	---	---	---	---
23	216.01	NTSC	-1.25	---	---	---	---
24	222.01	NTSC	-1.25	---	---	---	---
25	228.01	NTSC	-1.25	---	---	---	---
26	234.01	NTSC	-1.25	---	---	---	---
27	240.01	NTSC	-1.25	---	---	---	---
28	246.01	NTSC	-1.25	---	---	---	---
29	252.01	NTSC	-1.25	---	---	---	---
30	258.01	NTSC	-1.25	---	---	---	---
31	264.01	NTSC	-1.25	---	---	---	---
32	270.01	NTSC	-1.25	---	---	---	---
33	276.01	NTSC	-1.25	---	---	---	---
34	282.01	NTSC	-1.25	---	---	---	---
35	288.01	NTSC	-1.25	---	---	---	---
36	294.01	NTSC	-1.25	---	---	---	---
37	300.01	NTSC	-1.25	---	---	---	---
38	306.02	NTSC	-1.25	---	---	---	---
39	312.02	NTSC	-1.25	---	---	---	---
40	318.02	NTSC	-1.25	---	---	---	---
41	324.02	NTSC	-1.25	---	---	---	---
42	330.02	NTSC	-1.25	---	---	---	---
43	336.02	NTSC	-1.25	---	---	---	---
44	342.02	NTSC	-1.25	---	---	---	---
45	348.02	NTSC	-1.25	---	---	---	---
46	354.02	NTSC	-1.25	---	---	---	---
47	360.02	NTSC	-1.25	---	---	---	---
48	366.02	NTSC	-1.25	---	---	---	---
49	372.02	NTSC	-1.25	---	---	---	---
50	378.02	NTSC	-1.25	---	---	---	---
51	384.02	NTSC	-1.25	---	---	---	---
52	390.02	NTSC	-1.25	---	---	---	---
53	396.02	NTSC	-1.25	---	---	---	---
54	402.02	NTSC	-1.25	---	---	---	---
55	408.02	NTSC	-1.25	---	---	---	---

Appendix A: Channel Tables

Table A-4: CATV-HRC channels (Cont.)

Channel Number	Frequency (MHz)	Channel Type	Channel Edge (MHz)	Skip Y/N	Scrambled Y/N	Dwell Time	Amplitude Offset
56	414.02	NTSC	-1.25	---	---	---	---
57	420.02	NTSC	-1.25	---	---	---	---
58	426.02	NTSC	-1.25	---	---	---	---
59	432.02	NTSC	-1.25	---	---	---	---
60	438.02	NTSC	-1.25	---	---	---	---
61	444.02	NTSC	-1.25	---	---	---	---
62	450.02	NTSC	-1.25	---	---	---	---
63	456.02	NTSC	-1.25	---	---	---	---
64	462.02	NTSC	-1.25	---	---	---	---
65	468.02	NTSC	-1.25	---	---	---	---
66	474.02	NTSC	-1.25	---	---	---	---
67	480.02	NTSC	-1.25	---	---	---	---
68	486.02	NTSC	-1.25	---	---	---	---
69	492.02	NTSC	-1.25	---	---	---	---
70	498.02	NTSC	-1.25	---	---	---	---
71	504.02	NTSC	-1.25	---	---	---	---
72	510.03	NTSC	-1.25	---	---	---	---
73	516.03	NTSC	-1.25	---	---	---	---
74	522.03	NTSC	-1.25	---	---	---	---
75	528.03	NTSC	-1.25	---	---	---	---
76	534.03	NTSC	-1.25	---	---	---	---
77	540.03	NTSC	-1.25	---	---	---	---
78	546.03	NTSC	-1.25	---	---	---	---
79	552.03	NTSC	-1.25	---	---	---	---
80	558.03	NTSC	-1.25	---	---	---	---
81	564.03	NTSC	-1.25	---	---	---	---
82	570.03	NTSC	-1.25	---	---	---	---
3	576.03	NTSC	-1.25	---	---	---	---
84	582.03	NTSC	-1.25	---	---	---	---
85	588.03	NTSC	-1.25	---	---	---	---
86	594.03	NTSC	-1.25	---	---	---	---
87	600.03	NTSC	-1.25	---	---	---	---
88	606.03	NTSC	-1.25	---	---	---	---
89	612.03	NTSC	-1.25	---	---	---	---

Table A-4: CATV-HRC channels (Cont.)

Channel Number	Frequency (MHz)	Channel Type	Channel Edge (MHz)	Skip Y/N	Scrambled Y/N	Dwell Time	Amplitude Offset
90	618.03	NTSC	-1.25	—	—	—	—
91	624.03	NTSC	-1.25	—	—	—	—
92	630.03	NTSC	-1.25	—	—	—	—
93	636.03	NTSC	-1.25	—	—	—	—
94	642.03	NTSC	-1.25	—	—	—	—

CATV-IRC Channels

Editable Fields – Defaults			
Amplitude Offset: <u>0.0 dB</u>	Scrambled: <u>No</u>	Dwell Time: <u>Short</u>	Skip: <u>No</u>
Fixed Fields			
Aural Offset: <u>4.5 MHz</u>	Second Aural Offset: <u>None</u>	C/N Bandwidth: <u>4.0 MHz</u>	

Table A-5: CATV-IRC channels

Channel Number	Frequency (MHz)	Channel Type	Channel Edge (MHz)	Skip Y/N	Scrambled Y/N	Dwell Time	Amplitude Offset
2	55.25	NTSC	-1.25	_____	_____	_____	_____
3	61.25	NTSC	-1.25	_____	_____	_____	_____
4	67.25	NTSC	-1.25	_____	_____	_____	_____
5	79.25	NTSC	-1.25	_____	_____	_____	_____
6	85.25	NTSC	-1.25	_____	_____	_____	_____
95	91.25	NTSC	-1.25	_____	_____	_____	_____
96	97.25	NTSC	-1.25	_____	_____	_____	_____
97	103.25	NTSC	-1.25	_____	_____	_____	_____
98	109.25	NTSC	-1.25	_____	_____	_____	_____
99	115.25	NTSC	-1.25	_____	_____	_____	_____
14	121.25	NTSC	-1.25	_____	_____	_____	_____
15	127.25	NTSC	-1.25	_____	_____	_____	_____
16	133.25	NTSC	-1.25	_____	_____	_____	_____
17	139.25	NTSC	-1.25	_____	_____	_____	_____
18	145.25	NTSC	-1.25	_____	_____	_____	_____
19	151.25	NTSC	-1.25	_____	_____	_____	_____
20	157.25	NTSC	-1.25	_____	_____	_____	_____
21	163.25	NTSC	-1.25	_____	_____	_____	_____
22	169.25	NTSC	-1.25	_____	_____	_____	_____
7	175.25	NTSC	-1.25	_____	_____	_____	_____
8	181.25	NTSC	-1.25	_____	_____	_____	_____
9	187.25	NTSC	-1.25	_____	_____	_____	_____
10	193.25	NTSC	-1.25	_____	_____	_____	_____
11	199.25	NTSC	-1.25	_____	_____	_____	_____
12	205.25	NTSC	-1.25	_____	_____	_____	_____
13	211.25	NTSC	-1.25	_____	_____	_____	_____

Table A-5: CATV-IRC channels (Cont.)

Channel Number	Frequency (MHz)	Channel Type	Channel Edge (MHz)	Skip Y/N	Scrambled Y/N	Dwell Time	Amplitude Offset
23	217.25	NTSC	-1.25				
24	223.25	NTSC	-1.25				
25	229.25	NTSC	-1.25				
26	235.25	NTSC	-1.25				
27	241.25	NTSC	-1.25				
28	247.25	NTSC	-1.25				
29	253.25	NTSC	-1.25				
30	259.25	NTSC	-1.25				
31	265.25	NTSC	-1.25				
32	271.25	NTSC	-1.25				
33	277.25	NTSC	-1.25				
34	283.25	NTSC	-1.25				
35	289.25	NTSC	-1.25				
36	295.25	NTSC	-1.25				
37	301.25	NTSC	-1.25				
38	307.25	NTSC	-1.25				
39	313.25	NTSC	-1.25				
40	319.25	NTSC	-1.25				
41	325.25	NTSC	-1.25				
42	331.25	NTSC	-1.25				
43	337.25	NTSC	-1.25				
44	343.25	NTSC	-1.25				
45	349.25	NTSC	-1.25				
46	355.25	NTSC	-1.25				
47	361.25	NTSC	-1.25				
48	367.25	NTSC	-1.25				
49	373.25	NTSC	-1.25				
50	379.25	NTSC	-1.25				
51	385.25	NTSC	-1.25				
52	391.25	NTSC	-1.25				
53	397.25	NTSC	-1.25				
54	403.25	NTSC	-1.25				
55	409.25	NTSC	-1.25				
56	415.25	NTSC	-1.25				

Appendix A: Channel Tables

Table A-5: CATV-IRC channels (Cont.)

Channel Number	Frequency (MHz)	Channel Type	Channel Edge (MHz)	Skip Y/N	Scrambled Y/N	Dwell Time	Amplitude Offset
57	421.25	NTSC	-1.25	---	---	---	---
58	427.25	NTSC	-1.25	---	---	---	---
59	433.25	NTSC	-1.25	---	---	---	---
60	439.25	NTSC	-1.25	---	---	---	---
61	445.25	NTSC	-1.25	---	---	---	---
62	451.25	NTSC	-1.25	---	---	---	---
63	457.25	NTSC	-1.25	---	---	---	---
64	463.25	NTSC	-1.25	---	---	---	---
65	469.25	NTSC	-1.25	---	---	---	---
66	475.25	NTSC	-1.25	---	---	---	---
67	481.25	NTSC	-1.25	---	---	---	---
68	487.25	NTSC	-1.25	---	---	---	---
69	493.25	NTSC	-1.25	---	---	---	---
70	499.25	NTSC	-1.25	---	---	---	---
71	505.25	NTSC	-1.25	---	---	---	---
72	511.25	NTSC	-1.25	---	---	---	---
73	517.25	NTSC	-1.25	---	---	---	---
74	523.25	NTSC	-1.25	---	---	---	---
75	529.25	NTSC	-1.25	---	---	---	---
76	535.25	NTSC	-1.25	---	---	---	---
77	541.25	NTSC	-1.25	---	---	---	---
78	547.25	NTSC	-1.25	---	---	---	---
79	553.25	NTSC	-1.25	---	---	---	---
80	559.25	NTSC	-1.25	---	---	---	---
81	565.25	NTSC	-1.25	---	---	---	---
82	571.25	NTSC	-1.25	---	---	---	---
83	577.25	NTSC	-1.25	---	---	---	---
84	583.25	NTSC	-1.25	---	---	---	---
85	589.25	NTSC	-1.25	---	---	---	---
86	595.25	NTSC	-1.25	---	---	---	---
87	601.25	NTSC	-1.25	---	---	---	---
88	607.25	NTSC	-1.25	---	---	---	---
89	613.25	NTSC	-1.25	---	---	---	---
90	619.25	NTSC	-1.25	---	---	---	---

Table A-5: CATV-IRC channels (Cont.)

Channel Number	Frequency (MHz)	Channel Type	Channel Edge (MHz)	Skip Y/N	Scrambled Y/N	Dwell Time	Amplitude Offset
91	625.25	NTSC	-1.25	—	—	—	—
92	631.25	NTSC	-1.25	—	—	—	—
93	637.25	NTSC	-1.25	—	—	—	—
94	643.25	NTSC	-1.25	—	—	—	—

China-DK Channels

Editable Fields – Defaults			
Amplitude Offset: <u>0.0 dB</u>	Scrambled: <u>No</u>	Dwell Time: <u>Short</u>	Skip: <u>No</u>
Fixed Fields			
Aural Offset: <u>6.5 MHz</u>	Second Aural Offset: <u>None</u>	C/N Bandwidth: <u>6.0 MHz</u>	

Table A-6: China-DK channels

Channel Number	Frequency (MHz)	Channel Type	Channel Edge (MHz)	Skip Y/N	Scrambled Y/N	Dwell Time	Amplitude Offset
101	49.75	PAL	-1.25	_____	_____	_____	_____
102	57.75	PAL	-1.25	_____	_____	_____	_____
103	65.75	PAL	-1.25	_____	_____	_____	_____
104	77.25	PAL	-1.25	_____	_____	_____	_____
105	85.25	PAL	-1.25	_____	_____	_____	_____
1	112.25	PAL	-1.25	_____	_____	_____	_____
2	120.25	PAL	-1.25	_____	_____	_____	_____
3	128.25	PAL	-1.25	_____	_____	_____	_____
4	136.25	PAL	-1.25	_____	_____	_____	_____
5	144.25	PAL	-1.25	_____	_____	_____	_____
6	152.25	PAL	-1.25	_____	_____	_____	_____
7	160.25	PAL	-1.25	_____	_____	_____	_____
106	168.25	PAL	-1.25	_____	_____	_____	_____
107	176.25	PAL	-1.25	_____	_____	_____	_____
108	184.25	PAL	-1.25	_____	_____	_____	_____
109	192.25	PAL	-1.25	_____	_____	_____	_____
110	200.25	PAL	-1.25	_____	_____	_____	_____
111	208.25	PAL	-1.25	_____	_____	_____	_____
112	216.25	PAL	-1.25	_____	_____	_____	_____
8	224.25	PAL	-1.25	_____	_____	_____	_____
9	232.25	PAL	-1.25	_____	_____	_____	_____
10	240.25	PAL	-1.25	_____	_____	_____	_____
11	248.25	PAL	-1.25	_____	_____	_____	_____
12	256.25	PAL	-1.25	_____	_____	_____	_____
13	264.25	PAL	-1.25	_____	_____	_____	_____
14	272.25	PAL	-1.25	_____	_____	_____	_____

Table A-6: China-DK channels (Cont.)

Channel Number	Frequency (MHz)	Channel Type	Channel Edge (MHz)	Skip Y/N	Scrambled Y/N	Dwell Time	Amplitude Offset
15	280.25	PAL	-1.25				
16	288.25	PAL	-1.25				
17	296.25	PAL	-1.25				
18	304.25	PAL	-1.25				
19	312.25	PAL	-1.25				
20	320.25	PAL	-1.25				
21	328.25	PAL	-1.25				
22	336.25	PAL	-1.25				
23	344.25	PAL	-1.25				
24	352.25	PAL	-1.25				
25	360.25	PAL	-1.25				
26	368.25	PAL	-1.25				
27	376.25	PAL	-1.25				
28	384.25	PAL	-1.25				
29	392.25	PAL	-1.25				
30	400.25	PAL	-1.25				
31	408.25	PAL	-1.25				
32	416.25	PAL	-1.25				
33	424.25	PAL	-1.25				
34	432.25	PAL	-1.25				
35	440.25	PAL	-1.25				

Europe-BG Channels

Editable Fields -- Defaults

Amplitude Offset: 0.0 dB Scrambled: No Dwell Time: Short Skip: No

Fixed Fields

Aural Offset: 5.5 MHz Second Aural Offset: None C/N Bandwidth: 5.0 MHz

Table A-7: Europe-BG channels

Channel Number	Frequency (MHz)	Channel Type	Channel Edge (MHz)	Skip Y/N	Scrambled Y/N	Dwell Time	Amplitude Offset
2	48.25	PAL	-1.25	_____	_____	_____	_____
3	55.25	PAL	-1.25	_____	_____	_____	_____
4	62.25	PAL	-1.25	_____	_____	_____	_____
81	105.25	PAL	-1.25	_____	_____	_____	_____
82	112.25	PAL	-1.25	_____	_____	_____	_____
83	119.25	PAL	-1.25	_____	_____	_____	_____
84	126.25	PAL	-1.25	_____	_____	_____	_____
85	133.25	PAL	-1.25	_____	_____	_____	_____
86	140.25	PAL	-1.25	_____	_____	_____	_____
87	147.25	PAL	-1.25	_____	_____	_____	_____
88	154.25	PAL	-1.25	_____	_____	_____	_____
89	161.25	PAL	-1.25	_____	_____	_____	_____
90	168.25	PAL	-1.25	_____	_____	_____	_____
5	175.25	PAL	-1.25	_____	_____	_____	_____
6	182.25	PAL	-1.25	_____	_____	_____	_____
7	189.25	PAL	-1.25	_____	_____	_____	_____
8	196.25	PAL	-1.25	_____	_____	_____	_____
9	203.25	PAL	-1.25	_____	_____	_____	_____
10	210.25	PAL	-1.25	_____	_____	_____	_____
11	217.25	PAL	-1.25	_____	_____	_____	_____
12	224.25	PAL	-1.25	_____	_____	_____	_____
91	231.25	PAL	-1.25	_____	_____	_____	_____
92	238.25	PAL	-1.25	_____	_____	_____	_____
93	245.25	PAL	-1.25	_____	_____	_____	_____
94	252.25	PAL	-1.25	_____	_____	_____	_____
95	259.25	PAL	-1.25	_____	_____	_____	_____

Table A-7: Europe-BG channels (Cont.)

Channel Number	Frequency (MHz)	Channel Type	Channel Edge (MHz)	Skip Y/N	Scrambled Y/N	Dwell Time	Amplitude Offset
96	266.25	PAL	-1.25	---	---	---	---
97	273.25	PAL	-1.25	---	---	---	---
98	280.25	PAL	-1.25	---	---	---	---
99	287.25	PAL	-1.25	---	---	---	---
100	294.25	PAL	-1.25	---	---	---	---
21	471.25	PAL	-1.25	---	---	---	---
22	479.25	PAL	-1.25	---	---	---	---
23	487.25	PAL	-1.25	---	---	---	---
24	495.25	PAL	-1.25	---	---	---	---
25	503.25	PAL	-1.25	---	---	---	---
26	511.25	PAL	-1.25	---	---	---	---
27	519.25	PAL	-1.25	---	---	---	---
28	527.25	PAL	-1.25	---	---	---	---
29	535.25	PAL	-1.25	---	---	---	---
30	543.25	PAL	-1.25	---	---	---	---
31	551.25	PAL	-1.25	---	---	---	---
32	559.25	PAL	-1.25	---	---	---	---
33	567.25	PAL	-1.25	---	---	---	---
34	575.25	PAL	-1.25	---	---	---	---
35	583.25	PAL	-1.25	---	---	---	---
36	591.25	PAL	-1.25	---	---	---	---
37	599.25	PAL	-1.25	---	---	---	---
38	607.25	PAL	-1.25	---	---	---	---
39	615.25	PAL	-1.25	---	---	---	---
40	623.25	PAL	-1.25	---	---	---	---
41	631.25	PAL	-1.25	---	---	---	---
42	639.25	PAL	-1.25	---	---	---	---
43	647.25	PAL	-1.25	---	---	---	---
44	655.25	PAL	-1.25	---	---	---	---
45	663.25	PAL	-1.25	---	---	---	---
46	671.25	PAL	-1.25	---	---	---	---
47	679.25	PAL	-1.25	---	---	---	---
48	687.25	PAL	-1.25	---	---	---	---
49	695.25	PAL	-1.25	---	---	---	---

Appendix A: Channel Tables

Table A-7: Europe-BG channels (Cont.)

Channel Number	Frequency (MHz)	Channel Type	Channel Edge (MHz)	Skip Y/N	Scrambled Y/N	Dwell Time	Amplitude Offset
50	703.25	PAL	-1.25	—	—	—	—
51	711.25	PAL	-1.25	—	—	—	—
52	719.25	PAL	-1.25	—	—	—	—
53	727.25	PAL	-1.25	—	—	—	—
54	735.25	PAL	-1.25	—	—	—	—
55	743.25	PAL	-1.25	—	—	—	—
56	751.25	PAL	-1.25	—	—	—	—
57	759.25	PAL	-1.25	—	—	—	—
58	767.25	PAL	-1.25	—	—	—	—
59	775.25	PAL	-1.25	—	—	—	—
60	783.25	PAL	-1.25	—	—	—	—
61	791.25	PAL	-1.25	—	—	—	—
62	799.25	PAL	-1.25	—	—	—	—
63	807.25	PAL	-1.25	—	—	—	—
64	815.25	PAL	-1.25	—	—	—	—
65	823.25	PAL	-1.25	—	—	—	—
66	831.25	PAL	-1.25	—	—	—	—
67	839.25	PAL	-1.25	—	—	—	—
68	847.25	PAL	-1.25	—	—	—	—

Europe-DK Channels

Editable Fields – Defaults

Amplitude Offset: 0.0 dB Scrambled: No Dwell Time: Short Skip: No

Fixed Fields

Aural Offset: 6.5 MHz Second Aural Offset: None C/N Bandwidth: 6.0 MHz

Table A-8: Europe-DK channels

Channel Number	Frequency (MHz)	Channel Type	Channel Edge (MHz)	Skip Y/N	Scrambled Y/N	Dwell Time	Amplitude Offset
101	49.75	PAL	-1.25	---	---	---	---
102	59.25	PAL	-1.25	---	---	---	---
103	77.25	PAL	-1.25	---	---	---	---
104	85.25	PAL	-1.25	---	---	---	---
105	93.25	PAL	-1.25	---	---	---	---
1	111.25	PAL	-1.25	---	---	---	---
2	119.25	PAL	-1.25	---	---	---	---
3	127.25	PAL	-1.25	---	---	---	---
4	135.25	PAL	-1.25	---	---	---	---
5	143.25	PAL	-1.25	---	---	---	---
6	151.25	PAL	-1.25	---	---	---	---
7	159.25	PAL	-1.25	---	---	---	---
8	167.25	PAL	-1.25	---	---	---	---
106	175.25	PAL	-1.25	---	---	---	---
107	183.25	PAL	-1.25	---	---	---	---
108	191.25	PAL	-1.25	---	---	---	---
109	199.25	PAL	-1.25	---	---	---	---
110	207.25	PAL	-1.25	---	---	---	---
111	215.25	PAL	-1.25	---	---	---	---
112	223.25	PAL	-1.25	---	---	---	---
9	231.25	PAL	-1.25	---	---	---	---
10	239.25	PAL	-1.25	---	---	---	---
11	247.25	PAL	-1.25	---	---	---	---
12	255.25	PAL	-1.25	---	---	---	---
13	263.25	PAL	-1.25	---	---	---	---
14	271.25	PAL	-1.25	---	---	---	---

Appendix A: Channel Tables

Table A-8: Europe-DK channels (Cont.)

Channel Number	Frequency (MHz)	Channel Type	Channel Edge (MHz)	Skip Y/N	Scrambled Y/N	Dwell Time	Amplitude Offset
15	279.25	PAL	-1.25	—	—	—	—
16	287.25	PAL	-1.25	—	—	—	—
17	295.25	PAL	-1.25	—	—	—	—
18	303.25	PAL	-1.25	—	—	—	—
19	311.25	PAL	-1.25	—	—	—	—
20	319.25	PAL	-1.25	—	—	—	—
21	327.25	PAL	-1.25	—	—	—	—
22	335.25	PAL	-1.25	—	—	—	—
23	343.25	PAL	-1.25	—	—	—	—
24	351.25	PAL	-1.25	—	—	—	—
25	359.25	PAL	-1.25	—	—	—	—
26	367.25	PAL	-1.25	—	—	—	—
27	375.25	PAL	-1.25	—	—	—	—
28	383.25	PAL	-1.25	—	—	—	—
29	391.25	PAL	-1.25	—	—	—	—
30	399.25	PAL	-1.25	—	—	—	—
31	407.25	PAL	-1.25	—	—	—	—
32	415.25	PAL	-1.25	—	—	—	—
33	423.25	PAL	-1.25	—	—	—	—
34	431.25	PAL	-1.25	—	—	—	—
35	439.25	PAL	-1.25	—	—	—	—
36	447.25	PAL	-1.25	—	—	—	—
37	455.25	PAL	-1.25	—	—	—	—
38	463.25	PAL	-1.25	—	—	—	—
121	471.25	PAL	-1.25	—	—	—	—
122	479.25	PAL	-1.25	—	—	—	—
123	487.25	PAL	-1.25	—	—	—	—
124	495.25	PAL	-1.25	—	—	—	—
125	503.25	PAL	-1.25	—	—	—	—
126	511.25	PAL	-1.25	—	—	—	—
127	519.25	PAL	-1.25	—	—	—	—
128	527.25	PAL	-1.25	—	—	—	—
129	535.25	PAL	-1.25	—	—	—	—
130	543.25	PAL	-1.25	—	—	—	—

Table A-8: Europe-DK channels (Cont.)

Channel Number	Frequency (MHz)	Channel Type	Channel Edge (MHz)	Skip Y/N	Scrambled Y/N	Dwell Time	Amplitude Offset
131	551.25	PAL	-1.25	---	---	---	---
132	559.25	PAL	-1.25	---	---	---	---
133	567.25	PAL	-1.25	---	---	---	---
134	575.25	PAL	-1.25	---	---	---	---
135	583.25	PAL	-1.25	---	---	---	---
136	591.25	PAL	-1.25	---	---	---	---
137	599.25	PAL	-1.25	---	---	---	---
138	607.25	PAL	-1.25	---	---	---	---
139	615.25	PAL	-1.25	---	---	---	---
140	623.25	PAL	-1.25	---	---	---	---
141	631.25	PAL	-1.25	---	---	---	---
142	639.25	PAL	-1.25	---	---	---	---
143	647.25	PAL	-1.25	---	---	---	---
144	655.25	PAL	-1.25	---	---	---	---
145	663.25	PAL	-1.25	---	---	---	---
146	671.25	PAL	-1.25	---	---	---	---
147	679.25	PAL	-1.25	---	---	---	---
148	687.25	PAL	-1.25	---	---	---	---
149	695.25	PAL	-1.25	---	---	---	---
150	703.25	PAL	-1.25	---	---	---	---
151	711.25	PAL	-1.25	---	---	---	---
152	719.25	PAL	-1.25	---	---	---	---
153	727.25	PAL	-1.25	---	---	---	---
154	735.25	PAL	-1.25	---	---	---	---
155	743.25	PAL	-1.25	---	---	---	---
156	751.25	PAL	-1.25	---	---	---	---
157	759.25	PAL	-1.25	---	---	---	---
158	767.25	PAL	-1.25	---	---	---	---
159	775.25	PAL	-1.25	---	---	---	---
160	783.25	PAL	-1.25	---	---	---	---
161	791.25	PAL	-1.25	---	---	---	---
162	799.25	PAL	-1.25	---	---	---	---
163	807.25	PAL	-1.25	---	---	---	---
164	815.25	PAL	-1.25	---	---	---	---

Appendix A: Channel Tables

Table A-8: Europe-DK channels (Cont.)

Channel Number	Frequency (MHz)	Channel Type	Channel Edge (MHz)	Skip Y/N	Scrambled Y/N	Dwell Time	Amplitude Offset
165	823.25	PAL	-1.25	—	—	—	—
166	831.25	PAL	-1.25	—	—	—	—
167	839.25	PAL	-1.25	—	—	—	—
168	847.25	PAL	-1.25	—	—	—	—
169	855.25	PAL	-1.25	—	—	—	—

Europe-I Channels

Editable Fields – Defaults

Amplitude Offset: 0.0 dB Scrambled: No Dwell Time: Short Skip: No

Fixed Fields

Aural Offset: 6.0 MHz Second Aural Offset: None C/N Bandwidth: 5.5 MHz

Table A-9: Europe-I channels

Channel Number	Frequency (MHz)	Channel Type	Channel Edge (MHz)	Skip Y/N	Scrambled Y/N	Dwell Time	Amplitude Offset
21	471.25	PAL	-1.25	_____	_____	_____	_____
22	479.25	PAL	-1.25	_____	_____	_____	_____
23	487.25	PAL	-1.25	_____	_____	_____	_____
24	495.25	PAL	-1.25	_____	_____	_____	_____
25	503.25	PAL	-1.25	_____	_____	_____	_____
26	511.25	PAL	-1.25	_____	_____	_____	_____
27	519.25	PAL	-1.25	_____	_____	_____	_____
28	527.25	PAL	-1.25	_____	_____	_____	_____
29	535.25	PAL	-1.25	_____	_____	_____	_____
30	543.25	PAL	-1.25	_____	_____	_____	_____
31	551.25	PAL	-1.25	_____	_____	_____	_____
32	559.25	PAL	-1.25	_____	_____	_____	_____
33	567.25	PAL	-1.25	_____	_____	_____	_____
34	575.25	PAL	-1.25	_____	_____	_____	_____
35	583.25	PAL	-1.25	_____	_____	_____	_____
36	591.25	PAL	-1.25	_____	_____	_____	_____
37	599.25	PAL	-1.25	_____	_____	_____	_____
38	607.25	PAL	-1.25	_____	_____	_____	_____
39	615.25	PAL	-1.25	_____	_____	_____	_____
40	623.25	PAL	-1.25	_____	_____	_____	_____
41	631.25	PAL	-1.25	_____	_____	_____	_____
42	639.25	PAL	-1.25	_____	_____	_____	_____
43	647.25	PAL	-1.25	_____	_____	_____	_____
44	655.25	PAL	-1.25	_____	_____	_____	_____
45	663.25	PAL	-1.25	_____	_____	_____	_____
46	671.25	PAL	-1.25	_____	_____	_____	_____

Appendix A: Channel Tables

Table A-9: Europe-I channels (Cont.)

Channel Number	Frequency (MHz)	Channel Type	Channel Edge (MHz)	Skip Y/N	Scrambled Y/N	Dwell Time	Amplitude Offset
47	679.25	PAL	-1.25	—	—	—	—
48	687.25	PAL	-1.25	—	—	—	—
49	695.25	PAL	-1.25	—	—	—	—
50	703.25	PAL	-1.25	—	—	—	—
51	711.25	PAL	-1.25	—	—	—	—
52	719.25	PAL	-1.25	—	—	—	—
53	727.25	PAL	-1.25	—	—	—	—
54	735.25	PAL	-1.25	—	—	—	—
55	743.25	PAL	-1.25	—	—	—	—
56	751.25	PAL	-1.25	—	—	—	—
57	759.25	PAL	-1.25	—	—	—	—
58	767.25	PAL	-1.25	—	—	—	—
59	775.25	PAL	-1.25	—	—	—	—
60	783.25	PAL	-1.25	—	—	—	—
61	791.25	PAL	-1.25	—	—	—	—
62	799.25	PAL	-1.25	—	—	—	—
63	807.25	PAL	-1.25	—	—	—	—
64	815.25	PAL	-1.25	—	—	—	—
65	823.25	PAL	-1.25	—	—	—	—
66	831.25	PAL	-1.25	—	—	—	—
67	839.25	PAL	-1.25	—	—	—	—
68	847.25	PAL	-1.25	—	—	—	—

France-L Channels

Editable Fields – DefaultsSkip: No Scrambled: No Dwell Time: Short if DIGITAL Amplitude Offset: 0.0 dB
Dwell Time: Long if SECAM**Fixed Fields**Aural Offset: 6.5 MHz Second Aural Offset: None C/N Bandwidth: 6.0 MHz

Table A-10: France-L channels

Channel Number	Frequency (MHz)	Channel Type	Channel Edge (MHz)	Skip Y/N	Scrambled Y/N	Dwell Time	Amplitude Offset
120	120.00	SECAM	-1.25				
128	128.00	SECAM	-1.25				
136	136.00	SECAM	-1.25				
144	144.00	SECAM	-1.25				
160	160.00	SECAM	-1.25				
168	168.00	SECAM	-1.25				
5	176.00	SECAM	-1.25				
6	184.00	SECAM	-1.25				
7	192.00	SECAM	-1.25				
8	200.00	SECAM	-1.25				
9	208.00	SECAM	-1.25				
10	216.00	SECAM	-1.25				
224	224.00	SECAM	-1.25				
232	232.00	SECAM	-1.25				
240	240.00	SECAM	-1.25				
248	248.00	DIGITAL	-1.25				
256	256.00	DIGITAL	-1.25				
264	264.00	DIGITAL	-1.25				
272	272.00	DIGITAL	-1.25				
280	280.00	DIGITAL	-1.25				
288	288.00	DIGITAL	-1.25				
303	303.00	DIGITAL	-1.25				
315	315.00	DIGITAL	-1.25				
327	327.00	DIGITAL	-1.25				
339	339.00	SECAM	-1.25				
351	351.00	SECAM	-1.25				

Appendix A: Channel Tables

Table A-10: France-L channels (Cont.)

Channel Number	Frequency (MHz)	Channel Type	Channel Edge (MHz)	Skip Y/N	Scrambled Y/N	Dwell Time	Amplitude Offset
363	363.00	SECAM	-1.25	—	—	—	—
375	375.00	SECAM	-1.25	—	—	—	—
387	387.00	SECAM	-1.25	—	—	—	—
399	399.00	SECAM	-1.25	—	—	—	—
420	420.00	SECAM	-1.25	—	—	—	—
21	471.25	SECAM	-1.25	—	—	—	—
22	479.25	SECAM	-1.25	—	—	—	—
23	487.25	SECAM	-1.25	—	—	—	—
24	495.25	SECAM	-1.25	—	—	—	—
25	503.25	SECAM	-1.25	—	—	—	—
26	511.25	SECAM	-1.25	—	—	—	—
27	519.25	SECAM	-1.25	—	—	—	—
28	527.25	SECAM	-1.25	—	—	—	—
29	535.25	SECAM	-1.25	—	—	—	—
30	543.25	SECAM	-1.25	—	—	—	—
31	551.25	SECAM	-1.25	—	—	—	—
32	559.25	SECAM	-1.25	—	—	—	—
33	567.25	SECAM	-1.25	—	—	—	—
34	575.25	SECAM	-1.25	—	—	—	—
35	583.25	SECAM	-1.25	—	—	—	—
36	591.25	SECAM	-1.25	—	—	—	—
37	599.25	SECAM	-1.25	—	—	—	—
38	607.25	SECAM	-1.25	—	—	—	—
39	615.25	SECAM	-1.25	—	—	—	—
40	623.25	SECAM	-1.25	—	—	—	—
41	631.25	SECAM	-1.25	—	—	—	—
42	639.25	SECAM	-1.25	—	—	—	—
43	647.25	SECAM	-1.25	—	—	—	—
44	655.25	SECAM	-1.25	—	—	—	—
45	663.25	SECAM	-1.25	—	—	—	—
46	671.25	SECAM	-1.25	—	—	—	—
47	679.25	SECAM	-1.25	—	—	—	—
48	687.25	SECAM	-1.25	—	—	—	—
49	695.25	SECAM	-1.25	—	—	—	—

Table A-10: France-L channels (Cont.)

Channel Number	Frequency (MHz)	Channel Type	Channel Edge (MHz)	Skip Y/N	Scrambled Y/N	Dwell Time	Amplitude Offset
50	703.25	SECAM	-1.25				
51	711.25	SECAM	-1.25				
52	719.25	SECAM	-1.25				
53	727.25	SECAM	-1.25				
54	735.25	SECAM	-1.25				
55	743.25	SECAM	-1.25				
56	751.25	SECAM	-1.25				
57	759.25	SECAM	-1.25				
58	767.25	SECAM	-1.25				
59	775.25	SECAM	-1.25				
60	783.25	SECAM	-1.25				
61	791.25	SECAM	-1.25				
62	799.25	SECAM	-1.25				
63	807.25	SECAM	-1.25				
64	815.25	SECAM	-1.25				
65	823.25	SECAM	-1.25				
66	831.25	SECAM	-1.25				
67	839.25	SECAM	-1.25				
68	847.25	SECAM	-1.25				
69	855.25	SECAM	-1.25				

Japan-M Channels

Editable Fields – Defaults

Amplitude Offset: 0.0 dB Scrambled: No Dwell Time: Short Skip: No

Fixed Fields

Aural Offset: 6.5 MHz Second Aural Offset: None C/N Bandwidth: 6.0 MHz

Table A-11: Japan-M channels

Channel Number	Frequency (MHz)	Channel Type	Channel Edge (MHz)	Skip Y/N	Scrambled Y/N	Dwell Time	Amplitude Offset
1	91.25	NTSC	-1.25	_____	_____	_____	_____
2	97.25	NTSC	-1.25	_____	_____	_____	_____
3	103.25	NTSC	-1.25	_____	_____	_____	_____
4	171.25	NTSC	-1.25	_____	_____	_____	_____
5	177.25	NTSC	-1.25	_____	_____	_____	_____
6	183.25	NTSC	-1.25	_____	_____	_____	_____
7	189.25	NTSC	-1.25	_____	_____	_____	_____
8	193.25	NTSC	-1.25	_____	_____	_____	_____
9	199.25	NTSC	-1.25	_____	_____	_____	_____
10	205.25	NTSC	-1.25	_____	_____	_____	_____
11	211.25	NTSC	-1.25	_____	_____	_____	_____
12	217.25	NTSC	-1.25	_____	_____	_____	_____
13	471.25	NTSC	-1.25	_____	_____	_____	_____
14	477.25	NTSC	-1.25	_____	_____	_____	_____
15	483.25	NTSC	-1.25	_____	_____	_____	_____
16	489.25	NTSC	-1.25	_____	_____	_____	_____
17	495.25	NTSC	-1.25	_____	_____	_____	_____
18	501.25	NTSC	-1.25	_____	_____	_____	_____
19	507.25	NTSC	-1.25	_____	_____	_____	_____
20	513.25	NTSC	-1.25	_____	_____	_____	_____
21	519.25	NTSC	-1.25	_____	_____	_____	_____
22	525.25	NTSC	-1.25	_____	_____	_____	_____
23	531.25	NTSC	-1.25	_____	_____	_____	_____
24	537.25	NTSC	-1.25	_____	_____	_____	_____
25	543.25	NTSC	-1.25	_____	_____	_____	_____
26	549.25	NTSC	-1.25	_____	_____	_____	_____
27	555.25	NTSC	-1.25	_____	_____	_____	_____

Table A-11: Japan-M channels (Cont.)

Channel Number	Frequency (MHz)	Channel Type	Channel Edge (MHz)	Skip Y/N	Scrambled Y/N	Dwell Time	Amplitude Offset
28	561.25	NTSC	-1.25	—	—	—	—
29	567.25	NTSC	-1.25	—	—	—	—
30	573.25	NTSC	-1.25	—	—	—	—
31	579.25	NTSC	-1.25	—	—	—	—
32	585.25	NTSC	-1.25	—	—	—	—
33	591.25	NTSC	-1.25	—	—	—	—
34	597.25	NTSC	-1.25	—	—	—	—
35	603.25	NTSC	-1.25	—	—	—	—
36	609.25	NTSC	-1.25	—	—	—	—
37	615.25	NTSC	-1.25	—	—	—	—
38	621.25	NTSC	-1.25	—	—	—	—
39	627.25	NTSC	-1.25	—	—	—	—
40	633.25	NTSC	-1.25	—	—	—	—
41	639.25	NTSC	-1.25	—	—	—	—
42	645.25	NTSC	-1.25	—	—	—	—
43	651.25	NTSC	-1.25	—	—	—	—
44	657.25	NTSC	-1.25	—	—	—	—
45	663.25	NTSC	-1.25	—	—	—	—
46	669.25	NTSC	-1.25	—	—	—	—
47	675.25	NTSC	-1.25	—	—	—	—
48	681.25	NTSC	-1.25	—	—	—	—
49	687.25	NTSC	-1.25	—	—	—	—
50	693.25	NTSC	-1.25	—	—	—	—
51	699.25	NTSC	-1.25	—	—	—	—
52	705.25	NTSC	-1.25	—	—	—	—
53	711.25	NTSC	-1.25	—	—	—	—
54	717.25	NTSC	-1.25	—	—	—	—
55	723.25	NTSC	-1.25	—	—	—	—
56	729.25	NTSC	-1.25	—	—	—	—
57	735.25	NTSC	-1.25	—	—	—	—
58	741.25	NTSC	-1.25	—	—	—	—
59	747.25	NTSC	-1.25	—	—	—	—
60	753.25	NTSC	-1.25	—	—	—	—

Appendix A: Channel Tables

Table A-11: Japan-M channels (Cont.)

Channel Number	Frequency (MHz)	Channel Type	Channel Edge (MHz)	Skip Y/N	Scrambled Y/N	Dwell Time	Amplitude Offset
61	759.25	NTSC	-1.25	---	---	---	---
62	765.25	NTSC	-1.25	---	---	---	---

Table A-12: Custom Channel worksheet (Cont.)

Channel Number	Frequency (MHz)	Channel Type	Channel Edge (MHz)	Skip Y/N	Scrambled Y/N	Dwell Time	Amplitude Offset

Appendix A: Channel Tables

Appendix B: Remote Communications

The SignalScout RFM151 Cable TV RF Analyzer has an RS-232 driver, which provides a serial binary data interchange, using a 9-pin D-type connector. The connector is configured to use a standard AT-compatible PC interconnecting cable, which is included as a standard accessory with the SignalScout RF analyzer.

The SignalScout RFM151 RF analyzer can communicate with another SignalScout RF analyzer, a printer, or a computer.

Communicating with Another RFM150/1

Set up the RF analyzers to communicate with one another using the following procedure:

1. Press UTIL, then press F1 (INST CONFIG), F1 (INTERFACE CONFIG), F1 (RS232). The RS232 menu will be displayed. See Figure A-1.
2. Press any function key to select the corresponding field for edit, then turn the knob to the left or right to change the setting to match the setting of the other SignalScout RF analyzer.
3. After all fields have been edited, press ESC to exit the menu, one level at a time. The new settings will be saved.
4. Connect the supplied RS-232 cable between the source and destination instruments. Pin assignments are shown in Table A-13, and the connector location is shown in Figure A-2.

Appendix B: Remote Communications

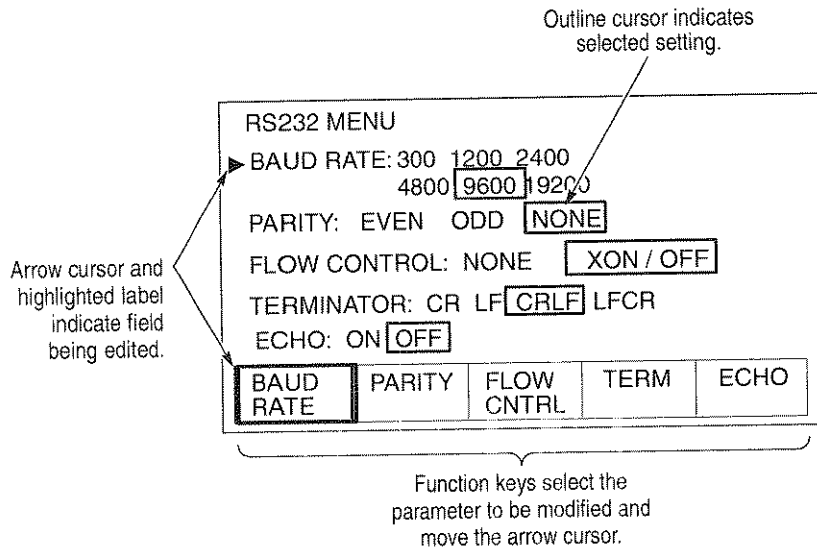

Figure A-1: RS232 menu showing factory settings

Table A-13: Pin assignments for interface port

Pin Number	Signal Name	RS-232C Name
1	Not connected	
2	RX (Receive Data)	BB
3	TX (Transmit Data)	BA
4	DTR (Data Terminal Ready)	CD
5	GND (Signal Ground)	AB
6	DSR (Data Set Ready)	CC
7	RTS (Request to Send)	CA
8	CTS (Clear to Send)	CB
9	Reserved	

5. Use the interface port as desired to import channel tables, sequences, or instrument configuration from one SignalScout RF analyzer to another SignalScout RF analyzer. Instructions appear under the following topic headings: *Channel Tables* (refer to page 3-63), *Sequences* (refer to page 3-86), and *Clone Configuration* (refer to page 3-86).

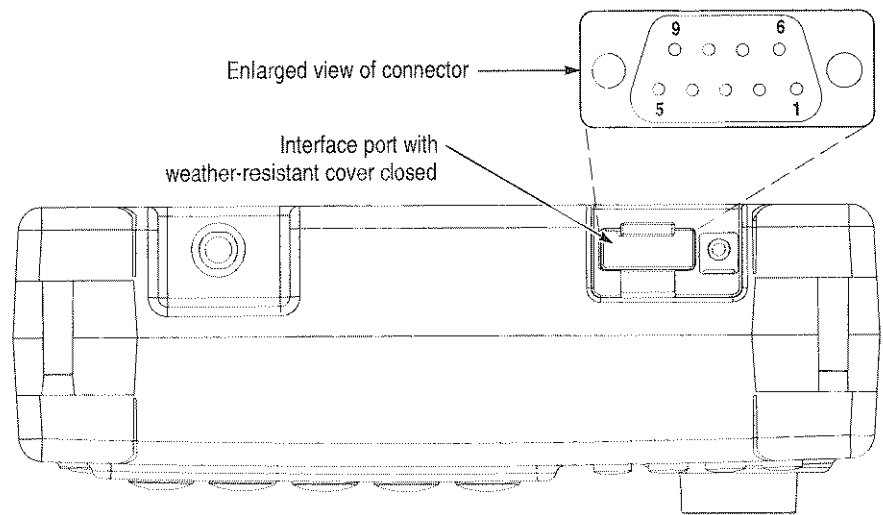

Figure A-2: Top view of SignalScout RF analyzer showing the RS-232 interface port

Communicating with a Computer (Using the SignalScout Application)

Using the companion SignalScout CSS151 software, the following applications are possible:

- Control select front-panel functions remotely
- Import channel tables or sequences from a computer
- Download measurement results to a computer for archival or use with another application, such as a spreadsheet
- Print stored measurement results and reports based on the measurement results

NOTE. *Meter, Relative Field Strength, Pilot, and 5 channel measurements are not downloaded.*

Instructions for setting up the SignalScout CSS151 software to communicate with the SignalScout RF analyzer, and instructions for downloading and uploading measurement results and channel tables are found in the *SignalScout CSS151 Software User Manual*. The next section of this appendix, *Communicating with a Printer*, provides instructions for setting up and printing stored measurement results from the SignalScout RF analyzer.

Communicating with a Printer

You can print any measurement display directly, or you can store a measurement result into the NVRAM of the SignalScout RF analyzer for print out at a later time. The SignalScout RF analyzer can send measurement results through the serial interface to a printer.

Printer Requirements

The SignalScout RF analyzer supports the following printer types:

- **TEK HC-411.** This format option can be used with any Tektronix hand-held printer and any Seiko DPU-411 printer.
- **Epson FX.** This format option can be used with any Epson compatible printer.
- **Encapsulated Postscript (EPS).** This format option works with EPS (version 1.2) compatible printers and Adobe postscript printers (version 2.0).

The printers supported by the SignalScout RF analyzer must support the following RS-232 parameters:

- SW (XON/XOFF via ^Q/^S) or HW (CTS/RTS) handshaking
- Baud rate of 300, 1200, 2400, 4800, 9600, or 19200 bits per second.
- Parity mode of even, odd, or none
- 8 data bits

Setting the Printer Parameters

Configure the SignalScout RF analyzer to communicate with a printer using the following procedure:

1. Press UTIL. Three soft key selections appear, as shown in Figure A-3.

INST CONFIG	MSMT CONFIG	CHAN TABLE		
----------------	----------------	---------------	--	--

Figure A-3: UTIL function key assignments

2. Press F1 (INST CONFIG), F1 (INTFACE CONFIG) then F2 (PRINTER). The PRINTER menu will be displayed. The factory default settings are shown in Figure A-4.

PRINTER MENU				
▶ BAUD RATE:	300	1200	2400	
	4800	9600	19200	
PARITY:	EVEN	ODD	NONE	
FLOW CONTROL:	NONE	XON / XOFF	CTS/RTS	
OUTPUT FORMAT:	TEK-DPU411	EPSON		
		POSTSCRIPT		
BAUD RATE	PARITY	FLOW CNTRL	OUTPUT FORMAT	

Figure A-4: PRINTER menu showing factory settings

3. Press any function key to select the corresponding field for edit, then turn the knob to the left or right to change the setting to match your printer.
4. After all of the fields have been edited, press ESC to exit the menu one level at a time. The new settings will be saved.

The SignalScout RF analyzer will automatically use these printer settings when a print job is active. (If no print job is active, the SignalScout RF analyzer communication mode is determined by the RS232 menu settings.)

5. Check that the parameters on your printer match those given above.

Hookup

Connect the supplied 9 pin RS-232 cable between the SignalScout RF analyzer Interface port and the printer port. If your printer has a 25-pin serial port, use a 9-pin to 25-pin adapter. Pin assignments are

shown in Table A-13 on page B-2, and the connector location is shown in Figure A-2 on page B-3.

Printing Stored Results

To print stored results, use the following procedure:

- 1.** Press STORE, then F2 (RESULTS MENU) to access the STORED RESULTS MENU.
- 2.** Use the knob to scroll through the displayed list of stored results. An outline moves from record to record as you scroll through the list and indicates which record is selected.
- 3.** Select the stored result you wish to print and press F1 (VIEW).
- 4.** When the stored result is displayed and you are ready to print, press and hold the ESC button until the instrument beeps (about three seconds).

The measurement result will be sent to the connected printer.

Appendix B: Remote Communications

Appendix C: Battery

The SignalScout RFM151 RF analyzer uses a rechargeable NiCd battery pack when operating off of DC power. This section provides procedures for replacing and recharging the battery pack.

NOTE. *Nickel-Cadmium batteries contain hazardous substances. See Battery Recycling on page xii for information on how to properly dispose of a used NiCd battery pack.*

Removing the Battery

Remove the battery pack using the following procedure (refer to Figure A-5 on page C-2.):

1. Disconnect the SignalScout RF analyzer from all AC power sources, and from all RS-232 interface and RF inputs as described in *Instrument Disassembly* on page 6-2.
2. Loosen the spring loaded screws on the rear case half of the instrument and remove the battery cover door.
3. Remove the dual-wire lead at the battery interconnect circuit board (see inset in Figure A-5) by grasping the connector and lifting straight up. Be careful not to damage the pins while removing the connector.
4. Lift the battery pack out of the SignalScout RF analyzer by grasping the plastic tab on the battery pack and pulling up until it moves freely and you can grasp the battery pack to remove it.

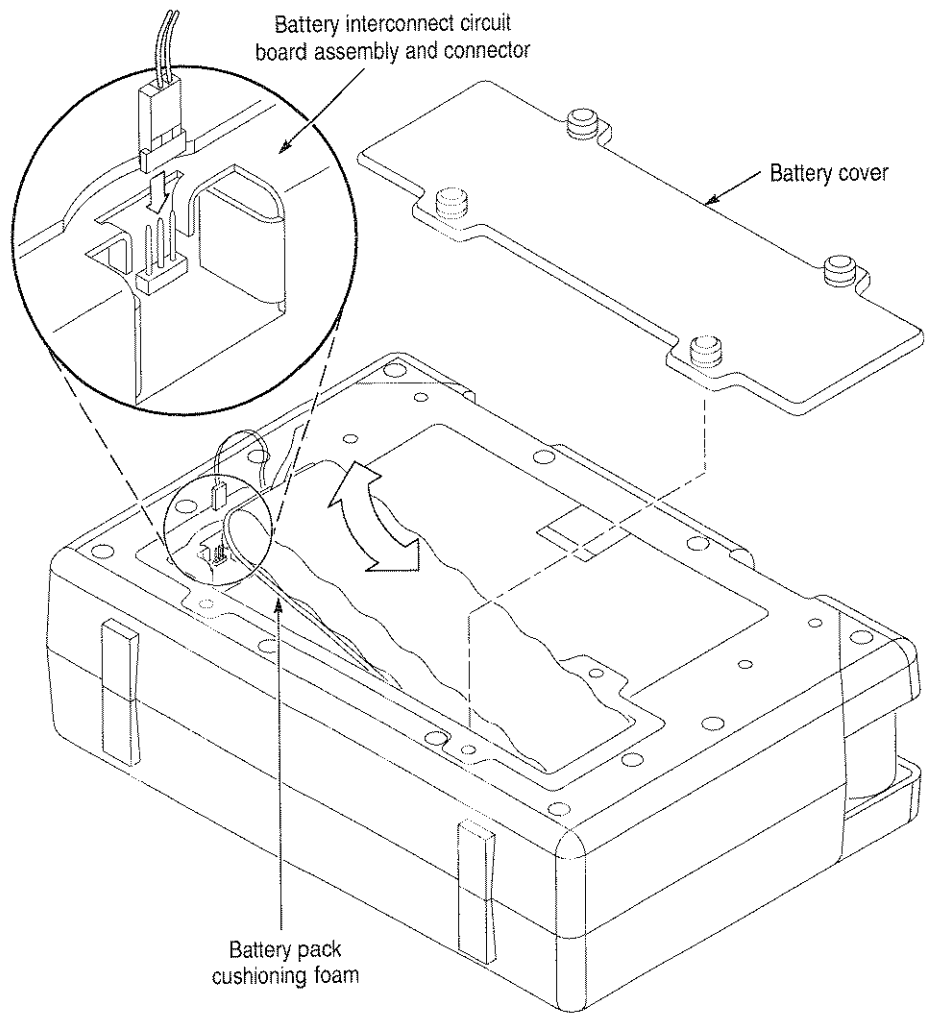

Figure A-5: Removing and replacing the NiCd battery pack

Installing the Battery

Install the battery pack using the following procedure:



CAUTION. Use only the battery recommended for use with this product.

1. Ensure that the cushioning foam is under the new battery and extends up around the battery on both ends and that the battery connector lead and connector are intact. If the lead or the connector of a new battery is damaged, return it for a replacement. Refer to the *Replaceable Mechanical Parts* list in this manual for the part number.
2. Place the new battery into the instrument with the cushioning foam down and the connector toward the interconnect board. Ensure that the battery is well seated.
3. Connect the battery lead to the 3-pin connector on the interconnect board. Ensure that the connector is fully seated and be careful not to damage the pins on the interconnect board.



CAUTION. A damaged battery lead can cause serious equipment damage.



CAUTION. To ensure the integrity of the instrument, the gasket material on the back of the battery cover must be intact. If the gasket material is damaged, replace the battery cover with a new one. Refer to the *Replaceable Mechanical Parts* list in this manual for the part number.

4. Replace the battery cover by aligning the two pins on the battery cover with the small holes in the rear case of the instrument. Ensure that the battery pack lead is not caught between the cover and the case half.
5. Tighten the battery cover screws.

Recharging the Battery

You can recharge the battery pack while it is in the instrument or you can remove the battery pack while you recharge it. Ensure that the battery pack is fully discharged before recharging.

NOTE. *The battery charger and the AC adapter are for indoor use only. Also, battery charging times and performance are based on a fully discharged battery, re-charged under the conditions described in the Specifications section, page 4-8.*

External recharger. To recharge the battery pack externally with the optional battery charger, use the following procedure:

1. Disconnect the SignalScout RF analyzer from the AC power source, RF input, and RS-232 connections.
2. Remove the battery pack using the procedure described in *Removing the Battery* on page C-1.
3. Connect the IEC connector on the external battery charger to battery pack dual-wire lead.
4. Connect the charger to an appropriate AC power source. The light on the battery charger indicates that the battery pack is recharging.
5. Allow the battery pack to charge for approximately two hours, or until the light on the battery charger goes out.
6. Install the recharged battery using the procedure described in *Installing the Battery* beginning on page C-3.

7. If the operating time from a full charge seems significantly shortened, the battery pack should be replaced. Refer to the *Replaceable Mechanical Parts* list for the part number.

Internal recharger. To recharge the battery internally with the supplied AC adapter, use the following procedure:

NOTE. *To assure proper operation under all conditions, always plug the AC adapter into the SignalScout RF analyzer before connecting to the AC power source.*

1. Connect the supplied Tektronix AC adapter to the SignalScout RF analyzer power input. Connect the adapter plug to an appropriate AC power source. The instrument will emit two short beeps, and the screen will remain blank. If this does not happen, check your power source. (See Table 4–2 on page 4–7 for power source requirements).
2. With the instrument power off, allow the SignalScout RF analyzer to charge for eight hours. Note that the battery will not charge if the instrument is turned on or in the sleep mode.
3. Remove the lead from the AC adapter to the SignalScout RF analyzer
4. If the operating time from a full charge seems significantly shortened, the battery should be replaced. Refer to the *Replaceable Mechanical Parts* list in this manual for the part number.

Appendix C: Battery

Appendix D: Exterior Cleaning



CAUTION. Do not allow water to get inside any enclosed assembly or component. Do not clean any plastic materials with benzene, toluene, xylene, acetone, or similar compounds, because they may damage the plastic.

Recommended Supplies

- Soft, non-abrasive cloths for cleaning the exterior and the LCD
- Non-abrasive liquid glass cleaner for cleaning the LCD
- Solution of water and mild liquid detergent or non-abrasive liquid glass cleaner (optional)
- Small, soft brush (optional)

Cleaning Procedure

1. Clean the outside of the instrument by wiping with the soft cloth. You may use a brush to remove dust from around control buttons, knobs, and connectors. Hardened dirt may be removed with a cloth dampened in water that contains a mild detergent or non-abrasive glass cleaner. Do not use abrasive cleaners.
2. Clean the LCD display with a soft, lint-free cloth dampened in non-abrasive glass cleaner. Do not use tissue or paper products. Do not use abrasive cleaners.

Appendix D: Exterior Cleaning

Index

Numbers

- 1 channel mode, 3-3
- 24 hour test, 3-72
- 5 channel mode, 3-8
 - presets. *See* Presets

A

- Abort a keypad entry (ABORT ENTRY). 2-3, 2-10
- Abort a sequence, 3-74
- AC input connector, 2-2
- AC power pack, 1-5
- AC power source, 4-7
- Accept an entry (ACCEPT ENTRY). 2-11
- Accessories, 1-5
- Active channel table, 3-63
- Active site name, 3-88
- Active sweep reference, 3-61
- Adapter, 1-5
- Add
 - sequences, 3-86
 - site name, 3-88
- Adjusting the display, 3-71
- Alarms, ingress monitor, 3-54
- All channel mode (ALL CHAN), 3-10
 - marker readouts, 3-12
 - using markers, 3-13
- AM signal monitoring, 3-29
- Amplitude offset (AMPLITUDE OFFSET), 2-7, 3-64
- Archiving measurement results, 3-74
- Asterisk (*). 2-7
- Audio, 2-4, 3-29

- Aural carriers, 3-31
- Auto power down, 3-79
- Auto presets, 3-9, 3-82
- Automated measurement
 - sequences, 3-72, 3-86
- Average detection (AVG), 3-31

B

- Back Board circuit board assembly replacement, 6-14
- Backlight (BACKLIGHT), 3-71
- Backspace key, 2-3
 - erase a character, 2-10
- Battery installation, C-3
- Battery recharging, C-4
- Battery replacement, C-1
- Board replacement, 6-4

C

- C/N Mode, 3-15
- Calibrated board set replacement, 6-4
- Calibration (Calibrated Board Set replacement), 6-4
- Carrier-to-noise ratio, 3-15
 - setting in- or out-of-service modes, 3-17
- Carrying case, 1-5
- Center frequency, 3-40
- Center level readout (CENTER LVL), 3-60
- Center the trace (CENTER TRACE), 3-60
- Certifications and compliances, 4-9

Index

- CHAN key, 2–3
- Changing the reference level, all
 - channel mode, 3–14
- Channel number readout, 2–6
- Channel selection, 2–8
- Channel sensitive, measurements, 3–1
- Channel tables, 3–63
 - deleting, 3–67
 - editing, 3–63
 - importing, 3–68
- Circuit board replacement, 6–4
- Cleaning the instrument, 6–23
- Clock, 3–68
- Communications, 5–12
- Configuration
 - clone, 3–70
 - pilot frequencies, 3–33
 - power units, 3–94
 - probe loss, 3–85
 - reference section, 3–63
 - the clock, 3–68
- Connector locations, 2–1
- Contrast mode (CONTRAST MODE), 3–71
- Copy the configuration of another instrument (CLONE CONFIG), 3–70
- Copying channel table values (COPY TO END), 3–67
- CSS151 software, 1–5

- D**
- D/U measurement, 3–22
- Date setting (DAY OF WEEK, DAY–MONTH), 3–69
- dBmV, 3–94
- dBuV, 3–94
- Delete
 - channel tables, 3–67
 - sequences, 3–87
 - site name, 3–89
 - stored measurement results, 3–92
- Demodulation Spectrum
 - demodulation measurements, 3–48
 - measurement setup, 3–48
 - mode, 3–46
 - spectrum measurements, 3–47
- Desired to Undesired Mode, 3–21
- Detection–peak or average, 3–31
- Difference measurements, calculation, 3–7
- Digital channel
 - creating channel table for, 3–5
 - measuring average power, 3–4
- Display contrast (DISP), 3–71
- Distortion products, preamp enabled, 3–43
- Dwell time (DWELL TIME), 3–64

E

Edit sequence, procedure, 3–73

Editing

- channel tables, 3–63
- instrument parameters, 2–9
- lists, 2–9
- outlined settings, 2–11
- preset labels, 3–82
- presets, 3–81
- text strings, 2–10

Electrical specifications, 4–1

Encoder replacement, 6–9

ENTER key, 2–3

Entry mode, 2–8

Environmental characteristics, 4–10

Erase a character, 2–3, 2–10

Execute Sequence, menu description, 3–73

Executing sequences (EXEC), 3–72

Expand/Narrow, swept frequencies, 3–43

F

F keys, 2–3

FM audio, 2–4

FM deviation (FM DEV), 3–25

FM signal monitoring, 3–29

Frequency range, ingress limit, 3–52

Frequency readout, 2–6

Front panel circuit board assembly replacement, 6–9

Front-panel controls, 2–2

Function keys, 2–3, 2–7

Fundamental hum, setting, 3–28

G

General editing methods, 2–9

General Spectrum

- measurement setup, 3–45
- mode, 3–45
- noise markers, 3–45

H

Help mode (HELP), 3–75

Hour setting (HOUR), 3–68

Hum, setting fundamental frequency, 3–28

Hum mode (HUM), 3–27

I

Importing channel tables, 3–68

In service measurements, 3–2

Ingress limit, frequency range, 3–52

Ingress Spectrum Monitor

- limits setup, 3–50
- mode, 3–48
- monitor mode setup, 3–53
- stored results, 3–56

Ingress violations, store action, 3–54

Installing the battery, C–3

Instrument cleaning, 6–23

Instrument configuration, reference section, 3–63

Instrument tuning, 2–8

Interrupting a sequence, 3–74

K

Keypad, 2-3, 2-8
Keypad replacement, 6-9
Knob, 2-3, 2-8
KNOB VOL (speaker volume control), 2-4

L

LCD display, 2-3, 3-71
LCD Display module replacement, 6-12
Level/reference menu (LVL/REF), 3-60
Limits
 setting ingress limits, 3-50
 storing violations, 3-54
 types, 3-52
Local/remote operation, 2-7

M

Making a channel table active (MAKE ACTIVE), 3-61, 3-63
Marker (MKR), spectrum measurements, 3-41
Markers
 OFF, 3-14
 readouts in all channel mode, 3-12
 using in all channel mode, 3-13
Markers (MKR1, MKR2), 3-59
MAX, limit threshold, 3-52
Max hold waveform, spectrum measurements, 3-43
Maximum span, 3-40
Measurement, reference section, 3-1

Measurement sequence, procedure, 3-73
Measurement sequences, 3-72
Measurements
 analog channel, 3-4
 digital channel, 3-4
Menu keys, 2-4
Menu tree, 2-12
Meter mode, 3-29
MHz key, 2-3
MIN, limit threshold, 3-52
Minimum span, 3-40
Minute setting (MINUTE), 3-68

N

Narrow/Expand, swept frequencies, 3-43
Noise markers, spectrum measurements, 3-45
NOW, 3-74
Numeric keypad, 2-3

O

Off channel measurements, 3-1
On channel measurements, 3-1
Options, 1-5
Out of service measurements, 3-2
OVER, 3-12

P

Parts list, 7-1, 8-1
Peak detection (PEAK), 3-31
Performance check, 5-1
Pilots mode, 3-32
Pin assignments, B-2

Power, 3-77
POWER key, 2-4
Power key, 3-77
Power plug options, 1-5
Power units, 3-12, 3-94
Power up/power down mode (PWR UP/DN), 3-79
Preamplifier, 3-43
Presets, 2-8, 3-80
Press-and-hold programming, 3-82
Print
 error message, 3-84
 hookup, B-6
 interface configuration, B-5
 reference, 3-83
Printer requirements, B-5
Probe loss, 3-85
Programming the presets, 3-82

R

RBW, spectrum measurements, 3-41
Readouts, 2-6
Recharging the battery, C-4
REF LVL, 3-9
Reference information, configuration, 3-63
Reference level, 3-9, 3-12, 3-30
Reference level (REF), 3-41
Relative Field Strength
 display elements, 3-35
 illustration, 3-34
 measurements, 3-37
 mode, 3-34
 readouts, 3-36
Remote communications, 5-12
Remote connector, 2-1
Remote/local operation, 2-7
Repeat times for sequence (REPEAT TIMES), 3-73

Replacing
 the Back Board circuit board assembly, 6-14
 the encoder, 6-9
 the Front Panel circuit board assembly, 6-9
 the keypads, 6-9
 the LCD Display module, 6-12
 the speaker, 6-9
Replacing the battery, C-1
Replacing the Calibrated Board Set, 6-4
Resolution bandwidth (RBW), 3-31
Results menu (RESULTS MENU), 3-74, 3-91
RF input connector, 2-1

S

Scrambled channels (SCRAMBLED), 3-64
Select a channel (SELECT CHAN), 3-66
Select a field (SELECT FIELD), 3-67
Sequences, 3-86
 aborting, 3-72
 archiving results, 3-74
 deleting, 3-87
 interrupting, 3-72
Set the temperature (SET TEMP), 3-93
Setting fundamental hum frequency, 3-28
Site name, 3-88
Skipping channels (SKIP), 3-12, 3-64
Sleep state, 3-74, 3-77
Soft keys, 2-3
Span/div (SPAN), 3-40

Index

Speaker, 2-4, 3-29
Speaker replacement, 6-9
Specifications, 4-1
Spectrum mode (SPECT), 3-38
Start sequence (START SEQ), 3-74
Start time for sequence (START TIME), 3-73
Store, 3-88
 a sweep reference, 3-61
 measurement results, 3-90
 site name, 3-88
 temperature, 3-93
Stored information display (STORED INFO), 3-91
Storing measurement results, 1-4
Sweep delay, ingress monitor, 3-54
Sweep mode, 3-58
Sweep reference, 3-61

T

Temperature, 3-93
Temperature units (TEMP UNITS), 3-93
Test record, 5-2
Text strings, 2-3, 2-10
Time, 3-68

Tuning, 2-8
Turning markers off, all channel mode, 3-14
Two-carrier sound channels, 3-4

U

Units, 3-94

V

VERT, spectrum measurements, 3-41
View measurement result (VIEW), 3-74, 3-91
Violation action, ingress limits, 3-54
Volume, 2-4

W

Windowed sweep, 3-43

Y

Year setting (YEAR), 3-68