

User Manual

Tektronix

**PS280 & PS283
DC Power Supplies**

070-8355-03



Copyright © Tektronix, Inc. 1991. All rights reserved.

Tektronix products are covered by U.S. and foreign patents, issued and pending. Information in this publication supercedes that in all previously published material. Specifications and price change privileges reserved.

Tektronix, Inc., P.O. Box 1000, Wilsonville, OR 97070-1000

TEKTRONIX and TEK are registered trademarks of Tektronix, Inc.

WARRANTY

Tektronix warrants that this product will be free from defects in materials and workmanship for a period of one (1) year from the date of shipment. If any such product proves defective during this warranty period, Tektronix, at its option, either will repair the defective product without charge for parts and labor, or will provide a replacement in exchange for the defective product.

In order to obtain service under this warranty, Customer must notify Tektronix of the defect before the expiration of the warranty period and make suitable arrangements for the performance of service. Customer shall be responsible for packaging and shipping the defective product to the service center designated by Tektronix, with shipping charges prepaid. Tektronix shall pay for the return of the product to Customer if the shipment is to a location within the country in which the Tektronix service center is located. Customer shall be responsible for paying all shipping charges, duties, taxes, and any other charges for products returned to any other locations.

This warranty shall not apply to any defect, failure or damage caused by improper use or improper or inadequate maintenance and care. Tektronix shall not be obligated to furnish service under this warranty a) to repair damage resulting from attempts by personnel other than Tektronix representatives to install, repair or service the product; b) to repair damage resulting from improper use or connection to incompatible equipment; or c) to service a product that has been modified or integrated with other products when the effect of such modification or integration increases the time or difficulty of servicing the product.

THIS WARRANTY IS GIVEN BY TEKTRONIX WITH RESPECT TO THIS PRODUCT IN LIEU OF ANY OTHER WARRANTIES, EXPRESSED OR IMPLIED. TEKTRONIX AND ITS VENDORS DISCLAIM ANY IMPLIED WARRANTIES OF MERCHANTABILITY OR FITNESS FOR A PARTICULAR PURPOSE. TEKTRONIX' RESPONSIBILITY TO REPAIR OR REPLACE DEFECTIVE PRODUCTS IS THE SOLE AND EXCLUSIVE REMEDY PROVIDED TO THE CUSTOMER FOR BREACH OF THIS WARRANTY. TEKTRONIX AND ITS VENDORS WILL NOT BE LIABLE FOR ANY INDIRECT, SPECIAL, INCIDENTAL, OR CONSEQUENTIAL DAMAGES IRRESPECTIVE OF WHETHER TEKTRONIX OR THE VENDOR HAS ADVANCE NOTICE OF THE POSSIBILITY OF SUCH DAMAGES.



Table of Contents

- General Safety Summary** **iii**
- Getting Started** **1**
- Preparing the Power Supply for Use 2
- Front Panel 4
- Turning On the Instrument 8
- Reference** **9**
- Constant Voltage/Constant Current Crossover 9
- Setting the Current Limit 10
- Test Modes 11
- Independent Modes 11
- Tracking Modes 20
- Appendix A: Specifications** **25**
- Appendix B: Maintenance** **29**
- Cleaning 29
- Preparing for Shipment 29
- Troubleshooting 30
- Appendix C: Replaceable Parts** **33**
- Standard Accessories 33
- Optional Accessories 33

List of Figures

Figure 1: Line Voltage Selectors, Power Input, and Fuse Locations	2
Figure 2: PS280 or PS283 Front Panel	4
Figure 3: Constant Voltage/Constant Current Crossover	10
Figure 4: Independent Floating Application	12
Figure 5: Independent Common Ground-Referenced Application	14
Figure 6: Independent Ground-Referenced Split Application ..	15
Figure 7: Three Ground-Referenced Negative Power Supplies	16
Figure 8: Three Ground-Referenced Positive Power Supplies .	17
Figure 9: Independent Positive Stacked Application	18
Figure 10: Independent Negative Stacked Application	19
Figure 11: Series Tracking Inside the PS280 or PS283	20
Figure 12: Series Tracking Application	21
Figure 13: Parallel Tracking Inside the PS280 or PS283	23
Figure 14: Parallel Tracking Application	24



General Safety Summary

Review the following safety precautions to avoid injury and prevent damage to this product or any products connected to it.

Injury Precautions

Use Proper Power Cord

To avoid fire hazard, use only the power cord specified for this product.

Avoid Electric Overload

To avoid electric shock or fire hazard, do not apply a voltage to a terminal that is outside the range specified for that terminal.

Ground the Product

This product is grounded through the grounding conductor of the power cord. To avoid electric shock, the grounding conductor must be connected to earth ground. Before making connections to the input or output terminals of the product, ensure that the product is properly grounded.

Do Not Operate Without Covers

To avoid electric shock or fire hazard, do not operate this product with covers or panels removed.

Use Proper Fuse

To avoid fire hazard, use only the fuse type and rating specified for this product.

General Safety Summary

Do Not Operate in Wet/Damp Conditions

To avoid electric shock, do not operate this product in wet or damp conditions.

Do Not Operate in Explosive Atmosphere

To avoid injury or fire hazard, do not operate this product in an explosive atmosphere.

Product Damage Precautions

Use Proper Voltage Setting

Before applying power, ensure that the line selector is in the proper position for the power source being used.

Provide Proper Ventilation

To prevent product overheating, provide proper ventilation.

Do Not Operate With Suspected Failures

If you suspect there is damage to this product, have it inspected by qualified service personnel.

Safety Terms and Symbols

Terms in This Manual

These terms may appear in this manual:



WARNING. Warning statements identify conditions or practices that could result in injury or loss of life.

General Safety Summary



CAUTION. Caution statements identify conditions or practices that could result in damage to this product or other property.

Terms on the Product

These terms may appear on the product:

DANGER indicates an injury hazard immediately accessible as you read the marking.

WARNING indicates an injury hazard not immediately accessible as you read the marking.

CAUTION indicates a hazard to property including the product.

Symbols on the Product

The following symbols may appear on the product:



DANGER
High Voltage



Protective Ground
(Earth) Terminal



ATTENTION
Refer to
Manual



Double
Insulated

Certifications and Compliances

CSA Certified Power Cords

CSA Certification includes the products and power cords appropriate for use in the North America power network. All other power cords supplied are approved for the country of use.

General Safety Summary

Getting Started

The Tektronix PS280 or PS283 Laboratory DC Power Supply is a multifunction bench or portable instrument. This regulated power supply provides a fixed 5 V output for powering logic circuits and two variable outputs for a wide variety of test and experimental uses.

The PS280 or PS283 contains two identical, independently adjustable DC power supplies that you can vary from 0 to 30 V. The current on the PS280 variable power supplies varies from 0 to 2 A. The current on the PS283 variable power supplies varies from 0 to 1 A. In all other respects the instruments are identical. Unless otherwise noted, descriptions and procedures in this manual apply to both instruments.

Front panel switches select one of three modes of operation:

- Independent — In this mode, the output voltage and current of each supply can be controlled independently.
- Series — In this tracking mode, the variable outputs are connected in series, and the controls of the master power supply adjust the voltages or currents of both power supplies. Series mode allows the power supplies to be varied from 0 to 60 V at 0 to 2 A for the PS280, or 0 to 1 A for the PS283.
- Parallel — In this tracking mode, the variable outputs are connected in parallel, and the controls of the master power supply adjust the voltages or currents of both power supplies. Parallel mode allows the power supplies to be varied from 0 to 4 A for the PS280 at 0 to 30 V, or from 0 to 2 A at 0 to 30 V for the PS283.

Preparing the Power Supply for Use

Check the following items prior to operating the Laboratory DC Power Supply for the first time (see Figure 1 for locations of items 1 through 3):

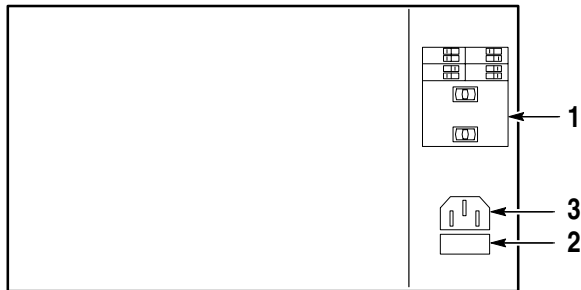

Figure 1: Line Voltage Selectors, Power Input, and Fuse Locations



CAUTION. To prevent damage to the instrument, set the line voltage selectors to the proper voltage setting and install the correct line voltage fuse before operating the equipment.

1. Set the line voltage selectors to the input line voltage. These selectors connect internal wiring for various line voltages. This product is intended to operate from a power source that does not supply more than 250 V_{RMS} between the supply conductors or between either supply conductor and ground. For line voltage ranges, refer to *Appendix A: Specifications* on page 25.



WARNING. To prevent electrical shock, unplug the power cord and disconnect the test leads from the circuit before checking or replacing the fuse.

2. Check that the correct line fuse is installed. The line fuse provides protection if the equipment malfunctions or an overload

occurs. Refer to *Appendix C: Replaceable Parts* on page 33 for fuse part numbers.



WARNING. *To prevent electrical shock, connect the power cord to a properly grounded power source. The outside (ground) of this connector is connected through the equipment to the power source ground. Do not remove the ground lug from the power cord for any reason.*

3. Connect the input power cord. Use only the power cords specified for this equipment. Refer to *Appendix C: Replaceable Parts* on page 33 for power cord part numbers.

Front Panel

Figure 2 shows the front-panel controls, connectors, and indicators with brief descriptions following the figure.

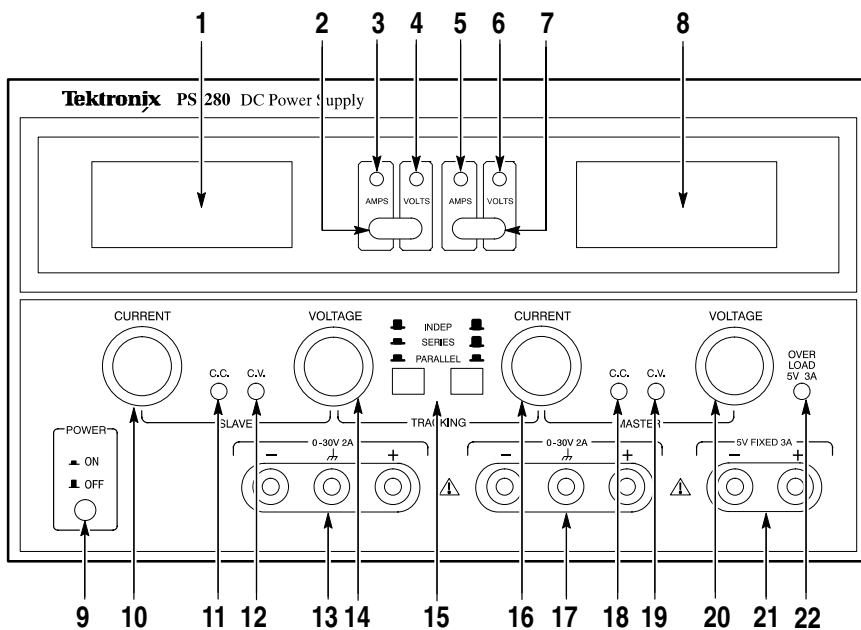

Figure 2: PS280 or PS283 Front Panel

1. LED Display. Lights when the instrument is turned on. The numbers indicate the voltage or current produced by the left variable power supply.
2. AMPS/VOLTS Switch. This switch selects whether the LED display for the left variable power supply shows the current or the voltage. If the switch is pushed to the left, the display shows the current. If the switch is pushed to the right, the display shows the voltage.

3. **AMPS Indicator.** Lights when AMPS is selected with the AMPS/VOLTS switch for the left variable power supply.
4. **VOLTS Indicator.** Lights when VOLTS is selected with AMPS/VOLTS switch for the left variable power supply.
5. **AMPS Indicator.** Lights when AMPS is selected with the AMPS/VOLTS switch for the right variable power supply.
6. **VOLTS Indicator.** Lights when VOLTS is selected with AMPS/VOLTS switch for the right variable power supply.
7. **AMPS/VOLTS Switch.** This switch selects whether the LED display for the right variable power supply shows the current or the voltage. If the switch is pushed to the left, the display shows the current. If the switch is pushed to the right, the display shows the voltage.
8. **LED Display.** Lights when the instrument is turned on. The numbers indicate the voltage or current produced by the right variable power supply.
9. **POWER Button.** Turns on the instrument when pressed. When pressed again, it turns off the instrument.
10. **CURRENT Knob.** Use this control to set the output current for the right, variable power supply. If the instrument is in a tracking mode, the left power supply is the slave and the CURRENT knob has no effect.
11. **C.C. Indicator.** If this is lighted, the left variable power supply is producing a constant current. See Figure 3 on page 10 for an illustration of the constant voltage/constant current cross-over point.
12. **C.V. Indicator.** If this is lighted, the left variable power supply is producing a constant voltage. See Figure 3 on page 10 for an illustration of the constant voltage/constant current cross-over point.

- 13. Output Terminals.** These terminals for the left, variable power supply allow you to plug in the test leads as follows:
- The red terminal on the right is the positive polarity output terminal. It is indicated by a + sign above it.
 - The black terminal on the left is the negative polarity output terminal. It is indicated by a – sign above it.
 - The green terminal in the middle is the earth and chassis ground.
- 14. VOLTAGE Knob.** Allows you to set the output voltage for the left variable power supply. If the instrument is in a tracking mode, the left power supply is the slave and the VOLTAGE knob has no effect.
- 15. TRACKING Buttons.** These buttons select the test mode of the instrument. The PS280 or PS283 features two tracking modes: series and parallel. If both push-button switches are disengaged (out), the two variable power supplies operate independently. If the left switch is pushed in, the instrument operates in series mode. If both switches are pushed in, the instrument operates in parallel mode.
- In series mode, the master power supply controls the voltage for both power supplies, which can then range from 0 to 60 V. Refer to *Series* on page 20 for further details.
- In parallel mode, the master power supply controls both the voltage and the current for both power supplies. The current can then range from 0 to 4 A (0 to 2 A for the PS283). Refer to *Parallel* on page 22 for further details.
- 16. CURRENT Knob.** Use this control to set the output current for the right, variable power supply. If the instrument is in a tracking mode, the right power supply is the master and the CURRENT knob affects both variable power supplies.

17. **Output Terminals.** These terminals for the right, variable power supply allow you to plug in the test leads as follows:
 - The red terminal on the right is the positive polarity output terminal. It is indicated by a plus (+) sign above it.
 - The black terminal on the left is the negative polarity output terminal. It is indicated by a minus (–) sign above it.
 - The green terminal in the middle is the earth and chassis ground.
18. **C.C. Indicator.** If this is lighted, the power supply is producing a constant current. See Figure 3 on page 10 for an illustration of the constant voltage/constant current crossover point.
19. **C.V. Indicator.** If this is lighted, the power supply is producing a constant voltage. See Figure 3 on page 10 for an illustration of the constant voltage/constant current crossover point.
20. **VOLTAGE Knob.** Allows you to set the output voltage for the right variable power supply. If the instrument is in a tracking mode, the right power supply is the master and the VOLTAGE knob affects both variable power supplies.
21. **Output Terminals.** These terminals for the 5 V FIXED power supply allow you to plug in the test leads as follows:
 - The red terminal on the right is the positive polarity output terminal.
 - The black terminal on the left is the negative polarity output terminal.
22. The overload indicator lights when the current on the 5 V FIXED power supply becomes too large.

Turning On the Instrument

After you have ensured that the PS280 or PS283 is set up for the proper line voltage and has the proper fuse (refer to *Preparing the Power Supply for Use* on page 2), you are ready to turn it on.



CAUTION. *To avoid damaging the PS280 or PS283, do not use it when the ambient air temperature exceeds 40° C. Also, allow adequate space at the rear of the instrument to permit the heat sink to radiate heat.*

1. Ensure that the **POWER** button is disengaged (out) and that the instrument is turned off.
2. Plug the power cord into an appropriate power source.
3. Turn both **VOLTAGE** knobs counterclockwise to the minimum setting.
4. Press the **POWER** button. The LED displays light up.

Reference

This section tells how to set the PS280 or PS283 current limit. It also explains the constant voltage/constant current crossover characteristic of the instrument. Finally, the section includes procedures for using the instrument in both independent and tracking modes and provides examples of a variety of applications.

Constant Voltage/Constant Current Crossover

The PS280 or PS283 DC Power Supply features a constant voltage/constant current automatic crossover. This feature permits continuous operation in the transition from constant-voltage mode to constant-current mode as the load changes. The intersection of the constant-current and constant-voltage modes is called the crossover point. Figure 3 on page 10 shows the relationship between the load and the crossover point.

For example, if the load is such that the power supply is operating in constant-voltage mode, the PS280 or PS283 provides a regulated output voltage. The output voltage remains constant as the load increases until the preset current limit is reached. Then the crossover occurs. At that point, the output current becomes constant and the output voltage drops in proportion to further load increases.

Crossover is indicated by the front panel red C.C. and green C.V. indicator lights. If the C.V. indicator is lighted, the instrument is operating in constant-voltage mode. If the C.C. indicator is lighted, the instrument is operating in constant-current mode.

Crossover from the constant-current mode to the constant-voltage mode also occurs automatically in response to a decrease in load. For example, suppose you are charging a 12 V battery. Initially, the open circuit voltage of the power supply is preset for 13.8 V. A low battery places a heavy load on the power supply, and it operates in constant-current mode. You adjust the instrument to charge the battery at the rate of 1 A. As the battery becomes charged and its voltage approaches 13.8 V, the load decreases to the point where the battery no longer demands the full 1 A charging rate. The PS280 or PS283 then crosses over to constant-voltage mode.

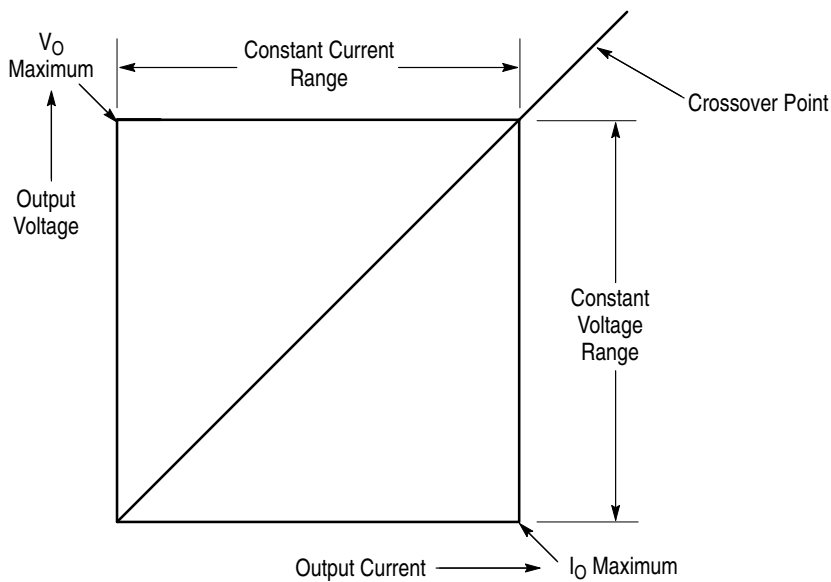

Figure 3: Constant Voltage/Constant Current Crossover

Setting the Current Limit

Before you begin using the PS280 or PS283 to power a device, you should set its current limit lower than the maximum safe current for the device to be powered.



CAUTION. In order to avoid damaging your device with a current overload, set the current limit on the PS280 or PS283 before you connect it to your device.

1. Determine the maximum safe current for the device to be powered.
2. With the test lead, temporarily short the positive and the negative output terminals of the power supply together.

3. Rotate the **VOLTAGE** knob away from zero sufficiently to light the **C.C.** indicator.
4. Set the meter selection switch to **AMPS** so that the LED display shows the current.
5. Adjust the **CURRENT** knob for the desired current limit.
6. Read the value shown on the LED display. This is your preset current limit. Do not increase the current control setting.
7. Remove the short between the positive and negative output terminals.

You are now ready to power your device.

Test Modes

The two variable power supplies on your PS280 or PS283 can be operated independently of each other, or the slave supply can track the master supply. Below are instructions for operating the instrument in independent modes, followed by instructions for operating the instrument in series or parallel tracking modes.

Independent Modes

In independent mode, any one output of each power supply can be connected to any one terminal of another supply or to ground. The variable supplies are independently controlled by the front panel **VOLTAGE** and **CURRENT** control knobs.

There are three independent modes in which you can operate the PS280 or PS283: floating, ground-referenced, and stacked.

In floating mode, the power supply is not referenced with respect to ground.

In ground-referenced mode, one of the output terminals is grounded, providing a fixed reference point for your measurement.

In stacked mode, you connect the negative output terminal of one variable power supply to the positive output terminal of the other. The stacked configuration allows you to test a circuit requiring between 30 and 60 V. A stacked configuration can be either floating or ground-referenced.

Floating. In the independently floating mode, each variable power supply provides from 0 to 30 V at 0 to 2 A (0 to 1 A for the PS283).

Figure 4 shows each of the three power supplies connected to a separate load.

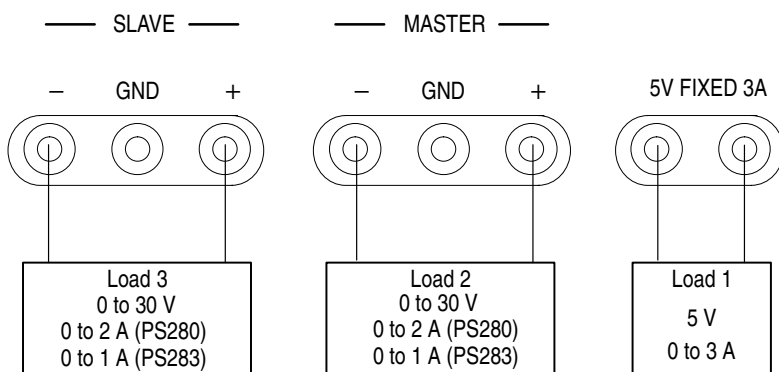

Figure 4: Independent Floating Application

The tracking switches are disengaged for independent operation. The left voltage and current control knobs control the outputs for the slave variable power supply, and the right knobs do the same for the master power supply. All outputs are electrically independent.

To test a circuit in the independently floating mode, follow these steps:

1. Press the **POWER** button to apply power to the PS280 or PS283.
2. Rotate the **VOLTAGE** knob to zero.
3. Determine the polarity of your device.

4. Plug one of the test leads into the positive output terminal.
5. Plug the other test lead into the negative output terminal.
6. Press **POWER** to turn off the PS280 or PS283.
7. Clip the positive test lead to the positive pole of your device.
8. Clip the negative test lead to the negative pole of your device.
9. Press **POWER** to turn on the PS280 or PS283.
10. Push the **AMPS/VOLTS** selection switch so that the LED display shows either voltage or current, as you want.
11. Rotate the **VOLTAGE** knob as desired.
12. If you are using a preset current limit (see page 10), do not touch the **CURRENT** knobs. Otherwise, rotate the **CURRENT** knob as desired.

Ground-Referenced. In the independently ground-referenced mode, each variable power supply provides from 0 to 30 V referenced with respect to ground at 0 to 2 A (0 to 1 A for the PS283). Any one of a pair of output terminals, either the positive or the negative, can be connected to ground. The FIXED 5 V power supply can also be ground-referenced.



WARNING. *In order to avoid grounding the power line, which can cause electrical shock, explosion, or fire, isolate the device being powered from the line voltage power source when using any ground-referenced output configuration from the PS280 or PS283.*

Figure 5 shows an example of a circuit with the FIXED 5 V terminal referenced to ground and both the master and slave variable power supplies referenced to -5 V.

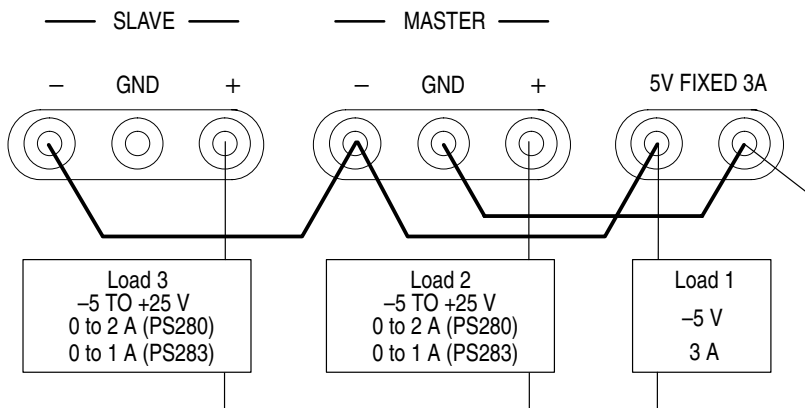

Figure 5: Independent Common Ground-Referenced Application

In this configuration, each of the variable power supplies can be varied from -5 V to $+25\text{ V}$ ($+30\text{ V}$ overall). The GND post becomes the relative negative terminal for both variable outputs. Because the variable power supplies are referenced to -5 V , the LED display, when set to display volts, shows a value that is five volts lower than the actual output.

For example, the LED display indicates:

- 0 V when the output is -5 V
- 5 V when the output is 0 V
- 30 V when the output is 25 V

Negative 5 V is available between GND and the negative terminal of the FIXED 5 V power supply.

To test a circuit in the independently ground-referenced mode, follow these steps:

1. Turn the **POWER** off to the PS280 or PS283.
2. Connect the outputs as shown in Figure 5.
3. Set both variable supply **VOLTAGE** controls to the minimum setting.

4. Set both variable supply **CURRENT** controls to midrange.
5. Set the **AMPS/VOLTS** switches for both power supplies to display volts.
6. Turn on the **POWER** to the PS280 or PS283. The display should read 0 V for both variable power supplies. An external meter connected across the load or load terminals should read -5 V.
7. Turn the **POWER** off to the PS280 or PS283 again.
8. Connect the device or devices to be tested.
9. Turn on the **POWER** to the PS280 or PS283 again. Adjust the voltages as needed.

Figure 6 shows the PS280 or PS283 connected to produce separate outputs of +5 V from the FIXED power supply, 0 to +30 V from the slave variable power supply, and 0 to -30 V from the master variable power supply. In this configuration, the red output terminal of the master variable power supply is the negative reference terminal because it is directly connected to the ground terminal.

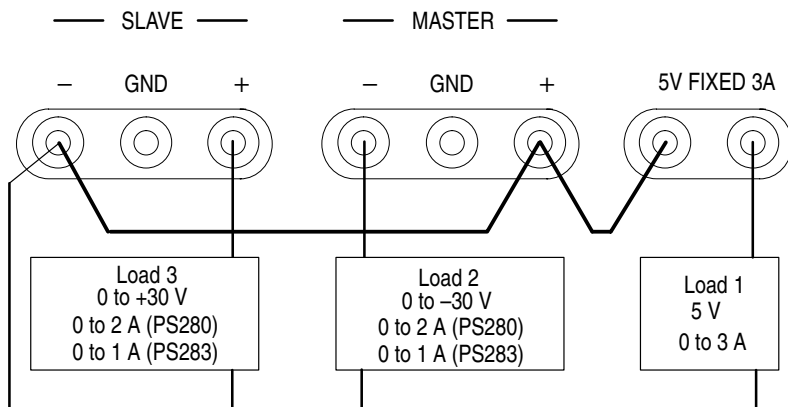

Figure 6: Independent Ground-Referenced Split Application

To test a circuit in a independent ground-referenced split application mode, follow these steps:

1. Turn the **POWER** off to the PS280 or PS283.
2. Connect the outputs as shown in Figure 6.
3. Set both variable supply **VOLTAGE** controls to the minimum setting.
4. Set both variable supply **CURRENT** controls to midrange.
5. Turn on the **POWER** to the PS280 or PS283.
6. Set the desired voltages for both variable power supplies.
7. Turn the **POWER** off to the PS280 or PS283 again.
8. Connect the device or devices to be tested.
9. Turn on the **POWER** to the PS280 or PS283 again. If necessary, readjust the voltages.

Figure 7 shows the configuration for three ground-referenced negative power supplies.

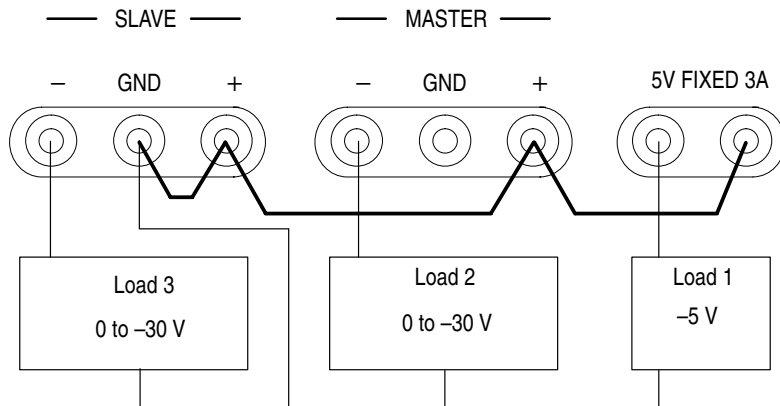

Figure 7: Three Ground-Referenced Negative Power Supplies

Figure 8 shows the configuration for three ground-referenced positive power supplies.

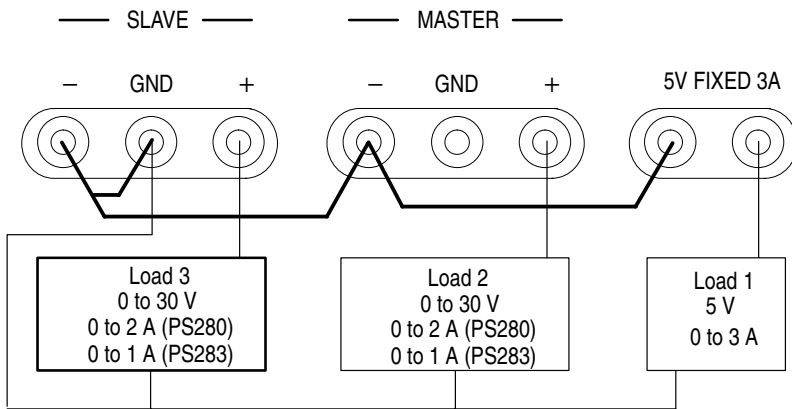

Figure 8: Three Ground-Referenced Positive Power Supplies

Stacked. In the independently stacked mode, the variable power supplies are connected and provide from 0 to 60 V at 0 to 2 A (0 to 1 A for the PS283).

Figure 9 on page 18 shows the PS280 or PS283 connected in a stacked manner to produce a variable output of 0 to +60 V ground-referenced. The FIXED power supply produces -5 V, ground-referenced. In this configuration, the red output terminal of the master variable power supply is the negative reference terminal because it is directly connected to the ground terminal.

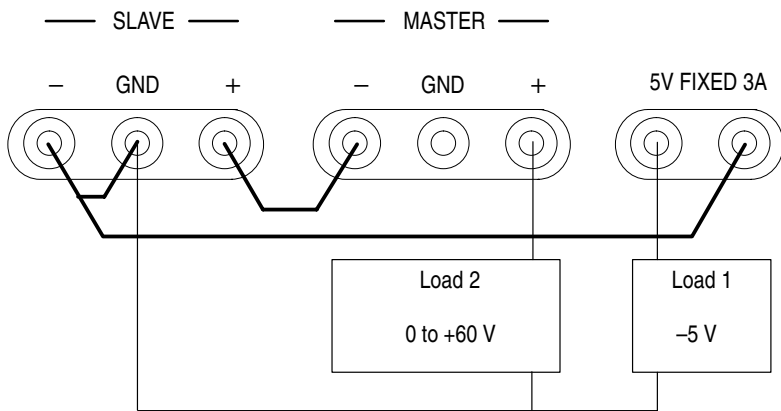

Figure 9: Independent Positive Stacked Application

To test a circuit in the independently stacked mode, follow these steps:

1. Turn the **POWER** off to the PS280 or PS283.
2. Connect the outputs as shown in Figure 9.
3. Set both variable supply **VOLTAGE** controls to the minimum setting.
4. Set both variable supply **CURRENT** controls to midrange.
5. Turn on the **POWER** to the PS280 or PS283.
6. Set the desired voltage. Observe the LED display; the total output is the sum of both voltage readings.
7. Turn the **POWER** off to the PS280 or PS283 again.
8. Connect the device or devices to be tested.
9. Turn on the **POWER** to the PS280 or PS283 again. If necessary, readjust the voltages.

Figure 10 shows a stacked application in which you have a 0 to -60 V output from the variable power supplies and a +5 V output from the FIXED power supply.

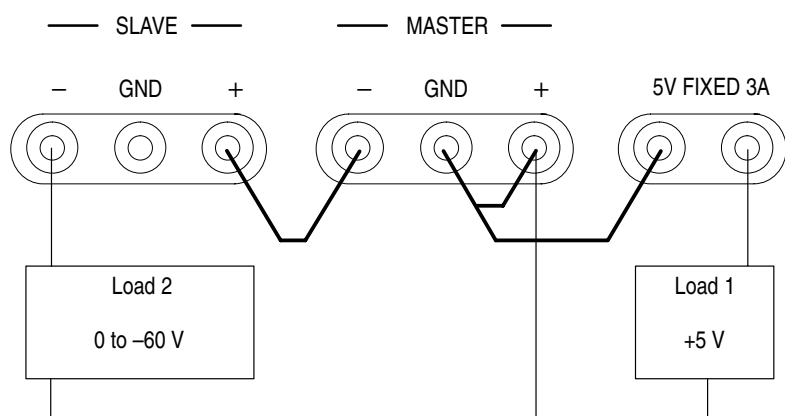

Figure 10: Independent Negative Stacked Application

Tracking Modes

There are two tracking modes in which you can operate the PS280 or PS283: series and parallel.

Series. In series mode, the positive output terminal of the master variable power supply is internally connected to the negative output terminal of the slave power supply. This connection allows the PS280 or PS283 to produce 0 to 60 V at 0 to 2 A (0 to 1 A for the PS283).

When you place the PS280 or PS283 in series mode, the output terminals are hooked together internally as shown in Figure 11.

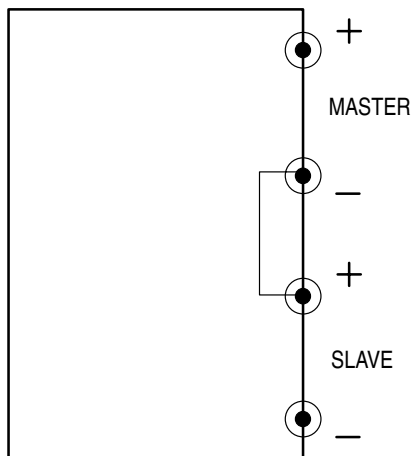

Figure 11: Series Tracking Inside the PS280 or PS283

The voltage knob for the master variable power supply controls the voltage for both variable power supplies. Using the master voltage control, the maximum slave supply voltage is automatically set to the same value as the master supply.

To test a circuit in the series tracking mode, follow these steps:

1. Turn the **POWER** off to the PS280 or PS283.
2. Connect the outputs as shown in Figure 12.

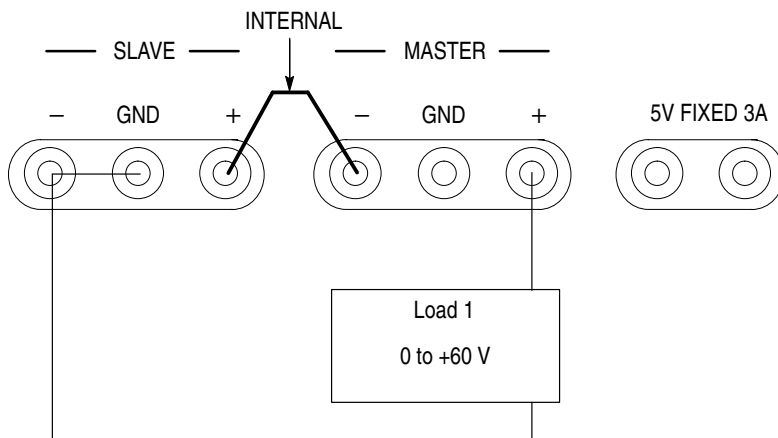

Figure 12: Series Tracking Application

3. Set the PS280 or PS283 to series tracking mode by pressing the left **TRACKING** button. Make sure that the right **TRACKING** button is released (out).
4. Set the master **AMPS/VOLTS** switch to the voltage metering position. Set the slave **AMPS/VOLTS** switch to the current metering position. This allows you to simultaneously monitor both current and voltage.

NOTE. In series tracking mode, the output voltage is double the value displayed on the voltage metering LED display, because both supplies are producing the same voltage.

5. Set the slave **CURRENT** knob fully clockwise.
6. Set the current limit using the master **CURRENT** knob. (Refer to *Setting the Current Limit* on page 10.)

NOTE. *In series tracking mode, the current flowing through the two supplies must be equal. Therefore, the maximum current limit is the lower of the values set by the two current control knobs.*

7. Turn on the **POWER** to the PS280 or PS283.
8. Adjust the output voltage to the desired level using the master **VOLTAGE** knob.
9. Turn the **POWER** off to the PS280 or PS283 again.
10. Connect the device or devices to be tested.
11. Turn on the **POWER** to the PS280 or PS283 again. Readjust the voltages if necessary.

NOTE. *The 5 V FIXED supply can be independently grounded or allowed to float.*

Parallel. In parallel tracking mode, the positive output terminals of both variable power supplies are internally connected, and the negative output terminals of both variable power supplies are internally connected. These connections allow the PS280 or PS283 to produce 0 to 30 V at 0 to 4 A (0 to 2 A for the PS283).

When you place the PS280 or PS283 in parallel mode, the output terminals are hooked together internally as shown in Figure 13.

The master power supply's **VOLTAGE** and the **CURRENT** knobs control the voltage and current for both variable power supplies.

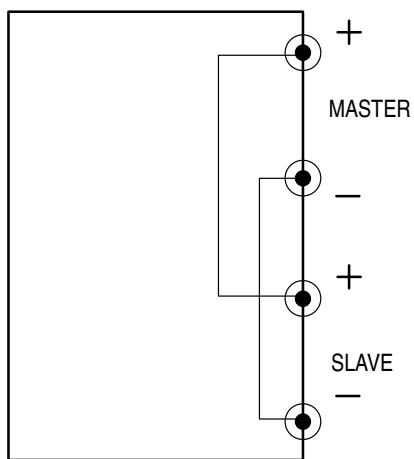

Figure 13: Parallel Tracking Inside the PS280 or PS283

To test a circuit in the parallel tracking mode, follow these steps:

1. Turn the **POWER** off to the PS280 or PS283.
2. Connect the outputs as shown in Figure 14 on page 24.
3. Set the PS280 or PS283 to parallel tracking mode by pressing both tracking buttons.
4. Set the master **AMPS/VOLTS** switch to the voltage metering position, and set the slave **AMPS/VOLTS** switch to the current metering position. This allows you to simultaneously monitor both current and voltage.

NOTE. In parallel tracking mode, the output current is double the value displayed on the current metering LED display, because both supplies are producing the same amount of current.

5. Turn on the **POWER** to the PS280 or PS283.
6. Set the current limit using the master **CURRENT** knob. (Refer to *Setting the Current Limit* on page 10.)

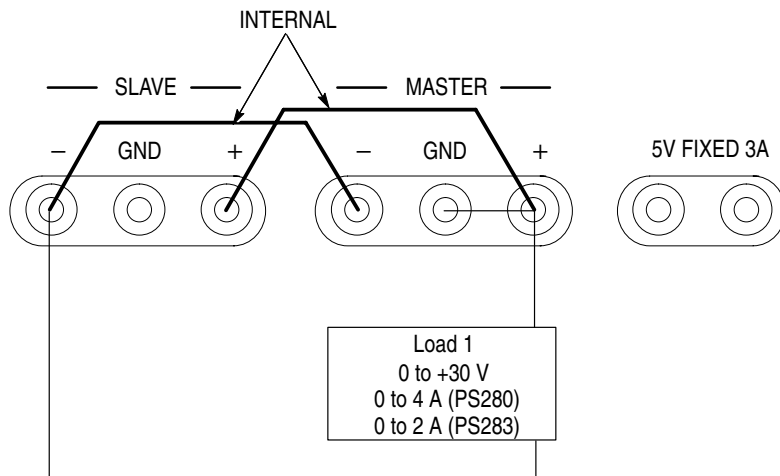

Figure 14: Parallel Tracking Application

7. Adjust the output voltage to the desired level using the master **VOLTAGE** knob.
8. Turn the **POWER** off to the PS280 or PS283 again.
9. Connect the positive polarity of the device being powered to the positive master terminal.
10. Connect the negative polarity of the device being powered to the negative master terminal.



CAUTION. To prevent damage to the PS280 or PS283, do not attempt to obtain output simultaneously from both variable power supplies while in parallel tracking mode.

NOTE. The 5 V FIXED supply can be independently grounded or allowed to float.

Appendix A: Specifications

Table 1: Physical Characteristics

Dimension	Measurement
Width	255 mm (10.0 in)
Height	145 mm (5.7 in)
Depth	335 mm (13.2 in)
Weight	11.5 kg (25.4 lb) PS280 9.0 kg (19.9 lb) PS283

Table 2: Environmental Characteristics

Characteristic	Temperature	Relative Humidity
Storage	-10°C to +70°C	70%
Operating	0°C to 40°C	80%

Table 3: Operational Characteristics

Characteristic	Measurement
Outputs	Two 0 to 30 VDC, one 5 VDC
Voltage (5 V)	5.0 ±0.25 VDC at 3.0 A maximum foldback current limited
Voltage (0–30 V)	0–30 constant VDC at 2.0 A constant, maximum (PS280) or 1.0 A constant, maximum (PS283)
Line Regulation (5 V)	≤5 mV
Line Regulation (CV)	≤0.01% +3 mV PS280 ≤0.01% + 5 mV PS283

Appendix A: Specifications

Table 3: Operational Characteristics (Cont.)

Characteristic	Measurement
Line Regulation (CC)	$\leq 0.2\% + 3 \text{ mA}$
Load Regulation (5 V)	$\leq 0.2\%$
Load Regulation (CV)	$\leq 0.01\% + 3 \text{ mV}$ (rating current $\leq 3 \text{ A}$) $\leq 0.01\% + 5 \text{ mV}$ (rating current $> 3 \text{ A}$) $\leq 300 \text{ mV}$ (0–60 V single series tracking supply)
Load Regulation (CC)	$\leq 0.2\% + 3 \text{ mA}$
Ripple/Noise (5 V)	$\leq 2 \text{ mV rms}$
Ripple/Noise (CV)	$\leq 1 \text{ mV rms}$, 5 Hz–1 MHz
Ripple (CC)	$\leq 3 \text{ mA rms}$
Temperature Coefficient (CV)	$\leq 300 \text{ ppm}/^\circ\text{C}$
Recovery Time (CV)	$\leq 100 \mu\text{s}$ (time to recover after a 50% load change with 0.5 A minimum)
Tracking Error (Slave)	$\leq 0.5\% + 10 \text{ mV}$ of the master supply
Indicator	Two 3 1/2 digit 0.5 in LED panel display meter
Meter Indicators	0–30 VDC $\pm(0.5\%$ of reading + 2 digits) 0–2 A $\pm(0.5\%$ of reading + 2 digits)
Insulation (Chassis-to-Terminal)	$\geq 20 \text{ M}\Omega$ at DC 500 V
Insulation (Chassis-to-AC Cord))	$\geq 30 \text{ M}\Omega$ at DC 500 V

Table 4: Electrical Characteristics

Characteristic	Measurement
Line voltage	90 to 110 108 to 132 198 to 242 216 to 250, all VAC at 50–60 Hz
Power consumption	386 VA, 300 W maximum (PS280) 265 VA, 200 W maximum (PS283)

Table 5: Certifications and Compliances

EC Declaration of Conformity – EMC	<p>Meets intent of Directive 89/336/EEC for Electromagnetic Compatibility. Compliance was demonstrated to the following specifications as listed in the Official Journal of the European Communities:</p> <p>EN 55011 Class B Radiated and Conducted Emissions</p> <p>EN 50081-1 Emissions: EN 60555-2 AC Power Line Harmonic Emissions</p> <p>EN 50082-1 Immunity: IEC 801-2 Electrostatic Discharge Immunity IEC 801-3 RF Electromagnetic Field Immunity IEC 801-4 Electrical Fast Transient/Burst Immunity IEC 801-5 Power Line Surge Immunity</p>
EC Declaration of Conformity – Low Voltage	<p>Compliance was demonstrated to the following specification as listed in the Official Journal of the European Communities:</p> <p>Low Voltage Directive 73/23/EEC, amended by 93/68/EEC.</p> <p>HD401 S1 Safety Requirements for Electronic Measuring Aparatus.</p>

Appendix A: Specifications

Appendix B: Maintenance

This appendix provides information for the basic maintenance of the PS280 or PS283 Laboratory DC Power Supply.

Cleaning

To clean the Laboratory DC Power Supply, use a soft cloth dampened in a solution of mild detergent and water. Do not spray cleaner directly onto the instrument, since it may leak into the cabinet and cause damage.

Do not use chemicals containing benzene, benzene, toluene, xylene, acetone, or similar solvents.

Do not use abrasive cleaners on any portion of the power supply.

Preparing for Shipment

If the original packaging is unfit for use or not available, use the following packaging guidelines:

1. Use a corrugated cardboard shipping carton having inside dimensions at least three inches greater than the instrument dimensions.
2. Put the instrument into a plastic bag or wrap to protect it from dampness and loose packing material.
3. Place the instrument into the box and firmly stabilize it with packing material.
4. Seal the carton with shipping tape.

Troubleshooting

Electronic maintenance on the power supply must be performed by a trained technician. However, an operator can perform some basic and routine maintenance. Perform the following steps to isolate the fault:

1. The power switch is on. The instrument is plugged in. Neither the C.C. nor the C.V. indicator is lighted.

Check the output terminals with a voltmeter.

- a. Set the voltage control of the voltmeter to midrange.
- b. Ensure that the range and polarity settings are correct.
- c. Place the voltmeter jacks in the PS280 or PS283 output terminals.
- d. Determine if the terminals are producing any output.

Are the outputs working?

Yes Go to step 2.

No Go to step 3.

2. Refer to a service technician.



WARNING. To prevent electrical shock, unplug the power cord and disconnect the test cables from any power source before checking or replacing the fuse.

3. Check the fuse with a multimeter.

- a. Set the multimeter to the low ohms range.
- b. Apply the multimeter probes across the fuse.
- c. Determine if a continuous circuit exists.

Is the fuse okay?

Yes Go to step 5.

No Go to step 4.

4. Replace the fuse.

5. Verify that the line settings on the rear panel match the line voltage. Do they?
Yes Go to step 7.
No Go to step 6.
6. Reset the line settings. Refer to *Preparing the Power Supply for Use* on page 2.
7. Check the power cord.



WARNING. *To prevent personal injury, be sure the power cord is disconnected at both ends before you check it.*

- Is the power cord frayed or broken?
- Yes Go to step 8.
No Go to step 2.
8. Replace the power cord.
 9. The power switch is on. A variable output power supply is connected to a circuit. The C.C. or C.V. indicator is on. Neither variable output power supply is producing any electrical output.

Disconnect the instrument from the circuit. Check the output terminals with a voltmeter. Are the outputs working?
Yes Go to step 10.
No Go to step 2.
 10. Check the circuit you have been testing for a short or low resistance.

Appendix B: Maintenance

Appendix C: Replaceable Parts

Replaceable parts may be ordered directly from your authorized Tektronix dealer.

Standard Accessories

The following items are shipped with the Laboratory DC Power Supply:

Table 6: Standard Accessories

Accessory	Tektronix Part Number
Fuse, 5 x 20 mm, 4 A, 250 V, SB (PS280: 90 – 132 V operation)	159-0297-00
Fuse, 5 x 20 mm, 2.5 A, 250 V, SB (PS283: 90 – 132 V operation)	159-0226-00
Test Leads	196-3201-00
User Manual	070-8355-XX
115 V Power Cord	Refer to Table 8

Optional Accessories

The following items are available as optional accessories:

Table 7: Optional Accessories

Accessory	Tektronix Part Number
Fuse, 5 x 20 mm, 2 A, 250 V, SB (PS280: 198 – 250 V operation)	159-0107-00
Fuse, 5 x 20 mm, 1.25 A, 250 V, SB (PS283: 198 – 250 V operation)	159-0247-00
230 V Power Cords	Refer to Table 8

Appendix C: Replaceable Parts

The following power cords are available:

Table 8: Accessory Power Cords

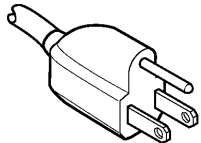
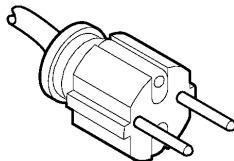
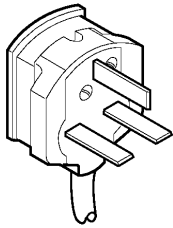
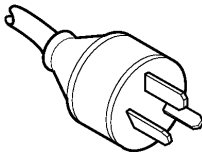
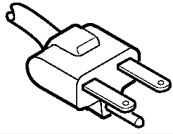
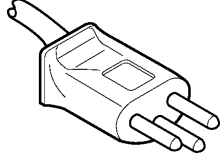
Plug Configuration	Normal Usage	Tektronix Part Number
	North America 115 V	161-0104-00
	Europe 230 V	161-0104-06
	United Kingdom 230 V	161-0104-07
	Australia 230 V	161-0104-05
	North America 230 V	161-0104-08
	Switzerland 230 V	161-0167-00