

# Instruction Manual

**Tektronix**

**P6339A**

**500 MHz Buffered Passive Probe**

**071-0178-01**

**Warning**

The servicing instructions are for use by qualified personnel only. To avoid personal injury, do not perform any servicing unless you are qualified to do so. Refer to all safety summaries prior to performing service.

**[www.tektronix.com](http://www.tektronix.com)**

Copyright © Tektronix, Inc. All rights reserved.

Tektronix products are covered by U.S. and foreign patents, issued and pending. Information in this publication supercedes that in all previously published material. Specifications and price change privileges reserved.

Tektronix, Inc., P.O. Box 500, Beaverton, OR 97077

TEKTRONIX, TEK, TEKPROBE, and SureFoot are registered trademarks of Tektronix, Inc. KlipChip is a trademark of Tektronix, Inc.

Copyright © Tektronix, Inc. All rights reserved.

## WARRANTY

Tektronix warrants that the products that it manufactures and sells will be free from defects in materials and workmanship for a period of one (1) year from the date of shipment. If a product proves defective during this warranty period, Tektronix, at its option, either will repair the defective product without charge for parts and labor, or will provide a replacement in exchange for the defective product.

In order to obtain service under this warranty, Customer must notify Tektronix of the defect before the expiration of the warranty period and make suitable arrangements for the performance of service. Customer shall be responsible for packaging and shipping the defective product to the service center designated by Tektronix, with shipping charges prepaid. Tektronix shall pay for the return of the product to Customer if the shipment is to a location within the country in which the Tektronix service center is located. Customer shall be responsible for paying all shipping charges, duties, taxes, and any other charges for products returned to any other locations.

This warranty shall not apply to any defect, failure or damage caused by improper use or improper or inadequate maintenance and care. Tektronix shall not be obligated to furnish service under this warranty a) to repair damage resulting from attempts by personnel other than Tektronix representatives to install, repair or service the product; b) to repair damage resulting from improper use or connection to incompatible equipment; c) to repair any damage or malfunction caused by the use of non-Tektronix supplies; or d) to service a product that has been modified or integrated with other products when the effect of such modification or integration increases the time or difficulty of servicing the product.

**THIS WARRANTY IS GIVEN BY TEKTRONIX IN LIEU OF ANY OTHER WARRANTIES, EXPRESS OR IMPLIED. TEKTRONIX AND ITS VENDORS DISCLAIM ANY IMPLIED WARRANTIES OF MERCHANTABILITY OR FITNESS FOR A PARTICULAR PURPOSE. TEKTRONIX' RESPONSIBILITY TO REPAIR OR REPLACE DEFECTIVE PRODUCTS IS THE SOLE AND EXCLUSIVE REMEDY PROVIDED TO THE CUSTOMER FOR BREACH OF THIS WARRANTY. TEKTRONIX AND ITS VENDORS WILL NOT BE LIABLE FOR ANY INDIRECT, SPECIAL, INCIDENTAL, OR CONSEQUENTIAL DAMAGES IRRESPECTIVE OF WHETHER TEKTRONIX OR THE VENDOR HAS ADVANCE NOTICE OF THE POSSIBILITY OF SUCH DAMAGES.**





# Table of Contents

<b>General Safety Summary</b> .....	<b>v</b>
<b>Service Safety Summary</b> .....	<b>vii</b>
<b>Contacting Tektronix</b> .....	<b>ix</b>
<b>Getting Started</b> .....	<b>1</b>
Features and Accessories .....	1
Optional Accessories .....	4
Functional Check .....	4
TekProbe Communication .....	5
DC Offset .....	5
DC Gain and Attenuation .....	6
<b>Operating Basics</b> .....	<b>7</b>
Probe Compensation .....	7
Maximum Input Voltage .....	8
High-Frequency Probe Connections .....	8
<b>Specifications</b> .....	<b>9</b>
<b>Adjustment and Verification Procedures</b> .....	<b>15</b>
Equipment Required .....	16
Preparation .....	17
Remove the Top Cover .....	17
Prepare the Equipment .....	17
Adjustment Locations .....	18
Procedures .....	19
HF Adjust .....	19
Compensate the Probe .....	20
Rise Time and Aberrations .....	21
Output Zero Adjust .....	22
DC Attenuation Accuracy .....	22
Rise Time Check .....	25
Reset DIP Switches and Install Cover .....	26
Test Record .....	27

## Table of Contents

---

<b>Maintenance</b> .....	<b>31</b>
Cleaning .....	31
Replacing TekProbe Interface Pins .....	32
Removing and Replacing the TekProbe Interface Collar .....	33
Removing and Replacing the Cable Assembly .....	34
<b>Replaceable Parts</b> .....	<b>35</b>

## List of Figures

<b>Figure 1: SMK4 Micro KlipChip adapter</b> .....	<b>4</b>
<b>Figure 2: Probe compensation waveforms</b> .....	<b>7</b>
<b>Figure 3: Ground lead effects</b> .....	<b>8</b>
<b>Figure 4: Voltage derating, typical</b> .....	<b>11</b>
<b>Figure 5: Input impedance, typical</b> .....	<b>12</b>
<b>Figure 6: Input phase, typical</b> .....	<b>12</b>
<b>Figure 7: Location adjustments and DIP switches</b> .....	<b>18</b>
<b>Figure 8: Setup for probe compensation and high frequency adjustment</b> .....	<b>20</b>
<b>Figure 9: Probe compensation waveforms</b> .....	<b>20</b>
<b>Figure 10: Setup for rise time and aberrations</b> .....	<b>21</b>
<b>Figure 11: Setup for the output offset adjustment</b> .....	<b>22</b>
<b>Figure 12: Setup for DC attenuation accuracy</b> .....	<b>23</b>
<b>Figure 13: Setup for rise time check</b> .....	<b>25</b>
<b>Figure 14: Replacing TekProbe interface pins</b> .....	<b>32</b>
<b>Figure 15: Replacing the TekProbe collar</b> .....	<b>33</b>
<b>Figure 16: Replacing the cable assembly</b> .....	<b>34</b>
<b>Figure 17: P6339A replaceable parts and standard accessories</b> .....	<b>35</b>

## List of Tables

<b>Table 1: Features and accessories</b> .....	<b>2</b>
<b>Table 2: Electrical specifications</b> .....	<b>9</b>
<b>Table 3: Environmental characteristics</b> .....	<b>11</b>
<b>Table 4: Physical characteristics</b> .....	<b>13</b>
<b>Table 5: Certifications and compliances</b> .....	<b>13</b>
<b>Table 6: Test equipment</b> .....	<b>16</b>
<b>Table 7: DIP switch/attenuation settings</b> .....	<b>19</b>
<b>Table 8: Input voltages for DC attenuation accuracy adjustment</b> .....	<b>24</b>
<b>Table 9: Settings for rise time check</b> .....	<b>26</b>





# General Safety Summary

Review the following safety precautions to avoid injury and prevent damage to this product or any products connected to it. To avoid potential hazards, use this product only as specified.

*Only qualified personnel should perform service procedures.*

## To Avoid Fire or Personal Injury

**Connect and Disconnect Properly.** Connect the probe output to the measurement instrument before connecting the probe to the circuit under test. Disconnect the probe input and the probe ground from the circuit under test before disconnecting the probe from the measurement instrument.

**Observe All Terminal Ratings.** To avoid fire or shock hazard, observe all ratings and markings on the product. Consult the product manual for further ratings information before making connections to the product.

The common terminal is at ground potential. Do not connect the common terminal to elevated voltages.

**Do Not Operate Without Covers.** Do not operate this product with covers or panels removed.

**Do Not Operate With Suspected Failures.** If you suspect there is damage to this product, have it inspected by qualified service personnel.

**Do Not Operate in Wet/Damp Conditions.**

**Do Not Operate in an Explosive Atmosphere.**

**Keep Product Surfaces Clean and Dry.**

## Safety Terms and Symbols

**Terms in This Manual.** These terms may appear in this manual:



**WARNING.** *Warning statements identify conditions or practices that could result in injury or loss of life.*

---



**CAUTION.** *Caution statements identify conditions or practices that could result in damage to this product or other property.*

---

**Terms on the Product.** These terms may appear on the product:

DANGER indicates an injury hazard immediately accessible as you read the marking.

WARNING indicates an injury hazard not immediately accessible as you read the marking.

CAUTION indicates a hazard to property including the product.

**Symbols on the Product.** These symbols may appear on the product:



CAUTION  
Refer to Manual



WARNING  
High Voltage



Double  
Insulated



Protective Ground  
(Earth) Terminal



# Service Safety Summary

Only qualified personnel should perform service procedures. Read this *Service Safety Summary* and the *General Safety Summary* before performing any service procedures.

**Do Not Service Alone.** Do not perform internal service or adjustments of this product unless another person capable of rendering first aid and resuscitation is present.

**Use Care When Servicing with Power On.** Dangerous voltages or currents may exist in this product. Disconnect power, remove battery (if applicable), and disconnect test leads before removing protective panels, soldering, or replacing components.

To avoid electric shock, do not touch exposed connections.





# Contacting Tektronix

<b>Phone</b>	1-800-833-9200*
<b>Address</b>	Tektronix, Inc. Department or name (if known) 14200 SW Karl Braun Drive P.O. Box 500 Beaverton, OR 97077 USA
<b>Web site</b>	<a href="http://www.tektronix.com">www.tektronix.com</a>
<b>Sales support</b>	1-800-833-9200, select option 1*
<b>Service support</b>	1-800-833-9200, select option 2*
<b>Technical support</b>	Email: <a href="mailto:techsupport@tektronix.com">techsupport@tektronix.com</a> 1-800-833-9200, select option 3* 1-503-627-2400 6:00 a.m. – 5:00 p.m. Pacific time

---

\* **This phone number is toll free in North America. After office hours, please leave a voice mail message. Outside North America, contact a Tektronix sales office or distributor; see the Tektronix web site for a list of offices.**





# Getting Started

The P6339A Buffered Passive Probe is specifically designed for Tektronix oscilloscopes such as the TDS 794D. Each high-bandwidth input of these oscilloscopes has a fixed 50  $\Omega$  impedance and a TekProbe III interface. To allow a broader range of measurement applications, the P6339A probe passively attenuates and then actively buffers the signal to match the 50  $\Omega$  input impedance.

Key probe specifications include the following:

- 500 MHz bandwidth
- 8 pF input capacitance
- 10 M $\Omega$  passive input (10X)

The oscilloscope settings control the following parameters of the buffered probe output:

- Attenuation and gain
- AC/DC coupling
- Bandwidth limit
- DC offset

For a complete list of specifications, refer to page 9.

## Features and Accessories

Table 1 illustrates the user features of the P6339A Buffered Passive Probe and standard accessories. In addition to those items shown, the standard accessories also include the following:

- Adjustment tool for probe compensation
- Accessory pouch
- Instructions (this manual)

**Table 1: Features and accessories**

Feature/Accessory	Description	Applications/Notes
	<p>Marker bands</p>	<p>Color codes the probe to the oscilloscope input when more than one probe is in use. Clip one band around the strain relief of the probe head and the matching band on the strain relief of the probe compensation box.</p>
 <p>Ground collar</p> <p>Ground lead</p> <p>Ridged probe cover</p>	<p>Short ground lead</p>	<p>Connects the probe ground to a ground reference close to the signal source.</p> <p>To install, slip the ground collar onto the probe head then screw the ridged probe cover down over the probe tip. Insert the socket end of the ground lead into the hole of the ground collar.</p>
	<p>Retractable hook tip</p>	<p>Connects the probe tip to wires and component leads for hands-free measurement.</p> <p><b>NOTE.</b> For a solid connection, firmly push and twist the hook tip onto the probe tip before using.</p>
	<p>SMT KlipChip and ground lead</p>	<p>Connects the probe ground to small or hard to reach ground reference points. The ground lead also connects to a variety of optional accessories.</p>



Table 1: Features and accessories (cont.)

Feature/Accessory	Description	Applications/Notes
	Ground lead with insulated alligator clip	Connects the probe ground to ground reference.
	SureFoot probe tip set	Provides fault-free probing of SMD packages that have lead spacings of 0.50 mm/20 mil (red), 0.65 mm/25 mil (blue), or 50 mil (orange).
	Guard	Keeps fingers away from the probe tip for protection against electric shock.

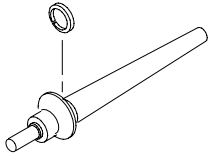
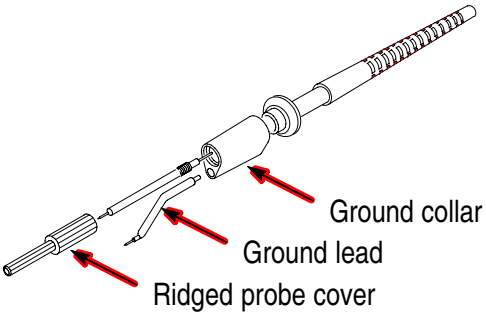
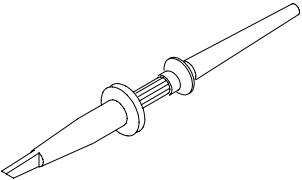
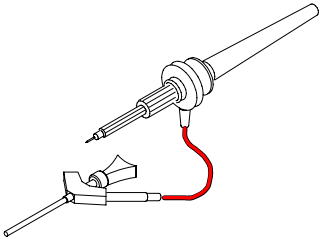
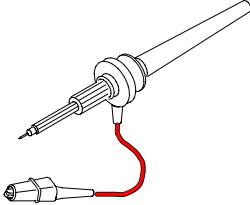
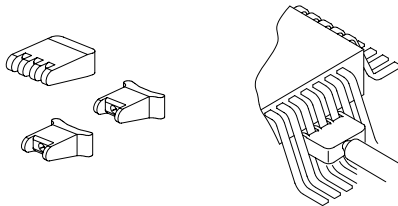
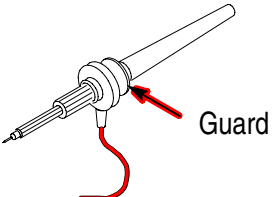

**WARNING.** To avoid electric shock when using the probe, keep fingers behind the guard on the probe body.

Ordering information for replaceable parts and standard accessories begins on page 35.

## Optional Accessories

Recommended optional accessories include the SMK4 shown in Figure 1. This adapter enables connections to very small leads.

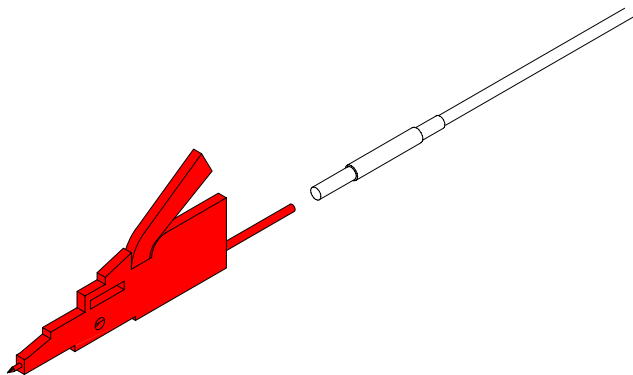

**Figure 1: SMK4 Micro KlipChip adapter**

The P6339A probe is fully compatible with the entire line of 3.5 mm (compact) accessories.

Ordering information for optional accessories begins on page 35.

## Functional Check

Use the functional check procedures in this section to verify basic probe operation with Tektronix oscilloscopes such as the TDS 794D. Because this is a functional check, no tolerances are given for the measured values.

---

**NOTE.** *To verify warranted specifications and to adjust the probe, qualified service personnel may use the adjustment and verification procedures that begin on page 15.*

---

**TekProbe Communication**

This procedure verifies the operation of the TekProbe III interface.

1. Turn on the oscilloscope. Wait for the power up self test to complete.
2. Disconnect all cables or probes from the inputs.
3. Press the Autoset button.
4. Press the CH 1 button.
5. Use the Vertical Scale knob to set the vertical scale factor to 100 mV/div.
6. Press the Vertical Menu button.
7. Attach the probe to the CH 1 input.
8. Select the Coupling menu.
9. Verify that AC and DC coupling and GND are selectable by switching between them.
10. Verify that the channel 1 scale factor is selectable from 10mV/div to 100V/div.
11. Verify that the Bandwidth is selectable between Full, 20MHz and 150MHz (2nd button along lower bezel).

**DC Offset**

This procedure verifies that the oscilloscope can compensate for the DC offset of each volts/division range of the the P6339A probe.

1. With the probe attached to channel 1, set the oscilloscope to the lowest volts/division setting (10 mV/div).
2. Set the input coupling to GND and set the ground reference to center screen.
3. Install a retractable hook tip and ground lead on the probe head.
4. Short the input of the probe to probe ground by connecting a short jumper from the hook tip to the ground lead.
5. Set the coupling to DC.

6. Check that the ground reference for each volts per division range from 10mV/div to 100V/div stays near center screen.

### **DC Gain and Attenuation**

This procedure verifies the correct gain and attenuation of each volts/division range of the probe.

1. With the probe attached to channel 1, set the oscilloscope to the lowest volts/division setting (10 mV/div).
2. Connect the output of a standard amplitude calibration generator or calibrated DC source to the input of the probe.
3. Set the oscilloscope to DC coupling.
4. For each volts per division range from 10mV/div to 100V/div, adjust the generator or DC source to display four or five divisions of vertical deflection and check that the measured value of the input agrees with the output of the generator or DC source.

This completes the functional check procedure.

# Operating Basics

To obtain the best performance from the P6339A probe, compensate the probe as needed, observe the maximum input voltage and make appropriate probe connections.

## Probe Compensation

Due to variations in oscilloscope input characteristics, probe low-frequency compensation may need adjustment after moving the probe from one oscilloscope to another. If a 1 kHz calibrated square wave displayed at 1 ms/division shows significant differences between the leading and trailing edges, perform the following steps to optimize low-frequency compensation.

1. Connect the probe to the calibration signal on the oscilloscope front panel.
2. Press **AUTOSET** or otherwise adjust your digitizing oscilloscope to display a meaningful waveform.
3. Adjust the trimmer in the probe (accessible through the compensation box) until you see a perfectly flat-top square wave on the display. See Figure 2.

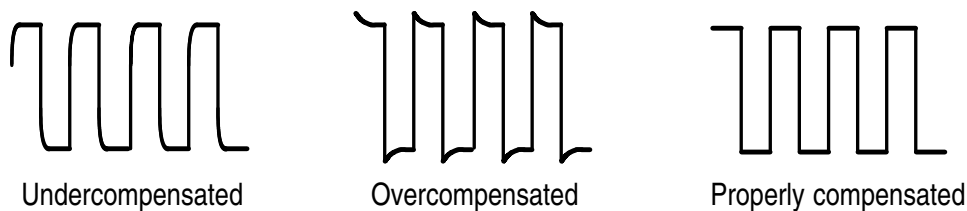

**Figure 2: Probe compensation waveforms**

## Maximum Input Voltage

Estimate the RMS voltage of a pulse signal before measurement. The combination of pulse width, duty factor, and DC level determine the RMS signal voltage. Depending on the application or “installation category,” this voltage must not exceed the ratings listed in the *Specifications* section on page 10.



---

**WARNING.** *To avoid electric shock when using the probe, do not touch the metallic portions of the probe head while connected to a voltage source.*

---

## High-Frequency Probe Connections

To minimize inductive effects that cause ringing at high frequencies, keep all signal and ground leads as short as possible (see Figure 3). Accessories are included with the probe that provide convenient means to make short connections (see page 2).

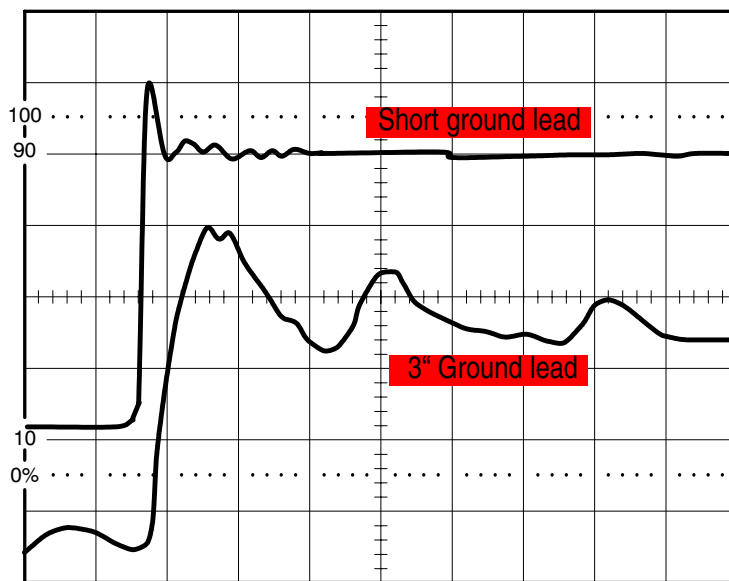

Figure 3: Ground lead effects

# Specifications

All specifications in Table 2 apply to the probe only unless marked as system. The system specifications apply when the P6339A probe is operated with a TDS 794D in an environment that does not exceed the limits described in Table 3 on page 11.

All specifications are warranted unless marked as typical. The ✓ symbol indicates warranted specifications that have checks in the *Adjustment Procedures* section.

**Table 2: Electrical specifications**

System input resistance, typical	10 M $\Omega$ at DC (DC coupled), see Figure 5
System input capacitance, typical	8.0 pF at 1 kHz (DC coupled), see Figure 5
System bandwidth, calculated	DC to 500 MHz at 50 mV/div
System dynamic range, typical	$\pm 10$ divisions at each V/div setting except 50 V and 100 V/div <sup>1</sup>
System offset range, typical	$\pm 10$ divisions
System output zero, typical	$\pm 0.6$ division or less displayed on screen after probe cal
Aberrations, typical (probe only)	+8%, -6% at 10 mV/div +16%, -6% at 20 mV, 50 mV, 0.1 V, and 0.2 V/div +18%, -6% at 0.5 V/div +21%, -6% at 1 V/div +22%, -6% at 2 V/div +24%, -6% at 5 V/div +35%, -17% at 10 V/div
AC coupling, typical lower bandwidth	< 10 Hz

**Table 2: Electrical specifications (cont.)**

✓ Output zero (probe only)	± 20 mV at 10 mV/div, ± 10 mV at 20 mV/div, ± 5 mV at all other V/div settings
✓ DC attenuation accuracy (probe only)	± 2.0 % at 10 mV, 20 mV, 50 mV, 0.1 V, 0.2 V, 0.5 V, 1 V, 2 V, 5 V, 10 V, 20 V, and 50 V/div ± 4.0 % at 100 V/div
✓ Rise time (probe only)	1.4 ns at 10 mV/div 875 ps at 20 mV/div 700 ps at 50 mV, 0.1 V, 0.2 V, 0.5 V, 1 V, 2 V, and 5 V/div 870 ps at 10 V/div
Required output termination	50 Ω
Bandwidth limit frequencies (–3 dB), typical	20 MHz and 150 MHz
Time delay, typical	7.8 ns ± 1 ns
Maximum rated input voltage, probe tip to earth ground	Overvoltage category I: 600 V <sub>PK</sub> (DC + peak AC)  Overvoltage category II: 300 V <sub>RMS</sub>  Category III: 150 V <sub>RMS</sub>
Voltage derating, typical	See Figure 4
Input impedance, typical	See Figure 5
Input phase, typical	See Figure 6

<sup>1</sup> **Full dynamic range at 50 V and 100 V/div would exceed the safety rating of the probe.**



**Table 3: Environmental characteristics**

Temperature	<p>Operating: +10° C to + 50° C (+50° F to +122° F)</p> <p>Nonoperating -22° C to +60° C (-7.6° F to +140° F)</p>
Humidity	<p>Operating and Nonoperating: Five cycles (120 hr total) at 80% to 85% relative humidity</p>
Altitude, operating	<p>&lt; 2000 m (&lt; 6,562 ft), rated ranges</p> <p>2000 to 5000 m (6,562 to 16,404 ft) voltage ratings reduced to 300 V CAT I and 150 V CAT II</p>
Altitude, non-operating	< 15,240 meters (50,000 ft)

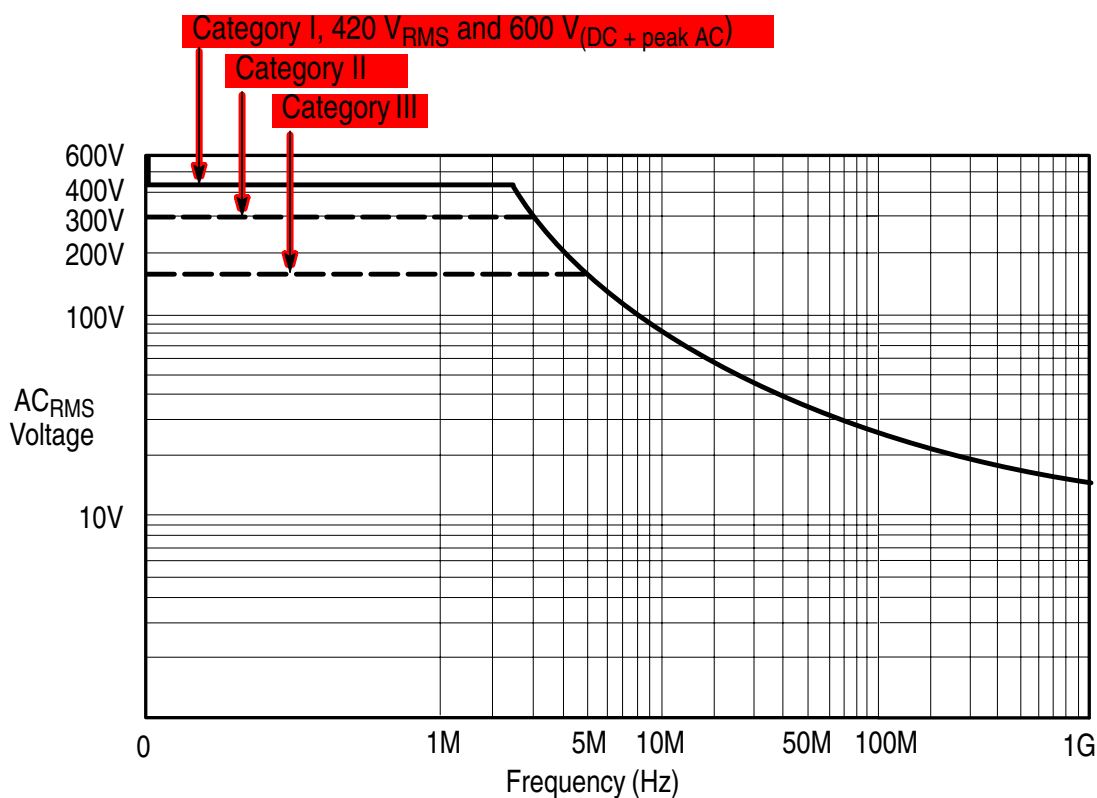

**Figure 4: Voltage derating, typical**

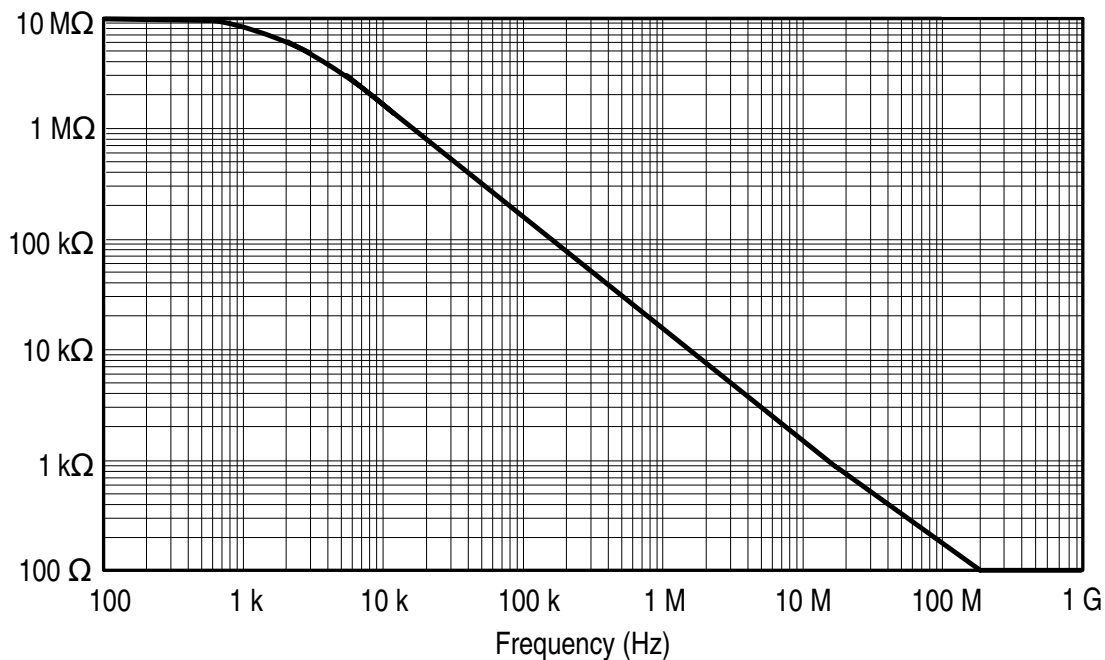

Figure 5: Input impedance, typical

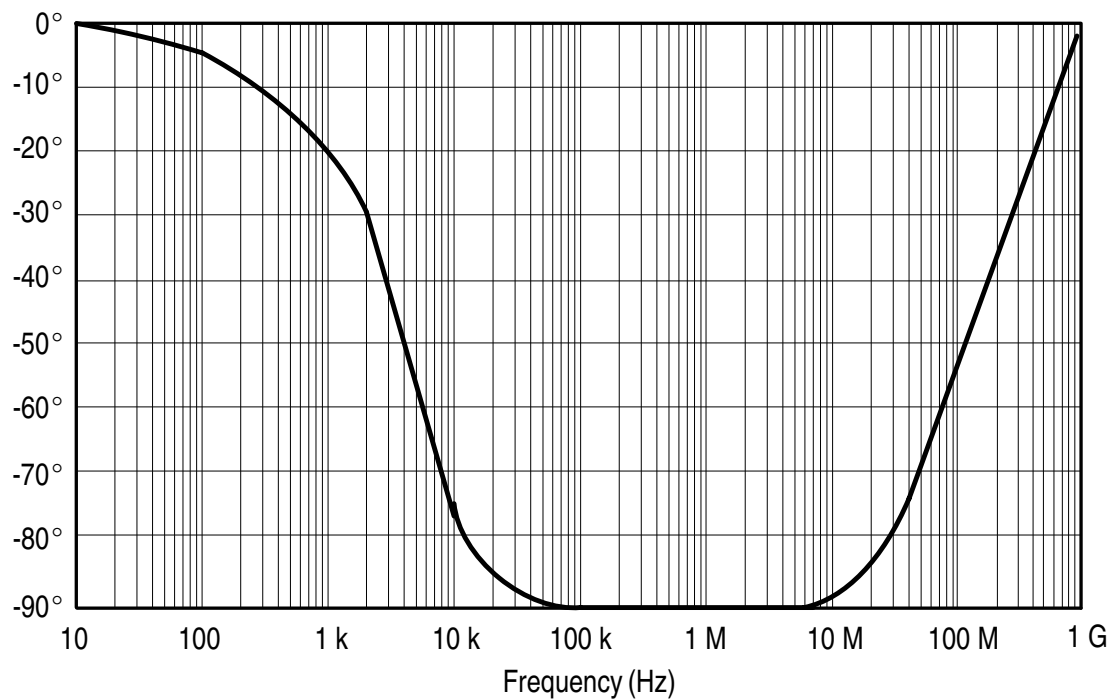

Figure 6: Input phase, typical

Table 4 lists the physical characteristics of the P6339A probe.

**Table 4: Physical characteristics**

Weight, typical	Shipping weight: 515 g (1.2 lbs) including shipping materials Net weight: 185 g (0.41 lbs), probe only
Cable length, typical	1.3 m (51.18 in)

Table 5 lists the certifications and compliances.

**Table 5: Certifications and compliances**

EC Declaration of Conformity – Low Voltage	Compliance was demonstrated to the following specification as listed in the Official Journal of the European Union:  Low Voltage Directive 73/23/EEC, amended by 93/69/EEC EN 61010-2-031:1994 Particular requirements for hand-held probe assemblies for electrical measurement and test equipment.
U.S. Nationally Recognized Testing Laboratory Listing	UL3111-1 Standard for electrical measuring and test equipment. IEC61010-2-031:1994 Particular requirements for hand-held probe assemblies for electrical measurement and test equipment.
Canadian Certification	CAN/CSA C22.2 No. 1010.1 Safety requirements for electrical equipment for measurement, control, and laboratory use. CAN/CSA C22.2 No. 1010.2.031:1994 Particular requirements for hand-held probe assemblies for electrical measurement and test equipment.
Additional Compliance	IEC61010-1/A2 Safety requirements for electrical equipment for measurement, control, and laboratory use.

**Table 5: Certifications and compliances (cont.)**

<p>Installation (Overvoltage) Category</p>	<p>Terminals on this product may have different installation (overvoltage) category designations. The installation categories are:</p> <p>CAT III Distribution-level mains (usually permanently connected). Equipment at this level is typically in a fixed industrial location.</p> <p>CAT II Local-level mains (wall sockets). Equipment at this level includes appliances, portable tools, and similar products. Equipment is usually cord-connected.</p> <p>CAT I Secondary (signal level) or battery operated circuits of electronic equipment.</p>
<p>Pollution Degree</p>	<p>A measure of the contaminates that could occur in the environment around and within a product. Typically the internal environment inside a product is considered to be the same as the external. Products should be used only in the environment for which they are rated.</p> <p>Pollution Degree 2 Normally only dry, nonconductive pollution occurs. Occasionally a temporary conductivity that is caused by condensation must be expected. This location is a typical office/home environment. Temporary condensation occurs only when the product is out of service.</p>



**WARNING**

*The following servicing instructions are for use only by qualified personnel. To avoid injury, do not perform any servicing other than that stated in the operating instructions unless you are qualified to do so. Refer to all safety summaries before performing any service.*



# Adjustment and Verification Procedures

Use the following procedures to adjust and verify the P6339A Buffered Passive Probe to warranted specifications. Before beginning these procedures, photocopy the test record on pages 27 through 29 and use it to record test results. The recommended adjustment and verification interval is one year.

These procedures adjust and/or verify the following:

- High frequency (adjust)
- Probe compensation (adjust)
- Rise time and aberrations (adjust)
- Output zero (adjust and/or verify)
- DC attenuation accuracy (adjust and verify)
- Rise time (verify)



---

**WARNING.** *These procedures are for use by qualified service personnel only.*

---

## Equipment Required

Table 6 lists the equipment required to perform these procedures. The types and quantities of connectors may vary depending on the specific equipment you use.

**Table 6: Test equipment**

Description	Minimum requirements	Example product
Oscilloscope	TekProbe interface, $\leq 267$ ps risetime	Tektronix TDS694C
Probe power supply	Compatible with the Tek-Probe interface	Tektronix Type 1103
Calibrated DC voltage source	Adjustable from 0 V to 400 V with accuracy $\leq 0.05\%$ .	Wavetek 9100
Digital multimeter	DC Accuracy $\leq 0.1\%$ , $\leq 400$ mV range	Fluke 87 or equivalent
High amplitude pulse generator	0 to 50 V pulse, $\leq 250$ ps rise time	Picosecond Pulse Labs 2700C or 2700B
Male BNC to probe tip adapter	Straight-thru	013-0226-00
Male BNC to 50 $\Omega$ probe tip adapter	50 $\Omega$ nominal	013-0227-00
BNC cable	50 $\Omega$ , 1%, precision	012-0482-00
Dual-male-banana-to-female BNC adapter	As per description	103-0090-00
Precision inline BNC terminator	50 $\Omega \pm 0.1\%$	011-0129-00
Probe tip shorting connector	As per description	
In-line attenuator	50 $\Omega$ , 10X	011-0059-02



## Preparation

Prepare the probe for adjustment as follows:

### Remove the Top Cover

1. Remove the four screws that attach the top cover to the compensation box.
2. Remove the top cover.

### Prepare the Equipment

1. Connect the male BNC to probe tip adapter (013-0226-00) to the input of the probe.
2. Attach the probe to the 1103 TekProbe Power Supply.
3. If necessary, set the line selector to the correct voltage.
4. Turn on the 1103 power supply.
5. Set the offset button to the off position (button not illuminated).
6. Allow at least 20 minutes for the equipment to warm up.

---

**NOTE.** *Ambient temperature must be within 20° C to 30° C when you adjust the probe.*

---

### Adjustment Locations

Figure 7 shows the locations of the adjustments and the DIP switches (S1) that manually set the probe attenuation (gain) range.

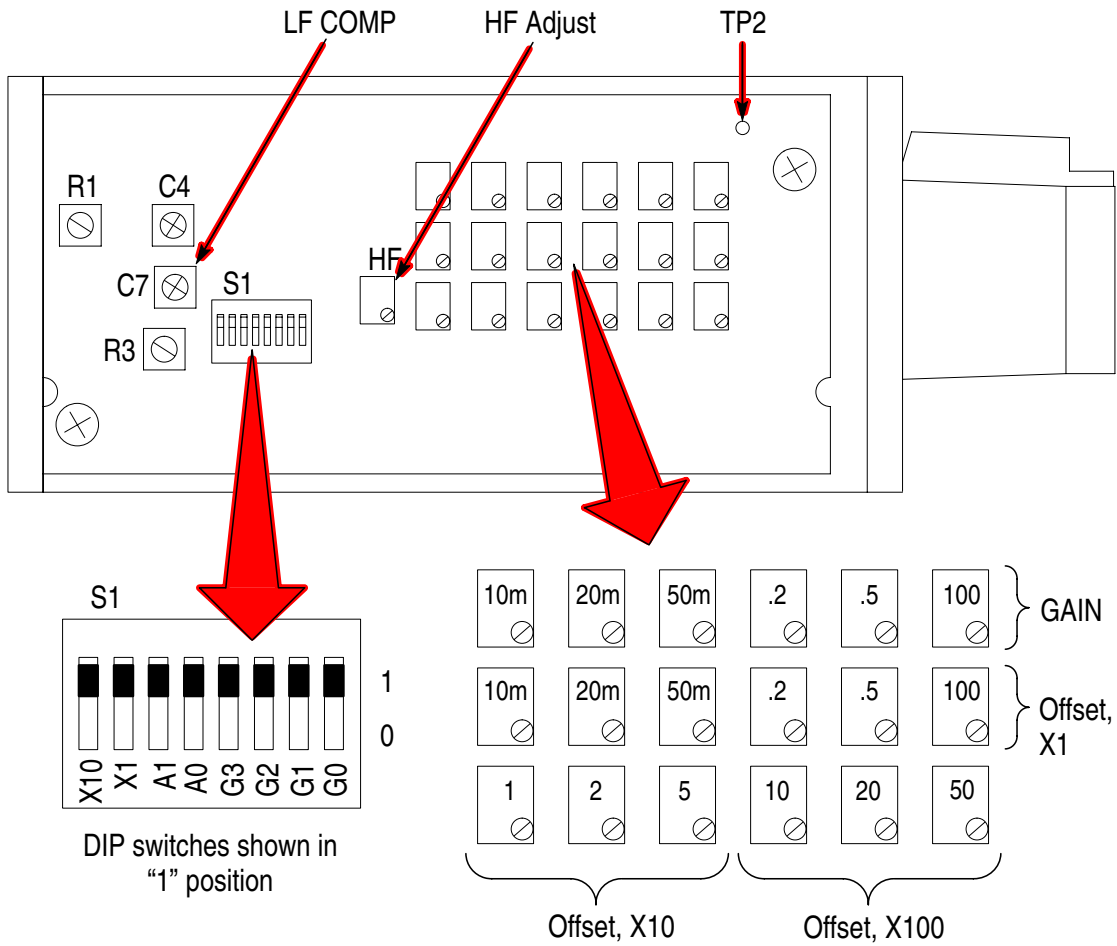

Figure 7: Location adjustments and DIP switches

Because some of these procedures use the TekProbe 1103 Power Supply, there is no automatic control of the probe attenuation. You must manually set the required attenuation for these procedures according to Table 7.

**Table 7: DIP switch/attenuation settings**

Atten. setting	X10	X1	A1	A0	G3	G2	G1	G0	System atten.	System gain
10 mV	0	1	0	1	0	0	0	1	1	1.0000
20 mV					0	0	1	0	2	0.5000
50 mV <sup>1</sup>					0	0	1	1	5	0.2000
0.2 V					0	1	0	0	10	0.1000
0.5 V					0	1	0	1	25	0.04000
1 V	1	0	0	0	0	0	1	1	50	0.02000
2 V					0	1	0	0	100	0.01000
5 V					0	1	0	1	250	0.00400
10 V	1	0	1	0	0	0	1	1	500	0.00200
20 V					0	1	0	0	1000	0.00100
50 V					0	1	0	1	2500	0.000400
100 V					1	1	0	1	5000	0.000200

<sup>1</sup> During normal operation, the probe attenuation for 50 mV/div is the same as 0.1 V/div and the oscilloscope automatically displays the correct waveform. With the 1103, there are no adjustments for 0.1 V/div.

## Procedures

Perform the adjustment and verification procedures in order.

### HF Adjust

1. Setup the equipment as shown in Figure 8 on page 20. (For this procedure, the probe tip does not have to be connected to the probe compensation signal.)

2. Measure the voltage on TP2 with a DMM and set the HF Adjust potentiometer until the voltage at TP2 is  $-0.50 \pm 0.05$  VDC.

### Compensate the Probe

1. Set up the equipment as shown in Figure 8.
2. With the P6339A probe installed on the 1103 power supply, set all the DIP switches to the “0” position. See Figure 7 on page 18.
3. Using Table 7 on page 19, set the DIP switches for 50 mV/div.

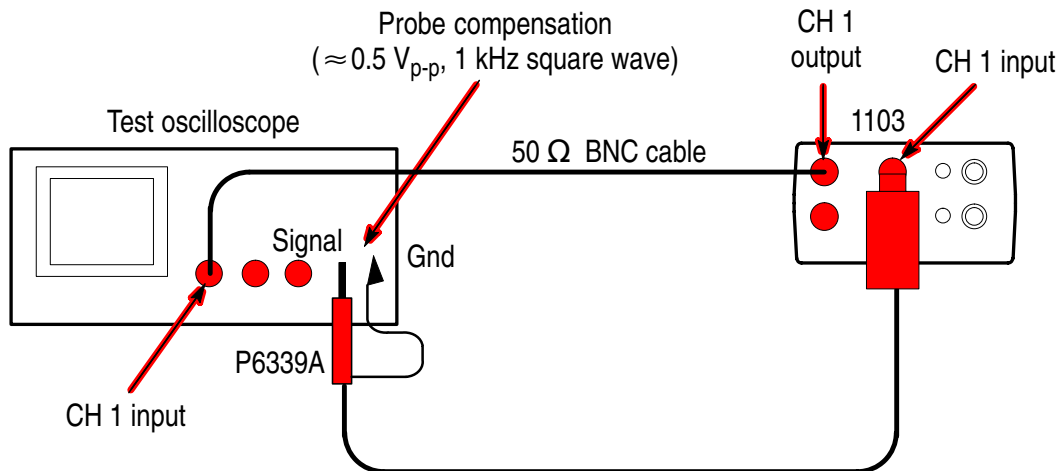

**Figure 8: Setup for probe compensation and high frequency adjustment**

4. Press AUTOSET or otherwise adjust your digitizing oscilloscope to display a meaningful waveform.
5. Adjust the LF COMP trimmer, C7 (Figure 7 on page 18), until you see a perfectly flat-top square wave on the display (Figure 9).

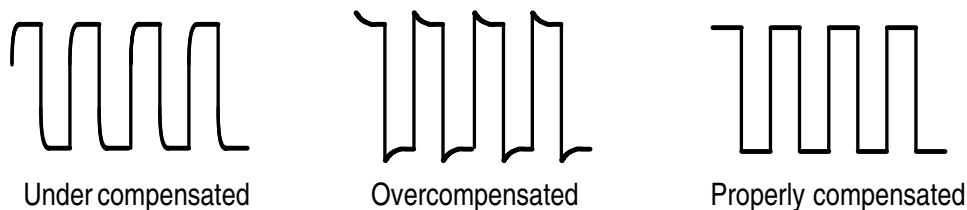

**Figure 9: Probe compensation waveforms**

### Rise Time and Aberrations

1. Set up the equipment as shown in Figure 10.
2. Set all the DIP switches to the “1” position.
3. Set the oscilloscope vertical to 50 mV.
4. Set the pulse generator to 250 mV.
5. Adjust R1 and R3 for a flat response with minimum rise time ( $\leq 700$  ps).
6. Adjust C4 for minimum aberrations in the first 3 ns.

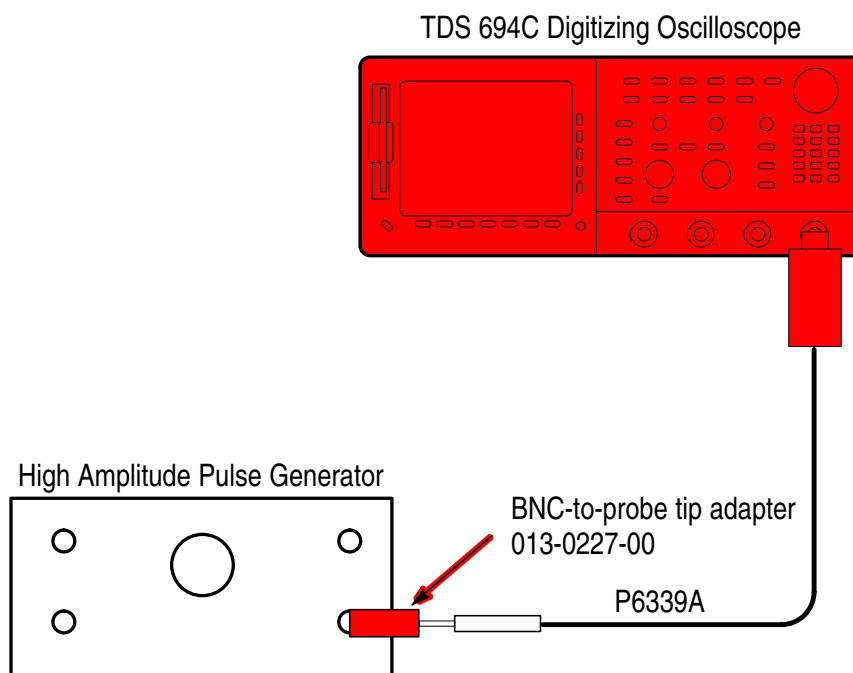

Figure 10: Setup for rise time and aberrations

### Output Zero Adjust

1. Connect the probe as shown in Figure 11.

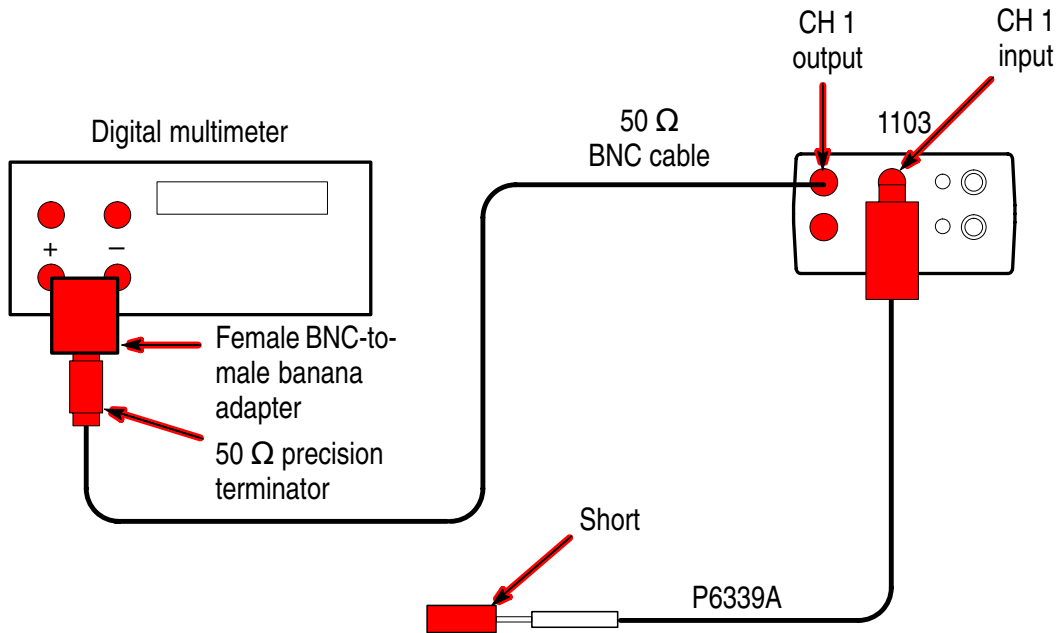

Figure 11: Setup for the output offset adjustment

2. Set the DMM to the mV range.
3. Set all the DIP switches to the “0” position.
4. Set the DIP switches for an attenuation of 10 mV as shown in Table 7.
5. If necessary, adjust the offset potentiometer marked “10m” for a DMM reading of  $0.0 \text{ mV} \pm 1 \text{ mV}$ .
6. Set the DIP switches for each attenuation range listed in Table 7 and adjust the corresponding offset potentiometer for a DMM reading of  $0.0 \text{ mV} \pm 0.5 \text{ mV}$ .

## DC Attenuation Accuracy

1. Connect the probe as shown in Figure 12.

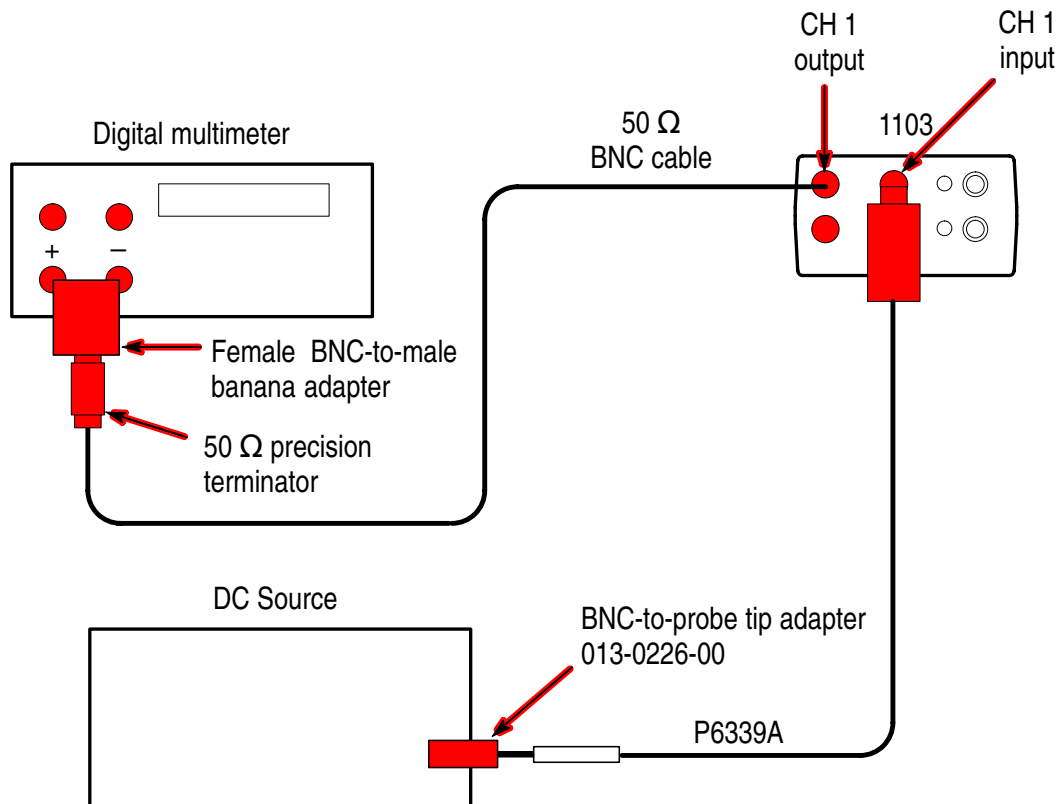

Figure 12: Setup for DC attenuation accuracy

2. Set the DMM to the mV range.
3. Set all the DIP switches to the “0” position.
4. Set the DIP switches for an attenuation of 10 mV and adjust the gain potentiometer marked 10m (top row, left) for the best compromise that produces an output reading on the DMM within the limits listed in Table 8 on page 24 for both positive and negative voltage inputs.

5. In similar fashion, apply the voltages for each subsequent attenuation range listed in Table 8 and check the DMM reading. Adjust the appropriate potentiometer for each range. Note that some ranges do not have an adjustment.

**Table 8: Input voltages for DC attenuation accuracy adjustment**

Attenuation setting	DCV in	DMM reading
10mV (0 1 0 1 0 0 0 1)	+100.00 mV	98.0 mV to 102.0 mV
	-100.00 mV	-102.0 mV to -98.0 mV
20mV (0 1 0 1 0 0 1 0)	+200.00 mV	98.0 mV to 102.0 mV
	-200.00 mV	-102.0 mV to -98.0 mV
50mV (0 1 0 1 0 0 1 1)	+500.00 mV	98.0 mV to 102.0 mV
	-500.00 mV	-102.0 mV to -98.0 mV
0.2 V (0 1 0 1 0 1 0 0)	+1.000 V	98.0 mV to 102.0 mV
	-1.000 V	-102.0 mV to -98.0 mV
0.5 V (0 1 0 1 0 1 0 1)	+2.500 V	98.0 mV to 102.0 mV
	-2.500 V	-102.0 mV to -98.0 mV
1 V <sup>1</sup> (1 0 0 0 0 0 1 1)	+5.000 V	98.0 mV to 102.0 mV
	-5.000 V	-102.0 mV to -98.0 mV
2 V <sup>1</sup> (1 0 0 0 0 1 0 0)	+10.00 V	98.0 mV to 102.0 mV
	-10.00 V	-102.0 mV to -98.0 mV
5 V <sup>1</sup> (1 0 0 0 0 1 0 1)	+25.00 V	98.0 mV to 102.0 mV
	-25.00 V	-102.0 mV to -98.0 mV
10 V <sup>1</sup> (1 0 1 0 0 0 1 1)	+50.00 V	98.0 mV to 102.0 mV
	-50.00 V	-102.0 mV to -98.0 mV
20 V <sup>1</sup> (1 0 1 0 0 1 0 0)	+100.0 V	98.0 mV to 102.0 mV
	-100.0 V	-102.0 mV to -98.0 mV



**Table 8: Input voltages for DC attenuation accuracy adjustment (cont.)**

Attenuation setting	DCV in	DMM reading
50 V <sup>1</sup> (1 0 1 0 0 1 0 1)	+250.0 V	98.0 mV to 102.0 mV
	-250.0 V	-102.0 mV to -98.0 mV
100 V (1 0 1 0 1 1 0 1)	+400.0 V	76.8 mV to 83.2 mV
	-400.0 V	-83.2 mV to -76.8 mV

<sup>1</sup> These ranges do not have adjustments

### Rise Time Check

1. Connect the probe as shown in Figure 13.

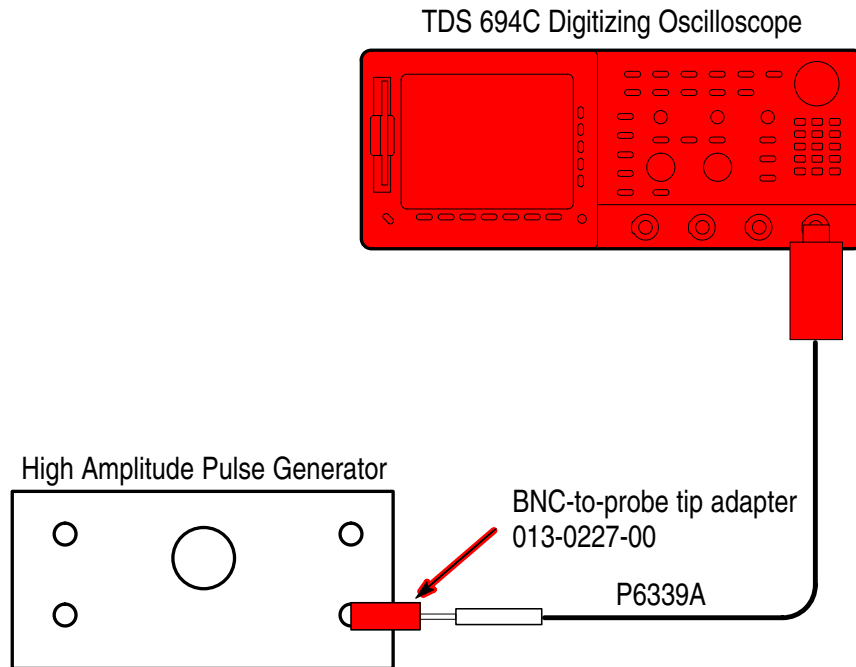

**Figure 13: Setup for rise time check**

2. Set all the DIP switches to the “1” position.

3. Set the pulse generator and check the rise for each attenuation setting listed in Table 9.

**Table 9: Settings for rise time check**

<b>TDS694C attenuation setting</b>	<b>Pulse generator</b>	<b>Rise time</b>
10 mV	50 mV	$\leq 1.4$ ns
20 mV	100 mV	$\leq 875$ ps
50 mV	250 mV	$\leq 700$ ps
0.2 V	1 V	$\leq 700$ ps
0.5 V	2.5 V	$\leq 700$ ps
1 V	5 V	$\leq 700$ ps
2 V	10 V	$\leq 700$ ps
5 V	25 V	$\leq 700$ ps
10 V	50 V	$\leq 870$ ps

### **Reset DIP Switches and Install Cover**

1. Return all DIP switches to the “1” position as shown in Figure 7 on page 18.
2. Place the top cover back onto the compensation box and secure the cover with the four screws removed earlier.

This completes the adjustment and verification procedures.

## Test Record

Photocopy the following test record and use it to record test results.

P6339A Test Record,

Page 1 of 3

Serial Number	Procedure performed by	Date

Oscilloscope tests	Low limit	Test result	High limit
Output zero <sup>1</sup>	10 mV	-20 mV	+20 mV
	20 mV	-10 mV	+10 mV
	50 mV	-5 mV	+5 mV
	0.2 V	-5 mV	+5 mV
	5 V	-5 mV	+5 mV
	1 V	-5 mV	+5 mV
	2 V	-5 mV	+5 mV
	5 V	-5 mV	+5 mV
	10 V	-5 mV	+5 mV
	20 V	-5 mV	+5 mV
	50 V	-5 mV	+5 mV
	100 V	-5 mV	+5 mV

<sup>1</sup> The high and low limits for output zero represent the acceptable limits over time. When making the adjustments, set the 10 mV/div adjustment to  $0.00 \text{ mV} \pm 1.0 \text{ mV}$  and all other adjustments to  $0.00 \text{ mV} \pm 0.5 \text{ mV}$ .

Oscilloscope tests		Low limit	Test result	High limit
DC attenuation accuracy	10 mV ( $\pm 100$ mV in)	+98.0 mV		+102.0 mV
		-102.0 mV		-98.0 mV
	20 mV ( $\pm 200$ mV in)	+98.0 mV		+102.0 mV
		-102.0 mV		-98.0 mV
	50 mV ( $\pm 500$ mV in)	+98.0 mV		+102.0 mV
		-102.0 mV		-98.0 mV
	0.2 V ( $\pm 1.000$ V in)	+98.0 mV		+102.0 mV
		-102.0 mV		-98.0 mV
	0.5 V ( $\pm 2.500$ V in)	+98.0 mV		+102.0 mV
		-102.0 mV		-98.0 mV
	1 V ( $\pm 100$ mV in)	+98.0 mV		+102.0 mV
		-102.0 mV		-98.0 mV
	2 V ( $\pm 200$ mV in)	+98.0 mV		+102.0 mV
		-102.0 mV		-98.0 mV
	5 V ( $\pm 500$ mV in)	+98.0 mV		+102.0 mV
		-102.0 mV		-98.0 mV
	10 V ( $\pm 1.000$ V in)	+98.0 mV		+102.0 mV
		-102.0 mV		-98.0 mV
	20 V ( $\pm 2.500$ V in)	+98.0 mV		+102.0 mV
		-102.0 mV		-98.0 mV
50 V ( $\pm 250.0$ V in)	+98.0 mV		+102.0 mV	
	-102.0 mV		-98.0 mV	
100 V ( $\pm 400.0$ V in)	+76.8 mV		+83.2 mV	
	-83.2 mV		-76.8 mV	

## P6339A Test Record

Page 3 of 3

Oscilloscope tests		Low limit	Test result	High limit
Rise time	10 mV	N/A		1.4 ns
	20 mV	N/A		875 ps
	50 mV	N/A		700 ps
	0.2 V	N/A		700 ps
	0.5 V	N/A		700 ps
	1 V	N/A		700 ps
	2 V	N/A		700 ps
	5 V	N/A		700 ps
	10 V	N/A		870 ps

**NOTE.** Return all DIP switches to the “1” position before installing the top cover on the compensation box.





# Maintenance

The procedures in this section describe how to maintain and repair the P6339A Buffered Passive Probe.

## Cleaning

Remove dirt with a soft cloth dampened in a mild detergent and water solution or isopropyl alcohol.



---

**CAUTION.** *To avoid damaging the probe, use only a mild detergent and water solution or isopropyl alcohol; do not use any other solvents or abrasive cleaners. Do not immerse the probe.*

---

## Replacing TekProbe Interface Pins

1. To remove the interface pin, grasp the pin with a pair of needle-nose pliers and gently pull the pin out. See Figure 14.
2. To replace the pin, insert the new pin into the socket and press it in against a hard surface.

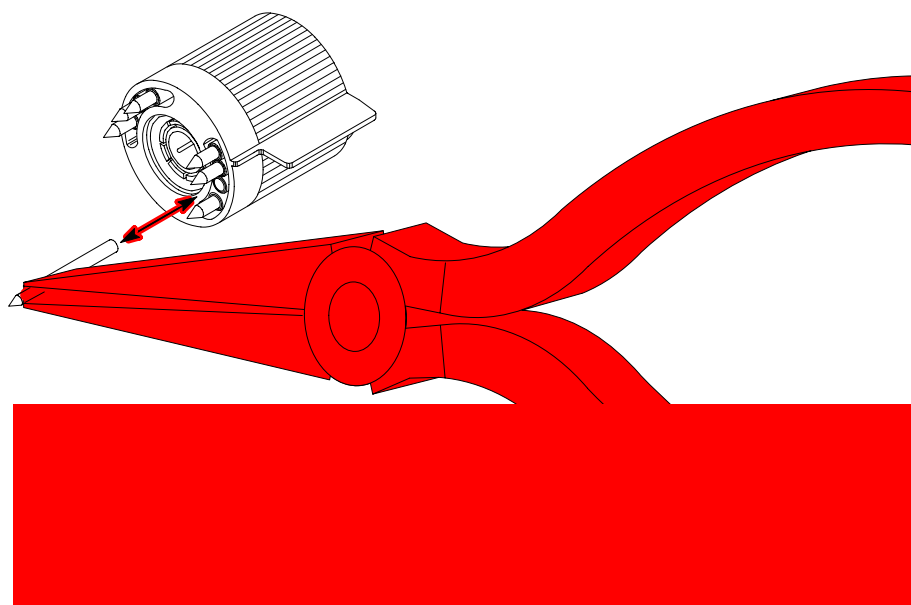

Figure 14: Replacing TekProbe interface pins



## Removing and Replacing the TekProbe Interface Collar

1. To remove the collar, firmly pull the collar off by hand.
2. To replace the collar, align the smaller group of pins with the smaller of the two holes in the interface collar and align the tabs with the slots. Gently press the two pieces together. See Figure 15.

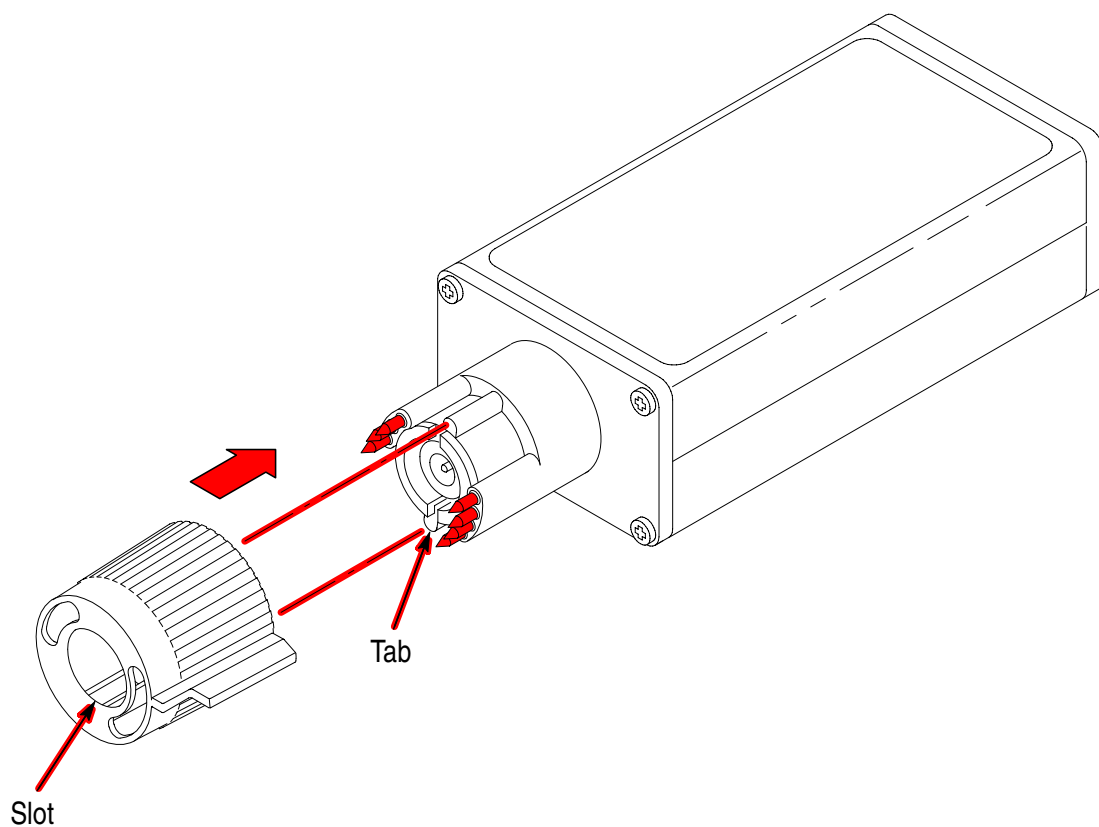

Figure 15: Replacing the TekProbe collar

## Removing and Replacing the Cable Assembly

1. Unscrew the retaining nut and slide it back on the cable.
2. Firmly grasp the cable close to the threaded housing and pull it straight out.
3. Remove the nut from the old cable and place it onto the new cable.
4. Insert the new cable into the housing until it snaps into place.
5. Tighten the retaining nut (approximately 30 inch-lbs).

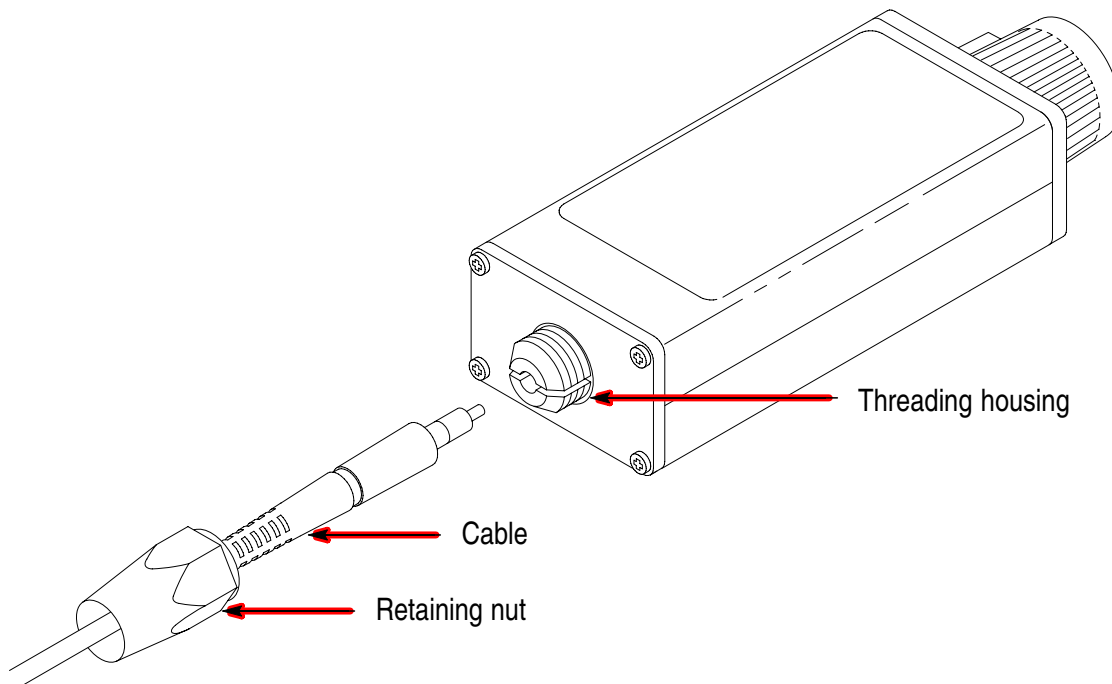

Figure 16: Replacing the cable assembly

# Replaceable Parts

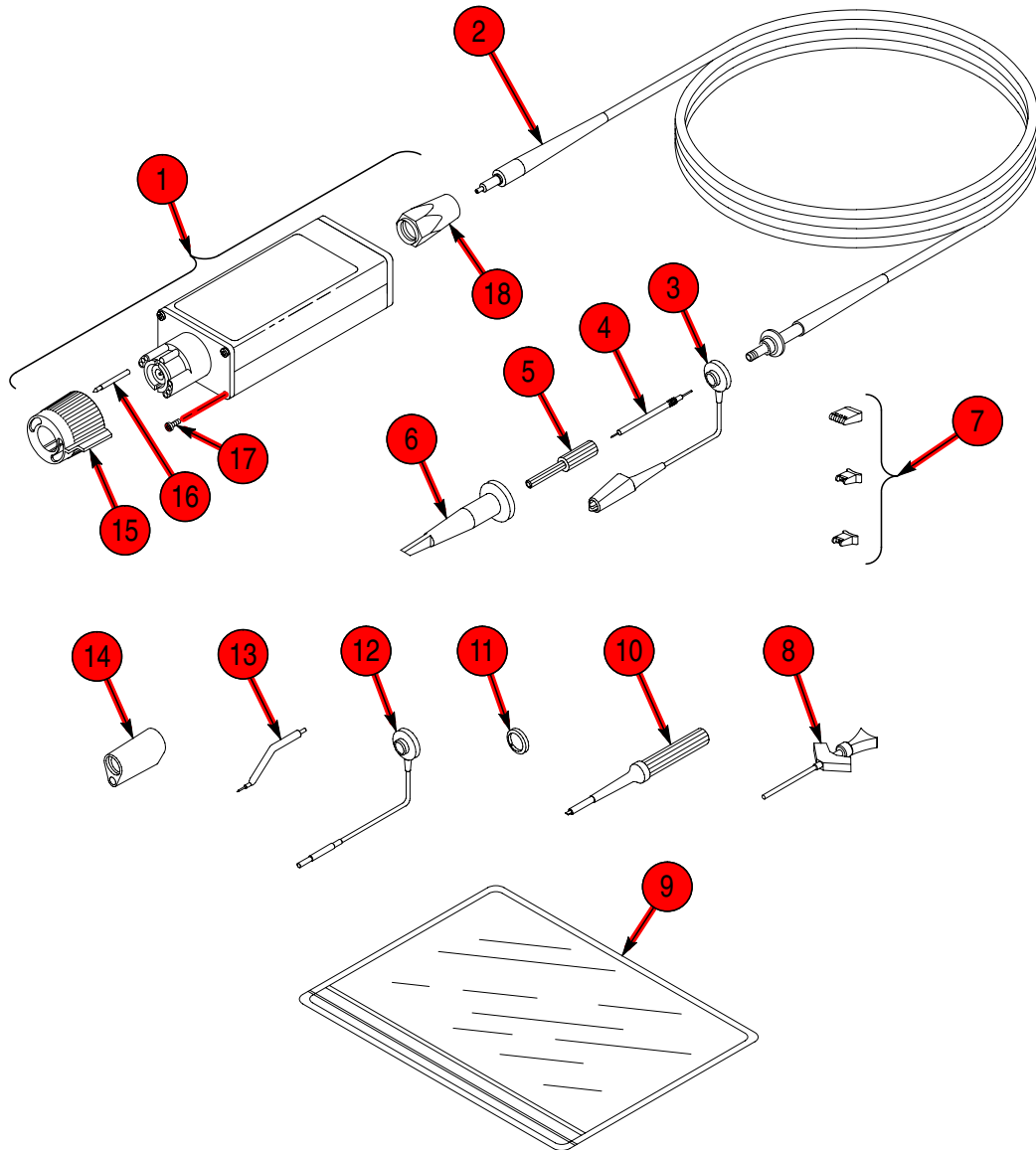

Figure 17: P6339A replaceable parts and standard accessories

**P6339A and replaceable parts and accessories**

Fig. & index number	Tektronix part number	Serial no. effective	Serial no. discont'd	Qty	Name & description	Mfr. code	Mfr. part number
17-1	206-0485-00			1	COMP BOX ASSY:P6339A	80009	206-0485-00
-2	174-0978-00			1	CABLE ASSY,RF:65 OHM COAX PER FT,1.3M	060D9	174-0978-00
-3	196-3305-00			1	LEAD,ELECTRICAL:22 AWG,6.0 L,W/CLIP	060D9	196-3305-00
-4	206-0441-00			1	PROBE TIP ASSY:10X,8.0PF,9M OHM,	80009	206-0441-00
-5	204-1049-00			1	BODY SHELL:TIP COVER	TK2565	204-1049-00
-6	013-0107-07			1	TIP,PROBE:MINIATURE/COMPACT SIZE	TK2565	013-0107-07
-7	See Optional Accessories			1	ADAPTER,SMD KIT 2 EA 0.50 mm/20 mil (red), 0.65 mm/25 mil (blue), and 50 mil (orange)	80009	See Optional Accessories
-8	206-0364-00			1	TIP,PROBE:MICROCKT TEST,0.05 CTR	80009	206-0364-00
-9	_____			1	POUCH (not replaceable)		
-10	003-1433-03			1	SCREWDRIVER:ADJUSTMENT TOOL,METAL TIP	TK2565	003-1433-03
-11	016-0633-00			1	MARKER SET,CA:2 EA VARIOUS COLORS	80009	016-0633-00
-12	196-3113-02			1	LEAD,ELECTRICAL:STRD,22 AWG,6.0 L,8-N	060D9	196-3113-02
-13	195-4240-00			1	LEAD,ELECTRICAL:0.025 DIA,COPPER,2.3 L	060D9	195-4240-00
-14	343-1003-01			1	COLLAR,GND:P6130	TK2565	343-1003-01
-15	205-0191-01			1	SHELL,ELEC CONN:BNC,ABS,DOVE GRAY	80009	205-0191-01
-16	131-3627-02			1	CONTACT,ELEC:SPRING LOADED,GOLD PLATED	TK2565	131-3627-02
-17	211-0001-00			1	SCREW,MACHINE:2-56 X 0.25,PNH,STL CD PL,POZ	93907	ORDER BY DESCRIP

**P6339A and replaceable parts and accessories (Cont.)**

Fig. & index number	Tektronix part number	Serial no. effective	Serial no. discont'd	Qty	Name & description	Mfr. code	Mfr. part number
-18	200-3018-00			1	COVER,CABLE NIP:COMP BOX	0J260	ORDER BY DESCRIPT
	071-0178-01			1	MANUAL,TECH:INSTRUCTIONS,P6339A	TK2548	071-0178-01
<b>OPTIONAL ACCESSORIES</b>							
17-8	SF201A			12	INSULATOR: ADAPTER, SMD, ORANGE, 50 MIL	80009	SF201A
	SF202A			12	INSULATOR: ADAPTER, SMD, BLUE, 0.65 mm/25 mil	80009	SF202A
	SF203A			12	INSULATOR: ADAPTER, SMD, RED, 0.50 mm/20 mil	80009	SF203A

**Manufacturers cross index**

<b>Mfr. code</b>	<b>Manufacturer</b>	<b>Address</b>	<b>City, state, zip code</b>
060D9	UNITREK CORPORATION	3000 COLUMBIA HOUSE BLVD, SUITE 1 20	VANCOUVER, WA 98661
0J260	COMTEK MANUFACTURING OF OREGON	P O BOX 4200 M/S 16-207	BEAVERTON, OR 970764200
80009	TEKTRONIX INC	14150 SW KARL BRAUN DR PO BOX 500	BEAVERTON, OR 97077-0001
93907	CAMCAR DIV OF TEXTRON INC	ATTN: ALICIA SANFORD 516 18TH AVE	ROCKFORD, IL 611045181
TK2548	XEROX CORPORATION	14181 SW MILLIKAN WAY	BEAVERTON, OR 97005
TK2565	VISION PLASTICS INC	26000 SW PARKWAY CENTER DRIVE	WILSONVILLE, OR 97070