

Service Manual



P6243
1 GHz 10X Active Probe
070-9409-03

Warning

The servicing instructions are for use by qualified personnel only. To avoid personal injury, do not perform any servicing unless you are qualified to do so. Refer to all safety summaries prior to performing service.

www.tektronix.com

Copyright © Tektronix, Inc. All rights reserved.

Tektronix products are covered by U.S. and foreign patents, issued and pending. Information in this publication supercedes that in all previously published material. Specifications and price change privileges reserved.

Tektronix, Inc., P.O. Box 500, Beaverton, OR 97077

TEKTRONIX, TEK, and TEKPROBE are registered trademarks of Tektronix, Inc.

WARRANTY

Tektronix warrants that the products that it manufactures and sells will be free from defects in materials and workmanship for a period of one (1) year from the date of shipment. If a product proves defective during this warranty period, Tektronix, at its option, either will repair the defective product without charge for parts and labor, or will provide a replacement in exchange for the defective product.

In order to obtain service under this warranty, Customer must notify Tektronix of the defect before the expiration of the warranty period and make suitable arrangements for the performance of service. Customer shall be responsible for packaging and shipping the defective product to the service center designated by Tektronix, with shipping charges prepaid. Tektronix shall pay for the return of the product to Customer if the shipment is to a location within the country in which the Tektronix service center is located. Customer shall be responsible for paying all shipping charges, duties, taxes, and any other charges for products returned to any other locations.

This warranty shall not apply to any defect, failure or damage caused by improper use or improper or inadequate maintenance and care. Tektronix shall not be obligated to furnish service under this warranty a) to repair damage resulting from attempts by personnel other than Tektronix representatives to install, repair or service the product; b) to repair damage resulting from improper use or connection to incompatible equipment; c) to repair any damage or malfunction caused by the use of non-Tektronix supplies; or d) to service a product that has been modified or integrated with other products when the effect of such modification or integration increases the time or difficulty of servicing the product.

THIS WARRANTY IS GIVEN BY TEKTRONIX IN LIEU OF ANY OTHER WARRANTIES, EXPRESS OR IMPLIED. TEKTRONIX AND ITS VENDORS DISCLAIM ANY IMPLIED WARRANTIES OF MERCHANTABILITY OR FITNESS FOR A PARTICULAR PURPOSE. TEKTRONIX' RESPONSIBILITY TO REPAIR OR REPLACE DEFECTIVE PRODUCTS IS THE SOLE AND EXCLUSIVE REMEDY PROVIDED TO THE CUSTOMER FOR BREACH OF THIS WARRANTY. TEKTRONIX AND ITS VENDORS WILL NOT BE LIABLE FOR ANY INDIRECT, SPECIAL, INCIDENTAL, OR CONSEQUENTIAL DAMAGES IRRESPECTIVE OF WHETHER TEKTRONIX OR THE VENDOR HAS ADVANCE NOTICE OF THE POSSIBILITY OF SUCH DAMAGES.



Table of Contents

General Safety Summary	iii
Specifications	1
Operating Basics	9
Maximum Non-destructive Input Voltage	9
Input Linear Dynamic Range	9
Theory of Operation	10
Probe Head and Cable Assembly	10
Compensation Box	11
Performance Verification	12
Equipment Required	12
Equipment Setup	12
Output Zero	13
DC Attenuation Accuracy	13
Maintenance	16
Replacing TEKPROBE™ Interface Pins	16
Removing and Replacing the Compensation Box Covers	17
Removing and Replacing the TEKPROBE™ Interface Collar	19
Inspection and Cleaning	20
Replacement Parts	20
Preparation for Shipment	20
Replaceable Parts	21

List of Figures

Figure 1: Typical Frequency Response	3
Figure 2: Typical Linearity Error vs. V_{IN}	4
Figure 3: Typical Input Impedance vs. Frequency	5
Figure 4: Typical Non-Destructive Peak Voltage Derating vs. Frequency	6
Figure 5: P6243 Simplified Schematic Diagram	10
Figure 6: TEKPROBE Interface	11
Figure 7: P6243 DC Attenuation Accuracy Setup	14
Figure 8: Replacing TEKPROBE Interface Pins	16
Figure 9: Removing the Compensation Box Covers	17
Figure 10: Replacing the Compensation Box Cover	18
Figure 11: Replacing the TEKPROBE Collar	19
Figure 12: P6243 Replaceable Parts	22
Figure 13: P6243 Standard Accessories	24
Figure 14: P6243 Optional Accessories	26

List of Tables

Table 1: Warranted Electrical Specifications	1
Table 2: Typical Electrical Characteristics	2
Table 3: Physical Characteristics	7
Table 4: Environmental Characteristics	7
Table 5: Certifications and Compliances	8
Table 6: Equipment Required for Performance Verification ..	12

General Safety Summary

Review the following safety precautions to avoid injury and prevent damage to this product or any products connected to it.

Only qualified personnel should perform service procedures.

Injury Precautions

Avoid Electric Overload. To avoid electric shock or fire hazard, do not apply a voltage to a terminal that is outside the range specified for that terminal.

Do Not Operate Without Covers. To avoid electric shock or fire hazard, do not operate this product with covers or panels removed.

Do Not Operate in Wet/Damp Conditions. To avoid electric shock, do not operate this product in wet or damp conditions.

Do Not Operate in an Explosive Atmosphere. To avoid injury or fire hazard, do not operate this product in an explosive atmosphere.

Product Damage Precautions

Use Proper Power Source. Do not operate this product from a power source that applies more than the voltage specified.

Do Not Operate With Suspected Failures. If you suspect there is damage to this product, have it inspected by qualified service personnel.

Do Not Immerse in Liquids. Clean the probe using only a damp cloth. The cloth must be dampened with either isopropyl alcohol or a mild detergent and water solution. Do not use any other chemicals or abrasives to clean the probe.

Safety Terms and Symbols

Terms in This Manual. These terms may appear in this manual:



WARNING. *Warning statements identify conditions or practices that could result in injury or loss of life.*



CAUTION. *Caution statements identify conditions or practices that could result in damage to this product or other property.*

Terms on the Product. These terms may appear on the product:

DANGER indicates an injury hazard immediately accessible as you read the marking.

WARNING indicates an injury hazard not immediately accessible as you read the marking.

CAUTION indicates a hazard to property including the product.

Symbols on the Product. These symbols may appear on the product:



DANGER
High Voltage



Protective Ground
(Earth) Terminal



ATTENTION
Refer to Manual



Double
Insulated

Specifications

The warranted specifications in Table 1 apply to a P6243 Active Probe when the probe and the host instrument are allowed to warm up for 20 minutes before measurements are taken. The warranted specifications that appear in boldface type are specifications checked in the *Performance Verification* section of the service manual.

The specifications in Tables 2 through 5 are provided as general information for your convenience.



CAUTION. Do not apply voltages beyond the non-destructive input voltage range to the probe. Damage to the probe or circuit under test may result. Refer to Figure 4 on page 6.

Table 1: Warranted Electrical Specifications

Analog Bandwidth (probe only) at +20 °C to +30 °C (+68 °F to +86 °F)	> 1.0 GHz
DC Attenuation Accuracy (probe only) at +20 °C to +30 °C (+68 °F to +86 °F)	10:1 ±2%
Output Zero at +20 °C to +30 °C (+68 °F to +86 °F)	±10 mV or less at output of probe ±100 mV or less displayed on screen with TEKPROBE interface
Rise Time (probe only) at +20 °C to +30 °C (+68 °F to +86 °F)	< 350 ps

Table 2: Typical Electrical Characteristics

Frequency Response (probe only)	See Figure 1
Linear Input Dynamic Range	- 8 V to + 8 V. (Equivalent to - 0.8 V to + 0.8 V at the output of the probe)
Linearity	± 4% or less of dynamic range
Linearity Error vs. V_{IN}	See Figure 2
Input Resistance	1 M Ω at DC. (See Figure 3)
Input Capacitance	< 1.0 pF
Non-Destructive Input Voltage Range	- 15 V to + 15 V (DC + peak AC) (See Figure 4 on page 6)
DC Offset Drift	100 μ V/ $^{\circ}$ C or less at output of probe 1 mV/ $^{\circ}$ C or less displayed on screen with TEKPROBE interface
Delay Time	5.3 ns \pm 0.2 ns

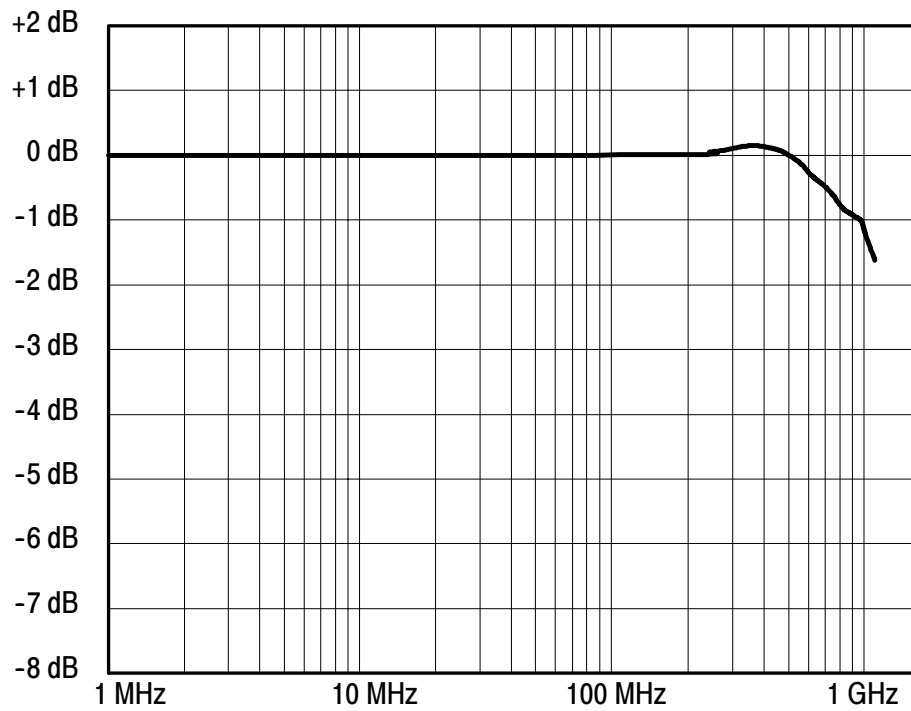

Figure 1: Typical Frequency Response

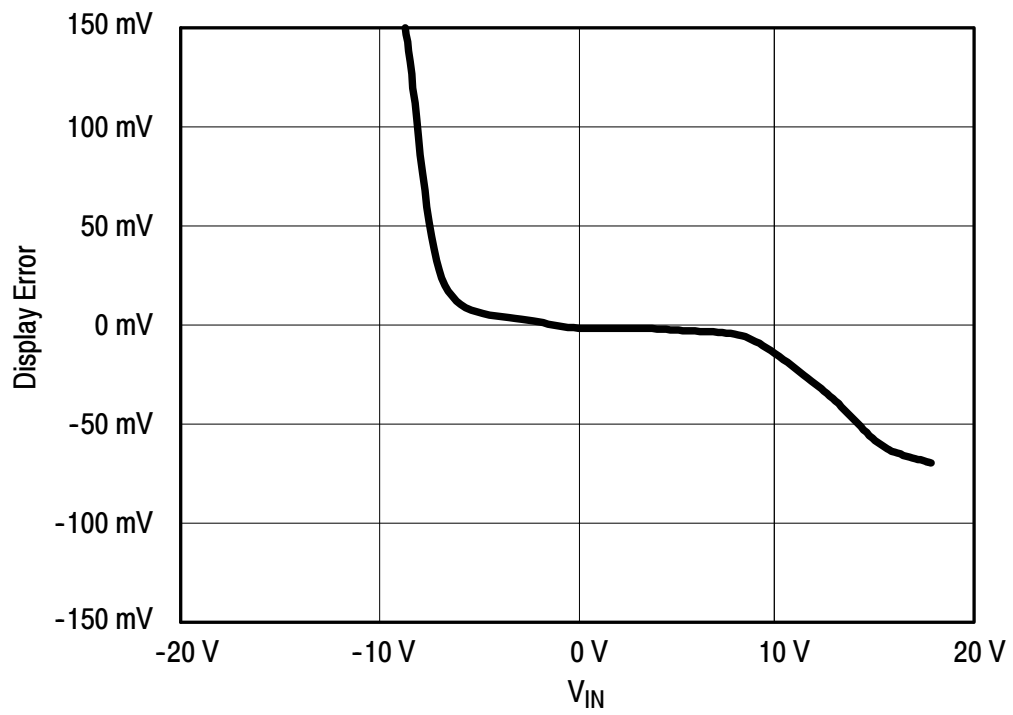

Figure 2: Typical Linearity Error vs. V_{IN}

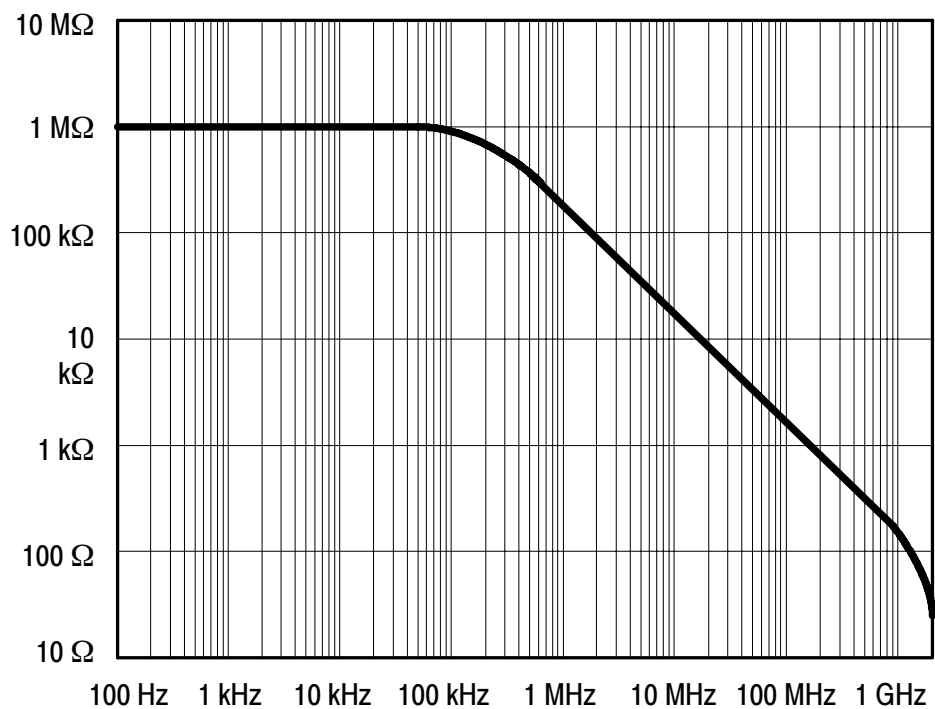

Figure 3: Typical Input Impedance vs. Frequency

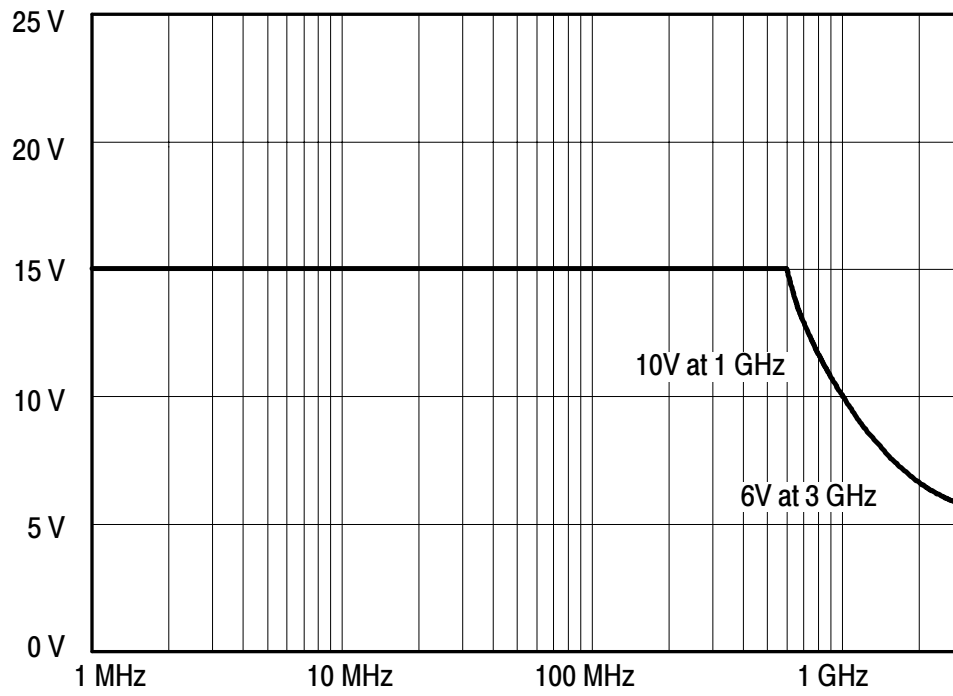

Figure 4: Typical Non-Destructive Peak Voltage Derating vs. Frequency

Table 3: Physical Characteristics

Net Weight	63.8 g (2.25 ounces)
Cable Length	1.3 meter (4.3 ft)

Table 4: Environmental Characteristics

Operating Temperature	0 °C to +50 °C (+32 °F to +122 °F) The environmental exposure is the procedure stated in Tektronix Design Standard 062-2847-00 for Class 5 equipment
Non-operating Temperature	- 40 °C to + 71 °C (- 40 °F to + 160 °F) The environmental exposure is the procedure stated in Tektronix Design Standard 062-2847-00 for Class 5 equipment
Humidity	The environmental exposure is the procedure stated in Tektronix Design Standard 062-2847-00 for Class 5 equipment
Packaged Product Vibration and Shock	The packaged product qualifies under the Distribution Cycle 1 Assurance Level II for packaged products 0 - 20 lbs. Test 2 for Warehouse and Vehicle Stacking (Compression) is omitted Tektronix standard 062-2858-00, Rev. B, Class 5
Altitude	Operating: 4,572 m (15,000 ft) Non-Operating: 15,240 m (50,000 ft)

Table 5: Certifications and Compliances

EC Declaration of Conformity	Meets the intent of Directive 89/336/EEC for Electromagnetic Compatibility. Compliance was demonstrated to the following specifications as listed in the official Journal of the European Communities:										
	<table> <tr> <td data-bbox="553 562 841 594">EN 50081 -1 Emissions:</td> <td></td> </tr> <tr> <td data-bbox="678 600 797 632">EN 55022</td> <td data-bbox="922 600 1187 669">Class B: Radiated and Conducted Emissions</td> </tr> <tr> <td data-bbox="678 674 829 705">EN 60555-2</td> <td data-bbox="922 674 1133 705">Power Harmonics</td> </tr> </table>	EN 50081 -1 Emissions:		EN 55022	Class B: Radiated and Conducted Emissions	EN 60555-2	Power Harmonics				
EN 50081 -1 Emissions:											
EN 55022	Class B: Radiated and Conducted Emissions										
EN 60555-2	Power Harmonics										
	<table> <tr> <td data-bbox="553 732 824 764">EN 50082 -1 Immunity:</td> <td></td> </tr> <tr> <td data-bbox="678 770 805 802">IEC 801 -2</td> <td data-bbox="922 770 1195 802">Electrostatic Discharge</td> </tr> <tr> <td data-bbox="678 808 805 840">IEC 801 -3</td> <td data-bbox="922 808 1073 840">RF Radiated</td> </tr> <tr> <td data-bbox="678 846 805 877">IEC 801 -4</td> <td data-bbox="922 846 1105 877">Fast Transients</td> </tr> <tr> <td data-bbox="678 884 805 915">IEC 801 -5</td> <td data-bbox="922 884 997 915">Surge</td> </tr> </table>	EN 50082 -1 Immunity:		IEC 801 -2	Electrostatic Discharge	IEC 801 -3	RF Radiated	IEC 801 -4	Fast Transients	IEC 801 -5	Surge
EN 50082 -1 Immunity:											
IEC 801 -2	Electrostatic Discharge										
IEC 801 -3	RF Radiated										
IEC 801 -4	Fast Transients										
IEC 801 -5	Surge										
FCC Compliance	Emissions comply with FCC Code of Federal Regulations 47 CFR, Part 15, Subpart B, Class A										

Operating Basics

Please follow these operating guidelines to get optimum performance from your P6243 Active Probe.

Maximum Non-destructive Input Voltage

The P6243 Active Probe is electrically protected against static voltage; however, applying voltages above its design limits may damage the probe tip amplifier. Please refer to the *Specifications* section of this manual for the maximum non-destructive input voltage and frequency derating information.

Input Linear Dynamic Range

The probe head amplifier used by the P6243 Active Probe has a limited linear operating range. To keep the input linearity error less than 4% you must limit the signal input voltage to ± 8 V (DC + peak AC).

NOTE. *The probe can tolerate input voltages of ± 15 V without damage; however, the linearity error specification does not apply to input voltages exceeding ± 8 V (DC + peak AC).*

Theory of Operation

There are no user replaceable parts within the probe or the compensation box; however, this theory of operation is provided to assist you in isolating failures to either the probe or the host oscilloscope. Refer to Figure 5 for a simplified schematic of the probe.

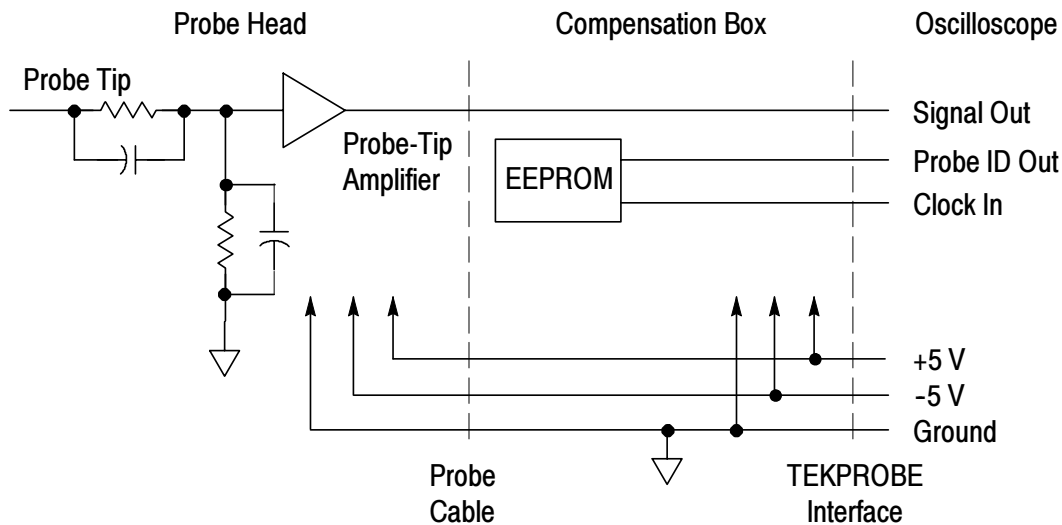

Figure 5: P6243 Simplified Schematic Diagram

Probe Head and Cable Assembly

The probe head assembly contains an active amplifier circuit that buffers and amplifies the input signal. The amplifier receives power from the compensation box assembly via the cable assembly. All signal amplification and buffering is performed in the probe head assembly. No further amplification takes place in the compensation box.

Compensation Box

The compensation box contains the following circuits:

- Probe identification EEPROM
- TEKPROBE interface

Probe Identification EEPROM

The probe identification EEPROM is used to configure the oscilloscope to the probe. The EEPROM receives a clock input from the oscilloscope, and information about the probe is passed to the oscilloscope.

TEKPROBE™ Interface

The TEKPROBE interface provides a communication path between the probe and the oscilloscope. Contact pins provide power, signal, and data transfer for the probe identification EEPROM.

Figure 6 shows the TEKPROBE interface pin functions. Refer to the service documentation of your oscilloscope for more detailed specifications.

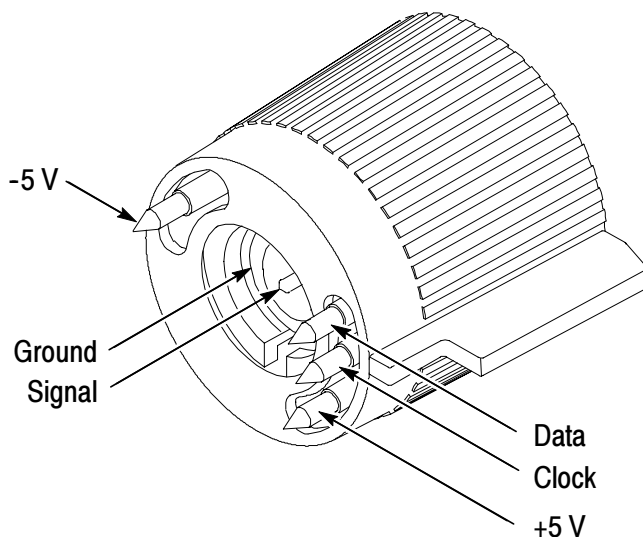

Figure 6: TEKPROBE Interface

Performance Verification

This section contains the procedures for verifying the performance of the P6243 Active Probe.

Equipment Required

Table 6: Equipment Required for Performance Verification

Item Description	Performance Requirement	Recommended Example
Oscilloscope	TEKPROBE interface	Tektronix TDS 744A
TEKPROBE Power Supply		Tektronix 1103
DC Power Supply	10.00 \pm .01 VDC at 1 mA	Tektronix PS281
DC Voltmeter	0.5% accuracy at 2 VDC	Tektronix CDM250
Feedthrough Termination	50 Ω \pm 0.50 Ω	011-0129-00
BNC to BNC coaxial cable	50 Ω coaxial cable	012-1342-00
BNC to Banana adapter	BNC Female to Dual Banana	103-0090-00

Equipment Setup

1. Connect the probe to the oscilloscope.
2. Connect a Y-lead adapter with KlipChip adapters attached to the P6243 probe head.
3. Turn on the oscilloscope and enable the channel.
4. Turn on the power supply and set to +2.00 VDC.
5. Turn on the 1103 power supply.
6. Allow 30 minutes for the equipment to warm up.

NOTE. *If your oscilloscope has a probe calibration routine, run it before making any of the following checks. Refer to the instruction manual of the oscilloscope for more information.*

Output Zero

Use this procedure to verify the output zero of the probe is within specified limits.

1. Ground the probe tip by connecting the probe tip to the probe ground socket. (Connecting the two KlipChip adapters together is recommended.)
2. Set the oscilloscope input coupling channel to ground and adjust the vertical position to center screen.
3. Set the oscilloscope input coupling channel to DC and set the vertical scale to 100 mV/division.
4. Measure the displayed DC level.

The displayed DC level should be 0.00 V \pm 100 mV. (\pm 10 mV when measured directly without the probe attenuation factor.)

DC Attenuation Accuracy

Use this procedure to verify the DC attenuation accuracy of the probe. Before beginning, read the procedure through completely.

1. Connect the test equipment as shown in Figure 7.
2. Attach the probe to a TEKPROBE interface on the 1103 power supply.
3. Set the 1103 offset **VAR/0V** to **0V**.
4. Set the multimeter to read DC volts.

5. Connect the probe tip and ground to the power supply using the Y-lead and KlipChip adapters.

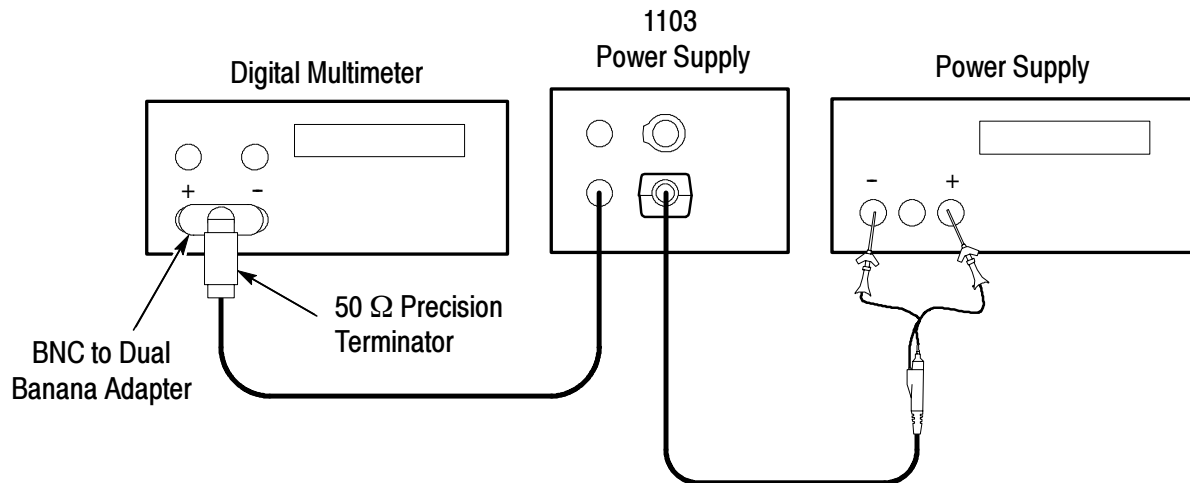

Figure 7: P6243 DC Attenuation Accuracy Setup

6. Set the power supply to +2.000 V. (This setting will be referred to later on as V_{max}).
7. Record the value measured by the multimeter as M1. (With the 10X attenuation of the probe, the voltage measured will be about +0.200 V.)
8. Set the power supply to -2.000 V. (This setting will be referred to later on as V_{min}).
9. Record the value measured by the multimeter as M2. (With the 10X attenuation of the probe, the voltage measured will be about -0.200 V.)

NOTE. *If you are unable to set the power supply precisely, record the settings displayed on the power supply and determine the absolute difference. $|V_{max} - V_{min}| = \text{difference}$.*

Divide the difference by 10 to account for the ideal attenuation factor of the probe. For example, 0.42 is the difference between +2.200 and -2.000, divided by 10. Use this calculated value in place of the denominator of the formula that follows.

10. Determine the percent error by using the formula below:

$$\%Error = \left[\frac{M1 - M2}{0.4} - 1 \right] \times 100\%$$

The calculated error should be $\leq 2\%$.

NOTE. *An unacceptable error value may result if a low tolerance termination is substituted for the recommended termination.*

Maintenance

This section details the maintenance, repair, and troubleshooting procedures for the P6243.

Replacing TEKPROBE™ Interface Pins

TEKPROBE interface pins can stick and fail to make contact after time. Periodically check to see that each of the interface pins move freely and fully extends out of the interface. If any pin fails to move freely and fully extend, it should be replaced.

To remove a TEKPROBE interface pin, firmly grasp the pointed tip with pliers and pull the pin out of the connector. See Figure 8.

No tools are required to install a replacement pin. Insert a new pin into the connector socket as far as possible using finger pressure. If necessary, seat the pin into the connector by pressing the tip gently but firmly against a hard surface, such as a wood block or table top.

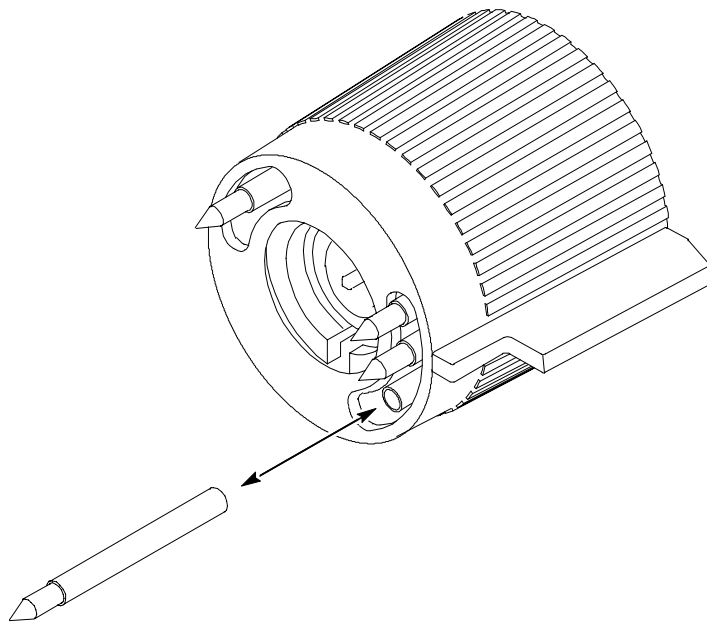

Figure 8: Replacing TEKPROBE Interface Pins

Removing and Replacing the Compensation Box Covers

Follow these steps to open the compensation box.

1. Press the optional release tool pins into the compensation box cover catches and gently lift the cover off a small distance. Refer to Figure 9.
2. Hold the open edge apart, and use the tool to open the other side of the compensation box.
3. With both sides of the box open, gently separate the two halves of the compensation box.

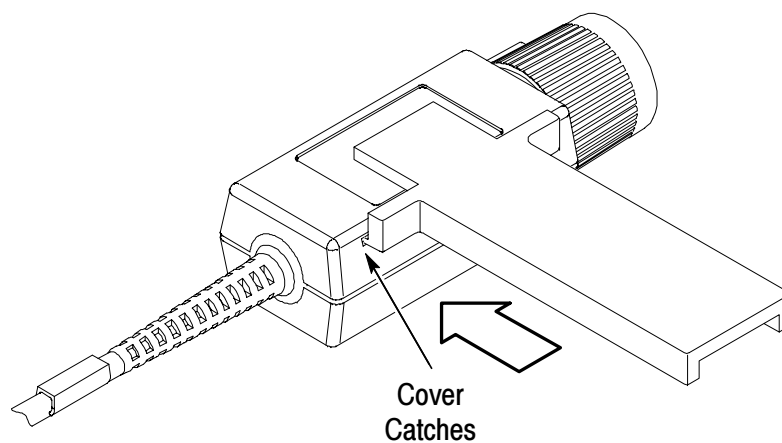

Figure 9: Removing the Compensation Box Covers

To replace the covers, follow these steps:

1. Align the TEKPROBE interface and the strain relief notches with the tabs on the cover. Refer to Figure 10.
2. Press the cover catches in so that the cover can be lowered.
3. Slide the tab into the notch.
4. Firmly press the pieces together until the cover catches snap into place.

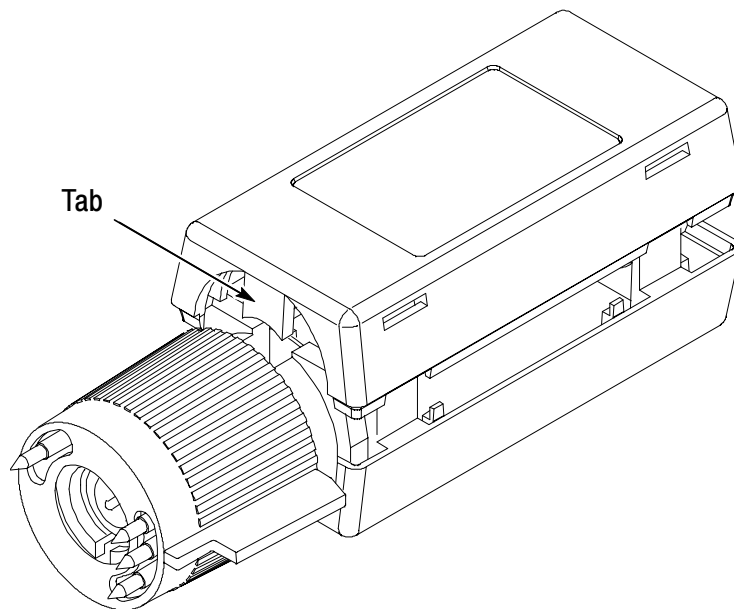

Figure 10: Replacing the Compensation Box Cover

Removing and Replacing the TEKPROBE™ Interface Collar

To remove the TEKPROBE interface collar, firmly grasp the compensation box body with one hand, and the TEKPROBE interface collar with the other hand. Firmly pull the interface collar off.

To replace the collar, first note the pin configuration on the compensation box, and their holes in the interface collar. The group of three pins fit through the smaller of the two holes in the interface collar. See Figure 11.

Align the tab to the slot and gently press the two pieces together. See Figure 11.

Once installed, the TEKPROBE collar should rotate freely to lock and unlock.

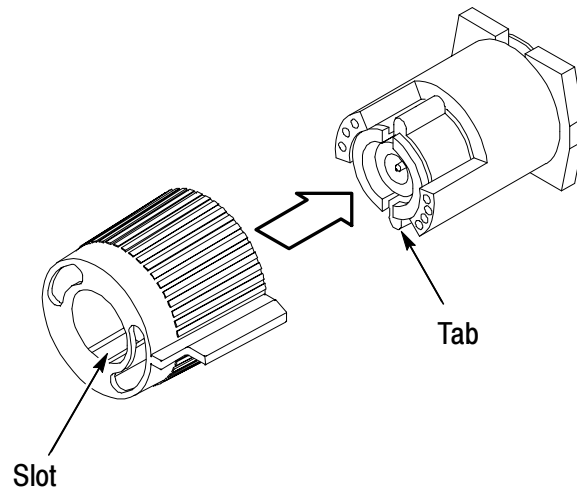

Figure 11: Replacing the TEKPROBE Collar

Inspection and Cleaning

To prevent damage to probe materials, avoid using chemicals that contain benzine, benzene, toluene, xylene, acetone, or similar solvents.

Do not immerse the probe or use abrasive cleaners.

Dirt may be removed with a soft cloth dampened with a mild detergent and water solution, or isopropyl alcohol.

Replacement Parts

Refer to the Replaceable Parts section for a list of customer replacement parts. Due to the sophisticated design of the P6243, there are no user replaceable parts within the probe.

Preparation for Shipment

If the original packaging is unfit for use or not available, use the following packaging guidelines:

1. Use a corrugated cardboard shipping carton having inside dimensions at least one inch greater than the probe dimensions. The box should have a carton test strength of at least 200 pounds.
2. Put the probe into a plastic bag or wrap to protect it from dampness.
3. Place the probe into the box and stabilize it with light packing material.
4. Seal the carton with shipping tape.



Replaceable Parts

This section contains a list of the replaceable parts for the P6243 Active Probe. Use this list to identify and order replacement parts.

Parts Ordering Information

Replacement parts are available from or through your local Tektronix, Inc. service center or representative.

Changes to Tektronix instruments are sometimes made to accommodate improved components as they become available and to give you the benefit of the latest circuit improvements. Therefore, when ordering parts, it is important to include the following information in your order:

- Part number
- Instrument type or model number
- Instrument serial number
- Instrument modification number, if applicable

If a part you order has been replaced with a different or improved part, your local Tektronix service center or representative will contact you concerning any change in the part number.

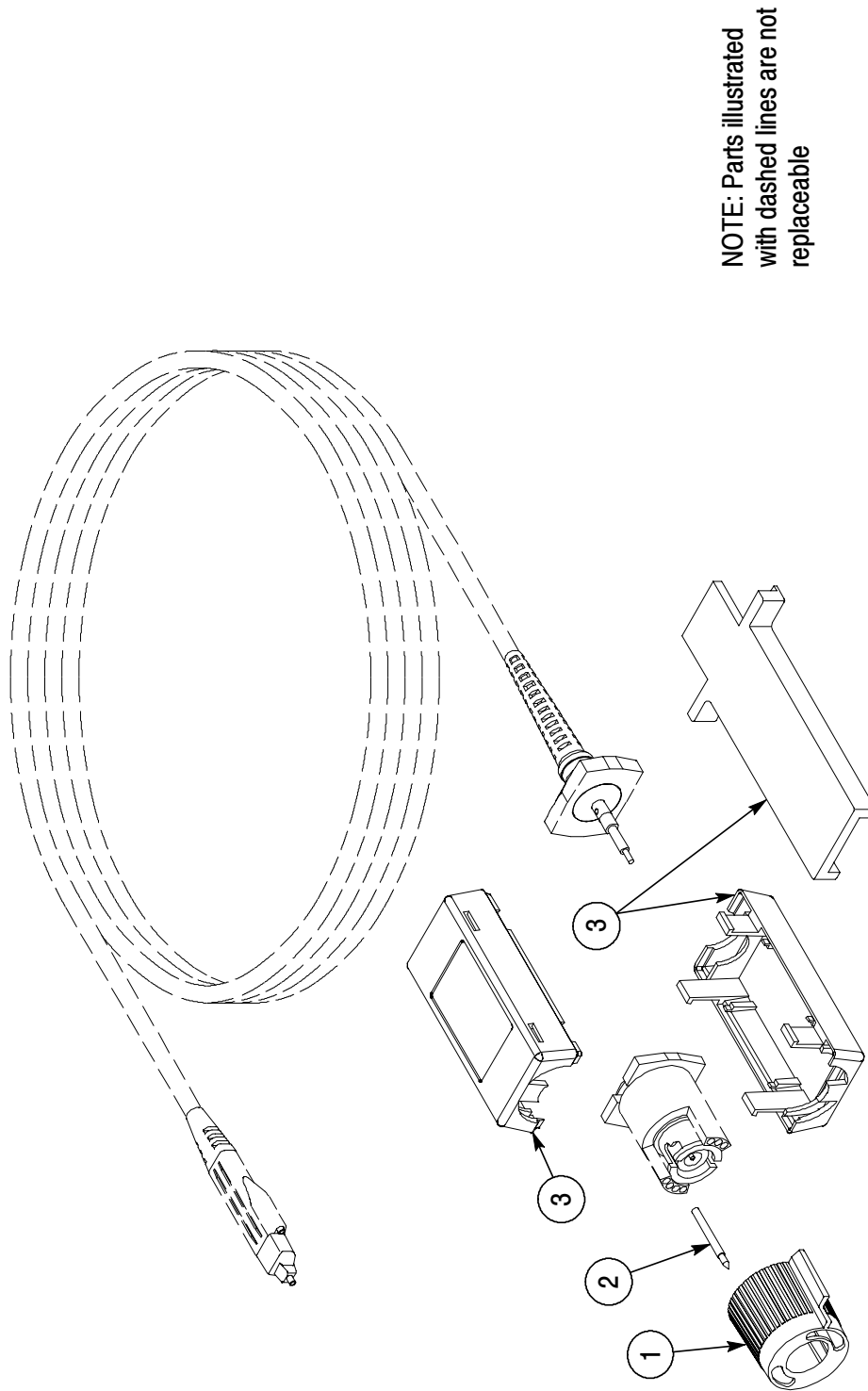

Figure 12: P6243 Replaceable Parts

Fig. & Index No.	Tektronix Part No.	Serial No. Effective	Dscont	Qty	12345 Name & Description	Mfr. Code	Mfr. Part No.
12	P6243			1	PROBE, FET ACT:> 1.5 GHZ, 10X,< 1PF, TDS SERIES	80009	P6243
-1	205-0191-XX			1	SHELL, ELEC CONN: BNC, ABS, DOVE GRAY	80009	205-0191-XX
-2	131-3627-01			1	CONTACT, ELEC: GOLD PLATED TIP	80009	131-3627-01
-3	200-4276-00			1	COVER, COMP BOX: TOP AND BOTTOM, W/LABELS & RELEASE TOOLS	80009	200-4276-00

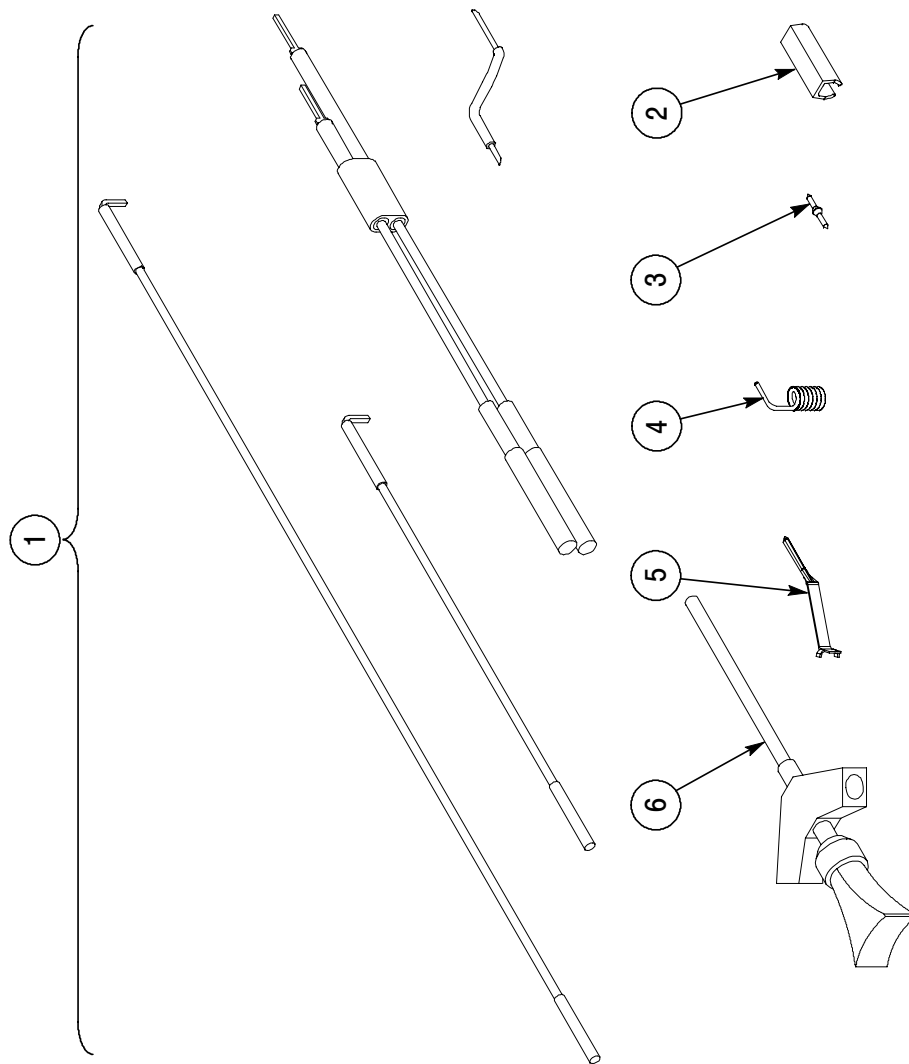

Figure 13: P6243 Standard Accessories

Fig. & Index No.	Tektronix Part No.	Serial No. Effective Dscont	Qty	12345 Name & Description	Mfr. Code	Mfr. Part No.
13				STANDARD ACCESSORIES		
-1	196-3425-00		1	LEAD,SET:ONE 3.0 L; ONE 6.0 L;STRD,22 AWG & ONE 3.0 L BLACK & WHITE 22 AWG,JACK TIP,TERM CONN MALE PIN;TWO Z-LEAD	80009	196-3425-00
-2	016-1315-00		1	MARKER KIT,ID:CABLE MARKER BAND,2 EACH, VARIOUS COLORS	80009	016-1315-00
-3	131-5638-11		1	PROBE,TIP:PACKAGE OF 10	80009	131-5638-11
-4	214-4227-00		1	SPRING ADAPTER:RIGHT ANGLE	80009	214-4227-00
-5	131-5777-00		1	CONN,CONTACT	80009	131-5777-00
-6	206-0364-XX		2	TIP,PROBE:MICROCKT TEST	80009	206-0364-XX
	070-9408-XX		1	MANUAL,TECH:INSTRUCTION,ENGLISH,DP,P6243	TK2548	070-9408-XX
	070-9409-XX		1	MANUAL,TECH:SERVICE,DP,P6243	TK2548	070-9409-XX
	070-9410-XX		1	MANUAL,TECH:INSTRUCTION,FRENCH,DP,P6243	TK2548	070-9410-XX
	070-9411-XX		1	MANUAL,TECH:INSTRUCTION,GERMAN,DP,P6243	TK2548	070-9411-XX
	070-9412-XX		1	MANUAL,TECH:INSTRUCTION,SPANISH,DP,P6243	TK2548	070-9412-XX

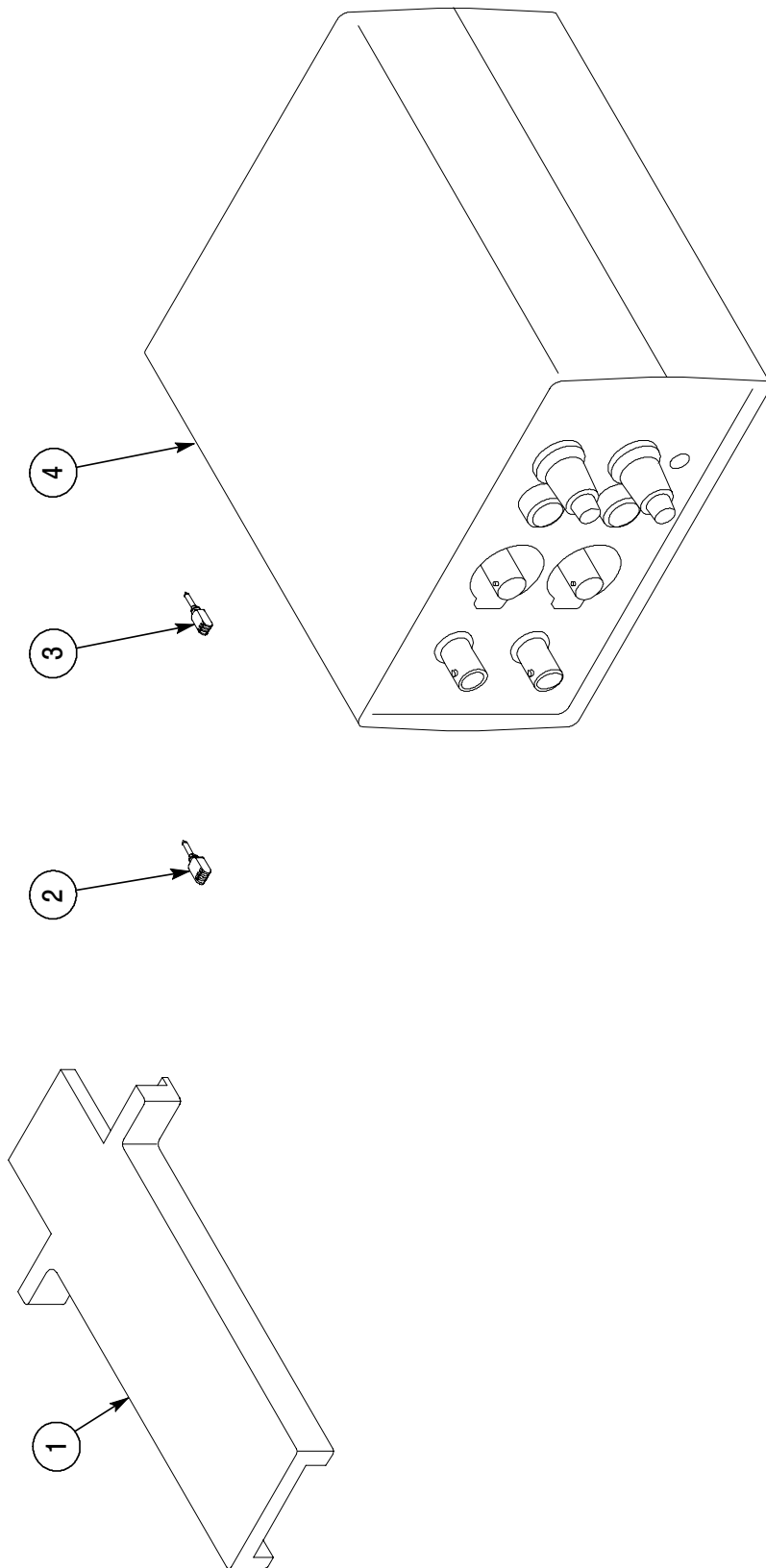

Figure 14: P6243 Optional Accessories

Fig. & Index No.	Tektronix Part No.	Serial No. Effective	Discont	Qty	12345 Name & Description	Mfr. Code	Mfr. Part No.
OPTIONAL ACCESSORIES							
14-1	003-1383-00			1	RLSE TOOL, COVER:COMP BOX, POLYCARBONATE	80009	003-1383-00
-2	SF503			1	ADAPTER, SUREFOOT:0.5 MM EIAJ, PKG OF 12	80009	SF503
-3	SF502			1	ADAPTER, SUREFOOT:25 MIL JEDEC, PKG OF 12	80009	SF502
-4	1103			1	TEKPROBE IF PS:W/OFFSET 2 CONN	80009	1103
13-4	SMG50			1	PKG OF 20	80009	SMG50

CROSS INDEX - MFR. CODE NUMBER TO MANUFACTURER

Mfr. Code	Manufacturer	Address	City, State, Zip Code
TK2548	XEROX BUSINESS SERVICES DIV OF XEROX CORPORATION	14181 SW MILLIKAN WAY	BEAVERTON OR 97077
80009	TEKTRONIX INC	14150 SW KARL BRAUN DR PO BOX 500	BEAVERTON OR 97077-0001

