

Instruction Manual



P6106A **250 MHz 10X Passive Probe** **070-5517-03**

Warning

The servicing instructions are for use by qualified personnel only. To avoid personal injury, do not perform any servicing unless you are qualified to do so. Refer to all safety summaries prior to performing service.

www.tektronix.com



070-551703

Copyright © Tektronix, Inc. All rights reserved.

Tektronix products are covered by U.S. and foreign patents, issued and pending. Information in this publication supercedes that in all previously published material. Specifications and price change privileges reserved.

Tektronix, Inc., P.O. Box 500, Beaverton, OR 97077

TEKTRONIX and TEK are registered trademarks of Tektronix, Inc.

WARRANTY

Tektronix warrants that the products that it manufactures and sells will be free from defects in materials and workmanship for a period of one (1) year from the date of purchase from an authorized Tektronix distributor. If any such product proves defective during this warranty period, Tektronix, at its option, either will repair the defective product without charge for parts and labor, or will provide a replacement in exchange for the defective product. Batteries are excluded from this warranty.

In order to obtain service under this warranty, Customer must notify Tektronix of the defect before the expiration of the warranty period and make suitable arrangements for the performance of service. Customer shall be responsible for packaging and shipping the defective product to the service center designated by Tektronix, shipping charges prepaid, and with a copy of customer proof of purchase. Tektronix shall pay for the return of the product to Customer if the shipment is to a location within the country in which the Tektronix service center is located. Customer shall be responsible for paying all shipping charges, duties, taxes, and any other charges for products returned to any other locations.

This warranty shall not apply to any defect, failure or damage caused by improper use or improper or inadequate maintenance and care. Tektronix shall not be obligated to furnish service under this warranty a) to repair damage resulting from attempts by personnel other than Tektronix representatives to install, repair or service the product; b) to repair damage resulting from improper use or connection to incompatible equipment; c) to repair any damage or malfunction caused by the use of non-Tektronix supplies; or d) to service a product that has been modified or integrated with other products when the effect of such modification or integration increases the time or difficulty of servicing the product.

THIS WARRANTY IS GIVEN BY TEKTRONIX WITH RESPECT TO THE LISTED PRODUCTS IN LIEU OF ANY OTHER WARRANTIES, EXPRESS OR IMPLIED. TEKTRONIX AND ITS VENDORS DISCLAIM ANY IMPLIED WARRANTIES OF MERCHANTABILITY OR FITNESS FOR A PARTICULAR PURPOSE. TEKTRONIX' RESPONSIBILITY TO REPAIR OR REPLACE DEFECTIVE PRODUCTS IS THE SOLE AND EXCLUSIVE REMEDY PROVIDED TO THE CUSTOMER FOR BREACH OF THIS WARRANTY. TEKTRONIX AND ITS VENDORS WILL NOT BE LIABLE FOR ANY INDIRECT, SPECIAL, INCIDENTAL, OR CONSEQUENTIAL DAMAGES IRRESPECTIVE OF WHETHER TEKTRONIX OR THE VENDOR HAS ADVANCE NOTICE OF THE POSSIBILITY OF SUCH DAMAGES.

Contacting Tektronix

Product support	<p>For questions about using Tektronix measurement products, call toll free in North America: 1-800-833-9200 6:00 a.m. – 5:00 p.m. Pacific time</p> <p>Or contact us by e-mail: tm_app_supp@tek.com</p> <p>For product support outside of North America, contact your local Tektronix distributor or sales office.</p>
Service support	<p>Tektronix offers extended warranty and calibration programs as options on many products. Contact your local Tektronix distributor or sales office.</p> <p>For a listing of worldwide service centers, visit our web site.</p>
For other information	<p>In North America: 1-800-833-9200 An operator can direct your call.</p>
To write us	<p>Tektronix, Inc. P.O. Box 500 Beaverton, OR 97077-1000 USA</p>
Web site	<p>www.tektronix.com</p>

General Safety Summary

Review the following safety precautions to avoid injury and prevent damage to this product or any products connected to it. To avoid potential hazards, use this product only as specified.

Only qualified personnel should perform service procedures.

To Avoid Fire or Personal Injury

Connect and Disconnect Properly. Do not connect or disconnect probes or test leads while they are connected to a voltage source.

Observe All Terminal Ratings. To avoid fire or shock hazard, observe all ratings and markings on the product. Consult the product manual for further ratings information before making connections to the product.

The common terminal is at ground potential. Do not connect the common terminal to elevated voltages.

Do not apply a potential to any terminal, including the common terminal, that exceeds the maximum rating of that terminal.

Do Not Operate With Suspected Failures. If you suspect there is damage to this product, have it inspected by qualified service personnel.

Do Not Operate in Wet/Damp Conditions.

Do Not Operate in an Explosive Atmosphere.

Keep Product Surfaces Clean and Dry.

Symbols and Terms

Terms in this Manual. The following terms may appear in this manual:



WARNING. *Warning statements identify conditions or practices that could result in injury or loss of life.*



Service Safety Summary

Only qualified personnel should perform service procedures. Read this *Service Safety Summary* and the *General Safety Summary* before performing any service procedures.

Do Not Service Alone. Do not perform internal service or adjustments to this product unless another person capable of rendering first aid and resuscitation is present.

P6106A Passive Probe

Thank you for choosing a Tektronix passive probe. This manual provides the information necessary to begin making measurements with your P6106A probe. Topics are presented in the following order:

- **Description**—A description of the probe and its options.
- **Safety**—A review of important safety considerations.
- **Installation**—Information about attaching the probe to an instrument, and attaching accessories to the probe.
- **Operating Considerations**—Information about using the probe.
- **Maintenance**—Instructions for cleaning the probe and replacing major assemblies.
- **Replaceable Parts**—An exploded view of the probe and a list of replaceable parts.

Description

The P6106A is a miniature, 10X-attenuating passive probe that is compatible with general purpose oscilloscopes having a 1 M Ω input impedance.

The P6106A is compatible with Tektronix oscilloscopes that automatically detect and display the attenuation factor of the attached probe.

The P6106A has a ground-reference push button that momentarily grounds the probe output. This feature allows you to quickly identify the oscilloscope display associated with one of several attached probes as well as making ground-referenced measurements easier.

The P6106A is available with the following cable lengths:

Standard	2 meters
Option 01	1 meter

Each probe option is fully compatible with Tektronix accessories for miniature probes.

Installation

This section describes both attaching the probe to an oscilloscope and using the standard accessories with the probe.

Attaching the Probe to an Oscilloscope

The probe uses a BNC connector to attach to an oscilloscope input connector. To ensure optimum performance from your probe/oscilloscope measurement system, verify that the probe and oscilloscope are appropriately matched. The oscilloscope input impedance should be 1 M Ω . The oscilloscope input capacitance should be between 15 and 35 pF. Refer to “Compensation Range” in Table 1 on page 8 for more information.

Using the Standard Accessories

Your P6106A is shipped with the following accessories:

- **This instruction manual**—Read these instructions to familiarize yourself with the features, specifications, and operation of the P6106A passive probe.
- **Accessory pouch**—(not shown) Use the accessory pouch to store the probe and its accessories when they are not being used.
- **Adjustment tool**—Use the insulated adjustment tool to adjust the low frequency trimmer in the probe compensation box.
- **IC protector tip**—Use the IC protector tip to keep the metal sleeve of the probe tip from accidentally shorting together the leads of an IC or other circuit element. The shape of the protector tip helps you place the tip accurately onto an IC lead.
- **Retractable hook tip**—Use the retractable hook tip to make hands-free measurements. The hook tip attaches to components having leads, such as resistors, capacitors, and discrete semiconductors. You can also grip stripped wire, jumpers, busses, and test pins with the retractable hook.

For maximum flexibility with the hook tip, use the twelve-inch ground lead. For precise measurements at high frequency, however, long ground leads may have too much inductance. In these cases you should use the five-inch ground lead.

To remove the hook tip, simply pull it off the probe. Reinstall it by pushing it firmly onto the probe tip.

- **Ground cover**—Use the protective ground cover to keep the metal sleeve of the probe tip from accidentally shorting circuit elements to ground. Remove the ground cover before installing the retractable hook tip.
- **Marker rings**—Use the marker rings to help you keep track of individual probes and signal sources when you have a complicated test setup. Use the marker rings whenever you want to identify a particular probe for any

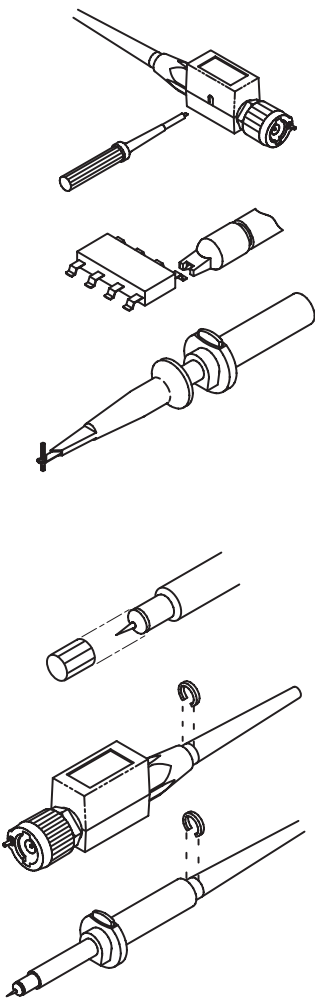

reason. To make probe identification easy, clip matching colored rings onto the probe cable and tip as shown.

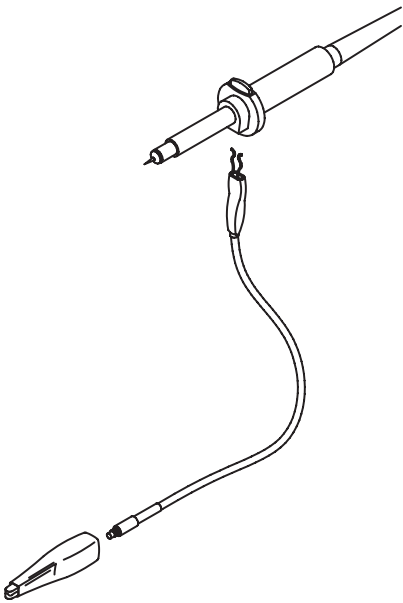

- **Three-inch ground lead**—Use the Three-inch ground lead to establish a ground reference for your measurements. Whenever freedom from aberrations and amplitude accuracy are more important than probe reach and flexibility, use the shortest ground lead possible.

To attach the ground lead to the probe, insert the spring clip into the receptacle as shown. If the alligator clip is not attached, screw it onto the threaded end of the lead.

- **Five-inch ground lead**—Use the long ground lead when a long reach is important and high-frequency information is not. Because of the high inductance associated with long ground leads, you should not use them for precise measurements above approximately 30 MHz (or for pulses with rise times less than about 11 ns). Long ground leads are ideal for quick troubleshooting when you are looking for the presence or absence of a signal and are not concerned with the precision of the measurement.

The five-inch ground lead attaches in the same manner as the three-inch lead.

- **Alligator clip**—Use the alligator clip with one of the ground leads. Screw the alligator clip onto the threaded end of a ground lead.

Operating Considerations

This information in this section will help you make the most effective use of your P6106A probe.

Features and Controls

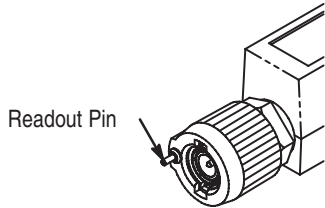

- Readout pin**—The BNC connector of the probe includes a spring-loaded pin that connects to a mating contact ring on certain oscilloscopes. These oscilloscopes recognize the attenuation factor of the probe and automatically correct the oscilloscope indication of scale factor. You can determine if your oscilloscope supports this feature by watching the oscilloscope vertical scale factor readout when attaching the probe. If the displayed scale changes by a factor of 10—for instance, from 10 mV to 100 mV—your oscilloscope supports this feature.

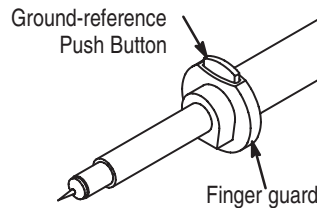

- Ground-reference push button**—Press the ground-reference push button to momentarily short the signal output of the probe to ground (the signal under test is not affected). Using the ground-reference push button allows you to quickly note or verify the ground reference of a DC measurement. If your oscilloscope is displaying several traces, pressing the ground-reference push button also helps you to identify which trace is associated with the probe.



WARNING. To avoid electric shock when using the probe, keep fingers behind the guard on the probe body.

Ground Lead Inductance

In order for an amplitude measurement to be meaningful, you must give the measurement some point of reference. The ground lead provides access to this ground reference.

When you subsequently touch your probe tip to a circuit element, you introduce additional resistance, capacitance, and inductance into the circuit (Figure 1).

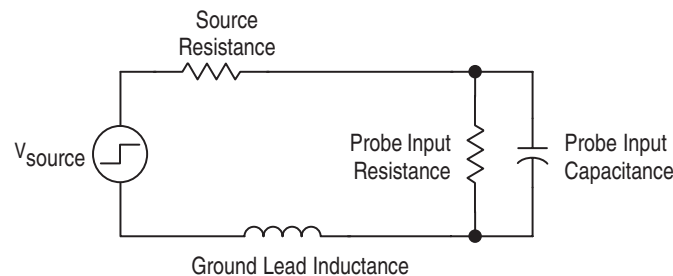

Figure 1: A Probe Adds Resistance, Capacitance, and Inductance

A passive probe is capacitive for high-frequency signals. For most circuits, the high input resistance of a passive probe has a negligible effect on the signal. The series inductances represented by the probe tip and ground lead, however, can result in a parasitic resonant circuit that may “ring” within the bandwidth of the oscilloscope. If the ringing is at a frequency within the oscilloscope bandwidth, the ringing appears on the oscilloscope display as a distortion of the true waveform. Figure 2 shows the effect on the same signal through the same probe with different ground leads.

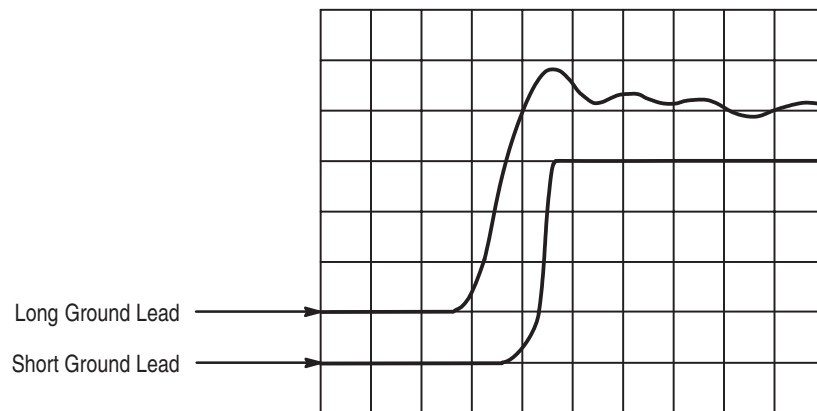

Figure 2: Signal Distortion Introduced by Ground Lead Inductance

Reducing the ground lead inductance will raise the resonant frequency. Ideally, the inductance is low enough that the resulting frequency is above the frequency at which you want to take measurements. To maintain the best signal integrity, use the shortest possible ground lead and signal input path.

Low-Frequency Probe Compensation

Passive probes require compensation to ensure maximum distortion-free output and to avoid high-frequency amplitude errors.

Because of variations in oscilloscope input characteristics, probe low-frequency (LF) compensation may need adjustment after moving the probe from one oscilloscope to another. Verify the compensation before making critical rise time or amplitude measurements.

If a 1-kHz calibrated square wave displayed at 1 ms/division shows significant differences between the leading and trailing edges (see figures at left), perform the following steps to optimize low-frequency compensation.

1. Connect the probe tip to a calibration signal. Most oscilloscopes have a front panel test point for this purpose; if yours does not, use a signal generator that produces a well-formed square wave at approximately 1 kHz.



Undercompensated

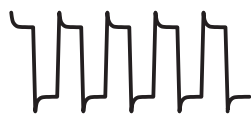

Overcompensated



Properly Compensated

2. Press **AUTOSET** (on many Tektronix oscilloscopes) or otherwise adjust the oscilloscope so that it displays a waveform similar to those shown in this section.

Optional: If your oscilloscope has a limited-bandwidth mode, enable it. Filtering out high-frequency noise will make the adjustment easier to perform.

3. Adjust the trimmer in the probe (refer to Figure 3) until you see a flat-top square wave on the display.

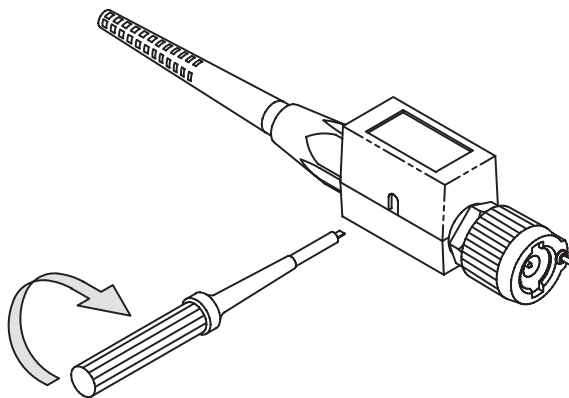

Figure 3: P6106A Probe Trimmer Adjustment

High-Frequency Probe Compensation

The probe high-frequency compensation should seldom require adjustment; however, your probe may require high-frequency adjustment if any of the following are true:

- the probe has excessive high-frequency aberrations
- the probe does not perform at the rated bandwidth
- you have installed the probe on an oscilloscope having an input capacitance near the limits of the probe compensation range (see Table 1 on page 8)

To perform the high-frequency compensation adjustment you will need a signal source that has all of the following characteristics:

- square-wave output at 1 MHz
- fast rise output with rise time less than 1 ns
- output terminated into 50 Ω load

NOTE. We strongly recommend that you use the optional probe tip-to-BNC adapter (Tektronix part number 013-0084-04) to connect your probe to the signal source.

1. Remove the covers from the probe compensation box by gently prying them off with a fingernail or small screwdriver.
2. Connect the probe to the signal source and display a 1 MHz test signal on your oscilloscope. Adjust your oscilloscope to 5 ns/division. The display should be similar to that shown in Figure 4(a).

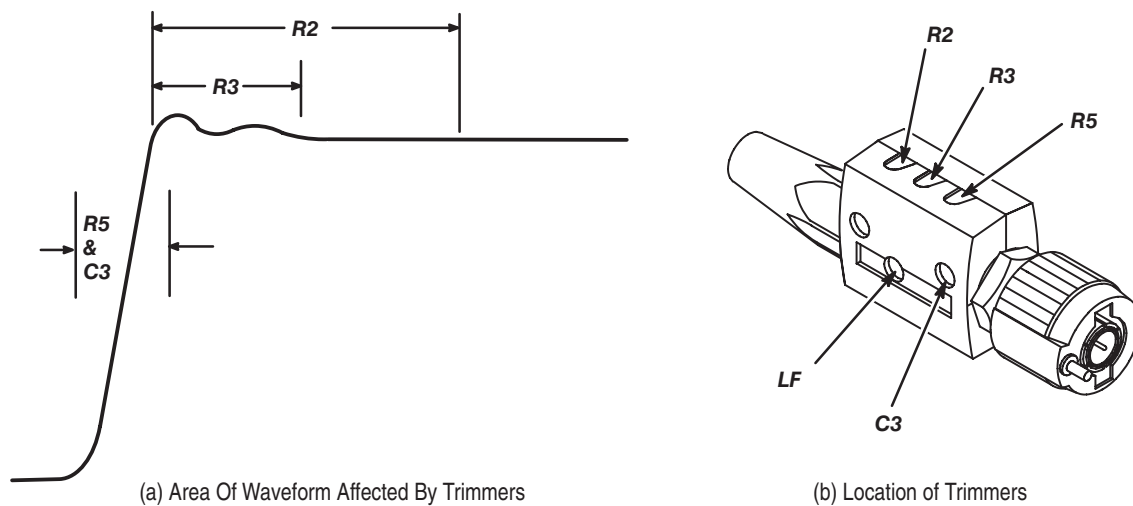

Figure 4: Adjusting High-Frequency Compensation

3. Adjust R2 to flatten the first 40 ns of the waveform.
4. Adjust R3 to flatten the first 20 ns of the waveform. You may need to alternately adjust R2 and R3 for an optimal waveform.
5. Adjust R5 clockwise to flatten the first 5 ns of the waveform.
6. Adjust C3 for as square a leading edge as possible. (The effect of C3 is easier to see at 2 ns/division.)

Specifications

Table 1: Electrical characteristics¹

Characteristic	Description
Attenuation ²	10X: ±3.0% at DC
Input resistance ²	10 MΩ ±2.0% at DC (see Figure 6)
Input Capacitance	
1.0-meter (Option 01)	≈8.7 pF
2.0-meter (standard)	≈11.2 pF
Compensation Range	
1.0-meter (Option 01)	15 pF to 35 pF
2.0-meter (standard)	15 pF to 35 pF
System Bandwidth (–3 dB)	
1.0-meter (Option 01)	250 MHz
2.0-meter (standard)	250 MHz
Maximum Input Voltage ^{3,4}	450 V RMS CAT I or 450 V DC CAT I 300 V RMS CAT II or 300 V DC CAT II 150 V RMS CAT III or 150 V DC CAT III 630 V peak, @50% DF, <1 sec PW 1000 V peak, @20% DF, <1 sec PW 1050 V peak, @10% DF, <50 μs PW See Figure 7 for voltage derating curve.

¹ Probe installed on Tektronix 475A/7A26 or equivalent 250 MHz oscilloscope.

² System characteristic.

³ As defined in EN61010-1. See Certifications and compliances in Table 3

⁴ RMS=Root Mean Square=rms=The square root of the average of the sum of the squares of the instantaneous voltage in one cycle = $\sqrt{\sum (fx_i)^2/n}$.

300 VDC=300V RMS, 420 V Peak (sinewave)=300 V RMS See Figure 5.

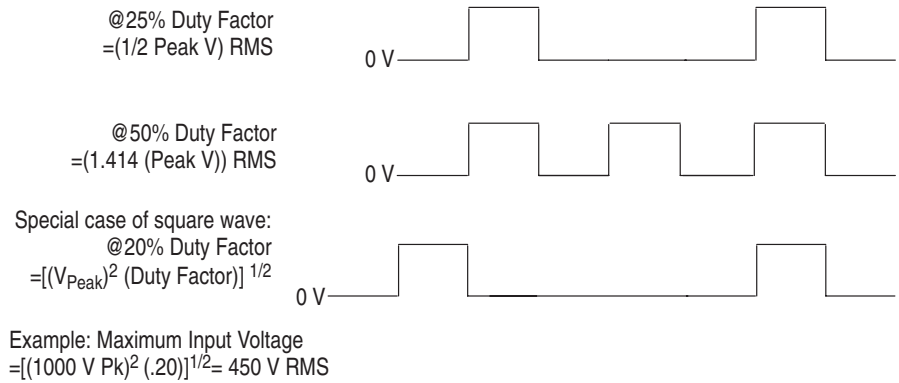

Figure 5: Maximum input voltage calculation example

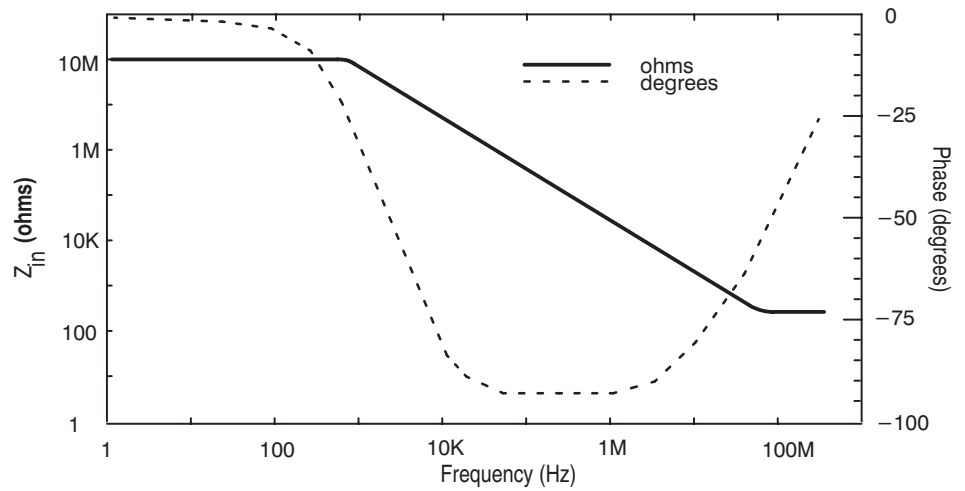

Figure 6: Input Impedance by Frequency

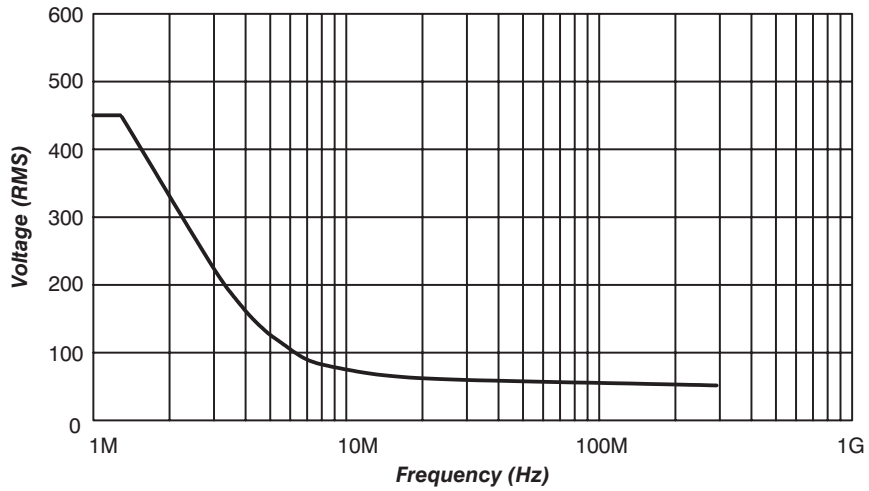

Figure 7: Derating Curve for Determining Maximum Input Voltage

Table 2: Physical and Environmental Characteristics

Characteristic	Performance Requirement
Net Weight (including accessories)	<110 g (0.24 lbs)
Temperature Range ¹	
Operating	-15°C to +65°C (+5°F to +149°F)
Nonoperating	-62°C to +85°C (-80°F to +185°F)
Humidity ¹	95% to 97% Relative Humidity
Altitude	< 2000 meters

¹ Tek Standard 062-2847-00, class 3. Refer to MIL-E-16400F, paragraph 4.5.9 through 4.5.9.5.1, class 4.

Table 3: Certifications and compliances

EC Declaration of Conformity	<p>Compliance was demonstrated to the following specification as listed in the Official Journal of the European Communities:</p> <p>Low Voltage Directive 73/23/EEC as amended by 93/68/EEC:</p> <p>EN 61010-1/A2 Safety requirements for electrical equipment for measurement, control, and laboratory use</p> <p>EN 61010-2-031:1994 Particular requirements for hand-held probe assemblies for electrical measurement and test</p>
------------------------------	---

Table 3: Certifications and compliances (Cont.)

Overvoltage Category	Category:	Examples of Products in this Category:
	CAT III	Distribution-level mains, fixed installation
	CAT II	Local-level mains, appliances, portable equipment
	CAT I	Signal levels in special equipment or parts of equipment, telecommunications, electronics
Pollution Degree 2	Do not operate in environments where conductive pollutants may be present.	
Safety	UL3111-1, First Edition & IEC61010-2-031, First Edition CSA C22.2 No. 1010.1-92 & CAN/CSA C22.2 No. 1010.2.031-94 EN61010-1/A2 EN61010-2-031 Pollution Degree 2	

Maintenance

The information in this section will help you maintain your probe for a long service life.

Cleaning

To prevent damage to probe materials, avoid using chemicals that contain benzene, toluene, xylene, acetone, or similar solvents.

Remove accumulated loose dust from the probe exterior using a soft cloth or small brush. Remaining dirt may be removed with a soft cloth dampened with a mild detergent and water solution, or isopropyl alcohol. Do not immerse the probe or use abrasive cleaners.

Replacing Probe Modules

The probe can be disassembled into three easy-to-replace modules: the probe head, the cable assembly, and the compensation box assembly. Refer to Figure 8. Individual components within the compensation box are not replaceable.

NOTE. *The probe head, cable, and compensation box are not interchangeable between probe options. Be certain to specify Standard or Option 01 when ordering replacement parts.*

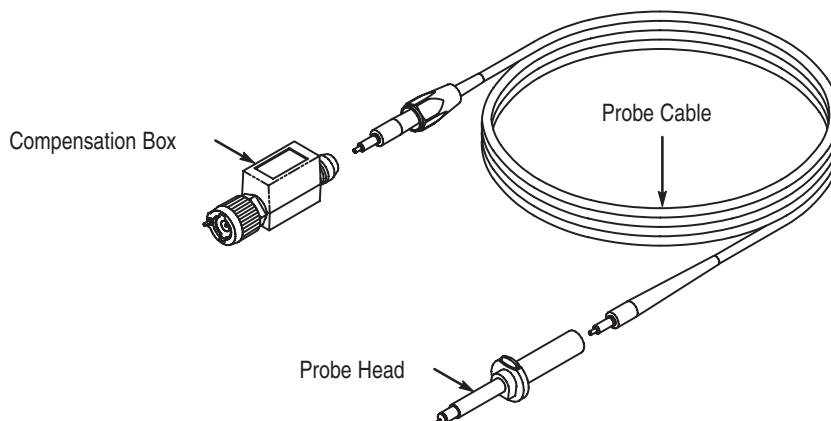

Figure 8: P6106A Replaceable Modules

- **Probe head**—To remove the probe head, simply pull it free from the cable. To reinstall the probe head, push the cable end into the head until the connector snaps into place.
- **Compensation box**—To remove the compensation box, unscrew the tapered retainer and slide it along the cable, away from the compensation box. Withdraw the cable from the compensation box. To reinstall the compensation box, reverse the procedure.
- **Probe cable**—To replace the probe cable, remove the probe head and compensation box as described above. To reassemble your probe, reverse the procedure.

Replacing Probe Tips

Replacement probe tips are available as optional accessories. Instructions for replacing the probe tip are included in the package of replacement tips. Refer to *Replaceable Parts* for more information.

Replaceable Parts

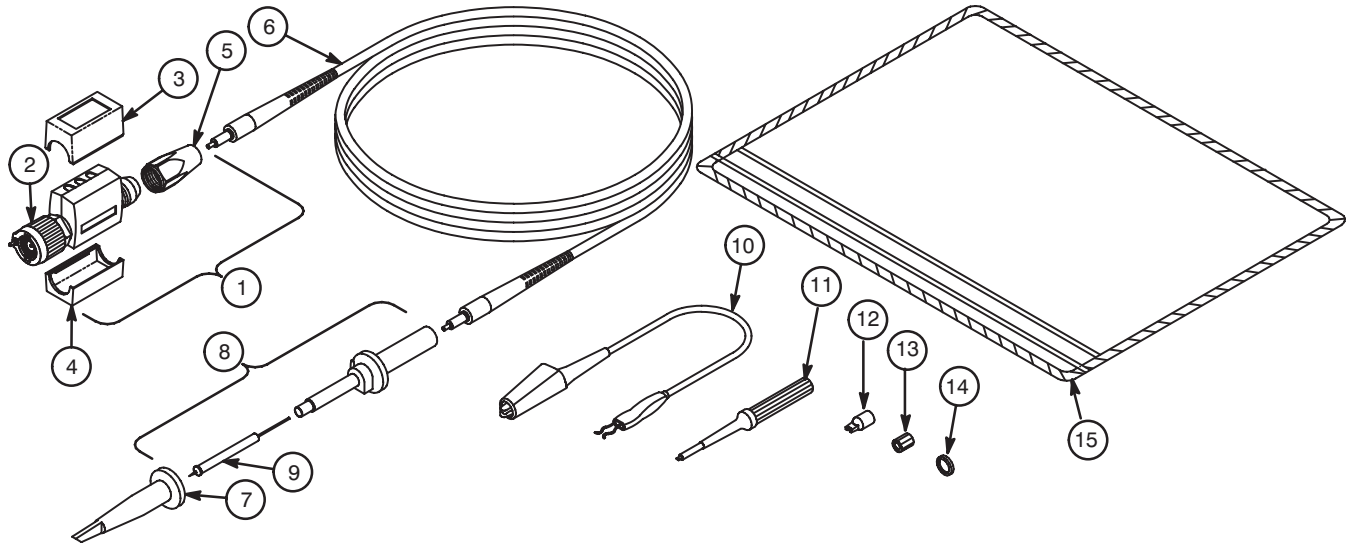

Figure 9: P6106A Exploded View

Replaceable mechanical parts list

Fig. & index number	Tektronix part number	Serial no. effective	Serial no. discont'd	Qty	Name & description	Mfr. code	Mfr. part number
P6106A							
9-					PROBE,PASSIVE250 MHZ,10X W/RO 2M (STANDARD ONLY) PROBE,PASSIVE:250 MHZ,10X W/RO 1M (OPTION 01 ONLY)		
-1	206-0319-01			1	.COMP BOX ASSY:2.0 METER (STANDARD ONLY)	80009	206-0319-01
	206-0313-01			1	.COMP BOX ASSY:1.0 METER (OPTION 01 ONLY)	80009	206-0313-01
-2	131-3219-00			1	..CONN,RCPT,ELEC:BNC,MALE	24931	28P266-3
-3	200-3016-00			1	..COVER,COMP BOX:TOP,ABS DOVE GRAY	80009	200-3016-00
-4	200-3017-00			1	..COVER,COMP BOX:BOTTOM,ABS SLATE GRAY	80009	200-3017-00
-5	200-3018-00			1	..COVER,CABLE NIP:COMP BOX	0J260	ORDER BY DESC
-6	174-0976-00			1	.CABLE ASSY,RF:39 OHM COAX,2.0 M (STANDARD ONLY)	80009	174-0976-00
	174-0975-00			1	.CABLE ASSY,RF:39 OHM COAX,1.0M (OPTION 01 ONLY)	80009	174-0975-00
-7	013-0107-07			1	.TIP,PROBE:MINI/COMPACT SIZE,RETRACT HOOK ASSY	80009	013-0107-07

Replaceable mechanical parts list (Cont.)

Fig. & index number	Tektronix part number	Serial no. effective	Serial no. discont'd	Qty	Name & description	Mfr. code	Mfr. part number
-8	206-0301-00			1	.PROBE HEAD:2.0 METER .(STANDARD ONLY)	80009	206-0301-00
	206-0328-00			1	.PROBE HEAD:1.0 METER CABLES,H951 .(OPTION 01 ONLY)	80009	206-0328-00
-9	206-0337-01			1	..PROBE HEAD:2.0 METER,PKG OF 5 ..(STANDARD ONLY)	80009	206-0337-01
	206-0336-01			1	..PROBE HEAD:1.0 METER,PKG OF 5 ..(OPTION 01 ONLY)	80009	206-0336-01
STANDARD ACCESSORIES							
-10	196-3120-01			1	LEAD,ELECTRICAL:GROUND,23 AWG,6.0 L	80009	196-3120-01
-11	003-1433-02			1	SCREWDRIVER:ADJUSTMENT TOOL	80009	003-1433-02
-12	_____			1	TIP,PROBE:IC TEST (SEE OPTIONAL ACCESSORIES)		
-13	166-0404-01			1	COVER,GROUND:	80009	166-0404-01
-14	016-0633-00			1	MARKER SET,CA:2 EA VARIOUS COLORS	80009	016-0633-00
-15	016-1644-00			1	POUCH,ACCESSORY:6.25 X 9.25	80009	016-1644-00
	070-5517-03			1	SHEET,TECHNICAL:INSTRUCTION,P6106A	80009	070-5517-03
OPTIONAL ACCESSORIES							
	015-0201-07			1	TIP,PROBE:IC TEST,PKG OF 10	80009	015-0201-07
	015-0201-08			1	TIP,PROBE:IC TEST,PKG OF 100	80009	015-0201-08
	003-1433-02			1	SCREWDRIVER:ADJUSTMENT TOOL	80009	003-1433-02
	016-0633-00			1	MARKER SET,CA:2 EA VARIOUS COLORS	80009	016-0633-00
	344-0046-01			1	CLIP,ELECTRICAL:ALLIGATOR	80009	344-0046-01

Manufacturers cross index

Mfr. code	Manufacturer	Address	City, state, zip code
TK1556	CONSOLIDATED VINYL SALES	1237 S SAN GABRIEL BLVD	SAN GABRIEL CA 91776
0J260	COMTEK MFG OF OREGON	PO BOX 4200	BEAVERTON OR 97076-4200
24931	FCI/BERG ELECTRONICS INC	RF/COAXIAL DIV 2100 EARLYWOOD DR PO BOX 547	FRANKLIN, IN 46131
80009	TEKTRONIX INC	14150 SW KARL BRAUN DR PO BOX 500	BEAVERTON OR 97077-0001