



All references to the SA 501 in this manual now apply to the 067-1090-00 Signature Analyzer.

**PLEASE CHECK FOR CHANGE INFORMATION
AT THE REAR OF THIS MANUAL.**

**DM 5010
PROGRAMMABLE
DIGITAL
MULTIMETER**

Francais Deutsch

INSTRUCTION MANUAL

**Tektronix, Inc.
P.O. Box 500
Beaverton, Oregon 97077
070-2994-01
Product Group 76**

Serial Number _____

First Printing SEP 1981
Revised JUL 1986

Copyright © 1981 Tektronix, Inc. All rights reserved.
Contents of this publication may not be reproduced in any
form without the written permission of Tektronix, Inc.

Products of Tektronix, Inc. and its subsidiaries are covered
by U.S. and foreign patents and/or pending patents.

TEKTRONIX, TEK, SCOPE-MOBILE, and  are
registered trademarks of Tektronix, Inc. TELEQUIPMENT
is a registered trademark of Tektronix U.K. Limited.

Printed in U.S.A. Specification and price change privileges
are reserved.

Copyright © 1986 durch Tektronix, Inc. Alle Rechte vorbe-
halten. Der Inhalt dieser Publikation darf ohne Genehmigung
von Tektronix, Inc. nicht weitergegeben werden.

Produkte von Tektronix, Inc. und seinen Tochtergesellschaften
sind durch US- und Auslandspatente und/oder schwebende
Patente abgedeckt.

TEKTRONIX, TEK, SCOPE-MOBILE und  sind geschützte
Warenzeichen von Tektronix, Inc.

Gedruckt in U.S.A. Spezifikations- und Preisänderungen
bleiben vorbehalten.

Copyright © 1986 TEKTRONIX INC. Tous droits réservés.
Le contenu de ce manuel ne peut être reproduit sous quelque for-
me que ce soit sans l'accord de Tektronix Inc.

Tous les produits TEKTRONIX sont brevetés US et Etranger et
les logotypes TEKTRONIX, TEK SCOPE MOBILE,  sont
déposés.

Imprimé aux USA. TEKTRONIX se réserve le droit de modifier
caractéristiques et prix dans le cadre de développements techno-
logiques.

INSTRUMENT SERIAL NUMBERS

Each instrument has a serial number on a panel insert, tag,
or stamped on the chassis. The first number or letter
designates the country of manufacture. The last five digits
of the serial number are assigned sequentially and are
unique to each instrument. Those manufactured in the
United States have six unique digits. The country of
manufacture is identified as follows:

| | |
|---------|---|
| B000000 | Tektronix, Inc., Beaverton, Oregon, USA |
| 100000 | Tektronix Guernsey, Ltd., Channel Islands |
| 200000 | Tektronix United Kingdom, Ltd., London |
| 300000 | Sony/Tektronix, Japan |
| 700000 | Tektronix Holland, NV, Heerenveen, The Netherlands |

TABLE OF CONTENTS

| | Page | | Page |
|---|------|--|------|
| LIST OF ILLUSTRATIONS | iii | Mesures de tensions alternatives..... | 2-9 |
| LIST OF TABLES | iv | Vitesses de conversion | 2-9 |
| OPERATORS SAFETY SUMMARY | v | Déclenchement..... | 2-9 |
| SERVICE SAFETY SUMMARY..... | vii | Calculs..... | 2-10 |
| Section 1 SPECIFICATION | | Modification des valeurs des constantes..... | 2-10 |
| Introduction | 1-1 | Tableau 2.4 - Fonctions calcul et constantes associées..... | 2-10 |
| Standard Accessories | 1-1 | Exemples de calculs | 2-11 |
| IEEE 488 (GPIB) Functions | 1-1 | Instructions de réemballage..... | 2-12 |
| Performance Conditions | 1-1 | | |
| Section 2 OPERATING INSTRUCTIONS | | Abschnitt 2 BEDIENUNGSANLEITUNG | |
| Introduction..... | 2-1 | Section 3 PROGRAMMING | |
| Preparation For Use | 2-1 | Introduction..... | 3-1 |
| Installation and Removal | 2-1 | Talk Only Mode | 3-1 |
| Front Panel Controls and Connectors .. | 2-2 | Commands | 3-3 |
| General Information | 2-2 | Functional Command List | 3-3 |
| Display Window | 2-2 | Detailed Command List..... | 3-5 |
| Controls and Connectors | 2-4 | Messages and Communication | |
| Operators Familiarization | 2-6 | Protocol..... | 3-21 |
| Power On Self Test | 2-6 | Command Separator | 3-21 |
| General Operating Information..... | 2-7 | Message Terminataor..... | 3-21 |
| Input Connections | 2-7 | Formatting a Message | 3-21 |
| Rear Interface Measurements | 2-7 | Number Formats..... | 3-21 |
| Dc Voltage Measurements..... | 2-9 | Message Protocol..... | 3-22 |
| Resistance Measurements..... | 2-9 | Multiple Messages | 3-22 |
| Measuring Diodes..... | 2-9 | Instrument Response to IEEE 488 | |
| Ac Voltage Measurments | 2-9 | Interface Messages | 3-22 |
| Conversion Rates..... | 2-9 | Remote-Local Operation | 3-23 |
| Triggering | 2-9 | Status and Error Reporting..... | 3-24 |
| Calculations | 2-10 | Sending Interface Commands..... | 3-26 |
| Changing Constant Values..... | 2-10 | Power On (Initial) Conditions..... | 3-26 |
| Calculation Examples | 2-11 | Example Programs | 3-28 |
| Repackaging Information | 2-12 | Programming Aids..... | 3-29 |
| Chapitre 2 INSTRUCTIONS D'UTILISATION | | Handling Service Requests..... | 3-29 |
| Introduction..... | 2-1 | Front Panel Lockout..... | 3-29 |
| Préparation..... | 2-1 | Using INIT..... | 3-29 |
| Installation et retrait de l'appareil | 2-1 | Invalidating a Pending Reading | 3-29 |
| Commandes et connecteurs de la face avant..... | 2-2 | Allowing Setting Time!..... | 3-30 |
| Fenêtre d'affichage..... | 2-2 | Triggering Measurements..... | 3-30 |
| Commandes et connecteurs..... | 2-4 | Determining Reading Availability | 3-30 |
| Tableau 2-2 - Codes d'erreur affichés en face avant..... | 2-7 | Sending Readings to a Listener | 3-30 |
| Instructions générales d'utilisation..... | 2-7 | | |
| Connexions d'entrée | 2-7 | Chapitre 3 PROGRAMMATION | |
| Mesures sur l'interface arrière | 2-8 | Introduction..... | 3-1 |
| Mesures de tensions continues | 2-9 | Mode Emetteur-seulement (Talk only)..... | 3-1 |
| Mesures de résistances..... | 2-9 | Commands | 3-3 |
| Tableau 2.3 - Tensions de source (fonction ohms)..... | 2-9 | Liste de commandes fonctionnelles | 3-3 |
| | | Commandes de l'instrument..... | 3-3 |
| | | Commandes d'entrée/sortie | 3-4 |

TABLE OF CONTENTS (cont)

| | |
|--|------|
| Commandes du système | 3-4 |
| Commandes d'état | 3-4 |
| Liste de commandes détaillées | 3-5 |
| Messages et protocole de communication | 3-21 |
| Délimiteur de commande | 3-21 |
| Fin de message | 3-21 |
| Formatage d'un message | 3-21 |
| Format des arguments numériques | 3-21 |
| Protocole des messages | 3-22 |
| Messages multiples | 3-22 |
| Reponse de l'instrument aux messages de l'interface IEEE-488 | 3-22 |
| Indications d'états et d'erreurs | 3-24 |
| Tableau 3.1 - Indications d'erreurs et d'états | 3-25 |
| Tableau 3.2 - Codes d'erreur visualisés en face avant | 3-25 |
| Transmission de messages de contrôle de l'interface | 3-26 |
| Réglages effectués à la mise en service | 3-26 |
| Tableau 3.3 - Réglages existants à la mise sous tension | 3-26 |
| Table de conversion ASCII et IEEE 488 (GPIB) | 3-27 |
| Aide à la programmation du DM 5010 | 3-29 |
| Traitement des demandes de service | 3-29 |
| Blocage de la face avant | 3-29 |
| Utilisation de la commande INIT | 3-29 |
| Invalidation d'une mesure en attente | 3-29 |
| Temps d'établissement | 3-30 |
| Mesures par déclenchement | 3-30 |
| Disponibilité d'une mesure | 3-30 |
| Transmission de mesures à un récepteur | 3-30 |

| | |
|---|--------------|
| Abschnitt 3 PROGRAMMIERUNG | Seite |
| Einführung | 3-1 |
| Betriebsart Talk Only | 3-1 |
| Befehle | 3-3 |
| Liste der funktionellen Befehle | 3-3 |
| Detaillierte Befehlsliste | 3-3 |
| Mitteilungen und Kommunikationsprotokoll | 3-21 |
| Befehls-Trennzeichen | 3-21 |
| Mitteilungs-Endezeichen | 3-21 |
| Formatierung einer Mitteilung | 3-21 |
| Zahlen-Formate | 3-21 |
| Mitteilungs-Protokoll | 3-22 |
| Mehrfach-Mitteilungen | 3-22 |
| Gerätreaktionen auf IEEE 488 Interface-Mitteilungen | 3-22 |
| Remote-Local Operation | 3-23 |
| Status- und Fehlerbericht | 3-24 |

| | |
|---|------|
| Das Senden von Interface Steuermittellungen | 3-26 |
| Einschalt- (Anfangs-) Bedingungen | 3-26 |
| Programmbeispiele | 3-28 |
| Programmierungshilfen | 3-29 |
| Behandlung von Service-Abfragen | 3-30 |
| Interrupt Handler | 3-30 |
| Frontplatten-Abschaltung | 3-30 |
| Die Verwendung von INIT | 3-30 |
| Löschen einer Darstellung | 3-30 |
| Allowing Settling Time | 3-30 |
| Getriggerte Messungen | 3-30 |
| Verfügbarkeit von Ablesungen | 3-30 |
| Senden an einen Hörer (Listener) | 3-30 |

WARNING

THE FOLLOWING SERVICING INSTRUCTIONS ARE FOR USE BY QUALIFIED PERSONNEL ONLY. TO AVOID PERSONAL INJURY, DO NOT PERFORM ANY SERVICING INSTRUCTIONS UNLESS YOU ARE QUALIFIED TO DO SO.

Section 4 THEORY OF OPERATION

| | |
|------------------------------------|------|
| Block Diagram Description | 4-1 |
| Detailed Circuit Description | 4-4 |
| Attenuator | 4-5 |
| DCV signal conditioner | 4-6 |
| Charge Balancing converter | 4-7 |
| Auto Zero | 4-8 |
| Isolated Regulators | 4-12 |
| Function and Range Control | 4-13 |
| Ohms Converter | 4-14 |
| RMS Converter | 4-14 |
| Grounded Power Supplies | 4-14 |
| Isolated Power Supplies | 4-16 |
| Control Logic | 4-16 |
| Timing Logic | 4-18 |
| Data | 4-20 |
| Microprocessor | 4-21 |
| GPIB | 4-25 |

Section 5 PERFORMANCE CHECK

| | |
|---------------------------------------|------|
| Introduction | 5-1 |
| Test Equipment Required | 5-1 |
| Preparation | 5-2 |
| Performance Check Summary Sheet | 5-13 |

TABLE OF CONTENTS (cont)

| | | |
|-------------------|---|-----|
| Section 6 | ADJUSTMENT PROCEDURE | |
| | Introduction | 6-1 |
| | Services Available | 6-1 |
| | Test Equipment Required | 6-1 |
| | Preparation | 6-3 |
| | | |
| Section 7 | MAINTENANCE | |
| | Preparation For Use | 7-1 |
| | Setting the GPIB Address Switches | 7-1 |
| | Message Terminator Switch Setting | 7-2 |
| | Talk Only Switch Setting | 7-2 |
| | Using the Rear Interface | |
| | Connections | 7-2 |
| | General Maintenance | 7-2 |
| | Rear Circuit Board Removal | 7-2 |
| | Front Panel Board Removal | 7-2 |
| | Input Switch Assembly | 7-4 |
| | Adjusting C1301 and C1404 | 7-4 |
| | Battery Replacement | 7-4 |
| | Troubleshooting Aids | 7-5 |
| | Calibration Fixtures | 7-5 |
| | Troubleshooting Equipment | 7-5 |
| | Static-Sensitive Components | 7-5 |
| | Obtaining Replacement Parts | 7-6 |
| | Soldering Techniques | 7-6 |
| | Semiconductors | 7-7 |
| | | |
| Section 8 | OPTIONS | |
| | | |
| Section 9 | REPLACEABLE ELECTRICAL PARTS | |
| | | |
| Section 10 | DIAGRAMS AND CIRCUIT BOARD ILLUSTRATIONS | |
| | | |
| Section 11 | REPLACEABLE MECHANICAL PARTS | |
| | | |
| | Accessories | |
| | Change Information | |

LIST OF ILLUSTRATIONS

| Fig. No. | Page | Fig. No. | Page |
|----------|--|----------|--|
| | | 5-1 | Common mode check setup 5-7 |
| 2-1 | DM 5010 Programmable Digital Multimeter Plug-in installation and removal 2-1 | 5-2 | Dc normal mode rejection setup 5-8 |
| 2-2 | DM 5010 front panel range indication 2-2 | 5-3 | Ohms accuracy setup 5-10 |
| 2-3 | DM 5010 front panel controls and connectors 2-3 | 6-1 | Ohms adjustment setup 6-5 |
| 2-4 | Examples of front panel input connection methods 2-8 | 7-1 | GPIB address and message terminator switches 7-1 |
| 2-5 | Setup for calculation example 1 2-11 | 7-2 | Back plate and retainer bar removal 7-2 |
| 2-6 | Setup for calculation example 2 2-12 | 7-3 | Latch disassembly 7-3 |
| 3-1 | Instrument commands and relationship to front panel controls 3-2 | 7-4 | Front panel removal 7-3 |
| 3-2 | Definition of STB bits 3-24 | 7-5 | Setup for C1301 and C1404 adjustment . . . 7-4 |
| 3-3 | ASCII and IEEE 488 (GPIB) Code Chart . . 3-27 | 7-6 | Location of C1301 and C1404 7-5 |
| 4-1 | Attenuator 4-5 | 7-7 | I M/Z, I U/D, ICOMP and the zero-reference voltage waveforms after power on 7-16 |
| 4-2 | Simplified overvoltage protection and function switching 4-6 | 7-8 | FET Gate timing diagram 7-16 |
| 4-3 | Simplified DCV signal conditioner buffer amplifier 4-7 | 7-9 | Over-voltage protection and function switching waveform 7-17 |
| 4-4 | Simplified DCV signal conditioner bootstrap buffer 4-8 | 7-10 | DCV Signal Conditioner and Charge-Balancing Converter waveform. 7-17 |
| 4-5 | Simplified charge-balancing converter 4-9 | | |
| 4-6 | U/D control for the measurement, override, and auto-zero periods 4-10 | | |
| 4-7 | Charge-balancing converter configuration during the auto-zero period. 4-11 | | |
| 4-8 | Override and auto-zero timing for measurement period ending 4-12 | | |
| 4-9 | Simplified function and range control circuitry . 4-13 | | |
| 4-10 | Measurement switching during an Ohms conversion 4-15 | 10-1 | Jumper and GPIB address switch locations |
| 4-11 | Transformer drive timing 4-16 | 10-2 | Location of DM 5010 adjustments and test points |
| 4-12 | Timing of the divide by eighteen counter . . 4-18 | 10-2 | ADC Board (A17) |
| 4-13 | Influence of power line frequency on A/D conversion 4-20 | 10-4 | RMS Board (A16) |
| 4-14 | GPIB three wire handshake state diagram . 4-26 | 10-5 | Isolation Board (A15) |
| 4-15 | GPIB handshake flowchart 4-27 | 10-6 | CPU Board (A14) |
| | | 10-7 | Main Interconnect Board (A13) |
| | | 10-8 | Front Panel Drive Board (A12) |
| | | 10-9 | Front Panel Board (A11) |
| | | 11-1 | Exploded View |

NOTE

The following illustrations are located in the diagrams foldout section at the rear of this manual.

LIST OF TABLES

| Table No. | | Page | Table No. | | Page |
|-----------|--|------|-----------|---|------|
| 1-1 | IEEE 488 Interface Function Subsets | 1-1 | 7-6 | No Load Power Supply Voltages | 7-13 |
| 1-1 | Electrical Characteristics | 1-2 | 7-7 | Error Code 311 Faults | 7-14 |
| 1-3 | Miscellaneous | 1-8 | 7-8 | Attenuator Faults | 7-15 |
| 1-4 | Environmental | 1-9 | 7-9 | DCV Signal Conditioner Faults | 7-15 |
| 1-5 | Physical Characteristics | 1-10 | 7-10 | Charge-Balancing Converter Faults | 7-15 |
| 2-1 | Power On Settings (Front Panel Functions Only) | 2-6 | 7-11 | RMS Converter Faults | 7-17 |
| 2-2 | Front Panel Error Codes | 2-7 | 7-12 | RMS Converter Faults | 7-17 |
| 2-3 | Source Voltages (Ohms Function) | 2-9 | 7-13 | Power Supply Reference Voltages | 7-18 |
| 2-4 | Calculations and Constants | 2-10 | 7-14 | Ohms Converter Faults | 7-18 |
| 3-1 | Error Query and Status Information | 3-25 | 7-15 | Signature Versions | 7-19 |
| 3-2 | Front Panel Error Codes | 3-25 | | | |
| 3-3 | DM 5010 Power On Settings | 3-26 | | | |
| 4-1 | DCV Signal Conditioner Gain Settings | 4-6 | | | |
| 4-2 | Ohms converter Parameters | 4-14 | | | |
| 4-3 | RMS Converter Parameters | 4-15 | | | |
| 4-4 | Address Decoding | 4-22 | | | |
| 4-5 | Address Decode Memory Map | 4-23 | | | |
| 5-1 | Test Equipment List | 5-1 | | | |
| 5-2 | Dc Voltage Accuracy | 5-3 | 10-1 | Component Reference Chart | |
| 5-3 | Ac Voltage Accuracy | 5-4 | 10-2 | Input and Attenuation Switching | |
| 5-4 | Ac Voltage Accuracy | 5-6 | 10-3 | Component Reference Chart | |
| 5-5 | Dc Normal Mode Rejection | 5-9 | 10-4 | Component Reference Chart | |
| 5-6 | Ohms Offset Accuracy | 5-9 | 10-5 | Input and Attenuation Switching | |
| 5-7 | Ohms Gain Accuracy | 5-11 | 10-6 | Component Reference Chart | |
| 6-1 | Test Equipment List | 6-1 | 10-7 | Component Reference Chart | |
| 6-2 | Dcv Offset Calibration Factors | 6-3 | 10-8 | Component Reference Chart | |
| 6-3 | Dcv Gain Calibration Factors | 6-4 | 10-9 | Component Reference Chart | |
| 6-4 | Ohms Offset Calibration Factors | 6-4 | 10-10 | Component Reference Chart | |
| 6-5 | Ohms Gain Calibration Factors | 6-6 | 10-11 | Component Reference Chart | |
| 6-6 | Acv Gain Calibration Factors | 6-7 | 10-12 | Component Reference Chart | |
| 7-1 | IEEE 488 (GPIB) Primary Addresses | 7-1 | 10-13 | Rear Interface Connector Assignments | |
| 7-2 | Relative Susceptibility to Static Discharge | 7-6 | 10-14 | Rear Interface Connector Assignments | |
| 7-3 | Typical Trouble Symptoms | 7-9 | 10-15 | Rear Interface Connector Assignments | |
| 7-4 | No Load Power Supply Voltages | 7-12 | 10-16 | Component Reference Chart | |
| 7-5 | Power Supply and Reference Voltages | 7-13 | 10-17 | Component Reference Chart | |

NOTE

The following tables are located in the diagrams foldout section at the rear of this manual.

OPERATORS SAFETY SUMMARY

The general safety information in this part of the summary is for both operating and servicing personnel. Specific warnings and cautions will be found throughout the manual where they apply, but may not appear in this summary.

TERMS

In This Manual

CAUTION statements identify conditions or practices that could result in damage to the equipment or other property.

WARNING statements identify conditions or practices that could result in personal injury or loss of life.

As Marked on Equipment

CAUTION indicates a personal injury hazard not immediately accessible as one reads the marking, or a hazard to property including the equipment itself.

DANGER indicates a personal injury hazard immediately accessible as one reads the marking.

SYMBOLS

In This Manual



This symbol indicates where applicable cautionary or other information is to be found.

As Marked on Equipment



DANGER — High voltage.



Protective ground (earth) terminal.



ATTENTION — refer to manual.

Power Source

This product is intended to operate from a power module connected to a power source that will not apply more than 250 volts rms between the supply conductors or between either supply conductor and ground. A protective ground connection by way of the grounding conductor in the power cord is essential for safe operation.

Grounding the Product

This product is grounded through the grounding conductor of the power module power cord. To avoid electrical shock, plug the power cord into a properly wired receptacle before connecting to the product input or output terminals. A protective ground connection by way of the grounding conductor in the power module power cord is essential for safe operation.

Danger Arising From Loss of Ground

Upon loss of the protective-ground connection, all accessible conductive parts (including knobs and controls that may appear to be insulating) can render an electric shock.

Use the Proper Fuse

To avoid fire hazard, use only the fuse of correct type, voltage rating and current rating as specified in the parts list for your product.

Refer fuse replacement to qualified service personnel.

Do Not Operate in Explosive Atmospheres

To avoid explosion, do not operate this product in an explosive atmosphere unless it has been specifically certified for such operation.

Do Not Operate Without Covers

To avoid personal injury, do not operate this product without covers or panels installed. Do not apply power to the plug-in via a plug-in extender.

SERVICE SAFETY SUMMARY

FOR QUALIFIED SERVICE PERSONNEL ONLY

Refer also to the preceding Operators Safety Summary

Do Not Service Alone

Do not perform internal service or adjustment of this product unless another person capable of rendering first aid and resuscitation is present.

Use Care When Servicing With Power On

Dangerous voltages may exist at several points in this product. To avoid personal injury, do not touch exposed connections and components while power is on.

Disconnect power before removing protective panels, soldering, or replacing components.

Power Source

This product is intended to operate in a power module connected to a power source that will not apply more than 250 volts rms between the supply conductors or between either supply conductor and ground. A protective ground connection by way of the grounding conductor in the power cord is essential for safe operation.

RECAPITULATIF DES CONSIGNES DE SECURITE

Termes utilisés dans ce manuel

Les paragraphes intitulés ATTENTION identifient les circonstances ou opérations pouvant entraîner la détérioration de l'appareil ou de tout autre équipement.

Les paragraphes intitulés AVERTISSEMENT indiquent les circonstances dangereuses pour l'utilisateur (danger de mort ou risque de blessure).

Repères gravés sur l'appareil

CAUTION (ATTENTION) : ce mot identifie les zones de risque de blessure non perceptibles immédiatement ou un risque éventuel de détérioration de l'appareil.

DANGER (DANGER) : ce mot indique les zones de risque immédiat pouvant entraîner blessures ou mort.

Symboles gravés sur l'équipement



DANGER – Haute tension



Borne de masse de protection (terre)



ATTENTION – se reporter au manuel

Source d'alimentation

L'appareil est conçu pour fonctionner à partir d'une source d'alimentation maximale de 250 V efficaces entre les conducteurs d'alimentation ou entre chaque conducteur d'alimentation et la terre. Pour utiliser l'appareil en toute sécurité, une connexion à la masse, réalisée au moyen d'un conducteur prévu dans le cordon d'alimentation, est indispensable.

Mise à la masse de l'appareil

Une fois installé dans le châssis d'alimentation, l'appareil est relié à la masse à l'aide d'un conducteur du cordon d'alimentation. Pour éviter tout choc électrique, insérer la prise du cordon d'alimentation dans une prise de distribution correspondante avant de connecter l'entrée ou les sorties de l'appareil. Pour utiliser l'appareil en toute sécurité, une connexion à la masse réalisée au moyen d'un conducteur prévu dans le cordon d'alimentation, est indispensable.

Danger provoqué par la coupure de connexion de masse

En cas de coupure de la connexion de masse, tous les éléments conducteurs accessibles (y compris boutons et commandes apparaissant isolants) peuvent provoquer un choc électrique.

Utiliser le cordon d'alimentation approprié

N'utiliser que le cordon d'alimentation et la prise recommandés pour votre appareil. Utiliser un cordon d'alimentation en parfait état. Seul, un personnel qualifié peut procéder à un changement de cordon et prises.

Utiliser le fusible approprié

Pour éviter tout risque d'accident (incendie...) n'utiliser que le fusible recommandé pour votre appareil. Le fusible de remplacement doit toujours correspondre au fusible remplacé : même type, même tension et même courant. Un remplacement de fusible ne doit être effectué que par un personnel qualifié.

Ne pas utiliser l'appareil en atmosphère explosive

Pour éviter toute explosion, ne pas utiliser cet appareil dans une atmosphère de gaz explosifs.

Ne pas démonter les capots

Pour éviter toute blessure, ne pas utiliser cet appareil sans capots ou panneaux. Ne pas alimenter le tiroir à travers un prolongateur.

CONSIGNES DE SECURITE

UNIQUEMENT DESTINEES AU PERSONNEL DE MAINTENANCE

Ne dépannez pas seul

Ces consignes s'adressent exclusivement à un personnel qualifié. Il est également indispensable de se reporter aux consignes de sécurité précédentes. Toute intervention interne ou réglage doit s'effectuer en présence d'une autre personne capable d'assurer les premiers secours en cas de danger.

Agir avec précaution lorsque l'appareil est sous tension

Des potentiels dangereux existent en différents points de l'appareil. Pour éviter toute blessure, ne pas intervenir sur les connexions et les composants alors que l'appareil est sous

tension. Débrancher l'alimentation avant le démontage des panneaux, soudure ou remplacement de composants.

Source d'alimentation

Cet appareil est conçu pour fonctionner à partir d'une source d'alimentation qui n'applique pas plus de 250 V efficaces entre les conducteurs d'alimentation ou entre un conducteur et la masse. Pour utiliser l'appareil en toute sécurité, une connexion à la masse réalisée au moyen d'un conducteur prévu dans le cordon d'alimentation est indispensable.

SICHERHEITSANGABEN FÜR DEN ANWENDER

Die allgemeinen Sicherheitsinformationen in diesem Teil der Angaben dienen dem Anwender- und Servicepersonal. Spezielle Warnungen und Hinweise sind überall im Handbuch zu finden, müssen jedoch in diesen Angaben nicht erscheinen.

BEGRIFFE

In diesem Handbuch

VORSICHTSHINWEISE erläutern Bedingungen, die zur Zerstörung des Gerätes oder anderer Gegenstände führen können.

WARNUNGSHINWEISE erläutern Bedingungen, die zu Personenschäden führen können oder lebensgefährlich sind.

Markierungen auf dem Gerät

CAUTION - VORSICHT weist darauf hin, daß durch zufälliges Berühren an einer nicht unmittelbar zugänglichen Stelle Personenschaden entstehen kann, oder Schaden am Gerät selbst.

DANGER - GEFAHR weist darauf hin, daß durch zufälliges Berühren an einer zugänglichen Stelle Personenschaden entstehen kann.

Vermeidung von elektrischen Schlägen vor der Beschaltung der Ein- und Ausgänge ist der Netzstecker in eine korrekt verdrahtete Steckdose einzustecken. Verwenden Sie den Schutzleiter nicht als einzige Verbindung zwischen zwei oder mehreren Geräten. Zur Vermeidung von elektrischen Schlägen sind die Geräte untereinander mit separaten Leitungen zu verbinden.

Gefahr durch fehlende Schutz Erde

Durch eine fehlende Schutz Erde können alle berührbaren, leitenden Teile (einschließlich Knöpfe und andere Bedienungselemente, die isoliert sind) einen elektrischen Schlag bei der Berührung auslösen.

Verwendung eines richtigen Netzkabels

Verwenden Sie nur Netzkabel, die für die Versorgungseinheit geeignet sind und die sich in gutem Zustand befinden.

Für detaillierte Informationen über Kabel und Stecker beziehen Sie sich bitte auf Abbildungen innerhalb des Handbuches.

Ein Austausch von Kabeln und Steckern ist nur von geschultem Personal vorzunehmen.

SYMBOLE

In diesem Handbuch



Dieses Symbol zeigt an, wo Vorsicht walten zu lassen ist, oder wo Informationen zu finden sind.

Markierungen auf dem Gerät



GEFAHR - Hochspannung.



Schutzerdungskontakt.



ACHTUNG - beziehen Sie sich auf das Handbuch.

Netzspannungsversorgung

Die Betriebsspannung für dieses Gerät darf 250 V_{eff} nicht überschreiten und ist an die Versorgungsleitungen bzw. an eine Versorgungsleitung und Masse anzulegen. Innerhalb des Netzanschlußkabels muß ein Schutzleiter vorhanden sein, der mit Gerätemasse verbunden ist.

Masseanschluß des Gerätes

Dieses Gerät wird über den Schutzleiter der Versorgungseinheit mit Erdpotential verbunden. Zur Vermeidung

Verwendung einer richtigen Sicherung

Zur Vermeidung von Brandschäden sind nur Sicherungen zu verwenden, die in den Teilleisten dieses Gerätes aufgeführt sind und die in Spannungs- und Stromwert entsprechend sind.

Ersatz von Sicherungen ist nur von geschultem Personal vorzunehmen.

Arbeiten Sie nicht in explosiver Umgebung

Zur Vermeidung von Explosionen ist die Inbetriebnahme dieses Gerätes in explosiver Umgebung zu unterlassen, wenn das Gerät nicht dafür geeignet ist.

Entfernen Sie keine Gehäuseabdeckungen

Zur Vermeidung von Personenschäden sind keine Gehäuseteile zu entfernen. Auch ist das Gerät ohne Gehäuse nicht in Betrieb zu nehmen.

Arbeiten Sie nicht ohne Gehäuseabdeckung

Zur Vermeidung von Personenschäden ist das Gerät nicht ohne Gehäuse in Betrieb zu nehmen. Der Einschub sollte nicht über einen Verlängerungsadapter betrieben werden.

SICHERHEITSAANGABEN FÜR DEN SERVICE

NUR FÜR GESCHULTES PERSONAL

Beziehen Sie sich auch auf die vorangehenden Sicherheitsangaben für den Anwender.

Führen Sie keine Servicetätigkeiten alleine durch

Nehmen Sie an dem Gerät keine Service- oder Einstellarbeiten vor, wenn nicht eine andere Person verfügbar ist, um im Bedarfsfall Erste Hilfe oder Wiederbelebungsversuche zu leisten.

Lassen Sie besondere Vorsicht walten, wenn Sie an einem unter Spannung stehenden Gerät arbeiten

An verschiedenen Stellen im Gerät liegen hohe und damit gefährliche Spannungen. Zur Vermeidung von Personen-

schäden sind solche Stellen und Bauteile nicht zu berühren, während Betriebsspannung anliegt.

Vor dem Entfernen von Gehäuseteilen, Löten oder Ersetzen von Bauteilen ist immer die Betriebsspannung zu entfernen.

Netzspannungsversorgung

Die Betriebsspannung für dieses Gerät darf $250 V_{eff}$ nicht überschreiten und ist an die Versorgungsleitungen bzw. an eine Versorgungsleitung und Masse anzulegen. Innerhalb des Netzanschlußkabels muß ein Schutzleiter vorhanden sein, der mit Gerätemasse verbunden ist.

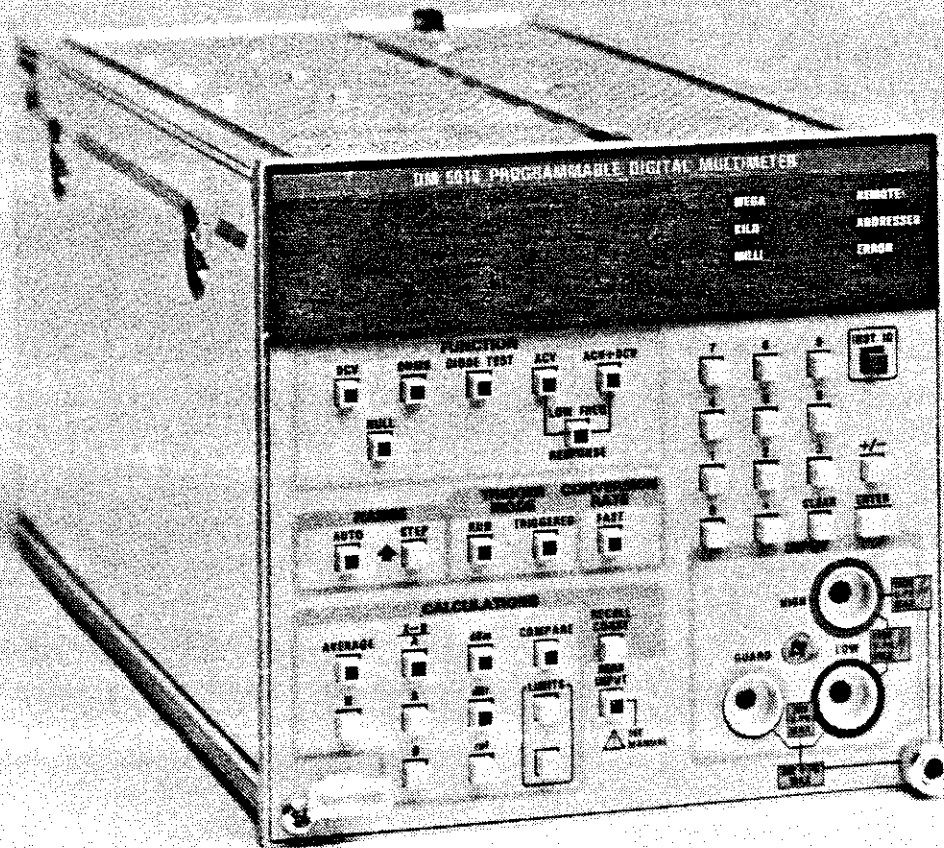

2994-00

DM 5010 Programmable Digital Multimeter.

SPECIFICATION

Introduction

The TEKTRONIX DM 5010 Programmable Digital Multimeter is a TM 5000 plug-in designed to operate in two compartments of a TM 5000-Series power module. The DM 5010 measures and displays dc voltages, resistance, true rms ac voltages, and true rms ac + dc voltages. Range selection is automatic or manually incremented. A diode test function provides a 1 mA current output for diode testing. Measurements are made via front-panel connectors or a rear-interface connector.

The DM 5010 also performs calculations for averaging, scale and offset, conversion to dBm or reference dB, and comparison. Measurements and calculation results are indicated on a signed 4 1/2 digit LED display. The decimal point is automatically positioned and leading zeros are blanked.

The operation of the DM 5010 is programmable via high-level commands (ASCII) sent over the IEEE 488 digital interface. The DM 5010 can send information about front panel control settings, measurements, and calculations via the bus to a GPIB controller. Measurements and calculations are triggered by internal circuitry (at a normal or a fast rate), front-panel push button, GPIB command, or external signal via a rear-interface connector.

This instrument is listed with Underwriters Laboratories, Inc. under U.L. Standard 1244 (Electrical and Electronic Measuring and Testing Equipment).

Standard Accessories

- 1 Instruction Manual
- 1 Test Lead Set
- 1 Reference Guide

Refer to the Accessories page at the back of this manual for part numbers.

IEEE 488 (GPIB) Functions

The DM 5010 can be remotely programmed via the digital interface specified in IEEE Standard 488-1978, *IEEE Standard Digital Interface for Programmable Instrumentation*. In this manual, the digital interface is called the General Purpose Interface Bus (GPIB).

The IEEE standard identifies the interface function repertoire of an instrument on the GPIB in terms of interface function subsets. The subsets are defined in the standard. The subsets listed in Table 1-1 apply to the DM 5010.

Table 1-1
IEEE 488 INTERFACE FUNCTION SUBSETS

| Function | Subset | Capability |
|--------------------|--------|--|
| Source Handshake | SH1 | Complete. |
| Acceptor Handshake | AH1 | Complete. |
| Basic Talker | T5 | Responds to Serial Poll. Untalks if My Listen Address (MLA) is received. Talk Only capability. |
| Basic Listener | L4 | Unlistens if My Talk Address (MTA) is received. |
| Service Request | SR1 | Complete. |
| Remote-Local | RL1 | Complete. |
| Parallel Poll | PP0 | Does not respond to Parallel Poll. |
| Device Clear | DC1 | Complete. |
| Device Trigger | DT1 | Complete. |
| Controller | C0 | No controller function. |

Performance Conditions

The limits stated in the Performance Requirements column of the following tables are valid with the following conditions:

1. The instruments internal adjustments are performed at an ambient temperature between +21°C and +25°C.
2. The instrument must be in a non-condensing environment whose limits are described under Environmental.
3. Allow thirty minutes warm-up time for operation to specified accuracy; sixty minutes after exposure to or storage in high-humidity (condensing) environment.

Items listed in the Performance Requirements column of the Electrical Characteristics are verified by completing the

Specification—DM 5010

Performance Check in this manual. Information given in the Supplemental Information and Description columns of the following tables is provided for user information only and should not be interpreted to be Performance Check requirements. The information under Electrical Characteristics applies to both front-panel and rear-interface measurements, unless otherwise noted.

NOTE

For measurements to specified accuracy, internal adjustments should be performed after 1000 hours of operation or every six months if used infrequently. Refer to the Adjustment Procedure in this manual.

**Table 1-2
ELECTRICAL CHARACTERISTICS**

| Characteristics | Performance Requirements | Supplemental Information |
|---|---|---|
| DC VOLTS | | |
| ACCURACY for the 200 mV, 2 V, 20 V, 200 V, and 1000 V ranges: | | |
| Normal Conversion Rate | | (3 readings per second) |
| +18°C to +28°C | | |
| 200 mV range | ±(0.015% of reading + 0.01% of full scale) | |
| 2 V through 200 V ranges | ±(0.015% of reading + 0.005% of full scale) | |
| 1000 V range | ±(0.020% of reading + 0.010% of full scale) | |
| 0°C to +18°C, +28°C to +50°C | | For the typical accuracy for a given temperature in this range, add to the +18°C to +28°C accuracy, ±(0.002% of reading + 0.001% of full scale)/°C deviation from +28°C or +18°C. |
| 200 mV range | ±(0.06% of reading + 0.035% of full scale) | |
| 2 V through 200 V ranges | ±(0.06% of reading + 0.03% of full scale) | |
| 1000 V range | ±(0.065% of reading + 0.035% of full scale) | |
| Fast Conversion Rate | | (26 readings per second) |
| +18°C to +28°C | | |
| 200 mV to 200 V ranges | ±(0.05% of reading + 0.05% of full scale) | |
| 1000 V range | ±(0.05% of reading + 0.1% of full scale) | |
| 0°C to +18°C, +28°C to +50°C | | |
| 200 mV to 200 V ranges | ±(0.1% of reading + 0.1% of full scale) | |
| 1000 V range | ±(0.1% of reading + 0.15% of full scale) | |

Table 1-2 (cont)

| Characteristics | Performance Requirements | Supplemental Information |
|---|--|--|
| DC VOLTS (cont) | | |
| TRUE COMMON MODE REJECTION (CMR) | | Verified with 1 k Ω unbalance in either terminal. |
| Unguarded | ≥ 130 dB at dc. ≥ 80 dB at 50 to 60 Hz | |
| Guarded | ≥ 140 dB at dc ≥ 100 dB at 50 to 60 Hz | |
| NORMAL MODE REJECTION RATIO (NMRR) | | |
| Normal Conversion Rate | ≥ 40 dB at 50 or 60 Hz, ± 0.2 Hz | |
| Fast Conversion Rate | ≥ 40 dB at 50 Hz, ± 0.2 Hz ≥ 40 dB at 60 Hz, ± 0.2 Hz | (50/60 Hz jumper in 50 Hz position) (50/60 Hz jumper in 60 Hz position) |
| MAXIMUM RESOLUTION | | 10 μ V |
| INPUT RESISTANCE | | |
| 200 mV—20 V ranges | | $> 10^9 \Omega$ |
| 200 V—1000 V ranges | | $10^7 \Omega$, $\pm 0.25\%$ |
| STEP RESPONSE TIME (To rated accuracy) | | |
| RUN Mode | | |
| Normal Conversion Rate | | ≤ 0.53 sec |
| Fast Conversion Rate | | ≤ 0.08 sec |
| TRIGGERED Mode | | |
| Normal Conversion Rate | | ≤ 0.33 sec |
| Fast Conversion Rate | | ≤ 0.06 sec |
| MAXIMUM INPUT VOLTAGE | | |
| Front Panel Connectors | | |
| HIGH to LOW or HIGH to Chassis | | 1000 V peak |
| LOW to Chassis or GUARD to Chassis | | 350 V peak |
| GUARD to LOW | | 200 V peak |
| Rear Interface Connector | | |
| Pin 28B (Hi) to pin 28A (Lo) | | 60 V (dc plus pk ac) |

Table 1-2 (cont)

| Characteristics | Performance Requirements | Supplemental Information |
|---|---|--|
| AC VOLTS—TRUE RMS | | |
| <p>ACCURACY for the 200 mV, 2 V, 20 V, 200 V, and 700 V ranges: (sinewave AC) (Input signal between 5% and 100% of full scale except 700 V range ($100\text{ V} < V_m < 700\text{ V}$)).</p> <p>Normal and Fast Conversion Rates</p> | | (3 and 26 readings per second) |
| <p>ACV+DCV Function (DC only or DC component >10% of AC Component.)</p> <p>+18°C to +28°C</p> <p>200 mV Range</p> <p>2 V, 20 V Ranges</p> <p>200 V, 700 V Ranges</p> | <p>$\pm (.2\% \text{ of reading} + .55\% \text{ of full scale})$</p> <p>$\pm (.2\% \text{ of reading} + .2\% \text{ of full scale})$</p> <p>$\pm (.2\% \text{ of reading} + .5\% \text{ of full scale})$</p> | |
| <p>0°C to +18°C</p> <p>+28°C to +50°C</p> <p>200 mV Range</p> <p>2 V, 20 V Ranges</p> <p>200 V, 700 V Ranges</p> | <p>$\pm (.45\% \text{ of reading} + 1.3\% \text{ of full scale})$</p> <p>$\pm (.45\% \text{ of reading} + .4\% \text{ of full scale})$</p> <p>$\pm (.45\% \text{ of reading} + .95\% \text{ of full scale})$</p> | <p>For the typical accuracy for a given temperature in this range, add to the +18°C to +28°C accuracy the following tolerance, per degree deviation from +18°C or +28°C.</p> <p>$\pm (.009\% \text{ of reading} + .025\% \text{ of full scale})/^{\circ}\text{C}$</p> <p>$\pm (.009\% \text{ of reading} + .007\% \text{ of full scale})/^{\circ}\text{C}$</p> <p>$\pm (.009\% \text{ of reading} + .015\% \text{ of full scale})/^{\circ}\text{C}$</p> |
| <p>ACV+DCV Function (DC component <10% of AC Component.)</p> <p>10 Hz to 20 Hz (using LOW FREQ RESPONSE)</p> <p>+18°C to +28°C</p> <p>200 mV through 200 V Ranges</p> <p>700 V Range</p> | <p>$\pm (.8\% \text{ of reading} + .3\% \text{ of full scale})$</p> <p>$\pm (.8\% \text{ of reading} + .9\% \text{ of full scale})$</p> | |
| <p>0°C to +18°C</p> <p>+28°C to +50°C</p> <p>200 mV through 200 V Ranges</p> <p>700 V Range</p> | <p>$\pm (1.25\% \text{ of reading} + .45\% \text{ of full scale})$</p> <p>$\pm (1.25\% \text{ of reading} + 1.25\% \text{ of full scale})$</p> | <p>For the typical accuracy for a given temperature in this range, add to the +18°C to +28°C accuracy the following tolerance, per degree deviation from +18°C or +28°C.</p> <p>$\pm (0.02\% \text{ of reading} + 0.005\% \text{ of full scale})/^{\circ}\text{C}$</p> <p>$\pm (0.02\% \text{ of reading} + 0.015\% \text{ of full scale})/^{\circ}\text{C}$</p> |

Table 1-2 (cont)

| Characteristics | Performance Requirements | Supplemental Information |
|---|---|---|
| AC VOLTS—TRUE RMS (cont) | | |
| ACV and ACV+DCV (DC Component <10% of AC Component) +18°C to +28°C | | |
| 200 mV through 200 V ranges | | |
| 20 Hz to 100 Hz | $\pm(0.8\% \text{ of reading} + 0.2\% \text{ of full scale})$ | |
| 100 Hz to 20 kHz | $\pm(0.2\% \text{ of reading} + 0.2\% \text{ of full scale})$ | |
| 20 kHz to 100 kHz | $\pm(1.0\% \text{ of reading} + 0.5\% \text{ of full scale})$ | Subject to $10^7 \text{ V} \cdot \text{Hz}$ maximum |
| 700 V range | | |
| 20 Hz to 100 Hz | $\pm 0.8\% \text{ of reading} + 0.6\% \text{ of full scale})$ | |
| 100 Hz to 15 kHz | $\pm(0.2\% \text{ of reading} + 0.6\% \text{ of full scale})$ | |
| 0°C to +18°C +28°C to +50°C | | For the typical accuracy for a given temperature in this range, add to the +18°C to +28°C accuracy the following tolerance, per degree deviation from +18°C or +28°C. |
| 200 mV through 200 V ranges | | |
| 20 Hz to 100 Hz | $\pm(1.25\% \text{ of reading} + 0.35\% \text{ of full scale})$ | $\pm(0.02\% \text{ of reading} + 0.005\% \text{ of full scale})/^\circ\text{C}$. |
| 100 Hz to 20 kHz | $\pm(0.65\% \text{ of reading} + 0.3\% \text{ of full scale})$ | $\pm(0.2\% \text{ of reading} + 0.005\% \text{ of full scale})/^\circ\text{C}$. |
| 20 kHz to 100 kHz | $\pm(1.45\% \text{ of reading} + 0.65\% \text{ of full scale})$ | $\pm(0.02\% \text{ of reading} + 0.005\% \text{ of full scale})/^\circ\text{C}$. |
| 700 V range | | |
| 20 Hz to 100 Hz | $\pm(1.25\% \text{ of reading} + 0.95\% \text{ of full scale})$ | $\pm(0.02\% \text{ of reading} + 0.015\% \text{ of full scale})/^\circ\text{C}$. |
| 100 Hz to 15 kHz | $\pm(0.65\% \text{ of reading} + 0.95\% \text{ of full scale})$ | $\pm(0.02\% \text{ of reading} + 0.015\% \text{ of full scale})/^\circ\text{C}$. |
| MAXIMUM RESOLUTION | | 10 μV |
| STEP RESPONSE TIME (To rated accuracy) | | <1.2 sec, except for LOW FREQ RESPONSE |
| INPUT IMPEDANCE | | 2 M Ω , $\pm 0.1\%$ paralleled by <150 pF |
| MAXIMUM INPUT VOLTAGE | | |
| Front-Panel Connectors HIGH to LOW, or HIGH to Chassis | | 1 kV peak (500 Vdc maximum in ACV mode) |
| LOW to Chassis, or GUARD to Chassis | | 350 V peak |

Table 1-2 (cont)

| Characteristics | Performance Requirements | Supplemental Information |
|--|---|---|
| AC VOLTS—TRUE RMS | | |
| GUARD to LOW | | 200 V peak |
| Rear Interface Connector Pin 28B (HI) to pin 28A (LO) | | 60 V (dc plus pk ac) |
| CREST FACTOR | | 4 (subject to maximum peak input voltage) |
| MAXIMUM VOLT • Hz PRODUCT | | 10^7 V • Hz |
| TRUE COMMON MODE REJECTION (CMR) | | With 1 k Ω unbalance in either terminal |
| Unguarded | | Typically ≥ 80 dB from dc to 60 Hz |
| Guarded | | Typically ≥ 100 dB from dc to 60 Hz |
| OHMS | | |
| ACCURACY for the 200 Ω , 2 k Ω , 20 k Ω , 200 k Ω , 2 M Ω , and 20 M Ω ranges: | | |
| Normal Conversion Rate | | (1.6 readings per second) |
| +18°C to +28°C | | |
| 200 Ω range | $\pm(0.015\%$ of reading + 0.015% of full scale) ^a | |
| 2 k Ω to 200 k Ω ranges | $\pm(0.015\%$ of reading + 0.01% of full scale) ^b | |
| 2 M Ω range | $\pm(0.10\%$ of reading + 0.01% of full scale) | |
| 20 M Ω range | $\pm(0.15\%$ of reading + 0.005% of full scale) | |
| 0°C to +18°C, +28°C to +50°C | | For the typical accuracy for a given temperature in this range, add to the +18°C to +28°C accuracy the following tolerance, per degree deviation from +18°C or +28°C. |
| 200 Ω range | $\pm(0.06\%$ of reading + 0.06% of full scale) ^a | |
| 2 k Ω to 200 k Ω ranges | $\pm(0.06\%$ of reading + 0.035% of full scale) ^b | $\pm(0.002\%$ of reading + 0.001% of full scale)/°C |
| 2 M Ω range | $\pm(0.54\%$ of reading + 0.035% of full scale) | $\pm(0.02\%$ of reading + 0.001% of full scale)/°C |
| 20 M Ω range | $\pm(0.9\%$ of reading + 0.01% of full scale) | $\pm(0.034\%$ of reading + 0.0001% of full scale)/°C |

a. Using NULL
 b. Using NULL on 2k OHM range only.
 c. Using NULL on 200 OHM range only.
 When the NULL function is not used, add ± 200 milliohms to all readings.

Table 1-2 (cont)

| Characteristics | Performance Requirements | Supplemental Information |
|--|--------------------------|--|
| OHMS (cont) | | |
| MAXIMUM OPEN CIRCUIT VOLTAGE | | <5 volts |
| MEASURING FULL SCALE VOLTS | | |
| 200 Ω through 2 MΩ ranges | | 0.2 V max |
| 20 MΩ range | | 0.8 V max |
| REAR INTERFACE OFFSET | | |
| Ohms offset to rear interface input connector pins | -0.5 Ω to -0 Ω | Subtract offset from measurements, or use NULL feature to eliminate offset for ohms measurements via the rear interface. |
| DIODE TEST | | |
| ACCURACY | | With a 604 Ω, ±1% resistor connected between the HIGH and LOW input connectors, the display should read between 0.5484 Vdc and 0.6054 Vdc. |
| MAXIMUM OPEN CIRCUIT VOLTAGE | | <5 volts |

Table 1-3
MISCELLANEOUS

| Characteristics | Description |
|---------------------------------|--|
| POWER CONSUMPTION | 20 VA or less |
| RECOMMENDED ADJUSTMENT INTERVAL | 1000 hours or 6 months |
| WARM-UP TIME | 30 minutes (60 minutes after storage in high humidity environment) |
| OVER-RANGE INDICATION | For OHMS or DIODE TEST function, OC is displayed; for ACV, DCV, or ACV+DCV, the display flashes. |

**Table 1-4
ENVIRONMENTAL***

| Characteristics | Description |
|---|--|
| TEMPERATURE Operating Non-operating | 0°C to +50°C -20°C to +65°C Meets MIL-T-28800B, class 5. Class 5 non-operating temperature exception due to internal keep-alive battery. |
| HUMIDITY | 95% RH, 0°C to 30°C 75% RH, to 40°C 45% RH, to 50°C Exceeds MIL-T-28800B, class 5. |
| ALTITUDE Operating Non-operating | 4.6 km (15,000 ft.) 15 km (50,000 ft.) Exceeds MIL-T-28800B, class 5. |
| VIBRATION ^b | 0.38 mm (0.015") peak to peak, 5 Hz to 55 Hz, 75 minutes Meets MIL-T-28800B, class 5, when installed in qualified power module. ^c |
| SHOCK ^b | 30 g's (1/2 sine) 11 ms duration, 3 shocks in each direction along 3 major axes, 18 total shocks. Meets MIL-T-28800B, class 5, when installed in qualified power module. ^c |
| BENCH HANDLING ^d | 12 drops from 45°, 4" or equilibrium, whichever occurs first. Meets MIL-T-28800B, class 5, when installed in qualified power module. ^c |
| TRANSPORTATION ^d | Qualified under National Safe Transit Association Preshipment Test Procedures 1A-B-1 and 1A-B-2. |
| EMC ^e | Within limits of F.C.C. Regulations, Part 15, Sub-part J, Class A; VDE 0871; and MIL 461A test RE01, RE02, CE01, CE03, RS01, RS03, CS01, and CS02. |
| ELECTRICAL DISCHARGE | 20 kV maximum charge applied to instrument case. |

*With power module.

^bRequires retainer clip.

^cRefer to TM 5000-Series power module specifications.

^dWithout power module.

^eSystem performance subject to exceptions of power module or other individual plug-ins.

Table 1-5
PHYSICAL CHARACTERISTICS

| Characteristics | Description |
|----------------------------|---|
| FINISH | Plastic-aluminum laminate front panel. |
| NET WEIGHT | 4.5 lbs (2.04 kg) |
| ENCLOSURE TYPE AND STYLE | MIL-T-28800B, type 3, style E package with power module. (Style F in rackmount power module.) |
| NOMINAL OVERALL DIMENSIONS | |
| Height | 126.01 mm (4.96 in.) |
| Width | 134.47 mm (5.29 in.) |
| Length | 288.34 mm (11.35 in.) |

OPERATING INSTRUCTIONS

Introduction

This section of the manual provides installation and removal instructions and describes the functions of the DM 5010 front-panel controls and connectors. Operators familiarization information is also provided as an aid in understanding how to operate the DM 5010 under local (manual) control only. The information in this section assumes the instrument is not connected to the GPIB via the power module.

Complete information for programming the DM 5010 via the GPIB (General Purpose Interface Bus) is found in the Programming section of this manual.

PREPARATION FOR USE

Installation and Removal

CAUTION

Upon receipt of the instrument, the DM 5010 should be powered up continuously for approximately 24 hours to ensure that its internal keep-alive battery remains sufficiently charged. Failure to do so can result in faulty operation due to loss of calibration factors stored in memory. Calibration factors are restored to memory by performing the Adjustment Procedure in this manual.

NOTE

The DM 5010 is designed to operate only in a TM 5000-Series power module. Refer to the power module instruction manual before installing the DM 5010.

The DM 5010 is calibrated and ready for use when received. Make certain that the line selector block on the power module is positioned correctly. In addition, the DM 5010 contains an internal line frequency select jumper. For best rejection of line frequency related noise when the instrument is operating at the FAST CONVERSION RATE, this jumper position should match the line frequency supplied to the power module. The instrument is shipped with the jumper

positioned for a 60 Hz line frequency. For jumper placement, refer qualified service personnel to the Maintenance section of this manual for additional information.

CAUTION

To prevent damage to the DM 5010, turn off the power module before installing or removing the instrument. Do not use excessive force to install or remove.

Check to see that the plastic barriers on the interconnecting jacks of the selected power module compartments match the cutouts in the DM 5010 rear-interface connectors. If they do not match, do not install the DM 5010 until the reason is investigated. When the units are properly matched, align the DM 5010 chassis with the upper and lower guides of the selected compartments (see Fig. 2-1). Push the DM 5010 chassis in and press firmly to seat the rear-interface connectors in the interconnecting jacks. Apply power to the DM 5010 by operating the power switch on the power module.

To remove the DM 5010 from the power module, pull out on the release latch (located in the lower left corner) until the interconnecting jacks disengage and the DM 5010 slides out.

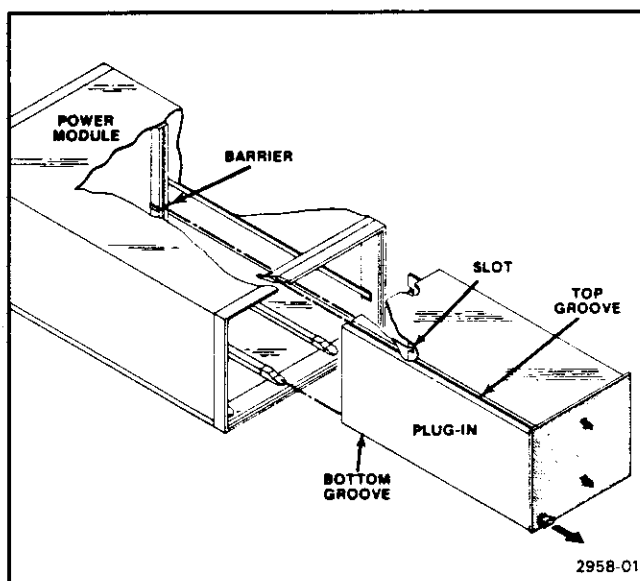

Fig. 2-1. Plug-in installation and removal.

FRONT PANEL CONTROLS AND CONNECTORS

General Information

The seventeen front-panel push buttons listed below enable their functions and illuminate when pressed. The push buttons in the left column are self-cancelling; that is, only one push button is active (illuminated) at a time. The push buttons in the right column illuminate when activated, and remain illuminated and active until pressed again.

| | |
|------------|-------------------|
| DCV | NULL |
| OHMS | LOW FREQ RESPONSE |
| DIODE TEST | AUTO |
| ACV | RUN |
| ACV + DCV | TRIGGERED |
| | FAST |
| | AVERAGE |
| | X-B |
| | A |
| | dBm |
| | dBr |
| | COMPARE |
| | REAR INPUT |

The remaining twenty-three are non-illuminating push buttons that activate their associated functions. Refer to Fig. 2-2.

Display Window

The left side of the window displays measurements and calculation results using signed 4 1/2 digit LEDs. Zeros leading the decimal are suppressed. A flashing display indicates over-range when the voltage measurement functions are active; OC is displayed for OHMS and DIODE TEST.

The center area of the window indicates the range multiplier for the displayed reading. Illuminated LED associated with the words MILLI, KILO, and MEGA on the window indicate when the displayed measurement is in milli, kilo, or mega units. The decimal point is fixed for each function range. The multiplier LED and decimal point location indicate the range for both AUTO and manual (STEP) methods of range selection. See Fig. 2-2.

The right area of the display window indicates the operating state of the instrument, as follows:

REMOTE and ADDRESSED illuminate only when the instrument is operating under remote program control via the GPIB.

ERROR illuminates when an internal error, self test error, or operating error occurs. The left area of the window also displays front panel error codes indicating the type of error. See Table 2-2 in Operators Familiarization in this section of the manual.

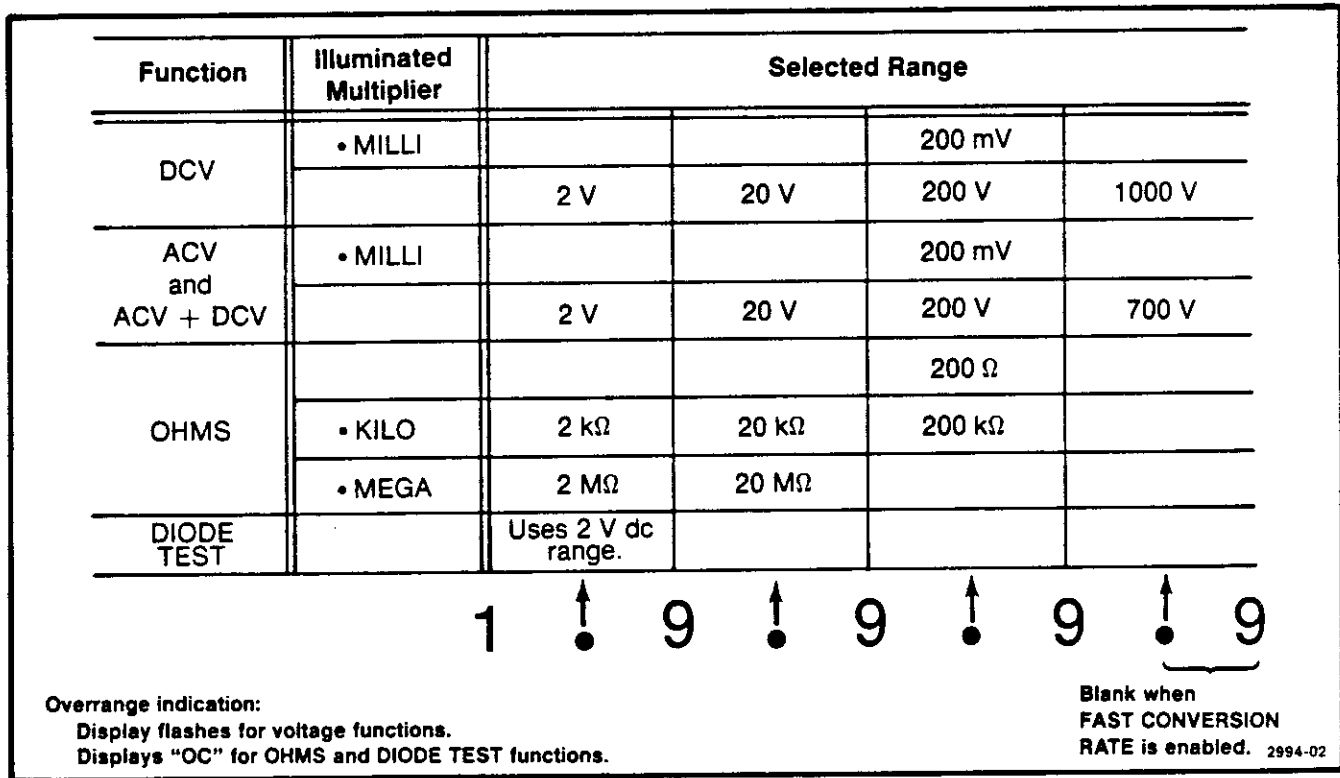
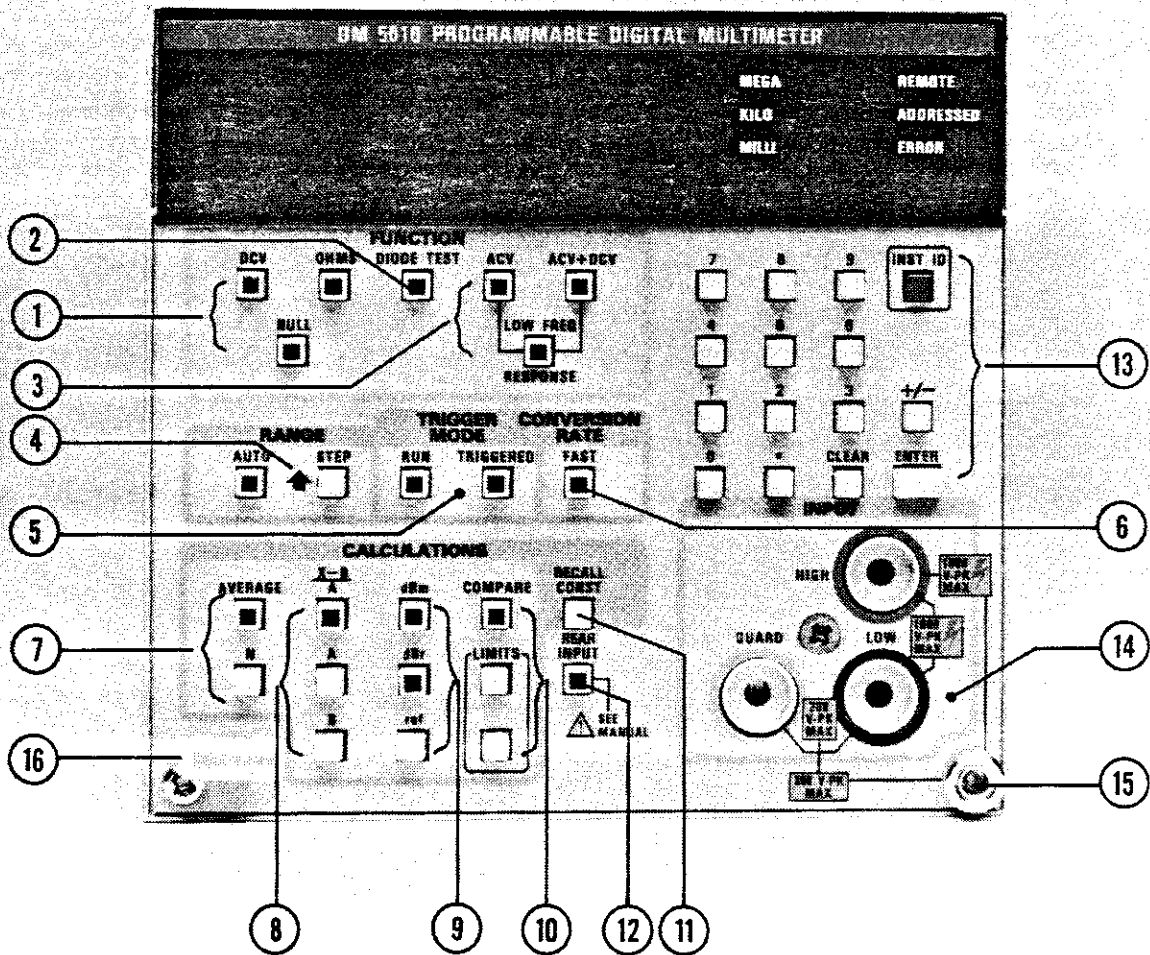

Fig. 2-2. DM 5010 front panel range indication.



2994-03

Fig. 2-3. DM 5010 front panel controls and connectors.

Controls and Connectors

The following list describes the functions of the DM 5010 front-panel controls and connectors. See Fig. 2-3.

FUNCTIONS

①

DCV

When this button is illuminated, the DM 5010 measures dc voltages applied to the front-panel or rear-interface input connectors. The range used with this function are: 200 mV, 2 V, 20 V, 200 V, and 1000 V.

OHMS

Illuminating this button selects the resistance measurement mode. Resistances applied to the front-panel input connectors or the rear-interface input connections are measured using the 200 Ω , 2 k Ω , 20 k Ω , 200 k Ω , 2 M Ω , and 20 M Ω ranges.

NULL

This function operates with the DM 5010 set to DCV, OHMS, DIODE TEST, ACV, or ACV+DCV (any range). When the NULL button is illuminated, the instrument measures and stores the value of resistance or voltage across the front-panel or rear-interface input connectors. This stored offset is applied to the subsequent measurements and the results displayed. The value of the offset may be up to $\pm 100\%$ of the range. When the function in use is changed or NULL function disabled (NULL button pressed), the NULL offset is no longer applied. The stored offset is retained until a new offset is set by nulling or until the function in use at the time of nulling is changed.

WARNING

Use caution when the NULL function is enabled, since the displayed measurement may not indicate the value of the voltage applied to the input connectors.

②

DIODE TEST

Illuminating this button generates a 1 mA dc current at the front panel or rear interface high input connector. Using conventional current flow, this current flows out the high input connector, through a component connected between the high and low connectors and into the low connector. The voltage developed across the component is measured and displayed using the 2 V dc range.

③

ACV

When this button is illuminated, the DM 5010 measures and displays true rms ac voltages. Applied voltages are internally ac coupled to a rms convert-

er. The ranges used with this function are: 200 mV, 2 V, 20 V, 200 V, and 700 V.

ACV+DCV

When this button is illuminated, the DM 5010 measures and displays true rms ac voltages elevated to a dc voltage level. Applied voltages are internally dc coupled to the rms converter. The ranges used are: 200 mV, 2 V, 20 V, 200 V, and 700 V.

LOW FREQ RESPONSE

When this button is illuminated and the ACV or ACV+DCV function is active, the instrument averages 4 measurements and displays the average value of these measurements. This sequence then repeats. The function provides a stable readout when measuring low-frequency ac voltages. It is specified down to 10 Hz; however, it is usable over the entire frequency range specified for the DM 5010.

RANGE

④

AUTO

When this button is illuminated, range selection is automatic. At over-range, the DM 5010 switches to the next higher range. If the measured value is less than 9.5% of the range (for most ranges), the instrument switches to the next lower range.

STEP

Activating this button causes the DM 5010 to increment one range. The range is maintained until the AUTO button is pressed to activate automatic range selection or until the range is again incremented. The range is maintained when the function (DCV, OHMS, DIODE TEST, ACV, ACV+DCV) is changed, except a change to the OHMS function selects the highest range. Incrementing while operating in the highest range selects the lowest range.

TRIGGER MODE

⑤

RUN

When this button is illuminated, conversions are free-running at the selected rate. For conversion rate selection, refer to FAST.

TRIGGERED

Illuminating this button triggers and displays one measurement. The next measurement begins when this function is again activated (button is pressed, or EXTRIG trigger signal is received). Use of the EXTRIG triggering requires installation of an internal jumper by qualified service personnel. The TRIGGERED button flashes on briefly when the instrument is triggered.

CONVERSION RATE

- ⑥ **FAST**
With this button illuminated, the conversion (reading) rate is the maximum rate specified for the selected measurement function. At this conversion rate, resolution is 3.5 digits.

When the FAST button is not illuminated, conversions occur at the normal reading rate specified for the selected measurement function. Results are displayed using 4.5 digits.

- ⑦ **AVERAGE**
Illuminating this button causes the DM 5010 to calculate the average of a series of readings. The value of the N constant determines how many readings are averaged in the series. To calculate the average, the instrument sums the measured values for the series of readings and divides the sum by the number of readings in the series. If LOW FREQ RESPONSE is also active, the number of measurements averaged is four times the value of the N constant. When operating in the TRIGGERED mode, only one trigger is required to initiate all the measurements used in the AVERAGE calculation.

N
This button is used to store or recall a constant used in the AVERAGE calculation. The constant determines how many measurements are averaged. At instrument power-up, the value of N is set to 2. This value can be changed to any positive integer ≥ 1 and ≤ 19999 .

- ⑧ **X-B**
A
Illuminating this button causes the DM 5010 to subtract a stored offset constant from a measurement, divide the result by a stored scale constant, and display the result. The offset constant is B, the scale constant is A, and X is the measurement.

A, B
These buttons are used to store or recall constants used in the X-B/A calculation. At instrument power-up, the value of A is set to 1 and the value of B is set to 0. These constants can be changed to any number (integer, decimal, positive or negative) except that the value of A cannot be 0.

- ⑨ **dBm**
When this button is illuminated, the DM 5010 calculates and displays the power ratio of a voltage measurement referenced to 1 mW and 600 Ω (.7746 V), using the formula:

$$dBm = 20 \log_{10} \left| \frac{x_1}{\sqrt{.6}} \right|$$

where x_1 is the voltage measurement. The logarithm of the absolute value of $x_1/\sqrt{.6}$ is taken.

dBr
When this button is illuminated, the DM 5010 calculates and displays the logarithmic ratio of a measurement to the constant stored for the ref button, using the formula:

$$dBr = 20 \log_{10} \left| \frac{x_1}{ref} \right|$$

where x_1 is the measurement. The logarithm of the absolute value of x_1/ref is taken.

ref
This button is used to store or recall a constant used in the dBr calculation. At instrument power-up, the value of ref is set to 1. The value of ref can be any number except 0.

- ⑩ **COMPARE**
Activating this calculation (button illuminated) causes the DM 5010 to compare the next reading with limits set by LIMITS constants. If the compared reading is algebraically less than both constants, the word LO is displayed. The word HI is displayed if the reading is algebraically greater than both constants. PASS is displayed if the reading is equal to or between the constants.

LIMITS (2)
These buttons are used to store or recall constants used as limits in the COMPARE calculation. The values of the constants are set to 0 at instrument power-up.

- ⑪ **RECALL CONST**
Pressing this button and then one of the constant buttons (N, A, B, ref, LIMITS) causes the instrument to display the value stored for that constant.

- ⑫ **REAR INPUT** 
See Rear Interface Measurements under Operators Familiarization in this section of the manual. Illuminating this button selects rear-interface inputs instead of front-panel inputs.

- ⑬ **DIGITS (0 through 9), Decimal Point, and Sign**
These buttons are used for entering numerals, decimals, and polarity for storing constants.

CLEAR
When an error code is displayed in the display window, activating this button clears the displayed error code. Also, when entering a constant, activating the CLEAR button clears from the display window a constant value that has not yet been entered.

ENTER
When entering a constant, activating this button stores the number for the selected constant and displays the stored constant value.

INST ID

Activating this button causes the instrument to display its primary address and, if USEREQ has been enabled, generate a Service Request (SRQ) on the GPIB. Also, the minus sign lights if Talk Only mode is enabled and the far right decimal point lights if LF/EOI message terminator is selected; decimal does not light for EOI ONLY selection.

INPUT

14 HIGH Connector

Isolated analog high connector used with LOW and GUARD connectors for all front panel measurements.

LOW Connector

Isolated analog low connector used with HIGH input connector.

GUARD Connector

Isolated connector connected to a shield that encloses the analog circuitry of the instrument. If a GUARD test lead is not used, the GUARD connector is connected to the LOW connector by an internal switch in the connector assembly. If a GUARD test lead is used, it is normally connected to the LOW test lead at the point of measurement by the user. The GUARD is used to maximize common mode rejection.

15 Ground Binding Post

Chassis ground connector.

16 Release Latch

Pull to remove plug-in.

OPERATORS FAMILIARIZATION

The following discussion describes the use of the DM 5010 front panel controls and connectors under local operation.

Power On Self Test

Upon application of power, the DM 5010 performs a self-test routine. During the self test, all front panel LEDs illumi-

nated. After the self test, the instrument enters the Local State (LOCS) and assumes the power on default settings listed in Table 2-1.

**Table 2-1
POWER ON SETTINGS
(FRONT PANEL FUNCTIONS ONLY)**

| Front-Panel Control | Status |
|---------------------|-------------------------|
| DCV | on |
| OHMS | off |
| NULL | (off) Constant set to 0 |
| DIODE TEST | off |
| ACV | off |
| ACV+DCV | off |
| LOW FREQ RESPONSE | off |
| AUTO | on |
| STEP | off |
| RUN | on |
| TRIGGERED | off |
| FAST | off |
| AVERAGE | off |
| N | Constant set to 2 |
| <u>X-B</u> | |
| A | off |
| A | Constant set to 0 |
| B | Constant set to 1 |
| dBm | off |
| dBr | off |
| ref | Constant set to 1 |
| COMPARE | off |
| LIMITS | Constants set to 0, 0 |
| REAR INPUT | off |

If an internal error is detected during self test, the instrument continuously displays a three-digit error code in the display window and the ERROR indicator is lit. See Table 2-2. Refer an error code condition to qualified service personnel.

**Table 2-2
FRONT PANEL ERROR CODES**

| Displayed | Abnormal Event |
|-----------|--------------------------------|
| | Execution Errors: |
| 205 | Argument out of range. |
| 231 | Not in calibrate mode. |
| 232 | Beyond calibration capability. |
| | Internal Errors: |
| 303 | Math pack error. |
| 311 | Converter time-out. |
| 317 | Front panel time-out. |
| 318 | Bad calibration constant. |
| 340 | RAM error (high nibble). |
| 341 | RAM error (low nibble). |
| 351 | Calibration checksum error. |
| 372 | ROM placement error. C000 |
| 373 | ROM placement error. D000 |
| 374 | ROM placement error. E000 |
| 392 | ROM checksum error. C000 |
| 393 | ROM checksum error. D000 |
| 394 | ROM checksum error. E000 |
| 395 | ROM checksum error. F000 |

General Operating Information

Allow 30 minutes warmup time for operation to specified accuracy. Over-range for the OHMS and DIODE TEST functions causes the instrument to display OC; for the DCV, ACV, and ACV + DCV functions; over-range is indicated by a flashing display.



Observe the specified maximum input voltage ratings. Instrument damage may occur if the maximum input voltage ratings are exceeded.

For all measurement functions, range selection may be either auto-ranging (AUTO button pressed) or a fixed range may be selected using the STEP button. Refer to the range indication discussion under Display Window. DIODE TEST uses only the 2 V range.



With the instrument in the AUTO range mode, do not repeatedly switch the input voltage between a low value (<200 mV peak) and a higher value (>200 V peak). For repeated measurements alternating between voltage extremes, use the STEP range mode to select an appropriate higher range before increasing the input voltage. Failure to do so may temporarily cause inaccuracy in measurements made using the 200 mV range.

Input Connections

The HIGH, LOW, and GUARD connectors are used for front-panel measurements. The connector assembly contains an internal switch connected between the LOW and GUARD connectors. This switch is closed until a test lead probe is inserted into the GUARD connector; it remains open until the GUARD test lead probe is removed.

Figure 2-4 illustrates three examples of using the front-panel connectors to make measurements. Method A is the most commonly used. It is used when common mode voltage is not a consideration. In this example, only the HIGH and LOW connectors of the DM 5010 are used. Since a test lead probe is not inserted into the GUARD connector, the connector assembly internal switch is closed, shorting the LOW to the GUARD. This allows common mode current to flow through the LOW test lead and the power source ground, introducing some measurement error.

Method B provides the most accurate measurements when common mode voltages are a problem. The DM 5010 GUARD connector is connected to the source low terminal. Common mode current flows through the GUARD test lead and power source ground, not the measurement circuits.

In Method C, the DM 5010 GUARD connects to the source ground. Some measurement error may occur, since common mode current generated between the source low and power source ground flows in the measurement circuit.



To help eliminate shock hazard from voltages measured by the DM 5010:

- 1. Avoid all contact with the voltage source if the measured voltage exceeds 42.4 V peak.*
- 2. Disconnect test probes from the circuit-under-test before disconnecting probes from the DM 5010, or before removing the DM 5010 from the power module.*

Rear-Interface Measurements

If the REAR INPUT button is pressed (illuminated), signals applied to the rear interface pins 28B (Hi) and 28A (Lo) on the ADC board (A17) are measured. If the button is not illuminated, signals are measured via the front-panel input connectors.

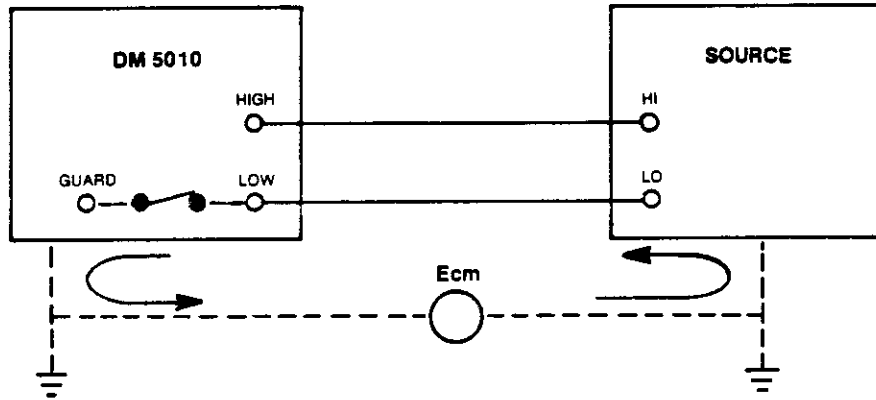

A. Guard connected (internally) to DM 5010 LOW terminal— E_{cm} error present.

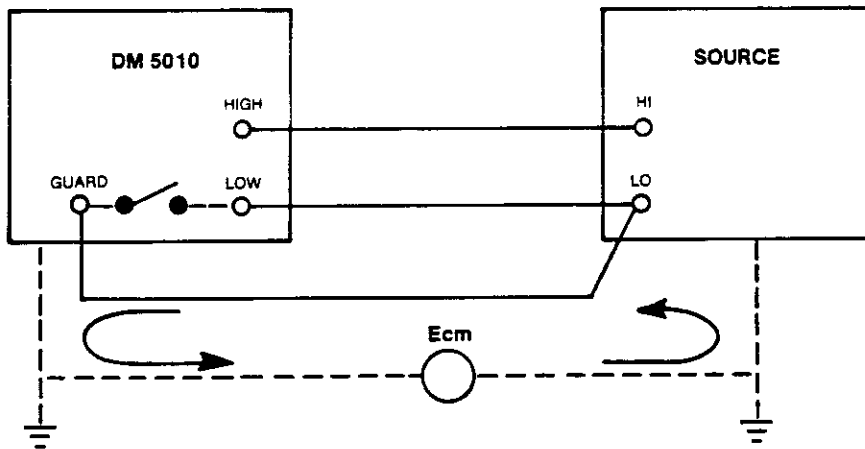

B. Guard connected to source Lo terminal—No E_{cm} error.

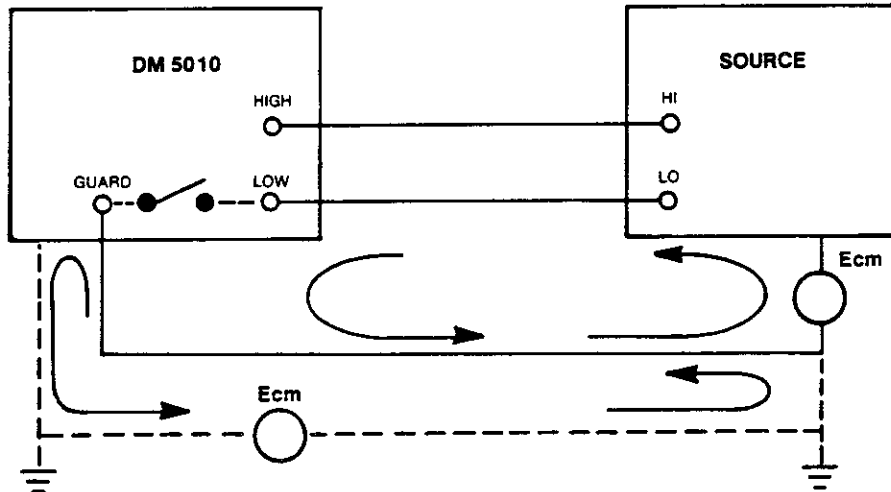

C. Guard connected to source chassis ground. Low E_{cm} error, assuming the common error source is mostly between grounds.

2994-04

Fig. 2-4. Examples of front panel input connection methods.

CAUTION

To avoid equipment damage, do not apply a voltage exceeding 42.4 V peak ac or 60 V dc between pins 28B (Hi) and 28A (Lo) of the rear-interface connector P1031 on the ADC board (A17).

CAUTION

Do not switch from front-panel to rear interface input while over 500 V peak is applied to the front panel input connectors. Instrument damage and erratic operation may result.

Dc Voltage Measurements

When the DCV button is pressed, the DM 5010 measures dc voltages using the following ranges: 200 mV, 2 V, 20 V, 200 V, and 1000 V. The readout displays a positive sign when the input to the HIGH connector is positive with respect to the LOW connector. Observe the maximum input voltage ratings.

Resistance Measurements

Pressing the OHMS button enables the DM 5010 to measure resistance using these ranges: 200 Ω, 2 kΩ, 20 kΩ, 200 kΩ, 2 MΩ, and 20 MΩ. Conventional current flow is from the HIGH connector to the LOW connector. Refer to Table 2-3 for the value of current and maximum voltages across the input connectors for full scale display readings (instrument not over-ranged). The maximum (open circuit) voltage available from the HIGH connector referenced to the LOW connector is less than 5 V.

**Table 2-3
SOURCE VOLTAGES
(OHMS FUNCTION)**

| Range | Typical Current (0 Ω to Full Scale) | V Max (Full Scale) |
|--------|--|-----------------------|
| 200 Ω | 1.02 mA to 1 mA | 0.2 V |
| 2 kΩ | 0.12 mA to 0.1 mA | |
| 20 kΩ | 9.2 μA to 10 μA | |
| 200 kΩ | 1.08 μA to 1 μA | |
| 2 MΩ | 0.12 μA to 0.1 μA | |
| 20 MΩ | 0.12 μA to 0.04 μA | 0.8 V |

Measuring Diodes

Pressing the DIODE TEST button causes the DM 5010 to generate a 1 mA dc current at the HIGH connector. The forward voltage drop of diode junctions is measured by connecting the diode anode to the HIGH connector and the

cathode to the LOW. Devices that can be checked are those having a voltage drop under 1.999 volts. These include most diodes and some LEDs.

To check the reverse voltage drop, reverse the diode connections to the instrument. The display window should display OC.

Ac Voltage Measurements

The DM 5010 provides two ac measurement functions. True rms ac voltages are measured and displayed using the ACV function. True rms ac voltages elevated to a dc level are measured and displayed using the ACV + DCV function. Ranges for both functions are 200 mV, 2 V, 20 V, 200 V, and 700 V. Voltages can be measured with a crest factor up to four at full scale. The crest factor is the ratio of the peak voltage to rms voltage. Observe the maximum input voltage ratings. The LOW FREQ RESPONSE function provides a stable display for low-frequency ac measurements. When activated, this function displays the average of four ac measurements.

Conversion Rates

The DM 5010 operates at either of two conversion rates. The FAST rate (CONVERSION RATE button illuminated) makes measurements at the maximum rate specified for the selected function. Measurements are displayed using 3 1/2 digits. With the button not illuminated, the instrument makes measurements at the normal rate specified for the selected function and uses a 4 1/2 digit display.

Triggering

The DM 5010 has two front-panel trigger modes, RUN and TRIGGERED. When the RUN button is pressed, conversions are free-running at the selected conversion rate. Pressing the TRIGGERED button causes the instrument to trigger one measurement each time the button is pressed.

In addition, conversions may be triggered via the rear interface connector, pin 16A and 16B (Lo) on the Isolation board (A15). Use of this feature requires installation of an internal jumper. Refer qualified service personnel to the Maintenance section of this manual for additional information. Installation of this jumper enables the EXTRIG trigger function in addition to the RUN and TRIGGERED functions. To use the EXTRIG trigger, activate the TRIGGER button to disable the instrument's free-running trigger. The EXTRIG requires a negative-going TTL compatible signal to initiate the internal trigger. To cause a single trigger, this line must be held low between 0.5 and 10 μsec. If held low for a longer time, the instrument triggers multiple measurements.

Calculations

Five front-panel buttons activate calculations on measurements made by the DM 5010. These calculations may be performed singly or in a sequence. A sequence of calculations may be activated (buttons pushed) in any order; however, the DM 5010 executes them in the following order: AVERAGE, X-B/A, dBm or dBr, COMPARE. The instrument performs all activated calculations on the measurement and then displays the result. If active, NULL and then LOW FREQ RESPONSE are executed before any of the calculations. Both of the calculations dBm and dBr cannot be performed in the same sequence. If both buttons are pressed in the same calculation sequence, only the last one pressed will be executed. One trigger begins execution of a single calculation or a calculation sequence. In the RUN trigger mode, an activated calculation or sequence repeats until turned off (calculation button(s) pressed again), or until the trigger mode or measurement function is changed. The display LEDs blank while calculations are being executed. The instrument displays OC to indicate a display overflow for calculation results.

Except for dBm, each calculation uses one or more constants. The numerical value stored in memory for each constant is set to a default value at instrument power up. This value may be changed to any value within the limits specified for each constant. Table 2-4 lists each calculation

and associated constant(s), constant default values, and the limits for each constant.

Changing Constant Values

There are two methods for changing constant values in the instrument memory.

1. Using the numeric keyboard:
 - a. Press selected constant button.
 - b. Press numeric keyboard buttons to display the new constant value (within the limits specified in Table 2-4).
 - c. Press ENTER.

2. Using a displayed measurement. (Changes a constant value to the value of the displayed measurement.) Make certain the displayed measurement meets the limits specified in Table 2-4 for the selected constant.
 - a. Press selected constant button.
 - b. Press ENTER.

**Table 2-4
CALCULATION AND CONSTANTS**

| Calculation | Constants | Default Value | Valid Constant Range |
|-----------------|------------|---------------|---------------------------------|
| AVERAGE | N | 2 | +1 to +19999 |
| $\frac{X-B}{A}$ | B (offset) | 0 | + or -, integer or decimal, |
| | A (scale) | 1 | + or -, integer or decimal, ≠ 0 |
| dBm | - | - | - |
| dBr | ref | 1 | + or -, integer or decimal, ≠ 0 |
| COMPARE | LIMITS (2) | 0 | |

After the ENTER button is pressed, the DM 5010 displays the stored constant value. The displayed value is the new one if the entered value was valid. The previously-stored value is displayed if the entered value was invalid. Each constant value remains stored until a new value is entered or until power is removed from the instrument.

Calculation Examples

The following examples are provided to suggest applications using the DM 5010 calculations.

Example 1: Using X-B/A to display the difference between the nominal and actual zener voltages.

Set the DM 5010 front-panel controls as follows:

| | |
|-------------------|----------|
| DCV | on |
| NULL | off |
| LOW FREQ RESPONSE | off |
| RANGE | AUTO |
| TRIGGER MODE | RUN |
| CONVERSION RATE | FAST off |
| CALCULATIONS | |
| X-B | |
| A | on |
| all others | off |
| REAR INPUT | off |

Set the constant A to 1.

Set the constant B to 15 (for a 15 V zener diode).

Connect the zener diode, resistor, and power supply to the DM 5010 input connectors as shown in Fig. 2-5. The value of the resistor and the power supply voltage set the zener current.

The displayed voltage initially is unstable until the current through the diode reaches its final value. When the display stabilizes, the displayed voltage is the difference between the nominal zener voltage (15 V) and the actual zener voltage for the zener diode being measured.

To read the voltage difference in percent deviation, change constant A to .15 where A=B (.01).

Example 2: Using dB_r to find the point where an audio amplifier is 3 dB down from mid-range.

Set the DM 5010 front-panel controls as follows:

| | |
|-------------------|----------|
| ACV | on |
| NULL | off |
| LOW FREQ RESPONSE | off |
| RANGE | AUTO |
| TRIGGER MODE | RUN |
| CONVERSION RATE | FAST off |
| CALCULATIONS | off |
| REAR INPUT | off |

Set constant ref to 1. Connect a sinewave generator, the audio amplifier, and the DM 5010 as shown in Fig. 2-6.

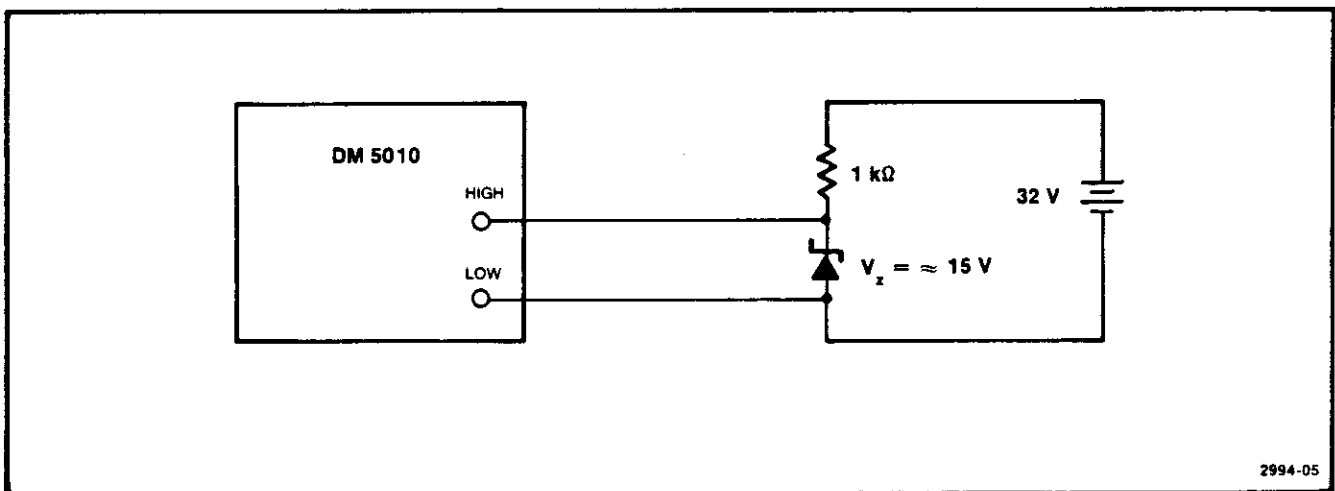

Fig. 2-5. Setup for calculation example 1.

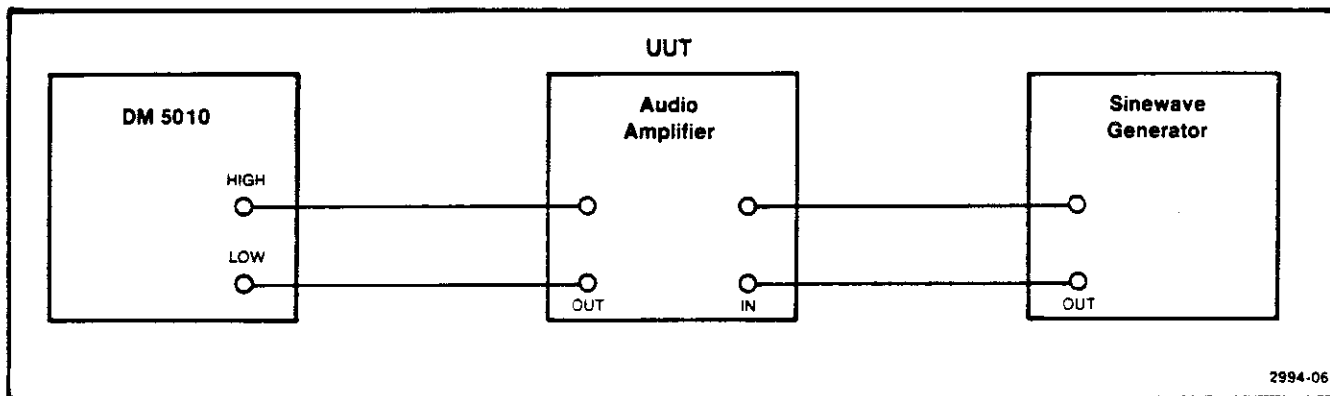

Fig. 2-6. Setup for calculation example 2.

Set the sinewave generator to mid-range (5 kHz in this example); adjust the sinewave generator amplitude for a 1 V reading on the DM 5010.

Press the DM 5010 dBr button. The display reads 0.0.

Reduce the sinewave generator frequency until the DM 5010 display reads -3.00. (Do not readjust amplitude.) The frequency of the generator is the lower -3 dB point of the audio amplifier.

Example 3: Using COMPARE to select resistors within 2% of the nominal value.

Set the DM 5010 front-panel controls as follows:

| | |
|-------------------|----------|
| OHMS | on |
| NULL | off |
| LOW FREQ RESPONSE | off |
| RANGE | AUTO |
| TRIGGER MODE | RUN |
| CONVERSION RATE | FAST off |
| CALCULATIONS | |
| COMPARE | on |
| all others | off |
| REAR INPUT | off |

To select 15 kΩ resistors within 2% of the nominal value, set one LIMITS constant to 15300. Set the other LIMITS constant to 14700. Connect the first resistor to the DM 5010 front-panel HIGH and LOW input connectors. The DM 5010 displays HI or LO if the resistor is above or below the 2% tolerance. PASS is displayed if the resistor is between or equal to the limits.

The COMPARE and X-B/A calculations may be combined in the above example. This combination eliminates figuring the highest and lowest in-tolerance values; only the nominal resistance value and the tolerance are used as constants.

Set constant B to 15000 (nominal resistance).

Set constant A to 150 where $A=B(.01)$. This converts the difference between nominal value and actual value to a per cent.

Set one LIMITS constant to 2 (for a 2% tolerance).

Set the other LIMITS constant to -2.

Press X-B/A.

The DM 5010 displays PASS, HI, or LO.

Repackaging Information

If this Tektronix instrument is to be shipped to a Tektronix Service Center for service or repair, attach a tag showing owner (with address) and the name of an individual at your firm that can be contacted. Include the complete instrument serial number and a description of the service required.

Save and re-use the package in which the instrument was shipped. If the original packaging is unfit for use or not available, repackage the instrument as follows:

Surround the instrument with polyethylene sheeting to protect the finish of the instrument. Obtain a carton of corrugated cardboard of the correct carton strength and having inside dimensions of no less than 6 inches more than the instrument dimensions. Cushion the instrument by tightly packing at least 3 inches of dunnage or

urethane foam between carton and instrument on all sides. Seal the carton with shipping tape or an industrial stapler.

The carton test strength for this instrument is 200 pounds per square inch.

PROGRAMMING

Introduction

This section of the manual provides information for programming the TEKTRONIX DM 5010 Programmable Digital Multimeter via the IEEE-488 digital interface. The IEEE-488 interface function subsets for the DM 5010 are listed in Section 1. In this manual, the IEEE-488 digital interface is called the General Purpose Interface Bus (GPIB). The following information assumes the reader is knowledgeable in GPIB communication and has some exposure to programming controllers. Message protocol over the GPIB is specified and described in the IEEE Standard 488-1978, *Standard Digital Interface for Programmable Instrumentation*¹. TM 5000 instruments are designed to communicate with any GPIB-compatible controller that sends and receives ASCII messages (commands) over the GPIB. These commands program the instrument or request information from the instrument.

Commands for TM 5000 programmable instruments are designed for compatibility among instrument types. The same command is used in different instruments to control similar functions. In addition, commands are specified in mnemonics related to the functions they implement. For example, the command INIT initializes instrument settings to their power-up states. For further ease of programming, command mnemonics are similar to front-panel control names.

Instrument commands are presented in three formats:

- A front panel illustration—showing command relationships to front panel operation. See Fig. 3-1.
- Functional Command List—a list divided into functional groups with brief descriptions.
- Detailed Command List—an alphabetical listing of commands with complete descriptions.

¹Published by the Institute of Electrical and Electronics Engineers, Inc., 345 East 47th Street, New York, N.Y., 10017.

TM 5000 programmable instruments connect to the GPIB through a TM 5000 power module. Refer to the Operating Instructions section of this manual for information on installing the instrument in the power module. Also review this section for instrument caution and warning statements and to become familiar with front-panel and internally selectable instrument functions.

The GPIB primary address for this instrument may be internally changed by qualified service personnel. The DM 5010 is shipped with the address set to decimal 16. The message terminator may also be internally selected by qualified service personnel. Message terminators are discussed in Messages and Communication Protocol (in this section). TM 5000 instruments are shipped with this terminator set to EOI ONLY. Refer qualified service personnel to the Maintenance section of this manual for locations and setting information. Pressing the INST ID button causes the instrument to display its selected GPIB primary address; the far right decimal point lights if the selected message terminator is LF/EOI. The minus sign lights if the Talk Only mode is enabled.

Talk Only Mode

The Talk Only mode enables the DM 5010 to send data under local control over the GPIB to a listener. To initiate this mode, an internal switch is set to the Talk Only position. Refer qualified service personnel to the Maintenance section of this manual for switch setting information.

With the Talk Only mode enabled, the DM 5010 begins sending measurement data when the front panel INST ID button is pressed; it stops sending data when the front panel CLEAR button is pressed. If the instrument is sending a reading when CLEAR is pressed, it completes sending that reading. The ADDRESSED light remains on until transmission of the last reading is complete.

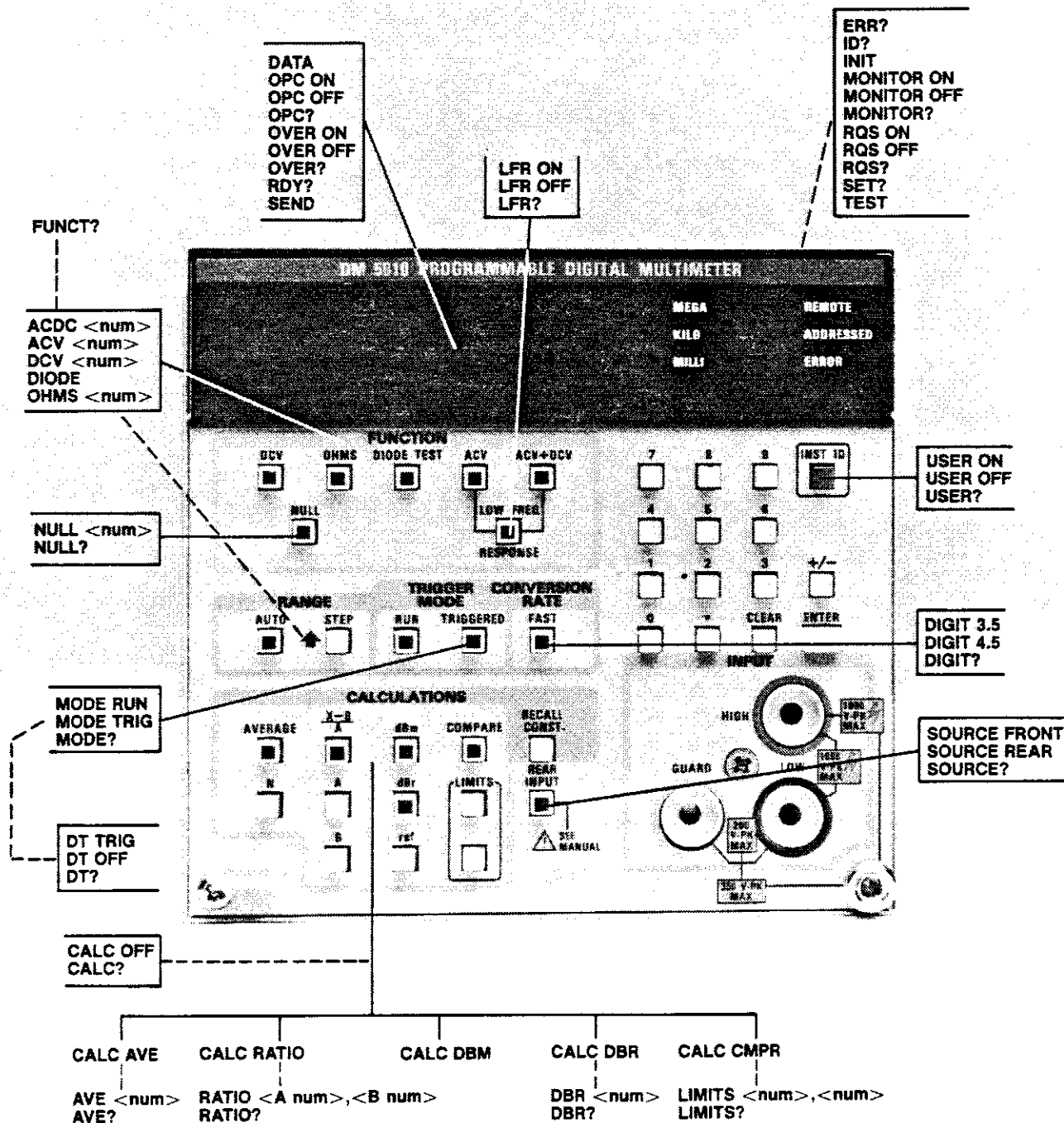

Fig. 3-1. Instrument commands and relationship to front panel controls.

COMMANDS

The instrument is controlled by the front panel or via commands received from the controller. These commands are of three types:

Setting commands—control instrument settings.

Query-output commands—ask for data.

Operational commands—cause a particular action.

CAUTION

Using fewer characters than the abbreviated header or argument should be done with caution since erroneous results or damage could result if this data is sent to the wrong instrument.

The instrument responds to and executes all commands when in the remote state. When in the local state, *setting* and *operational commands* generate errors since instrument functions are under front panel control; only *query-output commands* are executed.

Each command begins with a header—a word that describes the function implemented. Many commands require an argument following the header—a word or number that specifies the desired state for the function.

CAUTION

With the instrument in the AUTO range mode, do not repeatedly switch the input voltage between a low value (<200 mV peak) and a higher value (>200 V peak). For repeated measurements alternating between these voltage extremes, use the STEP range mode to select an appropriate higher range before increasing the input voltage. Failure to do so may temporarily cause inaccuracy in measurements made using the 200 mV range.

FUNCTIONAL COMMAND LIST

INSTRUMENT COMMANDS

Function Commands

ACDC <num>—Sets the ACV+DCV function and range.

ACV <num>—Sets the ACV function and range.

DCV <num>—Sets the DCV function and range.

DIODE—Sets the DIODE TEST function.

FUNCT?—Returns present function and range.

LFR ON—Enables the LOW FREQ RESPONSE function.

LFR OFF—Disables the LOW FREQ RESPONSE function.

LFR?—Returns LFR ON or LFR OFF.

NULL <num>—Enables the NULL function and offset value.

NULL?—Returns NULL offset value.

OHMS <num>—Sets the OHMS function and range.

Trigger Mode Commands

MODE RUN—Enables the RUN trigger mode.

MODE TRIG—Enables the TRIGGERED trigger mode.

MODE?—Returns MODE RUN or MODE TRIG.

RDY?—Returns RDY 1 if a measurement is ready; RDY 0 if one is in progress or waiting for trigger.

DIGIT 3.5—Enables FAST conversion rate.

DIGIT 4.5—Enables normal conversion rate.

DIGIT?—Returns DIGIT 3.5 or DIGIT 4.5.

Calculation Commands

AVE <num>—Sets the value of constant N.

AVE?—Returns value of constant N.

CALC AVE—Enables the AVERAGE calculation.

CALC CMPR—Enables the COMPARE calculation.

CALC DBM—Enables the dBm calculation.

CALC DBR—Enables the dB_r calculation

CALC RATIO—Enables X-B/A calculation.
CALC OFF—Disables all calculations.
CALC?—Returns CALC OFF or the enabled calculation(s).
DBR <num>—Sets the value of the ref constant.
DBR?—Returns value of ref constant.
LIMITS <num>,<num>—Sets values of LIMITS constants.
LIMITS?—Returns values of LIMITS constants.
MONITOR ON—Enables SRQ when measurement exceeds LIMITS constants.
MONITOR OFF—Disables SRQ when measurement exceeds LIMITS constants.
MONITOR?—Returns MONITOR ON or MONITOR OFF.
RATIO <num>,<num>—Sets values of A and B constants.
RATIO?—Returns values of A and B constants.

INPUT/OUTPUT COMMANDS

DATA—Outputs data saved by MONITOR SRQ.
SEND—Outputs data in Output Buffer; triggers, if necessary.
SOURCE REAR—Selects rear interface connector input.
SOURCE FRONT—Selects front panel connector input.
SOURCE?—Returns SOURCE FRONT or SOURCE REAR.

SYSTEM COMMANDS

DT TRIG—Enables device trigger function. Instrument triggers after <GET> interface message.
DT OFF—Disables device trigger function.
DT?—Returns DT TRIG or DT OFF.
ERR?—Returns error code.
ID?—Returns instrument identification and firmware version.
INIT—Initializes instrument settings.
SET?—Returns instrument settings.
TEST—Returns 0 for correct calibration checksum; 351 for incorrect.

STATUS COMMANDS

OPC ON—Enables operation complete SRQ.
OPC OFF—Disables operation complete SRQ.
OPC?—Returns OPC ON or OPC OFF.
OVER ON—Enables overrange SRQ.
OVER OFF—Disables overrange SRQ.
OVER?—Returns OVER ON or OVER OFF.
RQS ON—Enables generation of SRQ's.
RQS OFF—Disables generation of SRQ's.
RQS?—Returns RQS ON or RQS OFF.
USER ON—Enables SRQ when ID button is pushed.
USER OFF—Disables SRQ when ID button is pushed.
USER?—Returns USER ON or USER OFF.

DETAILED COMMAND LIST

ACDC (AC with DC Voltage Function)

Type:

Setting

Setting syntax:

ACDC <number>
 ACD <number>
 ACDC

Examples:

ACDC 2
 ACDC .9
 ACD -200
 ACD
 ACD 0

Range Selected:

2 V
 2 V
 700 V, auto-range
 700 V, auto-range
 700 V, auto-range

Discussion:

The header selects the ACD+DCV function; the argument selects a fixed range or auto-range. The format for numeric arguments is described under Number Format later in this section of the manual. The argument can be any value ≤ 700 ; however, the instrument rounds the argument up to the next full scale range. For instance, for an argument of .9, the instrument selects the 2 V range.

If the argument is omitted or its value is 0 or less, the instrument auto-ranges beginning at the highest range.

If the argument is above the highest range, the instrument generates a command error (and asserts SRQ if RQS is on).

Ranges:

200 mV
 2 V
 20 V
 200 V
 700 V

ACV (AC Voltage Function)

Type:

Setting

Setting syntax:

ACV <number>
 ACV

Examples:

ACV 18
 ACV 2
 ACV -200
 ACV

Range Selected:

20 V
 2 V
 700 V, auto-range
 700 V, auto-range

Discussion:

The header selects the ACV function; the argument selects a fixed range or auto-range. The format for numeric arguments is described under Number Format later in this section of the manual. The argument can be any value; however, the instrument rounds the argument up to the first full scale range. For instance, an argument of 18 selects the 20 V range.

If the argument is omitted or its value is 0 or less, the instrument auto-ranges beginning at the highest range.

If the argument is above the highest range, the instrument generates a command error (and asserts SRQ if RQS is on).

Ranges:

200 mV
 2 V
 20 V
 200 V
 700 V

AVE (Average)

Type:

Setting or query

Setting syntax:

AVE <number>
AVG <number>

Examples:

AVE 6
AVE 2
AVG 10

Query syntax:

AVE?
AVG?

Query response:

AVE <number>;

Discussion:

This command specifies the number of conversions used in the AVERAGE calculation. (It corresponds to setting the value for the front panel button constant N.) See CALC AVE. The argument may be any number from 1 to 19999. The instrument truncates the argument to integers.

CALC (Calculation Operation)

Type:

Setting or query

Setting syntax:

CALC <argument>
 CALC <argument>,. . . .,<argument>

Arguments:

AVE or AVG
 CMPR or COMP
 DBM
 DBR
 RATIO
 OFF

Examples:

CALC OFF
 CALC AVE
 CALC AVE, DBM
 CALC RATIO, AVE, DBR

Query syntax:

CALC?

Query response:

CALC OFF; or list of enabled calculation(s).

Discussion:

When the instrument receives a CALC command, it turns off all calculations except those listed after the CALC header. If the result of a calculation exceeds the capabilities of the math pack ($\pm 3.4028E+38$), the instrument generates a math pack error (303).

- CALC AVE or CALC AVG enables the AVERAGE calculation. The instrument calculates the average of a

series of measurements. The number of measurements in the series is set by the AVE <number> command.

One trigger generates enough readings for an average result. If over-range occurs for a measurement in a sequence, the AVE calculation is aborted.

If LFR is also enabled, the number of measurements set by the AVE <number> command is multiplied by 4.

- CALC CMPR or CALC COMP enables the COMPARE calculation. The instrument compares the input to the values set by the LIMITS command. Refer to the text on the following commands, which output comparison results:

SEND—returns 1., 2., or 3. for LO, PASS, or Hi; returns +1E+99; or -1E+99; for over-range.

DATA—returns out-of-limits measurement value.

- CALC DBM enables the dBm calculation and disables the dBr calculation. The instrument calculates the power ratio of the input voltage, referenced to 1 mW dissipated in 600 Ω (.7746 V).

$$\text{dBm} = 20 \log_{10} \left| \frac{X}{\sqrt{.6}} \right|$$

- CALC DBR enables the dBr calculation and disables the dBm calculation. The DM 5010 computes the logarithmic ratio of the input to the value set by the DBR <number> command.

$$\text{dBr} = 20 \log_{10} \left| \frac{X}{\text{ref}} \right|$$

- CALC RATIO enables the X-B/A calculation, where X is the measurement, B is an offset value, and A is the scale factor. The values of A and B are set by the RATIO command.
- CALC OFF disables all calculations.

DATA

Type:

Output

Syntax:

DATA

Response:

DATA <number>;
or
DATA ±1.E+99; (for over-range)

Discussion:

This command returns one of the responses listed below. It does not trigger a conversion nor wait to return a new reading as the SEND command does.

1. After power on, returns 0 until a reading is available.

2. If a MONITOR SRQ has occurred, DATA returns the measurement causing the SRQ.

3. If neither of the above conditions is true, DATA returns the most recent reading. DATA returns the same reading until the next conversion is triggered and a new reading is available.

DATA may return more digits of resolution for a reading than is displayed on the front panel or returned by the SEND command.

DBR

Type:

Setting or query

Setting syntax:

DBR <number>

Examples:

DBR 1
DBR .707
DBR 2E-3

Query Syntax:

DBR?

Query Response:

DBR <number>;

Discussion:

This command argument sets the value of the constant used by the CALC DBR command. It corresponds to setting the constant value for the front panel button constant ref. The argument can be any number except 0.

DCV (DC Voltage Function)**Type:**

Setting

Setting syntax:DCV <number>
DCV**Examples:**

| | Range selected: |
|------------|------------------------|
| DCV 1.5 | 2 V |
| DCV | 1000 mV, auto-range |
| DCV -1.E+3 | 1000 V, auto-range |

Discussion:

The header selects the DCV function; the argument selects a fixed voltage range. The format for numeric arguments is described under Number Format later in this section of the manual. The argument can be any value; however, the instrument rounds the argument up to the first full scale range. For instance, for an argument of 1.5, the instrument selects the 2 V range.

If the argument is omitted or its value is 0 or less, the instrument auto-ranges beginning at the highest range.

If the argument is above the highest range, the instrument generates a command error (and asserts SRQ if RQS is on).

Ranges:

200 mV
2 V
20 V
200 V
1000 V

DIGIT (Digital Resolution)**Type:**

Setting or query

Setting syntax:DIGIT 3.5
DIGIT 4.5
DIG 3.5
DIG 4.5**Query syntax:**DIGIT?
DIG?**Query response:**DIGIT 3.5;
DIGIT 4.5;**Discussion:**

This command selects the conversion rate. The argument 3.5 sets the FAST conversion rate (3.5 digit resolution). A reading takes approximately 35 ms in the voltage functions and approximately 130 ms in the OHMS function.

The argument 4.5 sets the normal conversion rate (4.5 digit resolution). A reading takes approximately 310 ms in the voltage functions; 620 ms in the OHMS function.

DIODE (Diode Test Function)

Type:

Setting

Setting syntax:

DIODE
DIO

Discussion:

This command selects the DIODE TEST function. An argument is not accepted.

DT (Device Trigger)

Type:

Setting or query

Setting syntax:

DT TRIG
DT OFF

Query syntax:

DT?

Query response:

DT TRIG;
DT OFF;

Discussion:

This command enables or disables the device trigger function. If Device Trigger is enabled, the <GET> IEEE 488 interface message causes the instrument to trigger a reading.

If <GET> is received while the message processor is busy or when DT is OFF, the instrument generates an error, which indicates the <GET> message was ignored.

ERR? (Error)**Type:**

Query

Query syntax:

ERR?

Query response:ERR_{sp sp} <number>**Examples:**ERR_{sp sp} 401; (power on)**Discussion:**

The ERROR query is used to obtain information about the status of the instrument.

The ERROR query returns a code indicating the event causing SRQ to be asserted. See Status and Error Reporting for more information.

FUNCT? (Function)**Type:**

Query

Query syntax:FUNCT?
FUNC?**Query response example:**DCV 2.;
ACV 20.;
DIODE;
ACDC 200.;
OHMS -2.E+6;**Discussion:**

This command returns the measurement function in use. The argument specifies the range currently in use. A negative argument is returned if the instrument is in autorange.

ID?

Type:

Query

Query syntax:

ID?

Query response:

ID TEK/DM5010,V79.1 Fxx;

Discussion:

The ID? query returns the above response.

TEK/DM5010 — Identifies the instrument manufacturer and type.

V79.1 — Identifies the version of Tektronix Codes and Format Standard to which the instrument conforms.

Fxx — Identifies the firmware version of the instrument.

INIT

Type:

Operational

Syntax:

INIT

Discussion:

This command resets instrument functions to their power-on settings. Table 3-3 lists the power-on settings.

LFR (Low Frequency Response)**Type:**

Setting or query

Setting syntax:LFR ON
LFR OFF**Query syntax:**

LFR?

Query response:LFR ON;
LFR OFF;**Discussion:**

This command enables or disables the LOW FREQ RESPONSE function (used with ACV and ACV+DCV functions). When enabled, the instrument computes the average of four measurements.

If CALC AVE is also enabled, the number of measurements set by the AVE <num> command is multiplied by 4.

LIMITS**Type:**

Setting or query

Setting syntax:LIMITS <number>, <number>
LIM <number>, <number>**Examples:**LIMITS 3.2, -2
LIMITS -1, -6.5
LIM 6, 1**Query syntax:**LIMITS?
LIM?**Query response:**

LIMITS <number>, <number>;

Discussion:

The arguments for this command set the value of the limits used by the COMPARE calculation and the MONITOR SRQ. The first argument sets the value of the limit, which corresponds to the upper front panel LIMITS button; the second argument sets the constant value, which corresponds to the lower LIMITS button.

MODE

Type:

Setting or query

Setting syntax:

MODE RUN
MODE TRIG
MOD RUN
MOD TRIG

Query syntax:

MODE?
MOD?

Query response:

MODE RUN;
MODE TRIG;

Discussion:

This command selects the Trigger Mode. The RUN argument sets the RUN (free-run) Trigger Mode.

The TRIG argument sets the TRIGGERED mode. In this mode, a trigger occurs upon receipt of one of the following:

- A "SEND" command
- A Group Execute Trigger <GET> interface message (only if DT, Device Trigger, is enabled).
- My Talk Address (MTA) with the output unspecified (no query command).
- EXTRIG rear interface trigger (requires internal jumper installation—see Maintenance section). To cause a single trigger, this line must be held low between 0.5 and 10 μ sec. If held low for a longer time, the instrument triggers multiple measurements.

If over-range or under-range occurs while MODE TRIG is enabled and the instrument is in auto-range, it will change range and take another reading.

MONITOR

Type:

Setting or query

Setting syntax:

MONITOR ON
MONITOR OFF
MON ON
MON OFF

Query syntax:

MONITOR?
MON?

Query response:

MONITOR ON;
MONITOR OFF;

Discussion:

This command enables or disables the MONITOR SRQ. With the MONITOR SRQ enabled, the instrument saves the first measurement outside the limits (set by LIMITS command) and generates an SRQ. SRQ's are not generated for subsequent measurements (outside the limits) until the SRQ is serviced and the measurement is reported to the controller in response to the DATA command.

If the instrument over-ranges with MON ON, it reports an over-range error even though OVER is OFF.

NULL**Type:**

Setting or query

Setting syntax:

NULL <number>

Examples:NULL .2
NULL 0**Query syntax:**

NULL?

Query response:

NULL <number>;

Discussion:

This command enables the NULL function; the argument (in volts or ohms) specifies the value of the offset. This value can be any number up to 100% of the range.

The NULL function is disabled when the measurement function is changed or when the argument is 0. (Changing the measurement function also sets the argument to 0.)

WARNING

Use caution when the NULL function is enabled, since the measurement may not indicate the value of the voltage applied to the input connectors.

OHMS (Ohms Function)**Type:**

Setting

Setting syntax:OHMS <number>
OHMS**Examples:****Range selected:**

| | |
|------------|----------------------------|
| OHMS | 20 M Ω , auto-range |
| OHMS 100 | 200 Ω |
| OHMS -2E+7 | 20 M Ω , auto-range |
| OHMS 1E+4 | 20 k Ω |

Discussion:

The header selects the OHMS function; the argument selects the range. The format for numeric arguments is described under Number Format later in this section of the manual. The argument can be any value; however, the instrument rounds the argument up to the first full scale range. For instance, for an argument of 100, the instrument selects the 200 Ω range.

If the argument is omitted or its value is 0 or less, the instrument auto-ranges beginning at the highest range.

If the argument is above the highest range, the instrument generates a command error (and asserts SRQ if RQS is on).

Ranges:

200 Ω
2 k Ω
20 k Ω
200 k Ω
2 M Ω
20 M Ω

OPC (Operation Complete)

Type:

Setting or query

Setting syntax:

OPC ON
OPC OFF

Query syntax:

OPC?

Query response:

OPC ON;
OPC OFF;

Discussion:

This command enables or disables the operation complete service request. If enabled and RQS is ON, the instrument asserts SRQ when a new measurement is available.

OVER (Over-range)

Type:

Setting or query

Setting syntax:

OVER ON
OVER OFF

Query syntax:

OVER?

Query response:

OVER ON;
OVER OFF;

Discussion:

This command enables or disables the over-range service request. If enabled and RQS is ON, the instrument asserts SRQ when it takes an over-range measurement.

When OVER is OFF, the instrument returns $\pm 1.E+99$ when talked, to indicate over-range (does not assert SRQ).

RATIO**Type:**

Setting or query

Setting syntax:

RATIO <number>,<number>

Examples:

RATIO 100, 15

RATIO 10, 2

Query syntax:

RATIO?

Query response:

RATIO <number>,<number>;

Discussion:

The arguments for this command set the value of the offset and scale factor used in the X-B/A calculation. See CALC RATIO. The first argument sets the value of the scale factor (button A on the front panel); the second sets the offset value (button B on the front panel). The arguments can be any number except that scale factor cannot be 0.

RDY?**Type:**

Query

Query syntax:

RDY?

Query response:RDY_{sp sp} 0;RDY_{sp sp} 1;**Discussion:**

This command returns RDY 0 if a measurement is in progress or if the instrument is waiting for a trigger. RDY 1 indicates data is available.

RQS (Request Service)

Type:

Setting or query

Setting syntax:

RQS ON
RQS OFF

Query syntax:

RQS?

Query response:

RQS ON;
RQS OFF;

Discussion:

This command enables the instrument to generate any service requests. The OFF argument disables all service requests. See Status and Error Reporting for more information.

SEND

Type:

Output

Syntax:

SEND
SEN

Response:

<number>; (no header)

Example:

$\pm 1.E+99$; (over-range)
 $+3.2E+3$;

Discussion:

This command causes the instrument to output the latest measurement. If no measurement is available, the instrument triggers a measurement and then outputs it.

If the COMPARE calculation is enabled (CALC CMPR) the instrument outputs one of the following numbers which indicate the relationship between the input and the limits set by the LIMITS command:

- 3.; if the input is above both limits
 - 2.; if the input is between limits or equal to one of the limits
 - 1.; if the input is below both limits
- $+1.E+99$; or $-1.E+99$; if over-ranged.

SET?**Type:**

Query

Query syntax:

SET?

Query response example (power up settings):

DCV -1.E+3; AVE 2; RATIO 1. 0.; DBR 1.; LIMITS 0.,
 0.; CALC OFF; NULL 0.; DIGIT 4.5; LFR OFF; MODE
 RUN; SOURCE FRONT; DT OFF; MONITOR OFF; OPC
 OFF; OVER OFF; USER OFF; RQS ON;

Discussion:

This command returns the present settings of all instrument functions. The longest response is 225 characters.

SOURCE**Type:**

Setting or query

Setting syntax:

SOURCE FRONT
 SOURCE REAR
 SOUR FRONT
 SOUR REAR

Query syntax:

SOURCE?
 SOUR?

Query response:

SOURCE FRONT;
 SOURCE REAR;

Discussion:

SOURCE FRONT selects the front panel input for measurement; SOURCE REAR selects the rear interface input connectors for measurement.

CAUTION

Do not switch from front panel to rear interface input while over 500 V peak is applied to the front panel input connectors. Instrument damage and erratic operation may result.

TEST

Type:

Output

Syntax:

TEST

Response:

TEST 0;
TEST 351;

Discussion:

Returns a number that indicates the status of the calibration checksum. Returns 0 if the checksum is correct; 351 if erroneous.

USER

Type:

Setting or query

Setting syntax:

USER ON
USER OFF

Query syntax:

USER?

Query response:

USER ON;
USER OFF;

Discussion:

This command enables or disables the INST ID button service request. If enabled, the instrument asserts SRQ when the front panel INST ID button is pressed.

MESSAGES AND COMMUNICATION PROTOCOL

Command Separator

A message consists of one command or a series of commands, followed by a message terminator. Messages consisting of multiple commands must have the commands separated by semicolons. A semicolon at the end of a message is optional. For example, each line below is a message.

```
INIT
TEST;INIT;RQS ON;USER OFF;ID?;SET?
TEST;
```

Message Terminator

Messages may be terminated with EOI or the ASCII line feed (LF) character. Some controllers assert EOI concurrently with the last data byte; others use only the LF character as a terminator. The instrument can be internally set to accept either terminator. With EOI ONLY selected as the terminator, the instrument interprets a data byte received with EOI asserted as the end of the input message; it also asserts EOI concurrently with the last byte of the output message. With the LF/EOI setting, the instrument interprets the LF character without EOI asserted (or any data byte received with EOI asserted) as the end of an input message; it transmits carriage return (CR) followed by line feed (the LF with EOI asserted) to terminate output messages. Refer service personnel to the Maintenance section of the manual for information on setting the message terminator. TM 5000 instruments are shipped with EOI ONLY selected.

Formatting A Message

Commands sent to TM 5000 instruments must have the proper format (syntax) to be understood; however, this format is flexible in that many variations are acceptable. The following describes this format and the acceptable variations.

The instruments expect all commands to be encoded in ASCII; however, they accept both upper and lower case ASCII characters. All data output is in upper case.

As previously discussed, a command consists of a header followed, if necessary, by arguments. A command with arguments must have a header delimiter that is the space character (SP) between the header and the argument. The space character (SP), carriage return (CR), and line feed (LF) are shown as subscript in the following examples.

```
RQSSPON
```

If extra formatting characters SP, CR, and LF (the LF cannot be used for format in the LF/EOI terminator mode) are

added between the header delimiter and the argument, they are ignored by the instrument.

```
Example 1: RQSSPON;
```

```
Example 2: RQSSP SPON;
```

```
Example 3: RQSSP CRLF
           SP SPON
```

In general, these formatting characters are ignored after any delimiter and at the beginning and end of a message.

```
SPRQSSPON;CR LF
SPUSERSPOFF
```

In the command list, some headers and arguments are listed in two forms, a full-length version and an abbreviated version. The instrument accepts any header or argument containing at least the characters listed in the short form; any characters added to the abbreviated version must be those given in the full-length version. For documentation of programs, the user may add alpha characters to the full-length version. Alpha characters may also be added to a query header, provided the question mark is at the end.

```
USER?
USERE?
USEREQ?
USEREQUEST?
```

Multiple arguments are separated by commas; however, the instrument will also accept a space or spaces as a delimiter.

```
2,3
2SP3
2,SP3
```

NOTE

In the last example, the space is treated as a format character because it follows the comma (the argument delimiter).

Number Formats

The instrument accepts the following kinds of numbers for any of the numeric arguments.

- Signed or unsigned integers (including +0 and -0). Unsigned integers are interpreted as positive. Examples: +1, 2, -1, -10
- Signed or unsigned decimal numbers. Unsigned decimal numbers are interpreted to be positive. Examples: -3.2, +5.0, 1.2

- Floating point numbers expressed in scientific notation. Examples: $+1.0E-2$, $1.0E-2$, $1.E-2$, $0.01E+0$

The largest acceptable number for an argument is $\pm 3.4028E+38$.

Message Protocol

As the instrument receives a message it is stored in the Input Buffer, processed, and executed. Processing a message consists of decoding commands, detecting delimiters, and checking syntax. For *setting commands*, the instrument then stores the indicated changes in the Pending Settings Buffer. If an error is detected during processing, the instrument asserts SRQ, ignores the remainder of the message, and resets the Pending Settings Buffer. Resetting the Pending Settings Buffer avoids undesirable states that could occur if some *setting commands* are executed while others in the same message are not.

Executing a message consists of performing the actions specified by its command(s). For *setting commands*, this involves updating the instrument settings and recording these updates in the Current Settings Buffer. The *setting commands* are executed in groups—that is, a series of *setting commands* is processed and recorded in the Pending Settings Buffer before execution takes place. This allows the user to specify a new instrument state without having to consider whether a particular sequence would be valid. Execution of the settings occurs when the instrument processes the message terminator, a *query-output command*, or an *operational command* in a message.

When the instrument processes a *query-output command* in a message, it executes any preceding *setting commands* to update the state of the instrument. It then executes the *query-output command* by retrieving the appropriate data and putting it in the Output Buffer. Then, processing and execution continue for the remainder of the message. The data are sent to the controller when the instrument is made a talker.

When the instrument processes an *operational command* in a message, it executes any preceding *setting commands* before executing the *operational command*.

Multiple Messages

The Input Buffer has finite capacity and a single message may be long enough to fill it. In this case, a portion of the message is processed before the instrument accepts additional input. During command processing the instrument holds off additional data (by asserting NRFD) until space is available in the buffer.

When space is available, the instrument can accept a second message before the first has been processed. However, it holds off additional messages with NRFD until it completes processing the first.

After the instrument executes a *query-output command* in a message, it holds the response in its Output Buffer until the controller makes the instrument a talker. If the instrument receives a new message before all of the output from the previous message is read, it clears the Output Buffer before executing the new message. This prevents the controller from getting unwanted data from old messages.

One other situation may cause the instrument to delete output. The execution of a long message might cause both the Input and Output buffers to become full. When this occurs, the instrument cannot finish executing the message because it is waiting for the controller to read the data it has generated; but the controller cannot read the data because it is waiting to finish sending its message. Because the instrument's Input buffer is full and it is holding off the rest of the controller's message with NRFD, the system is hung up with the controller and instrument waiting for each other. When the instrument detects this condition, it generates an error, asserts SRQ, and deletes the data in the Output buffer. This action allows the controller to transmit the rest of the message and informs the controller that the message was executed and that the output was deleted.

A TM 5000 instrument can be made a talker without having received a message that specifies what it should output. In this case, acquisition instruments (counters and multimeters) return a measurement if one is ready. If no measurement is ready, they return a single byte message with all bits equal to 1 (with message terminator); other TM 5000 instruments will return only this message.

Instrument Response to IEEE-488 Interface Messages

Interface messages and their effects on the instrument's interface functions are defined in IEEE Standard 488-1978. Abbreviations from the standard are used in this discussion, which describes the effects of interface messages on instrument operation.

UNL—Unlisten (63 with ATN)

UNT—Untalk (95 with ATN)

When the UNL command is received, the instrument's listener function goes to its idle state (unaddressed). In the idle state, the instrument will not accept instrument commands from the GPIB.

The talker function goes to its idle state when the instrument receives the UNT command. In this state, the instrument cannot output data via the GPIB.

The ADDRESSED light is off when both the talker and listener functions are idle. If the instrument is either talk addressed or listen addressed, the light is on.

IFC—Interface Clear (GPIB pin 9)

This uniline message has the same effect as both the UNT and UNL messages. The front panel ADDRESSED light is off.

DCL—Device Clear (20 with ATN)

The Device Clear message reinitializes communication between the instrument and controller. In response to DCL, the instrument clears any input and output messages and any unexecuted settings in the Pending Settings Buffer. Also cleared are any errors or events waiting to be reported, except the power-on event. If the SRQ line is asserted for any reason other than power-on when DCL is received, the SRQ is unasserted.

SDC—Selected Device Clear (4 with ATN)

This message performs the same function as DCL; however, only instruments that are listen addressed respond to SDC.

GET—Group Execute Trigger (8 with ATN)

The instrument responds to <GET> only if it is listen addressed and the instrument device trigger function has been enabled by the Device Trigger command (DT). The <GET> message is ignored and an SRQ generated if the DT function is disabled (DT OFF), the instrument is in the local state, or if a message is being processed when <GET> is received.

SPE—Serial Poll Enable (24 with ATN)

SPD—Serial Poll Disable (25 with ATN)

The SPE message enables the instrument to output serial poll status bytes when it is talk addressed. The SPD message switches the instrument back to its normal operation of sending the data from the Output Buffer.

MLA—My Listen Address

MTA—My Talk Address

The primary listen and talk addresses are established by the instrument's GPIB address (internally set). The current setting of the GPIB address is displayed on the front panel

when the ID button is pressed. When the instrument is addressed to talk or listen, the front panel ADDRESSED indicator is illuminated.

LLO—Local Lockout (17 with ATN)

In response to LLO, the instrument goes to a lockout state—from LOCS to LWLS or from REMS to RWLS.

REN—Remote Enable

If REN is true, the instrument goes to a remote state (from LOCS to REMS or from LWLS to RWLS) when its listen address is received. REN false causes a transition from any state to LOCS; the instrument stays in LOCS as long as REN is false.

A REN transition may occur after message processing has begun. In this case, execution of the message being processed is not affected by a transition.

GTL—Go To Local (1 with ATN)

Only instruments that are listen addressed respond to GTL by going to a local state. Remote-to-local transitions caused by GTL do not affect the execution of the message being processed when GTL was received.

Remote-Local Operation

The preceding discussion of interface messages describes the state transitions caused by GTL and REN. Most front panel controls cause a transition from REMS to LOCS by asserting a message called return-to-local (*rtl*). This transition may occur during message execution; but in contrast to GTL and REN transitions, a transition initiated by *rtl* does affect message execution. In this case, the instrument generates an error if there are any unexecuted *setting* or *operational commands*. Front panel controls that only change the display (like INST ID) do not affect the remote-local states—only front panel controls that change settings assert *rtl*. The *rtl* message remains asserted while multiple keystroke settings are entered; and it is unasserted after the execution of the settings. Since *rtl* prevents transitions to REMS, the instrument unasserts *rtl* if a multiple button sequence is not completed in a reasonable length of time (approximately 5 to 10 seconds).

The instrument maintains a record of its settings in the Current Settings Buffer and new settings from the front panel or the controller update these recorded settings. In addition, the front panel is updated to reflect setting changes due to commands. Instrument settings are unaffected by transitions between the four remote-local states. The REMOTE indicator is illuminated when the instrument is in REMS or RWLS.

Local State (LOCS)

In LOCS, instrument settings are controlled by the operator via front panel push buttons. When in LOCS, only bus commands that do not change instrument settings are executed (*query-output commands*); all other bus commands (*setting and operational*) generate an error since their functions are under front-panel control.

Local With Lockout State (LWLS)

The instrument operates the same as it does in LOCS, except that *rti* will not inhibit a transition to remote.

Remote State (REMS)

In this state, the instrument executes all instrument commands. For commands having front panel indicators, the front panel is updated when the commands are executed.

Remote With Lockout State (RWLS)

Instrument operation is identical to REMS operation except that the *rti* message is ignored.

STATUS AND ERROR REPORTING

Through the Service Request function (defined in the IEEE-488 Standard), the instrument may alert the controller that it needs service. This service request is also a means of indicating that an event (a change in status or an error) has occurred. To service a request the controller performs a Serial Poll; in response the instrument returns a Status byte (STB), which indicates whether it was requesting service or not. The STB can also provide a limited amount of information about the request. The format of the information encoded in the STB is given in Fig. 3-2.

When data bit 8 is set, the STB conveys Device Status information that is indicated by bits 1 through 4. Bit 4 is set if the DM 5010 is waiting for a trigger; bit 3 set indicates a reading is available.

Because the STB conveys limited information about an event, the events are divided into classes: the Status Byte reports the class. The classes of events are defined as follows:

COMMAND ERROR Indicates the instrument has received a command that it cannot understand.

EXECUTION ERROR Indicates that the instrument has received a command that it cannot execute. This is caused by arguments out of range or settings that conflict.

INTERNAL ERROR Indicates that the instrument has detected a hardware condition or firmware problem that prevents operation.

SYSTEM EVENTS Events that are common to instruments in a system (e.g., Power on, User Request, etc.).

INTERNAL WARNING Internal warning indicates that the instrument has detected a problem. The instrument remains operational, but the problem should be corrected (e.g., out of calibration).

DEVICE STATUS Device dependent events.

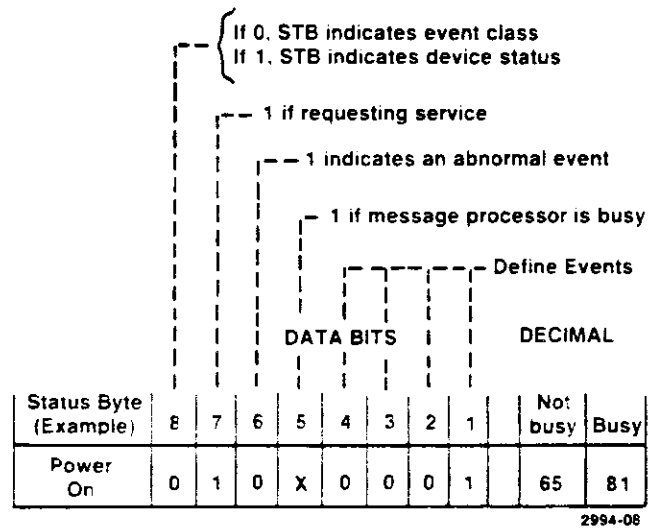

Fig. 3-2. Definition of STB bits.

The instrument can provide additional information about many of the events, particularly the errors reported in the Status Byte. After determining that the instrument requested service (by examining the STB) the controller may request the additional information by sending error query (ERR?). In response, the instrument returns a code which defines the event. These codes are described in Table 3-1.

Table 3-1
ERROR QUERY AND STATUS INFORMATION

| Abnormal Events | Error Query Response | Serial Poll Response ^a |
|---|----------------------|-----------------------------------|
| Command Errors: | | |
| Invalid command header | 101 | 97 |
| Header delimiter error | 102 | 97 |
| Argument error | 103 | 97 |
| Argument delimiter error | 104 | 97 |
| Missing argument | 106 | 97 |
| Invalid message unit delimiter | 107 | 97 |
| Execution Errors: | | |
| Not executable in local mode | 201 | 98 |
| Settings lost due to <i>rtI</i> | 202 | 98 |
| Input and output buffers full | 203 | 98 |
| Argument out of range | 205 | 98 |
| Group Execute Trigger ignored | 206 | 98 |
| Not in calibrate mode | 231 | 98 |
| Beyond calibration or null capability | 232 | 98 |
| Internal Errors: | | |
| Interrupt fault | 301 | 99 |
| System error | 302 | 99 |
| Math pack error | 303 | 99 |
| Converter time-out | 311 | 99 |
| Front panel time-out | 317 | 99 |
| Bad ohms calibration constant | 318 | 99 |
| Calibration checksum error | 351 | 99 |
| Normal Events | | |
| System Events: | | |
| Power on | 401 | 65 |
| Operation complete | 402 | 66 |
| ID user request | 403 | 67 |
| Internal Warning: | | |
| Over-range | 601 | 102 |
| Device Status^b: | | |
| Reading available | 0 | 132 |
| Waiting for trigger | 0 | 136 |
| Reading available and waiting for trigger | 0 | 140 |
| Below limits | 701 | 193 |
| Above limits | 703 | 195 |
| No Errors or Events | 0 | 128 |

^aIf the instrument is busy, it returns a decimal number 16 higher than the number listed.

^bThe 4050-Series controller POLL command returns 0 for serial poll responses between 128 and 192; the responses listed can be obtained by using WBYTE and RBYTE statements.

Table 3-2
FRONT-PANEL ERROR CODES

| Displayed | Abnormal Events | |
|--------------------------|---|------|
| Execution Errors: | | |
| 205 | Argument out of range | |
| 231 | Not in calibrate mode | |
| 232 | Beyond calibration capability | |
| Internal Errors: | | |
| 303 | Math pack error | |
| 311 | Converter time-out | |
| 317 | Front panel time-out | |
| 318 | Bad ohms calibration constant | |
| 340 | RAM error (high nibble) | |
| 341 | RAM error (low nibble) | |
| 351 | Calibration checksum error | |
| 372 | ROM placement error | C000 |
| 373 | ROM placement error | D000 |
| 374 | ROM placement error | E000 |
| 392 | ROM checksum error | C000 |
| 393 | ROM checksum error | D000 |
| 394 | ROM checksum error | E000 |
| 395 | ROM checksum error | F000 |
| 521 | Indicates GPIB address switch (Signature Analysis) is enabled | |

If there is more than one event to be reported, the instrument re-asserts SRQ until it reports all events. Each event is automatically cleared when it is reported via Serial Poll. The Device Clear (DCL) interface message may be used to clear all events except power-on.

Commands are provided to control the reporting of some individual events and to disable all service requests. For example, the User Request command (USER) provides individual control over the reporting of the user request event, which occurs when the front panel INST ID button is pushed. The Request for Service command (RQS) controls whether the instrument reports any events with SRQ.

RQS OFF inhibits all SRQ's, (except the power-on SRQ) so in this mode the ERR? query allows the controller to find out about events without first performing a Serial Poll. With RQS OFF, the controller may send the ERR? query at any time and the instrument returns an event waiting to be reported. The controller can clear all events by sending the error query until a zero (0) code is returned, or clear all events except power-on through the DCL interface message.

With RQS OFF the controller may perform a Serial Poll, but the Status Byte only contains Device Dependent Status information. With RQS ON, the STB contains the class of the event and a subsequent error query returns additional information about the previous event reported in the STB.

SENDING INTERFACE COMMANDS

The controller commands in the following text are for TEKTRONIX 4050-Series Controllers; they are representative of commands for other controllers.

Instrument commands are sent to the DM 5010 in ASCII using controller PRINT statements. The DM 5010 outputs data in response to INPUT statements from the controller. For example:

```
PRINT @ 16:"SET?"
INPUT @ 16:A$
```

where 16 is the DM 5010 primary GPIB address.

Interface control messages may be sent to the DM 5010 using WBYTE controller commands. In the following examples, A and B are the DM 5010 talk and listen addresses. For A, substitute the instrument primary address plus 32; for B, substitute the instrument primary address plus 64.

| | |
|-----------------------------|---------------|
| Listen (MLA) | WBYTE @ A: |
| Unlisten (UNL) | WBYTE @ 63: |
| Talk (MTA) | WBYTE @ B: |
| Untalk (UNT) | WBYTE @ 95: |
| Device Clear (DCL) | WBYTE @ 20: |
| Selected Device Clear (SDC) | WBYTE @ A,4: |
| Go To Local (GTL) | WBYTE @ A,1: |
| Remote With Lockout (RWLS) | WBYTE @ A,17: |
| Local With Lockout (LWLS) | WBYTE @ 17: |
| Group Execute Trigger <GET> | WBYTE @ A,8: |
| Serial Poll Enable (SPE) | WBYTE @ 24: |
| Serial Poll Disable (SPD) | WBYTE @ 25: |

Refer to the 4050-Series Controller manual for information on using RBYTE statements.

POWER-ON (INITIAL) CONDITIONS

At power on, the DM 5010 microprocessor performs a diagnostic routine (self-test) to check the functionality of the ROM and RAM. If no error is found, the instrument enters the Local State (LOCS) with the settings listed in Table 3-3. The SRQ line on the GPIB is also asserted.

The DM 5010 also assumes the settings in Table 3-3 when it executes the INIT command. The range setting for the DCV function is valid only for the first reading, since the instrument is in auto-range.

Table 3-3
DM 5010 POWER ON SETTINGS

| Header | Argument |
|---------|----------|
| AVE | 2 |
| CALC | OFF |
| DBR | 1 |
| DCV | -1.E+3 |
| DIGIT | 4.5 |
| DT | OFF |
| LFR | OFF |
| LIMITS | 0,0 |
| MODE | RUN |
| MONITOR | OFF |
| NULL | 0 |
| OPC | OFF |
| OVER | OFF |
| RATIO | 1,0 |
| RQS | ON |
| SOURCE | FRONT |
| USER | OFF |

ASCII & IEEE 488 (GPIB) CODE CHART

| BITS | | | | 0 0 | | 0 1 | | 1 0 | | 1 1 | |
|------|----|----|----|---------|--------|---------|-------|------------|---------|------------|-----------|
| B7 | B6 | B5 | B4 | CONTROL | | NUMBERS | | UPPER CASE | | LOWER | |
| B3 | B2 | B1 | B0 | | | | | | | | |
| 0 | 0 | 0 | 0 | 0 NUL | 20 DLE | 40 SP | 60 0 | 100 @ | 120 P | 140 \ | 160 p |
| 0 | 0 | 0 | 1 | 1 SOH | 21 DC1 | 41 ! | 61 1 | 101 A | 121 Q | 141 a | 161 q |
| 0 | 0 | 1 | 0 | 2 STX | 22 DC2 | 42 " | 62 2 | 102 B | 122 R | 142 b | 162 r |
| 0 | 0 | 1 | 1 | 3 ETX | 23 DC3 | 43 # | 63 3 | 103 C | 123 S | 143 c | 163 s |
| 0 | 1 | 0 | 0 | 4 EOT | 24 DC4 | 44 \$ | 64 4 | 104 D | 124 T | 144 d | 164 t |
| 0 | 1 | 0 | 1 | 5 ENQ | 25 NAK | 45 % | 65 5 | 105 E | 125 U | 145 e | 165 u |
| 0 | 1 | 1 | 0 | 6 ACK | 26 SYN | 46 & | 66 6 | 106 F | 126 V | 146 f | 166 v |
| 0 | 1 | 1 | 1 | 7 BEL | 27 ETB | 47 ' | 67 7 | 107 G | 127 W | 147 g | 167 w |
| 1 | 0 | 0 | 0 | 8 BS | 28 CAN | 48 (| 68 8 | 108 H | 128 X | 148 h | 168 x |
| 1 | 0 | 0 | 1 | 9 HT | 29 EM | 49) | 69 9 | 109 I | 129 Y | 149 i | 169 y |
| 1 | 0 | 1 | 0 | 10 LF | 30 SUB | 50 * | 70 : | 110 J | 130 Z | 150 j | 170 z |
| 1 | 0 | 1 | 1 | 11 VT | 31 ESC | 51 + | 71 ; | 111 K | 131 [| 151 k | 171 { |
| 1 | 1 | 0 | 0 | 12 FF | 32 FS | 52 , | 72 < | 112 L | 132 \ | 152 l | 172 |
| 1 | 1 | 0 | 1 | 13 CR | 33 GS | 53 - | 73 = | 113 M | 133] | 153 m | 173 } |
| 1 | 1 | 1 | 0 | 14 SO | 34 RS | 54 . | 74 > | 114 N | 134 ^ | 154 n | 174 ~ |
| 1 | 1 | 1 | 1 | 15 SI | 35 US | 55 / | 75 ? | 115 UNL | 135 UNT | 155 RUBOUT | 175 (DEL) |
| | | | | 16 E | 36 1E | 56 2E | 76 3E | 116 4E | 136 5E | 156 6E | 176 7E |
| | | | | 17 F | 37 1F | 57 2F | 77 3F | 117 4F | 137 5F | 157 6F | 177 7F |

ADDRESSED COMMANDS

UNIVERSAL COMMANDS

LISTEN ADDRESSES

TALK ADDRESSES

SECONDARY ADDRESSES OR COMMANDS

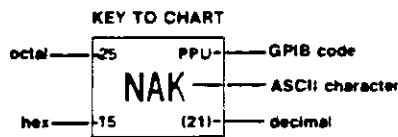

3391-13

Fig. 3-3. ASCII and IEEE 488 (GPIB) Code Chart.

Example Programs

Talker Listener Program For TEKTRONIX 4050-Series
Controllers

```

100 REM DM5010 Talker/Listener Program
110 REM DM5010 Primary Address = 16
120 INIT
130 ON SRQ THEN 260
140 DIM A$(200)
150 PRINT "Enter Message(s): ";
160 INPUT C$
170 PRINT @16:C$
180 REM Check for queries
190 IF POS(C$,"?",1)<>0 THEN 220
200 REM Check for 'SEND'
210 IF POS(C$,"SEND",1)=0 THEN 150
220 REM Input from device
230 INPUT @16:A$
240 PRINT A$
250 GO TO 150
260 REM Serial POLL Routine
270 POLL X,Y:16
280 PRINT "Status Byte: ";Y
290 RETURN
    
```

These sample programs allow a user to send instrument commands to the DM 5010 to change instrument settings and to return the data generated.

Additional assistance in developing specific application oriented software is available in the following Tektronix manuals.

070-3985-00—GPIB Programming Guide. This manual is specifically written for applications of this instrument in IEEE-488 systems. It contains programming instructions, tips, and some specific example programs.

070-2270-00—4051 GPIB Hardware Support Manual. This manual gives an in-depth discussion of IEEE-488 bus operation, explanations of bus timing details and early bus interface circuitry.

Talker Listener Program For TEKTRONIX 4040-Series
Controllers

```

100 Rem DM5010 TALKER/LISTENER PROGRAM
110 Rem PRIMARY ADDRESS = 16
120 Init all
130 On srq then gosub srqhdl
140 Enable srq
150 Dim respons$ to 200
160 Input prompt "ENTER MESSAGE(S): ":message$
170 Print #16:message$
180 Rem CHECK FOR QUERIES
190 If pos(message$,"?",1) then goto 280
200 Rem CHECK FOR 'SEND' COMMAND
210 If pos(message$,"SEND",1) then goto 280
220 Rem CHECK FOR 'TEST' COMMAND
230 If pos(message$,"TEST",1) then goto 280
240 Rem CHECK FOR 'DATA' COMMAND
250 If pos(message$,"DATA",1) then goto 280
260 Goto 160
270 Rem INPUT FROM DEVICE
280 Input #16:respons$
290 Print "RESPONSE: ";respons$
300 Goto 160
310 Rem SERIAL POLL ROUTINE
320 Srqhdl: poll stb,pri
330 Print "STATUS BYTE: ";stb
340 Resume
350 End
    
```

070-2058-01—Programming in BASIC

070-2059-01—Graphic programming in BASIC

062-5971-01—4050-Series programming aids, T1 (includes software)

062-5972-01—4050-Series programming aids, T2 (includes software)

070-2380-01—4907 File manager operators manual

070-2128-00—4924 Users manual

070-1940-01—4050-Series graphic system operators manual

070-2056-01—4050-Series graphic system reference manual

070-3918-00—4041 Operators manual

061-2546-00—4041 Programming reference manual

PROGRAMMING AIDS

This discussion of programming considerations and the program examples are provided to aid in developing programs to control the DM 5010. The program examples were designed using a TEKTRONIX 4050-Series controller and the DM 5010; some examples also use other TM 5000 programmable instruments.

An initial programming consideration is setting the DM 5010 message terminator, GPIB address, and Talk Only mode switches. To determine their settings, press the INST ID button. The number displayed is the selected GPIB primary address; the far right decimal illuminates if the LF/EOI message terminator is selected; the minus sign illuminates if the Talk Only mode is selected. To change switch settings, refer qualified service personnel to the Maintenance section of this manual.

In the program examples, variable D is assigned to the DM 5010 GPIB primary address, which is assumed to be set to decimal 16. Using a variable name eliminates repeating the address decimal number and allows the address in the program to be easily changed.

Handling Service Requests

At power-on, the DM 5010 asserts SRQ. The power-on SRQ is incorporated to inform the controller if the power source is interrupted during program operation, since it may interfere with proper program execution. The DM 5010 can also assert SRQ for other events, if SRQ is enabled (see Table 3-1, Error Query and Status Information). Some controllers have the capability of ignoring SRQs; the other controllers require servicing all SRQs. If SRQs are to be serviced in the program, be sure to enable its interrupt.

Interrupt Handler—an interrupt driven routine to service SRQs when they occur during program operation. An interrupt handler basically consists of an ON SRQ statement in the beginning of the program, and a serial poll routine somewhere in the program. The ON SRQ statement directs program control to the serial poll routine when an SRQ occurs. See program example 1 or 3, line 110 for ON SRQ statements. When an SRQ interrupt occurs, the controller performs the serial poll routine. In a POLL statement, the first variable returns the instruments position in the list of GPIB addresses; the second variable returns the status byte. A serial poll of one instrument on the bus is illustrated in example 3, line 1000. Line 400 in example 4 polls three instruments on the bus, using the variable names for each instrument address. In each example, the POLL returns the status byte from the instrument asserting SRQ. Program example 9, lines 150, 160, and 170 comprise a serial poll using 4050-Series WBYTE and RBYTE statements.

The serial poll routine can be expanded to decode information about the event causing the SRQ. In example 1, lines 510 and 520 clear the busy bit in the status byte; lines 530 through 560 decode the status byte, and lines 1000 through 7030 print the event class on the controller display.

Program example 7 uses the MONITOR SRQ to detect measurements above or below limits set by the LIMITS command, or overrange. Lines 1020, 1040, and 1045 decode the status byte and initiate the appropriate print out on the controller display.

In program example 2, line 130, the controller polls the instrument at address 16 to clear the power-on SRQ. Line 160 turns SRQ off to inhibit additional SRQs. After SRQ OFF, the ERR? query may be inserted in the program where it is necessary to determine an event state.

Front Panel Lockout

The front panel may be locked out so that only the controller may change instrument settings. To lock out the front panel, first assert REN (true). REN must remain true as long as lock out is desired. For 4050-Series controllers, the RUN statement automatically asserts REN; the END statement unasserts REN. Then send the interface message LLO (decimal 17 with ATN). This is done in the 4050-Series controller with the WBYTE statement. Finally, address the instrument by sending a setting or query command using a PRINT @D: statement or send only the listen address using a WBYTE statement. After these three steps, the front panel is locked out and remains so until REN goes false or a <GTL> message (decimal 1 with ATN) is sent. See program example 4, lines 150 and 190; and example 5, lines 130 and 220.

Using INIT

Using the INIT command simplifies the program because it usually takes fewer commands to set the instrument state than specifying all settings individually. In program example 6, line 150, the DM 5010 receives the INIT command, followed by a series of commands that change the instrument state from the INIT (power-on) settings to the desired state.

Invalidating a Pending Reading

Following a change to the applied input, it may be desirable to invalidate the pending reading since it no longer reflects the current measurement conditions. One way to invalidate a pending reading is to send the instrument a setting command—this causes the instrument to delete data in the output buffer. Another way is to input a reading to the controller and ignore it.

Invalid readings can be avoided by using MODE TRIG to control when readings are taken.

Allowing Settling Time

Settling time may be incorporated in a program to ensure that the reading returned to the controller is valid. Refer to Step Response Time in the Specification section of this manual.

In program example 4, lines 230-250 use a FOR...NEXT loop to input five readings into variable R. At the end of the loop, variable R contains the fifth reading.

In program example 5, lines 290-320, two DM 5010 readings are compared; if the difference is greater than 0.001, another reading is taken for comparison. Comparisons are repeated until the difference indicates two readings are nearly the same.

Triggering Measurements

To trigger a single conversion, use MODE TRIG and initiate a trigger by using one of the following:

1. Talk-address the instrument. See program example 2 line 180.
2. SEND command.
3. Send DT TRIG. Then trigger the DM 5010 by transmitting a Group Execute Trigger (GET) interface message (decimal 8 with ATN). Refer to program example 9, lines 120 and line 5.
4. If the EXTRIG mode is enabled, hold P1031-16A on the Isolation board low for 10 μ s or less.
5. Instruct the operator to press the front-panel TRIGGERED button.

For repetitive (free-run) triggering, use the MODE RUN command. If the EXTRIG mode is enabled, hold P1031-16A on the Isolation board low.

Determining Reading Availability

It is not necessary to determine if a reading is available when the instrument is talk addressed or when the SEND command is used to return data. For either of these retrieval methods, the instrument triggers a conversion if a reading is not pending.

For other retrieval methods, there are several ways to determine if a reading is available.

1. Send the RDY? query command. When the response is 1, a reading is ready. See program example 3, line 140.
2. Set OPC ON and RQS ON. The instrument asserts SRQ when a reading is available. See example 8, line 150.
3. Repeat a serial poll routine using the WBYTE statements until the status byte is 132, 148, 140, or 156. See example 9, lines 150 and 200.

The RDY?, OPC ON and serial poll routine are useful when several tasks are going on at the same time.

Sending Readings to a Listener

To transfer a DM 5010 reading to a GPIB listener, the instrument that is to receive the data must be listen addressed. Then talk address the DM 5010 to transmit readings. When sent to a controller, data can be read into a string or numeric variable. See programming examples 2, line 180, and 3, line 150.

Program Example 1:

```

1 REM INTERACTIVE DRIVER WITH STATUS BYTE DECODER FOR DMS010
99 REM D = ADDRESS OF DMS010
100 D=16
110 ON SRQ THEN 500
120 PRINT @16:"INIT;USER ON;OVER ON"
130 PRINT "ENTER DMS010 COMMAND: ";
140 INPUT A$
150 PRINT @D:A$
159 REM GET QUERY RESPONSE OR READING FROM DMS010
160 INPUT @D:A$
170 PRINT A$
200 GO TO 130
499 REM SERVICE REQUEST INTERRUPT SUBROUTINE
500 POLL X,Y;D
509 REM CLEAR BUSY BIT
510 IF Y/32-INT(Y/32)<0.5 THEN 530
520 Y=Y-16
529 REM DECODE STATUS BYTE
530 IF Y=102 THEN 6010
540 GO TO Y-192 OF 7010,550,7030
550 GO TO Y-64 OF 4010,4020,4030
560 GO TO Y-96 OF 1000,2000,3000
570 PRINT Y;" IS AN INVALID STATUS BYTE FOR DMS010"
580 RETURN
1000 PRINT "COMMAND ERROR"
1009 RETURN
2000 PRINT "EXECUTION ERROR"
2009 RETURN
3000 PRINT "INTERNAL ERROR"
3009 RETURN
4010 PRINT "POWER ON"
4019 RETURN
4020 PRINT "OPERATION COMPLETE"
4029 RETURN
4030 PRINT "USER REQUEST"
4039 RETURN
6010 PRINT "OVER-RANGE"
6019 RETURN
7010 PRINT "BELOW LIMITS"
7019 RETURN
7030 PRINT "ABOVE LIMITS"
7039 RETURN

```

Program Example 2:

```

1 REM PROGRAM TO ECHO READINGS FROM DMS010 ONTO CONTROLLER DISPLAY
2 REM ASSUME USER WILL SET DMS010 TO PROPER FUNCTIONS VIA FRONT PANEL
100 REM D = ADDRESS OF DMS010
110 D=16
120 REM READ SERVICE REQUESTS
130 POLL X,Y;D
140 IF X THEN 130
150 REM DISABLE ALL OTHER SERVICE REQUESTS
160 PRINT @16:"RQS OFF"
170 REM INPUT READING FROM DMS010
180 INPUT @D:R$
190 REM CHECK FOR ERROR
200 PRINT @D:"ERR?"
210 INPUT @D:E$
220 IF E$="ERR 0;" THEN 240
230 PRINT E$;
240 PRINT R$
250 GO TO 180

```

Program Example 3:

```
1 REM READY QUERY
100 REM D = ADDRESS OF DM5010
101 D=16
110 ON SRQ THEN 1000
115 PRINT @D:"INIT"
120 PRINT "WAITING FOR READING"
130 PRINT "WAITING FOR READING"
140 PRINT @D:"RDY?"
150 INPUT @D:G
160 IF NOT(G) THEN 130
169 REM INPUT READING FROM DM5010
170 INPUT @D:R
180 PRINT "READING IS ";R
190 GO TO 120
999 REM SERVICE REQUEST INTERRUPT SUBROUTINE
1000 POLL X,Y;D
1010 RETURN
```

Program Example 4:

```
1 REM GAIN VS FREQUENCY USING DM5010, FG5010 AND SI5010
100 ON SRQ THEN 400
110 D=16
120 F=24
130 S=26
140 REM SEND LLO (LOCAL LOCKOUT)
150 WBYTE @17:
160 PRINT "FREQUENCY (HZ)    AMPLITUDE (DB)"
170 REM H = FREQUENCY IN HZ
180 H=10
190 PRINT @D:"INIT;ACV"
200 PRINT @F:"INIT;AMPL 1;OUTPUT ON;FREQ ";H
210 PRINT @S:"INIT;CONF 0,8,0,8;CLOSE 4"
220 REM WAIT FOR FG, TEST CIRCUIT AND DM TO SETTLE
230 FOR K=1 TO 5
240 INPUT @D:R
250 NEXT K
260 REM R = INPUT VOLTAGE TO TEST CIRCUIT
270 PRINT @D:"CALC DBR;DBR ";R
280 PRINT @S:"INIT;CLOSE 1,4,5"
290 REM WAIT FOR SI5010 AND DM5010 AC CONVERTER TO SETTLE
300 FOR K=1 TO 5
310 INPUT @D:R1
320 NEXT K
330 REM R1 = TEST CIRCUIT GAIN IN DB
340 PRINT H,R1
350 REM STEP FREQUENCY AND REPEAT MEASUREMENT
360 H=10*H
370 IF H<=100000 THEN 190
380 END
390 REM SERVICE REQUEST INTERRUPT SUBROUTINE
400 POLL X,Y;D;F;S
410 RETURN
```

Program Example 5:

```

1 REM GAIN VS FREQUENCY USING DMS010 AND A MANUAL FG
98 INIT
99 REM D = ADDRESS OF DMS010, S = ADDRESS OF SIS010
100 D=16
105 S=26
110 ON SRQ THEN 480
120 REM SEND LLO (LOCAL LOCKOUT)
130 WBYTE @17:
140 PRINT "PLEASE APPLY THE FOLLOWING FREQUENCY, ";
150 PRINT "THEN PRESS THE INSTRUMENT ID BUTTON ON THE DMS010"
160 PRINT "FREQUENCY (HZ)    AMPLITUDE (DB)"
170 REM H = FREQUENCY IN HZ
180 H=10
190 REM V IS A FLAG THAT IS CLEARED WHEN USER PUSHES ID BUTTON ON DMS010
200 V=1
210 REM FRONT INPUT OF DM IS CONNECTED TO THE FG OUTPUT
220 PRINT @D:"INIT;ACV;USER ON;LFR ON"
230 PRINT @26:"CONF 0,8,0,8;CLOSE 4;RQS OFF"
240 PRINT H,"";
250 REM WAIT FOR USER TO SET FG FREQUENCY AND PUSH DMS010 INST ID BUTTON
260 IF V THEN 250
270 REM WAIT FOR FG, TEST CIRCUIT AND DMS010 TO SETTLE BY TAKING
280 REM READINGS UNTIL TWO READINGS ARE WITHIN 0.1% OF EACH OTHER
290 INPUT @D:R
300 R1=R
310 INPUT @D:R
320 IF ABS(R-R1)>R*1.0E-3 THEN 300
330 REM R HAS VALUE OF INPUT TO TEST CIRCUIT
340 PRINT @26:"CONF 4,4,4,4;CLOSE 1,5"
350 PRINT @D:"CALC DBR;DBR ";R
360 REM WAIT FOR TWO CONSECUTIVE READINGS WITHIN 0.1% OF EACH OTHER
370 INPUT @D:R
380 R1=R
390 INPUT @D:R
400 IF ABS((R-R1)/R)*1.0E-3 THEN 380
410 REM R HAS TEST CURCUIT'S GAIN IN DB
420 PRINT R
430 REM CHANGE FREQUENCY AND REPEAT MEASUREMENT
440 H=10*H
450 IF HK=100000 THEN 200
460 END
470 REM SEVRICE REQUEST INTERRUPT SUBROUTINE
480 POLL X,Y;D;S
490 REM CHECK FOR USER REQUEST INTERRUPT GENERATED BY PUSHING INST ID
500 IF Y=67 OR Y=83 THEN 530
510 RETURN
520 REM CLEAR FLAG TO INDICATE THAT USER HAS PUSHED ID BUTTON
530 V=0
540 RETURN

```

Program Example 6:

```
1 REM DAC TEST USING DM5010 AND MI5010 WITH 50M30 DIGITAL I/O CARD
99 REM D = ADDRESS OF DM5010, M = ADDRESS OF MI5010, C = CARD SLOT
100 D=16
110 M=23
120 C=1
130 ON SRQ THEN 1000
140 DIM R(256)
150 PRINT @D:"INIT;DCV 20;MODE TRIG;DIGIT 3.5"
160 PRINT @M:"INIT;SEL ";C;";CHA 1"
170 FOR K=0 TO 255
179 REM OUTPUT K TO DAC UNDER TEST
180 PRINT @M:"DATA ";K;";DATA?"
189 REM WAIT FOR MI5010 TO SETTLE BY READING RESPONSE TO DATA QUERY
190 INPUT @M:K$
199 REM TRIGGER DM5010 AND READ VOLTAGE FROM DAC UNDER TEST
200 INPUT @D:R(K+1)
210 NEXT K
220 REM DATA IN ARRAY R IS READY FOR PROCESSING
230 END
999 REM SERVICE REQUEST INTERRUPT SUBROUTINE
1000 POLL X,Y;D;M
1010 RETURN
```

Program Example 7:

```
1 REM MONITOR LINE VOLTAGES
99 REM D = ADDRESS OF DM5010
100 D=16
110 ON SRQ THEN 1000
120 PRINT @D:"INIT;ACV;LIMITS 105,120;MONITOR ON"
130 REM PLACE MAIN PROGRAM HERE
150 GO TO 130
160 END
999 REM SERVICE REQUEST INTERRUPT SUBROUTINE
1000 POLL X,Y;D
1005 PRINT Y
1009 REM TEST STATUS BYTE FOR BELOW LIMITS
1010 Z$="BELOW"
1020 IF Y=193 OR Y=209 THEN 1060
1029 REM TEST FOR ABOVE LIMITS
1030 Z$="ABOVE"
1040 IF Y=195 OR Y=211 THEN 1060
1044 REM TEST FOR OVERRANGE
1045 IF Y=102 OR Y=118 THEN 1110
1050 RETURN
1060 PRINT @D:"DATA"
1070 INPUT @D:W
1080 PRINT W;" IS ";Z$;" LIMITS"
1090 RETURN
1110 PRINT "OVER-RANGE"
1120 RETURN
```

Program Example 8:

```

1 REM AN EXAMPLE OF DOING TWO UNRELATED TASKS
2 REM MAIN PROGRAM LISTS A TAPE FILE ONTO A PRINTER AT ADDRESS P
3 REM INTERRUPT SUBROUTINE FINDS MAXIMUM VOLTAGE USING DMS010
100 INIT
109 REM D = ADDRESS OF DMS010, P = ADDRESS OF PRINTER
110 D=16
115 P=40
120 ON SRQ THEN 1000
130 PRINT @D:"INIT"
140 INPUT @D:M
150 PRINT @D:"OPC ON"
160 PRINT "ENTER FILE NUMBER TO BE LISTED"
170 INPUT F
180 FIND F
190 E=1
200 ON EOF (0) THEN 500
210 GO TO 230
220 PRINT @40:A$
230 INPUT @33:A$
240 IF E THEN 220
250 PRINT "DONE WITH FILE ";F
260 PRINT "MAX VOLTAGE IS ";M
270 GO TO 160
499 REM END OF FILE INTERRUPT SUBROUTINE
500 E=0
510 RETURN
999 REM SERVICE REQUEST INTERRUPT SUBROUTINE
1000 POLL X,Y;D
1009 REM TEST FOR OPERATION COMPLETE
1010 IF Y=66 OR Y=82 THEN 1030
1020 RETURN
1029 REM INPUT READING FROM DM AND COMPARE TO PREVIOUS MAXIMUM
1030 INPUT @D:M1
1040 IF M1<=M THEN 1060
1049 REM NEW READING IS NEW MAXIMUM
1050 M=M1
1060 RETURN

```

Program Example 9:

```

1 REM POLL FOR NORMAL DEVICE DEPENDENT STATUS
3 GO TO 100
4 REM USER DEFINABLE KEY #1 SENDS GROUP EXECUTE TRIGGER TO DMS010
5 WBYTE @D+32,8,63:
7 RETURN
19 REM USER DEFINABLE KEY #5 DOES AN ERROR QUERY
20 PRINT @D:"ERR?"
21 INPUT @D:A$
22 PRINT
23 PRINT A$
24 RETURN
99 REM D = ADDRESS OF DMS010
100 D=16
109 REM DO SERIAL POLL TO CLEAR POWER ON SERVICE REQUEST
110 POLL X,Y;D
119 REM DISABLE SERVICE REQUESTS
120 PRINT @D:"INIT;DT TRIG;RQS OFF"
129 REM S = PREVIOUS STATUS, S1 = PRESENT STATUS
130 S=0
140 S1=S
144 REM DO SERIAL POLL WITH WBYTE TO GET DEVICE DEPENDENT STATUS
145 SET NOKEY
150 WBYTE @24,D+64:
160 RBYTE S
170 WBYTE @25,95:
175 SET KEY
178 REM IF NEW STATUS IS SAME AS OLD STATUS THEN PRINT VERTICAL TAB
179 REM SO THAT STATUS MESSAGE WILL APPEAR BRIGHT
180 IF S<>S1;THEN 200
190 PRINT "K";
198 REM DECODE STATUS BYTE
199 REM TEST FOR READING READY
200 IF S=132 OR S=148 OR S=140 OR S=156 THEN 300
209 REM TEST FOR WAITING FOR TRIGGER
210 IF S=136 OR S=152 THEN 250
219 REM TEST FOR CONVERSION IN PROGRESS
220 IF S=128 OR S=144 THEN 280
230 PRINT S;" UNEXPECTED STATUS BYTE"
240 GO TO 140
250 PRINT S;" WAITING FOR TRIGGER"
270 GO TO 140
280 PRINT S;" CONVERSION IN PROGRESS"
290 GO TO 140
300 INPUT @D:R
310 PRINT S;" READING IS ";R
320 GO TO 140

```

THEORY OF OPERATION

BLOCK DIAGRAM DESCRIPTION

This discussion is provided to aid in understanding the overall concept of the DM 5010 Programmable Digital Multimeter. The basic block diagram of the DM 5010 in Section 10, Diagrams and Circuit Board Illustrations, should be followed when reading the Block Description.

General Description

The DM 5010 Programmable Digital Multimeter is a microprocessor based GPIB programmable instrument designed to operate in any two adjacent compartments of a TM 5000-Series power module. It has dual-polarity floating-voltage measurement capabilities as well as the ability to offset or null resistance and voltage measurements under user control. It uses a charge balancing technique to convert the analog input signals to digital data for storage and processing.

To understand how the DM 5010 functions, some concepts and techniques implemented in the instrument are explained at this point. These concepts should be understood before proceeding to the block diagram and detailed circuit descriptions in this section.

Isolation

The floating measurement capability allows the DM 5010 to accurately measure voltages referenced to a point other than DMM chassis ground. To accomplish this, the DM 5010 implements an isolation scheme. The TM 5000 power module supplies power to the analog and isolated sections through a transformer to electrically isolate it from the chassis ground. The required data and control signals to/from this section are transmitted via opto-isolators, completing the isolation scheme. Isolating the "front-end", where the critical portion of the measurement process occurs, from chassis ground eliminates many problems inherent in ground-related measurement techniques.

Charge Balancing

The DM 5010 Programmable Digital Multimeter operates on the principle that each of its various measurement modes (dc volts, ac volts, Ohms, etc.) may, through proper input conditioning, be translated into a dc voltage representing the conditions present at the instruments inputs. After input conditioning, four major tasks remain:

1. conversion of the representative voltage to a digital form that may be stored and manipulated as necessary;
2. keeping track of measurement specifics (i.e., type, range, etc.);
3. performing any secondary conditioning or algorithms dependent on 2, above, and;
4. presenting the resultant measurement data to the user in a visible display or, if desired, to another device in some intelligent format.

The latter three functions are performed and controlled mostly by microprocessor and GPIB circuitry and are described more fully later in this section. In this instrument, the conversion of step 1 is performed using the charge-balancing A/D conversion technique.

Charge balancing conversion operates on the following principle. An unknown (voltage-dependent) current I_{in} injected into an integrator's input causes the integrator's output to charge away from its initial value at some unknown rate. Similarly, either injecting or removing a known net current $I_{net\ ref\ in}$ or $I_{net\ ref\ out}$ at the input node causes the integrators output to integrate down and up, respectively, at a known rate. If the unknown current and one of the known net currents (either injected or removed) are applied to the node simultaneously, the integrators output charges at a rate determined by the sum of the currents. If the reference currents $I_{net\ ref\ in}$ and $I_{net\ ref\ out}$ are chosen to always be greater in magnitude than any allowed value of I_{in} , the integrators output charges in the direction established by the reference current switched into the summing mode. Charge rate is established by $I_{net\ ref\ (in\ or\ out)} + I_{in}$.

A conversion is accomplished by keeping track of the time required in each of its $I_{net\ ref} + I_{in}$ charge modes to keep the integrators output near a predetermined zero-reference voltage. By attaching a comparator to the zero-reference voltage and to the output of the integrator, it may be determined whether the integrators output is above or below the zero-reference. By adding or subtracting clock pulses to a counter in response to the comparator output, a numerical representation of the net time required by $I_{net\ ref}$ to balance the effect of I_{in} on the integrator capacitor is generated. The system microprocessor translates the numerical results into a meaningful data format for display to the user.

Theory of Operation—DM 5010

At the beginning of a conversion, an Auto-Zero period is initiated in which a zero-reference voltage is stored by the converter. This voltage is compared to the output of the integrator during actual signal measurement and represents a zero-volt input.

After the zero reference has been established, the input current is switched into the node. This current and $I_{net\ ref\ out}$ cause the integrators output to integrate up toward the zero-reference voltage at a rate determined by $I_{net\ ref\ out} + I_{in}$. For input voltages \leq the full scale voltage, the integrator output will cross the zero-reference voltage in less than four measurement intervals. After the zero-reference voltage crossing and a new polarity determination is made, the control logic switches the reference current's direction (and thus the direction of integration).

The measurement interval consists of 18 clock cycles, which allow the integrators output to charge somewhat beyond the zero-reference voltage before charge direction is reversed. During this charging process, each clock is added to or subtracted from the contents of a counter depending on the output state of the comparator.

The integrators output now charges back toward the zero-reference at a rate determined by $I_{net\ ref\ in} + I_{in}$. It may take less than one or up to several hundred measurement intervals for the integrator output to again cross the zero-reference voltage. After the comparator detects the crossing and a new polarity determination is made, charge direction is reversed at the beginning of the next measurement interval. This process of charging toward the threshold, beyond the threshold, and then reversing direction to charge back toward the threshold repeats until the prescribed number of measurement intervals is complete. During this time, the accumulated count in the up/down counter is being added to or subtracted from, depending on the output state of the comparator (ICOMP). When the last measurement interval is complete, the accumulated clocks in the counter are representative of the A/D converters input.

Microprocessor

The implementation of a microprocessor in the DM 5010 substantially reduces its hardware requirements and increases its flexibility and capability. Microprocessor systems use bus-structured architecture. A general description follows.

At any given time in a microprocessor system, many "pieces" of information may be present at various physical locations within the system. This information may include the instructions for the microprocessor to perform some process, constants and algorithms for that process, intermediate and final results for the process, control and switch-

ing information, "locations" of certain information, etc. Of these types of information, most are stored (at least temporarily) in the form of "data" at an "address" or as some type of control signal or level.

The microprocessor uses busses to control the flow of data and program execution. A bus is a group of signal lines dedicated to a data transfer or program control function. It is connected to allow bidirectional data transfer or control over two or more devices using the same signal paths for any two of the transfers or control functions.

The data bus is the group of eight signal lines in the DM 5010, dedicated to transferring data in a standard format between the microprocessor and the other devices on the bus.

The address bus is another group of signal lines dedicated solely to "addressing" (selecting) the device that the microprocessor wants to communicate with (data transfer via the data bus). Address-decoding circuitry makes the devices on the data bus respond only to their proper address(es).

The remaining lines associated directly with the microprocessor IC (with the exception of power supply and clock signals) comprise the control bus. These signal lines allow the processor to control certain system functions and allow certain conditions within the system to alter processor operation.

The bus configuration employed in processor-oriented systems allows great flexibility when implementing hardware. Since system operation is under "firmware" control, functions that normally require large amounts of dedicated circuitry may be performed by a general block operating in several different modes.

Another characteristic of processor-oriented systems is the ability to perform calculations. Some parameters may not be measured directly with a multimeter, and a series of calculations must be performed to arrive at the desired result. The DM 5010 has the capability of performing some frequently used calculations, giving the user the ability to "directly" measure these parameters.

GPIB

The GPIB (General Purpose Interface Bus) circuitry of the DM 5010 provides a communication link to other GPIB compatible instruments. This communication link allows the DM 5010 to be programmed to operate in any of its measurement modes and then to transfer the results of that

measurement to any other assigned instrument on the GPIB bus. The DM 5010's GPIB circuitry adheres to IEEE Standard 488-1978 and will be described later in this section.

Block Description

The following block description uses the Block Diagram in Section 10 at the rear of this manual. Each major block of circuitry is assigned a name according to its primary function. The diamond numbers within a block represent the diagram(s) on which the complete circuit may be found. Only the basic interconnections between the individual blocks are shown.

As previously mentioned, the circuitry of the DM 5010 is divided into two distinct sections, depending on how the devices within each section receive their power. The block diagram indicates the division between the Grounded Section and the Isolated Section.

The power for the circuitry in the Grounded Section is derived from the Grounded Power Supplies. These supplies are powered from the TM 5000-Series power module and regulated to meet the requirements of the DM 5010.

The power required for the circuitry in the Isolated Section is transferred from the power module to the Isolated Power Supplies through a transformer. The Transformer Drive circuitry switches the power-module current through the transformer at a frequency synchronized to the analog-to-digital conversion process to minimize the noise error caused by power supply ripple in the Isolated Section.

Power is transferred to the Isolated Power Supplies, and the Isolated Regulators stage regulates the power to the levels required by the rest of the Isolated Section.

The Input Switch stage allows analog signals from either the front panel or the rear interface input to be selected for measurement.

The selected input is applied to either the DCV Signal Conditioner, RMS, or Ohms Converter circuits where the applied input is translated into a representative dc voltage. The Range Control circuitry provides the gain and attenuation switching necessary to accommodate the various ranges of the RMS, DCV Signal Conditioner, and Ohms circuits.

Depending on the mode of operation, the dc output from either the Input switch, RMS Converter, or Ohms Converter is applied to the DCV Signal Conditioner as determined by

the Function Switch. The Attenuator and DCV Signal Conditioner provide attenuation or gain factors and scale the input signal to fall within the A/D converters input range. The A/D converter uses a charge balancing conversion technique to convert the applied analog dc input to a corresponding digital equivalent.

As the conversion takes place, the A/D converter generates a count direction control signal defining the input conditions. As this signal is generated, it is transferred via an opto-isolator to the Grounded Section and is used to maintain control of the on-going conversion. The remaining opto-isolators transfer control information from the Grounded Section to the Isolated Section to set up the range switching and to control the A/D conversion process.

The microprocessor is the control center for all activity in the instrument. It is a time-dependent device and most functional blocks are synchronized to it, either directly or indirectly, shortly after power-up. The Timing Logic, together with the Control Logic, develops the proper time-dependent logic signals for the A/D conversion circuitry on both sides of the opto-isolators. The Timing Logic also drives the Transformer Drive circuitry at a rate that makes the A/D conversion most immune to power supply noise.

The Data circuitry consists of a counter that keeps track of clock pulses under the direction of the count-direction control signal generated during an A/D conversion. The signal originates in the A/D Converter in the Isolated Section and is passed through the opto-isolators and the Control Logic to the Data counter where it controls the count direction of an up/down counter. From there, this binary-coded counter data is transferred one bit at a time onto the data bus via the block labeled Miscellaneous Buffer. This sequential data string, representing the conditions at the instruments inputs, is read by the Microprocessor. Then the processor performs the manipulations necessary to bring it to the desired format for display or transfer over the GPIB.

With the exception of some front-panel circuitry and a battery circuit, the remainder of the circuitry in the instrument is directly connected to the microprocessor's address or data busses.

The Address Decode and Logic circuits decode certain addresses or groups of addresses output from the processor on its address bus. When output by the processor, they enable specific blocks of circuitry to communicate with the processor. There are many discrete enabling lines involved with the Address Decode; they are shown on the Block Diagram as being returned back onto the address bus. These enable lines may be thought of as an extension of the address bus. Due to the multiplicity of devices requiring micro-

Theory of Operation—DM 5010

processor addressing, an Address Bus Buffer stage is necessary to increase current drive capability.

The Data Bus Buffer serves much the same purpose but is bidirectional; i.e., it buffers data signals both from and to the microprocessor.

The ROM circuitry contains the instruments operational firmware that tells the Microprocessor how to control and perform instrument functions. Many functions the processor performs require some way to temporarily store data and read it back later. The RAM serves this purpose.

A special CMOS RAM is used to store "calibration constants" for the instrument. During adjustment of the instrument, specific signals are applied to its inputs and the microprocessor is "told" what the readings it is receiving from the D/A converter represent. Constants are derived from this data and are stored in the CMOS RAM. This memory may only be changed during the adjustment procedure. The Battery circuit connected to the CMOS RAM ensures that these constants are maintained when instrument power is turned off.

The Front-Panel Control block provides the circuitry necessary for the microprocessor to read information from the

user-selectable Front-Panel Switches as well as the ability to present measurement data and some status information back to the user via the Front-Panel Display. The Front-Panel Drive circuitry provides the current drive necessary to illuminate the various devices of the Front-Panel Display.

The GPIB (General Purpose Interface Bus) circuitry enables the DM 5010 to communicate with other GPIB-compatible instruments. By using an external controller, other GPIB instruments may receive measurement information from the DM 5010 or may send measurement related instructions to it. This allows the DM 5010 to change measurement modes and send the measurement results to a desired instrument without operator intervention.

When a GPIB controller addresses an instrument on the GPIB, the microprocessor looks at the DM 5010's Switches block to see if it is supposed to respond. These Switches may be set by the user to define which GPIB address the DM 5010 will recognize.

One of the Switches, when set, stops all normal operation of the DM 5010. This is its signature analysis mode, and signature analysis troubleshooting may be performed on the instrument. By disconnecting the Data Bus Buffer from the Microprocessor and connecting the NOP (no-operation) Buffer in its place, a more rudimentary form of troubleshooting may be performed.

DETAILED CIRCUIT DESCRIPTION

The following description provides detailed information about the circuitry of the DM 5010. The diamond number(s) preceding the individual descriptions indicate the specific diagram(s) being explained by that description.

INPUT SWITCH

The Input Switch determines whether the analog signal applied to the DM 5010's front-panel inputs or the signal from the analog inputs at its rear interface connector is measured. Depending on the range of the measurement being made, the input is attenuated by an appropriate factor to prescale the signal and protect the various input circuits from overvoltage conditions.

With no current through relay K1631, the front-panel inputs HIGH, LOW, and GUARD are selected for measure-

ment. Guard switch S1731 allows the user to select the guard configuration most suited for his measurement requirements. Resistor R1626 provides a known impedance of 1 M Ω between the GUARD and LOW inputs with the Guard switch open. Refer to the Operating Instructions in Section 2 for specifics concerning use of the GUARD input. The internal Guard is connected to the rear LO when using the rear interface inputs.

With the low (-27 V) applied to K1631-4, indicating that measurements should be taken from the rear interface connector, current to activate the relay flows through both R1613 and CR1621. Once activated, the current path through R1631 is opened and only the smaller current necessary to keep the relay activated flows in the relay via CR1621 and R1615.

ATTENUATOR 1

The input signal to be measured passes through a resistive attenuator network that prescales the analog signal to fall within the input circuitry's dynamic range. Attenuation factors of 1 and 100 are controlled by closing contacts of relays K1527, K1425, and K1525 as shown in Fig. 4-1 and Tables 10-2 and 10-5 in the pull out pages.

OVERVOLTAGE PROTECTION AND FUNCTION SWITCHING 1

All measurement modes of the DM 5010 require that some type of conditioning be performed on the input signal before an A/D conversion is performed. In each case, the input conditions are converted to a representative dc voltage level by the appropriate conditioning circuitry and are then applied to the DCV Signal Conditioner where some range-dependent gain factor is applied to the signal. This resultant prescaled signal is the basis for all A/D conversions and, along with the various mode, attenuation, and

gain factors set by the microprocessor, represents the input conditions.

This stage selects the appropriate conditioning circuit output and routes it to the DCV Signal Conditioner input. It also provides overvoltage protection should these signals exceed the specified input range.

A simplified schematic of the Overvoltage Protection and Function Switching stage appears in Fig. 4-2. Each of the FET switches connects either an individual function or the high quality ground reference to the DCV Signal Conditioner when closed. Refer to Tables 10-2 and 10-5 in the pull out pages for mode-dependent function and range switch settings.

Transistors Q1327 and Q1323 connected as diodes prevent the input voltage applied to FET switch Q1319 from exceeding $\approx +23$ volts and -23 volts, respectively. Similarly, transistors Q1321 and Q1322 prevent the output voltage of the Ohms Converter from exceeding the same voltages.

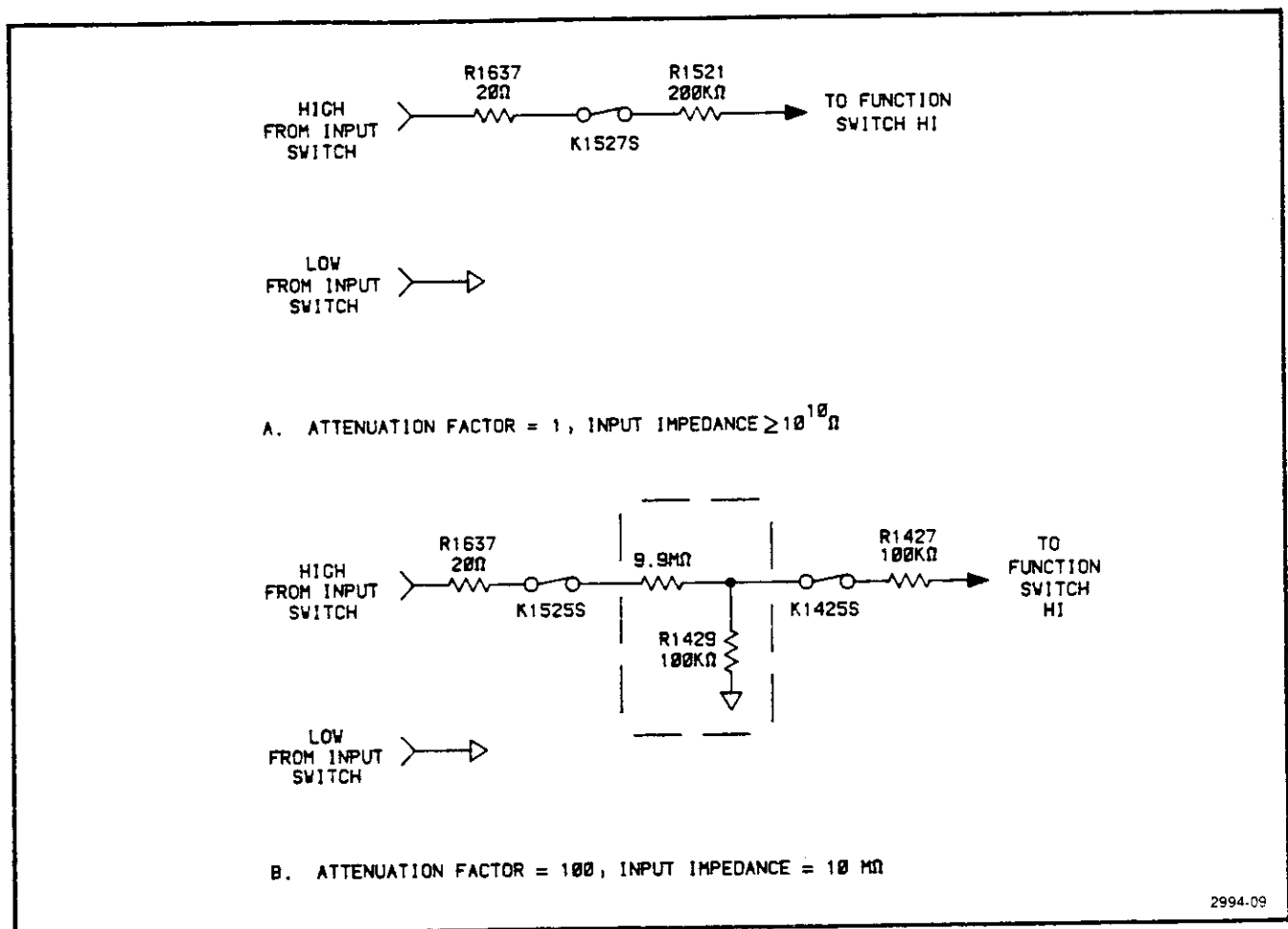

Fig. 4-1. Attenuator.

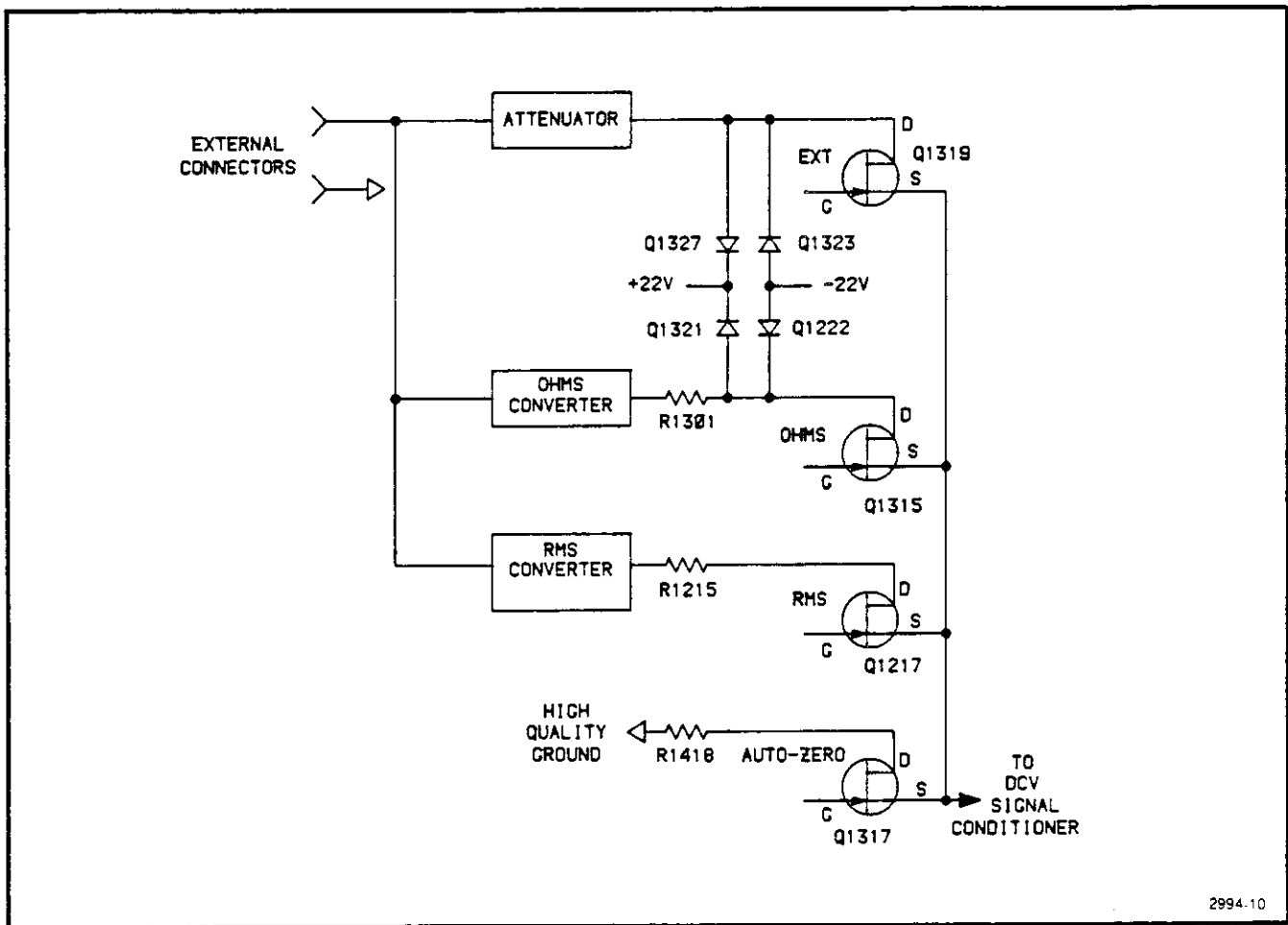

Fig. 4-2. Simplified overvoltage protection and function switching.

DCV SIGNAL CONDITIONER 1

The DCV Signal Conditioner provides range-dependent gain for the various dc mode-dependent signals applied to it. Figure 4-3 shows a simplified diagram of the buffer amplifier. Table 4-1 shows the states of the buffer amplifier.

Table 4-1
DCV SIGNAL CONDITIONER GAIN SETTINGS

| FET Switch | Gain of the Buffer Amplifier | | |
|---------------|------------------------------|-----|-----|
| | 10 | 1 | 0.1 |
| Q1105 | ON | OFF | OFF |
| Q1106 | OFF | OFF | ON |
| Q1112 | OFF | ON | ON |
| Q1114 | ON | ON | OFF |

The Function Switch directs the mode-dependent dc level to the noninverting input of U1210, the buffer amplifier. The

gain of the buffer amplifier is set depending on which of the FET switches are turned on by a high at their gates. Feedback to the inverting input of the operational amplifier is through either Q1112 or Q1105 while forward attenuation of the signal to the A/D converter is determined by Q1114 for Q1106. Diodes CR1221 and CR1223 prevent overdriving the buffer amplifier.

To ensure linear response of the buffer amplifier over its input range, a bootstrap buffer is used to make the buffer amplifier supply voltages track its input. This has the effect of making U1210 operate at the middle of its range, avoiding the linearity problems encountered when the output approaches one of the supply voltages. By making the gate bias of the various FET switches also track the input voltage, proper bias is maintained and current leakage through the FETs (and thus the associated error) is minimized. A simplified schematic of the bootstrap buffer is shown in Fig. 4-4.

The input to the bootstrap buffer, pin 3 of U1110, is connected to the inverting input of U1210 and is therefore at the

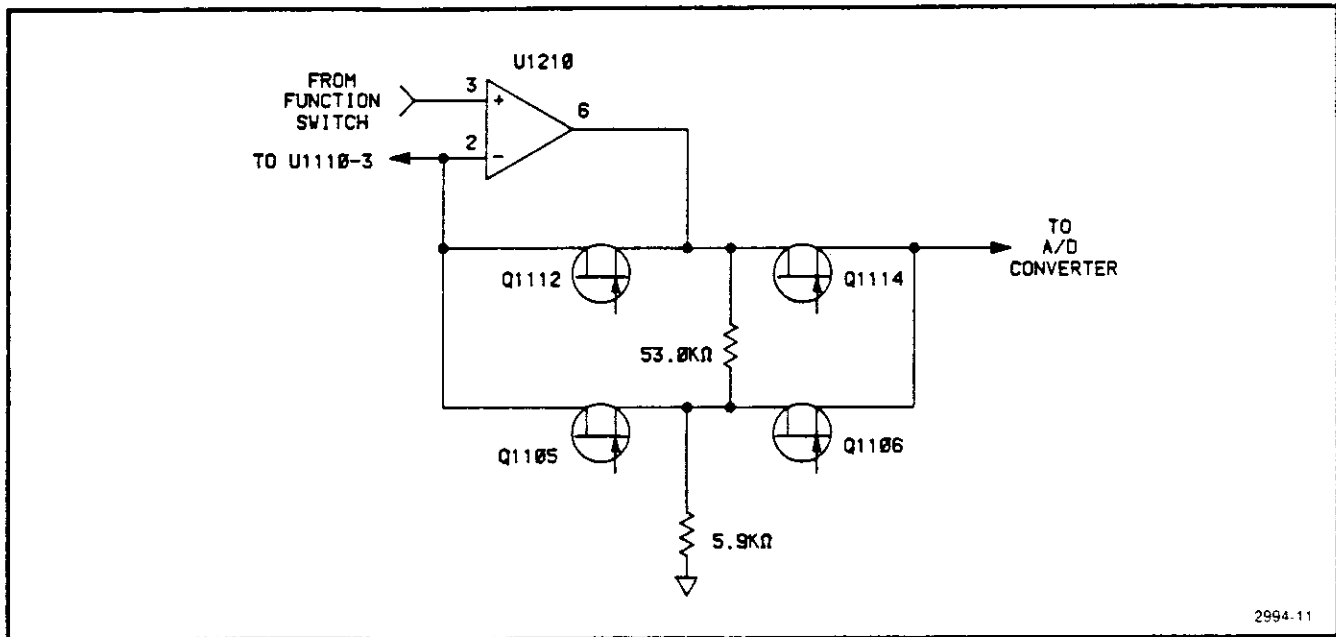

Fig. 4-3. Simplified DCV signal conditioner buffer amplifier.

same voltage as the input of the buffer amplifier. Operational amplifier U1110 and transistors Q1017 and Q1021 form a unity gain, noninverting amplifier that tracks the input of the DCV Signal Conditioner. Hence, the bases of Q1101 and Q1111 follow the input signal (plus and minus 6.2 volts, respectively, as determined by VR1011 and VR1015). The emitters of Q1101 and Q1111 (and thus U1210's supplies) remain +5.5 volts and -5.5 volts away from the input voltage, respectively. Diodes CR1111 and CR1113 allow the operational amplifiers supply pins to follow the buffer amplifier input under transient conditions where Q1101 or Q1111 might become reverse biased.

As an example, let the input to the buffer amplifier start at zero volts. The input to U1110 at pin 3 and, thus, the buffered output at pin 2 must also be at zero volts. Zener diodes VR1001 and VR1013 along with resistor R1011 bias transistors Q1001 and Q1015 on, allowing current to flow in Zener diodes VR1011 and VR1015. This sets the bases of Q1101 and Q1111 at +6.2 volts and -6.2 volts, respectively. Their emitters, and U1210's supplies, are at +5.5 volts and -5.5 volts, respectively.

If the input to the buffer amplifier goes to +15 volts, the input to the bootstrap buffer also goes to +15 volts. The output at the emitters of Q1017 and Q1021 goes positive until the inverting input of U1110 also reaches +15 volts. The bases of Q1101 and Q1111 go to +21.2 volts and +8.8 volts, respectively. The supply voltages at their emitters go to +20.5 volts and +9.5 volts, respectively. The supply voltages are plus and minus 5.5 volts from the input voltage of the buffer amplifier, so it is operating in the middle of its range.

CHARGE-BALANCING CONVERTER 1

The Charge-Balancing Converter is the analog portion of the A/D Converter and, along with the Control Logic, Timing Logic, opto-isolators, and Data stages, changes the analog-dc voltage from the input-conditioning circuits to a digital representation. It derives its name from the fact that, during one conversion cycle, the total current added to and subtracted from the input summing node equals zero. Input buffer U1120 and the charge-balancing IC U1230, along with their associated components, comprise the Charge-Balancing Converter stage. Figure 4-5 shows a diagram of the stage with details of the converter IC added for clarity. The Block Diagram illustrates the major functional interconnections used in this description. The Block Diagram description explains some of the general charge-balancing concepts that should be understood before proceeding with this description.

The A/D conversion process is based upon two main time-dependent periods called Auto-Zero and Measurement. The Auto-Zero period involves setting a zero-reference voltage for the Charge-Balancing Converter. The actual conversion on the selected input is performed during the Measurement period. Both are synchronized to the microprocessor clock by the Timing Logic. Figure 4-6 illustrates some of the critical timing for each period of the conversion process.

Both of the above conversion phases are based on what are known as measurement intervals. The Timing Logic divides the microprocessor 1 MHz clock down to a 250 kHz

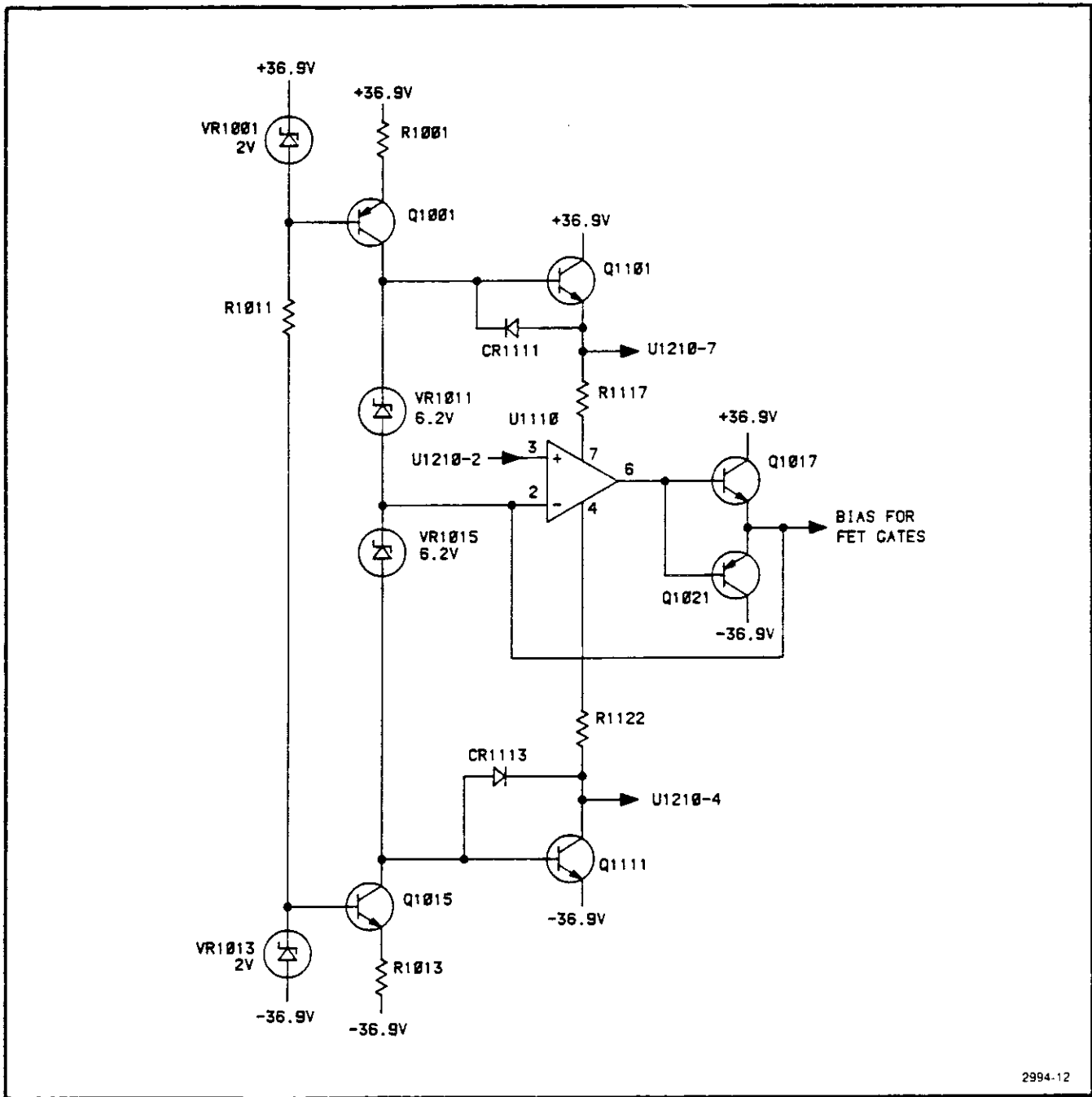

Fig. 4-4. Simplified DCV signal conditioner bootstrap buffer.

rate. Eighteen of these 250 kHz clock pulses in sequence comprise one measurement interval. Some special counters and decoding logic define the beginning, middle, and end of each interval and initiate or terminate certain conversion functions as shown in Fig. 4-6.

Auto-Zero

Before a conversion is performed, an initial zero-reference voltage (≈ -2 V) must be set. The Function Switch, under direction of the Function and Range Control circuitry, switches the input of the DCV Signal Conditioner buffer amplifier to the high quality ground to initiate the Auto-Zero period. The input signal, and the output of input buffer U1120, goes to zero volts.

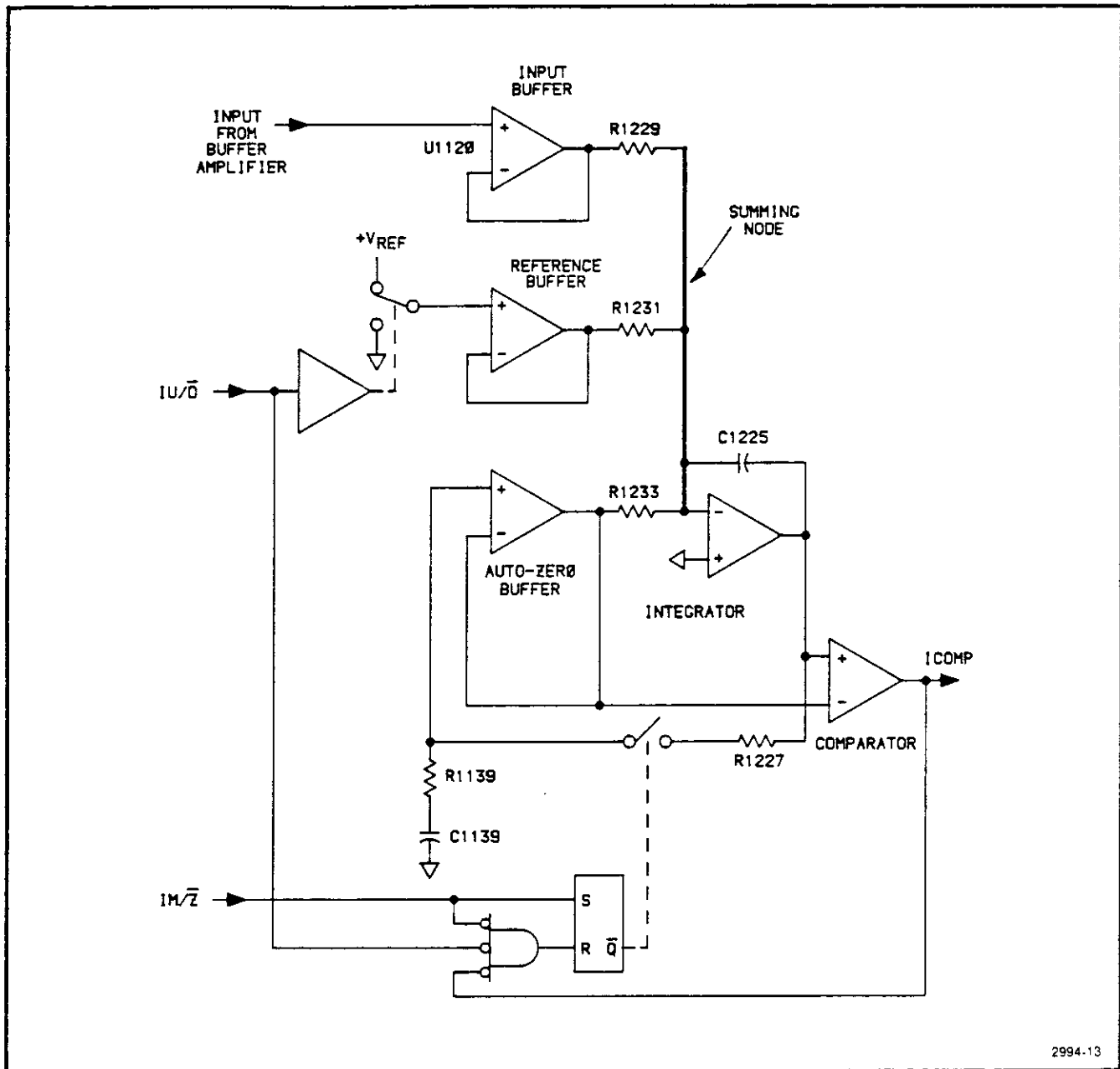

Fig. 4-5. Simplified charge-balancing converter.

Figure 4-7 illustrates the currents at the summing node when the zero-reference is being set. The node current from the Converter Input buffer, U1120, may be ignored since it is very small during the Auto-Zero period.

As the Auto-Zero period begins, a counter in the Timing Logic is set to zero. The Reference Buffer input is then toggled by T0 and T8 with a 50% duty cycle between $+V_{ref}$ and ground, injecting an average current $I_{ref\ in}$ equal to $+V_{ref} / (2 \times R1231)$ into the summing node. The Integrator produces a voltage output to the Auto-Zero Buffer. The Auto-Zero Buffer sinks current, via R1233, of opposite po-

larity to the current injected by the Reference Buffer until the current removed from the node balances the current being injected. This is the equilibrium state, and the voltage waveform at the input of the Auto-Zero Buffer is that required to precisely track the injected current input. Resistors R1139, R1227, and capacitor C1139 at the Auto-Zero Buffer's input integrate the integrator output waveform over a preset number of measure intervals. The negative Auto-Zero Buffer output voltage across R1233 generates a current equal in magnitude but of opposite polarity to the average injected reference current. The averaged voltage at the input of the Auto-Zero Buffer is the zero-reference volt-

2994-13

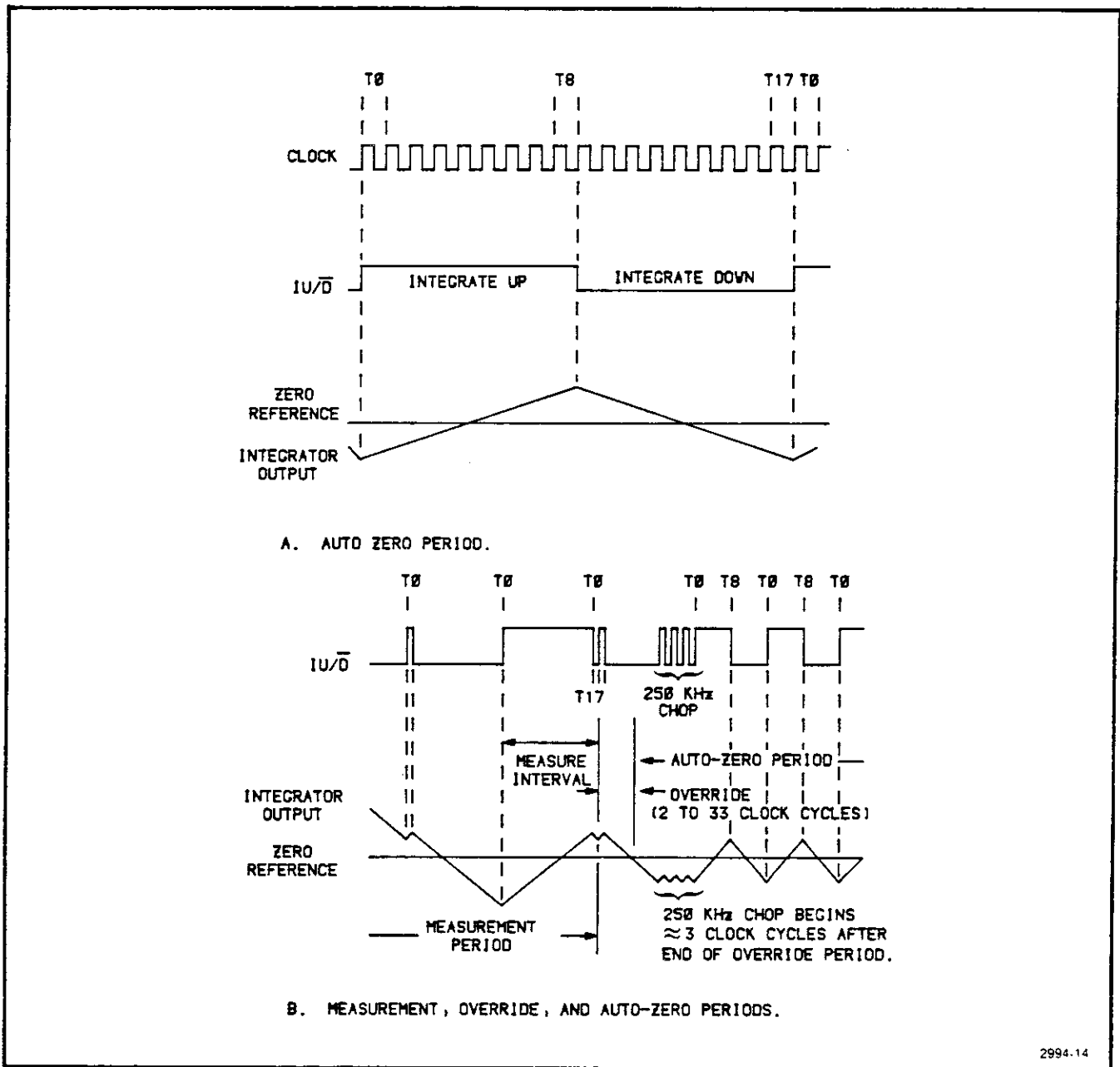

Fig. 4-6. U/D control for the measurement, override, and auto-zero periods.

age. It is stored on C1139 by opening the switch associated with R1227 at the end of the Auto-Zero period. The Integrator output is disconnected from the Auto-Zero Buffer and the zero-reference voltage is buffered to the Comparator.

Measurement

The Measurement period, like the Auto-Zero period, is based on timing signals developed by the Timing Logic. After the Auto-Zero period is complete, the Measurement period begins with T_0 of the next measurement interval. As shown in Figs. 4-6 and 4-8, the Integrator's output always

charges positive during T_0 and negative during T_{17} . The charge direction for the entire T_1 - T_{16} period depends on the polarity of the Comparators output at the end of time T_0 .

As the measurement begins, the input current I_{in} is switched into the summing node along with the negative reference current $I_{ref out}$. After a short time, the comparators output ICOMP (isolated comparator) goes high, indicating that the Integrator output is more positive than the zero-reference voltage set during Auto-Zero. At the next T_0 , the control Logic sets the I U/D (isolated up-down) low to

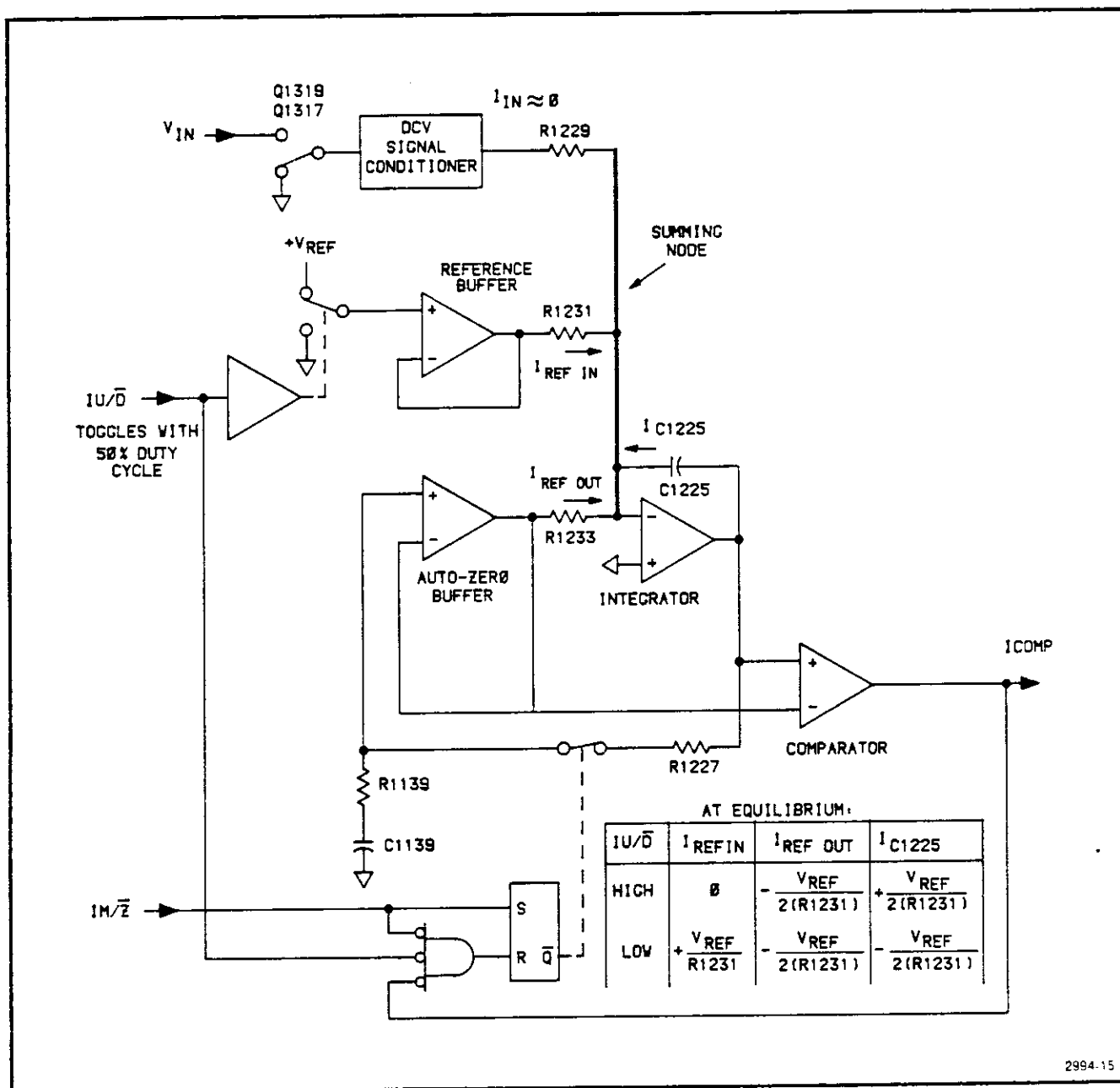

Fig. 4-7. Charge-balancing converter configuration during the auto-zero period.

change charge direction and rate. This is done by switching $I_{ref in}$ into the summing node. The Integrator output now charges negatively toward the zero-reference voltage for a complete number of 18-count measurement intervals (except for each T_0 as explained above). An up/down counter in the Data stage keeps track of the net time required by the $I_{net ref}$ to balance the effect of I_{in} on the integrator capacitor by adding or subtracting a net count of 16 counts for each measure interval to a running total, dependent on the Comparators output state.

After the Measurement Period is completed, an "override" period is entered, in which the integrator is allowed to charge back to the zero-referenced voltage while accumulating counts in the Data counter. During this period the DCV Signal Conditioner input is connected to the high quality ground by $Q1317$. The $I_{net ref}$ balances the remaining charge on the integrator capacitor due to I_{in} .

Figure 4-8 illustrates the override period for measurement periods ending both above and below the zero-reference voltage. As shown in the figure, once the Comparator detects that the Integrator has charged below the zero-reference voltage, the Data counter is disabled (all counting is complete), and ≈ 3 clock cycles later the $I U/\bar{D}$ line is chopped at a 250 kHz rate (determined by the Control Logic). Chopping the Reference Buffer input between $+V_{ref}$ and ground at this high rate holds the integrators output close to the zero-reference voltage until the next T_0 . More information about the charge balancing sequences may be found in the Control Logic description.

zero-reference voltage. Transistors Q1511 and Q1512 comprise a level shifting buffer that shifts the $I M/\bar{Z}$ control line to a level compatible with the isolated logic levels.

MEASUREMENT ENABLE 2

Field effect transistor Q1514, along with R1514 and C1514, holds the $I M/\bar{Z}$ control line low for several hundred milliseconds during power-on, thus allowing the Auto-Zero Buffer Amplifier storage capacitor, C1139, to charge to the

ISOLATED REGULATORS 2 3

The Isolated Regulators stages on the RMS and ADC boards regulate the power from the Isolated Supply stage to the levels required by the Isolated Section of the instrument. Integrated circuits U1601, U1603, U1605, U1417, U1527, U1525, and U1515 are 3-terminal regulation devices with internal current limiting. Transistor Q1613, VR1514, and their associated components form a series-pass regulator referenced at -36.9 volts.

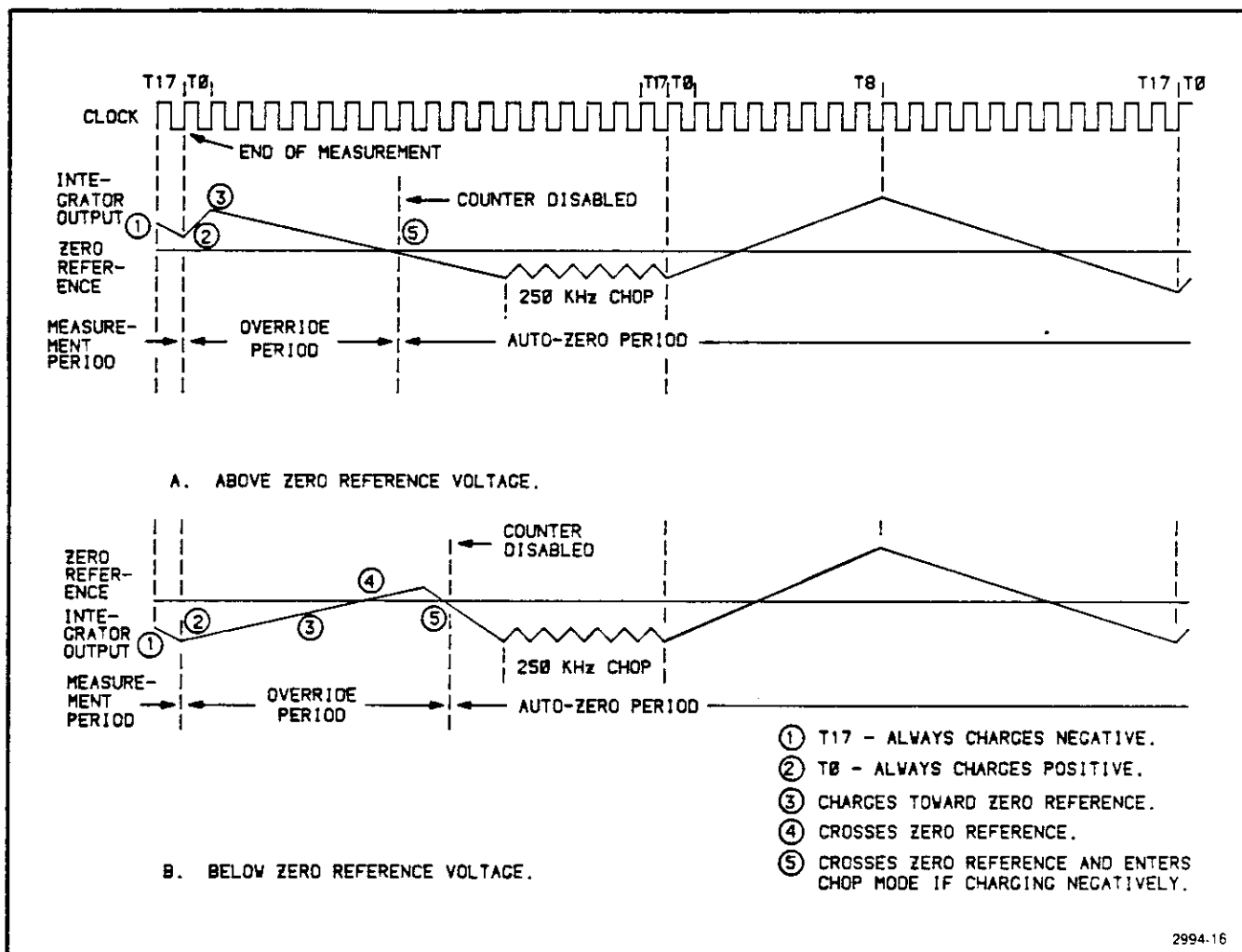

Fig. 4-8. Override and auto-zero timing for measurement period ending.

FUNCTION AND RANGE CONTROL 1 2

The purpose of the Function and Range Control circuitry is to convert a string of serial data from the Grounded Section (representing function and range information) into a parallel output configuration for activating transistor and relay switches. The combination of switches activated sets the measurement function and range.

Figure 4-9 is a simplified diagram of the Function and Range Control stages, showing how the two boards interact. Initially, all registers are cleared by clocking a series of 32 lows into U1430 from the opto-isolators using the IRD (Isolated Range Data) and IRC (Isolated Range Clock) lines, both of which are under direct microprocessor control. The low IRD levels applied to U1530 hold the STB (strobe) inputs of U1430 and U1330 high, allowing shifting to continue, no matter what serial data is being shifted out of U1300. Now, all registers are clear and are ready to be set with any

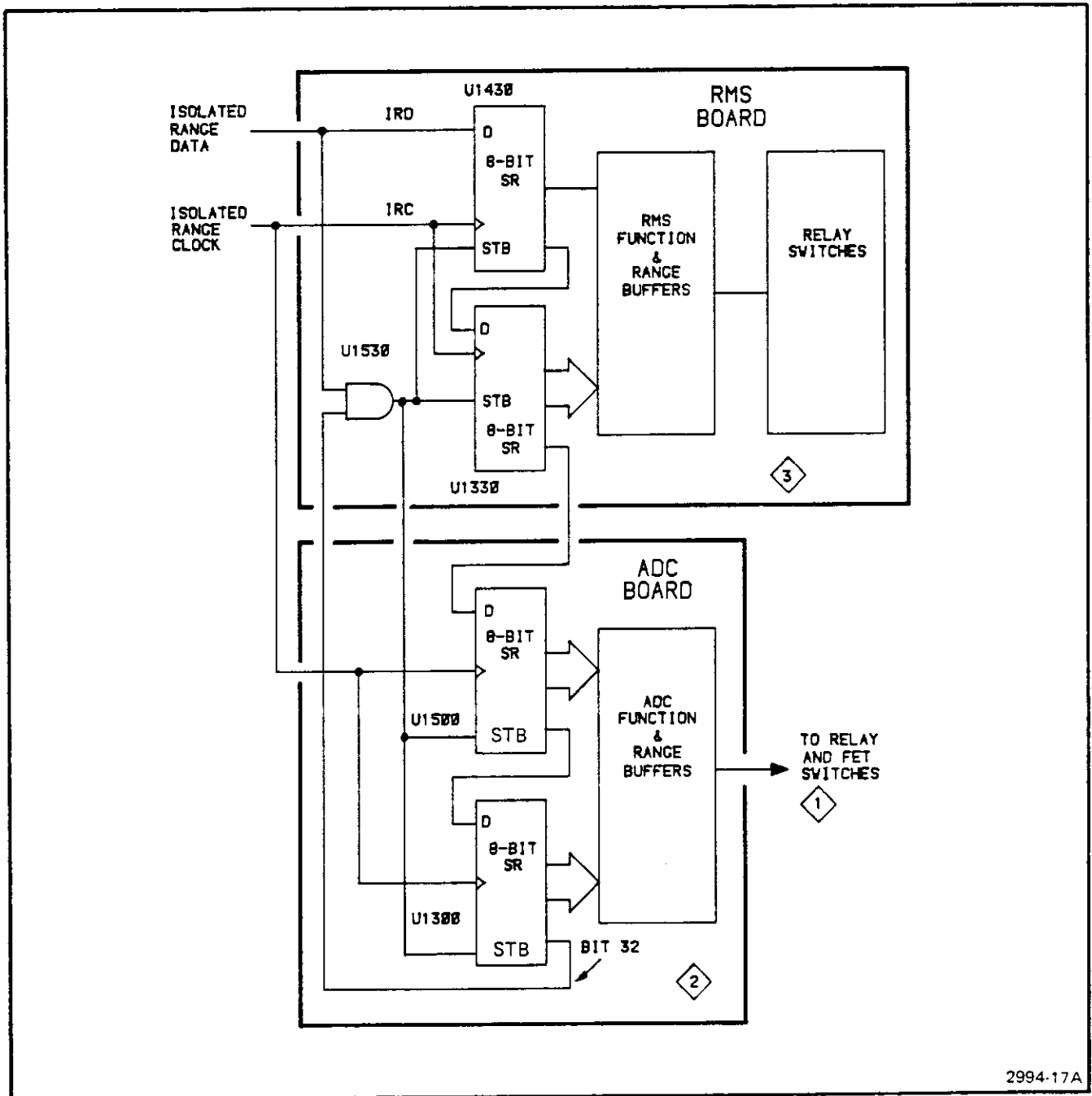

Fig. 4-9. Simplified function and range control circuitry.

new function and range information a new measurement may require.

To set the registers, a new string of serial data must be clocked into the registers. Since the registers have been previously reset, any data clocked into the registers from the IRD line also results in 32 consecutive lows being applied to U1530. This keeps the registers enabled while the new data is clocked into the registers. The first bit of function and range information is always a high signal bit, indicating the beginning of the new data. As the data string is shifted into the registers, this high is eventually clocked into the 32nd position. This, in itself, does nothing; but, another high is applied to the IRD line, signalling the end of the function range information. This causes U1530 to generate a strobe that latches the shifted data into the output registers of U1430, U1330, U1500, and U1300. To change the function and range settings to any new set of conditions, the reset-set sequence must be followed again.

With the exception of U1400, the remainder of the Function and Range Control circuitry consists of current buffering transistors. On the ADC board, U1400, U1500, and the shifted $1/M\bar{Z}$ signal generate the correct timing for the Function Switch FETs Q1319, Q1217, Q1315, and Q1317.

OHMS CONVERTER 3

The Ohms Converter stage supplies a known current that flows through a range-dependent reference resistor, out the front-panel input connectors, and through an unknown resistance. The voltage drop across the unknown resistance V_{ext} is measured, and then the drop across the unknown and reference resistance $V_{\Omega out}$ is measured. The ratio $V_{ext}/(V_T - V_{ext})$, multiplied by R_{ref} , is calculated by the microprocessor, and the value of the unknown resistance is determined. Figure 4-10 illustrates signal routing for each of the phases of an ohms measurement. Table 4-2 gives the range-dependent switching information.

Operational amplifier U1120 is configured as a voltage source. The noninverting input is referenced at 0.65 V by VR1123 and its associated components. Feedback from the output at the cathode of CR1225 is through the voltage divider R1229, R1321, and R1225. In this configuration, the output voltage is approximately 1.2 V. Depending on the measurement range, R1223 may be switched into the feedback voltage divider, increasing the stages output to approximately 10.2 V.

Transistor Q1021 and its associated components prevent the open circuit output voltage of the DCV Converter from exceeding +5 V.

Table 4-2
OHMS CONVERTER PARAMETERS

| RANGE | $V_{\Omega OUT}$ | IR_x | $VR_x AT FS$ | R_{ref} |
|-------|------------------|-------------|--------------|---------------|
| 200 | 10.2 V | 1 mA | 0.2 V | 10 k Ω |
| 2 k | 1.2 V | 0.1 mA | 0.2 V | 10 k Ω |
| 20 k | 10.2 V | 0.01 mA | 0.2 V | 1 M Ω |
| 200 k | 1.2 V | 1.0 μ A | 0.2 V | 1 M Ω |
| 2 M | 1.2 V | 0.1 μ A | 0.2 V | 10 M Ω |
| 20 M | 1.2 V | 40 nA | 0.8 V | 10 M Ω |

RMS CONVERTER 3

The RMS Converter stage consists of two selectable gain stages and a true rms-to-dc converter IC. Operational amplifier U1500 is configured as a feedback amplifier with a selectable gain (actually an attenuation) factor. The amplifier is referenced to the rms LOW input applied to its noninverting input. The HIGH input from the front-panel passes through relay contact K1633S to the amplifiers input when an rms measurement is to be taken. The ac signal passes through C1621 to a frequency compensation network and then to the operational amplifiers inverting input. If the dc component of the signal is also to be taken into account, relay K1621 is turned on and C1621 is bypassed. The amplifiers attenuation is set by the various feedback networks. With switches K1405S and K1503S open, the input amplifiers gain is unity. Closing switch K1503S reduces its gain by a factor of 10. Closing switch K1405S by itself results in an attenuation factor of 1000.

The output of U1500 is then applied to R1307, the input of a selectable gain amplifier, also referenced to rms LOW. With relay switch K1201S open, gain of the amplifier is 10 as determined by R1201 and R1307. Closing switch K1201S sets the gain factor to 1. Table 4-3 illustrates the various gain switch configurations for the RMS Converter. Also refer to Tables 10-2 and 10-5 in the pullout pages.

The output of the gain stage, U1200, is applied to a rms converter IC. This converter, referenced to rms LOW, computes the root-mean-square value of the applied ac or ac+dc input signal, and outputs at pin 8 a representative dc level to the Function Switch FET Q1217. Both operational amplifier gain stages have offset adjustments to establish their quiescent operating points.

GROUNDING POWER SUPPLIES 4

The Grounding Power Supplies regulate the +8 volts supply from the TM 5000-Series power module down to +5 volts for the bulk of the digital circuitry in the Grounded Section.

Table 4-3
RMS CONVERTER PARAMETERS

| Range | HI or V_n | K1405 | K1503 | K1201 | U1500 Gain | U1200 Gain | U1100-4 |
|--------|-------------|--------|--------|--------|------------|------------|---------|
| 200 mV | 200 mV | OPEN | OPEN | OPEN | 1 | 10 | 2 V |
| 2 V | 2 V | OPEN | OPEN | CLOSED | 1 | 1 | 2 V |
| 20 V | 20 V | OPEN | CLOSED | CLOSED | 0.1 | 1 | 2 V |
| 200 V | 200 V | CLOSED | OPEN | OPEN | 0.001 | 10 | 2 V |
| 700 V | 700 V | CLOSED | OPEN | CLOSED | 0.001 | 1 | 0.7 V |

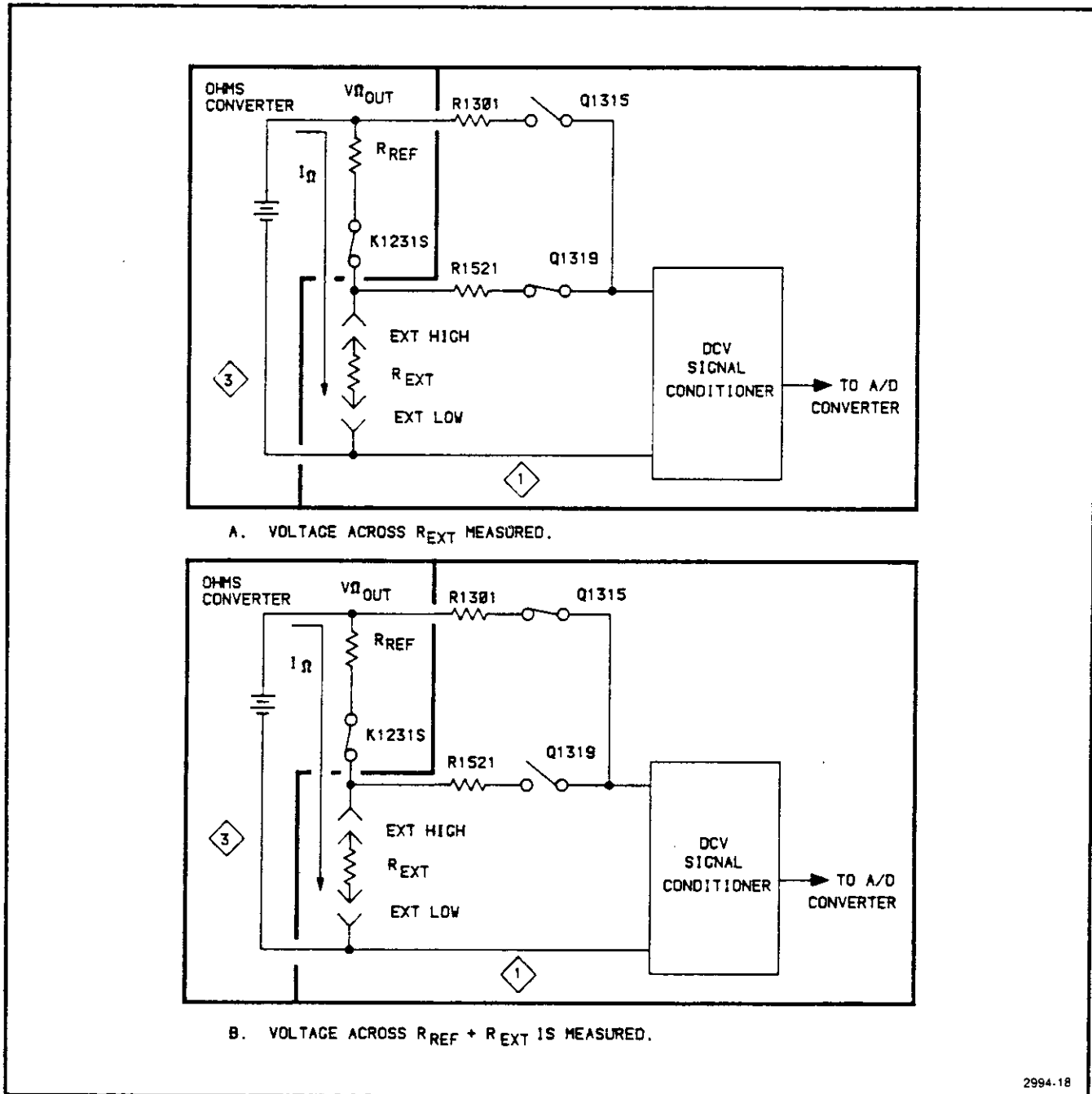

Fig. 4-10. Measurement switching during an Ohms conversion.

Theory of Operation—DM 5010

Initially, as the power module is turned on, the PWR MDL line is held low for a short time. This keeps Q1105 and Q1104 turned off, holding the output of U1000 high. This keeps Q1101 and the series-pass transistor in the power module turned off.

Then the PWR MDL line goes high and Q1105 is turned on. This forward biases Q1104, allowing current to flow through Zener diode VR1001. The inverting input of U1000 is now held at +5 volts and its output goes negative, turning on Q1101. As Q1101 comes on, base current begins to flow in the series-pass transistor to turn it on.

As its emitter is pulled toward the +8 volt supply, current flows in the voltage-sense network, R1005 and R1033. When the voltage at the noninverting output reaches +5 volts, bias current to Q1001, and thus the series-pass transistor, is reduced. The supply stabilizes at this point and the output closely approximates +5 volts.

Zener diode VR1216, resistor R1217, and the associated power-module transistor provide an overvoltage protection network on the +5 V supply line. If the +5 V line exceeds ≈ 5.7 V, the transistor becomes forward biased and begins to shunt excess current to ground. This protects the bulk of the circuitry in the Grounded Section of the instrument should a component in the +5 V regulator fail.

primary winding connected to the power module's +25 V supply, the ends of the primary coil are alternately switched to ground at an approximate 27.78 kHz rate. This rate is synchronized to the A/D conversion process and minimizes any converter error caused by power supply ripple in the Isolated Section.

Flip-flop U1325B and inverter U1520B convert the unsymmetrical 27.78 kHz timing signal from the Timing logic to a pair of symmetrical and complementary signals to drive the transformer switching amplifiers. Figure 4-11 illustrates the timing relationships of the symmetry conversion.

The complementary squarewaves at the outputs of U1325B drive two identical current-switching amplifiers to control current flow in isolation transformer T1311. A pair of transistors in each amplifier are driven in a push-pull configuration to provide the large base currents and fast switching times required for efficient power transfer.

ISOLATED POWER SUPPLIES 4

The Isolated Supplies provide rectification and initial filtering for the power transferred from the power module to the Isolated Section via the Isolation transformer. Capacitor network C1301, C1401, C1403, and C1404 provide noise cancellation by summing out-of-phase currents until cancellation occurs.

TRANSFORMER DRIVE 4

The Transformer Drive circuitry switches current from the TM 5000-Series power module through transformer T1311 to drive the Isolated Supplies. With the center tap of the

CONTROL LOGIC 5

The Control Logic generates the control signals that control the A/D conversion process. It uses time-related signals

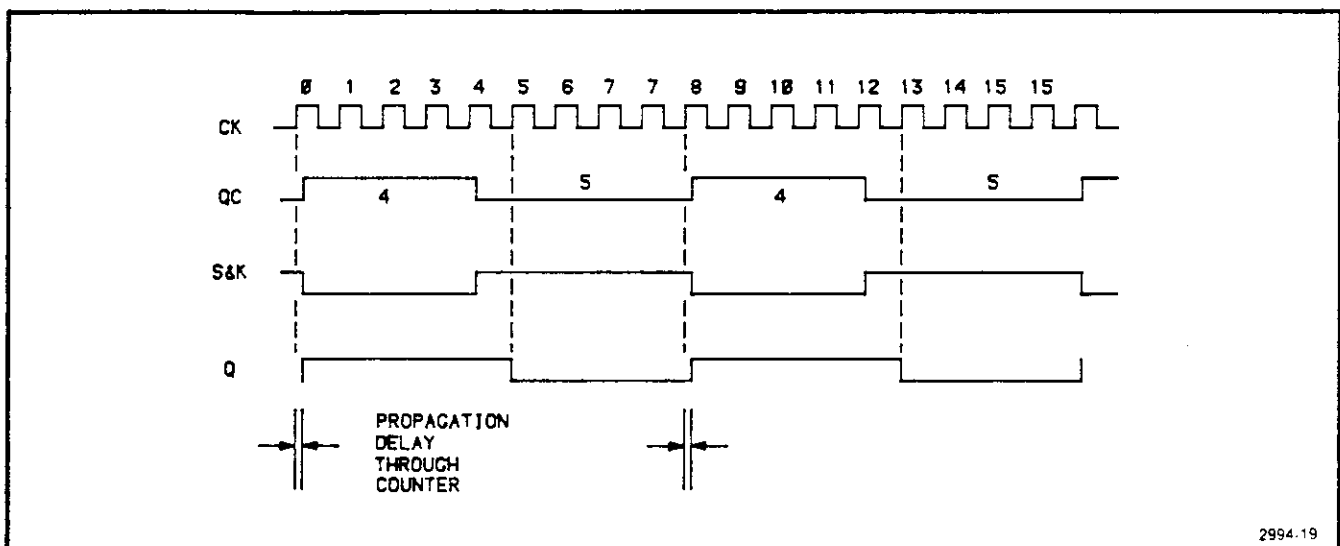

Fig. 4-11. Transformer drive timing.

generated by the Timing Logic and the comparison data from the Charge-Balancing Converter to automatically sequence through the complex and varied measurement functions.

To initiate a measurement, the microprocessor generates a low $\overline{\text{TRIG}}$ via the Address Decode circuitry. This TRIG pulse is latched by U1530A and U1530B and sets the IN PROGRESS line high, telling the microprocessor that the conversion is in progress and valid data is not available. The J input of U1425A is set high via U1435C and, at the beginning of the next measurement interval (falling edge of T17), the M/ $\overline{\text{Z}}$ (measure-zero) level is set high. This signal is transmitted to the Charge-Balancing Converter via the opto-isolators and initiates its measurement sequence. The $\overline{\text{Q}}$ output of U1425A sets the J input of U1230A high via U1530C and, on the next 250 kHz clock (T0), the UP clock and DOWN clock logic, U1135A and U1135C, is enabled.

The up/down counter now accumulates clock pulses as described in the Charge-Balancing Converter description until the Timing Logic generates an EOC (end of count) pulse to U1435A, signalling that the proper number of measurement intervals have been completed. This applies a high to the J input of the override flip-flop U1330A and the next clock pulse (T0) sets its $\overline{\text{Q}}$ output low. This low is applied to U1425B and keeps any subsequent trigger from passing through U1435C that might re-initiate the measurement sequence before it is completed.

The measure-zero flip-flop is reset on the next clock (the falling edge of T17 coincides with rising T1). The low input to U1530C from U1330A keeps the UP counter and DOWN counter logic enabled during the override period by keeping U1230A's J input held high. This enables the data counter to keep counting while the Charge-Balancing Converters integrator makes its final charge back to the zero-reference voltage as explained in the Charge-Balancing Converter description. Integrated circuits U1430C and U1435B reset the override flip-flop when integrating down (pin 9 of U1330B high) and the zero-reference voltage is crossed (COMP goes low).

The next clock pulse after the override flip-flop is reset disables the UP clock and DOWN clock logic by clocking U1230A's Q output low. This clocks chop flip-flop U1230B and the 250 kHz clock is enabled through U1435D. The low Q output of the chop flip-flop holds U1330B in its set state, and the cathode of opto-isolator U1710's transmitter LED is held low. This results in the 250 kHz chopping of the I U/ $\overline{\text{D}}$ line, keeping the Charge-Balancing Converters integrator output very close to the zero-reference voltage as explained in that description.

At the end of the next T17, $\overline{\text{T17}}$ sets U1230B to disable the chopping clock and allow U1330B to distribute clocks in its usual manner.

The clock enable provided by U1230A to U1135A and U1135C allows clock pulses to be passed to the data counter whenever the A/D converter is in its measurement or override modes. During this time, generation of either an UP clock or a DOWN clock is controlled by U1330B. T17, applied to U1330B's K input, always sets $\overline{\text{Q}}$ high, enabling UP clocks to the data counter on the next clock (T0).

Any of four gates OR'd together by U1335A have the ability to generate a DOWN clock enable, depending on the converters operating mode.

When generating the squarewave I U/ $\overline{\text{D}}$ required for Auto-Zero, T17 initiates a series of UP clocks, starting at T0 as mentioned above. Integrated circuit U1430A detects T8 when operating in the Auto-Zero mode and applies a high to U1330B's J input via U1335A. The next clock to U1330B (T9) initiates a series of 9 DOWN clocks. At T17, the cycle repeats itself.

When in the measurement mode, clock pulses between T1 and T16 may be either high or low, as described in the Charge-Balancing Converter description, but all must be the same. This determination is made at the end of T0 by U1335B. When measuring, the M/ $\overline{\text{Z}}$ level at pin 12 is high. Pin 13 is high during all of T0, the time when the decision about T1-T16 must be made. If the COMP (comparator output) level from the A/D converter is high at the end of T0 (indicating the integrators output is above the zero-reference voltage), a high is applied to the J input of U1330B via U1335B and U1335A. The next clock pulse (T1) sets U1330's Q output high and T1-T17 are DOWN clocks to the Data counter. If the COMP level were low at clock T1, all of the T1-T16 clocks would be UP clocks, since U1330B did not change.

In either case, T17 is always a DOWN clock as determined by U1430D. During T16 when in the measurement mode, a high is applied to pin 11 of U1330B via U1430D and U1335A. The next clock (T17) clocks a high to U1330B's Q output and produces a DOWN clock whether T1-T16 are DOWN clocks or not.

During the override period, clocks must be enabled to the Data counter, but only until the integrators output charges beyond the zero-reference voltage, going negative (COMP goes high to low). Integrated circuit U1430B detects when this occurs and, along with U1430C, U1435B, and U1330A, completely disables all clocks to the data counter while the remainder of the override period chops the I U/ $\overline{\text{D}}$ line.

Theory of Operation—DM 5010

At the end of the measurement and override periods, U1420C generates a $\overline{\text{CLR2}}$ pulse to reset trigger latch U1530A and U1530B. This sets the IN PROGRESS line low and tells the microprocessor that the A/D conversion is over and valid data is available. It also sets the Data stage to address the first bit (LSB) of data for transfer onto the Data Bus.

During the time the data is read, the Control Logic automatically initiates an Auto-Zero period after the end of override. Then U1420A clears the interval timer and Auto-Zero intervals are counted. At the end of the Auto-Zero period, the Timing Logic generates an EDAZ (End Of Auto-Zero) to U1425B. This enables further measurement sequences to be initiated by the microprocessor TRIG line from the Address Decode block.

As the next measurement cycle is initiated, U1420D resets the contents of the data counter to zero, and U1420A resets the Timing Logic's interval counter so measurement intervals may be counted. The cycle repeats itself as often as initiated by the microprocessor.

OPTO-ISOLATORS 5

The opto-isolators couple digital control and data signals between the Grounded and Isolated Sections of the

DM 5010 while maintaining electrical isolation between the two. Each isolator consists of a light-emitting diode that is turned either on or off by the drive circuitry, and a photo-detector diode and buffer to sense and buffer the transmitted signal. Each isolator buffer has an open collector output and pullup resistors are required. Integrated circuits U1605 and U1613 are three-terminal regulators used to provide the correct output levels for the various isolators. Transistor Q1615 and R1615 set the ON current for U1510's LED.

TIMING LOGIC 6

The Timing Logic stage generates the time-dependent signals for the A/D conversion process as well as the timing signals to sync the Transformer Drive circuitry to the conversion process (to minimize error caused by power supply noise). The stage is essentially a series of counters and some decoding logic that determines when certain phases of the mode-dependent conversion process should be initiated or have been completed.

Flip-flops U1535A and U1535B comprise a $\div 4$ counter that divides the 1 MHz microprocessor clock down to a 250 kHz rate. From there, the 250 kHz clock is divided by 18 to generate the intervals for the charge-balancing conversion by U1730, U1630A, U1630B, U1320B, U1635B, U1635C, and U1530B. Refer to the timing diagram in Fig. 4-12 for the following description.

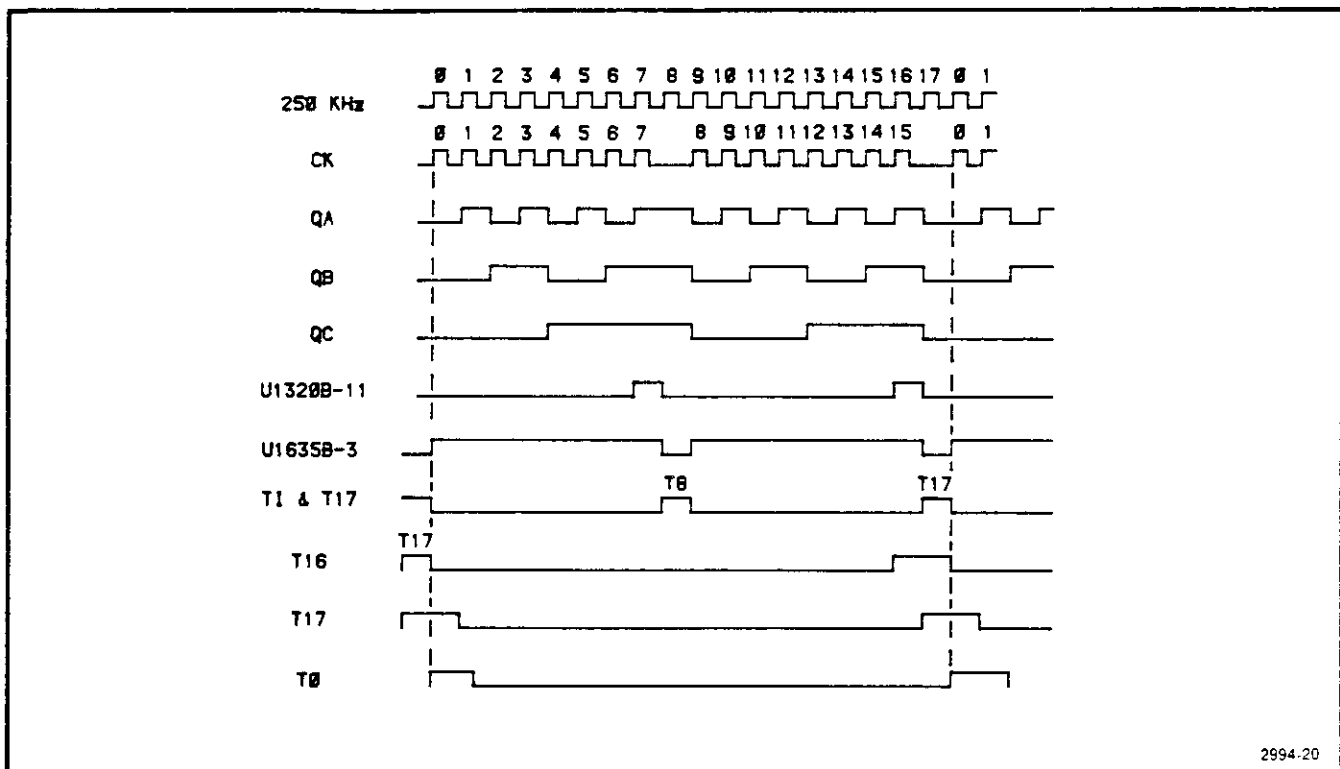

Fig. 4-12. Timing of the divide by eighteen counter.

Initially, pin 3 of U1635B is high. As the 250 kHz clock is applied to U1730, counting begins. When U1730's binary outputs equal 7, a high is applied to the J input of U1320B via U1635C and U1530B. The falling edge of the 250 kHz clock (actually rising \bar{Q}) clocks the high to the Q output (T8) of the U1320B. The complementary low at its \bar{Q} output is applied to U1635B and disables the next clock to U1730. The J input of U1320B is high (U1730's count is still 7) and the K input is latched high by the Q output. The T8 interval line at the Q output of U1320B is toggled low by the next 250 kHz clock, re-enabling the clock to U1730 (\bar{Q} goes high). Once again U1730 counts normally until its binary output equals 15. On the falling edge of the 250 kHz clock, a high is clocked to the Q output of U1320B and the complementary low at its \bar{Q} output disables the next clock through U1635B.

Line T16 at pin 15 of U1730 goes high when its binary output equals 15 (actually count 16 because one clock is skipped). The next clock (17th) sets the T17 output at pin 5 of U1630A high and, on its falling edge, clocks to U1730 are re-enabled. The rising edge of the next 250 kHz clock sets the binary outputs of U1730 back to zero and initiates the T0 pulse at the terminal of flip-flop U1630B. Although generation of a T0 pulse is actually dependent on the presence of a T17 pulse, the instrument considers T17 to be the last pulse of the sequence and T0 to be the beginning of the next sequence.

Integrated circuit U1525 is a negative-edge-triggered binary counter that counts the number of 18-count charge-balancing intervals completed. As U1525 requires a negative clock, $\bar{T17}$ is applied to its clock input to signal the end of an 18-count interval.

The NAND gates connected to the binary outputs of U1525 generate two time-dependent control signals required by the Control Logic to perform an A/D conversion. During normal 4 1/2 digit operation, U1520C detects when 1536 measure intervals have occurred during the Auto-Zero period and causes a high EOAZ (End Of Auto-Zero) at pin 3 of U1520A, signalling that the Auto-Zero process should stop. At this time, the zero-reference voltage in the charge-balancing converter stage has been set. The counter is reset by CLR1 and the actual A/D measurement begins.

A measurement requiring 4 1/2 digit accuracy requires that the integrator integrate over 12 or 10 periods of the power line frequency for 60 or 50 Hz operation, respectively. Referring to Fig. 4-13, it can be seen that any noise at the instruments input affects the charge and discharge rates at the A/D converters summing node (and thus the time at which the node voltage crosses the zero-reference voltage).

In the DM 5010's charge-balancing A/D conversion, the time (number of counts) that the integrators output voltage is above the zero-reference voltage is subtracted from the time below the zero-reference voltage, and is representative of the input voltage. Though the magnitude of the ripple and the charge rates are extremely exaggerated in Fig. 4-13, a principle may be demonstrated.

If, for example, a measurement is taken over time interval A, the noise (at power line frequency) added to the summing node of the "antenna effect" of the test leads, results in a conversion more positive than the actual signal being measured. Similarly, a measurement taken over time interval B results in a conversion more negative than the actual signal.

By making the A/D conversion over a complete number of power-line cycles (A + B), these measurement errors cancel and the actual signal is accurately resolved. Since the DM 5010 will be used in environments where either 50 Hz or 60 Hz power is in use, the chosen time frame results in "complete-cycle" measurements for either line frequency.

For normal 4 1/2 digit measurements, U1620 detects when 2778 measurement intervals have occurred. This is equivalent to 200.02 ms of time or, in terms of "complete cycles", 12 cycles at 60 Hz or 10 cycles at 50 Hz. After the instrument measures for 200.02 ms, U1620 applies a low at U1635A, generating an EOC (End Of Count) pulse at its output. This EOC signals the Control Logic stage that the Measure Period of the measurement is over.

The DM 5010 also has the capability to perform 3 1/2 digit measurements at a faster rate. If the microprocessor determines that a 3 1/2 digit measurement should be initiated, it sets the 3 1/2 line high. This enables U1520B to generate the EOAZ pulse after 256 measure intervals have occurred during Auto-Zero. Integrated circuit U1525 is reset and begins to count measurement intervals for a 3 1/2 digit conversion.

Once again, because of the power-line noise picked up by the measurement leads, the A/D conversion must be performed over a number of complete power-line cycles. Adequate resolution for a 3 1/2 digit measurement may be obtained by performing the A/D conversion over just one power-line cycle at either 50 Hz or 60 Hz. Both U1625 and U1720 are enabled by the high 3 1/2 line and, if operating from a 60 Hz power line, the 50/60 mode-select-enable to U1720 is also high (this is set by an internal jumper to match the power-line frequency).

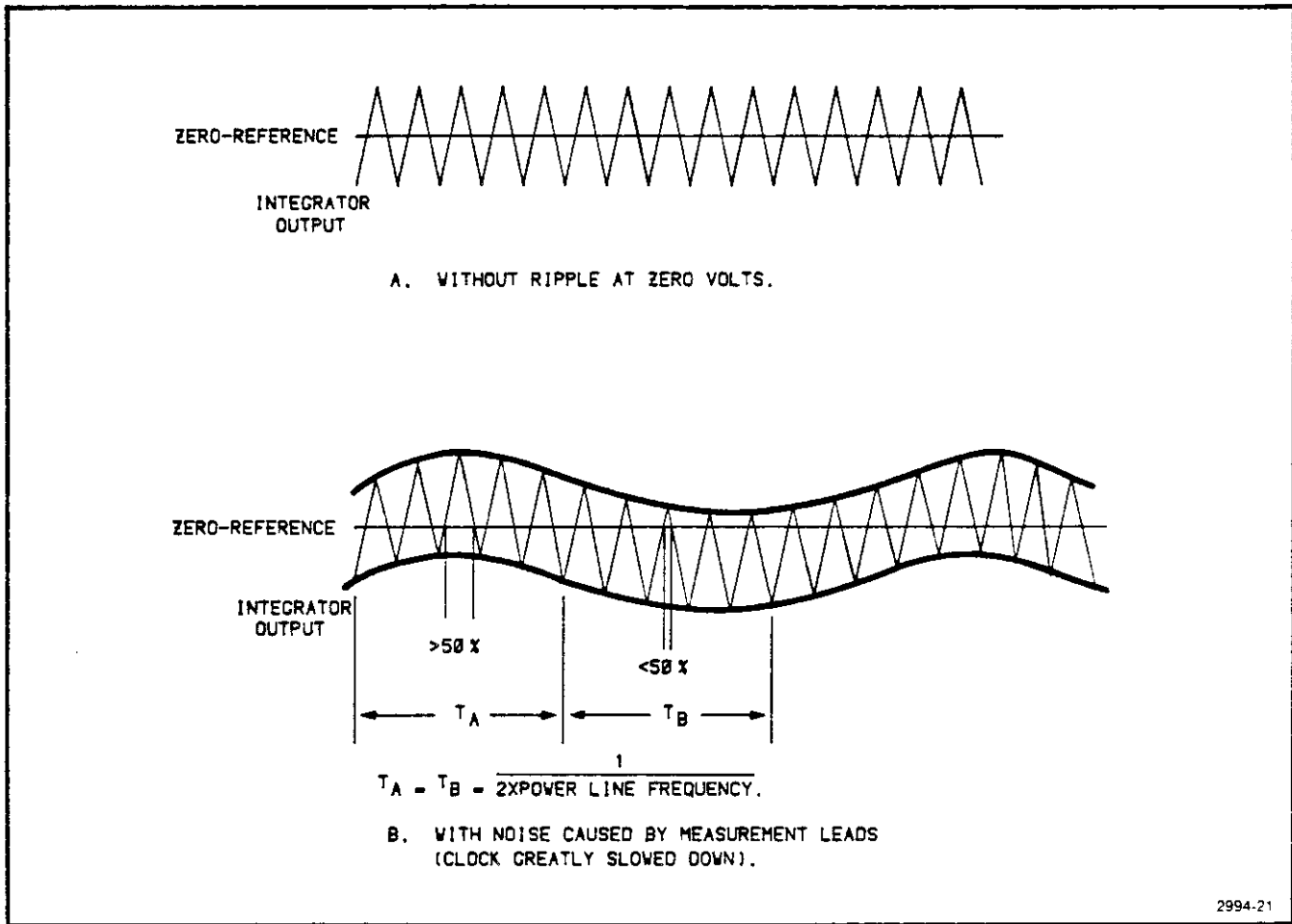

Fig. 4-13. Influence of power line frequency on A/D conversion.

When operating in a 60 Hz environment, U1720 detects when 231 measurement intervals have occurred. This is equivalent to 16.63 ms or one complete cycle at 60 Hz. At this time, U1720 causes an EOC to be generated at the output of U1635A, stopping the A/D conversion.

When operating in a 50 Hz environment, the 50/60 line to U1720 should be set low. This disables U1720 and U1525 counts up to 278 before the EOC is generated by U1625 and U1635A. This equates to 20.02 ms or one complete cycle at 50 Hz. As can be seen, in all cases the A/D conversion takes place over a complete number of power-line cycles, minimizing conversion errors caused by noise.

DATA 6

As described earlier, the result of a charge-balancing A/D conversion is a sequence of pulses. The number of pulses generated during the conversion directly represents the conditions at the converters input. The Data stage counts these pulses and later transfers the accumulated results to the microprocessor data bus as required by the processor.

The counter circuitry consists of four 4-bit up-down counters cascaded together along with a discrete-gate flip-flop to form a 17-bit up-down counter. The counter is reset at the beginning of a measurement cycle and then counts either up or down, depending on the polarity of the Integrators output with respect to the Comparators zero-reference voltage. At the end of the measurement period, the number of clocks accumulated ($T_{below} - T_{above}$) by the 17-bit counter is representative of the input conditions to the A/D converter.

When the conversion is complete and the results are stored in the counter, the Control Logic signals that conversion data is available to the microprocessor. This data is transferred from the counter to the Data Bus one bit at a time, starting with the least significant bit.

At the time the processor is told that the data is available, U1235 and U1230 are cleared by the Control Logic pulsing the CLR line low. This sets the Q output of U1320 high to enable data to be passed through U1030A. Since the Q output of U1320A is low, the data path through U1030D is disabled and the resulting high at its output enables U1030B.

Counter U1235, set to binary zero by the $\overline{\text{CLR}}$ pulse at the end of the measurement period, selects the least significant bit of data (at the E_0 input of U1125) to be output to the data bus via U1030A, U1030B, and the Miscellaneous buffer (diagram 9). As the processor begins its reading sequence, it reads this bit of data, and then generates an $\overline{\text{ADVANCE}}$ pulse via the Address Decode circuitry (diagram 7) to increment the counter U1235. The next LSB of data (E_1) is now selected by U1125 and is applied to the data bus. The processor continues reading data and advancing counter U1235 in this fashion until all 16 bits of data selectable by U1125 have been read. The next $\overline{\text{ADVANCE}}$ pulse generated by the processor causes a ripple-carry at pin 15 of U1235, and U1320 changes state. U1030A is disabled and the 17th bit of conversion data stored in the discrete flip-flop (U1135C and U1030C) is passed on to the data bus via U1030D, U1030B and the Miscellaneous buffer.

MICROPROCESSOR

The Microprocessor is the control center for all instrument operations. Operating under firmware control, the various types of data in the System are moved about and manipulated by the microprocessor. By addressing (selecting) the various devices or memory locations in the proper sequence (firmware control) and by properly manipulating and transferring the data associated with these addresses, each portion of the instrument performs its correct function at the correct time.

The DM 5010, as do all microprocessor systems, requires a system clock. The 4 MHz crystal, Y1221, provides a stable and accurate timing element for the microprocessor's internal clock oscillator. All other critical timing signals in the instrument are derived from the internally-divided $\phi 2$ (1 MHz) clock.

The VMA (Valid Memory Access) and $\overline{\text{R/W}}$ (read/write) lines control the enabling of devices on the data bus as well as the flow of data on the bus. The $\overline{\text{IRQ}}$ line (interrupt request) is used in conjunction with GPIB data transfers, which are explained in the Handshake Process. The remaining processor control lines, with the exception of the $\overline{\text{RESET}}$, are not used. The function of the $\overline{\text{RESET}}$ line is explained in the following description.

POWER-ON LOGIC

The Power-On Logic holds the DM 5010 circuitry in a reset condition for a short time after power up, or when a

momentary power supply fault occurs. This ensures that the +5 V supply has settled and that all instrument functions begin from a known state.

As instrument power is turned on, the +5 V supply comes up from 0 V to +5 V over some finite time period. During most of this time, the inverting input of U1230B is more positive than the noninverting input, keeping the output, at pin 7 low, and thus the system reset ($\overline{\text{PON}}$ at pin 1 of U1230A) at ground potential. As the supply voltage reaches approximately +4.7 V, the noninverting input at pin 5 goes more positive than the input at pin 6. As this occurs, the output transistor of comparator U1230B (an open collector device) is turned off.

Capacitor C1223 now charges toward +5 V through R1227. As the voltage across C1223 charges beyond +2.75 V, the inputs to comparator U1230A change relative polarity and the system reset ($\overline{\text{PON}}$) level at output pin 1 goes high. As previously mentioned, the time delay incorporated in this circuitry ensures that the +5 V supply has had time to settle before any operation is attempted.

ADDRESS BUS BUFFER

The Address Buffer stage consists of U1235 and U1420A. This stage provides the increased current drive required to address the many devices on the Address Bus.

ADDRESS DECODE

The Address Decode circuitry may be thought of as an extension of the address bus. This stage looks at the six most-significant bits of the address bus along with two function-dependent signals produced by the microprocessor to generate many of the required enable and control signals for specific devices within the instrument.

A high VMA (Valid Memory Access) signal, as does its inverted counterpart (low BVMA), indicates that the information on the address bus is pointing to a valid memory location. When these signals are present, decoders U1510, U1520, and U1620 along with U1720A, U1720B, U1730A, and U1730B in the logic state, generate the enable and control signals as shown in Table 4-4. The memory map shown in Table 4-5 further illustrates address decoding. Those signals associated with U1620 are all synchronized to the microprocessor by the $\phi 2$ clock.

Table 4-4
ADDRESS DECODING

| Address Bit | | | | | | | Generated Output | Equivalent Addresses | Size |
|-------------|----|----|----|----|----|----|------------------|----------------------|------|
| $\phi 2$ | 10 | 11 | 12 | 13 | 14 | 15 | | | |
| X | X | X | L | L | H | H | EROMC | CXXX | 4k |
| X | X | X | H | L | H | H | EROMD | DXXX | 4k |
| X | X | X | L | H | H | H | EROME | EXXX | 4k |
| X | X | X | H | H | H | H | EROMF | FXXX | 4k |
| X | X | X | X | X | L | H | Not Decoded | 8000-BFFF | 16k |
| X | X | X | X | X | H | L | Not Decoded | 4000-7FFF | 16k |
| L | L | L | L | H | L | L | EGPIB | 2000-23FF | 1k |
| L | L | L | H | H | L | L | ADVANCE | 3000-33FF | 1k |
| L | L | H | L | H | L | L | Set RD low | 2800-2BFF | 1k |
| L | L | H | H | H | L | L | Set 3 1/2 | 3800-3BFF | 1k |
| L | H | L | L | H | L | L | SA STOP | 2400-27FF | 1k |
| L | H | L | H | H | L | L | Set 4 1/2 | 3400-37FF | 1k |
| L | H | H | L | H | L | L | Set RD high | 2C00-2FFF | 1k |
| L | H | H | H | H | L | L | TRIG | 3C00-3FFF | 1k |
| X | L | L | L | L | L | L | ERAM | 0000-03FF | 1k |
| X | L | L | H | L | L | L | NC | 1000-13FF | 1k |
| X | L | H | L | L | L | L | EMISC | 0800-0BFF | 1k |
| X | L | H | H | L | L | L | ECMOS | 1800-1BFF | 1k |
| X | H | L | L | L | L | L | ESW | 0400-07FF | 1k |
| X | H | L | H | L | L | L | NC | 1400-17FF | 1k |
| X | H | H | L | L | L | L | EFP | 0C00-0FFF | 1k |
| X | H | H | H | L | L | L | RC | 1C00-1FFF | 1k |

Table 4-5
ADDRESS DECODE MEMORY MAP

| Starting Hexadecimal Address | Signal or Enable | Size (Decimal) |
|------------------------------|-----------------------|----------------|
| 0000 | ERAM | 1k |
| 0400 | ESW | 1k |
| 0800 | EMISC | 1k |
| 0C00 | EFP | 1k |
| 1000 | 1000-17FF NOT USED | 2k |
| 1B00 | ECMOS | 1k |
| 1C00 | RC | 1k |
| 2000 | EGPIB | 1k |
| 2400 | SA STOP | 1k |
| 2800 | 1 RD | 1k |
| 2C00 | 0 RD | 1k |
| 3000 | ADVANCE | 1k |
| 3400 | 3 1/2 | 1k |
| 3800 | 4 1/2 | 1k |
| 3C00 | TRIG | 1k |
| 4000 | 4000-BFFF NOT USED | 32k |
| C000 | EPROMC | 4k |
| D000 | EPROMD | 4k |
| E000 | EPROME | 4k |
| F000 | EPROMF | 4k |

LOGIC

The Logic stage works in conjunction with the Address Decode circuitry to generate process control signals required by the A/D conversion circuitry.

The set-reset latches, U1720A and U1720B, allow the microprocessor to set signal levels simply by addressing the function via the Address Decode circuitry. Table 4-4 shows the block of addresses that the microprocessor uses to set or reset the RD (Range Data) or 3 1/2 (measurement resolution) signal lines.

DATA BUS BUFFER

The Data Bus Buffer, U1435, provides bidirectional buffering of instructions and data on the data bus. Depending on the instruction being executed, the microprocessor either outputs data onto the data bus or reads from the bus by controlling buffer direction via its R/W (read-write) control line.

NOP BUFFER

By making the microprocessor execute a continuous series of NOP (no-operation) instructions, much of the microprocessor kernel may be exercised and verified apart from devices that may be malfunctioning on the Data Bus. Moving P1425 to its NOP position tri-states (disables) the normal Data Bus Buffer U1435 and, in its place, enables the NOP Buffer U1430. This device inverts its hardwired inputs and forces a NOP instruction (00000001) into the processor with each clock to make the processor "do nothing". In reality, the microprocessor sequentially increments through its entire address field, exercising many devices connected to the address bus in a repeatable and predictable fashion. This allows for verification of the kernel and may be used as an aid in distinguishing data-related problems from hardware problems when troubleshooting.

ROM

The ROM contains the operational firmware for the DM 5010. Data is read from the ROM stage one byte at a time from any of 16k locations as addressed by the microprocessor. The Address Decode stage described earlier enables only one of the four ROM IC's when the ROM is to be read. The 12 LSBs of the buffered address bus select one of the possible 4k bytes stored in the enabled IC to be output to the Data Bus where it is read by the microprocessor.

RAM

The RAM stage, U1600 and U1505, consists of two 1k X 4-bit RAM ICs and a small amount of enable logic. When the Address Decode circuitry detects an address within the allotted RAM space, it sets the ERAM line connected to the RAM CS (Chip Select) inputs low. This enables data to be read from or written to RAM, depending on the level of the WE (Write Enable) pins.

The RAM outputs the data addressed by the buffered address bits BA0-BA9 when ERAM is low and WE is high. Data may be written to the addressed location only when

Theory of Operation—DM 5010

the RAM block is enabled by $\overline{\text{ERAM}}$ low and when the write enable WE is also low. The write-to-RAM may only occur on a Valid Memory Access (VMA) writing B $\overline{\text{R/W}}$ to the RAM after the Data Bus is known to be valid (B $\phi 2$) as determined by U1630A.

CMOS RAM

The CMOS RAM stage, U1220, contains the calibration constants for the DM 5010. These constants, along with various algorithms stored in the firmware ROM, are used by the microprocessor to calculate measurement results. These constants are stored, as described below, at the time of initial instrument adjustment. During normal instrument operation, the CMOS RAM looks like ROM to the microprocessor.

On power up, transistor Q1123 is turned on and the CMOS RAM may be enabled by a low $\overline{\text{ECMOS}}$ from the Address Decode stage.

During normal instrument operation, jumper P1132 is in the NORM position and data may only be read from the CMOS RAM when $\overline{\text{ECMOS}}$ is low; R/W is always high. During instrument adjustment, however, new calibration constants must be written into the CMOS RAM. Jumper P1132 is moved to its CAL position and the $\overline{\text{VW}}$ (Valid Write) signal enables writing to the CMOS RAM in much the same way as writing to the normal RAM.

To store calibration constants, a specified signal is applied to the DM 5010 input and an A/D conversion is performed. The processor is then told to store this data as a calibration constant when the user presses the front-panel ENTER key. This routine is repeated until all calibration constants have been stored. Jumper P1132 is then returned to its NORM position and, for all practical purposes, the CMOS RAM functions as a ROM.

When instrument power is turned off, transistor Q1123 is turned off and the CS (Chip Select) input of U1220 is pulled high through R1133 up to the battery supply voltage. This tri-states the busses of U1220 to minimize power drain from the Battery circuit.

BATTERY

A Battery circuit is employed in the DM 5010 to maintain the calibration contents of the CMOS RAM when the instrument is not connected to a line-power source via the power module. When not driving the data bus (as when the instrument is off), the CMOS RAM requires very little power and a

small battery will maintain the calibration constants for the extended periods between instrument use.

In normal operation with power applied, power for U1220 comes from the +8 V supply through R1135 and CR1133. Diode CR1235 holds the anode voltage of CR1133 at +5.6 V. This results in +5 V being applied to pin 16 of U1220, the positive supply input. This +5 V is also applied to R1131, charging battery BT1121 when the instrument is operating. With power removed, U1220 is disabled, as described earlier, and the current to maintain the contents of the CMOS RAM flows through R1131 from battery BT1121.

MISCELLANEOUS BUFFER

This stage buffers three of the one-wide status bits and the serial conversion data onto the data bus so the processor may read them when required.

The $\overline{\text{EMISC}}$ (Enable Miscellaneous) signal from the Address Decode circuitry turns on buffer U1420B. This enables the microprocessor to read the data on the four most-significant bits of the data bus and make decisions based on these status and data bits.

Three of the four bits buffered onto the bus comprise status-type information. These bits affect the way in which the microprocessor performs its various control functions.

Since the A/D conversion process operates in either 50 or 60 Hz environment, the microprocessor must know which environment it is operating in. The 50/60 Hz jumper, P1723, is set to match the line frequency of the power source. This status bit may be read from data bus bit 5 as the processor requires.

The microprocessor continually checks the output of the set/reset latch, U1720C, which is buffered onto the data bus. If the Extrigger jumper, P1721, is in the enable position, a signal applied to the rear interface $\overline{\text{EXTRIG}}$ connector pin may be used to initiate triggering. In normal front-panel operation, jumper P1721 is in its disable position and a low is buffered onto Data Bus bit 4 when status information is read. With the Extrigger jumper in its Enable position, a low $\overline{\text{EXTRIG}}$ from the rear interface connector pin sets the output of U1720C high and the microprocessor stops its conversion process after it performs one more complete conversion. After the conversion is complete and the results are properly stored or transferred, the processor sets ESW (Enable Switch) low via the Address Decode circuitry and the output of U1720C is reset low. Normal front-panel operation resumes until another $\overline{\text{EXTRIG}}$ occurs to initiate another triggered conversion.

The In Progress bit, when set high, informs the microprocessor that an A/D conversion is in process. The processor, when controlling the conversion process, monitors this data bit and, when it returns low, knows that the A/D conversion is complete and that the serial data may be read onto the bus via the Data line.

The 17-bit serial data representing an A/D conversion is buffered one bit at a time onto bit 7 of the buffered data bus. The microprocessor, by executing a sequence of read, shift, and store commands, re-assembles this serial data into the parallel format it uses most efficiently.

SWITCHES

The primary function of the \overline{ESW} (Enable Switches) signal is to enable the microprocessor to read the settings of the eight user-definable switches defining the GPIB and SA (Signature Analysis) configuration of the DM 5010.

Though also used to reset the \overline{EXTRIG} status bit as previously described, a low \overline{ESW} from the Address Decode circuitry turns on buffer U1610. This buffers eight bits onto the data bus corresponding to the switch closures of S1515, as defined by the user. Switches S1515-2 through 8 define GPIB address and mode data and will be further discussed in the GPIB description that follows. Switch S1515-1, when closed, causes the microprocessor to stop normal DMM operation and execute a special SA stimulation routine.

GPIB

The GPIB provides a communication and control link so that multiple instruments may interface with each other under the direction of a system controller. The TM 5000-Series power module provides the external GPIB connector as well as the internal interconnection to tie a GPIB-compatible plug-in to the GPIB. All GPIB interface and control functions of the DM 5010 and the TM 5000-Series power modules adhere to IEEE Standard 488-1978.

The IEEE 488-1978 Standard

The IEEE 488-1978 Standard defines a byte-serial, bit-parallel interface system electrically, functionally, and mechanically as well as specifying terminology and system limitations. This system implements a three-wire handshake system with each data transfer from a "talker" to one or more "listeners". A "talker" is a GPIB device sending data while a "listener" is one that receives data from a "talker". All GPIB information is transferred at standard TTL levels using negative logic (i.e., 0=true).

The power module's external GPIB interface has 16 connections that are used for three separate types of functions. Each of these signal lines is connected directly to the DM 5010 and function as described by the IEEE 488-1978 Standard. One additional signal line TE (talk enable), is provided for future use.

Inputs DI01 through DI08 (data input/output) are used specifically for transfer of data between GPIB devices.

Five other lines are used to manage the flow of information over the interface lines. The ATN (Attention) line, when active, disables the current talker and listeners and makes all devices listen to the controller. IFC (Interface Clear) line is used to put the interface system into a known quiescent state. The SRQ (Service Request) line is used to indicate to the controller that a device on the bus is in need of service and an interrupt is requested (the controller determines which devices may talk or listen at any time). The REN (Remote Enable) command selects either a remote or local source of device programming. The EOI (End Or Identify) line is used to signal the end of a multiple byte transfer.

The three remaining lines are associated with the handshake process and are the DAV (Data Valid), NRFD (Not Ready For Data) and NDAC (Data Not Accepted) lines. Their timing relationships during the handshake process are shown in Fig. 4-14. Each data byte transferred by the interface system uses the handshake process to exchange data between source (typically a talker) and acceptor (typically a listener). The following list of events is related by number to the state changes shown in Fig. 4-14 and the flowchart shown in Fig. 4-15.

The Handshake Process

1. The source (talker) initializes the active low DAV (Data Valid) to a high level, indicating that data is not valid.
2. The acceptors (listeners) initialize the active low NRFD (Not Ready For Data) level to a low (none are ready for data) and set the active low NDAC (Data Not Accepted) level to low (none have accepted data).
3. The source checks for an error condition (both NRFD and NDAC at a high level) and then sets a data byte on the DIO (Data In/Out) lines. After the data has been placed on the DIO lines, the source delays to allow the data to settle on these lines.
4. When the acceptors have all indicated readiness to accept the first data byte, the NRFD level goes high.

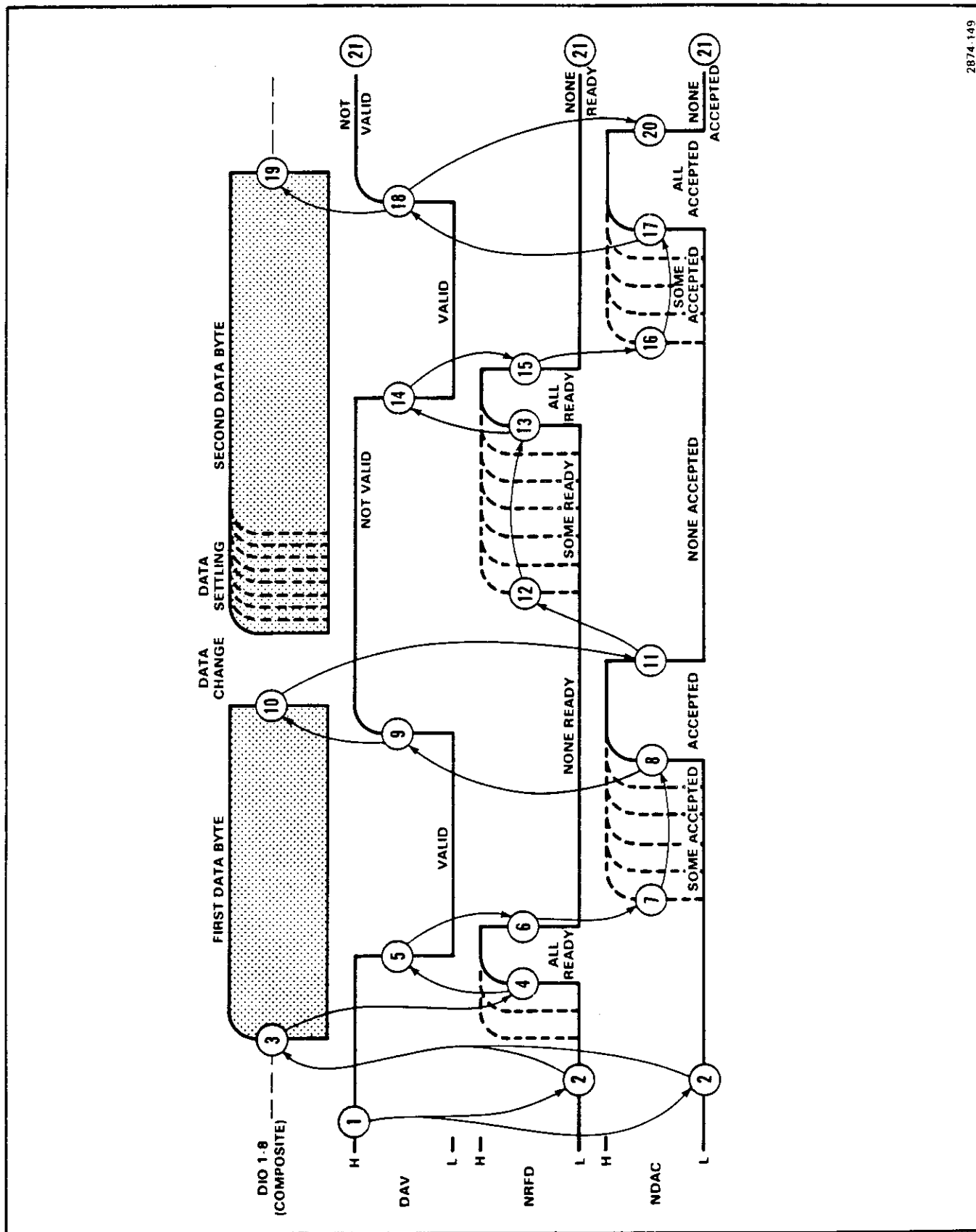

2874-149

Fig. 4-14. GPIB three wire handshake state diagram.

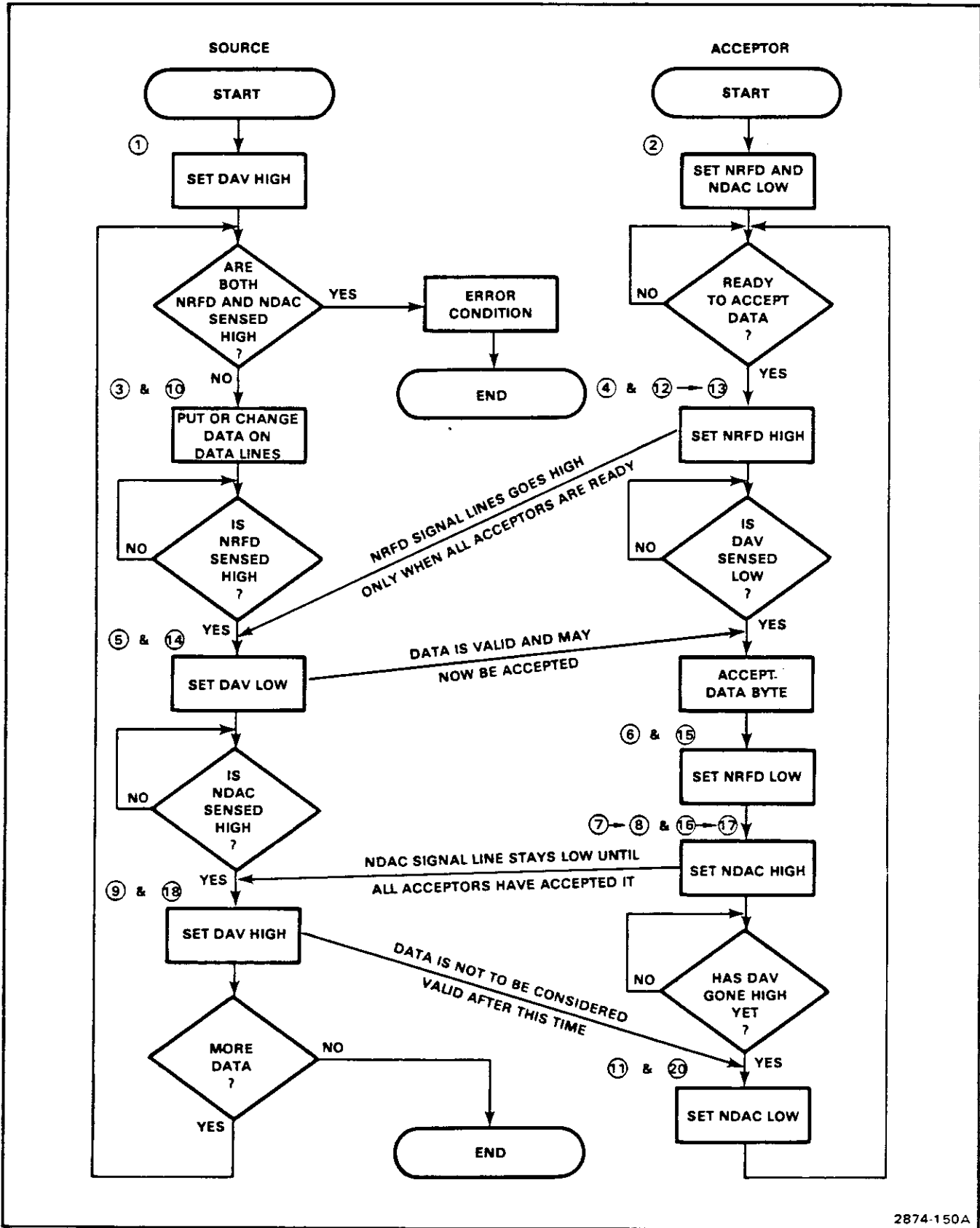

2874-150A

Fig. 4-15. GPIB Handshake flowchart.

Theory of Operation—DM 5010

5. The source, upon sensing the high NRFD level, sets the DAV level to a low, indicating that the data on the DIO lines has settled and is valid.

6. The first (fastest) acceptor sets the NRFD level low, indicating that it is no longer ready for new data, and accepts the present data. The remaining acceptors follow at their own rates.

7. The first acceptor sets its NDAC level to a (passive) high, indicating that it has accepted the data. (NDAC remains low due to the other acceptors actively driving NDAC low. The term "passive" means that if any other device is "actively" driving this line to the opposite state, the passive level is overridden.)

8. As the last (slowest) acceptor accepts the present data, the NDAC level goes to a (passive) high, indicating that all acceptors have accepted the data.

9. The source, having sensed the high NDAC level, sets DAV high. This indicates to the acceptors that the data on the DIO lines must now be considered invalid.

10. The source may change the data on the DIO lines at this time, and now delays to allow this data to settle if changed.

11. The acceptors, upon sensing the high DAV level (step 9, above), set the NDAC level low in preparation for the next cycle. The NDAC line goes low when set by the first acceptor.

12. The first acceptor indicates that it is now ready for the next data byte by setting its NRFD level to a (passive) high. (NRFD remains low due to other acceptors actively driving it low.)

13. When the last acceptor indicates that it is ready for the next data byte, the NRFD level goes (passive) high.

14. The source, sensing that NRFD is high, sets the DAV level low, indicating that the new data on the DIO lines has settled and is valid.

15. The first acceptor sets the NRFD level low, indicating that it is not ready to accept any change of data, then accepts the present data. The other acceptors follow at their own rate.

16. The first acceptor sets its NDAC level to a (passive) high, indicating that it has accepted the data (as in step 7 above).

17. The last acceptor sets the NDAC level (passive) high, indicating that it has accepted the data (as in step 8 above).

18. The source, having sensed that NDAC is high, sets DAV high (as in 9).

19. The source removes the data byte from the DIO signal lines after setting DAV high.

20. The acceptors, upon sensing the high DAV level, set NDAC to a low level in preparation for the next cycle.

21. Note that all three handshake lines are at their initial states (as in steps 1 and 2 above).

GPIO Interface

The purpose of the GPIO Interface is to provide interface between the IEEE 488-1978 Standard bus and the DM 5010 microprocessor. The DM 5010 GPIO interface consists primarily of a 40-pin IC designed specifically for GPIO applications and two bidirectional current buffer ICs.

On the bus side of the GPIO IC, U1105, 16 pins are related directly to the 16 signal lines defined in the IEEE 488-1978 Standard description above. These data, control, and handshake signals are buffered by U1100 and U1110 either from U1105 to the GPIO or vice versa, depending on the T/R (Transmit-Receive) direction control signal. This T/R is also inverted by Q1121 and is provided to the TM 5000-Series power module for future use.

The GPIO IC is a register-oriented device; i.e., its function depends on how its various internal registers have been set. The various control and addressing signals that determine the setting of these registers are applied to the microprocessor side of the IC.

At power up, the negative $\overline{\text{PON}}$ pulse sets all internal registers of the GPIO IC to predefined states. When the Address Decode circuitry detects that a GPIO function is to be performed, it sets $\overline{\text{EGPIO}}$ (Enable GPIO) low and the GPIO IC is enabled.

There are 16 register locations accessible to the microprocessor via the address bus and data bus. These registers store and transfer the control information for the various IC functions as well as IC status and data transfer information. The 16 registers (eight read-only and eight write-only) are addressed by the R/\bar{W} line along with buffered address bits BA0-BA2. Data is written into the write registers or read from the read registers via the data bus coincident with the $B\phi 2$ clock.

The GPIB IC can execute instructions from both the microprocessor data bus and from the General Purpose Interface Bus. As these commands are executed, the various GPIB control and handshake sequences are automatically performed by the GPIB IC, including the proper direction of data transfer on the GPIB (controlled by T/\bar{R}).

Command sequences received via the GPIB usually require that normal microprocessor operation be interrupted. An \bar{IRQ} (Interrupt Request) to the microprocessor is generated by the GPIB IC when such conditions arise.

FRONT-PANEL CONTROL

The Front-Panel Control stage consists primarily of U1605, a specialized IC designed to scan the Front-Panel Switches and control the Front-Panel Display. It provides scanning and reading functions for the various Front-Panel Switches as well as the storage and multiplexing functions required for the Front-Panel Display.

After the PON reset at power up, a scanning sequence begins that checks the Front-Panel Switches for closures. The SC1-SC3 (Scan Column 1-3) lines are the outputs of a free-running binary counter and are later decoded by the Front-Panel Drive circuitry (diagram 11) to scan the eight columns of the Front-Panel Switches matrix. As each column of the matrix is set low (one at a time), the five rows of the matrix are checked to see if a closure is present at the corresponding switch. If a closure is detected, a unique address identifying the switch is written into a temporary storage register within U1605. When the microprocessor executes its front-panel read routine, the register is read via the data bus and the instrument function is changed under firmware control to reflect the depressed switch. All time relationships for the front-panel scanning are derived from the $B\phi 2$ clock.

Data to be displayed by the Front-Panel Display is written from the microprocessor into eight 8-bit storage registers internal to U1605 via the data bus. Each bit, when low, corresponds to an illuminated LED, either in the seven segment displays or the individual status LEDs. The microprocessor formats all numeric and status information before writing it to U1605 so that meaningful displays will result.

The Display is scanned in a manner similar to that of the switch matrix described above. As U1605 performs its continuous scanning functions, each of the seven-segment displays or columns of status LEDs are enabled one at a time, as determined by the SC1-SC3 output lines from U1605 and the Front-Panel Drive circuitry on diagram 11. As each new column or digit is enabled, the contents of the corresponding display register are output onto the CD1-CD8 (cathode drive 1-8) lines. This is the display information previously stored by the microprocessor. The appropriate LEDs are turned on to form either a decimal digit or to light the status indicators.

All front-panel related data transfers occur via the Data Bus and are enabled by a low \bar{EFP} (Enable Front Panel) from the Address Decode circuitry. Writing display information to U1605 is enabled by a low \bar{VW} (Valid Write) to the IC and occurs coincident with the $B\phi 2$ clock. Integrated circuit U1630 controls the reading of the Front-Panel Switches registers. Reading occurs coincident with the $B\phi 2$ clock and one of two registers may be read as selected by BA0, the least significant bit of the address bus.

MAIN INTERCONNECT

The Main Interconnect is a printed circuit board that provides most of the interconnection for the various boards of the DM 5010. Signal origin is indicated by an arrow pointing away from the board connector on which the signal is generated. The Main Interconnect also provides guard and ground shielding.

FRONT-PANEL DRIVE

The Front-Panel Drive stage consists of a 1-of-8 decoder, current buffering circuitry, and a front-panel regulator. The front-panel regulator, U1720, and its associated components regulate the +8 V supply from the power module down to +5 V to provide power for the front-panel circuitry. By using a separate +5 V supply for the front-panel circuitry, switching noise and transients generated by Front-Panel Switches do not affect operation of the rest of the instrument.

The decoder, U1040, converts the binary scanning code from the Front-Panel Control IC to the eight individual lines required to scan the Front-Panel Switches and the Front-Panel Display, as explained in the Front-Panel Control description. The buffering provides current drive levels as required by the switch matrix and LED displays.

FRONT-PANEL SWITCHES

The Front-Panel Switches provide a way for the user to control the operation of the DM 5010.

Forty push button switches are arranged in a 5 X 8 matrix and are continuously scanned under control of the special Front-Panel Control IC and the 1-of-8 decoder in the Front-Panel Drive stage. The 1-of-8 decoder sets each of the eight columns of the matrix low, one at a time, and then each of the five rows are sequentially checked by the Front-Panel Control IC to see if a switch closure is present. After all five rows have been scanned, the next column is set low by the decoder and the sequence is repeated. Switch closure data is stored by the Front-Panel Control IC and is further explained in that description.

FRONT-PANEL DISPLAY

The Front-Panel Display provides a visual indication of instrument status and measurement results to the user. It is comprised of multi-segment displays and individual light-emitting diodes arranged in a matrix configuration. The display is generated in much the same way as when the Front-Panel Switches are scanned.

The Front-Panel Control IC, along with the 1-of-8 decoder in the Front-Panel Drive circuitry, enables one of the multi-segment displays or one of the columns of status LEDs by pulling the associated anodes high through the buffering circuitry on diagram 11. As each group of anodes is enabled, an 8-bit display word associated with the particular column enabled is output from the Front-Panel Control IC on lines CD0-CD7 (Cathode Data 0-Cathode Data 7). This is the data stored earlier by the microprocessor representing the LEDs that should be turned on in any given display digit or status column. The data is buffered by the Front-Panel Drive circuitry and applied to the eight cathode rows. Any cathode that is low when its respective anode is held high will illuminate.

DM 5010 Instrument Interfacing Guide

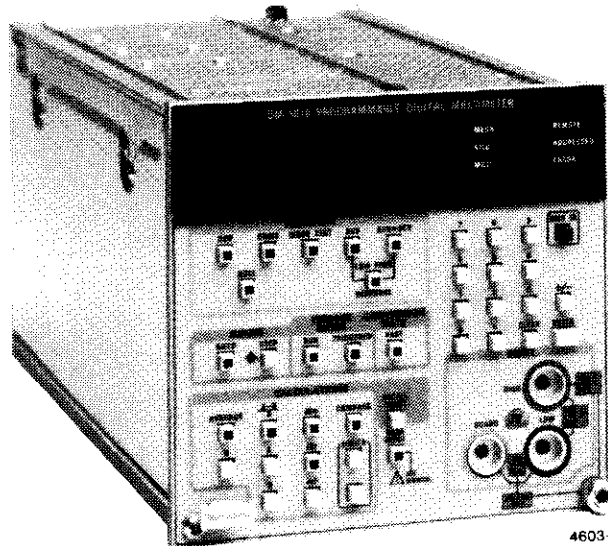

This interfacing guide is designed to help you get started using the DM 5010 Programmable Digital Multimeter with a GPIB controller as quickly and easily as possible. This guide tells you how to set DM 5010 switches for GPIB operation and explains how to communicate with the DM 5010 with a variety of controllers. Sample measurement programs for these controllers are also included.

This guide does not take the place of the operators manual or other documentation supplied with the DM 5010 and your system controller. More complete information in this other documentation will help you get the full benefit of the DM 5010's programmable capabilities.

Setting Up the DM 5010 for GPIB Operation

Connect the TM 5000 power module to your controller with a GPIB cable. The program examples in this guide assume that the DM 5010 and controller are the only instruments on the bus.

Checking the GPIB Address and Terminator.

The DM 5010 primary address is displayed when you press the INST ID button. A decimal point in the display indicates the message terminator switch is set for EOI or LF (no decimal point indicates EOI-only). A minus sign in the display indicates talk-only mode.

The DM 5010 is supplied from the factory set to an address of 16 and to EOI-only for the message terminator.

Setting the Address and Terminator Switches.

The switches that select the GPIB address and terminator are located on a circuit board on the left side of the DM 5010. Because the DM 5010 side cover must be removed, allowing hazardous voltages to be exposed, refer address and terminator selection to qualified personnel only. Both a sticker on the inside of the side cover and Fig. 1 identify the switches and illustrate their meanings. Other switch or strap-selectable options in the DM 5010 are explained in the Operators Manual.

For additional copies, order:
070-4603-00
Product Group 76
First Printing FEB 1983

Tektronix
COMMITTED TO EXCELLENCE

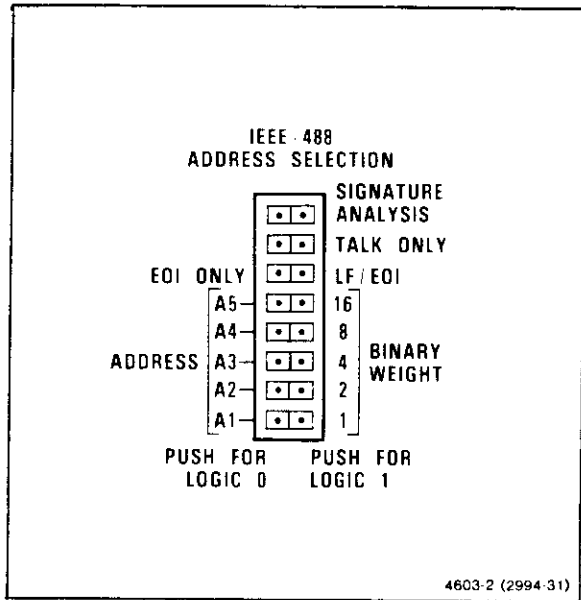

Fig 1. The address and message terminator switches are located on the circuit board on the left side of the DM 5010.

WARNING

Hazardous voltages exist inside the DM 5010. The DM 5010 should be removed and disconnected from the TM 5000 power module (after turning power off) before opening the instrument covers. Internal settings should only be made by qualified personnel.

Valid primary addresses include the range of 0 to 30. (31 effectively disables the DM 5010 from communicating on the GPIB.) If your controller reserves an address for itself, do not set the DM 5010 to that address. This is true of Tektronix 4050-Series controllers, which reserve address 0 for themselves. The Tektronix 4041 defaults to address 30 on power-on, but may be programmed to use any primary address. The DM 5010 ignores secondary addresses.

EOI-only is recommended as the message terminator for use with Tektronix controllers. EOI-or-LF is recommended for use with Hewlett-Packard controllers. (In the latter position, the DM 5010 still recognizes EOI as a terminator and transmits EOI concurrently with the LF character to terminate a message.)

Neither signature analysis nor talk-only modes are used in normal operation with a GPIB controller, so those switches should be set to a logic 0.

Programming The DM 5010

DM 5010 Power-On

The DM 5010 performs a self-test and goes to its default settings on power-on.

Self-Test. During the self-test, all front-panel indicators are lighted. If an internal error is detected, the DM 5010 continuously displays a three-digit error code and turns on the ERROR indicator. See the operators manual for the meaning of any code displayed.

Power-On Settings. Following a successful self-test, the DM 5010 goes to local state with the default settings shown in Table 1 (and defined in Table 2). These settings are restored any time the INIT command is executed.

Power-On SRQ. The DM 5010 asserts SRQ to report power-on status after completing the self-test. This can be handled with a serial poll, although the DM 5010 communicates normally on the GPIB and executes the commands it receives whether or not the SRQ is serviced. Some controllers, such as the 4051 and 4052 when used without the 405XR14 GPIB rompack, require that the program contain an SRQ handler and begin by enabling the handler; otherwise the power-on SRQ will cause the program to halt with the error 'NO SRQ ON UNIT.'

**Table 1
DM 5010 POWER ON SETTINGS**

| Header | Argument |
|---------|----------|
| AVE | 2 |
| CALC | OFF |
| DBR | 1 |
| DCV | -1.E+3 |
| DIGIT | 4.5 |
| DT | OFF |
| LFR | OFF |
| LIMITS | 0,0 |
| MODE | RUN |
| MONITOR | OFF |
| NULL | 0 |
| OPC | OFF |
| OVER | OFF |
| RATIO | 1.0 |
| RQS | ON |
| SOURCE | FRONT |
| USER | OFF |

DM 5010 Messages

Commands are provided to control DM 5010 settings, cause DM 5010 actions, or request status or measurement data. These commands are listed in Table 2. DM 5010 commands begin with a header—a word or abbreviation that describes the function implemented. The command may include one or more arguments, which are delimited from the header by a space; multiple arguments are delimited by a comma. DM 5010 commands can be combined in a message by separating the commands with the message unit delimiter (semicolon). Either upper or lower-case ASCII characters are accepted.

Table 2
DM 5010 COMMANDS AND DESCRIPTIONS
() = Optional

| Header | Argument | Description |
|----------------|----------------|--|
| ACDC (ACD) | <num> | Selects the ACV+DCV function. Argument selects range. Negative or omitted argument selects auto-range. |
| ACV | <num> | Selects the ACV function. Argument selects range. Negative or omitted argument selects auto-range. |
| AVE (AVG) | <num> | Sets the number of conversions used in CALC AVE program. Argument is truncated to integers. |
| AVE? (AVG?) | | Returns "AVE <num>;". |
| CALC | AVE (AVG) | Calculates the average of the next "N" readings. AVE command sets the value of "N". |
| CALC | CMPR (COMP) | Compares input to limits set by LIMITS command. SEND command returns: *3.;" if input is above both limits. *2.;" if input is between or equal to both limits. *1.;" if input is below both limits. * ±1.E+99;" for overrange. DATA returns the out-of-limits measurement. |

Table 2 (cont)

| Header | Argument | Description |
|------------------|----------|--|
| CALC | DBM | Calculates power ratio, referenced to 1 mV dissipated in 600 Ω. Disables CALC DBR. |
| CALC | DBR | Calculates logarithmic ratio of measurement to value of DBR command. Disables CALC DBM. |
| CALC | RATIO | Subtracts offset and divides by scale factor set by RATIO command. |
| CALC | OFF | Disables all calculations. |
| CALC? | | Returns "CALC OFF;" or list of enabled calculations. |
| DATA | | Returns the out-of-limits measurement saved by the MONITOR command. |
| DBR | <num> | Numeric sets value of reference used in CALC DBR command. |
| DBR? | | Returns "DBR <num>;". |
| DCV | <num> | Selects the DCV function. Argument selects range. Negative or omitted argument selects auto-range. |
| DIGIT (DIG) | 3.5 | Selects FAST CONVERSION RATE (3.5 digit resolution). |
| DIGIT (DIG) | 4.5 | Selects normal CONVERSION RATE (4.5 digit resolution). |
| DIGIT? (DIG?) | | Returns "DIGIT 3.5;" or "DIGIT 4.5;;". |
| DIODE (DIO) | | Selects DIODE TEST function. No argument. |
| DT | TRIG | Instrument responds to Group Execute Trigger <GET>. |
| DT | OFF | Disables DT TRIG. Instrument will not respond to Group Execute Trigger <GET>. |
| DT? | | Returns "DT TRIG;" or "DT OFF;;". |

Table 2 (cont)

| Header | Argument | Description |
|-------------------|-----------------|--|
| ERR? | | Returns error code for most recent event reported by serial poll when RQS is ON; with RQS OFF it returns the highest priority status. |
| FUNCT? (FUNC?) | | Returns the current function (DCV, OHMS, DIODE, ACV, ACDC) and range. Negative argument indicates auto-range. |
| ID? | | Returns "ID TEK/ DM 5010,V79.1 FXX;", where XX is the firmware version number. |
| INIT | | Initializes all instrument settings to their power-on settings. See Power On Settings. |
| LFR | ON | Enables the LOW FREQ RESPONSE function. Instrument computes the average of four ACV or ACV + DCV measurements. |
| LFR | OFF | Disables the LOW FREQ RESPONSE function. |
| LFR? | | Returns "LFR OFF;" or "LFR ON;". |
| LIMITS (LIM) | <num>, <num> | Sets limits used in CALC CMPR program. |
| LIMITS? (LIM?) | | Returns "LIMITS <num>, <num>;". |
| MODE | RUN | Selects the free-run (RUN) trigger mode. |
| MODE | TRIG | Selects TRIGGERED trigger mode. Triggers a conversion only upon receipt of one of the following. <ul style="list-style-type: none"> • SEND command • Group Execute Trigger <GET>, only if device trigger (DT) is enabled. • My Talk Address (MTA) with the output unspecified (no query command). |

Table 2 (cont)

| Header | Argument | Description |
|----------------------|----------|--|
| | | • Rear interface trigger (EXTRIG). Requires internal jumper installation. To cause a single trigger, this line must remain low between 0.5 and 10 μ sec. Holding this line low longer causes multiple readings. |
| MODE? | | Returns "MODE RUN;" or "MODE TRIG;". |
| MONITOR ON (MON) | | Enables monitor SRQ. Saves the measurement outside the limits set by the LIMITS command and generates an SRQ. Returns this measurement in response to DATA. Subsequent out-of-limits measurements are not reported until the SRQ is serviced and measurement is returned via DATA command. |
| MONITOR OFF (MON) | | Disables the monitor SRQ. |
| MONITOR? (MON?) | | Returns "MONITOR ON;" or "MONITOR OFF;". |
| NULL | <num> | Sets an offset value and applies it to subsequent measurements. Argument may be any value up to 100% of range. Disable NULL by setting argument to 0, or changing measurement function. |
| NULL? | | Returns "NULL <num>;". |
| OHMS | <num> | Selects OHMS function. Argument selects range. Negative or omitted argument selects auto-range. |
| OPC | ON | Enables operation complete SRQ. DM 5010 asserts SRQ whenever a new measurement is available. |
| OPC | OFF | Disables operation complete SRQ. |
| OPC? | | Returns "OPC OFF;" or "OPC ON;". |

Table 2 (cont)

| Header | Argument | Description |
|---------------|--------------|--|
| OVER | OFF | Disables overrange SRQ (OVER ON). If overranged when talked, returns "1.E+99;" and does not generate an SRQ. |
| OVER | ON | Enables overrange SRQ. If overranged when talked, returns "1.E+99;" and generates an SRQ. |
| OVER? | | Returns "OVER ON;" or "OVER OFF;". |
| RATIO (RAT) | <num>, <num> | Sets values for offset and scale used in CALC RATIO command. First argument is for scale, second for offset. |
| RATIO? (RAT?) | | Returns "RATIO <num>, <num>;". |
| RDY? | | Returns "RDY 0;" if a measurement is in progress or if the instrument is waiting for a trigger. Returns "RDY 1;" if a measurement is available. Also see OPC ON. |
| RQS | ON | Enables instrument to generate service requests. |
| RQS | OFF | Disables all SRQ's. Instrument responds to ERR? without first being serial polled. |
| RQS? | | Returns "RQS OFF;" or "RQS ON;". |
| SEND (SEN) | | Returns latest measurement. If no measurement is available, the instrument triggers a measurement and then outputs it. If CALC CMPR is enabled, returns 1, 2, or 3 to indicate relationship of measurement to LIMITS. See CALC CMPR. |
| SET? | | Returns all instrument settings that may be queried. See Power On Settings. |
| SOURCE (SOUR) | FRONT | Connects front panel connector inputs. |

Table 2 (cont)

| Header | Argument | Description |
|-----------------|----------|---|
| SOURCE (SOUR) | REAR | Connects rear interface connector inputs. |
| SOURCE? (SOUR?) | | Returns "SOURCE FRONT;" or "SOURCE REAR;". |
| TEST | | Returns 0 if calculation checksum is correct; 351 if erroneous. |
| USER | ON | Enables INST ID button service request. |
| USER | OFF | Disables INST ID button service request. |
| USER? | | Returns "USER ON;" or "USER OFF;". |

Sending Messages to the DM 5010

Most GPIB controllers provide a high-level statement that allows you to transfer device-dependent messages to the DM 5010. In the 4050-Series and the 4041, it's the PRINT statement.

4050-Series:

```
170 PRINT @16:"ACV;LFR ON"
```

4041:

```
170 Print #16:"ACV;LFR ON"
```

A useful variation assigns the DM 5010 address to a variable and inserts that variable in the PRINT statement in place of the number for the address. This works with either the 4050-Series or 4041 and allows you to change the program to work with the DM 5010 set to other addresses by changing only the statement that assigns the variable.

4050:

```
200 D=16
210 PRINT @D:"ACV;LFR ON"
```

4041:

```
200 D##=16
210 Print #D##:"ACV;LFR ON"
```

Notice that the DM 5010 message (what's inside the quote marks) is the same in all of the above examples. The rest of each example varies to match the PRINT statement syntax designed into each controller as illustrated in Fig. 2. This suggests that once you understand your controller's output and input statements, it's just a matter of plugging in the DM 5010 commands you need.

| | |
|-------------------|-----------------------|
| 4050-Series BASIC | PRINT @5:"RQS ON" |
| 4041 BASIC | PRINT #5:"RQS ON" |
| HP-85 BASIC | OUTPUT 705 ; "RQS ON" |
| FLUKE 1720A BASIC | PRINT @5%,"RQS ON" |
| HP 9826 BASIC | OUTPUT 705;"RQS ON" |

4603-5

Fig. 2. A message to a GPIB device is contained within the controller's GPIB output statement. The statement is composed of three parts: the keyword, the address or logical unit number, and the device-dependent message. All the statements shown send the same standard Tektronix Codes & Formats message (RQS ON) that enables SRQ interrupts. All send the message to an instrument with primary address 5. The difference lies in the syntax of the statement required for a particular controller.

Getting DM 5010 Current Settings

DM 5010 queries or output commands (such as FUNCT?, MODE?, or SEND) prepare the instrument for output, but do not start such output. The DM 5010 waits until it sees its talk address to begin sending the requested data. This is accomplished by the INPUT statement.

4050-Series:

```
280 PRINT @16:"FUNC?"
290 INPUT @16:F$
```

4041:

```
290 Input #16 prompt "FUNC?":fncion$
```

All instrument settings can be obtained in one message. Just dimension a string large enough (300 characters is plenty) and input the settings string.

4050-Series:

```
330 DIM S$(300)
340 PRINT @16:"SET?"
350 INPUT @16:S$
```

4041:

```
330 Dim settings$ to 300
340 Input #16 prompt "SET?":settings$
```

You can restore the settings you input from the DM 5010 by sending back the settings string.

4050-Series:

```
380 PRINT @16:S$
```

4041:

```
380 Print #16:settings$
```

Getting DM 5010 Measurements

Getting measurements from the DM 5010 is even easier than getting settings data. Sending the DM 5010 talk address, which INPUT does, is enough to cause the DM 5010 to output a reading. (The DM 5010 responds with a reading if it has not been told by a query command to respond with some other output.) The DM 5010 sends the reading as ASCII numeric characters, which may be input into a character string or numeric variable. The variable and its type are specified after the colon in the INPUT statement.

4050-Series:

```
430 INPUT @16:R
```

4041:

```
430 Input #16:readins
```

If a reading is not available, say the DM 5010 was set to triggered mode but no reading was triggered, the INPUT statement causes the DM 5010 to trigger a reading and output it as soon as it is available. Meanwhile, it holds off further GPIB activity by halting the handshake. This may be undesirable if the DM 5010 is set to average many readings before it can output a response. The SEND command is provided for this reason. Its use is illustrated in the sample measurement program later in this guide. SEND allows the program to handle other events or do other processing while many readings are averaged. It also avoids a timeout, which occurs if the DM 5010 is talked but cannot supply output within five seconds.

If the program does request a long averaging operation, does not use SEND, and attempts to INPUT the reading before it is ready, it can cause the DM 5010 to time out. If a time out occurs, the DM 5010 does not

hold up bus traffic any longer; it outputs a byte with all bits set to one (FF hex) and asserts EOI concurrently. This does not change the value stored in the INPUT target variable. If the variable was undefined, it remains undefined. This causes an error if the variable is numeric and it is subsequently used in an output statement or a calculation.

Because the DM 5010 returns a very large number (1.E+99) to indicate an overrange condition, it is necessary to define variables used for readings in the 4041 as long floating point. Such a variable is used in the 4041 sample measurement program.

Using DM 5010 Interrupts

Programmable interrupts are provided in the DM 5010 to inform the controller of asynchronous events, such as operation complete, command errors, overranging, or out-of-limits reading in the compare mode. If the DM 5010 is set to report an event, it asserts SRQ when it detects that event and sets its

status byte and error code appropriately. The status byte returned in response to a serial poll and the error code returned in response to an error query (ERR?) correspond to the events shown in Table 3. The error query obtains more detail in the case of abnormal events and some normal events. For instance, in the case of a command error, was it a problem with a header, argument, or delimiter? You can find out from the error code.

Here are typical SRQ handlers that alert you to a reporting instrument's address, status, and error code with a message on your console. The error code is helpful during debugging because it identifies the specific command or execution problem should one occur. To use an SRQ handler, you must link it and enable it as shown in the statements at lines 120 and 130. The sample measurement program does not use the error query because the information that is needed (operation complete) is available from the status byte. It prints the status byte as a failsafe measure only if it is other than the one expected.

4050-Series with 405XR14 Rompack:

```
120 ON SRQ THEN 470
130 CALL "SRQON"
140 REM
150 REM
450 REM
460 STOP
465 REM SERIAL POLL OF ADDRESS 16 ONLY
470 POLL A,S;16
475 PRINT @16:"ERR?"
480 INPUT @16:E
490 PRINT "STATUS=";S,"ERROR=";E
500 RETURN
```

4041:

```
120 On sra then gosub dopoll
130 Enable sra
140 !
150 !
450 !
460 Stop "End of 4041 example program statements."
470 Dopoll: poll stabyt,addr;16.
480 Input #addr prompt "ERR?":errnum
490 Print "STATUS=";stabyt,"ADDRESS=";addr,"ERROR=";errnum
500 Resume
```

**Table 3
ERROR QUERY AND STATUS INFORMATION**

| Abnormal Events | Error Query Response | Serial Poll Response^a |
|---|-----------------------------|---|
| Command Errors: | | |
| Invalid command header | 101 | 97 |
| Header delimiter error | 102 | 97 |
| Argument error | 103 | 97 |
| Argument delimiter error | 104 | 97 |
| Missing argument | 106 | 97 |
| Invalid message unit delimiter | 107 | 97 |
| Execution Errors: | | |
| Not executable in local mode | 201 | 98 |
| Settings lost due to <i>rtf</i> | 202 | 98 |
| Input and output buffers full | 203 | 98 |
| Argument out of range | 205 | 98 |
| Group Execute Trigger ignored | 206 | 98 |
| Not in calibrate mode | 231 | 98 |
| Beyond calibration or null capability | 232 | 98 |
| Internal Errors: | | |
| Interrupt fault | 301 | 99 |
| System error | 302 | 99 |
| Math pack error | 303 | 99 |
| Converter time-out | 311 | 99 |
| Front panel time-out | 317 | 99 |
| Bad ohms calibration constant | 318 | 99 |
| Calibration checksum error | 351 | 99 |
| Normal Events | | |
| System Events: | | |
| Power on | 401 | 65 |
| Operation complete | 402 | 66 |
| ID user request | 403 | 67 |
| Internal Warning: | | |
| Over-range | 601 | 102 |
| Device Status: | | |
| Reading available | 0 | 132 |
| Waiting for trigger | 0 | 136 |
| Reading available and waiting for trigger | 0 | 140 |
| Below limits | 701 | 193 |
| Above limits | 703 | 195 |
| No Errors or Events | 0 | 128 |

^aIf the instrument is busy, it returns a decimal number 16 higher than the number listed.

DM 5010 Data Processing

Functions built into the DM 5010 allow you to obtain answers that are already processed or corrected in a number of ways. For instance, ohms readings can be offset by NULL to take into account lead resistance. Any reading can be scaled according to the formula $(x-b)/a$; this converts a voltage reading across a resistor to current if b is set to zero and a to the resistor's ohms value. Voltage readings can be returned in dB or dBr (dB compared to a reference). Just insert the processing command selected from the command table in this guide into set-up messages sent to the DM 5010. An example using the averaging function is shown in the sample measurement program.

DM 5010 Response to Interface Messages

The following program sequences show various interface messages transmitted to the DM 5010.

The DM 5010 responds to DCL (and SDC if listen addressed) by clearing its Input and Output Buffers and any unexecuted setting commands in its Pending Settings Buffer, along with any errors or events waiting to be reported (except power-on).

GET triggers a reading in device trigger mode if the instrument receives the message while listen addressed. It is used with the MODE TRIG and DT TRIG commands.

LLO locks out the operator from restoring local (front-panel) control when the instrument is under remote control.

GTL restores local control if the instrument receives the message while listen addressed.

See the DM 5010 Operators Manual for a full discussion of how the instrument responds to interface messages.

405XR14:

```

100 REM
110 REM
120 REM
130 REM
140 A=16
150 REM
160 REM          Send Listen Address (MLA)
170 CALL "LISTEN";A
180 REM          Send Unlisten (UNL)
190 CALL "UNL"
200 REM          Send Talk Address
210 CALL "TALK";A
220 REM          Send Untalk
230 CALL "UNT"
240 REM          Send Device Clear
250 CALL "DCL"
260 REM          Send MLA, Selected Device Clear, UNL
270 CALL "SDC";A
280 REM          Send Local Lockout
290 CALL "LLO"
300 REM          Send MLA, Go to Local, UNL
310 CALL "GTL";A
320 REM          Send MLA, Group Execute Trisser, UNL
330 CALL "GET";A
340 REM          Unassert REN
350 CALL "LOCS"

```

4041:

```

130      Pri_addr=16 !      primary bus address
140      !
150      !
160 Listen:      wbyte atn(pri_addr+32) !      Send Listen Address (MLA)
170      !
180 Unlisten:    wbyte atn(unl) !      Send Unlisten (UNL)
190      !
200 Talk:        wbyte atn(pri_addr+64) !      Send Talk Address
210      !
220 Untalk:      wbyte atn(unt) !      Send Untalk
230      !
240 Devclear:    wbyte dcl !      Send Device Clear
250      !
260 Selctclr:    wbyte sdc(pri_addr),atn(unl) ! Send MLA, Selected Device
270      !                                     Clear, UNL
280 Lockout:     wbyte llo !      Send Local Lockout
290      !
300 Gtlocal:     wbyte stl(pri_addr),atn(unl) ! Send MLA, Go to Local, UNL
310      !
320 Trisser:     wbyte set(pri_addr),atn(unl) ! Send MLA, Group Execute
330      !                                     Trisser, UNL
340 Loclstat:    wbyte ren(0),ren(1) !      Pulse unassert REN line

```

Sample Measurement Program

The following program makes a series of DM 5010 measurements to illustrate command i/o and various measurement triggering modes.

Figs. 3 and 4 are typical output from the programs.

405XR14:

```
100 REM ++++++
110 REM :::::::::: DM 5010/4050--SERIES MEASUREMENT PROGRAM ::::::::::
120 REM ::::::::::
130 REM
140 REM BY Jim Kimball, GPI Marketing, 10/15/82, update 11/17/82
150 REM
160 REM Copyright (c) 1982, Tektronix, Inc. All rights reserved. This
170 REM software is provided on an "as is" basis without warranty of any
180 REM kind. It is not supported.
190 REM
200 REM This software may be reproduced without prior permission, in
210 REM whole or in part. Copies must include the above copyright
220 REM and warranty notice.
230 REM
240 REM REQUIRED EQUIPMENT
250 REM DM 5010 in TM 5000 mainframe.
260 REM Program assumes no other instruments on the bus.
270 REM 4050-Series controller with R14 GPIB Enhancement rompack
280 REM
290 REM PURPOSE:
300 REM Inputs four readings, using four different DM 5010 acquisition
310 REM modes. Prints readings on screen.
320 REM
330 REM OPERATING PROCEDURE:
340 REM Connect 4050 Controller and TM 5000 mainframe with GPIB cable.
350 REM DM 5010 must be set for primary address of 16 or
360 REM change line that assigns d=16.
370 REM Enter and run program (no other program segment required).
380 REM
390 REM PROGRAM FUNCTIONS:
400 REM
410 REM Prepares DM 5010 for measurement and queries id
420 REM Reads whatever measurement is available
430 REM Triggers a reading with the INPUT statement
440 REM Reads after GET trigger in device trigger mode
450 REM Gets average of 20 DM 5010 readings using SEND
460 REM General-purpose SRQ handler
470 REM
480 REM -+++++
490 INIT
500 PAGE
510 PRINT "GDM 5010 MAKING MEASUREMENTS."
520 REM Assign DM 5010 factory-set address of 16
530 D=16
540 ON SRQ THEN 950
550 CALL "SRQON"
560 REM
570 REM Setup DM 5010; expand as needed
580 PRINT @D:"init"
```

```
590 REM          Query id
600 PRINT @D:"id?"
610 INPUT @D:I$
620 PRINT I$
630 REM
640 REM          Get continuous mode readings
650 PRINT @D:"mode run"
660 INPUT @D:M
670 PRINT "Continuous Mode: ";M
680 REM
690 REM          Get triggered readings
700 PRINT @D:"mode tris"
710 INPUT @D:M
720 PRINT "Triggered Mode: ";M
730 REM
740 REM          Get triggered readings using device trigger
750 PRINT @D:"dt tris"
760 REM Allow DM to set up for GET
770 CALL "WAIT",0.4
780 CALL "set";D
790 INPUT @D:M
800 PRINT @D:"dt off"
810 PRINT "Device Trigger Mode: ";M
820 REM
830 REM          Get averaged reading
840 REM          Inform operator of delay
850 PRINT "Waiting for average..."
860 PRINT @D:"ave 20;calc ave;opc on;send"
870 WAIT
880 IF NOT(S=66 OR S=82) THEN 870
890 INPUT @D:M
900 PRINT @D:"opc off"
910 PRINT "Average of 20 readings: ";M
920 PRINT "Program complete."
930 END
940 REM          SRQ handler
950 POLL A,S;D
960 IF S=66 OR S=82 THEN 980
970 PRINT "Status=";S
980 RETURN
```

```
DM 5010 MAKING MEASUREMENTS.
ID TEK/DM5010,U79.1,F00;
Continuous Mode:  0.18635
Triggered Mode:  -0.0413
Device Trigger Mode:  -0.13415
Waiting for average...
Average of 20 readings:  -0.19933
Program complete.
```

4603-3

Fig. 3. Screen output from 4050-Series sample measurement program.

DM 5010 Instrument Interfacing Guide

4041:

```
100 !+::::::::::::::::::::::::::::::::::::::::::::::::::::::::::::::::+
110 ! ::::::::::::::: DM 5010/4041 MEASUREMENT PROGRAM :::::::::::::::
120 ! ::::::::::::::::::::::::::::::::::::::::::::::::::::::::::+
130 !
140 ! By Jim Kimball, GPI Marketing, 9/24/82, revised 11/18/82
150 !
160 ! Copyright (c) 1982, Tektronix, Inc. All rights reserved. This
170 ! software is provided on an "as is" basis without warranty of any
180 ! kind. It is not supported.
190 !
200 ! This software may be reproduced without prior permission, in whole or
210 ! in part. Copies must include the above copyright and warranty notice.
220 !
230 ! REQUIRED EQUIPMENT:
240 ! DM 5010 in TM 5000 mainframe.
250 ! Program assumes no other instruments on the GPIB.
260 ! 4041 (V1.1) -- console may be either front panel or terminal (comm:).
270 !
280 ! PURPOSE:
290 ! Inputs four readings, using four different DM 5010 acquisition modes.
300 ! Prints readings on 4041 printer.
310 !
320 ! OPERATING PROCEDURE:
330 ! Connect 4041 and TM 5000 mainframe with GPIB cable.
340 ! DM 5010 must be set for primary address of 16 or change line Addr_set
350 ! Enter and type run (no other program segment required; contains main program)
360 ! Console may be either "FRTM:" or "COMM:"
370 !
380 ! PROGRAM LABELS:
390 !
400 ! Initset: prepares DM 5010 for measurement and queries id
410 ! Runmode: reads whatever measurement is available
420 ! Trisread: triggers a reading with the INPUT statement
430 ! Dtread: reads on GET trigger in device trigger mode
440 ! Average: sets average of 20 DM 5010 readings using SEND
450 ! Polldm: general purpose sra handler
460 !
470 !-::::::::::::::::::::::::::::::::::::::::::::::::::::::::::::::::-
480 Init var all
490 Print "^GDM 5010 making measurements."
500 Addr set: dmm=16 ! This is factory-set primary address
510 Open #101:"Prin:" ! Open LU for 4041 printer
520 Long measure ! Long floating point handles 1.E+99 if DMM overranges
530 Integer dmm,status,address
540 On sra then sosub polldm ! Links sra handler
550 Enable sra ! Enables sra interrupt
560 !
570 Initset: print #dmm:"init" ! Expand to cover measurement needs
580 Input #dmm:prompt "id?":id$ ! Query DM id
590 Print #101:id$ ! Print response on 4041 printer
600 !
610 Runmode: print #dmm:"mode run"
620 Input #dmm:measure ! Get whatever reading is available
630 Print #101:"Continuous Mode",measure
640 !
650 Trisread: print #dmm:"mode tris"
660 Input #dmm:measure ! INPUT statement talks DMM, triggers reading
670 Print #101:"Trisseed Mode",measure
680 !
690 Dtread: print #dmm:"dt tris"
700 Wait 0.4 ! Let DM set up for GET
710 Wbyte set(dmm),atn(unl) ! Send GET to DM 5010 to start reading
720 Input #dmm:measure ! Gets reading as soon as ready
```

```
730   Print #dmm:"dt off"
740   Print #101:"Device Trisster Mode",measure
750   !
760 Average:   print "OGWaiting for average" !      Inform operator of delay
770   Status=0 !      Clear variable so set only by next serial poll
780   Print #dmm:"ave 20;calc ave;opc on;send"
790   Wait ! for OPC
800   If not(status=66 or status=82) then goto 790
810   Input #dmm:measure
820   Print #dmm:"opc off"
830   Print #101:"Average of 20",measure
840   !
850   Stop "Program complete"
860   !
870 Poll:dm:   poll status,address
880   If not(status=66 or status=82) then print "Status=";status
890   Resume
900   End
```

```
ID TEK/DM5010,U79.1,
F00;
Continuous Mode 0.06
93200
Triggered Mode -0.07
49500
Device Trigger Mode
-0.1003200
Average of 20 -0.122
5400
```

4603-4

Fig. 4. Printer output from 4041 sample measurement program.

ASCII & GPIB CODE CHART

| BITS | B7 B6 B5 | | B4 B3 B2 B1 | | B7 B6 B5 | | B4 B3 B2 B1 | | B7 B6 B5 | | B4 B3 B2 B1 | | | | | |
|---------|------------|------------|--------------|-------------|-----------------|----------|-------------|---------------------|------------|----|-------------|-----|------------|-----|-----|-----|
| | CONTROL | | | | NUMBERS SYMBOLS | | | | UPPER CASE | | | | LOWER CASE | | | |
| | 0 | 20 | 40 | 60 | 100 | 120 | 140 | 160 | 0 | 20 | 40 | 60 | 0 | 20 | 40 | 60 |
| ⊘ ⊘ ⊘ ⊘ | NUL | DLE | SP | 0 | @ | P | ' | p | | | | | | | | |
| | 1 | 21 | 41 | 61 | 101 | 121 | 141 | 161 | 0 | 10 | 20 | 30 | 40 | 50 | 60 | 70 |
| ⊘ ⊘ ⊘ 1 | SOH | DC1 | ! | 1 | A | Q | a | q | | | | | | | | |
| | 2 | 22 | 42 | 62 | 102 | 122 | 142 | 162 | 1 | 11 | 21 | 31 | 41 | 51 | 61 | 71 |
| ⊘ ⊘ 1 ⊘ | STX | DC2 | " | 2 | B | R | b | r | | | | | | | | |
| | 3 | 23 | 43 | 63 | 103 | 123 | 143 | 163 | 2 | 12 | 22 | 32 | 42 | 52 | 62 | 72 |
| ⊘ ⊘ 1 1 | ETX | DC3 | # | 3 | C | S | c | s | | | | | | | | |
| | 4 | 24 | 44 | 64 | 104 | 124 | 144 | 164 | 3 | 13 | 23 | 33 | 43 | 53 | 63 | 73 |
| ⊘ 1 ⊘ ⊘ | EOT | DC4 | \$ | 4 | D | T | d | t | | | | | | | | |
| | 5 | 25 | 45 | 65 | 105 | 125 | 145 | 165 | 4 | 14 | 24 | 34 | 44 | 54 | 64 | 74 |
| ⊘ 1 ⊘ 1 | ENQ | NAK | % | 5 | E | U | e | u | | | | | | | | |
| | 6 | 26 | 46 | 66 | 106 | 126 | 146 | 166 | 5 | 15 | 25 | 35 | 45 | 55 | 65 | 75 |
| ⊘ 1 1 ⊘ | ACK | SYN | & | 6 | F | V | f | v | | | | | | | | |
| | 7 | 27 | 47 | 67 | 107 | 127 | 147 | 167 | 6 | 16 | 26 | 36 | 46 | 56 | 66 | 76 |
| ⊘ 1 1 1 | BEL | ETB | ' | 7 | G | W | g | w | | | | | | | | |
| | 8 | 28 | 48 | 68 | 108 | 128 | 148 | 168 | 7 | 17 | 27 | 37 | 47 | 57 | 67 | 77 |
| 1 ⊘ ⊘ ⊘ | BS | CAN | (| 8 | H | X | h | x | | | | | | | | |
| | 9 | 29 | 49 | 69 | 109 | 129 | 149 | 169 | 8 | 18 | 28 | 38 | 48 | 58 | 68 | 78 |
| 1 ⊘ ⊘ 1 | HT | EM |) | 9 | I | Y | i | y | | | | | | | | |
| | 10 | 30 | 50 | 70 | 110 | 130 | 150 | 170 | 9 | 19 | 29 | 39 | 49 | 59 | 69 | 79 |
| 1 ⊘ 1 ⊘ | LF | SUB | * | : | J | Z | j | z | | | | | | | | |
| | 11 | 31 | 51 | 71 | 111 | 131 | 151 | 171 | 10 | 20 | 30 | 40 | 50 | 60 | 70 | 80 |
| 1 ⊘ 1 1 | VT | ESC | + | ; | K | [| k | { | | | | | | | | |
| | 12 | 32 | 52 | 72 | 112 | 132 | 152 | 172 | 11 | 21 | 31 | 41 | 51 | 61 | 71 | 81 |
| 1 1 ⊘ ⊘ | FF | FS | , | < | L | \ | l | | | | | | | | | |
| | 13 | 33 | 53 | 73 | 113 | 133 | 153 | 173 | 12 | 22 | 32 | 42 | 52 | 62 | 72 | 82 |
| 1 1 ⊘ 1 | CR | GS | - | = | M |] | m | } | | | | | | | | |
| | 14 | 34 | 54 | 74 | 114 | 134 | 154 | 174 | 13 | 23 | 33 | 43 | 53 | 63 | 73 | 83 |
| 1 1 1 ⊘ | SO | RS | . | > | N | ^ | n | ~ | | | | | | | | |
| | 15 | 35 | 55 | 75 | 115 | 135 | 155 | 175 | 14 | 24 | 34 | 44 | 54 | 64 | 74 | 84 |
| 1 1 1 1 | SI | US | / | ? | O | _ | o | DEL (RUBOUT) | | | | | | | | |
| | 16 | 36 | 56 | 76 | 116 | 136 | 156 | 176 | 15 | 25 | 35 | 45 | 55 | 65 | 75 | 85 |
| | 17 | 37 | 57 | 77 | 117 | 137 | 157 | 177 | 16 | 26 | 36 | 46 | 56 | 66 | 76 | 86 |
| | 18 | 38 | 58 | 78 | 118 | 138 | 158 | 178 | 17 | 27 | 37 | 47 | 57 | 67 | 77 | 87 |
| | 19 | 39 | 59 | 79 | 119 | 139 | 159 | 179 | 18 | 28 | 38 | 48 | 58 | 68 | 78 | 88 |
| | 20 | 40 | 60 | 80 | 120 | 140 | 160 | 180 | 19 | 29 | 39 | 49 | 59 | 69 | 79 | 89 |
| | 21 | 41 | 61 | 81 | 121 | 141 | 161 | 181 | 20 | 30 | 40 | 50 | 60 | 70 | 80 | 90 |
| | 22 | 42 | 62 | 82 | 122 | 142 | 162 | 182 | 21 | 31 | 41 | 51 | 61 | 71 | 81 | 91 |
| | 23 | 43 | 63 | 83 | 123 | 143 | 163 | 183 | 22 | 32 | 42 | 52 | 62 | 72 | 82 | 92 |
| | 24 | 44 | 64 | 84 | 124 | 144 | 164 | 184 | 23 | 33 | 43 | 53 | 63 | 73 | 83 | 93 |
| | 25 | 45 | 65 | 85 | 125 | 145 | 165 | 185 | 24 | 34 | 44 | 54 | 64 | 74 | 84 | 94 |
| | 26 | 46 | 66 | 86 | 126 | 146 | 166 | 186 | 25 | 35 | 45 | 55 | 65 | 75 | 85 | 95 |
| | 27 | 47 | 67 | 87 | 127 | 147 | 167 | 187 | 26 | 36 | 46 | 56 | 66 | 76 | 86 | 96 |
| | 28 | 48 | 68 | 88 | 128 | 148 | 168 | 188 | 27 | 37 | 47 | 57 | 67 | 77 | 87 | 97 |
| | 29 | 49 | 69 | 89 | 129 | 149 | 169 | 189 | 28 | 38 | 48 | 58 | 68 | 78 | 88 | 98 |
| | 30 | 50 | 70 | 90 | 130 | 150 | 170 | 190 | 29 | 39 | 49 | 59 | 69 | 79 | 89 | 99 |
| | 31 | 51 | 71 | 91 | 131 | 151 | 171 | 191 | 30 | 40 | 50 | 60 | 70 | 80 | 90 | 100 |
| | 32 | 52 | 72 | 92 | 132 | 152 | 172 | 192 | 31 | 41 | 51 | 61 | 71 | 81 | 91 | 101 |
| | 33 | 53 | 73 | 93 | 133 | 153 | 173 | 193 | 32 | 42 | 52 | 62 | 72 | 82 | 92 | 102 |
| | 34 | 54 | 74 | 94 | 134 | 154 | 174 | 194 | 33 | 43 | 53 | 63 | 73 | 83 | 93 | 103 |
| | 35 | 55 | 75 | 95 | 135 | 155 | 175 | 195 | 34 | 44 | 54 | 64 | 74 | 84 | 94 | 104 |
| | 36 | 56 | 76 | 96 | 136 | 156 | 176 | 196 | 35 | 45 | 55 | 65 | 75 | 85 | 95 | 105 |
| | 37 | 57 | 77 | 97 | 137 | 157 | 177 | 197 | 36 | 46 | 56 | 66 | 76 | 86 | 96 | 106 |
| | 38 | 58 | 78 | 98 | 138 | 158 | 178 | 198 | 37 | 47 | 57 | 67 | 77 | 87 | 97 | 107 |
| | 39 | 59 | 79 | 99 | 139 | 159 | 179 | 199 | 38 | 48 | 58 | 68 | 78 | 88 | 98 | 108 |
| | 40 | 60 | 80 | 100 | 140 | 160 | 180 | 200 | 39 | 49 | 59 | 69 | 79 | 89 | 99 | 109 |
| | 41 | 61 | 81 | 101 | 141 | 161 | 181 | 201 | 40 | 50 | 60 | 70 | 80 | 90 | 100 | 110 |
| | 42 | 62 | 82 | 102 | 142 | 162 | 182 | 202 | 41 | 51 | 61 | 71 | 81 | 91 | 101 | 111 |
| | 43 | 63 | 83 | 103 | 143 | 163 | 183 | 203 | 42 | 52 | 62 | 72 | 82 | 92 | 102 | 112 |
| | 44 | 64 | 84 | 104 | 144 | 164 | 184 | 204 | 43 | 53 | 63 | 73 | 83 | 93 | 103 | 113 |
| | 45 | 65 | 85 | 105 | 145 | 165 | 185 | 205 | 44 | 54 | 64 | 74 | 84 | 94 | 104 | 114 |
| | 46 | 66 | 86 | 106 | 146 | 166 | 186 | 206 | 45 | 55 | 65 | 75 | 85 | 95 | 105 | 115 |
| | 47 | 67 | 87 | 107 | 147 | 167 | 187 | 207 | 46 | 56 | 66 | 76 | 86 | 96 | 106 | 116 |
| | 48 | 68 | 88 | 108 | 148 | 168 | 188 | 208 | 47 | 57 | 67 | 77 | 87 | 97 | 107 | 117 |
| | 49 | 69 | 89 | 109 | 149 | 169 | 189 | 209 | 48 | 58 | 68 | 78 | 88 | 98 | 108 | 118 |
| | 50 | 70 | 90 | 110 | 150 | 170 | 190 | 210 | 49 | 59 | 69 | 79 | 89 | 99 | 109 | 119 |
| | 51 | 71 | 91 | 111 | 151 | 171 | 191 | 211 | 50 | 60 | 70 | 80 | 90 | 100 | 110 | 120 |
| | 52 | 72 | 92 | 112 | 152 | 172 | 192 | 212 | 51 | 61 | 71 | 81 | 91 | 101 | 111 | 121 |
| | 53 | 73 | 93 | 113 | 153 | 173 | 193 | 213 | 52 | 62 | 72 | 82 | 92 | 102 | 112 | 122 |
| | 54 | 74 | 94 | 114 | 154 | 174 | 194 | 214 | 53 | 63 | 73 | 83 | 93 | 103 | 113 | 123 |
| | 55 | 75 | 95 | 115 | 155 | 175 | 195 | 215 | 54 | 64 | 74 | 84 | 94 | 104 | 114 | 124 |
| | 56 | 76 | 96 | 116 | 156 | 176 | 196 | 216 | 55 | 65 | 75 | 85 | 95 | 105 | 115 | 125 |
| | 57 | 77 | 97 | 117 | 157 | 177 | 197 | 217 | 56 | 66 | 76 | 86 | 96 | 106 | 116 | 126 |
| | 58 | 78 | 98 | 118 | 158 | 178 | 198 | 218 | 57 | 67 | 77 | 87 | 97 | 107 | 117 | 127 |
| | 59 | 79 | 99 | 119 | 159 | 179 | 199 | 219 | 58 | 68 | 78 | 88 | 98 | 108 | 118 | 128 |
| | 60 | 80 | 100 | 120 | 160 | 180 | 200 | 220 | 59 | 69 | 79 | 89 | 99 | 109 | 119 | 129 |
| | 61 | 81 | 101 | 121 | 161 | 181 | 201 | 221 | 60 | 70 | 80 | 90 | 100 | 110 | 120 | 130 |
| | 62 | 82 | 102 | 122 | 162 | 182 | 202 | 222 | 61 | 71 | 81 | 91 | 101 | 111 | 121 | 131 |
| | 63 | 83 | 103 | 123 | 163 | 183 | 203 | 223 | 62 | 72 | 82 | 92 | 102 | 112 | 122 | 132 |
| | 64 | 84 | 104 | 124 | 164 | 184 | 204 | 224 | 63 | 73 | 83 | 93 | 103 | 113 | 123 | 133 |
| | 65 | 85 | 105 | 125 | 165 | 185 | 205 | 225 | 64 | 74 | 84 | 94 | 104 | 114 | 124 | 134 |
| | 66 | 86 | 106 | 126 | 166 | 186 | 206 | 226 | 65 | 75 | 85 | 95 | 105 | 115 | 125 | 135 |
| | 67 | 87 | 107 | 127 | 167 | 187 | 207 | 227 | 66 | 76 | 86 | 96 | 106 | 116 | 126 | 136 |
| | 68 | 88 | 108 | 128 | 168 | 188 | 208 | 228 | 67 | 77 | 87 | 97 | 107 | 117 | 127 | 137 |
| | 69 | 89 | 109 | 129 | 169 | 189 | 209 | 229 | 68 | 78 | 88 | 98 | 108 | 118 | 128 | 138 |
| | 70 | 90 | 110 | 130 | 170 | 190 | 210 | 230 | 69 | 79 | 89 | 99 | 109 | 119 | 129 | 139 |
| | 71 | 91 | 111 | 131 | 171 | 191 | 211 | 231 | 70 | 80 | 90 | 100 | 110 | 120 | 130 | 140 |
| | 72 | 92 | 112 | 132 | 172 | 192 | 212 | 232 | 71 | 81 | 91 | 101 | 111 | 121 | 131 | 141 |
| | 73 | 93 | 113 | 133 | 173 | 193 | 213 | 233 | 72 | 82 | 92 | 102 | 112 | 122 | 132 | 142 |
| | 74 | 94 | 114 | 134 | 174 | 194 | 214 | 234 | 73 | 83 | | | | | | |

TEKTRONIX INSTRUMENTATION SOFTWARE LIBRARY

Utility Software for TM 5000 Instruments

Utility Software is available from Tektronix, Inc. for TM 5000 Instruments. This software consists of a set of subroutines and subprograms that perform common instrument functions over the GPIB such as data acquisition, front-panel set-up, etc. These routines are designed to be easily integrated into your application programs. And since they are small and well documented, the routines are easy to modify to suit your particular applications. Refer to the current Tektronix Instrumentation Software Library Catalog for instrument options, ROM packs, and other required equipment.

The following Utility Software was available when this Instrument Interfacing Guide was printed. Other software may be available; contact your local Tektronix Field Office for further information.

| Description | Tektronix Part No. |
|---|--------------------|
| TM 5000/4041 Utility Software (DC-100 tape) | 062-6958-01 |
| TM 5000/4052A Utility Software (DC-300 tape) | 062-6957-01 |

Ordering Utility Software (U.S. Only)

Your local Tektronix Field Office has the current prices for software available from the Tektronix Instrumentation Software Library.

Order Tektronix Instrumentation Software Library programs from Tektronix Central Parts Ordering by using the toll-free number serving your area. The following map identifies the geographical regions in the U.S. and the toll-free number serving each region.

Call the toll-free number serving your area and give the Customer Service Representative the Tektronix nine-digit part number and name of the software package you want to order. If you have any questions about the software, call your local Tektronix Field Office.

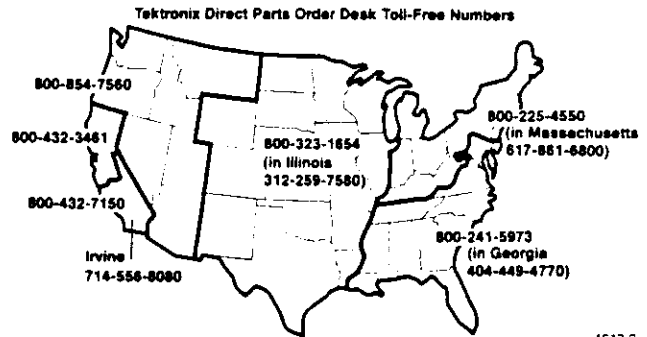

Ordering Utility Software (Outside the U.S.)

Outside of the U.S., order Tektronix Instrumentation Software Library programs through your local Tektronix sales office or from the Tektronix Instrumentation Software Library order point serving your area. Refer to the following list for the applicable library order point.

Africa, Europe, Middle East

Contact local Tektronix sales office.

Australia

Tektronix Instrumentation Software Library
Tektronix Australia Pty. Limited
Sydney
80 Waterloo Road
North Ryde, N.S.W. 2113

Canada

Tektronix Instrumentation Software Library
Tektronix Canada Ltd.
P.O. Box 6500
Barrie, Ontario
Canada L4M 4V3

Caribbean, Latin America, and Far East (except Japan)

Tektronix Instrumentation Software Library
Export Marketing
Tektronix, Inc.
P.O. Box 500
Beaverton, OR 97077
U.S.A.

Japan

Tektronix Instrumentation Software Library
Sony/Tektronix Corporation
9-31 Kitashinagawa-5
Tokyo 141 Japan

Tektronix Instrumentation Software Library
Tektronix, Inc.
Group 157, 54-016
P.O. Box 500
Beaverton, OR 97077

Program Library

The Tektronix Instrumentation Software Library includes over 200 software programs for a variety of Tektronix programmable instruments and controllers. The Library Catalog provides abstracts of the available software. Programs are available as ready-to-load media or as listings (see Catalog). For a copy of the latest catalog, contact your local Tektronix Field Office or representative and ask for Tektronix Instrumentation Software Library Catalog #99W-5293.

Program Contributions

If you have a program which you would like to submit to the Tektronix Instrumentation Software Library, we will send you, in exchange, one software package of your choice from the Customer/User Software portion of the Program Library (see current library catalog). Submitted programs must use Tektronix programmable instruments and must meet certain coding and documentation standards.

To contribute a program, submit a copy of the program on media along with a listing and a Tektronix Instrument Software Library release form (see current library catalog). If the program was created as part of your employment, the release must be signed by an authorized representative of your employer. Acceptance of the program is subject to review of the Tektronix Instrumentation Software Library staff.

For further information on submitting a program or for information about coding and documentation standards, contact:

Software Warranty

Tektronix warrants that the media (tapes, disks, ROMs, etc.) on which Software Products are furnished and the encoding of the programs on the media will be free from defects in materials and workmanship for a period of three (3) months from the date of shipment. If any such medium or encoding proves defective during the warranty period, Tektronix will provide a replacement in exchange for the defective medium. Except as to the media on which Software Products are furnished, Software Products are provided "as is" without warranty of any kind, either expressed or implied. Tektronix does not warrant that the functions contained in the programs will meet Customer's requirements or that the operations of the programs will be uninterrupted or error-free.

In order to obtain service under this warranty, Customer must notify Tektronix of the defect before the expiration of the warranty period. If Tektronix is unable to provide a replacement that is free from defects in materials and workmanship within a reasonable time thereafter, Customer may terminate the license for the Software Product and return the Software Product with the associated materials for credit or refund.

Tektronix disclaims any implied warranties of merchantability or fitness for a particular purpose. Tektronix' responsibility to replace defective media or refund customer's payment is the sole and exclusive remedy provided to the customer for breach of this warranty. Tektronix will not be liable for any indirect, special, incidental, or consequential damages irrespective of whether Tektronix has advance notice of the possibility of such damages.

INSTRUCTIONS D'UTILISATION

Introduction

Ce chapitre fournit des indications sur l'installation et le retrait du DM 5010 dans un châssis d'alimentation de la série TM 5000 et décrit les fonctions des commandes et connecteurs de la face avant. Le paragraphe Familiarisation est destiné à faciliter l'utilisation de l'appareil en mode Local (commande manuelle), celui-ci n'étant pas connecté au Bus Interface Général GPIB via le module d'alimentation.

Des informations détaillées sur la programmation du DM 5010 par l'intermédiaire du Bus GPIB sont données au chapitre Programmation.

PREPARATION

Installation et retrait de l'appareil

ATTENTION

A la livraison, le DM 5010 doit être mis sous tension durant 24 heures environ, de façon à ce que sa batterie interne soit suffisamment chargée. Sinon, il pourrait en résulter un fonctionnement défectueux de l'appareil, dû à la perte des facteurs d'étalonnage mémorisés. Pour rappeler de la mémoire ces facteurs d'étalonnage, se référer à la Procédure de Réglage de ce manuel.

NOTE

Le DM 5010 est conçu pour être utilisé dans un Module d'Alimentation de la Série TM 5000. Se référer au manuel d'utilisation du module d'alimentation avant de procéder à l'installation du DM 5010.

Le DM 5010 est étalonné et prêt à l'emploi dès la livraison. S'assurer que le sélecteur de tension réseau du module d'alimentation est correctement positionné. De plus, le DM 5010 contient un cavalier interne de sélection de fréquence réseau. Pour une meilleure réjection du bruit associé à la fréquence du réseau en mode Vitesse de Conversion Rapide (FAST CONVERSION RATE), la position de ce cavalier doit correspondre à la fréquence du réseau. A la livraison, ce

cavalier est positionné sur 60 Hz. Des informations supplémentaires sont données au chapitre Maintenance de ce manuel.

ATTENTION

En vue de prévenir toute détérioration de cet instrument, couper l'alimentation du module d'alimentation avant l'installation ou le retrait de tout tiroir. Installer et ôter le tiroir avec précaution.

Veiller à ce que les détrompeurs (du connecteur du compartiment sélectionné du module d'alimentation) coïncident avec les encoches du connecteur du tiroir. Si ce n'est pas le cas, ne pas installer le DM 5010 avant d'en découvrir la raison. Une fois cette condition satisfaite, aligner les rainures supérieures et inférieures du tiroir avec les guides du compartiment sélectionné (voir Fig. 2.1). Insérer le Multimètre dans le châssis et le pousser à fond pour que le circuit imprimé se place correctement. Mettre le module en marche (commutateur POWER).

Pour extraire le multimètre du module d'alimentation, couper l'alimentation (commutateur POWER), tirer le bouton de déverrouillage (coin gauche à l'avant du tiroir). Tirer l'instrument hors du compartiment en le maintenant dans la position horizontale.

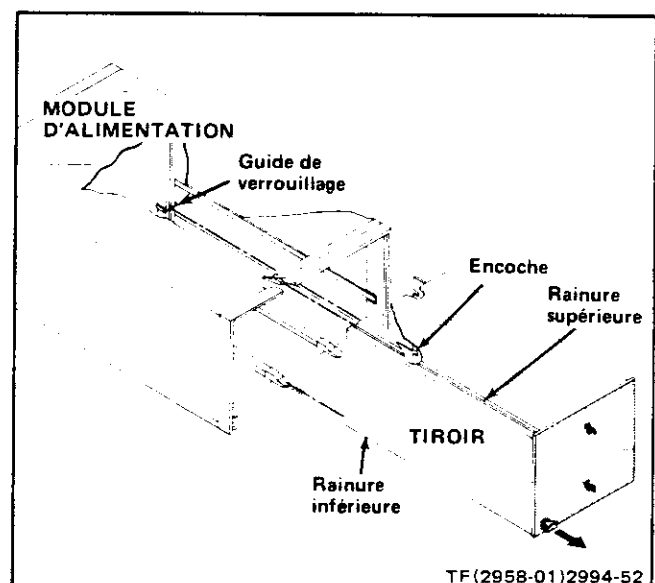

Fig. 2.1. Installation et retrait du tiroir.

COMMANDES ET CONNECTEURS DE LA FACE AVANT

Informations générales

Les 17 boutons poussoirs de la face avant indiqués ci-dessous correspondent chacun à une fonction de l'instrument. Ils s'allument une fois enfoncés. Les boutons de la colonne de gauche s'annulent respectivement : un seul bouton est allumé à la fois. Les boutons de la colonne de droite restent allumés jusqu'à ce qu'on les enfonce de nouveau.

| | |
|------------|-------------------|
| DCV | NULL |
| OHMS | LOW FREQ RESPONSE |
| DIODE TEST | AUTO |
| ACV | RUN |
| ACV + DCV | TRIGGERED |
| | FAST |
| | AVERAGE |
| | X-B |
| | A |
| | dBm |
| | dBr |
| | COMPARE |
| | REAR INPUT |

Les boutons poussoirs restants (23) ne s'allument pas. Voir figure 2.2.

Fenêtre d'affichage

La partie gauche de la fenêtre contient les mesures et les résultats des calculs affichés sur 4 chiffres et demi (DELs). Les zéros à gauche du point décimal sont supprimés. Un clignotement indique un dépassement de gamme au cours d'une mesure de tension. "OC" est affiché pour les fonctions OHMS et DIODE TEST.

La partie centrale indique la gamme de mesure sélectionnée. Une DEL allumée en vis-à-vis de l'un des mots MILLI, KILO et MEGA indique l'unité de mesure affichée en milli, kilo, ou mega. Le point décimal est fixe à l'intérieur d'une même gamme de mesure. La DEL et l'emplacement du point décimal indiquent la gamme sélectionnée en modes Sélection Automatique (AUTO) et Sélection Manuelle (par incréments - STEP). Voir figure 2.2.

La partie droite de la fenêtre d'affichage indique le mode d'utilisation de l'instrument, à savoir :

REMOTE et ADDRESSED s'allument lorsque l'instrument fonctionne sous contrôle de programme à distance via le Bus GPIB.

ERROR s'allume pour une erreur interne, une erreur décelée au cours d'un auto-test, ou une erreur d'utilisation. La partie gauche de la fenêtre affiche également les codes d'erreurs indiquant le type d'erreur. Se référer au tableau 2.2 du paragraphe Familiarisation de ce même chapitre.

| Fonction | Multiplicateur éclairé | Gamme sélectionnée | | | |
|------------------|------------------------|-------------------------------|-------|--------|--------|
| | | | | | |
| DCV | • MILLI | | | 200 mV | |
| | | 2 V | 20 V | 200 V | 1000 V |
| ACV et ACV + DCV | • MILLI | | | 200 mV | |
| | | 2 V | 20 V | 200 V | 700 V |
| OHMS | | | | 200 Ω | |
| | • KILO | 2 kΩ | 20 kΩ | 200 kΩ | |
| | • MEGA | 2 MΩ | 20 MΩ | | |
| DIODE TEST | | Utilise la gamme 2 V continus | | | |

| | | | | | | | | |
|---|---|---|---|---|---|---|---|---|
| 1 | ↑ | 9 | ↑ | 9 | ↑ | 9 | ↑ | 9 |
|---|---|---|---|---|---|---|---|---|

Indication "hors-gamme" :
 Clignotement pour les mesures de tension
 "OC" affiché pour les fonctions OHMS et DIODE TEST

Noir quand la commande FAST CONVERSION RATE est inhibée

TF2994-02

Fig. 2.2. Indications des gammes de mesure.

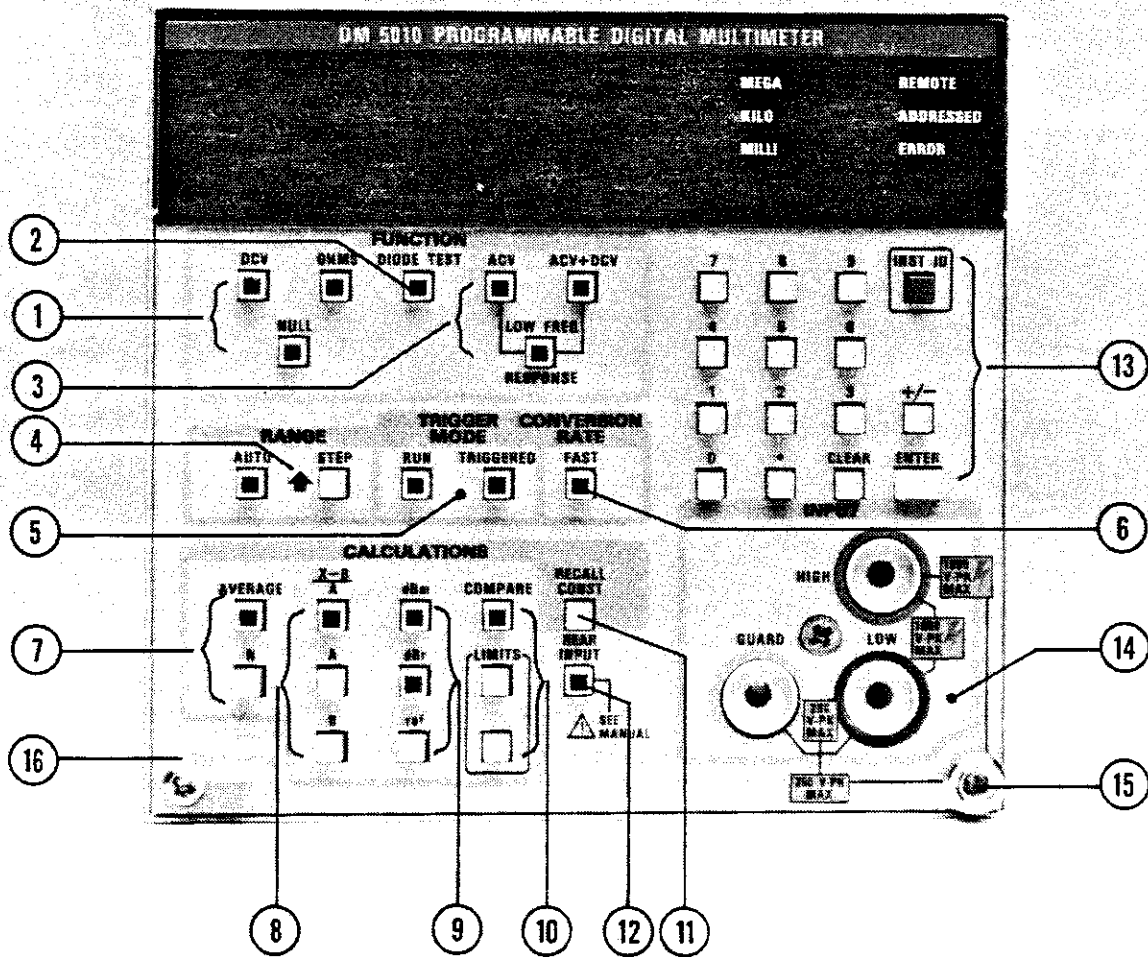

Fig. 2.3. Commandes et connecteurs de la face avant du DM 5010.

2994-03

Instructions d'utilisation - DM 5010

Commandes et connecteurs

La liste suivante décrit les commandes et connecteurs de la face avant du DM 5010. Voir figure 2.3.

FONCTIONS

1

DCV

Bouton allumé - le DM 5010 mesure les tensions continues appliquées aux connecteurs de la face avant ou de l'interface arrière. Les gammes de mesure utilisées avec cette fonction sont : 200 mV, 2V, 20V, 200V, et 1000V.

OHMS

Bouton allumé - Sélectionne le mode Mesure de Résistances. Les résistances appliquées aux connecteurs de la face avant ou de l'interface arrière sont mesurées dans les gammes 200 Ω , 2 K Ω , 20 K Ω , 200 K Ω , 2 M Ω et 20 M Ω .

NULL

Opère en mode DCV (tension continue), OHMS, DIODE TEST, ACV (tension alternative) et ACV + DCV (quelle que soit la gamme sélectionnée). Bouton allumé - mesure et mémorise la valeur de la résistance ou de la tension existant aux bornes des connecteurs de la face avant ou de l'interface arrière. Le décalage mémorisé est appliqué aux mesures suivantes et aux résultats affichés. Cette valeur peut représenter jusqu'à $\pm 100\%$ de la gamme. Lorsqu'on passe à une autre fonction ou que l'on inhibe la fonction NULL (appuyer sur le bouton NULL), ce décalage n'est plus appliqué. La valeur mémorisée est conservée en mémoire jusqu'à un autre décalage (NULL) ou jusqu'à la sélection d'une autre fonction de mesure.

AVERTISSEMENT

En mode NULL, la mesure affichée peut ne pas indiquer la valeur de la tension appliquée aux connecteurs d'entrée.

2

DIODE TEST

Bouton allumé - génère un courant continu de 1 mA, disponible sur le connecteur HIGH de la face avant ou de l'interface arrière. Celui-ci passe normalement du connecteur HIGH au connecteur LOW via un composant connecté entre les deux. La tension développée à travers ce composant est mesurée et affichée (gamme 2V continu).

3

ACV

Bouton allumé - Le DM 5010 mesure et affiche des tensions alternatives efficaces vraies. Les tensions appliquées sont couplées intérieurement (couplage alternatif) au convertisseur de tension efficace. Les gammes utilisées sont : 200 mV, 2 V, 20 V, 200 V et 700 V.

ACV + DCV

Bouton allumé - Le DM 5010 mesure et affiche des tensions alternatives vraies élevées à un niveau de tension continu. Les tensions appliquées sont couplées intérieurement (couplage continu) au convertisseur de tension efficace. Les gammes utilisées sont : 200 mV, 2 V, 20 V, 200 V et 700 V.

LOW FREQ RESPONSE

Bouton allumé et en mode ACV ou ACV + DCV - L'instrument moyenne quatre mesures et affiche la valeur moyenne de ces mesures, puis répète cette séquence d'opérations. Cette fonction permet d'effectuer des mesures stables de tensions alternatives basse fréquence. La limite de fréquence spécifiée est 10 Hz. Toutefois, cette fonction est utilisable sur toute la plage de fréquences du DM 5010.

GAMME

4

AUTO

Bouton allumé - La sélection de gamme est automatique. A la limite supérieure d'une gamme, le DM 5010 sélectionne automatiquement la gamme supérieure. Si la valeur mesurée est inférieure à 9,5 % de la gamme (pour la plupart des gammes), le DM 5010 sélectionne la gamme inférieure.

STEP

Incrémente d'une gamme de mesure ; cette gamme est maintenue jusqu'à ce qu'on appuie sur la touche AUTO (Sélection de Gammes Automatique) ou de nouveau sur la touche STEP. Elle ne varie pas si l'on sélectionne une autre fonction de mesure (DCV, OHMS, DIODE TEST, ACV, ACV + DCV), sauf si la commutation dans la fonction OHMS fait passer dans la gamme maximale. Une incrémentation de la gamme maximale fait passer dans la gamme minimale.

MODE DE DECLENCHEMENT

5

RUN

Bouton allumé - Les conversions sont déclenchées librement à la vitesse sélectionnée. Pour la sélection de la Vitesse de Conversion, se référer à FAST.

TRIGGERED

Bouton allumé - Déclenche et affiche une mesure. Une nouvelle pression sur ce bouton déclenche la mesure suivante (ou la réception du signal de déclenchement EXTRIG). L'utilisation du signal EXTRIG nécessite l'installation d'un cavalier interne par un personnel de maintenance qualifié. Le bouton TRIGGERED clignote rapidement lors d'un déclenchement correct.

PLAGE DE CONVERSION

6 FAST
 Bouton allumé - La vitesse de conversion (affichée) est la vitesse maximale spécifiée pour la fonction de mesure sélectionnée. La résolution pour cette vitesse de conversion est 3,5 chiffres.
 Non allumé - La conversion a lieu à la vitesse normale spécifiée pour la fonction de mesure sélectionnée. Les résultats sont affichés sur 4,5 chiffres.

7 AVERAGE
 Bouton allumé - Le DM 5010 calcule la moyenne d'une série de mesures. La valeur de la constante N détermine le nombre de mesures moyennées. Pour calculer la moyenne, l'instrument accumule les valeurs mesurées et divise la somme par le nombre de moyennes effectuées. Si l'on se trouve également en mode LOW FREQ RESPONSE (Réponse en Basse Fréquence), le nombre de mesures moyennées est quatre fois supérieur à la valeur de la constante N. En mode TRIGGERED, un seul déclenchement est nécessaire pour initialiser toutes les mesures utilisées dans le calcul de la Moyenne.

N
 Ce bouton est utilisé pour mémoriser une constante ou rappeler une constante utilisée précédemment pour le calcul de la Moyenne (AVERAGE). Cette constante détermine le nombre de mesures moyennées. A la mise en service, la valeur de N est 2. On peut lui substituer tout nombre entier positif entre ≥ 1 et ≤ 19999 .

8 X-B/A
 Bouton allumé - Le DM 5010 soustrait d'une mesure une constante de décalage mémorisée, divise le résultat par une constante Facteur d'échelle mémorisée, et affiche le résultat. La constante Décalage est B, la constante Facteur d'échelle est A et la mesure est X.

A,B
 Ces boutons sont utilisés pour mémoriser ou rappeler les constantes utilisées dans le calcul de X-B/A. A la mise en service, la valeur de A est 1, la valeur de B est 0. Il est possible de substituer n'importe quel nombre à ces constantes (entier, décimal, positif ou négatif), excepté la valeur 0 pour A.

9 dBm
 Bouton allumé - Le DM 5010 calcule et affiche le rapport de deux puissances. La référence est 1 mW dans une résistance de 600 Ω .
 En appliquant la formule :

$$dBm = 20 \log_{10} \left| \frac{x_1}{\sqrt{.6}} \right|$$

X₁ étant la mesure de tension. Le logarithme de la valeur absolue de X₁/ $\sqrt{0,6}$ est calculé.

dBr
 Bouton allumé - Le DM 5010 calcule et affiche le rapport logarithmique d'une mesure sur la constante de référence mémorisée (bouton ref), en utilisant la formule :

$$dBr = 20 \log_{10} \left| \frac{x_1}{ref} \right|$$

X₁ étant la mesure. Le logarithme de la valeur absolue de X₁/ref est calculé.

ref
 Ce bouton est utilisé pour mémoriser une constante, ou rappeler une constante utilisée, dans le calcul de dBr. A la mise sous tension, la valeur de ref est 1. Cette valeur peut être tout autre nombre différent de 0.

10 COMPARE
 Bouton allumé - Le DM 5010 compare la mesure suivante avec les limites définies par les constantes LIMITS. Si la mesure comparée est : - algébriquement inférieure aux deux constantes, le mot LO est affiché ; - algébriquement supérieure aux deux constantes, le mot HI est affiché ; - égale à l'une des constantes ou comprise entre les deux constantes, le mot PASS est affiché.

LIMITS (2)
 Boutons utilisés pour mémoriser ou rappeler les constantes utilisées comme limites dans le calcul de la comparaison (COMPARE). Les valeurs des constantes sont égales à 0 à la mise en service.

11 RECALL CONST
 Une pression sur ce bouton, puis sur l'un des boutons d'entrée/rappel d'une constante (N, A, B, ref, LIMITS) provoque l'affichage de la constante mémorisée correspondante.

12 REAR INPUT 
 Voir au paragraphe Familiarisation de ce manuel les mesures via l'interface arrière. Bouton allumé - Sélectionne les entrées sur l'interface arrière au lieu des entrées en face avant.

13 Chiffres (0 à 9), point décimal et signe.
 Ces boutons sont utilisés pour entrer les valeurs numériques, décimales et la polarité des constantes.

CLEAR
 Lorsqu'un code d'erreur est affiché (dans la fenêtre d'affichage), une pression sur ce bouton efface ce code d'erreur. Lors de l'entrée d'une constante, efface la valeur d'une constante non encore entrée (par la touche ENTER).

ENTER
 Lors de l'entrée d'une constante, mémorise cette constante et affiche la valeur mémorisée.

Instructions d'utilisation - DM 5010

INST ID

Provoque l'affichage de l'adresse primaire de l'instrument et, si la commande Requête de l'Utilisateur (USEREQ) a été validée, génère une Demande de Service (SRQ) sur le Bus GPIB. Le signe "moins" est éclairé en mode Emetteur Seulement et le point décimal droit s'allume si la fin de message sélectionnée est LF/EOI (et non EOI ONLY).

ENTREES

14

Connecteur HIGH

Entrée analogique flottante haute utilisée avec les connecteurs LOW et GUARD pour toutes les mesures en face avant.

Connecteur LOW

Entrée analogique flottante basse utilisée avec le connecteur HIGH.

Connecteur GUARD

Entrée isolée reliée à un écran entourant le circuit analogique de l'instrument. Utilisé avec un conducteur de garde (GUARD), cette entrée est normalement connectée au conducteur de test LOW par l'utilisateur au point de mesure. Sinon, le connecteur GUARD est relié au connecteur LOW par un contact interne monté dans le connecteur. Ce connecteur permet d'augmenter la réjection en mode Commun.

15

Connecteur à la masse du châssis.

16

Tirette de déverrouillage. Tirer pour ôter le tiroir.

FAMILIARISATION

Voici une description des commandes et connecteurs de la face avant du DM 5010 utilisés en mode Local.

Auto-test à la mise en service

A la mise en service, le DM 5010 exécute un programme d'auto-test. Durant l'auto-test, toutes les DELs de la face avant sont allumées. Après l'auto-test,

l'instrument passe à l'état Local (LOCS) ; les réglages (par défaut) à la mise en service sont indiqués au tableau 2.1.

Tableau 2.1
Réglages à la mise en service
(Fonctions en face avant seulement)

| Commandes en face avant | Etat |
|-------------------------|------------------------|
| DCV | Enfoncée |
| OHMS | Sortie |
| NULL | (Sortie) Constante = 0 |
| DIODE TEST | Sortie |
| ACV | Sortie |
| ACV+DCV | Sortie |
| LOW FREQ RESPONSE | Sortie |
| AUTO | Enfoncée |
| STEP | Sortie |
| RUN | Enfoncée |
| TRIGGERED | Sortie |
| FAST | Sortie |
| AVERAGE | Sortie |
| N | Constante = 2 |
| <u>X-B</u> | |
| A | Sortie |
| A | Constante = 0 |
| B | Constante = 1 |
| dBm | Sortie |
| dBr | Sortie |
| ref | Constante = 1 |
| COMPARE | Sortie |
| LIMITS | Constantes = 0,0 |
| REAR INPUT | Sortie |

En cas de détection d'une erreur interne durant l'auto-test, l'instrument affiche continuellement un code d'erreur sur 3 chiffres dans la fenêtre d'affichage et l'indicateur ERROR est éclairé. Voir tableau 2.2. Pour découvrir l'origine d'une erreur, s'adresser à un personnel de maintenance qualifié.

Tableau 2.2
CODES D'ERREURS AFFICHES EN FACE AVANT

| Code affiché | Condition anormale |
|--------------|--|
| | Erreurs d'exécution : |
| 205 | Argument hors-gamme |
| 231 | L'instrument n'est pas en position étalonnée |
| 232 | Hors des limites étalonnées |
| | Erreurs internes : |
| 303 | Erreur dans le bloc mathématique |
| 311 | Temps de conversion erroné |
| 317 | Temps de réponse en face avant erroné |
| 318 | Constante d'étalonnage erronée |
| 340 | RAM erronée |
| 341 | RAM erronée |
| 351 | Checksum d'étalonnage erronée |
| 372 | ROM C000 mal positionnée |
| 373 | ROM D000 mal positionnée |
| 374 | ROM E000 mal positionnée |
| 392 | Checksum de la ROM C000 erroné |
| 393 | Checksum de la ROM D000 erroné |
| 394 | Checksum de la ROM E000 erroné |
| 395 | Checksum de la ROM F000 erroné |

Instructions générales d'utilisation

Laisser l'instrument chauffer 30 minutes, pour obtenir la précision spécifiée. Dans les fonctions OHMS et DIODE TEST, un dépassement de gamme provoque l'affichage de "OC". Dans les fonctions DCV, ACV et ACV + DCV, un dépassement de gamme est indiqué par un affichage clignotant.

ATTENTION

Veiller à ne pas dépasser la tension d'entrée maximale.

Pour toutes les fonctions de mesure, la sélection de gammes peut être automatique (AUTO) ou manuelle (STEP). Voir au paragraphe Fenêtre d'affichage l'indication de la gamme utilisée. La fonction DIODE TEST n'utilise que la gamme 2V.

ATTENTION

En mode Sélection de Gamme Automatique, ne pas passer de manière répétitive d'une tension basse (< 200 mV crête) à une tension haute (> 200 V crête). Dans le cas d'alternances répétées de tensions extrêmes, utiliser la commande STEP pour sélectionner la gamme supérieure appropriée avant d'augmenter la tension d'entrée. Le risque est d'obtenir des mesures temporaires erronées en utilisant la gamme 200 mV.

Connexions d'entrée

Les bornes HIGH, LOW et GUARD sont utilisées pour les mesures en face avant. Un contact interne (dans la borne GUARD) relie les bornes LOW et GUARD. Ce contact est fermé jusqu'à ce qu'un cordon de mesure soit inséré dans la borne GUARD. Il reste ouvert jusqu'au retrait de ce cordon.

La figure 2.4 illustre trois exemples d'utilisation des connecteurs de la face avant. La méthode la plus couramment utilisée est la méthode A lorsqu'on néglige la tension de mode commun. Dans cet exemple, seules les bornes LOW et HIGH du DM 5010 sont utilisées. Aucun cordon n'étant inséré dans la borne GUARD, le contact interne (dans la borne) est fermé et relie les bornes LOW et GUARD. Ceci entraîne le passage du courant de mode commun à travers le cordon LOW et la masse de la source d'alimentation, provoquant une erreur de mesure.

La méthode B permet d'obtenir une précision optimale, lorsqu'on désire éliminer la tension de mode commun. La borne GUARD du DM 5010 est reliée à la borne LO de la source. Le courant de mode commun circule à travers le conducteur de garde (GUARD) et la masse de la source d'alimentation mais non à travers le circuit de mesure (cordon LOW).

Méthode C - La borne GUARD du DM 5010 est reliée à la masse de la source. Ceci peut produire une erreur de mesure, du fait que le courant de mode commun circule dans le circuit de mesure.

AVERTISSEMENT

Pour éliminer tout risque d'électrocution par les tensions mesurées :

1. *Eviter tout contact avec la source de tension, si la tension mesurée dépasse 42,4 V crête.*
2. *Déconnecter les cordons du circuit sous test avant de les débrancher du DM 5010 ou avant d'ôter le DM 5010 du module d'alimentation.*

Mesures sur l'interface arrière



Si le bouton REAR INPUT est enfoncé (allumé), les signaux appliqués aux broches 28B (HI) et 28A (LO) de l'interface arrière sont mesurés. Si ce bouton est sorti (éteint), les signaux mesurés sont ceux appliqués aux bornes de la face avant.

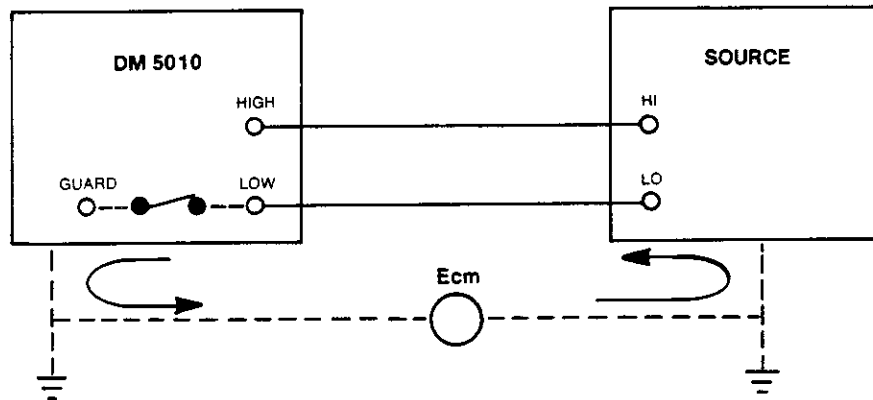

A. Connexion (interne) entre la borne GUARD et la borne LOW du DM 5010. Erreur de mesure due à la tension de mode commun (Emc).

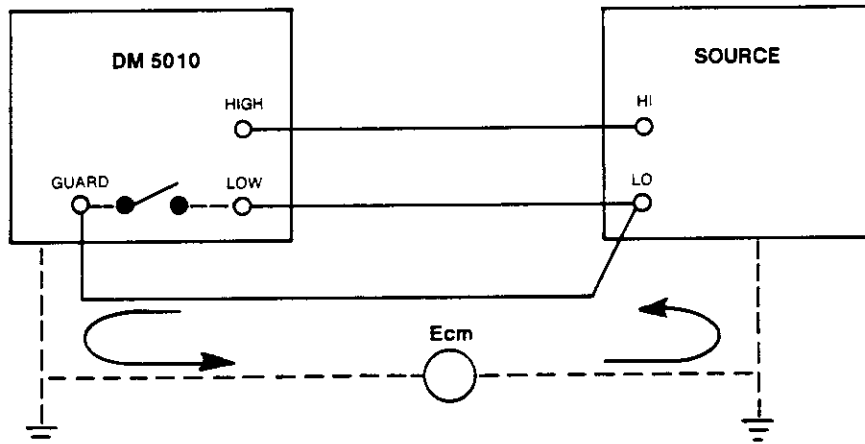

B. Connexion entre la borne GUARD et la borne basse (LO) de la source. Pas d'erreur due à la tension de mode commun.

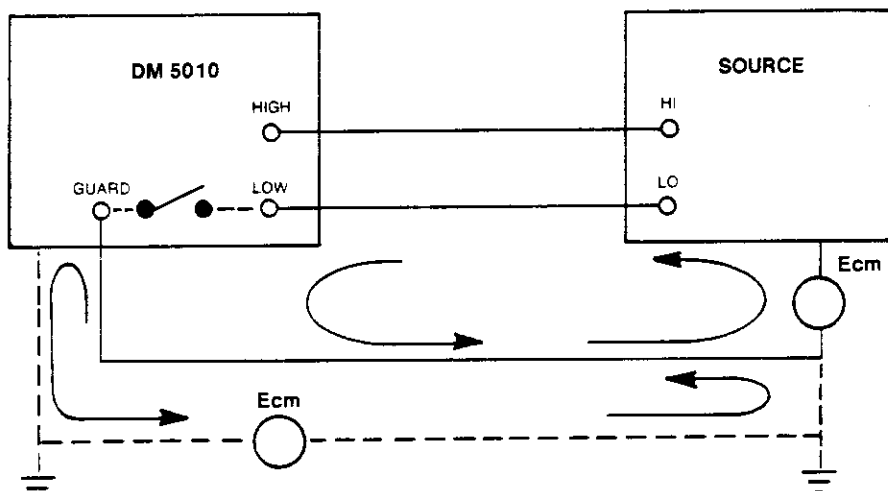

C. Connexion entre la borne GUARD et la masse du châssis d'alimentation. Erreur minimale due à la tension de mode commun, la tension de mode commun se situant au niveau des deux masses.

TF2994-04

Fig. 2.4. Exemples de méthodes de connexion en face avant.

ATTENTION

Pour ne pas endommager l'appareil, ne pas appliquer de tension supérieure à 42,4 V alternatifs crête ou à 60 V continu entre les broches 28B (HI) et 28A (LO) du connecteur de l'interface arrière P1031 de la carte ADC (A17).

ATTENTION

Si une tension supérieure à 500 V crête est appliquée sur les bornes de la face avant, ne pas valider les entrées de l'interface arrière, pour éviter tout risque de détérioration de l'instrument ou de fonctionnement erroné.

Mesures de tensions continues

Une pression sur le bouton DCV valide des mesures de tensions continues dans les gammes : 200 mV, 2 V, 20 V, 200 V et 1000 V. Lorsque l'entrée HIGH est positive par rapport à l'entrée LOW, le signe "+" est affiché. Ne pas dépasser les tensions maximales autorisées en entrée.

Mesures de résistances

Une pression sur le bouton OHMS valide des mesures de résistances dans les gammes : 200 Ω, 2 KΩ, 20 KΩ, 200 KΩ, 2 MΩ et 20 MΩ. Le courant passe normalement de la borne HIGH vers la borne LOW. Les courants et tensions maximaux entre bornes et à pleine échelle (sans dépassement de gamme) sont indiqués au tableau 2.3. La tension maximale (en circuit ouvert) disponible entre la borne HIGH et la borne LOW est inférieure à 5 V.

**Tableau 2.3
TENSIONS DE SOURCE
(FONCTION OHMS)**

| Gamme | Courant typique (0 Ω à la pleine échelle) | Tension max. (pleine échelle) |
|---------|--|----------------------------------|
| 200 Ω | de 1,02 mA à 1 mA | |
| 2 K Ω | de 0,12 mA à 0,1 mA | |
| 20 K Ω | de 9,2 μA à 10 μA | 0,2 V |
| 200 K Ω | de 1,08 μA à 1 μA | |
| 2 M Ω | de 0,12 μA à 0,1 μA | |
| 20 M Ω | de 0,12 μA à 0,04 μA | 0,8 V |

Mesure de diodes

Une pression sur le bouton DIODE TEST valide la génération d'un courant de 1 mA continu sur la borne HIGH. La variation de tension aux jonctions de la diode

se mesure en connectant l'anode de la diode à la borne HIGH et la cathode à la borne LOW. Les diodes doivent, pour être testées, présenter une variation de tension inférieure à 1,999 volt. C'est le cas de la plupart des diodes et DELs.

Pour tester la tension inverse, inverser les connexions. "OC" doit apparaître dans la fenêtre d'affichage.

Mesures de tensions alternatives

Il existe deux fonctions de mesure de tensions alternatives :

1. Mesure de tensions alternatives efficaces vraies (ACV)
2. Mesure de tensions alternatives efficaces vraies superposées à un niveau continu (ACV + DCV).

Les gammes de mesure pour ces deux fonctions sont 200 mV, 2 V, 20 V, 200 V et 700 V. Les tensions peuvent être mesurées avec un facteur de crête maximal de 4 pour la pleine échelle. Le facteur de crête est le rapport tension crête sur tension efficace. Veiller à ne pas dépasser la tension maximale autorisée en entrée. La fonction LOW FREQ RESPONSE permet d'effectuer des mesures stables de tensions alternative en basse fréquence. Cette fonction effectue la moyenne de 4 mesures de tensions alternatives.

Vitesses de conversion

Le DM 5010 utilise deux vitesses de conversion. La vitesse FAST (bouton CONVERSION RATE allumé) permet d'effectuer des mesures à la vitesse maximale spécifiée pour la fonction sélectionnée. La résolution de l'affichage est de 3,5 chiffres. Lorsque le bouton CONVERSION RATE est éteint, les mesures sont effectuées à la vitesse normale spécifiée pour la fonction sélectionnée avec une résolution d'affichage de 4,5 chiffres.

Déclenchement

Le DM 5010 possède deux modes de déclenchement, les modes RUN et TRIGGERED. Une pression sur le bouton RUN valide des conversions en mode relaxé à la vitesse de conversion sélectionnée. Une pression sur le bouton TRIGGERED valide une mesure à la fois.

En outre, les conversions peuvent être déclenchées via le connecteur de l'interface arrière, broches 16A et 16B (LO) sur la carte Isolation (A15). Ceci nécessite l'installation d'un cavalier (se référer au chapitre Maintenance). L'installation de ce cavalier valide la fonction de déclenchement EXTRIG (en plus de RUN et TRIGGERED). Pour utiliser cette fonction, appuyer sur le bouton TRIGGER pour mettre fin au déclenchement relaxé. La fonction EXTRIG nécessite un signal de déclenchement interne compatible TTL, flanc négatif. Pour un déclenchement unique, cette ligne doit être maintenue à l'état bas pendant 0,5 μs (10 μs max.). Son maintien prolongé à l'état bas provoquerait le déclenchement de plusieurs mesures consécutives.

Instructions d'utilisation - DM 5010

Calculs

Cinq boutons en face avant permettent d'effectuer des calculs sur les mesures effectuées par le DM 5010. Ces calculs peuvent être exécutés individuellement ou séquentiellement. Une séquence de calculs peut être entrée dans n'importe quel ordre (boutons enfoncés). Toutefois, le DM 5010 les exécute dans l'ordre suivant : AVERAGE, X-B/A, dBm ou dBr, COMPARE. L'instrument affiche le résultat de chaque calcul. Les fonctions NULL et LOW FREQ, si elles ont été validées, sont exécutées en priorité. Les calculs dBm et dBr ne peuvent être effectués dans la même séquence. Seule la dernière fonction validée (dBm ou dBr) est exécutée. Un déclenchement démarre l'exécution d'un calcul unique, ou d'une séquence de calculs. En mode RUN (Déclenchement Relâché), tout calcul ou séquence de calculs est répété jusqu'à ce qu'il soit inhibé (bouton correspondant enfoncé de nouveau), ou jusqu'à ce que la sélection d'un autre mode de déclenchement ou d'une autre fonction de mesure soit effectuée. Les DELs d'affichage sont éteintes pendant l'exécution du calcul. L'instrument affiche "OC" pour signaler un dépassement de gamme pour un résultat de calcul.

A l'exception de la fonction dBm, chaque calcul utilise une constante ou plus. La valeur numérique de chaque constante mémorisée prend une valeur par défaut à la mise en service. Cette valeur peut être remplacée par toute autre à l'intérieur des limites spécifiées. Le tableau 2.4 contient la liste de chaque calcul et constante(s)

associée(s), des valeurs par défaut des constantes, et des limites associées à chaque constante.

Modification des valeurs des constantes

Deux méthodes permettent de changer la valeur d'une constante en mémoire.

1. Utilisation du clavier numérique :
 - a. Appuyer sur le bouton de la constante sélectionnée.
 - b. Appuyer sur les touches de clavier numériques pour afficher la nouvelle valeur de la constante (dans les limites spécifiées tableau 2.4).
 - c. Appuyer sur la touche ENTER.
2. Utilisation d'une mesure affichée. (Remplace la valeur d'une constante par la valeur de la mesure affichée). S'assurer que la mesure affichée correspond aux limites spécifiées pour cette constante (tableau 2.4).
 - a. Appuyer sur le bouton de la constante sélectionnée.
 - b. Appuyer sur la touche ENTER.

TABLEAU 2.4
FONCTIONS CALCUL ET CONSTANTES ASSOCIEES

| Calcul | Constante | Valeur par défaut | Plage de constantes valides |
|----------|--|-------------------|--|
| AVERAGE | N | 2 | +1 à +19999 |
| X-B A | B (décalage) A (facteur d'échelle) | 0 1 | nombre entier ou décimal, + ou -, nombre entier ou décimal, $\neq 0$, + ou - |
| dBm | | | |
| dBr | ref | 1 | nombre entier ou décimal, $\neq 0$, + ou - |
| COMPARE | LIMITS (2) | 0 | |

Instructions d'utilisation - DM 5010

Après toute pression sur la touche ENTER, le DM 5010 affiche la valeur de la constante mémorisée. Toute nouvelle valeur valide est affichée. Sinon, la valeur affichée est la valeur précédemment entrée. Chaque valeur d'une constante est conservée en mémoire jusqu'à l'entrée d'une nouvelle valeur, ou jusqu'à ce que l'alimentation du DM 5010 soit coupée.

Exemples de calculs

Voici quelques exemples d'application des fonctions de calcul du DM 5010.

Exemple 1 : Utilisation de la fonction X-B/A pour afficher la différence entre la tension nominale et la tension Zener mesurée.

Régler les commandes en face avant de la façon suivante :

| | |
|-------------------|----------------------|
| DCV | enfoncee |
| NULL | sortie |
| LOW FREQ RESPONSE | sortie |
| RANGE | sur la position AUTO |
| TRIGGER MODE | sur la position RUN |
| CONVERSION RATE | commande FAST |
| | |
| CALCULATIONS | |
| X-B | |
| A | enfoncee |
| Toutes les autres | sorties |
| REAR INPUT | sortie |

Entrer "1" pour la constante A.

Entrer "15" pour la constante B (pour une diode Zener de 15V).

Connecter la diode Zener, la résistance et l'alimentation aux entrées du DM 5010, comme indiqué figure 2.5. La valeur de la résistance et de l'alimentation déterminent le courant Zener.

La tension affichée est instable jusqu'à ce que le courant traversant la diode prenne sa valeur finale. Lorsque l'affichage devient stable, la tension affichée est la différence entre la tension Zener nominale (15V) et la tension Zener mesurée.

Pour obtenir le pourcentage correspondant à la différence de tension, remplacer la constante A par 0,15, A étant égale à B (0,01).

Exemple 2 : Utilisation de la fonction dBr pour découvrir le point d'un amplificateur audiofréquence -3dB (par rapport à la valeur milieu).

Régler les commandes de la face avant de la façon suivante :

| | |
|-------------------|----------------------|
| ACV | enfoncee |
| NULL | sortie |
| LOW FREQ RESPONSE | sortie |
| RANGE | sur la position AUTO |
| TRIGGER MODE | sur la position RUN |
| CONVERSION RATE | commande FAST |
| | |
| CALCULATIONS | |
| dBr | |
| Toutes les autres | sorties |
| REAR INPUT | sortie |

Entrer "1" pour la constante de référence (ref). Connecter le générateur sinusoïdal, l'amplificateur audiofréquence et le DM 5010 comme indiqué figure 2.6.

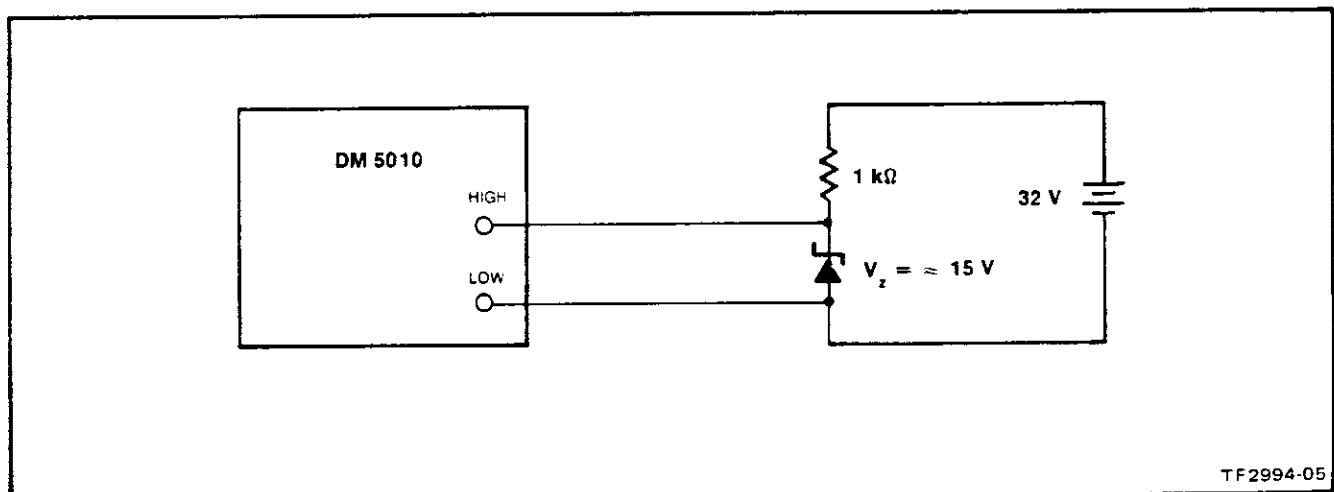

Fig. 2.5. Installation nécessaire au calcul de l'exemple 1

TF2994-05

Instructions d'utilisation - DM 5010

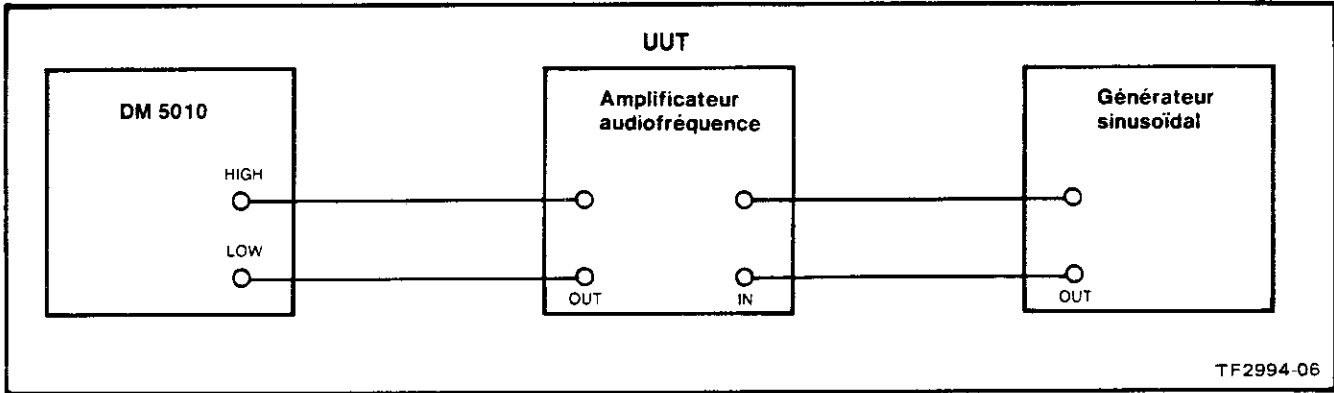

Fig. 2.6. Installation nécessaire au calcul de l'exemple 2.

Régler le générateur sinusoïdal à mi-bande (dans cet exemple 5 KHz) ; régler son amplitude de façon à lire 1 V sur le DM 5010.

Appuyer sur le bouton dBr. La valeur "0.0" est affichée.

Réduire la fréquence du générateur jusqu'à ce que la valeur "-3.00." soit affichée sur le DM 5010 (ne pas retoucher l'amplitude). La fréquence du générateur correspond au point -3dB de l'amplificateur audiofréquence.

Exemple 3 : Utilisation de la fonction COMPARE pour sélectionner des résistances différant de $\pm 2\%$ de la valeur nominale.

Régler les commandes de la face avant du DM 5010 de la façon suivante :

| | |
|-------------------|----------------------|
| OHMS | enfoncée |
| NULL | sortie |
| LOW FREQ RESPONSE | sortie |
| RANGE | sur la position AUTO |
| TRIGGER MODE | sur la position RUN |
| CONVERSION RATE | commande FAST |
| | sortie |
| CALCULATIONS | |
| COMPARE | enfoncée |
| Toutes les autres | sorties |
| REAR INPUT | sortie |

Pour sélectionner des résistances 15 K Ω à $\pm 2\%$ de la valeur nominale, entrer "15300" pour l'une des limites (LIMITS) et "14700" pour l'autre. Connecter la première résistance à trier aux bornes HIGH et LOW du DM 5010. Le DM 5010 affiche "HI" ou "LO" pour indiquer le dépassement de la tolérance 2% ou l'infériorité à cette tolérance. Si la résistance est comprise dans les limites ou égale aux limites, le DM 5010 affiche "PASS".

Les fonctions de calcul COMPARE et X-B/A peuvent être combinées dans l'exemple ci-dessus. Ceci élimine la nécessité d'afficher les valeurs de tolérance. Seule la valeur nominale de la résistance et la tolérance sont utilisées comme constantes.

Entrer "15000" dans B (résistance nominale).

Entrer "150" dans A, A étant égale à B (.01). Ceci convertit la différence entre la valeur nominale et la valeur réelle en "1 %".

Entrer "2" pour une limite (LIMITS) (tolérance de 2%).

Entrer "-2" pour l'autre.

Appuyer sur la touche X-B/A.

Le DM 5010 affiche PASS, HI, ou LO.

Instructions de réemballage

Si le DM 5010 doit être renvoyé à un centre de maintenance Tektronix pour une révision ou une réparation, y apposer une étiquette portant le nom (et l'adresse) de la société utilisatrice et le nom de la personne à y contacter, ainsi que le numéro de série complet de l'instrument et la description du défaut constaté.

Si l'emballage d'origine n'est plus disponible, emballer l'appareil de la façon suivante :

Instructions d'utilisation - DM 5010

Se procurer un carton résistant dont les dimensions internes soient supérieures de 15 cm aux dimensions de l'appareil. La résistance de l'emballage doit être de 90 kg/cm.

Entourer l'instrument d'une feuille de polyéthylène.
Tapisser le fond et les bords de mousse d'urethane sur une épaisseur de 7,5 cm.
Fermer le carton au moyen d'une bande adhésive.

BEDIENUNGSANLEITUNG

Einführung

Dieser Abschnitt des Handbuches gibt Hinweise zum Ein- und Ausbau des Gerätes und beschreibt die Funktionen der Bedienelemente und Anschlüsse auf der Frontplatte des DM 5010. Diese Informationen dienen nur als Hilfe zum Verständnis der manuellen Bedienung des DM 5010. Es wird dabei vorausgesetzt, daß das DM 5010 nicht über die Versorgungseinheit mit dem GPIB verbunden ist.

Vollständige Informationen zur Programmierung des DM 5010 über den GPIB (General Purpose Interface Bus) enthält der Abschnitt „Programmierung“.

VORBEREITENDE ARBEITEN

Ein- und Ausbau

VORSICHT

Nach Erhalt des Gerätes sollte das DM 5010 etwa 24 Stunden lang an das Stromnetz angeschlossen und eingeschaltet werden, um die eingebauten Pufferbatterien aufzuladen. Wird dies nicht gemacht, kann das durch Verlust der im Speicher enthaltenen Kalibrierfaktoren zu fehlerhaftem Betrieb führen. Mit dem in diesem Handbuch enthaltenen „Justierungsvorgang“ können die Kalibrierfaktoren neu in den Speicher eingegeben werden.

ANMERKUNG

Das DM 5010 ist nur für den Betrieb in einer Versorgungseinheit der Serie TM 5000 ausgelegt. Beachten Sie vor dem Einbau des DM 5010 die Bedienungsanleitung der Versorgungseinheit.

Das DM 5010 kommt kalibriert und betriebsbereit zum Versand. Achten Sie darauf, daß der Spannungswahlschalter der Versorgungseinheit richtig eingestellt ist. Das DM 5010 besitzt einen internen Netzfrequenzwähler. Zur bestmöglichen Unterdrückung des Netzfrequenzrauschens sollte bei Betrieb in FAST CONVERSION RATE die richtige Netzfrequenz eingestellt sein. Bei Versand ist das Gerät auf eine Netzfrequenz von 60 Hz

eingestellt. Überlassen Sie die Einstellung der Netzfrequenz dem qualifizierten Servicepersonal.

VORSICHT

Um Beschädigungen zu vermeiden ist vor Einbau des DM 5010 die Spannungsversorgung der Versorgungseinheit abzuschalten. Ein- oder Ausbau dürfen nicht mit Gewalt erfolgen.

Prüfen Sie ob die Plastiksperrern an den Verbindungssteckern der ausgewählten Fächer der Versorgungseinheit mit den Ausschnitten an den Steckerleisten des DM 5010 übereinstimmen. Ist das nicht der Fall, darf das DM 5010 nicht eingebaut werden bevor der Grund dafür festgestellt wurde. Stimmen Sie überein, halten Sie das Chassis des DM 5010 an die oberen und unteren Führungsschienen der gewählten Fächer der Versorgungseinheit und drücken es fest ein, bis die rückseitigen Steckverbindungen einrasten (siehe Bild 2-1). Schalten Sie die Versorgungseinheit ein.

Zum Ausbau des DM 5010 ziehen Sie den Entriegelungshebel (an der unteren linken Ecke) bis die Steckverbindung ausrastet und das Gerät aus der Versorgungseinheit herausgleitet.



Bild 2-1. Ein- und Ausbau.

BEDIENUNGSELEMENTE UND ANSCHLÜSSE AUF DER FRONTPLATTE

Allgemeine Hinweise

Die nachstehend aufgelisteten siebzehn Druckschalter auf der Frontplatte aktivieren nach Eindrücken die jeweilige Funktion und leuchten auf. Die Druckschalter im linken Teil schließen sich gegenseitig aus; d. h. es ist immer nur ein Druckschalter aktiviert (erleuchtet). Die Druckschalter im rechten Teil leuchten auf wenn sie aktiviert werden und bleiben aktiviert und erleuchtet bis sie nochmals gedrückt werden.

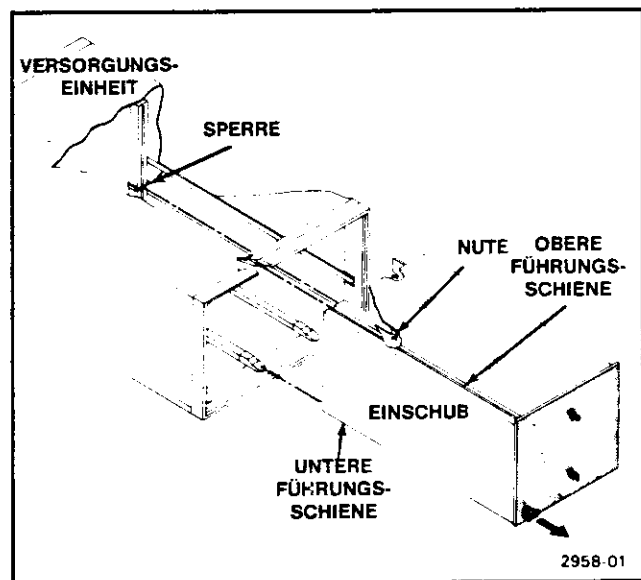
| | |
|------------|-------------------|
| DCV | NULL |
| OHMS | LOW FREQ RESPONSE |
| DIODE TEST | AUTO |
| ACV | RUN |
| ACV + DCV | TRIGGERED |
| | FAST |
| | AVERAGE |
| | X-B |
| | A |
| | dBm |
| | dBr |
| | COMPARE |
| | REAR INPUT |

Anzeigefenster

Im linken Teil der Anzeige werden Meß- und Berechnungsergebnisse durch eine 4 1/2stellige LED angezeigt. Nullen vor Dezimalzahlen werden nicht angezeigt. In den Spannungsmeßfunktionen wird durch Flackern ein Überlaufen angezeigt; für OHMS und DIODE TEST wird OC dargestellt.

Im mittleren Teil der Anzeige werden die Bereichsmultiplikatoren für die dargestellte Anzeige angegeben. Eine den Aufschriften MILLI, KILO und MEGA zugeordnete LED zeigt an, ob es sich bei der dargestellten Messung um Milli-, Kilo- oder Megaeinheiten handelt. Der Dezimalpunkt ist für jeden Funktionsbereich fixiert. Die Multiplikator-LED und die Position des Dezimalpunktes zeigen bei den Bereichswahlmethoden AUTO und manuell (STEP) den Bereich an. Siehe Bild 2-2.

Der rechte Teil des Anzeigefensters zeigt den Betriebszustand des Gerätes wie folgt an:

REMOTE und ADRESSED leuchten nur auf, wenn das Gerät ferngesteuert über den GPIB arbeitet.

ERROR leuchtet auf, wenn ein interner, ein Selbst-Test-, oder ein Betriebsfehler auftritt. Im linken Teil der Anzeige werden auch Fehlercodes dargestellt, welche die Art des Fehlers anzeigen. Siehe Tabelle 2-2 im Abschnitt „Bedienungshinweise“.

| Function | Illuminated Multiplier | Selected Range | | | |
|-------------------|------------------------|--------------------|-------|--------|--------|
| | | | | | |
| DCV | • MILLI | | | 200 mV | |
| | | 2 V | 20 V | 200 V | 1000 V |
| ACV and ACV + DCV | • MILLI | | | 200 mV | |
| | | 2 V | 20 V | 200 V | 700 V |
| OHMS | | | | 200 Ω | |
| | • KILO | 2 kΩ | 20 kΩ | 200 kΩ | |
| | • MEGA | 2 MΩ | 20 MΩ | | |
| DIODE TEST | | Uses 2 V dc range. | | | |

1
↑
9
↑
9
↑
9
↑
9

Overrange indication:
 Display flashes for voltage functions.
 Displays "OC" for OHMS and DIODE TEST functions.

Blank when FAST CONVERSION RATE is enabled. 2994-02

Bild 2-2. DM 5010 Bereichsanzeige auf der Frontplatte.



Bild 2-3. DM 5010 Bedienungselemente und Anschlüsse auf der Frontplatte.

2994-03

Bedienungselemente und Anschlüsse

Nachstehend werden die Bedienungselemente und Anschlüsse auf der Frontplatte des DM 5010 beschrieben. Siehe Bild 2–3.

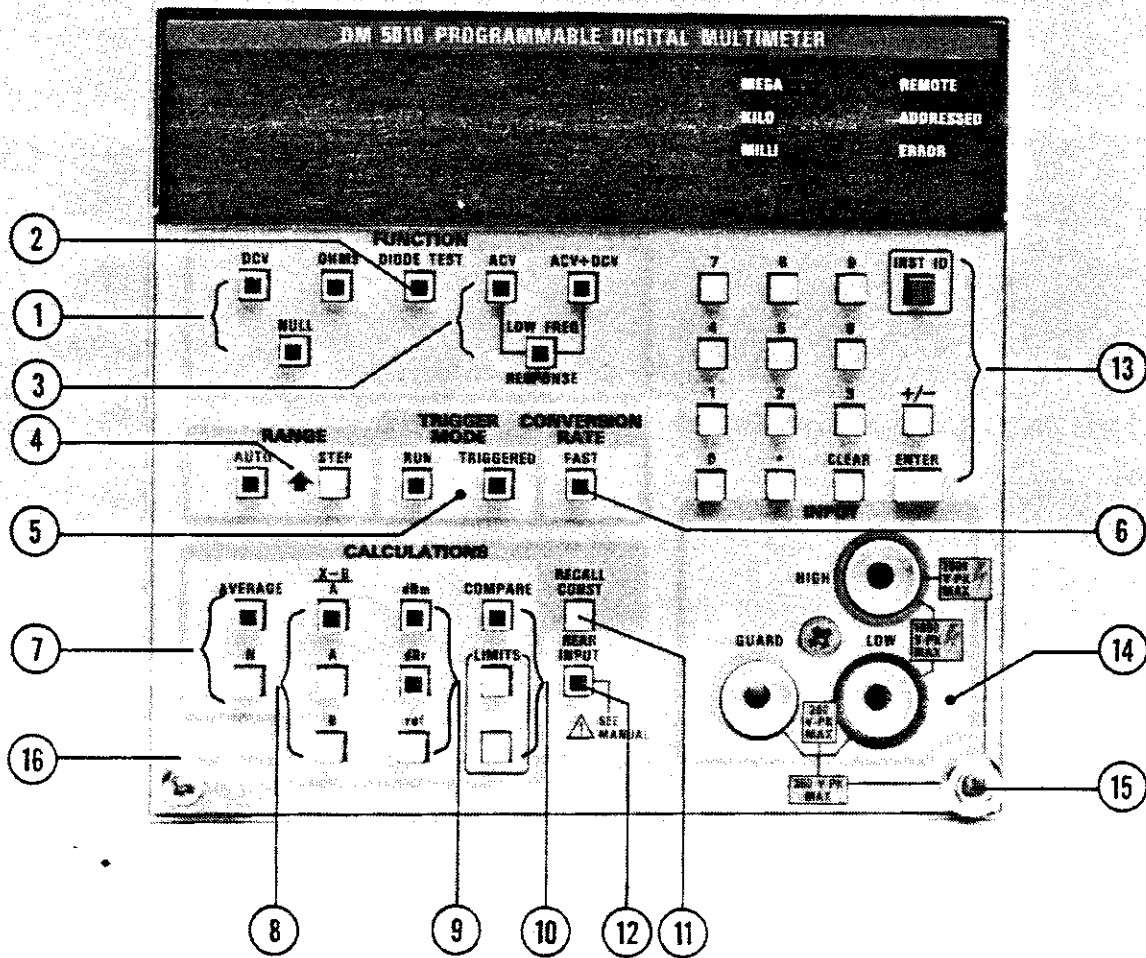
FUNKTIONEN

1 DCV
Wenn diese Drucktaste erleuchtet ist, mißt das DM 5010 die an die Eingangsanschlüsse auf der Frontplatte oder der Rückseite angelegten Gleichspannungen. Die Meßbereiche sind: 200 mV, 2 V, 20 V, 200 V und 1000 V.

OHMS
Diese Drucktaste ist in der Betriebsart Widerstandsmessung erleuchtet. An den Anschluß auf der Frontplatte oder den rückseitigen Schnittstellenanschluß angelegte Widerstände werden in den Bereichen 200 Ω , 2 k Ω , 20 k Ω , 200 k Ω , 2 M Ω und 20 m Ω gemessen.

NULL
Diese Funktion arbeitet, wenn das DM 5010 auf DCV, OHMS, DIODE TEST, ACV + DCV eingestellt ist (in allen Bereichen). Wenn der Tastkopf NULL erleuchtet ist, mißt und speichert das Gerät den an einen der Eingangsanschlüsse angelegten Widerstands- oder Spannungswert. Dieser gespeicherte Offset wird den folgenden Messungen hinzugefügt und die Ergebnisse werden dargestellt. Der Wert des Offset kann bis zu $\pm 100\%$ des Bereichs betragen. Wird die derzeitige Funktion geändert oder die NULL Funktion abgeschaltet (NULL Taste gedrückt), wird der NULL Offset nicht mehr hinzugefügt. Der gespeicherte Offset bleibt erhalten, bis ein neuer Offset durch Nullung eingestellt oder die während der Nullung eingeschaltete Funktion verändert wird.

WARNUNG

Bei eingeschalteter NULL Funktion kann es vorkommen, daß die dargestellte Messung nicht den Wert der an den Eingangsanschlüssen angelegten Spannung anzeigt.

2 DIODE TEST
Wenn diese Taste erleuchtet ist, wird an den positiven Eingangsanschlüssen auf der Frontplatte und der Rückseite ein Gleichstrom von 1 mA erzeugt. Dieser Strom fließt durch ein Bauelement zum negativen Anschluß. Die dabei am Bauelement entstehende Spannung wird im 2 V Gleichspannungsbereich gemessen und dargestellt.

3 ACV
Wenn diese Drucktaste erleuchtet ist, werden vom DM 5010 echte effektive Wechselspannungen gemessen und dargestellt. Die angelegten Span-

nungen werden intern an einen Effektivwandler gekoppelt. Die Meßbereiche sind: 200 mV, 2 V, 20 V, 200 V und 700 V.

ACV + DCV

Ist diese Taste erleuchtet, werden vom DM 5010 echte effektive Wechselspannungen gemessen und dargestellt, die auf einen Gleichspannungspiegel angehoben worden sind. Die angelegten Spannungen werden intern wechselfrequenzmäßig an den Effektivwandler angekoppelt. Die Bereiche sind: 200 mV, 2 V, 20 V, 200 V und 700 V.

LOW FREQ RESPONSE

Wenn diese Drucktaste erleuchtet und die Funktion ACV oder ACV + DCV aktiviert ist, wird aus 4 Messungen der Mittelwert berechnet und dargestellt. Dieser Vorgang wird danach wiederholt. Diese Funktion bietet eine stabile Anzeige bei der Messung von niederfrequenten Wechselspannungen und ist bis 10 Hz spezifiziert. Sie kann jedoch über den gesamten für das DM 5010 spezifizierten Frequenzbereich angewendet werden.

BEREICH

4 AUTO
Wenn diese Taste erleuchtet ist erfolgt die Bereichswahl automatisch. Wird der jeweilige Bereich überschritten, schaltet das DM 5010 in den nächst höheren Bereich um. Beträgt der gemessene Wert weniger als 9,5% des Bereichs, schaltet das Gerät in den nächst niedrigeren Bereich um.

STEP \uparrow

Bei Aktivierung dieser Drucktaste schaltet das DM 5010 in den nächsthöheren Bereich um. Dieser Bereich wird beibehalten, bis für die automatische Bereichswahl die Taste AUTO gedrückt oder der Bereich nochmals erhöht wird. Bei Änderung der Funktion (DCV, OHMS, DIODE TEST, ACV, ACV + DCV) bleibt der Bereich. Nur bei Wahl der Funktion OHMS wird in den höchsten Bereich umgeschaltet. Bei Drücken der Taste während der Arbeit im höchsten Bereich erfolgt Umschaltung in den niedrigsten Bereich.

TRIGGERUNG

5 RUN
Wenn diese Taste erleuchtet ist, läuft die Konversion frei mit der gewählten Rate. Für die Wahl der Wandelrate siehe FAST.

TRIGGERED

Nach Drücken dieser Taste wird eine Messung getriggert und dargestellt. Die nächste Messung beginnt, wenn diese Funktion wieder aktiviert wird (Taste gedrückt, oder ein EXTRIG Triggersignal empfangen wird). Für die Anwendung der EXTRIG Triggerung muß von qualifiziertem Servicepersonal ein interner Anschluß eingebaut werden. Wenn das Gerät getriggert wird, leuchtet die Taste TRIGGERED kurz auf.

WANDELRATE**6 FAST**

Ist diese Taste erleuchtet, entspricht die Wandel- (Meß-) Rate der für die gewählte Meßfunktion spezifizierten maximalen Rate. Bei dieser Wandelrate beträgt die Auflösung 3,5 Stellen.

Wenn die Taste FAST nicht erleuchtet ist, erfolgt die Wandlung mit der für die gewählte Meßfunktion spezifizierten normalen Meßrate. Die Ergebnisse werden 4,5 stellig dargestellt.

7 AVERAGE

Wenn diese Taste erleuchtet ist, berechnet das DM 5010 den Mittelwert aus einer Serie von Messungen. Der Wert der Konstanten N bestimmt aus wie vielen Messungen der Mittelwert gebildet wird. Zur Berechnung des Mittelwertes summiert das Gerät die gemessenen Werte und dividiert die Summe durch die Anzahl der Messungen. Ist LOW FREQ RESPONSE ebenfalls aktiviert, entspricht die Anzahl der Messungen aus denen der Mittelwert gebildet wird dem vierfachen Wert der Konstante N. In der Betriebsart TRIGGERED wird zum Start aller für die AVERAGE Berechnung verwendeten Messungen nur eine Triggerung benötigt.

N

Diese Taste wird zum Speichern oder Abrufen einer bei der AVERAGE Berechnung verwendeten Konstanten benutzt. Die Konstante bestimmt, aus wie vielen Messungen der Mittelwert gebildet wird. Beim Einschalten des Gerätes wird der Wert N auf 2 eingestellt. Dieser Wert kann auf jede positive ganze Zahl von 1 bis 19999 eingestellt werden.

8 X-B**A**

Wird diese Taste gedrückt, subtrahiert das DM 5010 eine gespeicherte Offsetkonstante von einer Messung, dividiert das Ergebnis durch eine gespeicherte Skalierungskonstante und stellt das Ergebnis dar. B ist die Offsetkonstante, A die Skalierungskonstante und X die Messung.

A, B

Diese Tasten werden zum Speichern oder Abrufen von Konstanten verwendet, die zur Berechnung von X-A/B benutzt wurden. Beim Einschalten des Gerätes wird der Wert A auf 1 und der Wert B auf 0 eingestellt. Diese Konstanten können auf jede Zahl (ganze, Dezimal-, positive oder negative Zahl) eingestellt werden, nur der Wert A kann nicht 0 sein.

9 dBm

Wenn diese Taste erleuchtet ist, wird das Verhältnis einer Spannungsmessung, bezogen auf 1 mW und 600 Ohm nach folgender Formel berechnet:

$$\text{dBm} = 20 \log_{10} \left| \frac{x_1}{\sqrt{6}} \right|$$

dabei ist x_1 die Spannungsmessung. Es wird der Logarithmus des absoluten Wertes von $x_1/\sqrt{6}$ genommen.

dBr

Ist diese Taste erleuchtet, berechnet das DM 5010 mit der nachstehende Formel das logarithmische Verhältnis einer Messung zu einer gespeicherten Bezugskonstanten (Taste ref):

$$\text{dBr} = 20 \log_{10} \left| \frac{x_1}{\text{ref}} \right|$$

wobei x_1 die Messung ist. Es wird der Logarithmus des absoluten Wertes von x_1/ref genommen.

ref

Diese Taste wird zum Speichern oder Abrufen einer für die dBr Berechnung benutzten Konstanten verwendet. Beim Einschalten wird der Wert ref auf 1 eingestellt. Der Wert von ref kann jede Zahl außer 0 sein.

10 COMPARE

Die Aktivierung dieser Berechnung (Taste erleuchtet) veranlaßt das DM 5010 die nächste Messung mit den durch die Konstanten LIMITS gesetzten Grenzwerten zu vergleichen. Wenn die verglichene Messung algebraisch unter den beiden Konstanten liegt, wird das Wort LO dargestellt. Ist sie algebraisch größer als die beiden Konstanten wird HI dargestellt. PASS wird dargestellt, wenn die Messung gleich ist oder zwischen den Konstanten liegt.

LIMITS (2)

Diese Tasten werden zum Speichern oder Abrufen von Konstanten verwendet, die als Grenzwerte in der Berechnung COMPARE benutzt wurden. Beim Einschaltvorgang werden die Werte der Konstanten auf 0 eingestellt.

11 RECALL CONST

Drücken dieser Taste und dann eine der Konstantentasten (N, A, B, ref, LIMITS) veranlaßt das Gerät, den für diese Konstante gespeicherten Wert darzustellen.

12 REAR INPUT! 

Siehe „Messungen an der rückseitigen Schnittstelle“ im Abschnitt „Betriebshinweise“. Wenn diese Taste erleuchtet ist, werden statt der Eingänge auf der Frontplatte die Eingänge der rückseitigen Schnittstelle gewählt.

13 DIGITS (0 bis 9), Dezimalpunkt und Zeichen

Diese Tasten werden für die Eingabe von Zahlen, Dezimalstellen und der Polarität für die Speicherung von Konstanten verwendet.

CLEAR

Wenn im Anzeigefenster ein Fehlercode dargestellt wird, löscht diese Taste den dargestellten Fehlercode. Wird die Taste CLEAR während der Eingabe einer Konstanten gedrückt, wird ein Konstantenwert, der noch nicht eingegeben worden ist, auf der Anzeige gelöscht.

ENTER

Durch Drücken dieser Taste bei der Eingabe einer Konstanten wird die Zahl der Konstanten gespeichert und der gespeicherte Konstantenwert dargestellt.

INST ID

Die Aktivierung dieser Taste veranlaßt das Gerät seine Primäradresse darzustellen und, wenn USEREQ freigegeben ist, eine Serviceabfrage (SRQ) am GPIB zu erzeugen. Ferner leuchtet in der Betriebsart Talk Only das Minuszeichen auf und der ganz rechts stehende Dezimalpunkt leuchtet auf, wenn als Endezeichen LF/EOI gewählt wurde; der Dezimalpunkt leuchtet nicht, wenn das Endezeichen EOI ONLY ist.

INPUT

14

HIGH Anschluß

Isolierter analoger positiver Anschluß, der mit den LOW und GUARD Anschlüssen für alle Messungen auf der Frontplatte verwendet wird.

LOW Anschluß

Isolierter analoger Anschluß, der mit dem HIGH Eingangsanschluß verwendet wird.

GUARD Anschluß

Isolierter Anschluß, der mit der Abschirmung der Analogschaltkreise verbunden ist. Wird keine GUARD Prüfleitung verwendet, ist GUARD über einen internen Schalter mit dem LOW Anschluß verbunden. Wird eine GUARD Prüfleitung benutzt, wird sie normalerweise vom Anwender mit der LOW Prüfleitung am Meßpunkt angeschlossen. Der Anschluß GUARD wird zur Maximierung der Gleichtaktunterdrückung verwendet.

15

Masse-Anschluß

Chassis Masseanschluß.

16

Entriegelungshebel

Beim Herausnehmen des Einschubs ziehen.

BEDIENUNGSHINWEISE

Nachstehend werden die Bedienungselemente und Anschlüsse auf der Frontplatte des DM 5010 bei Eigenbedienung beschrieben.

Selbst-Test

Nach dem Einschalten durchläuft das DM 5010 eine Selbsttest-Routine. Während des Selbsttests sind alle LED's auf der Frontplatte erleuchtet. Nach dem Selbsttest schaltet das Gerät auf Eigenbedienung (LOCS) und nimmt die in Tabelle 2-1 enthaltenen Einstellungen an.

**Tabelle 2-1
EINSCHALT-EINSTELLUNGEN
(NUR FUNKTIONEN AUF DER FRONTPLATTE)**

| Funktion | Status |
|-------------------|-----------------------------------|
| DCV | on |
| OHMS | off |
| NULL | (off) Konstante auf 0 eingestellt |
| DIODE TEST | off |
| ACV | off |
| ACV + DCV | off |
| LOW FREQ RESPONSE | off |
| AUTO | on |
| STEP | off |
| RUN | on |
| TRIGGERED | off |
| FAST | off |
| AVERAGE | off |
| N | Konstante auf 2 eingestellt |
| <u>X-B</u> | |
| A | off |
| A | Konstante auf 0 eingestellt |
| B | Konstante auf 1 eingestellt |
| dBm | off |
| dBr | off |
| ref | Konstante auf 1 eingestellt |
| COMPARE | off |
| LIMITS | Konstante auf 0, 0 eingestellt |
| REAR INPUT | off |

Wird während des Selbsttests ein interner Fehler entdeckt, zeigt das Gerät im Anzeigefenster kontinuierlich einen 3-stelligen Fehlercode an und das Lämpchen ERROR leuchtet auf. Siehe Tabelle 2-2. Überlassen Sie Fehlerzustände dem qualifizierten Fachpersonal.

**Tabelle 2-2
FEHLERCODES**

| Anzeige | Fehler |
|---------|--|
| 205 | Ausführungsfehler: Argument außerhalb des Bereichs Nicht kalibrierte Betriebsart Nicht kalibrierbar |
| 231 | |
| 232 | |
| 303 | Interne Fehler: Rechenfehler Konverterausfall Frontplattenausfall Schlechte Kalibrierkonstante RAM Fehler RAM Fehler Kalibrier-Prüfsummenfehler ROM Plazierungsfehler C000 ROM Plazierungsfehler D000 ROM Plazierungsfehler E000 ROM Prüfsummenfehler C000 ROM Prüfsummenfehler D000 ROM Prüfsummenfehler E000 ROM Prüfsummenfehler F000 |
| 311 | |
| 317 | |
| 318 | |
| 340 | |
| 341 | |
| 351 | |
| 372 | |
| 373 | |
| 374 | |
| 392 | |
| 393 | |
| 394 | |
| 395 | |

Allgemeine Betriebshinweise

Das Gerät erreicht seine spezifizizierte Genauigkeit nach 30 Minuten Aufwärmzeit. Bei Bereichsüberschreitung der Funktionen OHMS und DIODE TEST zeigt das Gerät OC an; Bereichsüberschreitung bei den Funktionen DCV, ACV und ACV + DCV wird durch eine blinkende Darstellung angezeigt.



Beachten Sie die spezifizierten Maximalwerte für die Eingangsspannung. Überschreiten der Maximalwerte kann zu Schäden am Gerät führen.

Für alle Meßfunktionen erfolgt die Bereichswahl entweder automatisch (Taste AUTO eingedrückt) oder es wird mit der Taste STEP ein fixierter Bereich ausgewählt. Siehe auch Abschnitt „Anzeigefenster“. Für DIODE TEST wird nur der Bereich 2 V verwendet.

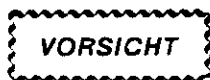

Bei der AUTO Bereichswahl darf die Eingangsspannung nicht wiederholt zwischen einem niedrigen Wert ($< 200 \text{ mV}_S$) und einem höheren Wert ($> 200 \text{ V}_S$) hin und her geschaltet werden. Verwenden Sie für wiederholte Messungen zwischen den Spannungsextremen vor Erhöhung der Eingangsspannung mit der Bereichswahl STEP einen entsprechend höheren Bereich, da sonst ungenaue Messungen im 200 mV Bereich vorkommen können.

Eingangs-Anschlüsse

Die Anschlüsse HIGH, LOW und GUARD werden für Messungen auf der Frontplatte verwendet. Diese Anschlüsse besitzen zwischen dem LOW und GUARD Anschluß einen internen Schalter. Der Schalter ist geschlossen, bis eine Prüflitung am Anschluß GUARD eingesteckt wird; er bleibt offen, bis die Prüflitung entfernt wird.

Bild 2-4 zeigt drei Beispiele für Messungen mit den Anschlüssen auf der Frontplatte. Methode A zeigt die am meisten verwendete Art. Sie wird benutzt, wenn Gleichtaktspannung nicht in Betracht kommt. In diesem Beispiel werden nur die HIGH und LOW Anschlüsse des DM 5010 benutzt. Da am GUARD Anschluß keine Prüflitung eingesteckt ist bleibt der interne Schalter geschlossen und schließt LOW und GUARD kurz. Dadurch kann der Gleichtaktstrom durch die LOW Prüflitung und die Erdung der Spannungsversorgung fließen und zu Meßfehlern führen.

Wenn Gleichtaktspannungen ein Problem sind, liefert Methode B die genauesten Messungen. Der Anschluß GUARD am DM 5010 ist mit dem negativen Anschluß der Signalquelle verbunden. Der Gleichtaktstrom fließt durch die GUARD Prüflitung und die Erdung der Quelle, aber nicht durch den Meßkreis.

Bei Methode C ist der GUARD Anschluß am DM 5010 mit der Erdung der Quelle verbunden. Da der zwischen dem negativen Anschluß der Quelle und der Erdung erzeugte Gleichtaktstrom in den Meßkreis fließt, können Meßfehler auftreten.

WARNUNG

Um die Gefahr von Stromschlägen bei Spannungsmessungen zu vermeiden:

1. Vermeiden Sie den Kontakt mit der Spannungsquelle wenn die gemessene Spannung $42,4 \text{ V}_S$ übersteigt.
2. Trennen Sie die Prüflitungen von dem zu prüfenden Schaltkreis bevor Sie die Leitungen am DM 5010 entfernen und bevor Sie das DM 5010 aus der Versorgungseinheit herausnehmen.

Messungen an den rückseitigen Interface-Anschlüssen!



Wenn die Taste REAR INPUT gedrückt ist (erleuchtet) werden Signale gemessen, die an die rückseitigen Interface-Stifte 28B (Hi) und 28A (Lo) auf der ADC Platine (A17) angelegt sind. Ist die Taste nicht erleuchtet, werden die Signale über die Eingangsanschlüsse auf der Frontplatte gemessen.



Bild 2-4. Beispiele für Anschlußarten auf der Frontplatte.



Um Beschädigung des Gerätes zu vermeiden, darf zwischen den Stiften 28B (Hi) und 28A (Lo) am rückseitigen Interface-Anschluß P1031 auf der ADC Platine (A17) keine Spannung angelegt werden, die 42,4 V_S AC oder 60 V DC übersteigt.

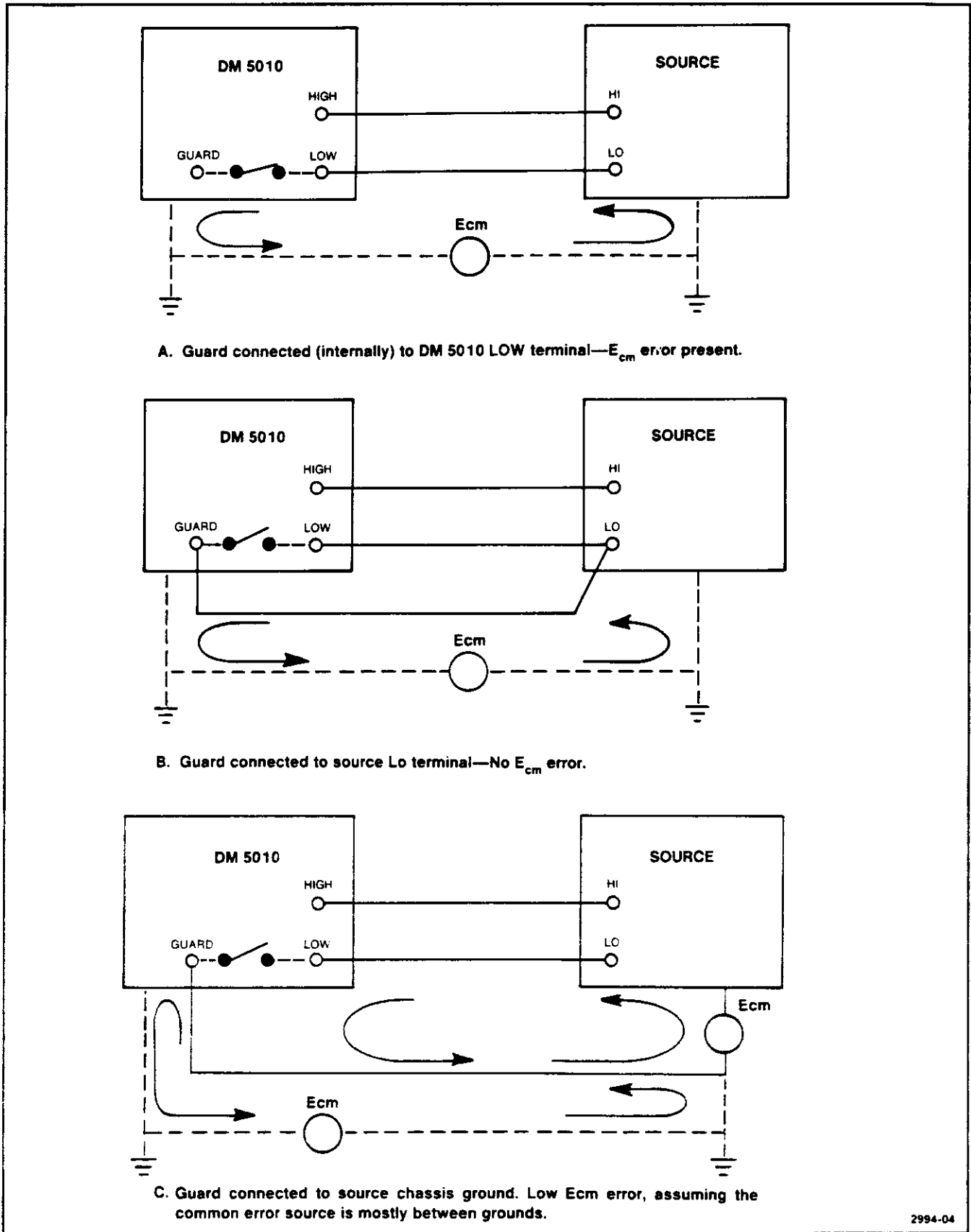

Schalten Sie nicht zwischen der Frontplatte und dem rückseitigen Interface-Anschluß um, während an den Eingangsanschlüssen auf der Frontplatte eine Spannung von über 500 V_S angelegt ist. Betriebsfehler und eine Beschädigung des Gerätes können die Folge sein.

Gleichspannungs- (DC) Messungen

Wenn die Taste DCV gedrückt ist, mißt das DM 5010 Gleichspannungen in den Bereichen: 200 mV, 2 V, 20 V, 200 V und 1000 V. Die Darstellung zeigt ein positives Zeichen an wenn der Eingang am HIGH Anschluß mit Bezug auf den LOW Anschluß positiv ist. Beachten Sie die Maximalwerte für die Eingangsspannung.

Widerstandsmessungen

Drücken der Taste OHMS gibt das DM 5010 frei für die Messung von Widerständen in den Bereichen: 200 Ω, 2 kΩ, 20 kΩ, 200 kΩ, 2 MΩ und 20 MΩ. Der normale Stromfluß geht vom Anschluß HIGH zum Anschluß LOW. Tabelle 2-3 enthält die Strom- und maximalen Spannungswerte an den Eingangsanschlüssen (innerhalb der Bereiche). Die maximale Spannung am Anschluß HIGH bezogen auf Anschluß LOW liegt unter 5 V.

Tabelle 2-3
Funktion OHMS

| Bereich | Typischer Strom | V max. |
|---------|---------------------|--------|
| 200 Ω | 1,02 mA bis 1 mA | 0,2 V |
| 2 kΩ | 0,12 mA bis 0,1 mA | |
| 20 kΩ | 9,2 µA bis 10 µA | |
| 200 kΩ | 1,08 µA bis 1 µA | |
| 2 MΩ | 0,12 µA bis 0,1 µA | |
| 20 MΩ | 0,12 µA bis 0,04 µA | 0,8 V |

Messung von Dioden

Wird die Taste DIODE TEST gedrückt, erzeugt das DM 5010 am Anschluß HIGH einen Gleichstrom von 1 mA. Zur Messung des Spannungsabfalls wird die Diode mit der Anode an HIGH und der Kathode an LOW angeschlossen. Es können Geräte mit einem Spannungsabfall unter 1,999 V geprüft werden. Das sind die meisten Dioden und einige LED's.

Zur Prüfung des umgekehrten Spannungsabfalls vertauschen Sie die Anschlüsse der Diode am Gerät. Die Darstellung sollte OC anzeigen.

Meßgeschwindigkeiten

Das DM 5010 arbeitet mit einer von zwei Meßgeschwindigkeiten. Bei der Geschwindigkeit FAST (Taste CONVERSION RATE erleuchtet) führt es Messungen mit der maximalen, für die gewählte Funktion spezifizierten, Geschwindigkeit durch. Die Meßergebnisse werden 3 1/2-stellig angezeigt. Ist die Taste nicht erleuchtet erfolgen die Messungen mit der normalen für die gewählte Funktion spezifizierten Geschwindigkeit und die Ergebnisse werden 4 1/2-stellig angezeigt.

Triggerung

Das DM 5010 verfügt von der Frontplatte aus über zwei Triggerbetriebsarten RUN und TRIGGERED. Wenn die Taste RUN gedrückt ist erfolgen die Messungen frei laufend mit der gewählten Meßgeschwindigkeit. Bei jedem Drücken der Taste TRIGGERED wird eine Messung ausgelöst.

Ferner können Messungen über den rückseitigen Interface-Anschluß, Stifte 16A und 16B (Lo) am Isolation Board (A15) getriggert werden. Dazu muß eine interne Überbrückung installiert werden. Hinweise dazu findet qualifiziertes Servicepersonal im Abschnitt „Wartung“. Durch Einbau dieser Brücke wird die Triggerfunktion EXTRIG freigegeben. Zur Anwendung der EXTRIG Triggerung drücken Sie die Taste TRIGGER und sperren damit die frei laufende Triggerung des Gerätes. Für die Auslösung der internen Triggerung wird bei EXTRIG ein negatives, TTL kompatibles Signal benötigt. Für eine einzelne Triggerung muß diese Leitung zwischen 0,5 und 10 µs gehalten werden. Wird sie längere Zeit niedrig gehalten, triggert das Gerät Mehrfachmessungen.

Berechnungen

Berechnungen von Messungen des DM 5010 werden mit fünf Tasten auf der Frontplatte aktiviert. Diese Berechnungen können einzeln oder in Folge durchgeführt werden. Eine Folge von Berechnungen kann in beliebiger Reihenfolge aktiviert (Tasten gedrückt) werden; das DM 5010 führt sie jedoch in nachstehender Reihenfolge durch: AVERAGE, X-B/A, dBm oder dBr, COMPARE. Das Gerät führt alle aktivierten Berechnungen der Messung durch und stellt dann das Ergebnis dar. Wenn aktiviert, werden NULL und LOW FREQ RESPONSE vor jeder anderen Berechnung ausgeführt. Die Berechnungen dBm und dBr können nicht in der gleichen Folge durchgeführt werden. Wenn beide Tasten in der gleichen Berechnungsfolge gedrückt werden, wird nur die zuletzt gedrückte Berechnung ausgeführt. Eine Triggerung löst die Durchführung einer einzelnen Berechnung oder einer Berechnungsfolge aus. In der Triggerbetriebsart RUN wird eine aktivierte Berechnung oder Berechnungsfolge wiederholt bis sie abgeschaltet wird (Berechnungstasten nochmals gedrückt), oder bis Triggerart oder Meßfunktion geändert werden. Während der Berechnung bleiben die Anzeige-LED's dunkel. Bei Überfließen der Berechnungsergebnisse zeigt das Gerät OC an.

Außer für dBm werden für jede Berechnung eine oder mehrere Konstanten verwendet. Der für jede Konstante im Speicher erhaltene numerische Wert wird beim Einschalten auf einen Anfangswert eingestellt. Dieser Wert kann auf jeden Wert, innerhalb der für jede Konstante spezifizierten Grenzwerte eingestellt werden. Tabelle 2-4 enthält jede Berechnung und die zugeord-

neten Konstanten, den Konstanten-Anfangswert und die Grenzwerte für jede Konstante.

Änderung der Konstantenwerte

Es gibt zwei Methoden zur Änderung von Konstantenwerten im Gerätespeicher:

1. Mit dem numerischen Tastenfeld:
 - a. Drücken Sie die Taste der gewählten Konstanten.
 - b. Drücken Sie die numerischen Tasten zur Darstellung des neuen Konstantenwertes (innerhalb der in Tabelle 2-4 spezifizierten Grenzwerte).
 - c. Drücken Sie ENTER.

2. Mit einer angezeigten Messung (ändert den Konstantenwert auf den Wert der angezeigten Messung). Achten Sie darauf, daß der angezeigte Meßwert innerhalb der in Tabelle 2-4 für die gewählte Konstante spezifizierten Grenzwerte liegt.
 - a. Drücken Sie die Taste der gewählten Konstanten.
 - b. Drücken Sie ENTER.

**Tabelle 2-4
BERECHNUNG UND KONSTANTEN**

| Berechnung | Konstanten | Anfangswert | gültiger Konstantenbereich |
|------------|-----------------|-------------|--|
| AVERAGE | N | 2 | + 1 bis + 19999 |
| X-B A | B (Offset) A | 0 1 | + oder -, ganze Zahl oder dezimal, + oder -, ganze Zahl oder dezimal, ≠ 0 |
| dBm | - | - | - |
| dBr | ref | 1 | + oder -, ganze Zahl oder dezimal, ≠ 0 |
| COMPARE | LIMITS (2) | 0 | |

Nachdem die Taste ENTER gedrückt wurde, zeigt das DM 5010 den gespeicherten Konstantenwert an. Das ist der neue Wert, wenn der eingegebene Wert gültig ist. Der vorher gespeicherte Wert wird angezeigt, wenn der eingegebene Wert ungültig war. Jeder Konstantenwert bleibt gespeichert bis ein neuer Wert eingegeben oder das Gerät abgeschaltet wird.

Berechnungsbeispiele

Die nachstehenden Beispiele sind Anwendungsvorschläge für Berechnungen mit dem DM 5010.

Beispiel 1: Verwendung von X-B/A zur Darstellung der Differenz zwischen den nominalen und aktuellen Zenerspannungen.

Stellen Sie die Bedienungselemente auf der Frontplatte des DM 5010 wie folgt ein:

| | |
|-------------------|----------|
| DCV | on |
| NULL | off |
| LOW FREQ RESPONSE | off |
| RANGE | AUTO |
| TRIGGER MODE | RUN |
| CONVERSION RATE | FAST off |
| CALCULATIONS | |
| <u>X-B</u> | |
| A | on |
| alle anderen | off |
| REAR INPUT | off |

Stellen Sie die Konstante A auf 1.

Stellen Sie die Konstante B auf 15 (für eine 15 V Zenerdiode).

Verbinden Sie die Zenerdiode, Widerstand und Spannungsquelle wie in Bild 2-5 gezeigt mit den Eingangsschlüssen des DM 5010. Der Wert des Widerstandes und die Spannung stellen den Zenerstrom ein.

Die angezeigte Spannung ist zuerst unstabil bis der Strom durch die Diode den Endwert erreicht. Wenn sich die Anzeige stabilisiert, zeigt die Spannung die Differenz zwischen der nominalen Zenerspannung (15 V/ und der aktuellen Zenerspannung an.

Zur Ablesung der Spannungsdifferenz in Abweichungsprozenten, ändern Sie die Konstante A auf .15, wobei $A = B (.01)$ ist.

Beispiel 2: Verwendung von dBr zum Finden des Punktes an dem ein Audioverstärker 3 dB unterhalb des mittleren Bereiches liegt.

Stellen Sie die Bedienungselemente wie folgt ein:

| | |
|-------------------|----------|
| ACV | on |
| NULL | off |
| LOW FREQ RESPONSE | off |
| RANGE | AUTO |
| TRIGGER MODE | RUN |
| CONVERSION RATE | FAST off |
| CALCULATIONS | off |
| REAR INPUT | off |

Stellen Sie die Konstante ref auf 1. Verbinden Sie einen Sinusgenerator, den Audioverstärker und das DM 5010 wie in Bild 2-6 gezeigt.



Bild 2-5. Anordnung für Berechnungsbeispiel 1.



Bild 2-6. Anordnung für Berechnungsbeispiel 2.

Stellen Sie den Sinusgenerator auf Mitte Bereich (in diesem Beispiel 5 kHz) ein. Stellen Sie die Amplitude des Sinusgenerators für eine 1 V Anzeige am DM 5010 ein.

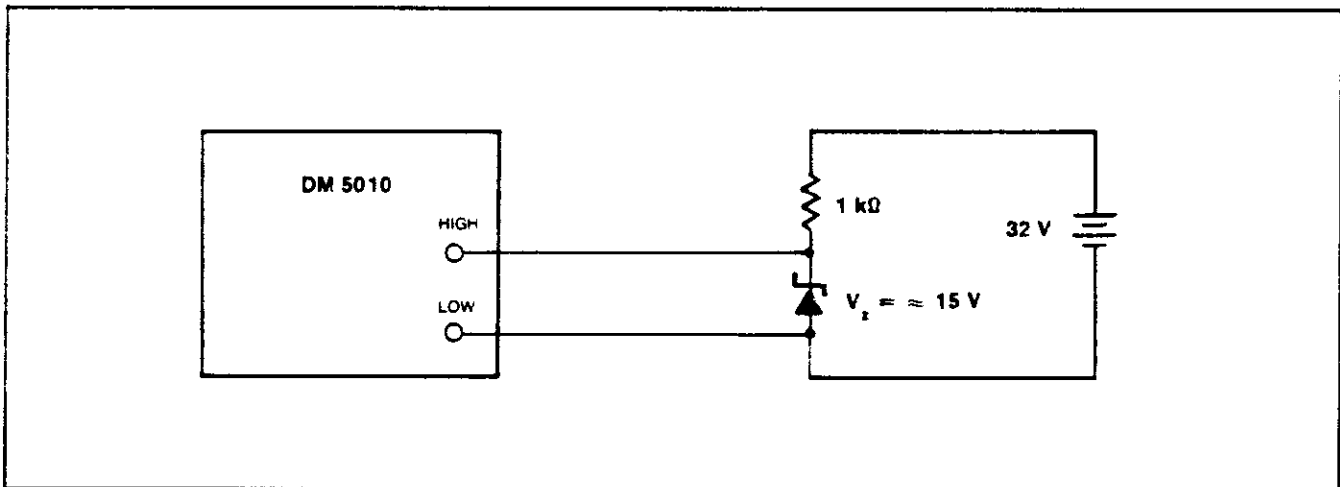
Drücken Sie am DM 5010 die Taste dBr. Das Gerät zeigt 0.0 an.

Reduzieren Sie die Frequenz des Sinusgenerators bis das DM 5010 – 3.00 anzeigt. (Ändern Sie nicht die Amplitude). Die Frequenz des Generators ist der niedrigere – 3 dB Punkt des Audioverstärkers.

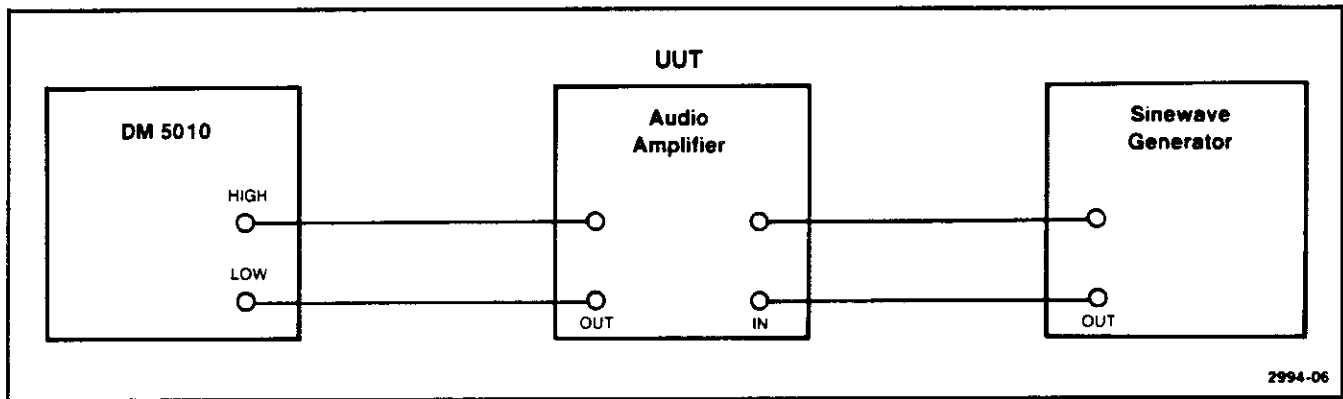
Beispiel 3: Die Verwendung von COMPARE zur Auswahl von Widerständen, die innerhalb von 2% des Nennwertes liegen.

Stellen Sie die Bedienungselemente wie folgt ein:

- | | |
|-------------------|----------|
| OHMS | on |
| NULL | off |
| LOW FREQ RESPONSE | off |
| RANGE | AUTO |
| TRIGGER MODE | RUN |
| CONVERSION RATE | FAST off |
| CALCULATIONS | |
| COMPARE | on |
| alle anderen | off |
| REAR INPUT | off |

Zur Auswahl von 15 kΩ Widerständen, die innerhalb von 2% des Nennwertes liegen stellen Sie eine LIMITS Konstante auf 15300. Die andere LIMITS Konstante stellen Sie auf 14700. Verbinden Sie den ersten Widerstand mit den HIGH und LOW Eingangsanschlüssen auf der Frontplatte des DM 5010. Das DM 5010 zeigt HI oder LO an, wenn der Widerstand oberhalb oder unterhalb der 2% Toleranz liegt. PASS wird angezeigt wenn der Widerstand innerhalb der Grenzwerte liegt.

Die Berechnungsarten COMPARE und X-B/A können in dem vorstehenden Beispiel auch kombiniert verwendet werden. Dabei müssen die höchsten und niedrigsten Toleranzwerte nicht angegeben werden; nur der Nennwert des Widerstandes und der Toleranzwert werden als Konstanten benutzt.

Stellen Sie die Konstante B auf 15000 (Nennwiderstand).

Stellen Sie die Konstante A auf 150 wobei $A = B \cdot (.01)$ ist. Dadurch wird die Differenz zwischen Nennwert und tatsächlichem Wert in einen Prozentsatz umgewandelt.

Stellen Sie eine LIMITS Konstante auf 2 (für 2% Toleranz).

Stellen Sie die andere LIMITS Konstante auf –2.

Drücken Sie X-B/A.

Das DM 5010 zeigt PASS, HI oder LO an.

PROGRAMMATION

Introduction

Ce chapitre est relatif à la programmation du Multimètre Numérique Programmable DM 5010, par l'intermédiaire de l'interface numérique IEEE-488. Les fonctions de l'interface relatives au DM 5010 sont indiquées au chapitre 1. L'interface numérique IEEE-488 est appelée dans ce manuel Bus d'Interface Général (GPIB). Les informations qui suivent s'adressent à un lecteur déjà familiarisé avec les communications sur le GPIB et la programmation des contrôleurs. Le protocole des messages transmis sur le GPIB est spécifié et décrit dans les normes IEEE 488-1978, "Interface Numérique Standard pour Instruments Programmables". Les instruments de la série TM 5000 sont conçus pour communiquer avec tout contrôleur compatible GPIB transmettant et recevant des messages ASCII (commandes) sur le bus GPIB. Ces messages sont constitués de commandes de programmation de l'instrument ou de demandes d'informations issues de l'instrument.

Les commandes des instruments programmables de la série TM 5000 sont compatibles avec d'autres types d'instruments. La même commande peut être utilisée par différents instruments pour le contrôle de fonctions similaires. En outre, chaque commande se présente sous forme d'un mnémonique décrivant sa fonction. Par exemple, la commande INIT réinitialise les réglages d'un instrument en restaurant les conditions de mise en service. De plus, les mnémoniques de commande coïncident avec les appellations en face avant (programmation simplifiée).

Les commandes de l'instrument sont présentées dans ce manuel sous trois formes :

- Une illustration de la face avant - et les commandes ayant trait aux différents modes d'utilisation (v. fig. 3.1).
- Une liste des commandes fonctionnelles - réparties par groupes. Chaque fonction est décrite brièvement.
- Une liste de commandes détaillées - liste alphabétique des commandes. Chaque commande est suivie de sa description complète.

Les instruments programmables de la série TM 5000 sont connectés sur le Bus GPIB par l'intermédiaire d'un module d'alimentation TM 5003 ou TM 5006. Des informations sur l'installation de l'instrument dans le module d'alimentation, ainsi que la description des diverses fonctions en face avant et des fonctions sélectionnables (internes) sont données au chapitre Instructions d'Utilisation.

L'adresse primaire du DM 5010 (16) peut être modifiée par un personnel de maintenance qualifié, ainsi que la Fin de Message (v. dans ce même chapitre le paragraphe Messages et Protocole de Communication). Cette Fin de Message est réglée sur EOI ONLY (à la livraison). Pour toute information sur une localisation ou un réglage interne, se référer au chapitre Maintenance. Une pression sur le bouton INST ID entraîne l'affichage de l'adresse primaire ; le point décimal droit s'allume si la Fin de Message sélectionnée est LF/EOI. Le signe "moins" s'allume si le mode Emetteur Seulement est validé.

Mode Emetteur Seulement (Talk Only)

Ce mode valide l'envoi de données sur le GPIB par le DM 5010 à un Récepteur, sous contrôle local. Pour cela, le commutateur interne correspondant doit être placé sur la position Talk Only. Pour modifier la position de ce commutateur s'adresser à un personnel de maintenance qualifié (v. Chapitre Maintenance).

En mode Emetteur Seulement, le DM 5010 commence à transmettre les résultats de la mesure lorsque l'utilisateur appuie sur le bouton INST ID. Une pression sur la touche CLEAR met fin à l'envoi de données. Si, à cet instant, l'instrument est en train de transmettre une mesure, il termine l'opération en cours. Le voyant ADDRESSED demeure allumé jusqu'à ce que la dernière mesure ait été transmise.

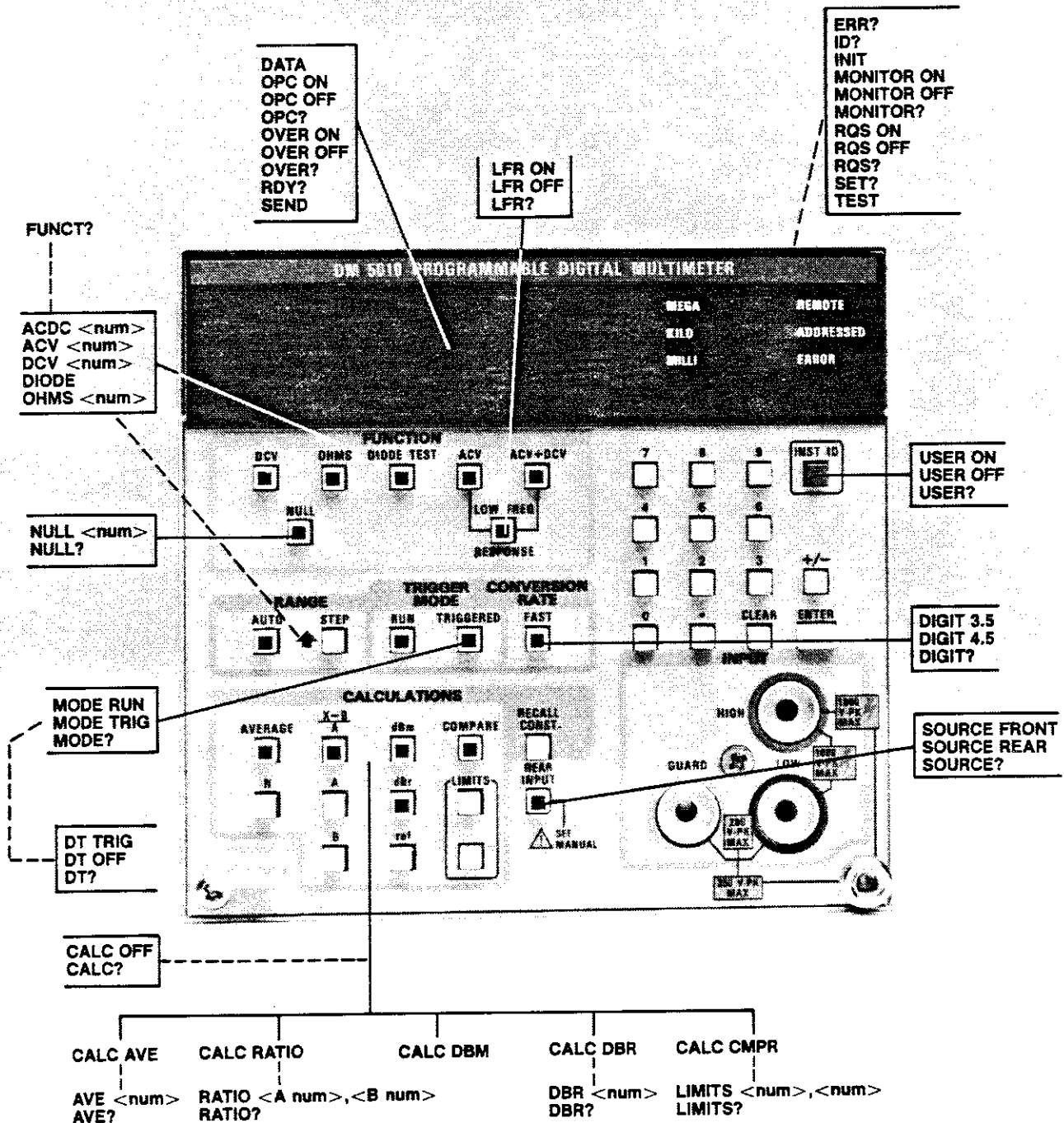

Fig. 3.1. Commandes du DM 5010 et relations avec les commandes de la face avant.

COMMANDES

L'instrument est contrôlé soit par la face avant, soit par les commandes reçues (envoyées par le contrôleur). Ces commandes sont de trois types :

Commandes de réglage - permettent de régler l'instrument

Demandes d'informations - requièrent des données

Commandes d'utilisation - provoquent une opération spécifique.

ATTENTION

Veiller à ne pas transmettre un nombre de caractères inférieur à ceux du mnémonique ou de l'argument abrégé. Toute transmission à un appareil non concerné pourrait entraîner un risque d'erreur ou de détérioration de l'appareil.

Le DM 5010 répond à et exécute toute commande lorsqu'il est dans le mode Commande à Distance. En mode Local, les fonctions du DM 5010 étant sous le contrôle de la face avant, toute commande de réglage et de fonction transmise par le contrôleur donne lieu à un message d'erreur. Seules les demandes d'informations sont exécutées.

Chaque commande débute par un mnémonique - préfixe décrivant la fonction exécutée. De nombreuses commandes nécessitent un argument à la suite du préfixe, pour décrire l'état désiré de la fonction concernée.

ATTENTION

En mode Sélection Automatique de Gammes, ne pas passer de manière répétitive d'une tension basse (< 200 mV crête) à une tension élevée (> 200 V crête). Dans ce cas, utiliser le mode Sélection de gammes par incréments (STEP) pour sélectionner la gamme supérieure appropriée avant d'augmenter la tension d'entrée. En travaillant directement dans la gamme 200 mV on risque d'obtenir des mesures erronées.

LISTE DE COMMANDES FONCTIONNELLES

COMMANDES DE L'INSTRUMENT

Commandes de fonctions

ACDC <nombre> - valide la fonction Mesure d'une tension alternative efficace vraie superposée à un niveau continu (ACV + DCV) et définit la gamme de mesure.

ACV <nombre> - valide la fonction Mesure d'une tension alternative efficace vraie (ACV) et définit la gamme de mesure.

DCV <nombre> - valide la fonction Mesure d'une tension continue (DCV) et définit la gamme de mesure.

DIODE - valide la fonction DIODE TEST.

FUNCT? - renvoie la fonction et la gamme actuelles.

LFR ON - valide la fonction Réponse en basse fréquence (LOW FREQ RESPONSE).

LFR OFF - inhibe la fonction Réponse en basse fréquence (LOW FREQ RESPONSE).

LFR? - renvoie LFR ON ou LFR OFF.

NULL <nombre> - valide la fonction Annulation (NULL) et la valeur de décalage utilisée.

NULL ? - renvoie la valeur de décalage utilisée par la fonction NULL.

OHMS <nombre> - valide la fonction Mesure de résistances (OHMS) et la gamme utilisée.

Commandes du mode de déclenchement

MODE RUN - valide le mode Déclenchement relaxé (RUN).

MODE TRIG - valide le mode Déclenché (TRIGGERED).

MODE? - renvoie MODE RUN ou MODE TRIG.

RDY? - renvoie RDY 1 si une mesure est prête ; RDY 0 si une mesure est en cours ou en attente de déclenchement.

DIGIT 3.5 - valide la vitesse de conversion rapide (FAST)

DIGIT 4.5 - valide la vitesse de conversion normale.

DIGIT? - renvoie DIGIT 3.5 ou DIGIT 4.5.

Commandes de calcul

AVE <nombre> - définit la valeur de la constante N.

AVE? - renvoie la valeur de la constante N.

CALC AVE - valide le calcul de la Moyenne (AVERAGE).

CALC CMPR - valide la fonction Comparaison (COMPARE).

CALC DBM - valide la conversion en dBm.

CALC DBR - valide la conversion en dBr.

Programmation - DM 5010

CALC RATIO - valide le calcul de X-B/A.

CALC OFF - inhibe tous les calculs.

CALC ? - renvoie CALC OFF ou le(s) calcul(s) à effectuer.

DBR 8Anombre8F - définit la valeur de la constante de référence (ref).

DBR ? - renvoie la valeur de la constante de référence (ref).

LIMITS <nombre>,<nombre> - définit la valeur des constantes limites (LIMITS).

LIMITS ? - renvoie la valeur des constantes limites.

MONITOR ON - valide une Demande de Service lorsque la mesure excède les constantes limites (LIMITS).

MONITOR OFF - inhibe la Demande de Service lorsque la mesure excède les constantes limites (LIMITS).

MONITOR ? - renvoie MONITOR ON ou MONITOR OFF.

RATIO <nombre>,<nombre> - définit la valeur des constantes A et B.

RATIO ? - renvoie la valeur des constantes A et B.

Commandes d'entrée/sortie

DATA - valide la sortie des données sauvegardées par la commande MONITOR SRQ.

SEND - valide la sortie des données contenues dans la mémoire tampon de sortie. Génère un déclenchement si nécessaire.

SOURCE REAR - sélectionne les entrées de l'interface arrière.

SOURCE FRONT - sélectionne les entrées de la face avant.

SOURCE ? - renvoie SOURCE REAR ou SOURCE FRONT.

Commandes du système

DT TRIG - valide la fonction Déclenchement de l'Instrument. L'instrument est déclenché après le message d'interface <GET8F.

DT OFF - inhibe la fonction Déclenchement de l'Instrument.

DT ? - renvoie DT TRIG ou DT OFF.

ERR ? - renvoie le code d'erreur approprié.

ID ? - renvoie l'identification de l'instrument et le numéro de la version logicielle.

INIT - initialise les réglages de l'instrument.

SET ? - renvoie les réglages de l'instrument.

TEST - renvoie 0 si le contrôle de l'étalement est correct ; 1 si le checksum de l'étalement est erroné.

Commandes d'état

OPC ON - valide la Demande de Service après une Opération Complète.

OPC OFF - inhibe la Demande de Service après une Opération Complète.

OPC ? - renvoie OPC ON ou OPC OFF.

OVER ON - valide la Demande de Service lors d'un dépassement de gamme.

OVER OFF - inhibe la Demande de Service lors d'un dépassement de gamme.

OVER ? - renvoie OVER ON ou OVER OFF.

RQS ON - valide la génération de demandes de service (SRQ).

RQS OFF - inhibe la génération de demandes de service (SRQ).

RQS ? - renvoie RQS ON ou RQS OFF.

USER ON - valide la Demande de Service lorsque le bouton ID est enfoncé.

USER OFF - inhibe la Demande de Service lorsque le bouton ID est enfoncé.

USER ? - renvoie USER ON ou USER OFF.

LISTE DES COMMANDES DETAILLEES

ACDC (AC + DC)

(Mesure d'une tension alternative efficace vraie superposée à une tension continue)

Type :

Réglage

Syntaxe de réglage :

ACDC <nombre>
ACD <nombre>
ACDC

Exemples :

| | |
|----------|------------------------------|
| ACDC 2 | 2 V |
| ACDC .9 | 2 V |
| ACD -200 | 700 V, Sélection Automatique |
| ACD | 700 V, Sélection Automatique |
| ACD 0 | 700 V, Sélection Automatique |

Gamme sélectionnée :

Explication :

Le préfixe sélectionne la fonction ACV + DCV. L'argument sélectionne une gamme déterminée ou la Sélection Automatique de Gammes. Le format des arguments numériques est décrit au paragraphe Format de l'argument numérique de ce chapitre. L'argument peut être toute valeur ≤ 700 . Toutefois, l'instrument arrondit l'argument à la gamme supérieure. Par exemple, si l'argument est 0.9, l'instrument sélectionne la gamme 2 V.

Un argument absent, ou égal à 0 (ou moins) valide le mode Sélection Automatique de Gammes (à partir de la gamme maximale).

Si l'argument est supérieur à la gamme maximale, l'instrument génère une "erreur" de commande (et valide la ligne SRQ si la commande RQS est validée (RQS ON)).

Gammes :

| | |
|--------|-----|
| 200 mV | 2 V |
| 20 V | |
| 200 V | |
| 700 V | |

ACV

(Mesure d'une tension alternative efficace vraie)

Type :

Réglage

Syntaxe de réglage :

ACV <nombre>
ACV

Exemples :

| | |
|----------|--|
| ACV 18 | 20 V |
| ACV 2 | 2 V |
| ACV -200 | 700 V, Sélection Automatique de Gammes |
| ACV | 700 V, Sélection Automatique de Gammes |

Gamme sélectionnée :

Explication :

Le préfixe sélectionne la fonction ACV. L'argument sélectionne une gamme déterminée ou la Sélection de Gammes Automatique. Le format des arguments numériques est décrit au paragraphe Format de l'argument numérique de ce chapitre. L'argument peut prendre toute valeur. Toutefois, l'instrument arrondit l'argument à la gamme supérieure. Par exemple, si l'argument est 18, l'instrument sélectionne la gamme 20 V.

Un argument absent, ou égal à 0 (ou moins) valide le mode Sélection Automatique de Gammes (à partir de la gamme supérieure).

Si l'argument est supérieur à la gamme maximale, l'instrument génère une "erreur" de commande (et valide la ligne SRQ si la commande RQS est validée (RQS ON)).

Gammes :

| | |
|--------|-----|
| 200 mV | 2 V |
| 20 V | |
| 200 V | |
| 700 V | |

Programmation - DM 5010

AVE **(AVERAGE (Moyenne))**

Type :

Réglage ou interrogation

Syntaxe de réglage

AVE <nombre>

AVG <nombre>

Exemples :

AVE 6

AVE 2

AVG 10

Syntaxe d'interrogation :

AVE?

AVG?

Réponse à l'interrogation :

AVE <nombre>

Explication :

Cette commande spécifie le nombre de conversions utilisées dans le calcul de la Moyenne. (Ceci équivaut à définir la valeur de la constante N en face avant). Voir CALC AVE. L'argument peut prendre n'importe quelle valeur de 1 à 19999. L'instrument arrondit cet argument à un nombre entier.

CALC (Calculs)

Type :

Réglage ou interrogation

Syntaxe de réglage :

CALC <argument>
CALC <argument>,.....,<argument>

Arguments :

AVE ou AVG
CMPR ou COMP
DBM
DBR
RATIO
OFF

Exemples :

CALC OFF
CALC AVE
CALC AVE,DBM
CALC RATIO,AVE,DBR

Syntaxe d'interrogation :

CALC?

Réponse à l'interrogation :

CALC OFF ; ou le(s) calcul(s) à effectuer.

Explication :

Lorsque l'instrument reçoit une commande CALC, il inhibe tous les calculs exceptés ceux indiqués à la suite du préfixe. Si le résultat d'un calcul excède les capacités du bloc mathématique ($\pm 3.4028E+38$), l'instrument génère une erreur concernant le Bloc mathématique (erreur 303).

- CALC AVE ou CALC AVG valide le calcul de la Moyenne. L'instrument calcule la

moyenne d'une série de mesures. Le nombre de mesures moyennées est défini par la commande AVE <nombre>.

Un déclenchement génère un nombre suffisant de lectures pour effectuer une moyenne. Un dépassement de gamme d'une mesure dans une séquence met fin à la fonction AVE.

Si la commande LFR est également validée, le nombre de mesures défini par la commande AVE <nombre> est multiplié par 4.

- CALC CMPR ou CALC COMP valide la fonction COMPARE. L'instrument compare la valeur en entrée aux valeurs définies par la commande LIMITS. Les commandes suivantes valident la sortie du résultat de la comparaison :

SEND - renvoie 1., 2. ou 3. équivalant à LO (inférieure), PASS (égale) ou HI (supérieure) ; renvoie +1E+99; ou -1E+99; pour un dépassement de gamme.

DATA - renvoie la valeur de la mesure hors-limites.

- CALC DBM valide la conversion en dBm et inhibe la conversion en dBr. L'instrument calcule le rapport de la puissance du signal d'entrée par rapport à une puissance de 1 mW dissipée dans une résistance de 600 Ω (0,7446 V).

- CALC DBR valide la conversion en dBr et inhibe la fonction CALC DBM. Le DM 5010 calcule le rapport logarithmique d'une entrée sur la valeur de référence définie par la commande DBR <nombre>.

- CALC RATIO valide le calcul de X-B/A, X étant la mesure, B une valeur de décalage et A le facteur d'échelle. Les valeurs de A et B sont définies par la commande RATIO.

- CALC OFF inhibe tous les calculs.

DATA
(Données)

Type :

Commande de sortie

Syntaxe :

DATA

Réponse :

DATA <nombre>;
ou
DATA ± 1.E+99; *(indication "hors-gamme")*

Explication :

Cette commande renvoie l'une des réponses indiquées ci-dessous. Elle ne déclenche pas une conversion et n'attend pas pour renvoyer une nouvelle mesure, comme la commande SEND.

1. Après la mise en service, renvoie 0 jusqu'à ce qu'une mesure soit disponible.

2. Si une Demande de Service a été générée par la commande MONITOR SRQ, DATA renvoie la mesure à l'origine de la Demande de Service.

3. Si aucune des conditions ci-dessus n'est vraie, DATA renvoie la lecture la plus récente. DATA renvoie la même mesure jusqu'à ce qu'une nouvelle conversion soit déclenchée et qu'une nouvelle mesure soit disponible.

DATA peut renvoyer un nombre de chiffres supérieur (résolution supérieure) au nombre de chiffres affichés en face avant ou renvoyés par la commande SEND.

DBR
(dB par rapport à une référence)

Type :

Réglage ou interrogation

Syntaxe de réglage :

DBR <nombre>

Exemples :

DBR 1
DBR .707
DBR 2E-3

Syntaxe d'interrogation :

DBR?

Réponse à l'interrogation :

DBR <nombre>;

Explication :

L'argument de cette commande définit la valeur de la constante utilisée par la commande CALC DBR. Cette fonction est équivalente à la commande ref en face avant. L'argument peut être tout nombre différent de 0.

DCV
(Mesure d'une tension continue)

Type :

Réglage

Syntaxe de réglage :

DCV <nombre>
DCV

Exemples :

DCV 1.5
DCV

Gamme sélectionnée :

2 V
1000 V, Sélection Automatique
de Gammes
1000 V, Sélection Automatique
de Gammes

Explication :

Le préfixe sélectionne la fonction DCV. L'argument sélectionne une gamme de tension déterminée. Le format de l'argument est décrit dans ce chapitre au paragraphe Format de l'argument numérique. L'argument peut être n'importe quelle valeur. Toutefois, l'instrument arrondit l'argument à la gamme immédiatement supérieure. Par exemple, si l'argument est 1,5, l'instrument choisit la gamme 2V.

Un argument manquant ou égal à 0 (ou moins) valide la Sélection de Gammes Automatique (à partir de la gamme maximale).

Si l'argument est supérieur à la gamme maximale, l'instrument génère une erreur de commande (et une Demande de Service si la commande RQS a été validée (RQS ON)).

Gammes :

200 mV
2 V
20 V
200 V
1000 V

DIGIT
(Résolution numérique)

Type :

Réglage ou interrogation

Syntaxe de réglage :

DIGIT 3.5
DIGIT 4.5
DIG 3.5
DIG 4.5

Syntaxe d'interrogation :

DIGIT?
DIG?

Réponse à l'interrogation :

DIGIT 3.5;
DIGIT 4.5;

Explication :

Cette commande sélectionne la vitesse de conversion. L'argument 3.5 valide la Vitesse de Conversion Rapide (FAST) (résolution d'affichage de 3,5 chiffres). Une mesure de tension dure environ 35 ms. Une mesure de résistance dure environ 130 ms.

L'argument 4.5 valide la Vitesse de Conversion Normale (résolution d'affichage de 4,5 chiffres). Une mesure de tension dure environ 310 ms. Une mesure de résistance dure environ 620 ms.

DIODE
(Test de diode)

Type :

Réglage

Syntaxe de réglage :

DIODE
DIO

Explication :

Cette commande sélectionne la fonction DIODE TEST. Elle n'accepte pas d'argument.

DT
(Déclenchement de l'instrument)

Type :

Réglage ou interrogation

Syntaxe de réglage :

DT TRIG
DT OFF

Syntaxe d'interrogation :

DT?

Réponse à l'interrogation :

DT TRIG;
DT OFF;

Explication :

Cette commande valide ou inhibe la fonction Déclenchement de l'instrument. Cette commande provoque une mesure à l'arrivée du message <GET> de l'interface IEEE 488.

Si <GET> est reçu alors que le processeur de messages est occupé (ou si la commande DT n'a pas été validée), l'instrument génère une "erreur", qui indique que le message <GET> est ignoré.

**ERR?
(Erreur)**

Type :

Interrogation

Syntaxe d'interrogation :

ERR?

Réponse à l'interrogation :

ERR_{SP SP} < nombre >

Exemple :

ERR_{SP SP}401;

Explication :

L'interrogation ERROR est utilisée pour s'informer de l'état de l'instrument.

L'interrogation ERROR renvoie un code indiquant l'évènement à l'origine de la Demande de Service. Se référer au paragraphe Indications d'erreurs et d'états.

**FUNCT?
(Fonction)**

Type :

Interrogation

Syntaxe d'interrogation :

FUNCT?
FUNC?

Exemples de réponse à l'interrogation :

DCV 2.;
ACV 20.;
DIODE;
ACDC 200.;
OHMS -2.E+6;

Explication :

Cette commande renvoie la fonction de mesure utilisée. L'argument spécifie la gamme. Si l'instrument est en mode Sélection Automatique de Gammes, un argument négatif est renvoyé.

Programmation - DM 5010

ID? (Identification)

Type :

Interrogation

Syntaxe d'interrogation :

ID?

Réponse à l'interrogation :

ID TEK/DM5010,V79.1 Fxx;

Explication :

L'interrogation ID? renvoie la réponse ci-dessus.

TEK/DM5010 Identifie le Constructeur et le type de l'Instrument.

V79.1 Identifie la version des Codes et Formats Standard Tektronix à laquelle l'instrument est conforme.

Fxx Identifie la version logicielle de l'instrument.

INIT (Initialisation)

Type :

Commande d'utilisation

Syntaxe :

INIT

Explication :

Cette commande restaure les conditions de réglage de l'instrument à la mise en service. Ces réglages sont indiqués au tableau 3.3.

LFR
(Réponse en Basse Fréquence)

Type :

Réglage ou interrogation

Syntaxe de réglage :

LFR ON
LFR OFF

Syntaxe d'interrogation :

LFR?

Réponse à l'interrogation :

LFR ON;
LFR OFF;

Explication :

Cette commande valide ou inhibe la fonction LOW FREQ RESPONSE (utilisée avec les fonctions ACV et ACV+DCV). Lorsque cette fonction est validée, l'instrument calcule la moyenne de quatre mesures.

Si la fonction CALC AVE est également validée, le nombre de mesures défini par la commande AVE < nombre > est multiplié par 4.

LIMITS
(Limites)

Type :

Réglage ou interrogation

Syntaxe de réglage :

LIMITS < nombre >, < nombre >
LIM < nombre >, < nombre >

Exemples :

LIMITS 3.2, -2
LIMITS -1, -6.5
LIM 6,1

Syntaxe d'interrogation :

LIMITS?
LIM?

Réponse à l'interrogation :

LIMITS < nombre >, < nombre >;

Explication :

L'argument de cette commande définit la valeur des limites utilisées par la fonction COMPARE et la Demande de Service du moniteur. Le premier argument définit la valeur de la limite qui correspond au bouton LIMITS du haut (face avant). Le deuxième argument définit la valeur de la limite qui correspond au bouton LIMITS du bas.

MODE

Type :

Réglage ou interrogation

Syntaxe de réglage :

MODE RUN
MODE TRIG
MOD RUN
MOD TRIG

Syntaxe d'interrogation :

MODE?
MOD?

Réponse à l'interrogation :

MODE RUN;
MODE TRIG;

Explication :

Cette commande sélectionne le mode de déclenchement. L'argument RUN définit le mode Déclenchement Relaxé.

L'argument TRIG définit le mode Déclenché. Dans ce mode, un déclenchement se produit à la réception de :

- une commande SEND
- un message <GET> (Déclenchement simultané de tous les instruments) de l'interface (seulement si le Déclenchement de l'instrument (DT) a été validé)
- Mon adresse en tant qu'Emetteur (MTA), la sortie n'étant pas spécifiée (pas de commande d'interrogation)
- un déclenchement par l'interface arrière (EXTRIG) (nécessite l'installation d'un cavalier interne - voir chapitre Maintenance). Pour l'obtention d'un déclenchement unique, cette ligne doit être maintenue à l'état bas entre 0,5 et 10 μ sec. Son maintien prolongé à l'état bas entraîne le déclenchement de mesures multiples.

Si le signal mesuré est excessif ou insuffisant, en modes Déclenché (MOD TRIG) et Sélection Automatique de Gammes, l'instrument change de gamme et effectue une autre mesure.

MONITOR (Moniteur)

Type :

Réglage ou interrogation

Syntaxe de réglage :

MONITOR ON
MONITOR OFF
MON ON
MON OFF

Syntaxe d'interrogation :

MONITOR?
MON?

Réponse à l'interrogation :

MONITOR ON;
MONITOR OFF;

Explication :

Cette commande valide ou inhibe la Demande de Service du moniteur. Si celle-ci est validée, l'instrument sauvegarde la première mesure hors-limites (cf. commande LIMITS) et génère une Demande de Service (SRQ). Ceci est valable pour la première mesure hors-limites mais non pour les autres jusqu'à ce que la Demande de Service ait été exécutée, et que la mesure ait été renvoyée au contrôleur en réponse à la commande DATA.

Si l'instrument effectue un dépassement de gamme alors que la commande MON ON a été générée, il renvoie une erreur "hors-gamme", même si OVER n'est pas validé (OVER OFF).

NULL
(Annulation)

Type :

Réglage ou interrogation

Syntaxe de réglage :

NULL <nombre>

Exemples :

NULL .2
NULL 0

Syntaxe d'interrogation :

NULL ?

Réponse à l'interrogation :

NULL <nombre>;

Explication :

Cette commande valide la fonction NULL. L'argument (en volts ou en ohms) spécifie la valeur du décalage. Cette valeur peut être toute valeur jusqu'à 100 % de la gamme.

La fonction NULL est inhibée à la sélection d'une autre fonction de mesure ou avec l'argument 0. (La sélection d'une autre fonction met également l'argument à 0).

AVERTISSEMENT

Lorsque la fonction NULL est validée, la mesure peut ne pas indiquer la valeur de la tension appliquée aux connecteurs d'entrée.

OHMS
(Mesure d'une résistance)

Type :

Réglage

Syntaxe de réglage :

OHMS <nombre>
OHMS

Exemples :

OHMS
OHMS 100
OHMS -2E+7
OHMS 1E+4

Gamme sélectionnée :

20 M Ω , sélection automatique de gammes
200 Ω
20 M Ω , sélection automatique de gammes
20 K Ω

Explication :

Le préfixe sélectionne la fonction OHMS. L'argument sélectionne la gamme. Se référer au paragraphe Format des arguments numériques de ce chapitre. L'argument peut être n'importe quelle valeur. Toutefois, l'instrument arrondit l'argument à la gamme immédiatement supérieure.

Par exemple, si l'argument est 100, l'instrument sélectionne la gamme 200 Ω .

Un argument manquant, ou égal à 0 (ou moins) valide la Sélection Automatique de Gammes (à partir de la gamme maximale).

Si l'argument est supérieur à la gamme maximale, l'instrument génère une "erreur" de commande (et valide la ligne SRQ si la commande RQS est validée (RQS ON)).

Gammes :

200 Ω
2 K Ω
20 K Ω
200 K Ω
2 M Ω
20 M Ω

Programmation - DM 5010

OPC (Operation Complète)

Type :

Réglage ou interrogation

Syntaxe de réglage :

OPC ON
OPC OFF

Syntaxe d'interrogation :

OPC?

Réponse à l'interrogation :

OPC ON;
OPC OFF;

Explication :

Cette commande valide ou inhibe la Demande de Service Operation Complète. L'instrument valide la ligne SRQ lorsqu'une nouvelle mesure est disponible si OPC et RQS sont validées (RQS ON)).

OVER (Hors-gamme)

Type :

Réglage ou interrogation

Syntaxe de réglage :

OVER ON
OVER OFF

Syntaxe d'interrogation :

OVER?

Réponse à l'interrogation :

OVER ON;
OVER OFF;

Explication :

Cette commande valide ou inhibe la Demande de Service lors d'un dépassement de gamme. L'instrument valide la ligne SRQ lors d'une mesure hors-gamme (si OVER et RQS sont validées (RQS ON)).

Si la Demande de Service est inhibée, l'instrument renvoie °1.E+99 lorsqu'il est Emetteur, pour indiquer un dépassement de gamme (et ne valide pas la ligne SRQ).

RATIO
(Rapport de mesures)

Type :

Réglage ou interrogation

Syntaxe de réglage :

RATIO <nombre>, <nombre>

Exemples :

RATIO 100,15
RATIO 10,2

Syntaxe d'interrogation :

RATIO?

Réponse à l'interrogation :

RATIO <nombre>, <nombre>;

Explication :

Les arguments de cette commande définissent la valeur du décalage et le facteur d'échelle utilisé dans le calcul de X-B/A. Se référer à la commande CALC RATIO. Le premier argument définit la valeur du facteur d'échelle (bouton A en face avant). Le second définit la valeur du décalage (bouton B). Les arguments peuvent prendre n'importe quelle valeur, à l'exception de 0 pour le facteur d'échelle.

RDY?
(Prêt)

Type :

Interrogation

Syntaxe d'interrogation :

RDY?

Réponse à l'interrogation :

RDY_{SP SP}0;
RDY_{SP SP}1;

Explication :

Cette commande renvoie RDY 0 si une mesure est en cours ou si l'instrument attend un déclenchement ; RDY 1 indique qu'une donnée est disponible.

Programmation - DM 5010

RQS (Demande de Service)

Type :

Réglage ou interrogation

Syntaxe de réglage :

RQS ON
RQS OFF

Syntaxe d'interrogation :

RQS?

Réponse à l'interrogation :

RQS ON;
RQS OFF;

Explication :

Cette commande valide la génération de Demandes de Service. L'argument OFF inhibe toutes les Demandes de Service. Se référer au paragraphe Indications d'états et d'erreurs.

SEND (Envoi)

Type :

Commande de sortie

Syntaxe :

SEND
SEN

Réponse :

< nombre > ; (pas de préfixe)

Exemple :

$\pm 1.E+99$;
 $\pm 3.2E+3$; (dépassement de gamme)

Explication :

Cette commande valide la sortie de la mesure la plus récente. Si aucune mesure n'est disponible, l'instrument déclenche une mesure puis affiche celle-ci.

Si la fonction COMPARE est validée (CALC CMPR), l'instrument affiche l'un des nombres suivants, qui indiquent la relation entre la valeur entrée et la limite définie par la commande LIMITS.

- 3.; si l'entrée est supérieure aux limites.
- 2.; si l'entrée est comprise entre les limites ou égale à l'une des deux limites.
- 1.; si l'entrée est inférieure aux limites.

$+1.E+99$; ou $-1.E+99$; dans le cas d'un dépassement de gamme

SET?
(Réglages?)

Type :

Interrogation

Syntaxe d'interrogation :

SET?

Exemple de réponse à l'interrogation (réglages à la mise en service) :

DCV -1.E+3;AVE 2;RATIO 1.0.; DBR 1.;LIMITS 0..0.;CALC OFF;NULL 0.;DIGIT 4.5;LFR OFF;MODE RUN;SOURCE FRONT;DT OFF;MONITOR OFF;OPC OFF;OVER OFF;USER OFF;RQS ON;

Explication :

Cette commande renvoie les réglages actuels de toutes les commandes.
La réponse la plus longue comprend 225 caractères.

SOURCE

Type :

Réglage ou interrogation

Syntaxe de réglage :

SOURCE FRONT
SOURCE REAR
SOUR FRONT
SOUR REAR

Syntaxe d'interrogation :

SOURCE?
SOUR?

Réponse à l'interrogation :

SOURCE FRONT;
SOURCE REAR;

Explication :

SOURCE FRONT sélectionne les entrées de la face avant pour la mesure. SOURCE REAR sélectionne les entrées de l'interface arrière.

ATTENTION

Si une tension supérieure à 500 V crête est appliquée sur les connecteurs de la face avant, ne pas valider les entrées de l'interface arrière, pour éviter tout risque de détérioration ou de fonctionnement erroné de l'instrument.

Programmation - DM 5010

TEST

Type :

Commande de sortie

Syntaxe :

TEST

Réponse :

TEST 0;
TEST 351;

Explication :

Renvoie un nombre indiquant l'état du checksum (test d'erreur) d'étalonnage : 0 si celui-ci est correct ; 1 si celui-ci est erroné.

USER (Utilisateur)

Type :

Réglage ou interrogation

Syntaxe de réglage :

USER ON
USER OFF

Syntaxe d'interrogation :

USER?

Réponse à l'interrogation :

USER ON;
USER OFF;

Explication :

Cette commande valide ou inhibe la Demande de Service associée au bouton INST ID. Si celle-ci est validée, l'instrument valide la ligne SRQ lorsque le bouton INST ID en face avant est enfoncé.

MESSAGES ET PROTOCOLE DE COMMUNICATION

Délimiteur de commande

Un message consiste en une commande ou une série de commandes, suivies d'une fin de message. Dans le cas de messages constitués de plusieurs commandes, celles-ci doivent être séparées par des points virgules. Un point virgule n'est pas obligatoire en fin de message. Chacune des lignes ci-dessous est un message :

```
INIT
TEST;INIT;RQS ON;USER OFF;ID?;SET?
TEST;
```

Fin de message

Les messages peuvent être terminés par EOI ou le caractère ASCII de saut de ligne (LF). Certains contrôleurs valident la ligne EOI concurremment avec la transmission du dernier octet de données ; d'autres n'utilisent que le caractère LF comme fin de message. L'un ou l'autre peut être sélectionné à l'intérieur du DM 5010. Si EOI ONLY est sélectionné, l'instrument interprète comme fin du message entré tout octet de données reçu. De même, il valide la ligne EOI concurremment avec la transmission du dernier octet du message sorti. Si LF/EOI est sélectionné, l'instrument interprète le caractère LF comme fin du message entré si la ligne EOI est inhibée (ou tout octet de données reçu lorsque la ligne EOI est validée). Il transmet un retour chariot (CR) suivi d'un saut de ligne (LF avec la ligne EOI validée) pour mettre fin aux messages en sortie. Lire le chapitre Maintenance avant la sélection manuelle interne (personnel qualifié) de la fin de message. Les instruments de la série TM 5000 sont livrés avec la fin de message EOI ONLY sélectionnée.

Formattage d'un message

Pour être comprises, les commandes transmises aux instruments de la série TM 5000 doivent avoir le format (ou syntaxe) approprié. Toutefois, ce format est très souple et peut subir de nombreuses variations. Une description de ce format et des variations admises est donnée ci-après.

Toutes les commandes doivent être en code ASCII. Toutefois, les minuscules et majuscules sont acceptées. Toute donnée sortie doit être en majuscules.

Comme expliqué précédemment, une commande consiste en un préfixe suivi, si nécessaire, par des arguments. Une commande suivie d'arguments doit posséder un délimiteur, le caractère SP (SPACE = espace), entre le préfixe et l'argument.

RQS_{SP}ON

Si les caractères formatés spéciaux, SP, CR, et LF (LF ne pouvant être utilisé si le mode LF/EOI est sélectionné) sont ajoutés entre le délimiteur de préfixe et

l'argument, ils sont ignorés par le DM 5010. (SP) (CR) et (LF) sont indiqués en indices dans les exemples qui suivent :

```
Exemple 1 : RQSSPON;
Exemple 2 : RQSSP SPON;
Exemple 3 : RQSSP CR LF
              SP SP ON
```

Dans la liste des commandes, certains préfixes et arguments sont présentés sous une forme complète et sous une forme abrégée. L'instrument accepte tout préfixe ou argument contenant au moins les caractères de la forme abrégée. Les caractères ajoutés à celle-ci doivent être ceux de la forme complète. Pour documenter ses programmes, l'utilisateur peut ajouter des caractères alphanumériques à un mot complet. Des caractères alphanumériques peuvent également être ajoutés à une interrogation, à condition d'être placés avant le point d'interrogation.

```
USER?
USERE?
USEREQ?
USEREQUEST?
```

De nombreux arguments sont séparés par une virgule ; toutefois, l'instrument acceptera comme délimiteur un (ou des) espace(s).

```
2,3
2SP3
2,SP3
```

NOTE

Dans le dernier exemple, l'espace est traité comme un caractère formaté parce qu'il suit la virgule (délimiteur de l'argument).

Format des arguments numériques

L'instrument accepte les nombres suivants comme arguments numériques :

- Les nombres entiers avec ou sans signe (y compris +0 et -0). Les nombres entiers sans signe sont interprétés comme des nombres positifs. Exemples : +1, 2, -1, -10
- Les nombres décimaux avec ou sans signe. Les nombres décimaux sans signes sont interprétés comme des nombres positifs. Exemples : -3.2, +5.0, 1.2

Programmation - DM 5010

- Les nombres à virgule flottante exprimés en notation scientifique. Exemples : +1.0E-2, 1.0E-2, 0.01E+0

L'argument le plus long autorisé est $\pm 3.4028E+38$.

Protocole des messages

Tout message reçu par le DM 5010 est stocké dans la Mémoire Tampon d'Entrée, traité, puis exécuté. Le traitement d'un message consiste en le décodage des commandes, la détection des délimiteurs, et la vérification de la syntaxe. En ce qui concerne les commandes de réglage, l'instrument consigne les modifications indiquées dans la mémoire Réglages en Attente. Si une erreur est détectée en cours de traitement, l'instrument fait passer la ligne SRQ à l'état bas, ignore le reste du message, et réinitialise la mémoire Réglages en Attente. Ceci évite toute condition de fonctionnement incorrecte pouvant résulter de l'exécution partielle des commandes de réglage contenues dans un message.

L'exécution d'un message consiste en l'exécution des actions spécifiées par la (ou les) commande(s) qu'il contient. S'agissant des Commandes de Réglage, ceci signifie la remise à jour des réglages de l'instrument, et leur stockage dans la mémoire tampon Réglages Actuels. Les commandes de réglage sont exécutées par groupes - une série de commandes de réglage est traitée et consignée dans la mémoire Réglages en Attente avant leur exécution. Ceci permet à l'utilisateur de spécifier de nouveaux réglages sans avoir à se préoccuper de la validité d'une séquence particulière. Leur exécution survient lors du traitement de la fin du message par l'instrument, d'une commande d'interrogation en sortie, ou d'une commande d'utilisation contenue dans un message.

Lors du traitement d'une commande d'interrogation en sortie (contenue dans un message), l'instrument exécute toutes les commandes de réglage qui précèdent (remise à jour de ses conditions de fonctionnement). Il exécute alors la commande d'interrogation en extrayant la donnée appropriée et en la plaçant dans la Mémoire Tampon de Sortie. Puis il traite et exécute le reste du message. Lorsque l'instrument est désigné comme Emetteur, cette donnée est transmise au contrôleur.

Lors du traitement d'une commande d'utilisation (contenue dans un message), l'instrument exécute d'abord toutes les commandes de réglages précédentes avant de l'exécuter.

Messages multiples

La Mémoire Tampon d'Entrée a une capacité limitée et un message unique peut être assez long pour la remplir. Dans ce cas, une partie du message est traitée avant que l'appareil accepte une entrée supplémentaire. Durant un traitement de commande, il rejette toute autre donnée (en validant la ligne NRFD) jusqu'à ce que de l'espace soit disponible en mémoire tampon.

L'instrument pourra alors accepter un second message avant que le premier ne soit traité complètement, mais non un troisième (signal NRFD).

Après l'exécution d'une commande d'interrogation de sortie, l'instrument garde la réponse dans sa Mémoire Tampon de Sortie jusqu'à ce qu'il soit désigné comme Emetteur par le contrôleur. S'il reçoit un nouveau message avant la lecture de toute la sortie du précédent, il annule le contenu de la Mémoire Tampon de Sortie avant d'exécuter ce nouveau message. Ceci évite au contrôleur de recevoir des données indésirées issues d'anciens messages.

Autre situation pouvant annuler une sortie : l'exécution d'un long message peut remplir complètement les mémoires tampons d'entrée et de sortie. Dans ce cas, l'instrument ne peut finir l'exécution du message avant que le contrôleur ait lu les données transmises. Mais le contrôleur ne peut lire ces données avant d'avoir fini de transmettre son message. La Mémoire Tampon d'Entrée, étant pleine, rejette le reste du message du contrôleur (signal NRFD). Cette situation suspend l'activité du système, le contrôleur et l'instrument s'attendant réciproquement. Le DM 5010 génère alors un message d'erreur, fait passer la ligne SRQ à l'état bas, et annule le contenu de la Mémoire Tampon de Sortie. Cette action permet au contrôleur de transmettre le reste de son message, puis l'informe de l'exécution du message et de la disparition des autres données en sortie.

Un instrument de la série TM 5000 peut être désigné comme Emetteur sans avoir reçu de message lui spécifiant ce qu'il doit transmettre. Dans ce cas, les instruments d'acquisition (compteurs et multimètres numériques) renvoient une mesure (si elle est prête). Sinon, ils renvoient un message unique sur un octet dont tous les bits sont égaux à 1 (avec une Fin de Message) ; les autres instruments de la série TM 5000 ne renverront que ce message.

Réponse de l'instrument aux messages de l'interface IEEE-488

Les messages de l'interface et leurs effets sur les fonctions de l'interface de l'instrument sont définis dans les normes IEEE 488-1978. Ce paragraphe, qui en décrit les effets sur le fonctionnement de l'appareil, utilise des abréviations de ces normes.

UNL - Unlisten - N'est pas Récepteur (63 avec la ligne ATN)
UNT - Untalk - N'est pas Emetteur (95 avec la ligne ATN)

La commande UNL fait passer le Récepteur à l'état inactif (non adressé) ; l'instrument n'accepte pas de commande du GPIB.

La commande UNT fait passer l'Emetteur à l'état inactif ; l'instrument ne peut transmettre de données sur le GPIB.

Le voyant ADDRESSED est éteint lorsque ces deux fonctions sont à l'état inactif. Il est allumé si l'instrument est adressé soit en tant qu'Emetteur, soit en tant que Récepteur.

IFC - Interface Clear (Initialisation de l'Interface) (broche 9 du GPIB)

Ce message à ligne unique a le même effet que les messages UNT et UNL. Le voyant ADDRESSED (face avant) est éteint.

DCL - Device Clear (Initialisation de l'Instrument) (20 avec la ligne ATN)

Ce message réinitialise les communications entre l'instrument et le Contrôleur. En réponse à ce message, l'instrument annule tout message en entrée et en sortie et toute commande de réglage dans la mémoire tampon Réglages en Attente. Il en est de même pour toute erreur ou tout événement non encore transmis, à l'exception de la Mise en Service. Si la ligne SRQ est à l'état bas (validée) pour une autre raison que la mise en service, elle passe à l'état haut à la réception du message DCL.

SDC - Selected Device Clear (Initialisation Particulière de l'Instrument) (4 avec la ligne ATN)

Ce message exécute la même fonction que DCL ; toutefois, seuls les instruments adressés comme Récepteurs répondent à ce message.

GET - Group Execute Trigger (Déclenchement Simultané de Tous les Instruments par le Contrôleur) (8 avec la ligne ATN)

L'instrument n'exécute cette commande que s'il est adressé comme Récepteur et si la fonction Device Trigger (Déclenchement de l'Instrument par le Contrôleur) a été validée par la commande Device Trigger (DT). Le message <GET> est ignoré et une Demande de Service est générée si la fonction DT est inhibée (DT OFF), si l'instrument est en mode Local, ou si un message est en cours de traitement à la réception de <GET8F.

SPE - Serial Poll Enable (validation de l'appel sélectif) (24 avec la ligne ATN)

SPD - Serial Poll Disable (inhibition de l'appel sélectif) (25 avec la ligne ATN)

Le message SPE valide la génération par l'instrument de mots d'état (en réponse à un appel sélectif en série) lorsqu'il est adressé comme Emetteur (Talk). Le message SPD ramène l'instrument en mode d'utilisation normal (transmission de données issues de la Mémoire Tampon de Sortie).

MLA - My Listen Address (Mon adresse en tant que Récepteur)

MTA - My Talk Address (Mon adresse en tant qu'Emetteur)

Les adresses primaires "Talk" et "Listen" sont déterminées par l'adresse des instruments sur le GPIB (sélectionnée à l'intérieur). L'adresse GPIB actuelle est affichée en face avant lorsque le bouton ID est enfoncé.

Lorsque l'instrument est désigné comme Emetteur ou comme Récepteur, le voyant ADDRESSED en face avant s'allume.

LLO - Local Lockout (ne fonctionne plus en mode Local) (17 avec la ligne ATN)

En réponse à LLO, l'instrument passe à l'état "bloqué" - de LOCS à LWLS ou de REMS à RWLS.

REN - Remote Enable (Commande à Distance)

Si la ligne REN est à l'état bas (validée), l'instrument passe en mode Contrôle à distance (de LOCS à REMS ou de LWLS à RWLS) une fois reçue son adresse Récepteur. Si la ligne REN est à l'état haut (inhibée), l'instrument passe en mode Local (LOCS), et y reste tant que la ligne REN est à l'état haut.

Cette transition REN peut se produire après le début du traitement d'un message. Dans ce cas, l'exécution de celui-ci n'est pas affectée par une transition.

GTL - Go To Local (Contrôle Local) (1 avec la ligne ATN)

Seuls les instruments adressés comme Récepteurs répondent à cette commande en passant en mode Local. Les transitions Contrôle à Distance-Contrôle Local provoquées par cette commande n'affectent pas l'exécution du message en cours de traitement (quand GTL est reçu).

Remote (Contrôle à Distance) - Local Operation (Contrôle Local)

Les lignes qui précèdent décrivent les transitions d'un état à l'autre provoquées par les messages GTL et REN. La plupart des commandes en face avant provoquent une transition entre REMS et LOCS en validant le message "Retour en mode Local" (rtl). Cette transition peut se produire durant l'exécution d'un message ; mais, par opposition aux transitions GTL et REN, elle en affecte l'exécution. Dans ce cas, l'instrument génère une erreur s'il subsiste des commandes de réglage ou d'utilisation non exécutées. Les commandes en face avant n'affectant que l'affichage (telle INST ID) n'ont pas d'incidence sur les états "A distance-Local" - seules les commandes agissant sur les réglages (à l'exception des commandes de déclenchement) génèrent le message rtl. Celui-ci est validé par l'entrée de plusieurs commandes au clavier, et est inhibé après le traitement de ces commandes. Le message rtl prévenant toute transition dans l'état REMS, l'instrument inhibe le message rtl si une séquence de commandes n'a pas été exécutée dans un délai raisonnable (environ 5 à 10 secondes).

L'instrument conserve une copie de ses réglages dans la mémoire tampon Réglages Actuels ; ceux-ci sont remis à jour par tous nouveaux réglages issus de la face avant ou du Contrôleur. De plus, les fonctions de la face avant sont remises à jour pour refléter tout nouveau réglage. Ces réglages ne sont pas affectés par une transition de l'un des quatre états ("A distance - Local") précédemment définis à l'autre. L'indicateur REMOTE s'allume lorsque l'instrument est dans l'état REMS ou RWLS.

Programmation - DM 5010

Local State (LOCS) - (Etat Local)

Les réglages de l'instrument sont contrôlés en face avant par l'opérateur. Seules les commandes du bus n'agissant pas sur les réglages sont exécutées (interrogations) ; toutes les autres commandes du bus (de réglage et d'utilisation) génèrent une erreur car leurs fonctions sont contrôlées en face avant.

Local With Lockout State (LWLS) - (Etat Local avec blocage de l'Etat Local)

L'instrument opère de la même façon qu'en mode LOCS, excepté que le message rtl n'inhibe pas le passage dans l'état RWLS.

Remote State (REMS) - (Etat Commande à Distance)

L'instrument exécute toutes ses commandes. Tout changement d'une commande en face avant (sauf d'une commande de déclenchement) génère un message rtl et provoque le retour en mode Local (LOCS).

Remote With Lockout State (RWLS) - (Contrôle à Distance avec blocage de l'Etat Local)

Identique à REMS excepté que le message rtl est ignoré.

INDICATIONS D'ETATS ET D'ERREURS

En utilisant la fonction Demande de Service (définie dans les normes IEEE-488), l'instrument peut adresser une demande de service au contrôleur. Cette demande de service permet également de signaler qu'un événement (changement d'état ou erreur) est survenu. En réponse à une demande de service, le contrôleur effectue un Appel Sélectif en Série. Chaque instrument renvoie alors un mot d'état (STB) indiquant s'il est, ou non, à l'origine de la demande de service. Ce mot d'état peut également contenir une information (succincte) sur la tâche requise. Le format de cette information est indiqué tableau 3.2.

Lorsque le bit de donnée 8 est présent, le STB contient une information sur l'état de l'instrument qui est fournie par les bits 1 à 4. Le bit 4 indique si le DM 5010 attend un déclenchement. Le bit 3 indique qu'une mesure est disponible.

Parce que le STB convoie une information limitée concernant un événement, les événements sont divisés en deux types : le Mot d'Etat définit le type. Les types d'événements se définissent de la façon suivante :

ERREUR DE COMMANDE Indique que l'instrument a reçu une commande qu'il ne peut comprendre.

ERREUR D'EXECUTION

Indique que l'instrument a reçu une commande qu'il ne peut exécuter. Ceci peut provenir d'arguments erronés, ou de réglages contradictoires.

ERREUR INTERNE

Indique que l'instrument a détecté une condition (matérielle ou logicielle) empêchant une opération.

EVENEMENTS DU SYSTEME

Evénements communs à tous les éléments d'un système (Mise en Service, Requête Utilisateur, etc..).

AVERTISSEMENT INTERNE

Indique que l'instrument a détecté un problème. Il reste opérationnel, mais le problème doit être résolu (ex. : atténuation non étalonnée).

ETAT DE L'INSTRUMENT

Evènement relatif à un instrument particulier.

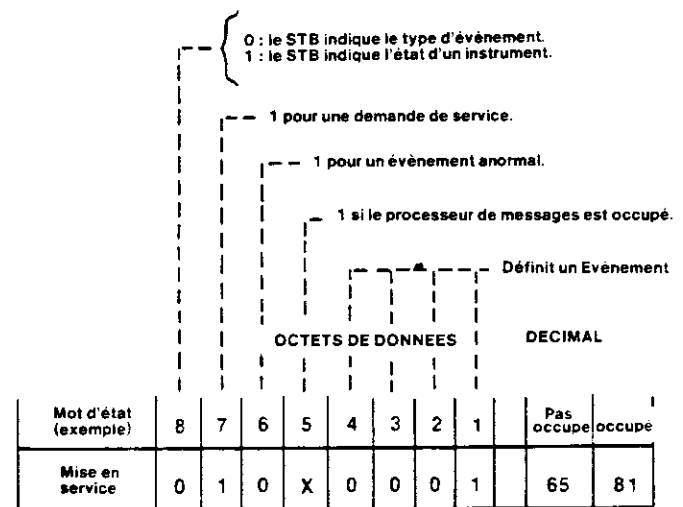

2994-08

Tableau 3.2. Définition des octets du mot d'état

Par une Demande de Service, un instrument a la possibilité de fournir des informations supplémentaires sur de nombreux événements, particulièrement les erreurs signalées dans le Mot d'Etat. Après avoir déterminé d'où est issue la Demande de Service (en examinant le STB), le contrôleur peut requérir ces informations en transmettant l'interrogation ERR?. En réponse, l'instrument renvoie un code définissant l'événement (v. tableau 3.1).

Tableau 3.1.
INDICATIONS D'ERREURS ET D'ETATS

| Evènements anormaux | Réponse à l'interrogation | Appel sélectif ^a en série (décimal) |
|--|---------------------------|--|
| Erreurs de commande | | |
| Préfixe erroné | 101 | 97 |
| Délimiteur de préfixe erroné | 102 | 97 |
| Argument erroné | 103 | 97 |
| Délimiteur d'argument erroné | 104 | 97 |
| Argument non numérique (nombre requis) | 105 | 97 |
| Argument manquant | 106 | 97 |
| Délimiteur de l'unité du message invalide | 107 | 97 |
| Erreurs d'exécution | | |
| Commande non exécutable en mode Local | 201 | 98 |
| Réglages perdus du fait du retour en mode Local (rti) | 202 | 98 |
| Mémoires d'E/S pleines, données de sortie "déchargées" | 203 | 98 |
| Argument hors-gamme | 205 | 98 |
| Déclenchement de groupe ignoré (GET) | 206 | 98 |
| L'instrument n'est pas en position étalonnée | 231 | 98 |
| Au delà des limites d'étalonnage ou de la capacité de la fonction NULL | 232 | 98 |
| Erreurs internes | | |
| Erreur d'interruption | 301 | 99 |
| Erreur du système | 302 | 99 |
| Erreur dans le bloc mathématique | 303 | 99 |
| Temps de conversion erroné | 311 | 99 |
| Temps de réponse en face avant erroné | 317 | 99 |
| Constante d'étalonnage (en ohms) erronée | 318 | 99 |
| Checksum d'étalonnage erroné | 351 | 99 |
| Evènements normaux | | |
| Evènements du système | | |
| Mise en service | 401 | 65 |
| Opération Complète | 402 | 66 |
| Requête de l'utilisateur | 403 | 67 |
| Dépassement de gamme | | |
| 601 | | 102 |
| Etat de l'instrument^b : | | |
| Mesure disponible | 0 | 132 |
| Attend un déclenchement | 0 | 136 |
| Mesure disponible et attend un déclenchement | 0 | 140 |
| < limites | 701 | 193 |
| > limites | 703 | 195 |
| Ni erreur ni évènement | 0 | 128 |

^aSi l'instrument est occupé, il renvoie le nombre indiqué auquel il ajoute 16.

^bLa commande POLL du contrôleur de la Série 4050 renvoie 0 en réponse aux Appels Sélectifs en Série entre 128 et 192

Tableau 3.2
CODES D'ERREUR
VISUALISES EN FACE AVANT

Erreurs d'exécution :

| | |
|-----|--|
| 205 | Argument hors-gamme |
| 231 | L'instrument n'est pas en position étalonnée |
| 232 | Au delà des limites d'étalonnage |

Erreurs internes :

| | |
|-----|--|
| 303 | Erreur dans le bloc mathématique |
| 311 | Temps de conversion erroné |
| 317 | Temps de réponse en face avant erroné |
| 318 | Constante d'étalonnage (en ohms) erronée |
| 340 | RAM erronée |
| 341 | RAM erronée |
| 351 | Checksum d'étalonnage erroné |
| 372 | ROM C000 mal positionnée |
| 373 | ROM D000 mal positionnée |
| 374 | ROM E000 mal positionnée |
| 392 | Checksum de la ROM C000 erroné |
| 393 | Checksum de la ROM D000 erroné |
| 394 | Checksum de la ROM E000 erroné |
| 395 | Checksum de la ROM F000 erroné |
| 521 | Le commutateur d'adresse GPIB (Analyse de signatures) est validé |

Dans le cas de plusieurs évènements, l'instrument maintient la ligne SRQ à l'état bas jusqu'à ce que tous les évènements aient été signalés au contrôleur. Une fois que celui-ci en a pris connaissance (par un Appel Sélectif en Série), chaque évènement est annulé automatiquement. Le message de l'interface Device Clear (DCL) peut être utilisé pour annuler tous les évènements, sauf la Mise en Service.

Certaines commandes valident la transmission d'évènements individuels au Contrôleur et inhibent les Demandes de Service. Par exemple, la commande User Request (USER) permet à l'utilisateur de communiquer l'évènement "Requête de l'utilisateur" à partir de la face avant (bouton INST ID enfoncé). La commande RQS contrôle l'utilisation de demandes de service pour transmettre des évènements au Contrôleur.

RQS OFF inhibe toutes les demandes de service (sauf la Mise en Service). Dans ce mode, l'interrogation ERR? permet au Contrôleur de s'informer des évènements sans exécuter un Appel Sélectif en Série. Il peut émettre cette interrogation à tout instant ; l'instrument lui transmet alors tout évènement en attente d'être communiqué. Le Contrôleur peut annuler tous les évènements, soit en transmettant l'interrogation ERR? jusqu'à ce que le code zéro (0) soit renvoyé, soit par l'intermédiaire du message DCL de l'interface (Mise en Service exceptée).

En mode RQS OFF, le Contrôleur peut exécuter un Appel Sélectif en Série, mais le mot d'état obtenu ne contient que l'indication d'Etat propre à l'appareil. En mode RQS ON, le STB (mot d'état) contient le type de l'évènement. Une interrogation "Erreur" ultérieure renvoie une information supplémentaire sur cet évènement.

; les réponses indiquées peuvent être obtenues à l'aide des instructions WBYTE et RBYTE.

TRANSMISSION DE MESSAGES DE CONTROLE DE L'INTERFACE

Les commandes qui suivent sont utilisées par les contrôleurs de la série 4050 Tektronix et utilisables par les autres contrôleurs.

Les commandes ASCII sont transmises au DM 5010 à l'aide des instructions PRINT. La réception par le Contrôleur des réponses ASCII s'effectue par l'intermédiaire des instructions INPUT.

```
PRINT 16:"SET?"
INPUT 16:AS
```

16 étant l'adresse GPIB du DM 5010 (sélectionnée en usine).

Les messages de contrôle du Bus Interface sont transmis par l'intermédiaire des commandes WBYTE du Contrôleur. Dans les exemples suivants, A et B sont les adresses "Emettre" et "Recevoir". A = 32 plus l'adresse de l'instrument, et B = 64 plus l'adresse de l'instrument.

| | |
|--|---------------|
| Listen (Recevoir) | WBYTE @, A: |
| Unlisten (Ne pas recevoir) | WBYTE @ 63: |
| Talk (Emettre) | WBYTE @ B: |
| Untalk (Ne pas émettre) | WBYTE @ 95: |
| Device clear (DCL) (initialisation de l'instrument) | WBYTE @ 20: |
| Selective device clear (SDC) (initialisation particulière de l'instrument) | WBYTE @ A,4: |
| Go to local (GTL) (retour en mode Local) | WBYTE @ A,1: |
| Remote with lockout (contrôle à distance avec blocage) | WBYTE @ A,17: |
| Local with lockout (blocage du contrôle local) | WBYTE @ 17: |
| Group Execute Trigger (GET) (déclenchement groupé) | WBYTE @ A,8: |
| Serial Poll Enable (Validation de l'appel sélectif en série (SPE)) | WBYTE @ 24: |
| Serial Poll Disable (Inhibition de l'appel sélectif en série (SPD)) | WBYTE @ 25: |

Des informations sur les Contrôleurs de la Série 4050 sont données dans le manuel d'utilisation correspondant.

REGLAGES EFFECTUES A LA MISE EN SERVICE

A la mise en service, le DM 5010 exécute un programme d'auto-test permettant de vérifier le bon fonctionnement des RAMs et des ROMs. Si aucune erreur n'est détectée, l'instrument passe à l'Etat Contrôle Local (LOCS), avec les réglages indiqués au tableau 3.3. La ligne SRQ du GPIB est également validée.

Ces réglages sont également restaurés lors de l'exécution de la commande INIT. La gamme de mesure de la fonction DCV n'est valable que pour le premier affichage, l'instrument se trouvant en mode Sélection de Gamme Automatique.

Tableau 3-3
REGLAGES EXISTANTS A LA MISE SOUS TENSION

| Préfixe | Argument |
|---------|----------|
| AVE | 2 |
| CALC | OFF |
| DBR | 1 |
| DCV | -1.E+3 |
| DIGIT | 4.5 |
| DT | OFF |
| LFR | OFF |
| LIMITS | 0.0 |
| MODE | RUN |
| MONITOR | OFF |
| NULL | 0 |
| OPC | OFF |
| OVER | OFF |
| RATIO | 1.0 |
| RQS | ON |
| SOURCE | FRONT |
| USER | OFF |

TABLE DE CONVERSION ASCII ET IEEE 488 (GPIB)

| BITS | | | | 0 0 0 | | 0 0 1 | | 0 1 0 | | 0 1 1 | | 1 0 0 | | 1 0 1 | | 1 1 0 | | 1 1 1 | | | | | | |
|------|----|----|----|-------|----|-------|---------|-------|-------|-------|-----------------|-------|----|-------|------------|-------|-----|-------|-------|-----|-----|-----|--------------|---|
| B7 | B6 | B5 | B4 | B3 | B2 | B1 | CONTROL | | | | NUMBERS SYMBOLS | | | | UPPER CASE | | | | LOWER | | | | | |
| 0 | 0 | 0 | 0 | 0 | 0 | 0 | 0 | NUL | 20 | DLE | 40 | SP | 60 | 0 | 100 | @ | 120 | P | 140 | ' | 160 | p | | |
| 0 | 0 | 0 | 0 | 1 | 0 | 0 | 1 | SOH | BTLL0 | 21 | DC1 | LL0 | 41 | ! | 61 | 1 | 101 | A | 121 | Q | 141 | a | 161 | q |
| 0 | 0 | 0 | 1 | 0 | 0 | 0 | 2 | STX | DC2 | 22 | " | 42 | " | 62 | 2 | 102 | B | 122 | R | 142 | b | 162 | r | |
| 0 | 0 | 0 | 1 | 1 | 0 | 0 | 3 | ETX | DC3 | 23 | # | 43 | # | 63 | 3 | 103 | C | 123 | S | 143 | c | 163 | s | |
| 0 | 1 | 0 | 0 | 0 | 0 | 0 | 4 | EOT | SDC | 24 | DC4 | DCL | 44 | \$ | 64 | 4 | 104 | D | 124 | T | 144 | d | 164 | t |
| 0 | 1 | 0 | 0 | 1 | 0 | 0 | 5 | ENQ | PPC | 25 | NAK | PPU | 45 | % | 65 | 5 | 105 | E | 125 | U | 145 | e | 165 | u |
| 0 | 1 | 0 | 1 | 0 | 0 | 0 | 6 | ACK | SYN | 26 | & | 46 | & | 66 | 6 | 106 | F | 126 | V | 146 | f | 166 | v | |
| 0 | 1 | 0 | 1 | 1 | 0 | 0 | 7 | BEL | ETB | 27 | ' | 47 | ' | 67 | 7 | 107 | G | 127 | W | 147 | g | 167 | w | |
| 1 | 0 | 0 | 0 | 0 | 0 | 0 | 8 | BS | GET | 30 | CAN | SPE | 50 | (| 70 | 8 | 110 | H | 130 | X | 150 | h | 170 | x |
| 1 | 0 | 0 | 0 | 1 | 0 | 0 | 9 | HT | TCT | 31 | EM | SPD | 51 |) | 71 | 9 | 111 | I | 131 | Y | 151 | i | 171 | y |
| 1 | 0 | 0 | 1 | 0 | 0 | 0 | 10 | LF | A | 32 | SUB | 2A | * | 72 | : | 112 | J | 132 | Z | 152 | j | 172 | z | |
| 1 | 0 | 0 | 1 | 1 | 0 | 0 | 11 | VT | B | 33 | ESC | 2B | + | 73 | ; | 113 | K | 133 | [| 153 | k | 173 | { | |
| 1 | 1 | 0 | 0 | 0 | 0 | 0 | 12 | FF | C | 34 | FS | 2C | , | 74 | < | 114 | L | 134 | \ | 154 | l | 174 | | |
| 1 | 1 | 0 | 0 | 1 | 0 | 0 | 13 | CR | D | 35 | GS | 2D | - | 75 | = | 115 | M | 135 |] | 155 | m | 175 | } | |
| 1 | 1 | 0 | 1 | 0 | 0 | 0 | 14 | SO | E | 36 | RS | 2E | . | 76 | > | 116 | N | 136 | ^ | 156 | n | 176 | ~ | |
| 1 | 1 | 0 | 1 | 1 | 0 | 0 | 15 | SI | F | 37 | US | 2F | / | 77 | ? UNL | 117 | O | 137 | UNT | 157 | 0 | 177 | RUBOUT (DEL) | |

Commandes adressées Adresse "recevoir" Adresse "transmettre" Adresses secondaires ou commandes.

Commandes universelles

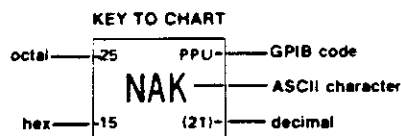

Fig. 3.3. Table de conversion ASCII et IEEE 488 (GPIB)

Programmation - DM 5010

EXEMPLES DE PROGRAMMES

Programmes de Transmission et de Réception pour Contrôleurs Tektronix de la Série 4050.

```
100 REM PROGRAMME DE
    TRANSMISSION/RECEPTION DM 5010
110 REM L'ADRESSE PRIMAIRE DU DM 5010 EST 16
120 INIT
130 ON SRQ THEN 260
140 DIM A$(200)
150 PRINT "ENTRER LE(S) MESSAGE(S): ";
160 INPUT C$
170 PRINT 16:C$
180 REM RECHERCHER LES INTERROGATIONS
190 IF POS(C$,"?",1)<>0 THEN 220
200 REM RECHERCHER 'SEND'
210 IF POS(C$,"SEND",1)$0 THEN 150
220 REM ENTREE ISSUE DE L'INSTRUMENT
230 INPUT 16:A$
240 PRINT A$
250 GO TO 150
260 REM SOUS-PROGRAMME D'APPEL SELECTIF EN
    SERIE
270 POLL X,Y;16
280 PRINT "MOT D'ETAT: ";Y
290 RETURN
```

Ces exemples de programmes sont destinés à aider l'utilisateur à transmettre des commandes au DM 5010 pour la modification de ses réglages et le renvoi des données générées.

Une aide supplémentaire pour le développement de logiciel nécessaire à une application spécifique est fournie dans les manuels Tektronix suivants :

070-3985-00 - GPIB Programming Guide (Guide de Programmation du GPIB). Manuel décrivant les applications de cet instrument dans des systèmes compatibles IEEE-488. Ce manuel contient des instructions et conseils de programmation, ainsi que des exemples de programmes spécifiques.

070-2270-00 - 4051 GPIB Hardware Support Manual (Manuel d'utilisation du GPIB avec le contrôleur 4051). Manuel contenant une description détaillée du fonctionnement du Bus IEEE-488, des différentes opérations sur le Bus, et des circuits de l'interface.

Programme de Transmission et de Réception pour Contrôleurs Tektronix de la Série 4040

```
90 REM PROGRAMME DE
    TRANSMISSION/RECEPTION DM5010
95 REM ADRESSE PRIMAIRE DU DM 5010 $ 16
100 OPEN 1:"GPIB(PRI$16,EOM$<>):"
110 ON SRQ THEN GOSUB 240
115 ENABLE SRQ
120 DIM A$ TO (200)
130 PRINT "ENTRER LA (OU LES)
    COMMANDE(S)/INTERROGATION"
140 INPUT C$
145 IF C$="EX" THEN GOTO 230
150 PRINT 1:C$
160 REM RECHERCHER LES INTERROGATIONS
170 IF POS(C$,"?",1)<>0 THEN GOTO 200
180 IF POS(C$,"SEND",1)$0 THEN GOTO 130
190 REM ENTREE ISSUE DE L'INSTRUMENT
200 INPUT 1:A$
210 PRINT A$
220 GOTO 130
230 STOP
240 POLL SB,P,S;16
250 PRINT "SRQ VUE, MOT D'ETAT: ",SB
260 RETURN
```

070-2058-01 - Programming in Basic (Programmation en Basic).

070-2059-01 - Graphic programming in Basic (Programmation graphique en Basic).

062-5971-01 - 4050-Series programming aids, T1 (Aide à la programmation des contrôleurs de la Série 4050 - logiciel inclus).

062-5972-01 - 4050-Series programming aids, T2 (Aide à la programmation des contrôleurs de la Série 4050 - logiciel inclus).

070-2380-01 - 4907 File manager operators manual (manuel d'utilisation du système de gestion de fichiers 4907).

070-2128-00 - 4924 Users manual (manuel d'utilisation du 4924).

070-1940-01 - 4050-Series graphic system operators manual (manuel d'utilisation des systèmes graphiques de la Série 4050).

070-2056-01 - 4050-Series graphic system reference manual (manuel de référence des systèmes graphiques de la Série 4050).

070-3918-00 - 4041 Operators manual (manuel d'utilisation du 4041).

061-2546-00 - 4041 Programming reference manual (manuel de référence pour la programmation du 4041).

AIDE A LA PROGRAMMATION DU DM 5010

Ces indications, illustrées d'exemples précis, sont destinées à aider l'utilisateur à développer ses propres programmes de contrôle du DM 5010. Les exemples de programmes ont été réalisés à l'aide d'un Contrôleur de la Série 4050 et du DM 5010. Certains exemples utilisent d'autres instruments de la Série TM 5000. Avant d'effectuer la programmation du DM 5010, sélectionner la Fin de Message, l'adresse GPIB, et le mode Emetteur Seulement, à l'aide des commutateurs correspondants. Pour afficher ces réglages en cours d'utilisation, appuyer sur le bouton INST ID. Le nombre affiché est l'adresse primaire GPIB. Le nombre décimal de droite (de l'affichage) s'allume si la Fin de Message sélectionnée est LF/EOI. Le signe "moins" s'allume si le mode Emetteur Seulement est sélectionné. Pour modifier ces réglages internes, s'adresser à un personnel de maintenance qualifié (v. chapitre Maintenance).

Dans les exemples de programmes, la variable D est affectée à l'adresse primaire GPIB du DM 5010 (16 à la livraison). L'utilisation d'une variable alphabétique élimine la nécessité de répéter le numéro d'adresse, et permet de changer aisément celle-ci.

Traitement des Demandes de Service

A la mise en service, le DM 5010 valide la ligne SRQ. La Demande de Service (SRQ) informe le contrôleur de l'interruption de la source d'alimentation durant le déroulement du programme, celle-ci pouvant nuire à sa bonne exécution.

Le DM 5010 peut également valider la ligne SRQ pour d'autres événements (v. tableau 3.1, Indications d'erreurs et d'états). Certains contrôleurs ont la possibilité d'ignorer les Demandes de Service. D'autres doivent les exécuter toutes. Si des Demandes de Service doivent être exécutées dans le programme, penser à valider son interruption.

Programme de traitement des interruptions - programme exécutant les Demandes de Service survenant en cours d'exécution d'un programme. Il se compose essentiellement d'une instruction SRQ ON (en début de programme), et d'un sous-programme d'Appel Sélectif en Série (POLL) (en un point quelconque du programme). A l'occurrence d'une Demande de Service, l'instruction ON SRQ transmet le contrôle du programme au sous-programme POLL. Cette instruction se trouve à la ligne 110 des exemples 1 et 3. Une interruption entraîne donc l'exécution par le contrôleur d'un Appel Sélectif en Série (POLL). Dans une instruction POLL, la première variable renvoie la position des instruments dans la liste des adresses GPIB. La seconde renvoie le Mot d'Etat. Voir l'exemple d'Appel Sélectif (par un seul appareil sur le Bus) à la ligne 1000 de l'Exemple 3. La ligne 400 de l'exemple 4 "interroge" trois instruments sur le Bus en utilisant pour chaque adresse une variable alphabétique. Dans chaque exemple, l'Appel Sélectif

renvoie le Mot d'état de l'instrument à l'origine de la Demande de Service. Les lignes 150, 160, et 170 du programme 9 comprennent un Appel Sélectif en Série utilisant les instructions WBYTE et RBYTE de la Série 4050.

Le sous-programme d'Appel Sélectif en Série peut être étendu au décodage des informations de l'évènement occasionnant la Demande de Service. Dans l'exemple 1, les lignes 510 et 520 annulent le bit "occupé" (busy) du Mot d'Etat. Les lignes 530 à 560 décodent le Mot d'Etat et les lignes 1000 à 7030 affichent sur l'écran du contrôleur le type de l'évènement.

L'exemple 7 utilise la Demande de Service du Moniteur pour détecter les mesures supérieures ou inférieures aux limites définies par la commande LIMITS, ou les dépassements de gamme. Les lignes 1020, 1040, et 1045 décodent le Mot d'Etat et initialisent l'affichage correspondant sur le contrôleur.

La ligne 130 de l'exemple 2 "interroge" (poll) l'instrument à l'adresse 16 pour annuler la Demande de Service de la mise sous tension. La ligne 160 annule toute demande de service ultérieure (RQS OFF). Après la génération de RQS OFF, l'interrogation ERR? peut être insérée dans le programme chaque fois qu'il s'avère nécessaire de déterminer l'état d'un évènement.

Blocage de la face avant

La face avant peut être inhibée de façon à ce que seul le Contrôleur puisse agir sur les réglages de l'instrument. Pour cela, valider la ligne REN (état Vrai) le temps nécessaire. Avec les contrôleurs de la Série 4050, l'instruction RUN valide automatiquement la ligne REN. L'instruction END inhibe la ligne REN. Puis transmettre le message de l'interface LLO (17 en décimal avec la ligne ATN). Avec un contrôleur de la Série 4050, ceci s'effectue à l'aide de l'état WBYTE. Finalement, adresser l'instrument en envoyant un réglage ou une interrogation, en utilisant l'état PRINT D ou envoyer seulement l'adresse "Recevoir" à l'aide de l'instruction WBYTE. Après ces trois étapes, la face avant est bloquée et le demeure jusqu'à ce que le signal REN passe à l'état Faux, ou qu'un message <GTL> (1 en décimal avec la ligne ATN) soit transmis. Voir les lignes 150 et 190 de l'exemple 4. Voir également les lignes 130 et 220 de l'exemple 5.

Utilisation de la commande INIT

Cette commande simplifie le programme du fait qu'elle diminue le nombre des commandes de réglage individuelles. A la ligne 150 de l'exemple 6, le DM 5010 reçoit la commande INIT suivie d'une série de commandes modifiant l'état des réglages initiaux (à la mise en service).

Invalidation d'une mesure en attente

Lorsque le signal entré est modifié par rapport à la mesure en attente, il peut être nécessaire d'invalider

Programmation - DM 5010

celle-ci, du fait qu'elle ne reflète plus les conditions actuelles. Ceci peut être réalisé en envoyant à l'instrument une commande de réglage, qui annulera le contenu de la Mémoire Tampon de sortie. Ou bien en transmettant une mesure au Contrôleur et en ignorant celle-ci.

Les mesures invalides peuvent être évitées en utilisant le mode Déclenché (MODE TRIG) pour contrôler l'occurrence de chaque mesure.

Temps d'établissement

Un temps d'établissement peut être aménagé dans un programme, pour s'assurer de la validité de la mesure renvoyée au contrôleur. Se référer au chapitre Caractéristiques (Commande incrémentielle du Temps de Réponse).

Les lignes 230-250 de l'exemple 4 utilisent une boucle FOR...NEXT pour entrer cinq mesures dans la variable R. A la fin de la boucle, la variable R contient la cinquième mesure.

Les lignes 290-320 de l'exemple 5 effectuent la comparaison entre deux mesures du DM 5010. Si la différence est supérieure à 0,001, la comparaison s'effectue avec une autre mesure. Celle-ci se répète jusqu'à l'obtention de deux mesures pratiquement identiques.

Mesures par déclenchement

Pour déclencher une conversion simple, utiliser le mode Déclenché (MODE TRIG) et initialiser un déclenchement à l'aide de l'une des méthodes suivantes

1. Adresser l'instrument en tant qu'Emetteur. Voir la ligne 180 de l'exemple 2.
2. Transmettre une commande SEND.
3. Transmettre une commande DT TRIG. Puis déclencher le DM 5010 en lui envoyant le message de l'interface <GET> (8 en décimal avec la ligne ATN). Voir les lignes 120 et 5 de l'exemple 9.
4. Si le mode Déclenchement Externe (EXTRIG) est validé, maintenir la ligne P1031-16A de la carte d'isolation à l'état bas durant 10 μ S (max.).

5. Aviser l'opérateur d'appuyer sur le bouton TRIGGERED en face avant.
Pour un déclenchement répétitif (relaxé), utiliser la commande MODE RUN. Si le mode EXTRIG est validé, maintenir la ligne P1031-16A (carte d'isolation) à l'état bas.

Disponibilité d'une mesure

Il n'est pas nécessaire de déterminer si une mesure est disponible lorsque l'instrument est adressé en tant qu'Emetteur ou lors de l'utilisation de la commande SEND pour le renvoi de données. Pour ces deux méthodes, le DM 5010 déclenche une conversion si aucune mesure n'est en attente. Pour les autres méthodes, il existe plusieurs façons de déterminer si une mesure est disponible :

1. Transmettre la commande d'interrogation RDY?. La réponse "1" indique qu'une mesure est prête. Voir la ligne 140 de l'exemple 3.
2. Générer les commandes OPC ON et RQS ON. L'instrument valide la ligne SRQ lorsqu'une mesure est disponible. Voir la ligne 150 de l'exemple 8.
3. Répéter le programme d'Appel Sélectif en Série (POLL) en utilisant les instructions WBYTE, jusqu'à ce que le Mot d'Etat soit 132, 148, 140, ou 156. Voir les lignes 150 et 200 de l'exemple 9.

Utiliser les commandes RDY?, OPC ON, et le programme d'Appel Sélectif dans le cas de plusieurs tâches simultanées.

Transmission de mesures à un Récepteur

Avant le transfert d'une mesure du DM 5010 à un Récepteur sur le Bus GPIB, "adresser" cet instrument en tant que Récepteur. Puis adresser le DM 5010 comme Emetteur pour transmettre les mesures. Les données transmises à un Contrôleur peuvent être lues sous forme d'une chaîne de caractères ou d'une variable numérique. Voir la ligne 180 de l'exemple 2 et la ligne 150 de l'exemple 3.

PROGRAMMIERUNG

Einführung

Dieser Abschnitt des Handbuches informiert über die Programmierung des TEKTRONIX Programmierbaren Digital Multimeters DM 5010 über die IEEE-488 Digital-Schnittstelle. Die IEEE-488 Interface-Funktionszeichen für das DM 5010 sind in Abschnitt 1 aufgelistet. In diesem Handbuch wird die IEEE-488 Digital-Schnittstelle als General Purpose Interface Bus (GPIB) bezeichnet. Die nachstehenden Informationen setzen voraus, daß der Leser mit der GPIB-Kommunikation vertraut ist und einige Erfahrungen mit der Programmierung von Controllern hat. Mitteilungs-Protokolle über den GPIB sind in der Norm IEEE-488-1978, „Standard Digital Interface for Programmable Instrumentation“¹ beschrieben und spezifiziert. TM 5000 Geräte wurden für die Kommunikation mit allen GPIB-kompatiblen Controllern entwickelt, die ASCII Mitteilungen (Befehle) über den GPIB senden und empfangen. Diese Befehle programmieren das Gerät oder fragen Informationen vom Gerät ab.

Die Befehle für programmierbare Geräte der Serie TM 5000 wurden für Kompatibilität unter den Gerätetypen entwickelt. Der gleiche Befehl wird bei verschiedenen Geräten für die Steuerung ähnlicher Funktionen verwendet. Ferner sind die Befehle in Mnemoniken spezifiziert, die sich auf die jeweilige Funktion beziehen. Der Befehl INT z. B. stellt das Gerät auf seinen Einschalt-Zustand ein. Zur weiteren Erleichterung der Programmierung entsprechen die Befehls-Mnemoniken in den meisten Fällen denen auf der Frontplatte.

Die Geräte-Befehle werden in drei Formaten dargestellt:

- Eine Abbildung der Frontplatte – die die Beziehung der Befehle zu den Bedienungselementen auf der Frontplatte zeigt. Siehe Bild 3-1.
- Liste der funktionellen Befehle – eine Liste, die in Funktionsgruppen mit kurzen Beschreibungen aufgeteilt ist.
- Detaillierte Befehlsliste – eine alphabetische Auflistung der Befehle mit vollständiger Beschreibung.

¹ Veröffentlicht durch das Institute of Electrical and Electronics Engineers, Inc., 345 East 47th Street, New York, N. Y. 10017.

Programmierbare Geräte der Serie TM 5000 werden über eine Versorgungseinheit TM 5000 mit dem GPIB verbunden. Der Abschnitt Bedienungsanleitung in diesem Handbuch gibt Hinweise für den Einbau des Gerätes in die Versorgungseinheit. Dieser Abschnitt macht Sie auch mit den Vorsichtsmaßnahmen, den Bedienungselementen auf der Frontplatte und den intern wählbaren Gerätefunktionen vertraut.

Die GPIB Primäradresse für dieses Gerät kann intern durch qualifiziertes Servicepersonal verändert werden. Bei Versand ist das DM 5010 auf die Adresse mit dem Dezimaläquivalent 16 eingestellt. Auch das Endezeichen kann intern durch qualifiziertes Servicepersonal ausgewählt werden. Endezeichen werden in diesem Handbuch im Abschnitt „Mitteilungen und Kommunikationsprotokoll“ beschrieben. Bei Versand von TM 5000 Geräten ist dieses Endezeichen auf EOI ONLY eingestellt. Hinweise für qualifiziertes Servicepersonal, wo und wie die Einstellung erfolgt, sind in diesem Handbuch im Abschnitt Wartung enthalten. Eindrücken der Taste INST ID veranlaßt das Gerät seine gewählte GPIB-Primäradresse darzustellen; der Dezimalpunkt ganz rechts leuchtet auf, wenn das gewählte Endezeichen LF/EOI ist. Das Minuszeichen leuchtet auf, wenn die Betriebsart Talk Only eingeschaltet ist.

Betriebsart Talk Only

In der Betriebsart Talk Only kann das DM 5010 über den GPIB unter lokaler Steuerung Daten an einen Hörer (Listener) senden. Für die Wahl dieser Betriebsart wird ein interner Schalter auf die Stellung Talk Only gesetzt. Hinweise dazu findet qualifiziertes Servicepersonal im Abschnitt Wartung.

In der Betriebsart Talk Only beginnt das DM 5010 mit dem Senden von Meßdaten wenn auf der Frontplatte die Taste INST ID gedrückt wird; es stoppt das Senden von Daten wenn auf der Frontplatte die Taste CLEAR gedrückt wird. Wird CLEAR während der Übertragung eines Meßergebnisses gedrückt, stoppt das Gerät erst nach dessen vollständiger Übertragung. Das Lämpchen ADDRESSED bleibt erleuchtet, bis die Übertragung der letzten Ablesung beendet ist.

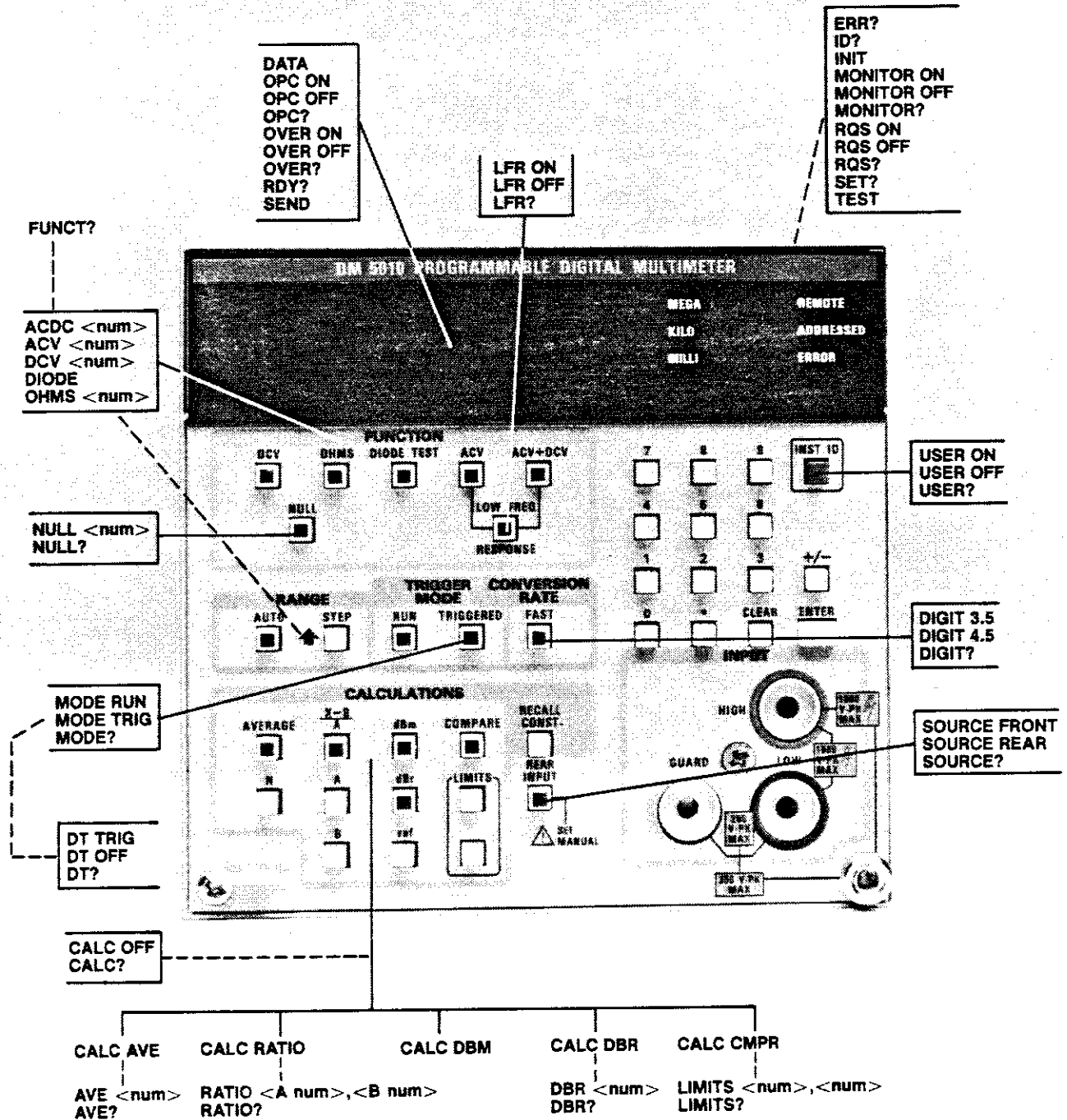

2994-07

Bild 3-1 Gerätebefehle und ihre Beziehung zu den Bedienelementen auf der Frontplatte.

BEFEHLE

Das Gerät wird über die Bedienungselemente auf der Frontplatte oder über Befehle vom Controller gesteuert. Es gibt drei Befehlsarten:

Einstell-Befehle – steuern die Einstellung des Gerätes.

Abfrage-Befehle – fragen nach Daten.

Betriebs-Befehle – veranlassen eine bestimmte Tätigkeit.



Vorsicht bei der Verwendung von weniger Zeichen als im abgekürzten Kopfteil oder Argument enthalten sind. Falsche Ergebnisse und Beschädigungen können auftreten wenn diese Daten an das falsche Gerät gesendet werden.

Ist das Gerät auf Fernbedienung eingestellt, werden alle Befehle beantwortet und ausgeführt. Bei Eigenbedienung, erzeugen „Einstellungs-“ und „Betriebs-Befehle“ Fehler, da die Gerätefunktionen über die Bedienungselemente auf der Frontplatte gesteuert werden; nur „Abfrage-Befehle“ werden beantwortet.

Jeder Befehl beginnt mit einem Kopfteil – einem Wort das die jeweilige Funktion beschreibt. Viele Befehle müssen durch ein Argument nach dem Kopfteil ergänzt werden – einem Wort oder einer Zahl, die die gewünschte Funktion näher beschreibt.



Wenn das Gerät in der Betriebsart AUTO arbeitet, soll die Eingangsspannung nicht wiederholt zwischen einem niedrigen Wert ($< 200 \text{ mV}_S$) und einem höheren Wert ($> 200 \text{ V}_S$) hin und her geschaltet werden. Für wiederholte Messungen, die zwischen den Spannungsextremen alternieren, verwenden Sie vor Erhöhung der Eingangsspannung zur Wahl eines entsprechenden höheren Bereichs die Betriebsart STEP, da sonst zeitweise Ungenauigkeiten bei Messungen im 200 mV Bereich auftreten können.

LISTE DER FUNKTIONELLEN BEFEHLE

GERÄTE BEFEHLE

Funktions-Befehle

- ACDC <num> – Stellt ACV + DCV Funktion und Bereich ein.
- ACV <num> – Stellt ACV Funktion und Bereich ein.
- DCV <num> – Stellt DCV Funktion und Bereich ein.
- DIODE – Stellt DIODE TEST Funktion ein.
- FUNCT? – Abfrage nach Funktion und Bereich.
- LFR ON – Gibt die Funktion LOW FREQ RESPONSE frei.
- LFR OFF – Sperrt die Funktion LOW FREQ RESPONSE.
- LFR? – Abfrage nach LFR ON oder LFR OFF.
- NULL <num> – Gibt die Funktion NULL und den Offsetwert frei.
- NULL? – Abfrage nach NULL Offsetwert.
- OHMS <num> – Stellt OHMS Funktion und Bereich ein.

Trigger-Befehle

- MODE RUN – Gibt die Triggerbetriebsart RUN frei.
- MODE TRIG – Gibt die Triggerbetriebsart TRIGGERED frei.
- MODE? – Abfrage nach MODE RUN oder MODE TRIG!
- RDY? – Abfrage nach RDY 1, wenn eine Messung beendet ist; RDY 0, wenn eine Messung durchgeführt wird oder auf Triggerrung wartet.
- DIGIT 3,5 – Gibt die Übertragungsrate FAST frei.
- DIGIT 4,5 – Gibt die normale Übertragungsrate frei.
- DIGIT? – Abfrage nach DIGIT 3,5 oder DIGIT 4,5.

Berechnungs-Befehle

- AVE <num> – Stellt den Wert der Konstanten N ein.
- AVE? – Abfrage nach dem Wert der Konstanten N.
- CALC AVE – Gibt die AVERAGE Berechnung frei.
- CALC CMPR – Gibt die COMPARE Berechnung frei.
- CALC DBM – Gibt die dBm Berechnung frei.
- CALC DBR – Gibt die dBr Berechnung frei.

Programmierung – DM 5010

- CALC RATIO – Gibt die X-B/A Berechnung frei.
- CALC OFF – Sperrt alle Berechnungen.
- CALC? – Abfrage nach CALC OFF oder der freigegebenen Berechnungsart.
- DBR<num> – Stellt den Wert der Betriebskonstanten ein.
- DBR? – Abfrage nach dem Wert der Bezugskonstanten.
- LIMITS? <num>, <num> – Stellt die Werte der Konstanten LIMITS ein.
- LIMITS? – Abfrage nach den Werten der Konstanten LIMITS.
- MONITOR ON – Gibt SRQ frei wenn die Messung die LIMITS Konstanten übersteigt.
- MONITOR OFF – Sperrt SRQ wenn die Messung die LIMITS Konstanten übersteigt.
- MONITOR? – Abfrage nach MONITOR ON oder MONITOR OFF.
- RATIO <num>, <num> – Stellt die Werte der Konstanten A und B ein.
- RATIO? – Abfrage nach den Werten der Konstanten A und B.

EINGANG/AUSGANGS-BEFEHLE

- DATA – Ausgangsdaten werden durch MONITOR SRQ gespeichert.
- SEND – Ausgangsdaten im Ausgangspuffer; triggert falls erforderlich.
- SOURCE REAR – Wählt den rückseitigen Interface-Eingangsanschluß.
- SOURCE FRONT – Wählt den Eingangsanschluß auf der Frontplatte.
- SOURCE? – Abfrage nach SOURCE FRONT oder SOURCE REAR.

SYSTEM-BEFEHLE

- DT TRIG – Gibt die Geräte-Triggerfunktion frei. Das Gerät triggert nach der Interface-Mitteilung <GET>.
- DT OFF – Sperrt die Geräte-Triggerfunktion.
- DT? – Abfrage nach DT TRIG oder DT OFF.
- ERR? – Abfrage nach dem Fehlercode.
- ID? – Abfrage nach Geräte-Identifikation und Firmware Version.
- INIT – Stellt auf die Einschalt-Bedingungen ein.
- SET? – Abfrage nach den Geräte-Einstellungen.
- TEST – Zeigt 0 bei richtiger, 351 bei unrichtiger Kalibrierungs-Prüfsumme an.

STATUS-BEFEHLE

- OPC ON – Gibt die Bedienungsabfrage nach OPERATION COMPLETE frei.
- OPC OFF – Sperrt die Bedienungsabfrage nach OPERATION COMPLETE.
- OPC? – Abfrage nach OPC ON oder OPC OFF.
- OVER ON – Gibt die Bedienungsabfrage nach Überschreiten des Bereichs frei.
- OVER OFF – Sperrt die Bedienungsabfrage nach Überschreiten des Bereichs.
- OVER? – Abfrage nach OVER ON oder OVER OFF.
- RQS ON – Gibt die Bedienungsabfragen (SRQ) frei.
- RQS OFF – Sperrt die Bedienungsabfragen (SRQ).
- RQS? – Abfrage nach RQS ON oder RQS OFF.
- USER ON – Gibt SRQ frei wenn die Taste ID gedrückt wird.
- USER OFF – Sperrt SRQ wenn die Taste ID gedrückt wird.
- USER? – Abfrage nach USER ON oder USER OFF.

DETAILLIERTE BEFEHLSLISTE

ACDC (AC und DC Spannungsfunktionen)

Art:
Einstellung

Einstellsyntax:
ACDC <number>
ACD <number>
ACDC

| Beispiele: | Gewählter Bereich |
|------------|---------------------|
| ACDC 2 | 2 V |
| ACDC, 9 | 2 V |
| ACDC - 200 | 700 V, AUTO-Bereich |
| ACD | 700 V, AUTO-Bereich |
| ACD 0 | 700 V, AUTO-Bereich |

Beschreibung:

Das Kopfteil wählt ACD + DCV Funktion; das Argument wählt einen fixierten Bereich oder den AUTO-Bereich. Das Format für numerische Argumente wird im hinteren Teil dieses Abschnittes beschrieben. Das Argument kann jeder Wert ≤ 700 sein; das Gerät rundet jedoch das Argument für den nächsten Bereich auf. Zum Beispiel für ein Argument 0,9 wählt das Gerät den Bereich 2 V.

Wenn das Argument weggelassen wird oder sein Wert weniger als 0 ist, geht das Gerät automatisch die Bereiche durch, beginnend mit dem höchsten Bereich.

Wenn das Argument über dem höchsten Bereich liegt, erzeugt das Gerät einen Befehlsfehler (und gibt bei RQS ON ein SRQ aus).

- Bereiche
- 200 mV
 - 2 V
 - 20 V
 - 200 V
 - 700 V

ACV (AC Spannungsfunktion)

Art:
Einstellung

Einstellsyntax:
ACV <number>
ACV

| Beispiele: | Gewählter Bereich: |
|------------|---------------------|
| ACV 18 | 20 V |
| ACV 2 | 2 V |
| ACV - 200 | 700 V, AUTO-Bereich |
| ACV | 700 V, AUTO-Bereich |

Beschreibung:

Das Kopfteil wählt die ACV Funktion; das Argument wählt einen fixierten Bereich oder den AUTO-Bereich. Das Format für numerische Argumente wird im hinteren Teil dieses Abschnittes beschrieben. Das Argument kann jeder Wert sein; das Gerät rundet jedoch das Argument für den nächsten Bereich auf. Zum Beispiel für das Argument 18 wählt das Gerät den 20 V Bereich.

Wenn das Argument weggelassen wird oder sein Wert weniger als 0 ist, geht das Gerät automatisch die Bereiche durch, beginnend mit dem höchsten Bereich.

Wenn das Argument über dem höchsten Bereich liegt, erzeugt das Gerät einen Befehlsfehler (und gibt bei RQS ON ein SRQ aus).

- Bereiche:
- 200 mV
 - 2 V
 - 20 V
 - 200 V
 - 700 V

AVE (Mittelwert)

Art:

Einstellung oder Abfrage

Einstellsyntax:

AVE <number>
AVG <number>

Beispiel:

AVE 6
AVE 2
AVG 10

Abfragesyntax:

AVE?
AVG?

Abfrage-Antwort:

AVE <number>

Beschreibung:

Dieser Befehl spezifiziert die Anzahl der Messungen für die AVERAGE (Mittelwert) Berechnung. (Entspricht der Einstellung des Wertes für die Konstante N auf der Frontplatte). Siehe CALC AVE. Das Argument kann jede Zahl von 1 bis 19999 sein. Das Gerät rundet das Argument auf ganze Zahlen ab.

CALC (Berechnung)

Art:

Einstellung oder Abfrage

Einstellsyntax:

CALC <argument>
 CALC <argument>, <argument>

Argumente:

AVE oder AVG
 CMPR oder COMP
 DBM
 DBR
 RATIO
 OFF

Beispiele:

CALC OFF
 CALC AVE
 CALC AVE, DBM
 CALC RATIO, AVE, DBR

Abfragesyntax:

CALC?

Abfrage-Antwort:

CALC OFF; oder Liste der freigegebenen Berechnung(en).

Beschreibung:

Wenn das Gerät einen CALC Befehl empfängt, schaltet es alle Berechnungen ab mit Ausnahme derjenigen, die hinter dem CALC Kopfteil stehen. Übersteigt das Ergebnis einer Berechnung die Fähigkeiten der Recheneinheit ($\pm 3,4028E+38$), erzeugt das Gerät einen Recheneinheit-Fehler (303).

- CALC AVE oder CALC AVG gibt die AVERAGE Berechnung frei. Das Gerät berechnet den Mittelwert aus einer Reihe von Messungen. Die Anzahl der Messungen wird mit dem Befehl AVE <number> eingestellt.

Eine Triggerung erzeugt genug Ablesungen für ein Mittelwtergebnis. Wird für eine Messung in einer Folge der Bereich überschritten, wird die AVE Berechnung unterbrochen.

Wenn LFR auch freigegeben ist, wird die mit dem Befehl AVE <number> eingestellte Anzahl der Messungen mit 4 multipliziert.

- CALC CMPR oder CALC COMP gibt die COMPARE Berechnung frei. Das Gerät vergleicht den Eingang mit den durch den Befehl LIMITS eingestellten Werten. Der Text zu den nachstehenden Befehlen gibt an, welcher Ausgangsvergleich daraus resultiert:

SEND – zeigt 1., 2., oder 3. für LO, PASS, oder HI an; bei Bereichsüberschreitung + 1E+99; oder – 1E+99.

DATA – zeigt einen Meßwert außerhalb der Grenzbereiche an.

- CALC DBM gibt die dBm Berechnung frei und sperrt die dBr Berechnung. Das Gerät berechnet das Leistungsverhältnis der Eingangsspannung, bezogen auf 1 mW in 600 Ohm (0,7746 V).

$$dBm = 20 \log_{10} \left| \frac{x}{\sqrt{6}} \right|$$

- CACLC DBR gibt die DBR Berechnung frei und sperrt die dBm Berechnung. Das DM 5010 berechnet das logarithmische Verhältnis des Eingangs zu dem mit dem Befehl DBR <number> eingestellten Wert.

$$dBr = 20 \log_{10} \left| \frac{x}{ref} \right|$$

- CALC RATIO gibt die X-B/A Berechnung frei, wobei X die Messung, B ein Offsetwert und A der Skalierungsfaktor ist. Die Werte von A und B werden mit dem Befehl RATIO eingestellt.
- CALC OFF sperrt alle Berechnungen.

DATA

Art:

Ausgabe

Syntax:

DATA

Antwort:

DATA <number>;
oder
DATA $\pm 1.E+99$; (bei Bereichsüberschreitung)

Beschreibung:

Auf diesen Befehl erfolgt eine der nachstehend angegebenen Antworten. Er löst keine Übertragung aus und wartet nicht auf eine neue Messung, wie es der Befehl SEND tut.

1. Nach dem Einschalten wird 0 angezeigt, bis eine Messung zur Verfügung steht.

2. Wenn ein MONITOR SRQ ausgegeben wurde, zeigt DATA die Messung an, die das SRQ veranlaßt hat.

3. Wenn keine der vorstehenden Bedingungen gültig ist, zeigt DATA die letzte Messung an. DATA zeigt die gleiche Ablesung an, bis die nächste Übertragung ausgelöst wird und eine neue Ablesung zur Verfügung steht.

DATA kann für eine Messung eine höhere Auflösung angeben als sie auf der Frontplatte dargestellt oder durch den Befehl SEND angezeigt wird.

DBR

Art:

Einstellung oder Abfrage

Einstellsyntax:

DBR <number>

Beispiel:

DBR 1
DBR .707
DBR 2E-3

Abfragesyntax:

DBR?

Abfrage-Antwort:

DBR <number>;

Beschreibung:

Dieses Befehlsargument stellt den Wert der Konstanten ein, die für den Befehl CALC DBR verwendet wird. Er entspricht der Einstellung des Konstantenwertes auf der Frontplatte. Das Argument kann jede Zahl außer 0 sein.

DCV (DC Spannungsfunktion)

Art:

Einstellung

Einstellsyntax:

DCV <number>
DCV

Beispiele:

Gewählter Bereich

| | |
|------------|----------------------|
| DCV 1.5 | 2 V |
| DCV | 1000 V, AUTO-Bereich |
| DVV -1.E+3 | 1000 V, AUTO-Bereich |

Beschreibung:

Das Kopfteil wählt die DCV Funktion; das Argument wählt einen fixierten Spannungsbereich. Das Format für numerische Argumente wird im hinteren Teil dieses Abschnittes beschrieben. Das Argument kann jeder Wert sein; das Gerät rundet jedoch das Argument auf den nächst höheren Bereich auf. Zum Beispiel für das Argument 1.5 wählt das Gerät den 2 V Bereich.

Wenn das Argument weggelassen wird oder sein Wert weniger als 0 ist, geht das Gerät automatisch die Bereiche durch, beginnend mit dem höchsten Bereich.

Wenn das Argument über dem höchsten Bereich liegt, erzeugt das Gerät einen Befehlsfehler (und gibt bei RQS ON ein SRQ aus).

Bereiche:

200 mV
2 V
20 V
200 V
1000 V

DIGIT (Digitale Auflösung)

Art:

Einstellung oder Abfrage

Einstellsyntax:

DIGIT 3.5
DIGIT 4.5
DIG 3.5
DIG 4.5

Abfragesyntax:

DIGIT?
DIG?

Abfrage-Antwort:

DIGIT 3.5;
DIGIT 4.5;

Beschreibung:

Dieser Befehl wählt die Übertragungsrate. Das Argument 3.5 stellt die FAST Übertragungsrate ein (3.5 Stellen Auflösung). Bei den Spannungsfunktionen benötigt eine Messung etwa 35 ms, bei der Ohm-Funktion etwa 130 ms.

Das Argument 4.5 stellt die normale Übertragungsrate ein (4.5 Stellen Auflösung). Bei den Spannungsfunktionen benötigt eine Messung etwa 310 ms, bei der Ohm-Funktion etwa 600 ms.

DIODE (Diodentest)

Art:

Einstellung

Einstellsyntax:

DIODE
DIO

Beschreibung:

Dieser Befehl wählt die Funktion DIODE TEST. Ein Argument wird nicht akzeptiert.

DT (Gerätetrigger)

Art:

Einstellung oder Abfrage

Einstellsyntax:

DT TRIG
DT OFF

Abfragesyntax:

DT?

Abfrage-Antwort:

DT TRIG;
DT OFF;

Beschreibung:

Mit diesem Befehl wird die Geräte-Triggerfunktion gesperrt oder freigegeben. Wenn die Gerätetriggerung freigegeben ist, löst die IEEE 488 Interface-Mitteilung <GET> eine Triggerung aus.

Wenn <GET> empfangen wird während der Mitteilungs-Prozessor arbeitet oder wenn DT OFF ist erzeugt das Gerät einen Fehler der anzeigt, daß die Mitteilung <GET> ignoriert wurde.

ERR? (Fehler)

Art:

Abfrage

Abfragesyntax:

ERR?

Abfrage-Antwort:

ERR_{sp sp} <number>

Beispiel:

ERR_{sp sp} 401; (eingeschaltet)

Beschreibung:

Die Abfrage ERROR wird verwendet, um Informationen über den Status des Gerätes zu erhalten.

Auf die Abfrage ERROR wird ein Code dargestellt der anzeigt, welches Ereignis ein SRQ veranlaßt hat. Weitere Informationen finden Sie im Status- und Fehlerbericht.

FUNCT? (Funktion)

Art:

Abfrage

Abfragesyntax:

FUNCT?
FUNC?

Abfrage-Antwort Beispiele:

DCV 2.;
ACV20.;
DIODE;
ACDC 200.;
OHMS -2.E+6;

Beschreibung:

Auf diesen Befehl wird die derzeitige Meßfunktion angezeigt. Das Argument spezifiziert den jeweils verwendeten Bereich. Bei AUTO-Bereich wird ein negatives Argument angezeigt.

ID?

Art:

Abfrage

Abfragesyntax:

ID?

Abfrage-Antwort:

ID TEK/DM5010,V79.1Fxx;

Beschreibung:

Auf die Abfrage ID? wird die o. g. Antwort angezeigt.

TEK/DM5010 – Identifiziert das Gerät,
Hersteller und Typ.

V79.1 – Identifiziert die Art der Tektronix Codes und
Formate, denen das Gerät entspricht.

Fxx – Identifiziert die Firmenversion des Gerätes.

INIT

Art:

Betrieb

Syntax:

INIT

Beschreibung:

Dieser Befehl stellt die Gerätefunktionen auf Ihre
Einschaltbedingungen zurück, wie sie in Tabelle 3-3
angegeben sind.

LFR

Art:

Einstellung oder Abfrage

Einstellsyntax:

LFR ON
LFR OFF

Abfragesyntax:

LFR?

Abfrage-Antwort:

LFR ON;
LFR OFF;

Beschreibung:

Mit diesem Befehl wird die Funktion LOW FREQ RESPONSE gesperrt oder freigegeben (wird mit den Funktionen ACV und ACV+DCV verwendet). Wenn freigegeben, berechnet das Gerät den Mittelwert aus vier Messungen.

Wenn CALC AVE auch freigegeben ist, wird die mit dem Befehl AVE <num> eingestellte Anzahl der Messungen mit 4 multipliziert.

LIMITS

Art:

Einstellung oder Abfrage

Einstellsyntax:

LIMITS <number>, <number>
LIM <number>, <number>

Beispiel:

LIMITS 3.2, -2
LIMITS -1, -6.5
LIM 6, 1

Abfragesyntax:

LIMITS?
LIM?

Abfrage-Antwort:

LIMITS <number>, <number>;

Beschreibung:

Die Argumente für diesen Befehl stellen die Grenzwerte ein, die für die COMPARE Berechnung und das MONITOR SRQ verwendet werden. Das erste Argument stellt den Grenzwert ein, welcher der oberen Taste LIMITS auf der Frontplatte entspricht; das zweite Argument stellt den Konstantenwert ein, welcher der unteren Taste LIMITS entspricht.

MODE

Art:

Einstellung oder Abfrage

Einstellsyntax:

MODE RUN
MODE TRIG
MOD RUN
MOD TRIG

Abfragesyntax:

MODE?
MOD?

Abfrage-Antwort:

MODE RUN;
MODE TRIG;

Beschreibung:

Dieser Befehl wählt die Trigger-Betriebsart. Das Argument RUN stellt die Trigger-Betriebsart RUN (freilaufend) ein.

Das Argument TRIG stellt die Betriebsart TRIGGERED ein. In dieser Betriebsart erfolgt nach Empfang einer der folgenden Mitteilungen eine Triggerung:

- Einem „SEND“ Befehl.
- Einer Interface Mitteilung <GET> (nur wenn DT freigegeben ist).
- My Talk Address (MTA) mit nicht spezifiziertem Ausgang (kein Abfrage-Befehl).
- EXTRIG rückseitige Interface-Triggerung (erfordert Einbau einer internen Überbrückung – siehe Abschnitt Wartung). Für eine einzelne Triggerung muß diese Leitung zwischen 0,5 und 10 µsec gehalten werden. Wird sie über einen längeren Zeitraum niedrig gehalten, löst das Gerät Mehrfachmessungen aus.

Wenn in der Betriebsart MODE TRIG und während das Gerät in AUTO-Bereich arbeitet ein Über- oder Unterschreiten des Bereichs vorkommt, ändert das Gerät den Bereich und führt eine weitere Messung aus.

MONITOR

Art:

Einstellung oder Abfrage

Einstellsyntax:

MONITOR ON
MONITOR OFF
MON ON
MON OFF

Abfragesyntax:

MONITOR?
MON?

Abfrage-Antwort:

MONITOR ON;
MONITOR OFF;

Beschreibung:

Mit diesem Befehl wird das MONITOR SRQ gesperrt oder freigegeben. Ist MONITOR SRQ freigegeben, speichert das Gerät die erste Messung außerhalb der Grenzwerte (die mit dem Befehl LIMITS eingestellt wurden) und generiert ein SRQ. Für nachfolgende Messungen (außerhalb der Grenzwerte) werden keine SRQ's erzeugt bis die Bedienungsabfrage erledigt ist und die Messung in Beantwortung des Befehls DATA an den Controller berichtet wurde.

Wenn das Gerät bei MON ON den Bereich überschreitet, gibt es eine Fehlermeldung aus, auch wenn OVER OFF ist.

NULL

Art:

Einstellung oder Abfrage

Einstellsyntax:

NULL <number>

Beispiele:

NULL.2
NULL 0

Abfragesyntax:

NULL?

Abfrage-Antwort:

NULL <number>

Beschreibung:

Dieser Befehl gibt die Funktion NULL frei; das Argument (in Volt oder Ohm) gibt den Wert des Offset an. Dieser Wert kann jede Zahl bis zu 100% des Bereichs sein.

Die Funktion NULL ist gesperrt, wenn die Meßfunktion geändert wird oder das Argument 0 ist. (Die Änderung der Meßfunktion stellt auch das Argument auf 0.)

WARNUNG

Wenn die NULL Funktion freigegeben ist, kann es vorkommen, daß die Messung nicht den an die Eingangsanschlüsse angelegten Spannungswert anzeigt.

OHMS

Art:

Einstellung

Einstellsyntax:

OHMS <number>
OHMS

Beispiele:

| | |
|------------|---------------------|
| OHMS | 20 MΩ, AUTO-Bereich |
| OHMS 100 | 200 Ω |
| OHMS -2E+7 | 20 MΩ, AUTO-Bereich |
| OHMS 1E+4 | 20 kΩ |

Gewählter Bereich:

Beschreibung:

Das Kopfteil wählt die Funktion OHMS; das Argument wählt den Bereich. Das Format für numerische Argumente wird im hinteren Teil dieses Abschnittes beschrieben. Das Argument kann jeder Wert sein; das Gerät rundet jedoch das Argument auf den nächst höheren Bereich auf. Zum Beispiel für das Argument 100 wählt das Gerät den Bereich 200 Ω.

Wenn das Argument weggelassen wird oder sein Wert weniger als 0 ist, geht das Gerät automatisch die Bereiche durch, beginnend mit dem höchsten Bereich.

Wenn das Argument über dem höchsten Bereich liegt, erzeugt das Gerät einen Befehlsfehler (und gibt bei RQS ON ein SRQ aus).

Bereiche:

200 Ω
2 kΩ
20 kΩ
200 kΩ
2 MΩ
20 MΩ

OPC (Operation Complete)

Art:

Einstellung oder Abfrage

Einstellsyntax:

OPC ON
OPC OFF

Abfragesyntax:

OPC?

Abfrage-Antwort:

OPC ON;
OPC OFF;

Beschreibung:

Mit diesem Befehl wird die Bedienungsabfrage Operation Complete gesperrt oder freigegeben. Wenn freigegeben und RQS ist ON, gibt das Gerät ein SRQ aus, wenn eine neue Messung zur Verfügung steht.

OVER

Art:

Einstellung oder Abfrage

Einstellsyntax:

OVER ON
OVER OFF

Abfragesyntax:

OVER?

Abfrage-Antwort:

OVER ON;
OVER OFF;

Beschreibung:

Mit diesem Befehl wird die Bedienungsabfrage für Bereichsüberschreitung gesperrt oder freigegeben. Wenn freigegeben und RQS ist ON, gibt das Gerät ein SRQ aus, wenn es eine Messung außerhalb des Bereichs durchführt.

Bei OVER OFF gibt das Gerät zur Anzeige einer Bereichsüberschreitung $\pm 1.E+99$ aus (es gibt kein SRQ aus).

RATIO

Art:

Einstellung oder Abfrage

Einstellsyntax:

RATIO <number>, <number>

Beispiel:

RATIO 100, 15
RATIO 10, 2

Abfragesyntax:

RATIO?

Abfrage-Antwort:

RATIO <number>, <number>;

Beschreibung:

Die Argumente zu diesem Befehl stellen den Offsetwert und den Skalierungsfaktor für die X-B/A Berechnung ein. Siehe CALC RATIO. Das erste Argument stellt den Wert des Skalierungsfaktors ein (Taste A auf der Frontplatte); das zweite stellt den Offsetwert ein (Taste B auf der Frontplatte). Die Argumente können jede Zahl sein, nur der Skalierungsfaktor kann nicht 0 sein.

RDY?

Art:

Abfrage

Abfragesyntax:

RDY?

Abfrage-Antwort:

RDY_{SP} SP0;
RDY_{SP} SP1;

Beschreibung:

Wenn eine Messung durchgeführt wird oder das Gerät auf eine Triggerung wartet, wird auf diesen Befehl RDY 0 angezeigt. RDY 1 zeigt an, daß Daten zur Verfügung stehen.

RQS

Art:

Einstellung oder Abfrage

Einstellsyntax:

RQS ON
RQS OFF

Abfragesyntax:

RQS?

Abfrage-Antwort:

RQS ON;
RQS OFF;

Beschreibung

Dieser Befehl gibt das Gerät für die Ausgabe von Bedienungsabfragen frei. Das Argument OFF sperrt alle Bedienungsabfragen. Weitere Informationen finden Sie im Abschnitt Status- und Fehlerbericht.

SEND

Art:

Ausgang

Syntax:

SEND
SEN

Antwort:

<number>; (kein Kopfteil)

Beispiel:

$\pm 1.E+99$;; (Bereichsüberschreitung)
 $+3.2E+3$;;

Beschreibung:

Dieser Befehl veranlaßt das Gerät die letzte Messung auszugeben. Ist keine Messung verfügbar, löst das Gerät eine Messung aus und gibt sie dann aus.

Wenn die Berechnung COMPARE freigegeben ist, (CALC CMPR) zeigt das Gerät mit einer der nachstehenden Zahlen die Beziehung zwischen dem Eingang und den mit dem Befehl LIMITS eingestellten Grenzwerten an:

3.; Wenn der Eingang über beiden Grenzwerten liegt.

2.; Wenn der Eingang zwischen den Grenzwerten liegt oder gleich einem der Grenzwerte ist.

1.; Wenn der Eingang unter beiden Grenzwerten liegt.

$+1.E+99$;; oder $-1.E+99$;; bei Bereichsüberschreitung.

SET?

Art:

Abfrage

Abfragesyntax:

SET?

Abfrage-Antwortbeispiel (Einschalt-Einstellungen):

DCV -1.E+3; AVE 2; RATIO 1. 0.; DBR 1.; LIMITS 0.,
0.; CALC OFF; NULL 0.; DIGIT 4.5; LFR OFF; MODE
RUN; SOURCE FRONT; DT OFF; MONITOR OFF; OPC
OFF; OVER OFF; USER OFF; RQS ON;

Beschreibung:

Auf diesen Befehl werden die derzeitigen Einstellungen aller Gerätefunktionen angezeigt. Die längste Anzeige besteht aus 225 Zeichen.

SOURCE

Art:

Einstellung oder Abfrage

Einstellsyntax:

SOURCE FRONT
SOURCE REAR
SOUR FRONT
SOUR REAR

Abfragesyntax:

SOURCE?
SOUR?

Abfrage-Antwort:

SOURCE FRONT;
SOURCE REAR;

Beschreibung:

SOURCE FRONT wählt für die Messung den Eingang auf der Frontplatte; SOURCE REAR wählt für die Messung die Interface-Anschlüsse an der Rückseite.



Um Beschädigungen des Gerätes und Betriebsfehler zu vermeiden, darf nicht zwischen dem Eingang auf der Frontplatte und den Interface-Anschlüssen auf der Rückseite umgeschaltet werden, wenn mehr als 500 V_S an den Eingangsanschlüssen auf der Frontplatte anliegen.

TEST

Art:

Ausgang

Syntax:

TEST

Antwort:

TEST 0;
TEST 351;

Beschreibung:

Zeigt eine Zahl an, welche den Status der Kalibrierungs-Prüfsumme angibt. 0 wenn die Prüfsumme richtig ist; 351 wenn sie falsch ist.

USER

Art:

Einstellung oder Abfrage

Einstellsyntax:

USER ON
USER OFF

Abfragesyntax:

USER?

Abfrage-Antwort:

USER ON;
USER OFF;

Beschreibung:

Mit diesem Befehl wird die Service-Abfrage der Taste INST ID freigegeben oder gesperrt. Ist sie freigegeben, gibt das Gerät SRQ aus, wenn auf der Frontplatte die Taste INST ID gedrückt wird.

MITTEILUNGEN UND KOMMUNIKATIONS-PROTOKOLL

Befehls-Trennzeichen

Eine Mitteilung besteht aus einem, oder einer Reihe von Befehlen und einem Endezeichen. Bei Mitteilungen, die aus mehreren Befehlen bestehen, müssen die Befehle durch Strichpunkte getrennt sein. Ein Strichpunkt am Ende einer Mitteilung ist zusätzlich. So ist z. B., jede der nachstehenden Zeilen eine Mitteilung.

```
INIT
TEST;INIT;RQS ON;USER OFF;ID?;SET?
TEST;
```

Mitteilungs-Endezeichen

Mitteilungen können mit EOI oder dem ASCII-Zeichen LF beendet sein. Einige Controller machen EOI mit dem letzten Daten-Byte geltend; andere verwenden nur LF als Endezeichen. Das Gerät kann intern so eingestellt werden, daß es beide Endezeichen annimmt. Wird EOI ONLY als Endezeichen gewählt, interpretiert das Gerät den Empfang eines Daten-Bytes mit EOI als Ende der Eingangsmittteilung; es macht dann auch EOI mit dem letzten Byte der Ausgangsmittteilung geltend. Bei der LF/EOI Einstellung, interpretiert das Gerät das LF-Zeichen ohne EOI (oder irgendein Datenbyte mit EOI) als Ende einer Eingangsmittteilung; es überträgt CR (carriage return) gefolgt von „line feed“ (LF mit EOI), um Ausgangsmittteilungen zu beenden. Servicepersonal findet Informationen über die Einstellung des Mitteilungs-Endezeichens im Abschnitt „Wartung“. Beim Versand sind TM 5000 Geräte auf EOI ONLY eingestellt.

Formatierung einer Mitteilung

Um verstanden zu werden, müssen Befehle, die an TM 5000 Geräte gesendet werden, das richtige Format (Syntax) haben; dieses Format ist jedoch flexibel und es werden viele Variationen angenommen. Nachstehend wird dieses Format und die annehmbaren Variationen beschrieben.

Die Geräte erwarten, daß alle Befehle in ASCII kodiert sind; sie nehmen jedoch große und kleine ASCII-Zeichen an. Die Datenausgabe erfolgt in großen Zeichen.

Wie vorher besprochen, besteht ein Befehl aus einem Kopfteil dem, falls erforderlich, Argumente folgen. Ein Befehl mit Argumenten muß ein Kopfteil-Endezeichen haben, das aus dem Zwischenraumzeichen SP zwischen Kopfteil und Argument besteht.

RQS_{SP}ON

Werden zusätzliche Formatierungszeichen SP, CR und LF (LF kann zur Formatierung nicht verwendet werden, wenn LF/EOI Endezeichen sind) zwischen Kopfteilendezeichen und Argument eingefügt, werden sie vom Gerät ignoriert.

Beispiel 1: RQS_{SP}ON;

Beispiel 2: RQS_{SP} SPON;

Beispiel 3: RQS_{SP} CR LF SP SPON

Im allgemeinen werden diese Formatierungszeichen nach jedem Endezeichen und am Anfang und Ende einer Mitteilung ignoriert.

SPRQS_{SP}ON;CR LF

SPUSER_{SP}OFF

In der Befehlsliste sind einige Kopfteile und Argumente in zwei Versionen aufgeführt, in der voll ausgeschriebenen Form und einer abgekürzten Form. Das Gerät nimmt alle Kopfteile und Argumente an, die zumindest die in der abgekürzten Form enthaltenen Zeichen besitzen; jedes weitere Zeichen muß dem in der voll ausgeschriebenen Form entsprechen. Zur Dokumentation von Programmen können der voll ausgeschriebenen Form Alphazeichen angehängt werden. Alphazeichen können auch einem Fragekopfteil angehängt werden, vorausgesetzt, am Ende steht ein Fragezeichen.

```
USER?
USERE?
USEREQ?
USEREQUEST?
```

Mehrfachargumente werden durch ein Komma getrennt; das Gerät nimmt jedoch auch einen Zwischenraum oder Zwischenräume als Trennzeichen an.

```
2,3
2SP3
2,SP3
```

ANMERKUNG

Im letzten Beispiel wird der Zwischenraum als Formatzeichen angesehen, da er hinter dem Komma steht (dem Argument-Trennzeichen).

Zahlen-Formate

Das Gerät akzeptiert die nachstehenden Zahlenarten für jedes numerische Argument.

Programmierung – DM 5010

- Ganze Zahlen mit und ohne Vorzeichen (einschl. + 0 und - 0). Ganze Zahlen ohne Vorzeichen werden als positiv angesehen. Beispiele: +1, 2, -1, -10.
- Dezimalzahlen mit und ohne Vorzeichen. Dezimalzahlen ohne Vorzeichen werden als positiv angesehen. Beispiele: -3.2, +5.0, 1.2.
- Gleitkommazahlen in wissenschaftlicher Schreibweise. Beispiele: +1.0E-2, 1.0E-2, 1.E-2, 0.01E+0.

Die höchste, als Argument akzeptierbare Zahl ist $\pm 3.4028E+38$.

Mitteilungs-Protokoll

Wenn das Gerät eine Mitteilung erhält, wird sie im Eingangs-Puffer gespeichert, bearbeitet und ausgeführt. Die Bearbeitung einer Mitteilung besteht aus der Dekodierung von Befehlen, dem Erkennen von Trennzeichen und dem Überprüfen der Syntax. Bei Einstellbefehlen speichert das Gerät die angezeigten Änderungen im Einstell-Puffer. Wird während der Bearbeitung ein Fehler entdeckt, gibt das Gerät eine Bedienungsabfrage (SRQ) aus, ignoriert den Rest der Mitteilung und stellt den Einstell-Puffer zurück. Durch Rückstellen des Einstell-Puffers werden unerwünschte Zustände vermieden, die dadurch entstehen können, daß einige Einstellbefehle der gleichen Mitteilung ausgeführt werden und andere nicht.

Die Ausführung einer Mitteilung besteht in der Durchführung der Tätigkeiten, die durch ihre Befehle spezifiziert sind. Bei Einstellbefehlen bedeutet das die Neueinstellung der Geräteeinstellungen und die Aufnahme dieser neuen Einstellungen in den Einstell-Puffer. Die Einstellbefehle werden in Gruppen ausgeführt – d.h., eine Reihe von Einstellbefehlen wird bearbeitet und in den Einstell-Puffer aufgenommen, bevor die Ausführung erfolgt. Das erlaubt dem Anwender einen neuen Status zu spezifizieren, ohne darauf zu achten, ob eine besondere Reihenfolge Gültigkeit hat. Die Durchführung der Einstellung erfolgt, wenn das Gerät das Mitteilungs-Endezeichen, einen Abfragebefehl oder einen Betriebsbefehl in einer Mitteilung bearbeitet.

Bearbeitet das Gerät einen Abfragebefehl in einer Mitteilung, dann werden zuerst alle vorhergehenden Einstellbefehle ausgeführt, um den Status des Gerätes auf den neuesten Stand zu bringen. Dann wird der Abfragebefehl ausgeführt, indem es die entsprechenden Daten abrufen und sie in den Ausgangspuffer gibt. Danach wird die Bearbeitung und Ausführung des Rests der Mitteilung fortgesetzt. Wenn das Gerät zum Sprecher (talker) gemacht wird, werden die Daten an den Controller weitergegeben.

Wenn das Gerät in einer Mitteilung einen Betriebsbefehl bearbeitet, werden vor dem Betriebsbefehl alle vorhergehenden Einstellbefehle ausgeführt.

Mehrfach-Mitteilungen

Der Eingangs-Puffer hat eine begrenzte Kapazität und eine einzelne Mitteilung kann so lang sein, daß er damit ausgefüllt ist. In diesem Falle wird ein Teil der Mitteilung bearbeitet bevor das Gerät weitere Daten annimmt. Während der Befehlsausführung hält das Gerät zusätzliche Daten zurück (durch NRD) bis im Puffer Platz zur Verfügung steht.

Wenn Platz vorhanden ist, kann das Gerät vor Ausführung der ersten eine zweite Mitteilung annehmen. Es hält jedoch zusätzliche Mitteilungen mit NRD zurück, bis die erste Mitteilung vollständig durchgeführt ist.

Nachdem das Gerät in einer Mitteilung einen Abfragebefehl ausgeführt hat hält es die Antwort zurück, bis es vom Controller zum Sprecher (talker) gemacht wird. Empfängt das Gerät eine neue Mitteilung bevor der gesamte Ausgang der vorherigen Mitteilung ausgelesen ist, macht es vor der Ausführung der neuen Mitteilung den Ausgangs-Puffer frei. Dadurch wird verhindert, daß der Controller unerwünschte Daten aus alten Mitteilungen erhält.

Eine weitere Situation kann das Gerät veranlassen den Ausgang zu löschen. Die Ausführung einer langen Mitteilung kann dazu führen, daß Eingangs- und Ausgangs-Puffer voll werden. Wenn dies geschieht, kann das Gerät die Ausführung der Mitteilung nicht beenden weil es darauf wartet, daß der Controller die erzeugten Daten ausliest; der Controller kann die Daten aber nicht auslesen, weil er mit der Übertragung seiner Mitteilung noch nicht zu Ende ist. Da der Eingangs-Puffer voll ist und das Gerät den Rest der Mitteilung des Controllers mit NRD zurückhält, hängt das System in der Schwebe weil Controller und Gerät aufeinander warten. Erkennt das Gerät diesen Zustand, erzeugt es eine Fehlermeldung, gibt ein SRQ aus und löscht die Daten im Ausgangs-Puffer. Das ermöglicht dem Controller den Rest der Mitteilung zu übertragen und der Controller wird informiert, daß die Mitteilung ausgeführt und der Ausgang gelöscht wurde.

Ein TM 5000 Gerät kann als Sprecher (talker) adressiert werden, ohne das es eine Mitteilung erhält, die angibt, was es ausgeben soll. In diesem Falle geben Erfassungsgeräte (Zähler und Multimeter) eine Messung aus wenn sie beendet ist. Ist keine Messung fertig, geben sie eine Byte-Mitteilung zurück bei der alle Bits gleich 1 sind (mit Endezeichen); andere TM 5000 Geräte geben nur diese Mitteilung zurück.

Gerätereaktionen auf IEEE 488 Interface Mitteilungen

Interface Mitteilungen und ihre Auswirkungen auf die Interface Funktionen des Gerätes sind im IEEE Standard 488-1978 definiert. Abkürzungen dieser Norm werden in dieser Diskussion verwendet, in der die Auswirkungen

der Interface Mitteilungen auf die Betriebsweise des Gerätes beschrieben werden.

UNL – Unlisten (63 mit ATN)
UNT – Untalk (95 mit ATN)

Wird der Befehl UNL empfangen, geht die Hörer (listener) Funktion des Gerätes in ihren Ruhezustand (nicht adressiert). Im Ruhezustand nimmt das Gerät keine Befehle vom GPIB an.

Die Sprecher (talker) Funktion geht in ihren Ruhezustand, wenn das Gerät den Befehl UNT empfängt. In diesem Zustand kann das Gerät über den GPIB keine Daten ausgeben. Wenn Talker und Listener Funktion im Ruhezustand sind, ist das Lämpchen „ADRESSED“ aus. Ist das Gerät entweder Talk- oder Listen adressiert, ist das Lämpchen an.

IFC – Interface Clear (GPIB Stift 9)

Diese einzeilige Mitteilung hat die gleiche Auswirkung wie die UNL und UNT Mitteilungen. Das Lämpchen ADRESSED auf der Frontplatte ist aus.

DCL – Device Clear (20 mit ATN)

Die Mitteilung Device Clear stellt die Kommunikation zwischen Controller und Gerät wieder her. Als Antwort auf DCL löscht das Gerät alle Eingangs- und Ausgangsmitteilungen und jede nicht ausgeführte Einstellung im Einstellungs-Puffer. Ebenso werden alle auf Abruf wartenden Fehler und Ereignisse gelöscht, mit Ausnahme des Einschalt-Ereignisses. Wenn aus irgendeinem anderen Grund als dem Einschaltvorgang ein SRQ ausgegeben ist, wird beim Empfang von DCL das SRQ gelöscht.

SDC – Selected Device Clear (4 mit ATN)

Diese Mitteilung erfüllt die gleiche Funktion wie DCL; jedoch nur Geräte die als Listener adressiert sind antworten auf SDC.

GET – Group Exekute Trigger (8 mit ATN)

Das Gerät spricht auf <GET> nur an, wenn es als Listener adressiert ist und die Geräte-Triggerfunktion durch den Befehl Device Trigger (DT) freigegeben worden ist. Wenn die DT Funktion gesperrt ist (DT OFF), das Gerät auf Frontplattenbedienung eingestellt ist oder beim Empfang von <GET> eine Mitteilung ausführt, wird die Mitteilung <GET> ignoriert und ein SRQ erzeugt.

SPE – Serial Poll Enable (24 mit ATN)
SPD – Serial Poll Disable (25 mit ATN)

Die Mitteilung SPE gibt das Gerät für die Ausgabe des Serial Poll Status Byte frei, wenn es als Talker adressiert ist. Durch die Mitteilung SPD wird das Gerät auf seinen

normalen Betrieb, die Sendung von Daten aus dem Ausgangs-Puffer, zurückgeschaltet.

MLA – My Listen Address
MTA – My Talk Address

Die primären Listen- und Talk Adressen werden durch die GPIB Adresse des Gerätes erstellt (intern eingestellt). Die jeweilige Einstellung der GPIB Adresse wird auf der Frontplatte dargestellt wenn der Knopf ID gedrückt wird. Wenn das Gerät Talk oder Listen adressiert ist, leuchtet das Lämpchen ADRESSED auf der Frontplatte.

LLO – Local Lockout (17 mit ATN)

LLO wird von dem Gerät mit einem Umschaltvorgang beantwortet – von LOCS auf LWLS oder von REMS auf RWLS.

REN – Remote Enable

Wenn REN aktiviert ist und das Gerät hat seine Listen Adresse empfangen, schaltet es auf einen Fernbedienungsstatus um (von LOCS auf REMS oder von LWLS auf RWLS). Ist REN nicht aktiv, also falsch, wird aus jedem Status eine Umschaltung auf LOCS veranlaßt; das Gerät bleibt solange in LOCS wie REN falsch ist.

Eine REN-Umschaltung kann nach dem Beginn einer Mitteilungsbearbeitung vorkommen. In diesem Falle wird die Ausführung der in Bearbeitung befindlichen Mitteilung durch eine Umschaltung nicht beeinflusst.

GTL – Go To Local (1 mit ATN)

Nur Listen-adressierte Geräte antworten auf GTL durch Umschalten auf Eigenbedienung. Umschaltungen von Fern- auf Eigenbedienung durch GTL beeinflussen nicht die Ausführung von Mitteilungen, die beim Empfang von GTL bearbeitet werden.

Remote-Local Operation

Die vorstehende Diskussion der Interface-Mitteilungen beschreibt die Statusumschaltungen durch GTL und REN. Die meisten Bedienungselemente auf der Frontplatte verursachen eine Umschaltung von REMS auf LOCS durch eine Mitteilung, die return-to-local (rtl) genannt wird. Diese Umschaltung kann während der Mitteilungsausführung vorkommen; aber im Gegensatz zu GTL- und REN-Umschaltungen wird durch eine Umschaltung, die durch rtl veranlasst wurde, die Mitteilungsausführung beeinflusst. In diesem Fall erzeugt das Gerät einen Fehler, wenn es irgendwelche nicht ausgeführte Einstell- oder Betriebsbefehle gibt. Bedienungselemente auf der Frontplatte, die nur die Darstellung ändern (wie INST ID) beeinflussen die Fern- Eigenbedienungs Zustände nicht – nur Bedienungselemente, die Einstellungen ändern, können rtl geltend machen.

Programmierung – DM 5010

Rtl wird ungültig nach Änderung der Einstellungen auf der Frontplatte. Da rtl Umschaltungen auf REMS verhindert, gibt das Gerät kein rtl aus, wenn eine Folge von Tasteneingaben nicht in angemessener Zeit beendet wird (etwa 5 bis 10 Sekunden).

Das Gerät behält eine Auflistung seiner Einstellungen im Einstell-Puffer, die durch neue Einstellungen auf der Frontplatte oder vom Controller aktualisiert werden. Ferner werden die Einstellungen auf der Frontplatte durch Befehle auf den neuesten Stand gebracht. Die Geräteeinstellungen werden durch Umschaltungen zwischen den vier remote-local Zuständen nicht beeinflusst. Bei REMS oder RWLS ist die Anzeige REMOTE erleuchtet.

Local State (LOCS)

In LOCS werden die Einstellungen des Gerätes durch die Bedienungsperson über die Bedienungselemente auf der Frontplatte gesteuert. In diesem Status werden nur Bus-Befehle ausgeführt, die die Einstellungen des Gerätes nicht verändern (Abfragebefehle); alle anderen Bus-Befehle (Einstellung und Betrieb) erzeugen einen Fehler, da ihre Funktionen über die Frontplatte gesteuert werden.

Local With Lockout State (LWLS)

Das Gerät arbeitet in gleicher Weise wie bei LOCS mit der Ausnahme, daß rtl keine Umschaltung auf Fernbedienung beinhaltet.

Remote State (REMS)

In diesem Status führt das Gerät alle Gerätebefehle aus. Bei Befehlen mit Anzeigen auf der Frontplatte, wird nach Ausführung dieser Befehle die Anzeige auf der Frontplatte aktualisiert.

Remote With Lockout State (RWLS)

Die Arbeitsweise des Gerätes entspricht der bei REMS mit der Ausnahme, daß die Mitteilung rtl ignoriert wird.

STATUS- UND FEHLERBERICHT

Über die Funktion Bedienungsabfrage (definiert in der IEEE-488 Norm) kann das Gerät den Controller darauf aufmerksam machen, daß es Bedienung benötigt. Dieser Bedienungsruf dient auch zur Anzeige, daß ein bestimmtes Ereignis (eine Stausänderung oder ein Fehler) aufgetreten ist. Um den Ruf zu bedienen, führt der Controller eine Serienabfrage durch; darauf antwortet das Gerät mit einem Statusbyte (STB) das anzeigt, ob es eine Bedienung verlangt hat oder nicht. Das STB kann auch eine begrenzte Menge an Information über den Bedienungsruf enthalten. Das Format der im STB kodierten Information wird in Bild 3-2 dargestellt.

Wenn das Datenbit 8 eingestellt ist, befördert das STB Statusinformation, die durch die Bits 1 bis 4 gekennzeichnet sind, Bit 4 wird eingestellt, wenn das DM 5010 auf eine Triggerung wartet; Bit 3 zeigt an, daß eine Messung zur Verfügung steht.

Da die vom STB beförderte Information über ein Ereignis begrenzt ist, sind die Ereignisse in Klassen aufgeteilt; die Klasse wird im Statusbyte angegeben. Die Ereignisklassen werden wie folgt definiert:

- COMMAND ERROR** Das Gerät hat einen Befehl empfangen, den es nicht verstehen kann.
- EXECUTION ERROR** Das Gerät hat einen Befehl empfangen, den es nicht ausführen kann, verursacht durch Argumente außerhalb des Bereichs oder widersprüchliche Einstellungen.
- INTERNAL ERROR** Das Gerät hat ein Hardware- oder Firmware-Problem entdeckt, das den Betrieb verhindert.
- SYSTEM EVENTS** Ereignisse, die für alle Geräte in einem System gleich sind (z. B. Power on, User Request usw.).
- INTERNAL WARNING** Dadurch wird angezeigt, daß das Gerät ein Problem entdeckt hat. Das Gerät bleibt in Betrieb, aber das Problem sollte berichtigt werden (z. B. die Kalibrierung stimmt nicht).
- DEVICE STATUS** Vom Gerät abhängige Ereignisse.



Bild 3-2. Definition der STB Bits

Das Gerät kann zusätzliche Informationen über viele der Ereignisse liefern, besonders über die im Statusbyte berichteten Fehler. Nach der Feststellung, daß das Gerät nach Service gerufen hat (durch Prüfung des STB), kann der Controller mit einer Fehleranfrage „ERR?“ weitere Informationen abfragen. Das Gerät antwortet mit einem Code, der das Ereignis definiert. Diese Codes werden in Tabelle 3-1 beschrieben.

**Tabelle 3-1
FEHLERABFRAGE UND STATUSINFORMATION**

| Beschreibung | Antwort auf Fehlerabfrage | Antwort auf Serial Poll ^a |
|--|---------------------------|--------------------------------------|
| Befehls-Fehler: | | |
| Ungültiges Befehls-Kopfteil | 101 | 97 |
| Fehler im Kopfteil-Trennzeichen | 102 | 97 |
| Fehler im Argument | 103 | 97 |
| Fehler im Argument-Trennzeichen | 104 | 97 |
| Argument fehlt | 106 | 97 |
| Ungültiges Mitteilungs-Endezeichen | 107 | 97 |
| Ausführungs-Fehler: | | |
| Bei Eigenbedienung nicht ausführbar | 201 | 98 |
| Einstellungen durch rtl verloren | 202 | 98 |
| Ein- und Ausgangs-Puffer voll | 203 | 98 |
| Argument außerhalb des Bereichs | 205 | 98 |
| Gruppentriggerung ignoriert | 206 | 98 |
| Nicht kalibriert | 231 | 98 |
| Außerhalb der Kalibrier- oder Null-Fähigkeit | 232 | 98 |
| Interne Fehler: | | |
| Unterbrechungs-Fehler | 301 | 99 |
| System-Fehler | 302 | 99 |
| Rechen-Fehler | 303 | 99 |
| Wandler-Ausfall | 311 | 99 |
| Frontplatten-Ausfall | 317 | 99 |
| Schlechte Ohm-Kalibrierkonstante | 318 | 99 |
| Kalibrier-Prüfsummenfehler | 351 | 99 |
| Normale Ereignisse | | |
| System-Ereignisse: | | |
| Einschaltvorgang | 401 | 65 |
| Arbeit beendet | 402 | 66 |
| ID Anwenderabfrage | 403 | 67 |
| Interne Warnung: | | |
| Bereichsüberschreitung | 601 | 102 |
| Gerätstatus^b: | | |
| Messung verfügbar | 0 | 132 |
| Warten auf Triggerung | 0 | 136 |
| Messung verfügbar und Warten auf Triggerung | 0 | 140 |
| Unterhalb der Grenzwerte | 701 | 193 |
| Oberhalb der Grenzwerte | 703 | 195 |
| Keine Fehler oder Ereignisse | 0 | 128 |

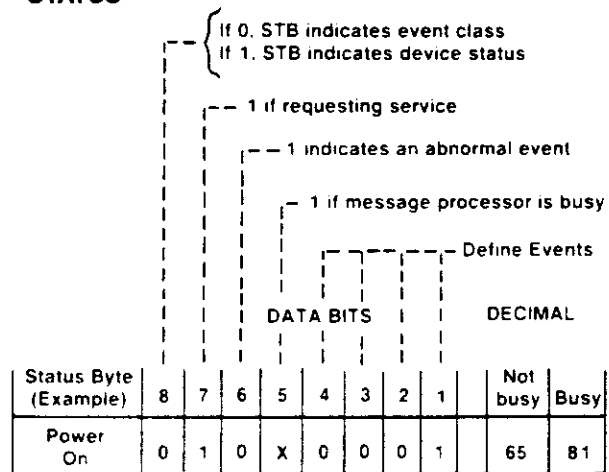
^aWenn das Gerät arbeitet, antwortetes mit einer Zahl, die um 16 höher ist als die angegebene Zahl.

^bBei Controllern der Serie 4050 wird der Befehl POLL für Serial Poll-Antworten zwischen 128 und 192 mit 0 beantwortet; man erhält die aufgelisteten Antworten durch die Statements WBYTE und RBYTE.

**Tabelle 3-2
FRONTPLATTEN UND FEHLERCODES**

| Darstellung | Beschreibung | |
|---------------------------|--|------|
| Ausführungs-Fehler | | |
| 205 | Argument außerhalb des Bereichs | |
| 231 | Nicht kalibriert | |
| 232 | Außerhalb der Kalibrierfähigkeit | |
| Interne Fehler | | |
| 303 | Rechen-Fehler | |
| 311 | Wandler-Ausfall | |
| 317 | Fronplatten-Ausfall | |
| 318 | Schlechte Ohm-Kalibrierkonstante | |
| 340 | RAM Fehler (positiv) | |
| 341 | RAM Fehler (negativ) | |
| 351 | Kalibrier-Prüfsummenfehler | |
| 372 | ROM Plazierungsfehler | C000 |
| 373 | ROM Plazierungsfehler | D000 |
| 374 | ROM Plazierungsfehler | E000 |
| 392 | ROM Prüfsummenfehler | C000 |
| 393 | ROM Prüfsummenfehler | D000 |
| 393 | ROM Prüfsummenfehler | E000 |
| 395 | ROM Prüfsummenfehler | F000 |
| 321 | Zeigt an, daß der GPIB Adressenschalter (Signatur-Analyse) freigegeben ist | |

Wenn mehr als ein Ereignis zu berichten ist, gibt das Gerät weiter SRQ aus bis alle Ereignisse berichtet sind. Nach dem Bericht über die Serienabfrage wird jedes Ereignis automatisch gelöscht. Die Interface-Mitteilung Device Clear (DCL) kann zur Löschung aller Ereignisse, mit Ausnahme von Power on, verwendet werden.

Zur Steuerung des Berichts einiger individueller Ereignisse und für das Sperren aller Bedienungsrufe stehen Befehle zur Verfügung. So bietet z. B. der Befehl User Request (USER) individuelle Steuerung über den Bericht der Anwenderabfrage, die nach Drücken der Taste INST ID auf der Frontplatte auftritt. Der Befehl Request for Service (RQS) steuert, ob das Gerät irgendein Ereignis mit SRQ berichtet.

RQS OFF hält alle SRQ's zurück (außer Power on), so daß die Abfrage ERR? in dieser Betriebsart dem Controller ermöglicht, Ereignisse herauszufinden, ohne zuerst eine Serienabfrage durchzuführen. Bei RQS OFF kann der Controller jederzeit die Abfrage ERR? stellen und das Gerät antwortet mit einem Ereignis, das darauf wartet berichtet zu werden. Der Controller kann durch Senden der Fehlerabfrage alle Ereignisse löschen, bis ein Nullcode (0) erscheint. oder alle Ereignisse, außer Power on, durch die Interface-Mitteilung DCL löschen.

Bei RQS OFF kann der Controller eine Serienabfrage durchführen, wobei das Statusbyte aber nur geräteabhängige Statusinformation enthält. Bei RQS ON enthält das STB die Klasse des Ereignisses und einen darauffolgenden im STB berichteten Fehler.

DAS SENDEN VON INTERFACE STEUER-MITTEILUNGEN

Die nachstehenden Controller-Befehle gelten für TEKTRONIX-Controller der Serie 4050 und repräsentativ für andere Controller.

Gerätebefehle werden an das DM 5010 in ASCII durch Anwendung der PRINT Statements übertragen. Als Antwort auf INPUT Statements vom Controller gibt das DM 5010 Daten aus. Zum Beispiel:

```
PRINT @ 16:„SET?“
INPUT @ 16:A$
```

wobei 16 die GPIB-Primäradresse des DM 5010 ist.

Interface-Steuermittelungen können mit den Controller-Befehlen WBYTE an das DM 5010 gesendet werden. In den folgenden Beispielen sind A und B die Talk- und Listenadressen des DM 5010. Für A die Primäradresse plus 32; für B die Primäradresse plus 64.

| | |
|-----------------------------|---------------|
| Listen (MLA) | WBYTE @ A: |
| Unlisten (UNL) | WBYTE @ 63: |
| Talk (MTA) | WBYTE @ B: |
| Untalk (UNT) | WBYTE @ 95: |
| Device Clear (DCL) | WBYTE @ 20: |
| Selected Device Clear (SDC) | WBYTE @ A,4: |
| Go To Local (GTL) | WBYTE @ A,1: |
| Remote With Lockout (RWLS) | WBYTE @ A,17: |
| Local With Lockout (LWLS) | WBYTE @ 17: |
| Group Execute Trigger <GET> | WBYTE @ A,8: |
| Serial Poll Enable (SPE) | WBYTE @ 24: |
| Serial Poll Disable (SPD) | WBYTE @ 25: |

Informationen über die Anwendung des RBYTE Statements enthält das Handbuch für Controller der Serie 4050.

EINSCHALT- (ANFANGS-) BEDINGUNGEN

Beim Einschalten führt der Microprozessor des DM 5010 eine Diagnoseroutine (Selbsttest) durch, um die Funktion des ROM und RAM zu prüfen. Wird kein Fehler entdeckt, schaltet das Gerät auf Eigenbedienung (LOCS) mit den in Tabelle 3-3 aufgelisteten Einstellungen um. Die SRQ Leitung am GPIB ist ebenfalls geltend gemacht.

Die in Tabelle 3-3 enthaltenen Einstellungen werden vom DM 5010 auch angenommen, wenn es den Befehl INIT ausführt. Die Bereichseinstellung für die Funktion DCV gilt nur für die erste Messung, da das Gerät im AUTO Bereich arbeitet.

Tabelle 3-3
DM 5010 EINSCHALT-EINSTELLUNGEN

| Kopfteil | Argument |
|----------|----------|
| AVE | 2 |
| CALC | OFF |
| DBR | 1 |
| DCV | -1.E+3 |
| DIGIT | 4.5 |
| DT | OFF |
| LFR | OFF |
| LIMITS | 0,0 |
| MODE | RUN |
| MONITOR | OFF |
| NULL | 0 |
| OPC | OFF |
| OVER | OFF |
| RATIO | 1,0 |
| RQS | ON |
| SOURCE | FRONT |
| USER | OFF |

ASCII & IEEE 488 (GPIB) CODE CHART

| BITS | | | | 0 0 | | 0 0 1 | | 0 1 0 | | 0 1 1 | | 1 0 0 | | 1 0 1 | | 1 1 0 | | 1 1 1 | | | | | | | | | | | | | | | | | | | | | |
|------|----|----|----|-----|----|-------|---------|-------|----|-------|-----------------|-------|-----|-------|------------|-------|-----|-------|-------|-----|---|---|--------------|----|------|----|------|----|------|----|------|----|------|----|------|----|-------|----|-------|
| B7 | B6 | B5 | B4 | B3 | B2 | B1 | CONTROL | | | | NUMBERS SYMBOLS | | | | UPPER CASE | | | | LOWER | | | | | | | | | | | | | | | | | | | | |
| 0 | 0 | 0 | 0 | 0 | 0 | 0 | 0 | 20 | 40 | 60 | 80 | 100 | 120 | 140 | 160 | NUL | DLE | SP | 0 | @ | P | ' | p | 0 | (0) | 10 | (16) | 20 | (32) | 30 | (48) | 40 | (64) | 50 | (80) | 60 | (96) | 70 | (112) |
| 0 | 0 | 0 | 1 | 1 | 1 | 1 | 1 | 21 | 41 | 61 | 81 | 101 | 121 | 141 | 161 | SOH | DC1 | ! | 1 | A | Q | a | q | 1 | (11) | 11 | (17) | 21 | (33) | 31 | (49) | 41 | (65) | 51 | (81) | 61 | (97) | 71 | (113) |
| 0 | 0 | 1 | 0 | 0 | 0 | 0 | 2 | 22 | 42 | 62 | 82 | 102 | 122 | 142 | 162 | STX | DC2 | " | 2 | B | R | b | r | 2 | (2) | 12 | (18) | 22 | (34) | 32 | (50) | 42 | (66) | 52 | (82) | 62 | (98) | 72 | (114) |
| 0 | 0 | 1 | 1 | 1 | 1 | 1 | 3 | 23 | 43 | 63 | 83 | 103 | 123 | 143 | 163 | ETX | DC3 | # | 3 | C | S | c | s | 3 | (3) | 13 | (19) | 23 | (35) | 33 | (51) | 43 | (67) | 53 | (83) | 63 | (99) | 73 | (115) |
| 0 | 1 | 0 | 0 | 0 | 0 | 0 | 4 | 24 | 44 | 64 | 84 | 104 | 124 | 144 | 164 | EOT | DC4 | \$ | 4 | D | T | d | t | 4 | (4) | 14 | (20) | 24 | (36) | 34 | (52) | 44 | (68) | 54 | (84) | 64 | (100) | 74 | (116) |
| 0 | 1 | 0 | 1 | 1 | 1 | 1 | 5 | 25 | 45 | 65 | 85 | 105 | 125 | 145 | 165 | ENQ | NAK | % | 5 | E | U | e | u | 5 | (5) | 15 | (21) | 25 | (37) | 35 | (53) | 45 | (69) | 55 | (85) | 65 | (101) | 75 | (117) |
| 0 | 1 | 1 | 0 | 0 | 0 | 0 | 6 | 26 | 46 | 66 | 86 | 106 | 126 | 146 | 166 | ACK | SYN | & | 6 | F | V | f | v | 6 | (6) | 16 | (22) | 26 | (38) | 36 | (54) | 46 | (70) | 56 | (86) | 66 | (102) | 76 | (118) |
| 0 | 1 | 1 | 1 | 1 | 1 | 1 | 7 | 27 | 47 | 67 | 87 | 107 | 127 | 147 | 167 | BEL | ETB | ' | 7 | G | W | g | w | 7 | (7) | 17 | (23) | 27 | (39) | 37 | (55) | 47 | (71) | 57 | (87) | 67 | (103) | 77 | (119) |
| 1 | 0 | 0 | 0 | 0 | 0 | 0 | 8 | 28 | 48 | 68 | 88 | 108 | 128 | 148 | 168 | BS | CAN | (| 8 | H | X | h | x | 8 | (8) | 18 | (24) | 28 | (40) | 38 | (56) | 48 | (72) | 58 | (88) | 68 | (104) | 78 | (120) |
| 1 | 0 | 0 | 1 | 1 | 1 | 1 | 9 | 29 | 49 | 69 | 89 | 109 | 129 | 149 | 169 | HT | EM |) | 9 | I | Y | i | y | 9 | (9) | 19 | (25) | 29 | (41) | 39 | (57) | 49 | (73) | 59 | (89) | 69 | (105) | 79 | (121) |
| 1 | 0 | 1 | 0 | 0 | 0 | 0 | 10 | 30 | 50 | 70 | 90 | 110 | 130 | 150 | 170 | LF | SUB | * | : | J | Z | j | z | 10 | (10) | 1A | (26) | 2A | (42) | 3A | (58) | 4A | (74) | 5A | (90) | 6A | (106) | 7A | (122) |
| 1 | 0 | 1 | 1 | 1 | 1 | 1 | 11 | 31 | 51 | 71 | 91 | 111 | 131 | 151 | 171 | VT | ESC | + | ; | K | [| k | { | 11 | (11) | 1B | (27) | 2B | (43) | 3B | (59) | 4B | (75) | 5B | (91) | 6B | (107) | 7B | (123) |
| 1 | 1 | 0 | 0 | 0 | 0 | 0 | 12 | 32 | 52 | 72 | 92 | 112 | 132 | 152 | 172 | FF | FS | , | < | L | \ | l | | 12 | (12) | 1C | (28) | 2C | (44) | 3C | (60) | 4C | (76) | 5C | (92) | 6C | (108) | 7C | (124) |
| 1 | 1 | 0 | 1 | 1 | 1 | 1 | 13 | 33 | 53 | 73 | 93 | 113 | 133 | 153 | 173 | CR | GS | - | = | M |] | m | } | 13 | (13) | 1D | (29) | 2D | (45) | 3D | (61) | 4D | (77) | 5D | (93) | 6D | (109) | 7D | (125) |
| 1 | 1 | 1 | 0 | 0 | 0 | 0 | 14 | 34 | 54 | 74 | 94 | 114 | 134 | 154 | 174 | SO | RS | . | > | N | ^ | n | ~ | 14 | (14) | 1E | (30) | 2E | (46) | 3E | (62) | 4E | (78) | 5E | (94) | 6E | (110) | 7E | (126) |
| 1 | 1 | 1 | 1 | 1 | 1 | 1 | 15 | 35 | 55 | 75 | 95 | 115 | 135 | 155 | 175 | SI | US | / | ? | UNL | o | o | RUBOUT (DEL) | 15 | (15) | 1F | (31) | 2F | (47) | 3F | (63) | 4F | (79) | 5F | (95) | 6F | (111) | 7F | (127) |

ADDRESSSED COMMANDS UNIVERSAL COMMANDS LISTEN ADDRESSES TALK ADDRESSES SECONDARY ADDRESSES OR COMMANDS

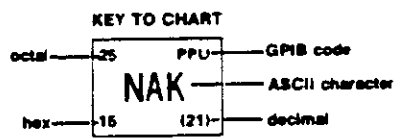

3391-13

Bild 3-3. ASCII und IEEE 488 (GPIB) Code.

Programmierung – DM 5010

Programm Beispiele

Sprecher/Hörer Programm für Controller der TEKTRONIX Serie 4050.

```
100 REM DM5010 Talker/Listener Program
110 REM DM5010 Primary Address = 16
120 INIT
130 ON SRQ THEN 260
140 DIM A$(200)
150 PRINT "Enter Message(s): ";
160 INPUT C$
170 PRINT @16:C$
180 REM Check for queries
190 IF POS(C$,"?",1)<>0 THEN 220
200 REM Check for 'SEND'
210 IF POS(C$,"SEND",1)=0 THEN 150
220 REM Input from device
230 INPUT @16:A$
240 PRINT A$
250 GO TO 150
260 REM Serial POLL Routine
270 POLL X,Y:16
280 PRINT "Status Byte: ";Y
290 RETURN
```

Diese Programm-Beispiele ermöglichen einem Anwender Gerätebefehle an das DM 5010 zu senden, um Geräteeinstellungen zu ändern und die erzeugten Daten abzurufen.

Weitere Unterstützung bei der Entwicklung spezieller, anwendungsorientierter Software finden Sie in den nachstehenden TEKTRONIX Handbüchern.

070-3985-GPIB Programming Guide. Dieses Handbuch wurde speziell für die Anwendung dieses Gerätes in IEEE-488 Systemen geschrieben. Es enthält Programmieranleitungen, Tips und einige spezielle Programmbeispiele.

070-2270-00-4051 GPIB Hardware Support Manual. Dieses Handbuch bietet eine eingehende Diskussion des IEEE-488 Bus Betriebs, Erklärungen der Bus Timing Details und frühe Bus Interface-Schaltungen.

Sprecher/Hörer Programm für Controller der TEKTRONIX Serie 4040.

```
90 REM DM5010 TALKER/LISTENER PROGRAM
95 REM DM5010 PRIMARY ADDRESS = 16
100 OPEN #1:"GPIB<PRI=16,EOM=<>>:"
110 ON SRQ THEN GOSUB 240
115 ENABLE SRQ
120 DIM A$ TO (200)
130 PRINT "ENTER COMMAND(S) / QUERY "
140 INPUT C$
145 IF C$="EX" THEN GOTO 230
150 PRINT #1:C$
160 REM CHECK FOR QUERIES
170 IF POS(C$,"?",1)<>0 THEN GOTO 200
180 IF POS(C$,"SEND",1)=0 THEN GOTO 130
190 REM INPUT FROM DEVICE
200 INPUT #1:A$
210 PRINT A$
220 GOTO 130
230 STOP
240 POLL SB,P,S:16
250 PRINT "SRQ SEEN, STATUS BYTE WAS:".SB
260 RETURN
```

070-2058-01 – Programmieren in BASIC.

070-2059-01 – Graphisches Programmieren in BASIC.

062-5971-01 – Programmierungshilfen Serie 4050, T1 (incl. Software).

062-5972-01 – Programmierungshilfen Serie 4050, T2 (incl. Software).

070-2380-01 – 4907 File Manager Betriebsanleitung.

070-2128-00 – 4924 Anwender-Handbuch.

070-1940-01 – Graphisches System Serie 4050 Betriebsanleitung.

070-2056-01 – Graphisches System Serie 4050 Bezugshandbuch.

070-3918-00 – 4041 Betriebsanleitung.

061-2546-00 – 4041 Programmierungs-Handbuch.

PROGRAMMIERUNGSHILFEN

Diese Besprechung der Programmierungsvorschläge und die Programmbeispiele dienen als Hilfe bei der Entwicklung von Programmen zur Steuerung des DM 5010. Die Programmbeispiele wurden mit einem Controller der Serie 4050 und dem DM 5010 entwickelt; bei einigen Beispielen wurden auch andere TM 5000 Geräte verwendet.

Ein erster Programmierungsvorschlag betrifft die Einstellung der Betriebsartenschalter des DM 5010 für das Mitteilungs-Endezeichen, die GPIB Adresse und die Betriebsart Talk Only. Zur Bestimmung ihrer derzeitigen Einstellung drücken Sie die Taste INST ID. Die dargestellte Zahl ist die gewählte GPIB Primäradresse; das Dezimalzeichen ganz rechts leuchtet auf, wenn als Mitteilungs-Endezeichen LF/EOI gewählt ist; das Minuszeichen leuchtet auf, wenn die Betriebsart Talk Only gewählt ist. Hinweise zur Änderung der Schaltereinstellungen findet qualifiziertes Servicepersonal in diesem Handbuch im Abschnitt „Wartung“.

In den Programmbeispielen ist die Variable D der GPIB Primäradresse des DM 5010 zugeordnet von der angenommen wird, daß sie auf das Dezimaläquivalent 16 eingestellt ist. Die Verwendung einer Variablen eliminiert die Wiederholung der Adressen-Dezimalzahl und ermöglicht die einfache Änderung der Adresse im Programm.

Behandlung von Service-Abfragen (SRQ)

Beim Einschalten macht das DM 5010 SRQ geltend. Das Einschalt SRQ ist eingesetzt, um den Controller zu informieren, wenn die Spannungsquelle während der Programmbearbeitung unterbrochen wird, da dies die richtige Programmausführung beeinflussen kann. Wenn RQS freigegeben ist, kann das DM 5010 auch für andere Ereignisse SRQ geltend machen (siehe Tabelle 3-1, Fehlerabfrage und Status-Information). Einige Controller können SRQ's ignorieren; andere Controller müssen alle SRQ's bedienen. Wenn SRQ's im Programm bedient werden müssen, stellen Sie sicher, daß seine Unterbrechung freigegeben wird.

Interrupt Handler

Eine Interrupt gesteuerte Routine zur Bedienung von SRQ's, die während der Programmbearbeitung auftreten. Ein Interrupt-Handler besteht im wesentlichen aus einem ON SRQ Statement am Anfang des Programms und einer Serial Poll-Routine irgendwo im Programm. Das ON SRQ Statement richtet die Programmsteuerung auf die Serienabfrage-Routine wenn ein SRQ auftritt. Siehe Programmbeispiel 1 oder 3, Zeile 110 für ON SRQ Statements. Wenn ein SRQ Interrupt auftritt, führt der

Controller die Serienabfrage-Routine durch. In einem POLL Statement gibt die erste Variable die Geräteposition in der Liste der GPIB Adressen an; die zweite Variable gibt das Statusbyte an. Eine Serienabfrage eines Gerätes am Bus wird in Beispiel 3, Zeile 1000 illustriert. In Beispiel 4 fragt Zeile 400 drei Geräte auf dem Bus ab und verwendet die Variable für jede Geräteadresse. In jedem Beispiel zeigt POLL das Statusbyte des Gerätes an, das SRQ geltend gemacht hat. Programmbeispiel 9 Zeilen 150, 160 und 170 faßt eine Serienabfrage mit den Statements WBYTE und RBYTE der Serie 4050 zusammen.

Die Serienabfrage-Routine kann zur Dekodierung von Information über das SRQ auslösende Ereignis erweitert werden. Die Zeilen 510 und 520 in Beispiel 1 löschen das Arbeitsbit im Statusbyte; die Zeilen 530 bis 560 dekodieren das Statusbyte und die Zeilen 1000 bis 7030 drucken die Ereignisklasse aus.

Programmbeispiel 7 verwendet das MONITOR SRQ um Messungen herauszufinden, die oberhalb oder unterhalb der mit dem Befehl LIMITS eingestellten Grenzwerte liegen. Die Zeilen 1020, 1040, und 1045 dekodieren das Statusbyte und veranlassen den entsprechenden Ausdruck auf dem Controllerdisplay.

In Programmbeispiel 2, Zeile 130 fragt der Controller das Gerät an Adresse 16 ab, um das Einschalt-SRQ zu löschen. Zeile 116 schaltet RQS ab, um weitere SRQ's zu verhindern. Wenn RQS OFF ist, kann die Abfrage ERR? in das Programm eingefügt werden, um wenn es erforderlich ist, einen Ereignisstatus zu bestimmen.

Frontplatten-Abschaltung

Die Bedienung von der Frontplatte kann abgeschaltet werden, so daß nur der Controller Geräteeinstellungen ändern kann. Zur Abschaltung der Frontplatte machen Sie zuerst REN geltend. Solange Abschaltung der Frontplatte gewünscht wird, muß REN gültig bleiben. Bei Controllern der Serie 4050 macht das RUN Statement automatisch REN geltend; das Statement END hebt REN auf. Dann senden Sie die Interface-Mitteilung LLO (Dezimaläquivalent 17 mit ATN). Bei der Serie 4050 geschieht dies mit dem Statement WBYTE. Zuletzt adressieren Sie das Gerät, indem Sie einen Einstell- oder Abfragebefehl mit dem Statement PRINT @ D: oder nur die Listen-Adresse mit einem WBYTE Statement senden. Nach diesen drei Schritten ist die Frontplatte abgeschaltet und bleibt so, bis REN falsch wird oder eine <GTL> Mitteilung (Dezimaläquivalent 1 mit ATN) gesendet wird. Siehe Programmbeispiel 4, Zeilen 150 und 190; und Beispiel 5, Zeilen 130 und 220.

Die Verwendung von INIT

Die Verwendung des Befehls INIT vereinfacht das Programm, da man gewöhnlich weniger Befehle zur Einstellung des Gerätestatus benötigt als für die individuelle Spezifizierung aller Einstellungen. Im Programmbeispiel 6, Zeile 150 empfängt das DM 5010 den Befehl INIT gefolgt von einer Serie von Befehlen, die den Gerätestatus von den INIT (Einschalt-) Einstellungen in den gewünschten Status ändern.

Löschen einer Darstellung

Nach einer Änderung des Eingangs kann es wünschenswert sein, die derzeitige Anzeige zu löschen, da sie nicht mehr der jetzigen Meßbedingung entspricht. Eine Möglichkeit ist es, dem Gerät einen Einstellbefehl zu senden – dies veranlaßt das Gerät die Daten im Ausgangs-Puffer zu löschen. Ein weiterer Weg ist dem Controller eine Messung einzugeben und sie zu ignorieren.

Durch Verwendung von MODE TRIG bei der Messung können ungültige Anzeigen vermieden werden.

Allowing Settling Time

Um sicherzustellen, daß die an den Controller übermittelte Messung gültig ist, kann in einem Programm Settling Time enthalten sein. Siehe Step Response Time im Abschnitt „Spezifikation“.

In Programmbeispiel 4 verwenden die Zeilen 230–250 eine FOR...NEXT Schleife zur Eingabe von fünf Messungen in die Variable R. Am Ende der Schleife enthält die Variable R die fünfte Messung.

In Programmbeispiel 5 Zeilen 290–320 werden zwei DM 5010 Messungen verglichen; wenn die Differenz größer als 0,001 ist, wird eine weitere Messung zum Vergleich herangezogen. Die Vergleiche werden wiederholt bis die Differenz anzeigt, daß zwei Messungen nahezu gleich sind.

Getriggerte Messungen

Zur Auflösung einer einzelnen Umwandlung verwenden Sie MODE TRIG und initiieren eine Triggerroutine mit einem der nachstehenden Vorgänge:

1. Adressieren Sie das Gerät als Talker. Siehe Programmbeispiel 2, Zeile 180.

2. Befehl SEND.

3. Senden Sie DTTRIG. Dann triggern Sie das DM 5010 durch Übertragung einer Group Execute Trigger (GET) Interface Mitteilung (Dezimaläquivalent 8 mit ATN). Siehe Programmbeispiel 9, Zeilen 120 und 5.

4. Wenn die Betriebsart EXTRIG freigegeben ist, halten Sie für 10 µs oder weniger P1031-16A am Isolation Board auf Masse.

5. Veranlassen Sie, daß die Bedienungsperson die Taste TRIGGERED auf der Frontplatte drückt.

Für wiederholte (freilaufende) Triggerroutine verwenden Sie den Befehl MODE RUN. Ist die Betriebsart EXTRIG freigegeben, halten Sie P1031-16A am Isolation Board auf Masse.

Verfügbarkeit von Ablesungen

Wenn das Gerät als Talker adressiert ist oder wenn der Befehl SEND zum Abrufen von Daten verwendet wird, ist es nicht erforderlich zu bestimmen, ob eine Ablesung verfügbar ist. Für jede dieser Abrufmethoden triggert das Gerät eine Übertragung wenn keine Ablesung ansteht.

Für andere Abrufmethoden gibt es mehrere Wege zu bestimmen, ob eine Ablesung verfügbar ist.

1. Senden Sie den Abrufbefehl RDY?. Ist die Antwort 1 ist eine Ablesung fertig. Siehe Programmbeispiel 3, Zeile 140.

2. Stellen Sie OPC ON und RQS ON. Das Gerät macht SRQ geltend, wenn eine Ablesung verfügbar ist. Siehe Beispiel 8, Zeile 150.

3. Wiederholen Sie eine Serienabfrage-Routine mit den Statements WBYTE bis das Statusbyte 132, 148, 140 oder 156 ist. Siehe Beispiel 9, Zeilen 150 und 200.

RDY?, OPC ON und die Serienabfrage-Routine sind nützlich, wenn mehrere Aufgaben gleichzeitig ablaufen.

Senden an einen Hörer (Listener)

Um eine DM 5010 Messung an einen GPIB Listener übertragen zu können, muß das empfangende Gerät als Listener adressiert sein. Dann adressieren Sie das DM 5010 als Talker für die Übertragung der Messungen. Erfolgt die Sendung an einen Controller, können die Daten in einen String oder numerische Variable gelesen werden. Siehe Programmbeispiele 2, Zeile 180 und 3, Zeile 150.

WARNING

THE FOLLOWING SERVICING INSTRUCTIONS ARE FOR USE BY QUALIFIED PERSONNEL ONLY. TO AVOID PERSONAL INJURY, DO NOT PERFORM ANY SERVICING OTHER THAN THAT CONTAINED IN OPERATING INSTRUCTIONS UNLESS YOU ARE QUALIFIED TO DO SO. REFER TO OPERATORS SAFETY SUMMARY AND SERVICE SAFETY SUMMARY PRIOR TO PERFORMING ANY SERVICE.



PERFORMANCE CHECK

Introduction

This performance check verifies the Electrical Performance Requirements as listed in the Specification section in this manual. Perform the Adjustment Procedure if the instrument fails to meet these checks. For convenience, many steps in this procedure check the performance of this instrument at only one value in the specified performance range. Any value within the specified range, within appropriate limits, may be substituted. The performance check may be done at any ambient temperature between 0° and +50°C. Performance limits for two ambient temperature ranges are listed for some steps. Use the data listed for the tempera-

ture at which the instrument is operating. A summary sheet is provided at the back of this section for recording performance check results.

Test Equipment Required

The test equipment listed in Table 5-1, or equivalent, is recommended to perform the performance check. Specifications given for the test equipment are the minimum necessary for accurate performance verification. All test equipment is assumed to be correctly calibrated and operating within specification.

Table 5-1
TEST EQUIPMENT LIST

| Description | Minimum Requirements | Performance Check Step | Recommended Equipment |
|-----------------------------|---|------------------------|--|
| TM 5000-Series Power Module | | all | TEKTRONIX TM 5003, Opt. 02 |
| Dc voltage calibrator | ± 200 mV: $\pm(0.0038\%$ of rdng + 0.0025% of range) ± 2 V-200 V: $\pm(0.0038\%$ of rdng + 0.0013% of range) ± 1000 V: $\pm(0.005\%$ of rdng + 0.0025% of range) | 1, 2, 3 | Fluke 335D Dc Voltage Standard |
| Ac voltage calibrator | 200 mV through 200 V: 10-20 Hz: $\pm(0.20\%$ of rdng + 0.08% of range) 20-100 Hz: $\pm(0.20\%$ of rdng + 0.05% of range) 100 Hz-20 kHz: $\pm(0.05\%$ of rdng + 0.05% of range) 20-100 kHz: $\pm(0.25\%$ of rdng + 0.12% of range) 700 V: 10-20 Hz: $\pm(0.20\%$ of rdng + 0.22% of range) 20-100 Hz: $\pm(0.20\%$ of rdng + 0.15% of range) 100 Hz-15 kHz: $\pm(0.05\%$ of rdng + 0.15% of range) | 2, 3, 4 | Fluke 5200A Ac Calibrator, and Fluke 5215A Power Amplifier |

Table 5-1 (cont)

| Description | Minimum Requirements | Performance Check Step | Recommended Equipment |
|----------------------------------|--|------------------------|---|
| Resistance standard ^a | 200 Ω: ±(0.0038% of rdng + 0.0038% of range) 2 k-200 kΩ: ±(0.0038% of rdng + 0.0025% of range) 2 MΩ: ±(0.025% of rdng + 0.0025% of range) 20 MΩ: ±(0.038% of rdng + 0.0012% of range) | 5 | Electro Scientific Industries, Inc. DB 62 Dekabox and SR1 10 MΩ Standard Resistor |
| Counter | 100 MHz ± 0.0016% | 4 | TEKTRONIX DC 509 Universal Counter/Timer ^b |
| Resistor | 100 kΩ, ± 5%, 1/4 W | 3 | Tektronix Part No. 315-0104-00 |
| Resistor | 604 Ω, ± 1%, 1/4 W | 6 | Tektronix Part No. 322-0172-00 |
| Controller | GPIB compatible | 9 | TEKTRONIX 4050-Series Controller or TEKTRONIX 4041 Controller |

^aResistance of Dekabox and interconnect cable must be known to the accuracy listed in Table 5-1 for each point checked in the Ohms Accuracy check.

^bRequires a TM 500/5000-Series power module.

Preparation

Make certain the 50-60 Hz jumper is positioned to match the power module line frequency. To check the jumper position, turn the two plastic fasteners on the left side cover and remove the cover. Refer to Fig. 10-1 in the pullout pages for the jumper location and position. Replace the side cover.

Install the DM 5010 in the power module, and apply power. Allow 30 minutes warm-up time (60 minutes after storage in high-humidity environment) before beginning the performance check.



Dangerous voltages may be encountered in the following steps. Caution must be exercised. Do not contact the output connectors of the voltage calibrator, the input terminals of the DM 5010, or the internal circuitry of the DM 5010. Set all voltage calibrators to a minimum output before making the necessary connections.

Preliminary Control Settings

| | |
|-------------------|---------------------|
| DCV | on |
| NULL | off |
| LOW FREQ RESPONSE | off |
| RANGE | STEP (200 mV range) |
| TRIGGER MODE | RUN on |
| CONVERSION RATE | FAST off |
| CALCULATIONS | all off |
| REAR INPUT | off |

1. Check Dc Voltage Accuracy

a. Set the DM 5010 front-panel controls to match the preliminary control settings listed above.

b. Connect the dc voltage calibrator to the DM 5010 HIGH and LOW input connectors through appropriate cables and adapters.

c. Set the calibrator output to the voltage listed in Table 5-2.

d. CHECK—that the DM 5010 display reads within the display limits listed in the table.

g. Repeat parts c through f for the succeeding lines of the table.

e. Set the CONVERSION RATE (FAST button) as listed in the next line of the table.

h. Set the calibrator to a minimum output voltage.

f. CHECK—that the DM 5010 display reads within the limits listed in the table.

i. Remove all connections to the DM 5010.

Table 5-2
DC VOLTAGE ACCURACY

| DM 5010 Range | Dc Calibrator Voltage | DM 5010 FAST | Display Limits | |
|---|-----------------------|--------------|--|--|
| | | | Ambient Temp. Range +18 to +28°C | Ambient Temp. Range 0 to +18°C, +28 to +50°C |
| 200 mV | 0.0 V | off on | +0.02 to -0.02 +0.1 to -0.1 | +0.07 to -0.07 +0.2 to -0.2 |
| 2 V | 0.0 V | on off | +.001 to -.001 +.0001 to -.0001 | +.002 to -.002 +.0006 to -.0006 |
| 20 V | 0.0 V | off on | +0.001 to -0.001 +0.01 to -0.01 | +0.006 to -0.006 +0.02 to -0.02 |
| 200 V | 0.0 V | on off | +0.1 to -0.1 +0.01 to -0.01 | +0.2 to -0.2 +0.06 to -0.06 |
| 1000 V | 0.0 V | off on | +0.1 to -0.1 +1. to -1. | +0.4 to -0.4 +2. to -2. |
| 200 mV | 190 mV | off on | 189.95 to 190.05 189.8 to 190.2 | 189.82 to 190.18 189.6 to 190.4 |
| 2 V | 1.9 V | on off | 1.898 to 1.902 1.8996 to 1.9004 | 1.896 to 1.904 1.8983 to 1.9017 |
| 20 V | 19. V | off on | 18.996 to 19.004 18.98 to 19.02 | 18.983 to 19.017 18.96 to 19.04 |
| 200 V | 190. V | on off | 189.8 to 190.2 189.96 to 190.04 | 189.6 to 190.4 189.83 to 190.17 |
| 1000 V | 950. V | off on | 949.7 to 950.3 948. to 952. | 949.0 to 951.0 947. to 953. |
| Set the calibrator output to a minimum level. | | | | |
| 200 mV | -190 mV | off on | -189.95 to -190.05 -189.8 to -190.2 | -189.82 to -190.18 -189.6 to -190.4 |
| 2 V | -1.9 V | on off | -1.898 to -1.902 -1.8996 to -1.9004 | -1.896 to -1.904 -1.8983 to -1.9017 |
| 20 V | -19. V | off on | -18.996 to -19.004 -18.98 to -19.02 | -18.983 to -19.017 -18.96 to -19.04 |
| 200 V | -190. V | on off | -189.8 to -190.2 -189.96 to -190.04 | -189.6 to -190.4 -189.83 to -190.17 |
| 1000 V | -950. V | off on | -949.7 to -950.3 -948. to -952. | -949.0 to -951.0 -947. to -953. |

Performance Check—DM 5010

2. Check Ac Voltage Accuracy

a. Set the DM 5010 front-panel controls to the preliminary control settings with the following exception:

ACV+DCV on

b. Connect the ac sinewave voltage calibrator to the DM 5010 HIGH and LOW input connectors.

c. Set the ac voltage calibrator output to the voltage and frequency listed in Table 5-3 or 5-4, depending on the ambient temperature.

NOTE

For the 10 and 20 Hz checks, press the LOW FREQ RESPONSE button to obtain a stable display. Release the button for the remaining frequency checks.

d. CHECK—that the DM 5010 display reads within the display limits for the frequencies and FUNCTIONS listed in the table (Dc input limits using ACV+DCV function are checked later in this step.)

e. Set the CONVERSION RATE (FAST button) as listed in the next line of the table.

f. CHECK—that the DM 5010 display reads within the limits for the frequencies and FUNCTIONS listed in the table.

g. Repeat parts c through f for each remaining line of the table. For the 200 and 700 V range checks, use the power amplifier.

h. Set the ac voltage calibrator to a minimum output and replace the ac calibrator with the dc voltage calibrator.

i. Set the DM 5010 range and the FAST button as listed in the first line of the table.

j. Set the dc calibrator output to the first voltage listed in the table.

k. Repeat parts d through f for each line of the table, checking only the display limits for dc input.

l. Set the dc voltage calibrator to a minimum output and remove all connections to the DM 5010.

**Table 5-3
AC VOLTAGE ACCURACY**

(Ambient Temp. Range +18 to +28°C)

| DM 5010 Range | Calibrator Voltage | DM 5010 FAST | DM 5010 FUNCTION | | | | |
|---------------|--------------------|--------------|----------------------|--------------------|------------------|------------------|------------------|
| | | | ACV+DCV | ACV | ACV | ACV+DCV | ACV |
| | | | Calibrator Frequency | | | | |
| | | | 10 Hz ^a | 20 Hz ^a | 20 kHz | Dc | 100 kHz |
| | | | Display Limits | | | | |
| 200 mV | 190. mV | off | 192.12 to 187.88 | 191.92 to 188.08 | 190.78 to 189.22 | 191.48 to 188.52 | 192.90 to 187.10 |
| | 100. mV | | 101.40 to 98.60 | 101.20 to 98.80 | 100.60 to 99.40 | 101.30 to 98.70 | 102.00 to 98.00 |
| | 10. mV | | 10.68 to 9.32 | 10.46 to 9.54 | 10.42 to 9.58 | 11.12 to 8.88 | 11.10 to 8.90 |
| 200 mV | 190. mV | on | 192.1 to 187.9 | 191.9 to 188.1 | 190.8 to 189.2 | 191.5 to 188.5 | 192.9 to 187.1 |
| | 100. mV | | 101.4 to 98.6 | 101.2 to 98.8 | 100.6 to 99.4 | 101.3 to 98.7 | 102.0 to 98.0 |
| | 10. mV | | 10.7 to 9.3 | 10.5 to 9.5 | 10.5 to 9.5 | 11.2 to 8.8 | 11.1 to 8.9 |

Table 5-3 (cont)

| DM 5010 Range | Calibrator Voltage | DM 5010 FAST | DM 5010 FUNCTION | | | | |
|------------------|----------------------------|-----------------|----------------------|--------------------|------------------|------------------|------------------|
| | | | ACV+DCV | ACV | ACV | ACV+DCV | ACV |
| | | | Calibrator Frequency | | | | |
| | | | 10 Hz ^a | 20 Hz ^a | 20 kHz | Dc | 100 kHz |
| | | | Display Limits | | | | |
| 2 V | 1.9 V 1. V .1 V | on | 1.921 to 1.879 | 1.919 to 1.881 | 1.908 to 1.892 | | 1.929 to 1.871 |
| | | | 1.014 to .986 | 1.012 to .988 | 1.006 to .994 | | 1.020 to .980 |
| | | | .107 to .093 | .105 to .095 | .105 to .095 | | .111 to .089 |
| | 1.9 V 1. V .1 V | off | 1.9212 to 1.8788 | 1.9192 to 1.8808 | 1.9078 to 1.8922 | | 1.9290 to 1.8710 |
| | | | 1.0140 to .9860 | 1.0120 to .9880 | 1.0060 to .9940 | | 1.0200 to .9800 |
| | | | .1068 to .0932 | .1046 to .0954 | .1042 to .0958 | | .1110 to .0890 |
| 20 V | 19. V 10. V 1. V | off | 19.212 to 18.788 | 19.192 to 18.808 | 19.078 to 18.922 | | 19.290 to 18.710 |
| | | | 10.140 to 9.860 | 10.120 to 9.880 | 10.060 to 9.940 | | 10.200 to 9.800 |
| | | | 1.068 to .932 | 1.046 to .954 | 1.042 to .958 | | 1.110 to .890 |
| | 19. V 10. V 1. V | on | 19.21 to 18.79 | 19.19 to 18.81 | 19.08 to 18.92 | | 19.29 to 18.71 |
| | | | 10.14 to 9.86 | 10.12 to 9.88 | 10.06 to 9.94 | | 10.20 to 9.80 |
| | | | 1.07 to .93 | 1.05 to .95 | 1.042 to .958 | | 1.11 to .89 |
| 200 V | 190. V 100. V 10. V | on | 192.1 to 187.9 | 191.9 to 188.1 | 190.8 to 189.2 | 191.4 to 188.6 | 192.9 to 187.1 |
| | | | 101.4 to 98.6 | 101.2 to 98.8 | 100.6 to 99.4 | 101.2 to 98.8 | 102.0 to 98.0 |
| | | | 10.7 to 9.3 | 10.5 to 9.5 | 10.5 to 9.5 | 11.1 to 8.9 | 11.1 to 8.9 |
| | 190. V 100. V 10. V | off | 192.12 to 187.88 | 191.92 to 188.08 | 190.78 to 189.22 | 191.38 to 188.62 | 192.90 to 187.10 |
| | | | 101.40 to 98.60 | 101.20 to 98.80 | 100.60 to 99.40 | 101.20 to 98.8 | 102.00 to 98.00 |
| | | | 10.68 to 9.32 | 10.46 to 9.54 | 10.42 to 9.58 | 11.02 to 9.98 | 11.10 to 8.90 |
| | | | | 15 kHz | Dc | | |
| 700 V | 665. V 350. V 100. V | off | 676.6 to 653.4 | 674.5 to 655.5 | 670.5 to 659.5 | 669.5 to 660.5 | |
| | | | 359.1 to 340.9 | 357.0 to 343.0 | 354.9 to 345.1 | 354.2 to 345.8 | |
| | | | 107.1 to 92.9 | 105.0 to 95.0 | 104.4 to 95.6 | 103.7 to 96.3 | |
| | 665. V 350. V 100 V | on | 677. to 653. | 675. to 655. | 671. to 659. | 670. to 650. | |
| | | | 359. to 341. | 357. to 343. | 355. to 345. | 355. to 345. | |
| | | | 107. to 93. | 105. to 95. | 105. to 95. | 104. to 96. | |

^aUse LOW FREQ RESPONSE.

Table 5-4
AC VOLTAGE ACCURACY

(Ambient Temp. Range 0 to +18°C, +28 to +50°C)

| DM 5010 Range | Calibrator Voltage | DM 5010 FAST | DM 5010 FUNCTION | | | | |
|---------------|----------------------------|--------------|----------------------|--------------------|------------------|------------------|------------------|
| | | | ACV+DCV | ACV | ACV | ACV+DCV | ACV |
| | | | Calibrator Frequency | | | | |
| | | | 10 Hz ^a | 20 Hz ^a | 20 kHz | Dc | 100 kHz |
| | | | Display Limits | | | | |
| 2 V | 1.9 V 1. V .1 V | on | 1.921 to 1.879 | 1.919 to 1.881 | 1.908 to 1.892 | | 1.929 to 1.871 |
| | | | 1.014 to .986 | 1.012 to .988 | 1.006 to .994 | | 1.020 to .980 |
| | | | .107 to .093 | .105 to .095 | .105 to .095 | | .111 to .089 |
| | 1.9 V 1. V .1 V | off | 1.9212 to 1.8788 | 1.9192 to 1.8808 | 1.9078 to 1.8922 | | 1.9290 to 1.8710 |
| | | | 1.0140 to .9860 | 1.0120 to .9880 | 1.0060 to .9940 | | 1.0200 to .9800 |
| | | | .1068 to .0932 | .1046 to .0954 | .1042 to .0958 | | .1110 to .0890 |
| 20 V | 19. V 10. V 1. V | off | 19.212 to 18.788 | 19.192 to 18.808 | 19.078 to 18.922 | | 19.290 to 18.710 |
| | | | 10.140 to 9.860 | 10.120 to 9.880 | 10.060 to 9.940 | | 10.200 to 9.800 |
| | | | 1.068 to .932 | 1.046 to .954 | 1.042 to .958 | | 1.110 to .890 |
| | 19. V 10. V 1. V | on | 19.21 to 18.79 | 19.19 to 18.81 | 19.08 to 18.92 | | 19.29 to 18.71 |
| | | | 10.14 to 9.86 | 10.12 to 9.88 | 10.06 to 9.94 | | 10.20 to 9.80 |
| | | | 1.07 to .93 | 1.05 to .95 | 1.042 to .958 | | 1.11 to .89 |
| 200 V | 190. V 100. V 10. V | on | 192.1 to 187.9 | 191.9 to 188.1 | 190.8 to 189.2 | 191.4 to 188.6 | 192.9 to 187.1 |
| | | | 101.4 to 98.6 | 101.2 to 98.8 | 100.6 to 99.4 | 101.2 to 98.8 | 102.0 to 98.0 |
| | | | 10.7 to 9.3 | 10.5 to 9.5 | 10.5 to 9.5 | 11.1 to 8.9 | 11.1 to 8.9 |
| | 190. V 100. V 10. V | off | 192.12 to 187.88 | 191.92 to 188.08 | 190.78 to 189.22 | 191.38 to 188.62 | 192.90 to 187.10 |
| | | | 101.40 to 98.60 | 101.20 to 98.80 | 100.60 to 99.40 | 101.20 to 98.8 | 102.00 to 98.00 |
| | | | 10.68 to 9.32 | 10.46 to 9.54 | 10.42 to 9.58 | 11.02 to 9.98 | 11.10 to 8.90 |
| | | | | 15 kHz | Dc | | |
| 700 V | 665. V 350. V 100. V | off | 676.6 to 653.4 | 674.5 to 655.5 | 670.5 to 659.5 | 669.5 to 660.5 | |
| | | | 359.1 to 340.9 | 357.0 to 343.0 | 354.9 to 345.1 | 354.2 to 345.8 | |
| | | | 107.1 to 92.9 | 105.0 to 95.0 | 104.4 to 95.6 | 103.7 to 96.3 | |
| | 665. V 350. V 100 V | on | 677. to 653. | 675. to 655. | 671. to 659. | 670. to 650. | |
| | | | 359. to 341. | 357. to 343. | 355. to 345. | 355. to 345. | |
| | | | 107. to 93. | 105. to 95. | 105. to 95. | 104. to 96. | |

Performance Check—DM 5010

3. Check Dc Common Mode Rejection

- a. Set the DM 5010 controls to the preliminary settings.
- b. Connect the DM 5010 input connectors to the dc voltage calibrator as shown in Fig. 5-1A.
- c. Set the dc voltage calibrator output to 100 V.
- d. CHECK—that the DM 5010 display reads ≤ 3.16 mV.
- e. Set the calibrator to a minimum output.
- f. Add a connection from the DM 5010 GUARD connector as shown in Fig. 5-1B.
- g. Set the dc voltage calibrator output to 100 V.
- h. CHECK—that the DM 5010 display reads ≤ 1.00 mV.
- i. Set the dc voltage calibrator to a minimum output and replace it with the ac voltage calibrator and counter.
- j. Set the ac voltage calibrator output to 15 V rms at 60.2, ± 0.02 Hz. Use the counter to verify the calibrator frequency.
- k. CHECK—that the absolute value of the DM 5010 display reads ≤ 0.21 mV.
- l. Remove the connection to the DM 5010 GUARD connector.

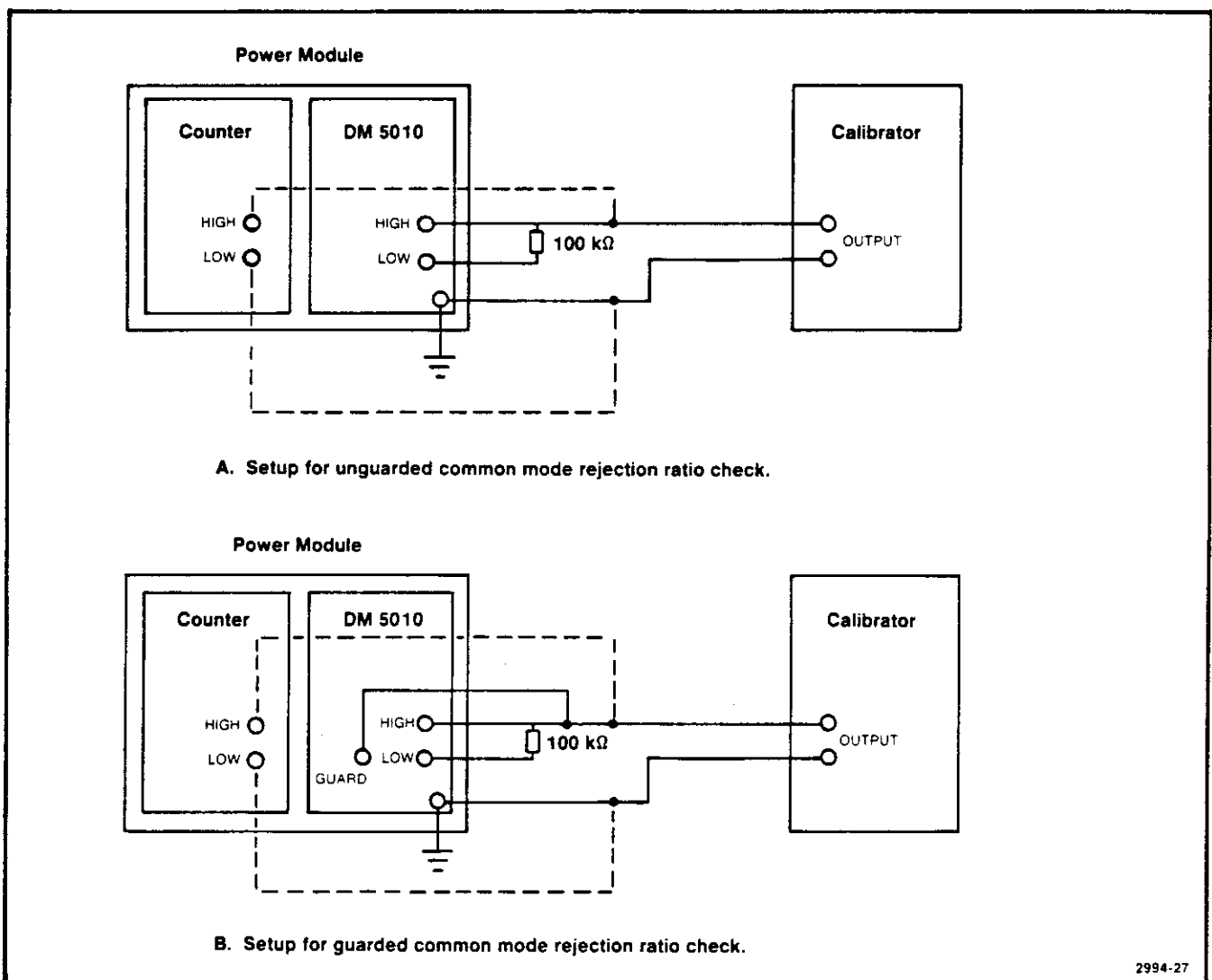

Fig. 5-1. Common mode check setup.

Performance Check—DM 5010

m. CHECK—that the absolute value of the DM 5010 display reads ≤ 2.12 mV.

n. If desired, this step may be repeated with the calibrator, counter, and GUARD connected to the LOW side of the resistor instead of the HIGH side.

o. Set the voltage calibrator to a minimum output, and remove all connections to the DM 5010.

4. Check Dc Normal Mode Rejection

a. Make certain the DM 5010 50-60 Hz jumper is in the 60 Hz position.

b. Connect the counter, ac calibrator, and DM 5010 as shown in Fig. 5-2.

c. Set the DM 5010 controls to the preliminary settings with the following exception:

| | |
|-------|------------------|
| RANGE | STEP (2 V range) |
|-------|------------------|

d. Store 0.0212 for one LIMITS constant.

e. Store -0.0212 for the other LIMITS constant.

f. Enable the COMPARE calculation.

g. Set the ac calibrator output to 1.5 V rms at the frequency listed in Table 5-5. Use the counter to verify the calibrator frequency.

h. CHECK—that the DM 5010 display reads PASS as shown in the table.

i. Repeat parts g and h for each remaining line of the table for the 60 Hz jumper position checks. Be sure to set the DM 5010 CONVERSION RATE (FAST button) as listed in the table.

j. Reposition the DM 5010 50-60 Hz jumper to the 50 Hz position.

k. CHECK—that the DM 5010 display reads PASS as shown in the table for the 50 Hz jumper position checks.

l. Remove all connections to the DM 5010.

m. Reposition the DM 5010 50-60 Hz jumper to the power module line frequency.

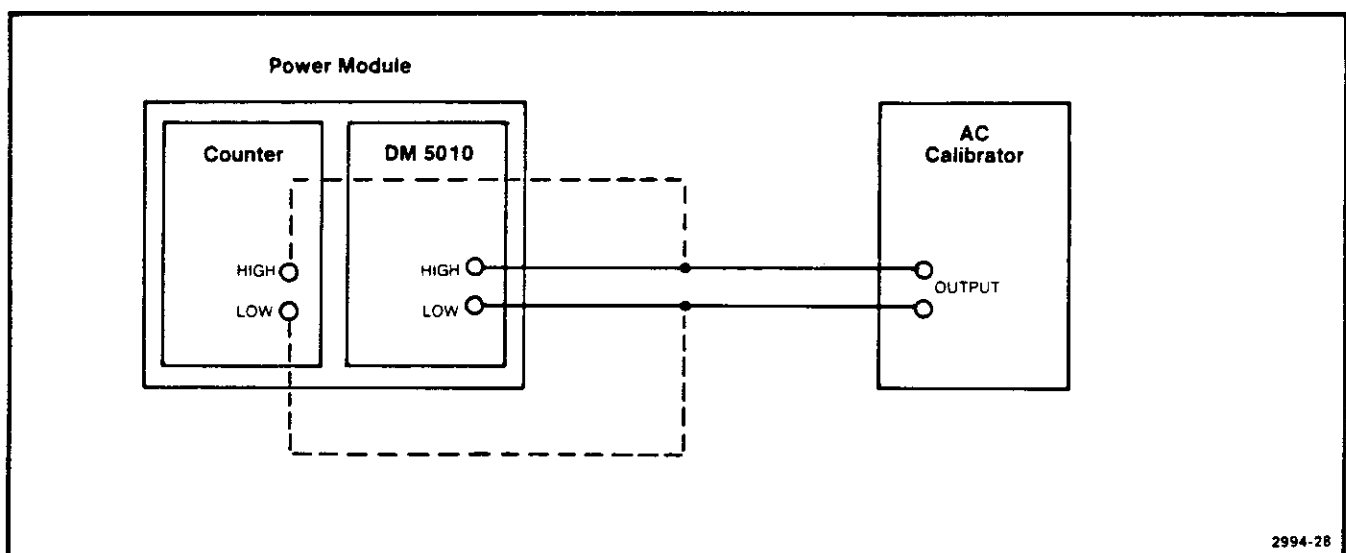

Fig. 5-2. Dc normal mode rejection setup.

Table 5-5
DC NORMAL MODE REJECTION

| 50-60 Hz Jumper Position | DM 5010 FAST | Calibrator Frequency (Hz) | Display Reading |
|--------------------------|--------------|---------------------------|-----------------|
| 60 Hz | off | 60.2, ± 0.02 | PASS |
| | on | 60.2 ± 0.02 | PASS |
| | on | 59.8, ± 0.02 | PASS |
| | off | 59.8, ± 0.02 | PASS |
| | off | 50.2, ± 0.02 | PASS |
| | off | 49.8, ± 0.02 | PASS |
| 50 Hz | on | 49.8, ± 0.02 | PASS |
| | on | 50.2, ± 0.02 | PASS |

5. Ohms Accuracy

a. Set the DM 5010 front-panel controls to the preliminary control settings with the following exception:

OHMS on

b. Connect a shorting plug between the DM 5010 HIGH and LOW input connectors.

c. CHECK—that the display reads within the limits listed in Table 5-6, at each conversion rate.

d. Set the DM 5010 front panel controls to the 200 Ω range and normal conversion rate. Press the NULL button. Remove the shorting plug and connect the decade resistance box to the DM 5010 input connectors using a coaxial cable with less than 0.3 Ω . See Fig. 5-3A.

e. Set the decade box resistance to the value listed in Table 5-7.

f. CHECK—that the display reads within the limits listed in the table.

g. Set the DM 5010 CONVERSION RATE as shown in the next line of the table.

h. CHECK—that the display reads within the limits listed in the table.

i. Set the DM 5010 range, CONVERSION RATE, and the decade box resistance as listed in the next line of the table.

j. Repeat parts f through i for the remaining lines of the table, except change the equipment setup as shown in Fig. 5-3B for the 20 M Ω range checks.

k. Remove all connections to the DM 5010.

Table 5-6
OHMS OFFSET ACCURACY

| DM 5010 Range | DM 5010 FAST | Display Limits | |
|----------------|--------------|--------------------------------------|---|
| | | Ambient Temp. Range +18 to +28 °C | Ambient Temp. Range 0 to +18 °C, +28 to +50 °C |
| 200 Ω | off | $\pm 0.03 \Omega^a$ | $\pm 0.12 \Omega^a$ |
| | on | $\pm 0.1 \Omega^a$ | $\pm 0.2 \Omega^a$ |
| 2 k Ω | on | $\pm .001 \text{ k}\Omega$ | $\pm .002 \text{ k}\Omega$ |
| | off | $\pm .0002 \Omega^b$ | $\pm .0007 \text{ k}\Omega^b$ |
| 20 k Ω | off | $\pm 0.002 \text{ k}\Omega$ | $\pm 0.007 \text{ k}\Omega$ |
| | on | $\pm 0.01 \text{ k}\Omega$ | $\pm 0.02 \text{ k}\Omega$ |
| 200 k Ω | on | $\pm 0.1 \text{ k}\Omega$ | $\pm 0.2 \text{ k}\Omega$ |
| | off | $\pm 0.02 \text{ k}\Omega$ | $\pm 0.07 \text{ k}\Omega$ |
| 2 M Ω | off | $\pm .0002 \text{ M}\Omega$ | $\pm .0007 \text{ M}\Omega$ |
| | on | $\pm .001 \text{ M}\Omega$ | $\pm .002 \text{ M}\Omega$ |
| 20 M Ω | on | $\pm 0.01 \text{ M}\Omega$ | $\pm 0.01 \text{ M}\Omega$ |
| | off | $\pm 0.001 \text{ M}\Omega$ | $\pm 0.002 \text{ M}\Omega$ |

^a. With NULL, if NULL is not used add $\pm 0.2 \Omega$.

^b. With NULL, if NULL is not used add $\pm 0.0002 \text{ k}\Omega$.

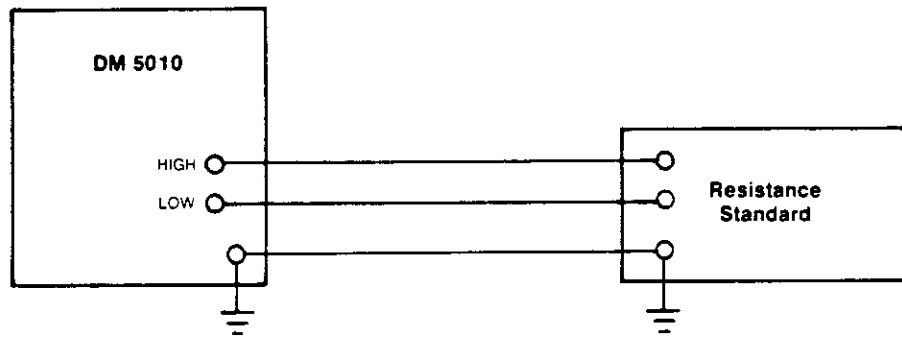

A. Initial ohms accuracy setup.

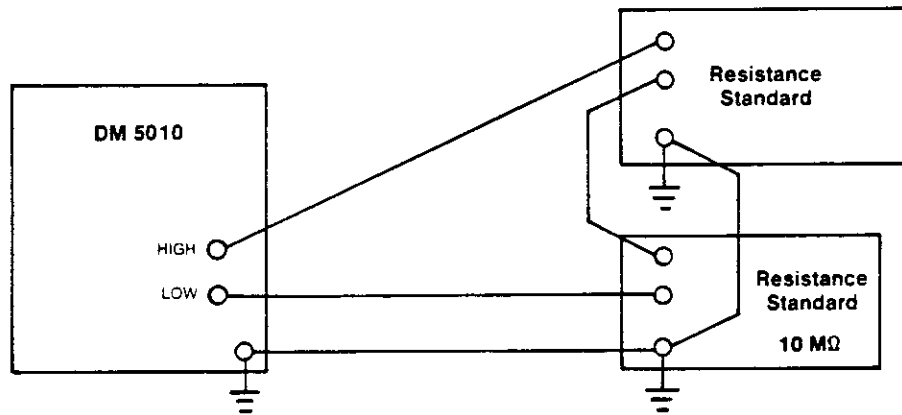

B. 20 MΩ range accuracy setup.

2994-29

Fig. 5-3. Ohms accuracy setup.

Table 5-7
OHMS GAIN ACCURACY

| DM 5010 Range | Resistance Standard | DM 5010 FAST | Display Limits | |
|-------------------------|-------------------------|-----------------------------------|-------------------------------------|---|
| | | | Ambient Temp. Range +18 to +28°C | Ambient Temp. Range 0 to +18°C, +28 to +50°C |
| 200 Ω | 0.00019 MΩ | off | $R_{FS} \pm 0.06 \Omega$ | $R_{FS} \pm 0.24 \Omega$ |
| | | on | $R_{FS} \pm 0.2 \Omega$ | $R_{FS} \pm 0.4 \Omega$ |
| 2 kΩ | 0.00019 MΩ | on | $R_{FS} \pm .001 \text{ k}\Omega$ | $R_{FS} \pm .002 \text{ k}\Omega$ |
| | | off | $R_{FS} \pm .0002 \text{ k}\Omega$ | $R_{FS} \pm .0008 \text{ k}\Omega$ |
| | 0.00190 MΩ | off | $R_{FS} \pm .0005 \text{ k}\Omega$ | $R_{FS} \pm .0019 \text{ k}\Omega$ |
| | | on | $R_{FS} \pm .002 \text{ k}\Omega$ | $R_{FS} \pm .004 \text{ k}\Omega$ |
| 20 kΩ | 0.00190 MΩ | on | $R_{FS} \pm .01 \text{ k}\Omega$ | $R_{FS} \pm 0.02 \text{ k}\Omega$ |
| | | off | $R_{FS} \pm 0.002 \text{ k}\Omega$ | $R_{FS} \pm .008 \text{ k}\Omega$ |
| | 0.01900 MΩ | off | $R_{FS} \pm 0.005 \text{ k}\Omega$ | $R_{FS} \pm 0.019 \text{ k}\Omega$ |
| | | on | $R_{FS} \pm 0.02 \text{ k}\Omega$ | $R_{FS} \pm .04 \text{ k}\Omega$ |
| 200 kΩ | 0.01900 MΩ | on | $R_{FS} \pm .1 \text{ k}\Omega$ | $R_{FS} \pm .2 \text{ k}\Omega$ |
| | | off | $R_{FS} \pm 0.02 \text{ k}\Omega$ | $R_{FS} \pm .08 \text{ k}\Omega$ |
| | 0.19000 MΩ | off | $R_{FS} \pm 0.05 \text{ k}\Omega$ | $R_{FS} \pm 0.19 \text{ k}\Omega$ |
| | | on | $R_{FS} \pm 0.2 \text{ k}\Omega$ | $R_{FS} \pm .4 \text{ k}\Omega$ |
| 2 MΩ | 0.19000 MΩ | on | $R_{FS} \pm .001 \text{ M}\Omega$ | $R_{FS} \pm .003 \text{ M}\Omega$ |
| | | off | $R_{FS} \pm .0004 \text{ M}\Omega$ | $R_{FS} \pm .0017 \text{ M}\Omega$ |
| | 1.90000 MΩ | off | $R_{FS} \pm .0021 \text{ M}\Omega$ | $R_{FS} \pm .0110 \text{ M}\Omega$ |
| | | on | $R_{FS} \pm .003 \text{ M}\Omega$ | $R_{FS} \pm .012 \text{ M}\Omega$ |
| 20 MΩ | 1.90000 MΩ | on | $R_{FS} \pm .03 \text{ M}\Omega$ | $R_{FS} \pm .04 \text{ M}\Omega$ |
| | | off | $R_{FS} \pm .004 \text{ M}\Omega$ | $R_{FS} \pm .016 \text{ M}\Omega$ |
| | 0.00000 MΩ ^a | off | $R_{FS} \pm .016 \text{ M}\Omega$ | $R_{FS} \pm .077 \text{ M}\Omega$ |
| | | on | $R_{FS} \pm .11 \text{ M}\Omega$ | $R_{FS} \pm .017 \text{ M}\Omega$ |
| | | on | $R_{FS} \pm .20 \text{ M}\Omega$ | $R_{FS} \pm .31 \text{ M}\Omega$ |
| 0.00000 MΩ ^a | off | $R_{FS} \pm .030 \text{ M}\Omega$ | $R_{FS} \pm .145 \text{ M}\Omega$ | |

^aSR1 10 MΩ standard resistor in series with the DB62.

NOTE

The rear interface ohms offset and accuracy checks need not be made unless the instrument is used for measurements via the rear-interface connections.

6. Diode Test Check

- Set the DM 5010 controls to the preliminary settings.
- Connect a 604 Ω resistor between the DM 5010 HIGH and LOW input connectors.
- Press the DIODE TEST button (on).
- CHECK—that the display reads between 0.5484 V and 0.6054 V.
- Remove the resistor.

7. Rear Interface Ohms Offset Check

For this check, short the power module connections to the DM 5010 rear-interface pins 28B (Hi) and 28A (Lo) on the ADC board (A17). Access to these pins is most easily made using a TM 5000-Series, Option 02 power module.

- Set the DM 5010 controls to the preliminary control settings with the following exceptions:

| | |
|------------|----|
| OHMS | on |
| REAR INPUT | on |

Performance Check—DM 5010

b. CHECK—that the DM 5010 display reads between -0 and -0.5Ω .

c. Remove the short between the power module connections to the DM 5010 rear-interface input connector pins.

8. Rear Interface Accuracy Checks

To verify the accuracy of the DCV, ACV, ACV+DCV, and OHMS modes via the DM 5010 rear interface, follow the steps outlined in the performance check for the front-panel input connectors, but apply the voltages and resistances to the DM 5010 rear interface pins pins 28B (Hi) and 28A (Lo) on the ADC board (A17) via the power module connections.

NOTE

The output cable fixture from the calibrating sources to the rear interface pins may require modification to accommodate accuracy checks via the DM 5010 rear interface.

Press the DM 5010 REAR INPUT button to select rear interface input.



Do not exceed the maximum input voltages specified for rear interface input.

When rear-interface accuracy checks have been completed, remove all connections to the DM 5010.

9. GPIB Communication Check

a. Refer to the talker-listener programs in the Programming section of this manual. Using one of these programs, send commands to the DM 5010 and observe the front-panel changes. Send SET? and note the data returned to the controller.

b. CHECK—that the DM 5010 front panel correctly displays setting changes as sent and returns the correct setting information when queried.

c. Remove all connections.

This completes the performance check for the DM 5010.

PERFORMANCE CHECK SUMMARY SHEET

Date _____

Serial Number _____ Tested by _____

| Step | Description | Minimum | Measured | Maximum |
|------|-------------|---------|----------|---------|
| | | | | |
| | | | | |
| | | | | |
| | | | | |
| | | | | |
| | | | | |
| | | | | |
| | | | | |
| | | | | |
| | | | | |
| | | | | |
| | | | | |
| | | | | |
| | | | | |
| | | | | |
| | | | | |
| | | | | |
| | | | | |
| | | | | |
| | | | | |
| | | | | |
| | | | | |
| | | | | |
| | | | | |
| | | | | |
| | | | | |
| | | | | |

Permission is granted to reproduce this summary sheet for customers data logging purposes only. Reproduction for commercial purposes is expressly forbidden.

ADJUSTMENT PROCEDURE

Introduction

This procedure should be performed if the instrument fails to meet the performance requirements of the electrical characteristics listed in the Specification section of this manual. To ensure continued instrument accuracy, adjustment should be performed every 1000 hours of operation or every six months if used infrequently. Adjustment is also recommended following instrument repair or modification. Adjustments must be made at an ambient temperature between +21°C to +25°C. Allow thirty minutes warm-up time before beginning adjustments (sixty minutes after exposure to or storage in high humidity environment).

The recommended interval for battery replacement is approximately every two years. Performance of the Adjustment Procedure is necessary after battery replacement to restore the calibration factors to memory. See the Maintenance

section of this manual for battery replacement information.

Services Available

Tektronix, Inc. provides complete instrument repair and adjustment at local field service centers and at the factory service center. Contact your local Tektronix Field Office or representative for further information.

Test Equipment Required

The test equipment listed in Table 6-1, or equivalent, is recommended for adjustment of the DM 5010. Specifications given for the test equipment are the minimum necessary for accurate instrument adjustment. All test equipment is assumed to be correctly calibrated and operating within specification.

Table 6-1
TEST EQUIPMENT LIST

| Description | Minimum Requirements | Performance Check Step | Recommended Equipment |
|-----------------------------|---|------------------------|--|
| TM 5000-Series Power Module | | all | TEKTRONIX TM 5003, Opt. 02 |
| DC voltage calibrator | 200 mV: $\pm(0.0038\%$ of rdng + 0.0025% of range) 2 V-200 V: $\pm(0.0038\%$ of rdng + 0.0013% of range) 1000 V: $\pm(0.005\%$ of rdng + 0.0025% of range) | 2 | Fluke 335D Dc Voltage Standard |
| Ac voltage calibrator | 200 mV through 200 V: 10-20 Hz: $\pm(0.20\%$ of rdng + 0.08% of range) 20-100 Hz: $\pm(0.20\%$ of rdng + 0.05% of range) 100 Hz-20 kHz: $\pm(0.05\%$ of rdng + 0.05% of range) 20-100 kHz: $\pm(0.25\%$ of rdng + 0.12% of range) | 6, 7 | Fluke 5200A Ac Calibrator, and Fluke 5215A Power Amplifier |

Table 6-1 (cont)

| Description | Minimum Requirements | Performance Check Step | Recommended Equipment |
|-----------------------------------|---|------------------------|---|
| | 700 V: 10-20 Hz: $\pm(0.20\%$ of rdng + 0.22% of range) 20-100 Hz: $\pm(0.20\%$ of rdng + 0.15% of range) 100 Hz-15 kHz: $\pm(0.05\%$ of rdng + 0.15% of range) | | |
| Resistance standard ^a | 200 Ω : $\pm(0.0038\%$ of rdng + 0.0038% of range) 2 k-200 k Ω : $\pm(0.0038\%$ of rdng + 0.0025% of range) 2 M Ω : $\pm(0.025\%$ of rdng + 0.0025% of range) 20 M Ω : $\pm(0.038\%$ of rdng + 0.0012% of range) | 4 | Electro Scientific Industries, Inc. DB 62 Dekabox and SR1 10 M Ω Standard Resistor |
| Digital Voltmeter | Range: 0 to 1 kV. Accuracy: $\pm(0.05\%$ of rdng + 0.02% of full scale) | 5 | TEKTRONIX DM 501A Digital Multimeter ^b |
| Flexible Extender cable (2 ea) | | 5, 6, 7 | Tektronix Part No. 067-0645-02 |

^aResistance of Dekabox and interconnect cable must be known to the accuracy listed in Table 6-1 for each point adjusted in Step 4.

^bRequires a TM 500/5000-Series power module.

Preparation

Before adjustments can be performed, the internal CAL jumper must be repositioned. For access to the jumper, remove the instrument's left side cover by turning the two plastic fasteners. The jumper is located in the lower rear corner of the CPU board (A14). See Fig. 10-1 in the pullout pages of this manual. Reposition the CAL jumper, P1132, to the CAL position. Also, make certain the 50-60 Hz jumper is positioned to match the power module line frequency. This jumper is also located on the CPU board. Replace the side cover.

Since the DCV and OHMS adjustments are more sensitive to temperature variations, these adjustments are made with the instrument operating in the power module. Install the DM 5010 in the power module, turn on the power module and allow warm-up time before beginning adjustments.

WARNING

Dangerous voltages may be encountered in the following steps. Caution must be exercised. Do not contact the output connectors of the voltage calibrator, the input terminals of the DM 5010, or the internal circuitry of the DM 5010. Also, do not contact the internal adjustments, since they may be at the DM 5010 input potential; use only an insulated adjustment tool for adjustments.

Preliminary Control Settings

| | |
|-------------------|---------------------|
| DCV | on |
| NULL | off |
| LOW FREQ RESPONSE | off |
| RANGE | STEP (200 mV range) |
| TRIGGER MODE | RUN on |
| CONVERSION RATE | FAST off |
| CALCULATIONS | all off |
| REAR INPUT | off |

1. Adjust the DCV Offset Calibration Factors

a. Set the DM 5010 front-panel controls to the preliminary settings.

b. Connect the dual banana shorting plug between the DM 5010 HIGH and LOW INPUT connectors.

c. Press ENTER.

d. CHECK—that the display reads as shown in Table 6-2, ± 1 in the least significant digit (LSD).

e. Set the range and FAST button as shown in the next line of the table.

f. Repeat parts c through e for each succeeding line in the table.

g. Remove the shorting plug.

Table 6-2
DCV OFFSET CALIBRATION FACTORS

| DM 5010 Range | DM 5010 FAST | Press | Display Reading |
|---------------|--------------|-------|-----------------|
| 200 mV | off | ENTER | 0.00 mV |
| | on | ENTER | 0.0 mV |
| 2 V | on | ENTER | .000 V |
| | off | ENTER | .0000 V |
| 20 V | off | ENTER | 0.000 V |
| | on | ENTER | 0.00 V |
| 200 V | on | ENTER | 0.0 V |
| | off | ENTER | 0.00 V |
| 1000 V | off | ENTER | 0.0 V |
| | on | ENTER | 0. V |

2. Adjust the DCV Gain Calibration Factors

a. Set the DM 5010 controls to the preliminary control settings.

b. Connect the dc voltage calibrator through appropriate cables and connectors to the DM 5010 HIGH and LOW connectors.

c. Set the dc voltage calibrator output to 190 mV dc.

d. Press ENTER.

e. CHECK—that the display reads as shown in Table 6-3, ± 1 in the LSD.

f. Set the FAST button as shown in the table.

g. Press ENTER.

h. CHECK—that the display reads as shown in the table, ± 1 in the LSD.

Table 6-3
DCV GAIN CALIBRATION FACTORS

| DM 5010 Range | Dc Calibrator Voltage | DM 5010 FAST | Press | Display Reading |
|---------------|-----------------------|--------------|-------|-----------------|
| 200 mV | 190 mV dc | off | ENTER | 190.00 mV |
| | | on | ENTER | 190.0 mV |
| 2 V | 1.9 Vdc | on | ENTER | 1.900 V |
| | | off | ENTER | 1.9000 V |
| 20 V | 19 Vdc | off | ENTER | 19.000 V |
| | | on | ENTER | 19.00 V |
| 200 V | 190 Vdc | on | ENTER | 190.0 V |
| | | off | ENTER | 190.00 V |
| 1000 V | 1000 Vdc | off | ENTER | 1000.V |
| | | on | ENTER | 1000.0 V |

- i. Set the DM 5010 range as shown in the table.
- j. Set the dc calibrator output to the next value in the table.
- k. Repeat parts d through j for each succeeding line of the table.

NOTE

Avoid over-ranging the DM 5010 while performing the adjustment procedure. Should over-range occur, allow several minutes for stabilization before proceeding with adjustments.

- l. Set the dc calibrator to 0 Vdc and remove the connections to the DM 5010.

3. Adjust the Ohms Offset Calibration Factors

- a. Set the DM 5010 controls to the preliminary settings with the following exception:
- | | |
|------|----|
| OHMS | on |
|------|----|
- b. Connect the dual banana shorting plug between the DM 5010 HIGH and LOW INPUT connectors.
- c. Press ENTER.

- d. CHECK—that the display reads as shown in Table 6-4, ± 1 in the LSD.
- e. Set the range and FAST button as listed in the next line of the table.
- f. Repeat parts c through e for each succeeding line in the table.
- g. Remove the shorting plug.

Table 6-4
OHMS OFFSET CALIBRATION FACTORS

| DM 5010 Range | DM 5010 FAST | Press | Display Reading |
|----------------|--------------|-------|------------------|
| 200 Ω | off | ENTER | 0.00 |
| | on | ENTER | 0.0 |
| 2 k Ω | on | ENTER | .000 k Ω |
| | off | ENTER | .0000 k Ω |
| 20 k Ω | off | ENTER | 0.000 k Ω |
| | on | ENTER | 0.00 k Ω |
| 200 k Ω | on | ENTER | 0.0 k Ω |
| | off | ENTER | 0.00 k Ω |
| 2 M Ω | off | ENTER | .0000 M Ω |
| | on | ENTER | .000 M Ω |
| 20 M Ω | on | ENTER | 0.00 M Ω |
| | off | ENTER | 0.000 M Ω |

4. Adjust the Ohms Gain Calibration Factors

NOTE

The actual resistance of the precision resistance, including the interconnecting cable, must be known for each calibration point before this step can be performed. For convenience, write the actual resistance in the blank columns (Table 6-5), for each calibration point.

a. Set the DM 5010 controls to the preliminary settings with the following exception:

OHMS on

b. Connect the decade box to the DM 5010 input connectors as shown in Fig. 6-1A.

c. Set the decade box resistance to the value listed in Table 6-5.

d. Press the keypad numeric and decimal point buttons listed in the table for the applied resistance value, beginning with the most significant digit. (For example; for 190 Ω press 1, 9, 0, and ENTER; for 190 k Ω press 1, 9, 0, 0, 0, 0, and ENTER).

e. Press ENTER.

f. CHECK—that the display reads as shown in the table, ± 1 in the LSD.

g. Repeat parts c through f for the remaining lines of Table 6-5 except change the equipment setup as shown in Fig. 6-1B for the 20 M Ω adjustments.

h. Remove all connections to the DM 5010.

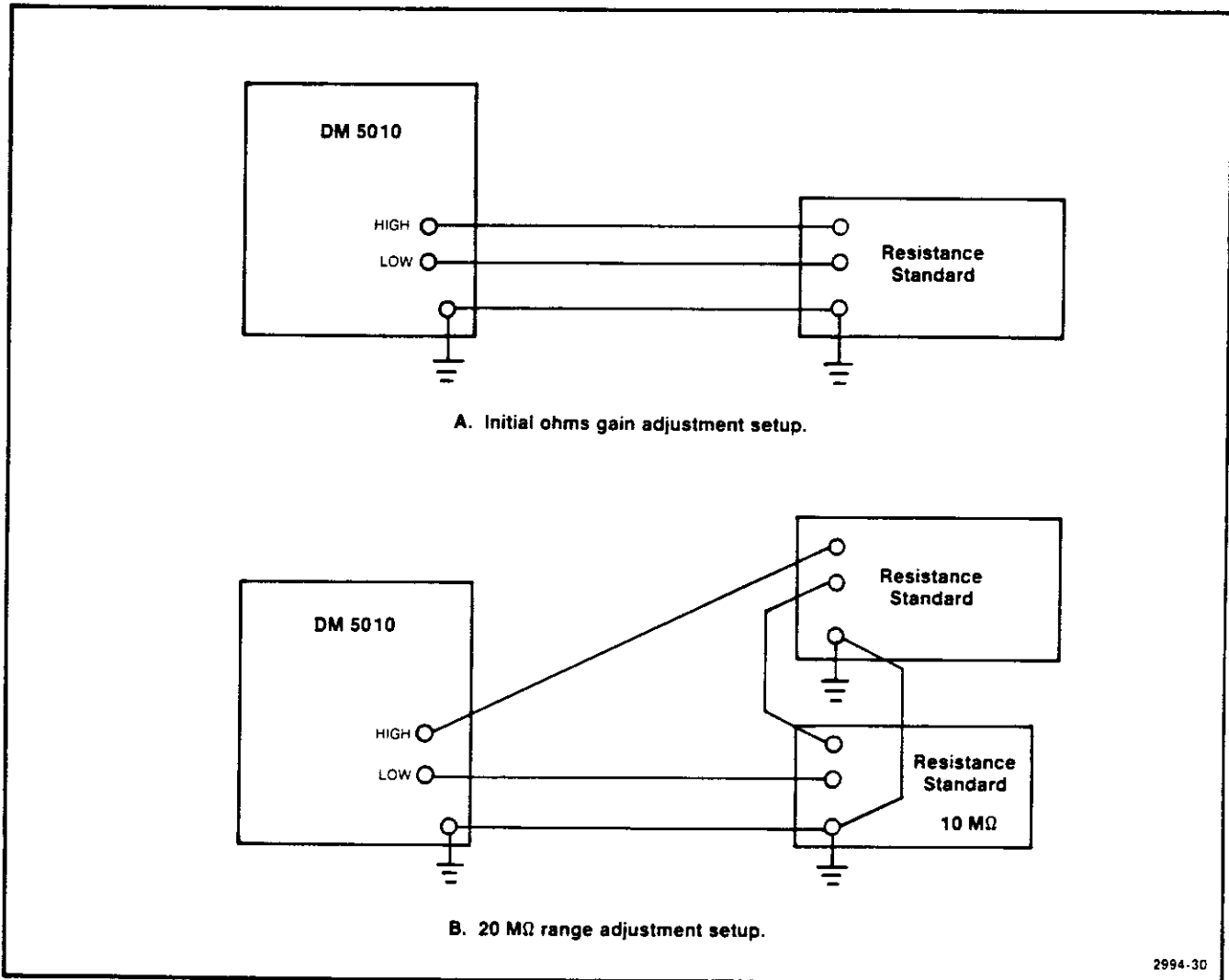

Fig. 6-1. Ohms adjustment setup.

Table 6-5
OHMS GAIN CALIBRATION FACTORS

| DM 5010 Range | DM 5010 FAST | Resistance Standard | ENTER applied resistance | Display Reading (entered resistance) |
|-----------------|--------------|---------------------|--------------------------|--------------------------------------|
| 200 Ω | off | 0.00019 M Ω | | |
| | on | 0.00019 M Ω | | |
| 2 k Ω | on | 0.00190 M Ω | | |
| | off | 0.00190 M Ω | | |
| 20 k Ω | off | 0.01900 M Ω | | |
| | on | 0.01900 M Ω | | |
| 200 k Ω | on | 0.19000 M Ω | | |
| | off | 0.19000 M Ω | | |
| 2 M Ω | off | 1.90000 M Ω | | |
| | on | 1.90000 M Ω | | ± 1 in LSD |
| 20 M Ω^a | on | 9.00000 M Ω | | ± 3 in LSD |
| | off | 9.00000 M Ω | | |

^aConnect SR1 10M standard in series with the DB 62. To minimize the effect of noise, make physical contact with the DM 5010 chassis ground terminal.

5. Adjust the ACV Offsets

a. Turn off the power module, remove the DM 5010, and connect the DM 5010 rear-interface connectors to the power module via the flexible extender cables. Turn on the power module.

b. Connect a shorting plug between the HIGH and LOW input connectors.

c. Set the DM 5010 controls to the preliminary settings with the following exceptions:

ACV+DCV on

d. Set the DM 501A to measure 200 mV dc.

e. Connect the DM 501A low connector to the DM 5010 Lo test point (TP1701) and the high connector to the DM 5010 Atten Out test point (TP1503). Refer to Fig. 10-1 for test point locations.

f. ADJUST—the Atten Offset (R1601), using an insulated adjustment tool, for a DM 501A reading of 0 ± 0.05 mV.

g. Move the DM 501A high lead to the DM 5010 Amp Out test point (TP1201).

h. ADJUST—the Amp Offset (R1305) for a DM 501A reading of 0 ± 0.50 mV.

i. Disconnect the DM 501A leads and remove the shorting plug.

6. Adjust ACV Gain Calibration Factors

a. Set the DM 5010 controls to the preliminary settings with the following exception:

ACV+DCV on

b. Connect the ac calibrator to the DM 5010 HIGH and LOW input connectors.

c. Set the 200 Hz ac calibrator output to the voltage listed in the table.

d. Press ENTER.

e. CHECK—that the display reads as listed in Table 6-6.

f. Set the DM 5010 range and FAST button as listed in the next line of the table.

g. Repeat parts c through f for each remaining line of the table. Use the power amplifier for the 200 V and 700 V range adjustments.

h. Set the calibrator output to a minimum level and remove all connections to the DM 5010.

7. Adjust the Ac Frequency Compensation

a. Set the DM 5010 controls to the preliminary settings with the following exceptions:

| | |
|---------|--------------------|
| ACV+DCV | on |
| RANGE | STEP (200 V range) |

b. Connect the ac calibrator to the DM 5010 HIGH and LOW input connectors.

c. Set the ac calibrator output to 190.00 V at 20 kHz, ± 200 Hz.

Table 6-6
ACV GAIN CALIBRATION FACTORS

| DM 5010 Range | Ac Calibrator (200 Hz) | DM 5010 FAST | Press | Display Reading |
|---------------|------------------------|--------------|-------|----------------------|
| 200 mV | 19 mV | off | ENTER | 19.00 |
| | | on | ENTER | 19.0 |
| | 190 mV | on | ENTER | 190.0 |
| | | off | ENTER | 190.00 |
| 2 V | 190 mV | off | ENTER | .1900 |
| | | on | ENTER | .190 |
| | 1.9 V | on | ENTER | 1.900 |
| | | off | ENTER | 1.9000 |
| 20 V | 1.9 V | off | ENTER | 1.900 |
| | | on | ENTER | 1.90 |
| | 19 V | on | ENTER | 19.00 |
| | | off | ENTER | 19.000 |
| 200 V | 19 V | off | ENTER | 19.00 |
| | | on | ENTER | 19.0 |
| | 190 V | on | ENTER | 190.0 |
| | | off | ENTER | 190.00 |
| 700 V | 190 V | off | ENTER | 190.0 |
| | | on | ENTER | 190. |
| | 700 V | on | ENTER | 700. |
| | | off | ENTER | 700.0 ± 3 in LSD |

Adjustment Procedure—DM 5010

d. ADJUST—the 200 V H.F. Comp. (C1607) for a DM 5010 display reading of 190.00, ± 0.02 V, using an insulated adjustment tool. Refer to Fig. 10-1. After adjustment, recheck the DM 5010 display reading and readjust, if necessary.

NOTE

If C1607 approaches the end of its adjustment range, turn off the power module, and remove the RMS board (A16). Adjust C1605 several complete turns in the same direction required for additional range by C1607. Reinstall the board, turn on the power module, and readjust C1607.

e. Set the ac calibrator output to 1.9000 V at 20 kHz, ± 200 Hz.

f. Set the DM 5010 range to the 2 V range.

g. ADJUST—the 2 V/200 mV H.F. Comp. (C1503) for a display reading of 1.9000, ± 0.0002 V.

h. Set the DM 5010 to the 20 V range.

i. Set the ac calibrator output to 19.000 V at 20 kHz, ± 200 Hz.

j. ADJUST—the 20 V H.F. Comp. (C1403) for a display reading of 19.0000, ± 0.005 V.

k. Set the DM 5010 to the 200 V range and repeat parts b through j to verify that the adjustments have not changed.

l. Set the ac calibrator output to a minimum level and remove connections to the DM 5010.

m. Turn off the power module and reposition the CAL jumper to the normal position. Replace the cover.

This completes the adjustment procedure.

MAINTENANCE

This section of the manual describes preparation for use (internal jumper and switch settings) and provides general maintenance and troubleshooting information.

CAUTION

To prevent damage to the DM 5010, turn off the power module before installing or removing the instrument. Do not use excessive force to install or remove.

PREPARATION FOR USE

Setting the GPIB Address Switches

For access to the GPIB address switches, remove the DM 5010 left side cover. Five of these switches (A5 through A1) set the decimal value of the primary GPIB address for the DM 5010. Refer to Fig. 7-1. Setting the primary address to 31 untalks and unlistens the DM 5010; the instrument does not respond to GPIB commands. Refer to Table 7-1 for switch settings.

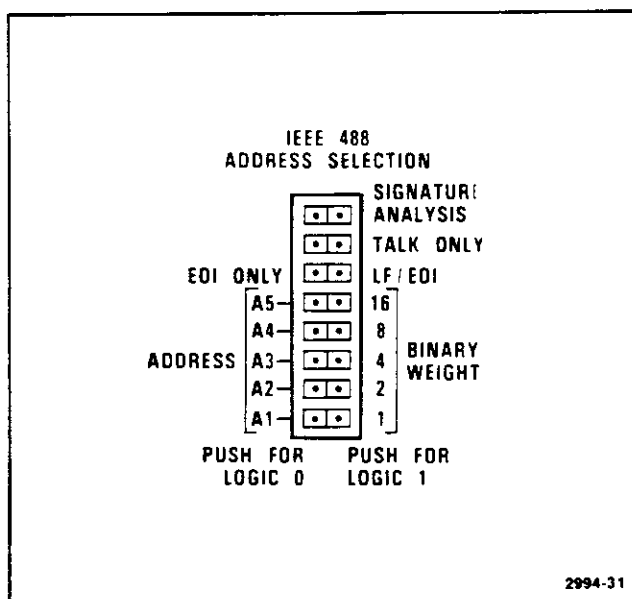

Fig. 7-1. GPIB address and message terminator switches.

Table 7-1
IEEE 488 (GPIB) PRIMARY ADDRESSES

| A5 | A4 | A3 | A2 | A1 | Primary Address |
|----|----|----|----|----|-----------------|
| 0 | 0 | 0 | 0 | 0 | 0 |
| 0 | 0 | 0 | 0 | 1 | 1 |
| 0 | 0 | 0 | 1 | 0 | 2 |
| 0 | 0 | 0 | 1 | 1 | 3 |
| 0 | 0 | 1 | 0 | 0 | 4 |
| 0 | 0 | 1 | 0 | 1 | 5 |
| 0 | 0 | 1 | 1 | 0 | 6 |
| 0 | 0 | 1 | 1 | 1 | 7 |
| 0 | 1 | 0 | 0 | 0 | 8 |
| 0 | 1 | 0 | 0 | 1 | 9 |
| 0 | 1 | 0 | 1 | 0 | 10 |
| 0 | 1 | 0 | 1 | 1 | 11 |
| 0 | 1 | 1 | 0 | 0 | 12 |
| 0 | 1 | 1 | 0 | 1 | 13 |
| 0 | 1 | 1 | 1 | 0 | 14 |
| 0 | 1 | 1 | 1 | 1 | 15 |
| 1 | 0 | 0 | 0 | 0 | 16 |
| 1 | 0 | 0 | 0 | 1 | 17 |
| 1 | 0 | 0 | 1 | 0 | 18 |
| 1 | 0 | 0 | 1 | 1 | 19 |
| 1 | 0 | 1 | 0 | 0 | 20 |
| 1 | 0 | 1 | 0 | 1 | 21 |
| 1 | 0 | 1 | 1 | 0 | 22 |
| 1 | 0 | 1 | 1 | 1 | 23 |
| 1 | 1 | 0 | 0 | 0 | 24 |
| 1 | 1 | 0 | 0 | 1 | 25 |
| 1 | 1 | 0 | 1 | 0 | 26 |
| 1 | 1 | 0 | 1 | 1 | 27 |
| 1 | 1 | 1 | 0 | 0 | 28 |
| 1 | 1 | 1 | 0 | 1 | 29 |
| 1 | 1 | 1 | 1 | 0 | 30 |
| 1 | 1 | 1 | 1 | 1 | 31 |

Message Terminator Switch Setting

The EOI ONLY switch selects the DM 5010 message terminator. For access to this switch, remove the instrument's left side cover. The switch is located on the CPU board (A14). Refer to Fig. 7-1. Operation of the DM 5010 with either switch position is described in Section 3 under Messages and Communication Protocol.

Talk Only Switch Setting

The Talk Only switch is one of the bank of eight switches located on the CPU board (A14). Remove the instrument's left side cover for access to this switch. Refer to Fig. 7-1. Setting the Talk Only switch to logic 1 selects the Talk Only mode.

Using the Rear Interface Connections

For rear interface connector pin assignments, see Tables 10-13, 10-14, and 10-15 in the pullout pages of this manual.

Rear-interface pins 28B (Hi) and 28A (Lo) on the ADC board (A17) are the input connections for measurements via the rear interface.

A negative-going TTL signal may be used to trigger instrument measurements via rear interface connections to the Isolation board (A15). Use of this function requires moving a jumper on the CPU board (A14). For access to the jumper, remove the instrument's left side cover. Connect pins 2 and 3 of J1733 using its EXTRIG jumper, P1733. Refer to Fig. 10-1. Apply the EXTRIG signal to the Isolation board rear interface pins 16A and 16B (Ground).

GENERAL MAINTENANCE

Rear Circuit Board Removal

To remove the CPU, Isolation, RMS, or ADC boards, turn off the power module and remove the plug-in. Turn the two plastic fasteners on each side cover and remove the covers. Next, remove the four screws on the instrument back plate and remove the plate. See Fig. 7-2. Then, remove the retainer bar. Carefully pull the selected board toward the rear of the instrument.

NOTE

*Before removing the CPU board, unplug the ribbon cable connector from the Front Panel Driver board.
Before removing the ADC board, remove the screw on the front panel between the input connectors.*

A calibration fixture (Tektronix Part No. 067-1052-00) contains a board extractor for disengaging these boards. It also contains two extender boards designed for operating boards outside the instrument.

To reinstall boards, carefully align the board edges in the guides attached to the top and bottom instrument covers. Press the board firmly to seat it in the Main Interconnect board connectors. When inserting the ADC board, slide the board in until the input connectors contact the front panel. From the front of the instrument, insert a small screwdriver into the front panel connector holes and carefully align the input connectors with the holes while maintaining slight pressure on the back edge of the board. When properly aligned, press the board in firmly.

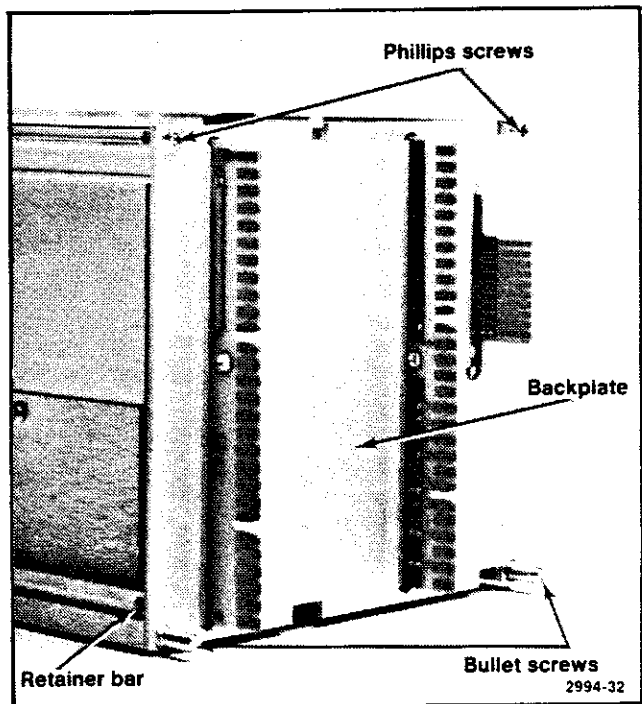

Fig. 7-2. Backplate and retainer bar removal.

Front-Panel Board Removal

To remove the Front Panel and Front Panel Driver board assembly, first remove the instrument side covers and back plate. Remove the front panel screw between the input connectors and remove the ADC board. Refer to Fig. 7-3. It is necessary to disengage the latch before removing the front panel boards. To disengage the latch, use a small screwdriver to push forward slightly on the rear latch (1) just in front of the spring. Press down on the latch knob to raise the latch knob extension at the point where the two latch pieces engage. While holding the latch knob down, push up on the front panel latch piece at the point of engagement (2) to disengage the two pieces. Then, pull the latch knob out.

CAUTION

Do not install the plug-in in the power module while the latch is disassembled. Removal of the plug-in without use of the latch can be extremely difficult.

Next, remove the two screws near the front of the instrument top cover (see Fig. 7-4) and remove the cover. Then, remove the other front panel screw and the chassis ground terminal. Pull forward to remove the front panel assembly. Disconnect the ribbon cable from the Front Panel Driver board.

To remove the front panel from the board assembly, remove the five screws on the Front Panel board. To separate the two circuit boards, carefully pull the boards apart, maintaining nearly equal separation until the interconnecting pins disengage. Reassemble in the reverse order.

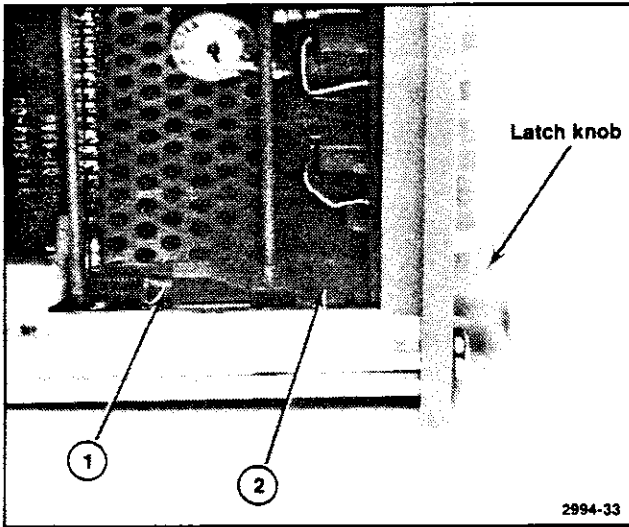

Fig. 7-3. Latch disassembly.

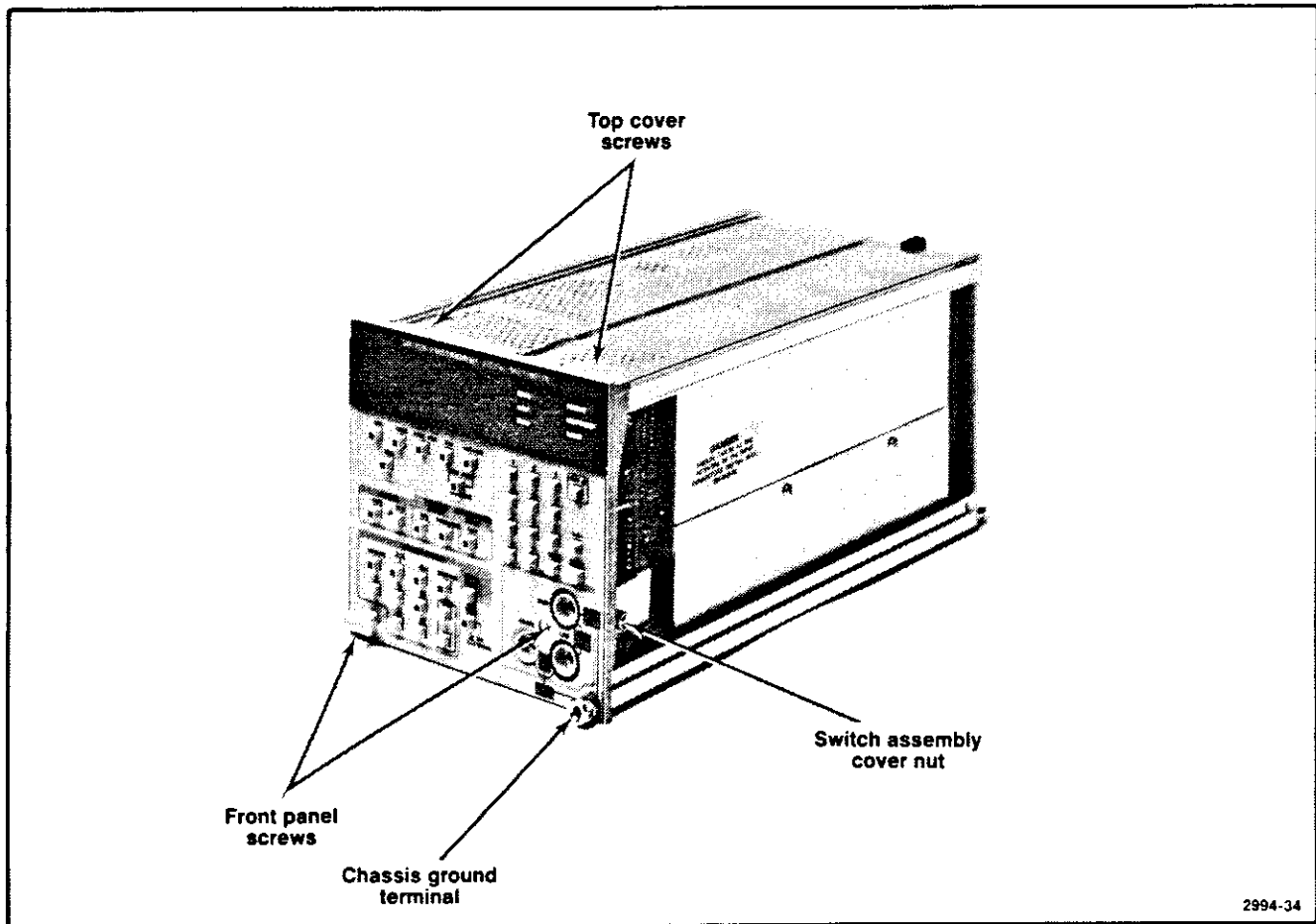

Fig. 7-4. Front panel removal.

Input Switch Assembly

For access to the input switch, remove the ADC board (A17) from the instrument. Then, remove the input connector assembly mounting nut and screw, and remove the guard shield. Refer to Fig. 7-4. Unsolder the wires to the switch. Next, remove the two screws in the back of the input connector assembly and remove the plate. The switch can now be removed. Be careful not to lose the actuator and spring located inside the input connector assembly. Reinstall the guard switch and input connector assembly in reverse order.

Adjusting C1301 and C1404

If the transformer is replaced, the adjustment of C1301 and C1404 should be checked. To accomplish this, place the Isolation board (A15) on an extender board and connect the plug-in to the power module via a flexible extender cable. The recommended equipment is listed below:

| | |
|----------------------|-----------------|
| Oscilloscope | TEKTRONIX 7603 |
| Dual Trace Amplifier | TEKTRONIX 7A18 |
| Time Base | TEKTRONIX 7B50A |

a. Connect the DM 5010 HIGH input connector to the LOW connector. Connect the oscilloscope as shown in Fig. 7-5. Apply power to the power module.

b. ADJUST—C1301 for minimum amplitude of the displayed square wave ($\approx 33 \mu\text{s}$ period). Refer to Fig. 7-6.

c. Add a connection from the DM 5010 GUARD connector to the DM 5010 chassis ground.

d. ADJUST—C1404 for minimum amplitude of the displayed square wave.

e. Remove all connections to the DM 5010 and turn off the power module. Reinstall the Isolation board in the plug-in.

Battery Replacement

The recommended interval for battery replacement is approximately two years.

NOTE

Disconnecting the battery causes the loss of calibration factors stored in memory. Battery replacement must be followed by a 24-hour period of operation and then performance of the Adjustment Procedure.

For access to the battery, unplug the ribbon cable connector from the Front Panel Driver board and remove the CPU board (A14). The battery is located in the rear, bottom corner of the board. Unsolder the battery ears from the wires attached to the circuit board. Use diagonal pliers to cut the two plastic straps holding the battery in position. Place the new battery in the circuit board cutout with correct polarity. Fasten new plastic straps around the battery and through the circuit board holes. Solder the battery ears to the circuit board wires.

Power up the instrument for about 24 hours to properly charge the battery. Then, perform the Adjustment Procedure to restore calibration factors to instrument memory.

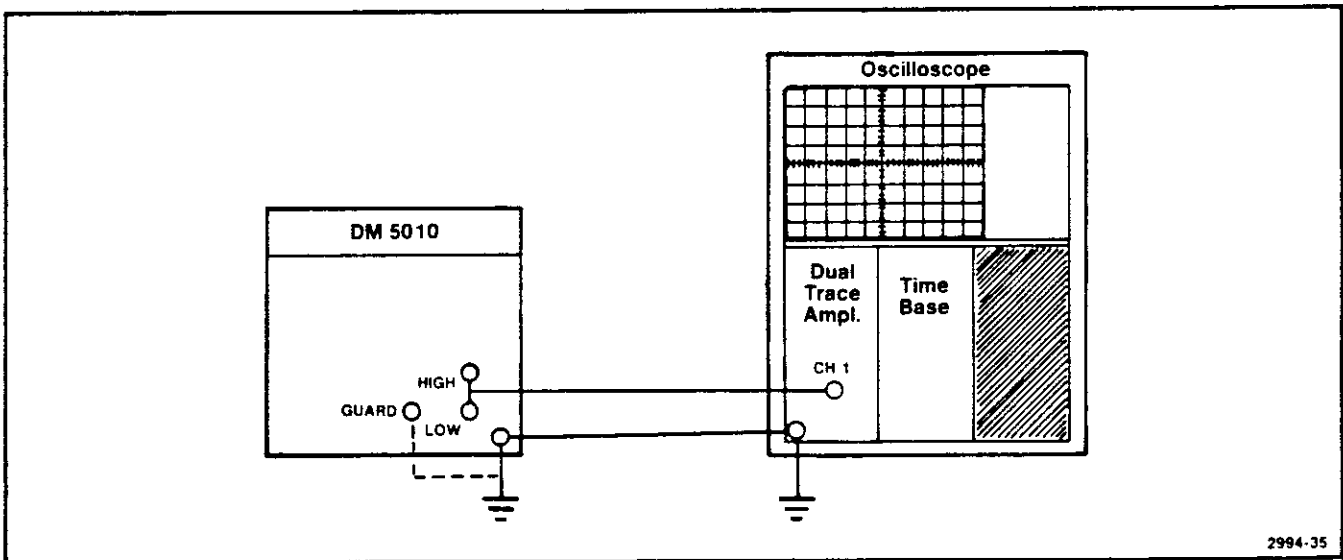

Fig. 7-5. Setup for C1301 and C1404 adjustment.

2994-35

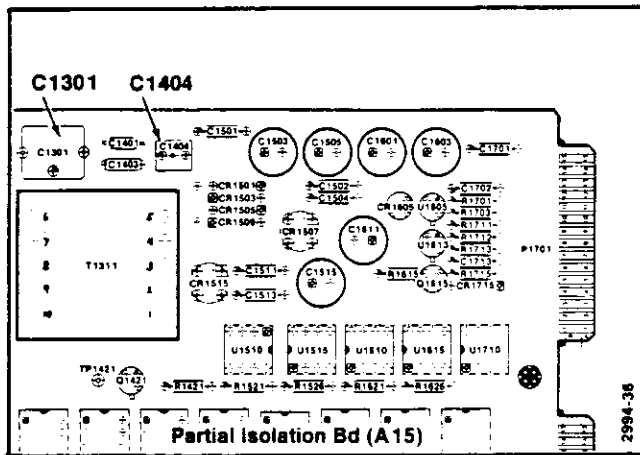

Fig. 7-6. Location of C1301 and C1404.

Troubleshooting Aids

Diagrams. Complete circuit diagrams are located in the foldout pages in the Diagrams and Circuit Board Illustrations section. The portions of the circuit mounted on circuit boards are enclosed by a solid line. The circuit number of each component in this instrument is shown on a diagram. See the first page of the Diagrams and Circuit Board Illustrations section for definitions of the symbols and reference designators used on the diagrams.

Circuit Board Illustrations. Circuit board illustrations are provided in conjunction with circuit diagrams. Each board-mounted component shown on a diagram is also identified on the circuit board illustration by circuit number. A table is provided with each diagram listing components by assembly and circuit number. The table also lists the component grid locations on both the diagram and circuit board illustrations.

Adjustment Locations. To aid in locating test points and adjustable components, the adjustment locations pullout page (normally used with the Adjustment Procedure) permits rapid location of adjustments and associated test points.

Calibration Fixture

Several calibration fixtures are available from Tektronix, Inc. that are helpful in troubleshooting the DM 5010.

067-1052-00—contains two extender boards and a board extractor.

067-0645-02—provides a flexible extender cable.

067-0996-00—contains a GPIB extender cable.

Contact your nearest Tektronix, Inc. Field Office or representative for ordering information.

Troubleshooting Equipment

Before using any test equipment to make measurements on static-sensitive components or assemblies, be certain that any voltage or current supplied by the test equipment does not exceed the limits of the component to be tested.

Static-Sensitive Components

CAUTION

Static discharge can damage any semiconductor component in this instrument.

This instrument contains electrical components that are susceptible to damage from static discharge. See Table 7-2 for relative susceptibility of various classes of semiconductors. Static voltages of 1 kV to 30 kV are common in unprotected environments.

Observe the following precautions to avoid damage.

1. Minimize handling of static-sensitive components.

2. Transport and store static-sensitive components or assemblies in their original containers, on a metal rail, or on conductive foam. Label any package that contains static-sensitive assemblies or components.

3. Discharge the static voltage from your body by wearing a wrist strap while handling these components. Servicing static-sensitive assemblies or components should be performed only at a static-free work station by qualified service personnel.

4. Nothing capable of generating or holding a static charge should be allowed on the work station surface.

5. Keep the component leads shorted together whenever possible.

6. Pick up components by the body, never by the leads.

7. Do not slide the components over any surface.

8. Avoid handling components in areas that have a floor or work surface covering capable of generating a static charge.

9. Use a soldering iron that is connected to earth ground.

10. Use only special anti-static suction type or wick type desoldering tools.

Table 7-2
RELATIVE SUSCEPTIBILITY TO
TO STATIC DISCHARGE DAMAGE

| Semiconductor Classes | Relative Susceptibility Levels ^a |
|---|---|
| MOS or CMOS microcircuits or discretes, or linear microcircuits with MOS inputs. (Most Sensitive) | 1 |
| ECL | 2 |
| Schottky signal diodes | 3 |
| Schottky TTL | 4 |
| High-frequency bipolar transistors | 5 |
| JFETs | 6 |
| Linear microcircuits | 7 |
| Low-power Schottky TTL | 8 |
| TTL (Least Sensitive) | 9 |

^aVoltage equivalent for levels:

1 = 100 to 500 V 4 = 500 V 7 = 400 to 1000 V(est.)
 2 = 200 to 500 V 5 = 400 to 600 V 8 = 900 V
 3 = 250 V 6 = 600 to 800 V 9 = 1200 V

(Voltage discharged from a 100 pF capacitor through a resistance of 100 Ω.)

Obtaining Replacement Parts

Electrical and mechanical parts can be obtained through your local Tektronix Field Office or representative. However, it may be possible to obtain many of the standard electronic components from a local commercial source. Before purchasing or ordering a part from a source other than Tektronix, Inc., check the Replaceable Electrical Parts list for the proper value, rating, tolerance, and description.

NOTE

When selecting replacement parts, remember that the physical size and shape of a component may affect its performance in the instrument.

Some parts are manufactured or selected by Tektronix, Inc., to satisfy particular requirements or are manufactured for Tektronix, Inc., to our specifications. Most of the mechanical parts used in this instrument have been manufactured by Tektronix, Inc. To determine the manufacturer,

refer to the replaceable parts lists and the Cross Reference Index, Mfr. Code Number to Manufacturer.

When ordering replacement parts from Tektronix, Inc., include the following information:

1. Instrument type (include modification or option number);
2. instrument serial number;
3. a description of the part (if electrical, include complete circuit number); and
4. Tektronix part number.

Soldering Techniques



To avoid electric-shock hazard, disconnect the instrument from the power source before soldering.

The reliability and accuracy of this instrument can be maintained only if proper soldering techniques are used when repairing or replacing parts. General soldering techniques, which apply to maintenance of any precision electronic equipment, should be used when working on this instrument. Use only 60/40 rosin-core, electronic grade solder. The choice of soldering iron is determined by the repair to be made.



The CPU, ADC, Front Panel Driver, Front Panel and Isolation boards are multilayer type boards with a conductive path laminated between the top and bottom board layers. All soldering on these boards should be done with extreme care to prevent breaking the connections to this conductive path.

Do not allow solder or solder flux to flow under printed circuit board switches. The printed circuit board is part of the switch contacts; intermittent switch operation can occur if the contacts are contaminated.

When soldering on circuit boards or small wiring, use only a 15 watt, pencil-type soldering iron. A higher wattage soldering iron can cause the etched circuit wiring to sepa-

rate from the board base material and melt the insulation from small wiring. Always keep the soldering iron tip properly tinned to ensure the best heat transfer to the solder joint. Apply only enough heat to remove the component or to make a good solder joint. To protect heat-sensitive components, hold the component lead with a pair of long-nose pliers between the component body and the solder joint. Use a solder removing wick to remove excess solder from connections or to clean circuit board pads.

Semiconductors

To remove in-line integrated circuits mounted in sockets, use an extracting tool. This tool is available from Tektronix, Inc.; order Tektronix Part No. 003-0619-00. If an extracting tool is not available, use care to avoid damaging the pins. Pull slowly and evenly on both ends of the integrated circuit. Try to avoid disengaging one end before the other end.

Exterior Cleaning

Chassis. Accumulated dust on the instrument chassis can be removed with a soft cloth or small brush. Remove dirt that remains with a soft cloth dampened in a mild detergent and water solution; then remove the detergent with a soft cloth dampened in clean water. Do not use abrasive cleaners.

Front Panel. Use only a cotton swab or soft cloth, dampened in isopropyl alcohol or water.



To avoid damage, use only isopropyl alcohol or water. Do not use petroleum based cleaning agents. Before using a cleaner other than isopropyl alcohol, consult your Tektronix Service Center or representative.

Interior Cleaning

Clean circuit boards only when required for operation to specified performance. Cleaning and rinsing solutions can be used on all boards except the Front Panel board. The recommended cleaning and rinse solutions, plus specific cleaning precautions for each board are listed below by board name. Observe this board-specific information and the following general board cleaning information.

General Board Cleaning

1. For boards that can be cleaned with a detergent solution, use only a 20:1 solution of distilled water and Kelite Spray White¹.

¹Allied-Kelite Products Division of the Richardson Co.; Los Angeles, CA.

2. Cleaning after minor repairs to circuit boards can be done by using a soft plastic tool to carefully chip away flux residue. Be careful not to damage circuit board paths and components.

3. Do not immerse boards in cleaning or rinsing solutions; use spray bottles to spray on the specified solutions.



Rinse the area extremely well to completely remove cleaning residue.

4. After cleaning, use dry, low-velocity air (approximately 5 lb/in²) to blow-dry the board (except the Front Panel board).

5. To finish board drying, place in an oven at 40°C to 60°C for a minimum of twenty-four hours.



To prevent damage and to ensure proper operation, circuit boards and components must be dry before applying power.

Board Cleaning

Front-Panel Board (A11). Do not use any type of cleaning or rinsing solutions, water, or compressed air on this board, since cleaning may leave residue and contaminants inside the switch assemblies or on the circuit board contact areas; interfering with both mechanical and electrical operation. If the front-panel switches are intermittent, then replace the switches.

Front-Panel Drive Board (A12). Use the detergent solution specified under General Board Cleaning. Rinse with isopropyl alcohol or warm distilled water.

Main Interconnect Board (A13). Use isopropyl alcohol or the specified detergent solution for cleaning. Rinse very well with warm distilled water or clean isopropyl alcohol.

CPU Board (A14). Use the specified detergent solution or isopropyl alcohol for cleaning. Rinse well with clean isopropyl alcohol or warm distilled water.



To prevent instrument damage and performance degradation, do not allow cleaning or rinsing solutions on the GPIB switches (S1515), or on the battery or battery circuit. Board cleaning around the battery area may be done if the battery is removed first; however, this requires new battery straps for re-installation of the battery and performance of the adjustment procedure to restore calibration constants in memory. To help protect the GPIB switches, apply wide tape to the switch sides and top.

Isolation Board (A15). Use the specified detergent solution for cleaning; rinse well with distilled water.



Do not allow cleaning or rinsing solutions on the transformer. Isopropyl alcohol may be used for cleaning if the transformer is first removed from the board. Rinse very well with generous amounts of clean isopropyl alcohol.

RMS Board (A16). For cleaning, use the specified detergent solution. Rinse with distilled water.



Isopropyl alcohol may be used for cleaning this board if the board is very well rinsed with generous amounts of clean isopropyl alcohol.

ADC Board (A17) and Relay Board (A18). For cleaning, use the specified detergent solution; rinse very well with distilled water. Isopropyl alcohol may be used for cleaning provided the circuit board is very well rinsed with generous amounts of clean isopropyl alcohol.



Do not allow cleaning or rinsing solutions in or on the rear input relay (K1631 on the Relay board), or the guard input switch assembly (S1731).

CPU Board Coating

Some solder connections and board surface areas of the CPU board are coated with a clear, moisture-proof material called Humiseal. These areas are indicated by a gray shading in Fig. 10-6 in the pullout pages (see lower rear area of component side of board). After any soldering on these areas, the shaded solder connections and board surfaces must be recoated to ensure operation to specified performance in a high humidity environment. Clean the worked area by carefully scraping away the damaged portions of the coating. Remove any flux residue; then reapply Humiseal to the indicated surfaces and solder connections, on both sides of the board. Humiseal may be obtained by ordering Tektronix Part No. 006-1744-00.

TROUBLESHOOTING

Introduction

Troubleshooting information for the DM 5010 includes detailed instructions using traditional techniques and signature analysis for selected digital circuit troubleshooting. For troubleshooting purposes, the circuitry in the DM 5010 is broken into circuit sections. Table 7-3 lists typical problem symptoms for these sections. Use these symptoms to help select the malfunctioning circuit; then perform the verification in the table for the selected circuit. Any discrepancy found in verification confirms that the selected section is malfunctioning. If the instrument symptoms suggest malfunctions in several circuit sections, do the verification for the lower numbered section first. Then follow the detailed troubleshooting procedures listed by the circuit section and number following the table. Although the troubleshooting information cannot address every possible fault, it may help isolate the problem area. A review of the Theory of Operation section in this manual should also prove helpful. Refer to board illustrations adjacent to the diagrams in the pullout pages for component and test point locations.

If an error code is either displayed on the instrument front panel or returned to the controller in response to an ERR? query, refer to the error code definitions in the Programming section of this manual. The only error codes that indicate instrument malfunction are those classified as Internal Errors in the error code list. The displayed error code 521 indicates that the Signature Analysis switch is enabled. If CAL is displayed, the internal CAL jumper is set for instrument adjustment. Enabling the signature analysis or adjustment mode affects normal instrument operation.

For access to troubleshooting points on the four rear boards, use the DM 5010 extender boards listed under Troubleshooting Aids in this section of this manual. Also listed are flexible extender cables for operating the DM 5010 outside of the power module.

Signature Analysis

Signature analysis information for troubleshooting some DM 5010 digital circuitry is provided in the pullout pages in the back of this manual. It is probable that, over a period of time, product modifications and updates will become available, or necessary, or both. Due to the impact they have on instrument diagnostics and firmware, some modifications and updates must be installed in a serial manner; that is, all earlier modifications and updates may be a prerequisite to installation of the most recent one requested or suggested.

To determine the applicable signature version for your instrument, compare the board assembly (670-) and firmware (160-) numbers in the DM 5010 Signature Versions Table (in the back of this section) with those on the instrument boards. Use the signature analysis information in the pullout pages for the signature version indicated in the table for your instrument board and firmware configuration.

Signature Table 10A provides signature analysis information for checking the microprocessor, ROM, and address decoding on the CPU board. The DM 5010 setup information for these checks requires positioning the NOP jumper to disable bidirectional buffer U1435 and the buffered data bus. It also enables the NOP buffer, which sends NOP (no

operation) instruction code to the microprocessor. This code causes the microprocessor to sequentially address each memory space in ROM. Signature analysis verifies that the data read from ROM is correct, thus ensuring that the microprocessor, data bus, and ROM are operational. After checking signatures, reset the NOP jumper to the normal operating position. The instrument must be powered down and then back up to reset the microprocessor to normal operation.

Signature Table 10B checks the range shift registers. These tests require setting the DM 5010 Signature Analysis switch to the SA mode. This causes the microprocessor to read and perform a special signature analysis routine. This routine uses a repeatable pattern to set the registers to known states.

WARNING

Dangerous voltages may be encountered in the following troubleshooting procedures. Caution must be exercised. Do not contact the output connectors of the voltage source, or the input connectors or internal circuitry of the DM 5010.

Table 7-3
TYPICAL TROUBLE SYMPTOMS

| Typical Symptoms | Circuit Section—Verification |
|---|---|
| Extinguished or unchanging display. | CPU Board, Diagram 7 1a. POWER SUPPLIES—Check for +5 V dc on P1731-1A or 1B and 2A or 2B (gnd). 1b. CLOCK—Check for 1 MHz squarewave between TP1535 (CK) and TP1531 (gnd). 1c. PON CIRCUIT—Check for TTL logic 1 at U1320-40 (PON). |
| Unchanging or flickering display, or internal error code. | CPU Board, Diagrams 7, 8 2. MICROPROCESSOR—Place NOP jumper P1425 in the enable position. Check for a squarewave on the buffered address lines at U1235 and U1420A; each line should be one-half the frequency of the previous line, going from BA0 to BA11. Check the outputs of U1620 and U1520. Check that the ROM Enables (pin 18 of U1200, U1300, U1305, and U1400) are not locked high or low. With power off, reposition the NOP jumper to connect J1425, pins 1 and 2. Apply power and check that the data lines on both sides of U1435 are not locked high or low. Check that IRQ at U1320-4 is not locked low. Check that VMA and R/W (U1320-5 and 34) are toggling. |

Table 7-3 (cont)

| Typical Symptoms | Circuit Section—Verification | | | | | | | | | | | | | | |
|---|---|----------|------------------------|-----------|------------------------|-----------|------------------------|-----------|------------------------|-----------|------------------------|-----------|------------------------|-----------|---------------------|
| Dead, unchanging, or flickering display, or no response to pushbuttons. | <p>CPU Board, Diagram 9</p> <p>3. FRONT PANEL—Check that U1605-1 (RW3) is a logic 1. With the DIODE TEST button held in, check the same point for a 0.6 ms logic 0 pulse at ≈ 5 ms intervals.</p> | | | | | | | | | | | | | | |
| Error code 311 | <p>Isolation Board, Diagram 4</p> <p>4. ISOLATED SUPPLIES—Using an isolated ground reference, check the following supply voltages:</p> <table data-bbox="646 640 1055 861"> <tr> <td>P1701-7A</td> <td>+35.1 V dc, $\pm 11\%$</td> </tr> <tr> <td>P1701-13B</td> <td>+36.9 V dc, $\pm 11\%$</td> </tr> <tr> <td>P1701-13A</td> <td>-36.9 V dc, $\pm 11\%$</td> </tr> <tr> <td>P1701-14A</td> <td>-17.6 V dc, $\pm 11\%$</td> </tr> <tr> <td>P1701-14B</td> <td>+17.6 V dc, $\pm 11\%$</td> </tr> <tr> <td>P1701-15B</td> <td>-17.6 V dc, $\pm 11\%$</td> </tr> <tr> <td>P1701-15A</td> <td>-27 V dc, $\pm 2\%$</td> </tr> </table> | P1701-7A | +35.1 V dc, $\pm 11\%$ | P1701-13B | +36.9 V dc, $\pm 11\%$ | P1701-13A | -36.9 V dc, $\pm 11\%$ | P1701-14A | -17.6 V dc, $\pm 11\%$ | P1701-14B | +17.6 V dc, $\pm 11\%$ | P1701-15B | -17.6 V dc, $\pm 11\%$ | P1701-15A | -27 V dc, $\pm 2\%$ |
| P1701-7A | +35.1 V dc, $\pm 11\%$ | | | | | | | | | | | | | | |
| P1701-13B | +36.9 V dc, $\pm 11\%$ | | | | | | | | | | | | | | |
| P1701-13A | -36.9 V dc, $\pm 11\%$ | | | | | | | | | | | | | | |
| P1701-14A | -17.6 V dc, $\pm 11\%$ | | | | | | | | | | | | | | |
| P1701-14B | +17.6 V dc, $\pm 11\%$ | | | | | | | | | | | | | | |
| P1701-15B | -17.6 V dc, $\pm 11\%$ | | | | | | | | | | | | | | |
| P1701-15A | -27 V dc, $\pm 2\%$ | | | | | | | | | | | | | | |
| No response to REAR INPUT button, wrong reading, hunts for range, displayed measurement drifts. | <p>Isolation Board, Diagram 5 ADC Board, Diagram 2 RMS Board, Diagram 3</p> <p>5. FUNCTION & RANGE REGISTERS—Repeatedly press the REAR INPUT button and check that the relay clicks with each button press.</p> | | | | | | | | | | | | | | |
| Error code 311, wrong reading, hunts for range. | <p>Isolation Board, Diagrams 4 and 5 ADC Board, Diagram 1</p> <p>6. A/D CONVERTER—Connect U1120-3 on the ADC Board to analog ground. Display reads \approx zero in all DCV ranges.</p> | | | | | | | | | | | | | | |
| One or more DCV readings is out of specification or 311 error code. | <p>Dc Voltage Measuring Circuits, Diagram 1</p> <p>7. Apply 0 V dc and 95% of the full scale dc voltage at the DM 5010 inputs for each DCV range. All readings are within specification.</p> | | | | | | | | | | | | | | |
| One or more ACV or ACV + DCV readings is out of specification. | <p>RMS Board, Diagram 3</p> <p>8. RMS CONVERTER—For both ACV and ACV + DCV, apply a 200 Hz, 5% and 95% of full scale input at the DM 5010 inputs, for the 200 mV through 200 V ranges. Apply a 200 Hz, 14% and 95% of full scale input for the 700 V range. All readings are within specification.</p> | | | | | | | | | | | | | | |
| One or more OHMS readings is out of specification. | <p>RMS Board, Diagram 3</p> <p>9. OHMS CONVERTER—Apply 0 Ω and 95% of the full scale input resistance, at the DM 5010 inputs, for each OHMS range. All readings are within specification.</p> | | | | | | | | | | | | | | |

Table 7-3 (cont)

| Typical Symptoms | Circuit Section—Verification |
|--|--|
| <p>Hangs up bus, or will not communicate over bus with controller.</p> | <p>10. GPIB—Connect a 4051 or 4052 to the DM 5010 power module. Turn all power on. If the message:</p> <p style="text-align: center;">NO SRQ ON UNIT-MESSAGE NUMBER 43</p> <p>is received, type:</p> <p style="text-align: center;">POLL X,Y;16</p> <p>where 16 is the instrument address. Short the DM 5010 inputs. Type the following:</p> <p style="text-align: center;">PRI @16: "DCV 2" INP @16: A\$ PRI A\$</p> <p>The last line on the controller display should be: 0.; or 0.0001; or -0.0001;. The instrument does not have to be within specification to verify bus operation.</p> |

Before beginning troubleshooting on the selected circuit section, visually inspect the circuit board for broken, damaged, or loose components, damaged or shorted circuit paths, etc.

1. POWER SUPPLY, CLOCK, PON CIRCUITS

a. POWER SUPPLY, Isolation Board, Diagram 4

If verification indicated a +5 V malfunction, remove the Isolation board from the DM 5010, but leave the board connected to the flexible extender cable. Check for +5 V at J1733-1A or 1B. If +5 V is present, then a load on either the Main Interconnect board or CPU board is pulling down the +5 V supply.

Check the 3 A fuse on the Isolation board.

Check for +5 V at U1000-2. If not present, check Q1105, Q1104, and PWR (P1031-6B) from the power module.

Check that VR1216 is not shorted.

Check U1000 and Q1101.

Reinstall the Isolation board.

b. CLOCK, CPU Board, Diagram 7

Check U1320-37 for a 1 MHz squarewave.

Check U1320-38 and 39 for a 4 MHz squarewave.

c. PON, CPU Board, Diagram 7

Check VR1232.

Check U1230 (all pins).

2. MICROPROCESSOR, CPU Board, Diagram 7

To troubleshoot this circuit, do the following steps or use a signature analyzer to check the signatures in Table 10A in the pullout pages.

a. On U1320, check that the address and data lines are toggling; \overline{IRQ} , RESET, NMI, and HALT are not stuck low; check for clock pulses on pins 37, 38, 39. Check power and ground to U1320.

b. Check power, ground, data, and address lines in the circuit area including U1235, U1420, U1510, U1520, U1620, U1720, U1730, U1435, U1430, U1425, U1200, U1300, U1305, U1400, U1600, U1505, U1220.

3. FRONT-PANEL, Front-Panel Drive board, Diagram 11

a. If all indicators and push buttons are inoperable, check J1820-12 for +5 V and J1820-20 for +8 V.

b. If one or more LEDs do not illuminate, check the associated anode driver and the circuit path from the anode driver to the front panel.

c. If the same segment in all LEDs stays off or on, check the associated cathode drivers and circuit paths.

d. If only one LED or segment is always off, check that LED and its circuit paths.

e. If one of the push buttons is inoperable, check the push button switch and its circuit board paths.

f. If several push buttons are inoperable, check the column drivers and row lines and their paths between the Front-Panel Drive and Front-Panel boards.

4. ISOLATED SUPPLIES, Isolation Board, Diagram 4

If any of these supplies are working, the problem with a malfunctioning supply is located in the isolated section. When troubleshooting a supply on the Isolation board, use an extender board only for the bottom Isolation board connector to the Main Interconnect board; leave the top connector unconnected.

a. Check the following no load supply voltages on the Isolation board:

Table 7-4
NO LOAD POWER SUPPLY VOLTAGES

| + lead | - lead | Voltage Limits (V dc) |
|-----------|-----------|-----------------------|
| P1701-15B | P1701-15A | +9.2 V to +11.6 V |
| -14B | -4A or 4B | +16.6 V to +20.8 V |
| -14A | -4A or 4B | -20.8 V to -16.6 V |
| -13B | -4A or 4B | +33.3 V to +41.7 V |
| -13A | -4A or 4B | -41.7 V to -33.3 V |
| -7A | -7B | +33.3 V to +41.7 V |

If any of these voltages are outside the limits, check the associated rectifiers and filter capacitors.

b. Check for a 50 V peak-to-peak squarewave (18 μ s up and 18 μ s down) between the collectors (cases) of Q1201 or Q1202 and ground (TP1421). If the squarewave is not present, check the 1/2 A fuse.

c. Check for a 1 MHz TTL squarewave at J1733-11B (B ϕ 2 on diagram 6). If not present, check the circuit back to U1230 on the CPU board.

d. Check for a 27.78 kHz TTL squarewave at U1325B-8 and 9 (on diagram 4). If present, check the transistors and associated components of the transformer drive circuit.

e. Check for a 250 kHz squarewave at U1535B-8 and 9 (diagram 6). If not present, check U1535.

f. Check for a 4 μ s pulse every 72 μ s at U1730-15. If not present, check the -18 circuit (U1635B, U1730, U1635C, U1530B, U1320B).

NOTE

A blown fuse may indicate an overload in another circuit. To troubleshoot an overload condition, it may be helpful to temporarily replace the fuse with a 75 to 200 Ω , 3 W resistor. After troubleshooting, be sure to reinstall the fuse.

5. FUNCTION & RANGE REGISTER

To troubleshoot this circuit, do the following steps or use a signature analyzer to check the signatures in Table 10B in the pullout pages. For the following steps, use an oscilloscope; connect the external trigger (- slope) to U1520-7 on the CPU board, diagram 7. Set the DM 5010 to the fast conversion rate. Set the oscilloscope to 5 V/cm and 2 ms/cm.

a. Check RC at J1731-10B. Look for a closely grouped set of 32 pulses; then check for a second group of 32 pulses, not as closely or as evenly spaced as the first group. Note the position of the last pulse. Then check RD at J1731-9B. It should have a fixed bit pattern only during the second pulse group checked previously. Change the DM 5010 range or function and check that the bit pattern changes. The RD line also has a short pulse just following the last RC pulse. Also check RC and RD on the Main Interconnect board (diagram 10) and at the opto-isolators, U1515-3 and U1610-3 (diagram 5). Change the oscilloscope ground reference to PGND (P1701-4A or 4B, diagram 5), and position the trace near the top of the crt display. Check IRC and IRD at U1515-6 and U1610-6, and on diagram 10 at J1701-11A and 11B.

Next, check the STROBE signal on the ADC and RMS boards at shift registers U1500-1, diagram 2, and U1330-1, diagram 3, respectively. The strobe should appear only during the short pulse at the end of the RD pulse train. Check the input and output (pins 2 and 9) of each register.

If the shift registers are working and a range problem still exists, check the latches and the switches they drive for the malfunction. Refer to Figs. 10-2 and 10-5 in the pullout pages.

6. A/D CONVERTER, Isolation Board, Diagram 5

First determine whether the problem is in the isolated or grounded parts of the A/D Converter. To do this, place the isolation board on one extender, leaving the top board connector unconnected. Jumper U1710-3 (U/D) to U1510-6 (COMP) on the Isolation board. Check the display with U/D jumpered to COMP, an overrange negative voltage indicates the fault is in the isolated circuit; a displayed error code 311 suggests the fault is in the grounded circuit. Remove the jumper between U/D and COMP, and check the indicated circuit.

a. Isolated A/D Circuit: If the problem is in the isolated section, refer to the sections in the DC Voltage Measuring Circuit Troubleshooting section dealing with 311 errors and the Charge-Balancing Converter.

b. Grounded A/D Circuit: Check the path of the TRIG pulse through the control ICs at the following points:

- U1530A-6 (In Progress)
- U1435C-8
- U1425A-5 (M/Z)
- U1435A-3
- U1330A-5 (Override)
- U1230A-5
- U1420C-8
- U1425B-8

Check U1330B-8 (U/D) and U1335B-10 (COMP). COMP should follow U/D.

On diagram 6, check U1635A-12 (EOC) and U1520A-3 (EOAZ). Check Q1 through Q12 of U1525 for a squarewave signal; each signal should be one-half the frequency of the preceding signal.

To check the data generation, trigger the oscilloscope on TP1625. Stop, on diagram 7; then check that U1235-15 and U1320A-6 count out the 17 Advance pulses (diagram 6). Check U1030B-6 (DATA) for a serial representation of the 17 bit input to U1125 and U1030C-8. Check U1125-10 for a

parallel representation of the counters inputs from U1020, U1120, U1220, and U1130. Trigger the oscilloscope on U1425A-5, M/Z, diagram 5; then check that the UP and DOWN pulses beginning at U1020-5 and 4 propagate through the counter ICs and that their outputs toggle appropriately. Check that the counter is reset to 0 by the RS pulse, U1020-11.

7. DC VOLTAGE MEASURING CIRCUITS, ADC Board, Diagrams 1, 2

a. To check the supply voltages to this circuit, place the ADC board on an extender board and measure the voltages listed in Table 7-5.

**Table 7-5
POWER SUPPLY AND REFERENCE VOLTAGES**

| Measurement Location | Diagram | Voltage Limits |
|---|---------|--|
| U1230-16 U1230-6 VR1321-C VR1223-C VR1225-A VR1001-C VR1013-A | 1 | +11.4 V to +12.6 V -12.6 V to -11.4 V +6.28 V to +6.42 V +21.5 V to +22.5 V -22.5 V to -21.5 V +32.5 V to +41.7 V -41.7 V to -32.5 V |
| U1400-14 U1400-7 VR1501-C | 2 | typically -22 V -27.5 V to -26.5 V +4.8 V to +5.4 V |

If the voltages are correct, continue troubleshooting at part 7b.

If these voltages are incorrect, remove the RMS board from the plug-in and remove the ADC board from the extender board. Measure the voltages in Table 7-6, on the extender board connector. The measurement locations are the Main Interconnect board connector pin numbers.

**Table 7-6
NO LOAD POWER SUPPLY VOLTAGES**

| Measurement Location | | Voltage Limits |
|----------------------|----------|--------------------|
| (+ lead) | (- lead) | |
| 15B | 15A | +9.2 V to +11.6 V |
| 14B | 6B | +16.6 V to +20.8 V |
| 14A | 6B | -20.8 V to -16.6 V |
| 13B | 6B | +33.3 V to +41.7 V |
| 13A | 6B | -41.7 V to -33.3 V |

If these voltages are incorrect, refer to the Isolated Supplies troubleshooting information. If they are correct, check the regulation circuit U1601, U1603, U1605, VR1514, CR1611, R1611, and Q1613 on diagram 2 for the proper voltages.

Next, perform one of the troubleshooting parts, based on these symptoms: part b if the display indicates a 311 error code; part c if the displayed measurement is out of specification for the applied dc input voltage.

b. Set the DM 5010 to the power-on settings and check the waveforms in Fig. 7-7 at the locations given. If the waveforms are incorrect, check the components or troubleshooting procedure listed in Table 7-7 for the indicated system.

Table 7-7
ERROR CODE 311 FAULTS

| Symptoms | Component |
|---|---|
| One or more power supplies is incorrect | See part a |
| I M/Z high, I U/D low | U1615 on diagram 5, A/D Converter troubleshooting procedure |
| I M/Z low I U/D high | U1230, C1139 on diagram 1 Q1514, C1514, R1514 on diagram 2 |

c. Check the FET gate waveforms shown in Fig. 7-8 for the indicated FETs with 0 V applied to the DM 5010 input. Set the DM 5010 settings to the power-on states.

If one or more gate waveforms are incorrect, the problem is associated with the FET, the DCV Signal Conditioner bootstrap buffer, or the FET gate drive circuits.

To check the bootstrap buffer, measure the voltage at the junction of the emitters of Q1017 and Q1021 (diagram 1). This voltage should be no more than a few millivolts. If not, troubleshoot the DCV Signal Conditioner, using the procedure provided below.

If the bootstrap buffer is operating correctly, trace the gate signal back through its driver and to the Function and Range Register or the Measurement Enable circuit. Refer to the Function and Range Register, if the problem is in that circuit. Tables 10-2 and 10-5 in the pullout pages show the register output states. If the problem is in the Measurement Enable circuit (no I M/Z at U1400-1, diagram 2), check Q1511, Q1512, and CR1511.

The remainder of this procedure provides troubleshooting information for each of the functional blocks in the isolated section.

Input Switch

Measure the voltage between the input end of R1637 and the isolated grounds (diagram 1).

If the voltage is not equal to the front panel input, check C1723, L1723, K1631, and the solder connections between K1631 and the ADC board.

If the voltage is not equal to the rear interface input, check K1631 and the solder connections between the relay and the ADC board.

If K1631 does not operate, check its drive circuit and the Function and Range Register (U1300-12) output (diagram 2).

Attenuator

Measure the voltage between the junction of R1521 and R1427, and the isolated ground (diagram 1). The junction will be loaded slightly by the test equipment used. Check the components listed in Table 7-8 for the symptoms indicated for the measured voltage. The Function and Range Register states are given in Tables 10-2 and 10-5 in the pullout pages.

Overvoltage Protection and Function Switching

Retain the measurement connections from the previous check, with the DM 5010 set to its power-on state. If the measured voltage is approximately -22 V or +22 V, check Q1327 or Q1323 (diagram 1).

Connect an oscilloscope between the input end of R1222 and the isolated ground. Use the I M/Z (U1230-3) trailing edge as the external trigger; set the oscilloscope for 50 mV/cm and 50 ms/cm. Apply 100 mV to the DM 5010 input. If the displayed waveform is not the same as the waveform in Fig. 7-9, check Q1319 and Q1317.

DCV Signal Conditioner

Connect the oscilloscope between the input end of R1121 and the isolated ground (diagram 1). Use the trailing edge of I M/Z (U1230-3) as the external trigger. Set the oscilloscope for 1 V/cm and 50 ms/cm. Set the DM 5010 to its power-on state. Apply 100 mV, 1 V, and 10 V to the DM 5010 input. For each input, check that the displayed

Table 7-8
ATTENUATOR FAULTS

| Symptom | Diagram | Components |
|--|---------|---|
| Voltage \neq applied input (any range) | 1 | R1637 |
| Voltage \neq applied input in 200 mV through 20 V ranges. Checks good in 200 and 1000 V ranges | 1,2 | R1521, K1527, and its drive circuit, Function and Range Register (U1500-12) output |
| Voltage \neq applied input in 200 or 1000 V ranges. Checks good in 200 mV-20 V ranges | 1,2 | R1429, K1525, and K1425, and their drive circuits, Function and Range Register (U1500-5, 7) outputs |
| Voltage \geq one-half the applied input in 200 mV through 20 V ranges | 1,2 | K1425 and its drive circuit, Function and Range Register (U1500-7) output |
| Voltage $>$ applied input in 200 and 1000 V ranges | 1,2 | K1527 and its drive circuit, Function and Range Register, (U1500-12) output |

waveform matches that shown in Fig. 7-10. If it does not, check U1210, R1101, R1102, Q1105, Q1106, Q1112, Q1114 (diagram 1), and their gate drive circuits (diagram 2); also check the output of the Function and Range Register (U1300-5, 4, 7, 6, on diagram 2). See Tables 10-2 and 10-5 in the pullout pages.

Connect the oscilloscope between U1110-2 and the isolated ground. Set the oscilloscope to 100 mV/cm and apply 100 mV to the DM 5010 input. Check that displayed waveform matches that shown in Fig. 7-10. If it does not, check the components listed in Table 7-9 for the indicated symptoms.

Table 7-9
DCV SIGNAL CONDITIONER FAULTS

| Symptom | Components  |
|---|--|
| U1110-2 at the + or - rail | U1110, U1210, Q1101, Q1111, Q1017, and Q1021 |
| U1110-2 oscillating | C1017, C1019 |
| DM 5010 display is correct but varies at least ± 3 least significant digits | U1210 |

Charge-Balancing Converter

Connect the oscilloscope between the input end of R1229 and the isolated ground. Set the oscilloscope to 1 V/cm and 50 ms/cm and apply 100 mV to the DM 5010 input.

If the displayed waveform does not match that in Fig. 7-10, check R1121, CR1123, CR1125, VR1124, VR1126, and U1120.

Compare the DM 5010 display to the symptoms listed in Table 7-10 and check the indicated components on diagram 1.

Table 7-10
CHARGE-BALANCING CONVERTER FAULTS

| Symptom | Components |
|---|------------------------------------|
| Display indicates 311 error code when a 500 V or greater transient is applied to the DM 5010 input | CR1123, CR1125, VR1124, and VR1126 |
| Display indicates 311 error code when the DM 5010 is in a fixed range and the applied input is more negative than the negative full scale value | CR1129, VR1129 |

8. RMS CONVERTER, RMS Board, Diagram 3

a. To check the first stage of the converter, apply a signal that reflects the problem to the DM 5010 input connectors. Be sure the DM 5010 is set to the ACV or ACV+DCV mode, and to the appropriate range (or autorange). Connect a digital multimeter to TP1701 (low) and TP1503 (high). Check that the nominal ac voltage measured is as listed below for the DM 5010 range:

| DM 5010 Range | Nominal Ac Voltage |
|---------------|-----------------------------|
| 200 mV or 2 V | same as applied input |
| 20 V | 0.1 times the applied input |
| 200 or 700 V | 0.001 times applied input |

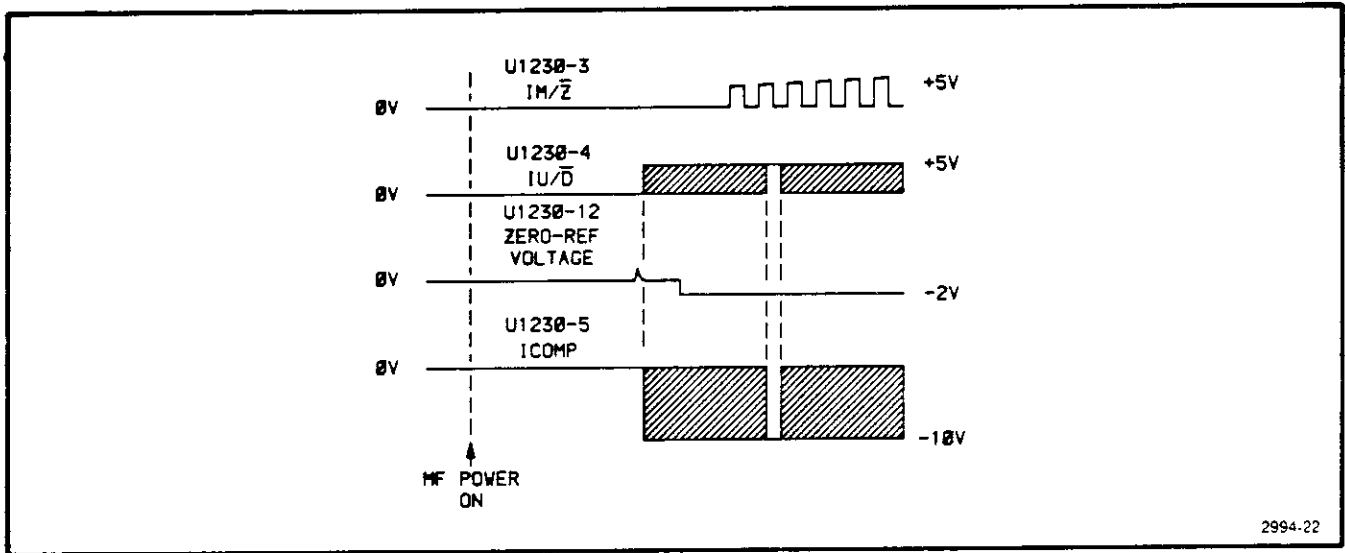

Fig. 7-7. I M/Z, I U/D, ICOMP and the zero-reference voltage waveforms after power on.

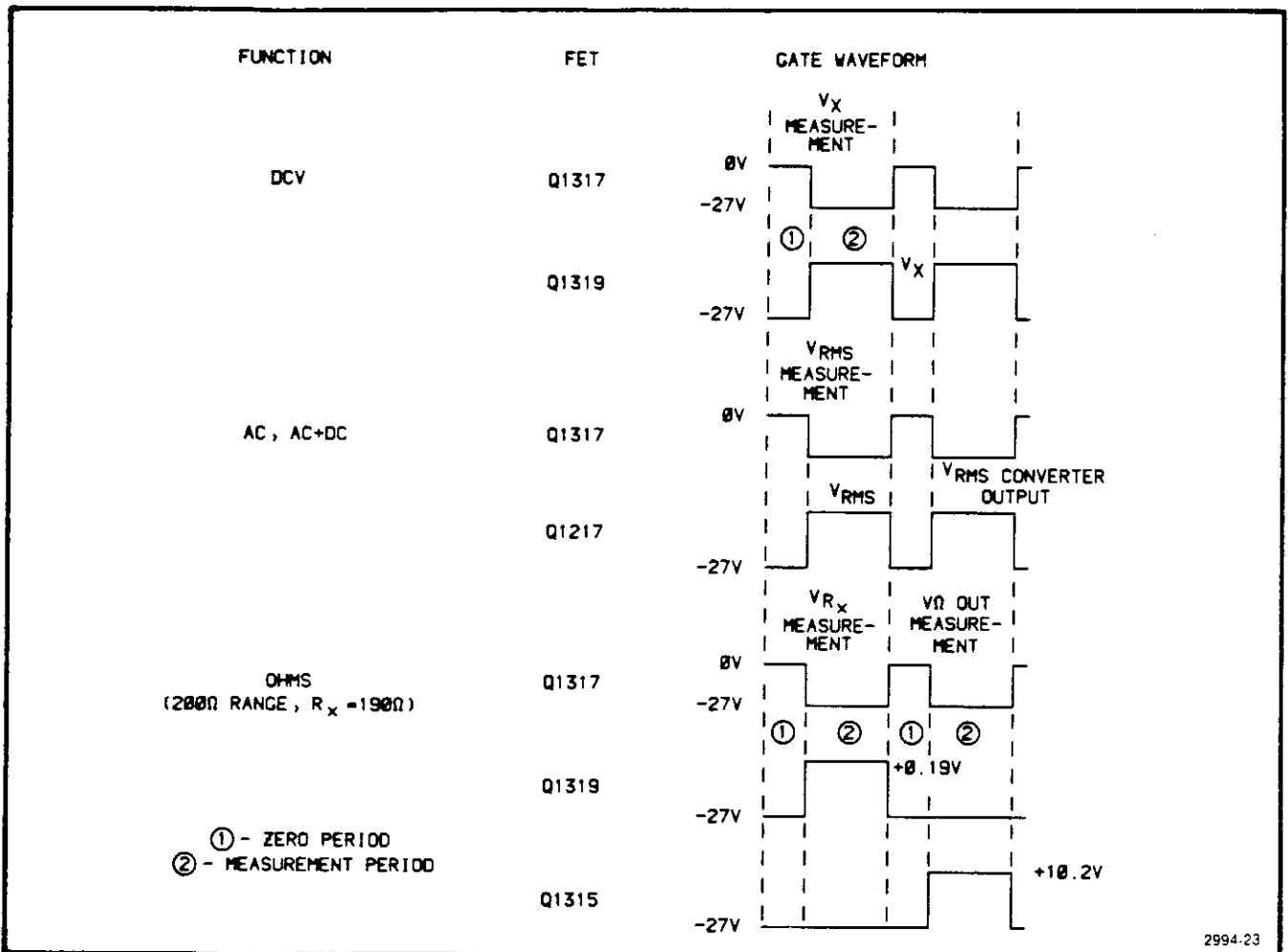

Fig. 7-8. FET Gate timing diagram.

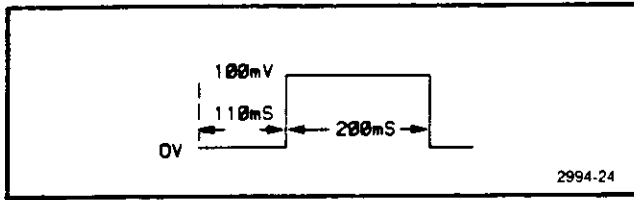

Fig. 7-9. Over-voltage protection and function switching waveform.

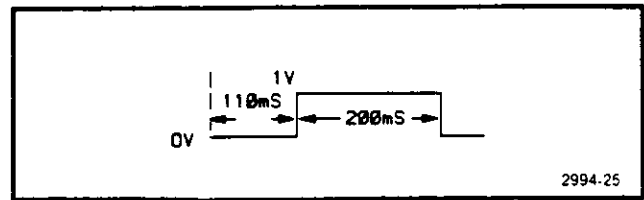

Fig. 7-10. DCV Signal Conditioner and Charge-Balancing Converter waveform.

If the measured voltage is correct, troubleshoot the next stage, according to part 7b. If incorrect, check the components listed in Table 7-11 for the indicated symptoms.

If no error is found, check the final stage of the converter in part 7c. If an error is detected, check the components listed in Table 7-12 for the DM 5010 symptoms.

Table 7-11
RMS CONVERTER FAULTS

| Symptom | Component |
|--|---|
| Error occurs in ACV mode but not in ACV+DCV mode | C1621 |
| Error occurs in ACV+DCV mode with a dc or low frequency ac input | K1621, R1621 |
| Error occurs in all ranges | R1603, R1501, K1621, U1500, C1605, C1607, C1609, C1503, C1505, + and -12 V supplies |
| Error occurs in 200 mV, 2 V ranges | R1501, C1505, C1503 |
| Error occurs in 20 V range | R1403, R1401, C1403, C1504 |
| Error occurs in 200, 700 V ranges | R1309, C1311 |

b. To check the second stage of the RMS Converter, move the digital multimeter high lead to TP1201 (low lead remains at TP1701). Set the applied input voltage to a full scale value for the DM 5010 range being checked. Check that the nominal ac voltage measured is as listed below for the DM 5010 range.

| DM 5010 Range | Nominal Ac Voltage |
|---------------|--------------------|
| 200 mV—200 V | 2 V |
| 700 V | 0.7 V |

Table 7-12
RMS CONVERTER FAULTS

| Symptom | Component |
|---|---|
| Error occurs in all ranges | R1307, R1201, U1200, + and -12 V supplies |
| Error occurs in 200 mV, 200 V ranges | R1201 |
| Error occurs in 2 V, 20 V, 700 V ranges | R1211, K1201 |

c. To check the final converter stage, move the digital multimeter high lead to U1100-8 (low lead remains at TP1701). Check that the measured dc voltage is equal to the rms value of the applied input, scaled to a maximum of 2 V for a full scale input. If an error is detected, check U1100, C1101, C1103, C1001, and R1101. If no error is found, check Q1217 on the ADC board (diagram 1). If Q1217 is good, make sure the A/D Converter is functioning properly by measuring a dc input in the DCV mode. If not, refer to the A/D Converter and Dc Voltage Measuring Circuits troubleshooting information.

9. OHMS CONVERTER, RMS Board, Diagram 3

To troubleshoot the Ohms Converter, place the RMS board on an extender board and set the DM 5010 to the OHMS mode, with the range (in STEP mode) and input condition as listed in Table 7-13. Measure the voltage between the component listed in the table and ohms ground. If the voltage is outside the limits listed, check the designated component.

If the output of U1417-2 is correct, disconnect the RMS board from the extender board and remove the ADC board. On the extender board, measure the voltage between pins 7B and 8B. If the voltage is not between 33.3 and 41.7 V, refer to the Isolated Supplies troubleshooting information. Continue with the measurements in the table.

After making the voltage measurements in Table 7-13, check the components listed below for the indicated symptoms.

Table 7-13
POWER SUPPLY AND REFERENCE VOLTAGES

| Conditions | Measurement Location | Limits | Components |
|-------------------------|----------------------|----------------|--|
| 200 Ω range, 0 Ω input | U1417-2 | 22.8 to 25.2 | See text |
| | U1120-4 | -2.3 to -3.1 | VR1415 |
| | VR1123-C | 8.82 to 9.18 | R1221, VR1123, C1111 |
| | U1120-3 | 0.638 to 0.671 | R1123, R1121, CR1021, CR1121, U1120 |
| | P1711-8A | 9.50 to 10.76 | U1120, CR1227, RT1227, CR1225, R1229, R1321, R1225, R1223, K1313 and its drive circuit, U1330-11 |
| | VR1013-C | 1.8 to 2.6 | R1013, VR1013 |
| 200 Ω range, open input | P1711-4A or 4B | 3.5 to 4.7 | Q1021, CR1011, RT1011, R1331, K1131 and K1231 and their drive circuits, U1300-12, and 14 |
| 2 kΩ range, 0 Ω input | P1711-8A | 1.12 to 1.27 | K1313 and its drive circuit, U1330-11 |
| 20 kΩ range, 0 Ω input | P1711-8A | 9.50 to 10.76 | U1330-11 |
| 200 kΩ range, 0 Ω input | P1711-8A | 1.12 to 1.27 | U1330-11 |
| 2 MΩ range, 0 Ω input | P1711-8A | 1.12 to 1.27 | U1330-11 |
| 20 MΩ range, 0 Ω input | P1711-8A | 1.12 to 1.27 | U1330-11 |

Table 7-14
OHMS CONVERTER FAULTS

| Symptom | Component |
|--|---|
| Display is incorrect in all ranges | Q1315 and its drive circuits (diagram 1) and the output of the Function and Range Register, U1400-11, U1500-6 (diagram 2). For each OHMS range, check the output of the Function and Range Register U1330-11, 12, 13, and 14 (diagram 3). |
| Display indicates 191.90 Ω with a 190.00 Ω input | K1031 and its drive circuit, and the output of the Function and Range Register U1330-13 (diagram 13) |

Nonlinearity in the 20 MΩ range is caused by a lowering of the insulation resistance between High and Low, High and Ω Out, and Low, and chassis ground. Check the components between these signal lines to find the fault.

| Signal | ADC Board 1 | RMS Board 3 |
|--------|-------------|-------------|
| High | P1713-4A | P1711-4A |
| Low | P1713-2A | P1711-2A |
| Ω Out | P1713-8B | P1711-8A |

10. GPIB, CPU Board, Diagram 9

GPIB circuit faults may appear in four places:

- GPIB IC U1105
- Data buffer U1100
- Control buffer U1110
- Circuit board

Visually inspect the circuit board paths and solder connections in the GPIB circuit for damage and poor connections.

Place the CPU board on an extender board plugged into the DM 5010 and apply power via a flexible extender cable to the power module.

a. Check that the data on both sides of data buffer U1100 are the same.

b. Check that the control lines are the same on both sides of control buffer U1110. Check that the lines are in a valid state.

c. To check U1100, remove U1105, using proper static handling procedures; then force U1100-1 (TE) high or low. Force the data buffer inputs (U1100-12 to 19) high and low, checking its outputs (pins 2 to 9). A similar procedure can be used on U1110.

d. If U1100 and U1110 are not faulty, change U1105.

Table 7-15 Signature Versions

| Assembly ROM | 1.0 |
|----------------|-------------|
| A14, CPU | 670-6815-00 |
| U1200 | 160-1329-00 |
| U1300 | 160-1328-00 |
| U1305 | 160-1327-00 |
| U1400 | 160-1326-00 |
| A15, Isolation | 670-6814-00 |
| A16, RMS | 670-6816-00 |
| A17, ADC | 670-6817-00 |

OPTIONS

No options are available.

REPLACEABLE ELECTRICAL PARTS

PARTS ORDERING INFORMATION

Replacement parts are available from or through your local Tektronix, Inc. Field Office or representative.

Changes to Tektronix instruments are sometimes made to accommodate improved components as they become available, and to give you the benefit of the latest circuit improvements developed in our engineering department. It is therefore important, when ordering parts, to include the following information in your order: Part number, instrument type or number, serial number, and modification number if applicable.

If a part you have ordered has been replaced with a new or improved part, your local Tektronix, Inc. Field Office or representative will contact you concerning any change in part number.

Change information, if any, is located at the rear of this manual.

LIST OF ASSEMBLIES

A list of assemblies can be found at the beginning of the Electrical Parts List. The assemblies are listed in numerical order. When the complete component number of a part is known, this list will identify the assembly in which the part is located.

CROSS INDEX-MFR. CODE NUMBER TO MANUFACTURER

The Mfr. Code Number to Manufacturer index for the Electrical Parts List is located immediately after this page. The Cross Index provides codes, names and addresses of manufacturers of components listed in the Electrical Parts List.

ABBREVIATIONS

Abbreviations conform to American National Standard Y1.1.

COMPONENT NUMBER (column one of the Electrical Parts List)

A numbering method has been used to identify assemblies, subassemblies and parts. Examples of this numbering method and typical expansions are illustrated by the following:

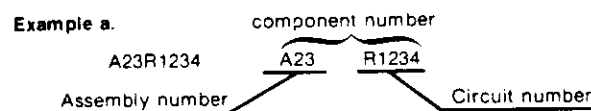

Read: Resistor 1234 of Assembly 23

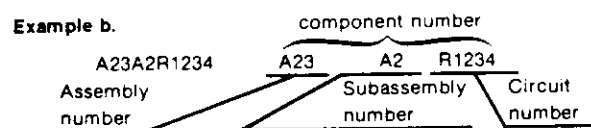

Read: Resistor 1234 of Subassembly 2 of Assembly 23

Only the circuit number will appear on the diagrams and circuit board illustrations. Each diagram and circuit board illustration is clearly marked with the assembly number. Assembly numbers are also marked on the mechanical exploded views located in the Mechanical Parts List. The component number is obtained by adding the assembly number prefix to the circuit number.

The Electrical Parts List is divided and arranged by assemblies in numerical sequence (e.g., assembly A1 with its subassemblies and parts, precedes assembly A2 with its subassemblies and parts).

Chassis-mounted parts have no assembly number prefix and are located at the end of the Electrical Parts List.

TEKTRONIX PART NO. (column two of the Electrical Parts List)

Indicates part number to be used when ordering replacement part from Tektronix.

SERIAL/MODEL NO. (columns three and four of the Electrical Parts List)

Column three (3) indicates the serial number at which the part was first used. Column four (4) indicates the serial number at which the part was removed. No serial number entered indicates part is good for all serial numbers.

NAME & DESCRIPTION (column five of the Electrical Parts List)

In the Parts List, an Item Name is separated from the description by a colon (:). Because of space limitations, an Item Name may sometimes appear as incomplete. For further Item Name identification, the U.S. Federal Cataloging Handbook H6-1 can be utilized where possible.

MFR. CODE (column six of the Electrical Parts List)

Indicates the code number of the actual manufacturer of the part. (Code to name and address cross reference can be found immediately after this page.)

MFR. PART NUMBER (column seven of the Electrical Parts List)

Indicates actual manufacturers part number.

CROSS INDEX - MFR. CODE NUMBER TO MANUFACTURER

| Mfr. Code | Manufacturer | Address | City, State, Zip Code |
|-----------|---|---|---------------------------|
| 00779 | AMP INC | P O BOX 3608 | HARRISBURG PA 17105 |
| 00853 | SANGAMO MESTON INC SANGAMO CAPACITOR DIV | SANGAMO RD P O BOX 128 | PICKENS SC 29671 |
| 01002 | GENERAL ELECTRIC CO CAPACITOR PRODUCTS DEPT | JOHN ST | HUDSON FALLS NY 12839 |
| 01121 | ALLEN-BRADLEY CO | 1201 SOUTH 2ND ST | WILMAUKEE WI 53204 |
| 01295 | TEXAS INSTRUMENTS INC SEMICONDUCTOR GROUP | 13500 N CENTRAL EXPRESSWAY P O BOX 225012 M/S 49 | DALLAS TX 75265 |
| 01963 | CHERRY ELECTRICAL PRODUCTS CORP | 3600 SUNSET AVE | MAUKEGAN IL 60085 |
| 02735 | RCA CORP SOLID STATE DIVISION | ROUTE 202 | SOMERVILLE NJ 08876 |
| 03508 | GENERAL ELECTRIC CO SEMI-CONDUCTOR PRODUCTS DEPT | M GENESEE ST | AUBURN NY 13021 |
| 03888 | KDI PYROFILM CORP | 60 S JEFFERSON RD | MHIPPANY NJ 07981 |
| 04222 | AVX CERAMICS DIV OF AVX CORP | 19TH AVE SOUTH P O BOX 867 | MYRTLE BEACH SC 29577 |
| 04713 | MOTOROLA INC SEMICONDUCTOR GROUP | 5005 E MCDOWELL RD | PHOENIX AZ 85008 |
| 05397 | UNION CARBIDE CORP MATERIALS SYSTEMS DIV | 11901 MADISON AVE | CLEVELAND OH 44101 |
| 05574 | VIKING CONNECTORS INC | 21001 NORDHOFF ST | CHATSWORTH CA 91311 |
| 05828 | GENERAL INSTRUMENT CORP GOVERNMENT SYSTEMS DIV | 600 M JOHN ST | HICKSVILLE NY 11802 |
| 07263 | FAIRCHILD CAMERA AND INSTRUMENT CORP SEMICONDUCTOR DIV | 464 ELLIS ST | MOUNTAIN VIEW CA 94042 |
| 07716 | TRM INC TRM ELECTRONICS COMPONENTS TRM IRC FIXED RESISTORS/BURLINGTON | 2850 MT PLEASANT AVE | BURLINGTON IA 52601 |
| 12969 | UNITRODE CORP | 580 PLEASANT ST | MATERTOWN MA 02172 |
| 14433 | ITT SEMICONDUCTORS DIV | | NEST PALM BEACH FL |
| 14552 | MICRO/SEMICONDUCTOR CORP | 2830 S FAIRVIEW ST | SANTA ANA CA 92704 |
| 14752 | ELECTRO CUBE INC | 1710 S DEL MAR AVE | SAN GABRIEL CA 91776 |
| 15636 | ELEC-TROL INC | 26477 N GOLDEN VALLEY RD | SAUGUS CA 91350 |
| 17856 | SILICONIX INC | 2201 LAURELWOOD RD | SANTA CLARA CA 95054 |
| 18324 | SIGNETICS CORP | 811 E ARQUES | SUNNYVALE CA 94086 |
| 19209 | GENERAL ELECTRIC CO BATTERY BUSINESS DEPT | 441 HWY N P O BOX 861 | GAINESVILLE FL 32602 |
| 19647 | CADDOCK ELECTRONICS INC | 3127 CHICAGO AVE | RIVERSIDE CA 92507 |
| 19701 | MEPCO/ELECTRA INC A NORTH AMERICAN PHILIPS CO | P O BOX 760 | MINERAL WELLS TX 76067 |
| 22526 | DU PONT E I DE MEMOURS AND CO INC DU PONT CONNECTOR SYSTEMS | 30 HUNTER LANE | CAMP HILL PA 17011 |
| 24355 | ANALOG DEVICES INC | RT 1 INDUSTRIAL PK P O BOX 280 | NORMOOD MA 02062 |
| 24546 | CORNING GLASS WORKS | 550 HIGH ST | BRADFORD PA 16701 |
| 27014 | NATIONAL SEMICONDUCTOR CORP | 2900 SEMICONDUCTOR DR | SANTA CLARA CA 95051 |
| 31433 | UNION CARBIDE CORP ELECTRONICS DIV | PO BOX 5928 | GREENVILLE SC 29606 |
| 32997 | BOURNS INC TRIMPOT DIV | 1200 COLUMBIA AVE | RIVERSIDE CA 92507 |
| 33096 | COLORADO CRYSTAL CORP | 2303 M 8TH ST | LOVELAND CO 80537 |
| 34335 | ADVANCED MICRO DEVICES | 901 THOMPSON PL | SUNNYVALE CA 94086 |
| 34371 | HARRIS SEMICONDUCTOR DIV OF HARRIS CORP | P O BOX 883 | MELBOURNE FL 32901 |
| 50157 | MIDWEST COMPONENTS INC | 1981 PORT CITY BLVD P O BOX 787 | MUSKEGON MI 49443 |
| 50434 | HEMLETT-PACKARD CO OPTOELECTRONICS DIV | 640 PAGE MILL RD | PALO ALTO CA 94304 |
| 52763 | STETTNER ELECTRONICS INC | 6135 AIRWAYS BLVD PO BOX 21947 | CHATTANOOGA TN 37421 |
| 52769 | SPRAGUE-GOODMAN ELECTRONICS INC | 134 FULTON AVE | GARDEN CITY PARK NY 11040 |
| 54473 | MATSUSHITA ELECTRIC CORP OF AMERICA | ONE PANASONIC WAY | SECAUCUS NJ 07094 |
| 55680 | NICHICON /AMERICA/ CORP | 927 E STATE PKY | SCHAUMBURG IL 60195 |
| 56289 | SPRAGUE ELECTRIC CO | 87 MARSHALL ST | NORTH ADAMS MA 01247 |
| 57668 | ROHM CORP | 16931 WILLIKEN AVE | IRVINE CA 92713 |
| 58361 | GENERAL INSTRUMENT CORP OPTOELECTRONICS DIV | 3400 HILLVIEW AVE | PALO ALTO CA 94304 |

CROSS INDEX - MFR. CODE NUMBER TO MANUFACTURER

| Mfr. Code | Manufacturer | Address | City, State, Zip Code |
|-----------|--------------------------------------|----------------------|-----------------------------------|
| 59660 | TUSONIX INC | 2155 N FORBES BLVD | TUCSON, ARIZONA 85705 |
| 71400 | MCGRAM-EDISON CO | 502 EARTH CITY PLAZA | ST LOUIS MO 63178 |
| | BUSSMANN MFG DIV | P O BOX 14460 | |
| 74970 | JOHNSON E F CO | 299 10TH AVE S W | MASECA MN 56093 |
| 75042 | TRM INC | 401 N BROAD ST | PHILADELPHIA PA 19108 |
| | TRM ELECTRONIC COMPONENTS | | |
| | IRC FIXED RESISTORS PHILADELPHIA DIV | | |
| 75915 | LITTELFUSE INC | 800 E NORTHWEST HWY | DES PLAINES IL 60016 |
| 80009 | TEKTRONIX INC | 4900 S W GRIFFITH DR | BEAVERTON OR 97077 |
| | | P O BOX 500 | |
| 81073 | GRAYHILL INC | 561 HILLGROVE AVE | LA GRANGE IL 60525 |
| | | P O BOX 373 | |
| 91637 | DALE ELECTRONICS INC | P O BOX 609 | COLUMBUS NE 68601 |
| TK1727 | PHILIPS NEDERLAND BV | POSTBUS 90050 | 5600 PB EINDHOVEN THE NETHERLANDS |
| | AFD ELONCO | | |

Replaceable Electrical Parts - DM 5010

| Component No. | Tektronix Part No. | Serial/Assembly No. Effective Dscont | Name & Description | Mfr. Code | Mfr. Part No. |
|---------------|--------------------|--------------------------------------|---------------------------------------|-----------|----------------|
| A11 | 670-6812-00 | | CIRCUIT 80 ASSY:FRONT PANEL | 80009 | 670-6812-00 |
| A110S1000 | 150-1066-00 | | LAMP,LED RDOOT:ORANGE,6 SEG,+/-1. | 58361 | Q3384/MAN4605A |
| A110S1005 | 150-1053-00 | | LAMP,LED RDOOT:ORANGE, | 58361 | MAN4610A/Q3411 |
| A110S1010 | 150-1043-00 | | LT EMITTING DIO:ORANGE,635NM,35MA MAX | 58361 | MV5774C |
| A110S1015 | 150-1043-00 | | LT EMITTING DIO:ORANGE,635NM,35MA MAX | 58361 | MV5774C |
| A110S1020 | 150-1043-00 | | LT EMITTING DIO:ORANGE,635NM,35MA MAX | 58361 | MV5774C |
| A110S1030 | 150-1043-00 | | LT EMITTING DIO:ORANGE,635NM,35MA MAX | 58361 | MV5774C |
| A110S1032 | 150-1043-00 | | LT EMITTING DIO:ORANGE,635NM,35MA MAX | 58361 | MV5774C |
| A110S1100 | 150-1053-00 | | LAMP,LED RDOOT:ORANGE, | 58361 | MAN4610A/Q3411 |
| A110S1105 | 150-1053-00 | | LAMP,LED RDOOT:ORANGE, | 58361 | MAN4610A/Q3411 |
| A110S1110 | 150-1043-00 | | LT EMITTING DIO:ORANGE,635NM,35MA MAX | 58361 | MV5774C |
| A110S1115 | 150-1043-00 | | LT EMITTING DIO:ORANGE,635NM,35MA MAX | 58361 | MV5774C |
| A110S1120 | 150-1043-00 | | LT EMITTING DIO:ORANGE,635NM,35MA MAX | 58361 | MV5774C |
| A110S1130 | 150-1043-00 | | LT EMITTING DIO:ORANGE,635NM,35MA MAX | 58361 | MV5774C |
| A110S1135 | 150-1043-00 | | LT EMITTING DIO:ORANGE,635NM,35MA MAX | 58361 | MV5774C |
| A110S1200 | 150-1053-00 | | LAMP,LED RDOOT:ORANGE, | 58361 | MAN4610A/Q3411 |
| A110S1210 | 150-1043-00 | | LT EMITTING DIO:ORANGE,635NM,35MA MAX | 58361 | MV5774C |
| A110S1215 | 150-1043-00 | | LT EMITTING DIO:ORANGE,635NM,35MA MAX | 58361 | MV5774C |
| A110S1217 | 150-1043-00 | | LT EMITTING DIO:ORANGE,635NM,35MA MAX | 58361 | MV5774C |
| A110S1220 | 150-1043-00 | | LT EMITTING DIO:ORANGE,635NM,35MA MAX | 58361 | MV5774C |
| A110S1225 | 150-1043-00 | | LT EMITTING DIO:ORANGE,635NM,35MA MAX | 58361 | MV5774C |
| A110S1230 | 150-1043-00 | | LT EMITTING DIO:ORANGE,635NM,35MA MAX | 58361 | MV5774C |
| A110S1237 | 150-1043-00 | | LT EMITTING DIO:ORANGE,635NM,35MA MAX | 58361 | MV5774C |
| A110S1302 | 150-1043-00 | | LT EMITTING DIO:ORANGE,635NM,35MA MAX | 58361 | MV5774C |
| A110S1304 | 150-1043-00 | | LT EMITTING DIO:ORANGE,635NM,35MA MAX | 58361 | MV5774C |
| A110S1306 | 150-1043-00 | | LT EMITTING DIO:ORANGE,635NM,35MA MAX | 58361 | MV5774C |
| A110S1502 | 150-1043-00 | | LT EMITTING DIO:ORANGE,635NM,35MA MAX | 58361 | MV5774C |
| A110S1504 | 150-1043-00 | | LT EMITTING DIO:ORANGE,635NM,35MA MAX | 58361 | MV5774C |
| A110S1506 | 150-1043-00 | | LT EMITTING DIO:ORANGE,635NM,35MA MAX | 58361 | MV5774C |
| A11J1120 | 136-0263-04 | | SOCKET,PIN TERM:U/M 0.025 SQ PIN | 77526 | 75377-001 |
| A11J1300 | 136-0263-04 | | SOCKET,PIN TERM:U/M 0.025 SQ PIN | 22526 | 75377-001 |
| A11J1320 | 136-0263-04 | | SOCKET,PIN TERM:U/M 0.025 SQ PIN | 77526 | 75377-001 |
| A11J1400 | 136-0263-04 | | SOCKET,PIN TERM:U/M 0.025 SQ PIN | 22526 | 75377-001 |
| A11S1010 | 263-0019-35 | | SWITCH PB ASSY:MOMENTARY | 80009 | 263-0019-35 |
| A11S1015 | 263-0019-35 | | SWITCH PB ASSY:MOMENTARY | 80009 | 263-0019-35 |
| A11S1020 | 263-0019-35 | | SWITCH PB ASSY:MOMENTARY | 80009 | 263-0019-35 |
| A11S1025 | 263-0019-38 | | SWITCH PB ASSY:MOMENTARY | 80009 | 263-0019-38 |
| A11S1030 | 263-0019-35 | | SWITCH PB ASSY:MOMENTARY | 80009 | 263-0019-35 |
| A11S1032 | 263-0019-35 | | SWITCH PB ASSY:MOMENTARY | 80009 | 263-0019-35 |
| A11S1035 | 263-0019-38 | | SWITCH PB ASSY:MOMENTARY | 80009 | 263-0019-38 |
| A11S1037 | 263-0019-38 | | SWITCH PB ASSY:MOMENTARY | 80009 | 263-0019-38 |
| A11S1039 | 263-0019-38 | | SWITCH PB ASSY:MOMENTARY | 80009 | 263-0019-38 |
| A11S1110 | 263-0019-35 | | SWITCH PB ASSY:MOMENTARY | 80009 | 263-0019-35 |
| A11S1115 | 263-0019-35 | | SWITCH PB ASSY:MOMENTARY | 80009 | 263-0019-35 |
| A11S1120 | 263-0019-35 | | SWITCH PB ASSY:MOMENTARY | 80009 | 263-0019-35 |
| A11S1130 | 263-0019-35 | | SWITCH PB ASSY:MOMENTARY | 80009 | 263-0019-35 |
| A11S1135 | 263-0019-35 | | SWITCH PB ASSY:MOMENTARY | 80009 | 263-0019-35 |
| A11S1139 | 263-0019-38 | | SWITCH PB ASSY:MOMENTARY | 80009 | 263-0019-38 |
| A11S1210 | 263-0019-35 | | SWITCH PB ASSY:MOMENTARY | 80009 | 263-0019-35 |
| A11S1215 | 263-0019-35 | | SWITCH PB ASSY:MOMENTARY | 80009 | 263-0019-35 |
| A11S1217 | 263-0019-35 | | SWITCH PB ASSY:MOMENTARY | 80009 | 263-0019-35 |
| A11S1220 | 263-0019-35 | | SWITCH PB ASSY:MOMENTARY | 80009 | 263-0019-35 |
| A11S1225 | 263-0019-35 | | SWITCH PB ASSY:MOMENTARY | 80009 | 263-0019-35 |
| A11S1230 | 263-0019-35 | | SWITCH PB ASSY:MOMENTARY | 80009 | 263-0019-35 |
| A11S1232 | 263-0019-38 | | SWITCH PB ASSY:MOMENTARY | 80009 | 263-0019-38 |
| A11S1235 | 263-0019-38 | | SWITCH PB ASSY:MOMENTARY | 80009 | 263-0019-38 |
| A11S1237 | 263-0019-35 | | SWITCH PB ASSY:MOMENTARY | 80009 | 263-0019-35 |
| A11S1239 | 263-0019-38 | | SWITCH PB ASSY:MOMENTARY | 80009 | 263-0019-38 |
| A11S1310 | 263-0019-38 | | SWITCH PB ASSY:MOMENTARY | 80009 | 263-0019-38 |

| Component No. | Tektronix Part No. | Serial/Assembly No. Effective Dscnt | Name & Description | Mfr. Code | Mfr. Part No. |
|---------------|--------------------|-------------------------------------|---------------------------------------|-----------|----------------|
| A11S1315 | 263-0019-38 | | SWITCH PB ASSY:MOMENTARY | 80009 | 263-0019-38 |
| A11S1320 | 263-0019-38 | | SWITCH PB ASSY:MOMENTARY | 80009 | 263-0019-38 |
| A11S1325 | 263-0019-38 | | SWITCH PB ASSY:MOMENTARY | 80009 | 263-0019-38 |
| A11S1410 | 263-0019-38 | | SWITCH PB ASSY:MOMENTARY | 80009 | 263-0019-38 |
| A11S1412 | 263-0019-38 | | SWITCH PB ASSY:MOMENTARY | 80009 | 263-0019-38 |
| A11S1415 | 263-0019-38 | | SWITCH PB ASSY:MOMENTARY | 80009 | 263-0019-38 |
| A11S1417 | 263-0019-38 | | SWITCH PB ASSY:MOMENTARY | 80009 | 263-0019-38 |
| A11S1420 | 263-0019-38 | | SWITCH PB ASSY:MOMENTARY | 80009 | 263-0019-38 |
| A11S1422 | 263-0019-38 | | SWITCH PB ASSY:MOMENTARY | 80009 | 263-0019-38 |
| A11S1425 | 263-0019-38 | | SWITCH PB ASSY:MOMENTARY | 80009 | 263-0019-38 |
| A11S1427 | 263-0019-38 | | SWITCH PB ASSY:MOMENTARY | 80009 | 263-0019-38 |
| A11S1510 | 263-0019-36 | | SWITCH PB ASSY:MOMENTARY | 80009 | 263-0019-36 |
| A11S1520 | 263-0019-38 | | SWITCH PB ASSY:MOMENTARY | 80009 | 263-0019-38 |
| A11S1525 | 263-0019-37 | | SWITCH PB ASSY:MOMENTARY | 80009 | 263-0019-37 |
| A12 | 670-6813-00 | | CIRCUIT BD ASSY:FP DRIVE | 80009 | 670-6813-00 |
| A12C1315 | 281-0775-00 | | CAP,FXD,CER DI:0.1UF,20%,50V | 04222 | MA205E104MAA |
| A12C1431 | 281-0775-00 | | CAP,FXD,CER DI:0.1UF,20%,50V | 04222 | MA205E104MAA |
| A12C1531 | 281-0775-00 | | CAP,FXD,CER DI:0.1UF,20%,50V | 04222 | MA205E104MAA |
| A12C1533 | 281-0775-00 | | CAP,FXD,CER DI:0.1UF,20%,50V | 04222 | MA205E104MAA |
| A12C1741 | 290-0727-00 | | CAP,FXD,ELCTLT:300UF,+75-10%,25V | 56289 | 5000307G025EH7 |
| A12C1821 | 281-0775-00 | | CAP,FXD,CER DI:0.1UF,20%,50V | 04222 | MA205E104MAA |
| A12C1823 | 281-0775-00 | | CAP,FXD,CER DI:0.1UF,20%,50V | 04222 | MA205E104MAA |
| A12J1820 | 131-2514-00 | | CONN,RCPT,ELEC:CKT BD,2 X 10,MALE | 00779 | 86479-1 |
| A12L1731 | 108-0336-00 | | COIL,RF:FIXED,100UH | 80009 | 108-0336-00 |
| A12P1120 | 131-0590-00 | | TERMINAL,PIN:0.71 L X 0.025 SQ PH BRZ | 80009 | 131-0590-00 |
| A12P1300 | 131-0590-00 | | TERMINAL,PIN:0.71 L X 0.025 SQ PH BRZ | 80009 | 131-0590-00 |
| A12P1320 | 131-0590-00 | | TERMINAL,PIN:0.71 L X 0.025 SQ PH BRZ | 80009 | 131-0590-00 |
| A12P1400 | 131-0590-00 | | TERMINAL,PIN:0.71 L X 0.025 SQ PH BRZ | 80009 | 131-0590-00 |
| A12Q1001 | 151-0391-00 | | TRANSISTOR:PNP,SI,X-81 | 04713 | SPS6867K |
| A12Q1005 | 151-0391-00 | | TRANSISTOR:PNP,SI,X-81 | 04713 | SPS6867K |
| A12Q1101 | 151-0391-00 | | TRANSISTOR:PNP,SI,X-81 | 04713 | SPS6867K |
| A12Q1105 | 151-0391-00 | | TRANSISTOR:PNP,SI,X-81 | 04713 | SPS6867K |
| A12Q1201 | 151-0391-00 | | TRANSISTOR:PNP,SI,X-81 | 04713 | SPS6867K |
| A12Q1205 | 151-0391-00 | | TRANSISTOR:PNP,SI,X-81 | 04713 | SPS6867K |
| A12Q1301 | 151-0391-00 | | TRANSISTOR:PNP,SI,X-81 | 04713 | SPS6867K |
| A12Q1305 | 151-0391-00 | | TRANSISTOR:PNP,SI,X-81 | 04713 | SPS6867K |
| A12R1121 | 315-0912-00 | | RES,FXD,FILM:9.1K OHM,5%,0.25M | 57668 | NTR25J-E09K1 |
| A12R1123 | 315-0563-00 | | RES,FXD,FILM:56K OHM,5%,0.25M | 19701 | 5043CX56K00J |
| A12R1125 | 315-0912-00 | | RES,FXD,FILM:9.1K OHM,5%,0.25M | 57668 | NTR25J-E09K1 |
| A12R1127 | 315-0563-00 | | RES,FXD,FILM:56K OHM,5%,0.25M | 19701 | 5043CX56K00J |
| A12R1129 | 315-0912-00 | | RES,FXD,FILM:9.1K OHM,5%,0.25M | 57668 | NTR25J-E09K1 |
| A12R1221 | 315-0563-00 | | RES,FXD,FILM:56K OHM,5%,0.25M | 19701 | 5043CX56K00J |
| A12R1223 | 315-0912-00 | | RES,FXD,FILM:9.1K OHM,5%,0.25M | 57668 | NTR25J-E09K1 |
| A12R1225 | 315-0563-00 | | RES,FXD,FILM:56K OHM,5%,0.25M | 19701 | 5043CX56K00J |
| A12R1227 | 315-0912-00 | | RES,FXD,FILM:9.1K OHM,5%,0.25M | 57668 | NTR25J-E09K1 |
| A12R1229 | 315-0563-00 | | RES,FXD,FILM:56K OHM,5%,0.25M | 19701 | 5043CX56K00J |
| A12R1311 | 315-0563-00 | | RES,FXD,FILM:56K OHM,5%,0.25M | 19701 | 5043CX56K00J |
| A12R1313 | 315-0563-00 | | RES,FXD,FILM:56K OHM,5%,0.25M | 19701 | 5043CX56K00J |
| A12R1315 | 315-0563-00 | | RES,FXD,FILM:56K OHM,5%,0.25M | 19701 | 5043CX56K00J |
| A12R1321 | 315-0912-00 | | RES,FXD,FILM:9.1K OHM,5%,0.25M | 57668 | NTR25J-E09K1 |
| A12R1323 | 315-0912-00 | | RES,FXD,FILM:9.1K OHM,5%,0.25M | 57668 | NTR25J-E09K1 |
| A12R1325 | 315-0912-00 | | RES,FXD,FILM:9.1K OHM,5%,0.25M | 57668 | NTR25J-E09K1 |
| A12R1511 | 315-0151-00 | | RES,FXD,FILM:150 OHM,5%,0.25M | 57668 | NTR25J-E150E |
| A12R1513 | 315-0151-00 | | RES,FXD,FILM:150 OHM,5%,0.25M | 57668 | NTR25J-E150E |
| A12R1515 | 315-0151-00 | | RES,FXD,FILM:150 OHM,5%,0.25M | 57668 | NTR25J-E150E |
| A12R1517 | 315-0151-00 | | RES,FXD,FILM:150 OHM,5%,0.25M | 57668 | NTR25J-E150E |
| A12R1519 | 315-0151-00 | | RES,FXD,FILM:150 OHM,5%,0.25M | 57668 | NTR25J-E150E |
| A12R1611 | 315-0151-00 | | RES,FXD,FILM:150 OHM,5%,0.25M | 57668 | NTR25J-E150E |
| A12R1613 | 315-0151-00 | | RES,FXD,FILM:150 OHM,5%,0.25M | 57668 | NTR25J-E150E |

Replaceable Electrical Parts - DM 5010

| Component No. | Tektronix Part No. | Serial/Assembly No. Effective | Dscont | Name & Description | Mfr. Code | Mfr. Part No. |
|---------------|--------------------|-------------------------------|---------|---|-----------|-----------------|
| A12R1615 | 315-0151-00 | | | RES,FXD,FILM:150 OHM,5%,0.25M | 57668 | NTR25J-E150E |
| A12R1821 | 307-0107-00 | | | RES,FXD,CMPSN:5.6 OHM,5%,0.25M | 01121 | CB5665 |
| A12U1040 | 156-0469-02 | | | MICROCKT,DGTL:3/8 LINE OADR | 01295 | SN74LS138NP3 |
| A12U1130 | 156-0140-02 | | | MICROCKT,DGTL:HEX BUFFERS M/OC HV OUT, | 18324 | N7417(NB OR FB) |
| A12U1230 | 156-0140-02 | | | MICROCKT,DGTL:HEX BUFFERS M/OC HV OUT, | 18324 | N7417(NB OR FB) |
| A12U1330 | 156-0140-02 | | | MICROCKT,DGTL:HEX BUFFERS M/OC HV OUT, | 18324 | N7417(NB OR FB) |
| A12U1420 | 156-1528-00 | | | MICROCKT,DGTL:8IPOLAR,QUARD 2-INP NAND PMR DRVR | 56289 | UHP-408 |
| A12U1520 | 156-1528-00 | | | MICROCKT,DGTL:8IPOLAR,QUARD 2-INP NAND PMR DRVR | 56289 | UHP-408 |
| A12U1720 | 156-0277-00 | | | MICROCKT,LINEAR:VOLTAGE REGULATOR | 04713 | LM340T-5.0 |
| A13 | 670-6818-00 | | | CIRCUIT BD ASSY:MAIN INTERCONNECT | 80009 | 670-6818-00 |
| A13J1701 | 131-1362-01 | | | CONN,RCPT,ELEC:CKT BD,15/30 CONTACT | 80009 | 131-1362-01 |
| A13J1711 | 131-1362-01 | | | CONN,RCPT,ELEC:CKT BD,15/30 CONTACT | 80009 | 131-1362-01 |
| A13J1713 | 131-1362-01 | | | CONN,RCPT,ELEC:CKT BD,15/30 CONTACT | 80009 | 131-1362-01 |
| A13J1731 | 131-2063-00 | | | CONN,RCPT,ELEC:CIRCUIT BOARD,15/30 FEMALE | 05574 | 000-201-4986 |
| A13J1733 | 131-2063-00 | | | CONN,RCPT,ELEC:CIRCUIT BOARD,15/30 FEMALE | 05574 | 000-201-4986 |
| A14 | 670-6815-00 | 8010100 | 8010989 | CIRCUIT BD ASSY:CPU | 80009 | 670-6815-00 |
| A14 | 670-6815-01 | 8010990 | | CIRCUIT BD ASSY:CPU | 80009 | 670-6815-01 |
| A14BT1121 | 146-0037-00 | | | BATTERY,STORAGE:2.4V,0.15AH @ 14MA,(2)1/3 A CELLS,NICAD | 19209 | 418021AC00101 |
| A14C1101 | 281-0775-00 | | | CAP,FXD,CER DI:0.1UF,20%,50V | 04222 | MA205E104MAA |
| A14C1102 | 281-0775-00 | | | CAP,FXD,CER DI:0.1UF,20%,50V | 04222 | MA205E104MAA |
| A14C1133 | 281-0775-00 | | | CAP,FXD,CER DI:0.1UF,20%,50V | 04222 | MA205E104MAA |
| A14C1201 | 281-0775-00 | | | CAP,FXD,CER DI:0.1UF,20%,50V | 04222 | MA205E104MAA |
| A14C1213 | 283-0643-00 | | | CAP,FXD,MICA DI:22PF,0.5%,500V | 00853 | D105E22000 |
| A14C1215 | 283-0643-00 | | | CAP,FXD,MICA DI:22PF,0.5%,500V | 00853 | D105E22000 |
| A14C1223 | 290-0524-00 | 8010100 | 8010989 | CAP,FXD,ELCTLT:4.7UF,20%,10V | 05397 | T368A475M010AZ |
| A14C1223 | 290-0527-00 | 8010990 | | CAP,FXD,ELCTLT:15UF,20%,20V | 05397 | T3688156M020AS |
| A14C1233 | 281-0775-00 | | | CAP,FXD,CER DI:0.1UF,20%,50V | 04222 | MA205E104MAA |
| A14C1235 | 281-0775-00 | | | CAP,FXD,CER DI:0.1UF,20%,50V | 04222 | MA205E104MAA |
| A14C1301 | 281-0775-00 | | | CAP,FXD,CER DI:0.1UF,20%,50V | 04222 | MA205E104MAA |
| A14C1302 | 281-0775-00 | | | CAP,FXD,CER DI:0.1UF,20%,50V | 04222 | MA205E104MAA |
| A14C1321 | 281-0775-00 | | | CAP,FXD,CER DI:0.1UF,20%,50V | 04222 | MA205E104MAA |
| A14C1401 | 281-0775-00 | | | CAP,FXD,CER DI:0.1UF,20%,50V | 04222 | MA205E104MAA |
| A14C1421 | 281-0775-00 | | | CAP,FXD,CER DI:0.1UF,20%,50V | 04222 | MA205E104MAA |
| A14C1426 | 281-0775-00 | | | CAP,FXD,CER DI:0.1UF,20%,50V | 04222 | MA205E104MAA |
| A14C1431 | 281-0775-00 | | | CAP,FXD,CER DI:0.1UF,20%,50V | 04222 | MA205E104MAA |
| A14C1435 | 281-0775-00 | | | CAP,FXD,CER DI:0.1UF,20%,50V | 04222 | MA205E104MAA |
| A14C1501 | 281-0775-00 | | | CAP,FXD,CER DI:0.1UF,20%,50V | 04222 | MA205E104MAA |
| A14C1521 | 281-0775-00 | | | CAP,FXD,CER DI:0.1UF,20%,50V | 04222 | MA205E104MAA |
| A14C1523 | 281-0775-00 | | | CAP,FXD,CER DI:0.1UF,20%,50V | 04222 | MA205E104MAA |
| A14C1601 | 281-0775-00 | | | CAP,FXD,CER DI:0.1UF,20%,50V | 04222 | MA205E104MAA |
| A14C1602 | 281-0775-00 | | | CAP,FXD,CER DI:0.1UF,20%,50V | 04222 | MA205E104MAA |
| A14C1621 | 281-0775-00 | | | CAP,FXD,CER DI:0.1UF,20%,50V | 04222 | MA205E104MAA |
| A14C1631 | 281-0775-00 | | | CAP,FXD,CER DI:0.1UF,20%,50V | 04222 | MA205E104MAA |
| A14C1721 | 281-0775-00 | | | CAP,FXD,CER DI:0.1UF,20%,50V | 04222 | MA205E104MAA |
| A14C1723 | 283-0108-00 | 8010990 | | CAP,FXD,CER DI:220PF,10%,200V | 31433 | C320C221K2G5CA |
| A14C1731 | 283-0177-00 | | | CAP,FXD,CER DI:1UF,+80-20%,25V | 04222 | SR302E105ZAATR |
| A14CR1133 | 152-0245-00 | | | SEMICONO DVC,DI:SM,S1,40V,DO-7 | 03508 | DA2740 |
| A14CR1235 | 152-0245-00 | | | SEMICONO DVC,DI:SM,S1,40V,DO-7 | 03508 | DA2740 |
| A14J1132 | 131-0608-00 | | | TERMINAL,PIN:0.365 L X 0.025 BRZ GLD PL (QTY 3) | 22526 | 48283-036 |
| A14J1425 | 131-0608-00 | | | TERMINAL,PIN:0.365 L X 0.025 BRZ GLD PL (QTY 3) | 22526 | 48283-036 |
| A14J1721 | 131-0608-00 | | | TERMINAL,PIN:0.365 L X 0.025 BRZ GLD PL (QTY 3) | 22526 | 48283-036 |
| A14J1723 | 131-0608-00 | | | TERMINAL,PIN:0.365 L X 0.025 BRZ GLD PL (QTY 3) | 22526 | 48283-036 |

| Component No. | Tektronix Part No. | Serial/Assembly No. Effective | Discont | Name & Description | Mfr. Code | Mfr. Part No. |
|---------------|--------------------|-------------------------------|---------|--|-----------|--------------------|
| A14Q1121 | 151-0190-00 | | | TRANSISTOR:NPN,SI,T0-92 | 80009 | 151-0190-00 |
| A14Q1123 | 151-1103-00 | | | TRANSISTOR:FE,N CHANNEL,SI,T0-72 | 17856 | 0M1001 |
| A14R1101 | 315-0472-00 | | | RES,FXD,FILM:4.7K OHM,5%,0.25M | 57668 | NTR25J-E04K7 |
| A14R1121 | 315-0103-00 | 8010100 | 8010989 | RES,FXD,FILM:10K OHM,5%,0.25M | 19701 | 5043CX10K00J |
| A14R1123 | 315-0103-00 | | | RES,FXD,FILM:10K OHM,5%,0.25M | 19701 | 5043CX10K00J |
| A14R1129 | 315-0103-00 | | | RES,FXD,FILM:10K OHM,5%,0.25M | 19701 | 5043CX10K00J |
| A14R1131 | 315-0101-00 | | | RES,FXD,FILM:100 OHM,5%,0.25M | 57668 | NTR25J-E 100E |
| A14R1132 | 315-0103-00 | | | RES,FXD,FILM:10K OHM,5%,0.25M | 19701 | 5043CX10K00J |
| A14R1133 | 315-0223-00 | | | RES,FXD,FILM:22K OHM,5%,0.25M | 19701 | 5043CX22K00J92U |
| A14R1134 | 315-0223-00 | | | RES,FXD,FILM:22K OHM,5%,0.25M | 19701 | 5043CX22K00J92U |
| A14R1135 | 315-0101-00 | | | RES,FXD,FILM:100 OHM,5%,0.25M | 57668 | NTR25J-E 100E |
| A14R1221 | 315-0222-00 | | | RES,FXD,FILM:2.2K OHM,5%,0.25M | 57668 | NTR25J-E02K2 |
| A14R1223 | 315-0104-00 | | | RES,FXD,FILM:100K OHM,5%,0.25M | 57668 | NTR25J-E100K |
| A14R1225 | 315-0103-00 | | | RES,FXD,FILM:10K OHM,5%,0.25M | 19701 | 5043CX10K00J |
| A14R1227 | 315-0103-00 | 8010100 | 8010989 | RES,FXD,FILM:10K OHM,5%,0.25M | 19701 | 5043CX10K00J |
| A14R1227 | 315-0133-00 | 8010990 | | RES,FXD,FILM:13K OHM,5%,0.25M | 19701 | 5043CX13K00J |
| A14R1231 | 321-0216-00 | | | RES,FXD,FILM:1.74K OHM,1%,0.125M,TC=T0 | 07716 | CEAD17400F |
| A14R1232 | 321-0666-00 | | | RES,FXD,FILM:3.04K OHM,0.5%,0.125M,TC=T2 | 07716 | CEAC304000 |
| A14R1233 | 315-0102-00 | | | RES,FXD,FILM:1K OHM,5%,0.25M | 57668 | NTR25JE01K0 |
| A14R1311 | 315-0393-00 | | | RES,FXD,FILM:39K OHM,5%,0.25M | 57668 | NTR25J-E39K0 |
| A14R1313 | 315-0472-00 | | | RES,FXD,FILM:4.7K OHM,5%,0.25M | 57668 | NTR25J-E04K7 |
| A14R1321 | 315-0472-00 | | | RES,FXD,FILM:4.7K OHM,5%,0.25M | 57668 | NTR25J-E04K7 |
| A14R1611 | 307-0445-00 | | | RES NTWK,FXD,FI:4.7K OHM,20%,(9)RES | 32997 | 4310R-101-472 |
| A14R1621 | 307-0445-00 | | | RES NTWK,FXD,FI:4.7K OHM,20%,(9)RES | 32997 | 4310R-101-472 |
| A14R1623 | 315-0271-00 | 8010990 | | RES,FXD,FILM:270 OHM,5%,0.25M | 57668 | NTR25J-E270E |
| A14S1515 | 260-1721-00 | | | SWITCH,ROCKER:8,SPST,125MA,30VDC | 81073 | 765808S |
| A14TP1531 | 214-0579-00 | | | TERM,TEST POINT:BRS CD PL | 80009 | 214-0579-00 |
| A14TP1533 | 214-0579-00 | | | TERM,TEST POINT:BRS CD PL | 80009 | 214-0579-00 |
| A14TP1535 | 214-0579-00 | | | TERM,TEST POINT:BRS CD PL | 80009 | 214-0579-00 |
| A14TP1621 | 214-0579-00 | | | TERM,TEST POINT:BRS CD PL | 80009 | 214-0579-00 |
| A14TP1625 | 214-0579-00 | | | TERM,TEST POINT:BRS CD PL | 80009 | 214-0579-00 |
| A14U1100 | 156-1414-00 | | | MICROCKT,DGTL:TTL,OCTAL GPIB XCVR DATA BUS | 01295 | SN74LS160 (N OR J) |
| A14U1105 | 156-1444-00 | 8010100 | 8101819 | MICROCKT,DGTL:GPIB ADAPTER | 01295 | TMS9914NL |
| A14U1105 | 156-1441-01 | 8010820 | | MICROCKT,LINER:10 BIT VIDEO SPEED D/A CONV | 80009 | 156-1441-01 |
| A14U1110 | 156-1415-00 | | | MICROCKT,DGTL:TTL,OCTAL GPIB XCVR MGT BUS | 01295 | SN75161A N |
| A14U1200 | 160-1329-00 | | | MICROCKT,DGTL:4096 X 8 EPROM,PROGRAMMED | 80009 | 160-1329-00 |
| A14U1220 | 156-0887-00 | | | MICROCKT,DGTL:CMOS,256 X 4 RAM | 34371 | HM1-6562-9 |
| A14U1230 | 156-1225-00 | | | MICROCKT,LINER:DUAL COMPARATOR | 01295 | LM393P |
| A14U1235 | 156-0956-02 | | | MICROCKT,DGTL:OCTAL BFR M/3 STATE OUT | 01295 | SN74LS244NP3 |
| A14U1300 | 160-1328-00 | | | MICROCKT,DGTL:4096 X 8 EPROM,PROGRAMMED | 80009 | 160-1328-00 |
| A14U1305 | 160-1327-00 | | | MICROCKT,DGTL:4096 X 8 EPROM,PROGRAMMED | 80009 | 160-1327-00 |
| A14U1320 | 156-1342-00 | | | MICROCKT,DGTL:NMOS,8 BIT M/CLOCK & RAM | 04713 | MC6802P |
| A14U1400 | 160-1326-00 | | | MICROCKT,DGTL:4096 X 8 EPROM,PROGRAMMED | 80009 | 160-1326-00 |
| A14U1420 | 156-0956-02 | | | MICROCKT,DGTL:OCTAL BFR M/3 STATE OUT | 01295 | SN74LS244NP3 |
| A14U1425 | 156-0385-02 | | | MICROCKT,DGTL:HEX INVERTER | 07263 | 74LS04PCQR |
| A14U1430 | 156-0914-02 | | | MICROCKT,DGTL:OCT ST BFR M/3 STATE OUT | 01295 | SN74LS240NP3 |
| A14U1435 | 156-1111-02 | | | MICROCKT,DGTL:OCTAL BUS TRANSCEIVERS | 01295 | SN74LS245N3 |
| A14U1505 | 156-1127-01 | | | MICROCKT,DGTL:1024 X 4 STATIC RAM | 80009 | 156-1127-01 |
| A14U1510 | 156-0541-02 | | | MICROCKT,DGTL:DUAL 2-TO 4-LINE DCOR/DEMUX | 04713 | SN74LS139N05 |
| A14U1520 | 156-0469-02 | | | MICROCKT,DGTL:3/8 LINE DCOR | 01295 | SN74LS138NP3 |
| A14U1600 | 156-1127-01 | | | MICROCKT,DGTL:1024 X 4 STATIC RAM | 80009 | 156-1127-01 |
| A14U1605 | 156-1535-00 | | | MICROCKT,DGTL:NMOS,PROGRAMMABLE KYBD/DLY IN TERFACE, | 34335 | AM8279-5(N OR J) |
| A14U1610 | 156-0914-02 | | | MICROCKT,DGTL:OCT ST BFR M/3 STATE OUT | 01295 | SN74LS240NP3 |
| A14U1620 | 156-0469-02 | | | MICROCKT,DGTL:3/8 LINE DCOR | 01295 | SN74LS138NP3 |
| A14U1630 | 156-0386-02 | | | MICROCKT,DGTL:TRIPLE 3-INP NAND GATE | 07263 | 74LS10PCQR |
| A14U1720 | 156-0804-02 | | | MICROCKT,DGTL:QUADRUPLE S-R LATCH | 01295 | SN74LS279NP3/JP4 |
| A14U1730 | 156-0724-02 | | | MICROCKT,DGTL:HEX INV M/OC OUT,SCRN, | 01295 | SN74LS05NP3 |
| A14VR1232 | 152-0667-00 | | | SEMICON DVC,DI:ZEN,SI,3.0 V # 2% AT 2MA | 04713 | 5IG30025RL |

Replaceable Electrical Parts - DM 5010

| Component No. | Tektronix Part No. | Serial/Assembly No. Effective | Dscont | Name & Description | Mfr. Code | Mfr. Part No. |
|---------------|--------------------|-------------------------------|---------|--|-----------|-----------------|
| A14Y1221 | 158-0251-00 | | | XTAL UNIT,QTZ:4.0MHZ,0.001%,ANTIRESONANT | 33096 | PG 1370 |
| A15 | 670-6814-00 | 8010100 | 8021245 | CIRCUIT BD ASSY:ISOLATION | 80009 | 670-6814-00 |
| A15 | 670-6814-01 | 8021245 | 8021349 | CIRCUIT BD ASSY:ISOLATION | 80009 | 670-6814-01 |
| A15 | 670-6814-02 | 8021350 | | CIRCUIT BD ASSY:ISOLATION | 80009 | 670-6814-02 |
| A15C1001 | 281-0775-00 | | | CAP,FXD,CER DI:0.1UF,20%,50V | 04222 | MA205E104MAA |
| A15C1005 | 283-0198-00 | | | CAP,FXD,CER DI:0.22UF,20%,50V | 05397 | C330C224M5U1CA |
| A15C1021 | 281-0775-00 | | | CAP,FXD,CER DI:0.1UF,20%,50V | 04222 | MA205E104MAA |
| A15C1101 | 281-0775-00 | | | CAP,FXD,CER DI:0.1UF,20%,50V | 04222 | MA205E104MAA |
| A15C1107 | 281-0775-00 | | | CAP,FXD,CER DI:0.1UF,20%,50V | 04222 | MA205E104MAA |
| A15C1111 | 283-0212-00 | | | CAP,FXD,CER DI:2UF,20%,50V | 04222 | SR405E205MAA |
| A15C1113 | 290-0755-00 | | | CAP,FXD,ELCTLT:100UF,+50%-10%,10V | 54473 | ECE-A10V100L |
| A15C1121 | 281-0775-00 | | | CAP,FXD,CER DI:0.1UF,20%,50V | 04222 | MA205E104MAA |
| A15C1131 | 281-0775-00 | | | CAP,FXD,CER DI:0.1UF,20%,50V | 04222 | MA205E104MAA |
| A15C1201 | 283-0100-00 | | | CAP,FXD,CER DI:0.0047UF,10%,200V | 04222 | SR306A472KAA |
| A15C1203 | 283-0212-00 | | | CAP,FXD,CER DI:2UF,20%,50V | 04222 | SR405E205MAA |
| A15C1215 | 281-0775-00 | 8010100 | 8010369 | CAP,FXD,CER DI:0.1UF,20%,50V | 04222 | MA205E104MAA |
| A15C1215 | 281-0813-00 | 8010370 | | CAP,FXD,CER DI:0.047UF,20%,50V | 05397 | C412C473M5V2CA |
| A15C1216 | 281-0775-00 | 8010100 | 8010369 | CAP,FXD,CER DI:0.1UF,20%,50V | 04222 | MA205E104MAA |
| A15C1216 | 281-0813-00 | 8010370 | | CAP,FXD,CER DI:0.047UF,20%,50V | 05397 | C412C473M5V2CA |
| A15C1221 | 290-0114-00 | | | CAP,FXD,ELCTLT:47UF,20%,6V | 05397 | T110B476M006AS |
| A15C1223 | 281-0775-00 | | | CAP,FXD,CER DI:0.1UF,20%,50V | 04222 | MA205E104MAA |
| A15C1301 | 281-0116-00 | | | CAP,VAR,AIR DI:1.5-9.1PF,530V | 74970 | 189-0754-075 |
| A15C1321 | 281-0775-00 | | | CAP,FXD,CER DI:0.1UF,20%,50V | 04222 | MA205E104MAA |
| A15C1326 | 281-0775-00 | | | CAP,FXD,CER DI:0.1UF,20%,50V | 04222 | MA205E104MAA |
| A15C1331 | 281-0775-00 | | | CAP,FXD,CER DI:0.1UF,20%,50V | 04222 | MA205E104MAA |
| A15C1401 | 283-0434-00 | 8010100 | 8010499 | CAP,FXD,CER DI:26.5PF,2%,1000V | 59660 | 808000C0G02659F |
| A15C1401 | 283-0109-00 | 8010500 | | CAP,FXD,CER DI:27PF,5%,1000V | 59660 | 858-534C0G0270J |
| A15C1403 | 283-0199-00 | | | CAP,FXD,CER DI:25PF,10%,4000V | 59660 | 0818617C0G0250K |
| A15C1404 | 281-0184-00 | | | CAP,VAR,PLASTIC:2-18PF,500VDC | TK1727 | 2222-809-05003 |
| A15C1421 | 281-0775-00 | | | CAP,FXD,CER DI:0.1UF,20%,50V | 04222 | MA205E104MAA |
| A15C1426 | 281-0775-00 | | | CAP,FXD,CER DI:0.1UF,20%,50V | 04222 | MA205E104MAA |
| A15C1501 | 281-0775-00 | | | CAP,FXD,CER DI:0.1UF,20%,50V | 04222 | MA205E104MAA |
| A15C1502 | 281-0775-00 | | | CAP,FXD,CER DI:0.1UF,20%,50V | 04222 | MA205E104MAA |
| A15C1503 | 290-0768-00 | | | CAP,FXD,ELCTLT:10UF,+50-10%,100VDC | 54473 | ECE-A100V10L |
| A15C1504 | 281-0775-00 | | | CAP,FXD,CER DI:0.1UF,20%,50V | 04222 | MA205E104MAA |
| A15C1505 | 290-0950-00 | | | CAP,FXD,ELCTLT:100UF,+50-10%,50V | 55680 | ULB1H101TJAANA |
| A15C1511 | 281-0775-00 | | | CAP,FXD,CER DI:0.1UF,20%,50V | 04222 | MA205E104MAA |
| A15C1513 | 281-0775-00 | | | CAP,FXD,CER DI:0.1UF,20%,50V | 04222 | MA205E104MAA |
| A15C1515 | 290-0768-00 | | | CAP,FXD,ELCTLT:10UF,+50-10%,100VDC | 54473 | ECE-A100V10L |
| A15C1521 | 281-0775-00 | | | CAP,FXD,CER DI:0.1UF,20%,50V | 04222 | MA205E104MAA |
| A15C1526 | 281-0775-00 | | | CAP,FXD,CER DI:0.1UF,20%,50V | 04222 | MA205E104MAA |
| A15C1601 | 290-0950-00 | | | CAP,FXD,ELCTLT:100UF,+50-10%,50V | 55680 | ULB1H101TJAANA |
| A15C1603 | 290-0745-00 | | | CAP,FXD,ELCTLT:22UF,+50-10%,25V | 54473 | ECE-A25V22L |
| A15C1611 | 290-0768-00 | | | CAP,FXD,ELCTLT:10UF,+50-10%,100VDC | 54473 | ECE-A100V10L |
| A15C1621 | 281-0775-00 | | | CAP,FXD,CER DI:0.1UF,20%,50V | 04222 | MA205E104MAA |
| A15C1626 | 281-0775-00 | | | CAP,FXD,CER DI:0.1UF,20%,50V | 04222 | MA205E104MAA |
| A15C1701 | 281-0775-00 | | | CAP,FXD,CER DI:0.1UF,20%,50V | 04222 | MA205E104MAA |
| A15C1702 | 281-0775-00 | | | CAP,FXD,CER DI:0.1UF,20%,50V | 04222 | MA205E104MAA |
| A15C1713 | 281-0775-00 | | | CAP,FXD,CER DI:0.1UF,20%,50V | 04222 | MA205E104MAA |
| A15C1721 | 281-0775-00 | | | CAP,FXD,CER DI:0.1UF,20%,50V | 04222 | MA205E104MAA |
| A15C1731 | 283-0177-00 | | | CAP,FXD,CER DI:1UF,+80-20%,25V | 04222 | SR302E105ZAATR |
| A15CR1201 | 152-0574-00 | | | SEMICOND DVC,DI:5M,S1,120V,0.15A,00-35 | 12969 | N0P566 |
| A15CR1203 | 152-0574-00 | | | SEMICOND DVC,DI:5M,S1,120V,0.15A,00-35 | 12969 | N0P566 |
| A15CR1211 | 152-0574-00 | | | SEMICOND DVC,DI:5M,S1,120V,0.15A,00-35 | 12969 | N0P566 |
| A15CR1212 | 152-0574-00 | | | SEMICOND DVC,DI:5M,S1,120V,0.15A,00-35 | 12969 | N0P566 |
| A15CR1501 | 152-0574-00 | | | SEMICOND DVC,DI:5M,S1,120V,0.15A,00-35 | 12969 | N0P566 |
| A15CR1503 | 152-0574-00 | | | SEMICOND DVC,DI:5M,S1,120V,0.15A,00-35 | 12969 | N0P566 |
| A15CR1505 | 152-0574-00 | | | SEMICOND DVC,DI:5M,S1,120V,0.15A,00-35 | 12969 | N0P566 |
| A15CR1507 | 152-0779-00 | | | SEMICOND DVC,DI:RECT,S1,200V,0.75A | 05828 | RMO2M |

| Component No. | Tektronix Part No. | Serial/Assembly No. Effective Dscont | Name & Description | Mfr. Code | Mfr. Part No. |
|---------------|--------------------|--------------------------------------|---|-----------|-----------------|
| A15CR1509 | 152-0574-00 | | SEMICOND DVC,DI:SM,SI,120V,0.15A,00-35 | 12969 | NDP566 |
| A15CR1515 | 152-0779-00 | | SEMICOND DVC,DI:RECT,SI,200V,0.75A | 05828 | RM02M |
| A15CR1605 | 152-0307-00 | | SEMICOND DVC,DI:SM,SI,100V,0.13A,00-92 | 04713 | SS01150 |
| A15CR1715 | 152-0141-02 | | SEMICOND DVC,DI:SM,SI,30V,150MA,30V | 03508 | 0A2527 (1N4152) |
| A15F1111 | 159-0015-00 | | FUSE,CARTRIDGE:3AG,3A,250V,0.65SEC | 75915 | 312 003 |
| A15F1113 | 159-0025-00 | | FUSE,CARTRIDGE:3AG,0.5A,250V,0.25SEC | 71400 | AGC-CM-1/2 |
| A15L1201 | 108-0200-00 | | COIL,RF:FIXED,52UH | 80009 | 108-0200-00 |
| A15L1203 | 108-0200-00 | | COIL,RF:FIXED,52UH | 80009 | 108-0200-00 |
| A15Q1101 | 151-0301-00 | | TRANSISTOR:PNP,SI,TO-18 | 04713 | ST898 |
| A15Q1104 | 151-0188-00 | | TRANSISTOR:PNP,SI,TO-92 | 80009 | 151-0188-00 |
| A15Q1105 | 151-0190-00 | | TRANSISTOR:NPN,SI,TO-92 | 80009 | 151-0190-00 |
| A15Q1201 | 151-0200-00 | | TRANSISTOR:NPN,SI,TO-5 | 04713 | 2N3499 |
| A15Q1202 | 151-0200-00 | | TRANSISTOR:NPN,SI,TO-5 | 04713 | 2N3499 |
| A15Q1211 | 151-0190-00 | | TRANSISTOR:NPN,SI,TO-92 | 80009 | 151-0190-00 |
| A15Q1212 | 151-0190-00 | | TRANSISTOR:NPN,SI,TO-92 | 80009 | 151-0190-00 |
| A15Q1213 | 151-0188-00 | | TRANSISTOR:PNP,SI,TO-92 | 80009 | 151-0188-00 |
| A15Q1214 | 151-0188-00 | | TRANSISTOR:PNP,SI,TO-92 | 80009 | 151-0188-00 |
| A15Q1421 | 151-0190-00 | | TRANSISTOR:NPN,SI,TO-92 | 80009 | 151-0190-00 |
| A15Q1615 | 151-0301-00 | | TRANSISTOR:PNP,SI,TO-18 | 04713 | ST898 |
| A15R1001 | 315-0431-00 | | RES,FXD,FILM:430 OHM,5%,0.25M | 19701 | 5043CX430R0J |
| A15R1003 | 315-0333-00 | | RES,FXD,FILM:33K OHM,5%,0.25M | 57668 | NTR25J-E33K0 |
| A15R1005 | 315-0102-00 | | RES,FXD,FILM:1K OHM,5%,0.25M | 57668 | NTR25JE01K0 |
| A15R1101 | 315-0201-00 | | RES,FXD,FILM:200 OHM,5%,0.25M | 57668 | NTR25J-E200E |
| A15R1102 | 315-0821-00 | | RES,FXD,FILM:820 OHM,5%,0.25M | 19701 | 5043CX820R0J |
| A15R1103 | 315-0123-00 | | RES,FXD,FILM:12K OHM,5%,0.25M | 57668 | NTR25J-E12K0 |
| A15R1104 | 315-0562-00 | | RES,FXD,FILM:5.6K OHM,5%,0.25M | 57668 | NTR25J-E05K6 |
| A15R1105 | 315-0333-00 | | RES,FXD,FILM:33K OHM,5%,0.25M | 57668 | NTR25J-E33K0 |
| A15R1106 | 317-0047-00 | | RES,FXD,CMPSN:4.7 OHM,5%,0.125M | 01121 | 8B47G5 |
| A15R1107 | 315-0391-00 | | RES,FXD,FILM:390 OHM,5%,0.25M | 57668 | NTR25J-E390E |
| A15R1108 | 315-0123-00 | | RES,FXD,FILM:12K OHM,5%,0.25M | 57668 | NTR25J-E12K0 |
| A15R1109 | 315-0123-00 | | RES,FXD,FILM:12K OHM,5%,0.25M | 57668 | NTR25J-E12K0 |
| A15R1201 | 315-0910-00 | | RES,FXD,FILM:91 OHM,5%,0.25M | 19701 | 5043CX91R00J |
| A15R1211 | 315-0102-00 | | RES,FXD,FILM:1K OHM,5%,0.25M | 57668 | NTR25JE01K0 |
| A15R1212 | 315-0102-00 | | RES,FXD,FILM:1K OHM,5%,0.25M | 57668 | NTR25JE01K0 |
| A15R1213 | 315-0751-00 | | RES,FXD,FILM:750 OHM,5%,0.25M | 57668 | NTR25J-E750E |
| A15R1214 | 315-0751-00 | | RES,FXD,FILM:750 OHM,5%,0.25M | 57668 | NTR25J-E750E |
| A15R1215 | 315-0271-00 | | RES,FXD,FILM:270 OHM,5%,0.25M | 57668 | NTR25J-E270E |
| A15R1216 | 315-0271-00 | | RES,FXD,FILM:270 OHM,5%,0.25M | 57668 | NTR25J-E270E |
| A15R1217 | 315-0122-00 | | RES,FXD,FILM:1.2K OHM,5%,0.25M | 57668 | NTR25J-E01K2 |
| A15R1421 | 315-0122-00 | | RES,FXD,FILM:1.2K OHM,5%,0.25M | 57668 | NTR25J-E01K2 |
| A15R1521 | 315-0271-00 | | RES,FXD,FILM:270 OHM,5%,0.25M | 57668 | NTR25J-E270E |
| A15R1526 | 315-0271-00 | | RES,FXD,FILM:270 OHM,5%,0.25M | 57668 | NTR25J-E270E |
| A15R1531 | 315-0102-00 | | RES,FXD,FILM:1K OHM,5%,0.25M | 57668 | NTR25JE01K0 |
| A15R1615 | 315-0242-00 | | RES,FXD,FILM:2.4K OHM,5%,0.25M | 57668 | NTR25J-E02K4 |
| A15R1621 | 315-0271-00 | | RES,FXD,FILM:270 OHM,5%,0.25M | 57668 | NTR25J-E270E |
| A15R1626 | 315-0271-00 | | RES,FXD,FILM:270 OHM,5%,0.25M | 57668 | NTR25J-E270E |
| A15R1701 | 315-0102-00 | | RES,FXD,FILM:1K OHM,5%,0.25M | 57668 | NTR25JE01K0 |
| A15R1703 | 315-0562-00 | | RES,FXD,FILM:5.6K OHM,5%,0.25M | 57668 | NTR25J-E05K6 |
| A15R1711 | 315-0562-00 | | RES,FXD,FILM:5.6K OHM,5%,0.25M | 57668 | NTR25J-E05K6 |
| A15R1712 | 315-0750-00 | | RES,FXD,FILM:75 OHM,5%,0.25M | 57668 | NTR25J-E75E0 |
| A15R1713 | 315-0102-00 | | RES,FXD,FILM:1K OHM,5%,0.25M | 57668 | NTR25JE01K0 |
| A15R1715 | 315-0303-00 | | RES,FXD,FILM:30K OHM,5%,0.25M | 19701 | 5043CX30K00J |
| A15R1721 | 315-0750-00 | | RES,FXD,FILM:75 OHM,5%,0.25M | 57668 | NTR25J-E75E0 |
| A15T1311 | 120-1349-00 | | TRANSFORMER,RF:ISOLATION | 80009 | 120-1349-00 |
| A15TP1421 | 214-0579-00 | | TERM,TEST POINT:BR5 CD PL | 80009 | 214-0579-00 |
| A15U1000 | 156-0067-00 | | MICROCKT,LINEAR:OPNL AMPL,SEL | 04713 | MC1741CP1 |
| A15U1020 | 156-0412-02 | | MICROCKT,DGTL:SYN 4 BIT UP/DOWN CNTR | 27014 | DW74LS193NA+ |
| A15U1030 | 156-0382-02 | | MICROCKT,DGTL:QUAD 2 IMP NAND GATE BURN | 18324 | N74LS00NB |
| A15U1120 | 156-0412-02 | | MICROCKT,DGTL:SYN 4 BIT UP/DOWN CNTR | 27014 | DW74LS193NA+ |

Replaceable Electrical Parts - DM 5010

| Component No. | Tektronix Part No. | Serial/Assembly No. Effective | Dscont | Name & Description | Mfr. Code | Mfr. Part No. |
|---------------|--------------------|-------------------------------|---------|---|-----------|------------------|
| A15U1125 | 156-0299-02 | | | MICROCKT,DGTL:TTL,16-BIT DATA SELECTOR | 18324 | N74150(NB OR FB) |
| A15U1130 | 156-0412-02 | | | MICROCKT,DGTL:SYN 4 BIT UP/DOWN CNTR | 27014 | DM74LS193NA+ |
| A15U1135 | 156-0386-02 | | | MICROCKT,DGTL:TRIPLE 3-INP NAND GATE | 07263 | 74LS10PCQR |
| A15U1220 | 156-0412-02 | | | MICROCKT,DGTL:SYN 4 BIT UP/DOWN CNTR | 27014 | DM74LS193NA+ |
| A15U1230 | 156-0567-02 | | | MICROCKT,DGTL:DUAL J-K NEG EDGE TRIG FF | 27014 | DM74LS113NA+ |
| A15U1235 | 156-0844-02 | | | MICROCKT,DGTL:SYN 4 BIT CNTR | 01295 | SN74LS161A(NP3) |
| A15U1320 | 156-0567-02 | | | MICROCKT,DGTL:DUAL J-K NEG EDGE TRIG FF | 27014 | DM74LS113NA+ |
| A15U1325 | 156-0567-02 | | | MICROCKT,DGTL:DUAL J-K NEG EDGE TRIG FF | 27014 | DM74LS113NA+ |
| A15U1330 | 156-0567-02 | | | MICROCKT,DGTL:DUAL J-K NEG EDGE TRIG FF | 27014 | DM74LS113NA+ |
| A15U1335 | 156-0464-02 | | | MICROCKT,DGTL:DUAL 4-INP NAND GATE | 01295 | SN74LS20NP3 |
| A15U1420 | 156-0382-02 | | | MICROCKT,DGTL:SYN 2 INP NAND GATE BURN | 18324 | N74LS00NB |
| A15U1425 | 156-0567-02 | | | MICROCKT,DGTL:DUAL J-K NEG EDGE TRIG FF | 27014 | DM74LS113NA+ |
| A15U1430 | 156-0382-02 | | | MICROCKT,DGTL:QUAD 2 INP NAND GATE BURN | 18324 | N74LS00NB |
| A15U1435 | 156-0480-02 | | | MICROCKT,DGTL:QUAD 2-INP & GATE | 01295 | SN74LS08NP3 |
| A15U1510 | 156-1522-00 | | | CPLR,OPTOELECTR:LED & PHOTOTRANSISTOR | 50434 | HCPL-2601 |
| A15U1515 | 156-1522-00 | | | CPLR,OPTOELECTR:LED & PHOTOTRANSISTOR | 50434 | HCPL-2601 |
| A15U1520 | 156-0382-02 | | | MICROCKT,DGTL:QUAD 2 INP NAND GATE BURN | 18324 | N74LS00NB |
| A15U1525 | 156-0545-01 | | | MICROCKT,DGTL:12 BIT BINARY CNTR | 02735 | CD4040BFX |
| A15U1530 | 156-0382-02 | | | MICROCKT,DGTL:QUAD 2 INP NAND GATE BURN | 18324 | N74LS00NB |
| A15U1535 | 156-0041-05 | B010100 | B021349 | MICROCKT,DGTL:DUAL D FLIP FLOP SCRN | 01295 | SN7474NP3 |
| A15U1535 | 156-0331-03 | B021350 | | MICROCKT,DGTL:DUAL D TYPE POSITIVE EDGE | 01295 | SN74LS74NP3 |
| A15U1605 | 156-0991-00 | | | MICROCKT,LINEAR:VOLTAGE REGULATOR | 04713 | MC78L05ACP |
| A15U1610 | 156-1522-00 | | | CPLR,OPTOELECTR:LED & PHOTOTRANSISTOR | 50434 | HCPL-2601 |
| A15U1613 | 156-0991-00 | | | MICROCKT,LINEAR:VOLTAGE REGULATOR | 04713 | MC78L05ACP |
| A15U1615 | 156-1522-00 | | | CPLR,OPTOELECTR:LED & PHOTOTRANSISTOR | 50434 | HCPL-2601 |
| A15U1620 | 156-0465-01 | | | MICROCKT,DGTL:8-INP NAND GATE,CHK | 80009 | 156-0465-01 |
| A15U1625 | 156-0465-01 | | | MICROCKT,DGTL:8-INP NAND GATE,CHK | 80009 | 156-0465-01 |
| A15U1630 | 156-0388-03 | | | MICROCKT,DGTL:DUAL D FLIP-FLOP | 01295 | SN74LS74ANP3 |
| A15U1635 | 156-0386-02 | | | MICROCKT,DGTL:TRIPLE 3-INP NAND GATE | 07263 | 74LS10PCQR |
| A15U1710 | 156-1522-00 | | | CPLR,OPTOELECTR:LED & PHOTOTRANSISTOR | 50434 | HCPL-2601 |
| A15U1720 | 156-0465-01 | | | MICROCKT,DGTL:8-INP NAND GATE,CHK | 80009 | 156-0465-01 |
| A15U1730 | 156-0784-02 | | | MICROCKT,DGTL:SYNCHRONOUS 4-BIT BINARY CNTR | 01295 | SN74LS163AN P3 |
| A15VR1001 | 152-0662-00 | | | SEMICONO DVC,DI:ZEN,SI,5V,1%,400MH,00-7 | 04713 | SZG195RL |
| A15VR1216 | 152-0279-00 | | | SEMICONO DVC,DI:ZEN,SI,5.1V,5%,0.4M,00-7 | 14552 | T03810989 |
| A16 | 670-6816-00 | | | CIRCUIT BD ASSY:RMS | 80009 | 670-6816-00 |
| A16C1001 | 285-0809-00 | | | CAP,FXD,PLASTIC:1UF,10%,50V | 56289 | LP66A1A105K |
| A16C1013 | 290-0768-00 | | | CAP,FXD,ELCTLT:10UF,+50-10%,100VDC | 54473 | ECE-A100V10L |
| A16C1101 | 290-0121-00 | | | CAP,FXD,ELCTLT:2UF,+75-10%,25V | 01002 | 76F92KC2R0 |
| A16C1103 | 290-0488-00 | | | CAP,FXD,ELCTLT:2.2UF,10%,20V | 05397 | T3228225K020AS |
| A16C1105 | 281-0775-00 | | | CAP,FXD,CER DI:0.1UF,20%,50V | 04222 | MA205E104MAA |
| A16C1107 | 281-0775-00 | | | CAP,FXD,CER DI:0.1UF,20%,50V | 04222 | MA205E104MAA |
| A16C1111 | 281-0775-00 | | | CAP,FXD,CER DI:0.1UF,20%,50V | 04222 | MA205E104MAA |
| A16C1113 | 281-0775-00 | | | CAP,FXD,CER DI:0.1UF,20%,50V | 04222 | MA205E104MAA |
| A16C1301 | 281-0775-00 | | | CAP,FXD,CER DI:0.1UF,20%,50V | 04222 | MA205E104MAA |
| A16C1303 | 281-0775-00 | | | CAP,FXD,CER DI:0.1UF,20%,50V | 04222 | MA205E104MAA |
| A16C1311 | 283-0593-00 | | | CAP,FXD,MICA DI:0.01UF,1%,100V | 00853 | D301F103F0 |
| A16C1403 | 281-0248-00 | | | CAP,VAR,AIR DI:1.8-10.16PF,75MVDC | 74970 | 186-0613-105 |
| A16C1405 | 283-0676-00 | | | CAP,FXD,MICA DI:82PF,1%,500V | 00853 | 0105E820F0 |
| A16C1415 | 281-0775-00 | | | CAP,FXD,CER DI:0.1UF,20%,50V | 04222 | MA205E104MAA |
| A16C1417 | 283-0203-00 | | | CAP,FXD,CER DI:0.47UF,20%,50V | 04222 | SR3055C474MAA |
| A16C1503 | 281-0064-00 | | | CAP,VAR,PLASTIC:0.25-1.5PF,600V | 52769 | ER-530-013 |
| A16C1505 | 281-0658-00 | B010100 | B010199 | CAP,FXD,CER DI:6.2PF,+/-0.25PF,500 | 52763 | 2RDPLZ007 8P20CC |
| A16C1505 | 281-0645-00 | B010200 | | CAP,FXD,CER DI:8.2PF,+/-0.25PF,500V | 52763 | 2RDPLZ007 8P20CC |
| A16C1513 | 281-0775-00 | | | CAP,FXD,CER DI:0.1UF,20%,50V | 04222 | MA205E104MAA |
| A16C1515 | 283-0203-00 | | | CAP,FXD,CER DI:0.47UF,20%,50V | 04222 | SR3055C474MAA |
| A16C1525 | 283-0203-00 | | | CAP,FXD,CER DI:0.47UF,20%,50V | 04222 | SR3055C474MAA |
| A16C1526 | 281-0775-00 | | | CAP,FXD,CER DI:0.1UF,20%,50V | 04222 | MA205E104MAA |
| A16C1527 | 283-0203-00 | | | CAP,FXD,CER DI:0.47UF,20%,50V | 04222 | SR3055C474MAA |
| A16C1528 | 281-0775-00 | | | CAP,FXD,CER DI:0.1UF,20%,50V | 04222 | MA205E104MAA |

| Component No. | Tektronix Part No. | Serial/Assembly No. Effective Dscont | Name & Description | Mfr. Code | Mfr. Part No. |
|---------------|--------------------|--------------------------------------|--|-----------|------------------|
| A16C1601 | 281-0775-00 | | CAP,FXD,CER DI:0.1UF,20%,50V | 04222 | MA205E104MAA |
| A16C1603 | 281-0775-00 | | CAP,FXD,CER DI:0.1UF,20%,50V | 04222 | MA205E104MAA |
| A16C1605 | 281-0064-00 | | CAP,VAR,PLASTIC:0.25-1.5PF,600V | 52769 | ER-530-013 |
| A16C1607 | 281-0064-00 | | CAP,VAR,PLASTIC:0.25-1.5PF,600V | 52769 | ER-530-013 |
| A16C1609 | 283-0342-00 | | CAP,FXD,CER DI:6.5PF,0.5%,2000V | 59660 | 838564COH0659D |
| A16C1621 | 285-1077-00 | | CAP,FXD,PLASTIC:0.1UF,20%,600V | 14752 | Z3081F104M |
| A16CR1011 | 152-0704-00 | | SEMICON DVC,DI:RECT,SI,1A,1KV,00-41 | 05828 | 1N4007G |
| A16CR1021 | 152-0141-02 | | SEMICON DVC,DI:SM,SI,30V,150MA,30V | 03508 | 0A2527 (1N4152) |
| A16CR1023 | 152-0141-02 | | SEMICON DVC,DI:SM,SI,30V,150MA,30V | 03508 | 0A2527 (1N4152) |
| A16CR1121 | 152-0141-02 | | SEMICON DVC,DI:SM,SI,30V,150MA,30V | 03508 | 0A2527 (1N4152) |
| A16CR1225 | 152-0704-00 | | SEMICON DVC,DI:RECT,SI,1A,1KV,00-41 | 05828 | 1N4007G |
| A16CR1227 | 152-0141-02 | | SEMICON DVC,DI:SM,SI,30V,150MA,30V | 03508 | 0A2527 (1N4152) |
| A16CR1231 | 152-0141-02 | | SEMICON DVC,DI:SM,SI,30V,150MA,30V | 03508 | 0A2527 (1N4152) |
| A16CR1233 | 152-0141-02 | | SEMICON DVC,DI:SM,SI,30V,150MA,30V | 03508 | 0A2527 (1N4152) |
| A16CR1415 | 152-0141-02 | | SEMICON DVC,DI:SM,SI,30V,150MA,30V | 03508 | 0A2527 (1N4152) |
| A16CR1511 | 152-0141-02 | | SEMICON DVC,DI:SM,SI,30V,150MA,30V | 03508 | 0A2527 (1N4152) |
| A16CR1513 | 152-0141-02 | | SEMICON DVC,DI:SM,SI,30V,150MA,30V | 03508 | 0A2527 (1N4152) |
| A16CR1527 | 152-0141-02 | | SEMICON DVC,DI:SM,SI,30V,150MA,30V | 03508 | 0A2527 (1N4152) |
| A16CR1529 | 152-0141-02 | | SEMICON DVC,DI:SM,SI,30V,150MA,30V | 03508 | 0A2527 (1N4152) |
| A16CR1613 | 152-0323-00 | | SEMICON DVC,DI:SM,SI,35V,0.1A,00-7 | 14433 | MG1518 |
| A16CR1615 | 152-0323-00 | | SEMICON DVC,DI:SM,SI,35V,0.1A,00-7 | 14433 | MG1518 |
| A16K1031 | 148-0141-00 | | RELAY,REED:1 FORM A,0.5A,100VDC,COIL 15VDC, 2.2K OHM | 15636 | R7620-2 |
| A16K1131 | 148-0141-00 | | RELAY,REED:1 FORM A,0.5A,100VDC,COIL 15VDC, 2.2K OHM | 15636 | R7620-2 |
| A16K1201 | 148-0126-00 | | RELAY,REED:FORM A,00MA,250VDC,COIL 5VDC | 15636 | R6895-1 |
| A16K1231 | 148-0141-00 | | RELAY,REED:1 FORM A,0.5A,100VDC,COIL 15VDC, 2.2K OHM | 15636 | R7620-2 |
| A16K1313 | 148-0126-00 | | RELAY,REED:FORM A,00MA,250VDC,COIL 5VDC | 15636 | R6895-1 |
| A16K1405 | 148-0126-00 | | RELAY,REED:FORM A,00MA,250VDC,COIL 5VDC | 15636 | R6895-1 |
| A16K1503 | 148-0126-00 | | RELAY,REED:FORM A,00MA,250VDC,COIL 5VDC | 15636 | R6895-1 |
| A16K1621 | 148-0141-00 | | RELAY,REED:1 FORM A,0.5A,100VDC,COIL 15VDC, 2.2K OHM | 15636 | R7620-2 |
| A16K1633 | 148-0141-00 | | RELAY,REED:1 FORM A,0.5A,100VDC,COIL 15VDC, 2.2K OHM | 15636 | R7620-2 |
| A16Q1021 | 151-1131-00 | | TRANSISTOR:FE,N-CHANNEL,SI,T0-72C | 17856 | FN4582 |
| A16Q1320 | 156-1527-00 | | MICROCKT,LINEAR:5 XSTR ARRAY | 02735 | CA3183AE-98 |
| A16Q1420 | 156-1527-00 | | MICROCKT,LINEAR:5 XSTR ARRAY | 02735 | CA3183AE-98 |
| A16R1001 | 311-1337-00 | | RES,VAR,NONMM:TRMR,25K OHM,0.5M | 32997 | 3006P-M84-253 |
| A16R1003 | 315-0103-00 | | RES,FXD,FILM:10K OHM,5%,0.25M | 19701 | 5043CX10K00J |
| A16R1013 | 315-0103-00 | | RES,FXD,FILM:10K OHM,5%,0.25M | 19701 | 5043CX10K00J |
| A16R1021 | 315-0101-00 | | RES,FXD,FILM:100 OHM,5%,0.25M | 57668 | NTR25J-E 100E |
| A16R1031 | 325-0355-00 | | RES,FXD,FILM:1M OHM,0.1%,0.25M | 91637 | PTF65T16100038 |
| A16R1032 | 315-0162-00 | | RES,FXD,FILM:1.6K OHM,5%,0.25M | 19701 | 5043CX1K600J |
| A16R1033 | 321-1389-07 | | RES,FXD,FILM:111K OHM,0.1%,0.125M,TC=T9 | 19701 | 5033RE111388298F |
| A16R1101 | 321-0959-03 | | RES,FXD,FILM:24.01K OHM,0.25%,0.125M,T2 | 24546 | NC55C24.01KC |
| A16R1121 | 321-0908-02 | | RES,FXD,FILM:1.31K OHM,0.5%,0.125M,TC=T2 | 24546 | NC55C13110 |
| A16R1123 | 321-1310-03 | | RES,FXD,FILM:16.7K OHM,0.25%,0.125M,TC=T2 | 19701 | 5033RC16K72C |
| A16R1201 | 321-0318-07 | | RES,FXD,FILM:20.0K OHM,0.1%,0.125M,TC=T9 | 19701 | 5033RE20K008CM |
| A16R1211 | 321-0703-00 | | RES,FXD,FILM:2.19K OHM,0.25%,0.125M,T0=T9 | 19701 | 5033RE2K190C |
| A16R1221 | 321-0289-00 | | RES,FXD,FILM:10.0K OHM,1%,0.125M,TC=T0 | 19701 | 5033ED10K0F |
| A16R1223 | 321-0364-03 | | RES,FXD,FILM:60.4K OHM,0.25%,0.125M,T=T2 | 19701 | 5033RC60K40C |
| A16R1225 | 321-0481-01 | | RES,FXD,FILM:1M OHM,0.5%,0.125M,TC=T0 | 07716 | CEAD100030 |
| A16R1229 | 323-0443-01 | | RES,FXD,FILM:402K OHM,0.5%,0.5M,TC=T0 | 24546 | NA650 40230 |
| A16R1231 | 315-0162-00 | | RES,FXD,FILM:1.6K OHM,5%,0.25M | 19701 | 5043CX1K600J |
| A16R1233 | 315-0162-00 | | RES,FXD,FILM:1.6K OHM,5%,0.25M | 19701 | 5043CX1K600J |
| A16R1303 | 315-0184-00 | | RES,FXD,FILM:180K OHM,5%,0.25M | 19701 | 5043CX180K0J |
| A16R1305 | 311-1337-00 | | RES,VAR,NONMM:TRMR,25K OHM,0.5M | 32997 | 3006P-M84-253 |
| A16R1307 | 321-0222-07 | | RES,FXD,FILM:2.0K OHM,0.1%,0.125M,TC=T9 | 19701 | 5033RE2K0008 |

Replaceable Electrical Parts - DM 5010

| Component No. | Tektronix Part No. | Serial/Assembly No. Effective | Discont | Name & Description | Mfr. Code | Mfr. Part No. |
|---------------|--------------------|-------------------------------|---------|---|-----------|------------------|
| A16R1309 | 321-0222-07 | | | RES,FXD,FILM:2.0K OHM,0.1%,0.125M,TC=T9 | 19701 | 5033RE2K0008 |
| A16R1321 | 323-0445-01 | | | RES,FXD,FILM:422K,OHM,0.5%,0.5M,TC=T0 | 24546 | NA60D 4223D |
| A16R1323 | 322-0254-02 | | | RES,FXD,FILM:4.32K OHM,0.5%,0.25M,TC=T2 | 24546 | NC60C4321C |
| A16R1325 | 315-0562-00 | | | RES,FXD,FILM:5.6K OHM,5%,0.25M | 57668 | NTR25J-E05K6 |
| A16R1327 | 315-0562-00 | | | RES,FXD,FILM:5.6K OHM,5%,0.25M | 57668 | NTR25J-E05K6 |
| A16R1331 | 325-0354-00 | | | RES,FXD,FILM:10K OHM,0.1%,0.25M | 19701 | 5033ZA10K008 |
| A16R1333 | 325-0349-00 | | | RES,FXD,FILM:10M OHM,0.25%,0.5M,TC=T9 | 03888 | PME7D 10M0HM.25% |
| A16R1401 | 321-1610-03 | | | RES,FXD,FILM:22.22K OHM,0.25%,0.125M,TC=T2 | 19701 | 5033RC22K22D |
| A16R1403 | 321-0414-07 | | | RES,FXD,FILM:200K OHM,0.1%,0.125M,TC=T9 | 24546 | NE55E2003B |
| A16R1415 | 321-1133-02 | | | RES,FXD,FILM:240 OHM,0.5%,0.125M,TC=T2 | 24546 | NC60D2400D |
| A16R1421 | 315-0562-00 | | | RES,FXD,FILM:5.6K OHM,5%,0.25M | 57668 | NTR25J-E05K6 |
| A16R1423 | 315-0562-00 | | | RES,FXD,FILM:5.6K OHM,5%,0.25M | 57668 | NTR25J-E05K6 |
| A16R1425 | 315-0562-00 | | | RES,FXD,FILM:5.6K OHM,5%,0.25M | 57668 | NTR25J-E05K6 |
| A16R1426 | 315-0562-00 | | | RES,FXD,FILM:5.6K OHM,5%,0.25M | 57668 | NTR25J-E05K6 |
| A16R1427 | 315-0562-00 | | | RES,FXD,FILM:5.6K OHM,5%,0.25M | 57668 | NTR25J-E05K6 |
| A16R1429 | 315-0562-00 | | | RES,FXD,FILM:5.6K OHM,5%,0.25M | 57668 | NTR25J-E05K6 |
| A16R1501 | 321-0510-07 | | | RES,FXD,FILM:2.00 MEG OHM,0.1%,0.125M,TC=T0 | 19701 | 5033RE2M008 |
| A16R1521 | 315-0562-00 | | | RES,FXD,FILM:5.6K OHM,5%,0.25M | 57668 | NTR25J-E05K6 |
| A16R1523 | 315-0122-00 | | | RES,FXD,FILM:1.2K OHM,5%,0.25M | 57668 | NTR25J-E01K2 |
| A16R1525 | 315-0122-00 | | | RES,FXD,FILM:1.2K OHM,5%,0.25M | 57668 | NTR25J-E01K2 |
| A16R1601 | 311-1337-00 | | | RES,VAR,NONPM:TRMR,25K OHM,0.5M | 32997 | 3006P-W84-253 |
| A16R1603 | 323-0510-07 | B010100 | B010709 | RES,FXD,FILM:2.0MEG OHM,0.1%,0.5M,TC=T9 | 91637 | CMF65116-C200038 |
| A16R1603 | 325-0385-00 | B010710 | | RES,FXD,FILM:2M OHM,0.1%,0.5M,TC=T9 | 03888 | PME7D 2M0HM .1% |
| A16R1609 | 321-0306-00 | | | RES,FXD,FILM:15.0K OHM,1%,0.125M,TC=T0 | 19701 | 5033ED15J00F |
| A16R1621 | 315-0201-02 | | | RES,FXD,CMPSN:200 OHM,5%,0.25M | 01121 | CB2015 |
| A16R1633 | 315-0102-00 | | | RES,FXD,FILM:1K OHM,5%,0.25M | 57668 | NTR25JE01K0 |
| A16RT1011 | 307-0662-00 | | | RES,THERMAL:1K OHM,40% | 50157 | 180Q10216 |
| A16RT1227 | 307-0767-00 | | | RES,THERMAL:5K OHM,+40%-20% | 50157 | 180Q50203 |
| A16TP1201 | 214-0579-00 | | | TERM,TEST POINT:BRS CD PL | 80009 | 214-0579-00 |
| A16TP1503 | 214-0579-00 | | | TERM,TEST POINT:BRS CD PL | 80009 | 214-0579-00 |
| A16TP1701 | 214-0579-00 | | | TERM,TEST POINT:BRS CD PL | 80009 | 214-0579-00 |
| A16TP1703 | 214-0579-00 | | | TERM,TEST POINT:BRS CD PL | 80009 | 214-0579-00 |
| A16U1100 | 156-1457-01 | | | MICROCKT,LINEAR:TRUE RMS TO DC CONVERTER, | 24355 | AD41134 |
| A16U1120 | 156-1149-01 | | | MICROCKT,LINEAR:OPERATION AMP JFET INPUT | 27014 | AL160307 |
| A16U1200 | 156-0742-01 | | | MICROCKT,LINEAR:OPNL AMPL,FUNCTIONAL TEST | 80009 | 156-0742-01 |
| A16U1330 | 156-0796-00 | | | MICROCKT,DGTL:8 STG SHF & STORE BUS RGTR | 02735 | CD40948F |
| A16U1417 | 156-1529-00 | | | MICROCKT,LINEAR:3-TERM ADJ OUT POS V RGLTR | 04713 | LM317LZ |
| A16U1430 | 156-0796-00 | | | MICROCKT,DGTL:8 STG SHF & STORE BUS RGTR | 02735 | CD40948F |
| A16U1500 | 156-1156-00 | | | MICROCKT,LINEAR:OPERATIONAL AMPLIFIER | 27014 | LF356N |
| A16U1515 | 156-0991-00 | | | MICROCKT,LINEAR:VOLTAGE REGULATOR | 04713 | MC78L05ACP |
| A16U1525 | 156-1207-00 | | | MICROCKT,LINEAR:VOLTAGE REGULATOR,-12 V | 04713 | MC79L12ACG |
| A16U1527 | 156-1160-00 | | | MICROCKT,LINEAR:VOLTAGE REGULATOR | 04713 | MC78L12ACG |
| A16U1530 | 156-0480-02 | | | MICROCKT,DGTL:QUAD 2-INP & GATE | 01295 | SN74LS08NP3 |
| A16VR1013 | 152-0278-00 | | | SEMICOND DVC,DI:ZEN,SI,3V,5%,0.4M,DO-7 | 04713 | SZ635009K20 |
| A16VR1123 | 152-0611-00 | | | SEMICOND DVC,DI:ZEN,SI,9V,2%,0.4M,DO-7 | 04713 | SZ14347 |
| A16VR1415 | 152-0278-00 | | | SEMICOND DVC,DI:ZEN,SI,3V,5%,0.4M,DO-7 | 04713 | SZ635009K20 |
| A16M1105 | 131-0566-00 | | | BUS,CONO:DUMMY RES,0.094 OD X 0.225L | 24546 | OMA 07 |
| A17 | 672-1015-00 | B010100 | B020979 | CIRCUIT BD ASSY:RELAY | 80009 | 672-1015-00 |
| A17 | 672-1015-01 | B020980 | B021903 | CIRCUIT BD ASSY:RELAY | 80009 | 672-1015-01 |
| A17 | 672-1015-03 | B021904 | | CIRCUIT BD ASSY:RELAY | 80009 | 672-1015-03 |
| A17C1001 | 281-0775-00 | | | CAP,FXD,CER DI:0.1UF,20%,50V | 04222 | MA205E104MAA |
| A17C1013 | 281-0775-00 | | | CAP,FXD,CER DI:0.1UF,20%,50V | 04222 | MA205E104MAA |
| A17C1017 | 281-0770-00 | | | CAP,FXD,CER DI:1000PF,20%,100V | 04222 | MA101C102MAA |
| A17C1019 | 281-0770-00 | | | CAP,FXD,CER DI:1000PF,20%,100V | 04222 | MA101C102MAA |
| A17C1021 | 290-0770-00 | B010100 | B010369 | CAP,FXD,ELCTLT:100UF,+50-10%,25VDC | 54473 | ECE-A25V100L |
| A17C1031 | 290-0770-00 | B010100 | B010369 | CAP,FXD,ELCTLT:100UF,+50-10%,25VDC | 54473 | ECE-A25V100L |
| A17C1123 | 281-0775-00 | | | CAP,FXD,CER DI:0.1UF,20%,50V | 04222 | MA205E104MAA |
| A17C1126 | 281-0811-00 | | | CAP,FXD,CER DI:10PF,10%,100V | 04222 | MA101A100KAA |
| A17C1128 | 281-0775-00 | | | CAP,FXD,CER DI:0.1UF,20%,50V | 04222 | MA205E104MAA |

| Component No. | Tektronix | | Serial/Assembly No. | | Name & Description | Mfr. Code | Mfr. Part No. |
|---------------|-------------|-----------|---------------------|--|---|-----------|-----------------|
| | Part No. | Effective | Dscont | | | | |
| A17C1131 | 281-0775-00 | | | | CAP,FXD,CER DI:0.1UF,20%,50V | 04222 | MA205E104MAA |
| A17C1133 | 290-0770-00 | 8010100 | 8010369 | | CAP,FXD,ELCTLT:100UF,+50-10%,25VDC | 54473 | ECE-A25V100L |
| A17C1135 | 290-0770-00 | 8010100 | 8010369 | | CAP,FXD,ELCTLT:100UF,+50-10%,25VDC | 54473 | ECE-A25V100L |
| A17C1137 | 281-0775-00 | | | | CAP,FXD,CER DI:0.1UF,20%,50V | 04222 | MA205E104MAA |
| A17C1139 | 285-0809-00 | | | | CAP,FXD,PLASTIC:1UF,10%,50V | 56289 | LP66A1A105K |
| A17C1202 | 281-0786-00 | | | | CAP,FXD,CER DI:150PF,10%,100V | 04222 | MA101A151KAA |
| A17C1204 | 281-0786-00 | | | | CAP,FXD,CER DI:150PF,10%,100V | 04222 | MA101A151KAA |
| A17C1206 | 281-0786-00 | | | | CAP,FXD,CER DI:150PF,10%,100V | 04222 | MA101A151KAA |
| A17C1211 | 281-0786-00 | | | | CAP,FXD,CER DI:150PF,10%,100V | 04222 | MA101A151KAA |
| A17C1221 | 283-0601-00 | | | | CAP,FXD,MICA DI:22PF,10%,300V | 00853 | D155E220K0 |
| A17C1225 | 285-1220-00 | | | | CAP,FXD,PLASTIC:1200PF,10%,200V | 14752 | A1509 |
| A17C1311 | 281-0786-00 | | | | CAP,FXD,CER DI:150PF,10%,100V | 04222 | MA101A151KAA |
| A17C1312 | 281-0786-00 | | | | CAP,FXD,CER DI:150PF,10%,100V | 04222 | MA101A151KAA |
| A17C1323 | 281-0775-00 | | | | CAP,FXD,CER DI:0.1UF,20%,50V | 04222 | MA205E104MAA |
| A17C1331 | 290-0770-00 | | | | CAP,FXD,ELCTLT:100UF,+50-10%,25VDC | 54473 | ECE-A25V100L |
| A17C1411 | 281-0786-00 | | | | CAP,FXD,CER DI:150PF,10%,100V | 04222 | MA101A151KAA |
| A17C1412 | 281-0786-00 | | | | CAP,FXD,CER DI:150PF,10%,100V | 04222 | MA101A151KAA |
| A17C1513 | 281-0775-00 | | | | CAP,FXD,CER DI:0.1UF,20%,50V | 04222 | MA205E104MAA |
| A17C1514 | 290-0177-00 | | | | CAP,FXD,ELCTLT:1UF,20%,50V | 05397 | T320A105M050AS |
| A17C1601 | 281-0775-00 | | | | CAP,FXD,CER DI:0.1UF,20%,50V | 04222 | MA205E104MAA |
| A17C1602 | 283-0203-00 | | | | CAP,FXD,CER DI:0.47UF,20%,50V | 04222 | SR3055C474MAA |
| A17C1603 | 281-0775-00 | | | | CAP,FXD,CER DI:0.1UF,20%,50V | 04222 | MA205E104MAA |
| A17C1604 | 283-0203-00 | | | | CAP,FXD,CER DI:0.47UF,20%,50V | 04222 | SR3055C474MAA |
| A17C1605 | 281-0775-00 | | | | CAP,FXD,CER DI:0.1UF,20%,50V | 04222 | MA205E104MAA |
| A17C1606 | 283-0203-00 | | | | CAP,FXD,CER DI:0.47UF,20%,50V | 04222 | SR3055C474MAA |
| A17C1611 | 281-0775-00 | | | | CAP,FXD,CER DI:0.1UF,20%,50V | 04222 | MA205E104MAA |
| A17C1612 | 290-0177-00 | | | | CAP,FXD,ELCTLT:1UF,20%,50V | 05397 | T320A105M050AS |
| A17C1613 | 283-0212-00 | | | | CAP,FXD,CER DI:2UF,20%,50V | 04222 | SR405E205MAA |
| A17C1723 | 283-0109-00 | | | | CAP,FXD,CER DI:27PF,5%,1000V | 59660 | 858-534C0G0270J |
| A17CR1111 | 152-0141-02 | | | | SEMICON DVC,DI:SM,SI,30V,150MA,30V | 03508 | DA2527 (1N4152) |
| A17CR1113 | 152-0141-02 | | | | SEMICON DVC,DI:SM,SI,30V,150MA,30V | 03508 | DA2527 (1N4152) |
| A17CR1121 | 153-0057-00 | 8010100 | 8021469 | | SEMICON DVC,DI:SELECTED | 80009 | 153-0057-00 |
| A17CR1121 | 152-0323-00 | 8021470 | | | SEMICON DVC,DI:SM,SI,35V,0.1A,00-7 | 14433 | MG 1518 |
| A17CR1122 | 153-0057-00 | 8010100 | 8021469 | | SEMICON DVC,DI:SELECTED | 80009 | 153-0057-00 |
| A17CR1122 | 152-0323-00 | 8021470 | | | SEMICON DVC,DI:SM,SI,35V,0.1A,00-7 | 14433 | MG 1518 |
| A17CR1123 | 153-0057-00 | 8010100 | 8021469 | | SEMICON DVC,DI:SELECTED | 80009 | 153-0057-00 |
| A17CR1123 | 152-0323-00 | 8021470 | | | SEMICON DVC,DI:SM,SI,35V,0.1A,00-7 | 14433 | MG 1518 |
| A17CR1125 | 153-0057-00 | 8010100 | 8021469 | | SEMICON DVC,DI:SELECTED | 80009 | 153-0057-00 |
| A17CR1125 | 152-0323-00 | 8021470 | | | SEMICON DVC,DI:SM,SI,35V,0.1A,00-7 | 14433 | MG 1518 |
| A17CR1129 | 152-0141-02 | | | | SEMICON DVC,DI:SM,SI,30V,150MA,30V | 03508 | DA2527 (1N4152) |
| A17CR1221 | 153-0057-00 | 8010100 | 8021469 | | SEMICON DVC,DI:SELECTED | 80009 | 153-0057-00 |
| A17CR1221 | 152-0323-00 | 8021470 | | | SEMICON DVC,DI:SM,SI,35V,0.1A,00-7 | 14433 | MG 1518 |
| A17CR1223 | 153-0057-00 | 8010100 | 8021469 | | SEMICON DVC,DI:SELECTED | 80009 | 153-0057-00 |
| A17CR1223 | 152-0323-00 | 8021470 | | | SEMICON DVC,DI:SM,SI,35V,0.1A,00-7 | 14433 | MG 1518 |
| A17CR1419 | 152-0141-02 | | | | SEMICON DVC,DI:SM,SI,30V,150MA,30V | 03508 | DA2527 (1N4152) |
| A17CR1511 | 152-0141-02 | | | | SEMICON DVC,DI:SM,SI,30V,150MA,30V | 03508 | DA2527 (1N4152) |
| A17CR1517 | 152-0141-02 | | | | SEMICON DVC,DI:SM,SI,30V,150MA,30V | 03508 | DA2527 (1N4152) |
| A17CR1519 | 152-0141-02 | | | | SEMICON DVC,DI:SM,SI,30V,150MA,30V | 03508 | DA2527 (1N4152) |
| A17CR1611 | 152-0141-02 | | | | SEMICON DVC,DI:SM,SI,30V,150MA,30V | 03508 | DA2527 (1N4152) |
| A17CR1612 | 152-0141-02 | | | | SEMICON DVC,DI:SM,SI,30V,150MA,30V | 03508 | DA2527 (1N4152) |
| A17CR1621 | 152-0141-02 | | | | SEMICON DVC,DI:SM,SI,30V,150MA,30V | 03508 | DA2527 (1N4152) |
| A17CR1623 | 152-0141-02 | | | | SEMICON DVC,DI:SM,SI,30V,150MA,30V | 03508 | DA2527 (1N4152) |
| A17K1425 | 148-0141-00 | | | | RELAY,REED:1 FORM A,0.5A,100VDC,COIL 15VDC, 2.2K OHM | 15636 | R7620-2 |
| A17K1525 | 148-0141-00 | | | | RELAY,REED:1 FORM A,0.5A,100VDC,COIL 15VDC, 2.2K OHM | 15636 | R7620-2 |
| A17K1527 | 148-0141-00 | | | | RELAY,REED:1 FORM A,0.5A,100VDC,COIL 15VDC, 2.2K OHM | 15636 | R7620-2 |
| A17K1631 | ----- | | | | (RELAY,ARMATURE:4 FORM C,6V,2A) | | |

Replaceable Electrical Parts - DM 5010

| Component No. | Tektronix Part No. | Serial/Assembly No. Effective Dscont | Name & Description | Mfr. Code | Mfr. Part No. |
|---------------|--------------------|--------------------------------------|--|-----------|------------------|
| | | | (PART OF A17A1 ONLY) | | |
| A17L1723 | 108-1134-00 | | COIL,RF:FIXED,5.3UH | 80009 | 108-1134-00 |
| A17Q1001 | 151-0350-00 | | TRANSISTOR:PMP,SI,TO-92 | 04713 | SPS6700 |
| A17Q1015 | 151-0347-00 | | TRANSISTOR:NPN,SI,TO-92 | 04713 | SPS7951 |
| A17Q1017 | 151-0347-00 | | TRANSISTOR:NPN,SI,TO-92 | 04713 | SPS7951 |
| A17Q1021 | 151-0350-00 | | TRANSISTOR:PMP,SI,TO-92 | 04713 | SPS6700 |
| A17Q1101 | 151-0407-00 | | TRANSISTOR:NPN,SI,TO-39 | 04713 | 5S2456 |
| A17Q1105 | 151-1133-00 | | TRANSISTOR:FE,N-CHANNEL,SI,TO-18C | 17856 | FN4579 |
| A17Q1106 | 151-1133-00 | | TRANSISTOR:FE,N-CHANNEL,SI,TO-18C | 17856 | FN4579 |
| A17Q1111 | 151-0406-00 | | TRANSISTOR:PMP,SI,TO-39 | 04713 | ST1264 |
| A17Q1112 | 151-1133-00 | | TRANSISTOR:FE,N-CHANNEL,SI,TO-18C | 17856 | FN4579 |
| A17Q1114 | 151-1133-00 | | TRANSISTOR:FE,N-CHANNEL,SI,TO-18C | 17856 | FN4579 |
| A17Q1201 | 151-0347-00 | | TRANSISTOR:NPN,SI,TO-92 | 04713 | SPS7951 |
| A17Q1202 | 151-0347-00 | | TRANSISTOR:NPN,SI,TO-92 | 04713 | SPS7951 |
| A17Q1211 | 151-0347-00 | | TRANSISTOR:NPN,SI,TO-92 | 04713 | SPS7951 |
| A17Q1212 | 151-0347-00 | | TRANSISTOR:NPN,SI,TO-92 | 04713 | SPS7951 |
| A17Q1215 | 151-0347-00 | | TRANSISTOR:NPN,SI,TO-92 | 04713 | SPS7951 |
| A17Q1217 | 151-1134-00 | | TRANSISTOR:FE,N-CHANNEL,SI,TO-72 | 17856 | FN4594 |
| A17Q1222 | 151-1131-00 | | TRANSISTOR:FE,N-CHANNEL,SI,TO-72C | 17856 | FN4582 |
| A17Q1311 | 151-0347-00 | | TRANSISTOR:NPN,SI,TO-92 | 04713 | SPS7951 |
| A17Q1313 | 151-0347-00 | | TRANSISTOR:NPN,SI,TO-92 | 04713 | SPS7951 |
| A17Q1315 | 151-1134-00 | | TRANSISTOR:FE,N-CHANNEL,SI,TO-72 | 17856 | FN4594 |
| A17Q1317 | 151-1134-00 | | TRANSISTOR:FE,N-CHANNEL,SI,TO-72 | 17856 | FN4594 |
| A17Q1319 | 151-1134-00 | | TRANSISTOR:FE,N-CHANNEL,SI,TO-72 | 17856 | FN4594 |
| A17Q1321 | 151-1131-00 | | TRANSISTOR:FE,N-CHANNEL,SI,TO-72C | 17856 | FN4582 |
| A17Q1323 | 151-1131-00 | | TRANSISTOR:FE,N-CHANNEL,SI,TO-72C | 17856 | FN4582 |
| A17Q1327 | 151-1131-00 | | TRANSISTOR:FE,N-CHANNEL,SI,TO-72C | 17856 | FN4582 |
| A17Q1411 | 151-0347-00 | | TRANSISTOR:NPN,SI,TO-92 | 04713 | SPS7951 |
| A17Q1413 | 151-0347-00 | | TRANSISTOR:NPN,SI,TO-92 | 04713 | SPS7951 |
| A17Q1511 | 151-0301-00 | | TRANSISTOR:PMP,SI,TO-18 | 04713 | 5T898 |
| A17Q1512 | 151-0190-00 | | TRANSISTOR:NPN,SI,TO-92 | 80009 | 151-0190-00 |
| A17Q1513 | 151-0347-00 | | TRANSISTOR:NPN,SI,TO-92 | 04713 | SPS7951 |
| A17Q1514 | 151-1066-00 | | TRANSISTOR:FET,P-CHAN,SI,TO-92 | 04713 | SPF3038 |
| A17Q1515 | 151-0347-00 | | TRANSISTOR:NPN,SI,TO-92 | 04713 | SPS7951 |
| A17Q1611 | 151-0254-00 | | TRANSISTOR:DARLINGTON,NPN,SI | 03508 | X38L3118 |
| A17Q1613 | 151-0134-00 | | TRANSISTOR:PMP,SI,TO-39 | 04713 | SM3195 |
| A17R1001 | 321-0178-00 | | RES,FXD,FILM:698 OHM,1%,0.125M,TC=TO | 07716 | CEAD698R0F |
| A17R1011 | 315-0513-00 | | RES,FXD,FILM:51K OHM,5%,0.25M | 57668 | NTR25J-E51K0 |
| A17R1013 | 321-0178-00 | | RES,FXD,FILM:698 OHM,1%,0.125M,TC=TO | 07716 | CEAD698R0F |
| A17R1033 | 315-0432-00 | | RES,FXD,FILM:4.3K OHM,5%,0.25M | 57668 | NTR25J-E04K3 |
| A17R1101 | 325-0350-00 | | RES,FXD,FILM:5.9K OHM,0.1%,0.125M | 19701 | 5033Z45K9008 |
| A17R1102 | 325-0351-00 | | RES,FXD,FILM:53K OHM,0.1%,0.125M | 19701 | 5033Z453K008 |
| A17R1103 | 315-0513-00 | | RES,FXD,FILM:51K OHM,5%,0.25M | 57668 | NTR25J-E51K0 |
| A17R1104 | 315-0105-00 | | RES,FXD,FILM:1M OHM,5%,0.25M | 19701 | 5043CX1M000J |
| A17R1115 | 315-0562-00 | | RES,FXD,FILM:5.6K OHM,5%,0.25M | 57668 | NTR25J-E05K6 |
| A17R1116 | 315-0104-00 | | RES,FXD,FILM:100K OHM,5%,0.25M | 57668 | NTR25J-E100K |
| A17R1117 | 315-0510-00 | | RES,FXD,FILM:51 OHM,5%,0.25M | 19701 | 5043CX51R00J |
| A17R1120 | 321-0983-00 | B010370 | RES,FXD,FILM:4.5 MEG OHM,1%,0.125M,TC=TO | 91637 | CMF55116-G45003F |
| A17R1121 | 315-0303-00 | | RES,FXD,FILM:30K OHM,5%,0.25M | 19701 | 5043CX30K00J |
| A17R1122 | 315-0510-00 | | RES,FXD,FILM:51 OHM,5%,0.25M | 19701 | 5043CX51R00J |
| A17R1124 | 315-0243-00 | | RES,FXD,FILM:24K OHM,5%,0.25M | 57668 | NTR25J-E24K0 |
| A17R1125 | 315-0432-00 | | RES,FXD,FILM:4.3K OHM,5%,0.25M | 57668 | NTR25J-E04K3 |
| A17R1126 | 315-0432-00 | | RES,FXD,FILM:4.3K OHM,5%,0.25M | 57668 | NTR25J-E04K3 |
| A17R1129 | 315-0362-00 | | RES,FXD,FILM:3.6K OHM,5%,0.25M | 19701 | 5043CX3K600J |
| A17R1139 | 315-0472-00 | | RES,FXD,FILM:4.7K OHM,5%,0.25M | 57668 | NTR25J-E04K7 |
| A17R1201 | 315-0363-00 | | RES,FXD,FILM:36K OHM,5%,0.25M | 57668 | NTR25J-E36K0 |
| A17R1203 | 315-0363-00 | | RES,FXD,FILM:36K OHM,5%,0.25M | 57668 | NTR25J-E36K0 |
| A17R1205 | 315-0363-00 | | RES,FXD,FILM:36K OHM,5%,0.25M | 57668 | NTR25J-E36K0 |
| A17R1207 | 315-0363-00 | | RES,FXD,FILM:36K OHM,5%,0.25M | 57668 | NTR25J-E36K0 |

| Component No. | Tektronix Part No. | Serial/Assembly No. Effective | Dscont | Name & Description | Mfr. Code | Mfr. Part No. |
|---------------|--------------------|-------------------------------|---------|---|-----------|------------------|
| A17R1212 | 315-0105-00 | | | RES,FXD,FILM:1M OHM,5%,0.25M | 19701 | 5043CX1M000J |
| A17R1213 | 321-0685-00 | | | RES,FXD,FILM:30K OHM,0.5%,0.125M,TC=T2 | 19701 | 5033RC30K000 |
| A17R1214 | 321-1427-02 | | | RES,FXD,FILM:277K OHM,0.5%,0.125M,TC=T2 | 19701 | 5033RC277K000 |
| A17R1215 | 321-0646-00 | | | RES,FXD,FILM:200K OHM,0.5%,0.125M,TC=T2 | 07716 | CEAC2000ZD |
| A17R1222 | 315-0243-00 | | | RES,FXD,FILM:24K OHM,5%,0.25M | 57668 | NTR25J-E24K0 |
| A17R1223 | 315-0752-00 | | | RES,FXD,FILM:7.5K OHM,5%,0.25M | 57668 | NTR25J-E07K5 |
| A17R1225 | 315-0752-00 | | | RES,FXD,FILM:7.5K OHM,5%,0.25M | 57668 | NTR25J-E07K5 |
| A17R1227 | 315-0473-00 | | | RES,FXD,FILM:47K OHM,5%,0.25M | 57668 | NTR25J-E47K0 |
| A17R1228 | 321-0510-00 | 8010100 | 8010769 | RES,FXD,FILM:2.00M OHM,1%,0.125M,TC=T0 | 03888 | PME55020003F |
| A17R1229 | 325-0352-00 | 8010100 | 8010769 | RES,FXD,FILM:71.5K OHM,0.1%,0.125M | 19701 | 5033ZA71K508 |
| A17R1229 | 325-0353-00 | 8010770 | | RES,FXD,FILM:90K OHM,0.1%,0.125M | 19701 | 5033ZA90K008 |
| A17R1231 | 325-0353-00 | 8010100 | 8010769 | RES,FXD,FILM:90K OHM,0.1%,0.125M | 19701 | 5033ZA90K008 |
| A17R1231 | 325-0384-00 | 8010770 | | RES,FXD,FILM:117K OHM,0.1%,0.125M,TC=T16 | 19701 | 5023ZA117K08 |
| A17R1233 | 321-0361-00 | | | RES,FXD,FILM:56.2K OHM,1%,0.125M,TC=T0 | 07716 | CEAD56201F |
| A17R1301 | 307-0839-00 | | | RES,FXD,FILM:200K OHM,1%,3M,TC=250PPM/DEG C | 07716 | GS3 200K OHM+-1% |
| A17R1313 | 315-0363-00 | | | RES,FXD,FILM:36K OHM,5%,0.25M | 57668 | NTR25J-E36K0 |
| A17R1314 | 315-0363-00 | | | RES,FXD,FILM:36K OHM,5%,0.25M | 57668 | NTR25J-E36K0 |
| A17R1315 | 315-0203-00 | | | RES,FXD,FILM:20K OHM,5%,0.25M | 57668 | NTR25J-E 20K |
| A17R1316 | 315-0203-00 | | | RES,FXD,FILM:20K OHM,5%,0.25M | 57668 | NTR25J-E 20K |
| A17R1321 | 321-0182-00 | | | RES,FXD,FILM:768 OHM,1%,0.125M,TC=T0 | 07716 | CEAD768R0F |
| A17R1323 | 315-0271-00 | | | RES,FXD,FILM:270 OHM,5%,0.25M | 57668 | NTR25J-E270E |
| A17R1331 | 315-0123-00 | | | RES,FXD,FILM:12K OHM,5%,0.25M | 57668 | NTR25J-E12K0 |
| A17R1413 | 315-0363-00 | | | RES,FXD,FILM:36K OHM,5%,0.25M | 57668 | NTR25J-E36K0 |
| A17R1414 | 315-0363-00 | | | RES,FXD,FILM:36K OHM,5%,0.25M | 57668 | NTR25J-E36K0 |
| A17R1415 | 315-0104-00 | | | RES,FXD,FILM:100K OHM,5%,0.25M | 57668 | NTR25J-E100K |
| A17R1416 | 315-0203-00 | | | RES,FXD,FILM:20K OHM,5%,0.25M | 57668 | NTR25J-E 20K |
| A17R1417 | 315-0562-00 | | | RES,FXD,FILM:5.6K OHM,5%,0.25M | 57668 | NTR25J-E05K6 |
| A17R1418 | 321-0646-00 | | | RES,FXD,FILM:200K OHM,0.5%,0.125M,TC=T2 | 07716 | CEAC2000ZD |
| A17R1419 | 315-0162-00 | | | RES,FXD,FILM:1.6K OHM,5%,0.25M | 19701 | 5043CX1K600J |
| A17R1427 | 321-0645-00 | | | RES,FXD,FILM:100K OHM,0.5%,0.125M,TC=T2 | 19701 | 5033RC10030 |
| A17R1429 | 307-0769-00 | | | RES NTMK,FXD,FI:1,9.9M OHM,90K OHM,10K OHM,0.25M,1200VDC | 19647 | 1776-9 |
| A17R1501 | 315-0272-00 | | | RES,FXD,FILM:2.7K OHM,5%,0.25M | 57668 | NTR25J-E02K7 |
| A17R1511 | 315-0473-00 | | | RES,FXD,FILM:47K OHM,5%,0.25M | 57668 | NTR25J-E47K0 |
| A17R1512 | 315-0242-00 | | | RES,FXD,FILM:2.4K OHM,5%,0.25M | 57668 | NTR25J-E02K4 |
| A17R1513 | 315-0102-00 | | | RES,FXD,FILM:1K OHM,5%,0.25M | 57668 | NTR25J-E01K0 |
| A17R1514 | 315-0364-00 | | | RES,FXD,FILM:360K OHM,5%,0.25M | 57668 | NTR25J-E360K |
| A17R1515 | 315-0132-00 | | | RES,FXD,FILM:1.3K OHM,5%,0.25M | 57668 | NTR25J-E01K3 |
| A17R1516 | 315-0562-00 | | | RES,FXD,FILM:5.6K OHM,5%,0.25M | 57668 | NTR25J-E05K6 |
| A17R1517 | 315-0162-00 | | | RES,FXD,FILM:1.6K OHM,5%,0.25M | 19701 | 5043CX1K600J |
| A17R1518 | 315-0562-00 | | | RES,FXD,FILM:5.6K OHM,5%,0.25M | 57668 | NTR25J-E05K6 |
| A17R1519 | 315-0162-00 | | | RES,FXD,FILM:1.6K OHM,5%,0.25M | 19701 | 5043CX1K600J |
| A17R1521 | 307-0839-00 | | | RES,FXD,FILM:200K OHM,1%,3M,TC=250PPM/DEG C | 07716 | GS3 200K OHM+-1% |
| A17R1611 | 315-0202-00 | | | RES,FXD,FILM:2K OHM,5%,0.25M | 57668 | NTR25J-E 2K |
| A17R1615 | 308-0642-00 | | | RES,FXD,MM:40.0 OHM,0.5%,0.5M | 91637 | RS12840R000 |
| A17R1621 | 315-0103-00 | | | RES,FXD,FILM:10K OHM,5%,0.25M | 19701 | 5043CX10K00J |
| A17R1626 | 315-0105-00 | | | RES,FXD,FILM:1M OHM,5%,0.25M | 19701 | 5043CX1M000J |
| A17R1637 | 308-0788-00 | | | RES,FXD,MM:20 OHM,5%,1M | 75042 | BM-20F-20R00J |
| A17S1731 | 260-1518-00 | | | SWITCH,SENS:DPDT,5A,125VAC,MOMENTARY | 01963 | E61-00A |
| A17U1110 | 156-1149-01 | | | MICROCKT,LINER:OPERATION AMP JFET INPUT | 27014 | AL160307 |
| A17U1120 | 156-1156-00 | | | MICROCKT,LINER:OPERATIONAL AMPLIFIER | 27014 | LF356N |
| A17U1210 | 156-1492-01 | | | MICROCKT,LINER:OPERATIONAL AMPLIFIER,SCRN (EARLY INSTRUMENTS MAY USE SELECTED 156-0921-01.PARTS ARE INTERCHANGEABLE.) | 24355 | AD40764 |
| A17U1230 | 156-1306-00 | | | MICROCKT,LINER:TTL,4.5 DIGIT A/D CONVERTER | 17856 | SLD2004 |
| A17U1300 | 156-0796-01 | | | MICROCKT,DGTL:8 STG SHF & STORE BUS RGTR | 02735 | CD40948FX |
| A17U1400 | 156-0350-01 | 8010100 | 8021903 | MICROCKT,DGTL:CMOS,QUAD 2-INPUT NAND GATE | 80009 | 156-0350-01 |
| A17U1400 | 156-0350-05 | 8021904 | | MICROCKT,DGTL:QUAD 2 INPUT NAND GATE | 02735 | CD4011BFX |
| A17U1500 | 156-0796-01 | | | MICROCKT,DGTL:8 STG SHF & STORE BUS RGTR | 02735 | CD40948FX |

Replaceable Electrical Parts - DM 5010

| Component No. | Tektronix Part No. | Serial/Assembly No. Effective | Dscont | Name & Description | Mfr. Code | Mfr. Part No. |
|---------------|--------------------|-------------------------------|---------|--|-----------|---------------|
| A17U1601 | 156-1160-00 | | | MICROCKT, LINEAR:VOLTAGE REGULATOR | 04713 | MC78L12ACG |
| A17U1603 | 156-0991-00 | | | MICROCKT, LINEAR:VOLTAGE REGULATOR | 04713 | MC78L05ACP |
| A17U1605 | 156-1207-00 | | | MICROCKT, LINEAR:VOLTAGE REGULATOR, -12 V | 04713 | MC79L12ACG |
| A17VR1001 | 152-0278-00 | | | SEMICON DVC, DI:ZEN, SI, 3V, 5%, 0.4M, 00-7 | 04713 | SZG35009K20 |
| A17VR1011 | 152-0227-00 | | | SEMICON DVC, DI:ZEN, SI, 6.2V, 5%, 0.4M, 00-7 | 04713 | SZ13903 |
| A17VR1013 | 152-0278-00 | | | SEMICON DVC, DI:ZEN, SI, 3V, 5%, 0.4M, 00-7 | 04713 | SZG35009K20 |
| A17VR1015 | 152-0227-00 | | | SEMICON DVC, DI:ZEN, SI, 6.2V, 5%, 0.4M, 00-7 | 04713 | SZ13903 |
| A17VR1124 | 152-0278-00 | | | SEMICON DVC, DI:ZEN, SI, 3V, 5%, 0.4M, 00-7 | 04713 | SZG35009K20 |
| A17VR1126 | 152-0278-00 | | | SEMICON DVC, DI:ZEN, SI, 3V, 5%, 0.4M, 00-7 | 04713 | SZG35009K20 |
| A17VR1129 | 152-0217-00 | | | SEMICON DVC, DI:ZEN, SI, 8.2V, 5%, 0.4M, 00-7 | 04713 | SZG20 |
| A17VR1223 | 152-0778-00 | | | SEMICON DVC, DI:ZEN, SI, 22V, 2%, 0.4M, 00-35 | 04713 | SZG30337RL |
| A17VR1225 | 152-0778-00 | | | SEMICON DVC, DI:ZEN, SI, 22V, 2%, 0.4M, 00-35 | 04713 | SZG30337RL |
| A17VR1321 | 152-0526-00 | | | SEMICON DVC, DI:ZEN, SI, 6.35V, 1%, 0.4M, 00-7 | 14552 | DT840615A |
| A17VR1501 | 152-0195-00 | | | SEMICON DVC, DI:ZEN, SI, 5.1V, 5%, 0.4M, 00-7 | 04713 | SZ11755RL |
| A17VR1514 | 152-0777-00 | | | SEMICON DVC, DI:ZEN, SI, 27V, 2%, 0.4M, 00-35 | 04713 | SZG30343RL |
| A17M1613 | 131-0566-00 | | | BUS, COND:DUMMY RES, 0.094 00 X 0.225L | 24546 | OWA 07 |
| A17A1 | 670-6945-00 | B010100 | B021903 | CIRCUIT BD ASSY:RELAY | 80009 | 670-6945-00 |
| A17A1 | 670-6945-01 | B021904 | | CIRCUIT BD ASSY:RELAY (NO ELECTRICAL PARTS) | 80009 | 670-6945-01 |

DIAGRAMS AND CIRCUIT BOARD ILLUSTRATIONS

Symbols

Graphic symbols and class designation letters are based on ANSI Standard Y32.2-1975.

Logic symbology is based on ANSI Y32.14-1973 in terms of positive logic. Logic symbols depict the logic function performed and may differ from the manufacturer's data.

The overline on a signal name indicates that the signal performs its intended function when it is in the low state.

Abbreviations are based on ANSI Y1.1-1972.

Other ANSI standards that are used in the preparation of diagrams by Tektronix, Inc. are:

- Y14.15, 1966 Drafting Practices.
- Y14.2, 1973 Line Conventions and Lettering.
- Y10.5, 1968 Letter Symbols for Quantities Used in Electrical Science and Electrical Engineering.

American National Standard Institute
1430 Broadway
New York, New York 10018

Component Values

Electrical components shown on the diagrams are in the following units unless noted otherwise:

Capacitors = Values one or greater are in picofarads (pF).
Values less than one are in microfarads (μF).

Resistors = Ohms (Ω).

————— The information and special symbols below may appear in this manual. —————

Assembly Numbers and Grid Coordinates

Each assembly in the instrument is assigned an assembly number (e.g., A20). The assembly number appears on the circuit board outline on the diagram, in the title for the circuit board component location illustration, and in the lookup table for the schematic diagram and corresponding component locator illustration. The Replaceable Electrical Parts list is arranged by assemblies in numerical sequence; the components are listed by component number *(see following illustration for constructing a component number).

The schematic diagram and circuit board component location illustration have grids. A lookup table with the grid coordinates is provided for ease of locating the component. Only the components illustrated on the facing diagram are listed in the lookup table. When more than one schematic diagram is used to illustrate the circuitry on a circuit board, the circuit board illustration may only appear opposite the first diagram on which it was illustrated; the lookup table will list the diagram number of other diagrams that the circuitry of the circuit board appears on.

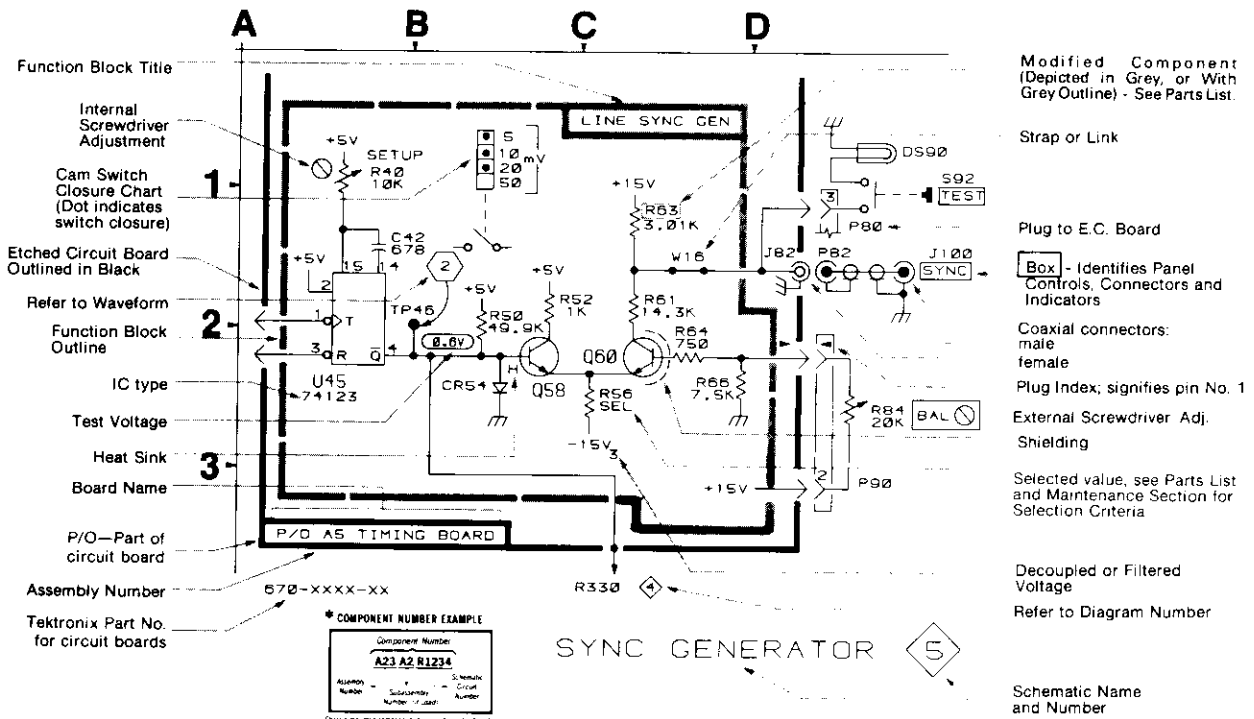

REV DEC 1981

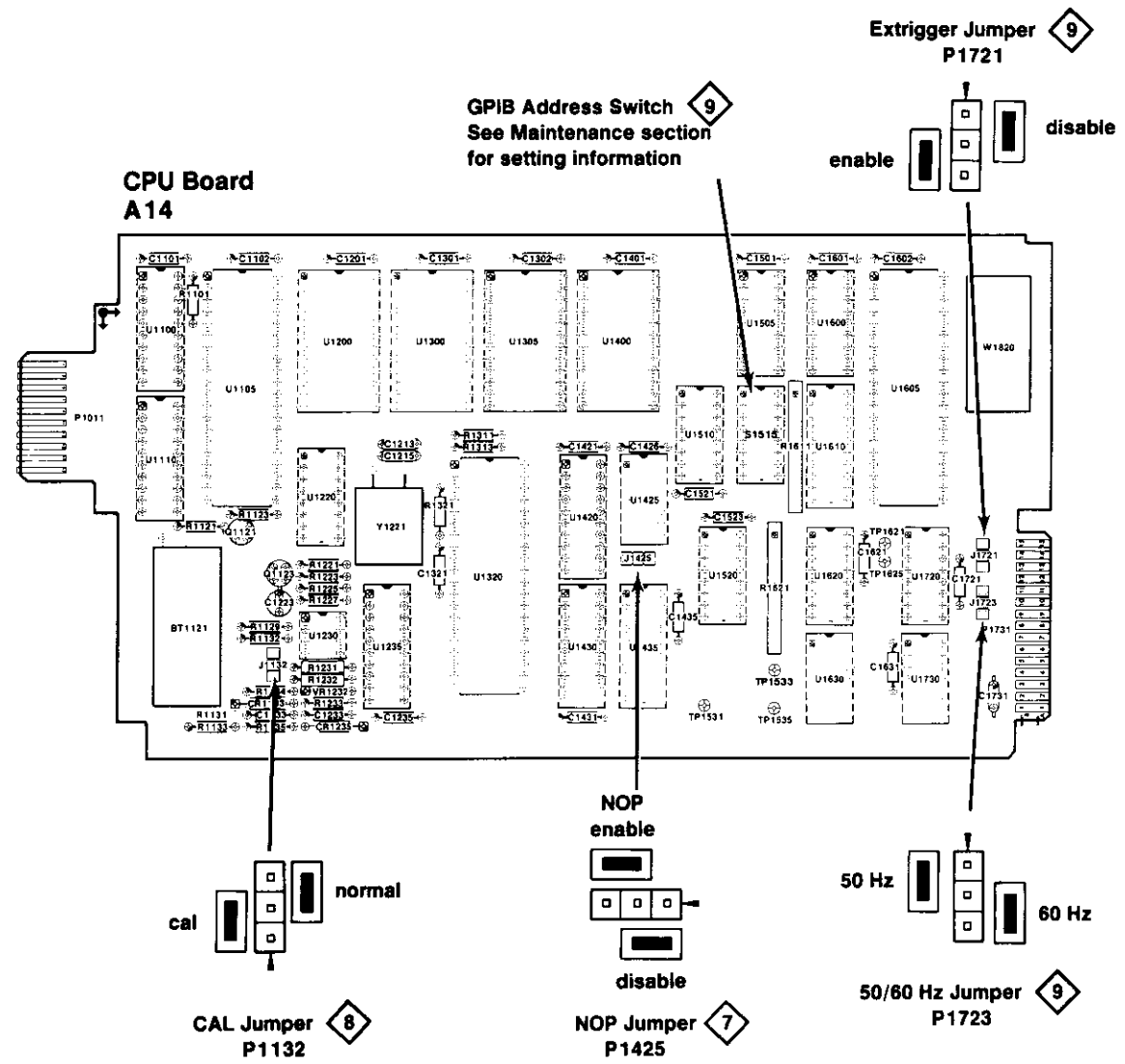

2994-53

Fig. 10-1 Jumper and GPIB address switch locations.

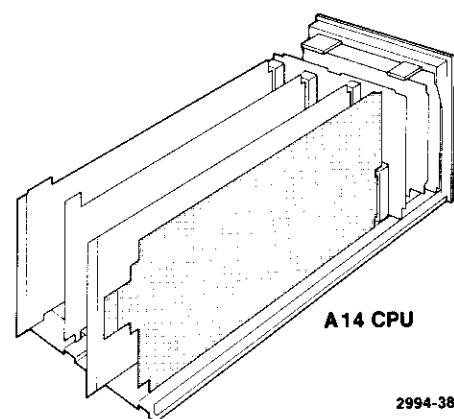

A14 CPU
2994-38

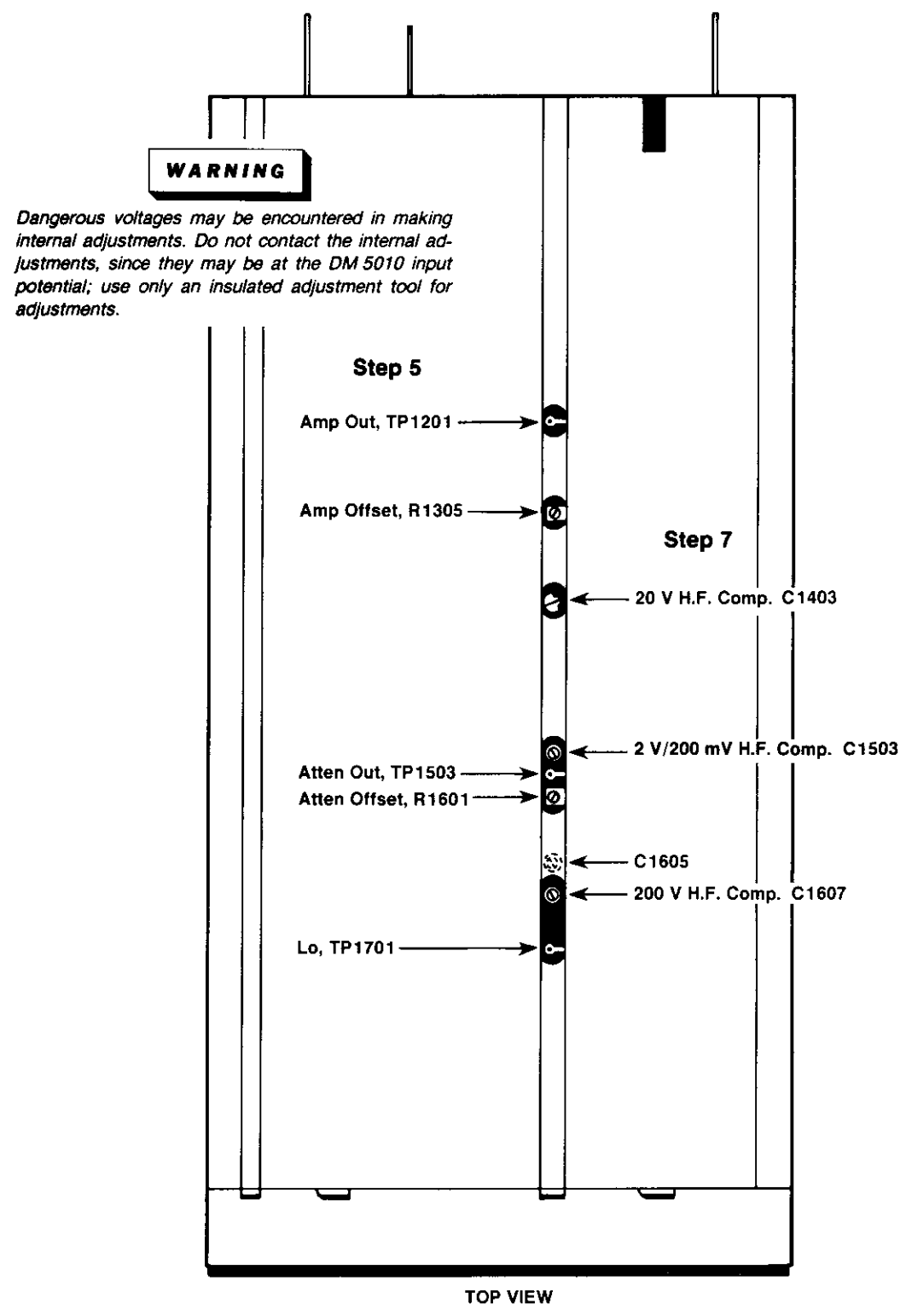

AND ADJUSTMENTS

TOP VIEW

2994-37

Fig. 10-2. Location of DM 5010 adjustments and test points. 3

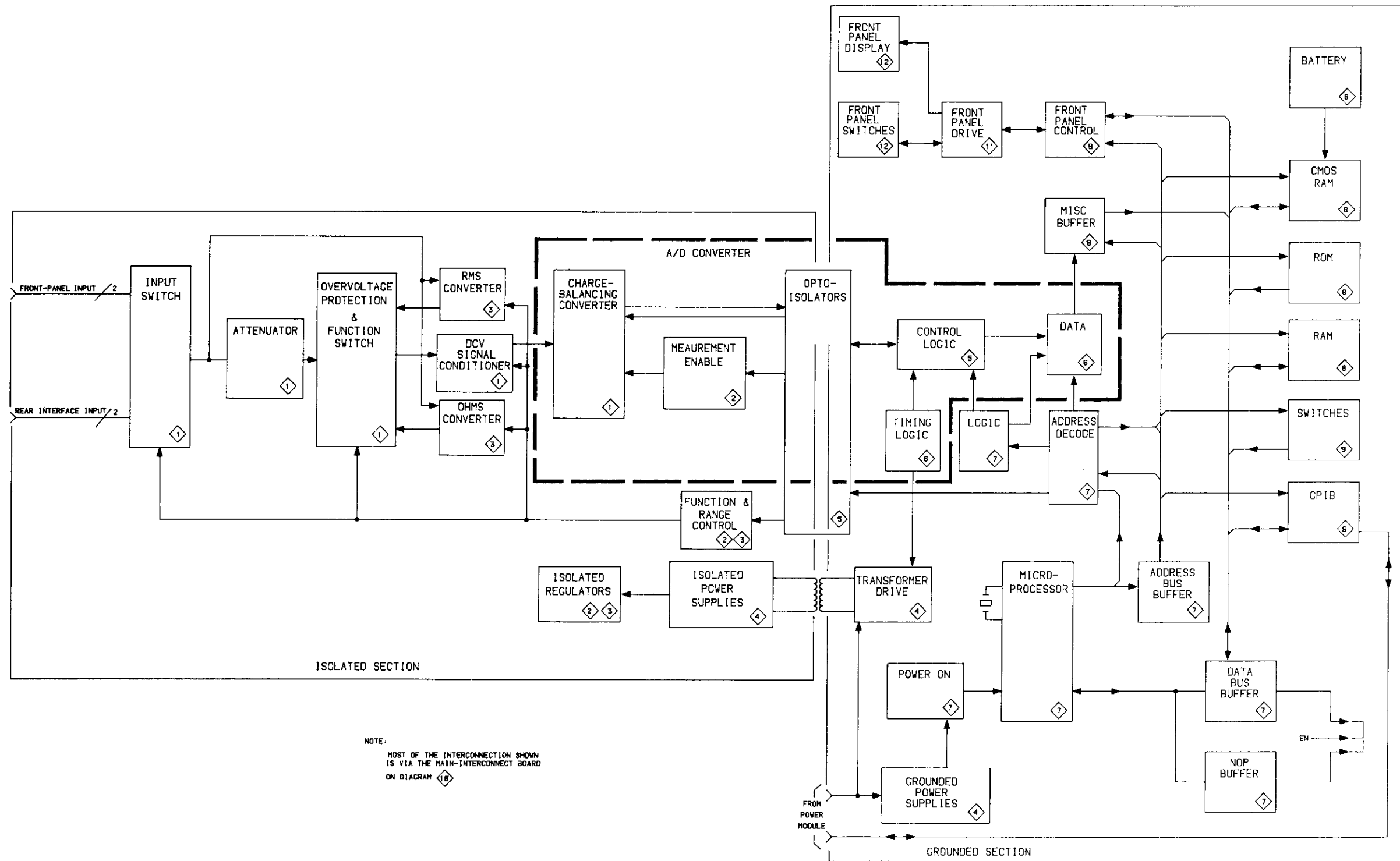

Table 10-1 COMPONENT REFERENCE CHART

| P/O A17 ASSY | | | ADC BOARD 1 | | |
|----------------|--------------------|----------------|---|--------------------|----------------|
| CIRCUIT NUMBER | SCHEMATIC LOCATION | BOARD LOCATION | CIRCUIT NUMBER | SCHEMATIC LOCATION | BOARD LOCATION |
| C1001 | B6 | B2 | R1001 | C7 | B2 |
| C1013 | C9 | B3 | R1011 | B8 | B2 |
| C1017 | D7 | B3 | R1013 | C9 | B2 |
| C1019 | D8 | B3 | R1033 | I9 | C5 |
| C1021* | J6 | B4 | R1101 | G7 | D1 |
| C1031* | J7 | B5 | R1102 | G7 | D2 |
| C1123 | J6 | C4 | R1103 | G6 | D2 |
| C1126 | C6 | D4 | R1104 | G6 | D2 |
| C1128 | J9 | C5 | R1115 | E5 | D2 |
| C1131 | J7 | C5 | R1116 | F8 | D2 |
| C1133* | J9 | C5 | R1117 | D7 | D2 |
| C1135* | I9 | D5 | R1120* | H6 | |
| C1137 | J9 | C5 | R1121 | H7 | C4 |
| C1139 | J7 | D6 | R1122 | D9 | D4 |
| C1221 | C6 | D4 | R1124 | D6 | D4 |
| C1225 | K6 | E4 | R1125 | I7 | C5 |
| C1323 | K8 | F5 | R1126 | I6 | C4 |
| C1331 | J8 | F5 | R1129 | L6 | D5 |
| C1723 | C3 | L5 | R1139 | J7 | C5 |
| | | | R1212 | H8 | E2 |
| | | | R1213 | H8 | E3 |
| | | | R1214 | H8 | E3 |
| | | | R1215 | L3 | E3 |
| | | | R1222 | C5 | E3 |
| | | | R1223 | I3 | D4 |
| | | | R1225 | J4 | D4 |
| | | | R1227 | K6 | E5 |
| | | | R1228 | J7 | E5 |
| | | | R1229 | J6 | E5 |
| | | | R1231 | K6 | E5 |
| | | | R1233 | J7 | E5 |
| | | | R1301 | L5 | F2 |
| | | | R1315 | K3 | E3 |
| | | | R1316 | K5 | F3 |
| | | | R1321 | J7 | F5 |
| | | | R1323 | J7 | F5 |
| | | | R1331 | L7 | F5 |
| | | | R1415 | J4 | G3 |
| | | | R1416 | J4 | G3 |
| | | | R1418 | K5 | G3 |
| | | | R1419 | G5 | G3 |
| | | | R1427 | G3 | G4 |
| | | | R1429 | G4 | H4 |
| | | | R1517 | E4 | H3 |
| | | | R1519 | F2 | H3 |
| | | | R1521 | G3 | G5 |
| | | | R1615 | C1 | J3 |
| | | | R1626 | E3 | L3 |
| | | | R1637 | E2 | J5 |
| | | | S1731 | B3 | N5 |
| | | | U1110 | D8 | C3 |
| | | | U1120 | J7 | C5 |
| | | | U1210 | D5 | D2 |
| | | | U1230 | L7 | E5 |
| | | | VR1001 | B7 | B2 |
| | | | VR1011 | C8 | B2 |
| | | | VR1013 | B9 | B3 |
| | | | VR1015 | C8 | B3 |
| | | | VR1124 | I7 | C4 |
| | | | VR1126 | I6 | C4 |
| | | | VR1129 | L6 | D5 |
| | | | VR1223 | I4 | E4 |
| | | | VR1225 | J3 | E4 |
| | | | VR1321 | J8 | F5 |
| | | | W1613 | C1 | J3 |

P/O A17 ASSY also shown on 2

*See Parts List for serial number ranges.

PARTS LOCATION GRID

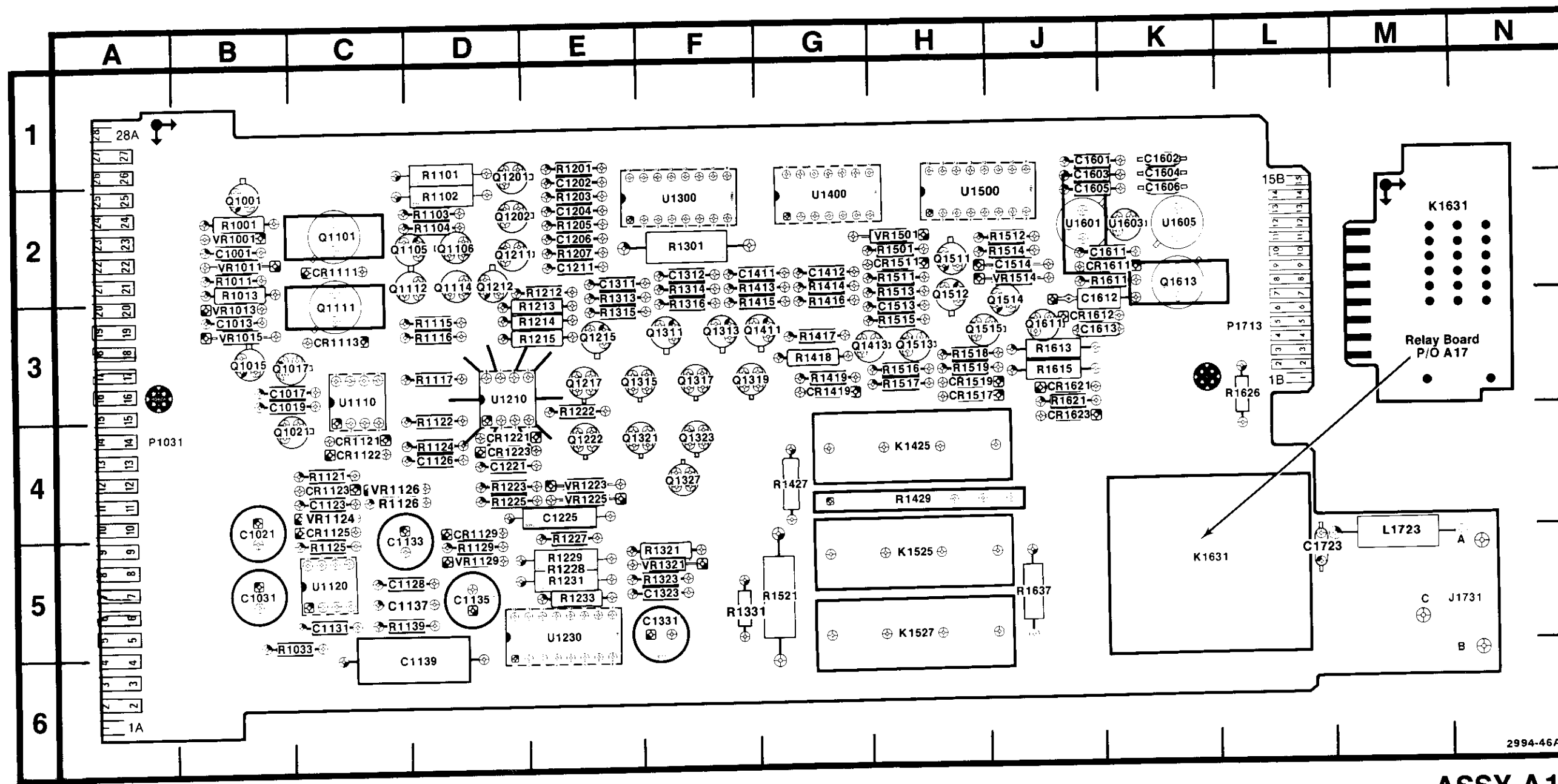
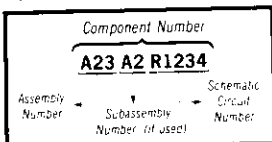

Fig. 10-3. ADC Board (A17)

ASSY A17

⊗ Static Sensitive Devices
See Maintenance Section

COMPONENT NUMBER EXAMPLE



Chassis-mounted components have no Assembly Number prefix—see end of Replaceable Electrical Parts List

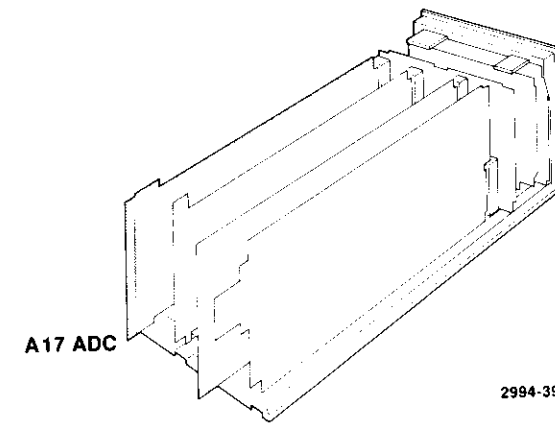

REV JULY 1986

2994-39

Table 10-2
INPUT & ATTENUATION SWITCHING

| | | MODE AND RANGE | | | | | | | | | | | | | | | | | | | | COMMENTS |
|--------------------------------------|---|----------------|----------|-------------------------------|------|-------|------|-------|--------|-----|--------|-----|--------|------|--------|-------|--------|-------|--------|-------|------------|--|
| | | REAR INPUT | INPUT X1 | RMS TERMINATION INPUT = 10 | 1 kV | 200 V | 20 V | 200 V | 700 mV | 2 V | 200 mV | 2 V | 200 mV | 20 V | 200 mV | 20 mV | 200 mV | 20 mV | 200 mV | 20 mV | OHMS TOTAL | |
| Switches, Transistors Actuated | | | | | | | | | | | | | | | | | | | | | | |
| Rear Input Switch | X | | | | | | | | | | | | | | | | | | | | | |
| Input Attenuation Switches | | | | | | | | | | | | | | | | | | | | | | |
| K1527 | X | | | | | | | | | | | | | | | | | | | | | |
| K1525 | | X | | | | | | | | | | | | | | | | | | | | |
| K1425 | | X | X | | | | | | | | | | | | | | | | | | | |
| Function Switches | | | | | | | | | | | | | | | | | | | | | | |
| Q1317 | | | | | | | | | | | | | | | | | | | | | | Provides input attenuation of 1 |
| Q1217 | | | | | | | | | | | | | | | | | | | | | | Used only with K1425 to provide -10 |
| Q1315 | | | | | | | | | | | | | | | | | | | | | | Provides RMS termination when used alone |
| Q1319 | | | | | | | | | | | | | | | | | | | | | | |
| DCV Gain Switches | | | | | | | | | | | | | | | | | | | | | | |
| Q1105 | | | | | | | | | | | | | | | | | | | | | | On when zeroing A/D converter |
| Q1106 | | | | | | | | | | | | | | | | | | | | | | On when using RMS converter |
| Q1112 | | | | | | | | | | | | | | | | | | | | | | On when measuring Ohms total |
| Q1114 | | | | | | | | | | | | | | | | | | | | | | On when measuring an external voltage |
| | | | | | | | | | | | | | | | | | | | | | | Gain of the DCV Converter |
| | | | | | | | | | | | | | | | | | | | | | | 10 |
| | | | | | | | | | | | | | | | | | | | | | | 0.1 |
| | | | | | | | | | | | | | | | | | | | | | | X |
| | | | | | | | | | | | | | | | | | | | | | | |
| | | | | | | | | | | | | | | | | | | | | | | X |
| | | | | | | | | | | | | | | | | | | | | | | |
| | | | | | | | | | | | | | | | | | | | | | | X |
| | | | | | | | | | | | | | | | | | | | | | | X |

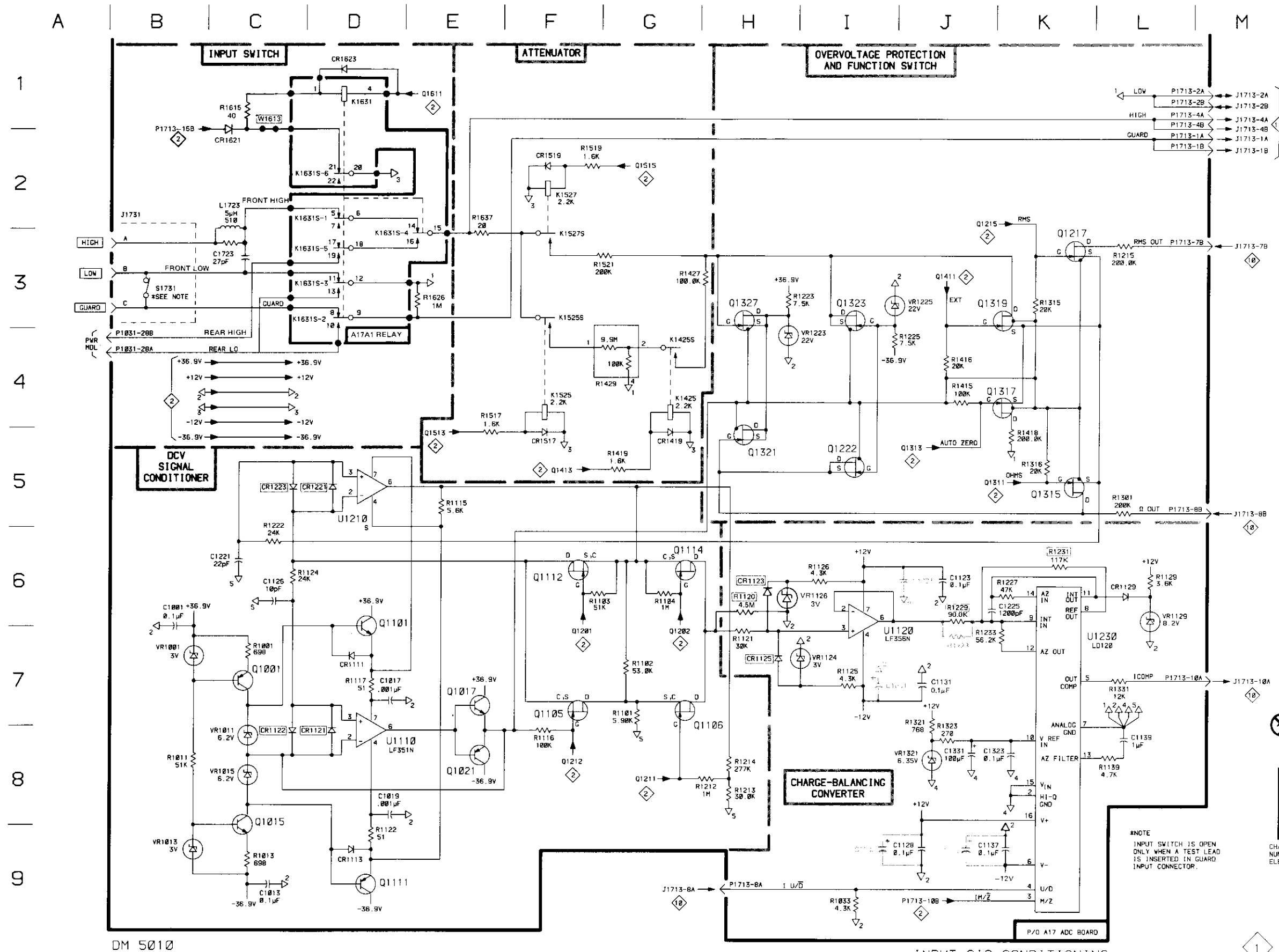

SEE PARTS LIST FOR PARTS VALUES AND SPECIAL NOTES. RANGES OF PARTS (U/P/N'S) OR LETTERS A-Z ONLY.

⚡ STATIC SENSITIVE DEVICES
SEE MAINTENANCE SECTION

COMPONENT NUMBER EXAMPLE

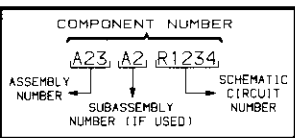



CHASSIS-MOUNTED COMPONENTS HAVE NO ASSEMBLY NUMBER PREFIX—SEE END OF REPLACEABLE ELECTRICAL PARTS LIST

*NOTE
INPUT SWITCH IS OPEN ONLY WHEN A TEST LEAD IS INSERTED IN GUARD INPUT CONNECTOR.

INPUT & ATTEN SWITCHING

Table 10-3
COMPONENT REFERENCE CHART
(See Fig. 10-3)

| P/O A17 ASSY | | | ADC BOARD  | | |
|----------------|--------------------|----------------|---|--------------------|----------------|
| CIRCUIT NUMBER | SCHEMATIC LOCATION | BOARD LOCATION | CIRCUIT NUMBER | SCHEMATIC LOCATION | BOARD LOCATION |
| C1202 | J6 | E1 | Q1513 | J7 | H3 |
| C1204 | J5 | E2 | Q1514 | E3 | J3 |
| C1206 | J4 | E2 | Q1515 | J8 | J3 |
| C1211 | J5 | E2 | Q1611 | J7 | J3 |
| C1311 | J2 | E2 | Q1613 | D6 | K2 |
| C1312 | J4 | F2 | | | |
| C1411 | J3 | G2 | R1201 | J7 | E1 |
| C1412 | J2 | G2 | R1203 | J6 | E2 |
| C1513 | G5 | H3 | R1205 | J5 | E2 |
| C1514 | E3 | J2 | R1207 | J5 | E2 |
| C1601 | D3 | J1 | R1313 | J2 | E2 |
| C1602 | B3 | K1 | R1314 | J4 | F2 |
| C1603 | D4 | J1 | R1413 | J3 | G2 |
| C1604 | B4 | K1 | R1414 | J3 | G2 |
| C1605 | D5 | J2 | R1417 | J8 | G3 |
| C1606 | B5 | K2 | R1501 | F1 | H2 |
| C1611 | D6 | K2 | R1511 | E1 | H2 |
| C1612 | C6 | J3 | R1512 | E1 | J2 |
| C1613 | C5 | J3 | R1513 | G2 | H2 |
| | | | R1514 | E3 | J2 |
| CR1511 | F2 | H2 | R1515 | F2 | H3 |
| CR1611 | B6 | K2 | R1516 | J7 | H3 |
| CR1612 | C6 | J3 | R1518 | J8 | H3 |
| | | | R1611 | C6 | K2 |
| Q1201 | J6 | D1 | R1621 | J7 | J3 |
| Q1202 | J6 | D2 | | | |
| Q1211 | J5 | D2 | U1300 | H5 | F2 |
| Q1212 | J5 | D2 | U1400* | I2 | G2 |
| Q1215 | J2 | E3 | U1500 | F6 | H2 |
| Q1311 | J4 | F3 | U1601 | C2 | J2 |
| Q1313 | J3 | F3 | U1603 | C4 | K2 |
| Q1411 | J3 | G3 | U1605 | C4 | K2 |
| Q1413 | J8 | H3 | | | |
| Q1511 | F2 | H2 | VR1501 | E1 | H2 |
| Q1512 | G2 | H2 | VR1514 | B5 | J2 |

P/O A17 ASSY also shown on 

*See Parts List for serial number ranges.

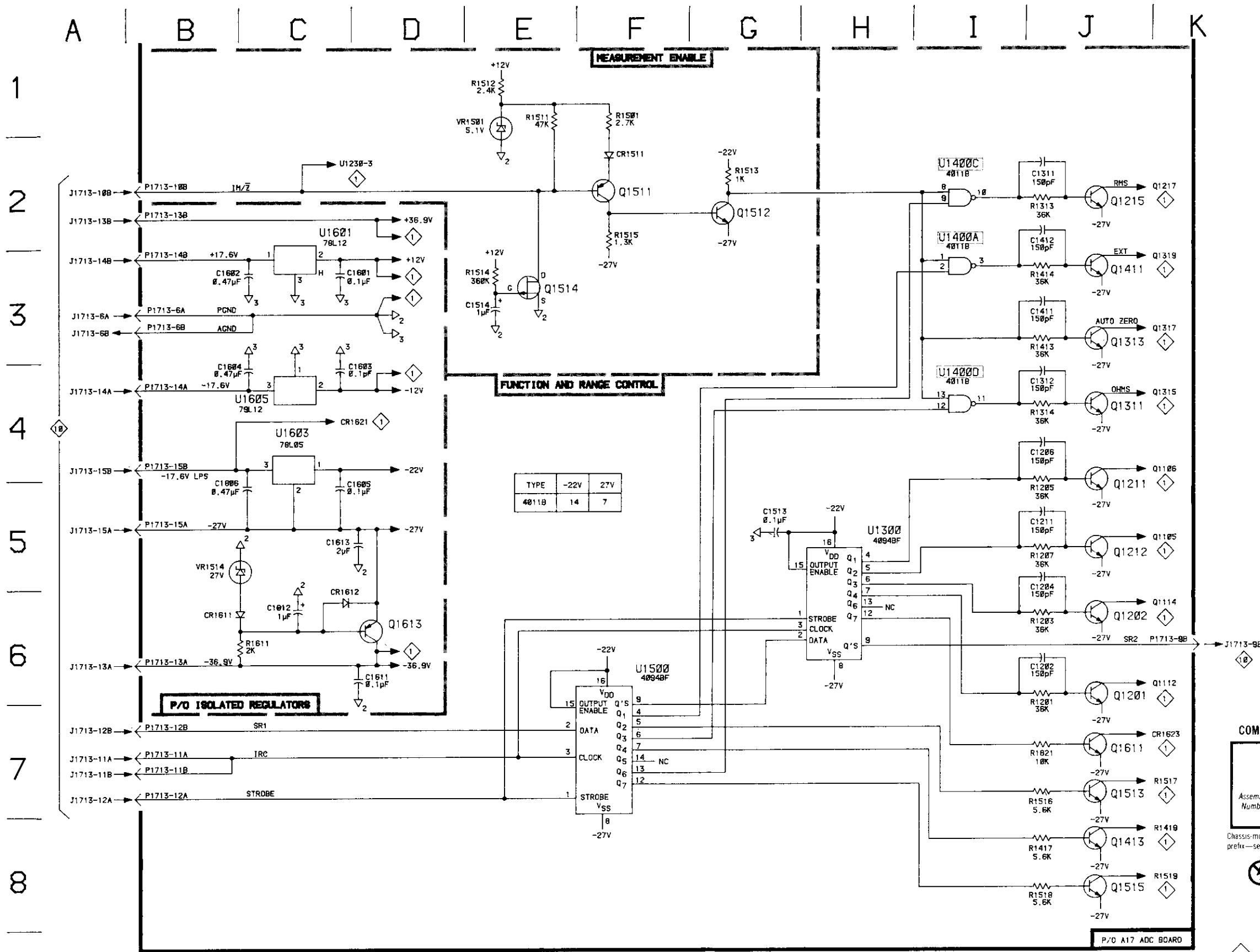

COMPONENT NUMBER EXAMPLE

Component Number
A23 A2 R1234

Assembly Number Subassembly Number (if used) Schematic Circuit Number

Chassis-mounted components have no Assembly Number prefix—see end of Replaceable Electrical Parts List.

Static Sensitive Devices
See Maintenance Section

Table 10-4 COMPONENT REFERENCE CHART

| A16 ASSY | | | RMS BOARD 3 | | |
|----------------|--------------------|----------------|---|--------------------|----------------|
| CIRCUIT NUMBER | SCHEMATIC LOCATION | BOARD LOCATION | CIRCUIT NUMBER | SCHEMATIC LOCATION | BOARD LOCATION |
| C1001 | I9 | B2 | R1003 | K7 | B2 |
| C1013 | I2 | B3 | R1013 | I3 | B3 |
| C1101 | J7 | B2 | R1021 | H1 | B3 |
| C1103 | I6 | C2 | R1031 | K3 | B5 |
| C1105 | J6 | C2 | R1032 | L6 | B5 |
| C1107 | J8 | D2 | R1033 | K3 | B5 |
| C1111 | G3 | C3 | R1101 | I9 | C2 |
| C1113 | I2 | C3 | R1121 | H3 | C3 |
| C1301 | F8 | E2 | R1123 | G2 | C3 |
| C1303 | F9 | E2 | R1201 | H7 | D2 |
| C1311 | G9 | F3 | R1211 | H8 | D2 |
| C1403 | G8 | F2 | R1221 | G2 | D3 |
| C1405 | G8 | F2 | R1223 | G1 | D3 |
| C1415 | E1 | G3 | R1225 | H1 | D3 |
| C1417 | C-1 | G3 | R1229 | I1 | E3 |
| C1503 | F7 | H2 | R1231 | L5 | E5 |
| C1505 | F7 | H2 | R1233 | L6 | E5 |
| C1513 | D3 | H3 | R1303 | H7 | E2 |
| C1515 | C3 | H3 | R1305 | H7 | F2 |
| C1525 | C3 | H4 | R1307 | G7 | F2 |
| C1526 | D3 | H4 | R1309 | G9 | F2 |
| C1527 | C2 | H4 | R1321 | I1 | E3 |
| C1528 | D2 | H4 | R1323 | D2 | E3 |
| C1601 | E8 | J2 | R1325 | K5 | F4 |
| C1603 | E9 | J2 | R1327 | K6 | F4 |
| C1605 | D9 | J2 | R1331 | K3 | E5 |
| C1607 | D8 | K2 | R1333 | J2 | E5 |
| C1609 | D8 | K2 | R1401 | G7 | F2 |
| C1621 | C7 | J5 | R1403 | G7 | F2 |
| CR1011 | J3 | B3 | R1415 | D1 | G3 |
| CR1021 | H2 | B3 | R1421 | K6 | F4 |
| CR1023 | L5 | B4 | R1423 | K5 | F4 |
| CR1121* | H2 | C3 | R1425 | K8 | G4 |
| CR1201 | L8 | D2 | R1426 | K8 | G4 |
| CR1225 | J2 | D3 | R1427 | K7 | G4 |
| CR1227 | I2 | D3 | R1429 | K9 | G4 |
| CR1231 | L4 | E4 | R1501 | E7 | G2 |
| CR1233 | L6 | E4 | R1521 | K9 | G4 |
| CR1415 | L5 | G3 | R1523 | L9 | H4 |
| CR1511 | L7 | G3 | R1525 | L9 | H4 |
| CR1513 | L7 | H3 | R1601 | E7 | J2 |
| CR1527 | L9 | H4 | R1603 | D7 | J2 |
| CR1529 | L8 | H4 | R1609 | C8 | K2 |
| CR1613 | D7 | J3 | R1621 | C7 | K4 |
| CR1615 | D7 | K3 | R1633 | B7 | K6 |
| K1031 | L6 | B5 | RT1011 | J3 | A3 |
| K1031 | K3 | B5 | RT1227 | I2 | D3 |
| K1131 | L3 | C5 | TP1201 | I7 | E2 |
| K1131 | L6 | C5 | TP1503 | F7 | H2 |
| K1201 | H8 | D2 | TP1701 | D7 | K1 |
| K1201 | L8 | D2 | U1100 | J7 | C2 |
| K1231 | J4 | D5 | U1120 | H2 | C4 |
| K1231 | L5 | D5 | U1200 | H7 | E2 |
| K1313 | G1 | F3 | U1200 | E9 | E2 |
| K1313 | L5 | F3 | U1330 | I4 | F5 |
| K1405 | L8 | G2 | U1417 | D1 | G3 |
| K1503 | F7 | H2 | U1430 | G4 | G5 |
| K1503 | L7 | H2 | U1500 | D9 | H2 |
| K1621 | L9 | K4 | U1500 | E7 | H2 |
| K1621 | C8 | K4 | U1515 | C3 | H3 |
| K1633 | L9 | K5 | U1525 | D3 | H4 |
| K1633 | C7 | K5 | U1527 | D2 | H4 |
| P1711 | B7 | L3 | U1530 | E8 | H5 |
| Q1021 | I3 | B4 | U1530 | F5 | H5 |
| Q1320 | L4 | F4 | VR1013 | I3 | B3 |
| Q1420 | L7 | G4 | VR1123 | G3 | D3 |
| | | | VR1415 | G4 | G3 |

*See Parts List for serial number ranges.

PARTS LOCATION GRID

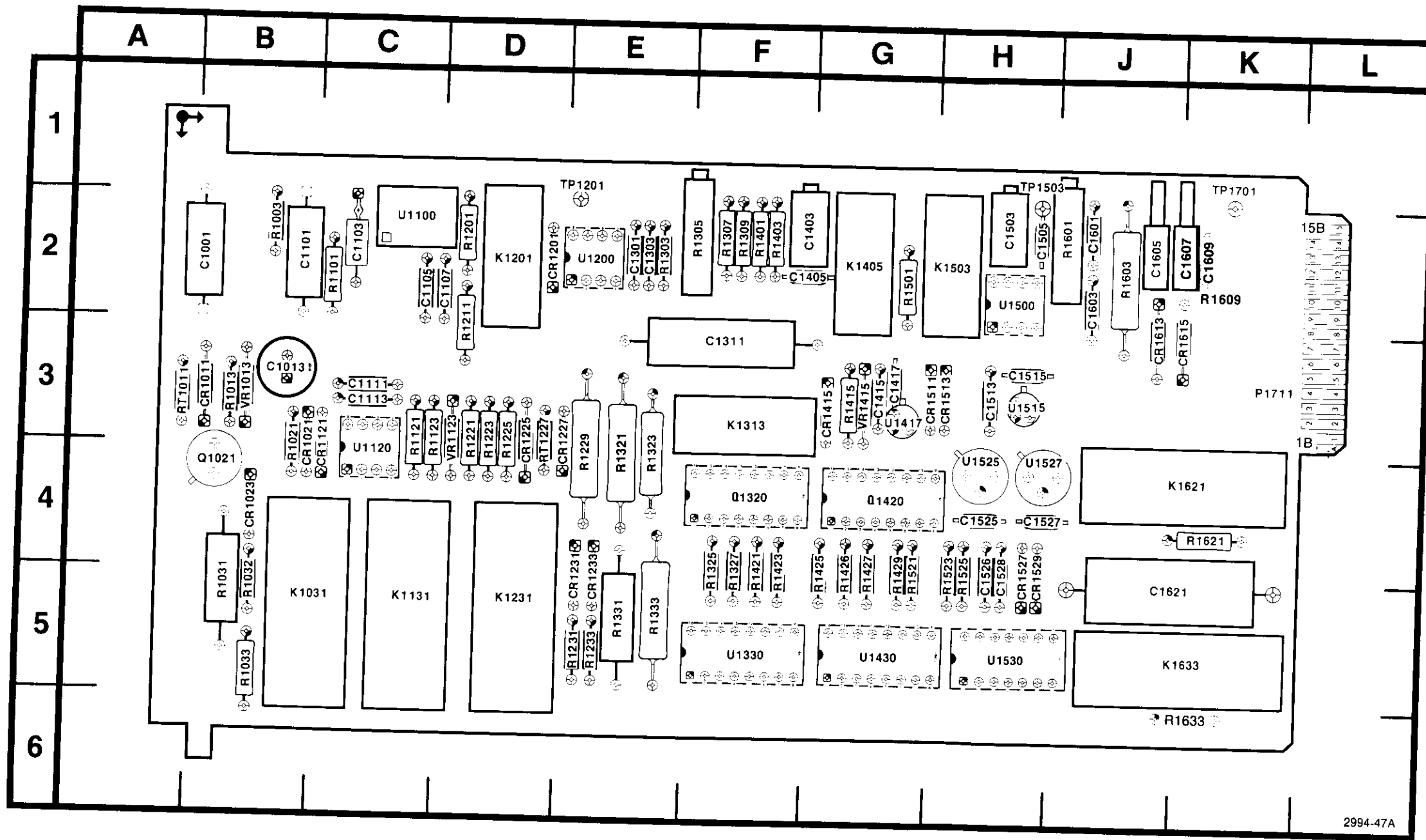
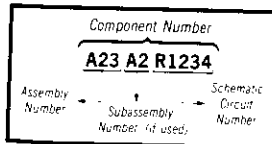

Fig. 10-4. RMS Board (A16).

ASSY A16

Static Sensitive Devices
See Maintenance Section

COMPONENT NUMBER EXAMPLE



Embossed components have no Assembly Number prefix—see end of Replaceable Electrical Parts List

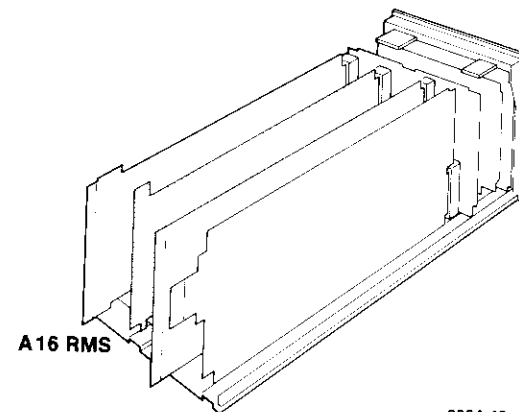

A16 RMS

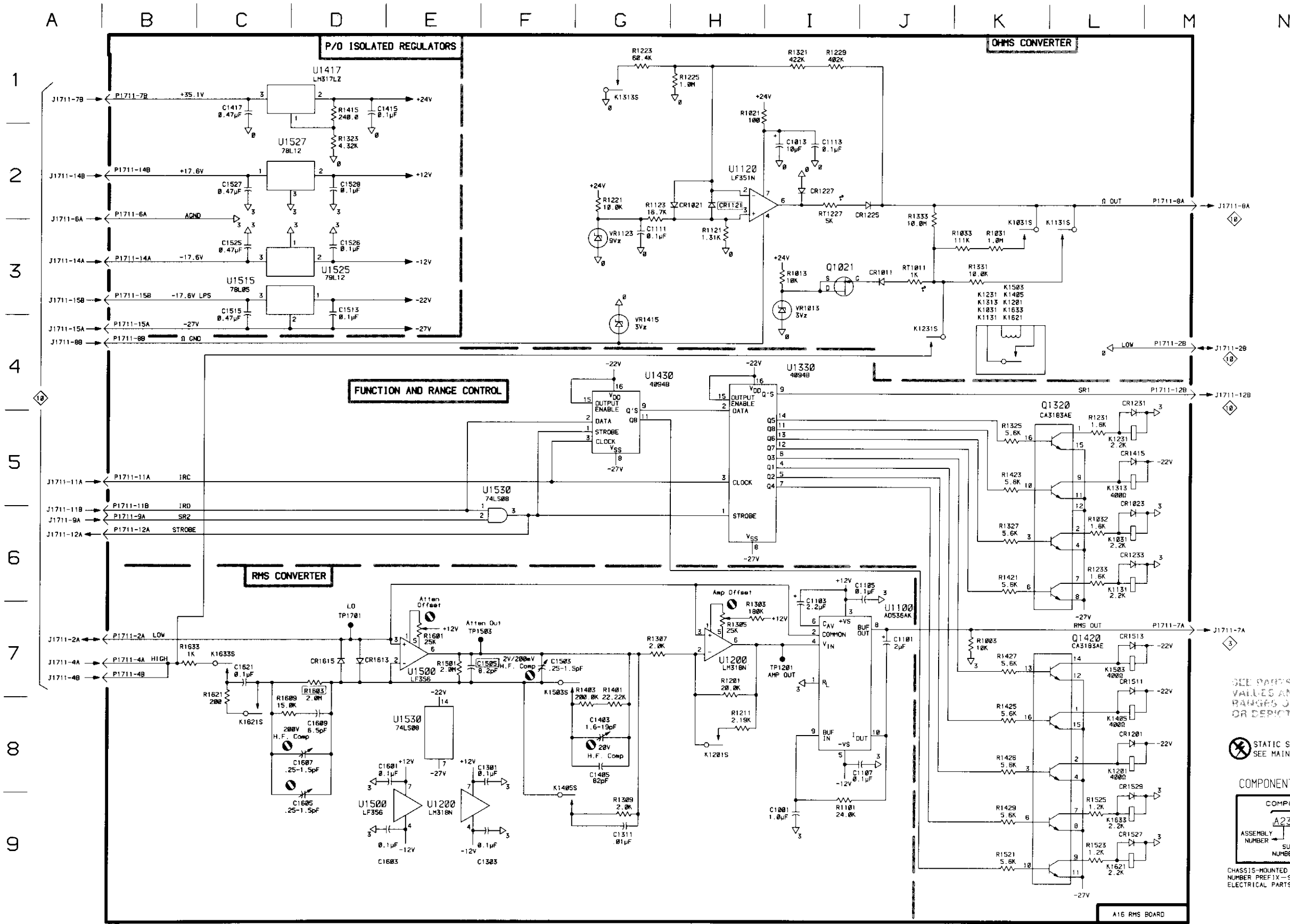

SEE PARTS LIST FOR EARLIER VALUES AND SERIAL NUMBER RANGES OR PARTS IDENTIFIED OR DELETED IN GREY

⊗ STATIC SENSITIVE DEVICES SEE MAINTENANCE SECTION

COMPONENT NUMBER EXAMPLE

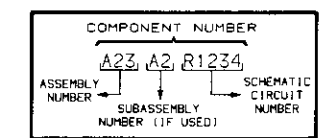

CHASSIS-MOUNTED COMPONENTS HAVE NO ASSEMBLY NUMBER PREFIX—SEE END OF REPLACEABLE ELECTRICAL PARTS LIST

6290

Table 10-6 COMPONENT REFERENCE CHART

| P/O A15 ASSY | | | ISOLATION BOARD 4 | | |
|----------------|--------------------|----------------|---|--------------------|----------------|
| CIRCUIT NUMBER | SCHEMATIC LOCATION | BOARD LOCATION | CIRCUIT NUMBER | SCHEMATIC LOCATION | BOARD LOCATION |
| C1001 | D2 | B2 | CR1509 | H5 | H2 |
| C1005 | F3 | B2 | CR1515 | H6 | G3 |
| C1021 | J3 | B5 | CR1605 | H8 | J2 |
| C1101 | E2 | C1 | | | |
| C1107 | F1 | C2 | F1111 | B1 | C3 |
| C1111 | G1 | C2 | F1113 | C7 | C3 |
| C1113 | H1 | C2 | | | |
| C1121 | J3 | C5 | L1201 | F8 | D2 |
| C1131 | J3 | C6 | L1203 | F5 | D2 |
| C1201 | F6 | D2 | | | |
| C1203 | E7 | E2 | P1031 | B1 | A6 |
| C1215 | D8 | D3 | | | |
| C1216 | D7 | E3 | Q1101 | F2 | C1 |
| C1221 | I3 | E4 | Q1104 | D2 | C2 |
| C1223 | J3 | E5 | Q1105 | C2 | C2 |
| C1301 | H9 | F1 | Q1201 | F8 | D1 |
| C1321 | J3 | E5 | Q1202 | F6 | D2 |
| C1326 | J3 | F5 | Q1211 | E8 | D3 |
| C1331 | J3 | E6 | Q1212 | E6 | E3 |
| C1401 | I9 | G2 | Q1213 | D9 | D3 |
| C1403 | H9 | G2 | Q1214 | D7 | E3 |
| C1404 | I9 | G1 | | | |
| C1421 | J3 | F5 | R1001 | D2 | B2 |
| C1426 | K3 | G5 | R1003 | D3 | B2 |
| C1501 | J6 | H1 | R1005 | F3 | B2 |
| C1502 | J7 | J2 | R1101 | E1 | C1 |
| C1503 | J6 | H1 | R1102 | E2 | C1 |
| C1504 | J7 | J2 | R1103 | D2 | C2 |
| C1505 | I7 | J1 | R1104 | C2 | C2 |
| C1511 | J6 | H2 | R1105 | F3 | D1 |
| C1513 | J6 | H3 | R1106 | F2 | D1 |
| C1515 | I6 | J2 | R1107 | E1 | C1 |
| C1521 | K3 | H5 | R1108 | B2 | C2 |
| C1526 | K3 | H5 | R1109 | B2 | C2 |
| C1601 | I7 | J1 | R1201 | F6 | E2 |
| C1603 | J8 | K1 | R1211 | E8 | D3 |
| C1611 | I6 | J2 | R1212 | E6 | E3 |
| C1621 | K3 | J5 | R1213 | D8 | D3 |
| C1626 | K3 | J5 | R1214 | D6 | E3 |
| C1701 | J8 | K1 | R1215 | D8 | D3 |
| C1721 | K3 | K5 | R1216 | D6 | E3 |
| C1731 | I3 | L6 | R1217 | E4 | D3 |
| | | | | | |
| CR1201 | F7 | D2 | T1311 | G6 | F2 |
| CR1203 | F5 | D2 | TP1421 | B4 | F3 |
| CR1211 | E8 | D2 | | | |
| CR1212 | E5 | E2 | U1000 | E2 | B1 |
| CR1501 | I5 | H2 | U1325 | C7 | F4 |
| CR1503 | H5 | H2 | | | |
| CR1505 | I5 | H2 | VR1001 | D3 | B2 |
| CR1507 | H7 | H2 | VR1216 | E4 | E3 |

P/O A15 ASSY also shown on 5 6

PARTS LOCATION GRID

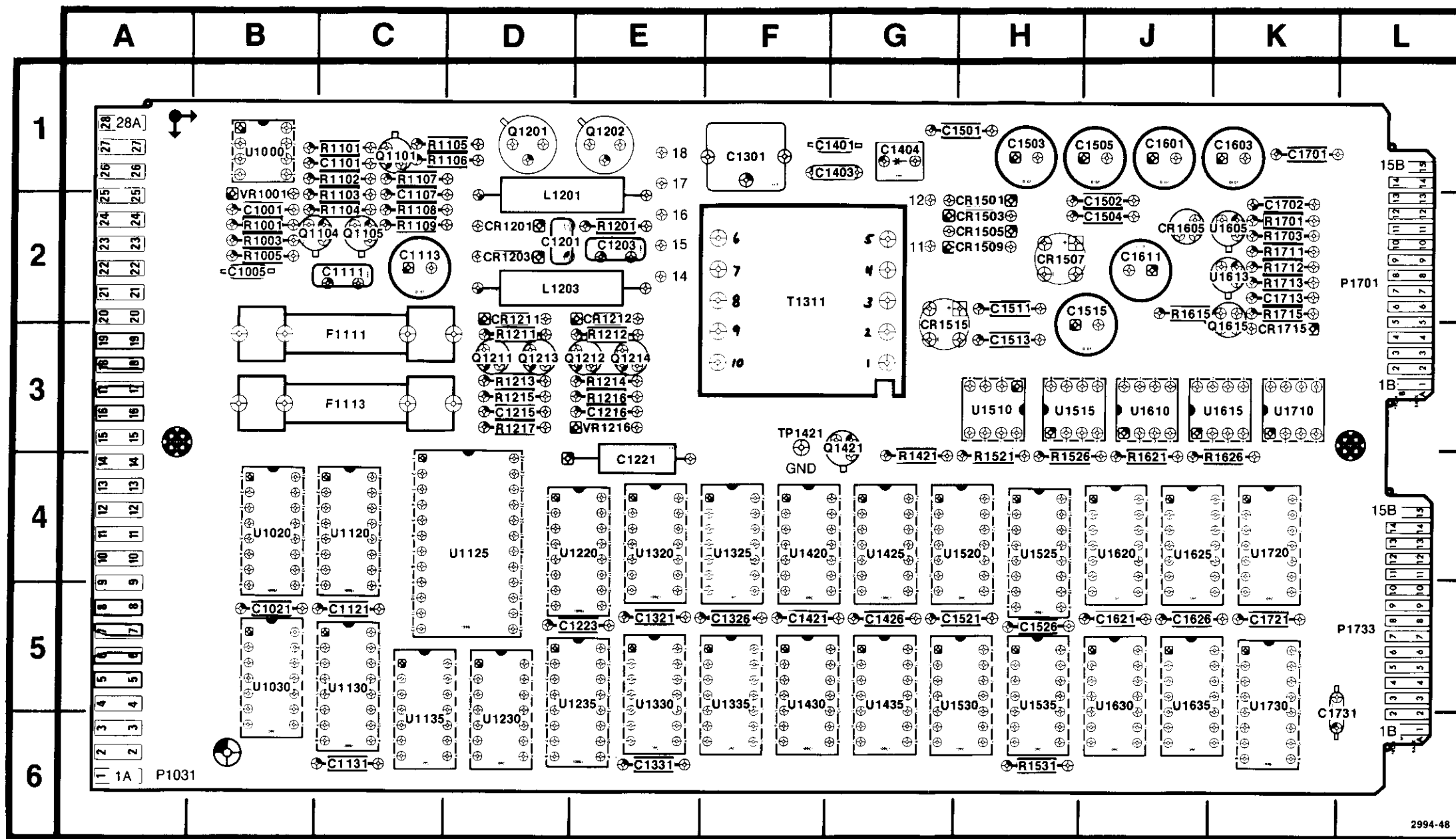
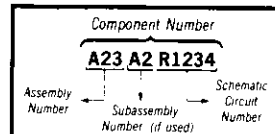

Fig. 10-5. Isolation Board (A15).

ASSY A15

⊗ Static Sensitive Devices
See Maintenance Section

COMPONENT NUMBER EXAMPLE



Chassis-mounted components have no Assembly Number prefix—see end of Replaceable Electrical Parts List

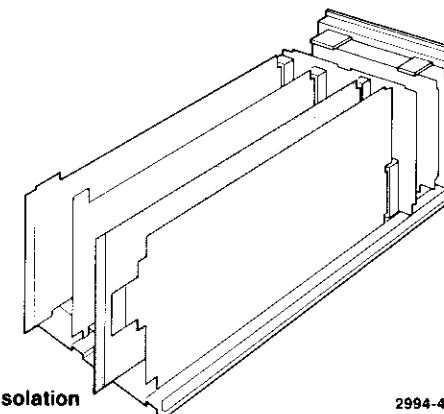

A15 Isolation

2994-41

2994-48

Ⓢ

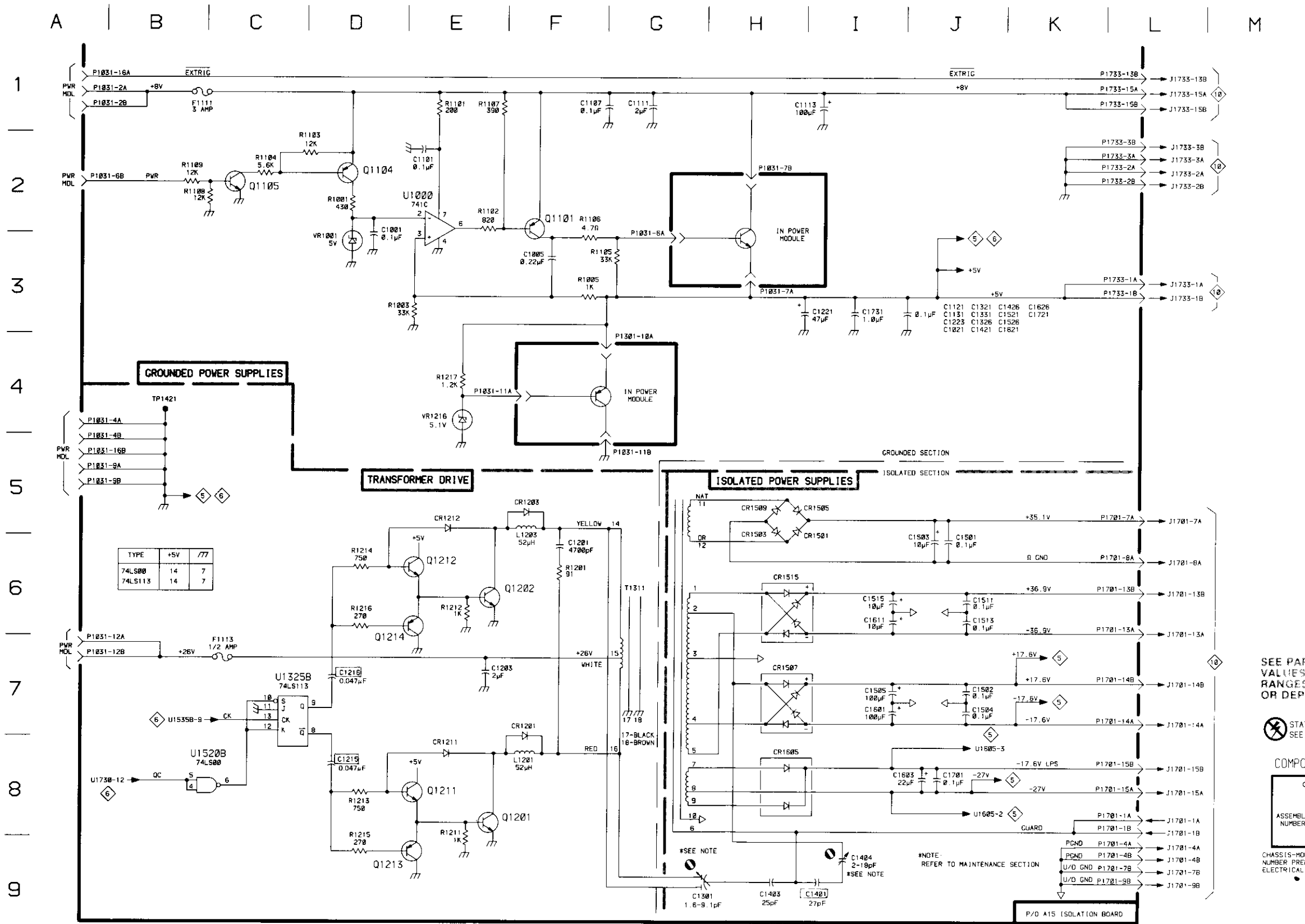

| TYPE | +5V | 7 |
|---------|-----|---|
| 74LS00 | 14 | 7 |
| 74LS113 | 14 | 7 |

SEE PARTS LIST FOR EARLIER VALUES AND SERIAL NUMBER RANGES OF PARTS OUTLINED OR DEPICTED IN GREY.

⊗ STATIC SENSITIVE DEVICES SEE MAINTENANCE SECTION

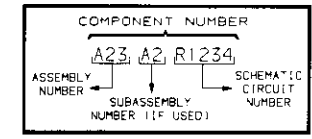

COMPONENT NUMBER EXAMPLE



CHASSIS-MOUNTED COMPONENTS HAVE NO ASSEMBLY NUMBER PREFIX - SEE END OF REPLACEMENT ELECTRICAL PARTS LIST

**Table 10-7
COMPONENT REFERENCE CHART
(See Fig. 10-5)**

| P/O A15 ASSY | | | ISOLATION BOARD  | | |
|----------------|--------------------|----------------|---|--------------------|----------------|
| CIRCUIT NUMBER | SCHEMATIC LOCATION | BOARD LOCATION | CIRCUIT NUMBER | SCHEMATIC LOCATION | BOARD LOCATION |
| C1702 | M3 | K2 | R1713 | L5 | K2 |
| C1713 | M6 | K2 | R1715 | M7 | K2 |
| CR1715 | M7 | K3 | | | |
| P1701 | M7 | L2 | U1135 | J5 | C6 |
| | | | U1230 | I7 | D6 |
| | | | U1330 | G2 | E5 |
| Q1421 | I3 | G3 | U1335 | F5 | F5 |
| Q1615 | K7 | K3 | U1420 | J8 | F4 |
| | | | U1425 | D1 | G4 |
| R1421 | I7 | G4 | U1430 | E6 | F5 |
| R1521 | J1 | H4 | U1435 | E1 | G5 |
| R1526 | J2 | H4 | U1510 | K6 | H3 |
| R1615 | L7 | J2 | U1515 | K1 | H3 |
| R1621 | J3 | J4 | U1530 | C1 | H5 |
| R1626 | J4 | K4 | U1605 | L2 | K2 |
| R1701 | L1 | K2 | U1610 | K2 | J3 |
| R1703 | L2 | K2 | U1613 | L5 | K2 |
| R1711 | L4 | K2 | U1615 | L3 | K3 |
| R1712 | L5 | K2 | U1710 | L4 | K3 |

P/O A15 ASSY also shown on  

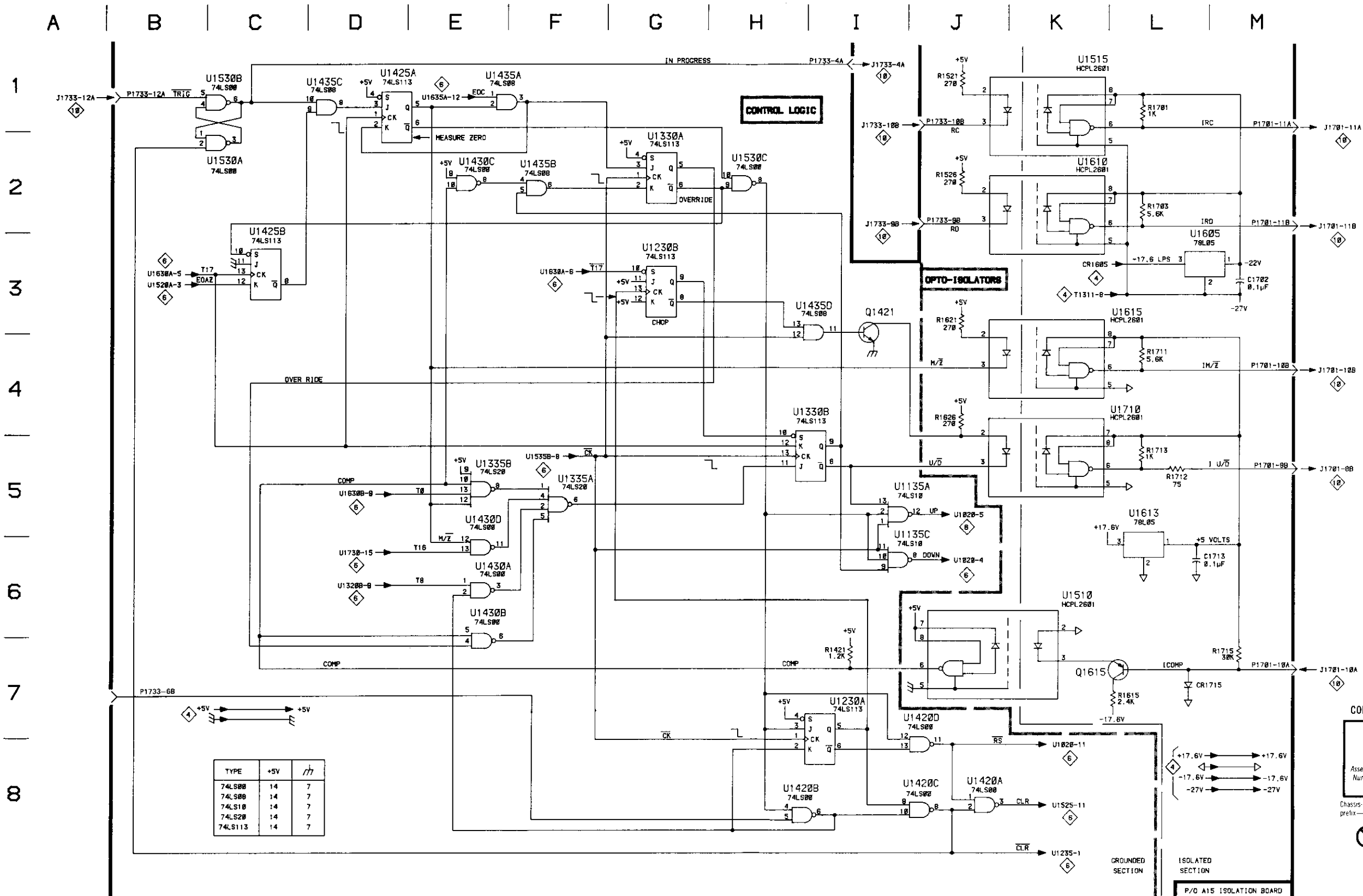

| TYPE | +5V | ⏏ |
|---------|-----|---|
| 74LS00 | 14 | 7 |
| 74LS08 | 14 | 7 |
| 74LS10 | 14 | 7 |
| 74LS20 | 14 | 7 |
| 74LS113 | 14 | 7 |

COMPONENT NUMBER EXAMPLE

Component Number
A23 A2 R1234

Assembly Number Subassembly Number (if used) Schematic Circuit Number



Chassis-mounted components have no Assembly Number prefix—see end of Replaceable Electrical Parts List

Static Sensitive Devices
 See Maintenance Section

COMPONENT REFERENCE CHART

**Table 10-8
COMPONENT REFERENCE CHART
(See Fig. 10-5)**

| P/O A15 ASSY | | | ISOLATION BOARD  | | |
|----------------|--------------------|----------------|---|--------------------|----------------|
| CIRCUIT NUMBER | SCHEMATIC LOCATION | BOARD LOCATION | CIRCUIT NUMBER | SCHEMATIC LOCATION | BOARD LOCATION |
| P1733 | M6 | L5 | U1220 | I5 | E4 |
| R1531 | E1 | H6 | U1235 | J6 | E5 |
| U1020 | L8 | B4 | U1320 | K7 | E4 |
| U1020 | G5 | B4 | U1520 | F6 | H4 |
| U1030 | L6 | B5 | U1525 | E5 | H4 |
| U1120 | L8 | C4 | U1535* | D1 | H5 |
| U1120 | H5 | C4 | U1620 | F6 | J4 |
| U1125 | K6 | D4 | U1625 | F7 | J4 |
| U1130 | L9 | C5 | U1630 | I2 | J5 |
| U1130 | J5 | C5 | U1635 | F7 | J5 |
| U1220 | L8 | E4 | U1720 | F8 | K4 |
| | | | U1730 | D2 | K5 |

P/O A15 ASSY also shown on  

*See Parts List for serial number ranges.

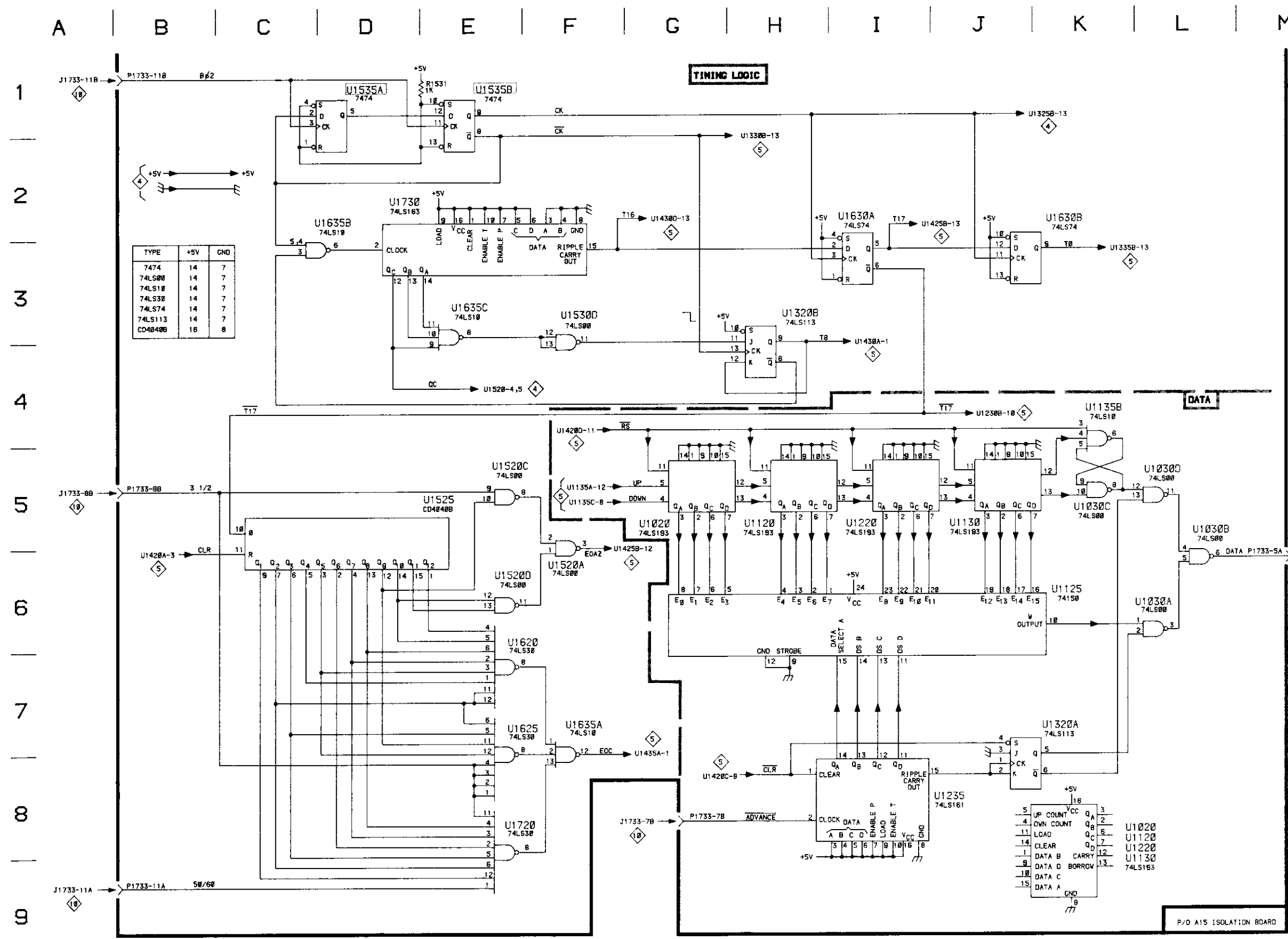

DM 5010

REV JULY 1986

TIMING & DATA GENERATION

2894-105

6

COMPONENT NUMBER EXAMPLE

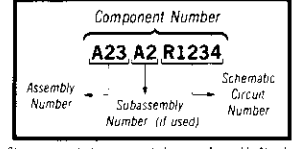



Chassis mounted components have no Assembly Number prefix—see end of Replaceable Electrical Parts List

Static Sensitive Devices
See Maintenance Section

**Table 10-9
COMPONENT REFERENCE CHART**

| P/O A14 ASSY | | | CPU BOARD  | | |
|----------------|--------------------|----------------|---|--------------------|----------------|
| CIRCUIT NUMBER | SCHEMATIC LOCATION | BOARD LOCATION | CIRCUIT NUMBER | SCHEMATIC LOCATION | BOARD LOCATION |
| C1101 | E4 | B1 | R1223 | E3 | D4 |
| C1102 | E4 | C1 | R1225 | D2 | D4 |
| C1201 | E4 | D1 | R1227 | C2 | D4 |
| C1213 | E3 | E3 | R1231 | C3 | D5 |
| C1215 | F3 | E3 | R1232 | C2 | D5 |
| C1223 | D3 | C5 | R1233 | B3 | D6 |
| C1233 | E4 | D6 | R1311 | F3 | F3 |
| C1235 | E5 | E6 | R1313 | F2 | F3 |
| C1301 | E5 | E1 | R1321 | F2 | E4 |
| C1302 | E5 | F1 | R1621 | H3 | J4 |
| C1321 | E4 | E4 | | | |
| C1401 | E4 | G1 | TP1531 | B5 | H6 |
| C1421 | E4 | G3 | TP1533 | H3 | J5 |
| C1426 | E4 | G3 | TP1535 | K5 | J6 |
| C1431 | E5 | G6 | TP1621 | L6 | K4 |
| C1435 | E5 | H5 | TP1625 | K5 | K4 |
| C1501 | E5 | H1 | | | |
| C1521 | E4 | H3 | U1230 | E2 | D5 |
| C1523 | E4 | H4 | U1235 | E6 | E5 |
| C1601 | E4 | J1 | U1320 | G1 | F4 |
| C1602 | E4 | K1 | U1420 | E7 | G4 |
| C1621 | E5 | K4 | U1425 | H4 | G3 |
| C1631 | E5 | K5 | U1430 | K3 | G5 |
| C1721 | E5 | K4 | U1435 | K1 | G5 |
| C1731 | D4 | L5 | U1510 | I6 | H3 |
| | | | U1520 | K8 | H4 |
| J1425 | I3 | G4 | U1620 | K5 | J4 |
| | | | U1720 | L7 | K4 |
| P1425 | I3 | G4 | U1730 | L9 | K5 |
| P1731 | B4 | L5 | | | |
| | | | VR1232 | B2 | D5 |
| R1129 | D2 | C5 | | | |
| R1132 | D3 | C5 | Y1221 | E3 | E4 |
| R1221 | E2 | D4 | | | |

P/O A14 ASSY also shown on  

PARTS LOCATION GRID

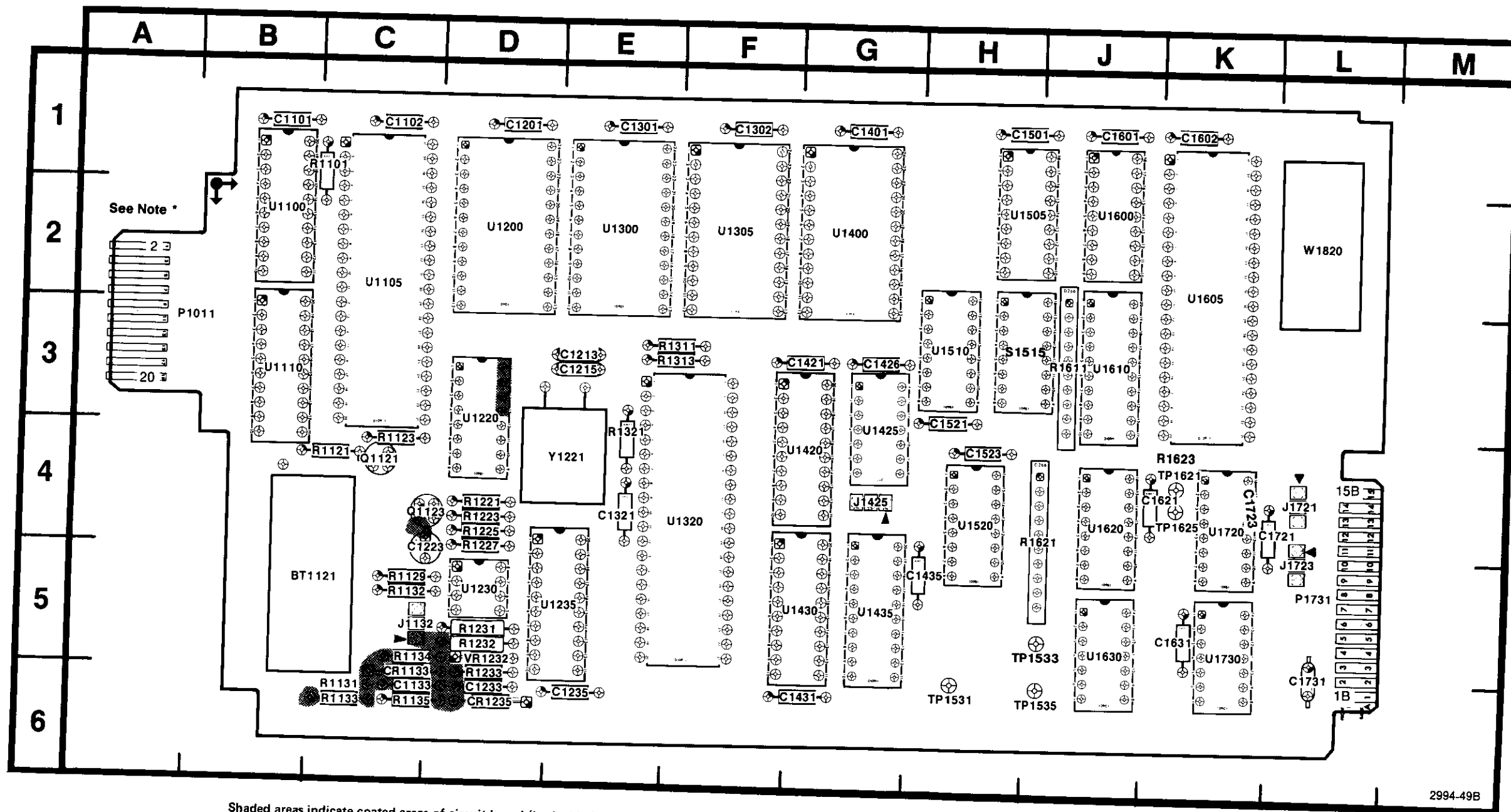

2994-49B

Shaded areas indicate coated areas of circuit board (both sides).
See CPU Board Coating in Maintenance section.

Fig. 10-6. CPU Board (A14).

ASSY A14

Note: Even numbered connections on side shown.
Odd numbered connections on back side of connector.

⊗ Static Sensitive Devices
See Maintenance Section

COMPONENT NUMBER EXAMPLE

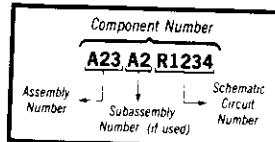

Chassis mounted components have no Assembly Number prefix—see end of Replaceable Electrical Parts List.

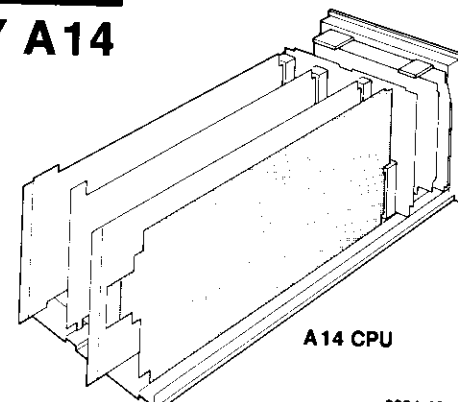

A14 CPU

2994-42

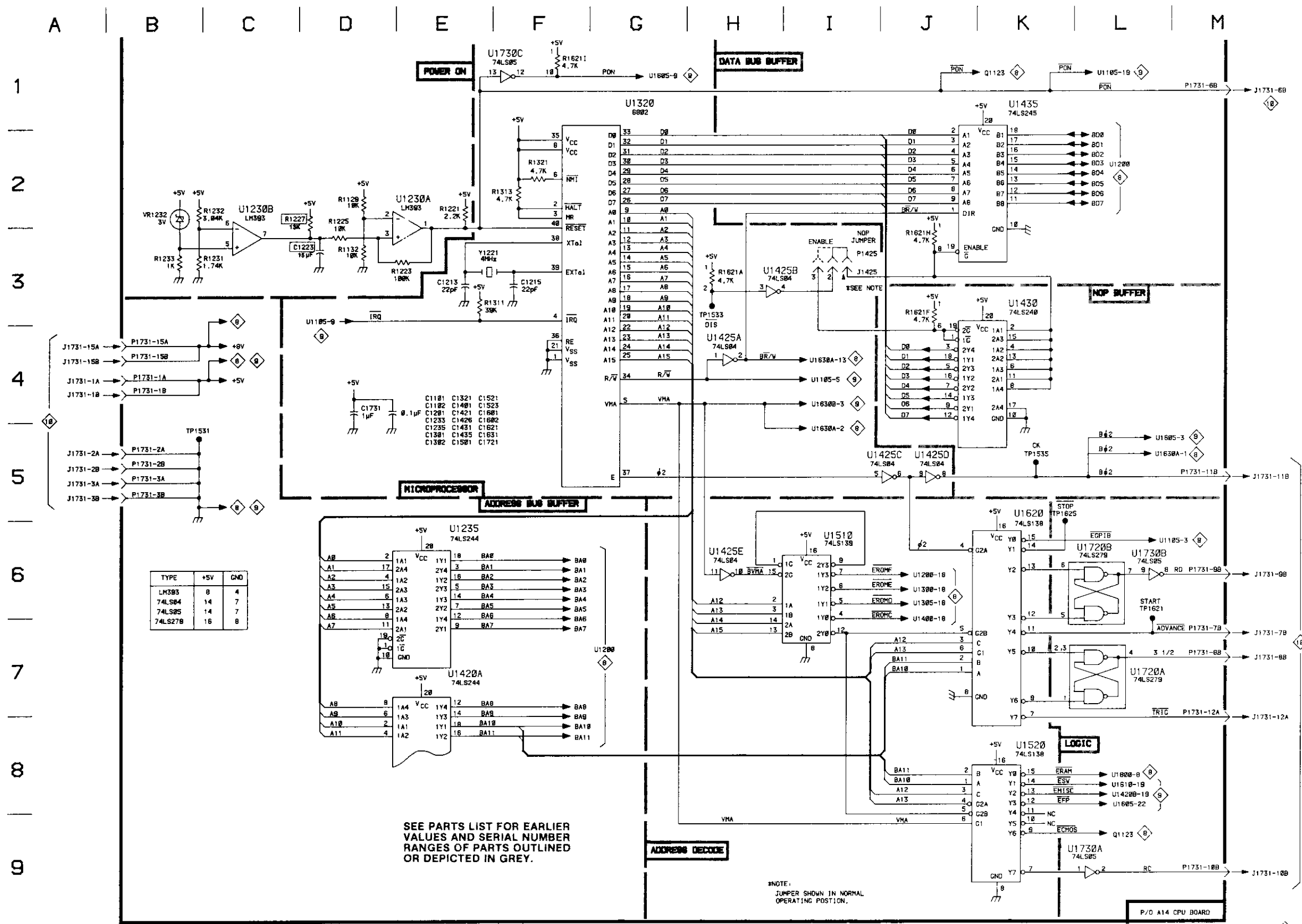

DM 5010

REV JUL 1984

PROCESSOR, ADDRESS DECODE

7

2994-195

DJO

COMPONENT NUMBER EXAMPLE

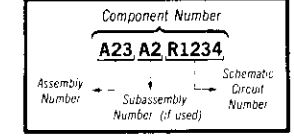

Chassis-mounted components have no Assembly Number pref. - see end of Replaceable Electrical Parts List

⊗ Static Sensitive Devices
See Maintenance Section

SEE PARTS LIST FOR EARLIER VALUES AND SERIAL NUMBER RANGES OF PARTS OUTLINED OR DEPICTED IN GREY.

NOTE:
JUMPER SHOWN IN NORMAL OPERATING POSITION.

P/O A14 CPU BOARD

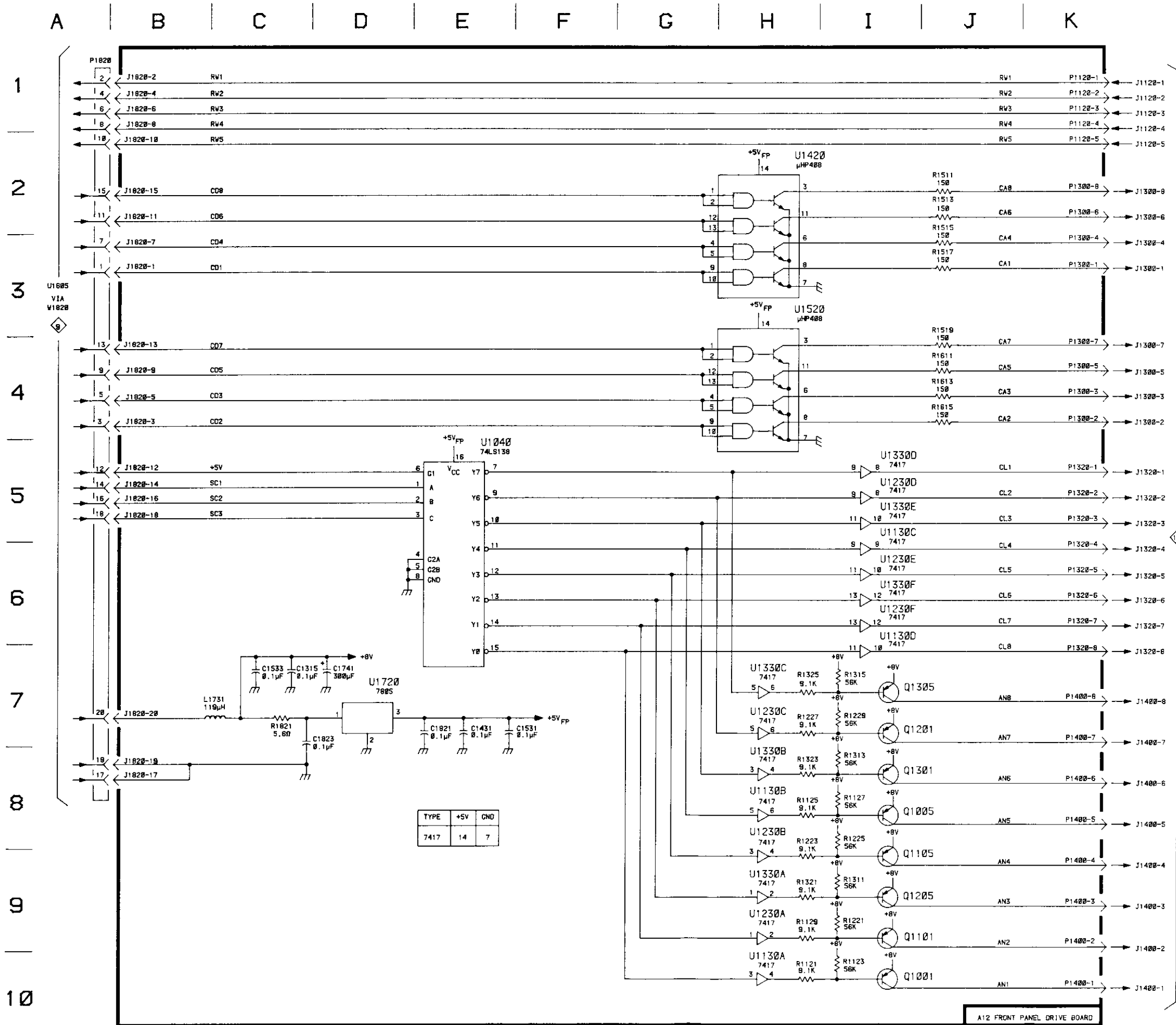

| TYPE | +5V | GND |
|------|-----|-----|
| 7417 | 14 | 7 |

COMPONENT NUMBER EXAMPLE

Component Number
A23 A2 R1234



Assembly Number Subassembly Number (if used) Schematic Circuit Number

Chassis-mounted components have no Assembly Number prefix—see end of Replaceable Electrical Parts List.

Static Sensitive Devices
 See Maintenance Section

**Table 10-10
COMPONENT REFERENCE CHART
(See Fig. 10-6)**

| P/O A14 ASSY | | | CPU BOARD  | | |
|----------------|--------------------|----------------|---|--------------------|----------------|
| CIRCUIT NUMBER | SCHEMATIC LOCATION | BOARD LOCATION | CIRCUIT NUMBER | SCHEMATIC LOCATION | BOARD LOCATION |
| BT1121 | I9 | C5 | R1131 | I8 | C6 |
| C1133 | J8 | C6 | R1133 | J8 | C6 |
| CR1133 | I8 | C6 | R1134 | I8 | C5 |
| CR1235 | H8 | D6 | R1135 | H8 | C6 |
| J1132 | I7 | C5 | U1200 | D2 | D2 |
| J1505 | H5 | H2 | U1220 | K6 | D3 |
| P1132 | I7 | C5 | U1300 | F2 | E2 |
| Q1123 | I8 | C4 | U1305 | H2 | F2 |
| | | | U1400 | K2 | G2 |
| | | | U1505 | H5 | H2 |
| | | | U1600 | F5 | J2 |

P/O A14 ASSY also shown on  

PARTS LOCATION GRID

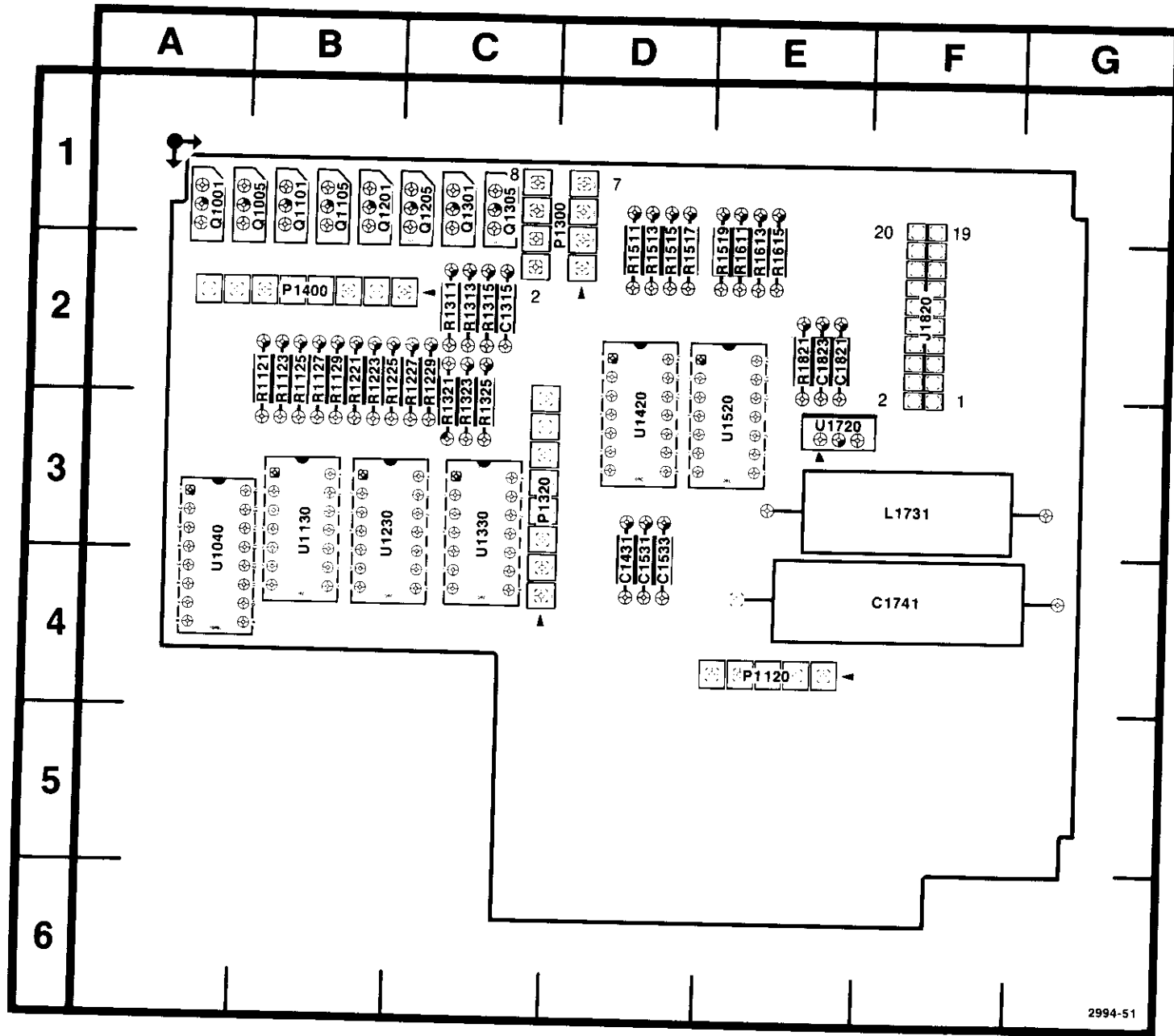

Fig. 10-8. Front Panel Drive Board (A12).

ASSY A12

Table 10-16 COMPONENT REFERENCE CHART

| A 12 ASSY | | | FRONT PANEL DRIVE BOARD 11 | | |
|----------------|--------------------|----------------|--|--------------------|----------------|
| CIRCUIT NUMBER | SCHEMATIC LOCATION | BOARD LOCATION | CIRCUIT NUMBER | SCHEMATIC LOCATION | BOARD LOCATION |
| C1315 | C7 | C2 | R1127 | I8 | B2 |
| C1431 | E7 | D4 | R1129 | H9 | B2 |
| C1531 | F7 | D4 | R1221 | I9 | B2 |
| C1533 | C7 | D4 | R1223 | H8 | B2 |
| C1741 | D7 | F4 | R1225 | I8 | B2 |
| C1821 | E7 | E2 | R1227 | H7 | C2 |
| C1823 | D7 | E2 | R1229 | I7 | C2 |
| J1820 | B3 | F2 | R1311 | I9 | C2 |
| L1731 | C7 | F3 | R1313 | I8 | C2 |
| P1120 | K1 | E4 | R1315 | I7 | C2 |
| P1300 | K3 | D1 | R1321 | H9 | C3 |
| P1320 | K5 | C3 | R1323 | H8 | C3 |
| P1400 | K9 | B2 | R1325 | H7 | C3 |
| P1400 | K10 | B2 | R1511 | J2 | D2 |
| P1820 | A1 | F2 | R1513 | J2 | D2 |
| Q1001 | J10 | A1 | R1515 | J2 | D2 |
| Q1005 | J8 | B1 | R1517 | J3 | D2 |
| Q1101 | J9 | B1 | R1519 | J3 | E2 |
| Q1105 | J9 | B1 | R1611 | J4 | E2 |
| Q1201 | J7 | B1 | R1613 | J4 | E2 |
| Q1205 | J9 | C1 | R1615 | J4 | E2 |
| Q1301 | J8 | C1 | R1821 | C7 | E2 |
| Q1305 | J7 | C1 | U1040 | E5 | A4 |
| R1121 | H10 | B2 | U1130 | H10 | B3 |
| R1123 | I10 | B2 | U1230 | H8 | B3 |
| R1125 | H8 | B2 | U1330 | H8 | C3 |
| | | | U1420 | H2 | D3 |
| | | | U1520 | H3 | E3 |
| | | | U1720 | D7 | E3 |

Static Sensitive Devices
See Maintenance Section

COMPONENT NUMBER EXAMPLE

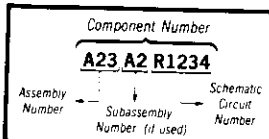

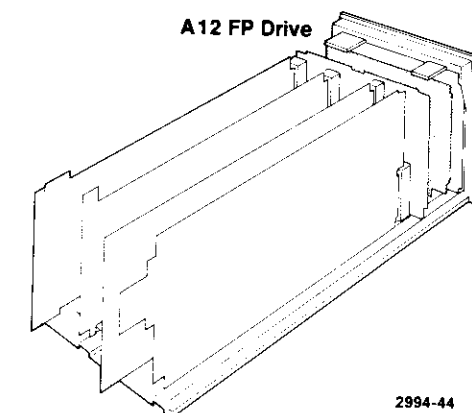

Chassis-mounted components have no Assembly Number prefix—see end of Replaceable Electrical Parts list



**Table 10-11
COMPONENT REFERENCE CHART
(See Fig. 10-6)**

| P/O A14 ASSY | | | CPU BOARD  | | |
|----------------|--------------------|----------------|---|--------------------|----------------|
| CIRCUIT NUMBER | SCHEMATIC LOCATION | BOARD LOCATION | CIRCUIT NUMBER | SCHEMATIC LOCATION | BOARD LOCATION |
| C1723* | C4 | K4 | R1623* | C5 | J4 |
| J1721 | C4 | L4 | S1515 | D6 | H3 |
| J1723 | C5 | L4 | | | |
| P1011 | K5 | A3 | U1100 | J5 | B2 |
| P1721 | C3 | L4 | U1105 | H5 | C2 |
| P1723 | C5 | L4 | U1110 | J7 | B3 |
| | | | U1605 | I1 | K2 |
| Q1121 | J7 | C4 | U1610 | F6 | J3 |
| | | | U1630 | G1 | J5 |
| R1101 | G7 | C1 | U1720 | D3 | K4 |
| R1121 | H6 | C4 | | | |
| R1123* | J7 | C4 | W1820 | K2 | L2 |
| R1611 | D6 | J3 | | | |

P/O A14 ASSY also shown on  

*See Parts List for
serial number ranges.

A | B | C | D | E | F | G | H | I | J | K | L

1
2
3
4
5
6
7
8
9

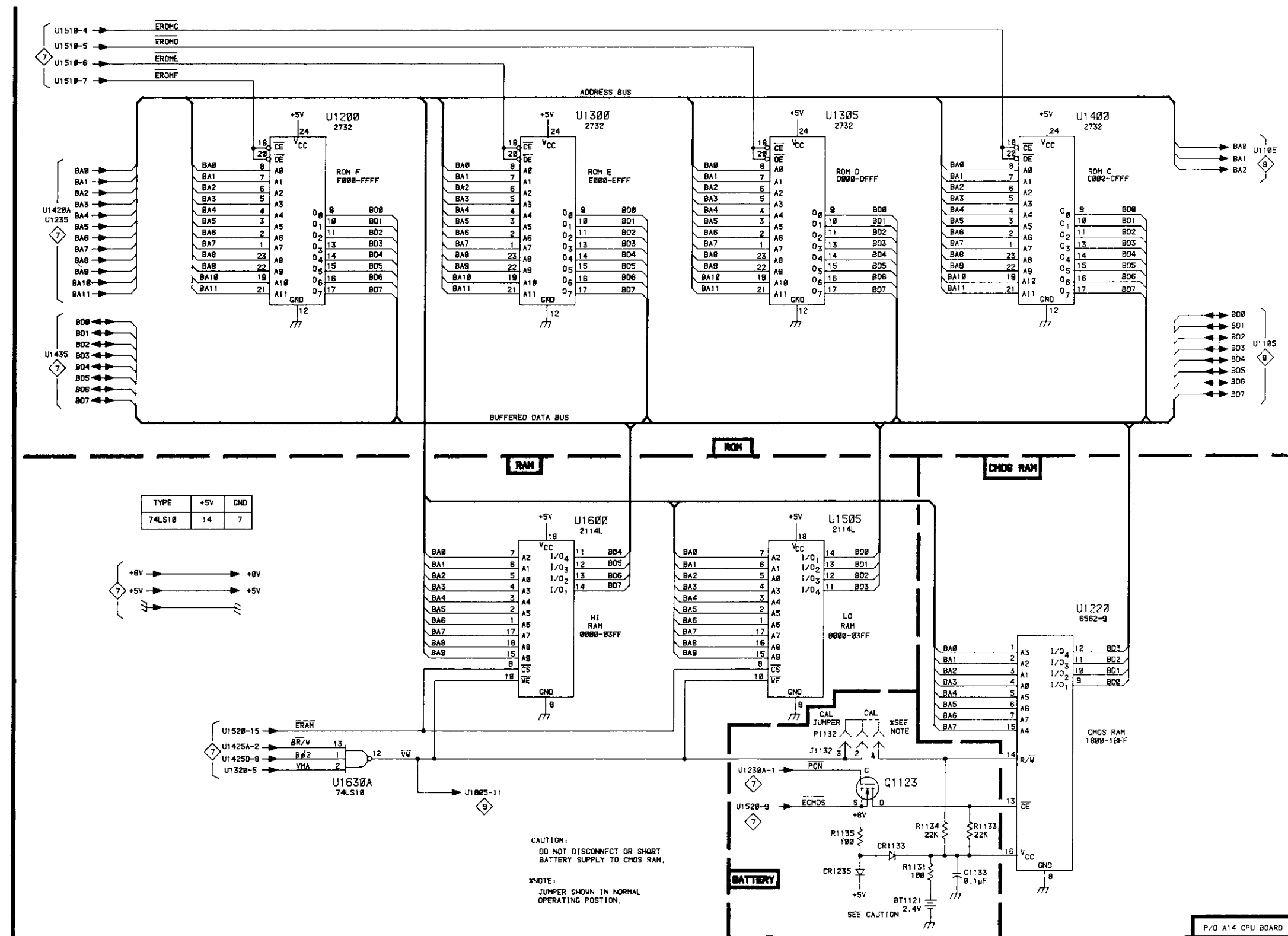

COMPONENT NUMBER EXAMPLE

Component Number
A23 A2 R1234

Assembly Number Schematic Circuit Number
 Subassembly Number (if used)

Chassis-mounted components have no Assembly Number prefix—see end of Replaceable Electrical Parts List

Static Sensitive Devices
See Maintenance Section

COMPONENT REFERENCE CHART

Table 10-14 REAR INTERFACE CONNECTOR ASSIGNMENTS ISOLATION BOARD (A15)

| FUNCTION | PIN B | | PIN A | FUNCTION |
|-----------------------------------|-------|----------------------------|-------|---------------------------------|
| GROUND | 16 | TM 5000 BARRIER SLOT | 16 | EXTRIG * |
| | 15 | | 15 | |
| | 14 | | 14 | |
| | 13 | | 13 | |
| +26V DC | 12 | | 12 | +26V DC |
| COLLECTOR LEAD OF PNP SERIES PASS | 11 | | 11 | BASE LEAD OF PNP SERIES PASS |
| | 10 | | 10 | EMITTER LEAD OF PNP SERIES PASS |
| GROUND | 9 | | 9 | GROUND |
| | 8 | | 8 | |
| COLLECTOR LEAD OF NPN SERIES PASS | 7 | | 7 | EMITTER LEAD OF NPN SERIES PASS |
| PWR | 6 | | 6 | BASE LEAD OF NPN SERIES PASS |
| | 5 | | 5 | |
| GROUND | 4 | | 4 | GROUND |
| | 3 | | 3 | |
| +8 FILTERED VDC | 2 | | 2 | +8 FILTERED VDC |
| | 1 | | 1 | |

*REQUIRES INSTALLATION OF INTERNAL JUMPER.

PLUG-IN REAR VIEW



**Table 10-15
REAR INTERFACE
CONNECTOR ASSIGNMENTS
ADC BOARD (A17)**

| FUNCTION | PIN B | | PIN A | FUNCTION |
|----------|----------|---------------------------|----------|----------|
| HI INPUT | 28 | DM BARRIER SLOT | 28 | LO INPUT |
| | 27 | | 27 | |
| | 26 | | 26 | |
| | 25 | | 25 | |
| | 24 | | 24 | |
| | 23 | | 23 | |
| | 22 | | 22 | |
| | 21 | | 21 | |
| | 20 | | 20 | |
| | 19 | | 19 | |
| | 18 | | 18 | |
| | 17 | | 17 | |
| | 16 | | 16 | |
| | 15 | | 15 | |
| | 14 | 14 | | |

PLUG-IN REAR VIEW

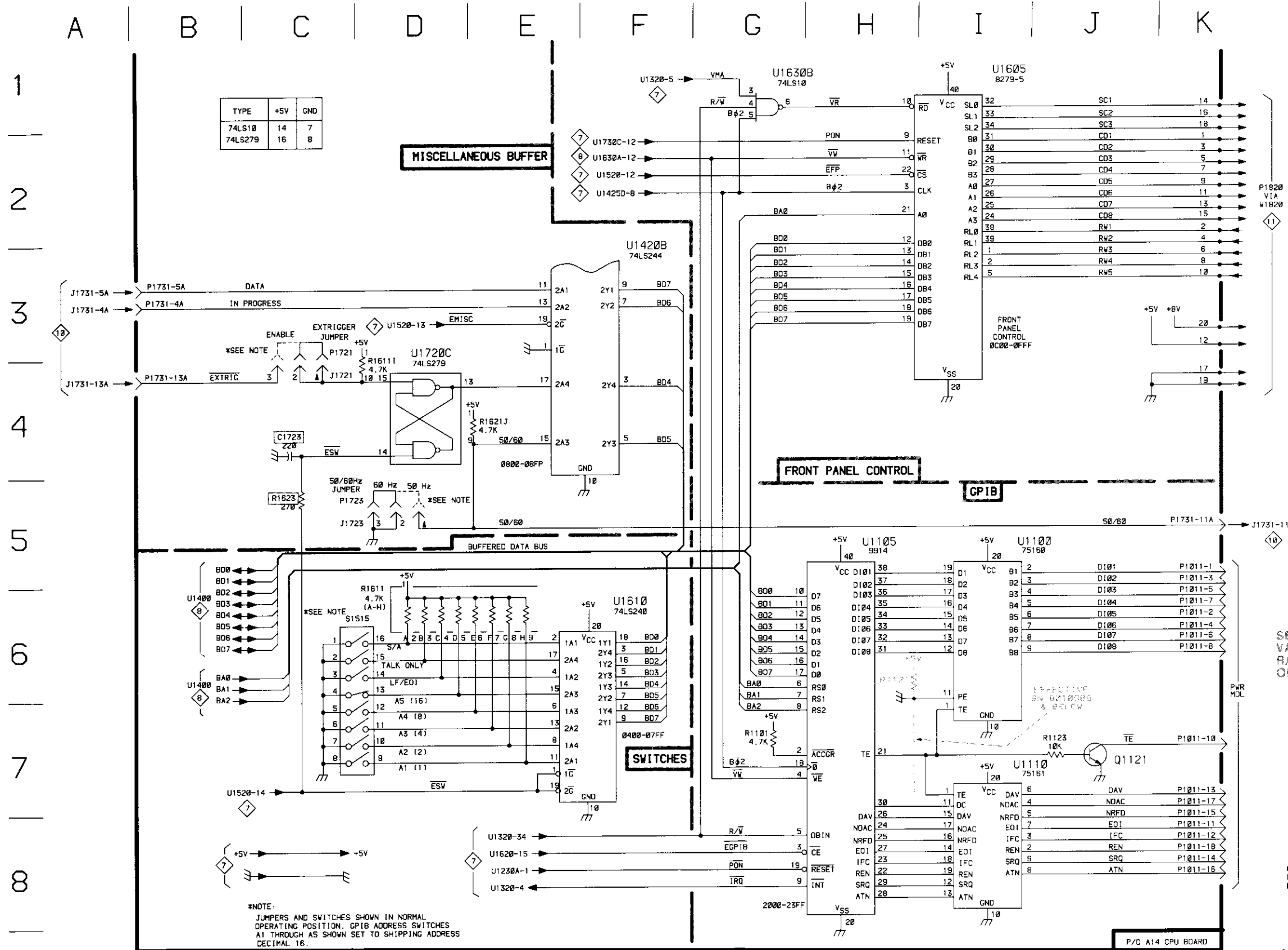

SEE PARTS LIST FOR EARLIER VALUES AND SERIAL NUMBER RANGES OF PARTS OUTLINED OR DEPICTED IN GREY.

 STATIC SENSITIVE DEVICES
SEE MAINTENANCE SECTION

COMPONENT NUMBER EXAMPLE

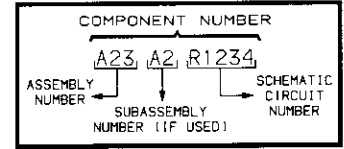

CHASSIS-MOUNTED COMPONENTS HAVE NO ASSEMBLY NUMBER PREFIX—SEE END OF REPLACEABLE ELECTRICAL PARTS LIST

PARTS LOCATION GRID

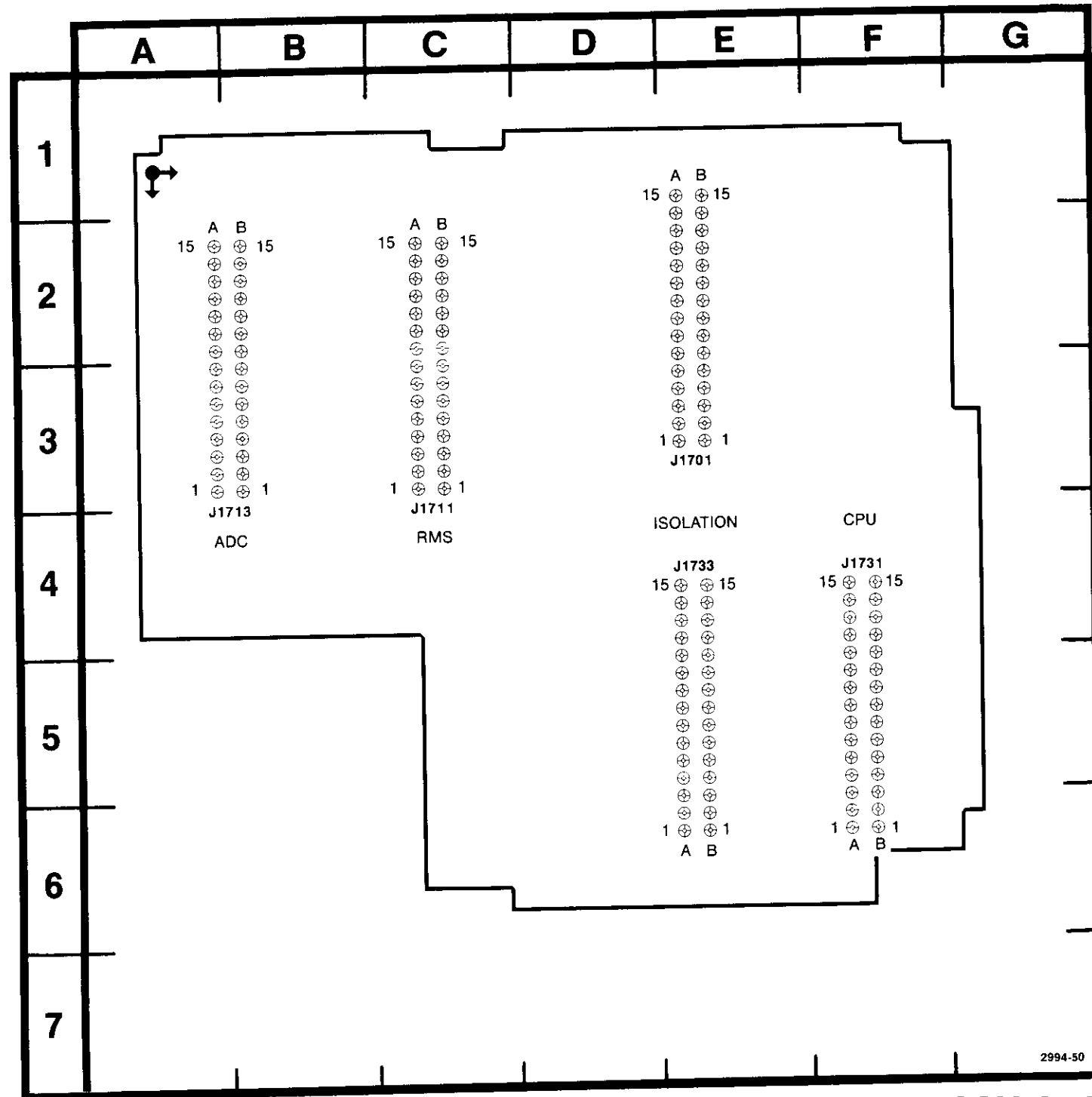
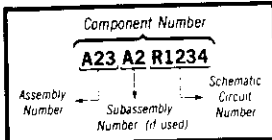

Fig. 10-7. Main Interconnect Board (A13).

ASSY A13

⊗ Static Sensitive Devices
See Maintenance Section

COMPONENT NUMBER EXAMPLE



Chassis-mounted components have no Assembly Number prefix—see end of Replaceable Electrical Parts List

**Table 10-12
COMPONENT REFERENCE CHART**

| A13 ASSY | | | MAIN INTERCONNECT BOARD 10 | | |
|-------------------------|--------------------|----------------|--|--------------------|----------------|
| CIRCUIT NUMBER | SCHEMATIC LOCATION | BOARD LOCATION | CIRCUIT NUMBER | SCHEMATIC LOCATION | BOARD LOCATION |
| J1701 J1711 J1713 | E1 G1 J1 | E3 C4 B4 | J1731 J1733 | C6 E6 | E5 E4 |

**Table 10-13
REAR INTERFACE
CONNECTOR ASSIGNMENTS
CPU BOARD (A14)**

| FUNCTION | PIN | | PIN | FUNCTION |
|----------|-----|--|-----|----------|
| D101 | 1 | | 2 | D105 |
| D102 | 3 | | 4 | D106 |
| D103 | 5 | | 6 | D107 |
| D104 | 7 | | 8 | D108 |
| | 9 | | 10 | |
| E01 | 11 | | 12 | IFC |
| DAV | 13 | | 14 | SRQ |
| NRFD | 15 | | 16 | ATN |
| NDAC | 17 | | 18 | REN |
| | 19 | | 20 | |

PLUG-IN REAR VIEW

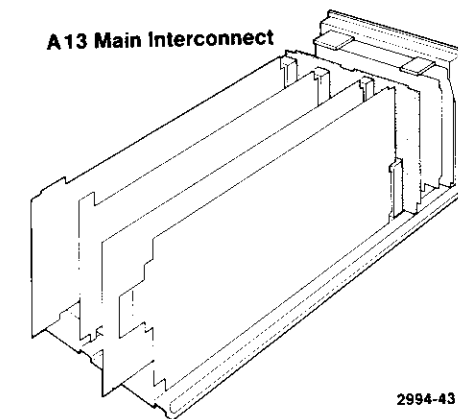

REV DEC 1982

2994-43

REAR INTERFACE CONNECTORS

1
2
3
4
5
6
7
8
9

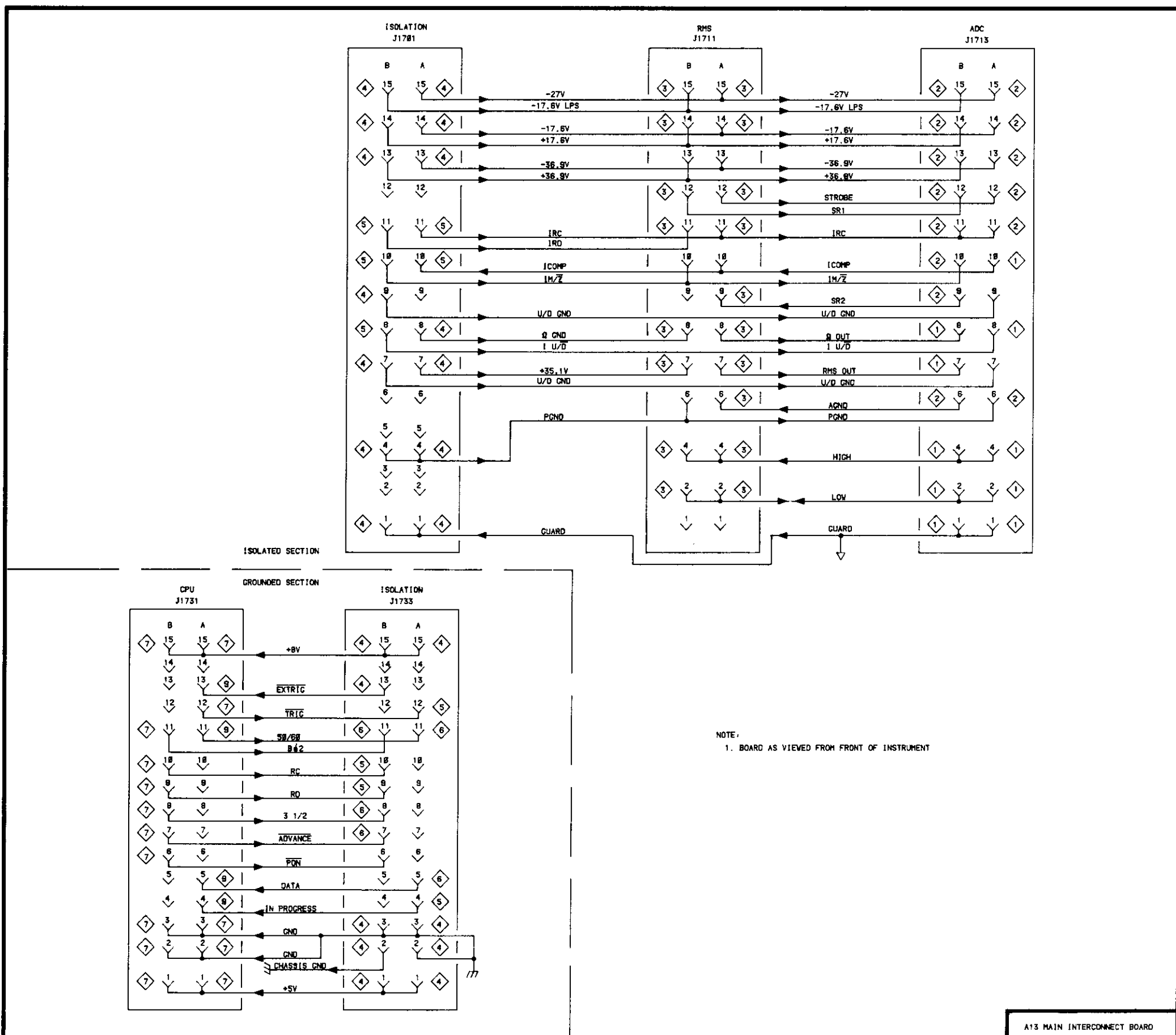

NOTE:
1. BOARD AS VIEWED FROM FRONT OF INSTRUMENT

COMPONENT NUMBER EXAMPLE

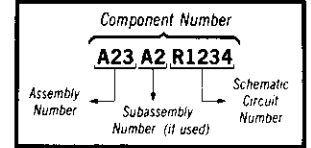

Chassis-mounted components have no Assembly Number prefix—see end of Replaceable Electrical Parts List.

⊗ Static Sensitive Devices
See Maintenance Section



PARTS LOCATION GRID

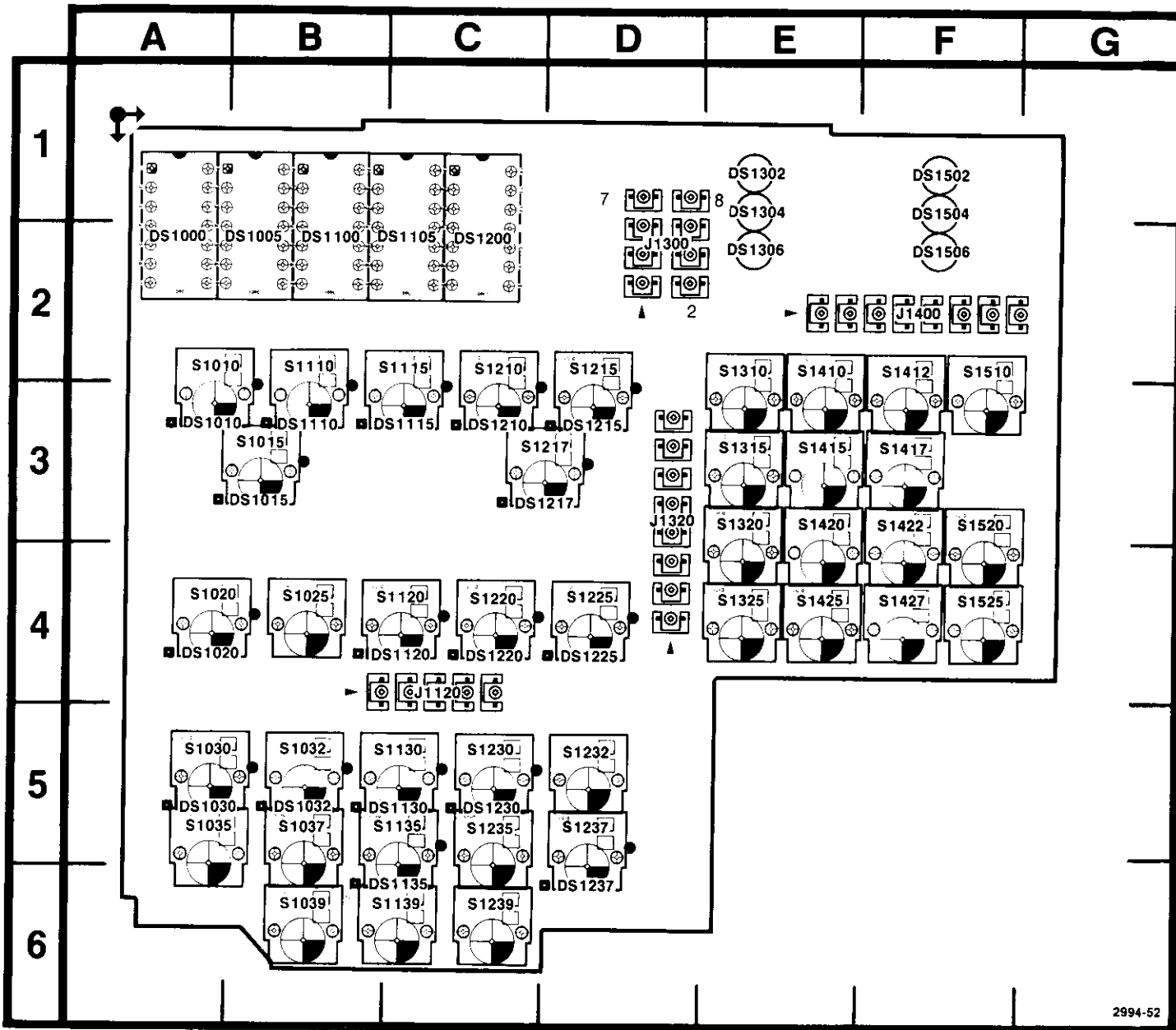

Fig. 10-9. Front Panel Board (A11).

ASSY A11

Table 10-17 COMPONENT REFERENCE CHART

| A11 ASSY | | | FRONT PANEL BOARD 12 | | |
|----------------|--------------------|----------------|--|--------------------|----------------|
| CIRCUIT NUMBER | SCHEMATIC LOCATION | BOARD LOCATION | CIRCUIT NUMBER | SCHEMATIC LOCATION | BOARD LOCATION |
| DS1000 | B5 | A2 | S1025 | H7 | B4 |
| DS1005 | D5 | B2 | S1030 | I7 | A5 |
| DS1010 | K2 | A3 | S1032 | I7 | B5 |
| DS1015 | J1 | B3 | S1035 | J7 | A5 |
| DS1020 | H2 | A4 | S1037 | J7 | B5 |
| DS1030 | J3 | A5 | S1039 | G7 | B6 |
| DS1032 | J5 | B5 | S1110 | F7 | B2 |
| DS1100 | E5 | B2 | S1115 | F8 | C2 |
| DS1105 | F5 | C2 | S1120 | H8 | C4 |
| DS1110 | K5 | B3 | S1130 | I8 | C5 |
| DS1115 | K5 | C3 | S1135 | J8 | C5 |
| DS1120 | H5 | C4 | S1139 | G8 | C6 |
| DS1130 | J5 | C5 | S1210 | F8 | C2 |
| DS1135 | J2 | C6 | S1215 | F9 | D2 |
| DS1200 | G5 | C2 | S1217 | G9 | D3 |
| DS1210 | K3 | C3 | S1220 | H8 | C4 |
| DS1215 | K4 | D3 | S1225 | H9 | D4 |
| DS1217 | J2 | D3 | S1230 | I8 | C5 |
| DS1220 | H4 | C4 | S1232 | I9 | D5 |
| DS1225 | H3 | D4 | S1235 | J8 | C5 |
| DS1230 | J4 | C5 | S1237 | J9 | D5 |
| DS1237 | J3 | D6 | S1239 | G8 | C6 |
| DS1302 | H5 | E1 | S1310 | D8 | E2 |
| DS1304 | H3 | E1 | S1315 | C9 | E3 |
| DS1306 | H2 | E2 | S1320 | C7 | E3 |
| DS1502 | K1 | F1 | S1325 | C7 | E4 |
| DS1504 | K2 | F1 | S1410 | D8 | E2 |
| DS1506 | K3 | F2 | S1412 | D9 | F2 |
| | | | S1415 | D7 | E3 |
| | | | S1417 | D7 | F3 |
| | | | S1420 | C8 | E3 |
| | | | S1422 | C8 | F3 |
| | | | S1425 | E7 | E4 |
| | | | S1427 | E8 | F4 |
| | | | S1510 | E9 | F2 |
| | | | S1520 | E8 | F3 |
| | | | S1525 | E7 | F4 |
| J1120 | B7 | C4 | | | |
| J1300 | B5 | D2 | | | |
| J1320 | B6 | D3 | | | |
| J1400 | B4 | F2 | | | |
| S1010 | F7 | A2 | | | |
| S1015 | G7 | B3 | | | |
| S1020 | H7 | A4 | | | |

A11 Front Panel

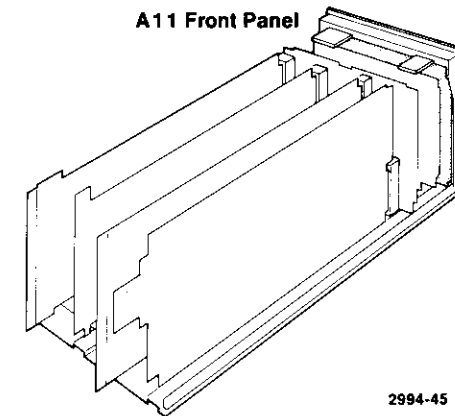

2994-45

Static Sensitive Devices
See Maintenance Section

COMPONENT NUMBER EXAMPLE

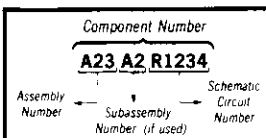

Chassis-mounted components have no Assembly Number prefix—see end of Replaceable Electrical Parts List

@

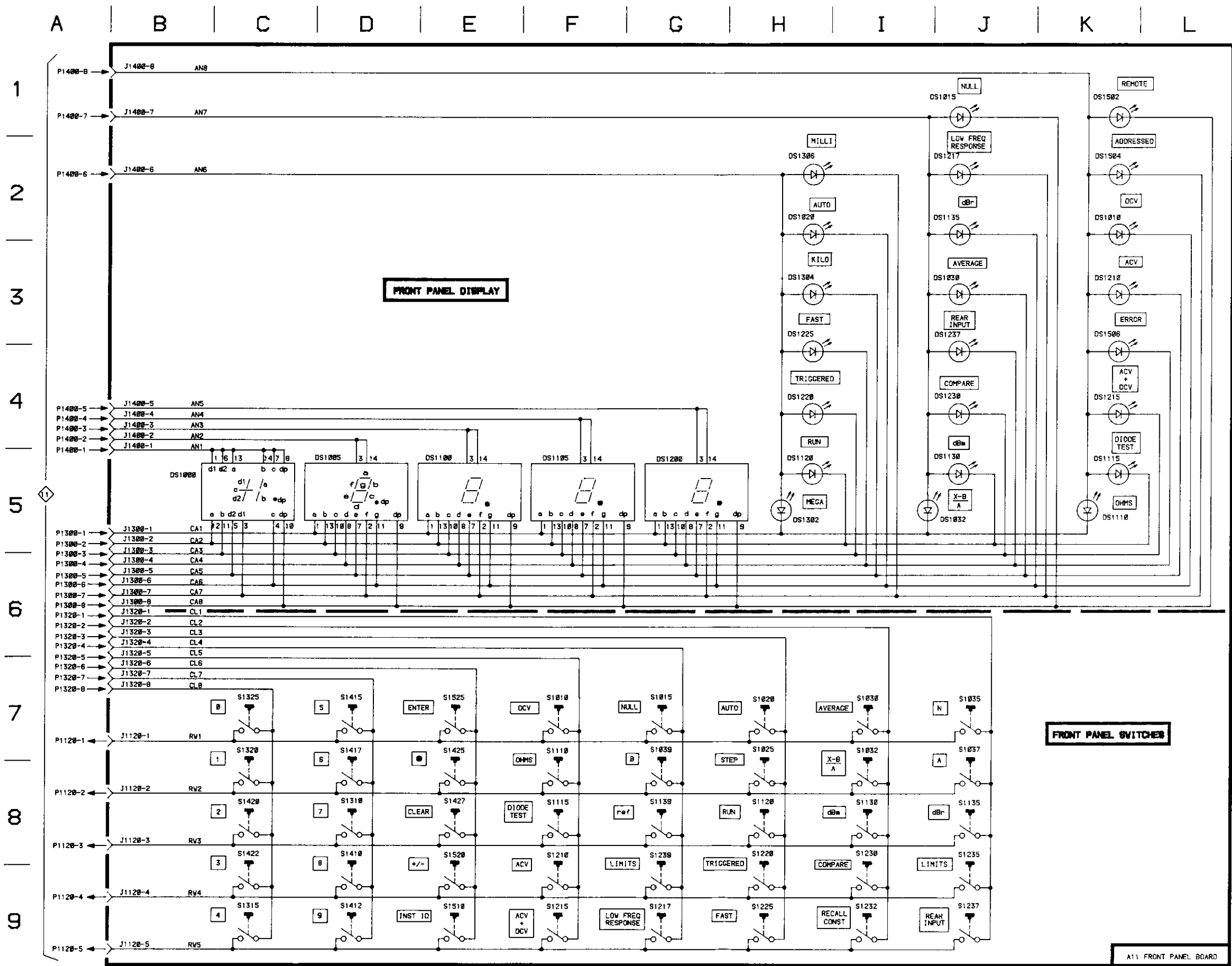

DM 5010

2994-111

A11 FRONT PANEL BOARD
FRONT PANEL

COMPONENT NUMBER EXAMPLE

Component Number
A23 A2 R1234

Assembly Number Subassembly Number (if used) Schematic Circuit Number

Chassis-mounted components have no Assembly Number prefix - see end of Replaceable Electrical Parts List

Static Sensitive Devices
See Maintenance Section

12

030

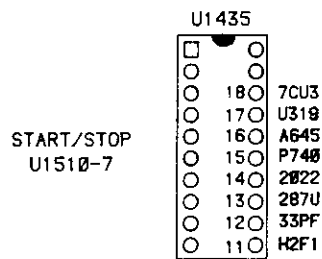
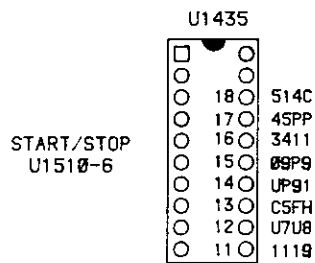
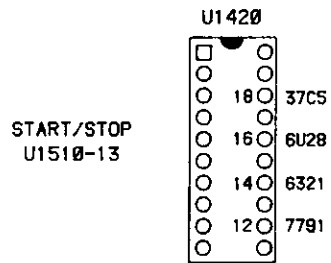

■ AFTER TESTS ARE COMPLETED, RETURN
NOP JUMPER TO DISABLE POSITION.

SIGNATURE TABLE 10A SIGNATURE VERSION 1.0

- FOR TESTING: MICROPROCESSOR, ROMs, AND ADDRESS DECODING.
- ON ASSEMBLY: A14, CPU BOARD.
- EQUIPMENT REQUIRED: SA 501 SIGNATURE ANALYZER
TM 5000 SERIES POWER MODULE
EXTENDER CABLE (067-0645-02)
- ELECTRICAL CONDITIONS
NECESSARY TO PERFORM TEST: +5V SUPPLY REGULATING PROPERLY.
- DM 5010 SETUP: NOP JUMPER IN ENABLE POSITION.
- SA 501 SETUP: GND TO TP1531.
THRESHOLD = TTL.
QUALIFIER OFF.
CLOCK (SEE STEP 1,2,3)
START AND STOP TIED TOGETHER. MAKE CONNECTION TO CPU BOARD
AS INDICATED IN INDIVIDUAL TESTS.
START, STOP AND CLOCK SLOPE - REFER TO INDIVIDUAL TESTS.

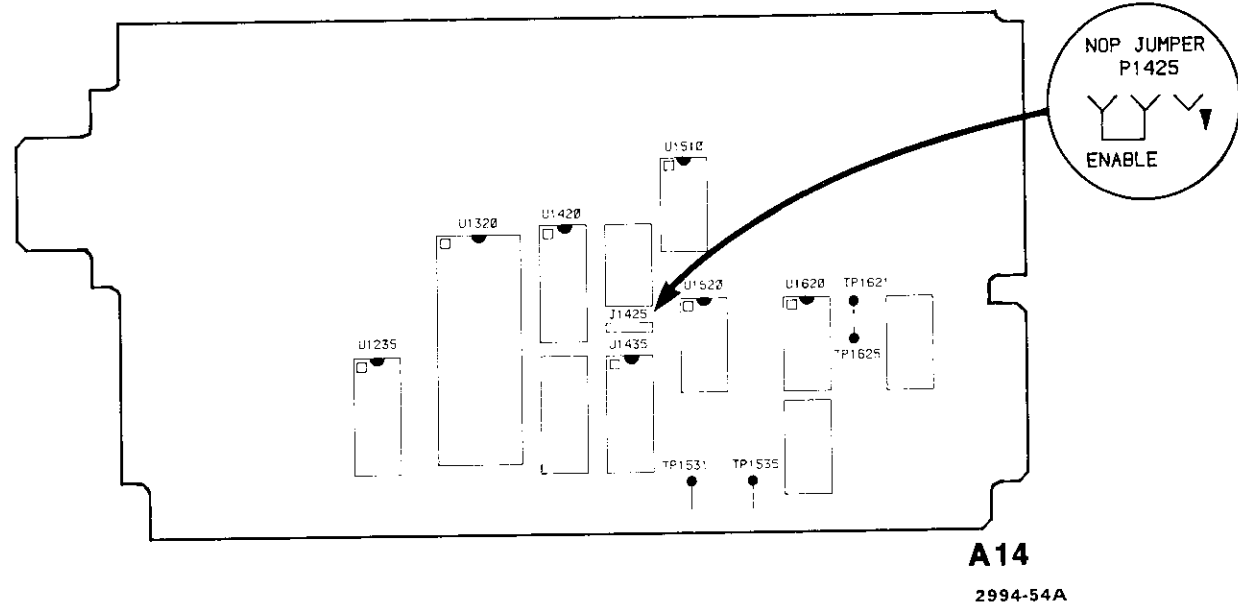
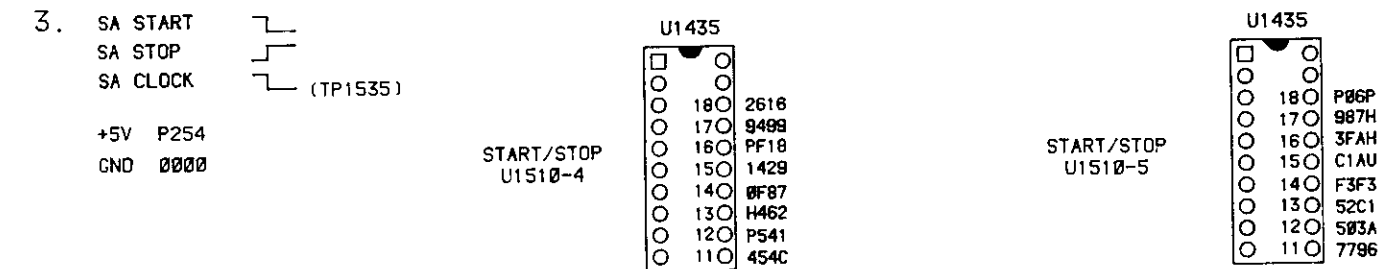
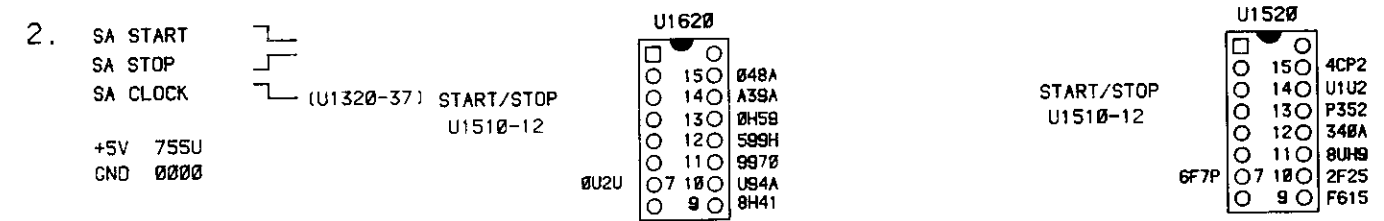
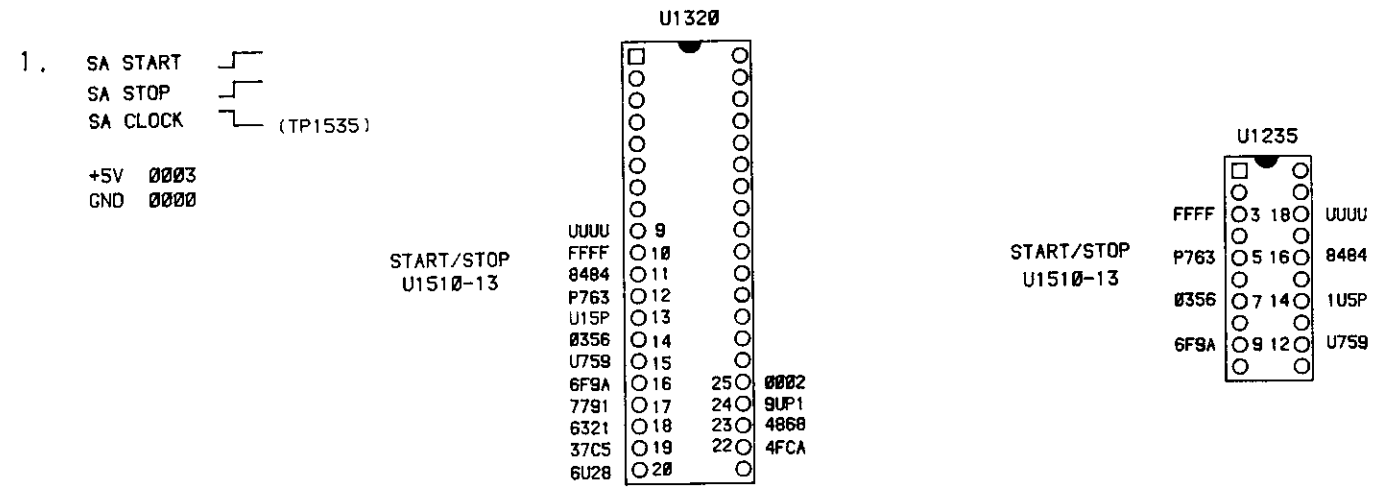





Fig. 10-10. CPU board signature analysis.



SIGNATURE TABLE 10B

SIGNATURE VERSION 1.0

- FOR TESTING: RANGE SHIFT REGISTERS.
- ON ASSEMBLIES: A15, ISOLATION BOARD.
A16, RMS BOARD.
A17, ADC BOARD.
FOR EACH TEST, PLACE THE BOARD
ON EXTENDER BOARD(S).
- EQUIPMENT REQUIRED: SA 501 SIGNATURE ANALYZER.
TM 5000 - SERIES POWER MODULE.
DM 5010 SERVICE KIT (067-1052-00)
EXTENDER CABLE (067-0645-02).
- DM 5010 SETUP: SIGNATURE ANALYZER SWITCH (ON CPU BOARD)
TO SIGNATURE ANALYSIS POSITION. DO NOT
CHANGE THE OTHER SWITCHES.
- SA 501 SETUP: THRESHOLD = TTL.
QUALIFIER OFF.
CLOCK  - CONNECT TO TP1535 ON CPU BOARD.
START  - CONNECT TO TP1621 ON CPU BOARD.
STOP  - CONNECT TO TP1625 ON CPU BOARD.
GND - CONNECT TO TP1531 ON CPU BOARD.
SEE FIG. 10-10, CPU BOARD.

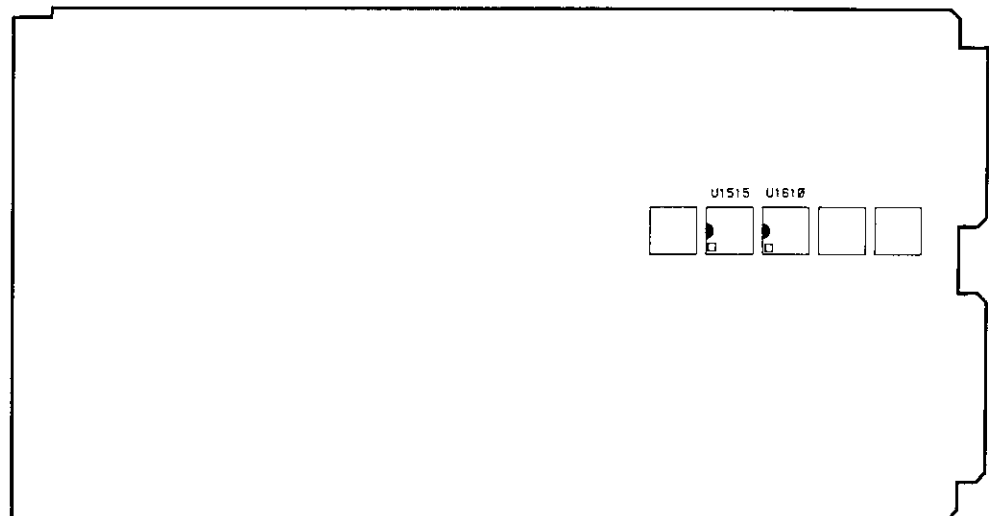

A15

2994-55

Fig. 10-11. Isolation board signature analysis.

- CONNECT U1515-5 (ISOLATED -27V) TO TP 1531 (CHASSIS GROUND) ON CPU BOARD.

+5V 3SPP
GND 0000

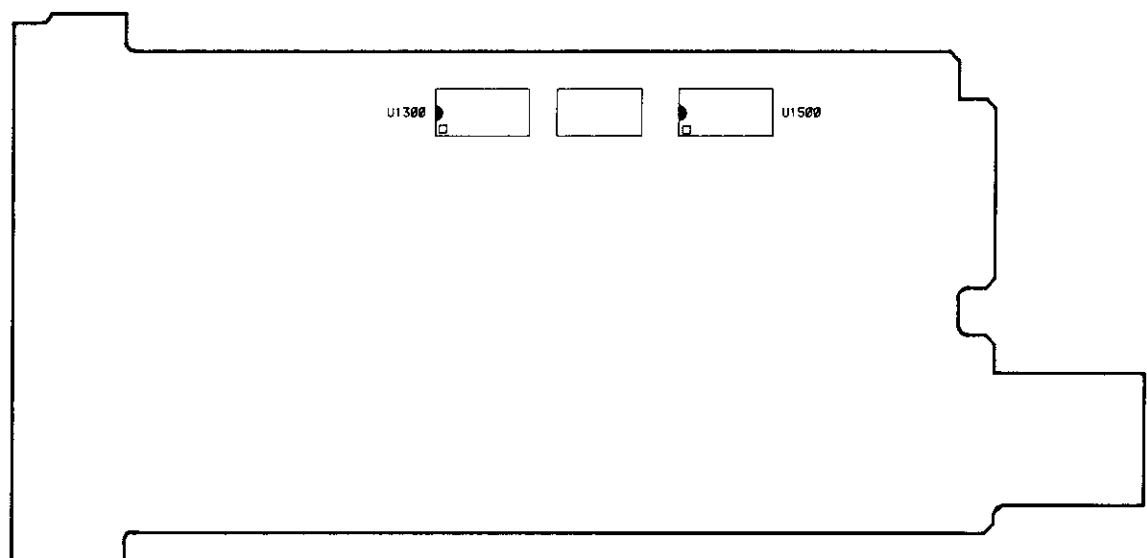
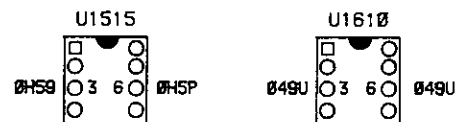

A16

2994-56

Fig. 10-12. ADC board signature analysis.

- CONNECT U1500-8 (ISOLATED -27V) TO TP1531 (CHASSIS GROUND) ON CPU BOARD.



- CONNECT U1330-8 (ISOLATED -27V) TO TP1531 (CHASSIS GROUND) ON CPU BOARD.

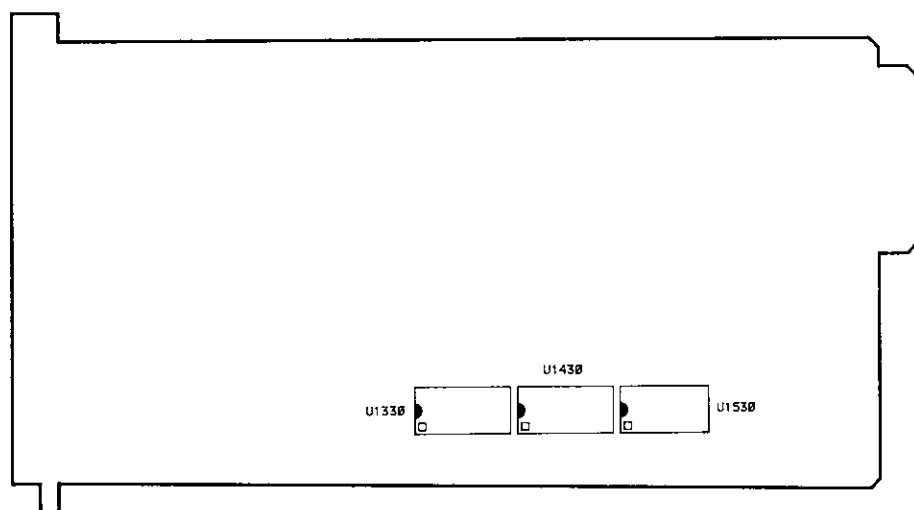

A17

2994-57

Fig. 10-13. RMS board signature analysis.

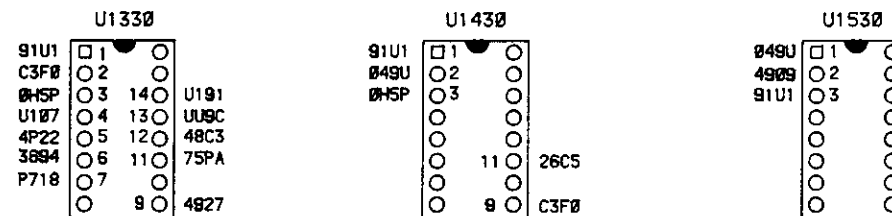

■ AFTER TESTS ARE COMPLETED, RESET THE SIGNATURE ANALYSIS SWITCH.

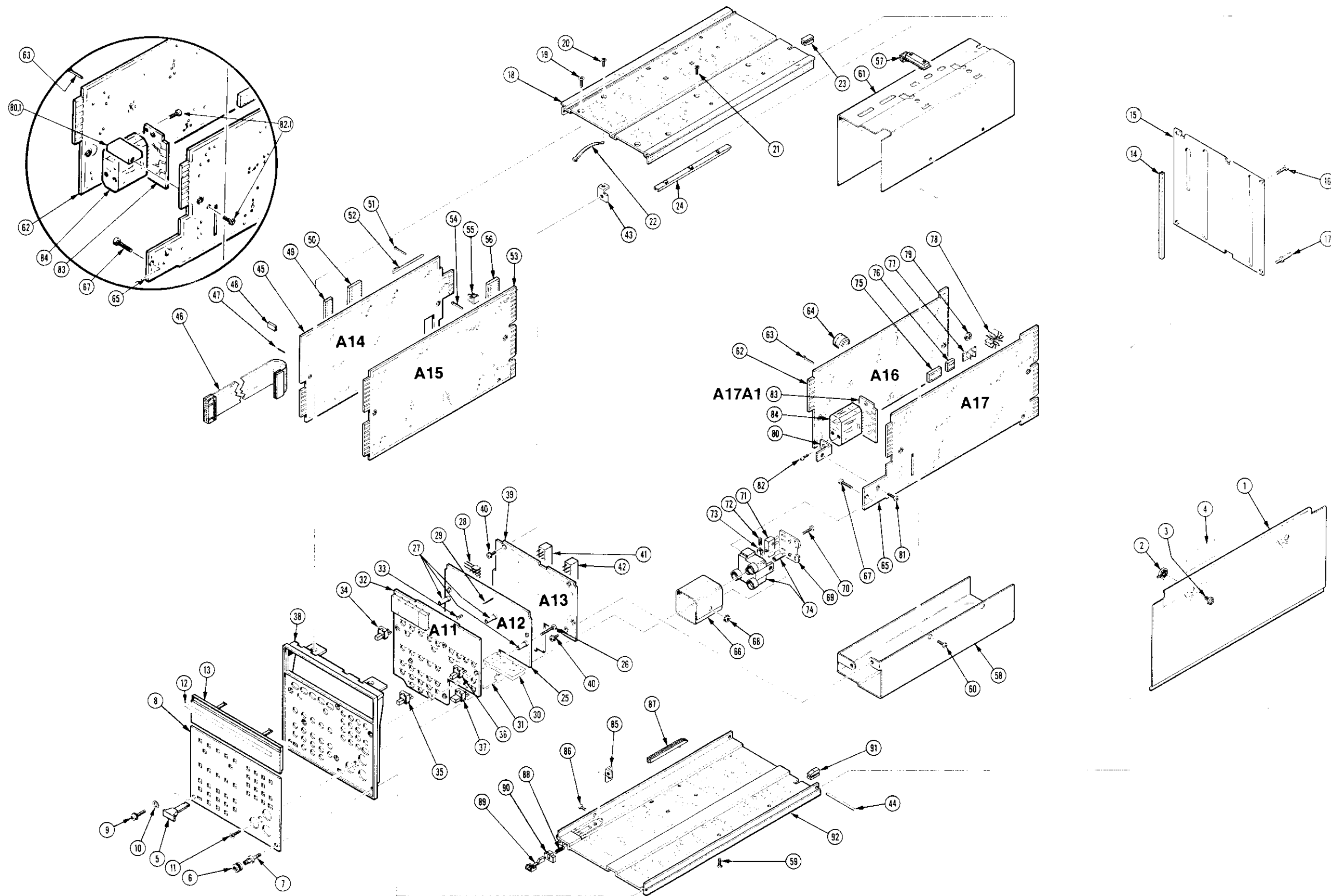

FIG. 1 EXPLODED

REV JUN 1986

DM 5010

?

?

REPLACEABLE MECHANICAL PARTS

PARTS ORDERING INFORMATION

Replacement parts are available from or through your local Tektronix, Inc. Field Office or representative.

Changes to Tektronix instruments are sometimes made to accommodate improved components as they become available, and to give you the benefit of the latest circuit improvements developed in our engineering department. It is therefore important, when ordering parts, to include the following information in your order: Part number, instrument type or number, serial number, and modification number if applicable.

If a part you have ordered has been replaced with a new or improved part, your local Tektronix, Inc. Field Office or representative will contact you concerning any change in part number.

Change information, if any, is located at the rear of this manual.

SPECIAL NOTES AND SYMBOLS

X000 Part first added at this serial number
00X Part removed after this serial number

FIGURE AND INDEX NUMBERS

Items in this section are referenced by figure and index numbers to the illustrations.

INDENTATION SYSTEM

This mechanical parts list is indented to indicate item relationships. Following is an example of the indentation system used in the description column.

```

1 2 3 4 5           Name & Description
Assembly and/or Component
Attaching parts for Assembly and/or Component
-----
Detail Part of Assembly and/or Component
Attaching parts for Detail Part
-----
Parts of Detail Part
Attaching parts for Parts of Detail Part
-----

```

Attaching Parts always appear in the same indentation as the item it mounts, while the detail parts are indented to the right. Indented items are part of, and included with, the next higher indentation. The separation symbol "----" indicates the end of attaching parts.

Attaching parts must be purchased separately, unless otherwise specified.

ITEM NAME

In the Parts List, an Item Name is separated from the description by a colon (:). Because of space limitations, an Item Name may sometimes appear as incomplete. For further Item Name identification, the U.S. Federal Cataloging Handbook H6-1 can be utilized where possible.

ABBREVIATIONS

| | | | | | | | |
|-------|--------------------|---------|-----------------------|----------|----------------------|---------|-----------------|
| ~ | INCH | ELCTRN | ELECTRON | IN | INCH | SE | SINGLE END |
| # | NUMBER SIZE | ELEC | ELECTRICAL | INCAND | INCANDESCENT | SECT | SECTION |
| ACTR | ACTUATOR | ELCTLT | ELECTROLYTIC | INSUL | INSULATOR | SEMICON | SEMICONDUCTOR |
| ADPTR | ADAPTER | ELEM | ELEMENT | INTL | INTERNAL | SHLD | SHIELD |
| ALIGN | ALIGNMENT | EPL | ELECTRICAL PARTS LIST | LPHLDR | LAMPHOLDER | SHLDR | SHOULDERED |
| AL | ALUMINUM | EQPT | EQUIPMENT | MACH | MACHINE | SKT | SOCKET |
| ASSEM | ASSEMBLED | EXT | EXTERNAL | MECH | MECHANICAL | SL | SLIDE |
| ASSY | ASSEMBLY | FIL | FILLISTER HEAD | MTG | MOUNTING | SLFLKG | SELF-LOCKING |
| ATTEN | ATTENUATOR | FLEX | FLEXIBLE | NIP | NIPPLE | SLVG | SLEEVING |
| AWG | AMERICAN WIRE GAGE | FLH | FLAT HEAD | NON WIRE | NOT WIRE WOUND | SPR | SPRING |
| BD | BOARD | FLTR | FILTER | OBD | ORDER BY DESCRIPTION | SQ | SQUARE |
| BRKT | BRACKET | FR | FRAME or FRONT | OD | OUTSIDE DIAMETER | SST | STAINLESS STEEL |
| BRS | BRASS | FSTNR | FASTENER | OVH | OVAL HEAD | STL | STEEL |
| BRZ | BRONZE | FT | FOOT | PH BRZ | PHOSPHOR BRONZE | SW | SWITCH |
| BSHG | BUSHING | FXD | FIXED | PL | PLAIN or PLATE | T | TUBE |
| CAB | CABINET | GSKT | GASKET | PLSTC | PLASTIC | TERM | TERMINAL |
| CAP | CAPACITOR | HDL | HANDLE | PN | PART NUMBER | THD | THREAD |
| CER | CERAMIC | HEX | HEXAGON | PNH | PAN HEAD | THK | THICK |
| CHAS | CHASSIS | HEX HD | HEXAGONAL HEAD | PWR | POWER | TNSN | TENSION |
| CKT | CIRCUIT | HEX SOC | HEXAGONAL SOCKET | RCPT | RECEPTACLE | TPG | TAPPING |
| COMP | COMPOSITION | HLCPS | HELICAL COMPRESSION | RES | RESISTOR | TRH | TRUSS HEAD |
| CONN | CONNECTOR | HLEXT | HELICAL EXTENSION | RGD | RIGID | V | VOLTAGE |
| COV | COVER | HV | HIGH VOLTAGE | RLF | RELIEF | VAR | VARIABLE |
| CPLG | COUPLING | IC | INTEGRATED CIRCUIT | RTNR | RETAINER | W/ | WITH |
| CRT | CATHODE RAY TUBE | ID | INSIDE DIAMETER | SCH | SOCKET HEAD | WSHR | WASHER |
| DEG | DEGREE | IDENT | IDENTIFICATION | SCOPE | OSCILLOSCOPE | XFMR | TRANSFORMER |
| DWR | DRAWER | IMPLR | IMPELLER | SCR | SCREW | XSTR | TRANSISTOR |

CROSS INDEX - MFR. CODE NUMBER TO MANUFACTURER

| Mfr. Code | Manufacturer | Address | City, State, Zip Code |
|-----------|--|--|----------------------------|
| 01536 | TEXTRON INC CAMCAR DIV SEMS PRODUCTS UNIT | 1818 CHRISTINA ST | ROCKFORD IL 61108 |
| 05820 | EG AND G MAKEFIELD ENGINEERING | 60 AUDUBON RD | MAKEFIELD MA 01880 |
| 06383 | PANDUIT CORP | 17301 RIDGELAND | TINLEY PARK IL 60477 |
| 09922 | BURNODY CORP | RICHARDS AVE | NORMALK CT 06852 |
| 13103 | THERMALLOY CO INC | 2021 W VALLEY VIEW LANE P O BOX 34829 | DALLAS TX 75234 |
| 22526 | DU PONT E I DE NEMOURS AND CO INC DU PONT CONNECTOR SYSTEMS | 30 HUNTER LANE | CAMP HILL PA 17011 |
| 71785 | TRM INC TRM CINCH CONNECTORS | 1501 MORSE AVE | ELK GROVE VILLAGE IL 60007 |
| 72228 | AMCA INTERNATIONAL CORP CONTINENTAL SCREW CO DIV | 459 MT PLEASANT | NEW BEDFORD MA 02742 |
| 75915 | LITTELFUSE INC | 800 E NORTHWEST HWY | DES PLAINES IL 60016 |
| 78189 | ILLINOIS TOOL WORKS INC SHAKEPROOF DIVISION | ST CHARLES ROAD | ELGIN IL 60120 |
| 80009 | TEKTRONIX INC | 4900 S W GRIFFITH DR P O BOX 500 | BEAVERTON OR 97077 |
| 83385 | MICRODOT MANUFACTURING INC GREER-CENTRAL DIV | 3221 W BIG BEAVER RD | TROY MI 48098 |
| 83486 | ELCO INDUSTRIES INC | 1101 SAMUELSON RD | ROCKFORD IL 61101 |
| 93907 | TEXTRON INC CAMCAR DIV | 600 18TH AVE | ROCKFORD IL 61101 |
| 98978 | INTERNATIONAL ELECTRONIC RESEARCH CORP SUB OF DYNAMICS CORP OF AMERICA | 135 W MAGNOLIA BLVD | BURBANK CA 91502 |
| TK0435 | LEMIS SCREW CO | 4114 S PEDRIA | CHICAGO IL 60609 |
| TK0502 | CONNOR SPRING AND MFG CO | 9400 NE COLFAX | PORTLAND OR 97220 |

| Fig. & Index No. | Tektronix Part No. | Serial/Assembly No. | | Qty | 12345 | Name & Description | Mfr. | |
|------------------------|-----------------------|---------------------|--------|-----|-------|--|--------|----------------|
| | | Effective | Dscont | | | | Code | Mfr. Part No. |
| 1-1 | 337-2807-00 | | | 2 | | SHIELD, ELEC:SIDE, PLUG-IN UNIT | 80009 | 337-2807-00 |
| -2 | 105-0932-00 | | | 4 | | LATCH, PANEL:SIDE | 80009 | 105-0932-00 |
| -3 | 214-3364-00 | | | 4 | | FASTENER, LATCH:ACETAL, SIL GRAY | 80009 | 214-3364-00 |
| -4 | 334-4460-00 | | | 2 | | MARKER, IDENT:MKD GPIB ADDRESS SWITCH | 80009 | 334-4460-00 |
| -5 | 366-1851-01 | | | 1 | | KNOB, LATCH:IVORY GY, 0.625 X 0.25 X 1.09 | 80009 | 366-1851-01 |
| -6 | 220-0633-00 | | | 1 | | NUT, PLAIN, KNURL:0.25-28 X 0.375 OD, BRS NP | 80009 | 220-0633-00 |
| -7 | 355-0170-00 | | | 1 | | STUD, SHLDR&STEP:BINDING POST | 80009 | 355-0170-00 |
| -8 | 333-2736-00 | | | 1 | | PANEL, FRONT: (ATTACHING PARTS) | 80009 | 333-2736-00 |
| -9 | 213-0875-00 | | | 1 | | SCR, ASSEM MSHR:6-32 X 0.5, TAPTITE, PNH, STL | 83486 | ORDER BY DESCR |
| -10 | 210-1365-00 | | | 2 | | WASHER, FLAT:0.141 ID X 0.266 OD X 0.5, AL | 80009 | 210-1365-00 |
| -11 | 211-0537-00 | | | 1 | | SCREW, MACHINE:6-32 X 0.375, TRH, STL (END ATTACHING PARTS) | TK0435 | ORDER BY DESCR |
| -12 | 334-4032-00 | | | 1 | | MARKER, IDENT:MKD DMS10P PROGRAMMABLE | 80009 | 334-4032-00 |
| -13 | 378-0159-04 | | | 1 | | LENS, LED DSPL:RED W/MARKING | 80009 | 378-0159-04 |
| -14 | 255-0581-00 | | | AR | | PLASTIC CHANNEL:0.156 X 0.156, POLYETHYLENE | 80009 | 255-0581-00 |
| -15 | 333-2822-00 | | | 1 | | PANEL, REAR: (ATTACHING PARTS) | 80009 | 333-2822-00 |
| -16 | 213-0868-00 | | | 2 | | SCREW, TPG, TF:6-32 X 0.375 L, FILH, STL | 93907 | ORDER BY DESCR |
| -17 | 386-3657-01 | | | 2 | | SUPPORT, PLUG-IN: (END ATTACHING PARTS) | 93907 | ORDER BY DESCR |
| -18 | 426-1799-00 | | | 1 | | FR SECT, PLUG-IN:TOP (ATTACHING PARTS) | 80009 | 426-1799-00 |
| -19 | 211-0541-00 | | | 2 | | SCREW, MACHINE:6-32 X 0.25, FLH, 100 DEG, STL | TK0435 | ORDER BY DESCR |
| -20 | 211-0105-00 | | | 2 | | SCREW, MACHINE:4-40 X 0.188, FLH, 100 DEG | TK0435 | ORDER BY DESCR |
| -21 | 213-0815-00 | | | 2 | | SCREW, TPG, TR:4-20, 0.188L, PLASTITE, FLH, STL (END ATTACHING PARTS) | 72228 | ORDER BY DESCR |
| -22 | 214-1061-00 | | | 1 | | CONTACT, ELEC:GROUNDING, CU BE | 80009 | 214-1061-00 |
| -23 | 214-3089-00 | | | 1 | | LOCKOUT, PLUG-IN:PLASTIC | 80009 | 214-3089-00 |
| -24 | 351-0604-00 | | | 2 | | GUIDE, CKT BOARD:PLASTIC | 80009 | 351-0604-00 |
| -25 | ----- | | | 1 | | CKT BOARD ASSY:FP DRIVER(SEE A12 REPL) (ATTACHING PARTS) | | |
| -26 | 211-0017-00 | | | 5 | | SCREW, MACHINE:4-40 X 0.75, PNH, STL (END ATTACHING PARTS) CKT BOARD ASSY INCLUDES: | 93907 | ORDER BY DESCR |
| -27 | 361-1086-00 | | | 5 | | .SPACER, SLEEVE:0.65 L X 0.125 ID, BRS | 80009 | 361-1086-00 |
| -28 | ----- | | | 1 | | CONN, RCPT, ELEC:(SEE A12J1820 REPL) | | |
| -29 | ----- | | | 29 | | CONTACT, ELEC:(SEE A12P1120, P1300, P1320, P1400 REPL) | | |
| -30 | 342-0584-00 | | | 1 | | INSULATOR, PLATE:SHIELD, POLYESTER | 80009 | 342-0584-00 |
| -31 | 337-2940-00 | | | 1 | | SHIELD, ELEC:CIRCUIT BOARD | 80009 | 337-2940-00 |
| -32 | ----- | | | 1 | | CKT BOARD ASSY:FRONT PANEL(SEE A11 REPL) | | |
| -33 | ----- | | | 29 | | .SOCKET, PIN TERM:(SEE A11J1120, J1300, J1320, J1400 REPL) | | |
| -34 | ----- | | | 21 | | .SWITCH, PB ASSY:(SEE A11S1025, S1035, S1037, S1039, S1139, S1232, S1235, S1239, S1310, S1315, S1320, S1325, S1410, S1412, S1415, S1417, S1420, S1422, S1425, S1427, S1520 REPL) | | |
| -35 | ----- | | | 17 | | .SWITCH, PB ASSY:(SEE A11S1010, S1015, S1020, S1135, S1030, S1032, S1110, S1115, S1120, S1130, S1210, S1215, S1217, S1220, S1225, S1230, S1237REPL) | | |
| -36 | ----- | | | 1 | | .SWITCH, PB ASSY:(SEE A11S1510 REPL) | | |
| -37 | ----- | | | 1 | | .SWITCH, PB ASSY:(SEE A11S1525 REPL) | | |
| -38 | 386-4569-00 | | | 1 | | SUBPANEL, FRONT: | 80009 | 386-4569-00 |
| -39 | ----- | | | 1 | | CKT BOARD ASSY:MAIN INTERCONNECT(SEE A13 RE (ATTACHING PARTS) | | |
| -40 | 211-0661-00 | | | 5 | | SCR, ASSEM MSHR:4-40 X 0.25, PNH, STL, P0Z (END ATTACHING PARTS) CKT BOARD ASSY INCLUDES: | 01536 | 821-01655-024 |
| -41 | ----- | | | 2 | | CONN, RCPT, ELEC:(SEE A13J1731, J1733 REPL) | | |
| -42 | ----- | | | 3 | | .CONN, RCPT, ELEC:(SEE A13J1701, J1711, J1718REPL) | | |
| -43 | 407-2555-00 | | | 2 | | BRACKET, ANGLE:CIRCUIT BOARD, AL | 80009 | 407-2555-00 |
| -44 | 343-0946-00 | | | 1 | | RETAINER, CKT BD:0.123 OD X 4.99 L M/5-40 TH D ONE END | 80009 | 343-0946-00 |

Replaceable Mechanical Parts - DM 5010

| Fig. & Index No. | Tektronix Part No. | Serial/Assembly No. Effective | Dscont | Qty | 12345 Name & Description | Mfr. Code | Mfr. Part No. |
|------------------|--------------------|-------------------------------|---------|-----|--|-----------|---------------|
| 1-45 | ----- | | | 1 | CKT BOARD ASSY:PROCESSOR(SEE A14 REPL) | | |
| -46 | 175-3884-00 | | | 1 | .CA ASSY, SP, ELEC:20,28 AWG,6.65 L,RTBBON | 80009 | 175-3884-00 |
| -47 | 131-0993-00 | | | 4 | .BUS, CONDUCTOR:SHUNT ASSEMBLY, BLACK | 22526 | 65474-005 |
| -48 | ----- | | | 12 | .TERMINAL, PIN:(SEE A14J1132, J1425, J1721, J1723 REPL) | | |
| -49 | 136-0751-00 | | | 4 | .SKT, PL-IN ELEK:MICROCKT, 24 PIN | 09922 | D1LB24P108 |
| -50 | 136-0757-00 | | | 3 | .SKT, PL-IN ELEK:MICROCIRCUIT, 40 DIP | 09922 | D1LB40P-108 |
| -51 | ----- | | | 5 | .TERM, TEST POINT:(SEE A14TP1531, TP1533, TP1535, TP1621, TP1625 REPL) | | |
| -52 | 343-0549-00 | | | 2 | .STRAP, TIEDOWN, E:0.091 M X 4.0 L, ZYTEL | 06383 | PLT1M |
| -53 | ----- | | | 1 | CKT BOARD ASSY:CPU(SEE A15 REPL) | | |
| -54 | ----- | | | 1 | .TERM, TEST POINT:(SEE A15TP1421 REPL) | | |
| -55 | 344-0326-00 | | | 4 | .CLIP, ELECTRICAL:FUSE, BRASS | 75915 | 102071 |
| -56 | 136-0751-00 | | | 1 | .SKT, PL-IN ELEK:MICROCKT, 24 PIN | 09922 | D1LB24P108 |
| -57 | 351-0654-00 | | | 4 | GUIDE, CKT BOARD:PLASTIC, 1.45 L | 80009 | 351-0654-00 |
| -58 | 337-2856-00 | | | 1 | SHIELD, ELEC:CONVERTER, BOTTOM (ATTACHING PARTS) | 80009 | 337-2856-00 |
| -59 | 213-0815-00 | | | 2 | SCREW, TPG, TR:4-20, 0.188L, PLASTITE, FLH, STL | 72228 | ORDER BY DESC |
| -60 | 211-0007-00 | | | 4 | SCREW, MACHINE:4-40 X 0.188, PNH, STL (END ATTACHING PARTS) | TK0435 | ORDER BY DESC |
| -61 | 337-2857-00 | | | 1 | SHIELD, ELEC:CONVERTER, TOP | 80009 | 337-2857-00 |
| -62 | ----- | | | 1 | CKT BOARD ASSY:RMS(SEE A16 REPL) | | |
| -63 | ----- | | | 3 | .TERM, TEST POINT:(SEE A16TP1201, TP1503, TP1701 REPL) | | |
| -64 | 136-0241-00 | | | 1 | .SKT, PL-IN ELEK:MICROCIRCUIT, 10 CONT, PCB MT | 71785 | 133-99-12-064 |
| | 672-1015-00 | | | 1 | CIRCUIT BD ASSY:RELAY | 80009 | 672-1015-00 |
| -65 | ----- | | | 1 | .CKT BOARD ASSY:ADC(SEE A17 REPL) | | |
| -66 | 337-2930-00 | | | 1 | ..SHIELD, ELEC:GUARD, FRONT (ATTACHING PARTS) | 80009 | 337-2930-00 |
| -67 | 211-0012-00 | | | 1 | ..SCREW, MACHINE:4-40 X 0.375, PNH, STL | TK0435 | ORDER BY DESC |
| -68 | 210-0586-00 | | | 1 | ..NUT, PL, ASSEM MA:4-40 X 0.25, STL CD PL (END ATTACHING PARTS) | 78189 | 211-041800-00 |
| -69 | 343-0944-00 | | | 1 | ..RETAINER, CONT:SWITCH, FIBER SHEET (ATTACHING PARTS) | 80009 | 343-0944-00 |
| -70 | 213-0088-00 | | | 1 | ..SCREW, TPG, TF:4-24 X 0.25, TYPE B, PNH (END ATTACHING PARTS) | 83385 | ORDER BY DESC |
| -71 | ----- | | | 1 | ..SWITCH, PUSH:(SEE A17S1731 REPL) | | |
| -72 | 214-1157-00 | | | 1 | ..SPRING, HLCPS:0.137 00 X 0.36 L, MUM | TK0502 | ORDER BY DESC |
| -73 | 105-0875-00 | B010100 | B020979 | 1 | ..ACTR, PUSH SM:PLASTIC | 80009 | 105-0875-00 |
| | 105-0875-01 | B020980 | | 1 | ..ACTR, PUSH SM:PLASTIC | 80009 | 105-0875-01 |
| -74 | 352-0620-00 | | | 1 | ..HOLDER, CONT/SM:BANANA JACK, PLASTIC | 80009 | 352-0620-00 |
| -75 | 136-0729-00 | | | 1 | .SKT, PL-IN ELEK:MICROCKT, 16 CONTACT | 09922 | D1LB16P-108T |
| -76 | 136-0727-00 | | | 1 | .SKT, PL-IN ELEK:MICROCKT, 8 CONTACT | 09922 | D1LB8P-108 |
| -77 | 214-2496-00 | | | 4 | ..HEAT SINK, XSTR:TO-5, AL | 98978 | 7-175-8A |
| -78 | 214-1291-00 | | | 1 | ..HEAT SINK, XSTR:TO-5, SIL BRZ PTD BLACK | 05820 | 20758 |
| -79 | 342-0324-00 | | | 5 | ..INSULATOR, DISK:TRANSISTOR, NYLON | 13103 | 7717-5N-BLUE |
| -80 | 407-2783-00 | B010100 | B021903 | 1 | ..BRACKET, CMPNT:RELAY | 80009 | 407-2783-00 |
| -80.1 | 407-3431-00 | B021904 | | 1 | ..BRACKET, RELAY:PLASTIC (ATTACHING PARTS) | 80009 | 407-3431-00 |
| -81 | 211-0008-00 | B010100 | B021903 | 1 | ..SCREW, MACHINE:4-40 X 0.25, PNH, STL | 93907 | ORDER BY DESC |
| -82 | 211-0698-00 | B010100 | B021903 | 1 | ..SCREW, MACHINE:3-48 X 0.188, PNH, STL | TK0435 | ORDER BY DESC |
| -82.1 | 211-0008-00 | B021904 | | 2 | ..SCREW, MACHINE:4-40 X 0.25, PNH, STL (END ATTACHING PARTS) | 93907 | ORDER BY DESC |
| -83 | ----- | | | 1 | .CKT BOARD ASSY:RELAY(SEE A17A1 REPL) | | |
| -84 | ----- | | | 1 | ..RELAY, ARMATURE:(PART OF A17) | | |
| -85 | 407-2559-00 | | | 1 | BRACKET, ANGLE:INTERFACE CKT BD, AL (ATTACHING PARTS) | 80009 | 407-2559-00 |
| -86 | 211-0105-00 | | | 1 | SCREW, MACHINE:4-40 X 0.188, FLH, 100 DEG (END ATTACHING PARTS) | TK0435 | ORDER BY DESC |
| -87 | 351-0653-00 | | | 2 | GUIDE, CKT BOARD:PLASTIC, 2.226 L | 80009 | 351-0653-00 |
| -88 | 214-3143-00 | | | 1 | SPRING, HLEXT:0.125 00 X 0.545 L, XLOOP | 80009 | 214-3143-00 |
| -89 | 105-0866-00 | | | 1 | LATCH, RETAINING:SAFETY | 80009 | 105-0866-00 |
| -90 | 105-0865-00 | | | 1 | BAR, LATCH RLSE: | 80009 | 105-0865-00 |
| -91 | 214-3089-00 | | | 1 | LOCKOUT, PLUG-IN:PLASTIC | 80009 | 214-3089-00 |
| -92 | 426-1800-01 | | | 1 | FR SECT, PLUG-IN:M/SPRING & EYELET | 80009 | 426-1800-01 |

| Fig. & Index No. | Tektronix Part No. | Serial/Assembly No. | | Qty | 12345 | Name & Description | Mfr. | |
|------------------------|-----------------------|---------------------|--------|-----|-------|---------------------------------|-------|---------------|
| | | Effective | Dscont | | | | Code | Mfr. Part No. |
| 1- | | | | | | STANDARD ACCESSORIES | | |
| | 003-0120-00 | | | 1 | | LEAD, TEST: ONE PAIR | 80009 | 003-0120-00 |
| | 070-2994-01 | | | 1 | | MANUAL, TECH: INSTR, DM5010 | 80009 | 070-2994-01 |
| | 070-3542-00 | | | 1 | | MANUAL, TECH: REFERENCE, DM5010 | 80009 | 070-3542-00 |

