

# Programmer Manual

**Tektronix**

**CTS 750  
SDH Test Set  
070-8925-03**

This document applies to firmware version 1.40  
and above.

Copyright © Tektronix, Inc. All rights reserved. Licensed software products are owned by Tektronix or its suppliers and are protected by United States copyright laws and international treaty provisions.

Use, duplication, or disclosure by the Government is subject to restrictions as set forth in subparagraph (c)(1)(ii) of the Rights in Technical Data and Computer Software clause at DFARS 252.227-7013, or subparagraphs (c)(1) and (2) of the Commercial Computer Software – Restricted Rights clause at FAR 52.227-19, as applicable.

Tektronix products are covered by U.S. and foreign patents, issued and pending. Information in this publication supercedes that in all previously published material. Specifications and price change privileges reserved.

Printed in the U.S.A.

Tektronix, Inc., P.O. Box 1000, Wilsonville, OR 97070-1000

TEKTRONIX and TEK are registered trademarks of Tektronix, Inc.

TEKTRONIX  
CORPORATION  
2200

## WARRANTY

Tektronix warrants that this product will be free from defects in materials and workmanship for a period of three (3) years from the date of shipment. If any such product proves defective during this warranty period, Tektronix, at its option, either will repair the defective product without charge for parts and labor, or will provide a replacement in exchange for the defective product.

In order to obtain service under this warranty, Customer must notify Tektronix of the defect before the expiration of the warranty period and make suitable arrangements for the performance of service. Customer shall be responsible for packaging and shipping the defective product to the service center designated by Tektronix, with shipping charges prepaid. Tektronix shall pay for the return of the product to Customer if the shipment is to a location within the country in which the Tektronix service center is located. Customer shall be responsible for paying all shipping charges, duties, taxes, and any other charges for products returned to any other locations.

This warranty shall not apply to any defect, failure or damage caused by improper use or improper or inadequate maintenance and care. Tektronix shall not be obligated to furnish service under this warranty a) to repair damage resulting from attempts by personnel other than Tektronix representatives to install, repair or service the product; b) to repair damage resulting from improper use or connection to incompatible equipment; or c) to service a product that has been modified or integrated with other products when the effect of such modification or integration increases the time or difficulty of servicing the product.

**THIS WARRANTY IS GIVEN BY TEKTRONIX WITH RESPECT TO THIS PRODUCT IN LIEU OF ANY OTHER WARRANTIES, EXPRESSED OR IMPLIED. TEKTRONIX AND ITS VENDORS DISCLAIM ANY IMPLIED WARRANTIES OF MERCHANTABILITY OR FITNESS FOR A PARTICULAR PURPOSE. TEKTRONIX' RESPONSIBILITY TO REPAIR OR REPLACE DEFECTIVE PRODUCTS IS THE SOLE AND EXCLUSIVE REMEDY PROVIDED TO THE CUSTOMER FOR BREACH OF THIS WARRANTY. TEKTRONIX AND ITS VENDORS WILL NOT BE LIABLE FOR ANY INDIRECT, SPECIAL, INCIDENTAL, OR CONSEQUENTIAL DAMAGES IRRESPECTIVE OF WHETHER TEKTRONIX OR THE VENDOR HAS ADVANCE NOTICE OF THE POSSIBILITY OF SUCH DAMAGES.**

e-1  
01-1  
**81-1**  
81-1  
81-1  
41-1  
41-1  
71-1  
71-1  
71-1  
71-1  
81-1  
81-1  
81-1  
81-1  
81-1  
91-1

# Table of Contents

## Getting Started

<b>Preface</b> .....	<b>xi</b>
About This Manual .....	xi
Conventions .....	xii
Related Manuals .....	xii
<b>Setting Up for Remote Communication</b> .....	<b>1-1</b>
GPIB Connection .....	1-1
GPIB Parameter Setup .....	1-2
GPIB Connection Test .....	1-3
RS-232 Connection .....	1-3
RS-232 Parameter Setup .....	1-4
RS-232 Connection Test .....	1-5
<b>Programming Model</b> .....	<b>1-7</b>
Functional Blocks .....	1-7
Transmitter .....	1-7
Receiver .....	1-7
Modes of Operation .....	1-7
Normal Mode .....	1-7
Through Mode .....	1-8
Information Storage in the Instrument .....	1-8
Storage of Instrument Setups .....	1-8
Storage of Pass/Fail Tests .....	1-9
Storage of Test Results .....	1-10
<b>Examples of Command Usage</b> .....	<b>1-13</b>
Generating Signals .....	1-13
Generating Signals in Normal Mode .....	1-13
Generating Signals in Through Mode .....	1-14
Generating Modified Signals .....	1-14
Receiving Signals .....	1-17
Receiving a Signal Using a Manual Setup .....	1-17
Receiving a Signal Using Autoscan .....	1-17
Checking the Physical Status of a Signal .....	1-17
Checking Signal Status .....	1-18
Dropping the Overhead .....	1-18
Viewing the Overhead .....	1-18
SDH Signal Testing .....	1-18
Taking BER Measurements .....	1-18
Measuring Continuous Pointer Adjustments .....	1-19

Tributary Signal Testing .....	1-20
CTS 750 as a Stand-Alone Tributary Test Set .....	1-20
Testing the SDH Tributary Payload Mapping .....	1-21
Testing the Mapping Capability of a Network Element .....	1-23
Testing the Demapping Capability of a Network Element .....	1-24
Testing the External Connection of an Add/Drop/Test Set .....	1-25

## Syntax and Commands

<b>Syntax</b> .....	<b>2-1</b>
SCPI Commands and Queries .....	2-1
Creating Commands .....	2-1
Creating Queries .....	2-2
Parameter Types .....	2-2
Abbreviating Commands, Queries, and Parameters .....	2-3
Controlling Responses to Queries .....	2-4
Chaining Commands and Queries .....	2-4
General Rules .....	2-5
IEEE 488.2 Common Commands .....	2-6
Description .....	2-6
Command and Query Structure .....	2-6
<b>Functional Command Groups</b> .....	<b>2-7</b>
<b>Transmit Commands</b> .....	<b>2-13</b>
OUTPUT1 Subsystem .....	2-14
OUTPUT2 Subsystem .....	2-17
OUTPUT3 Subsystem .....	2-19
SOURCE:CLOCK Subsystem .....	2-20
SOURCE:DATA:TELEcom Subsystem .....	2-25
SOURCE:DATA:TELEcom:OVERhead and POVerhead Subsystem .....	2-31
SOURCE:DATA:TELEcom:ERRor, ALARm, and FAILure Subsystem .....	2-41
SOURCE:DATA:TELEcom:POINter Subsystem .....	2-47
SOURCE:DATA:TELEcom:TRIButary Subsystem .....	2-63
SOURCE:DATA:TELEcom:TRIButary:ERRor, ALARm, FAILure Subsystem .....	2-73
SOURCE:DATA:TELEcom:TRIButary:POINter Subsystem .....	2-76
SOURCE:DATA:TELEcom:JITter Subsystem .....	2-92
<b>Receive Commands</b> .....	<b>2-99</b>
INPUT1 Subsystem .....	2-100
INPUT2 Subsystem .....	2-105
INPUT3 Subsystem .....	2-108
SENSE:DATA:TELEcom Subsystem .....	2-111
SENSE:DATA:TELEcom:TEST Subsystem .....	2-118
SENSE:DATA:TELEcom:TEST:JITter Subsystem .....	2-124
SENSE:DATA:TELEcom:OVERhead and POVerhead Subsystem .....	2-163
SENSE:DATA:TELEcom:MEASure Subsystem .....	2-169
SENSE:DATA:TELEcom:MEASure:STESts Subsystem .....	2-187
SENSE:DATA:TELEcom:MEASure:JITter Subsystem .....	2-195
SENSE:DATA:TELEcom:MEASure:WANDer Subsystem .....	2-211
SENSE:DATA:TELEcom:MEASure:TRIButary Subsystem .....	2-217
SENSE:DATA:TELEcom:AUTOscan Subsystem .....	2-228
SENSE:DATA:TELEcom:TRIButary Subsystem .....	2-229
SENSE:DATA:TELEcom:JITter Subsystem .....	2-241

6-2  
 8-5  
 7-3  
 7-4  
 8-  
 1-4  
 1-5  
 1-6  
 1-6

<b>Transmitter/Receiver Setup Commands</b> .....	<b>2-251</b>
INSTRument Subsystem .....	2-251
<b>Trigger and Capture Commands</b> .....	<b>2-253</b>
TRIGger Subsystem .....	2-253
<b>Input/Output Commands</b> .....	<b>2-257</b>
MMEMory Subsystem .....	2-257
MMEMory:JITter Subsystem .....	2-265
DISPlay Subsystem .....	2-275
HCOPY Subsystem .....	2-276
SYSTem:COMMunicate:SERial Subsystem .....	2-280
<b>Instrument Control Commands</b> .....	<b>2-289</b>
SYSTem Subsystem .....	2-289
<b>Diagnostic and Calibrate Commands</b> .....	<b>2-301</b>
DIAGNostic Subsystem .....	2-301
CALibrate Subsystem .....	2-308
<b>Common Commands</b> .....	<b>2-311</b>

## Status and Events

<b>Status and Events</b> .....	<b>3-1</b>
Status and Event Reporting System .....	3-1
Status Byte Register .....	3-1
Service Request Enable Register .....	3-2
Standard Event Status Register .....	3-3
Event Status Enable Register .....	3-4
The Output Queue .....	3-5
The System Error and Event Queue .....	3-5
Status and Event Reporting Process .....	3-6
Synchronization Methods .....	3-7
Using the *OPC? Query .....	3-7
Messages .....	3-8

## Examples

<b>Examples</b> .....	<b>4-1</b>
-----------------------	------------

## Appendices

<b>Appendix A: ASCII &amp; GPIB Code Chart</b> .....	<b>A-1</b>
<b>Appendix B: Commands and Queries that set OPC Bit</b> .....	<b>B-1</b>
<b>Appendix C: Commands Returned by *LRN?</b> .....	<b>C-1</b>
<b>Appendix D: Default Parameter Values After *RST</b> .....	<b>D-1</b>

## Glossary and Index

## List of Figures

<b>Figure 1–1: Rear-panel communication ports</b> .....	1–2
<b>Figure 1–2: GPIB address in the UTILITY menu</b> .....	1–3
<b>Figure 1–3: Modes of operation</b> .....	1–8
<b>Figure 1–4: How instrument setups are stored</b> .....	1–9
<b>Figure 1–5: How pass/fail tests are stored</b> .....	1–10
<b>Figure 1–6: How test results are stored</b> .....	1–11
<b>Figure 1–7: Setup for the CTS 750 as a stand-alone tributary test set</b> .....	1–20
<b>Figure 1–8: Setup for testing the SDH tributary payload mapping</b> .....	1–22
<b>Figure 1–9: Setup for testing the mapping capability of a network element</b> .....	1–23
<b>Figure 1–10: Setup for testing the demapping capability of a network element</b> .....	1–24
<b>Figure 1–11: Setup for testing the external connection of an Add/Drop/Test set</b> .....	1–25
<b>Figure 2–1: Example of SCPI subsystem hierarchy tree</b> .....	2–1
<b>Figure 2–2: Example of abbreviating a command</b> .....	2–3
<b>Figure 2–3: Example of chaining commands and queries</b> .....	2–4
<b>Figure 2–4: Example of omitting root and lower-level nodes in chained message</b> .....	2–5
<b>Figure 2–5: Example of command listing</b> .....	2–11
<b>Figure 2–6: How to interpret a &lt;decimal value&gt; parameter or response</b> .....	2–12
<b>Figure 2–7: OUTPUT1 subsystem</b> .....	2–14
<b>Figure 2–8: OUTPUT2 subsystem</b> .....	2–17
<b>Figure 2–9: OUTPUT3 subsystem</b> .....	2–19
<b>Figure 2–10: SOURce:CLOCK subsystem</b> .....	2–20
<b>Figure 2–11: SOURce:DATA:TELEcom subsystem</b> .....	2–25
<b>Figure 2–12: SOURce:DATA:TELEcom:OVERhead and POverhead subsystem</b> .....	2–31
<b>Figure 2–13: How to read the overhead default values table</b> .....	2–31
<b>Figure 2–14: SDH Overhead Default Values</b> .....	2–32
<b>Figure 2–15: SOURce:DATA:TELEcom:ERRor, ALARm, and FAILure subsystem</b> .....	2–41
<b>Figure 2–16: SOURce:DATA:TELEcom:POINter subsystem</b> .....	2–47



Figure 2-17: SOURce:DATA:TELEcom:TRIButary subsystem . . . .	2-63
Figure 2-18: SOURce:DATA:TELEcom:TRIButary:ERRor, ALARm, FAILure subsystem . . . . .	2-73
Figure 2-19: SOURce:DATA:TELEcom:TRIButary:POINter subsystem . . . . .	2-76
Figure 2-20: SOURce:DATA:TELEcom:JITter subsystem . . . . .	2-92
Figure 2-21: Jitter/Wander amplitude and frequency limits . . . . .	2-97
Figure 2-22: INPUT1 subsystem . . . . .	2-100
Figure 2-23: INPUT2 subsystem . . . . .	2-105
Figure 2-24: INPUT3 subsystem . . . . .	2-108
Figure 2-25: SENSE:DATA:TELEcom subsystem . . . . .	2-111
Figure 2-26: SENSE:DATA:TELEcom:TEST subsystem . . . . .	2-118
Figure 2-27: SENSE:DATA:TELEcom:TEST:JITter subsystem . . . .	2-124
Figure 2-28: SENSE:DATA:TELEcom:OVERhead and POverhead subsystem . . . . .	2-163
Figure 2-29: SENSE:DATA:TELEcom:MEASure:ANALysis subsystem (SDH) . . . . .	2-169
Figure 2-30: SENSE:DATA:TELEcom:MEASure:ERRor subsystem . . . . .	2-170
Figure 2-31: SENSE:DATA:TELEcom:MEASure:POINter subsystem . . . . .	2-170
Figure 2-32: SENSE:DATA:TELEcom:MEASure:ALARm subsystem . . . . .	2-171
Figure 2-33: SENSE:DATA:TELEcom:MEASure:BUFFer and INFORmation subsystems . . . . .	2-171
Figure 2-34: How to read the syntax tables in the SENSE:DATA :TELEcom:MEASure subsystem section . . . . .	2-173
Figure 2-35: How to read the example tables in the SENSE:DATA :TELEcom:MEASure subsystem section . . . . .	2-174
Figure 2-36: SENSE:DATA:TELEcom:MEASure:STESts subsystem . . . . .	2-187
Figure 2-37: SENSE:DATA:TELEcom:MEASure:JITter subsystem . . . . .	2-195
Figure 2-38: SENSE:DATA:TELEcom:MEASure:WANDer subsystem . . . . .	2-211
Figure 2-39: SENSE:DATA:TELEcom:MEASure:TRIButary :ERRor subsystem (PDH) . . . . .	2-217
Figure 2-40: SENSE:DATA:TELEcom:MEASure:TRIButary :ANALysis subsystem (PDH) . . . . .	2-218
Figure 2-41: SENSE:DATA:TELEcom:MEASure:TRIButary :ALARm subsystems (PDH) . . . . .	2-219

**Figure 2-42: How to read the syntax tables in the SENSE:DATA  
:TELEcom:MEASure:TRIButary subsystem section ..... 2-221**

**Figure 2-43: How to read the example tables in the SENSE:DATA  
:TELEcom:MEASure:TRIButary subsystem section ..... 2-222**

**Figure 2-44: SENSE:DATA:TELEcom:AUTOscan subsystem ..... 2-228**

**Figure 2-45: SENSE:DATA:TELEcom:TRIButary subsystem ..... 2-229**

**Figure 2-46: SENSE:DATA:TELEcom:JITter subsystem ..... 2-241**

**Figure 2-47: INSTRument:COUPling Subsystem ..... 2-251**

**Figure 2-48: TRIGger subsystem ..... 2-253**

**Figure 2-49: MMEMory subsystem ..... 2-257**

**Figure 2-50: MMEMory:JITter subsystem ..... 2-265**

**Figure 2-51: DISPlay subsystem ..... 2-275**

**Figure 2-52: HCOPy subsystem ..... 2-276**

**Figure 2-53: SYSTem:COMMunicate:SERial subsystem ..... 2-280**

**Figure 2-54: SYSTem subsystem ..... 2-289**

**Figure 2-55: DIAGnostic subsystem ..... 2-301**

**Figure 2-56: CALibrate subsystem ..... 2-308**

**Figure 3-1: Status and Event Reporting Process ..... 3-6**

# List of Tables

Table 1–1: Setting GPIB address .....	1–2
Table 1–2: RS-232 pin assignments .....	1–3
Table 1–3: Default RS-232 parameter values .....	1–4
Table 1–4: Setting RS-232 parameters .....	1–5
Table 1–5: RS-232 connection problems .....	1–5
Table 2–1: Parameter types used in syntax descriptions .....	2–2
Table 2–2: Using commands to control the response to a query .....	2–4
Table 2–3: Functional groups and their subsystems .....	2–7
Table 2–4: Interaction Between SOURce:CLOCK Commands .....	2–20
Table 2–5: Error insertion rate limits for SOURce:DATA :TELEcom:ERRor:RATE .....	2–43
Table 2–6: Error insertion rate limits for SOURce:DATA :TELEcom:ERRor:RATE (Add/Drop Test Option Only) .....	2–43
Table 2–7: How error, alarm, and pointer measurements are calculated .....	2–172
Table 2–8: How analysis measurements are calculated .....	2–172
Table 2–9: Value of N for analysis measurements .....	2–173
Table 2–10: Acronyms used in the SENSE:DATA:TELEcom :MEASure queries .....	2–174
Table 2–11: Syntax table for SENSE:DATA:TELEcom:MEASure :ERRor queries .....	2–175
Table 2–12: Syntax table for SENSE:DATA:TELEcom:MEASure :ERRor queries (Add/Drop Test Option Only) .....	2–175
Table 2–13: Example table for SENSE:DATA:TELEcom:MEASure :ERRor queries .....	2–176
Table 2–14: Syntax table for SENSE:DATA:TELEcom:MEASure :ANALysis queries .....	2–176
Table 2–15: Syntax table for SENSE:DATA:TELEcom:MEASure :ANALysis queries (SDH and Add/Drop Test Option Only) .....	2–177
Table 2–16: Example table for SENSE:DATA:TELEcom:MEASure :ANALysis queries (SDH) .....	2–178
Table 2–17: Syntax table for SENSE:DATA:TELEcom:MEASure :ALARm queries .....	2–179
Table 2–18: Syntax table for SENSE:DATA:TELEcom:MEASure :ALARm queries (Add/Drop Test Option Only) .....	2–179

<b>Table 2–19: Example table for SENSE:DATA:TELEcom:MEASure :ALARm queries</b>	<b>2–180</b>
<b>Table 2–20: Syntax table for SENSE:DATA:TELEcom:MEASure :POINter queries</b>	<b>2–180</b>
<b>Table 2–21: Syntax table for SENSE:DATA:TELEcom:MEASure :POINter queries (Add/Drop Test Option Only)</b>	<b>2–181</b>
<b>Table 2–22: Example table for SENSE:DATA:TELEcom:MEASure :POINter queries</b>	<b>2–181</b>
<b>Table 2–23: Syntax table for SENSE:DATA:TELEcom:MEASure :INFORmation queries</b>	<b>2–184</b>
<b>Table 2–24: Example table for SENSE:DATA:TELEcom:MEASure :INFORmation queries</b>	<b>2–185</b>
<b>Table 2–25: How error and alarm measurements are calculated</b>	<b>2–219</b>
<b>Table 2–26: How analysis measurements are calculated</b>	<b>2–220</b>
<b>Table 2–27: Value of N for analysis measurements (PDH)</b>	<b>2–220</b>
<b>Table 2–28: Terms used in the SENSE:DATA: TELEcom:MEASure:TRIButary queries</b>	<b>2–221</b>
<b>Table 2–29: Syntax table for SENSE:DATA:TELEcom:MEASure :TRIButary:ERRor queries (PDH)</b>	<b>2–222</b>
<b>Table 2–30: Example table for SENSE:DATA:TELEcom:MEASure :TRIButary:ERRor queries</b>	<b>2–223</b>
<b>Table 2–31: SENSE:DATA:TELEcom:MEASure:TRIButary :ANALysis:M2100:IN and M2100:OUT Queries (PDH)</b>	<b>2–224</b>
<b>Table 2–32: SENSE:DATA:TELEcom:MEASure:TRIButary :ANALysis:G821 Queries (PDH)</b>	<b>2–225</b>
<b>Table 2–33: Example Table for SENSE:DATA:TELEcom:MEASure :TRIButary:ANALysis Queries (PDH)</b>	<b>2–226</b>
<b>Table 2–34: Syntax Table for SENSE:DATA:TELEcom:MEASure :TRIButary:ALARm Queries</b>	<b>2–226</b>
<b>Table 2–35: Example Table for SENSE:DATA:TELEcom:MEASure :TRIButary:ALARm Queries</b>	<b>2–227</b>
<b>Table 2–36: Parameters Interacting Through Instrument Coupling</b>	<b>2–251</b>
<b>Table 2–37: Commands and Default Values Set by the SYSTem :COMMunicate:SERial:PRESet Command</b>	<b>2–280</b>
<b>Table 3–1: The Status Byte Register</b>	<b>3–2</b>
<b>Table 3–2: The Service Request Enable Register</b>	<b>3–2</b>
<b>Table 3–3: The Standard Event Status Register</b>	<b>3–3</b>
<b>Table 3–4: The Event Status Enable Register</b>	<b>3–4</b>
<b>Table 3–5: Command Error Messages (Bit 5 in Standard Event Status Register)</b>	<b>3–8</b>

<b>Table 3-6: Execution Error Messages (Bit 4 in Standard Event Status Register)</b> .....	<b>3-9</b>
<b>Table 3-7: Device Dependent Error Messages (Bit 3 in Standard Event Status Register)</b> .....	<b>3-10</b>
<b>Table 3-8: System Events</b> .....	<b>3-10</b>
<b>Table 3-9: Execution Warning Messages (Bit 3 in Standard Event Status Register)</b> .....	<b>3-10</b>
<b>Table B-1: Commands and queries that set OPC bit</b> .....	<b>B-1</b>
<b>Table C-1: Commands returned by *LRN?</b> .....	<b>C-1</b>
<b>Table D-1: Default parameter values after *RST</b> .....	<b>D-1</b>



# Preface

The CTS 750 SDH Test Set can be controlled remotely through the use of SCPI-derived commands (Standard Commands for Programmable Instruments) and IEEE 488.2 Common Commands. This manual describes how to use these commands to access information generated by or stored in the instrument.

## About This Manual

The following table shows you where to find information on the more common subjects related to programming your CTS 750.

### Where To Find Information in This Manual

<b>If you want to know:</b>	<b>Look in this part of the manual:</b>
How to set up the instrument for remote communication	<i>Setting Up for Remote Communication</i> starting on page 1-1
How the programming model for this instrument is structured	<i>Programming Model</i> starting on page 1-7
How to perform simple tasks such as generating a normal or modified signal	<i>Examples of Command Usage</i> starting on page 1-13
How the command language syntax is structured	<i>Syntax</i> starting on page 2-1
What the functional command groups are	<i>Functional Command Groups</i> starting on page 2-7
What the commands and queries are	<i>Transmit Commands</i> section on page 2-13 through the <i>Common Commands</i> section
What the error and event messages are	<i>Status and Events</i> section contains the primary error and event messages starting on page 3-8  The commands and queries in <i>Syntax and Commands</i> starting on page 2-13 list the primary and secondary error and event messages for most commands
How to structure a program containing commands and queries	<i>Examples</i> starting on page 4-1
What the default values for the instrument are	<i>Appendix D</i>

## Conventions

The procedures in the *Setting Up for Remote Communication* section that require the use of the front panel are presented in table format. Perform the procedures by reading from left to right in the table (see example below). The word *none* in a cell indicates that no action is required.

Press Menu Button	Select Menu Page	Highlight Parameter	Select Choice
Begin here with Step 1	Step 2	Step 3	Step 4
		Step 5	Step 6
		Step 7	Step 8, CTS 750 instruction is complete

Some procedures require several iterations of highlighting parameters and selecting choices. Some procedures may require more than one menu button or menu page selection as well.

## Related Manuals

The following documents are also available for the CTS 750 SDH Test Set.

- The *CTS 750 User Manual* (Tektronix part number 070-8852-XX) is the primary source of information about how the CTS 750 functions.
- The *CTS 710 SONET Test Set & CTS 750 SDH Test Set Reference* (Tektronix part number 070-8854-XX) provides a quick overview of the instrument programming commands.
- The *CTS 750 SDH Test Set Reference* (Tektronix part number 070-9337-XX) provides a quick overview of the menu structure and alarms.
- The *CTS 710 SONET Test Set & CTS 750 SDH Test Set Service Manual* (Tektronix part number 070-8853-XX) provides information on maintaining and servicing your instrument to the module level.



# Setting Up for Remote Communication

With a computer (controller), you can control the CTS 750 SDH Test Set over GPIB or RS-232. This section shows you how to do the following:

- Connect the instrument to the computer
- Set the communication parameters
- Test the communication

---

**NOTE.** *In order for data communication to take place, the computer should have the proper communication hardware (either GPIB or RS-232) and software drivers already installed. Consult the manufacturer's manuals for detailed information.*

---

## GPIB Connection

To connect the CTS 750 to a computer using a GPIB cable, perform the following procedure:

1. Locate the GPIB port on the rear-panel (see Figure 1-1).
2. Connect one end of the GPIB cable to the CTS 750 and the other end to the computer.
3. Connect both the CTS 750 and the computer to the line voltage.
4. Turn on the instrument.
5. Turn on the computer.

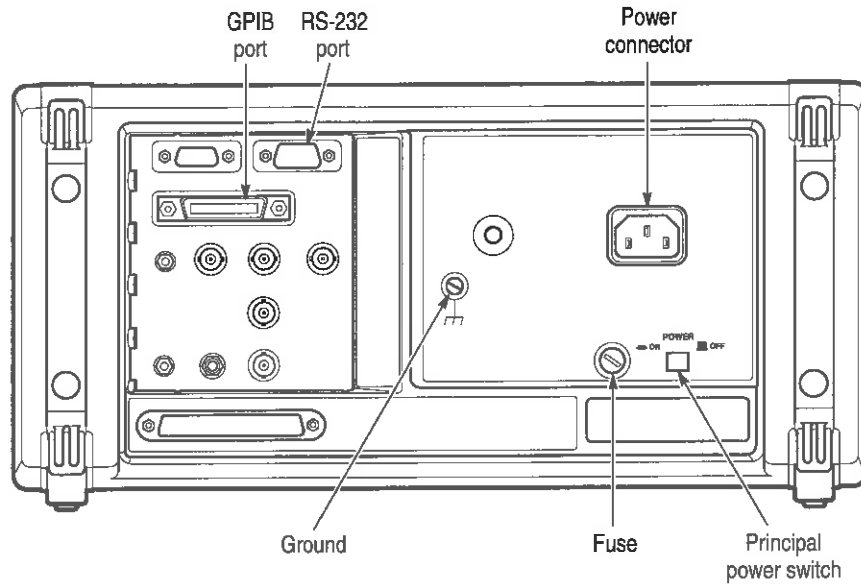

Figure 1-1: Rear-panel communication ports

## GPIB Parameter Setup

The only parameter you may need to set is the GPIB address; the default address set at the factory is 4. To change the GPIB address to other values, perform the steps indicated in Table 1-1.

Table 1-1: Setting GPIB address

Press menu button	Select menu page	Highlight parameter	Select choice
UTILITY	REMOTE CONTROL	GPIB Primary Address	Inc, Dec, or Offline

Figure 1-2 is a display of the UTILITY Menu showing the GPIB Address.

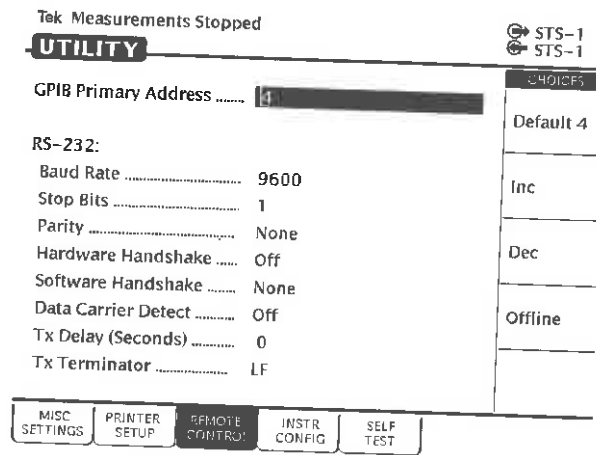

Figure 1-2: GPIB address in the UTILITY menu

## GPIB Connection Test

To test whether the GPIB connection is working, send a GPIB query from the computer. The *Examples* section shows how to send the \*IDN? query command to check the identity of the instrument. The first two terms of the response should be “TEKTRONIX” and “CTS 750”, respectively.

## RS-232 Connection

The RS-232 port of the CTS 750 is a DB-9 male connector. Table 1-2 lists the pin assignments of the connector.

Table 1-2: RS-232 pin assignments

Pin number	Description
1	Data Carrier Detect
2	Receive Data
3	Transmit Data
4	Data Terminal Ready
5	Signal Ground
6	Data Set Ready
7	Request to Send

**Table 1–2: RS-232 pin assignments (Cont.)**

Pin number	Description
8	Clear to Send
9	Ring Indicator

The instrument is configured as a DTE (Data Terminal Equipment).

To connect the instrument to a computer via RS-232:

1. Locate the RS-232 port on the rear-panel (see Figure 1–1).
2. Connect one end of the RS-232 cable to the instrument and the other end to the computer.
3. Connect both the CTS 750 and the computer to the power system.
4. Turn on the instrument.
5. Turn on the computer.

---

**NOTE.** *If you use the RS-232 port for the computer, you cannot use it for the printer.*

---

## RS-232 Parameter Setup

Table 1–3 shows the default RS-232 parameter values.

**Table 1–3: Default RS-232 parameter values**

Parameter	Default value
Baud Rate	9600
Stop Bits	1
Parity	None
Hardware Handshake	Off
Software Handshake	None
Data Carrier Detect	Off
Tx Delay (seconds)	0
Tx Terminator	LF

To change the RS-232 parameters to other values, perform the steps indicated in Table 1-4.

**Table 1-4: Setting RS-232 parameters**

Press menu button	Select menu page	Highlight parameter	Select choice
UTILITY	REMOTE CONTROL	Baud Rate	1200, 2400, 4800, or 9600
		Stop Bits	1 or 2
		Parity	None, Odd, or Even
		Hardware Handshake	Off or On
		Software Handshake	None or Xon/Xoff
		Tx Delay (seconds)	0, 1, 5, Inc, or Dec
		Tx Terminator	LF, CR, CR/LF, or LF/CR

## RS-232 Connection Test

To verify that the RS-232 connection works, run a terminal emulation program on the computer. Configure the terminal settings to be the same values as those you have selected on the CTS 750. Turn on the instrument, and a one-line identification message should appear on the computer screen.

If the message does not appear or is unreadable, it is an indication that connection is not set up properly. Table 1-5 shows some common problems and their possible solutions.

**Table 1-5: RS-232 connection problems**

Symptom	Probable cause	Solution
No communication	Defective cable	Replace the cable
Garbled characters	Incompatible baud setting	Set the RS-232 parameters on the computer to be the same as those on the instrument
Missing characters	Incorrect flow control	Use a null modem or set the software handshaking to Xon/Xoff



# Programming Model

This section explains the two functional blocks of the CTS 750 SDH Test Set, the subsystems of each functional block, and the two modes in which the instrument operates.

## Functional Blocks

The CTS 750 is made up of two independent functional blocks: a transmitter and a receiver. The transmitter generates an SDH signal of known characteristics for testing. The receiver accepts a telecommunications signal, breaks it apart to see what has gone wrong or been modified, and displays measurements for that signal.

### Transmitter

The transmitter consists of two major subsystems: OUTPUT1 and SOURCE. The OUTPUT1 subsystem commands determine *how* the signal is transmitted and sets characteristics such as the signal type and transmission rate. The SOURCE subsystem commands determine *what* signal is transmitted. Use the SOURCE subsystem commands to set errors, alarms, failures, pointers, overhead, and the payload. These two subsystems correspond to the functions in the **TRANSMIT** menu of your instrument.

### Receiver

The Receiver is made up of two major subsystems: INPUT1 and SENSE. The INPUT1 subsystem commands determine *how* a signal is received and sets characteristics such as the signal type and rate. The SENSE subsystem commands determine *what* signal is received. Use the SENSE subsystem commands to set up tests, capture overhead, and access measurements. These two subsystems correspond to the functions in the **RECEIVE** and **RESULTS** menus of your instrument.

## Modes of Operation

The CTS 750 operates in normal or through mode. Figure 1–3 illustrates how the modes of operation work within the two functional blocks.

### Normal Mode

Use normal mode to generate a signal of known characteristics and to measure a received signal. You can generate a normal or modified signal in this mode. The **SOURce:DATA:TELEcom:SOURce OUTPUT1** command instructs the CTS 750 to operate in normal mode.

**Through Mode**

Use through mode to transmit a received signal without modifying it. The rate and content of the transmitted signal are matched to that of the received signal. The `SOURce:DATA:TELEcom:SOURce INPUT1` command instructs the CTS 750 to operate in through mode; the instrument continues to measure the received signal.

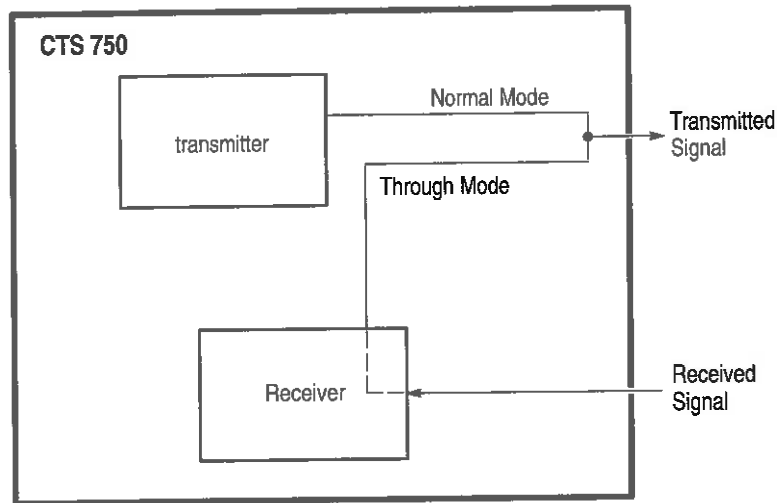

Figure 1-3: Modes of operation

**Information Storage in the Instrument**

Instrument setups, pass/fail tests, and test results are stored in several types of internal buffers and on floppy disk. The number and type of buffers available depend on the type of information stored. The following sections detail the storage locations available for setups, tests, and results.

**Storage of Instrument Setups**

Instrument setups contain all information necessary to set the instrument operation. These setups are stored in internal buffers and on floppy disk as shown in Figure 1-4. The lines and arrows in the illustration show the direction that information is moved. The commands you use to move the setups from one location to another are shown near the lines.

The current buffer (buffer number 0) contains the current instrument setups. Buffers 1 through 5 contain additional instrument setups. The floppy disk can contain any instrument setups.



You can move information between the current buffer and buffers 1 through 5 by using the \*SAV and \*RCL commands. Specify the buffer number with these commands. For example, use the \*SAV 3 command to save the current buffer information in buffer 3 and the \*RCL 3 command to move information from buffer 3 to the current buffer.

You can also move instrument setups between the floppy disk and the buffers. Use the MMEMory:STORe:SETTings command to move information from the buffers to the floppy disk. Specify the file name and buffer number with this command (the current buffer is buffer number 0). For example, use the MMEMory:STORe:SETTings "SET001",2 command to store the information in buffer number 2 to a file named SET001. Use the MMEMory:STORe:SETTings "SET001",0 command to store information in the current buffer to a disk file.

Use the MMEMory:LOAD:SETTings command to move information from the disk to the buffers. For example, use the MMEMory:LOAD:SETTings "SET001",4 command to move information from a file named SET001 on disk to buffer 4. Use the MMEMory:LOAD:SETTings "SET001",0 command to move information from a disk file to the current buffer.

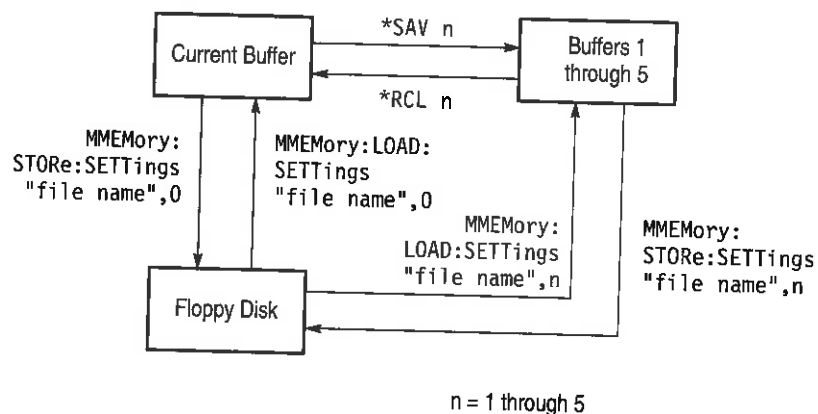

Figure 1-4: How instrument setups are stored

### Storage of Pass/Fail Tests

Pass/fail tests allow you to apply predefined criteria to test results and determine if the tests passed or failed. The pass/fail tests are stored in a current buffer and on floppy disk as shown in Figure 1-5. The lines and arrows in the illustration show the direction that information is moved. The commands you use to move the pass/fail tests from one location to another are shown near the lines. The current buffer contains the current pass/fail test. The floppy disk can contain any pass/fail tests.

Use the `MMEMory:STORe:TEST` command to move information from the current buffer to the disk. Specify the file name with this command. For example, the `MMEMory:STORe:TEST "TEST001"` command will store the current pass/fail test in a file named TEST001 on the disk.

Use the `MMEMory:LOAD:TEST` command to move information from the disk to the current buffer. Specify the file name with this command. For example, the `MMEMory:LOAD:TEST "TEST002"` will copy the pass/fail test in a file named TEST002 on disk to the current buffer.

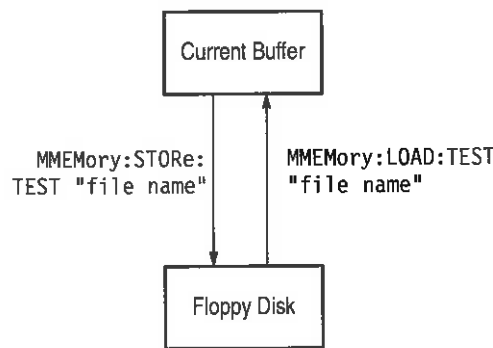

Figure 1-5: How pass/fail tests are stored

### Storage of Test Results

Test results contain measurement obtained from the Receiver and are initiated by the `SENSE:DATA:TELEcom:TEST:STARt`, `SENSE:DATA:TELEcom:TEST:STOP`, and `SENSE:DATA:TELEcom:TEST:DURation` commands. Test results are stored in a different way than the instrument setups and pass/fail tests. The test results are stored in a current and previous buffer, on floppy disk, and in two additional buffers: buffer number -1 and the view buffer (see Figure 1-6).

Buffer number -1 contains only test results that have been copied from disk. The view buffer is a view-only buffer that contains test results from any buffer or from disk. Note that information can be copied only to the view buffer and not from it. The lines in the illustration show the direction that information is moved. The commands you use to move the test results from one location to another are shown near these lines.

The view buffer and disk can contain current or previous test results. Buffer 1 contains current test results, buffer 2 contains previous test results, and buffer number -1 contains test results from disk.

You can move information to the view buffer in three ways. The MMEMory:LOAD:RESUlts moves test results from the disk to this buffer (test results are automatically moved to buffer number -1 when you send this command). The SENSE:DATA:TELEcom:MEASure:BUFFer 2 command moves test results from buffer 2 (previous test results) to the view buffer. And the SENSE:DATA:TELEcom:MEASure:BUFFer 1 command moves test results from buffer 1 (current test results) to the view buffer. When the SENSE:DATA:TELEcom:TEST:STARt command is sent, the test results in buffer 1 are automatically moved to the view buffer.

You can move information from buffers 1 and 2 to disk by using the MMEMory:STORE:RESUlts command. Specify the file name and buffer number 1 or 2 with this command. For example, the MMEMory:STORE:RESUlts "RES001", 2 command stores the test results from buffer 2 to a file named RES001 on the disk.

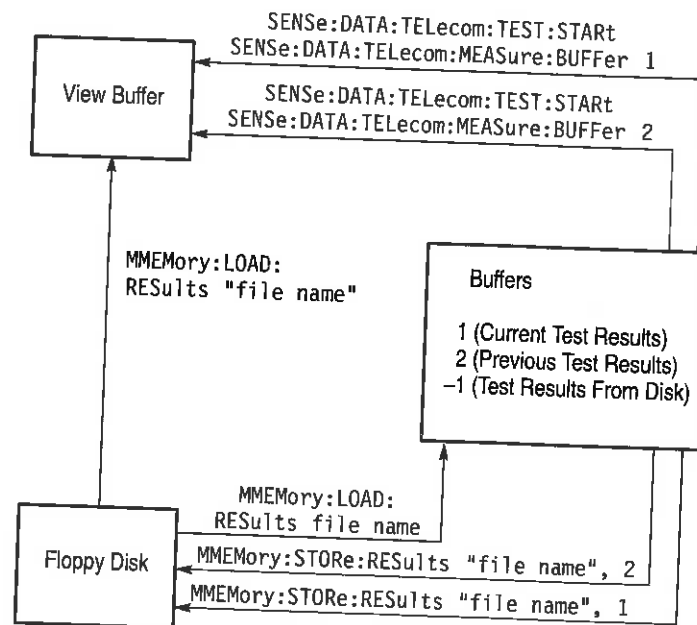

Figure 1-6: How test results are stored



# Examples of Command Usage

This section shows you how to use the commands and queries together to do such things as setting up normal or modified signals, generating errors, and accessing measurements. Use this section to learn about the command language before you start writing programs. Be sure to refer to the *Syntax and Commands* section for more details on how to construct commands and queries correctly.

---

**NOTE.** *The commands and queries in this section are shown as a combination of uppercase and lowercase letters. The uppercase letters signify the accepted abbreviation of the command or query.*

---

## Generating Signals

This section shows you how to generate normal and modified signals.

### Generating Signals in Normal Mode

The following example shows you how to set up a normal electrical signal at an STM-1 rate, using channel one, and which contains a PRBS 2E23-1 test pattern:

1. Reset the CTS 750 to a known state by sending the \*RST command. *Appendix D* lists the default parameter values.
2. Set up the signal physical characteristics by sending the following commands:  
OUTPUT1:TELEcom:RATE STM1  
OUTPUT1:TELEcom:TYPE ELECTrical
3. Set the instrument to normal mode by sending the SOURce:DATA:TELEcom:SOURce OUTPUT1 command.
4. Set up to test on channel one by sending the SOURce:DATA:TELEcom:CHANnel 1 command.
5. Select mapping by sending the SOURce:DATA:TELEcom:PAYLoad:MAPPING EQUIpped command; this command sets the C2 byte to 01.
6. Select a payload test pattern of PRBS 2E23-1 by sending the SOURce:DATA:TELEcom:PAYLoad:PATTERn PRBS23 command.

At this point the instrument is generating a normal signal. You can now modify the signal or insert errors or alarms; the *Generating Modified Signals* section shows you how.

### Generating Signals in Through Mode

When the instrument is operating in through mode, the received signal is transmitted without modification.

Set the instrument to through mode by sending the `SOURce:DATA:TELEcom:SOURce INPUT1` command.

### Generating Modified Signals

This section shows you a few of the many ways to create modified signals.

**Changing the Overhead.** Use the following methods to insert information into the overhead to create a modified signal:

- Insert overhead data into the Section DCC (bytes D1 and D2) from an external protocol analyzer by sending the `SOURce:DATA:TELEcom:OVERhead:INSert SDCC` command. You can also insert data into the line DCC (bytes D4 through D12) or the F1 byte by using `LDCC` or `F1` as the parameter value.
- Change the A1 byte on channel one by sending the `SOURce:DATA:TELEcom:OVERhead:DATA 1,A1,0,246` command. This command sets the A1 byte to a value of 246 (binary 11110110). The table included with the command description on page 2–33 lists the bytes available for selection.
- You can change the APS bytes in two ways:
  - Send the `SOURce:DATA:TELEcom:OVERhead:DATA 1,K1,0,#H0` command to set the K1 byte to zero. Use this command in the same way to set the K2 byte.
  - Send the `SOURce:DATA:TELEcom:OVERhead:APS` command to set the K1 and K2 bytes together. For example, sending the `SOURce:DATA:TELEcom:OVERhead:APS #HFFFF` command sets both K1 and K2 to decimal 255 (all ones in binary).

**Changing Pointers.** Use one of the following methods to adjust pointers.

To create a manual pointer adjustment, follow these steps:

1. Send the `SOURce:DATA:TELEcom:POINter:MODE MANual` command.
2. Send the `SOURce:DATA:TELEcom:POINter:VALue 590` command to create a pointer with a value 590. (If you use a value greater than 782, an illegal pointer is created.)
3. To generate a new data flag every time a pointer changes, send the `SOURce:DATA:TELEcom:POINter:NDFLag ON` command.

To create pointer adjustments that alternately increment and decrement, follow these steps:

1. Send the `SOURce:DATA:TELEcom:POINter:MODE SINGLE` command.
2. Send the `SOURce:DATA:TELEcom:POINter:ACTIon` command to initiate the pointer adjustment.

To create a burst of pointer adjustments, follow these steps:

1. Send the `SOURce:DATA:TELEcom:POINter:MODE BURSt` command.
2. To create three pointer adjustments with each burst of pointers, send the `SOURce:DATA:TELEcom:POINter:NBURst 3` command (if you do not specify the number of pointer adjustments, the instrument assumes you want two pointer adjustments for each burst).
3. Send the `SOURce:DATA:TELEcom:POINter:ACTIon` command to initiate a burst of pointer adjustments.

To create continuous pointer adjustments that alternate between up and down, follow these steps:

1. Send the `SOURce:DATA:TELEcom:POINter:DIRection ALTernate` command (you can also specify `UP` or `DOWN` as the parameter value).
2. Send the `SOURce:DATA:TELEcom:POINter:MODE CONTInuous` command to initiate the continuous pointer adjustments.

**Generating a Failure.** Generate a loss of frame failure by sending the `SOURce:DATA:TELEcom:FAILure:TYPE LOFrame` command. You can also specify `LOSignal` or `LOPointer` as the parameter value to generate a loss of signal or loss of pointer.

**Generating an Alarm.** Generate a path alarm indication by sending the `SOURce:DATA:TELEcom:ALARm PAIS` command. You can also specify a variety of other alarms.

---

**NOTE.** You must send the `SOURce:DATA:TELEcom:FAILure:TYPE NONE` command before you generate any alarm. Failures and alarms cannot be generated simultaneously.

---

**Inserting Errors.** Follow these steps to insert errors:

1. Enable error insertion by sending the `SOURce:DATA:TELEcom:ERRor:ENABle ON` command.
2. Insert a B1 section code violation by sending the `SOURce:DATA:TELEcom:ERRor:TYPE SCV` command. You can also specify LCV, PCV, PFEBE, or DATA as the parameter value to insert a B2 line code violation, B3 active path code violation, path far end block error, or payload data bit error, respectively.
3. You can insert errors at a continuous rate or immediately, upon command:
  - Insert continuous errors at a rate of  $1E-5$  by sending the `SOURce:DATA:TELEcom:ERRor:RATE 1E-5` command. You can select a variety of error rates depending on the signal rate and error type.
  - Force an immediate error insertion by sending the `SOURce:DATA:TELEcom:ERRor:IMMediate` command.

**Creating a Line Frequency Offset.** Follow these steps to create a line frequency offset:

1. Select frequency offset pointer adjustments by sending the `SOURce:DATA:TELEcom:POINter:MODE FOFFset` command.
2. Set the clock source to the internal clock by sending the `SOURce:CLOCK:SOURce INTernal` command.
3. Select line offset with no pointer adjustments by sending the `SOURce:CLOCK:OFFSet:MODE LOFFset` command.
4. Set the line offset value to  $-55.1$  ppm by sending the `SOURce:CLOCK:OFFSet:LVALue -55.1` command. The payload clock offset value will automatically be set to  $-55.1$ .



## Receiving Signals

This section shows you how to set up the CTS 750 to receive a signal, how to check the status of the signal, and how to drop and view overhead data.

### Receiving a Signal Using a Manual Setup

The following example shows you how to manually set up your instrument to receive a normal electrical signal at an STM-1 rate on channel one:

1. Reset the instrument to a known state by sending the \*RST command. *Appendix D* lists the default parameter values.
2. Set up the signal physical characteristics by sending the following commands:  

```
INPUT1:TELEcom:RATE STM1
INPUT1:TELEcom:TYPE ELECtrical
```
3. Set the source of the signal by sending the SENSE:DATA:TELEcom:SOURCE INPUT1 command.
4. Receive the signal through channel one by sending the SENSE:DATA:TELEcom:CHANnel 1 command.

### Receiving a Signal Using Autoscan

If you do not know what kind of signal you are going to receive, send the SENSE:DATA:TELEcom:AUTOscan command. The instrument scans the incoming signal and sets up the receiver to the proper signal rate and payload mapping. The OPC bit is set when autoscan completes execution. To check if the autoscan was able to set up the receiver properly, first send the \*ESR? query, and then send the SYSTem:ERRor? query. You will see an error number and description. If the autoscan failed, check to see if a signal is connected.

### Checking the Physical Status of a Signal

The following steps show you how to check the physical status of a signal:

1. To check if you are receiving the signal, send the INPUT1:TELEcom:STATus? query. If you get a response of LOSIGNAL, try another setup to receive the signal (refer to the *Receiving a Signal Using a Manual Setup* or *Receiving a Signal Using Autoscan* descriptions in this section). If you get a response of MONITOR, you are receiving a monitor signal of low amplitude.
2. Check the optical signal level of the incoming signal by sending the INPUT1:TELEcom:OPWR? query. Values for a valid signal are -32 dBm to -5 dBm.
3. If you still are unable to find the proper settings for the incoming signal, check to see if the level is set properly by sending the INPUT1:TELEcom:LEVEl? query.

**Checking Signal Status** To check the status of the received signal, send the SENSE:DATA:TELEcom:STATUS? query. A response of 8192 indicates a pattern lock on the received signal with no alarms or failures detected. Refer to the description for this query on page 2–113 for list of possible responses. Figure 2–6 on page 2–11 describes how to interpret this type of response.

**Dropping the Overhead** Use one of the following ways to drop the overhead to an external protocol analyzer:

- Drop the Section DCC overhead (bytes D1 and D2) to an external protocol analyzer by sending the SENSE:DATA:TELEcom:OVERhead:DROP SDCC command. You can also drop Line DCC (bytes D4 through D12) or the F1 byte by using LDCC or F1 as the parameter value.
- Drop the F2 byte to an external protocol analyzer by sending the SENSE:DATA:TELEcom:POVerhead:DROP F2 command.

**Viewing the Overhead** Follow these steps to freeze the overhead and to query specific overhead bytes:

1. Start acquiring the overhead by sending the INITiate command.
2. To cause a trigger and stop acquiring overhead, send the TRIGger:IMMediate command.
3. Determine the value of the A1 overhead byte on channel one by sending the SENSE:DATA:TELEcom:OVERhead DATA? 1,A1,0 query. The table included with the query description on page 2–163 lists the bytes available for selection.
4. To start acquiring overhead again, send the INITiate command.

## SDH Signal Testing

This section shows you how to set up several types of tests, how to run these tests, and then how to view the results. The *Storage of Test Results* section starting on page 1–10 describes how test results are stored in the instrument.

### Taking BER Measurements

This example shows you how to run a five-minute BER test and view the test results:

1. Connect a cable from the TRANSMIT output to the RECEIVE input.
2. Reset the instrument to a known state by sending the \*RST command. *Appendix D* lists the default parameter values.
3. Set the test duration to five minutes by sending the SENSE:DATA:TELEcom:TEST:DURATION 0,0,5,0 command.

4. Start the test by sending the `SENSe:DATA:TELEcom:TEST:START` command.
5. Check whether the test is done by sending the `SENSe:DATA:TELEcom:TEST:STATUs?` query. If the first number in the response is 0, the test is done. If the first number is 1, look at the other numbers in the response string to see how long the test has been running. For example, a response of 1,0,0,4,50 indicates that the test has been running for 4 minutes and 50 seconds and is still running. If you had previously set a test duration of 5 minutes, you know that the test will be done in 10 seconds.
6. After the test has completed, send the following queries to view the error measurements:
  - The `SENSe:DATA:TELEcom:TEST:MEASure:ERRor:ECOUnT:SCV?` query returns the number of B1 errors.
  - The `SENSe:DATA:TELEcom:TEST:MEASure:ERRor:ECOUnT:LCV?` query returns the number of B2 errors.
  - The `SENSe:DATA:TELEcom:TEST:MEASure:ERRor:ECOUnT:PCV?` query returns the number of B3 errors.

### Measuring Continuous Pointer Adjustments

The following example shows you how to run a test that initiates continuous pointer adjustments, and then view the measurements:

1. Connect a cable from the TRANSMIT output to the RECEIVE input.
2. Reset the instrument to a known state by sending the `*RST` command. *Appendix D* lists the default parameter values.
3. Set the test duration by sending the `SENSe:DATA:TELEcom:TEST:DURation 0,0,0,0` command. This test will run continuously.
4. Set up continuous pointer adjustments that alternate between up and down by sending the `SENSe:DATA:TELEcom:POINter:MODE CONTInuous` and `SENSe:DATA:TELEcom:POINter:DIRection ALTErnate` commands.
5. Set the pointer adjustment rate to 10 ms by sending the `SENSe:DATA:TELEcom:POINter:RATE 10` command.
6. Start the test by sending the `SENSe:DATA:TELEcom:TEST:START` command.
7. Keep in mind that while the test is running, pointer measurements do not represent the final pointer adjustment measurements. Send the `SENSe:DATA:TELEcom:TEST:STOP` command to stop the test, and then the `SENSe:DATA:TELEcom:MEASure:POINter:` queries to access the final pointer adjustment measurements. To access the pointer adjustment measurements, send the following commands:

- The `SENSe:DATA:TELEcom:MEASure:POINter:PPTR?` query returns the number of positive (up) pointer adjustments.
- The `SENSe:DATA:TELEcom:MEASure:POINter:NPTR?` query returns the number of negative (down) pointer adjustments.
- The `SENSe:DATA:TELEcom:MEASure:POINter:ICOUNT?` query returns the total number of invalid pointers.

## Tributary Signal Testing (Add/Drop Test Option Only)

This section discusses five ways to use the Add/Drop/Test Option of your CTS 750 to test the viability of a network element (NE) and portions of the network.

### CTS 750 as a Stand-Alone Tributary Test Set

You can use the CTS 750 as a stand-alone tributary test set without using any SDH features. You can verify PDH path connection, test path quality, and verify responses to faults. The CTS 750 can both generate and receive PDH signals.

The following example generates a 2 Mb/s tributary signal and then inserts an alarm:

1. Configure your CTS 750 as shown in Figure 1–7.

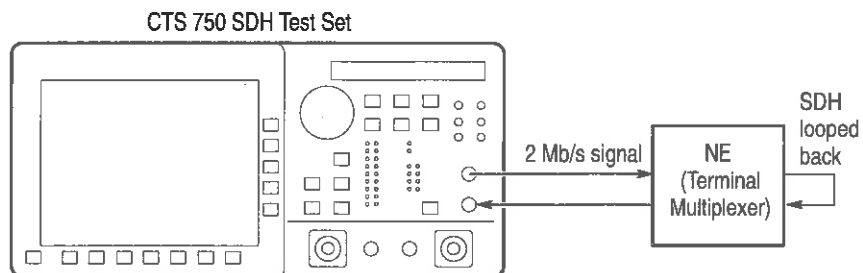

**Figure 1–7: Setup for the CTS 750 as a stand-alone tributary test set**

2. Send the following commands to set up to generate a 2 Mb/s tributary signal with a defined framing and pattern:
 

```
SOURce:DATA:TELEcom:SOURce OUTPUT2
SOURce:DATA:TELEcom:TRIButary:FRAMing UNFRamed
SOURce:DATA:TELEcom:TRIButary:PATtern UWORd
SOURce:DATA:TELEcom:TRIButary:PATtern:UWORd #HAA55
SOURce:DATA:TELEcom:TRIButary:PATtern:UWORd:LENGth 2
```

3. Send the following commands to set up to receive the tributary signal:  
SENSE:DATA:TELEcom:SOURce INPUT2  
SENSE:DATA:TELEcom:TRIButary:FRAMing UNFRamed  
SENSE:DATA:TELEcom:TRIButary:PATtern UWORD  
SENSE:DATA:TELEcom:TRIButary:PATtern:UWORD #HAA55  
SENSE:DATA:TELEcom:TRIButary:PATtern:UWORD:LENgth 2
4. Verify that the CTS 750 is receiving the tributary signal correctly by sending the SENSE:DATA:TELEcom:TRIButary:STATus? query. You should receive a response of 8192 indicating a pattern lock on the tributary signal.
5. Now verify the response to faults by inserting an alarm as follows:
  - a. Send the SENSE:DATA:TELEcom:TRIButary:ALARm AIS command to insert an AIS alarm.
  - b. Then send the SENSE:DATA:TELEcom:TRIButary:STATus? query. You should receive a response of 64 indicating a 2 Mb/s AIS alarm.

### Testing the SDH Tributary Payload Mapping

You can use the CTS 750 to create and monitor SDH tributary payloads. This test can verify error events and alarms in the demapped tributary signal, and can measure multiple layer signal quality.

The CTS 750 maps a pattern into the tributary payload of a SDH signal. This signal is then generated by the CTS 750 and transmitted to an NE. The CTS 750 receives the SDH signal and measures both the SDH and mapped tributary signals.

The following example generates an SDH signal with a 2 Mb/s tributary mapped into it. Then, after the signal has been transmitted through an NE, the CTS 750 receives the signal and measures the demapped 2 Mb/s tributary signal.

1. Configure your CTS 750 as shown in Figure 1–8.

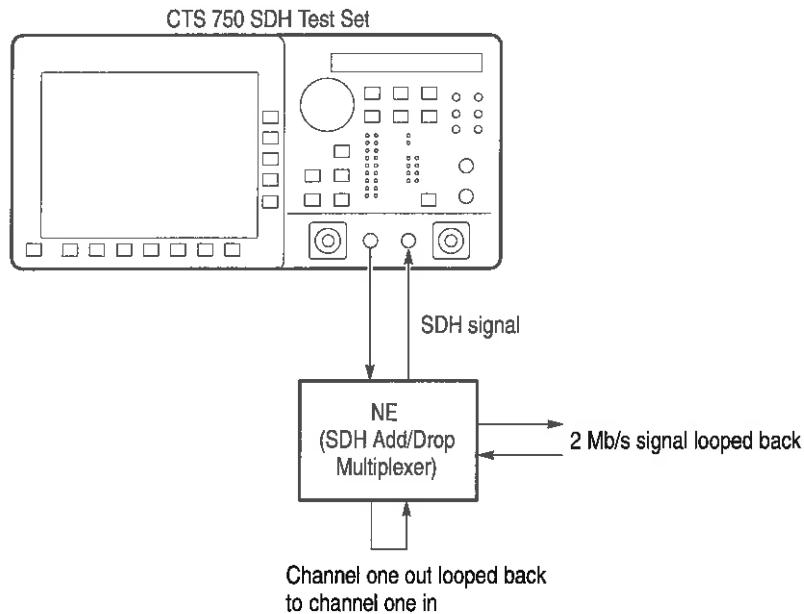

**Figure 1-8: Setup for testing the SDH tributary payload mapping**

2. Send the following commands to set up to generate an SDH signal with a defined tributary payload in channel 1:
 

```
SOURce:DATA:TELEcom:SOURce OUTPUT1
OUTPUT1:TELEcom:RATE STM1
SOURce:DATA:TELEcom:PAYLoad:MAPPing TRIButary
SOURce:DATA:TELEcom:TRIButary:CHANnel 1
SOURce:DATA:TELEcom:TRIButary:MAPPing TUASync
SOURce:DATA:TELEcom:TRIButary:FRAMing PCM31
SOURce:DATA:TELEcom:TRIButary:PATTern PRBS20
SOURce:DATA:TELEcom:TRIButary:BACKground:PATTern PRBS
```
3. Send the following commands to set up to receive and demap the tributary signal:
 

```
SENSe:DATA:TELEcom:SOURce INPUT1
INPUT1:TELEcom:RATE STM1
SENSe:DATA:TELEcom:PAYLoad:MAPPing TRIButary
SENSe:DATA:TELEcom:TRIButary:CHANnel 1
SENSe:DATA:TELEcom:TRIButary:FRAMing PCM31
SENSe:DATA:TELEcom:TRIButary:MAPPing TUASync
SENSe:DATA:TELEcom:TRIButary:PATTern PRBS20
```
4. Verify that the CTS 750 is receiving the tributary signal correctly by sending the `SENSe:DATA:TELEcom:TRIButary:STATus?` query. You should receive a response of 8192 indicating a pattern lock on the demapped tributary signal.

### Testing the Mapping Capability of a Network Element

You can use the CTS 750 to test the mapping capability of an NE. This test can introduce timing variations in the tributary signal and check for error-free mapping, verify mapping for correct channel assignments, and verify responses to errors, alarms, and failures.

The CTS 750 generates a tributary signal which is sent to an NE. The NE maps this tributary signal into the SDH signal. This signal is received by the CTS 750 which then demaps the tributary signal and measures it.

The following example generates a 140 Mb/s tributary signal and then inserts an error:

1. Configure your CTS 750 as shown in Figure 1-9.

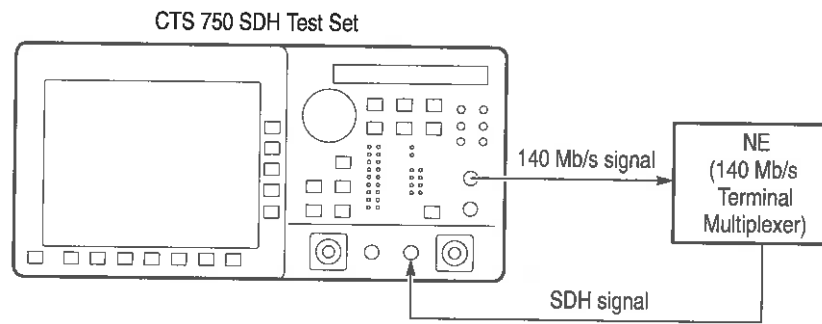

Figure 1-9: Setup for testing the mapping capability of a network element

2. Send the following commands to set up the CTS 750 to generate an unframed 140 Mb/s tributary signal:
 

```
OUTPUT3:TELEcom:RATE M140
SOURCE:DATA:TELEcom:SOURce OUTPUT3
SOURCE:DATA:TELEcom:TRIButary:FRAMing UNFRamed
SOURCE:DATA:TELEcom:TRIButary:PATtern PRBS23
```
3. Send the following commands to set up the CTS 750 to receive the SDH signal with a tributary signal mapped into it:
 

```
SENSe:DATA:TELEcom:SOURce INPUT1
SENSe:DATA:TELEcom:PAYLoad:MAPPing TRIButary
SENSe:DATA:TELEcom:TRIButary:MAPPing M140
SENSe:DATA:TELEcom:TRIButary:FRAMing UNFRamed
SENSe:DATA:TELEcom:TRIButary:PATtern PRBS23
```
4. Send the following commands to verify the NE response to faults; these commands insert a payload bit error into the tributary signal:
 

```
SOURCE:DATA:TELEcom:ERRor:TYPE TRIButary
SOURCE:DATA:TELEcom:TRIButary:ERRor DATA
SOURCE:DATA:TELEcom:ERRor:IMMediate
```

- Verify that the CTS 750 is receiving and demapping the tributary signal correctly by sending the `SENSe:DATA:TELEcom:TRIButary:STATus?` query. You should receive a response of 8704 indicating a 140 Mb/s bit error and pattern lock in the demapped tributary signal.

### Testing the Demapping Capability of a Network Element

You can use the CTS 750 to test the demapping capability of an NE. This test can introduce pointer adjustments, test signal quality, verify correct channel assignments, and verify responses to errors, alarms, and failures.

The CTS 750 generates a tributary signal with a known pattern and maps this signal into the SDH signal. The signal is then sent to an NE, which demaps the tributary signal from the SDH signal. The CTS 750 receiver monitors and measures the demapped tributary signal.

The following example maps a 140 Mb/s tributary signal into an SDH signal, receives the demapped 140 Mb/s signal from the NE, and then initiates pointer adjustments:

- Configure your CTS 750 as shown in Figure 1–10.

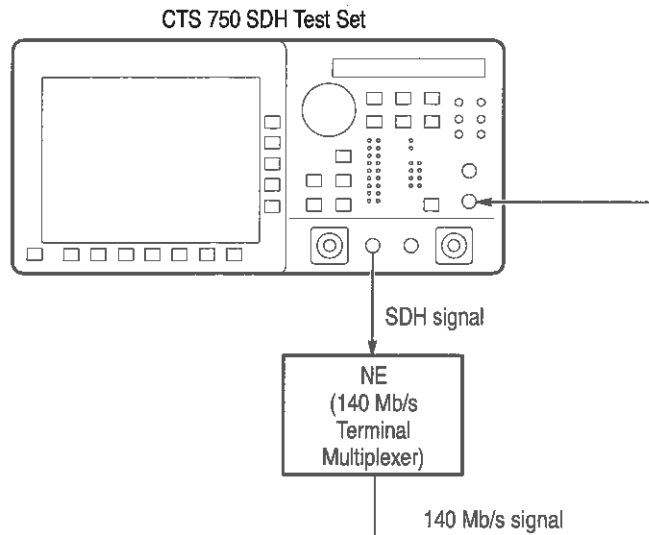

**Figure 1–10: Setup for testing the demapping capability of a network element**

- Send the following commands to set up to map a 140 Mb/s tributary signal into an SDH signal:  
`SOURce:DATA:TELEcom:SOURce OUTPUT1`  
`SOURce:DATA:TELEcom:PAYLoad:MAPPing TRIButary`  
`SOURce:DATA:TELEcom:TRIButary:MAPPing M140`  
`SOURce:DATA:TELEcom:TRIButary:FRAMing FRAMed`  
`SOURce:DATA:TELEcom:TRIButary:PATtern PRBS23`



3. Send the following commands to set up to receive the demapped tributary signal:
 

```
INPUT3:TELEcom:RATE M140
SENSe:DATA:TELEcom:SOURce INPUT3
SENSe:DATA:TELEcom:TRIButary:FRAMing FRAMed
SENSe:DATA:TELEcom:TRIButary:PATtern PRBS23
```
4. Send the following commands to set up continuous pointer adjustments at a 50 ms rate:
 

```
SOURce:DATA:TELEcom:POINter:MODE TRIButary
SOURce:DATA:TELEcom:TRIButary:POINter:MODE CONTinuous
SOURce:DATA:TELEcom:TRIButary:POINter:DIRection ALternate
SOURce:DATA:TELEcom:TRIButary:POINter:RATE 50
```
5. Verify that the CTS 750 is receiving the demapped tributary signal correctly by sending the `SENSe:DATA:TELEcom:TRIButary:STATus?` query. You should receive a response of 8192 indicating a pattern lock and no errors.

### Testing the External Connection of an Add/Drop/Test Set

You can use the CTS 750 to add an external tributary signal into the SDH signal. The testing is controlled by the external tributary test set that generates the tributary signal.

The external tributary test set generates a nonstandard tributary signal. The CTS 750 receives this tributary signal and maps it directly into the SDH signal. The NE receives the SDH signal and demaps the tributary signal. The external tributary test set verifies that the NE demapped the tributary signal correctly.

Follow these steps to map a 2 Mb/s tributary signal into an SDH signal.

1. Configure your CTS 750 as shown in Figure 1–11.

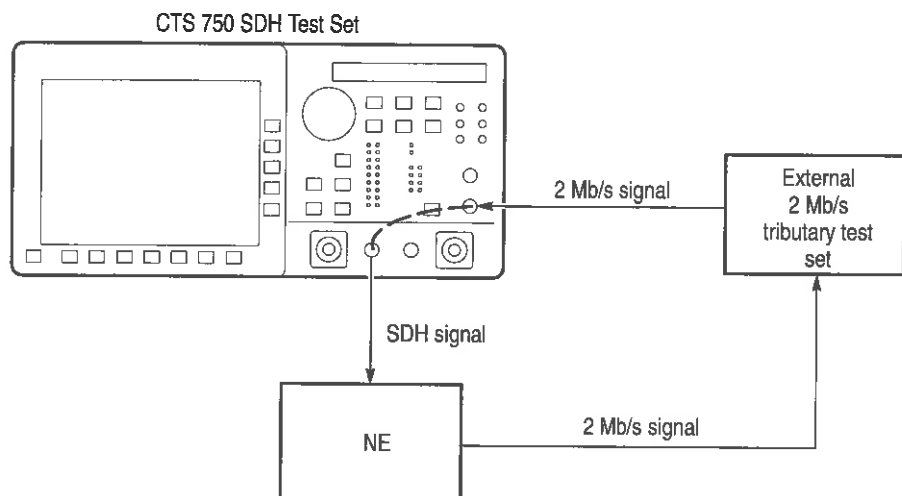

Figure 1–11: Setup for testing the external connection of an Add/Drop/Test set

2. Send the following commands to set up the CTS 750 to map the tributary signal directly into an SDH signal, and then generate the SDH signal (the tributary signal is not measured):  
SOURCE:DATA:TELEcom:SOURce OUTPUT1  
SOURCE:DATA:TELEcom:PAYLoad:MAPPING TRIButary  
SOURCE:DATA:TELEcom:TRIButary:ADD ON  
SOURCE:DATA:TELEcom:TRIButary:MAPPING TUASYNC
3. The external tributary test set should verify that the NE demapped the tributary signal correctly.

# Syntax

This section contains information on the Standard Commands for Programmable Instruments (SCPI) and IEEE 488.2 Common Commands you can use to program your CTS 750.

## SCPI Commands and Queries

SCPI is a standard that provides guidelines for remote programming of instruments. These guidelines provide a consistent programming environment for instrument control and data usage. This environment uses defined programming messages, instrument responses, and data format across all SCPI instruments, regardless of manufacturer. The CTS 750 uses a command language derived from this SCPI standard.

The SCPI language is based on a hierarchical tree structure (see Figure 2–1) that represents a subsystem. The top level of the tree is the root node; it is followed by one or more lower-level nodes.

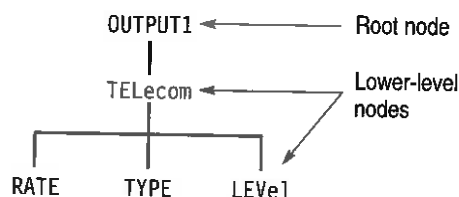

**Figure 2–1: Example of SCPI subsystem hierarchy tree**

You can create commands and queries from these subsystem hierarchy trees. Commands specify actions for the instrument to perform. Queries return information about the state of the instrument.

### Creating Commands

SCPI commands are created by stringing together the nodes of a subsystem hierarchy tree and separating each node by a colon.

In Figure 2–1, OUTPUT1 is the root node and TELEcom, RATE, TYPE, and LEVe1 are the lower-level nodes. To create a SCPI command, start with the root node OUTPUT1 and move down the tree structure adding nodes until you reach the end of a branch.

Most commands and some queries have parameters; you must include a value for these parameters. If you specify a parameter value that is out of range, the parameter will be set to the default. The commands sections starting on page 2–13 list the valid values for all parameters.

OUTPUT1:TELEcom:LEVel HIGH is an example of a valid SCPI command using the hierarchy tree in Figure 2–1.

**Creating Queries**

To create a query, start at the root node of a tree structure, move down to the end of a branch, and then add a question mark. OUTPUT1:TELEcom:LEVel? is an example of a valid SCPI query using the hierarchy tree in Figure 2–1.

**Parameter Types**

Parameter types are given for every parameter in the command and query descriptions. The parameters are enclosed in brackets, for example, <pattern>. The parameter type is listed after the parameter and is enclosed in parentheses, for example, (discrete). Some parameter types are defined specifically for the CTS 750 command set and some are defined by ANSI/IEEE 488.2-1987 (refer to Table 2–1).

**Table 2–1: Parameter types used in syntax descriptions**

Parameter type	Description	Example
binary	Binary numbers	#B0110
binary block <sup>1</sup>	A specified length of binary data	#512234xxxx . . . where 5 indicates that the following 5 digits (12234) specify the length of the data in bits; xxxx ... indicates the binary data
boolean	Boolean numbers or values	ON or 1 OFF or 0
discrete	A list of specific values	HIGH, LOW, MID, PRBS23
hexadecimal <sup>2</sup>	Hexadecimal numbers (0–9, A, B, C, D, E, F)	#HAA, #H1

Table 2–1: Parameter types used in syntax descriptions (Cont.)

Parameter type	Description	Example
NR1-numeric <sup>2,3</sup>	Integers	0, 1, 15, -1
NR2-numeric <sup>2</sup>	Decimal numbers	1.2, 3.141516, -6.5
NR3-numeric <sup>2</sup>	Floating point numbers	3.1415E-9, -16.1E5
string <sup>4</sup>	Alphanumeric characters (must be within quotation marks)	"Testing 1, 2, 3"

<sup>1</sup> Defined in ANSI/IEEE 488.2 as "Definite Length Arbitrary Block Response Data."

<sup>2</sup> An ANSI/IEEE 488.2–1987-defined parameter type.

<sup>3</sup> Some commands and queries will accept a hexadecimal value even though the parameter type is defined as NR1-numeric.

<sup>4</sup> Defined in ANSI/IEEE 488.2 as "String Response Data."

### Abbreviating Commands, Queries, and Parameters

You can abbreviate most SCPI commands, queries, and parameters to an accepted short form. This manual shows these short forms as a combination of upper and lower case letters. The upper case letters tell you what the accepted short form should consist of. As shown in Figure 2–2, you can create a short form by using only the upper case letters. The accepted short form and long form are equivalent and request the same action of the instrument.

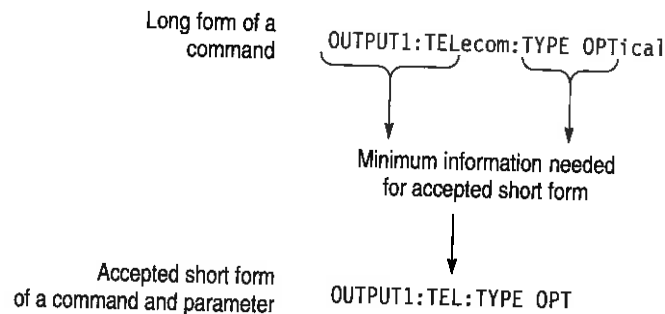

Figure 2–2: Example of abbreviating a command

**NOTE.** The numeric part of a command or query must always be included in the accepted short form. In Figure 2–2, the "1" of "OUTPUT1" is always included in the command or query.

### Controlling Responses to Queries

You can control the form of responses returned by queries by changing the parameter values of `SYSTEM:HEADers` and `SYSTEM:VERBose`. These two commands control whether the query nodes are returned with the response, and, if the query nodes are returned, whether they are in the long or short form. `SYSTEM:HEADers` controls the presence of the query nodes, and `SYSTEM:VERBose` controls the length of these nodes. Table 2-2 shows the possible combinations of these commands and an example of a query response.

**Table 2-2: Using commands to control the response to a query**

SYSTEM:HEADers set to:	SYSTEM:VERBose set to:	Example of a response
1 or ON	1 or ON	OUTPUT1:TELECOM:TYPE OPTICAL
1 or ON	0 or OFF	OUTPUT1:TEL:TYPE OPT
0 or OFF	0 or OFF	OPT
0 or OFF	1 or ON	OPTICAL

### Chaining Commands and Queries

You can chain several commands or queries together into a single message. To create a chained message, first create a command or query, add a semicolon (;), and then add more commands or queries and semicolons until you are done. Figure 2-3 illustrates a chained message consisting of several commands and queries. The single chained message should end in a command or query, not a semicolon. Responses to any queries in your message are separated by semicolons.

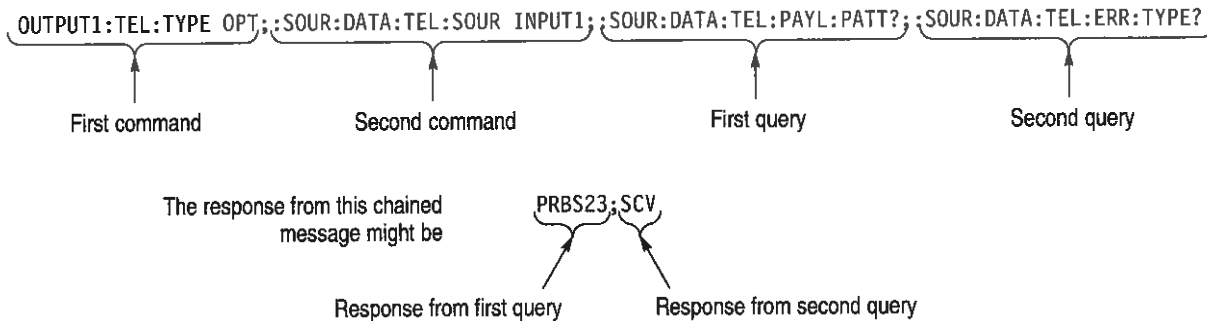

**Figure 2-3: Example of chaining commands and queries**

If a command or query has the same root and lower-level nodes as the previous command or query, you can omit these nodes. In Figure 2-4, the second command has the same root and lower-level nodes (`SOURCE:DATA:TELECOM`) as the first command, so these nodes can be omitted.

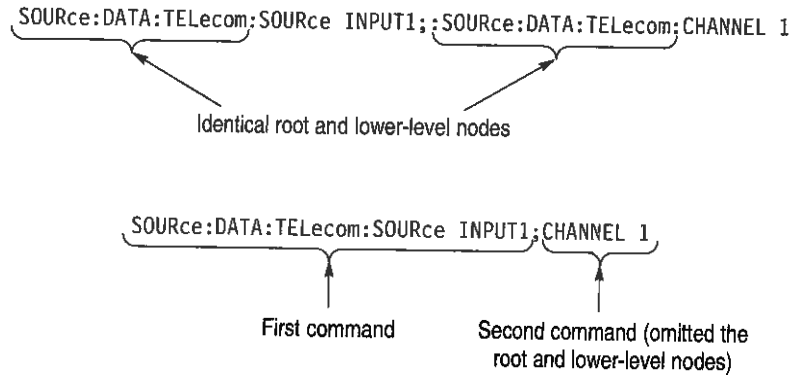

**Figure 2-4: Example of omitting root and lower-level nodes in chained message**

### General Rules

Here are some general rules for using SCPI commands, queries, and parameters:

- You can use single ( ' ') or double ( " ") quotation marks for quoted strings, but you cannot use both types of quotation marks for the same string.

correct: "This string uses quotation marks correctly."

correct: 'This string also uses quotation marks correctly.'

incorrect: "This string does not use quotation marks correctly.'

- You can use upper case, lower case, or a mixture of both cases for all commands, queries, and parameters.

`INPUT1:TELECOM:TYPE ELECTRICAL`

is the same as

`input1:telecom:type electrical`

and

`INPUT1:telecom:Type ELECTRICAL`

- No embedded spaces are allowed between or within nodes.

correct: `OUTPUT1:TELecom:TYPE OPTical`

incorrect: `OUTPUT1: TELecom: TYPE OPTical`

incorrect: `OU TPUT1:TELe com:TYPE OPTical`

## IEEE 488.2 Common Commands

**Description** ANSI/IEEE Standard 488.2 defines the codes, formats, protocols, and usage of common commands and queries used on the GPIB interface between the controller and the instruments. The CTS 750 complies with this standard.

**Command and Query Structure** The syntax for an IEEE 488.2 common command is an asterisk (\*) followed by a command and, optionally, a space and parameter value. The syntax for an IEEE 488.2 common query is an asterisk (\*) followed by a query and a question mark. All of the common commands and queries are listed in the last part of the *Syntax and Commands* section. The following are examples of common commands:

- \*ESE 16
- \*CLS

The following are examples of common queries:

- \*ESR?
- \*IDN?



# Functional Command Groups

All of the commands and queries in *Syntax and Commands* are organized into functional groups. Each section covers one functional group. For example, *Transmit Commands* contains all commands and queries that allow you to set up and transmit a signal. The commands and queries within each functional group are further organized into subsystems. For example, within *Transmit Commands* are subsystems that allow you to set the physical characteristics of a signal (the OUTPUT1 subsystem) and pointer adjustments (the SOURCE:DATA:TELEcom:POINter subsystem).

The functional groups and their subsystems are listed in Table 2-3.

**Table 2-3: Functional groups and their subsystems**

Functional group	Subsystem	Description	Starts on page
Transmit Commands	OUTPUT1	Controls physical setup of transmitted SDH signal	2-14
	OUTPUT2	Sets the characteristics of the transmitted or dropped 2 Mb/s tributary signal (Add/Drop Test Option Only)	2-17
	OUTPUT3	Sets the characteristics of the transmitted or dropped 34 Mb/s or 140 Mb/s tributary signal (Add/Drop Test Option Only)	2-19
	SOURCE:CLOCK	Controls transmitter clock	2-20
	SOURCE:DATA:TELEcom	Controls transmitter setup	2-25
	SOURCE:DATA:TELEcom:OVERhead and POVERhead	Controls transmitter overheads	2-31
	SOURCE:DATA:TELEcom:ERRor, ALARm, and FAILure	Controls transmitter abnormalities	2-41
	SOURCE:DATA:TELEcom:POINter	Controls transmitter pointers	2-47
	SOURCE:DATA:TELEcom:TRIButary	Controls transmitted or dropped tributary signal (Add/Drop Test Option Only)	2-63
	SOURCE:DATA:TELEcom:TRIButary:ERRor, ALARm, and FAILure	Controls abnormal conditions in the transmitted or dropped tributary signal (Add/Drop Test Option Only)	2-73
SOURCE:DATA:TELEcom:TRIButary:POINter	Controls pointers in the transmitted or dropped tributary signal (Add/Drop Test Option Only)	2-76	
SOURCE:DATA:TELEcom:JITter	Controls the jitter/wander generator	2-92	

Table 2–3: Functional groups and their subsystems (Cont.)

Functional group	Subsystem	Description	Starts on page
Receive Commands	INPUT1	Sets up physical connection of received SDH signal	2–100
	INPUT2	Sets the characteristics of the received or added 2 Mb/s tributary signal (Add/Drop Test Option Only)	2–105
	INPUT3	Sets the characteristics of the received or added 34 Mb/s or 140 Mb/s tributary signal (Add/Drop Test Option Only)	2–108
	SENSe:DATA:TELEcom	Sets up receiver	2–111
	SENSe:DATA:TELEcom:TEST	Starts and stops measurements	2–118
	SENSe:DATA:TELEcom:TEST:JITter	Sets/queries jitter compliance tests	2–124
	SENSe:DATA:TELEcom:OVERhead and POverhead	Allows access to receiver overheads	2–163
	SENSe:DATA:TELEcom:MEASure	Allows access to measurements	2–169
	SENSe:DATA:TELEcom:MEASure:STESTs	Controls pass/fail tests	2–187
	SENSe:DATA:TELEcom:MEASure:JITter	Access to jitter measurements	2–195
	SENSe:DATA:TELEcom:MEASure:WANDer	Allows access to wander measurements (Add/Drop Test Option Only)	2–211
	SENSe:DATA:TELEcom:MEASure:TRIButary	Allows access to measurements of tributary signals (Add/Drop Test Option Only)	2–217
	SENSe:DATA:TELEcom:AUTOscan	Automatically sets up receiver	2–228
	SENSe:DATA:TELEcom:TRIButary	Controls viewing of tributary signal (Add/Drop Test Option Only)	2–229
SENSe:DATA:TELEcom:JITter	Jitter input signal setup	2–241	
Transmitter and Receiver Setup Commands	INSTRument	Controls transmitter and receiver settings	2–251
Trigger and Capture Commands	INITiate	Starts overhead capture	2–253
	TRIGger:IMMEDIATE	Stops overhead capture	2–253

**Table 2-3: Functional groups and their subsystems (Cont.)**

Functional group	Subsystem	Description	Starts on page
Input/Output Commands	MMEMory	Controls disk drive	2-257
	MMEMory Jitter	Controls disk drive for jitter data	2-265
	DISPlay	Sets display intensity	2-275
	HCOPy	Controls printer	2-276
	SYSTem:COMMunicate	Controls RS-232 setups	2-280
Instrument Control Commands	SYSTem	Controls general instrument functions	2-289
Diagnostic Commands	DIAGnostic	Controls self tests	2-301
	CALibrate	Controls jitter self tests	2-308
IEEE 488.2 Common Commands	(no subsystems; every command and query begins with *)	Allows access to generic commands	2-311

Each functional group section begins with a description of the functional group and is followed by a list of the subsystems included in the functional group. Then, for each of the subsystems, a description and hierarchy tree are given.

Each command and query within each subsystem are listed in the functional group sections in the format illustrated in Figure 2-5. For the sake of clarity, two tables are always given even though the parameters may be identical.

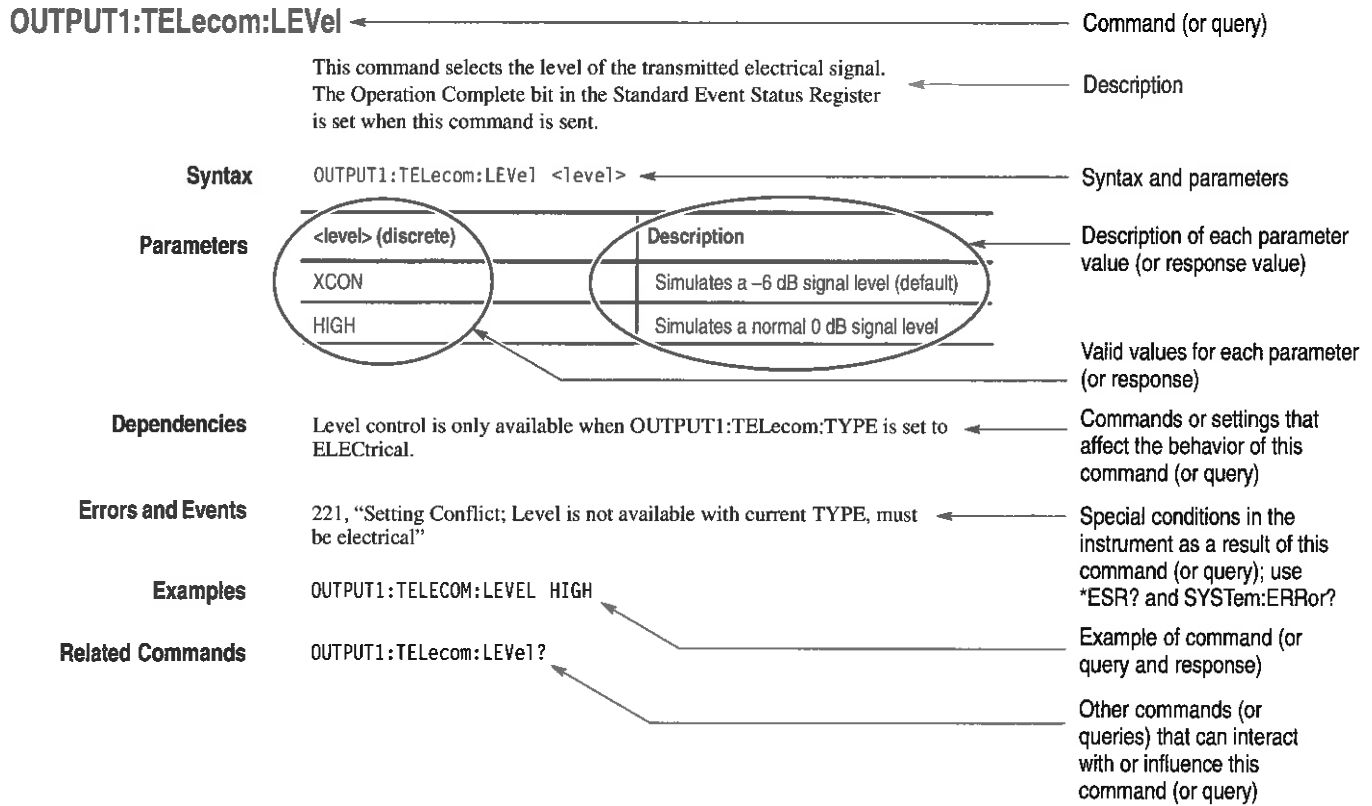

Figure 2-5: Example of command listing

**NOTE.** Some commands and queries follow a different format than shown in Figure 2-5 (for example, the SENSE:DATA:TELEcom:MEASure queries). An explanation of this format is found at the beginning of the section containing the commands and queries.

In the *Syntax and Commands* section you will see a different kind of Parameter or Response table for a few commands or queries. Figure 2-6 shows you an example of a <decimal value> response table. The parameter or response value returned is the sum of the decimal values listed in the left column and depends on which bits are set. Follow the step numbers in the example to interpret a <decimal value> parameter or response.

Table X-X: Response Table

<decimal value> (NR1-numeric)	bit	definition
1	0	LOS
2	1	LOF
4	2	OOF
8	3	LOP
16	4	Line AIS
32	5	Path AIS
64	6	Error
128	7	Undefined
256	8	K1/K2 change
512	9	Line FERF
1024	10	Path FERF
2048	11	Pointer adjust
4096	12	NDF
8192	13	Pattern lock
16384	14	Not used
32768	15	Not used

1 A response of 9216 is received.

2 Find which decimal values add up to the response of 9216 (1024 + 8192 = 9216).

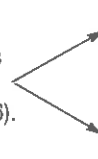

3 Read across the selected decimal values to the bit and definition columns to interpret the response. In this example, bits 10 and 13 are set indicating a path yellow and pattern lock.

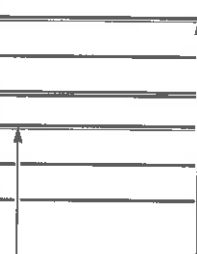

Figure 2-6: How to interpret a <decimal value> parameter or response



# Transmit Commands

The Transmit Commands allow you to set the conditions for the signal to be transmitted, including abnormal conditions. This section contains all of the commands and queries for each of the following Transmit subsystems:

- OUTPUT1
- OUTPUT2 (Add/Drop Test Option Only)
- OUTPUT3 (Add/Drop Test Option Only)
- SOURCE:CLOCK
- SOURCE:DATA:TELECOM
- SOURCE:DATA:TELECOM:OVERHEAD and POverhead
- SOURCE:DATA:TELECOM:ERROR, ALARM, and FAILURE
- SOURCE:DATA:TELECOM:POINTER
- SOURCE:DATA:TELECOM:TRIBUTARY (Add/Drop Test Option Only)
- SOURCE:DATA:TELECOM:TRIBUTARY:ERROR, ALARM, and FAILURE (Add/Drop Test Option Only)
- SOURCE:DATA:TELECOM:TRIBUTARY:POINTER (Add/Drop Test Option Only)
- SOURCE:DATA:TELECOM:TRIBUTARY:POVerhead (Add/Drop Test Option Only)
- SOURCE:DATA:TELECOM:JITTER (SDH/PDH Jitter/Wander Test Option Only)

## OUTPUT1 Subsystem

This section describes the commands and queries that set the rate, type, and level of the signal to be transmitted. Figure 2–7 shows the hierarchy tree for this subsystem.

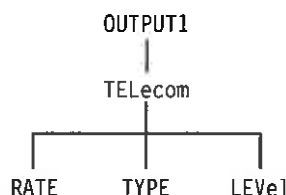

Figure 2–7: OUTPUT1 subsystem

### OUTPUT1:TELEcom:RATE

This command sets or queries the transmitter signal output rate.

**Syntax** OUTPUT1:TELEcom:RATE <rate>  
OUTPUT1:TELEcom:RATE?

Parameters	<rate> (discrete)	Description
	STM0	51.84 MHz
	STM1	155.52 MHz (default)
	STM4	622.08 MHz (requires the optical option)

**Dependencies** None

**Errors and Events** 221, “Settings conflict; Rate is not available with current Line Interface module or operating mode”

221, “Settings conflict; Optical module required”



**Examples** Set: OUTPUT1:TELECOM:RATE STM1  
 Query: OUTPUT1:TELECOM:RATE?  
 Response: STM14

**Related Commands** OUTPUT1:TELEcom:TYPE  
 SOURce:DATA:TELEcom:SOURce

## OUTPUT1:TELEcom:TYPE

This command sets or queries the output transmitter signal type.

**Syntax** OUTPUT1:TELEcom:TYPE <type>  
 OUTPUT1:TELEcom:TYPE?

Parameters	<type> (discrete)	Description
	ELECTrical	Electrical signal output (default)
	OPTical	Optical signal output (requires the optical option)

**Dependencies** None

**Errors and Events** 221, "Settings conflict; Type is not available with current Line Interface module"

**Examples** Set: OUTPUT1:TELECOM:TYPE ELECTRICAL  
 Query: OUTPUT1:TELECOM:TYPE?  
 Response: OPTICAL

**Related Commands** OUTPUT1:TELEcom:RATE

## OUTPUT1:TELEcom:LEVel

This command sets or queries the transmitted electrical signal level.

**Syntax** OUTPUT1:TELEcom:LEVel <level>  
OUTPUT1:TELEcom:LEVel?

Parameters	<level> (discrete)	Description
	XCONnect	Simulates a -6dB signal level (default)
	HIGH	Simulates a normal 0 dB signal level

**Dependencies** This command applies only when OUTPUT1:TELEcom:TYPE is set to ELECTRical.

**Errors and Events** 221, "Settings conflict; Level is not available with current type, must be electrical"

**Examples**  
Set:       OUTPUT1:TELECOM:LEVEL HIGH  
Query:     OUTPUT1:TELECOM:LEVEL?  
Response:  HIGH

**Related Commands** None

## OUTPUT2 Subsystem

Add/Drop Test Option Only

This section describes the commands and queries that set the characteristics of the transmitted or dropped 2 Mb/s tributary signal. Figure 2–8 shows the hierarchy tree for this subsystem.

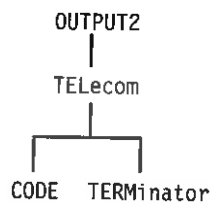

Figure 2–8: OUTPUT2 subsystem

### OUTPUT2:TELEcom:CODE

Add/Drop Test Option Only

This command sets or queries the signal coding of the 2 Mb/s tributary signal.

**Syntax** OUTPUT2:TELEcom:CODE <trib1 output code>  
OUTPUT2:TELEcom:CODE?

Parameters	<trib1 output code> (discrete)	Description
	HDB3	High Density Bipolar 3 (default)

**Dependencies** The instrument must be transmitting or dropping a 2 Mb/s tributary signal for this command to apply.

**Errors and Events** None

**Examples** Set: OUTPUT2:TELECOM:CODE HDB3  
 Query: OUTPUT2:TELECOM:CODE?  
 Response: HDB3

**Related Commands** SOURce:DATA:TELEcom:SOURce  
 SENSe:DATA:TELEcom:TRIButary:DROP

## OUTPUT2:TELEcom:TERMinator

Add/Drop Test Option Only

This command sets or queries the signal terminator for the 2 Mb/s transmit connector.

**Syntax** OUTPUT2:TELEcom:TERMinator <trib1 output termin>  
 OUTPUT2:TELEcom:TERMinator?

Parameters	<trib1 output termin> (discrete)	Description
	BALanced	120 Ω connector (default)
	UNBALanced	75 Ω connector

**Dependencies** The instrument must be transmitting or dropping a 2 Mb/s tributary signal for this command to apply.

**Errors and Events** None

**Examples** Set: OUTPUT2:TELECOM:TERMINATOR BALANCED  
 Query: OUTPUT2:TELECOM:TERMINATOR?  
 Response: BALANCED

**Related Commands** SOURce:DATA:TELEcom:SOURce  
 SENSe:DATA:TELEcom:TRIButary:DROP

## OUTPUT3 Subsystem

Add/Drop Test Option Only

This section describes the commands and queries that set the characteristics of the transmitted or dropped 34 Mb/s or 140 Mb/s tributary signal.



Figure 2–9: OUTPUT3 subsystem

### OUTPUT3:TELEcom:RATE

Add/Drop Test Option Only

This command sets or queries the 34 Mb/s or 140 Mb/s tributary output rate.

**Syntax** OUTPUT3:TELEcom:RATE <trib2 output rate>  
OUTPUT3:TELEcom:RATE?

#### Parameters

<trib2 output rate> (discrete)	Description
M34	34.368 Mb/s (default)
M140	139.264 Mb/s

**Dependencies** None

**Errors and Events** None

**Examples**

Set:       OUTPUT3:TELECOM:RATE M34

Query:     OUTPUT3:TELECOM:RATE?

Response:  M34

**Related Commands** SOURCE:DATA:TELEcom:SOURce

## SOURce:CLOCK Subsystem

This section describes the commands and queries that control the transmitter clock. You must set the SOURce:DATA:TELEcom:POINter:MODE command to FOffset for any of the SOURce:CLOCK subsystem commands to be valid. Figure 2–10 shows the hierarchy tree for this subsystem.

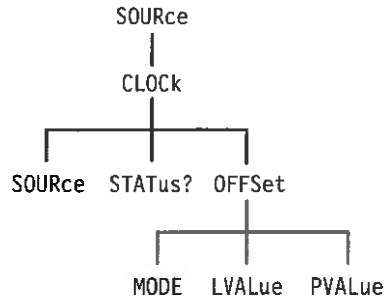

**Figure 2–10: SOURce:CLOCK subsystem**

Table 2–4 shows the interaction between the major commands of this subsystem. Refer to this table to see which combinations of commands and parameters are valid.

**Table 2–4: Interaction Between SOURce:CLOCK Commands**

To control:	Set SOURce:CLOCK: SOURce to:	Set SOURce:CLOCK: OFFSet:MODE to:	Set SOURce:CLOCK: OFFSet:LVALue to:	Set SOURce:CLOCK: OFFSet:PVALue to:
Pointer movements	INternal, E2MB, or RECovered	POINters	Set to 0; no changes allowed	Any value from –100 ppm to +100 ppm in increments of 0.1 ppm
Line offset, no pointers	INternal or RECovered	LOFFset	SDH rates: –100 ppm to +100 ppm 2 Mb/s rate: –50 ppm to +50 ppm 34 Mb/s rate: –130 ppm to +130 ppm 140 Mb/s rate: –100 ppm to +100 ppm All ranges in increments of 0.1 ppm	Automatically set to the same value as LVALue; you can not directly change PVALue

**SOURce:CLOCK:SOURce**

This command sets or queries the transmitter clock source. The OPC bit in the Standard Event Status Register is set when this command has completed execution.

**Syntax** SOURce:CLOCK:SOURce <clock source>  
SOURce:CLOCK:SOURce?

**Parameters**

<clock source> (discrete)	Description
INTernal	Internal clock (default)
E2MB	External 2 Mb
RECovered	Recovered from the received signal
TEXternal	Tributary external clock (Add/Drop Test Option Only)

**Dependencies** RECovered is not allowed if you are set up to receive a tributary signal at the same time you are set up to transmit a SDH signal.

**Errors and Events** None

**Examples**  
Set:       SOURCE:CLOCK:SOURCE INTERNAL  
Query:     SOURCE:CLOCK:SOURCE?  
Response:  INTERNAL

**Related Commands** None

## SOURce:CLOCK:STATus?

This query returns the status of the clock phase locked loop. Use this query to determine if you have a lock on an external clock source or after you change the clock source.

**Syntax** SOURce:CLOCK:STATus?

Response	<clock status> (boolean)	Description
	0	Unlocked
	1	Locked

**Dependencies** None

**Errors and Events** None

**Examples**  
 Query: SOURce:CLOCK:STATus?  
 Response: 1

**Related Commands** SOURce:CLOCK:OFFSet:MODE

## SOURce:CLOCK:OFFSet:MODE

This command sets or queries the clock offset mode and determines how the commands SOURce:CLOCK:OFFSet:MODE:LVALue and SOURce:CLOCK:OFFSet:MODE:PVALue interact. When you send the SOURce:CLOCK:OFFSet:MODE command, the values of LVALue and PVALue are reset to 0 which might create a discontinuity in the output signal for a brief time. Then you can change LVALue and PVALue to valid values (Table 2–4 on page 2–20 describes the interaction between the major SOURce:CLOCK commands).

**Syntax** SOURce:CLOCK:OFFSet:MODE <clock offset mode>  
 SOURce:CLOCK:OFFSet:MODE?



Parameters	<clock offset mode> (discrete)	Description
	LOFFset	Changes to LVALue are tracked in PVALue
	POINter	Changes to PVALue are allowed

**Dependencies** POINters is valid only for SDH rates and when SOURce:CLOCK: SOURce is set to INTernal, E2MB, or RECovered.

LOFFset is valid only when SOURce:CLOCK:SOURce is set to INTernal, E2MB, or RECovered. LOFFset does not apply when transmitting a tributary signal while using a RECovered clock source.

**Errors and Events** None

**Examples** Set: SOURCE:CLOCK:OFFSET:MODE LOFFSET

Query: SOURCE:CLOCK:OFFSET:MODE?

Response: POINTERS

**Related Commands** SOURce:CLOCK:OFFSet:LVALue  
SOURce:CLOCK:OFFSet:PVALue

## SOURce:CLOCK:OFFSet:LVALue

This command sets or queries the line clock offset value in ppm (parts per million).

**Syntax** SOURce:CLOCK:OFFSet:LVALue <line clock offset>  
SOURce:CLOCK:OFFSet:LVALue?

Parameters	<line clock offset> (NR2-numeric)	Description
	SDH rates: -100 ppm to +100 ppm	The line clock offset is set to this value (default = 0)
	2 Mb/s rate: -50 ppm to +50 ppm	
	34 Mb/s rate: -130 ppm to +130 ppm	
	140 Mb/s rate: -100 ppm to +100 ppm	
	All ranges in increments of 0.1 ppm	

- Dependencies** This command applies only when `SOURCE:CLOCK:SOURce` is set to `INTERNAL` or `RECOVERed` and `SOURCE:CLOCK:OFFSet:MODE` is set to `LOFFset`.
- Errors and Events** 221, "Settings conflict; Frequency offset disabled with current transmit clock"
- Examples**  
 Set: `SOURCE:CLOCK:OFFSet:LVALUE 20`  
 Query: `SOURCE:CLOCK:OFFSet:LVALUE?`  
 Response: 10.1
- Related Commands** `SOURCE:CLOCK:OFFSet:MODE`

## SOURCE:CLOCK:OFFSet:PVALue

This command sets or queries the payload clock offset value in ppm (parts per million).

- Syntax** `SOURCE:CLOCK:OFFSet:PVALue <payload clock offset>`  
`SOURCE:CLOCK:OFFSet:PVALue?`
- Parameters**
- | <payload clock offset> (NR2-numeric)  | Description   |
|---|---|
| Any decimal number in the range -100 ppm to +100 ppm in increments of 0.1 ppm | The payload clock offset is set to this value (default = 0) |
- Dependencies** This command is valid only when `SOURCE:CLOCK:OFFSet:MODE` is set to `POINTers` and when transmitting or receiving a SDH signal.
- Errors and Events** None
- Examples**  
 Set: `SOURCE:CLOCK:OFFSet:PVALUE 20`  
 Query: `SOURCE:CLOCK:OFFSet:PVALUE?`  
 Response: 12.4
- Related Commands** `SOURCE:CLOCK:OFFSet:MODE`  
`SOURCE:CLOCK:OFFSet:LVALUE`

## SOURce:DATA:TELEcom Subsystem

This section describes the commands and queries that set up the structure of the signal to be transmitted for both active and inactive channels. Figure 2–11 shows the hierarchy tree for this subsystem.

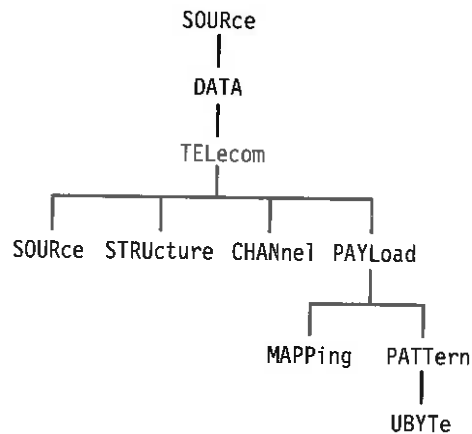

Figure 2–11: SOURce:DATA:TELEcom subsystem

## SOURce:DATA:TELEcom:SOURce

This command sets or queries the output signal source.

**Syntax** SOURce:DATA:TELEcom:SOURce <source>  
SOURce:DATA:TELEcom:SOURce?

Parameters	<source> (discrete)	Description
	OUTPUT1	All SDH rates; normal mode (default)
	OUTPUT2	2 Mb/s tributary signal (Add/Drop Test Option Only)
	OUTPUT3	34 Mb/s or 140 Mb/s tributary signal (Add/Drop Test Option Only)
	INPUT1	Through mode

**Dependencies** None

**Errors and Events** 221, “Settings conflict; Not available without tributary option”

**Examples**    Set:        SOURCE:DATA:TELECOM:SOURCE OUTPUT1  
                   Query:      SOURCE:DATA:TELECOM:SOURCE?  
                   Response: OUTPUT1

**Related Commands**    OUTPUT1:TELEcom:RATE

## SOURce:DATA:TELEcom:STRUcture

This command sets or queries the structure of a signal.

**Syntax**    SOURce:DATA:TELEcom:STRUcture <output structure>  
                   SOURce:DATA:TELEcom:STRUcture?

Parameters	<output structure> (discrete)	Description
	AU3	AU-3 structure (STM0 only)
	AU4	AU-4 structure (default) (STM0 and STM4 only)

**Dependencies**    AU-3 is only available for the STM-0 rate.

**Errors and Events**    None

**Examples**    Set:        SOURCE:DATA:TELECOM:STRUCTURE AU4  
                   Query:      SOURCE:DATA:TELECOM:STRUCTURE?  
                   Response: AU3

**Related Commands**    OUTPUT1:TELEcom:RATE

## SOURce:DATA:TELEcom:CHANnel

This command sets or queries the active channel.

**Syntax** SOURce:DATA:TELEcom:CHANnel <channel>  
SOURce:DATA:TELEcom:CHANnel?

Parameters	<channel> (NR1-numeric)	Description
	1	STM0 or STM-1 rate (default)
	1 to 4	STM-4 rate

**Dependencies** OUTPUT1:TELEcom:RATE must be set to STM4 if you choose a channel value greater than one.

**Errors and Events** 221, "Settings conflict; Only one channel is available"  
500, "Execution warning; Numeric value greater than maximum limit"

**Examples** Set: SOURCE:DATA:TELECOM:CHANNEL 1  
Query: SOURCE:DATA:TELECOM:CHANNEL?  
Response: 1

**Related Commands** OUTPUT1:TELEcom:RATE  
SOURce:DATA:TELEcom:STRUcture

## SOURce:DATA:TELEcom:PAYLoad:MAPPING

This command sets or queries the payload mapping. The parameter changes the value in the C2 byte and fills the AU with the pattern selected by the SOURce:DATA:TELEcom:PAYLoad:PATtern command. Or, the AU can be filled with a tributary payload.

**Syntax** SOURce:DATA:TELEcom:PAYLoad:MAPPING <mapping>  
SOURce:DATA:TELEcom:PAYLoad:MAPPING?

Parameters	<mapping> (discrete)	Description
	EQUIpped	C2 Path Overhead byte is set to 01 (default)
	UNEQUIpped	C2 Path Overhead byte is set to 00
	TRIButary	Allows tributary payload mapping (Add/Drop Test Option Only)

**Dependencies** Select EQUIpped or UNEQUIpped to use the SOURce:DATA:PAYLoad:PATtern command. TRIButary is invalid for an AU-3 structure.

**Errors and Events** 221, "Settings conflict; Not available without tributary option"

**Examples**  
Set:       SOURCE:DATA:TELECOM:PAYLOAD:MAPPING EQUIPPED  
Query:     SOURCE:DATA:TELECOM:PAYLOAD:MAPPING?  
Response:  EQUIPPED

**Related Commands** None

## SOURce:DATA:TELEcom:PAYLoad:PATtern

This command sets or queries the test pattern to be placed in the payload of the active channel.

**Syntax** SOURce:DATA:TELEcom:PAYLoad:PATtern <pattern>  
SOURce:DATA:TELEcom:PAYLoad:PATtern?

Parameters	<pattern> (discrete)	Description
	PRBS23	A pseudo-random binary sequence of length $2^{23}-1$ is placed in the payload (default)
	PRBS9	A pseudo-random binary sequence of length $2^9-1$ is placed in the payload
	PRBS15	A pseudo-random binary sequence of length $2^{15}-1$ is placed in the payload
	PRBS20	A pseudo-random binary sequence of length $2^{20}-1$ is placed in the payload
	AZEROs	All zeros are placed in the payload
	AONEs	All ones are placed in the payload
	UBYTE	A user-defined byte is placed in the payload

**Dependencies** None

**Errors and Events** None

**Examples**  
Set:       SOURCE:DATA:TELECOM:PAYLOAD:PATTERN PRBS23  
Query:     SOURCE:DATA:TELECOM:PAYLOAD:PATTERN?  
Response:  PRBS15

**Related Commands**  
SOURce:DATA:TELEcom:PAYLoad  
SOURce:DATA:TELEcom:PAYLoad:PATtern:UBYTE

## SOURce:DATA:TELEcom:PAYLoad:PATtern:UBYTE

This command sets or queries the internally generated payload fixed pattern.

**Syntax** SOURce:DATA:TELEcom:PAYLoad:PATtern:UBYTE <fixed pattern>  
SOURce:DATA:TELEcom:PAYLoad:PATtern:UBYTE?

Parameters	<fixed pattern> (NR1-numeric) <sup>5</sup>	Description
	Any integer in the range 0 to 255 (hexadecimal 00 to FF)	The payload pattern is set to this value (default = 0)

<sup>5</sup> A hexadecimal value is also acceptable.

**Dependencies** SOURce:DATA:TELEcom:PAYLoad:PATtern must be set to UBYTE for this command to apply.

**Errors and Events** None

**Examples**

Set:       SOURCE:DATA:TELECOM:PAYLOAD:PATTERN:UBYTE 104

Query:     SOURCE:DATA:TELECOM:PAYLOAD:PATTERN:UBYTE?

Response:  88

**Related Commands** SOURce:DATA:TELEcom:PAYLoad:PATtern



## SOURce:DATA:TELEcom:OVERhead and POVerhead Subsystem

This section describes the commands and queries that set up the transport overhead and path overhead. Figure 2–12 shows the hierarchy tree for this subsystem.

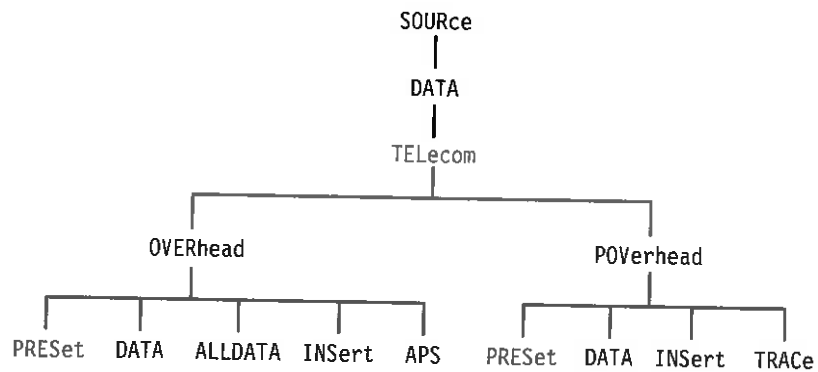

**Figure 2–12: SOURce:DATA:TELEcom:OVERhead and POVerhead subsystem**

Figure 2–14 lists the bytes in the Transport and Path Overhead and the value of each byte after a \*RST command is sent or a rate change occurs. As shown in Figure 2–13, each box can contain as many as three numbers: the overhead byte name in the upper left corner, the hexadecimal value of the byte at the bottom, and a circled number in the upper right corner. More information about these circled numbers is shown in the legend. General information is listed below the table in Notes.

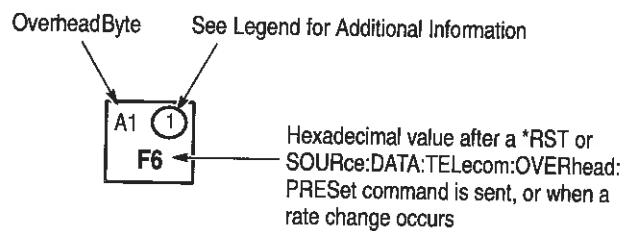

**Figure 2–13: How to read the overhead default values table**

STM-1 Transport Overhead									STM-0 Transport Overhead			Path Overhead
A1 F6	A1 F6	A1 F6	A2 28	A2 28	A2 28	C1 (1) 01	NU 00	NU 00	A1 F6	A2 28	C1 (6) 01	J1 (4) 00
B1 HW	- 00	- 00	E1 00	- 00	- 00	F1 00	NU 00	NU 00	B1 (7) HW	E1 00	F1 00	B3 HW
D1 00	- 00	- 00	D2 00	- 00	- 00	D3 00	- 00	- 00	D1 00	D2 00	D3 00	C2 (5) 00
H1 (2) HW	H1 93	H1 93	H2 (2) HW	H2 FF	H2 FF	H3 HW	H3 HW	H3 HW	H1 (3) HW	H2 (3) HW	H3 HW	G1 00
B2 HW	B2 HW	B2 HW	K1 00	- 00	- 00	K2 00	- 00	- 00	B2 HW	K1 00	K2 00	F2 00
D4 00	- 00	- 00	D5 00	- 00	- 00	D6 00	- 00	- 00	D4 00	D5 00	D6 00	H4 00
D7 00	- 00	- 00	D8 00	- 00	- 00	D9 00	- 00	- 00	D7 00	D8 00	D9 00	F3 00
D10 00	- 00	- 00	D11 00	- 00	- 00	D12 00	- 00	- 00	D10 00	D11 00	D12 00	K3 00
S1 00	- 00	- 00	- 00	- 00	M1 (3) 00	E2 00	NU 00	NU 00	S1 00	M1 00	E2 00	N1 00
Offset Value	0	1	2	0	1	2	0	1	2			

**Legend**

- ① C1 in STM-4 indicates the order of appearance of the STM-1 within the STM-4 frame. (SDH only)
- ② Default pointer value for H1 and H2 is hexadecimal 20A. The s-bits of H1 are set to 10. The n-bits of H1 are set to 0110. The default for H1 is 01101010. The default for H2 is 00001010.
- ③ The third M1 of an STM-1 can be set by hardware Line FEBE (determined by error rate and type).
- ④ The default for J1 is 64 nulls.
- ⑤ The C2 value is set by mapping.
- ⑥ See Bellcore Specification TR-NWT-000253 for a description.
- ⑦ Only the B1 byte in the first channel will be set by the hardware; the rest will be set to 0.

**Notes**

- All values are in hexadecimal.
- "NU" indicates a National Use Byte.
- "-" indicates an unnamed byte.
- "HW" indicates that the hexadecimal value is determined dynamically by the hardware.
- The offset value at the bottom of each column is used with the SOURCE:DATA:TELECOM:OVERHEAD:DATA and SENSE:DATA:TELECOM:OVERHEAD:DATA commands (concatenated structures only).
- For multiplexed signals, all bytes except B1, C1, and possibly M1 are duplicated.
- Only one path overhead exists for all SDH rates.
- When a rate change occurs, the overhead will be reset to the above default values.

Figure 2-14: SDH Overhead Default Values

## SOURce:DATA:TELEcom:OVERhead:PRESet

This command resets the entire overhead to the default (see Figure 2–14 on page 2–32 for the default values).

<b>Syntax</b>	SOURce:DATA:TELEcom:OVERhead:PRESet
<b>Parameters</b>	None
<b>Dependencies</b>	None
<b>Errors and Events</b>	None
<b>Examples</b>	SOURCE:DATA:TELECOM:OVERHEAD:PRESET
<b>Related Commands</b>	SOURce:DATA:TELEcom:OVERhead:DATA

## SOURce:DATA:TELEcom:OVERhead:DATA

This command sets or queries the bytes in the transport overhead. Bytes B1, B2, B3, H1, H2, and H3 are not accessible because they are controlled directly by the hardware.

Use <channel>, <byte>, and <offset> to address all named and unnamed bytes in the concatenated structures.

Use the <offset> parameter to set unnamed or ambiguous bytes in concatenated structures (STM-1). See Figure 2–14 for the offset values.

**Syntax** SOURce:DATA:TELEcom:OVERhead:DATA <channel>,<byte>,<offset>,<value>  
SOURce:DATA:TELEcom:OVERhead:DATA? <channel>,<byte>,<offset>

Parameters	<channel> (NR1-numeric)	description
	1	Rate is STM-0 or STM-1
	1 to 4	Rate is STM-4
	<byte> (discrete)	description
	A1, A2, C1, E1, F1, D1, D2, D3, K1, K2, D4, D5, D6, D7, D8, D9, D10, D11, D12, S1, M1, E2	Only the bytes listed are available for selection
	<offset> (NR1-numeric)	description
	0 to 2	All SDH rates
	<value> (NR1-numeric) <sup>6</sup>	description
	Any integer in the range 0 to 255 (hexadecimal 00 to FF)	The byte is set to this value

<sup>6</sup> A hexadecimal value is also acceptable.

**Dependencies** None

**Errors and Events** None

**Examples**

Set: SOURCE:DATA:TELECOM:OVERHEAD:DATA 4,D5,2,#H55

Sets the D5 byte in the fourth overhead of an STM-4 signal to hexadecimal 55.

Query: SOURCE:DATA:TELECOM:OVERHEAD:DATA? 1,C1,0

Response: 255

**Related Commands** None

## SOURce:DATA:TELEcom:OVERhead:ALLData

The command form sets all overhead bytes at one time.

This query form returns overhead data in a command form that can be used to set the available overhead bytes. One command with 24 parameters is produced. The first two parameters indicate channel and offset. The remaining 22 parameters are the data values for the overhead bytes in decimal number form.

**Syntax** SOURce:DATA:TELEcom:OVERhead:ALLDATA <channel>,<offset>,<A1>,<A2>,<C1>,<E1>,<F1>,<D1>,<D2>,<D3>,<K1>,<K2>,<D4>,<D5>,<D6>,<D7>,<D8>,<D9>,<D10>,<D11>,<D12>,<S1>,<M1>,<E2>  
SOURce:DATA:TELEcom:OVERhead:ALLData? <channel>,<offset>

Parameters	<channel> (NR1-numeric)	description
	Any integer in the range 1 to 12	This value indicates the desired channel setting
Parameters	<offset> (NR1-numeric)	description
	Any integer in the range 0 to 2	This value indicates the desired offset
Parameters	<A1>,<A2>,<C1>,<B1>,<E1>,<F1>,<D1>,<D2>,<D3>,<H1>,<H2>,<H3>,<B2>,<K1>,<K2>,<D4>,<D5>,<D6>,<D7>,<D8>,<D9>,<D10>,<D11>,<D12>,<S1>,<M1>,<E2> (NR1-numeric) <sup>1</sup>	description
	Any integer in the range 0 to 255 for each parameter (hexadecimal 00 to FF)	These values indicate the desired setting for each overhead byte

<sup>1</sup> A hexadecimal value is also acceptable.

**Dependencies** <channel> and <offset> must be compatible with the current rate and structure settings.

**Errors and Events** 221, "Settings conflict; Parameter out of range"  
118, "Query not allowed"

**Examples** Set: SOURCE:DATA:TELECOM:OVER:ALLDATA  
1,0,92,123,1,0,23,0,0,0,0,0,  
0,0,0,0,0,0,0,0,0,0,0,0

The above example sets the A1 byte to 92, the A2 byte to 123, the C1 byte to 1, the E1 byte to 23, and the rest of the bytes to 0 for channel 1.

Query: SOURCE:DATA:TELECOM:OVERHEAD:ALLDATA? 1,0

Response: SOURCE:DATA:TELECOM:OVERHEAD:ALLDATA 1, 0, 92, 123, 1,  
0, 23, 0, 0, 0, 0, 0, 0, 0, 0, 0, 0, 0, 0, 0, 0, 0, 0,  
0

**Related Commands** SOURce:DATA:TELEcom:OVERhead:DATA

## SOURce:DATA:TELEcom:OVERhead:INSert

This command sets or queries the insertion of data into the overhead from an external protocol analyzer into the specific overhead bytes.

**Syntax** SOURce:DATA:TELEcom:OVERhead:INSert <insert>  
SOURce:DATA:TELEcom:OVERhead:INSert?

### Parameters

<insert> (discrete)	description
NONE	Off (default)
SDCC	RS DCC
LDCC	MS DCC
F1	F1 byte

**Dependencies** You can insert data into the overhead or the path overhead by using the SOURce:DATA:TELEcom:OVERhead:INSert and SOURce:DATA:TELEcom:POVerhead:INSert commands. The last command sent applies.

**Errors and Events** None

**Examples** Set: SOURCE:DATA:TELECOM:OVERHEAD:INSERT SDCC  
 Query: SOURCE:DATA:TELECOM:OVERHEAD:INSERT?  
 Response: F1

**Related Commands** None

## SOURce:DATA:TELEcom:OVERhead:APS

This command sets or queries the K1 and K2 16-bit bytes in the same frame. Use the SENSE:DATA:TELEcom:OVERhead:DATA? query to find out the value of the K1 and K2 bytes in the received signal.

**Syntax** SOURce:DATA:TELEcom:OVERhead:APS <APS value>  
 SOURce:DATA:TELEcom:OVERhead:APS?

### Parameters

<APS value> (NR1-numeric) <sup>1</sup>	description
Any integer in the range 0 to 65535 (hexadecimal 0 to FFFF)	The 16-bit value of the K1 and K2 MSP bytes

<sup>1</sup> A hexadecimal value is also acceptable.

**Dependencies** None

**Errors and Events** None

**Examples** Set: SOURCE:DATA:TELECOM:OVERHEAD:APS #HFFFF  
 The above example sets both K1 and K2 bytes to the maximum value (binary 1111111111111111).

Set: SOURCE:DATA:TELECOM:OVERHEAD:APS #HFF00

The above example sets the K1 byte to the maximum value (binary 11111111) and the K2 byte to 0 (binary 00000000).

Query: SOURCE:DATA:TELECOM:OVERHEAD:APS?

Response: 65535

**Related Commands** None

## SOURce:DATA:TELEcom:POVerhead:PRESet

This command resets the path overhead to the default (see Figure 2–14 on page 2–32 for the default values).

<b>Syntax</b>	SOURce:DATA:TELEcom:POVerhead:PRESet
<b>Parameters</b>	None
<b>Dependencies</b>	None
<b>Errors and Events</b>	None
<b>Examples</b>	SOURCE:DATA:TELECOM:POVERHEAD:PRESET
<b>Related Commands</b>	SOURce:DATA:TELEcom:POVerhead:DATA

## SOURce:DATA:TELEcom:POVerhead:DATA

This command sets or queries the bytes in the path overhead.

**Syntax** SOURce:DATA:TELEcom:POVerhead:DATA <byte>,<value>  
 SOURce:DATA:TELEcom:POVerhead:DATA? <byte>

<b>Parameters</b>	<b>&lt;byte&gt; (discrete)</b>	<b>description</b>
	C2, F2, F3, K3, N1	Only the bytes listed are available for selection <sup>1</sup>
	<b>&lt;value&gt; (NR1-numeric)<sup>2</sup></b>	<b>description</b>
	Any integer in the range 0 to 255 (hexadecimal 00 to FF)	The selected byte is set to this value

<sup>1</sup> The J1 path trace overhead byte is controlled through the SOURce:DATA:TELEcom:POVerhead:TRACe command.

<sup>2</sup> A hexadecimal value is also acceptable.



<b>Dependencies</b>	This command is ignored if <code>SOURCE:DATA:TELECOM:POVerhead:INSert</code> is set to F2.
<b>Errors and Events</b>	None
<b>Examples</b>	Set: <code>SOURCE:DATA:TELECOM:POVERHEAD:DATA D1,#H55</code> Query: <code>SOURCE:DATA:TELECOM:POVERHEAD:DATA? C2</code> Response: 255
<b>Related Commands</b>	<code>SOURCE:DATA:TELECOM:POVerhead:TRACe</code> <code>SOURCE:DATA:TELECOM:PAYLoad:MAPPing</code> (sets the C2 byte)

## `SOURCE:DATA:TELECOM:POVerhead:INSert`

This command sets or queries the path overhead data from an external protocol analyzer into the specific overhead bytes.

<b>Syntax</b>	<code>SOURCE:DATA:TELECOM:POVerhead:INSert &lt;path insert&gt;</code> <code>SOURCE:DATA:TELECOM:POVerhead:INSert?</code>						
<b>Parameters</b>	<table border="1"> <thead> <tr> <th>&lt;path insert&gt; (discrete)</th> <th>description</th> </tr> </thead> <tbody> <tr> <td>NONE</td> <td>Off</td> </tr> <tr> <td>F2</td> <td>F2 byte</td> </tr> </tbody> </table>	<path insert> (discrete)	description	NONE	Off	F2	F2 byte
<path insert> (discrete)	description						
NONE	Off						
F2	F2 byte						
<b>Dependencies</b>	You can insert data into the overhead or the path overhead by using the <code>SOURCE:DATA:TELECOM:OVERhead:INSert</code> and <code>SOURCE:DATA:TELECOM:POVerhead:INSert</code> commands. The last command sent applies.						
<b>Errors and Events</b>	None						
<b>Examples</b>	Set: <code>SOURCE:DATA:TELECOM:POVERHEAD:INSERT F2</code> Query: <code>SOURCE:DATA:TELECOM:POVERHEAD:INSERT?</code> Response: NONE						
<b>Related Commands</b>	None						

## SOURce:DATA:TELEcom:POVerhead:TRACe

This command sets or queries the path trace overhead bytes that appear in J1 as a repeating 64-byte sequence. The string must not exceed 64 ASCII characters in length. Unprintable characters will be accepted and inserted directly.

**Syntax** SOURce:DATA:TELEcom:POVerhead:TRACe <path trace>  
SOURce:DATA:TELEcom:POVerhead:TRACe?

Parameters	<path trace> (string)	description
	Length is a maximum of 64 bytes; if length is less than 64 bytes, the buffer is padded with nulls to a length of 64 bytes; the string will be terminated with a CR/LF (carriage return/line feed)	The J1 byte is set to this value (default is 64 null characters)

**Dependencies** None

**Errors and Events** 223, "Too much data; Path trace string truncated"

**Examples**  
 Set:       SOURCE:DATA:TELECOM:POVERHEAD:TRACE "TESTING 1 . 2 . 3"  
 Query:     SOURCE:DATA:TELECOM:POVERHEAD:TRACE?  
 Response: "THIS IS A TEST"

**Related Commands** SOURce:DATA:TELEcom:POVerhead:DATA?

## SOURce:DATA:TELEcom:ERRor, ALARm, and FAILure Subsystem

This section describes the commands and queries that control abnormal conditions such as errors, alarms, and failures in the transmitted signal. Figure 2–15 shows the hierarchy tree for this subsystem.

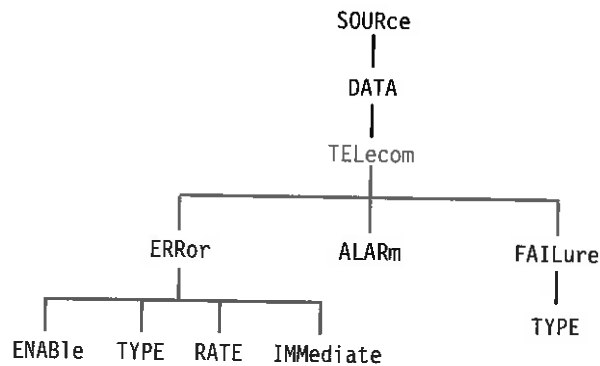

Figure 2–15: SOURce:DATA:TELEcom:ERRor, ALARm, and FAILure subsystem

### SOURce:DATA:TELEcom:ERRor:ENABLe

This command sets or queries output signal error insertion.

**Syntax** SOURce:DATA:TELEcom:ERRor:ENABLe <error rate state>  
SOURce:DATA:TELEcom:ERRor:ENABLe?

Parameters	<error rate state> (boolean)	Description
	0 or OFF	Error rate disabled (default)
	1 or ON	Errors specified by rate

**Dependencies** None

**Errors and Events** None

**Examples**

Set:       SOURCE:DATA:TELECOM:ERROR:ENABLE 0

Query:     SOURCE:DATA:TELECOM:ERROR:ENABLE?

Response:  1

**Related Commands**    `SOURce:DATA:TELEcom:ERRor:RATE`  
`SOURce:DATA:TELEcom:ERRor:MODE`

## **SOURce:DATA:TELEcom:ERRor:TYPE**

This command sets or queries the error type.

**Syntax**    `SOURce:DATA:TELEcom:ERRor:TYPE <error type>`  
`SOURce:DATA:TELEcom:ERRor:TYPE?`

**Parameters**

<b>&lt;error type&gt; (discrete)</b>	<b>Description</b>
SCV	RS B1 BIP error; B1 will be errored across all bits (default)
LCV	MS B2 BIP error; B2 will be errored across all bits
PCV	Path B3 BIP error; the active channel B3 will be errored across all bits
PFEBE	Path Far End Block Error (path FEBE at specified rate); a value of 1 is inserted in the G1 byte when the <code>SOURce:DATA:TELEcom:ERRor:IMMEDIATE</code> command is given
DATA	Payload data bit error (payload data will be errored but B3 will not)
TRIButary	Allows selection of tributary errors (Add/Drop Test Option Only)

**Dependencies**    None

**Errors and Events**    None

**Examples**

Set:        `SOURCE:DATA:TELECOM:ERROR:TYPE SCV`

Query:     `SOURCE:DATA:TELECOM:ERROR:TYPE?`

Response: `DATA`

**Related Commands**    `SOURce:DATA:TELEcom:ERRor:RATE`  
`SOURce:DATA:TELEcom:TRIButary:ERRor`

## SOURce:DATA:TELEcom:ERRor:RATE

This command sets or queries the error rate. Resolution is limited to one digit. For example, 1E-6, 2E-9, and 1E-3 are valid values; 1.43E-4 and 2.7E-9 are not valid values. Invalid error rates will be changed to the nearest valid value. For example, 1.25E-5 (too many digits) will be changed to 1E-5, 1E-20 (below minimum) will be changed to 1E-10 (minimum), and 1 (above maximum) will be changed to 1E-3 (maximum).

To disable error generation at any specified rate, use the SOURce:DATA:TELEcom:ERRor:ENABle OFF command.

**Syntax** SOURce:DATA:TELEcom:ERRor:RATE <error rate>  
 SOURce:DATA:TELEcom:ERRor:RATE?  
 (see Tables 2-5 and 2-6 for <error rate> parameters)

**Table 2-5: Error insertion rate limits for SOURce:DATA:TELEcom:ERRor:RATE**

If rate set to:	If error type set to SCV	If error type set to LCV	If error type set to PCV	If error type set to PFEBE	If error type set to DATA
STM0	1E-10 to 1E-3	1E-10 to 1E-3	1E-10 to 1E-3	1E-10 to 1E-3	1E-10 to 1E-3
STM1	1E-10 to 1E-4	1E-10 to 1E-4	1E-10 to 1E-4	1E-10 to 1E-4	1E-10 to 1E-3
STM4	1E-10 to 1E-5	1E-10 to 1E-4	1E-10 to 1E-4	1E-10 to 1E-4	1E-10 to 1E-3

The table lists the minimum and maximum rates.

All error rates are NR3-numeric.

**Table 2-6: Error insertion rate limits for SOURce:DATA:TELEcom:ERRor:RATE (Add/Drop Test Option Only)**

If rate set to:	If error type set to TUBIP	If error type set to TUFEBE	If error type set to CRC	If error type set to FRAME	If error type set to DATA
M2	1E-10 to 1E-4	1E-10 to 1E-4	1E-8 to 1E-4	1E-7 to 1E-2	1E-8 to 1E-2
M34	1E-10 to 1E-4	1E-10 to 1E-4	not applicable	1E-7 to 1E-2	1E-9 to 1E-2
M140	not applicable	not applicable	not applicable	1E-8 to 1E-2	1E-9 to 1E-2

The table lists the minimum and maximum rates.

All error rates are NR3-numeric.

**Dependencies** None

**Errors and Events** 500, "Execution warning; Numeric value greater than maximum limit"  
 500, "Execution warning; Numeric value less than minimum limit"

**Examples** Set: SOURCE:DATA:TELECOM:ERROR:RATE 1E-6  
 Query: SOURCE:DATA:TELECOM:ERROR:RATE?  
 Response: 1E-10

**Related Commands** SOURCE:DATA:TELECOM:ERROR:RATE  
 SOURCE:DATA:TELECOM:ERROR:TYPE  
 SOURCE:DATA:TELECOM:TRIBUTARY:ERROR

## SOURCE:DATA:TELECOM:ERROR:IMMEDIATE

This command is used to force an error insertion. The error is defined by SOURCE:DATA:TELECOM:DATA:ERROR:TYPE.

**Syntax** SOURCE:DATA:TELECOM:ERROR:IMMEDIATE

**Parameters** None

**Dependencies** SOURCE:DATA:TELECOM:ERROR:ENABLE must be set to ON.

**Errors and Events** None

**Examples** SOURCE:DATA:TELECOM:ERROR:IMMEDIATE

**Related Commands** SOURCE:DATA:TELECOM:ERROR:TYPE  
 SOURCE:DATA:TELECOM:TRIBUTARY:ERROR

## SOURce:DATA:TELEcom:ALARm

This command sets or queries the transmit alarm type.

**Syntax** SOURce:DATA:TELEcom:ALARm <alarm>  
SOURce:DATA:TELEcom:ALARm?

### Parameters

<alarm> (discrete)	Description
NONE	No alarms (default)
LAIS	MS AIS
PAIS	Path AIS
LFERf	MS FERF
PFERf	Path FERF
TRIButary	Allows selection of tributary alarms (Add/Drop Test Option Only)

**Dependencies** SOURce:DATA:TELEcom:FAILure:TYPE must be set to NONE for this command to apply.

**Errors and Events** None

**Examples**  
Set:       SOURCE:DATA:TELECOM:ALARM LAIS  
Query:     SOURCE:DATA:TELECOM:ALARM?  
Response:  PFERF

**Related Commands** SOURce:DATA:TELEcom:TRIButary:ALARm

## SOURce:DATA:TELEcom:FAILure:TYPE

This command sets or queries the transmit failure type. Selecting a failure type overrides all errors and alarms.

**Syntax** SOURce:DATA:TELEcom:FAILure:TYPE <failure>  
 SOURce:DATA:TELEcom:FAILure:TYPE?

Parameters	<failure> (discrete)	Description
	NONE	No failures (default)
	LOSignal	Loss of Signal (disconnects the output signal)
	LOFrame	Loss of Frame (changes the most significant bit of A1 resulting in a hexadecimal value of 76)
	LOPointer	Loss of Pointer (generates continuous NDFs)
	TRIButary	Allows selection of tributary failures (Add/Drop Test Option Only)

**Dependencies** None

**Errors and Events** None

**Examples**  
 Set:       SOURCE:DATA:TELECOM:FAILURE:TYPE LOS  
 Query:     SOURCE:DATA:TELECOM:FAILURE:TYPE?  
 Response:  NONE

**Related Commands** SOURce:DATA:TELEcom:TRIButary:FAILure



## SOURce:DATA:TELeom:POINter Subsystem

This section describes the commands and queries that adjust pointers. Figure 2–16 shows the hierarchy tree for this subsystem.

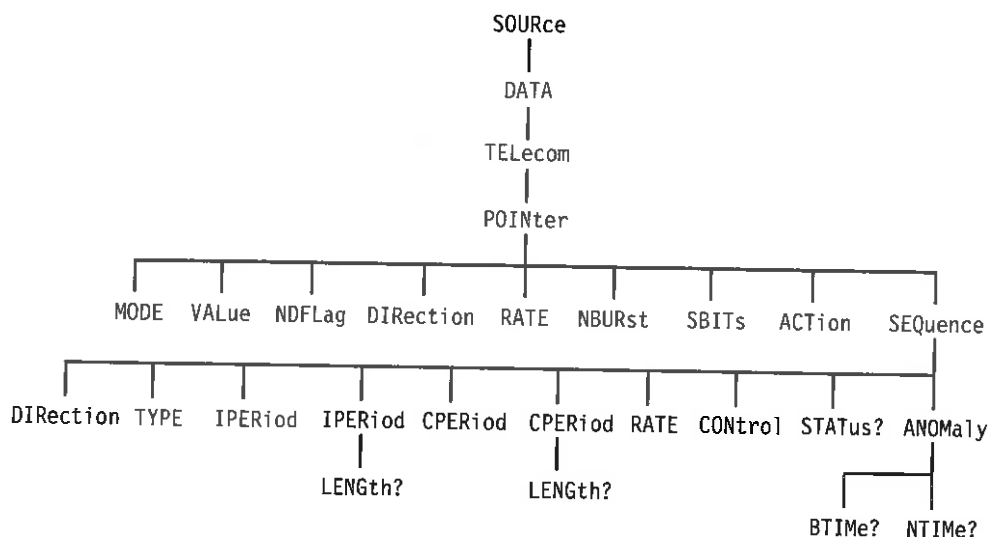

Figure 2–16: SOURce:DATA:TELeom:POINter subsystem

## SOURce:DATA:TELeom:POINter:MODE

This command sets or queries the pointer manipulation modes.

**Syntax** SOURce:DATA:TELeom:POINter:MODE <mode>  
 SOURce:DATA:TELeom:POINter:MODE?

Parameters	<mode> (discrete)	Description
	MANual	Pointers are controlled by SOURce:DATA:TELeom:POINter:VALue and SOURce:DATA:TELeom:NDFlag (default)
	SINGle	When the SOURce:DATA:TELeom:POINter:ACTIon command is given, pointer adjustments will alternately increment and decrement

(continued on next page)

<b>&lt;mode&gt; (discrete)</b>	<b>Description</b>
BURSt	When the SOURce:DATA:TELeom:POINter:ACTion command is given, a burst of pointer adjustments is sent at the maximum rate (1 in 4 frames) and with a count defined by SOURce:DATA:TELeom:POINter:NBURst
FOFFset	Frequency offset pointers are controlled by the SOURce:CLOCK:OFFSet: commands
CONTinuous	Pointers are continuously adjusted according to the SOURce:DATA:TELeom:POINter:RATE and SOURce:DATA:TELeom:POINter:DIRection commands
TRIButary	Pointers are controlled by the SOURce:DATA:TELeom:TRIButary:POINter subsystem (Add/Drop Test Option Only)
SEQuence	Pointers are stressed according to sequences defined in T1.105.03–1994 or G.783.

**Dependencies**    None

**Errors and Events**    None

**Examples**

Set:            SOURCE:DATA:TELECOM:POINTER:MODE FOFFSET

Query:        SOURCE:DATA:TELECOM:POINTER:MODE?

Response:    SEQUENCE

**Related Commands**    None

## SOURce:DATA:TELEcom:POINter:VALue

This command sets or queries the pointer value. To obtain an illegal pointer value, use a value greater than 782. If SOURce:DATA:TELEcom:POINter:NDFlag is set to ON, a New Data Flag (NDF) is sent with each new value received.

**Syntax** SOURce:DATA:TELEcom:POINter:VALue <pointer value>  
SOURce:DATA:TELEcom:POINter:VALue?

Parameters	<pointer value> (NR1-numeric)	Description
	Any integer in the range 0 to 1023	Pointer set to this value (default = 522)

**Dependencies** SOURce:DATA:TELEcom:POINter:MODE must be set to MANUAL for this command to apply.

**Errors and Events** None

**Examples**  
Set:       SOURCE:DATA:TELECOM:POINTER:VALUE 10  
Query:     SOURCE:DATA:TELECOM:POINTER:VALUE?  
Response:  412.

**Related Commands** SOURce:DATA:TELEcom:POINter:MODE  
SOURce:DATA:TELEcom:POINter:NDFlag

## SOURce:DATA:TELEcom:POINter:NDFLag

This command sets or queries the generation of a New Data Flag (NDF) when pointer adjustments occur.

**Syntax** SOURce:DATA:TELEcom:POINter:NDFLag <NDF state>

Parameters	<NDF state> (boolean)	Description
	1 or ON	On (default)
	0 or OFF	Off

**Dependencies** SOURCE:DATA:TELEcom:POINter:MODE must be set to MANual for this command to apply.

**Errors and Events** None

**Examples**  
 Set: SOURCE:DATA:TELECOM:POINTER:NDFLag ON  
 Query: SOURCE:DATA:TELECOM:POINTER:NDFLag?  
 Response: 1

**Related Commands** SOURCE:DATA:TELEcom:POINter:VALue

## SOURCE:DATA:TELEcom:POINter:DIRection

This command sets or queries the continuous pointer adjustment direction.

**Syntax** SOURCE:DATA:TELEcom:POINter:DIRection <direction>  
 SOURCE:DATA:TELEcom:POINter:DIRection?

Parameters	<direction> (discrete)	Description
	ALternate	Pointer adjustments alternate between up and down (default)
	DOWN	Pointers adjusted down
	UP	Pointers adjusted up

**Dependencies** SOURCE:DATA:TELEcom:POINter:MODE must be set to CONTInuous for this command to apply.

**Errors and Events** None

**Examples**  
 Set: SOURCE:DATA:TELECOM:POINTER:DIRECTION UP  
 Query: SOURCE:DATA:TELECOM:POINTER:DIRECTION?  
 Response: DOWN

**Related Commands** SOURCE:DATA:TELEcom:POINter:RATE

## SOURce:DATA:TELEcom:POINter:RATE

This command sets or queries the continuous pointer adjustment rate.

**Syntax** SOURce:DATA:TELEcom:POINter:RATE <rate>  
SOURce:DATA:TELEcom:POINter:RATE?

Parameters	<rate> (NR1-numeric)	Description
	Any integer in the range 2 to 10,000 ms (resolution of 1 ms)	The pointer adjustment rate is set to this value

**Dependencies** SOURce:DATA:TELEcom:POINter:MODE must be set to CONTInuous for this command to apply.

**Errors and Events** None

**Examples**  
Set:       SOURCE:DATA:TELECOM:POINTER:RATE 10  
Query:     SOURCE:DATA:TELECOM:POINTER:RATE?  
Response:  4

**Related Commands** SOURce:DATA:TELEcom:POINter:DIRection  
SOURce:DATA:TELEcom:POINter:MODE

## SOURce:DATA:TELEcom:POINter:NBURst

This command sets or queries the number of pointer adjustments in a burst of pointer adjustments. The SOURce:DATA:TELEcom:POINter:ACTion command controls when the burst occurs.

**Syntax** SOURce:DATA:TELEcom:POINter:NBURst <pointer burst number>  
SOURce:DATA:TELEcom:POINter:NBURst?

Parameters	<pointer burst number> (NR1-numeric)	Description
	Any integer in the range 2 to 8	This value determines the number of pointer adjustments in a burst of pointer adjustments (default = 2)

<b>Dependencies</b>	SOURce:DATA:TELEcom:POINter:MODE must be set for BURSt for this command to apply.
<b>Errors and Events</b>	None
<b>Examples</b>	Set: SOURCE:DATA:TELECOM:POINTER:NBURST 2 Query: SOURCE:DATA:TELECOM:POINTER:NBURST? Response: 4
<b>Related Commands</b>	SOURce:DATA:TELEcom:POINter:MODE SOURce:DATA:TELEcom:POINter:ACTion

## SOURce:DATA:TELEcom:POINter:SBITs

This command sets or queries the static value of the S-bits (bits 5 and 6) in the H1 byte.

<b>Syntax</b>	SOURce:DATA:TELEcom:POINter:SBITs <pointer sbits> SOURce:DATA:TELEcom:POINter:SBITs?				
<b>Parameters</b>	<table border="1" style="width: 100%; border-collapse: collapse;"> <thead> <tr> <th style="text-align: left; padding: 5px;">&lt;pointer sbits&gt; (NR1-numeric)</th> <th style="text-align: left; padding: 5px;">Description</th> </tr> </thead> <tbody> <tr> <td style="padding: 5px;">Any integer in the range 0 to 3</td> <td style="padding: 5px;">This value is the S-bit in the H1 byte (default = binary 10)</td> </tr> </tbody> </table>	<pointer sbits> (NR1-numeric)	Description	Any integer in the range 0 to 3	This value is the S-bit in the H1 byte (default = binary 10)
<pointer sbits> (NR1-numeric)	Description				
Any integer in the range 0 to 3	This value is the S-bit in the H1 byte (default = binary 10)				
<b>Dependencies</b>	None				
<b>Errors and Events</b>	500, "Execution warning; Numeric value greater than maximum limit"				
<b>Examples</b>	Set: SOURCE:DATA:TELECOM:POINTER:SBITS 0 Query: SOURCE:DATA:TELECOM:POINTER:SBITS? Response: 2				
<b>Related Commands</b>	None				

## SOURce:DATA:TELEcom:POINter:ACTion

This command invokes a pointer adjustment for SDH or tributary signals.

<b>Syntax</b>	SOURce:DATA:TELEcom:POINter:ACTion
<b>Parameters</b>	None
<b>Dependencies</b>	SOURce:DATA:TELEcom:POINter:MODE or if the SOURce:DATA:TELEcom:POINter:MODE is TRIButary, SOURce:DATA:TELEcom:TRIButary:POINter:MODE must be set to SINGLE or BURst for this command to apply.
<b>Errors and Events</b>	221, "Settings conflict; Mode must be single or burst" 200, "Execution error; Pointer burst active, request ignored"
<b>Examples</b>	SOURCE:DATA:TELECOM:POINTER:ACTION
<b>Related Commands</b>	SOURce:DATA:TELEcom:POINter:MODE SOURce:DATA:TELEcom:POINter:NBURst SOURce:DATA:TELEcom:TRIButary:POINter:MODE SOURce:DATA:TELEcom:TRIButary:POINter:NBURst

## SOURce:DATA:TELEcom:POINter:SEQuence:DIRection

This command sets or queries the pointer sequence movement direction.

Setting this parameter when a sequence is running returns an error.

<b>Syntax</b>	SOURce:DATA:TELEcom:POINter:SEQuence:DIRection <ptr seq dir> SOURce:DATA:TELEcom:POINter:SEQuence:DIRection?							
<b>Parameters</b>	<table border="1"> <thead> <tr> <th>&lt;ptr seq dir&gt; (discrete)</th> <th>Description</th> </tr> </thead> <tbody> <tr> <td>DOWN</td> <td></td> </tr> <tr> <td>UP</td> <td>(default)</td> </tr> </tbody> </table>		<ptr seq dir> (discrete)	Description	DOWN		UP	(default)
<ptr seq dir> (discrete)	Description							
DOWN								
UP	(default)							

**Dependencies** Pointer sequences must not be running.

**Errors and Events** 221, “Settings conflict”

**Examples**  
 Set: SOURCE:DATA:TELECOM:POINTER:SEQUENCE:DIRECTION UP  
 Query: SOURCE:DATA:TELECOM:POINTER:SEQUENCE:DIRECTION?  
 Response: DOWN

**Related Commands** SOURCE:DATA:TELECOM:POINTER:MODE  
 SOURCE:DATA:TELECOM:POINTER:SEQUENCE:CONTROL

## SOURCE:DATA:TELECOM:POINTER:SEQUENCE:RATE

This command sets or queries the pointer sequence movement rate in milliseconds.

Setting this parameter when a sequence is running returns an error.

**Syntax** SOURCE:DATA:TELECOM:POINTER:SEQUENCE:RATE <ptr seq rate>  
 SOURCE:DATA:TELECOM:POINTER:SEQUENCE:RATE?

**Parameters**

<ptr seq rate> (NR1-numeric)	Description
Any integer in the range 34 to 30,000 ms	Resolution is 1 ms (default = 34 ms)

**Dependencies** Pointer sequences must not be running. Some sequence types (such as single, burst, phase, sinalt, and dblalt) set the rate to 30,000 ms. With these types, you cannot change the rate.

**Errors and Events** 221, “Settings conflict; Not available without jitter option”

**Examples**  
 Set: SOURCE:DATA:TELECOM:POINTER:SEQUENCE:RATE 50  
 Query: SOURCE:DATA:TELECOM:POINTER:SEQUENCE:RATE?  
 Response: 34

**Related Commands** SOURCE:DATA:TELECOM:POINTER:MODE  
 SOURCE:DATA:TELECOM:POINTER:SEQUENCE:CONTROL  
 SOURCE:DATA:TELECOM:POINTER:SEQUENCE:TYPE



## SOURce:DATA:TELEcom:POINter:SEQuence:TYPE

This command sets or queries the pointer sequence type.

Setting this parameter when a sequence is running returns an error.

**Syntax** SOURce:DATA:TELEcom:POINter:SEQuence:TYPE <ptr seq type>  
SOURce:DATA:TELEcom:POINter:SEQuence:TYPE?

Parameters	<pointer seq type> (discrete)	Description
	SINGle	Single pointer adjustment (G.783 e)
	BURSt	Burst pointer adjustment (G.783 f)
	PHASE	Phase transient pointer adjustment
	P873	Periodic 87-3 pointer adjustment (G.783 g1)
	P873CAN	Periodic 87-3 with cancel (G.783 g3)
	P873ADD	Periodic 87-3 with add (G.783 g2)
	PCONtinuous	Periodic continuous pointer adjustment (G.783 h1)
	PCONCAN	Periodic continuous with cancel (G.783 h3)
	PCONADD	Periodic continuous with add (G.783 h2)
	REGDBL	Regular pointer plus one double (G.783 b)
	REGMIS	Regular pointer with one missing (G.783 c)
	SINALT	Single alternating pointer (G.783 a)
	DBLALT	Double alternating pointer (G.783 d)

**Dependencies** Pointer sequences must not be running.

G.783 applies only to SDH rates.

**Errors and Events** 221, "Settings conflict; stop sequences before setting the type"

**Examples**    Set:        SOURCE:DATA:TELECOM:POINTER:SEQUENCE:TYPE BURST  
                   Query:        SOURCE:DATA:TELECOM:POINTER:SEQUENCE:TYPE?  
                   Response: SINALT

**Related Commands**    SOURCE:DATA:TELECOM:POINTER:MODE  
                               SOURCE:DATA:TELECOM:POINTER:SEQUENCE:CONTROL

## SOURCE:DATA:TELECOM:POINTER:SEQUENCE:IPERIOD

This command sets or queries the pointer sequence initialization period.  
 Setting this parameter when a sequence is running returns an error.

**Syntax**        SOURCE:DATA:TELECOM:POINTER:SEQUENCE:IPERIOD <ptr seq init>  
                   SOURCE:DATA:TELECOM:POINTER:SEQUENCE:IPERIOD?

Parameters	<ptr seq init> (discrete)	Description
	0 (or OFF)	Disables the pointer sequence initialization period
	1 (or ON)	Enables the pointer sequence initialization period (default)

**Dependencies**    Pointer sequences must not be running.

**Errors and Events**    221, "Settings conflict; Not available without jitter option"

**Examples**        Set:        SOURCE:DATA:TELECOM:POINTER:SEQUENCE:IPERIOD ON  
                   Query:        SOURCE:DATA:TELECOM:POINTER:SEQUENCE:IPERIOD?  
                   Response: 0

**Related Commands**    SOURCE:DATA:TELECOM:POINTER:MODE  
                               SOURCE:DATA:TELECOM:POINTER:SEQUENCE:CONTROL

**SOURce:DATA:TELEcom:POINter:SEQuence:IPERiod:LENGth?**

This query returns the pointer sequence initialization period in seconds.

**Syntax** SOURce:DATA:TELEcom:POINter:SEQuence:IPERiod:LENGth?

Response	<pointer seq init> (NR1-numeric)	Description
	Any integer	Pointer sequence initialization period in seconds

**Dependencies** None

**Errors and Events** None

**Examples** Query: SOURCE:DATA:TELECOM:POINTER:SEQUENCE:IPERIOD:LENGTH?  
Response: 30

**Related Commands** SOURce:DATA:TELEcom:POINter:SEQuence:IPERiod  
SOURce:DATA:TELEcom:POINter:SEQuence:RATE  
SOURce:DATA:TELEcom:POINter:SEQuence:TYPE

**SOURce:DATA:TELEcom:POINter:SEQuence:CPEriod**

This command sets or queries the pointer sequence cool down period.

Setting this parameter when a sequence is running returns an error.

**Syntax** SOURce:DATA:TELEcom:POINter:SEQuence:CPEriod <ptr seq init>  
SOURce:DATA:TELEcom:POINter:SEQuence:CPEriod?

Parameters	<pointer seq init> (discrete)	Description
	0 (or OFF)	Disables the pointer sequence cool down period
	1 (or ON)	Enables the pointer sequence cool down period (default)

- Dependencies** Pointer sequences must not be running.
- Errors and Events** 221, "Settings conflict; Not available without jitter option"
- Examples**  
 Set: SOURCE:DATA:TELECOM:POINTER:SEQUENCE:CPERIOD OFF  
 Query: SOURCE:DATA:TELECOM:POINTER:SEQUENCE:CPERIOD?  
 Response: 1
- Related Commands** SOURce:DATA:TELEcom:POINter:MODE  
 SOURce:DATA:TELEcom:POINter:SEQuence:CONTRol

## SOURce:DATA:TELEcom:POINter:SEQuence:CPERiod:LENGth?

This query returns the pointer sequence cool down period in seconds.

- Syntax** SOURce:DATA:TELEcom:POINter:SEQuence:CPERiod:LENGth?
- Response**
- | <pointer seq init> (NR1-numeric) | Description                                  |
|----------------------------------|--|
| Any integer                      | Pointer sequence cool down period in seconds |

- Dependencies** None
- Errors and Events** None
- Examples**  
 Query: SOURCE:DATA:TELECOM:POINTER:SEQUENCE:CPERIOD:LENGTH  
 Response: 675
- Related Commands** SOURce:DATA:TELEcom:POINter:SEQuence:CPERiod  
 SOURce:DATA:TELEcom:POINter:SEQuence:RATE  
 SOURce:DATA:TELEcom:POINter:SEQuence:TYPE

## SOURce:DATA:TELEcom:POINter:SEQUEnce:CONTrol

This command sets or queries the pointer sequences and tributary pointer sequences.

A sequence begins with an initialization or cool down period, if enabled, and then enters operation. You may stop a pointer sequence at any time.

**Syntax** SOURce:DATA:TELEcom:POINter:SEQUEnce:CONTrol <ptr seq ctrl>  
SOURce:DATA:TELEcom:POINter:SEQUEnce:CONTrol?

Parameters	<pointer seq control> (discrete)	Description
	START	Starts a pointer sequence
	STOP	Stops a pointer sequence

**Dependencies** POINter:MODE SEQUEnce or POINter:MODE TRIButary and TRIButary:POINter:MODE SEQUEnce must be selected.

**Errors and Events** 221, "Settings conflict; Not available without jitter option"

**Examples**  
Set: SOURCE:DATA:TELECOM:POINTER:SEQUENCE:CONTROL START  
Query: SOURCE:DATA:TELECOM:POINTER:SEQUENCE:CONTROL?  
Response: STOP

**Related Commands** SOURce:DATA:TELEcom:POINter:MODE  
SOURce:DATA:TELEcom:POINter:SEQUEnce:STATUS?

## SOURce:DATA:TELEcom:POINter:SEQuence:STATUs?

This query returns the pointer sequence status.

**Syntax** SOURce:DATA:TELEcom:POINter:SEQuence:STATUs?

Response	<pointer seq status> (discrete)	Description
	STOPPED	Not running sequences
	INITIALizing	Initialization period
	COOLdown	Cool down period
	OPERating	Running sequences

**Dependencies** None

**Errors and Events** None

**Examples** Query: SOURce:DATA:TELECOM:POINter:SEQuence:STATUs?  
 Response: INIT

**Related Commands** SOURce:DATA:TELEcom:POINter:MODE  
 SOURce:DATA:TELEcom:POINter:SEQuence:CONTrol?

**SOURce:DATA:TELEcom:POINter:SEQuence:ANOMaly:BTIME?**

This query returns the pointer sequence time between anomalies in seconds.

Sequences do not have to be running. This calculation is based upon sequence type and rate.

**Syntax** SOURce:DATA:TELEcom:POINter:SEQuence:ANOMaly:BTIME?

Response	<pointer seq btime> (NR1-numeric)	Description
	Any positive integer	Time between anomalies in seconds
	-1	Returned for sequences with an invalid BTIME. Example: continuous without anomalies

**Dependencies** None

**Errors and Events** None

**Examples**  
 Query: SOURCE:DATA:TELECOM:POINTER:SEQUENCE:ANOMALY:BTIME?  
 Response: 30

**Related Commands**  
 SOURce:DATA:TELEcom:POINter:MODE  
 SOURce:DATA:TELEcom:POINter:SEQuence:CONTRol  
 SOURce:DATA:TELEcom:POINter:SEQuence:TYPE  
 SOURce:DATA:TELEcom:POINter:SEQuence:RATE

## SOURce:DATA:TELEcom:POINter:SEQuence:ANOMaly:NTIME?

This query returns the pointer sequence time until the next anomaly in seconds.

This query is only meaningful if sequences are running (STATus? is "OPERATING").

**Syntax** SOURce:DATA:TELEcom:POINter:SEQuence:ANOMaly:NTIME?

Response	<pointer seq ntime> (NR1-numeric)	Description
	Any positive integer	Time until the next anomaly in seconds
	-1	Returned for sequences with an invalid NTIME (Example: continuous without anomalies) or if in the following states: STOPPED, INITIALizing, or COOLdown

**Dependencies** None

**Errors and Events** None

**Examples**  
 Query: SOURce:DATA:TELECOM:POINTER:SEQUENCE:ANOMALY:NTIME?  
 Response: 4

**Related Commands**  
 SOURce:DATA:TELEcom:POINter:MODE  
 SOURce:DATA:TELEcom:POINter:SEQuence:CONTRol  
 SOURce:DATA:TELEcom:POINter:SEQuence:TYPE  
 SOURce:DATA:TELEcom:POINter:SEQuence:RATE



## SOURce:DATA:TELEcom:TRIButary Subsystem

Add/Drop Test Option Only

This section describes the commands and queries that control the tributary signals. Figure 2–17 shows the hierarchy tree for this subsystem.

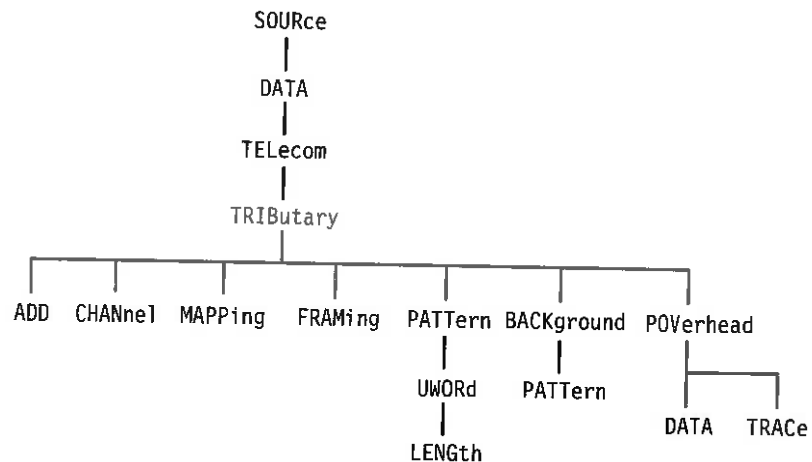

Figure 2–17: SOURce:DATA:TELEcom:TRIButary subsystem

## SOURce:DATA:TELEcom:TRIButary:ADD

Add/Drop Test Option Only

This command sets or queries the tributary payload data source.

**Syntax** SOURce:DATA:TELEcom:TRIButary:ADD <trib add>  
SOURce:DATA:TELEcom:TRIButary:ADD?

Parameters	<trib add> (boolean)	Description
	OFF or 0	Internal source; an internally generated data pattern is placed in the payload (default)
	ON or 1	External tributary signal mapped into the signal; signal mapping is determined by the SOURce:DATA:TELEcom:TRIButary: MAPPING command; if no signal is present, AIS is mapped into the payload

**Dependencies**     None

**Errors and Events**     None

**Examples**     Set:        SOURCE:DATA:TELECOM:TRIBUTARY:ADD ON  
                   Query:      SOURCE:DATA:TELECOM:TRIBUTARY:ADD?  
                   Response: 1

**Related Commands**     INPUT2 and INPUT3 subsystems

## SOURCE:DATA:TELECOM:TRIBUTARY:CHANNEL

Add/Drop Test Option Only

This command sets or queries the TUASYNC channel.

**Syntax**     SOURCE:DATA:TELECOM:TRIBUTARY:CHANNEL <trib channel>  
                   SOURCE:DATA:TELECOM:TRIBUTARY:CHANNEL?

Parameters	<trib channel> (NR1-numeric)	Description
	Any integer between 1 and 63	TUASYNC (TU-12) mapping (default = 1)
	Any integer between 1 and 3	TU-3 mapping (default = 1)
	1	M140 mapping

**Dependencies**     SOURCE:DATA:TELECOM:TRIBUTARY:MAPPING determines the number of channels available for selection.

**Errors and Events**     None

**Examples**     Set:        SOURCE:DATA:TELECOM:TRIBUTARY:CHANNEL 1  
                   Query:      SOURCE:DATA:TELECOM:TRIBUTARY:CHANNEL?  
                   Response: 3

**Related Commands**     SOURCE:DATA:TELECOM:TRIBUTARY:MAPPING

## SOURce:DATA:TELEcom:TRIButary:MAPPING

Add/Drop Test Option Only

This command sets or queries the tributary payload mapping. When you are actively mapping and demapping a tributary signal, the SOURce:DATA:TELEcom:TRIButary:MAPPING and SENSE:DATA:TELEcom:TRIButary:MAPPING functions are coupled; a change to one causes the same change to the other. When this command is sent, the C2 byte of the path overhead is set.

**Syntax** SOURce:DATA:TELEcom:TRIButary:MAPPING <trib mapping>  
SOURce:DATA:TELEcom:TRIButary:MAPPING?

Parameters	<trib mapping> (discrete)	Description
	TUASYNC	Mapped 2 Mb/s signal into TU-12 floating async (default)
	TU3	Mapped 34 Mb/s signal
	M140	Mapped 140 Mb/s signal

**Dependencies** None

**Errors and Events** None

**Examples**  
Set:       SOURCE:DATA:TELECOM:TRIBUTARY:MAPPING TUASYNC  
Query:     SOURCE:DATA:TELECOM:TRIBUTARY:MAPPING?  
Response:  TUASYNC

**Related Commands** SOURce:DATA:TELEcom:PAYLoad:CHANnel

## SOURCE:DATA:TELECOM:TRIBUTARY:FRAMING

Add/Drop Test Option Only

This command sets or queries the transmitted tributary signal framing.

**Syntax** SOURCE:DATA:TELECOM:TRIBUTARY:FRAMING <trib framing>  
SOURCE:DATA:TELECOM:TRIBUTARY:FRAMING?

Parameters	<trib framing> (discrete)	Description
	UNFRamed	No framing (default)
	PCM30	2 Mb/s, PCM, 30 channels, no CRC checking
	PCM31	2 Mb/s, PCM, 31 channels, no CRC checking
	PCM30CRC	2 Mb/s, PCM, 30 channels, with CRC checking
	PCM31CRC	2 Mb/s, PCM 31 channels, with CRC checking
	FRAMED	34 Mb/s or 140 Mb/s framing

**Dependencies** None

**Errors and Events** None

**Examples**  
Set: SOURCE:DATA:TELECOM:TRIBUTARY:FRAMING UNFRAMED  
Query: SOURCE:DATA:TELECOM:TRIBUTARY:FRAMING?  
Response: FRAMED

**Related Commands** None

**SOURce:DATA:TELEcom:TRIButary:PATtern**

Add/Drop Test Option Only

This command sets or queries the internally generated pattern that is placed in the tributary payload.

**Syntax** SOURce:DATA:TELEcom:TRIButary:PATtern <trib pattern>  
SOURce:DATA:TELEcom:TRIButary:PATtern?

Parameters	<trib pattern> (discrete)	Description
	PRBS23	A pseudo-random binary sequence of length $2^{23}-1$ is placed in the tributary payload (default)
	PRBS15	A pseudo-random binary sequence of length $2^{15}-1$ is placed in the tributary payload
	PRBS20	A pseudo-random binary sequence of length $2^{20}-1$ is placed in the tributary payload
	AZEROs	All zeros are placed in the payload
	AONEs	All ones are placed in the payload
	UWORD	A user-defined pattern is placed in the payload
	FIXED_1_8	1 bit in 8 set; #H80 (all PDH rates)

**Dependencies** SOURce:DATA:TELEcom:TRIButary:ADD must be set to OFF for this command to apply.

**Errors and Events** None

**Examples**  
Set: SOURCE:DATA:TELECOM:TRIBUTARY:PATTERN PRBS15  
Query: SOURCE:DATA:TELECOM:TRIBUTARY:PATTERN?  
Response: AONES

**Related Commands** SOURce:DATA:TELEcom:TRIButary:PATtern:UWORD

**SOURce:DATA:TELEcom:TRIButary:PATtern:UWORD**

Add/Drop Test Option Only

This command sets or queries the user-defined pattern that is placed in the tributary payload.

**Syntax** SOURce:DATA:TELEcom:TRIButary:PATtern:UWORD <trib user pat>  
SOURce:DATA:TELEcom:TRIButary:PATtern:UWORD?

Parameters	<trib user pat> (hexadecimal)	Description
	Any 8, 16, or 24 bit hexadecimal number in the range #H00 to #HFFFFFF	Repeating pattern is placed in the tributary payload (default = #H00)

**Dependencies** SOURce:DATA:TELEcom:TRIButary:PATtern must be set to UWORD for this command to apply. Use the SOURce:DATA:TELEcom:TRIButary:PATtern:UWORD:LENgth command to set the length of the repeating pattern.

**Errors and Events** None

**Examples**

Set:       SOURCE:DATA:TELECOM:TRIBUTARY:PATTERN:UWORD #HAA5500

Query:     SOURCE:DATA:TELECOM:TRIBUTARY:PATTERN:UWORD?

Response:  #HAA5500

**Related Commands** SOURce:DATA:TELEcom:TRIButary:PATtern  
SOURce:DATA:TELEcom:TRIButary:PATtern:UWORD:LENgth

**SOURce:DATA:TELEcom:TRIButary:PATtern:UWORD:LENGTH**

Add/Drop Test Option Only

This command sets or queries the number of bytes of the user-defined pattern that are repeated in the tributary payload.

**Syntax** SOURce:DATA:TELEcom:TRIButary:PATtern:UWORD:LENGTH <patrn len>  
SOURce:DATA:TELEcom:TRIButary:PATtern:UWORD:LENGTH?

Parameters	<patrn len> (NR1-numeric)	Description
	Any integer in the range 1 to 3	Number of bytes of user-defined pattern that are repeated in the tributary payload (default = 1)

**Dependencies** SOURce:DATA:TELEcom:TRIButary:PATtern must be set to UWORD for this command to apply. Use the SOURce:DATA:TELEcom:TRIButary:PATtern:UWORD command to set the repeating pattern.

**Errors and Events** None

**Examples**  
Set:       SOURCE:DATA:TELECOM:TRIBUTARY:PATTERN:UWORD:LENGTH 3  
Query:     SOURCE:DATA:TELECOM:TRIBUTARY:PATTERN:UWORD:LENGTH?  
Response:  2

**Related Commands** SOURce:DATA:TELEcom:TRIButary:PATtern:UWORD

## SOURce:DATA:TELEcom:TRIButary:BACKground:PATtern

Add/Drop Test Option Only

This command sets or queries the internally generated pattern that is placed in the tributary payload for inactive channels.

### Syntax

SOURce:DATA:TELEcom:TRIButary:BACKground:PATtern <trib bkgnd pat>  
SOURce:DATA:TELEcom:TRIButary:BACKground:PATtern?

### Parameters

<trib background pattern> (discrete)	Description
PRBS	A pseudo-random binary sequence of length $2^{15}-1$ is placed in the tributary payload of inactive channels (TUASYNC only) (default)
IDLE	An idle pattern is placed in the tributary payload of inactive channels

**Dependencies** None

**Errors and Events** None

**Examples**

Set: SOURCE:DATA:TELECOM:TRIBUTARY:BACKGROUND:PATTERN IDLE

Query: SOURCE:DATA:TELECOM:TRIBUTARY:BACKGROUND:PATTERN?

Response: IDLE

**Related Commands** None



## SOURce:DATA:TELEcom:TRIButary:POVerhead:DATA

This command sets or queries the bytes in the tributary path overhead.

**Syntax** SOURce:DATA:TELEcom:TRIButary:POVerhead:DATA <byte name>,<value>  
SOURce:DATA:TELEcom:TRIButary:POVerhead:DATA? <byte>

Parameters	<byte name> (discrete)	Description
	C2	Signal label (TU3)
	F2	User channel (TU3)
	H4	Indicator (TU3)
	F3	Growth bytes (TU3)
	K3	(TU3)
	K4	(TU12)
	N1	(TU3)
	N2	(TU12)
	V5	(TU12)
	<value> (NR1-numeric) <sup>3</sup>	Description
	Any integer in the range 0 to 255 (hexadecimal 00 to FF)	The selected byte is set to this value

<sup>3</sup> A hexadecimal value is also acceptable.

**Dependencies** None

**Errors and Events** None

**Examples**  
 Set: SOURCE:DATA:TELECOM:TRIBUTARY:POVERHEAD:DATA V5,#H55  
 Query: SOURCE:DATA:TELECOM:TRIBUTARY:POVERHEAD:DATA? V5  
 Response: 245

**Related Commands** SOURce:DATA:TELEcom:TRIButary:POVerhead:TRACe

## SOURce:DATA:TELEcom:TRIButary:POVerhead:TRACe?

This query returns the current path trace string that repeats in the J1 byte, for TU3, and the J2 byte for TU12 mapping, as a 16 character repeating sequence.

**Syntax** SOURce:DATA:TELEcom:TRIButary:POVerhead:TRACe?

**Response**

<path trace> (string)	Description
A 16 character string	The J1 or J2 path trace string

**Dependencies** None

**Errors and Events** None

**Examples**  
 Query: SOURCE:DATA:TELECOM:TRIBUTARY:POVERHEAD:TRACE?  
 Response: "TEK CTS750"

**Related Commands** SOURce:DATA:TELEcom:POVerhead:TRACe

## SOURce:DATA:TELEcom:TRIButary:ERRor, ALARm, FAILure Subsystem

This section describes subsystem commands that control abnormal conditions in the transmitted tributary signal. Figure 2–18 shows the hierarchy tree for this subsystem.

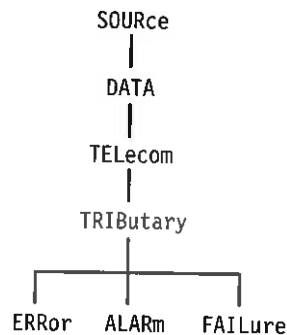

Figure 2–18: SOURce:DATA:TELEcom:TRIButary:ERRor, ALARm, FAILure subsystem

## SOURce:DATA:TELEcom:TRIButary:ERRor

Add/Drop Test Option Only

This command sets or queries the type of tributary error that is transmitted at a rate specified by SOURce:DATA:TELEcom:ERRor:RATE. Use the SOURce:DATA:TELEcom:ERRor:IMMediate command to insert the error.

**Syntax** SOURce:DATA:TELEcom:TRIButary:ERRor <trib error>  
SOURce:DATA:TELEcom:TRIButary:ERRor?

Parameters	<trib error> (discrete)	Description
	NONE	No error transmitted
	DATA	Error in pattern
	FRAMe	Frame error
	CRC	CRC error; you must be transmitting a 2 Mb/s tributary signal (PCM30CRC and PCM31CRC framing only)
	TUFEbe	TU FEBE
	TUBIP	TU BIP

**Dependencies** SOURCE:DATA:TELEcom:ERRor:TYPE must be set to TRIButary for this query to apply.

**Errors and Events** None

**Examples**  
 Set: SOURCE:DATA:TELECOM:ERROR DATA  
 Query: SOURCE:DATA:TELECOM:ERROR?  
 Response: CRC

**Related Commands** SOURCE:DATA:TELEcom:ERRor:TYPE  
 SOURCE:DATA:TELEcom:ERRor:RATE  
 SOURCE:DATA:TELEcom:ERRor:IMMediate

## SOURCE:DATA:TELEcom:TRIButary:ALARm

Add/Drop Test Option Only

This command sets or queries a tributary alarm to transmit.

**Syntax** SOURCE:DATA:TELEcom:TRIButary:ALARm <trib alarm>  
 SOURCE:DATA:TELEcom:TRIButary:ALARm?

**Parameters**

<trib alarm> (discrete)	Description
NONE	No alarm transmitted (default)
AIS	Tributary AIS
TUFERf	TU FERF
TUAis	TU AIS
RAI	Remote Alarm Indication

**Dependencies** None

**Errors and Events** None

**Examples** Set: SOURCE:DATA:TELECOM:TRIBUTARY:ALARM NONE  
 Query: SOURCE:DATA:TELECOM:TRIBUTARY:ALARM?  
 Response: RAI

**Related Commands** None

## SOURCE:DATA:TELECOM:TRIBUTARY:FAILURE

Add/Drop Test Option Only

This command sets or queries a tributary failure to transmit.

**Syntax** SOURCE:DATA:TELECOM:TRIBUTARY:FAILURE <trib failure>  
 SOURCE:DATA:TELECOM:TRIBUTARY:FAILURE?

Parameters	<trib failure> (discrete)	Description
	NONE	No failure transmitted (default)
	TULOP	TU Loss of Pointer
	TULOM	TU Loss of Multiframe

**Dependencies** None

**Errors and Events** None

**Examples** Set: SOURCE:DATA:TELECOM:TRIBUTARY:FAILURE NONE  
 Query: SOURCE:DATA:TELECOM:TRIBUTARY:FAILURE?  
 Response: TULOP

**Related Commands** None

## SOURce:DATA:TELEcom:TRIButary:POINter Subsystem

### Add/Drop Test Option Only

This section describes the commands and queries that adjust pointers for the transmitted TU mapped signal. Figure 2–19 shows the hierarchy tree for this subsystem.

---

**NOTE.** *SOURce:DATA:TELEcom:POINter:MODE* must be set to *TRIButary* for any command or query in this section to apply.

---

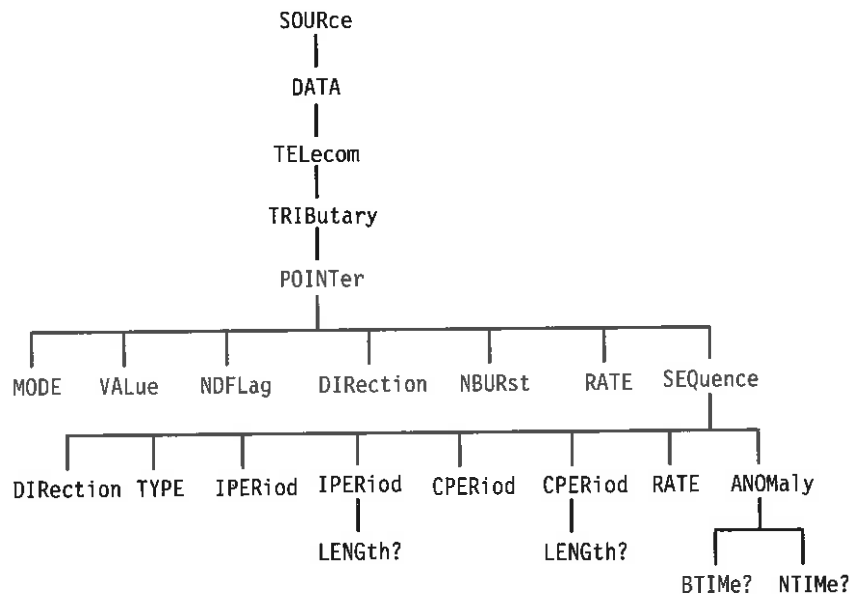

Figure 2–19: SOURce:DATA:TELEcom:TRIButary:POINter subsystem

**SOURce:DATA:TELEcom:TRIButary:POINter:MODE**

Add/Drop Test Option Only

This command sets or queries the TU pointer manipulation modes.

**Syntax** SOURce:DATA:TELEcom:TRIButary:POINter:MODE <trib ptr mode>  
 SOURce:DATA:TELEcom:TRIButary:POINter:MODE?

Parameters	<trib ptr mode> (discrete)	Description
	MANual	Pointers are controlled by SOURce:DATA:TRIButary:POINter:VALue and SOURce:DATA:TRIButary:POINter:NDFLag (default)
	SINGLE	Pointer adjustments are controlled by the SOURce:DATA:TELEcom:POINter:ACTIon and SOURce:DATA:TELEcom:POINter:DIRectIon commands
	BURSt	When the SOURce:DATA:TELEcom:POINter:ACTIon command is given, a burst of pointer adjustments is sent at the maximum rate (1 in 4 frames) with a count defined by SOURce:DATA:TRIButary:POINter:NBURst
	FOFFset	Tributary pointers are controlled by the SOURce:CLOCK:OFFSet subsystem.
	CONTInuous	Pointers are continuously adjusted according to the SOURce:DATA:TRIButary:POINter:DIRectIon and SOURce:DATA:TRIButary:POINter:RATE commands
	SEQUence	Pointers are stressed according to sequences defined in T1.105.03-1994 or G.783

**Dependencies** SOURce:DATA:TELEcom:POINter:MODE must be set to TRIButary for this command to apply. You can control only AU or TU pointer adjustments at any one time.

**Errors and Events** None

**Examples** Set: SOURCE:DATA:TELECOM:TRIBUTARY:POINTER:MODE MANUAL  
 Query: SOURCE:DATA:TELECOM:TRIBUTARY:POINTER:MODE?  
 Response: BURSt

**Related Commands** SOURce:DATA:TELEcom:POINter:MODE

## SOURce:DATA:TELEcom:TRIButary:POINter:VALue

Add/Drop Test Option Only

This command sets or queries the TU pointer value. If SOURce:DATA:TELEcom:TRIButary:POINter:NDFLag is set to ON, a New Data Flag (NDF) is sent with each new value received.

**Syntax** SOURce:DATA:TELEcom:TRIButary:POINter:VALue <trib ptr value>  
 SOURce:DATA:TELEcom:TRIButary:POINter:VALue?

Parameters	<trib ptr value> (NR1-numeric)	Description
	Any integer in the range 0 to 1023	TUASYNC (default = 105, illegal > 139) TU3 (default = 595, illegal > 764)

**Dependencies** SOURce:DATA:TELEcom:POINter:MODE must be set to TRIButary for this command to apply. You can control only AU or TU pointer adjustments at any one time.

SOURce:DATA:TELEcom:TRIButary:POINter:MODE must be set to MANual for this command to apply.

**Errors and Events** None

**Examples** Set: SOURCE:DATA:TELECOM:TRIBUTARY:POINTER:VALUE 10  
 Query: SOURCE:DATA:TELECOM:TRIBUTARY:POINTER:VALUE?  
 Response: 26

**Related Commands** SOURce:DATA:TELEcom:TRIButary:POINter:MODE



**SOURce:DATA:TELEcom:TRIButary:POINter:NDFLag**

Add/Drop Test Option Only

This command sets or queries the generation of a New Data Flag (NDF) when TU pointer adjustments occur.

**Syntax** SOURce:DATA:TELEcom:TRIButary:POINter:NDFLag <trib NDF state>  
SOURce:DATA:TELEcom:TRIButary:POINter:NDFLag?

Parameters	<trib NDF state> (boolean)	Description
	1 or ON	On (default)
	0 or OFF	Off

**Dependencies** SOURce:DATA:TELEcom:POINter:MODE must be set to TRIButary for this command to apply. You can control only AU or TU pointer adjustments at any one time.

SOURce:DATA:TELEcom:TRIButary:POINter must be set to MANual for this command to apply.

**Errors and Events** None

**Examples**

Set:       SOURCE:DATA:TELECOM:TRIBUTARY:POINTER:NDFLAG ON

Query:     SOURCE:DATA:TELECOM:TRIBUTARY:POINTER:NDFLAG?

Response:  0

**Related Commands** SOURce:DATA:TELEcom:TRIButary:POINter:VALue  
SOURce:DATA:TELEcom:TRIButary:POINter:MODE

## SOURce:DATA:TELEcom:TRIButary:POINter:DIRection

Add/Drop Test Option Only

This command sets or queries the direction of continuous TU pointer adjustments.

**Syntax** SOURce:DATA:TELEcom:TRIButary:POINter:DIRection <trib ptr dir>  
SOURce:DATA:TELEcom:TRIButary:POINter:DIRection?

Parameters	<trib ptr dir> (discrete)	Description
	ALternate	Pointer adjustments alternate between up and down (default)
	DOWN	Pointers adjusted down
	UP	Pointers adjusted up

**Dependencies** SOURce:DATA:TELEcom:POINter:MODE must be set to TRIButary for this command to apply. You can control only AU or TU pointer adjustments at any one time.

SOURce:DATA:TELEcom:TRIButary:POINter:MODE must be set to CONTInuous for this command to apply.

**Errors and Events** None

**Examples**  
Set: SOURCE:DATA:TELECOM:TRIBUTARY:POINTER:DIRECTION UP  
Query: SOURCE:DATA:TELECOM:TRIBUTARY:POINTER:DIRECTION?  
Response: UP

**Related Commands** SOURce:DATA:TELEcom:TRIButary:POINter:MODE  
SOURce:DATA:TELEcom:TRIButary:POINter:RATE

**SOURce:DATA:TELEcom:TRIButary:POINter:NBURst**

Add/Drop Test Option Only

This command sets or queries the number of pointer adjustments in a burst of TU pointer adjustments. Send the SOURce:DATA:TELEcom:POINter:ACTion command to create the burst of pointer adjustments.

**Syntax** SOURce:DATA:TELEcom:TRIButary:POINter:NBURst <trib ptr burst>  
SOURce:DATA:TELEcom:TRIButary:POINter:NBURst?

Parameters	<trib ptr burst> (NR1-numeric)	Description
	Any integer in the range 2 to 8	This value determines the number of pointer adjustments in a burst of pointer adjustments (default = 2)

**Dependencies** SOURce:DATA:TELEcom:POINter:MODE must be set to TRIButary for this command to apply. You can control only AU or TU pointer adjustments at any one time.

SOURce:DATA:TELEcom:TRIButary:POINter:MODE must be set to BURSt for this command to apply.

**Errors and Events** None

**Examples**  
Set:       SOURCE:DATA:TELECOM:TRIBUTARY:POINTER:NBURST 2  
Query:     SOURCE:DATA:TELECOM:TRIBUTARY:POINTER:NBURST?  
Response:  6

**Related Commands** SOURce:DATA:TELEcom:TRIButary:POINter:MODE  
SOURce:DATA:TELEcom:POINter:ACTion  
SOURce:DATA:TELEcom:POINter:MODE

## SOURce:DATA:TELEcom:TRIButary:POINter:RATE

Add/Drop Test Option Only

This command sets or queries the continuous TU pointer adjustment rate.

**Syntax** SOURce:DATA:TELEcom:TRIButary:POINter:RATE <trib ptr rate>  
 SOURce:DATA:TELEcom:TRIButary:POINter:RATE?

Parameters	<trib ptr rate> (NR1-numeric)	Description
	An integer in the range 2 to 10,000	The pointer adjustment rate, in milliseconds

**Dependencies** SOURce:DATA:TELEcom:POINter:MODE must be set to TRIButary for this command to apply. You can control only AU or TU pointer adjustments at any one time.

SOURce:DATA:TELEcom:TRIButary:POINter:MODE must be set to CONTInuous for this command to apply.

**Errors and Events** None

**Examples**  
 Set:       SOURCE:DATA:TELECOM:TRIBUTARY:POINTER:RATE 9  
 Query:     SOURCE:DATA:TELECOM:TRIBUTARY:POINTER:RATE?  
 Response:  10

**Related Commands** SOURce:DATA:TELEcom:TRIButary:POINter:DIRection  
 SOURce:DATA:TELEcom:TRIButary:POINter:MODE  
 SOURce:DATA:TELEcom:POINter:MODE

**SOURce:DATA:TELEcom:TRIButary:POINter:SEQuence:DIRectioN**

Add/Drop Test Option Only

This command sets or queries the pointer movement direction.

Setting this parameter when a sequence is running returns an error.

**Syntax** SOURce:DATA:TELEcom:TRIButary:POINter:SEQuence:DIRectioN  
 <ptr seq direction>  
 SOURce:DATA:TELEcom:TRIButary:POINter:SEQuence:DIRectioN?

Parameters	<ptr seq direction> (discrete)	Description
	DOWN	
	UP	(default)

**Dependencies** Pointer sequences must not be running.

**Errors and Events** 221, "Settings conflict"

**Examples**

Set:       SOURce:DATA:TELECOM:TRIBUTARY:POINTER:SEQUENCE  
              :DIRECTION UP

Query:     SOURce:DATA:TELECOM:TRIBUTARY:POINTER:SEQUENCE  
              :DIRECTION?

Response: UP

**Related Commands** SOURce:DATA:TELEcom:POINter:MODE  
 SOURce:DATA:TELEcom:POINter:SEQuence:CONTRol

**SOURce:DATA:TELEcom:TRIButary:POINter:SEQuence:RATE**

Add/Drop Test Option Only

This command sets or queries the pointer sequence movement rate in milliseconds.

Setting this parameter when a sequence is running returns an error.

**Syntax** SOURce:DATA:TELEcom:TRIButary:POINter:SEQuence:RATE  
 <ptr seq rate>  
 SOURce:DATA:TELEcom:TRIButary:POINter:SEQuence:RATE?

Parameters	<ptr seq rate> (NR1-numeric)	Description
	Any integer from 34 to 30,000 ms	Resolution is 1 ms (default depends on mapping and type)

**Dependencies** Pointer sequences must not be running.

Some sequence types (like single, burst, phase, sinalt, and dblalt) set the rate to 30,000 ms. With these types, you cannot change the rate.

**Errors and Events** 221, "Settings conflict; stop sequences before setting the rate"

**Examples**

Set:       SOURce:DATA:TELECOM:TRIBUTARY:POINTER:SEQUENCE  
               :RATE 2000

Query:     SOURce:DATA:TELECOM:TRIBUTARY:POINTER:SEQUENCE  
               :RATE?

Response:  10000

**Related Commands** SOURce:DATA:TELEcom:POINter:MODE  
 SOURce:DATA:TELEcom:POINter:SEQuence:CONTRol  
 SOURce:DATA:TELEcom:POINter:SEQuence:TYPE

## SOURce:DATA:TELEcom:TRIButary:POINter:SEQuence:TYPE

Add/Drop Test Option Only

This command sets or queries the pointer sequence type.

Setting this parameter when a sequence is running returns an error.

**Syntax** SOURce:DATA:TELEcom:TRIButary:POINter:SEQuence:TYPE  
<ptr seq type>  
SOURce:DATA:TELEcom:TRIButary:POINter:SEQuence:TYPE?

### Parameters

<ptr seq type> (discrete)	Description
SINGLE	Single pointer adjustment (G.783 e)
BURSt	Burst pointer adjustment (G.783 f)
PHASe	Phase transient pointer adjustment
P351	Periodic 35-1 pointer adjustment (TU-12 only)
P351CAN	Periodic 35-1 with cancel (TU-12 only)
P351ADD	Periodic 35-1 with add (TU-12 only)
P855	Periodic 85-5 pointer adjustment (TU-3 only)
P855CAN	Periodic 85-5 with cancel (TU-3 only)
P855ADD	Periodic 85-5 with add (TU-3 only)
PCONtinuous	Periodic continuous pointer adjustment (G.783 h1)
PCONCAN	Periodic continuous with cancel (G.783 h3)
PCONADD	Periodic continuous with add (G.783 h2)
REGDBL	Regular pointer plus one double (G.783 b)
REGMIS	Regular pointer with one missing (G.783 c)
SINALT	Single alternating pointer (G.783 a) (default)
DBLALT	Double alternating pointer (G.783 d)

**Dependencies** Pointer sequences must not be running.

G.783 only applies to TU mappings.

**Errors and Events** 221, "Settings conflict; stop sequences before setting type"

<b>Examples</b>	Set: SOURCE:DATA:TELECOM:TRIBUTARY:POINTER:SEQUENCE:TYPE BURST  Query: SOURCE:DATA:TELECOM:TRIBUTARY:POINTER:SEQUENCE:TYPE?  Response: PHASe
<b>Related Commands</b>	SOURce:DATA:TELEcom:POINter:MODE SOURce:DATA:TELEcom:POINter:SEQuence:CONTRol
<b>Errors and Events</b>	None

## SOURce:DATA:TELEcom:TRIButary:POINter:SEQuence:IPERiod

Add/Drop Test Option Only

This command sets or queries the pointer sequence initialization period.

Setting this parameter when a sequence is running returns an error.

**Syntax** SOURce:DATA:TELEcom:TRIButary:POINter:SEQuence:IPERiod  
<ptr seq init>  
SOURce:DATA:TELEcom:TRIButary:POINter:SEQuence:IPERiod?

Parameters	<ptr seq init> (discrete)	Description
	0 (or OFF)	Disables the pointer sequence initialization period
	1 (or ON)	Enables the pointer sequence initialization period (default)

**Dependencies** Pointer sequences must not be running.

**Errors and Events** 221, "Settings conflict; stop sequences before setting the period"



**Examples** Set: SOURCE:DATA:TELECOM:TRIBUTARY:POINTER:SEQUENCE:IPERIOD ON  
 Query: SOURCE:DATA:TELECOM:TRIBUTARY:POINTER:SEQUENCE:IPERIOD?  
 Response: 1

**Related Commands** SOURce:DATA:TELEcom:POINter:MODE  
 SOURce:DATA:TELEcom:POINter:SEQuence:CONTRol

## SOURce:DATA:TELEcom:TRIButary:POINter:SEQuence:IPERiod:LENGth?

Add/Drop Test Option Only

This query returns the pointer sequence initialization period in seconds.

**Syntax** SOURce:DATA:TELEcom:TRIButary:POINter:SEQuence:IPERiod:LENGth?

**Response**

<pointer seq init> (NR1-numeric)	Description
Any integer	Pointer sequence initialization period in seconds

**Dependencies** None

**Errors and Events** None

**Examples** Query: SOURCE:DATA:TELECOM:TRIBUTARY:POINTER:SEQUENCE:IPERIOD:LENGTH  
 Response: 30

**Related Commands** SOURce:DATA:TELEcom:TRIButary:POINter:SEQuence:IPERiod  
 SOURce:DATA:TELEcom:TRIButary:POINter:SEQuence:RATE  
 SOURce:DATA:TELEcom:TRIButary:POINter:SEQuence:TYPE

## SOURce:DATA:TELEcom:TRIButary:POINter:SEQuence:CPERiod

Add/Drop Test Option Only

This command sets or queries the pointer sequence cool down period.

Setting this parameter when a sequence is running returns an error.

**Syntax** SOURce:DATA:TELEcom:TRIButary:POINter:SEQuence:CPERiod  
 <ptr seq init>  
 SOURce:DATA:TELEcom:TRIButary:POINter:SEQuence:CPERiod?

Parameters	<ptr seq init> (discrete)	Description
	0 (or OFF)	Disables the pointer sequence cool down period
	1 (or ON)	Enables the pointer sequence cool down period (default)

**Dependencies** Pointer sequences must not be running.

**Errors and Events** 221, "Settings conflict; stop sequences before setting the period"

**Examples**

Set:       SOURCE:DATA:TELECOM:TRIBUTARY:POINTER:SEQUENCE  
               :CPERIOD OFF

Query:     SOURCE:DATA:TELECOM:TRIBUTARY:POINTER:SEQUENCE:CPERIOD?

Response:  1

**Related Commands** SOURce:DATA:TELEcom:POINter:MODE  
 SOURce:DATA:TELEcom:POINter:SEQuence:CONTRol

**SOURce:DATA:TELEcom:TRIButary:POINter:SEQuence:CPERiod:LENGth?**

Add/Drop Test Option Only

This query returns the pointer sequence cool down period in seconds.

**Syntax** SOURce:DATA:TELEcom:TRIButary:POINter:SEQuence:CPERiod:LENGth?

Response	<pointer seq init> (NR1-numeric)	Description
	Any integer: for TU12 mapping — from 360 to 60 for TU3 mapping — from 900 to 60	Pointer sequence cool down period in seconds

**Dependencies** None**Errors and Events** None**Examples**  
Query: SOURCE:DATA:TELECOM:TRIBUTARY:POINTER:SEQUENCE:  
CPERIOD:LENGTH

Response: 320

**Related Commands**  
SOURce:DATA:TELEcom:TRIButary:POINter:SEQuence:CPERiod  
SOURce:DATA:TELEcom:TRIButary:POINter:SEQuence:RATE  
SOURce:DATA:TELEcom:TRIButary:POINter:SEQuence:TYPE

**SOURce:DATA:TELEcom:TRIButary:POINter:SEQuence:ANOMaly:BTIME?**

This query returns the pointer sequence time between anomalies in seconds.

Sequences do not have to be running. This calculation is based upon sequence type and rate.

**Syntax** SOURce:DATA:TELEcom:TRIButary:POINter:SEQuence:ANOMaly:BTIME?

<b>Response</b>	<pointer seq btime> (NR1-numeric)	Description
	Any positive integer	Time between anomalies in seconds
	-1	Returned for sequences with an invalid BTIME. Example: continuous without anomalies

**Dependencies** None

**Errors and Events** None

**Examples** Query: SOURce:DATA:TELECOM:TRIButary:POINter:SEQuence:ANOMaly:BTIME?

Response: 30

**Related Commands** SOURce:DATA:TELEcom:POINter:MODE  
 SOURce:DATA:TELEcom:POINter:SEQuence:CONTRol  
 SOURce:DATA:TELEcom:TRIButary:POINter:SEQuence:TYPE  
 SOURce:DATA:TELEcom:TRIButary:POINter:SEQuence:RATE

**SOURce:DATA:TELEcom:TRIButary:POINter:SEQuence:ANOMaly:NTIME?**

This query returns the pointer sequence time until the next anomaly in seconds.

This query is only meaningful if sequences are running.

**Syntax** SOURce:DATA:TELEcom:TRIButary:POINter:SEQuence:ANOMaly:NTIME?

Response	<pointer seq ntime> (NR1-numeric)	Description
	Any positive integer	Time until the next anomaly in seconds
	-1	Returned for sequences with an invalid NTIME (Example: continuous without anomalies) or if in the following states: STOPPED, INITIALizing, or COOLdown

**Dependencies** None

**Errors and Events** None

**Examples** Query: SOURce:DATA:TELECOM:TRIButary:POINter:SEQuence:ANOMaly:NTIME?

Response: 4

**Related Commands** SOURce:DATA:TELEcom:POINter:MODE  
 SOURce:DATA:TELEcom:POINter:SEQuence:CONTRol  
 SOURce:DATA:TELEcom:TRIButary:POINter:SEQuence:TYPE  
 SOURce:DATA:TELEcom:TRIButary:POINter:SEQuence:RATE

## SOURce:DATA:TELEcom:JITter Subsystem

This section describes the commands and queries that control the jitter and wander settings. Figure 2–20 shows the hierarchy tree for this subsystem.

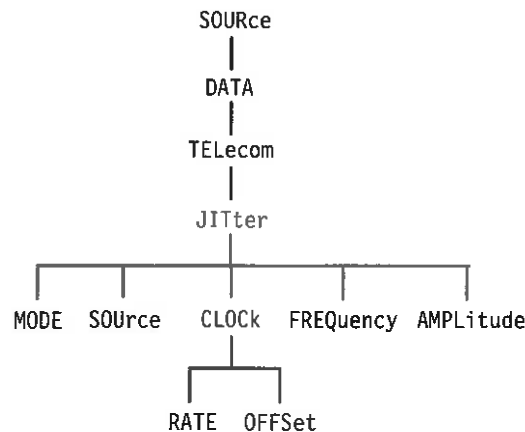

Figure 2–20: SOURce:DATA:TELEcom:JITter subsystem

## SOURce:DATA:TELEcom:JITter:MODE

SDH/PDH Jitter/Wander Test Option Only

This command sets or queries the jitter/wander generation mode.

**Syntax** SOURce:DATA:TELEcom:JITter:MODE <jitter mode>  
 SOURce:DATA:TELEcom:JITter:MODE?

Parameters	<jitter mode> (discrete)	Description
	OFF	No jitter or wander generation (default)
	ON	Turn jitter/wander generation ON

**Dependencies** Requires installation of Option 14 jitter module.

\*RST sets jitter mode to OFF (default).

**Errors and Events** 221, “Settings conflict; Not available without jitter option” if the jitter/wander test option is not installed and ON is selected.

**Examples** Set: SOURCE:DATA:TELECOM:JITTER:MODE ON  
 Query: SOURCE:DATA:TELECOM:JITTER:MODE?  
 Response: ON

**Related Commands** None

## SOURCE:DATA:TELECOM:JITTER:SOURCE

SDH/PDH Jitter/Wander Test Option Only

This command sets or queries the jitter or wander generation output destination.

**Syntax** SOURCE:DATA:TELECOM:JITTER:SOURCE <jitter output>  
 SOURCE:DATA:TELECOM:JITTER:SOURCE?

### Parameters

<jitter output> (discrete)	Description
LINE	Jitter the line (default)
CLOCK	Jitter the clock (0.8V)
G703	Jitter the clock (2 MHz G703; requires add/drop/test module)

**Dependencies** Requires installation of Option 14 jitter module.  
 \*RST sets jitter mode to LINE (default).

**Errors and Events** None

**Examples** Set: SOURCE:DATA:TELECOM:JITTER:SOURCE LINE  
 Query: SOURCE:DATA:TELECOM:JITTER:SOURCE?  
 Response: LINE

**Related Commands** SOURCE:DATA:TELECOM:JITTER:MODE

## SOURce:DATA:TELEcom:JITter:CLOCK:RATE

SDH/PDH Jitter/Wander Test Option Only

This command sets or queries the jitter or wander transmit clock rate.

**Syntax** SOURce:DATA:TELEcom:JITter:CLOCK:RATE <clock rate>  
 SOURce:DATA:TELEcom:JITter:CLOCK:RATE?

Parameters	<clock rate> (discrete)	Description
	M52	52 Mb/s rate
	M155	155 Mb/s rate
	M622	622 Mb/s rate
	M2	2 Mb/s rate (default)
	M34	34 Mb/s rate
	M140	140 Mb/s rate

**Dependencies** Requires installation of Option 14 jitter module.  
 \*RST sets the clock rate to M2 (default).

**Errors and Events** None

**Examples** Set: SOURCE:DATA:TELECOM:JITTER:CLOCK:RATE M140  
 Query: SOURCE:DATA:TELECOM:JITTER:CLOCK:RATE?  
 Response: M2

**Related Commands** SOURce:DATA:TELEcom:JITter:MODE  
 SOURce:DATA:TELEcom:JITter:SOURce



**SOURce:DATA:TELEcom:JITter:CLOCK:OFFSet**

SDH/PDH Jitter/Wander Test Option Only

This command sets or queries the output jitter clock frequency offset.

**Syntax**      SOURce:DATA:TELEcom:JITter:CLOCK:OFFSet <clock offset>  
 SOURce:DATA:TELEcom:JITter:CLOCK:OFFSet?

Parameters	<clock offset> (NR3-numeric)	Description
	-100.0 to 100.0	Frequency offset value in ppm (default is 0). Accuracy to 1 place after the decimal point.

**Dependencies**      Requires installation of Option 14 jitter module.

\*RST sets clock offset to 0 (default).

**Errors and Events**      500, "Execution warning"  
 if the entered value is out of range for the command.

**Examples**      Set:            SOURCE:DATA:TELECOM:JITTER:CLOCK:OFFSET 34

Query:          SOURCE:DATA:TELECOM:JITTER:CLOCK:OFFSET?

Response: 20.0

**Related Commands**      SOURce:DATA:TELEcom:JITter:MODE  
 SOURce:DATA:TELEcom:JITter:SOURce

## SOURce:DATA:TELEcom:JITter:FREQuency

SDH/PDH Jitter/Wander Test Option Only

This command sets the output jitter frequency.

**Syntax**    SOURce:DATA:TELEcom:JITter:FREQuency <jitter frequency>  
 SOURce:DATA:TELEcom:JITter:FREQuency?

Parameters	<jitter frequency> (NR3-numeric)	Description
	12 $\mu$ Hz to 400 KHz	Output jitter frequency range at 155 Mb
	12 $\mu$ Hz to 5 MHz	Output jitter frequency range at 622 Mb
	12 $\mu$ Hz to 100 kHz	Output jitter frequency range at 2 Mb
	12 $\mu$ Hz to 800 kHz	Output jitter frequency range at 34 Mb
	12 $\mu$ Hz to 3.5 MHz	Output jitter frequency range at 140 Mb

**Dependencies**    Requires installation of Option 14 jitter module.  
 \*RST sets the jitter frequency to 10 Hz (default).

**Errors and Events**    500, "Execution warning"  
 if the entered value is out range for the command.

**Examples**    Set:        SOURCE:DATA:TELECOM:JITTER:FREQUENCY 1000.0  
 Query:     SOURCE:DATA:TELECOM:JITTER:FREQUENCY?  
 Response:  250.0

**Related Commands**    SOURce:DATA:TELEcom:JITter:MODE  
 SOURce:DATA:TELEcom:JITter:AMPLitude

## SOURce:DATA:TELEcom:JITter:AMPLitude

SDH/PDH Jitter/Wander Test Option Only

This command sets or queries the output jitter amplitude range.

**Syntax** SOURce:DATA:TELEcom:JITter:AMPLitude <jitter ampl>  
 SOURce:DATA:TELEcom:JITter:AMPLitude?

### Parameters

Rate	Amplitude scale in UI <sub>p-p</sub>			
	A <sub>0</sub>	A <sub>1</sub>	A <sub>2</sub>	A <sub>3</sub>
52 Mb/s rate	100 k	10	3	1
155 Mb/s rate	100 k	10	3	1
622 Mb/s rate	100 k	10	3	1

Rate	Frequency scale in Hz					
	f <sub>0</sub>	f <sub>1</sub>	f <sub>2</sub>	f <sub>3</sub>	f <sub>4</sub>	f <sub>5</sub>
52 Mb/s rate	12 μ	30	300	10 k	130 k	400 k
155 Mb/s rate	12 μ	30	300	35 k	430 k	1.3 M
622 Mb/s rate	12 μ	30	300	125 k	1.7 M	5 M

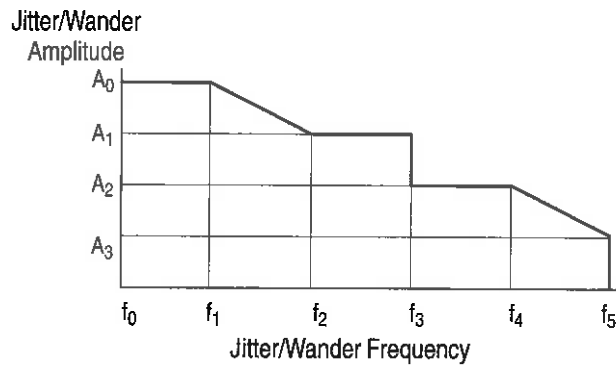

Figure 2-21: Jitter/Wander amplitude and frequency limits

**Dependencies** Ranges at each rate depend on current jitter frequency. Refer to the parameters table and Figure 2–21 to determine amplitude ranges for each frequency range  
\*RST sets jitter amplitude to 1.00 UI (default value).

**Errors and Events** 500, “Execution warning”  
if the entered value is out range for the command.

**Examples** Set: SOURCE:DATA:TELECOM:JITTER:AMPLITUDE 1.6  
Query: SOURCE:DATA:TELECOM:JITTER:AMPLITUDE?  
Response: 16.4

**Related Commands** SOURce:DATA:TELEcom:JITter:MODE  
SOURce:DATA:TELEcom:JITter:FREQuency

# Receive Commands

The Receive Commands allow you to set up the physical connections of a received signal and measure the signal. This section contains all of the commands and queries for each of the following Receive subsystems:

- INPUT1
- INPUT2 (Add/Drop Test Option Only)
- INPUT3 (Add/Drop Test Option Only)
- SENSE:DATA:TELEcom
- SENSE:DATA:TELEcom:TEST
- SENSE:DATA:TELEcom:TEST:JITter
- SENSE:DATA:TELEcom:OVERhead and POverhead
- SENSE:DATA:TELEcom:MEASure
- SENSE:DATA:TELEcom:MEASure:STESts
- SENSE:DATA:TELEcom:MEASure:JITter (SDH/PDH Jitter/Wander Test Option Only)
- SENSE:DATA:TELEcom:MEASure:WANDer
- SENSE:DATA:TELEcom:MEASure:TRIButary (Add/Drop Test Option Only)
- SENSE:DATA:TELEcom:AUTOscan
- SENSE:DATA:TELEcom:TRIButary (Add/Drop Test Option Only)
- SENSE:DATA:TELEcom:JITter (SDH/PDH Jitter/Wander Test Option Only)

## INPUT1 Subsystem

This section describes the commands and queries that allow you to set the rate, type, and level of the incoming signal. Figure 2–22 shows the hierarchy tree for this subsystem.

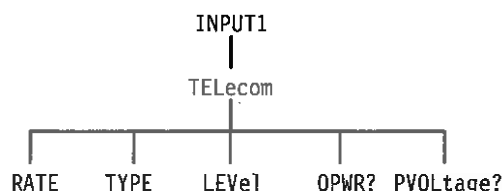

Figure 2–22: INPUT1 subsystem

### INPUT1:TELEcom:RATE

This command sets or queries the signal rate of the receiver. The signal connected to INPUT1 is passed to the receiver by the SENSE:DATA:TELEcom:SOURce INPUT1 command.

**Syntax** INPUT1:TELEcom:RATE <rate>  
INPUT1:TELEcom:RATE?

Parameters	<rate> (discrete)	Description
	STM0	51.84 MHz
	STM1	155.52 MHz (default)
	STM4	622.08 MHz

**Dependencies** None

**Errors and Events** 221, “Settings conflict; Rate is not available with current Line Interface module or operating mode”

**Examples** Set: INPUT1:TELECOM:RATE STM1  
 Query: INPUT1:TELECOM:RATE?  
 Response: STM1

**Related Commands** SENSE:DATA:TELEcom:SOURce

## INPUT1:TELEcom:TYPE

This command sets or queries the input signal type. The Operation Complete bit in the Standard Event Status Register is set to 1 when this command is executed.

**Syntax** INPUT1:TELEcom:TYPE <type>  
 INPUT1:TELEcom:TYPE?

Parameters	<type> (discrete)	Description
	ELECTrical	Electrical output (default)
	OPTical	Optical output

**Dependencies** None

**Errors and Events** 221, "Settings conflict; Type is not available with current Line Interface module"

**Examples** Set: INPUT1:TELECOM:TYPE ELECTRICAL  
 Query: INPUT1:TELECOM:TYPE?  
 Response: OPTICAL

**Related Commands** None

## INPUT1:TELEcom:LEVel

This command sets or queries the expected level of the received electrical signal.

Some optical and electrical modules do not support all levels. Check the status event register to verify valid settings.

**Syntax** INPUT1:TELEcom:LEVel <level>  
 INPUT1:TELEcom:LEVel?

Parameters	<level> (discrete)	Description
	XCONnect	Simulates cross connect level (-6 dB) (default)
	LOW	Input level is low (-12 dB)
	HIGH	High level (0 dB)
	MONITOR	Monitor level

**Dependencies** INPUT1:TELEcom:TYPE must be set to ELECTrical for this command to apply.

**Errors and Events** 221, "Settings conflict; Level is not available with current type, must be electrical"

**Examples**  
 Set: INPUT1:TELECOM:LEVEL XCON  
 Query: INPUT1:TELECOM:LEVEL?  
 Response: HIGH

**Related Commands** INPUT1:TELEcom:TYPE



**INPUT1:TELEcom:STATus?**

This query returns the status of the received signal connected to INPUT1. The response is valid only when the receiver is set up to receive signals.

**Syntax** INPUT1:TELEcom:STATus?

**Response Dependencies** None

**Errors and Events** None

**Examples**  
 Query: INPUT1:TELECOM:STATUS?  
 Response: MONITOR

**Related Commands** INPUT1:TELEcom:LEVel

**INPUT1:TELEcom:OPWR?**

This query returns the optical signal level in dBm.

**Syntax** INPUT1:TELEcom:OPWR?

Response	<optical level> (NR3-numeric)	Description
	Any floating point number	The optical signal level of the received signal in dBm

**Dependencies** INPUT1:TELEcom:TYPE must be set to OPTical.

**Errors and Events** None

**Examples**  
 Query: INPUT1:TELECOM:OPWR?  
 Response: -25.0

**Related Commands** INPUT1:TELEcom:TYPE

## INPUT1:TELEcom:PVOLtage?

This query returns the peak electrical voltage in volts.

**Syntax** INPUT1:TELEcom:PVOLtage?

Response	<peak voltage> (NR3-numeric)	Description
	Any floating point number	The peak voltage of the received signal in volts

**Dependencies** INPUT1:TELEcom:TYPE must be set to ELECtrical.

**Errors and Events** None

**Examples**  
 Query: INPUT1:TELECOM:PVOLTAGE?  
 Response: 0.52

**Related Commands** INPUT1:TELEcom:TYPE

## INPUT2 Subsystem

Add/Drop Test Option Only

This section describes the commands and queries that set the characteristics of the received or added 2 Mb/s tributary signal. Figure 2–23 shows the hierarchy tree for this subsystem.

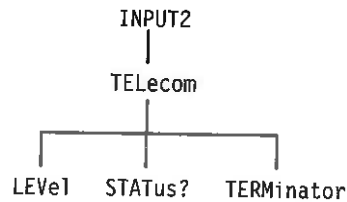

Figure 2–23: INPUT2 subsystem

### INPUT2:TELEcom:LEVe1

Add/Drop Test Option Only

This command sets or queries the expected signal level at the 2 Mb/s receive connector.

**Syntax** INPUT2:TELEcom:LEVe1 <trib1 input level>  
INPUT2:TELEcom:LEVe1?

Parameters	<trib1 input level> (discrete)	Description
	NORMal	Normal input levels (default)
	MONitor	Monitor level
	BRIDge	Bridged input

**Dependencies** The instrument must be set up to receive or add a 2 Mb/s tributary signal for this command to apply.

**Errors and Events** None

**Examples**    Set:        INPUT2:TELECOM:LEVEL NORMAL  
                   Query:      INPUT2:TELECOM:LEVEL?  
                   Response: MONITOR

**Related Commands**    SENSE:DATA:TELEcom:SOURce  
                               SOURce:DATA:TELEcom:TRIButary:ADD

## INPUT2:TELEcom:STATus?

Add/Drop Test Option Only

This query returns the status of the received or added 2 Mb/s tributary signal.

**Syntax**    INPUT2:TELEcom:STATus?

**Response**

<trib1 input status> (discrete)	Description
NORMAL	Signal is of acceptable quality
LOSignal	Loss of Signal (no signal connected)

**Dependencies**    SENSE:DATA:TELEcom:SOURce must be set to INPUT2 for this command to apply.

**Errors and Events**    None

**Examples**    Query:      INPUT2:TELECOM:STATUS?  
                   Response: NORMAL

**Related Commands**    SENSE:DATA:TELEcom:SOURce

## INPUT2:TELEcom:TERMinator

Add/Drop Test Option Only

This command sets or queries the signal terminator for the 2 Mb/s receive connector.

**Syntax** INPUT2:TELEcom:TERMinator <trib1 input termin>  
INPUT2:TELEcom:TERMinator?

Parameters	<trib1 input termin> (discrete)	Description
	BALanced	120 $\Omega$ connector (default)
	UNBALanced	75 $\Omega$ connector

**Dependencies** The instrument must be set up to receive or add a 2 Mb/s tributary signal for this command to apply.

**Errors and Events** None

**Examples**

Set: INPUT2:TELECOM:TERMINATOR BALANCED

Query: INPUT2:TELECOM:TERMINATOR?

Response: STM1

Response: M155

**Related Commands** SENSE:DATA:TELEcom:SENSe  
SOURCE:DATA:TELEcom:TRIButary:ADD

## INPUT3 Subsystem

Add/Drop Test Option Only

This section describes the commands and queries that set the characteristics of the received or added 34 Mb/s or 140 Mb/s tributary signal. Figure 2–24 shows the hierarchy tree for this subsystem.

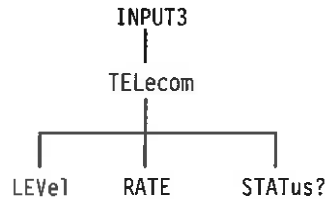

Figure 2–24: INPUT3 subsystem

### INPUT3:TELEcom:LEVe1

Add/Drop Test Option Only

This command sets or queries the expected signal level at the 34 Mb/s or 140 Mb/s receive connector.

**Syntax** INPUT3:TELEcom:LEVe1 <trib2 input level>  
 INPUT3:TELEcom:LEVe1?

Parameters	<trib2 input level> (discrete)	Description
	NORMal	Normal input level
	MONitor	Monitor level

**Dependencies** The instrument must be set up to receive or add a 34 Mb/s or 140 Mb/s tributary signal for this command to apply.

**Errors and Events** None

**Examples** Set: INPUT3:TELECOM:LEVEL NORMAL  
 Query: INPUT3:TELECOM:LEVEL?  
 Response: NORMAL

**Related Commands** None

## INPUT3:TELEcom:RATE

Add/Drop Test Option Only

This command sets or queries the 34 Mb/s or 140 Mb/s tributary input rate.

**Syntax** INPUT3:TELEcom:RATE <trib2 input rate>  
 INPUT3:TELEcom:RATE?

### Parameters

<trib2 input rate> (discrete)	Description
M34	34.368 Mb/s (default)
M140	139.264 Mb/s

**Dependencies** The instrument must be set up to receive or add a 34 Mb/s or 140 Mb/s tributary signal for this command to apply.

**Errors and Events** None

**Examples** Set: INPUT3:TELECOM:RATE M34  
 Query: INPUT3:TELECOM:RATE?  
 Response: M140

**Related Commands** SENSE:DATA:TELEcom:SOURce

## INPUT3:TELEcom:STATus?

Add/Drop Test Option Only

This query returns the status of the received or added 34 Mb/s or 140 Mb/s tributary signal.

**Syntax** INPUT3:TELEcom:STATus?

Response	<trib2 input status> (discrete)	Description
	NORMal	Signal is of acceptable quality
	LOSignal	Loss of Signal (no signal connected)

**Dependencies** SENSE:DATA:TELEcom:SOURce must be set to INPUT3 for this query to apply.

**Errors and Events** None

**Examples**  
 Query: INPUT3:TELECOM:STATUS?  
 Response: NORMAL

**Related Commands** SENSE:DATA:TELEcom:SOURce



## SENSe:DATA:TELEcom Subsystem

This section describes the commands and queries that set up the structure of the signal to be received. Figure 2–25 shows the hierarchy tree for this subsystem.

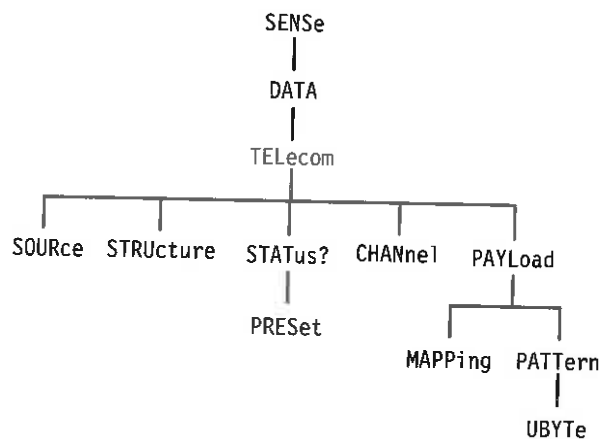

Figure 2–25: SENSE:DATA:TELEcom subsystem

## SENSe:DATA:TELEcom:SOURce

This command sets or queries the input signal source.

**Syntax** SENSE:DATA:TELEcom:SOURce <source>  
SENSe:DATA:TELEcom:SOURce?

Parameters	<source> (discrete)	Description
	INPUT1	SDH rates (default)
	INPUT2	2 Mb/s rate (Add/Drop Test Option Only)
	INPUT3	34 Mb/s or 140 Mb/s rate (Add/Drop Test Option Only)

**Dependencies** None

**Errors and Events** None

**Examples**    Set:        SENSE:DATA:TELECOM:SOURCE INPUT1  
                   Query:       SENSE:DATA:TELECOM:SOURCE?  
                   Response: INPUT2

**Related Commands**    INPUT1:TELEcom:RATE

## SENSe:DATA:TELEcom:STRUcture

This command sets or queries the input signal structure.

**Syntax**    SENSE:DATA:TELEcom:STRUcture <input structure>  
                   SENSE:DATA:TELEcom:STRUcture?

Parameters	<input structure> (discrete)	Description
	AU3	AU-3 structure (STM0 only)
	AU4	AU-4 structure (default) (STM1 and STM4 only)

**Dependencies**    AU3 is only available for the STM-0 rate

**Errors and Events**    221, "Settings conflict; Argument not valid in current instrument state"

**Examples**    Set:        SENSE:DATA:TELECOM:STRUCTURE AU4  
                   Query:       SENSE:DATA:TELECOM:STRUCTURE?  
                   Response: AU3

**Related Commands**    OUTPUT1:TELEcom:RATE

**SENSe:DATA:TELEcom:STATus?**

This query returns the historical or accumulated status of the received signal.

**Syntax**    SENSe:DATA:TELEcom:STATus?

<b>Response</b>	<b>&lt;decimal value&gt; (NR1-numeric)</b>	<b>bit</b>	<b>definition</b>
	1	0	LOS
	2	1	LOF
	4	2	OOF
	8	3	LOP
	16	4	MS AIS
	32	5	Path AIS
	64	6	Error
	128	7	Undefined
	256	8	K1/K2 change
	512	9	MS FERF
	1024	10	Path FERF
	2048	11	Pointer adjust
	4096	12	NDF
	8192	13	Pattern lock
	16384	14	Not used
	32768	15	Not used

**Dependencies**    None

**Errors and Events**    None

**Examples**    Query:    SENSe:DATA:TELECOM:STATUS?

Response: 1024

**Related Commands**    SENSe:DATA:TELEcom:STATus:PRESet

## SENSe:DATA:TELEcom:STATus:PRESet

This command clears the status of the received SDH and tributary signals by setting each status bit to 0. After this command is given, the status information is accumulated until another SENSE:DATA:TELEcom:STATus:PRESet command is given. To get the current signal status without any history information, send the SENSE:DATA:TELEcom:STATus:PRESet::SENSe:DATA:TELEcom:STATus? chained command.

<b>Syntax</b>	SENSe:DATA:TELEcom:STATus:PRESet
<b>Parameters</b>	None
<b>Dependencies</b>	None
<b>Errors and Events</b>	None
<b>Examples</b>	SENSe:DATA:TELECOM:STATUS:PRESET
<b>Related Commands</b>	SENSe:DATA:TELEcom:STATus?

## SENSe:DATA:TELEcom:CHANnel

This command sets or queries the active channel to test (a VC structure).

<b>Syntax</b>	SENSe:DATA:TELEcom:CHANnel <channel> SENSe:DATA:TELEcom:CHANnel?							
<b>Parameters</b>	<table border="1"> <thead> <tr> <th>&lt;channel&gt; (NR1-numeric)</th> <th>Description</th> </tr> </thead> <tbody> <tr> <td>1</td> <td>STM-0, STM-1 (default)</td> </tr> <tr> <td>1 to 4</td> <td>STM-4 rate</td> </tr> </tbody> </table>	<channel> (NR1-numeric)	Description	1	STM-0, STM-1 (default)	1 to 4	STM-4 rate	
<channel> (NR1-numeric)	Description							
1	STM-0, STM-1 (default)							
1 to 4	STM-4 rate							
<b>Dependencies</b>	Selection of a <channel> greater than 1 implies a rate and structure with multiple VCs.							
<b>Errors and Events</b>	221, "Settings conflict; Channel is out of range"							

**Examples** Set: SENSE:DATA:TELECOM:CHANNEL 1  
 Query: SENSE:DATA:TELECOM:CHANNEL?  
 Response: 3

**Related Commands** INPUT1:TELEcom:RATE  
 SENSE:DATA:TELEcom:STRUcture

## SENSE:DATA:TELEcom:PAYLoad:MAPPING

This command sets or queries the payload mapping of the received structure.

**Syntax** SENSE:DATA:TELEcom:PAYLoad:MAPPING <payload\_mapping>  
 SENSE:DATA:TELEcom:PAYLoad:MAPPING?

### Parameters

<mapping> (discrete)	Description
EQUIpped	Expecting equipped payload mapping (default)
UNEQUIpped	Expecting unequipped payload mapping
TRIButary	Expecting tributary payload mapping (Add/Drop Test Option Only)

**Dependencies** Select EQUIpped or UNEQUIpped to use the SENSE:DATA:TELEcom:PAYLoad:PATtern command. Selection of TRIButary is not allowed for the STM-0 rate. TRIButary is invalid for an AU-3 structure.

**Errors and Events** 221, "Settings conflict; Not available without tributary option"

**Examples** Set: SENSE:DATA:TELECOM:PAYLOAD:MAPPING EQUIPPED  
 Query: SENSE:DATA:TELECOM:PAYLOAD:MAPPING?  
 Response: TRIBUTARY

**Related Commands** SENSE:DATA:TELEcom:PAYLoad:PATtern

## SENSe:DATA:TELEcom:PAYLoad:PATtern

This command sets or queries the payload pattern that will be used to calculate the payload BER of the incoming data.

**Syntax** SENSe:DATA:TELEcom:PAYLoad:PATtern <pattern>  
SENSe:DATA:TELEcom:PAYLoad:PATtern?

Parameters	<pattern> (discrete)	Description
	PRBS23	A pseudo-random binary sequence of length $2^{23}-1$ (default)
	PRBS9	A pseudo-random binary sequence of length $2^9-1$
	PRBS15	A pseudo-random binary sequence of length $2^{15}-1$
	PRBS20	A pseudo-random binary sequence of length $2^{20}-1$
	AZERos	All zeros
	AONEs	All ones
	UBYTE	A user-defined byte
	UNKNown	Disable BER calculations on incoming data

**Dependencies** None

**Errors and Events** None

**Examples**  
Set: SENSe:DATA:TELECOM:PAYLOAD:PATTERN PRBS23  
Query: SENSe:DATA:TELECOM:PAYLOAD:PATTERN?  
Response: PRBS9

**Related Commands** SENSe:DATA:TELEcom:CHANnel  
SENSe:DATA:TELEcom:PAYLoad:PATtern:UBYTE

**SENSe:DATA:TELEcom:PAYLoad:PATtern:UBYTE**

This command sets or queries the internally generated payload fixed pattern to be detected in the incoming signal.

**Syntax** SENSe:DATA:TELEcom:PAYLoad:PATtern:UBYTE <fixed pattern>SENSe:DATA:TELEcom:PAYLoad:PATtern:UBYTE?

Parameters	<fixed pattern> (NR1-numeric) <sup>4</sup>	Description
	A number in the range 0 to 255 (hexadecimal 00 to FF)	The payload pattern to be detected is set to this value (default = 0)
	<sup>4</sup> A hexadecimal value is also acceptable.	

**Dependencies** SENSe:DATA:TELEcom:PAYLoad:PATtern must be set to UBYTE for this command to apply.

**Errors and Events** None

**Examples**

Set:       SENSe:DATA:TELECOM:PAYLOAD:PATTERN:UBYTE 01  
SENSe:DATA:TELECOM:PAYLOAD:PATTERN:UBYTE #HA5

Query:     SENSe:DATA:TELECOM:PAYLOAD:PATTERN:UBYTE?

Response:  128

**Related Commands** SENSe:DATA:TELEcom:PAYLoad:PATtern

## SENSe:DATA:TELEcom:TEST Subsystem

This section describes each of the commands and queries used to control measurements. Figure 2–26 shows the hierarchy tree for this subsystem.

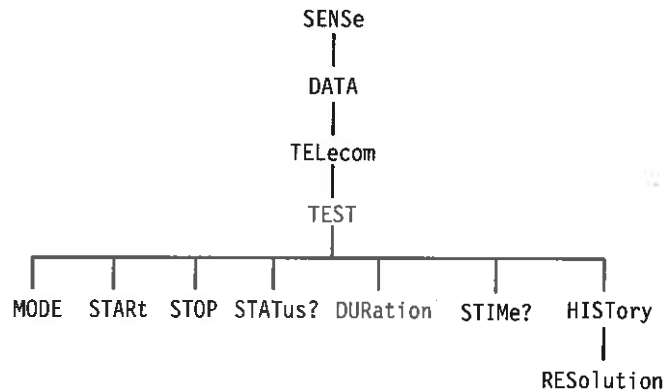

Figure 2–26: SENSE:DATA:TELEcom:TEST subsystem

## SENSe:DATA:TELEcom:TEST:MODE

SDH/PDH Jitter/Wander Test Option Only

This command sets or queries the measurement test mode (normal or jitter).

**Syntax** SENSE:DATA:TELEcom:TEST:MODE <mode>  
SENSe:DATA:TELEcom:TEST:MODE?

Parameters	<mode> (discrete)	Description
	NORMAl	Normal operation jitter measurements (default)
	JITter	Enable compliance tests

**Dependencies** Requires installation of Option 14 jitter module.

\*RST sets mode to normal (default).

**Errors and Events** 221, “Settings conflict; Not available without jitter option” if the jitter/wander test option is not installed and JITter is specified.



**Examples** Set: SENSE:DATA:TELECOM:TEST:MODE JITTER  
Query: SENSE:DATA:TELECOM:TEST:MODE?  
Response: NORMAL

**Related Commands** None

## SENSe:DATA:TELEcom:TEST:START

This command starts normal test measurements if SENSe:DATA:TELEcom:TEST:MODE is set to NORMAl. This command starts specified jitter compliance tests if SENSe:DATA:TELEcom:TEST:MODE is set to JITter.

**Syntax** SENSe:DATA:TELEcom:TEST:START

**Parameters** None

**Dependencies** Any instrument settings can be changed after a test is started, but the measurements are restarted when any change is made to the receiver rate, level, structure, or pattern.

**Errors and Events** None

**Examples** SENSE:DATA:TELECOM:TEST:START

**Related Commands** SENSe:DATA:TELEcom:TEST:STOP  
SENSe:DATA:TELEcom:TEST:MODE

## SENSe:DATA:TELEcom:TEST:STOP

This command stops normal or compliance measurements.

<b>Syntax</b>	SENSe:DATA:TELEcom:TEST:STOP
<b>Parameters</b>	None
<b>Dependencies</b>	None
<b>Errors and Events</b>	None
<b>Examples</b>	SENSe:DATA:TELECOM:TEST:STOP
<b>Related Commands</b>	SENSe:DATA:TELEcom:TEST:START

## SENSe:DATA:TELEcom:TEST:STATus?

This query returns the state of the measurement process and how long the test has been running.

<b>Syntax</b>	SENSe:DATA:TELEcom:TEST:STATus?																						
<b>Response</b>	<table border="1"> <thead> <tr> <th>&lt;status&gt;(boolean)</th> <th>Description</th> </tr> </thead> <tbody> <tr> <td>1</td> <td>Test is running</td> </tr> <tr> <td>0</td> <td>Test is stopped</td> </tr> <tr> <th>&lt;days&gt; (NR1-numeric)</th> <th>Description</th> </tr> <tr> <td>Any number in the range 0 to 999</td> <td>Number of days the test has been running</td> </tr> <tr> <th>&lt;hours&gt; (NR1-numeric)</th> <th>Description</th> </tr> <tr> <td>Any number in the range 0 to 23</td> <td>Number of hours the test has been running</td> </tr> <tr> <th>&lt;minutes&gt; (NR1-numeric)</th> <th>Description</th> </tr> <tr> <td>Any number in the range 0 to 59</td> <td>Number of minutes the test has been running</td> </tr> <tr> <th>&lt;seconds&gt; (NR1-numeric)</th> <th>Description</th> </tr> <tr> <td>Any number in the range 0 to 59</td> <td>Number of seconds the test has been running</td> </tr> </tbody> </table>	<status>(boolean)	Description	1	Test is running	0	Test is stopped	<days> (NR1-numeric)	Description	Any number in the range 0 to 999	Number of days the test has been running	<hours> (NR1-numeric)	Description	Any number in the range 0 to 23	Number of hours the test has been running	<minutes> (NR1-numeric)	Description	Any number in the range 0 to 59	Number of minutes the test has been running	<seconds> (NR1-numeric)	Description	Any number in the range 0 to 59	Number of seconds the test has been running
<status>(boolean)	Description																						
1	Test is running																						
0	Test is stopped																						
<days> (NR1-numeric)	Description																						
Any number in the range 0 to 999	Number of days the test has been running																						
<hours> (NR1-numeric)	Description																						
Any number in the range 0 to 23	Number of hours the test has been running																						
<minutes> (NR1-numeric)	Description																						
Any number in the range 0 to 59	Number of minutes the test has been running																						
<seconds> (NR1-numeric)	Description																						
Any number in the range 0 to 59	Number of seconds the test has been running																						

**Dependencies** None

**Errors and Events** None

**Examples** Query: SENSE:DATA:TELECOM:TEST:STATUS?

Response: 1,0,0,13,5

This response indicates that the test has been running for 13 minutes and 5 seconds and is still running.

**Related Commands** None

## SENSe:DATA:TELEcom:TEST:DURation

This command sets or queries the length of the test. If all four parameters are set to 0, the test will run continuously.

**Syntax** SENSE:DATA:TELEcom:TEST:DURation <d>,<hrs>,<min>,<sec>  
SENSe:DATA:TELEcom:TEST:DURation?

Parameters		Description
	<b>&lt;days&gt; (NR1-numeric)</b>	
	Any number in the range 0 to 99	Specifies the number of days the test is to be run (default = 0)
	<b>&lt;hours&gt; (NR1-numeric)</b>	
	Any number in the range 0 to 23	Specifies the number of hours the test is to be run (default = 0)
	<b>&lt;minutes&gt; (NR1-numeric)</b>	
	Any number in the range 0 to 59	Specifies the number of minutes the test is to be run (default = 0)
	<b>&lt;seconds&gt; (NR1-numeric)</b>	
	Any number in the range 0 to 59	Specifies the number of seconds the test is to be run (default = 0)

**Dependencies** None

**Errors and Events** None

**Examples**    Set:            SENSE:DATA:TELECOM:TEST:DURATION 1,12,30,0

The above example sets the test duration to 1 day, 12 hours, 30 minutes, and 0 seconds.

Query:        SENSE:DATA:TELECOM:TEST:DURATION?

Response:    0,2,0,0

**Related Commands**    None

### SENSe:DATA:TELEcom:TEST:STIME?

This query returns the date and time the test was started.

**Syntax**            SENSe:DATA:TELEcom:TEST:STIME?

**Response**

<b>&lt;year&gt; (NR1-numeric)</b>	<b>Description</b>
Any number in the range 00 to 99	Specifies the year the test was started; "92" indicates that the test was started in 1992, "01" indicates the year 2001
<b>&lt;month&gt; (NR1-numeric)</b>	<b>Description</b>
Any number in the range 1 to 12	Specifies the month the test was started; "09" indicates that the test was started in September
<b>&lt;day&gt; (NR1-numeric)</b>	<b>Description</b>
Any number in the range 1 to 31	Specifies the day of the month the test was started
<b>&lt;hours&gt; (NR1-numeric)</b>	<b>Description</b>
Any number in the range 0 to 23	Specifies the hour the test was started
<b>&lt;minutes&gt; (NR1-numeric)</b>	<b>Description</b>
Any number in the range 0 to 59	Specifies the minute the test was started
<b>&lt;seconds&gt; (NR1-numeric)</b>	<b>Description</b>
Any number in the range 0 to 59	Specifies the seconds the test was started

**Dependencies**    None

**Errors and Events**    None

**Examples**    Query:    SENSE:DATA:TELECOM:TEST:STIME?  
 Response: 93,10,25,22,15,00  
 This test was started on October 25, 1993 at 10:15 pm.

**Related Commands**    SENSE:DATA:TELECOM:TEST:START

## SENSE:DATA:TELECOM:TEST:HISTORY:RESOLUTION

This command sets or queries the resolution of the history data.

This command does not affect previously acquired history data. This command assigns the size of data "buckets" prior to starting a new test.

**Syntax**    SENSE:DATA:TELECOM:TEST:HISTORY:RESOLUTION <hist res>  
 SENSE:DATA:TELECOM:TEST:HISTORY:RESOLUTION?

### Parameters

<hist res> (discrete)	Description
SEC1	1 second resolution
MIN1	1 minute resolution (default)
MIN15	15 minute resolution

**Dependencies**    None

**Errors and Events**    None

**Examples**    Set:    SENSE:DATA:TELECOM:TEST:HISTORY:RESOLUTION MIN15  
 Query:    SENSE:DATA:TELECOM:TEST:HISTORY:RESOLUTION?  
 Response: MIN1

**Related Commands**    SENSE:DATA:TELECOM:TEST:START  
 SENSE:DATA:TELECOM:MEASURE:HISTORY

## SENSe:DATA:TELEcom:TEST:JITter Subsystem

This section describes the commands and queries that control the jitter and wander measurements. Figure 2–27 shows the hierarchy tree for this subsystem.

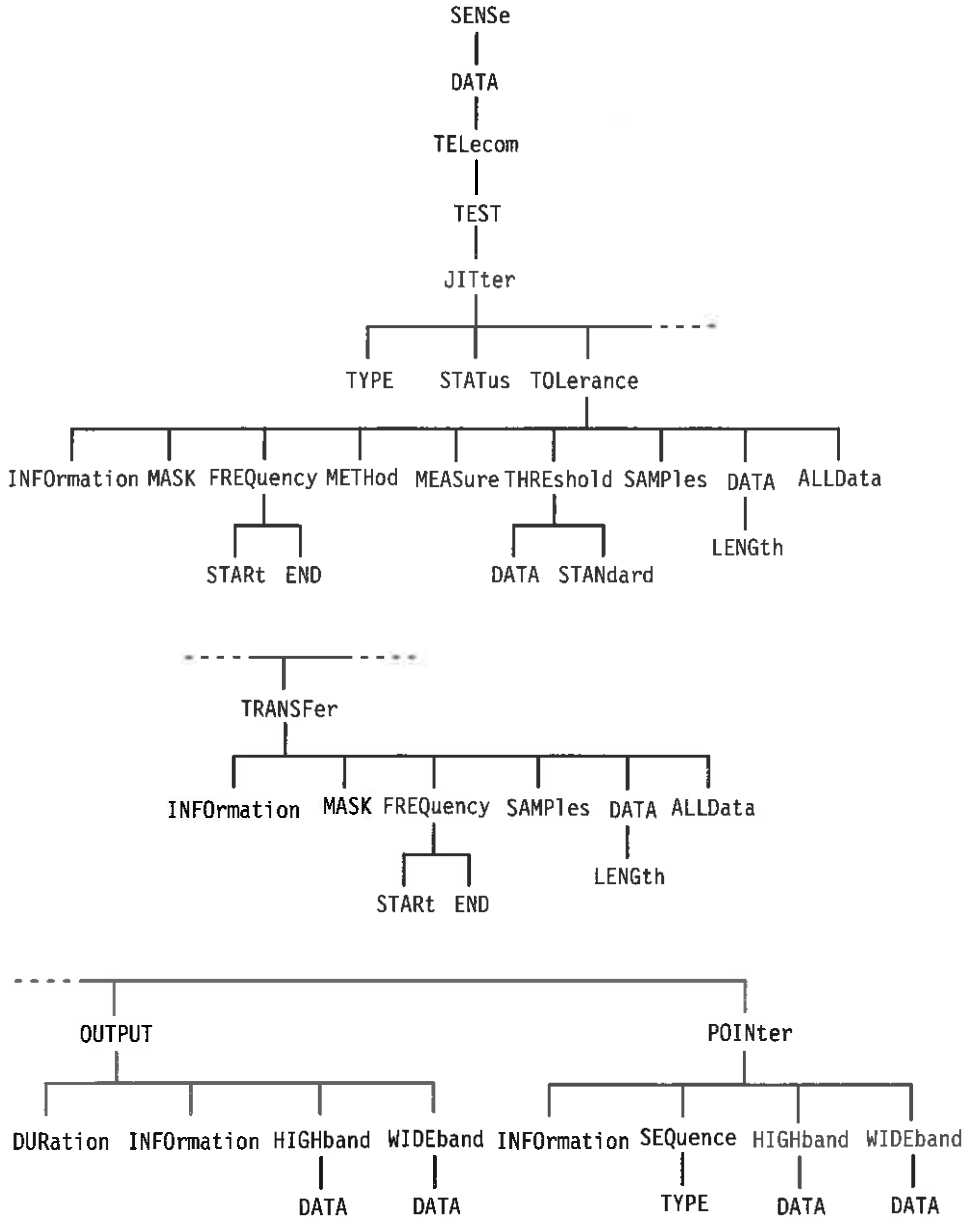

Figure 2–27: SENSE:DATA:TELEcom:TEST:JITter subsystem

**SENSe:DATA:TELEcom:TEST:JITter:TYPE**

SDH/PDH Jitter/Wander Test Option Only

This command sets or queries a pre-defined jitter compliance test.

**Syntax**    `SENSe:DATA:TELEcom:TEST:JITter:TYPE <jitter test>`  
`SENSe:DATA:TELEcom:TEST:JITter:TYPE?`

Parameters	<jitter test> (discrete)	Description
	TOLerance	Maximum tolerable jitter test
	TRANSFer	Transfer jitter line-to-line test or jitter synchronization source-to-line test
	OUTPUT	Output jitter test (default)
	POINter	Pointer jitter test

**Dependencies**    Requires installation of Option 14 jitter module.

\*RST sets jitter test to OUTPUT (default).

**Errors and Events**    None

**Examples**    Set:        `SENSe:DATA:TELECOM:TEST:JITTER:TYPE OUTPUT`

Query:      `SENSe:DATA:TELECOM:TEST:JITTER:TYPE?`

Response:   `TRANSFER`

**Related Commands**    None

## SENSe:DATA:TELEcom:TEST:JITter:STATus?

SDH/PDH Jitter/Wander Test Option Only

This query returns the current jitter compliance test status.

**Syntax** SENSe:DATA:TELEcom:TEST:JITter:STATus?

Response	<jitter stat> (discrete)	Description
	STOP	Jitter test is not running
	RUN	Jitter test is running

**Dependencies** None

**Errors and Events** None

**Examples**  
 Query: SENSe:DATA:TELECOM:TEST:JITTER:STATUS?  
 Response: STOP

**Related Commands** SENSe:DATA:TELEcom:TEST:STARt

## SENSe:DATA:TELEcom:TEST:JITter:TOLerance:INFOrmation?

SDH/PDH Jitter/Wander Test Option Only

This query returns jitter tolerance test settings.

**Syntax** SENSe:DATA:TELEcom:TEST:JITter:TOLerance:INFOrmation:<info>?

Parameters	<info> (discrete)	Description
	SOURce	Results source
	TIME	Test start time
	DATE	Test start date
	TXRate	Transmitted signal rate
	RXRate	Received signal rate

*(continued on next page)*



<info> (discrete)	Description
TXMask	Transmitted signal mask
FREQStart	Mask start frequency
FREQEnd	Mask end frequency
SAMPles	Maximum number of samples in mask

## Response

SOURCE	Description
NONE	Results not available
MEMory	Results read from instrument memory
DISK	Results read from disk

TIME	Description
HH:MM:SS	Test start time (hr, min, sec)

DATE	Description
YY:MM:DD	Test start date (yr, mo, day)

TXRate	Description
M52	52 Mb/s (STM-0)
M155	155 Mb/s (STM-1)
M622	622 Mb/s (STM-4)
M2	2 Mb/s
M34	34 Mb/s
M140	140 Mb/s

RXRate	Description
M52	52 Mb/s (STM-0)
M155	155 Mb/s (STM-1)
M622	622 Mb/s (STM-4)
M2	2 Mb/s
M34	34 Mb/s
M140	140 Mb/s

<b>TXMask</b>	<b>Description</b>
GR253	GR-253 Standard mask (valid for 52 Mb/s)
G825	G.825 Standard mask (valid for 155 and 622 Mb/s)
TYPEA	G.958 Type A equipment mask (valid for 155 and 622 Mb/s)
TYPEB	G.958 Type B equipment mask (valid for 155 and 622 Mb/s)
LOWQ	G.823 Low Q mask (valid for 2 Mb/s)
HIGHQ	G.823 High Q mask (valid for 2 Mb/s)
G823	G.823 Standard mask (valid for 34 and 144 Mb/s)

<b>FREQStart</b>	<b>Description</b>
Floating point value in Hz	Frequency start

<b>FREQEnd</b>	<b>Description</b>
Floating point value in Hz	Frequency end

<b>SAMPles</b>	<b>Description</b>
Integer value	Maximum number of samples

**Dependencies** None

**Errors and Events** None

**Examples** Query: SENSE:DATA:TELECOM:TEST:JITTER:TOLERANCE: INFORMATION:RXRATE?  
 Response: M155

**Related Commands** None

**SENSe:DATA:TELEcom:TEST:JITter:TOLerance:MASK**

SDH/PDH Jitter/Wander Test Option Only

This command sets or queries the jitter tolerance test mask.

**Syntax**    **SENSe:DATA:TELEcom:TEST:JITter:TOLerance:MASK** <jitter mask>  
**SENSe:DATA:TELEcom:TEST:JITter:TOLerance:MASK?**

<b>Parameters</b>	<b>&lt;jitter mask&gt; (discrete)</b>	<b>Description</b>
	GR253	GR-253 Standard mask (valid for 52 Mb/s, default for 52 Mb/s)
	G825	G.825 Standard mask (valid for 155 and 622 Mb/s)
	TYPEA	G.958 Type A equipment mask (valid for 155 and 622 Mb/s, default for 155 and 622 Mb/s)
	TYPEB	G.958 Type B equipment mask (valid for 155, and 622 Mb/s)
	LOWQ	G.823 Low Q mask (valid for 2 Mb/s, default for 2 Mb/s)
	HIGHQ	G.823 High Q mask (valid for 2 Mb/s)
	G823	G.823 Standard mask (valid for 34 and 144 Mb/s, default for 34 and 144 Mb/s)

**Dependencies**    Requires installation of Option 14 jitter module.

\*RST sets the jitter mask to default.

**Errors and Events**    221, "Settings conflict"  
if the value entered is not valid for the current receive rate.

**Examples**

Set:            **SENSe:DATA:TELECOM:TEST:JITTER:TOLERANCE:MASK TYPEA**

Query:        **SENSe:DATA:TELECOM:TEST:JITTER:TOLERANCE:MASK?**

Response:    **TYPEA**

**Related Commands**    **SENSe:DATA:TELEcom:TEST:JITter**

**SENSe:DATA:TELEcom:TEST:JITter:TOLerance:FREQuency:STARt**

SDH/PDH Jitter/Wander Test Option Only

This command sets or queries the jitter tolerance test start frequency.

**Syntax**    SENSe:DATA:TELEcom:TEST:JITter:TOLerance:FREQuency:STARt  
              <tol freq start>  
              SENSe:DATA:TELEcom:TEST:JITter:TOLerance:FREQuency:STARt?

**Parameters**

<tol freq start> (NR3-numeric)	Description
Floating point number in range from 0 to the end frequency	Start frequency in Hz

**Dependencies**\*RST sets the tolerance frequency start point to 125  $\mu$ Hz (default).

Value must be less than end frequency.

**Errors and Events**500, "Execution warning"  
if the entered value is out of range for the command.**Examples**Set:        SENSe:DATA:TELECOM:TEST:JITTER:TOLERANCE  
             :FREQUENCY:START 1000.0Query:     SENSe:DATA:TELECOM:TEST:JITTER:TOLERANCE  
             :FREQUENCY:START?

Response: 1200.0

**Related Commands**

SENSe:DATA:TELEcom:TEST:JITter:TOLerance:FREQuency:END

**SENSe:DATA:TELEcom:TEST:JITter:TOLerance:FREQuency:END**

SDH/PDH Jitter/Wander Test Option Only

This command sets or queries the jitter tolerance test end frequency.

**Syntax**    **SENSe:DATA:TELEcom:TEST:JITter:TOLerance:FREQuency:END**  
                  <tol freq end>  
**SENSe:DATA:TELEcom:TEST:JITter:TOLerance:FREQuency:END?**

Parameters	<tol freq end> (NR3-numeric)	Description
	Floating point number in range of greater than start frequency to 5 MHz	End frequency in Hz

**Dependencies**    Requires installation of Option 14 jitter module.  
                          \*RST sets the tolerance end frequency to 19.3 Hz (default).  
                          Value must be greater than starting frequency.

**Errors and Events**    500, "Execution warning"  
                          if the entered value is out of range for the command.

**Examples**    Set:            **SENSe:DATA:TELECOM:TEST:JITTER:TOLERANCE**  
    **:FREQUENCY:END 100000.0**  
                          Query:          **SENSe:DATA:TELECOM:TEST:JITTER:TOLERANCE:FREQUENCY:END?**  
                          Response:    120000.0

**Related Commands**    **SENSe:DATA:TELEcom:TEST:JITter:TOLerance:FREQuency:START**

**SENSe:DATA:TELEcom:TEST:JITter:TOLerance:METhod**

SDH/PDH Jitter/Wander Test Option Only

This command sets or queries the jitter tolerance compliance test error criteria method.

**Syntax** SENSE:DATA:TELEcom:TEST:JITter:Tolerance:METhod <test method>  
SENSe:DATA:TELEcom:TEST:JITter:Tolerance:METhod?

Parameters	<test method> (discrete)	Description
	ONSET_ERR	Onset of Errors method (default)
	BER	BER method

**Dependencies** Requires installation of Option 14 jitter module.

**Errors and Events** None.

**Examples**

Set: SENSE:DATA:TELECOM:TEST:JITTER:TOLERANCE  
:METHOD ONSET\_ERR

Query: SENSE:DATA:TELECOM:TEST:JITTER:TOLERANCE:METHOD?

Response: BER

**Related Commands** None

**SENSe:DATA:TELEcom:TEST:JITter:TOLerance:MEASure**

SDH/PDH Jitter/Wander Test Option Only

This command starts or stops the BER measurement threshold. When the instrument receives a stop command, it uses the last measured value as the threshold for the jitter tolerance calculations.

**Syntax** SENSE:DATA:TELEcom:TEST:JITter:Tolerance:MEASure <meas ctrl>  
SENSe:DATA:TELEcom:TEST:JITter:Tolerance:MEASure?

**Parameters**

<meas ctrl> (discrete)	Description
START	Start BER measurement
STOP	Stop and record BER measurement

**Dependencies**

Requires installation of Option 14 jitter module.

You can only use this command if the jitter tolerance error criteria is set to BER.

**Errors and Events**

None

**Examples**

Set: SENSE:DATA:TELECOM:TEST:JITTER:TOLERANCE:MEASURE START

Query: SENSE:DATA:TELECOM:TEST:JITTER:TOLERANCE:MEASURE?

Response: STOP

**Related Commands**

SENSe:DATA:TELEcom:TEST:JITter:TOLerance:METhod

## SENSe:DATA:TELEcom:TEST:JITter:TOLerance:THREShold:DATA?

SDH/PDH Jitter/Wander Test Option Only

This query returns the last measured BER value to use as the threshold for the jitter tolerance BER compliance test.

**Syntax**      SENSe:DATA:TELEcom:TEST:JITter:TOLerance:THREShold:DATA?

Response	<BER value> (NR3-numeric)	Description
	Floating point number in the range of 1.0E-3 to 1.0E-9, or zero	Last measured BER value. A zero means that no BER value was measured (the JITter:TOLerance:MEASure test was not run or not stopped)

**Dependencies**      This query only applies if the jitter tolerance error criteria is set to BER.

**Errors and Events**      None

**Examples**      Query:      SENSe:DATA:TELECOM:TEST:JITTER:TOLERANCE:THRESHOLD:DATA?

Response: 4.89E-8

**Related Commands**      SENSe:DATA:TELEcom:TEST:JITter:TOLerance:MEthod  
 SENSe:DATA:TELEcom:TEST:JITter:TOLerance:MEASure



**SENSe:DATA:TELEcom:TEST:JITter:TOLerance:THREshold:STANdard?**

SDH/PDH Jitter/Wander Test Option Only

This query returns the recommended BER value (from 0.171) to use as the threshold for the jitter tolerance BER compliance test.

**Syntax** SENSE:DATA:TELEcom:TEST:JITter:TOLerance:THREshold:STANdard?

Response	<BER std> (NR3-numeric)	Description
	Floating point number in the approximate range of 1.0E-3 to 1.0E-9	Recommended BER value

**Dependencies** This query only applies if the jitter tolerance error criteria is set to BER.

**Errors and Events** None

**Examples** Query: SENSE:DATA:TELECOM:TEST:JITTER:TOLERANCE:THRESHOLD:STANDARD?

Response: 5.25E-6

**Related Commands** SENSE:DATA:TELEcom:TEST:JITter:TOLerance:METhod

**SENSe:DATA:TELEcom:TEST:JITter:TOLerance:SAMPles**

SDH/PDH Jitter/Wander Test Option Only

This command sets or queries the number of samples, including the corner frequencies for the jitter tolerance test mask.

**Syntax** SENSE:DATA:TELEcom:TEST:JITter:Tolerance:SAMPles <tol samples>  
SENSe:DATA:TELEcom:TEST:JITter:Tolerance:SAMPles?

Parameters	<tol samples> (NR1-numeric)	Description
	An integer in the range of 4 to 26	Number of samples including corner frequencies

**Dependencies** Requires installation of Option 14 jitter module.  
\*RST sets tolerance samples to 4 (default).

**Errors and Events** 500, "Execution warning"  
if the entered value is out of range for the command.

**Examples**  
Set: SENSE:DATA:TELECOM:TEST:JITTER:TOLERANCE:SAMPLES 4  
Query: SENSE:DATA:TELECOM:TEST:JITTER:TOLERANCE:SAMPLES?  
Response: 32

**Related Commands** None

### SENSE:DATA:TELECOM:TEST:JITTER:TOLERANCE:DATA:LENGTH?

SDH/PDH Jitter/Wander Test Option Only

This query returns the actual number of measurement samples in the jitter tolerance test.

**Syntax** SENSE:DATA:TELECOM:TEST:JITTER:TOLERANCE:DATA:LENGTH?

Response	<data length> (discrete)	Description
	An integer in the range of 0 to 26	Number of samples in the jitter tolerance test. A zero means that the instrument acquired no data or did not run the JITTER:TOLERANCE test.

**Dependencies** None

**Errors and Events** None

**Examples**  
Query: SENSE:DATA:TELECOM:TEST:JITTER:TOLERANCE:DATA:LENGTH?  
Response: 7

**Related Commands** None

**SENSe:DATA:TELecom:TEST:JITter:TOLerance:DATA?**

SDH/PDH Jitter/Wander Test Option Only

This query returns the status (frequency, amplitude, and mask values) of the specified jitter tolerance test sample. The response is a comma-separated list of values, in the order listed in the response table.

**Syntax**     **SENSe:DATA:TELecom:TEST:JITter:TOLerance:DATA? <N>**

Response	<N> (NR1-numeric)	Description
	Integer in the range of 1 to 26	Data sample number
	<freq> (NR3-numeric)	Description
	Floating point number in the range of 12 $\mu$ Hz to 5 MHz	Sample jitter frequency in Hz
	<amplitude> (NR3-numeric)	Description
	Floating point number in the range of 0 to 200	Computed jitter tolerance, in UI, for frequency <freq>
	<mask> (NR3-numeric)	Description
	Floating point number in the range of 0 to 200	Mask value, in UI, for frequency <freq>
	<data status> (discrete)	Description
	NONE	Measurement data empty
	VALID	Measurement data meets mask specifications
	FAILure	Measurement data fails mask specifications
	UNLOcked	Measurement invalid due to loss of signal (LOS), jitter over range, or pattern loss

**Dependencies**     None

**Errors and Events**     None

**Examples**    Query:    SENSE:DATA:TELECOM:TEST:JITTER:TOLERANCE:DATA? 1  
                   Response: 1, 500.0, 46.7, 39.0, VALID

**Related Commands**    SENSE:DATA:TELECOM:TEST:JITTER:TOLERANCE:DATA:LENGTH?

## SENSE:DATA:TELECOM:TEST:JITTER:TOLERANCE:ALLDATA?

SDH/PDH Jitter/Wander Test Option Only

This query returns the complete status (frequency, amplitude, and mask values) of the jitter tolerance test. The response is a comma-separated list of values, in the order listed in the response table.

**Syntax**    SENSE:DATA:TELECOM:TEST:JITTER:TOLERANCE:ALLDATA?

Response	<N><data-points>	Description
	<x1-freq>	Jitter frequency (Hz) of point 1
	<x1-ampl>	Jitter amplitude (UI) of point 1
	<x1-mask>	Mask amplitude (UI) of point 1
	<x1-status>	Data status of point 1
	...	...
	<xn-freq>	Jitter frequency (Hz) of point n
	<xn-ampl>	Jitter amplitude (UI) of point n
	<xn-mask>	Mask amplitude (UI) of point n
	<xn-status>	Data status of point n

Where n is the number of points returned by the SENSE:DATA:TELECOM:TEST:JITTER:TOLERANCE:DATA:LENGTH? command

<freq> (NR3-numeric)	Description
Floating point number in the range of 125 $\mu$ Hz to 5 MHz	Sample frequency in Hz

<b>&lt;amplitude&gt; (NR3-numeric)</b>	<b>Description</b>
Floating point number in the range of 0 to 200	Computed jitter tolerance, in UI, for frequency <freq>

<b>&lt;mask&gt; (NR3-numeric)</b>	<b>Description</b>
Floating point number in the range of 0 to 200	Mask value, in UI, for frequency <freq>

<b>&lt;data status&gt; (discrete)</b>	<b>Description</b>
NONE	No measurement data
VALID	Measurement data meets mask specifications
FAILure	Measurement data fails mask specifications
UNL0cked	Measurement invalid due to loss of signal (LOS), jitter over range, or pattern loss

**Dependencies** None

**Errors and Events** None

**Examples**  
 Query: SENSE:DATA:TELECOM:TEST:JITTER:TOLERANCE:ALLDATA?  
 Response: 20,1.2,1.8,VALID,100,2.0,2.8,VALID,100E+1,3.0,3.2,VALID,100E+2,20.0,18.2,00R

**Related Commands** SENSE:DATA:TELECOM:TEST:JITTER:TOLERANCE:DATA:LENGTH?

## SENSe:DATA:TELEcom:TEST:JITter:TRANSFer:INFOrmation?

SDH/PDH Jitter/Wander Test Option Only

This query returns jitter transfer test settings.

**Syntax** SENSe:DATA:TELEcom:TEST:JITter:TRANSFer:INFOrmation:<info>?

**Parameters**

<info> (discrete)	Description
SOURce	Results source
TIME	Test start time
DATE	Test start date
TXSource	Transmitted signal source
TXRate	Transmitted signal rate
RXRate	Received signal rate
TXMask	Transmit signal mask
FREQStart	Start frequency
FREQEnd	End frequency
SAMPles	Number of sample points

**Response**

SOURce	Description
NONE	Results not available
MEMory	Results read from instrument memory
DISK	Results read from disk

TIME	Description
HH:MM:SS	Test start time (hr, min, sec)

DATE	Description
YY:MM:DD	Test start date (yr, mo, day)

TXSource	Description
LINE	Transmit jitter source is line
CLOCK	Transmit jitter source is clock

<b>TXRate</b>	<b>Description</b>
M52	52 Mb/s (STM-0)
M155	155 Mb/s (STM-1)
M622	622 Mb/s (STM-4)
M2	2 Mb/s
M34	34 Mb/s
M140	140 Mb/s

<b>RXRate</b>	<b>Description</b>
M52	52 Mb/s (STM-0)
M155	155 Mb/s (STM-1)
M622	622 Mb/s (STM-4)
M2	2 Mb/s
M34	34 Mb/s
M140	140 Mb/s

<b>TXMask</b>	<b>Description</b>
GR253	GR-253 Standard mask (valid for 52 Mb/s)
TYPEA	G.958 Type A equipment mask (valid for 155 and 622 Mb/s)
TYPEB	G.958 Type B equipment mask (valid for 155 and 622 Mb/s)
G735	G.735 Standard mask (valid for 2 Mb/s)
G751	G.751 Standard mask (valid for 34 Mb/s)
UNDEFined	Undefined Standard mask (valid for 144 Mb/s)

<b>FREQStart</b>	<b>Description</b>
Floating point value in Hz	Frequency start

<b>FREQEnd</b>	<b>Description</b>
Floating point value in Hz	Frequency end

<b>SAMPles</b>	<b>Description</b>
Integer value	Maximum number of samples

**Dependencies**    None

**Errors and Events**    None

**Examples**    Query:    SENSE:DATA:TELECOM:TEST:JITTER:TRANSFER:INFO:TXS?  
                   Response: LINE

**Related Commands**    None

## SENSe:DATA:TELEcom:TEST:JITter:TRANSFer:MASK

SDH/PDH Jitter/Wander Test Option Only

This command sets or queries the mask for the jitter transfer test.

**Syntax**    SENSE:DATA:TELEcom:TEST:JITter:TRANSFer:MASK <jitter mask>  
                   SENSe:DATA:TELEcom:TEST:JITter:TRANSFer:MASK?

**Parameters**

<jitter mask> (discrete)	Description
GR253	GR-253 Standard mask (valid for 52 Mb/s, default for 52 Mb/s)
TYPEA	G.958 Type A equipment mask (valid for 155 and 622 Mb/s, default for 155 and 622 Mb/s)
TYPEB	G.958 Type B equipment mask (valid for 155 and 622 Mb/s)
G735	G.735 Standard mask (valid for 2 Mb/s, default for 2 Mb/s)
G751	G.751 Standard mask (valid for 34 Mb/s, default for 34 Mb/s)
UNDEFined	Undefined Standard mask (valid for 144 Mb/s, default for 144 Mb/s)

**Dependencies**    Requires installation of Option 14 jitter module.  
                           \*RST sets jitter mask to default.



<b>Errors and Events</b>	221, "Settings conflict" if the specified parameter is not correct for the current jitter receive rate.
<b>Examples</b>	Set:           SENSE:DATA:TELECOM:TEST:JITTER:TRANSFER:MASK TYPEA Query:        SENSE:DATA:TELECOM:TEST:JITTER:TRANSFER:MASK? Response:     TYPEB
<b>Related Commands</b>	None

## SENSE:DATA:TELEcom:TEST:JITter:TRANSFer:FREQuency:START

SDH/PDH Jitter/Wander Test Option Only

This command sets or queries the jitter transfer test start frequency.

**Syntax**     SENSE:DATA:TELEcom:TEST:JITter:TRANSFer:FREQuency:START  
              <tran freq start>  
              SENSE:DATA:TELEcom:TEST:JITter:TRANSFer:FREQuency:START?

Parameters	<tran freq start> (NR3-numeric)	Description
	Floating point number in range from 0 to less than end frequency	Start frequency in Hz

**Dependencies**     Requires installation of Option 14 jitter module.  
                      \*RST sets the transfer frequency start point to 10.0 Hz (default).  
                      Value must be less than end frequency.

**Errors and Events**     500, "Execution warning"  
                          if the entered value is out of range for the command.

**Examples**

```
Set:      SENSE:DATA:TELECOM:TEST:JITTER:TRANSFER:FREQUENCY
          :START 10.0

Query:    SENSE:DATA:TELECOM:TEST:JITTER:TRANSFER
          :FREQUENCY:START?

Response: 15.5
```

**Related Commands**    SENSE:DATA:TELECOM:TEST:JITTER:TRANSFER:FREQUENCY:END

## SENSe:DATA:TELEcom:TEST:JITter:TRANSFer:FREQUency:END

SDH/PDH Jitter/Wander Test Option Only

This command sets or queries the jitter transfer test end frequency.

**Syntax**

```
SENSe:DATA:TELEcom:TEST:JITter:TRANSFer:FREQUency:END
<trans freq end>
SENSe:DATA:TELEcom:TEST:JITter:TRANSFer:FREQUency:END?
```

Parameters	<tol freq end> (NR3-numeric)	Description
	Floating point number in range of greater than start frequency to 5 MHz	End frequency in Hz

**Dependencies**

- Requires installation of Option 14 jitter module.
- \*RST sets transfer frequency end to 130 KHz (default).
- Value must be greater than starting frequency.

**Errors and Events**

500, "Execution warning"  
if the entered value is out of range for the command.

**Examples**

```
Set:      SENSE:DATA:TELECOM:TEST:JITTER:TRANSFER:FREQUENCY
          :END 100000.0

Query:    SENSE:DATA:TELECOM:TEST:JITTER:TRANSFER:FREQUENCY
          :END?

Response: 130000.0
```

**Related Commands**    SENSE:DATA:TELECOM:TEST:JITTER:TRANSFER:FREQUENCY:START

**SENSe:DATA:TELeCom:TEST:JITter:TRANSFer:SAMPles**

SDH/PDH Jitter/Wander Test Option Only

This command sets or queries the number of samples, including the corner frequencies defined by the jitter transfer test mask.

**Syntax**      SENSE:DATA:TELeCom:TEST:JITter:TRANSFer:SAMPles <trans samples>  
 SENSE:DATA:TELeCom:TEST:JITter:TRANSFer:SAMPles?

Parameters	<trans samples> (NR1-numeric)	Description
	An integer in the range of 4 to 16	Number of samples including corner frequencies. Default is the number of corner frequencies.

**Dependencies**      Requires installation of Option 14 jitter module.

\*RST sets transfer samples to the default.

**Errors and Events**      500, "Execution warning"  
 if the entered value is out of range for the command.

**Examples**

Set:            SENSE:DATA:TELECOM:TEST:JITTER:TRANSFER:SAMPLES 4

Query:        SENSE:DATA:TELECOM:TEST:JITTER:TRANSFER:SAMPLES?

Response:    8

**Related Commands**      None

## SENSe:DATA:TELEcom:TEST:JITter:TRANSFer:STATE

SDH/PDH Jitter/Wander Test Option Only

This command sets or queries the action to perform when starting the jitter transfer test.

**Syntax** SENSE:DATA:TELEcom:TEST:JITter:TRANSFer:STATE <trans state>  
SENSe:DATA:TELEcom:TEST:JITter:TRANSFer:STATE?

Parameters	<trans state> (<discrete>)	Description
	TEST	Test the network element (default).
	CALibrate	Run the instrument transfer calibration routine. To determine if the instrument needs calibration,, execute SENSE:DATA:TELECOM:TEST:JITTER:TRANSFER:CALIBRATE:STATUS?

**Dependencies** Requires installation of Option 14 jitter module.  
\*RST sets transfer samples to TEST (default).  
CAL only executes if both jitter generation and measurement sources are set to LINE and the TX/RX values are set to the same rate.

**Errors and Events** 221, "Settings conflict"  
if the jitter generation source and jitter measurement source are not both LINE, or the TX/RX rates are not identical and CAL is specified.

**Examples**  
Set: SENSE:DATA:TELECOM:TEST:JITTER:TRANSFER:STATE CAL  
Query: SENSE:DATA:TELECOM:TEST:JITTER:TRANSFER:STATE?  
Response: TEST

**Related Commands** SENSe:DATA:TELEcom:TEST:JITter:TRANSfer:CALibrate:STATus?

**SENSe:DATA:TELEcom:TEST:JITter:TRANSFer:CALibrate:STATus?**

SDH/PDH Jitter/Wander Test Option Only

This command queries the jitter transfer calibration status.

**Syntax** SENSE:DATA:TELEcom:TEST:JITter:TRANSFer:CALibrate:STATus?

Parameters	<cal state> (<discrete>)	Description
	NONE	Not applicable with current instrument settings
	UNCAL	Jitter transfer is not calibrated
	RUNNING	Jitter transfer calibration in progress
	COMPLETE	Jitter transfer is calibrated

**Dependencies** Requires installation of Option 14 jitter module.

\*RST sets transfer samples to TEST (default).

CAL only executes if both jitter generation and measurement sources are set to LINE and the TX/RX values are set to the same rate.

**Errors and Events** 221, "Settings conflict"  
if the jitter generation source and jitter measurement source are not both LINE, or the TX/RX rates are not identical and CAL is specified.**Examples** Query: SENSE:DATA:TELECOM:TEST:JITTER:TRANSFER:CALIBRATE:STATUS?

Response: COMPLETE

**Related Commands** SENSE:DATA:TELEcom:TEST:JITter:TRANSfer:STATE

**SENSe:DATA:TELEcom:TEST:JITter:TRANSFer:DATA:LENGth?**

SDH/PDH Jitter/Wander Test Option Only

This query returns the actual number of measurement samples in the jitter transfer test.

**Syntax** SENSE:DATA:TELEcom:TEST:JITter:TRANSFer:DATA:LENGth?

**Response**

<data length> (discrete)	Description
An integer in the range of 1 to 16	Number of samples in the jitter transfer test. A zero means that the JITter:TRANSfer test acquired no data (the test was not run or not stopped).

**Dependencies** None

**Errors and Events** None

**Examples** Query: SENSE:DATA:TELECOM:TEST:JITTER:TRANSFER:DATA:LENGTH?  
Response: 6

**Related Commands** SENSE:DATA:TELEcom:TEST:JITter:TRANSFer:DATA?

**SENSe:DATA:TELEcom:TEST:JITter:TRANSFer:DATA?**

SDH/PDH Jitter/Wander Test Option Only

This query returns the status (frequency, amplitude, and mask values) of the specified jitter transfer test data sample. The response is a comma-separated list of values, in the order listed in the response table.

**Syntax** SENSE:DATA:TELEcom:TEST:JITter:TRANSFer:DATA? <N>

Response	<N> (NR1-numeric)	Description
	Integer in the range of 1 to 16	Data sample number
	<freq> (NR3-numeric)	Description
	Floating point number in the range of 12 $\mu$ Hz to 5 MHz	Sample frequency in Hz
	<amplitude> (NR3-numeric)	Description
	Floating point number in the range of +3 to -5	Computed jitter transfer, in dB, for frequency <freq>
	<mask> (NR3-numeric)	Description
	Floating point number in the range of +3 to -5	Mask value, in dB, for frequency <freq>
	<data status> (discrete)	Description
	NONE	Measurement data empty
	VALID	Measurement data meets mask specifications
	FAILure	Measurement data fails mask specifications
	UNLOcked	Measurement invalid due to loss of signal (LOS), jitter over range, or pattern loss

**Dependencies** None

**Errors and Events** None

**Examples**  
 Query: SENSE:DATA:TELECOM:TEST:JITTER:TRANSFER:DATA? 1  
 Response: 1, 500.0, -2.3, -5.0, VALID

**Related Commands** SENSE:DATA:TELECOM:TEST:JITTER:TRANSFER:DATA:LENGTH?

## SENSe:DATA:TELecom:TEST:JITter:TRANSFer:ALLData?

SDH/PDH Jitter/Wander Test Option Only

This query returns the complete status (frequency, amplitude, and mask values) of the jitter transfer test data samples. The response is a comma-separated list of values, in the order listed in the response table.

**Syntax** SENSe:DATA:TELecom:TEST:JITter:TRANSFer:ALLData

**Response**

<N> (NR1-numeric)	Description
<x1-freq>	Frequency (Hz) of point 1
<x1-ampl>	Amplitude (UI) of point 1
<x1-mask>	Mask amplitude (UI) of point 1
<x1-status>	Data status of point 1
...	...
<xn-freq>	Frequency (Hz) of point n
<xn-ampl>	Amplitude (UI) of point n
<xn-mask>	Mask amplitude (UI) of point n
<xn-status>	Data status of point n

Where n is the number of points returned by the SENSe:DATA:TELecom:TEST:JITter:TRANSFer:DATA:LENGth? command

<freq> (NR3-numeric)	Description
Floating point number in the range of 12 $\mu$ Hz to 5 MHz	Sample frequency in Hz

<amplitude> (NR3-numeric)	Description
Floating point number in the range of +3 to -5	Computed jitter transfer, in dB, for frequency <freq>

<mask> (NR3-numeric)	Description
Floating point number in the range of +3 to -5	Mask value, in dB, for frequency <freq>



<data status> (discrete)	Description
NONE	No measurement data
VALID	Measurement data valid
FAILure	Measurement data failed (data greater than mask)
UNLOcked	Measurement invalid due to loss of signal (LOS) or jitter over range

**Dependencies** None

**Errors and Events** None

**Examples**  
 Query: SENSE:DATA:TELECOM:TEST:JITTER:TRANSFER:ALLDATA?  
 Response: 20,1.2,1.8,VALID,100,-2.0,6.0,VALID,100.E+1,-3.0,6.0,VALID,100.E+3,0.0,10.0,LOS

**Related Commands** SENSE:DATA:TELEcom:TEST:JITter:TRANSFer:DATA?

## SENSe:DATA:TELEcom:TEST:JITter:OUTPUT:DURation

SDH/PDH Jitter/Wander Test Option Only

This command sets or queries the length of the output jitter test.

**Syntax** SENSE:DATA:TELEcom:TEST:JITter:OUTPUT:DURation <tmin>, <tsec>  
 SENSE:DATA:TELEcom:TEST:JITter:OUTPUT:DURation?

Parameters	<tmin> (NR1-numeric)	Description
	Integer in the range of 0 to 15 (default is 1)	Output jitter test time, in minutes
Parameters	<tsec> (NR1-numeric)	Description
	Integer in the range of 0 to 59 (default is 0)	Output jitter test time, in seconds

**Dependencies** Requires installation of Option 14 jitter module.  
 \*RST sets the test duration to 1 minute, zero seconds  
 The maximum output jitter test duration is 15 minutes, zero seconds

**Errors and Events** 500, "Execution warning"  
 if the entered value is out of range for the command.

**Examples** Set: SENSE:DATA:TELECOM:TEST:JITTER:OUTPUT:DURATION 1,0  
 Query: SENSE:DATA:TELECOM:TEST:JITTER:OUTPUT:DURATION?  
 Response: 2,5

**Related Commands** None

## SENSe:DATA:TELEcom:TEST:JITter:OUTPUT:INFOrmation?

SDH/PDH Jitter/Wander Test Option Only

This query returns the settings of the output jitter test.

**Syntax** SENSe:DATA:TELEcom:TEST:JITter:OUTPUT:INFOrmation:<info>?

**Parameters**

<info> (discrete)	Description
SOURce	Results source
TIME	Test start time
DATE	Test start date
RXSource	Received signal source
RXRate	Received signal rate

**Response**

SOURce	Description
NONE	Results not available
MEMory	Results read from instrument memory
DISK	Results read from disk

*(continued on next page)*

<b>TIME</b>	<b>Description</b>
HH:MM:SS	Test start time (hr, min, sec)

<b>DATE</b>	<b>Description</b>
YY:MM:DD	Test start date (yr, mo, day)

<b>RXSource</b>	<b>Description</b>
LINE	Receive measurement source is line
CLOCK	Receive measurement source is clock

<b>RXRate</b>	<b>Description</b>
M52	52 Mb/s (STM-0)
M155	155 Mb/s (STM-1)
M622	622 Mb/s (STM-4)
M2	2 Mb/s
M34	34 Mb/s
M140	140 Mb/s

**Dependencies** None

**Errors and Events** None

**Examples** Query: SENSE:DATA:TELECOM:TEST:JITTER:OUTPUT:INFORMATION:RXS?  
Response: CLOCK

**Related Commands** None

## SENSe:DATA:TELEcom:TEST:JITter:OUTPUT:HIGHBand:DATA?

SDH/PDH Jitter/Wander Test Option Only

This query returns the maximum peak-to-peak jitter amplitude, the maximum jitter allowed value, and the highband filter output compliance test status.

**Syntax** SENSE:DATA:TELEcom:TEST:JITter:OUTPUT:HIGHBand:DATA?

**Response**

<output data>, <output max>, <output stat>	Description
<output data>	Description
Floating point number in the range of 0 to 200	Peak-to-peak jitter, in UI
<output max>	Description
Floating point number	Maximum allowed jitter for the selected standard
<output stat>	Description
NONE	No measurement data
VALID	Measurement data valid
LOSignal	Measurement data invalid due to LOS
UNLOcked	Measurement data invalid due to jitter over range

**Dependencies** None

**Errors and Events** None

**Examples**  
 Query: SENSE:DATA:TELECOM:TEST:JITTER:OUTPUT:HIGHBAND:DATA?  
 Response: 12.6, 4.1, VALID

**Related Commands** None

**SENSe:DATA:TELEcom:TEST:JITter:OUTPUT:WIDEband:DATA?**

SDH/PDH Jitter/Wander Test Option Only

This query returns the maximum peak-to-peak jitter amplitude, the maximum jitter allowed value, and the wideband filter output compliance test status.

**Syntax**      SENSE:DATA:TELEcom:TEST:JITter:OUTPUT:WIDEband:DATA?

**Response**

<output data>	Description
Floating point number in the range of 0 to 200	Peak-to-peak jitter, in UI

<output max>	Description
Floating point number	Maximum allowed jitter for the selected standard

<output stat>	Description
NONE	No measurement data
VALID	Measurement data valid
LOSignal	Measurement data invalid due to LOS
UNLOCKed	Measurement data invalid due to jitter over range

**Dependencies**      None

**Errors and Events**      None

**Examples**      Query:      SENSE:DATA:TELECOM:TEST:JITTER:OUTPUT:WIDEBAND:DATA?

Response: 12.6, 4.1, VALID

**Related Commands**      None

## SENSe:DATA:TELEcom:TEST:JITter:POINter:INFORmation?

SDH/PDH Jitter/Wander Test Option Only

This query returns jitter pointer test settings.

**Syntax** SENSe:DATA:TELEcom:TEST:JITter:POINter:INFORmation:<info>?

**Parameters**

<info> (discrete)	Description
SOURce	Results source
TIME	Test start time
DATE	Test start date
TXRate	Transmitted signal rate
RXRate	Received signal rate
MODE	Normal or custom mode
PTRType	Pointer type
SEQType	Sequence type
PTRDir	Pointer direction
PTRRate	Pointer rate

**Response**

SOURce	Description
NONE	Results not available
MEMory	Results read from instrument memory
DISK	Results read from disk

TIME	Description
HH:MM:SS	Test start time (hr, min, sec)

DATE	Description
YY:MM:DD	Test start date (yr, mo, day)

<b>TXRate</b>	<b>Description</b>
M52	52 Mb/s (STM-0)
M155	155 Mb/s (STM-1)
M622	622 Mb/s (STM-4)

<b>RXRate</b>	<b>Description</b>
M2	2 Mb/s (E1)
M34	34 Mb/s (E3)
M140	140 Mb/s (E4)
M52	52 Mb/s (STM-0)
M155	155 Mb/s (STM-1)
M622	622 Mb/s (STM-4)

<b>MODE</b>	<b>Description</b>
NORMal	Default sequence selections
CUSTom	Custom sequence selections

<b>PTRType</b>	<b>Description</b>
AU	AU pointer
TU	TU pointer

<b>SEQType</b>	<b>Description</b>
SINGle	Single pointer adjustment
BURSt	Burst pointer adjustment
PHASE	Phase transient pointer adjustment
P873	Periodic 87-3 pointer adjustment
P873CAN	Periodic 87-3 with cancel pointer adjustment
P873ADD	Periodic 87-3 with add pointer adjustment
P351	Periodic 35-1 pointer adjustment (TU-12 only)
P351CAN	Periodic 35-1 with cancel pointer adjustment (TU-12 only)
P351ADD	Periodic 35-1 with add pointer adjustment (TU-12 only)
P855	Periodic 85-5 pointer adjustment (TU-3 only)
P855CAN	Periodic 85-5 with cancel pointer adjustment (TU-3 only)

P855ADD	Periodic 85-5 with add pointer adjustment (TU-3 only)
PCONtinuous	Periodic continuous pointer adjustment
PCONCAN	Periodic continuous with cancel pointer adjustment
PCONADD	Periodic continuous with add pointer adjustment
REGDBL	Regular pointer plus one double
REGMIS	Regular pointer with one missing
SINALT	Single alternating pointer adjustment
DBLALT	Double alternating pointer adjustment
CUSTOM	Use the transmitter pointer sequence setup

PTRDir	Description
UP	Increment
DOWN	Decrement

PTRRate (NR1-numeric)	Description
Integer in the range of 2 to 10000	Pointer rate in ms

**Dependencies** None

**Errors and Events** None

**Examples** Query: SENSE:DATA:TELECOM:TEST:JITTER:POINTER:  
INFORMATION:MODE?  
Response: CUSTOM

**Related Commands** None



**SENSe:DATA:TELEcom:TEST:JITter:POINter:SEQuence:TYPE**

SDH/PDH Jitter/Wander Test Option Only

This command sets or queries the pointer sequence type for the jitter pointer test.

**Syntax** SENSE:DATA:TELEcom:TEST:JITter:POINter:SEQuence:TYPE  
 <ptr seq type>  
 SENSE:DATA:TELEcom:TEST:JITter:POINter:SEQuence:TYPE?

**Parameters**

<ptr seq type> (discrete)	Description
SINGLE	Single pointer adjustment (G.783 e)
BURSt	Burst pointer adjustment (G.783 f)
PHASE	Phase transient pointer adjustment
P873	Periodic 87-3 pointer adjustment (G.783 g1)
P873CAN	Periodic 87-3 with cancel pointer adjustment (G.783 g3)
P873ADD	Periodic 87-3 with add pointer adjustment (G.783 g2)
PCONtinuous	Periodic continuous pointer adjustment (G.783 h1)
PCONCAN	Periodic continuous with cancel pointer adjustment (G.783 h3)
PCONADD	Periodic continuous with add pointer adjustment (G.783 h2)
REGDBL	Regular pointer plus one double (G.783 b)
REGMIS	Regular pointer with one missing (G.783 c)
SINALT	Single alternating pointer adjustment
SINALT	Single alternating pointer adjustment (G.783 a)
DBLALT	Double alternating pointer adjustment (G.783 d)
CUSTom	Use the transmitter pointer sequence setup

**Dependencies** Requires installation of Option 14 jitter module.  
 Pointer test must not be running. Setting this parameter during a pointer test returns an error.

**Errors and Events** None

**Examples**  
 Set: SENSE:DATA:TELECOM:TEST:JITTER:POINTER:SEQUENCE  
 :TYPE BURST  
 Query: SENSE:DATA:TELECOM:TEST:JITTER:POINTER:SEQUENCE  
 :TYPE?  
 Response: P873ADD

**Related Commands** None

## SENSe:DATA:TELEcom:TEST:JITter:POINter:HIGHBand:DATA?

SDH/PDH Jitter/Wander Test Option Only

This query returns the maximum peak-to-peak jitter amplitude, the maximum jitter allowed value, and the highband filter pointer compliance test status.

**Syntax** SENSe:DATA:TELEcom:TEST:JITter:POINter:HIGHBand:DATA?

Response	<output data>	Description
		Floating point number in the range of 0 to 200
	<output max>	Description
		Floating point number

*(continued on next page)*

<output stat>	Description
NONE	No measurement data
VALID	Measurement data valid
LOSignal	Measurement data invalid due to LOS
UNLOcked	Measurement data invalid due to jitter over range

**Dependencies** None

**Errors and Events** None

**Examples** Query: SENSE:DATA:TELECOM:TEST:JITTER:POINTER:HIGHBAND:DATA?  
Response: 1.2, 2.0, VALID

**Related Commands** SENSE:DATA:TELEcom:TEST:JITter:POINter?

## SENSe:DATA:TELEcom:TEST:JITter:POINter:WIDEband:DATA?

SDH/PDH Jitter/Wander Test Option Only

This query returns the maximum peak-to-peak jitter amplitude, the maximum jitter allowed value, and the wideband filter pointer compliance test status.

**Syntax** SENSE:DATA:TELEcom:TEST:JITter:POINter:WIDEband:DATA?

**Response**

<output data>	Description
Floating point number in the range of 0 to 200	Peak-to-peak jitter, in UI

<output max>	Description
Floating point number	Maximum allowed jitter for the selected standard

(continued on next page)

<output stat>	Description
NONE	No measurement data
VALID	Measurement data valid
LOSignal	Measurement data invalid due to LOS
UNLOcked	Measurement data invalid due to jitter over range

**Dependencies**      None

**Errors and Events**      None

**Examples**      Query:      SENSE:DATA:TELECOM:TEST:JITTER:POINTER:WIDEBAND:DATA?  
 Response: 1,2, 2.0, VALID

**Related Commands**      SENSE:DATA:TELEcom:TEST:JITter:POINter?

## SENSe:DATA:TELEcom:OVERhead and POVerhead Subsystem

This section describes each of the commands and queries used to analyze the transport overhead and path overhead. Figure 2–28 shows the hierarchy tree for this subsystem.

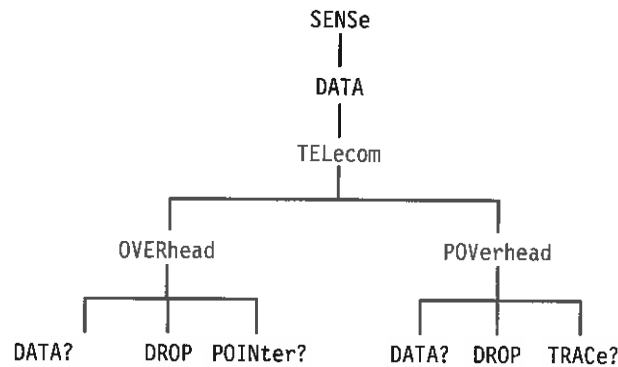

Figure 2–28: SENSE:DATA:TELEcom:OVERhead and POVerhead subsystem

### SENSe:DATA:TELEcom:OVERhead:DATA?

This query returns the value in the transport overhead byte of the specified channel. See Figure 2–14 on page 2–32 for the definition of offset values.

**Syntax** SENSE:DATA:TELEcom:OVERhead:DATA? <channel>,<byte>,<offset>

Parameters	<channel> (NR1-numeric)	Description
	1	Rate is STM-1
	1 to 4	Rate is STM-4

<byte> (discrete)	Description
A1, A2, B1, B2, H1, H2, H3, C1, D1, F1, D1, D2, D3, K1, K2, D4, D5, D6, D7, D8, D9, D10, D11, D12, S1, M1, E2	Only the bytes listed return a valid response

<offset> (NR1-numeric)	Description
0 to 2	Any SDH rate

Response	<value> (NR1-numeric)	Description
	Any number in the range 0 to 255	The byte is set to this value
	-1	No signal received

**Dependencies** None

**Errors and Events** 221, "Settings conflict; Channel is out of range"

**Examples**  
 Query: SENSE:DATA:TELECOM:OVERHEAD:DATA? 1,C1,0  
 Response: 123

**Related Commands** INITiate  
 TRIGger:IMMediate

## SENSe:DATA:TELEcom:OVERhead:DROP

This command sets or queries the transport overhead bytes to be dropped to an external protocol analyzer.

**Syntax** SENSE:DATA:TELEcom:OVERhead:DROP <dropped overhead>  
 SENSE:DATA:TELEcom:OVERhead:DROP?

Parameters	<dropped overhead> (discrete)	Description
	NONE	No overhead bytes dropped (default)
	SDCC	Regenerator section DCC
	LDCC	Multiplexer section DCC
	F1	F1 User Byte

**Dependencies** You can drop the transport overhead or the path overhead by using the SENSE:DATA:TELEcom:OVERhead:DROP and SENSE:DATA:TELEcom:POVerhead:DROP commands. The last command sent applies.

**Errors and Events** None

**Examples**

Set: SENSE:DATA:TELECOM:OVERHEAD:DROP SDCC

Query: SENSE:DATA:TELECOM:OVERHEAD:DROP?

Response: SDCC

**Related Commands** None

## SENSe:DATA:TELecom:OVERhead:POINter?

This query returns the current value of the H1 and H2 overhead bytes of the active channel. If the instrument is receiving a LOS, LOF, or LOP, the last valid pointer value will be returned.

**Syntax** SENSe:DATA:TELecom:OVERhead:POINter?

Response	<pointer value> (NR1-numeric)	Description
	Any integer in the range 0 to 1023	H1 and H2 are set to this value

**Dependencies** You must have a test running for a valid pointer value to be returned (use the SENSe:DATA:TELecom:TEST:STARt command to start a test).

**Errors and Events** None

**Examples**

Query: SENSE:DATA:TELECOM:OVERHEAD:POINTER?

Response: 123

**Related Commands**

SENSe:DATA:TELecom:OVERhead:DATA?

SENSe:DATA:TELecom:TEST:STARt

## SENSe:DATA:TELEcom:POVerhead:DATA?

This query returns the value in the specified path overhead byte.

**Syntax** SENSE:DATA:TELEcom:POVerhead:DATA? <byte>

Parameters	<byte> (discrete)	Description
		J1, B3, C2, G1, F2, H4, F3, K3, N1

Response	<value> (NR1-numeric)	Description
		Any number in the range 0 to 255

**Dependencies** Use the SENSE:DATA:TELEcom:CHANNEL command to specify which path trace to query.

**Errors and Events** None

**Examples**  
 Query: SENSE:DATA:TELECOM:POVERHEAD:DATA? C2  
 Response: 123

**Related Commands**  
 INITiate  
 TRIGger:IMMediate



## SENSe:DATA:TELEcom:POVerhead:DROP

This command sets or queries the path overhead channels to be dropped to an external protocol analyzer.

**Syntax** SENSE:DATA:TELEcom:POVerhead:DROP <dropped overhead>  
SENSe:DATA:TELEcom:POVerhead:DROP?

### Parameters

<dropped overhead> (discrete)	Description
NONE	Nothing is dropped (default)
F2	F2 User Byte

### Dependencies

You can drop the transport overhead or the path overhead by using the SENSE:DATA:TELEcom:OVERhead:DROP and SENSE:DATA:TELEcom:POVerhead:DROP commands. The last command sent applies.

### Errors and Events

None

### Examples

Set: SENSE:DATA:TELECOM:POVERHEAD:DROP F2

Query: SENSE:DATA:TELECOM:POVERHEAD:DROP?

Response: F2

### Related Commands

None

## SENSe:DATA:TELeom:POVerhead:TRACe?

This query returns the current path trace string that repeats in the J1 byte as a repeating byte sequence. The response is created in the following way: the first character after a null is read as the first byte and is followed by 63 J1 bytes from consecutive frames.

**Syntax**      SENSe:DATA:TELeom:POVerhead:TRACe?

Response	<path trace> (string)	Description
	Length is a maximum of 64 bytes; if length is less than 64 bytes, the buffer is padded with nulls	The J1 byte is set to this value

**Dependencies**      The SENSe:DATA:TELeom:CHANnel command specifies which path trace to query.

**Errors and Events**      None

**Examples**      Query:      SENSe:DATA:TELeom:POVerhead:TRACe?  
 Response: "THIS IS THE FIRST RUN OF TEST ABC"

**Related Commands**      SENSe:DATA:TELeom:POVerhead:DATA?  
 INITiate  
 TRIGger:IMMediate

## SENSe:DATA:TELEcom:MEASure Subsystem

This section describes the commands and queries that access error, alarm, failure, and pointer measurements for current and previous tests. Figures 2–29 through 2–33 show the hierarchy trees for this subsystem.

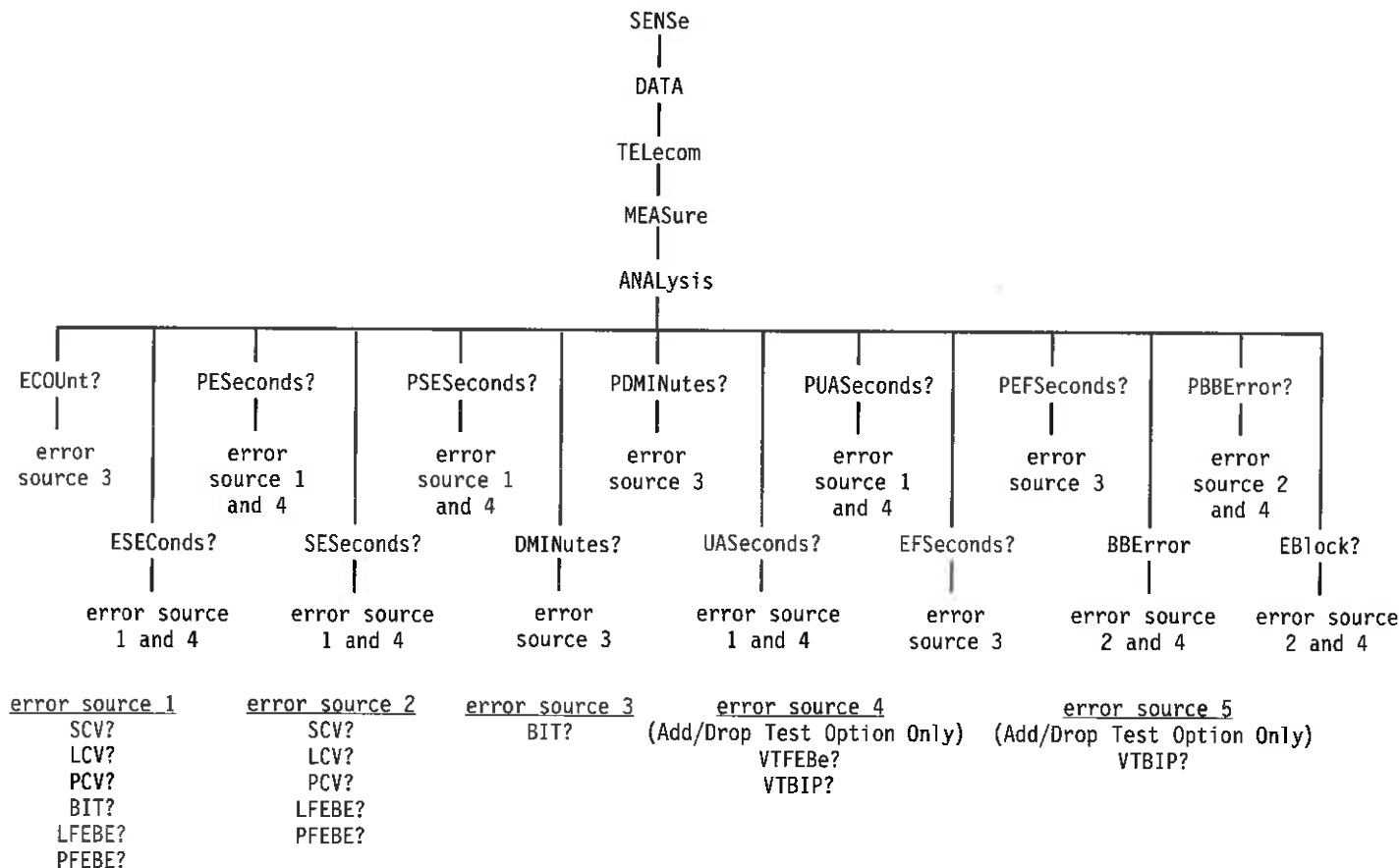

Figure 2–29: SENSE:DATA:TELEcom:MEASure:ANALysis subsystem (SDH)

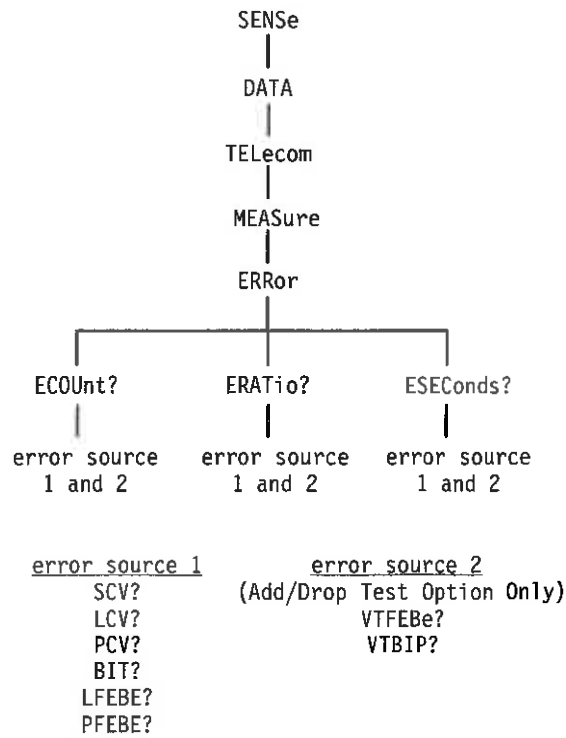

Figure 2-30: SENSE:DATA:TELEcom:MEASure:ERRor subsystem

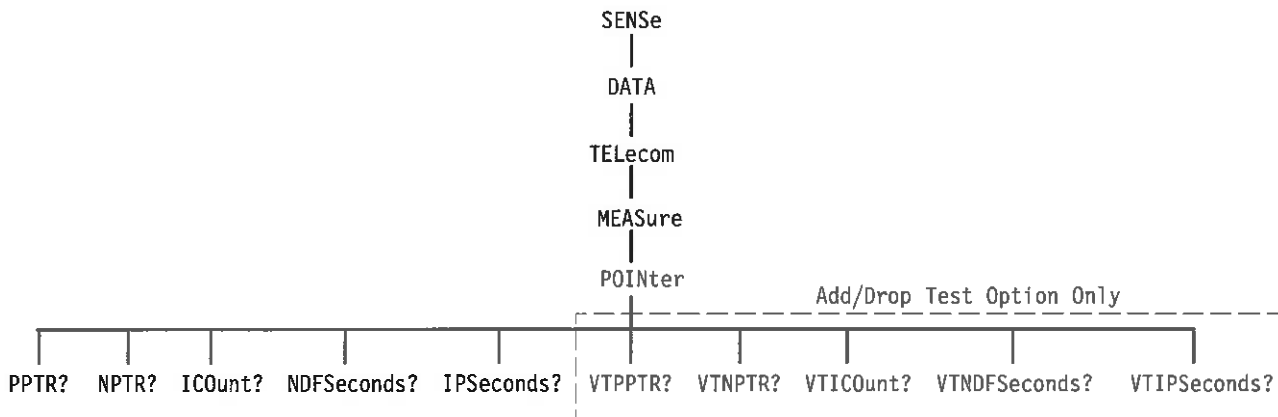
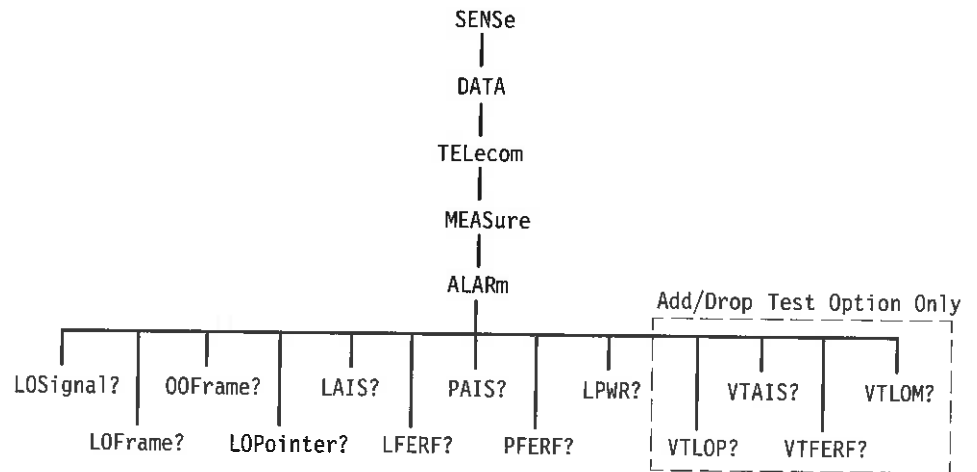
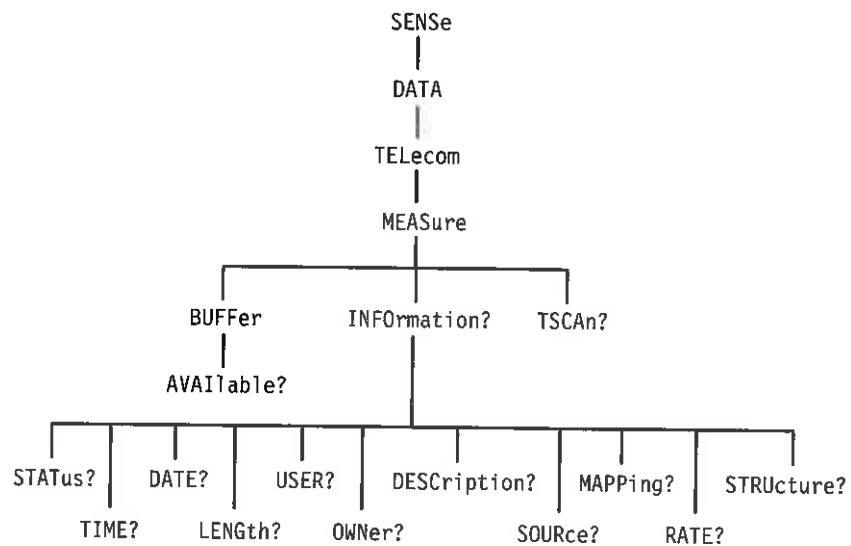

Figure 2-31: SENSE:DATA:TELEcom:MEASure:POINter subsystem



**Figure 2-32: SENSE:DATA:TELEcom:MEASure:ALARm subsystem**



**Figure 2-33: SENSE:DATA:TELEcom:MEASure:BUFFer and INFOrmation subsystems**

A variety of error, alarm, failure, and pointer measurements are reported through this subsystem. Table 2-7 shows how error, alarm, and failure measurements are calculated. Tables 2-8 and 2-9 show how the analysis measurements are calculated. These calculations are based on CCITT G.821 specifications.

**Table 2–7: How error, alarm, and pointer measurements are calculated**

Type of measurement	Method of calculation
Error count	Number of bit errors that were errored in the signal
Bit Error Ratio (BER)	Ratio of error count to the total number of received bits
Errored seconds	Number of seconds that had any error counts or failures such as Loss of Signal (LOS) or Severely Errored Frame (SEF)
Pointer measurements	Number of events that occur in the H1 and H2 pointer bytes
New Data Flag Seconds	Number of one-second intervals that contain new data flags
Illegal Pointer Seconds	Number of one-second intervals that contain illegal pointers
Positive Pointer Justifications	Number of times the pointer value is incremented
Negative Pointer Justifications	Number of times the pointer value is decremented
Alarms	Number of one-second intervals that contained a specific alarm such as Loss of Signal (LOS), Loss of Pointer (LOP), and Path Alarm Indication Signal (PAIS)

**Table 2–8: How analysis measurements are calculated**

Type of measurement	Method of calculation
Error count	Number of bit errors not occurring during periods of unavailability (see Unavailable seconds)
Errored seconds	Total number of severely errored seconds not occurring during a period of unavailability (see Unavailable seconds)
Severely errored seconds	Number of seconds with more than N errors (see Table 2–9)
Severely errored framing seconds	Number of seconds where the incoming signal could not be framed (applies only to the Section layer)
Unavailable seconds	Number of seconds that the signal had too many errors to be available for use; unavailability starts at the onset of ten contiguous severely errored seconds
Error free seconds	Number of seconds that contained zero errors

**Table 2-9: Value of N for analysis measurements**

Rate	N (Section B1 Errors)	N (Line B2 Errors)
STM-1	2500	2500
STM-4	8800	10000

Some of the queries in this section have their information presented in a way that is different from queries in the rest of the manual. The syntax and examples are in table format. Figure 2-34 shows you how to read the Syntax Tables in this section. Follow the step numbers to create any query. Table 2-10 explains the acronyms used in the SENSE:DATA:TELEcom:MEASure Syntax Tables.

1 Start with the syntax statement listed under Syntax.

3 Add a question mark or one of these items (remember to keep the colon in front of this item).

2 Add one of these items to the end of the syntax statement.

**Table X-X: Syntax Table for SENSE:DATA:TELEcom:MEASure:ERROR Queries**

Select a measurement from the left column	Then select an error source from the top row						
	?	:SCV?	:LCV?	:PCV?	:BIT?	:LFEBE?	:PFEBE?
ECOUNt	error count	error count	error count	error count	error count	error count	error count
ERATio	bit error ratio	bit error ratio	bit error ratio	bit error ratio	bit error ratio	bit error ratio	bit error ratio
ESEconds	errored seconds	errored seconds	errored seconds	errored seconds	errored seconds	errored seconds	errored seconds

All error counts and errored seconds return NR1-numeric responses.  
All bit error ratios return NR3-numeric responses.

4 The response type is listed in the footnote.

5 The response description for each combination of items is listed in each cell of the table. If no query exists for a particular combination of items, "no query" is listed in the cell.

**Figure 2-34: How to read the syntax tables in the SENSE:DATA:TELEcom:MEASure subsystem section**

**Table 2–10: Acronyms used in the SENSE:DATA:TELEcom:MEASure queries**

Acronym	Meaning
SCV	Section/RS Code Violation
LCV	Line/MS Code Violation
PCV	Path Code Violation
BIT error (not an acronym)	Pattern bit error
LFEBE	Line/MS Far End Block Error
PFEBE	Path Far End Block Error
VTBIP	TU BIP (Add/Drop Test Option Only)
VTFEBE	TU FEBE (Add/Drop Test Option Only)

Figure 2–35 shows you how to read the Example Tables in this section.

**Table X–X: Example Table for SENSE:DATA:TELEcom:MEASure:ERRor Queries**

Query	Response
SENSE:DATA:TELECOM:MEASURE:ERROR:ECOUNT:SCV?	60904
SENSE:DATA:TELECOM:MEASURE:ERROR:ERATIO:PCV?	9.23E-6
SENSE:DATA:TELECOM:MEASURE:ERROR:ESECONDS:PFEBE?	6

Selected examples of queries are shown in the left column

A typical response is shown in the right column for each example

**Figure 2–35: How to read the example tables in the SENSE:DATA:TELEcom:MEASure subsystem section**

## SENSe:DATA:TELEcom:MEASure:ERRor Queries

These queries return error measurements. When you use the high-level queries (for example, SENSE:DATA:TELEcom:MEASure:ERRor? or SENSE:DATA:TELEcom:MEASure:ERRor:ECOUNT?), it is helpful to turn the headers on (SYSTem:HEADers ON) so you can identify each response value in the response string.

**Syntax** SENSE:DATA:TELEcom:MEASure:ERRor?

SENSe:DATA:TELEcom:MEASure:ERRor: [measurement]: [error source]  
(see Tables 2–11 and 2–12 to complete the query)



Table 2–11: Syntax table for SENSE:DATA:TELEcom:MEASure:ERRor queries

Select a measurement from the left column	Then select an error source from the top row						
	?	:SCV?	:LCV?	:PCV?	:BIT?	:LFEBE?	:PFEBE?
ECOUNT	all error counts	error count	error count	error count	error count	error count	error count
ERATIO	all bit error ratios	bit error ratio	bit error ratio	bit error ratio	bit error ratio	bit error ratio	bit error ratio
ESECONDS	all errored seconds	errored seconds	errored seconds	errored seconds	errored seconds	errored seconds	errored seconds

All errored seconds return NR1-numeric responses.

All error counts and error bit ratios return NR3-numeric responses.

Table 2–12: Syntax table for SENSE:DATA:TELEcom:MEASure:ERRor queries (Add/Drop Test Option Only)

Select a measurement from the left column	Then select an error source from the top row	
	:VTFEBe?	:VTBIP?
ECOUNT:	error count	error count
ERATIO	bit error ratio	bit error ratio
ESECONDS	errored seconds	errored seconds

All error counts and errored seconds return NR1-numeric responses.

All bit error ratios return NR3-numeric responses.

**Response** See Tables 2–11 and 2–12.

**Dependencies** These measurement queries can be sent at any time. But, if a test is currently running, the responses to the queries might not represent the final error measurements. After a test has been stopped or the test duration has expired, you can send these measurement queries again to get the final error measurements.

**Errors and Events** None

**Examples** See Table 2–13.

**Table 2–13: Example table for SENSE:DATA:TELEcom:MEASure:ERRor queries**

Query	Response
SENSE:DATA:TELECOM:MEASURE:ERROR:ECOUNT:SCV?	60904
SENSE:DATA:TELECOM:MEASURE:ERROR:ERATIO:PCV?	9.23E-6
SENSE:DATA:TELECOM:MEASURE:ERROR:ESECONDS:PFEBE?	6

**Related Commands** SENSE:DATA:TELEcom:TEST:START  
SENSE:DATA:TELEcom:TEST:STOP

## SENSE:DATA:TELEcom:MEASure:ANALysis Queries

These queries return an analysis of section, line, path, and payload errors. When you use the high-level queries (for example, SENSE:DATA:TELEcom:MEASure:ANALysis? or SENSE:DATA:TELEcom:MEASure:ANALysis:ECOUnt?), it is helpful to turn the headers on (SYSTem:HEADers ON) so you can identify each response value in the response string.

**Syntax** SENSE:DATA:TELEcom:MEASure:ANALysis?

SENSE:DATA:TELEcom:MEASure:ANALysis:[measurement]:[error source]  
(see Tables 2–14 and 2–15 to complete the query)

**Table 2–14: Syntax table for SENSE:DATA:TELEcom:MEASure:ANALysis queries**

Select a measurement from the left column	Then select an error source from the top row						
	?	:SCV?	:LCV?	:PCV?	:BIT?	:LFEBE?	:PFEBE?
<b>ECOUnt</b>	all error counts	no query	no query	no query	all error counts	no query	no query
<b>ESEConds</b>	all errored seconds	errored seconds	errored seconds	errored seconds	errored seconds	errored seconds	errored seconds
<b>PESeconds</b>	all ratio errored seconds	ratio errored seconds	ratio errored seconds	ratio errored seconds	percent errored seconds	ratio errored seconds	ratio errored seconds
<b>SESeconds</b>	all severely errored seconds	severely errored seconds	severely errored seconds	severely errored seconds	severely errored seconds	severely errored seconds	severely errored seconds

Table 2-14: Syntax table for SENSE:DATA:TELEcom:MEASure:ANALysis queries (Cont.)

Select a measurement from the left column	Then select an error source from the top row						
	?	:SCV?	:LCV?	:PCV?	:BIT?	:LFEBE?	:PFEBE?
PSESeconds	all ratio severely errored seconds	ratio severely errored seconds	ratio severely errored seconds	ratio severely errored seconds	percent severely errored seconds	ratio severely errored seconds	ratio severely errored seconds
UASeconds	all unavailable seconds	unavailable seconds	unavailable seconds	unavailable seconds	unavailable seconds	unavailable seconds	unavailable seconds
PUASeconds	all ratio unavailable seconds	ratio unavailable seconds	ratio unavailable seconds	ratio unavailable seconds	percent unavailable seconds	ratio unavailable seconds	ratio unavailable seconds
EFSeconds	all error free seconds	no query	no query	no query	error free seconds	no query	no query
PEFSeconds	all percent error free seconds	no query	no query	no query	percent error free seconds	no query	no query
DMINutes	all degraded minutes	no query	no query	no query	degraded minutes	no query	no query
PDMINutes	all percent degraded minutes	no query	no query	no query	percent degraded minutes	no query	no query
EBlock	all block errors	block errors	block errors	block errors	no query	block errors	block errors
BBError	all background block errors	background block errors	background block errors	background block errors	no query	background block errors	background block errors
PBBError	all ratio background block errors	ratio background block errors	ratio background block errors	ratio background block errors	no query	ratio background block errors	ratio background block errors

All percent measurements return NR3-numeric responses.

All other measurements return NR1-numeric responses.

Table 2-15: Syntax table for SENSE:DATA:TELEcom:MEASure:ANALysis queries (SDH and Add/Drop Test Option Only)

Select a measurement from the left column	Then select an error source from the top row	
	:VTFEBe?	:VTBIP?
ESECONDS	errored seconds	errored seconds
PESeconds	ratio errored seconds	ratio errored seconds
EBlock	block errors	block errors
BBError	background block errors	background block errors

**Table 2–15: Syntax table for SENSE:DATA:TELEcom:MEASure:ANALysis queries (SDH and Add/Drop Test Option Only) (Cont.)**

Select a measurement from the left column	Then select an error source from the top row	
	:VTFEBE?	:VTBIP?
PBBError	ratio background block errors	ratio background block errors
SESeconds	severely errored seconds	severely errored seconds
PSESeconds	ratio severely errored seconds	ratio severely errored seconds
UASeconds	unavailable seconds	unavailable seconds
PUASeconds	ratio unavailable seconds	ratio unavailable seconds

All bit error ratios and percent measurements return NR3-numeric responses.

All other measurements return NR1-numeric responses.

**Response** See Tables 2–14 and 2–15.

**Dependencies** These measurement queries can be sent at any time. However, if a test is currently running, the responses to the queries might not represent the final error measurements. After a test has been stopped or the test duration has expired, you can send these measurement queries again to get the final error measurements.

**Errors and Events** None

**Examples** See Table 2–16.

**Table 2–16: Example table for SENSE:DATA:TELEcom:MEASure:ANALysis queries (SDH)**

Query	Response
SENSE:DATA:TELECOM:MEASURE:ANALYSIS:SECONDS:LCV?	23
SENSE:DATA:TELECOM:MEASURE:ANALYSIS:BBERROR:SCV?	103
SENSE:DATA:TELECOM:MEASURE:ANALYSIS:PUASECONDS:LFEBE?	1.2E-1

**Related Commands** SENSE:DATA:TELEcom:TEST:START  
SENSE:DATA:TELEcom:TEST:STOP

## SENSe:DATA:TELeCom:MEASure:ALARm Queries

These queries return alarm measurements. When you use the SENSe:DATA:TELeCom:MEASure:ALARm? query, it is helpful to turn the headers on (SYSTem:HEADers ON) so you can identify each response value in the response string.

**Syntax** All valid queries are listed in the Syntax column of Tables 2–17 and 2–18.

**Table 2–17: Syntax table for SENSe:DATA:TELeCom:MEASure:ALARm queries**

Syntax	Response
SENSe:DATA:TELeCom:MEASure:ALARm?	All alarm measurements
SENSe:DATA:TELeCom:MEASure:ALARm:LOSignal?	Number of seconds of Loss of Signal
SENSe:DATA:TELeCom:MEASure:ALARm:LOFrame?	Number of seconds of Loss of Frame
SENSe:DATA:TELeCom:MEASure:ALARm:OOFrame?	Number of seconds of Out of Frame
SENSe:DATA:TELeCom:MEASure:ALARm:LOPointer?	Number of seconds of Loss of Pointer
SENSe:DATA:TELeCom:MEASure:ALARm:LAIS?	Number of seconds of MS AIS
SENSe:DATA:TELeCom:MEASure:ALARm:LFERf?	Number of seconds of MS FERF
SENSe:DATA:TELeCom:MEASure:ALARm:PFERf?	Number of seconds of Path FERF
SENSe:DATA:TELeCom:MEASure:ALARm:PAIS?	Number of seconds of Path AIS
SENSe:DATA:TELeCom:MEASure:ALARm:LPWR?	Number of seconds of instrument power loss during a test

All responses are in NR3-numeric format.

**Table 2–18: Syntax table for SENSe:DATA:TELeCom:MEASure:ALARm queries (Add/Drop Test Option Only)**

Syntax	Response
SENSe:DATA:TELeCom:MEASure:ALARm:VTLOP?	Number of seconds of tributary Loss of Pointer
SENSe:DATA:TELeCom:MEASure:ALARm:VTAIS?	Number of seconds of tributary AIS
SENSe:DATA:TELeCom:MEASure:ALARm:VTFERf?	Number of seconds of tributary FERF
SENSe:DATA:TELeCom:MEASure:ALARm:VTLOM?	Number of seconds of tributary Loss of Multiframe

All responses are in NR3-numeric format.

**Response** See the Response column of Tables 2–17 and 2–18.

**Dependencies** These measurement queries can be sent at any time. However, if a test is currently running, the responses to the queries might not represent the final error measurements. After a test has been stopped or the test duration has expired, you can send these measurement queries again to get the final error measurements.

**Errors and Events** None

**Examples** See Table 2–19.

**Table 2–19: Example table for SENSE:DATA:TELEcom:MEASure:ALARm queries**

Query	Response
SENSE:DATA:TELECOM:MEASURE:ALARM:LOPOINTER?	20
SENSE:DATA:TELECOM:MEASURE:ALARM:OOFAME?	13

**Related Commands** SENSE:DATA:TELEcom:TEST:START  
SENSE:DATA:TELEcom:TEST:STOP

## SENSE:DATA:TELEcom:MEASure:POINter Queries

These queries return pointer-related measurements. When you use the SENSE:DATA:TELEcom:MEASure:POINter? query, it is helpful to turn the headers on (SYSTEM:HEADers ON) so you can identify each response value in the response string.

**Syntax** All valid queries are listed in the Syntax column of Tables 2–20 and 2–21.

**Table 2–20: Syntax table for SENSE:DATA:TELEcom:MEASure:POINter queries**

Syntax	Response
SENSE:DATA:TELECOM:MEASURE:POINter?	All pointer measurements
SENSE:DATA:TELECOM:MEASURE:POINter:NDFSeconds?	Number of seconds in which one or more NDFs (new data flags) occurred
SENSE:DATA:TELECOM:MEASURE:POINter:IPSeconds?	Number of seconds in which one or more illegal pointer adjustments occurred
SENSE:DATA:TELECOM:MEASURE:POINter:PPTR?	Number of positive pointer justifications
SENSE:DATA:TELECOM:MEASURE:POINter:NPTR?	Number of negative pointer justifications
SENSE:DATA:TELECOM:MEASURE:POINter:ICount?	Number of invalid pointers

All responses are in NR1-numeric format.

Table 2–21: Syntax table for SENSE:DATA:TELEcom:MEASure:POINter queries (Add/Drop Test Option Only)

Syntax	Response
SENSE:DATA:TELEcom:MEASure:POINter:VTPPTR?	Number of tributary positive pointer justifications
SENSE:DATA:TELEcom:MEASure:POINter:VTNPTR?	Number of tributary negative pointer justifications
SENSE:DATA:TELEcom:MEASure:POINter:VTICount?	Number of tributary invalid pointers
SENSE:DATA:TELEcom:MEASure:POINter:VTNDFSeconds?	Number of seconds in which one or more tributary NDFs (new data flags) occurred
SENSE:DATA:TELEcom:MEASure:POINter:VTIPSec?	Number of seconds in which one or more illegal tributary pointer adjustments occurred

All responses are in NR1-numeric format.

**Response** See the Response column of Tables 2–20 and 2–21.

**Dependencies** These measurement queries can be sent at any time. However, if a test is currently running, the responses to the queries might not represent the final error measurements. After a test has been stopped or the test duration has expired, you can send these measurement queries again to get the final error measurements.

**Errors and Events** None

**Examples** See Table 2–22.

Table 2–22: Example table for SENSE:DATA:TELEcom:MEASure:POINter queries

Query	Response
SENSE:DATA:TELECOM:MEASURE:POINTER:PPTR?	12
SENSE:DATA:TELECOM:MEASURE:POINTER:ICOUNT?	0

**Related Commands** SENSE:DATA:TELEcom:TEST:START  
SENSE:DATA:TELEcom:TEST:STOP

## SENSe:DATA:TELEcom:MEASure:BUFFer

This command sets or queries the buffer that is read with the measurement queries. The following buffers are available for use: buffer number 1 contains results from the most recent test, and buffer number 2 contains results from the previous test. The current test results might overflow into the previous test results buffer (buffer number 2). In that case, only buffer number 1 is available for use. Use the `SENSe:DATA:TELEcom:MEASure:BUFFer:AVAILable?` query to determine the oldest available buffer.

Buffer number `-1` contains results that have been accessed from disk. After you give the `MMEMory:LOAD:RESUlts` command, the buffer number is set to `-1`.

**Syntax** `SENSe:DATA:TELEcom:MEASure:BUFFer <results buffer>`  
`SENSe:DATA:TELEcom:MEASure:BUFFer?`

Parameters	<results buffer> (NR1-numeric)	description
	1 or 2	Buffer number read with the measurement queries (default = 1)
	-1	Information from the <code>MMEMory:LOAD:RESUlts</code> command is stored in this buffer

**Dependencies** None

**Errors and Events** 200, "Execution error; Temporary buffer is empty"

**Examples**

Set: `SENSe:DATA:TELECOM:MEASURE:BUFFER 2`

Query: `SENSe:DATA:TELECOM:MEASURE:BUFFER?`

Response: 2

**Related Commands** `SENSe:DATA:TELEcom:MEASure:INFORMation?`  
`SENSe:DATA:TELEcom:MEASure:BUFFer:AVAILable`  
`MMEMory:LOAD:RESUlts`



## SENSe:DATA:TELEcom:MEASure:BUFFer:AVAIlable?

This query returns the oldest buffer accessible with the measurement and history queries. The value returned by this query is the maximum value you can use in the SENSe:DATA:TELEcom:MEASure:BUFFer command.

Buffer number 1 contains results from the most recent test. Buffer number 2 contains results from the previous test. The current results might overflow into the previous test results buffer (buffer number 2). In that case, only buffer number 1 is available for use.

While a test is running, the response to this query is always 1 because only current test results can be displayed at that time.

**Syntax** SENSe:DATA:TELEcom:MEASure:BUFFer:AVAIlable?

Response	<oldest buffer> (NR1-numeric)	description
	1 or 2	Oldest buffer number read with the measurement queries (default = 1)

**Dependencies** None

**Errors and Events** None

**Examples**  
 Query: SENSe:DATA:TELECOM:MEASURE:BUFFER?  
 Response: 2

**Related Commands** SENSe:DATA:TELEcom:MEASure:BUFFer

## SENSe:DATA:TELEcom:MEASure:INFORmation Queries

This query returns information on the buffer accessed with the measurement and history queries.

**Syntax** All valid queries are listed in the Syntax column of Table 2–23.

**Table 2–23: Syntax table for SENSe:DATA:TELEcom:MEASure:INFORmation queries**

Syntax	Response
SENSe:DATA:TELEcom:MEASure:INFORmation?	[All measurement information]
SENSe:DATA:TELEcom:MEASure:INFORmation:DATE?	year, month, day [the date the test starts]
SENSe:DATA:TELEcom:MEASure:INFORmation:DESCRiption?	[Description of the test]
SENSe:DATA:TELEcom:MEASure:INFORmation:FRAMing?	[Tributary framing]
SENSe:DATA:TELEcom:MEASure:INFORmation:INSTRument?	[Instrument identity]
SENSe:DATA:TELEcom:MEASure:INFORmation:JITter:CLOCK:RATE?	[Jitter measurement clock rate]
SENSe:DATA:TELEcom:MEASure:INFORmation:JITter:FILTter?	[Jitter measurement band filter setting]
SENSe:DATA:TELEcom:MEASure:INFORmation:JITter:FILTter: FULLband:HPASs?	U_1, U1, U10
SENSe:DATA:TELEcom:MEASure:INFORmation:JITter:MODE?	[Jitter measurement mode]
SENSe:DATA:TELEcom:MEASure:INFORmation:JITter:RANGE?	[Jitter measurement range]
SENSe:DATA:TELEcom:MEASure:INFORmation:JITter:SOURce?	[Jitter measurement source]
SENSe:DATA:TELEcom:MEASure:INFORmation:LENGth?	[Length of the test information in “buckets”]
SENSe:DATA:TELEcom:MEASure:INFORmation:MAPPing?	EQUIpped, UNEQUIpped, TUASync, TU3, M140
SENSe:DATA:TELEcom:MEASure:INFORmation:OPTions?	[Instrument options]
SENSe:DATA:TELEcom:MEASure:INFORmation:OWNer?	[Same information as the SYSTem:OWNer? query]
SENSe:DATA:TELEcom:MEASure:INFORmation:RATE?	STM0, STM1, STM4 M2, M34, M140 (Add/Drop Test Option Only)
SENSe:DATA:TELEcom:MEASure:INFORmation:RESolution?	MIN1, MIN15, SEC1 [Resolution of acquired data]
SENSe:DATA:TELEcom:MEASure:INFORmation:SOURce?	INPUT1, INPUT2, INPUT3 [SDH or tributary signal]
SENSe:DATA:TELEcom:MEASure:INFORmation:STATus?	EMPTY, RECORDING, COMPLETE
SENSe:DATA:TELEcom:MEASure:INFORmation:STRUcture?	AU3, AU4

**Table 2–23: Syntax table for SENSE:DATA:TELEcom:MEASure:INFORmation queries (Cont.)**

Syntax	Response
SENSE:DATA:TELEcom:MEASure:INFORmation:TIME?	hour,minute [the time the test starts]
SENSE:DATA:TELEcom:MEASure:INFORmation:USER?	[Same information as the SYSTEM:USER? query]

The status, time, date, and length responses are in NR1-numeric format.

All other responses are in string format.

If structure, mapping, and framing do not apply to the received signal, the response is NONE.

**Response** See the Response column of Table 2–23.

**Dependencies** Information is valid only when a test is completed. Set SENSE:DATA:TELEcom:MEASure:BUFFer to the buffer for which you want information.

**Errors and Events** 200, “Execution error; Test is still running”

**Examples** See Table 2–24.

**Table 2–24: Example table for SENSE:DATA:TELEcom:MEASure:INFORmation queries**

Query	Response
SENSE:DATA:TELECOM:MEASURE:INFORMATION:TIME?	14,22,0
SENSE:DATA:TELECOM:MEASURE:INFORMATION:DESCRIPTION?	"PORTLAND TO SEATTLE NETWORK TEST"
SENSE:DATA:TELECOM:MEASURE:INFORMATION:MAPPING?	EQUIPPED

**Related Commands** SENSE:DATA:TELEcom:MEASure:BUFFer

## SENSE:DATA:TELEcom:MEASure:TSCAn?

This query returns Trouble Scan Information to help you determine the severity of errors during a test. The information in the response is for human interpretation only and is highly variable depending upon the signal being tested and whether or not the test is complete.

**Syntax** SENSE:DATA:TELEcom:MEASure:TSCAn?

<b>Response</b>	<b>&lt;tscan information&gt; (string)</b>	<b>description</b>
	A string, maximum length of 256 bytes	Information about a test currently running or complete

**Dependencies**    None

**Examples**    Query:    SENSE:DATA:TELECOM:MEASURE:TSCAN?  
              Response: "NO ALARMS, BER: 1.2E-8"

**Related Commands**    None

## SENSe:DATA:TELEcom:MEASure:STESts Subsystem

This section describes each of the commands and queries that allow you to apply predefined criteria to test results and determine if the tests passed or failed. Figure 2–36 shows the hierarchy tree for this subsystem.

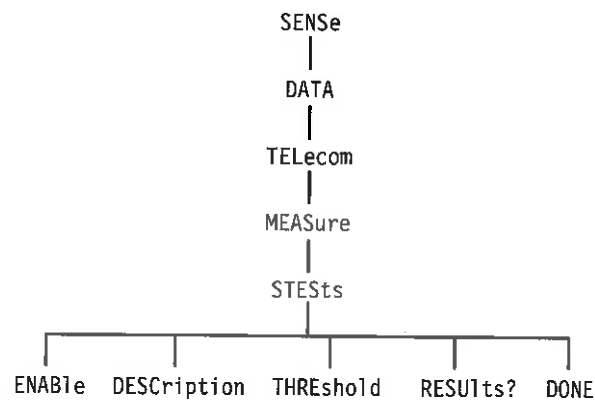

Figure 2–36: SENSE:DATA:TELEcom:MEASure:STESts subsystem

## SENSe:DATA:TELEcom:MEASure:STESts:ENABle

This command sets or queries the evaluation of pass/fail tests. The enable will revert to OFF (0) after the pass/fail test is evaluated.

**Syntax**      SENSe:DATA:TELEcom:MEASure:STESts:ENABle <stests enable>  
 SENSe:DATA:TELEcom:MEASure:STESts:ENABle?

Parameters	<stests enable> (boolean)	Description
	OFF or 0	No evaluation (default)
	ON or 1	Measurements evaluated

**Dependencies**      None

**Errors and Events**      None

**Examples**

Set:            SENSe:DATA:TELECOM:MEASURE:STESTS:ENABle ON

Query:        SENSe:DATA:TELECOM:MEASURE:STESTS:ENABle?

Response:    1

**Related Commands**      SENSe:DATA:TELEcom:MEASure:STESts:THREShold

## SENSe:DATA:TELEcom:MEASure:STESts:DESCRiption

This command sets the pass/fail test description. This description is stored on the disk with the pass/fail test. The start and end prompts appear in the SAVE PASS/FAIL TESTS menu.

**Syntax**      SENSe:DATA:TELEcom:MEASure:STESts:DESCRiption <descr>,  
 <start prompt>,<end prompt>  
 SENSe:DATA:TELEcom:MEASure:STESts:DESCRiption?

Parameters	<description> (string)	Description
	An ASCII string, maximum length of 25 bytes	The pass/fail test description
	<start prompt> (string)	Description
	An ASCII string, maximum length of 75 bytes	Text to prompt the operator at the start of the test
	<end prompt> (string)	Description
	An ASCII string, maximum length of 75 bytes	Text to prompt the operator at the end of the test

**Dependencies** None

**Errors and Events** None

**Examples**

Set: SENSE:DATA:TELECOM:MEASURE:STESTS:DESCRIPTION  
"REMEMBER TO DISCONNECT FROM EQUIPMENT"

Query: SENSE:DATA:TELECOM:MEASURE:STESTS:DESCRIPTION?

Response: "CONNECT TO EQUIPMENT"

**Related Commands** SENSE:DATA:TELECOM:MEASURE:STESTS:THRESHOLD

## SENSE:DATA:TELECOM:MEASURE:STESTS:THRESHOLD

This command sets or queries the pass/fail test criteria. The pass/fail result is determined by applying the criteria given by this command after the current test is completed. You can set up a maximum of four sets of pass/fail criteria.

**Syntax** SENSE:DATA:TELECOM:MEASURE:STESTS:THRESHOLD <criteria number>, <type>, <source>, <threshold>  
SENSE:DATA:TELECOM:MEASURE:STESTS:THRESHOLD?

**Parameters**

<b>&lt;criteria number&gt; (discrete)</b>	<b>Description</b>
1	First set of pass/fail criteria
2	Second set of pass/fail criteria
3	Third set of pass/fail criteria
4	Fourth set of pass/fail criteria

<b>&lt;type&gt; (discrete)</b>	<b>Description</b>
NONE	No pass/fail criteria
ALARm	Alarms are the pass/fail criteria
FAILure	Failures are the pass/fail criteria
ERATio	Bit error ratio is the pass/fail criterion
ECOUnt	Error count is the pass/fail criterion
ESEConds	Errored seconds are the pass/fail criteria
POINter	Pointer movements are the pass/fail criteria
JITter	Jitter is the pass/fail criteria

**<type> = NONE**

<b>&lt;source&gt; (discrete)</b>	<b>Description</b>
NONE	No pass/fail criteria

<b>&lt;threshold&gt; (discrete)</b>	<b>Description</b>
0	No threshold

**<type> = ALARm**

<b>&lt;source&gt; (discrete)</b>	<b>Description</b>
ANY	Any alarm
LAIS	MS alarm indication signal
PAIS	Path AIS
VT AIS	TU AIS (Add/Drop Test Option Only)
VTFERf	TU FERF (Add/Drop Test Option Only)
AIS	PDH AIS (Add/Drop Test Option Only)
RAI	PDH RAI (Add/Drop Test Option Only)



**<type> = ALARm**

<b>&lt;threshold&gt; (discrete)</b>	<b>Description</b>
DETEcted	Threshold is detected
NDETEcted	Threshold is not detected

**<type> = FAILure**

<b>&lt;source&gt; (discrete)</b>	<b>Description</b>
LOSignal	Loss of Signal
LOFrame	Loss of Frame
LOPointer	AU Loss of Pointer
LOPS	PDH loss of pattern sync (Add/Drop Test Option Only)
VTLOPointer	TU Loss of Pointer (Add/Drop Test Option Only)
VTLOM	TU Loss of Multiframe (Add/Drop Test Option Only)

<b>&lt;threshold&gt; (discrete)</b>	<b>Description</b>
DETEcted	Threshold is detected
NDETEcted	Threshold is not detected

**<type> = ERATio, ECOUnt, or ESEConds**

<b>&lt;source&gt; (discrete)</b>	<b>Description</b>
ANY	Any of the errors below
SCV	B1 error
LCV	B2 error
PCV	B3 error
BIT	BIT error
CRC	Cyclic redundancy check (2 Mb/s PCM30CRC or PCM31CRC only)
VTBIP	TU BIP (Add/Drop Test Option Only)
VTFEBe	TU far end block error (Add/Drop Test Option Only)

**<type> = ERATio, ECOUnt, or ESEConds (cont.)**

<b>&lt;threshold&gt; (NR3-numeric)</b>	<b>Description</b>
Any number	The test will fail for any level greater than this value

**<type> = POINter**

<b>&lt;source&gt; (discrete)</b>	<b>Description</b>
SPENdf	AU new data flag
SPEJust	AU pointer justification
VTNdf	TU new data flag (Add/Drop Test Option Only)
VTJUst	TU pointer justification (Add/Drop Test Option Only)

<b>&lt;threshold&gt; (NR3-numeric)</b>	<b>Description</b>
Any number	The test will fail for any level greater than this value

**<type> = JITter**

<b>&lt;source&gt; (discrete)</b>	<b>Description</b>
HSEConds	Jitter hit seconds

<b>&lt;threshold&gt; (NR3-numeric)</b>	<b>Description</b>
Any number	The test will fail for any level greater than this value

**Dependencies**      SENSE:DATA:TELEcom:STESSts:ENABLE must be set to ON for this command to apply.

**Errors and Events**      None

**Examples**

Set:            SENSE:DATA:TELECOM:MEASURE:STESTS:THRESHOLD  
                  1,ALARM,ANY,DETECTED

Query:        SENSE:DATA:TELECOM:MEASURE:STESTS:THRESHOLD? 1

Response:    ALARM,ANY,DETECTED

**Related Commands**      SENSE:DATA:TELEcom:STESSts:ENABLE

## SENSE:DATA:TELEcom:MEASure:STESts:RESUlts?

This query returns the results of applying the pass/fail criteria to the pass/fail test measurements.

**Syntax** SENSE:DATA:TELEcom:MEASure:STESts:RESUlts?

Response	<test results> (discrete)	Description
	NONE	Test is still running or no pass/fail test measurements have been requested
	PASSED	Test passed
	FAILED	Test failed

**Dependencies** The test must be completed for the results to be valid.

**Errors and Events** 200, "Execution error; Results not available"

**Examples** Query: SENSE:DATA:TELECOM:MEASURE:STESTS:RESULTS?

Response: PASSED

**Related Commands** SENSE:DATA:TELEcom:MEASure:STESts:THREShold

## SENSe:DATA:TELEcom:MEASure:STESTs:DONE

This command sets or queries what action the instrument takes when the pass/fail test calculations complete.

**NOTE.** The pass/fail test results are written to the file name specified by the MMEMory:STORe:TESTs command. So, if you run consecutive pass/fail tests, remember to send the MMEMory:STORe:TESTs command with unique file names in between each pass/fail test run so the pass/fail test results files are not overwritten.

**Syntax** SENSe:DATA:TELEcom:MEASure:STESTs:DONE <action>  
SENSe:DATA:TELEcom:MEASure:STESTs:DONE?

**Parameters**

<action> (discrete)	Description
NONE	Take no action when pass/fail tests calculations complete
PRINT	Print the pass/fail tests results
DISK	Save the pass/fail tests results to disk; the file name is specified by the MMEMory:STORe:TESTs command

**Dependencies** None

**Errors and Events** None

**Examples**  
Set:       SENSe:DATA:TELECOM:MEASURE:STESTS:DONE NONE  
Query:     SENSe:DATA:TELECOM:MEASURE:STESTS:DONE?  
Response:  DISK

**Related Commands** SENSe:DATA:TELEcom:MEASure:STESTs:ENABLE  
SENSe:DATA:TELEcom:MEASure:STESTs:THREShold  
MMEMory:STORe:TESTs

## SENSe:DATA:TELEcom:MEASure:JITter Subsystem

This section describes the SENSE:DATA:TELEcom:MEASure:JITter subsystem commands and queries. Figure 2–37 shows the hierarchy tree for this subsystem.

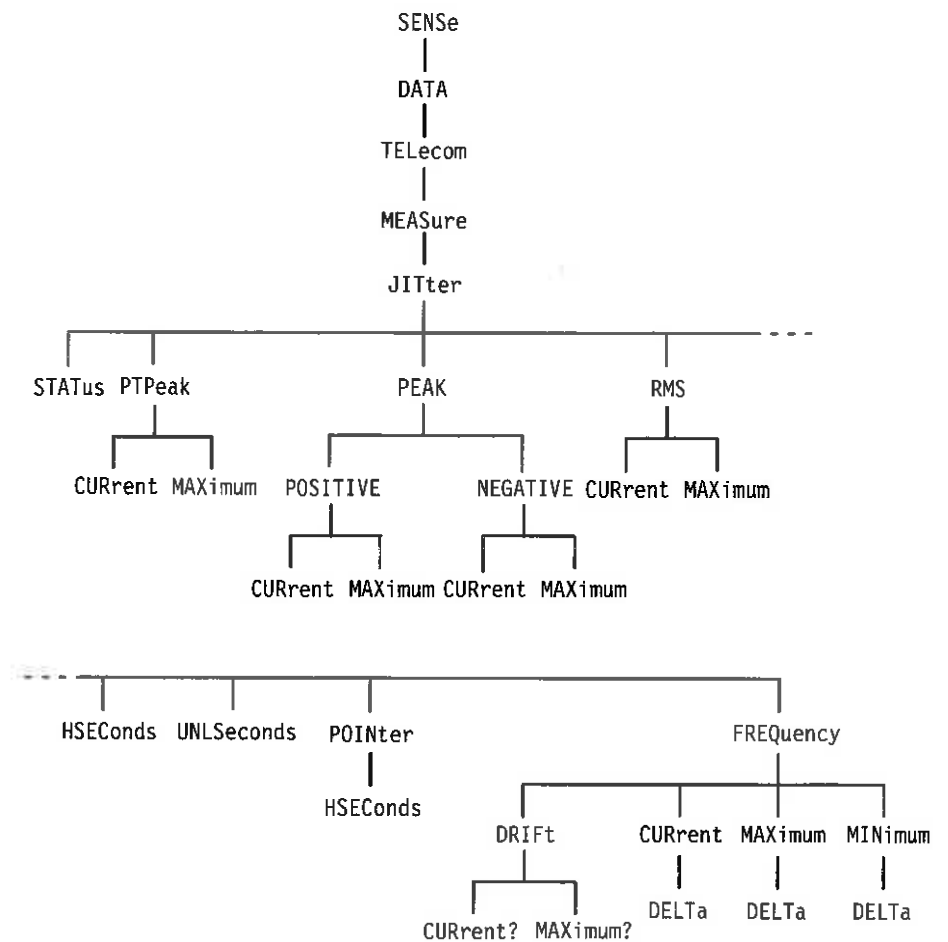

Figure 2–37: SENSE:DATA:TELEcom:MEASure:JITter subsystem

## SENSe:DATA:TELEcom:MEASure:JITter:STATus?

SDH/PDH Jitter/Wander Test Option Only

This query returns the status of jitter test measurements.

**Syntax** SENSe:DATA:TELEcom:MEASure:JITter:STATus?

**Response**

<jit stat> (discrete)	Description
VALID	Measurements valid
UNLOCKed	Measurements invalid due to loss of signal lock or out-of-range jitter measurement
WAIT	Measurements invalid because hardware is initializing

**Dependencies** Requires installation of Option 14 jitter module.

**Errors and Events** None

**Examples**  
 Query: SENSe:DATA:TELECOM:MEASURE:JITTER:STATUS?  
 Response: VALID

**Related Commands** None

## SENSe:DATA:TELEcom:MEASure:JITter:PTPeak:CURrent?

SDH/PDH Jitter/Wander Test Option Only

This query returns the jitter peak-to-peak amplitude. When a test is running, this command returns the current peak-to-peak jitter amplitude of the running test. When a test is not running, this command returns the last-measured peak-to-peak jitter amplitude.

**Syntax** SENSe:DATA:TELEcom:MEASure:JITter:PTPeak:CURrent?

Response	<jitter ptp> (NR3-numeric)	Description
	Floating point number in the range of 0 to 200	Jitter peak-to-peak amplitude in UI

**Dependencies** Requires installation of Option 14 jitter module.  
SENSe:DATA:TELEcom:JITter:MODE must be set to PTP

**Errors and Events** None

**Examples** Query: SENSE:DATA:TELECOM:MEASURE:JITTER:PTPEAK:CURRENT?  
Response: 1.6

**Related Commands** SENSe:DATA:TELEcom:JITter:MODE

## SENSe:DATA:TELEcom:MEASure:JITter:PTPeak:MAXimum?

SDH/PDH Jitter/Wander Test Option Only

This query returns the maximum peak-to-peak jitter amplitude since the beginning of the current test.

**Syntax** SENSe:DATA:TELEcom:MEASure:JITter:PTPeak:MAXimum?

Response	<jitter ptp max> (NR3-numeric)	Description
	Floating point number in the range of 0 to 200	Maximum jitter peak-to-peak amplitude in UI

**Dependencies** Requires installation of Option 14 jitter module.  
SENSe:DATA:TELEcom:JITter:MODE must be set to PTP

**Errors and Events** None

**Examples** Query: SENSE:DATA:TELECOM:MEASURE:JITTER:PTPEAK:MAXIMUM?

Response: 1.6

**Related Commands** SENSE:DATA:TELEcom:JITter:MODE

## SENSe:DATA:TELEcom:MEASure:JITter:PEAK:POSITIVE:CURrent?

SDH/PDH Jitter/Wander Test Option Only

This query returns the jitter positive peak amplitude. When a test is running, this command returns the current jitter positive peak amplitude of the running test. When a test is not running, this command returns the last-measured jitter positive peak amplitude.

**Syntax** SENSE:DATA:TELEcom:MEASure:JITter:PEAK:POSITIVE:CURrent?

Response	<jitter pmax> (NR3-numeric)	Description
	Floating point number in the range of 0 to 200	Jitter positive peak amplitude in UI

**Dependencies** Requires installation of Option 14 jitter module.

SENSe:DATA:TELEcom:JITter:MODE must be set to PTP

**Errors and Events** None

**Examples** Query: SENSE:DATA:TELECOM:MEASURE:JITTER:PEAK:POSITIVE:  
CURrent?

Response: 0.6

**Related Commands** SENSE:DATA:TELEcom:JITter:MODE



**SENSe:DATA:TELEcom:MEASure:JITter:PEAK:POSITIVE:MAXimum?**

SDH/PDH Jitter/Wander Test Option Only

This query returns the jitter maximum positive peak amplitude since the beginning of the current test.

**Syntax**      SENSE:DATA:TELEcom:MEASure:JITter:PEAK:POSITIVE:MAXimum?

Response	<jitter pmax> (NR3-numeric)	Description
	Floating point number in the range of 0 to 200	Maximum jitter positive peak amplitude in UI

**Dependencies**      Requires installation of Option 14 jitter module.

SENSe:DATA:TELEcom:JITter:MODE must be set to PTP

**Errors and Events**      None

**Examples**      Query:      SENSE:DATA:TELECOM:MEASURE:JITTER:PEAK:POSITIVE:  
MAXIMUM?

Response: 0.6

**Related Commands**      SENSE:DATA:TELEcom:JITter:MODE

**SENSe:DATA:TELEcom:MEASure:JITter:PEAK:NEGATIVE:CURrent?**

SDH/PDH Jitter/Wander Test Option Only

This query returns the jitter negative peak amplitude. When a test is running, this command returns the current jitter negative peak amplitude of the running test. When a test is not running, this command returns the last-measured jitter negative peak amplitude.

**Syntax**      SENSE:DATA:TELEcom:MEASure:JITter:PEAK:NEGATIVE:CURrent?

Response	<jitter pmax> (NR3-numeric)	Description
	Floating point number in the range of 0 to 200	Jitter negative peak amplitude in UI

**Dependencies** Requires installation of Option 14 jitter module.  
SENSe:DATA:TELEcom:JITter:MODE must be set to PTP

**Errors and Events** None

**Examples** Query: SENSE:DATA:TELECOM:MEASURE:JITTER:PEAK:NEGATIVE:CURRENT?  
Response: -0.6

**Related Commands** SENSe:DATA:TELEcom:JITter:MODE

### SENSe:DATA:TELEcom:MEASure:JITter:PEAK:NEGATIVE:MAXimum?

SDH/PDH Jitter/Wander Test Option Only

This query returns the jitter maximum negative peak amplitude since the beginning of the current test.

**Syntax** SENSe:DATA:TELEcom:MEASure:JITter:PEAK:NEGATIVE:MAXimum?

Response	<jitter pnmax> (NR3-numeric)	Description
	Floating point number in the range of 0 to 200	Maximum jitter negative peak amplitude in UI

**Dependencies** Requires installation of Option 14 jitter module.  
SENSe:DATA:TELEcom:JITter:MODE must be set to PTP

**Errors and Events** None

**Examples** Query: SENSE:DATA:TELECOM:MEASURE:JITTER:PEAK:NEGATIVE:MAXIMUM?  
Response: -0.6

**Related Commands** SENSe:DATA:TELEcom:JITter:MODE

**SENSe:DATA:TELEcom:MEASure:JITter:RMS:CURrent?**

SDH/PDH Jitter/Wander Test Option Only

This query returns the jitter RMS value. When a test is running, this command returns the current jitter RMS value of the running test. When a test is not running, this command returns the last-measured jitter RMS value.

**Syntax** SENSE:DATA:TELEcom:MEASure:JITter:RMS:CURrent?

Response	<jitter rms> (NR3-numeric)	Description
	Floating point number in the range of 0 to 5.0	Jitter RMS value in UI

**Dependencies** Requires installation of Option 14 jitter module.

SENSe:DATA:TELEcom:JITter:MODE must be set to RMS

**Errors and Events** None

**Examples** Query: SENSE:DATA:TELECOM:MEASURE:JITTER:RMS:CURRENT?

Response: 1.6

**Related Commands** SENSE:DATA:TELEcom:JITter:MODE

**SENSe:DATA:TELEcom:MEASure:JITter:RMS:MAXimum?**

SDH/PDH Jitter/Wander Test Option Only

This query returns the jitter maximum jitter RMS since the beginning of the current test.

**Syntax** SENSE:DATA:TELEcom:MEASure:JITter:RMS:MAXimum?

Response	<jitter rms max> (NR3-numeric)	Description
	Floating point number in the range of 0 to 5.0	Maximum jitter RMS in UI

**Dependencies** Requires installation of Option 14 jitter module.  
SENSe:DATA:TELEcom:JITter:MODE must be set to RMS

**Errors and Events** None

**Examples** Query: SENSE:DATA:TELECOM:MEASURE:JITTER:RMS:MAXIMUM?  
Response: 1.4

**Related Commands** SENSE:DATA:TELEcom:JITter:MODE

## SENSe:DATA:TELEcom:MEASure:JITter:HSEConds?

SDH/PDH Jitter/Wander Test Option Only

This query returns the number of jitter hit seconds since the beginning of the test.

**Syntax** SENSE:DATA:TELEcom:MEASure:JITter:HSEConds?

Response	<jitter hsecs> (NR1-numeric)	Description
	Integer in the range of 0 to number of seconds in the test	Number of jitter hit seconds

**Dependencies** Requires installation of Option 14 jitter module.

**Errors and Events** None

**Examples** Query: SENSE:DATA:TELECOM:MEASURE:JITTER:HSECONDS?  
Response: 2

**Related Commands** None

**SENSe:DATA:TELEcom:MEASure:JITter:UNLSeconds?**

SDH/PDH Jitter/Wander Test Option Only

This query returns the number of jitter unlock seconds since the beginning of the test. This is the number of seconds that jitter could not be measured because the jitter signal was out of measurement range.

**Syntax**      **SENSe:DATA:TELEcom:MEASure:JITter:UNLSeconds?**

Response	<jitter unls> (NR1-numeric)	Description
	Integer in the range of 0 to number of seconds in the test	Number of jitter unlock seconds

**Dependencies**      Requires installation of Option 14 jitter module.

**Errors and Events**      None

**Examples**      Query:      **SENSe:DATA:TELECOM:MEASURE:JITTER:UNLSECONDS?**

Response: 2

**Related Commands**      None

**SENSe:DATA:TELEcom:MEASure:JITter:POINter:HSEConds?**

SDH/PDH Jitter/Wander Test Option Only

This query returns the number of jitter pointer hit seconds since the beginning of the test.

**Syntax**      **SENSe:DATA:TELEcom:MEASure:JITter:POINter:HSEConds?**

Response	<jitter evs> (NR1-numeric)	Description
	Integer in the range of 0 to the number of seconds in the test	Number of jitter pointer hit seconds

**Dependencies** Requires installation of Option 14 jitter module.  
 PDH mapping must be selected.  
 Does not apply when the jitter source is set to clock, 52, 155, or 622 mB rates.  
 Use SENSE:DATA:TELEcom:JITter:POINter:THREShold to set the hit second threshold.

**Errors and Events** None

**Examples** Query: SENSE:DATA:TELECOM:MEASURE:JITTER:POINTER:HSECONDS?  
 Response: 2

**Related Commands** SENSE:DATA:TELEcom:JITter:POINter:THREShold

## SENSE:DATA:TELEcom:MEASure:JITter:FREQUency:DRIFT:CURrent?

SDH/PDH Jitter/Wander Test Option Only

This query returns the video-related jitter frequency drift rate. When a test is running, this command returns the current jitter frequency drift rate value of the running test. When a test is not running, this command returns the last-measured jitter frequency drift rate value.

**Syntax** SENSE:DATA:TELEcom:MEASure:JITter:FREQUency:DRIFT:CURrent?

Response	<jitter drift> (NR3-numeric)	Description
	Floating point number in the range of 0 to 100.0	Video-related jitter frequency drift rate, in ppm/sec

**Dependencies** Requires installation of Option 14 jitter module.

**Errors and Events** None

**Examples**    Query:    SENSE:DATA:TELECOM:MEASURE:JITTER:FREQUENCY:DRIFT:  
CURRENT?

Response: 10.6

**Related Commands**    None

## SENSe:DATA:TELEcom:MEASure:JITter:FREQuency:DRIFt:MAXimum?

SDH/PDH Jitter/Wander Test Option Only

This query returns the maximum video-related jitter frequency drift since the beginning of the current test.

**Syntax**    SENSE:DATA:TELEcom:MEASure:JITter:FREQuency:DRIFt:MAXimum?

Response	<jitter drift max> (NR3-numeric)	Description
	Floating point number in the range of 0 to 100.0	Maximum video-related jitter frequency drift rate, in ppm/sec

**Dependencies**    Requires installation of Option 14 jitter module.

**Errors and Events**    None

**Examples**    Query:    SENSE:DATA:TELECOM:MEASURE:JITTER:FREQUENCY:DRIFT  
:MAXIMUM?

Response: 10.8

**Related Commands**    None

**SENSe:DATA:TELEcom:MEASure:JITter:FREQuency:CURrent?**

SDH/PDH Jitter/Wander Test Option Only

This query returns the jitter source (line or clock) receive-rate frequency. When a test is running, this command returns the current receive-rate frequency of the running test. When a test is not running, this command returns the last-measured receive-rate frequency.

**Syntax** SENSe:DATA:TELEcom:MEASure:JITter:FREQuency:CURrent?

**Response**

<jitter rcv> (NR3-numeric)	Description
Floating point number in the range of 0 Hz to 622 MHz	Current jitter receive frequency in Hz

**Dependencies** Requires installation of Option 14 jitter module.

**Errors and Events** None

**Examples**  
 Query: SENSe:DATA:TELECOM:MEASURE:JITTER:FREQUENCY:CURRENT?  
 Response: 34.367999E+6

**Related Commands** None

**SENSe:DATA:TELEcom:MEASure:JITter:FREQuency:CURrent:DELTA?**

SDH/PDH Jitter/Wander Test Option Only

This query returns the delta of the current frequency from the ideal frequency. When a test is running, this command returns the current receive-rate frequency delta of the running test. When a test is not running, this command returns the last-measured receive-rate delta frequency.

**Syntax** SENSe:DATA:TELEcom:MEASure:JITter:FREQuency:CURrent:DELTA?



Response	<jitter rcv> (NR3-numeric)	Description
	Floating point number in the range of -100.0 to 100.0	Delta of the current frequency in ppm. Resolution is 0.01 ppm

**Dependencies** Requires installation of Option 14 jitter module.

**Errors and Events** None

**Examples** Query: SENSE:DATA:TELECOM:MEASURE:JITTER:FREQUENCY:CURRENT:DELTA?

Response: 10.01

**Related Commands** None

## SENSe:DATA:TELEcom:MEASure:JITter:FREQuency:MAXimum?

SDH/PDH Jitter/Wander Test Option Only

This query returns the maximum jitter source (line or clock) receive-rate frequency since the beginning of the current test.

**Syntax** SENSe:DATA:TELEcom:MEASure:JITter:FREQuency:MAXimum?

Response	<Jit recfreq max> (NR3-numeric)	Description
	Floating point number in the range of 0 Hz to 622 MHz	Maximum receive rate frequency in Hz

**Dependencies** Requires installation of Option 14 jitter module.

**Errors and Events** None

**Examples** Query: SENSE:DATA:TELECOM:MEASURE:JITTER:FREQUENCY:MAXIMUM?

Response: 34.368E+6

**Related Commands** None

## SENSe:DATA:TELEcom:MEASure:JITter:FREQUency:MAXimum:DELTA?

SDH/PDH Jitter/Wander Test Option Only

This query returns the maximum jitter source (line or clock) receive-rate frequency delta since the beginning of the current test.

**Syntax** SENSe:DATA:TELEcom:MEASure:JITter:FREQUency:MAXimum:DELTA?

**Response**

<freq max delta> (NR3-numeric)	Description
Floating point number in the range of -100 to 100	Maximum receive rate frequency delta in ppm

**Dependencies** Requires installation of Option 14 jitter module.

**Errors and Events** None

**Examples** Query: SENSE:DATA:TELECOM:MEASURE:JITTER:FREQUENCY:MAXIMUM:DELTA?

Response: 10.2

**Related Commands** None

**SENSe:DATA:TELEcom:MEASure:JITter:FREQuency:MINimum?**

SDH/PDH Jitter/Wander Test Option Only

This query returns the minimum jitter source (line or clock) receive-rate frequency since the beginning of the current test.

**Syntax**      **SENSe:DATA:TELEcom:MEASure:JITter:FREQuency:Minimum?**

Response	<jitter freq min> (NR3-numeric)	Description
	Floating point number in the range of 0 Hz to 622 MHz	Minimum receive rate frequency in Hz

**Dependencies**      Requires installation of Option 14 jitter module.

**Errors and Events**      None

**Examples**      Query:      **SENSe:DATA:TELECOM:MEASURE:JITTER:FREQUENCY:MINIMUM?**

Response: 34.367998E+6

**Related Commands**      None

**SENSe:DATA:TELecom:MEASure:JITter:FREQUency:MINimum:DELTA?**

SDH/PDH Jitter/Wander Test Option Only

This query returns the minimum jitter source (line or clock) receive-rate frequency delta since the beginning of the current test.

**Syntax** SENSe:DATA:TELecom:MEASure:JITter:FREQUency:MINimum:DELTA?

Response	<min freq delta> (NR3-numeric)	Description
	Floating point number in the range of -100.0 to 100.0	Minimum receive rate frequency delta in ppm

**Dependencies** Requires installation of Option 14 jitter module.

**Errors and Events** None

**Examples** Query: SENSe:DATA:TELECOM:MEASURE:JITTER:FREQUENCY:MINIMUM:DELTA?

Response: 10.2

**Related Commands** None

## SENSe:DATA:TELEcom:MEASure:WANDer Subsystem

This section describes the SENSe:DATA:TELEcom:MEASure:WANDer subsystem commands and queries. Figure 2–38 shows the hierarchy tree for this subsystem.

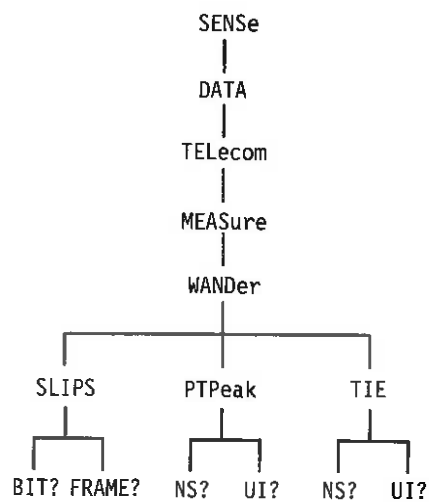

Figure 2–38: SENSe:DATA:TELEcom:MEASure:WANDer subsystem

## SENSe:DATA:TELEcom:MEASure:WANDer:SLIPS:BIT?

SDH/PDH Jitter/Wander Test Option Only

This query returns the estimated bit slips since the beginning of the test. This result is only valid for 2Mb rate.

**Syntax**      SENSE:DATA:TELEcom:MEASure:WANDer:SLIPS:BIT?

Response	<bit slips> (NR1-numeric)	Description
	Integer in the range of 0 to 4294767295	Estimated number of bit slips

**Dependencies**      Requires installation of Option 14 jitter module.  
 Receive rate must be 2Mb.

**Errors and Events**      None

**Examples**      Query:      SENSE:DATA:TELECOM:MEASURE:WANDER:SLIPS:BIT?  
                   Response: 12

**Related Commands**      None

**SENSe:DATA:TELEcom:MEASure:WANDer:SLIPS:FRAME?**

SDH/PDH Jitter/Wander Test Option Only

This query returns the estimated frame slips since the beginning of the test. This result is only valid for 2Mb rate.

**Syntax** SENSE:DATA:TELEcom:MEASure:WANDer:SLIPS:FRAME?

**Response**

<frame slips> (NR1-numeric)	Description
Integer in the range of 0 to 4294767295	Estimated number of frame slips

**Dependencies** Requires installation of Option 14 jitter module.  
Receive rate must be 2Mb.

**Errors and Events** None

**Examples** Query: SENSE:DATA:TELECOM:MEASURE:WANDER:SLIPS:FRAME?  
Response: 10

**Related Commands** None

## SENSe:DATA:TELEcom:MEASure:WANDer:PTPeak:NS?

SDH/PDH Jitter/Wander Test Option Only

This query returns the estimated maximum peak-to-peak wander amplitude in nanoseconds since the beginning of the test.

**Syntax** SENSe:DATA:TELEcom:MEASure:WANDer:PTPeak:NS?

**Response**

<wander ptp> (NR1-numeric)	Description
Integer in the range of 0 to 4294767295	Maximum peak-to-peak wander amplitude in nanoseconds

**Dependencies** Requires installation of Option 14 jitter module.

**Errors and Events** None

**Examples**  
 Query: SENSe:DATA:TELECOM:MEASURE:WANDER:PTPEAK:NS?  
 Response: 10

**Related Commands** None

## SENSe:DATA:TELEcom:MEASure:WANDer:PTPeak:UI?

SDH/PDH Jitter/Wander Test Option Only

This query returns the maximum peak-to-peak wander amplitude in UI since the beginning of the test.

**Syntax** SENSe:DATA:TELEcom:MEASure:WANDer:PTPeak:UI?

**Response**

<wander ptp> (NR3-numeric)	Description
Floating Point value in the range of 0 to 1000.0, with a resolution of 0.01	Maximum peak-to-peak wander amplitude in UI

**Dependencies** Requires installation of Option 14 jitter module.



**Errors and Events** None

**Examples** Query: SENSE:DATA:TELECOM:MEASURE:WANDER:PTPEAK:UI?  
Response: 10.5

**Related Commands** None

## SENSe:DATA:TELEcom:MEASure:WANDer:TIE:NS?

SDH/PDH Jitter/Wander Test Option Only

This query returns the TIE value in nanoseconds at the current time in the test.

**Syntax** SENSe:DATA:TELEcom:MEASure:WANDer:TIE:NS?

**Response**

<wander tie> (NR1-numeric)	Description
Integer in the range of 0 to 4294767295	Current TIE value in nanoseconds

**Dependencies** Requires installation of Option 14 jitter module.

This measurement is valid while SENSe:DATA:TELEcom:MEASure:JITter:STATus? returns VALID.

**Errors and Events** None

**Examples** Query: SENSE:DATA:TELECOM:MEASURE:WANDER:TIE:NS?  
Response: 10

**Related Commands** None

## SENSe:DATA:TELEcom:MEASure:WANDer:TIE:UI?

SDH/PDH Jitter/Wander Test Option Only

This query returns the TIE value at the current time in the test.

**Syntax**      SENSe:DATA:TELEcom:MEASure:WANDer:TIE:UI?

**Response**

<wander tie> (NR3-numeric)	Description
Floating point value in the range of 0 to 1000.0, with a resolution of 0.01	Current TIE value in UI

**Dependencies**

Requires installation of Option 14 jitter module.

This measurement is valid while SENSe:DATA:TELEcom:MEASure:JITter:STATus? returns VALID.

**Errors and Events**

None

**Examples**

Query:      SENSe:DATA:TELECOM:MEASURE:WANDER:TIE:UI?

Response: 20.5

**Related Commands**

None

## SENSe:DATA:TELEcom:MEASure:TRIButary Subsystem

Add/Drop Test Option Only

This section describes the commands and queries that access tributary error, alarm, failure, and pointer measurements for current and previous tests. Figures 2–39, 2–40, and 2–41 show the hierarchy trees for this subsystem.

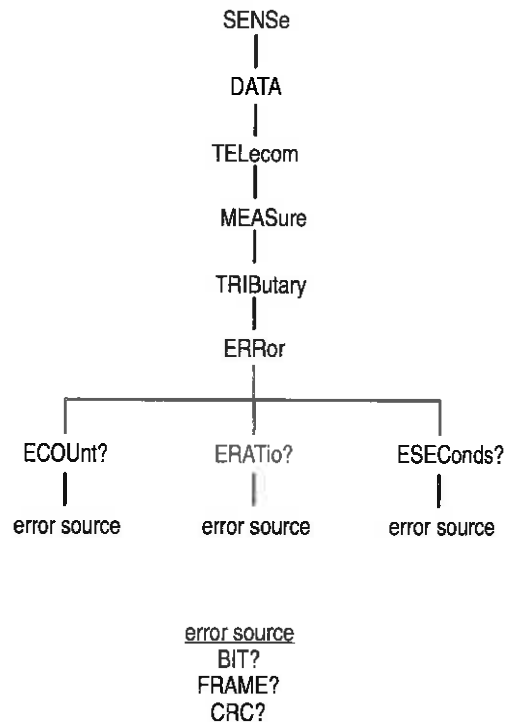
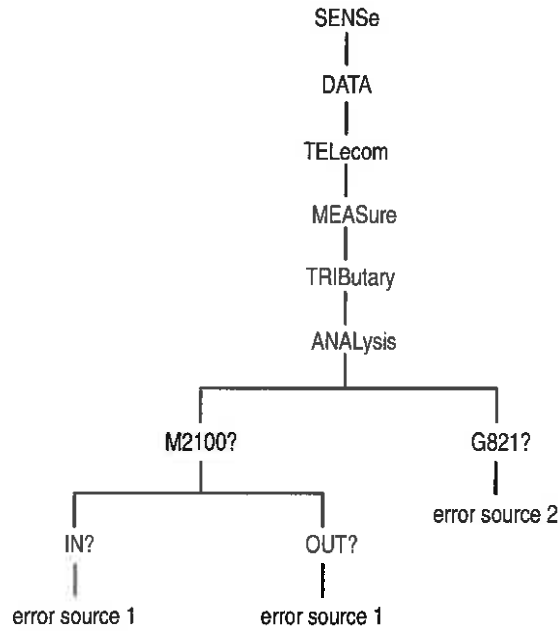

Figure 2–39: SENSE:DATA:TELEcom:MEASure:TRIButary:ERRor subsystem (PDH)



error source 1

- ESECONDS?
- PESECONDS?
- SESECONDS?
- PSESECONDS?
- UASECONDS?
- PUASECONDS?
- ESECONDS?
- PESECONDS?

error source 2

- ECOUNT?
- ESECONDS?
- PESECONDS?
- UASECONDS?
- PUASECONDS?
- ESECONDS?
- PESECONDS?
- SESECONDS?
- PSESECONDS?
- DMINUTES?
- PDMINUTES?

**Figure 2-40: SENSE:DATA:TELecom:MEASure:TRIButary:ANALysis subsystem (PDH)**

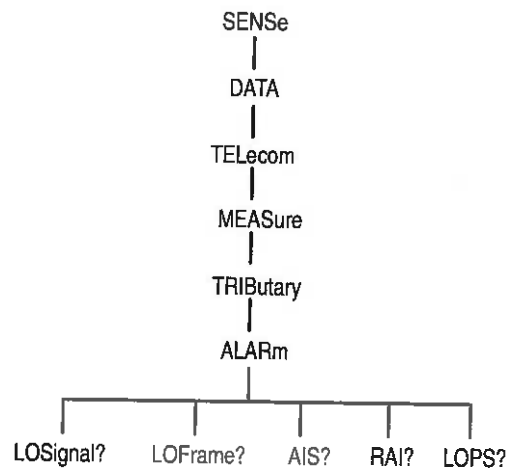

**Figure 2–41: SENSE:DATA:TELecom:MEASure:TRIButary:ALARm subsystems (PDH)**

A variety of tributary error, alarm, and failure measurements are reported through this subsystem. Table 2–25 shows how error, alarm, and failure measurements are calculated. Tables 2–26 and 2–27 show how the analysis measurements are calculated. These calculations are based on CCITT G.821 specifications.

**Table 2–25: How error and alarm measurements are calculated**

Type of measurement	Method of calculation
Error count	Number of bit errors that were errored in the signal
Bit Error Ratio (BER)	Ratio of error count to the total number of received bits
Errored seconds	Number of seconds that had any error counts
Alarms	Number of one-second intervals that contained a specific alarm such as Loss of Signal (LOS) and Loss of Frame (LOF)

**Table 2-26: How analysis measurements are calculated**

Type of measurement	Method of calculation
Error count	Number of bit errors not occurring during periods of unavailability (see Unavailable seconds)
Errored seconds	Total number of seconds that had any error count; does not include any period of unavailability (see Unavailable seconds)
Degraded minutes	Number of minutes that had a bit error ratio (BER) in the range $1 \times 10^{-6}$ to $1 \times 10^{-3}$ ; degraded minutes do not accumulate during periods of unavailability
Severely errored seconds	Number of seconds with more than N errors (see Table 2-27)
Unavailable seconds	Number of seconds that the signal had too many errors to be available for use; unavailability starts at the onset of ten contiguous severely errored seconds
Error free seconds	Number of seconds that contained zero errors

**Table 2-27: Value of N for analysis measurements (PDH)**

Tributary rate	Type of error	N
2 Mb/s	Bit error	$> 1E-3$
	Frame error	28
	CRC error	830
34 Mb/s	Bit error	$> 1E-3$
	Frame error	223
140 Mb/s	Bit error	$> 1E-3$
	Frame error	568

Some of queries in this section have their information presented in a way that is different from queries in the rest of the manual. The syntax and examples are in table format. Figure 2-42 shows you how to read the Syntax Tables in this section. Follow the step numbers to create any query. Table 2-28 explains the terms used in the SENSE:DATA:TELEcom:MEASure Syntax Tables.

- 1 Start with the syntax statement listed under Syntax.
- 3 Add a question mark or one of these items (remember to keep the colon in front of this item).

- 2 Add one of these items to the end of the syntax statement.

Table X-X: Syntax Table for SENSE:DATA:TELEcom:MEASure:TRIButary:ERRor Queries

Select a measurement from the left column	Then select an error source from the top row				
	?	:BIT?	:FRAME?	:CRC?	:PARITY?
ECOUnt	all error counts	logic errors	frame errors	CRC errors	parity errors
ERATio	all bit error ratios	logic errors	frame errors	CRC errors	parity errors
ESEConds	all errored seconds	logic errors	frame errors	CRC errors	parity errors

All error counts and errored seconds return NR1-numeric responses.  
 All bit error ratios return NR3-numeric responses.

- 4 The response type is listed in the footnote.

- 5 The response description for each combination of items is listed in each cell of the table. If no query exists for a particular combination of items, "no query" is listed in the cell.

Figure 2-42: How to read the syntax tables in the SENSE:DATA:TELEcom:MEASure:TRIButary subsystem section

Table 2-28: Terms used in the SENSE:DATA: TELEcom:MEASure:TRIButary queries

Term	Meaning
BIT	Pattern bit error
FRAME	Frame bit error
CRC	CRC error
PARITY	Parity error

Figure 2-43 shows you how to read the Example Tables in this section.

Table X-X: Example Table for SENSE:DATA:TELEcom:MEASure:TRIButary:ERRor:Queries

Query	Response
SENSE:DATA:TELECOM:MEASURE:TRIBUTARY:ERROR:ECOUNT:BIT?	714
SENSE:DATA:TELECOM:MEASURE:TRIBUTARY:ERROR:ERATIO:FRAME?	1.0E-8
SENSE:DATA:TELECOM:MEASURE:TRIBUTARY:ERROR:ESECONDS:CRC?	3

Selected examples of queries are shown in the left column

A typical response is shown in the right column for each example

Figure 2-43: How to read the example tables in the SENSE:DATA:TELEcom:MEASure:TRIButary subsystem section

## SENSE:DATA:TELEcom:MEASure:TRIButary:ERRor Queries

### Add/Drop Test Option Only

These queries return tributary error measurements. When you use the high-level queries (for example, SENSE:DATA:TELEcom:MEASure:TRIButary:ERRor? or SENSE:DATA:TELEcom:MEASure:TRIButary:ERRor:ECOUNt?), it is helpful to turn the headers on (SYSTEM:HEADers ON) so you can identify each response value in the response string.

**Syntax** SENSE:DATA:TELEcom:MEASure:TRIButary:ERRor?

SENSE:DATA:TELEcom:MEASure:TRIButary:ERRor:[measurement]:[error source] (see Table 2-29 to complete the query)

Table 2-29: Syntax table for SENSE:DATA:TELEcom:MEASure:TRIButary:ERRor queries (PDH)

Select a measurement from the left column	Then select an error source from the top row			
	?	:BIT? <sup>1</sup>	:FRAME? <sup>2</sup>	:CRC? <sup>3</sup>
ECOUNt	all error counts	logic errors	frame errors	CRC errors
ERATio	all bit error ratios	logic errors	frame errors	CRC errors
ESEConds	all errored seconds	logic errors	frame errors	CRC errors

All error counts and errored seconds return NR1-numeric responses.

All bit error ratios return NR3-numeric responses.

- <sup>1</sup> The ESECONDS:BIT error source reports M2100 out-of-service and G.821 measurements.
- <sup>2</sup> The FRAME error source is valid only for PDH framed signals.
- <sup>3</sup> The CRC error source is valid only for 2 Mb/s rate and PCM30CRC or PCM31CRC framing.



**Response** See Table 2–29.

**Dependencies** These measurement queries can be sent at any time. But, if a test is currently running, the responses to the queries might not represent the final error measurements. After a test has been stopped or the test duration has expired, you can send these measurement queries again to get the final error measurements.

Do not set `SENSe:DATA:TELEcom:TRIButary:PAYLoad:PATtern` to `UNKNown` if you want to use these queries.

**Errors and Events** None

**Examples** See Table 2–30.

**Table 2–30: Example table for `SENSe:DATA:TELEcom:MEASure:TRIButary:ERRor` queries**

Query	Response
<code>SENSe:DATA:TELECOM:MEASURE:TRIBUTARY:ERROR:ECOUNT:BIT?</code>	714
<code>SENSe:DATA:TELECOM:MEASURE:TRIBUTARY:ERROR:ERATIO:FRAME?</code>	1.0E–8
<code>SENSe:DATA:TELECOM:MEASURE:TRIBUTARY:ERROR:ESECONDS:CRC?</code>	3

**Related Commands** `SENSe:DATA:TELEcom:TEST:STARt`  
`SENSe:DATA:TELEcom:TEST:STOP`  
`SENSe:DATA:TELEcom:TRIButary:PAYLoad:PATtern`  
`SYSTem:HEADers`

## SENSe:DATA:TELEcom:MEASure:TRIButary:ANALysis Queries

### Add/Drop Test Option Only

These queries return an analysis of section, line, path, and payload errors for tributary signals. When you use the high-level queries (for example, SENSE:DATA:TELEcom:MEASure:TRIButary:ANALysis? or SENSE:DATA:TELEcom:MEASure:TRIButary:ANALysis:ECOUnT?), it is helpful to turn the headers on (SYSTEM:HEADers ON) so you can identify each response value in the response string.

**Syntax** SENSE:DATA:TELEcom:MEASure:TRIButary:ANALysis?  
 SENSE:DATA:TELEcom:MEASure:TRIButary:ANALysis:M2100?  
 SENSE:DATA:TELEcom:MEASure:TRIButary:ANALysis:M2100:IN:[error source] (see Table 2–31 to complete the query)  
 SENSE:DATA:TELEcom:MEASure:TRIButary:ANALysis:M2100:OUT:[error source] (see Table 2–31 to complete the query)  
 SENSE:DATA:TELEcom:MEASure:TRIButary:ANALysis:G821?  
 SENSE:DATA:TELEcom:MEASure:TRIButary:ANALysis:G821:[error source] (see Table 2–32 to complete the query)

**Table 2–31: SENSE:DATA:TELEcom:MEASure:TRIButary:ANALysis:M2100:IN and M2100:OUT Queries (PDH)**

Select one of these error sources	Response
?	All M2100 in- and out-of-service analysis responses below
ESECONDS	Errored seconds
PESECONDS	Percent errored seconds
UASECONDS	Unavailable seconds
PUASECONDS	Percent unavailable seconds
EFSECONDS	Error free seconds
PEFSECONDS	Percent error free seconds
SESECONDS	Severely errored seconds
PSESECONDS	Percent severely errored seconds

All percent measurements return NR3-numeric responses.

All other measurements return NR1-numeric responses.

**Table 2–32: SENSE:DATA:TELEcom:MEASure:TRIButary:ANALysis:G821 Queries (PDH)**

Select one of these error sources	Response
ECOUnt	Error count
ESECONDS	Errored seconds
PESECONDS	Percent errored seconds
UASECONDS	Unavailable seconds
PUASECONDS	Percent unavailable seconds
EFSECONDS	Error free seconds
PEFSECONDS	Percent error free seconds
SESECONDS	Severely errored seconds
PSESECONDS	Percent severely errored seconds
DMINutes	Degraded minutes
PDMINutes	Percent degraded minutes

**All percent measurements return NR3-numeric responses.**

**All other measurements return NR1-numeric responses.**

**Response** See Tables 2–31 and 2–32.

**Dependencies** These measurement queries can be sent at any time. However, if a test is currently running, the responses to the queries might not represent the final error measurements. After a test has been stopped or the test duration has expired, you can send these measurement queries again to get the final error measurements.

Do not set SENSE:DATA:TELEcom:TRIButary:PAYLoad:PATtern to UNKNown if you want to use these queries.

**Errors and Events** None

**Examples** See Table 2–33.

**Table 2–33: Example Table for SENSE:DATA:TELEcom:MEASure:TRIButary:ANALySis Queries (PDH)**

Query	Response
SENSE:DATA:TELECOM:MEASURE:TRIBUTARY:ANALYSIS:M2100:IN:UASECONDS?	23
SENSE:DATA:TELECOM:MEASURE:TRIBUTARY:ANALYSIS:M2100:OUT:PSESECONDS?	1.2E-1
SENSE:DATA:TELECOM:MEASURE:TRIBUTARY:ANALYSIS:G821:DMINUTES?	103

**Related Commands**    SENSE:DATA:TELEcom:TEST:STARt  
 SENSE:DATA:TELEcom:TEST:STOP  
 SENSE:DATA:TELEcom:TRIButary:PAYLoad:PATtern  
 SYSTem:HEADers

## SENSE:DATA:TELEcom:MEASure:TRIButary:ALARm Queries

Add/Drop Test Option Only

These queries return tributary alarm measurements. When you use the SENSE:DATA:TELEcom:MEASure:TRIButary:ALARm? query, it is helpful to turn the headers on (SYSTem:HEADers ON) so you can identify each response value in the response string.

**Syntax**    All valid queries are listed in the Syntax column of Table 2–34.

**Table 2–34: Syntax Table for SENSE:DATA:TELEcom:MEASure:TRIButary:ALARm Queries**

Syntax	Response
SENSE:DATA:TELEcom:MEASure:TRIButary:ALARm?	All tributary alarm measurements
SENSE:DATA:TELEcom:MEASure:TRIButary:ALARm:LOSignal?	Number of seconds of tributary Loss of Signal
SENSE:DATA:TELEcom:MEASure:TRIButary:ALARm:LOFrame?	Number of seconds of tributary Loss of Frame
SENSE:DATA:TELEcom:MEASure:TRIButary:ALARm:AIS?	Number of seconds of tributary AIS
SENSE:DATA:TELEcom:MEASure:TRIButary:ALARm:RAI?	Number of seconds of tributary RAI (PDH only)
SENSE:DATA:TELEcom:MEASure:TRIButary:ALARm:LOPS?	Number of seconds of loss of pattern sync

All responses are in NR1-numeric format.

**Response**    See the Response column of Table 2–34.

**Dependencies** These measurement queries can be sent at any time. However, if a test is currently running, the responses to the queries might not represent the final error measurements. After a test has been stopped or the test duration has expired, you can send these measurement queries again to get the final error measurements.

**Errors and Events** None

**Examples** See Table 2–35.

**Table 2–35: Example Table for SENSE:DATA:TELEcom:MEASure:TRIButary:ALARm Queries**

Query	Response
SENSE:DATA:TELECOM:MEASURE:TRIBUTARY:ALARM:LOSIGNAL?	20
SENSE:DATA:TELECOM:MEASURE:TRIBUTARY:ALARM:AIS?	13

**Related Commands** SENSE:DATA:TELEcom:TEST:START  
 SENSE:DATA:TELEcom:TEST:STOP  
 SENSE:DATA:TELEcom:TRIButary:PAYLoad:PATtern  
 SYSTem:HEADers

## SENSe:DATA:TELEcom:AUTOscan Subsystem

This section describes the command that automatically configures the receiver to the attached signal on any of the input connectors. Figure 2–44 shows the hierarchy tree for this subsystem.



Figure 2–44: SENSe:DATA:TELEcom:AUTOscan subsystem

## SENSe:DATA:TELEcom:AUTOscan

This command starts the autoscan function which sets up the receiver based on the connected signal. The Operation Complete bit is set when this command has completed. Use the SYSTem:ERRor? query to see if the autoscan completed successfully.

<b>Syntax</b>	SENSe:DATA:TELEcom:AUTOscan
<b>Parameters</b>	None
<b>Dependencies</b>	A valid signal should be connected.
<b>Errors and Events</b>	361, “Autoscan failed; Instrument returned to previous setup” 361, “Autoscan failed; Autoscan already in progress” 402, “Operation complete; Autoscan complete” 200, “Execution error; Autoscan incomplete — no signals connected”
<b>Examples</b>	SENSe:DATA:TELECOM:AUTOSCAN
<b>Related Commands</b>	SYSTem:ERRor?

## SENSe:DATA:TELEcom:TRIButary Subsystem

### Add/Drop Test Option Only

This section describes the commands and queries that allow you to view a dropped tributary signal. Figure 2–45 shows the hierarchy tree for this subsystem.

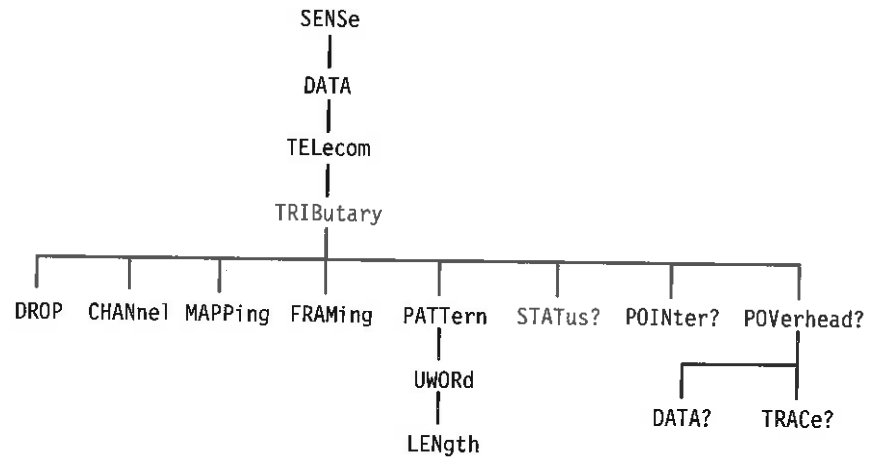

Figure 2–45: SENSE:DATA:TELEcom:TRIButary subsystem

**SENSe:DATA:TELEcom:TRIButary:DROP**

Add/Drop Test Option Only

This command sets or queries the tributary drop capability. If enabled, the demapped signal is available on the output connector specified by mapping. DS3\_DEMUX mapping drops a DS3 signal.

**Syntax** SENSE:DATA:TELEcom:TRIButary:DROP <trib drop>  
SENSe:DATA:TELEcom:TRIButary:DROP?

**Parameters**

<trib drop> (boolean)	Description
OFF or 0	Tributary signal not available on output connector (default)
ON or 1	Tributary signal available on output connector

**Dependencies**

SENSe:DATA:TELEcom:SOURce must be set to INPUT1.  
SENSe:DATA:TELEcom:MAPPING must be set to TRIButary.

**Errors and Events**

221, "Settings conflict; Instrument unable to drop signal while transmitting current rate"  
221, "Settings conflict"

**Examples**

Set: SENSE:DATA:TELECOM:TRIBUTARY:DROP ON  
Query: SENSE:DATA:TELECOM:TRIBUTARY:DROP?  
Response: 0

**Related Commands**

SOURce:DATA:TELEcom:SOURce  
SENSe:DATA:TELEcom:SOURce  
SENSe:DATA:TELEcom:MAPPING



## SENSe:DATA:TELEcom:TRIButary:CHANnel

Add/Drop Test Option Only

This command sets or queries the TUASYNC channel. Use the SENSe:DATA:TELEcom:TRIButary:MAPPING command to set the tributary demapping.

**Syntax** SENSe:DATA:TELEcom:TRIButary:CHANnel <trib channel>  
SENSe:DATA:TELEcom:TRIButary:CHANnel?

Parameters	<trib channel> (NR1-numeric)	Description
	Any integer between 1 and 63	TUASYNC mapping for the active channel (default = 1)
	Any integer between 1 and 3	TU3 mapping for the active channel
	1	M140 mapping for the active channel

**Dependencies** None

**Errors and Events** None

**Examples**  
Set: SENSe:DATA:TELECOM:TRIBUTARY:CHANNEL 1  
Query: SENSe:DATA:TELECOM:TRIBUTARY:CHANNEL?  
Response: 24

**Related Commands** SENSe:DATA:TELEcom:TRIButary:MAPPING

## SENSe:DATA:TELEcom:TRIButary:MAPPING

Add/Drop Test Option Only

This command sets or queries the tributary payload demapping. When you are actively mapping and demapping a tributary signal, the

SOURce:DATA:TELEcom:

TRIButary:MAPPING and SENSe:DATA:TELEcom:TRIButary:MAPPING

functions are coupled; a change to one causes the same change to the other.

**Syntax** SENSe:DATA:TELEcom:TRIButary:MAPPING <trib mapping>  
SENSe:DATA:TELEcom:TRIButary:MAPPING?

Parameters	<trib mapping> (discrete)	Description
	TUASync	Demapped 2 Mb/s signal into TU-12 floating async (default)
	TU3	Demapped 34 Mb/s signal
	M140	Demapped 140 Mb/s signal

**Dependencies** None

**Errors and Events** None

**Examples**  
Set:       SENSe:DATA:TELECOM:TRIBUTARY:MAPPING TUASync  
Query:     SENSe:DATA:TELECOM:TRIBUTARY:MAPPING?  
Response:  TU3

**Related Commands** SOURce:DATA:TELEcom:TRIButary:MAPPING

**SENSe:DATA:TELEcom:TRIButary:FRAMing**

Add/Drop Test Option Only

This command sets or queries the framing of the received tributary signal.

**Syntax** SENSE:DATA:TELEcom:TRIButary:FRAMing <trib framing>  
SENSe:DATA:TELEcom:TRIButary:FRAMing?

Parameters	<trib framing> (discrete)	Description
	UNFRamed	No framing (default)
	PCM30	2 Mb/s, PCM, 30 channels, no CRC checking
	PCM31	2 Mb/s, PCM, 31 channels, no CRC checking
	PCM30CRC	2 Mb/s, PCM, 30 channels, with CRC checking
	PCM31CRC	2 Mb/s, PCM 31 channels, with CRC checking
	FRAMED	34 Mb/s or 140 Mb/s framing

**Dependencies** For DS3\_DEMUX mapping only CBIT and M13 are allowed

**Errors and Events** None

**Examples**

Set: SENSE:DATA:TELECOM:TRIBUTARY:FRAMING UNFRAMED

Query: SENSE:DATA:TELECOM:TRIBUTARY:FRAMING?

Response: PCM31

**Related Commands** None

## SENSe:DATA:TELEcom:TRIButary:PATtern

Add/Drop Test Option Only

This command sets or queries the internally generated pattern that is placed in the tributary payload.

**Syntax** SENSE:DATA:TELEcom:TRIButary:PATtern <trib pattern>  
SENSe:DATA:TELEcom:TRIButary:PATtern?

Parameters	<trib pattern> (discrete)	Description
	PRBS23	A pseudo-random binary sequence of length $2^{23}-1$ is placed in the tributary payload (default)
	PRBS15	A pseudo-random binary sequence of length $2^{15}-1$ is placed in the tributary payload
	PRBS20	A pseudo-random binary sequence of length $2^{20}-1$ is placed in the tributary payload
	AZEROs	All zeros are placed in the payload
	AONEs	All ones are placed in the payload
	UWORD	A user-defined pattern is placed in the payload
	UNKNown	Unknown pattern
	FIXED_1_8	1 bit in 8 (Add/Drop Test Option Only)

**Dependencies** None

**Errors and Events** None

**Examples**  
Set: SENSE:DATA:TELECOM:TRIBUTARY:PATTERN PRBS15  
Query: SENSE:DATA:TELECOM:TRIBUTARY:PATTERN?  
Response: PRBS20

**Related Commands** None

## SENSe:DATA:TELecom:TRIButary:PATtern:UWORD

Add/Drop Test Option Only

This command sets or queries the user-defined pattern that is placed in the tributary payload.

**Syntax** SENSE:DATA:TELecom:TRIButary:PATtern:UWORD <trib user pattern>  
SENSe:DATA:TELecom:TRIButary:PATtern:UWORD?

Parameters	<trib user pattern> (hexadecimal)	Description
	Any 8, 16, or 24 bit hexadecimal number in the range #H00 to #HFFFFFF	Repeating pattern is placed in the tributary payload (default = #H00)

**Dependencies** SENSE:DATA:TELecom:TRIButary:PATtern must be set to UWORD for this command to apply. Use the SENSE:DATA:TELecom:TRIButary:PATtern:UWORD:LENgth command to set the length of the repeating pattern.

**Errors and Events** None

**Examples**

Set: SENSE:DATA:TELECOM:TRIBUTARY:PATTERN:UWORD #HAA5500

Query: SENSE:DATA:TELECOM:TRIBUTARY:PATTERN:UWORD?

Response: #HAA5500

**Related Commands** SENSE:DATA:TELecom:TRIButary:PATtern  
SENSe:DATA:TELecom:TRIButary:PATtern:UWORD:LENgth

## SENSe:DATA:TELEcom:TRIButary:PATtern:UWORD:LENGth

Add/Drop Test Option Only

This command sets or queries the number of bytes of the user-defined pattern that are repeated in the tributary payload.

**Syntax** SENSe:DATA:TELEcom:TRIButary:PATtern:UWORD:LENGth <trib user pattern length>

**Parameters**

<trib user pattern length> (NR1-numeric)	Description
Any integer in the range 1 to 3	Number of bytes of user-defined pattern that are repeated in the tributary payload (default = 1)

**Dependencies** SENSe:DATA:TELEcom:TRIButary:PATtern must be set to UWORD for this command to apply. Use the SENSe:DATA:TELEcom:TRIButary:PATtern:UWORD command to set the repeating pattern.

**Errors and Events** None

**Examples**  
 Set:       SENSe:DATA:TELECOM:TRIBUTARY:PATTERN:UWORD:LENGTH 3  
 Query:     SENSe:DATA:TELECOM:TRIBUTARY:PATTERN:UWORD:LENGTH?  
 Response:  2

**Related Commands** SENSe:DATA:TELEcom:TRIButary:PATtern  
 SENSe:DATA:TELEcom:TRIButary:PATtern:UWORD

**SENSe:DATA:TELEcom:TRIButary:POINter?**

Add/Drop Test Option Only

This query returns the current tributary pointer value.

**Syntax** SENSE:DATA:TELEcom:TRIButary:POINter?

Response	<trib pointer> (NR1-numeric)	Description
	Any integer in the range 0 to 1023	Tributary pointer value for TUASYNC mapping (default = 105, illegal > 139) Tributary pointer value for TU3 mapping (default = 595, illegal > 764)

**Dependencies** None**Errors and Events** None**Examples** Query: SENSE:DATA:TELECOM:TRIBUTARY:POINTER?

Response: 12

**Related Commands** None**SENSe:DATA:TELEcom:TRIButary:STATus?**

Add/Drop Test Option Only

This query returns the status of the received tributary signal. The returned status is not an accumulated status; the response reflects only the status of the tributary signal at the time the query is sent.

**Syntax** SENSe:DATA:TELEcom:TRIButary:STATus?

<b>Response</b>	<b>&lt;decimal value&gt; (NR1-numeric)</b>	<b>bit</b>	<b>definition</b>
	1	0	INPUT2/INPUT3 LOS
	2	1	INPUT2/INPUT3 LOF
	4	2	Unused
	8	3	Unused
	16	4	TU LOP
	32	5	TU AIS
	64	6	2 Mb/s, 34 Mb/s, 140 Mb/s AIS
	128	7	2 Mb/s, 34 Mb/s, 140 Mb/s RAI
	256	8	Frame error
	512	9	2 Mb/s, 34 Mb/s, 140 Mb/s error
	1024	10	TU FERF
	2048	11	TU pointer adjustment
	4096	12	TU NDF
	8192	13	Pattern lock
	16384	14	Not used
	32768	15	TU LOM

**Dependencies** None

**Errors and Events** None

**Examples** Query: SENSE:DATA:TELECOM:TRIBUTARY:STATUS?  
Response: 32

**Related Commands** SENSE:DATA:TELECOM:TRIBUTARY:STATUS



**SENSe:DATA:TELEcom:TRIButary:POVerhead:DATA?**

This query returns the value in the specified TU3 or TU12 path overhead byte.

**Syntax** SENSE:DATA:TELEcom:TRIButary:POVerhead:DATA? <byte name>

Parameters	<byte> (discrete)	Description
	C2	Signal label (TU3)
	F2	User channel (TU3)
	H4	Indicator (TU3)
	F3	Growth bytes (TU3)
	K3	(TU3)
	K4	(TU12)
	N1	(TU3)
	N2	(TU12)
	V5	(TU12)

Response	<value> (NR1-numeric)	Description
	Any integer in the range 0 to 255	The selected byte is set to this value

**Dependencies** Use the SENSE:DATA:TELEcom:TRIButary:CHANNEL command to specify which path trace to query. INITiate and TRIGGER:IMMEDIATE affect these bytes.

**Errors and Events** None

**Examples**  
 Query: SENSE:DATA:TELECOM:TRIBUTARY:POVERHEAD:DATA? V5  
 Response: 123

**Related Commands**  
 INITiate  
 TRIGGER:IMMEDIATE

## SENSe:DATA:TELEcom:TRIButary:POVerhead:TRACe?

This query returns the current tributary path trace string that repeats in the J1 byte, for TU3 mapping, and the J2 byte, for TU12 mapping, as a 16 character repeating sequence. The response is created in the following way: the first character after a null is read as the first byte and is followed by 15 J1/J2 bytes from consecutive frames.

**Syntax** SENSe:DATA:TELEcom:TRIButary:POVerhead:TRACe?

Response	<path trace> (string)	Description
	A 16 character string	The current tributary path trace string

**Dependencies** The SENSe:DATA:TELEcom:CHANnel command specifies which path trace to query.

**Errors and Events** None

**Examples**  
 Query: SENSe:DATA:TELECOM:TRIBUTARY:POVERHEAD:TRACE?  
 Response: "TEK CTS750"

**Related Commands**  
 SENSe:DATA:TELEcom:TRIButary:POVerhead:DATA?  
 INITiate  
 TRIGger:IMMediate

## SENSe:DATA:TELEcom:JITter Subsystem

This section describes the commands and queries that control the jitter and wander measurements. Figure 2-46 shows the hierarchy tree for this subsystem.

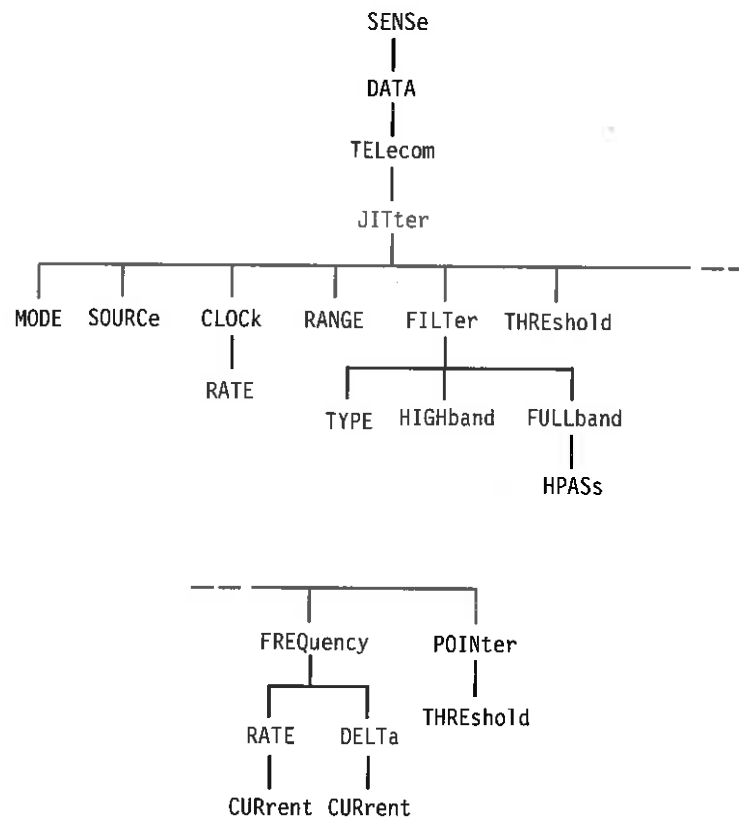

Figure 2-46: SENSE:DATA:TELEcom:JITter subsystem

## SENSe:DATA:TELEcom:JITter:MODE

SDH/PDH Jitter/Wander Test Option Only

This command sets or queries the jitter/wander generation mode.

**Syntax** SENSE:DATA:TELEcom:JITter:MODE <jitter mode>  
SENSe:DATA:TELEcom:JITter:MODE?

Parameters	<jitter mode> (discrete)	Description
	PTPeak	Measure peak-to-peak jitter (default)
	RMS	Measure RMS jitter

**Dependencies** Requires installation of Option 14 jitter module.  
\*RST sets jitter mode to PTPeak (default).

**Errors and Events** None

**Examples**  
Set: SENSE:DATA:TELECOM:JITTER:MODE RMS  
Query: SENSE:DATA:TELECOM:JITTER:MODE?  
Response: PTPEAK

**Related Commands** None

**SENSe:DATA:TELEcom:JITter:SOURce**

SDH/PDH Jitter/Wander Test Option Only

This command sets or queries the jitter measurement source.

**Syntax**    SENSE:DATA:TELEcom:JITter:SOURce <jitter source>  
 SENSE:DATA:TELEcom:JITter:SOURce?

Parameters	<jitter source> (discrete)	Description
	LINE	Measure jitter on receive line signal (default)
	CLOCK	Measure jitter on the clock

**Dependencies**    Requires installation of Option 14 jitter module.  
 \*RST sets jitter source to LINE (default).

**Errors and Events**    None

**Examples**    Set:        SENSE:DATA:TELECOM:JITTER:SOURCE LINE  
 Query:     SENSE:DATA:TELECOM:JITTER:SOURCE?  
 Response:  CLOCK

**Related Commands**    None

**SENSe:DATA:TELEcom:JITter:CLOCK:RATE**

SDH/PDH Jitter/Wander Test Option Only

This command sets or queries the jitter or wander receive clock rate.

**Syntax** SENSe:DATA:TELEcom:JITter:CLOCK:RATE <clock rate>**Parameters**

<clock rate> (discrete)	Description
M52	52 Mb/s rate
M155	155 Mb/s rate
M622	622 Mb/s rate
M2	2 Mb/s rate (default)
M34	34 Mb/s rate
M140	140 Mb/s rate

**Dependencies** Requires installation of Option 14 jitter module.

\*RST sets the clock rate to M52 (default).

**Errors and Events** None**Examples** Set: SENSe:DATA:TELECOM:JITTER:CLOCK:RATE M2

Query: SENSe:DATA:TELECOM:JITTER:CLOCK:RATE?

Response: M155

**Related Commands** None**SENSe:DATA:TELEcom:JITter:RANGe**

SDH/PDH Jitter/Wander Test Option Only

This command sets or queries the jitter measurement amplitude range. The entered value is the maximum UI that can be measured within the range.

**Syntax** SENSe:DATA:TELEcom:JITter:RANGe <jitter range>  
SENSe:DATA:TELEcom:JITter:RANGe?

Parameters	<jitter range> (discrete)	Description
	NORMAL	Normal range 0–6 UI (default)
	EXTENDED	Extended range 0–16 or 0–200 UI. The instrument selects range based on jitter source rate: <ul style="list-style-type: none"> <li>■ 0 Hz to 30 Hz the maximum amplitude is 200</li> <li>■ 30 Hz to 375 Hz the maximum amplitude drops linearly from 200 to 16</li> <li>■ 375 Hz to the filter cutoff the maximum amplitude stays at 16</li> </ul>

**Dependencies** Requires installation of Option 14 jitter module.  
\*RST sets the jitter range to NORMAL (default).

**Errors and Events** None

**Examples**  
Set: SENSE:DATA:TELECOM:JITTER:RANGE NORMAL  
Query: SENSE:DATA:TELECOM:JITTER:RANGE?  
Response: EXTENDED

**Related Commands** None

## SENSe:DATA:TELEcom:JITter:FILTer:TYPE

SDH/PDH Jitter/Wander Test Option Only

This command sets or queries the input signal jitter filter.

**Syntax** SENSe:DATA:TELEcom:JITter:FILTer:TYPE <jitter filter>  
SENSe:DATA:TELEcom:JITter:FILTer:TYPE?

Parameters	<jitter filter> (discrete)	Description
	WIDEBand	Input filter (default)
	HIGHBand	Input filter
	FULLband	Tektronix-defined input filter

**Dependencies** Requires installation of Option 14 jitter module.

The frequency range for each filter type is defined by the standards. Frequency ranges also vary depending on the clock rate.

\*RST sets the jitter filter type to WIDEband (default).

**Errors and Events** None

**Examples**

Set: SENSE:DATA:TELECOM:JITTER:FILTER:TYPE HIGHBAND

Query: SENSE:DATA:TELECOM:JITTER:FILTER:TYPE?

Response: HIGHBAND

**Related Commands** None

## SENSe:DATA:TELEcom:JITter:FILTer:HIGHBand

SDH/PDH Jitter/Wander Test Option Only

This command sets or queries the highband jitter filter mask.

**Syntax** SENSe:DATA:TELEcom:JITter:FILTer:HIGHBand <select Q>  
SENSe:DATA:TELEcom:JITter:FILTer:HIGHBand?

Parameters	<select Q> (discrete)	Description
	STANDard	Standards-defined mask (valid for all but 2MB; default for all but 2MB)
	LOWQ	LOWQ mask (valid for 2MB; default for 2MB)
	HIGHQ	HIGHQ mask (valid for 2MB)

**Dependencies** Requires installation of Option 14 jitter module.

\*RST sets select Q to STANDard.

**Errors and Events** 221, "Settings conflict"  
if the entered value is incorrect for the current receive rate.



**Examples** Set: SENSE:DATA:TELECOM:JITTER:FILTER:HIGHBAND LOWQ  
 Query: SENSE:DATA:TELECOM:JITTER:FILTER:HIGHBAND?  
 Response: STANDARD

**Related Commands** NONE

## SENSe:DATA:TELEcom:JITter:FILTer:FULLband:HPASs

SDH/PDH Jitter/Wander Test Option Only

This command sets or queries the fullband filter's high-pass filter range.

**Syntax** SENSE:DATA:TELEcom:JITter:FILTer:FULLband:HPASs <fullband hpass>  
 SENSE:DATA:TELEcom:JITter:FILTer:FULLband:HPASs?

**Parameters**

<fullband hpass> (discrete)	Description
U_1	0.1 Hz (default)
U1	1 Hz
U10	10 Hz

**Dependencies** Requires installation of Option 14 jitter module.  
 \*RST sets fullband hpass to U\_1 (default).

**Errors and Events** None

**Examples** Set: SENSE:DATA:TELECOM:JITTER:FILTER:FULLBAND:HPASS U1  
 Query: SENSE:DATA:TELECOM:JITTER:FILTER:FULLBAND:HPASS?  
 Response: U1

**Related Commands** None

## SENSe:DATA:TELEcom:JITter:THREShold

SDH/PDH Jitter/Wander Test Option Only

This command sets or queries the jitter hit threshold value.

**Syntax**      SENSE:DATA:TELEcom:JITter:THREShold <jitter threshold>  
 SENSE:DATA:TELEcom:JITter:THREShold?

Parameters	<jitter threshold> (NR3-numeric)	Description
	0-200	Threshold hit, in UI (default is 0.00)

**Dependencies**      Requires installation of Option 14 jitter module.

\*RST sets jitter threshold to 0.00 (default).

**Errors and Events**      500, "Execution warning"  
 if the entered value is out of range for the command.

**Examples**      Set:            SENSE:DATA:TELECOM:JITTER:THRESHOLD 12.5  
 Query:        SENSE:DATA:TELECOM:JITTER:THRESHOLD?  
 Response:    15.5

**Related Commands**      None

## SENSe:DATA:TELEcom:JITter:FREQuency:RATE:CURrent?

SDH/PDH Jitter/Wander Test Option Only

This query returns the receive rate frequency. This status is always available.

**Syntax**      SENSE:DATA:TELEcom:JITter:FREQuency:RATE:CURrent?

Response	<frequency rate> (NR3-numeric)	Description
	0~622 MHz	Receive rate frequency, in Hz

<b>Dependencies</b>	None
<b>Errors and Events</b>	None
<b>Examples</b>	Query: SENSE:DATA:TELECOM:JITTER:FREQUENCY:RATE:CURRENT? Response: 139.264E+6
<b>Related Commands</b>	None

## SENSE:DATA:TELEcom:JITter:FREQUency:DELTA:CURrent?

SDH/PDH Jitter/Wander Test Option Only

This query returns the difference between the receive rate and an ideal frequency. This status is always available.

**Syntax** SENSE:DATA:TELEcom:JITter:FREQUency:DELTA:CURrent?

Response	<frequency DELTA> (NR3-numeric)	Description
	-100.0 to 100.0	Delta frequency in ppm. Resolution is 0.01 ppm.

<b>Dependencies</b>	None
<b>Errors and Events</b>	None
<b>Examples</b>	Query: SENSE:DATA:TELECOM:JITTER:FREQUENCY:DELTA:CURRENT? Response: 10.01
<b>Related Commands</b>	None

## SENSe:DATA:TELEcom:JITter:POINter:THREShold

SDH/PDH Jitter/Wander Test Option Only

This command sets or queries the pointer hit threshold value. This value is the absolute allowable frequency drift rate. A pointer hit second event is recorded if the positive or negative frequency drift rate exceeds the pointer threshold value during a one second period.

**Syntax**      SENSE:DATA:TELEcom:JITter:POINter:THREShold <jitter threshold>  
 SENSE:DATA:TELEcom:JITter:POINter:THREShold?

Parameters	<jitter threshold> (NR3-numeric)	Description
	0-10	Pointer threshold in ppm/sec (default is 10)

**Dependencies**      Requires installation of Option 14 jitter module.

\*RST sets jitter threshold to 10 (default).

**Errors and Events**      500, "Execution warning"  
 if the entered value is out of range for the command.

**Examples**

Set:            SENSE:DATA:TELECOM:JITTER:POINTER:THRESHOLD 0.5

Query:        SENSE:DATA:TELECOM:JITTER:POINTER:THRESHOLD?

Response:    5

**Related Commands**      SENSE:DATA:TELEcom:MEASure:JITter:POINter:HSEConds?

# Transmitter/Receiver Setup Commands

The Transmitter/Receiver Setup Commands allow you to control the interaction between transmitter and Receiver settings. This section contains all of the commands and queries for the following transmitter/Receiver Setup subsystem:

- INSTRument

## INSTRument Subsystem

This section describes the command and query that control the coupling between the transmitter and Receiver setups. Figure 2–47 shows the hierarchy tree for this subsystem.

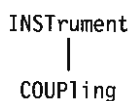

Figure 2–47: INSTRument:COUPLing Subsystem

## INSTRument:COUPLing

This command sets or queries the transmitter and Receiver setup coupling. NONE allows the transmitter and Receiver to be independently controlled. TXRX establishes interaction between the transmitter and Receiver parameters shown in

Table 2–36 with the transmitter governing the *initial* Receiver setup. RXTX establishes interaction between the transmitter and Receiver parameters shown in Table 2–36 with the Receiver governing the *initial* transmitter setup.

Table 2–36: Parameters interacting through instrument coupling

Receiver	Transmitter
INPUT1:RATE	OUTPUT1:RATE
INPUT1:TYPE	OUTPUT1:TYPE
SENSE:DATA:TELEcom:SOURce	SOURce:DATA:TELEcom:SOURce
SENSE:DATA:TELEcom:CHANnel	SOURce:DATA:TELEcom:CHANnel
SENSE:DATA:TELEcom:PAYLoad:MAPPing	SOURce:DATA:TELEcom:PAYLoad:MAPPing
SENSE:DATA:TELEcom:PAYLoad:PATTern	SOURce:DATA:TELEcom:PAYLoad:PATTern
SENSE:DATA:TELEcom:PAYLoad:UBYTE	SOURce:DATA:TELEcom:PAYLoad:UBYTE

**NOTE.** A change to one of the parameters listed in Table 2–36 might cause a change to the INSTRUMENT:COUPLing parameter value. For example, if you set INSTRUMENT:COUPLing to TXRX then change OUTPUT1:RATE, the value of INSTRUMENT:COUPLing is changed to RXTX.

---

**Syntax** INSTRUMENT:COUPLing <coupling>  
 INSTRUMENT:COUPLing?

**Parameters**

<coupling> (discrete)	description
NONE	Setups are independent
TXRX	transmitter sets initial condition of the Receiver
RXTX	Receiver sets initial condition of the transmitter

**Dependencies** None

**Errors and Events** None

**Examples**  
 Set: INSTRUMENT:COUPLING TXRX  
 Query: INSTRUMENT:COUPLING?  
 Response: RXTX

**Related Commands** None

# Trigger and Capture Commands

The Trigger and Capture commands allow you to capture overhead and payload data. This section contains all of the commands and queries for the Trigger and Capture subsystem:

- INITiate
- TRIGger

## TRIGger Subsystem

This section describes each of the commands and queries that allow you to arm the trigger system and force an immediate trigger. Figure 2-48 shows the hierarchy tree for this subsystem.

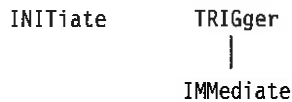

Figure 2-48: TRIGger subsystem

## INITiate

This command causes the capture mechanism to start and the trigger system to arm. After receiving this command, the instrument will acquire data until the programmed trigger event occurs or the capture is stopped manually with the TRIGger:IMMediate command.

<b>Syntax</b>	INITiate
<b>Parameters</b>	None
<b>Dependencies</b>	None
<b>Errors and Events</b>	None

<b>Examples</b>	INITIATE
<b>Related Commands</b>	TRIGger:IMMediate SENSe:DATA:TELEcom:OVERhead:DATA? SENSe:DATA:TELEcom:POVerhead:DATA?

## TRIGger:IMMediate

This command forces a trigger to occur, which stops the capture of data.

<b>Syntax</b>	TRIGger:IMMediate
<b>Parameters</b>	None
<b>Dependencies</b>	Before the TRIGger:IMMediate command is sent, an INITiate command must be sent first to arm the trigger system.
<b>Errors and Events</b>	None
<b>Examples</b>	TRIGGER:IMMEDIATE
<b>Related Commands</b>	INITiate SENSe:DATA:TELEcom:OVERhead:DATA? SENSe:DATA:TELEcom:POVerhead:DATA?



## TRIGger:STATus?

SDH/PDH Jitter/Wander Test Option Only

This query returns the instrument trigger status.

**Syntax** TRIGger:STATus?

**Response**

<frequency rate> (NR3-numeric)	Description
RUN	Instrument is waiting for a trigger
STOP	Instrument has been triggered

**Dependencies** None

**Errors and Events** None

**Examples** Query: TRIGger:STATus?

Response: STOP

**Related Commands** TRIGger:IMMediate



# Input/Output Commands

The Input/Output commands allow you to write files to disk, control the display of the instrument, print reports, and communicate with the instrument over an RS-232 port. This section contains all of the commands and queries for each of the following Input/Output subsystems:

- MMEMory
- DISPlay
- HCOPy
- SYSTem:COMMunicate:SERial

## MMEMory Subsystem

This section describes each of the commands and queries that control access to the disk. Figure 2–49 shows the hierarchy tree for this subsystem. All MMEMory commands set the OPC bit in the Standard Event Status Register.

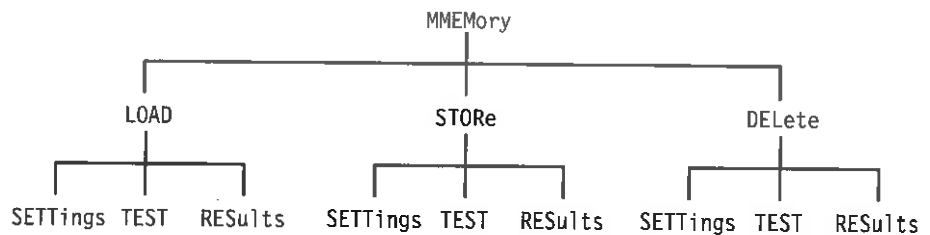

**Figure 2–49: MMEMory subsystem**

---

**NOTE.** Do not specify the file name extension for any of these commands. Extensions are added automatically by the system.

---

## MMEMory:STORe:SETTings

This command stores the current instrument state or stored setups to a disk file.

**Syntax** MMEMory:STORe:SETTings <file name>,<buffer>

Parameters	<file name> (string)	Description
	A maximum of eight characters in the form "file name"	File name you want to save the setups to; the extension ".SET" is added by the software.
Parameters	<buffer> (NR1-numeric)	Description
	Valid values are 0 through 5	Buffer 0 contains the current setups, buffers 1 through 5 contain the previous setups

**Dependencies** A disk must be in the disk drive.

**Errors and Events** 402, "Operation complete; Save of instrument setup complete"  
 252, "Missing media; Disk not present in drive"  
 254, "Media full; Disk is full"  
 257, "File name error; File name required"  
 258, "Media protected; Disk is write-protected, cannot write to file"

**Examples** MMEMORY:STORe:SETTings "TEMP0001",1

**Related Commands** \*SAV

## MMEMory:DELEte:SETTings

This command deletes a setup file from the disk.

**Syntax** MMEMory:DELEte:SETTings <file name>

Parameters	<file name> (string)	Description
	A maximum of eight characters in the form "file name"	Name of the setups file you want deleted

<b>Dependencies</b>	A disk must be in the disk drive.
<b>Errors and Events</b>	252, "Missing media; Disk not present in drive" 256, "File name not found; Could not open disk file" 258, "Media protected; Disk is write-protected, cannot write to file"
<b>Examples</b>	MMEMORY:DELETE:SETTINGS "FILEONE"
<b>Related Commands</b>	None

## MMEMory:LOAD:SETTings

This command restores the instrument state from a disk file into a stored setup location (buffers 1 through 5) or the current instrument state (buffer 0). Once settings have been loaded into one of the stored setup buffers (buffers 1 through 5), you can give a \*RCL command to place them into buffer 0 (current instrument state).

**Syntax** MMEMory:LOAD:SETTings <file name>, <buffer>

<b>Parameters</b>	<file name> (string)	Description
		A maximum of eight characters in the form "file name"
	<buffer> (NR1-numeric)	Description
		Valid values are 0 through 5

<b>Dependencies</b>	A disk must be in the disk drive.
<b>Errors and Events</b>	402, "Operation complete; Recall of instrument setup complete" 252, "Missing media; Disk not present in drive"
<b>Examples</b>	MMEMORY:LOAD:SETTINGS "TEMP001",0
<b>Related Commands</b>	*RCL

## MMEMory:STORe:TEST

This command stores the current instrument test to a disk file.

**Syntax** MMEMory:STORe:TEST <file name>

Parameters	<file name> (string)	Description
	A maximum of eight characters in the form "file name"	File name you want to save the test to; the extension ".TST" is added by the software

**Dependencies** A disk must be in the disk drive.

**Errors and Events**

- 252, "Missing media; Disk not present in drive"
- 254, "Media full; Disk is full"
- 257, "File name error; File name required"
- 258, "Media protected; Disk is write-protected, cannot write to file"

**Examples** MMEMORY:STORe:TEST "TEMP0001"

**Related Commands** \*SAV

## MMEMory:DELEte:TEST

This command deletes a test file from the disk.

**Syntax** MMEMory:DELEte:TEST <file name>

Parameters	<file name> (string)	Description
	A maximum of eight characters in the form "file name"	Name of the test file you want deleted

**Dependencies** A disk must be in the disk drive.

**Errors and Events**

- 252, "Missing media; Disk not present in drive"
- 256, "File name not found; Could not open disk file"
- 258, "Media protected; Disk is write-protected, cannot write to file"

**Examples**     MMEMORY:DELETE:TEST "FILEONE"

**Related Commands**     None

## MMEMory:LOAD:TEST

This command restores a test from a disk file into the current instrument test (buffer 0).

**Syntax**     MMEMory:LOAD:TEST <file name>

Parameters	<file name> (string)	Description
	A maximum of eight characters in the form "file name"	File name you want to load the test from

**Dependencies**     Disk must be in the disk drive.

**Errors and Events**     252, "Missing media; Disk not present in drive"

**Examples**     MMEMORY:LOAD:TEST "TEMP0001"

**Related Commands**     \*RCL

## MMEMoRY:SToRe:RESuLts

This command stores the current or stored test results to a disk file. If the current test results are of great length, only buffer number 1 may be available to store to disk. Use the SENSE:DATA:TELEcom:MEASurement:BUFFer:AVAILable? query to determine if buffer 2 exists.

**Syntax** MMEMoRY:SToRe:RESuLts <file name>,<buffer>

Parameters	<file name> (string)	Description
		A maximum of eight characters in the form "file name"
	<buffer> (NR1-numeric)	Description
	Valid values are 1 and 2	Buffer 1 contains the current test results; buffer 2 contains the previous test results

**Dependencies** A disk must be in the disk drive.

**Errors and Events** 252, "Missing media; Disk not present in drive"  
 254, "Media full; Disk is full"  
 257, "File name error; File name required"  
 258, "Media protected; Disk is write-protected, cannot write to file"

**Examples** MMEMoRY:SToRe:RESuLts "TEMP0001",1

**Related Commands** \*SAV



## MMEMory:DELEte:RESuLts

This command deletes a test results file from the disk.

**Syntax** MMEMory:DELEte:RESuLts <file name>

Parameters	<file name> (string)	Description
	A maximum of eight characters in the form "file name"	Name of the test results file you want deleted

**Dependencies** A disk must be in the disk drive.

**Errors and Events** 252, "Missing media; Disk not present in drive"  
256, "File name not found; Could not open disk file"  
258, "Media protected; Disk is write-protected, cannot write to file"

**Examples** MMEMORY:DELETE:RESULTS "FILEONE"

**Related Commands** None

## MMEMemory:LOAD:RESuLts

This command restores the instrument state from a disk file into a read only buffer (buffer number -1).

**Syntax** MMEMemory:LOAD:RESuLts <file name>

**Parameters**

<file name> (string)	Description
A maximum of eight characters in the form "file name"	File name you want to load the test results from

**Dependencies** Disk must be in the disk drive.

**Errors and Events** 252, "Missing media; Disk not present in drive"

**Examples** MMEMemory:LOAD:RESULTS "TEMP0001"

**Related Commands** \*RCL

## MMEMory:JITter Subsystem

This section describes each of the commands and queries that let you load, store, and delete floppy disk jitter data. Figure 2–50 shows the hierarchy tree for this subsystem. All MMEMory commands set the OPC bit in the Standard Event Status Register.

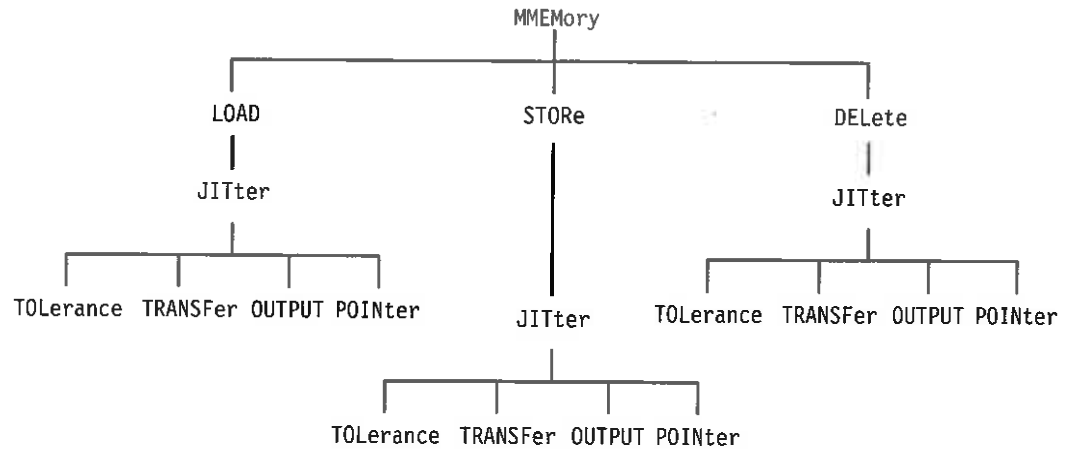

Figure 2–50: MMEMory:JITter subsystem

**NOTE.** Do not specify a file name extension for any of these commands. Extensions are added automatically by the system.

## MMEMory:LOAD:JITter:TOLerance

SDH/PDH Jitter/Wander Test Option Only

This command restores jitter tolerance test data from a disk file into a view-only compliance test page. Jitter tolerance files use the extension .JTL.

**Syntax** MMEMory:LOAD:JITter:TOLerance <filename>

**Parameters**

<filename> (string)	Description
1–8 characters	File name

- Dependencies** Requires installation of Option 14 jitter module.  
Disk must be in disk drive.
- Errors and Events** 252, "Missing media; Disk not present in drive"
- Examples** `MMEMemory:LOAD:JITTER:TOLERANCE "JTOL0001"`
- Related Commands** `MMEMemory:STORE:JITTER:TOLERANCE`

## MMEMemory:LOAD:JITTER:TRANSFER

SDH/PDH Jitter/Wander Test Option Only

This command restores jitter transfer test data from a disk file into a view-only compliance test page. Jitter transfer files use the extension .JTR.

**Syntax** `MMEMemory:LOAD:JITTER:TRANSFER <filename>`

Parameters	<filename> (string)	Description
	1-8 characters	File name

- Dependencies** Requires installation of Option 14 jitter module.  
Disk must be in disk drive.
- Errors and Events** 252, "Missing media; Disk not present in drive"
- Examples** `MMEMemory:LOAD:JITTER:TRANSFER "TRAN0001"`
- Related Commands** `MMEMemory:STORE:JITTER:TRANSFER`

## MMEMemory:LOAD:JITter:OUTPUT

SDH/PDH Jitter/Wander Test Option Only

This command restores jitter output test data from a disk file into a view-only compliance test page. Jitter output files use the extension .OUT.

**Syntax** MMEMemory:LOAD:JITter:OUTPUT <filename>

Parameters	<filename> (string)	Description
	1–8 characters	File name

**Dependencies** Requires installation of Option 14 jitter module.  
Disk must be in disk drive.

**Errors and Events** 252, “Missing media; Disk not present in drive”

**Examples** MMEMemory:LOAD:JITTER:OUTPUT "OUT0001"

**Related Commands** MMEMemory:STORe:JITter:OUTPUT

## MMEMemory:LOAD:JITter:POINter

SDH/PDH Jitter/Wander Test Option Only

This command restores jitter pointer test data from a disk file into a view-only compliance test page. Jitter pointer files use the extension .PTR.

**Syntax** MMEMemory:LOAD:JITter:POINter <filename>

Parameters	<filename> (string)	Description
	1–8 characters	File name

**Dependencies** Requires installation of Option 14 jitter module.  
Disk must be in disk drive.

**Errors and Events** 252, "Missing media; Disk not present in drive"

**Examples** MMEORY:LOAD:JITTER:POINTER "PTR0001"

**Related Commands** MMEORY:STORE:JITTER:POINTER

## MMEORY:STORE:JITTER:TOLERANCE

SDH/PDH Jitter/Wander Test Option Only

This command writes jitter tolerance test data to a disk file. Jitter tolerance files use the extension .JTL and .XTL. .XTL files contain the test data in a comma-separated format for use with spreadsheet programs.

**Syntax** MMEORY:STORE:JITTER:TOLERANCE <filename>

**Parameters**

<filename> (string)	Description
1-8 characters	File name

**Dependencies** Requires installation of Option 14 jitter module.

Disk must be in disk drive.

There must be room on the disk to store the file.

**Errors and Events** 252, "Missing media; Disk not present in drive"

254, "Media full; Disk is full"

257, "File name error; File name required"

258, "Media protected; Disk is write-protected, cannot write to file"

**Examples** MMEORY:STORE:JITTER:TOLERANCE "JTOL0001"

**Related Commands** MMEORY:LOAD:JITTER:TOLERANCE

## MMEMemory:STORE:JITter:TRANSFer

SDH/PDH Jitter/Wander Test Option Only

This command writes jitter transfer test data to a disk file. Jitter transfer files use the extensions .JTR and .XTR. .XTR files contain the test data in a comma-separated format for use with spreadsheet programs.

**Syntax** MMEMemory:STORE:JITter:TRANSFer <filename>

Parameters	<filename> (string)	Description
	1-8 characters	File name

**Dependencies** Requires installation of Option 14 jitter module.  
Disk must be in disk drive.  
There must be room on the disk to store the file.

**Errors and Events** 252, "Missing media; Disk not present in drive"  
254, "Media full; Disk is full"  
257, "File name error; File name required"  
258, "Media protected; Disk is write-protected, cannot write to file"

**Examples** MMEMemory:STORE:JITTER:TRANSFER "TRAN0001"

**Related Commands** MMEMemory:LOAD:JITter:TRANSFer

## MMEMory:STORe:JITter:OUTPUT

SDH/PDH Jitter/Wander Test Option Only

This command writes jitter output test data to a disk file. Jitter output files use the extension .OUT.

**Syntax** MMEMory:STORe:JITter:OUTPUT <filename>

Parameters	<filename> (string)	Description
	1-8 characters	File name

**Dependencies** Requires installation of Option 14 jitter module.  
 Disk must be in disk drive.  
 There must be room on the disk to store the file.

**Errors and Events** 252, "Missing media; Disk not present in drive"  
 254, "Media full; Disk is full"  
 257, "File name error; File name required"  
 258, "Media protected; Disk is write-protected, cannot write to file"

**Examples** MMEMORY:STORE:JITTER:OUTPUT "TRAN0001"

**Related Commands** MMEMory:LOAD:JITter:OUTPUT



## MMEMemory:STORE:JITter:POINter

SDH/PDH Jitter/Wander Test Option Only

This command writes jitter pointer test data to a disk file. Jitter pointer files use the extension .PTR.

**Syntax** MMEMemory:STORE:JITter:POINter <filename>

Parameters	<filename> (string)	Description
	1–8 characters	File name

**Dependencies** Requires installation of Option 14 jitter module.  
Disk must be in disk drive.  
There must be room on the disk to store the file.

**Errors and Events** 252, "Missing media; Disk not present in drive"  
254, "Media full; Disk is full"  
257, "File name error; File name required"  
258, "Media protected; Disk is write-protected, cannot write to file"

**Examples** MMEMemory:STORE:JITTER:POINter "PTR0001"

**Related Commands** MMEMemory:LOAD:JITter:POINter

## MMEMory:DELEte:JITter:TOLerance

SDH/PDH Jitter/Wander Test Option Only

This command removes a jitter tolerance test data file from a disk. Jitter tolerance files use the extension .JTL.

**Syntax** MMEMory:STORe:JITter:TOLerance <filename>

Parameters	<filename> (string)	Description
	1-8 characters	File name

**Dependencies** Requires installation of Option 14 jitter module.  
Disk must be in disk drive.

**Errors and Events** 252, "Missing media; Disk not present in drive"  
256, "File name not found; Could not open disk file"  
258, "Media protected; Disk is write-protected, cannot write to file"

**Examples** MMEMORY:STORE:JITTER:TOLERANCE "JTOL0001"

**Related Commands** MMEMory:LOAD:JITter:TOLerance

## MMEMory:DELEte:JITter:TRANSFer

SDH/PDH Jitter/Wander Test Option Only

This command removes a jitter transfer test data file from a disk. Jitter transfer files use the extension .JTL.

**Syntax** MMEMory:DELEte:JITter:TRANSFer <filename>

Parameters	<filename> (string)	Description
	1-8 characters	File name

<b>Dependencies</b>	Requires installation of Option 14 jitter module. Disk must be in disk drive.
<b>Errors and Events</b>	252, "Missing media; Disk not present in drive" 256, "File name not found; Could not open disk file" 258, "Media protected; Disk is write-protected, cannot write to file"
<b>Examples</b>	MMEMORY:DELETE:JITTER:TRANSFER "TRAN0001"
<b>Related Commands</b>	None

## MMEMory:DELEte:JITter:OUTPUT

SDH/PDH Jitter/Wander Test Option Only

This command removes a jitter output test data file from a disk. Jitter OUTPUT files use the extension .JTL.

**Syntax** MMEMory:DELEte:JITter:OUTPUT <filename>

<b>Parameters</b>	<filename> (string)	Description
	1-8 characters	File name

<b>Dependencies</b>	Requires installation of Option 14 jitter module. Disk must be in disk drive.
<b>Errors and Events</b>	252, "Missing media; Disk not present in drive" 256, "File name not found; Could not open disk file" 258, "Media protected; Disk is write-protected, cannot write to file"
<b>Examples</b>	MMEMORY:DELETE:JITTER:OUTPUT "OUT0001"
<b>Related Commands</b>	None

## MMEMemory:DELEte:JITter:POINter

SDH/PDH Jitter/Wander Test Option Only

This command removes a jitter pointer test data file from a disk. Jitter pointer files use the extension .PTR.

**Syntax** MMEMemory:DELEte:JITter:POINter <filename>

Parameters	<filename> (string)	Description
	1-8 characters	File name

**Dependencies** Requires installation of Option 14 jitter module.  
Disk must be in disk drive.

**Errors and Events** 252, "Missing media; Disk not present in drive"  
256, "File name not found; Could not open disk file"  
258, "Media protected; Disk is write-protected, cannot write to file"

**Examples** MMEMemory:DELETE:JITTER:POINTER "OUT0001"

**Related Commands** None

## DISPlay Subsystem

This section describes each of the commands and queries that control aspects of the front panel display. Figure 2–51 shows the hierarchy tree for this subsystem.

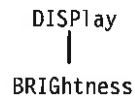

Figure 2–51: DISPlay subsystem

## DISPlay:BRIGhtness

This command sets or queries the display brightness.

**Syntax** DISPlay:BRIGhtness <display brightness>  
DISPlay:BRIGhtness?

Parameters	<display brightness> (NR3-numeric)	Description
	Any number between 0 and 1	0 indicates minimum brightness, 0.5 indicates medium brightness, and 1 indicates maximum brightness (default = 1.00)

**Dependencies** None

**Errors and Events** None

**Examples**

Set:        DISPLAY:BRIGhtNESS .8

Query:     DISPLAY:BRIGhtNESS?

Response:  0.75

**Related Commands** None

## HCOPY Subsystem

This section describes the commands and queries that control the printer. Figure 2–52 shows the hierarchy tree for this subsystem.

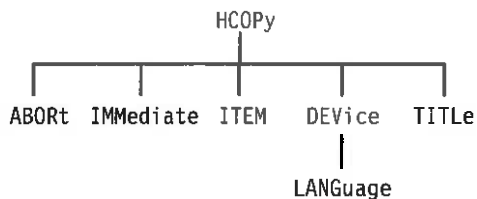

**Figure 2–52: HCOpy subsystem**

### HCOPY:ABORt

This command stops the current printout.

<b>Syntax</b>	HCOPY:ABORt
<b>Parameters</b>	None
<b>Dependencies</b>	None
<b>Errors and Events</b>	None
<b>Examples</b>	HCOPY:ABORT
<b>Related Commands</b>	HCOPY:IMMediate

## HCOPY:IMMEDIATE

This command starts the printout. The type of report to be printed is controlled with the HCOPIY:ITEM command. The OPC bit will be set when the report has printed.

<b>Syntax</b>	HCOPY:IMMEDIATE
<b>Parameters</b>	None
<b>Dependencies</b>	Your printer type must match the HCOPIY:DEVice:LANGUage setting
<b>Errors and Events</b>	402, "Operation complete; Hardcopy complete" 200, "Execution error; Hardcopy already in progress"
<b>Examples</b>	HCOPY:IMMEDIATE
<b>Related Commands</b>	HCOPY:ABORT

## HCOPY:ITEM

This command sets or queries the information to be printed.

<b>Syntax</b>	HCOPY:ITEM <hcopy item> HCOPY:ITEM?									
<b>Parameters</b>	<table border="1"> <thead> <tr> <th>&lt;hcopy item&gt; (discrete)</th> <th>Description</th> </tr> </thead> <tbody> <tr> <td>SUMMARY</td> <td>Summary of test results is printed (default)</td> </tr> <tr> <td>ALLRESULTS</td> <td>Summary of all measurement test results is printed</td> </tr> <tr> <td>SCREEN</td> <td>The current screen is printed</td> </tr> </tbody> </table>	<hcopy item> (discrete)	Description	SUMMARY	Summary of test results is printed (default)	ALLRESULTS	Summary of all measurement test results is printed	SCREEN	The current screen is printed	
<hcopy item> (discrete)	Description									
SUMMARY	Summary of test results is printed (default)									
ALLRESULTS	Summary of all measurement test results is printed									
SCREEN	The current screen is printed									
<b>Dependencies</b>	None									
<b>Errors and Events</b>	None									

**Examples**    Set:        HCOPIY:ITEM SUMMARY  
                   Query:      HCOPIY:ITEM?  
                   Response: SCREEN

**Related Commands**    HCOPIY:IMMEDIATE

## HCOPIY:DEVIce:LANGUage

This command sets or queries the printer language.

**Syntax**    HCOPIY:DEVIce:LANGUage <printer language>  
                   HCOPIY:DEVIce:LANGUage?

Parameters	<printer language> (discrete)	Description
	TEK	Tektronix DPU-411 printer (default)
	EPSON	Epson printer
	PCL	Printer Control Language (Hewlett-Packard Thinkjet)

**Dependencies**    None

**Errors and Events**    None

**Examples**    Set:        HCOPIY:DEVIce:LANGUage EPSON  
                   Query:      HCOPIY:DEVIce:LANGUage?  
                   Response: PCL

**Related Commands**    None



**HCOPY:TITLe**

This command sets or queries the title printing capability. If the HCOpy:TITLe is set to ON, the system owner and system user values will be printed as the title.

**Syntax** HCOpy:TITLe <title enabled>  
HCOpy:TITLe?

**Parameters**

<title enabled> (boolean)	Description
0 or OFF	Title not printed (default)
1 or ON	Title printed

**Dependencies** None

**Errors and Events** None

**Examples** Set: HCOpy:TITLe ON  
Query: HCOpy:TITLe?  
Response: 0

**Related Commands** None

## SYSTem:COMMunicate:SERial Subsystem

This section describes the commands and queries that control communication over the serial port. Figure 2–53 shows the hierarchy tree for this subsystem.

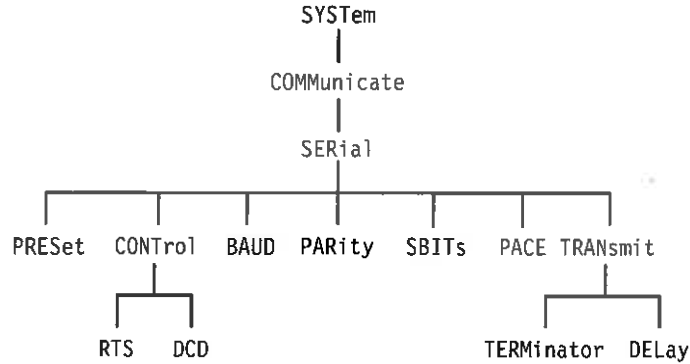

Figure 2–53: SYSTem:COMMunicate:SERial subsystem

## SYSTem:COMMunicate:SERial:PRESet

This command sets all parameters in the serial subsystem to default values.

**Syntax** SYSTem:COMMunicate:SERial:PRESet

**Parameters** There are no parameters for this command. The resulting defaults for each command are shown in Table 2–37.

Table 2–37: Commands and Default Values Set by the SYSTem:COMMunicate:SERial:PRESet Command

Command	Default value
SYSTem:COMMunicate:SERial:CONTRol:DCD	0
SYSTem:COMMunicate:SERial:CONTRol:RTS	RFR
SYSTem:COMMunicate:SERial:PACE	NONE
SYSTem:COMMunicate:SERial:BAUD	9600
SYSTem:COMMunicate:SERial:PARITY	NONE
SYSTem:COMMunicate:SERial:SBITs	1
SYSTem:COMMunicate:SERial:TRANsmit:TERMinator	LF
SYSTem:COMMunicate:SERial:TRANsmit:DELay	0

<b>Dependencies</b>	None
<b>Errors and Events</b>	None
<b>Examples</b>	SYSTEM:COMMUNICATE:SERIAL:PRESET
<b>Related Commands</b>	None

## SYSTEM:COMMUNICATE:SERIAL:CONTROL:DCD

This command sets or queries Data Carrier Detect (DCD) sensitivity on and off.

**Syntax** SYSTEM:COMMUNICATE:SERIAL:CONTROL:DCD <DCD mode>  
SYSTEM:COMMUNICATE:SERIAL:CONTROL:DCD?

Parameters	<DCD mode> (boolean)	Description
	1 or ON	DCD on (default)
	0 or OFF	DCD off

<b>Dependencies</b>	None
<b>Errors and Events</b>	None
<b>Examples</b>	Set: SYSTEM:COMMUNICATE:SERIAL:CONTROL:DCD OFF Query: SYSTEM:COMMUNICATE:SERIAL:CONTROL:DCD? Response: 1
<b>Related Commands</b>	None

## SYSTEM:COMMunicate:SERial:CONTrol:RTS

This command sets or queries the hardware handshaking scheme. When set to ON, handshaking is off (the instrument is not sensitive to the CTS 750). When set to RFR or IBFULL, the normal RTS/CTS hardware handshaking is on (the instrument indicates ready to receive with the RTS line).

**Syntax** SYSTEM:COMMunicate:SERial:CONTrol:RTS <serial RTS>  
 SYSTEM:COMMunicate:SERial:CONTrol:RTS?

Parameters	<serial RTS> (discrete)	Description
	ON	Not sensitive to the CTS 750; RTS line always asserted (handshaking is off)
	RFR	Ready For Receiving (handshaking is on)
	IBFULL	same as RFR

**Dependencies** None

**Errors and Events** None

**Examples**  
 Set: SYSTEM:COMMUNICATE:SERIAL:CONTROL:RTS RFR  
 Query: SYSTEM:COMMUNICATE:SERIAL:CONTROL:RTS?  
 Response: RFR

**Related Commands** None

**SYSTem:COMMunicate:SERial:BAUD**

This command sets or queries the baud rate (both transmit and receive) of the serial port.

**Syntax** SYSTem:COMMunicate:SERial:BAUD <serial baud>  
SYSTem:COMMunicate:SERial:BAUD?

Parameters	<serial baud> (NR1-numeric)	Description
	9600	9600 baud (default)
	1200	1200 baud
	2400	2400 baud
	4800	4800 baud

**Dependencies** None

**Errors and Events** None

**Examples**  
Set: SYSTem:COMM:SER:BAUD 1200  
Query: SYSTem:COMM:SER:BAUD?  
Response: 2400

**Related Commands** None

## SYSTem:COMMunicate:SERial:PARity

This command sets or queries the parity of the serial port.

**Syntax** SYSTem:COMMunicate:SERial:PARity <serial parity>  
 SYSTem:COMMunicate:SERial:PARity?

Parameters	<serial parity> (discrete)	Description
	NONE	No parity is sent or received (default)
	EVEN	Even parity is sent and received
	ODD	Odd parity is sent and received

**Dependencies** None

**Errors and Events** None

**Examples**  
 Set: SYSTem:COMMunicate:SERial:PARITY EVEN  
 Query: SYSTem:COMMunicate:SERial:PARITY?  
 Response: EVEN

**Related Commands** None

## SYSTem:COMMunicate:SERial:SBITs

This command sets or queries the number of stop bit used by the serial port.

**Syntax** SYSTem:COMMunicate:SERial:SBITs <serial sbits>  
 SYSTem:COMMunicate:SERial:SBITs?

Parameters	<serial sbits> (NR1-numeric)	Description
	1 or 2	Number of stop bits used by the serial port

**Dependencies** None

**Errors and Events**    None

**Examples**    Set:        SYSTEM:COMMUNICATE:SERIAL:SBITS 1  
                   Query:       SYSTEM:COMMUNICATE:SERIAL:SBITS?  
                   Response: 2

**Related Commands**    None

## SYSTEM:COMMUNICATE:SERIAL:PACE

This command sets or queries the software pacing scheme.

**Syntax**    SYSTEM:COMMUNICATE:SERIAL:PACE <serial pace>  
                   SYSTEM:COMMUNICATE:SERIAL:PACE?

### Parameters

<serial pace> (discrete)	Description
NONE	Software pacing disabled (default)
XON	Software pacing on using control-S and control-Q

**Dependencies**    None

**Errors and Events**    None

**Examples**    Set:        SYSTEM:COMMUNICATE:SERIAL:PACE NONE  
                   Query:       SYSTEM:COMMUNICATE:SERIAL:PACE?  
                   Response: XON

**Related Commands**    None

## SYSTem:COMMunicate:SERial:TRANsmit:DELay

This command sets or queries the delay, in seconds, that the instrument waits after receiving a query and before issuing a response.

**Syntax** SYSTem:COMMunicate:SERial:TRANsmit:DELay <transmit delay>  
SYSTem:COMMunicate:SERial:TRANsmit:DELay?

Parameters	<transmit delay> (NR1-numeric)	Description
	Any integer in the range 0 to 60	Delay in seconds that instrument waits after receiving a query before issuing a response (default= 0)

**Dependencies** None

**Errors and Events** None

**Examples**  
Set: SYSTem:COMMunicate:SERial:TRANsmit:DELay 5  
Query: SYSTem:COMMunicate:SERial:TRANsmit:DELay?  
Response: 3

**Related Commands** None



## SYSTEM:COMMunicate:SERial:TRANsmit:TERMinator

This command sets or queries the character or characters sent with the response message.

**Syntax** SYSTEM:COMMunicate:SERial:TRANsmit:TERMinator <terminator>  
SYSTEM:COMMunicate:SERial:TRANsmit:TERMinator?

Parameters	<terminator> (discrete)	Description
	LF	Line feed (default)
	CR	Carriage return
	CRLF	CR/LF
	LF CR	LF/CR

**Dependencies** None

**Errors and Events** None

**Examples**  
Set: SYSTEM:COMMUNICATE:SERIAL:TRANSMIT:TERMINATOR CRLF  
Query: SYSTEM:COMMUNICATE:SERIAL:TRANSMIT:TERMINATOR?  
Response: CRLF

**Related Commands** None



# Instrument Control Commands

The Instrument Control commands allow you to access utility functions and settings such as errors, query headers, serial number, system time, date, owner, and operator. This section contains all of the commands and queries for the following SYSTem subsystem.

## SYSTem Subsystem

This section describes each of the commands and queries that allow you to access general utility functions and settings in the instrument. Figure 2-54 shows the hierarchy tree for this subsystem.

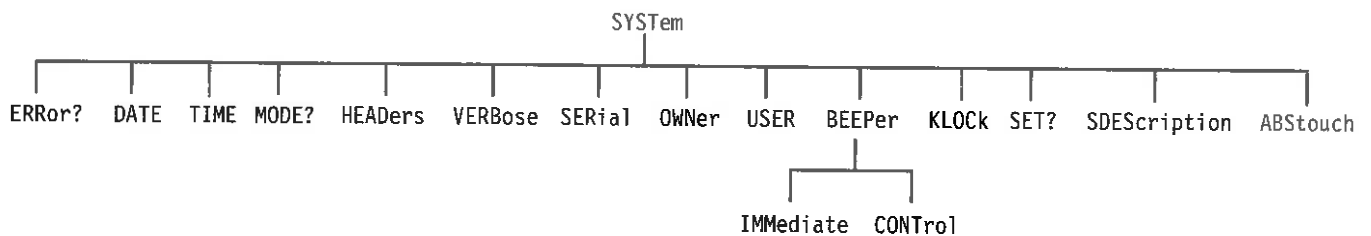

Figure 2-54: SYSTem subsystem

## SYSTem:ERRor?

This query returns the errors and events that have accumulated in the instrument. If no errors are present in the instrument, the response is: 0, "No Error".

**Syntax** SYSTem:ERRor?

**Response**

<b>&lt;error number&gt; (NR1-numeric)</b>	<b>Description</b>
Any integer in the range 0 to 999	This value indicates the error number
<b>&lt;error description&gt; (string)</b>	<b>Description</b>
Primary error message and, optionally, a secondary error message	This string describes the error

- Dependencies**      None
  
- Errors and Events**      See the *Messages* tables in the *Status and Events* section.
  
- Examples**      Query:      SYSTEM:ERROR?  
                   Response: 200, "Execution error; Pointer burst active, request ignored"
  
- Related Commands**      None

## SYSTEM:DATE

This command sets or queries the date for the instrument.

**Syntax**      SYSTEM:DATE <year>,<month>,<day>  
                   SYSTEM:DATE?

**Parameters**

<b>&lt;year&gt; (NR1-numeric)</b>	<b>Description</b>
Any integer in the range 0 to 99	The system year is set to this value
<hr/>	
<b>&lt;month&gt; (NR1-numeric)</b>	<b>Description</b>
Any integer in the range 1 to 12	The system month is set to this value
<hr/>	
<b>&lt;day&gt; (NR1-numeric)</b>	<b>Description</b>
Any integer in the range 1 to 31	The system day is set to this value

- Dependencies**      None
  
- Errors and Events**      None
  
- Examples**      Set:          SYSTEM:DATE 97,5,1  
                   Query:      SYSTEM:DATE?  
                   Response: 97,5,26
  
- Related Commands**      SYSTEM:TIME

## SYSTem:TIME

This command sets or queries the time for the instrument. Time is kept in a 24-hour format.

**Syntax** SYSTem:TIME <hour>,<minute>,<second>  
SYSTem:TIME?

Parameters	<hour> (NR1-numeric)	Description
	Any integer in the range 0 to 23	The system hour is set to this value
	<minute> (NR1-numeric)	Description
	Any integer in the range 0 to 59	The system minute is set to this value
	<second> (NR1-numeric)	Description
	Any integer in the range 0 to 59	The system second is set to this value

**Dependencies** None

**Errors and Events** None

**Examples**  
Set: SYSTem:TIME 13,7,56  
Query: SYSTem:TIME?  
Response: 22,15,00

**Related Commands** SYSTem:DATE

## SYSTem:MODE?

This query returns the mode of the instrument.

**Syntax** SYSTem:MODE?

Response	<system mode> (discrete)	Description
	SDH	Instrument is set to SDH mode

**Dependencies** None

**Errors and Events** None

**Examples**  
 Query: SYSTEM:MODE?  
 Response: SDH

**Related Commands** SYSTem:MODE

## SYSTem:HEADers

This command sets or queries the presence of headers in query responses.

**Syntax** SYSTem:HEADers <system headers>  
 SYSTem:HEADers?

Parameters	<system headers> (boolean)	Description
	0 or OFF	No system headers are returned (default)
	1 or ON	System headers are returned

**Dependencies** None

**Errors and Events** None

**Examples**  
 Set: SYSTEM:HEADERS OFF  
 Query: SYSTEM:HEADERS?  
 Response: 0

**Related Commands** None

## SYSTem:VERBoSe

This command sets or queries the length of headers in query responses. If verbose is ON, the long form of headers is returned. If verbose is OFF, the short form is returned.

**Syntax** SYSTem:VERBoSe <system verbose>  
SYSTem:VERBoSe?

Parameters	<system verbose> (boolean)	Description
	0 or OFF	Short form of headers (default)
	1 or ON	Long form of headers

**Dependencies** SYSTem:HEADers must be set to ON for headers to be returned.

**Errors and Events** None

**Examples**  
Set:       SYSTem:VERBoSe OFF  
Query:     SYSTem:VERBoSe?  
Response:  0

**Related Commands** None

## SYSTem:SERIal

This command sets or queries the instrument serial number. The factory assigns the serial number; however, you may alter the serial number. Only ASCII alphanumeric characters are accepted.

**Syntax** SYSTem:SERIal <serial number>  
SYSTem:SERIal?

Parameters	<serial number> (string)	Description
	Any ASCII string, maximum length of 16	The instrument serial number is set to this value

**Dependencies**    None

**Errors and Events**    None

**Examples**

Set:            SYSTEM:SERIAL "B010100"

Query:        SYSTEM:SERIAL?

Response:    B010345

**Related Commands**    \*IDN?

## SYSTem:OWNer

This command sets or queries the instrument owner. This information is saved in the results buffer and printed in hardcopy reports.

**Syntax**    SYSTem:OWNer <system owner>  
 SYSTem:OWNer?

Parameters	<system owner> (string)	Description
	Any ASCII string, maximum length of 64	The instrument system owner is set to this value

**Dependencies**    None

**Errors and Events**    None

**Examples**

Set:            SYSTEM:OWNER "The ABC TELECOM COMPANY"

Query:        SYSTEM:OWNER?

Response:    "THE XYZ TELECOM COMPANY"

**Related Commands**    None



## SYSTem:USER

This command sets or queries the instrument operator name. This information is saved in the results buffer and printed in hardcopy reports.

**Syntax** SYSTem:USER <operator name>  
SYSTem:USER?

Parameters	<operator name> (string)	Description
	Any ASCII string, maximum length of 64	The instrument operator name is set to this value

**Dependencies** None

**Errors and Events** None

**Examples**  
Set: SYSTem:USER "JOHN DOE"  
Query: SYSTem:USER?  
Response: "JOHN TECHNICIAN"

**Related Commands** SYSTem:OWNer

## SYSTem:BEEPer:IMMediate

This command is used to sound the beeper in the instrument.

**Syntax** SYSTem:BEEPer:IMMediate

**Parameters** None

**Dependencies** None

**Errors and Events**    None

**Examples**            SYSTEM:BEEPER:IMMEDIATE

**Related Commands**    SYSTem:BEEPer:CONTrol

## SYSTem:BEEPer:CONTrol

This command sets or queries the beeper control.

**Syntax**            SYSTem:BEEPer:CONTrol <beeper control>  
 SYSTem:BEEPer:CONTrol?

Parameters	<beeper control> (boolean)	Description
	0 or OFF	Use SYSTem:BEEPer:IMMEDIATE to sound the beeper (default)
	1 or ON	The beeper sounds when any error, alarm, or failure is detected

**Dependencies**        None

**Errors and Events**    None

**Examples**            Set:            SYSTEM:BEEPER:CONTROL ON  
                   Query:         SYSTEM:BEEPER:CONTROL?  
                   Response:    1

**Related Commands**    None

## SYSTem:KLOCK

This command sets or queries the front panel lock setting. (KLOCK stands for keyboard lock.)

**Syntax** SYSTem:KLOCK <front panel control>  
SYSTem:KLOCK?

**Parameters**

<front panel control> (boolean)	Description
0 or OFF	Front panel enabled (default)
1 or ON	Front panel disabled

**Dependencies** None

**Errors and Events** None

**Examples** Set: SYSTem:KLOCK ON  
Query: SYSTem:KLOCK?  
Response: 1

**Related Commands** None

## SYSTem:SET?

This query returns the current instrument state and performs the same function as the \*LRN? query.

**Syntax** SYSTem:SET?

**Response** A list of commands and their parameter values separated by semicolons (;) (see *Appendix C* for a complete list).

**Dependencies** None

**Errors and Events** None

**Examples**    Query:    SYSTEM:SET?

                  Response: :OUTPUT1:TELECOM:RATE STM1;TYPE ELECTRICAL;LEVEL  
XCONNECT;:SOURCE:CLOCK:SOURCE INTERNAL;OFFSET:MODE  
LOFFSET;LVALUE 0;:SOURCE:DATA:TELECOM:SOURCE OUTPUT1;  
\*\*\*

**Related Commands**    \*LRN?

## SYSTEM:SDEscription

This command sets or queries the description for the stored settings in the current buffer.

**Syntax**    SYSTEM:SDEscription <description>  
SYSTEM:SDEscription?

Parameters	<description> (string)	Description
	Any string, maximum length of 24 characters	Description of the stored strings in the current buffer

**Dependencies**    After you set the description with this command, use the \*SAV command to save the description and settings in memory or the MMEMemory:STORe:SETTings command to save the description and settings to disk.

**Errors and Events**    None

**Examples**    Set:            SYSTEM:SDESCRIPTION "PASS/FAIL TEST A001"

                  Query:        SYSTEM:SDESCRIPTION?

                  Response:    "PASS/FAIL TEST T001"

**Related Commands**    \*SAV  
                              \*RCL  
                              MMEMemory:STORe:SETTings

## SYSTem:ABStouch

This command simulates front panel button presses and knob turns.

**Syntax** SYSTem:ABStouch <abstouch>

### Parameters

<abstouch> (discrete)	Description
HB1	Horizontal bezel #1 (left-most button)
HB2	Horizontal bezel #2
HB3	Horizontal bezel #3
HB4	Horizontal bezel #4
HB5	Horizontal bezel #5
HB6	Horizontal bezel #6
HB7	Horizontal bezel #7 (right-most button)
VB1	Vertical bezel #1 (top button)
VB2	Vertical bezel #2
VB3	Vertical bezel #3
VB4	Vertical bezel #4
VB5	Vertical bezel #5 (bottom button)
STESTs	Stored tests menu
TRANsmit	Transmitter setup menu
RECEiver	Receiver setup menu
RESults	Results menu
UTILity	Utility menu
STARTSTOP	Start/Stop button
STOP	Start/Stop button
IERRor	Error insert button
POINter	Pointer Action button
RHIStory	Reset History button
INCKnob	Increment knob
DECKnob	Decrement knob
HELP	Help dialog button
AUTOscan	Autoscan dialog button
PRINT	Print dialog button

<b>Dependencies</b>	None
<b>Errors and Events</b>	None
<b>Examples</b>	SYSTEM:ABSTOUCH VB1
<b>Related Commands</b>	None

# Diagnostic and Calibrate Commands

This section contains all of the commands and queries for the diagnostic and calibrate subsystems.

## DIAGnostic Subsystem

This section describes each of the commands and queries that allow access and control of the diagnostic self tests provided with your instrument. Figure 2-55 shows the hierarchy tree for this subsystem.

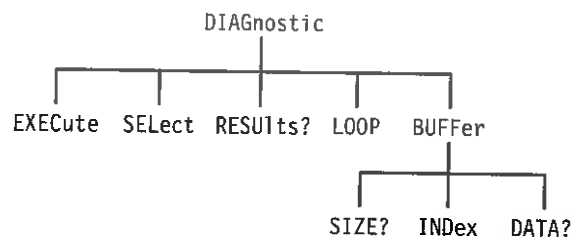

Figure 2-55: DIAGnostic subsystem

## DIAGnostic:EXECute

This command executes the selected diagnostic routines and sets the OPC bit when completed.

**Syntax** DIAGnostic:EXECute

**Parameters** None

**Dependencies** The routines executed are determined by the DIAGnostic:SElect command.

**Errors and Events** 200, "Execution error; Diagnostics invalid while disk or autoscan busy"  
402, "Operation complete; Internal diagnostics completed – passed"  
402, "Operation complete; Internal diagnostics completed – failed"

**Examples** DIAGNOSTIC:EXECUTE

**Related Commands**    DIAGnostic:SElect  
\*TST?

## DIAGnostic:SElect

This command sets or queries the specified diagnostic routine that are run when the DIAGnostic:EXECute command is sent.

**Syntax**    DIAGnostic:SElect <diagnostic group>  
DIAGnostic:SElect?

### Parameters

<diagnostic group> (discrete)	Description
STANdard	Standard self test; same as the *TST? query (default)
PROcEssor	Processor board
PROToCol	Protocol board
CLOCK	Clock generator board
DISK	Disk drive
DISPlay	Display board
TRIButary	Tributary board (Add/Drop Test Option Only)
INTERFACE	Line interface module
FPANel	Front Panel
SYSINTERNAL	Complete system (internal loopback)
SYSEXTERNAL	Complete system (external loopback)
JITier	Jitter module

**Dependencies**    None

**Errors and Events**    None



**Examples** Set: DIAGNOSTIC:SELECT STANDARD  
 Query: DIAGNOSTIC:SELECT?  
 Response: JITTER

**Related Commands** DIAGnostic:EXECute

## DIAGnostic:RESuLts?

This query returns the results from the last diagnostics execution. These diagnostics could have been run at the power-on self test or as a result of sending the DIAGnostic:EXECute command or \*TST? query.

If any SCPI-derived or IEEE 488.2 Common Command is sent while the diagnostics are running, the diagnostics will stop. The DIAGnostic:RESuLts? query can then be used to determine if the selected diagnostic test passed or failed.

**Syntax** DIAGnostic:RESuLts?

Response	<diagnostic results> (discrete)	Description
	PASSED	Test passed
	FAILED	Test failed
	ABORTED	Test aborted

**Dependencies** None

**Errors and Events** None

**Examples** Query: DIAGNOSTIC:RESULTS?  
 Response: PASSED

**Related Commands** DIAGnostic:SElect  
 DIAGnostic:EXECute

**DIAGnostic:LOOP**

This command sets or queries the looping control used for diagnostic routines when the DIAGnostics:EXECute command is given.

**Syntax** DIAGnostic:LOOP <loop control>  
DIAGnostic:LOOP?

Parameters	<loop control> (discrete)	Description
	ONCE	One pass (default)
	TEN	Loop ten times
	THOUSAND	Loop one thousand times
	ERRor	Loop until error detected
	FOREVER	Loop until any command is sent

**Dependencies** None

**Errors and Events** None

**Examples**  
Set:       DIAGNOSTIC:LOOP TEN  
Query:     DIAGNOSTIC:LOOP?  
Response:  ONCE

**Related Commands** DIAGnostic:EXECute

This query returns the current setting of the looping control used for diagnostic routines when the DIAGnostics:EXECute command is given.

## DIAGnostic:BUFFER:SIZE?

This query returns the number of entries in the diagnostics results buffer. The <buffer size> is the maximum value you can use in the DIAGnostic:BUFFER:INDEX command.

**Syntax** DIAGnostic:BUFFER:SIZE?

Response	<buffer size> (NR1-numeric)	Description
	Any integer	The number of entries in the results buffer (0 indicates that no errors were found in the diagnostics)

**Dependencies** None

**Errors and Events** None

**Examples** Query: DIAGNOSTIC:BUFFER:SIZE?  
Response: 5

**Related Commands** DIAGnostic:BUFFER:INDEX

## DIAGnostic:BUFFer:INDEX

This command sets or queries the buffer that is used by the DIAGnostic:BUFFer:DATA? query. The <buffer number> must be less than or equal to the <buffer size> value returned from the DIAGnostic:BUFFer:SIZE? query. When the DIAGnostic:EXECute command is given, the <buffer number> is reset to 1.

**Syntax**     DIAGnostic:BUFFer:INDEX <buffer number>

Parameters	<buffer number> (NR1-numeric)	Description
	Any integer; must be less than or equal to the integer returned from the DIAGnostic:BUFFer:SIZE? query	Buffer used by the DIAGnostic:BUFFer:DATA? query (default = 1)

**Dependencies**     None

**Errors and Events**     None

**Examples**

Set:             DIAGNOSTIC:BUFFER:INDEX 1

Query:          DIAGNOSTIC:BUFFER:INDEX?

Response:     12

**Related Commands**

DIAGnostic:BUFFer:SIZE?  
 DIAGnostic:BUFFer:DATA?  
 DIAGnostic:BUFFer:EXECute

## DIAGnostic:BUFFer:DATA?

This query returns detailed description of the diagnostic results. Use the DIAGnostic:BUFFer:INDEX command to select the buffer to view.

**Syntax**     DIAGnostic:BUFFer:DATA?

Response	<diagnostic description> (string)	Description
	An ASCII string, maximum length 160	A detailed description of the diagnostic results

**Dependencies**     None

**Errors and Events**     None

**Examples**     Query:     DIAGNOSTIC:BUFFER:DATA?  
 Response: "MEMORY TEST FAILED - WROTE AA READ 55"

**Related Commands**     DIAGnostic:BUFFer:INDEX  
 DIAGnostic:SElect  
 DIAGnostic:EXECute

## CALibrate Subsystem

This section describes the calibrate commands and queries. Figure 2–20 shows the hierarchy tree for this subsystem.

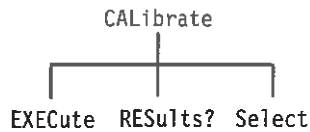

**Figure 2–56: CALibrate subsystem**

### Calibrate:EXECute

SDH/PDH Jitter/Wander Test Option Only

This command runs a selected calibration routine.

**Syntax** CALibrate:EXECute

**Dependencies** Requires installation of Option 14 jitter module.  
 CALibrate:SElect sets which calibration routines to run.

This command sets the Operation Complete bit in the Standard Event Status Register (SESR).

**Errors and Events** None

**Examples** CALIBRATE:EXECUTE

**Related Commands** CALibrate:SElect, \*CAL?

**CALibrate:RESults?**

SDH/PDH Jitter/Wander Test Option Only

This query returns the results from CALibrate:EXECute or power-up self-test calibration routines.

**Syntax** CALibrate:RESults?

**Response**

<cal results> (discrete)	Description
PASSED	Selected or self-test calibration tests passed
FAILED	Selected or self-test calibration tests failed
ABORTED	Selected or self-test calibration tests stopped before completed
RUNNING	Calibration is running

**Dependencies** None

**Errors and Events** None

**Examples** Query: CALIBRATE:RESULTS?

Response: PASSED

**Related Commands** CALibrate:EXECute, CALibrate:SElect

## Calibrate:SElect

SDH/PDH Jitter/Wander Test Option Only

This command sets or queries the calibration routine to run when executing CALibrate:EXECute.

**Syntax** CALibrate:SElect <cal select>  
CALibrate:SElect?

Parameters	<cal select> (discrete)	Description
	JGEN	Run all jitter generation system calibration routines
	JMEAS	Run all jitter measurement system calibration routines (default)

**Dependencies** Requires installation of Option 14 jitter module.  
\*RST sets to JMEAS (default).

**Errors and Events** None

**Examples**  
Set: CALIBRATE:SELECT JGEN  
Query: CALIBRATE:SELECT?  
Response: JGEN

**Related Commands** CALibrate:EXECute



# Common Commands

This section describes each of the IEEE 488.2 Common Commands in detail. See page 2–10 for information on reading the <decimal value> tables contained in this section.

## \*CLS

This command clears all status registers and error queues.

<b>Syntax</b>	*CLS
<b>Parameters</b>	None
<b>Dependencies</b>	None
<b>Errors and Events</b>	None
<b>Examples</b>	*CLS
<b>Related Commands</b>	None

**\*ESE**

This command sets the contents of the Event Status Enable Register. This register controls the reporting of specific errors through the status register and the interrupt mechanism.

**Syntax** \*ESE <decimal value>

**Parameters**

<decimal value> (NR1-numeric)	Bit	Description
1	0	Operation complete
2	1	Not used
4	2	Query error
8	3	Device dependent error
16	4	Execution error
32	5	Command error
64	6	Not used
128	7	Power on

**Dependencies** None

**Errors and Events** None

**Examples** \*ESE 16

**Related Commands** \*ESE?

**\*ESE?**

This query returns the contents of the Event Status Enable Register.

**Syntax** \*ESE?

**Response**

<decimal value> (NR1-numeric)	Bit	Description
1	0	Operation complete
2	1	Not used
4	2	Query error
8	3	Device dependent error
16	4	Execution error
32	5	Command error
64	6	Not used
128	7	Power on

**Dependencies** None

**Errors and Events** None

**Examples** Query: \*ESE?  
Response: 64

**Related Commands** \*ESE

**\*ESR?**

This query returns the contents of the Standard Event Status Register. This register shows the status of general instrument-related events as bits encoded into a number.

**Syntax** \*ESR?

**Response**

<decimal value> (NR1-numeric)	Bit	Description
1	0	Operation complete
2	1	Not used
4	2	Query error
8	3	Device dependent error
16	4	Execution error
32	5	Command error
64	6	Not used
128	7	Power on

**Dependencies** None

**Errors and Events** None

**Examples** Query: \*ESR?

Response: 64

**Related Commands** \*ESE

**\*IDN?**

This query returns the identity of the instrument.

<b>Syntax</b>	*IDN?
<b>Response</b>	<manufacturer>,<model>,<serial number>,<firmware version>
<b>Dependencies</b>	None
<b>Errors and Events</b>	None
<b>Examples</b>	Query:     *IDN? Response: "TEKTRONIX,CTS750,000000000,CF:91.1C FV1.20"
<b>Related Commands</b>	None

**\*LRN?**

This query returns an ASCII representation of the current instrument setup.

<b>Syntax</b>	*LRN?
<b>Response</b>	A list of commands and their parameter values separated by semicolons (;) (see <i>Appendix C</i> for a complete list).
<b>Dependencies</b>	None
<b>Errors and Events</b>	None
<b>Examples</b>	Query:     *LRN? Response: ":OUTPUT1:TELECOM:RATE STM1;TYPE ELECTRICAL;LEVEL XCONNECT;:SOURCE:CLOCK:SOURCE INTERNAL;OFFSET:MODE LOFFSET;LVALUE 0;:SOURCE:DATA:TELECOM:SOURCE OUTPUT1; ...."
<b>Related Commands</b>	None

## \*RST

This command resets the instrument and puts it into a default state, which is independent of past historical setups. *Appendix D* summarizes the effect of \*RST on the instrument. This command sets the Operation Complete bit in the Standard Event Status Register.

<b>Syntax</b>	*RST
<b>Parameters</b>	None
<b>Dependencies</b>	None
<b>Errors and Events</b>	402, "Operation complete; Instrument factory reset complete"
<b>Examples</b>	*RST
<b>Related Commands</b>	None

**\*SRE**

This command sets the contents of the Service Request Enable Register. This register controls the reporting of specific errors through the status register and the interrupt mechanism.

**Syntax** \*SRE <decimal value>

**Parameters**

<decimal value> (NR1-numeric)	Bit	Description
1	0	Not used
2	1	Not used
4	2	Not used
8	3	Not used
16	4	Message available
32	5	Event status summary
64	6	Not used
128	7	Not used

**Dependencies** None

**Errors and Events** None

**Examples** \*SRE 64

**Related Commands** \*SRE?

## \*SRE?

This query returns the contents of the Service Request Enable Register.

**Syntax** \*SRE?

**Response**

<decimal value> (NR1-numeric)	Bit	Description
1	0	Not used
2	1	Not used
4	2	Not used
8	3	Not used
16	4	Message available
32	5	Event status summary
64	6	Not used
128	7	Not used

**Dependencies** None

**Errors and Events** None

**Examples** Query: \*SRE?  
Response: 64

**Related Commands** \*SRE



**\*STB?**

This query returns the contents of the Status Byte Register.

**Syntax** \*STB?

**Response**

<decimal value> (NR1-numeric)	Bit	Description
1	0	Not used
2	1	Not used
4	2	Error/event queue not empty
8	3	Not used
16	4	Message available
32	5	Event status summary
64	6	Request service/Master status summary
128	7	Not used

**Dependencies** None

**Errors and Events** None

**Examples** Query: \*STB?

Response: 64

**Related Commands** \*SRE  
\*SRE?

## \*OPC

This command causes the instrument to generate the Operation Complete message in the Standard Event Status Register when all pending instrument operations have been finished.

<b>Syntax</b>	*OPC
<b>Parameters</b>	None
<b>Dependencies</b>	None
<b>Errors and Events</b>	None
<b>Examples</b>	*OPC
<b>Related Commands</b>	*OPC?

## \*OPC?

This query returns a 1 when all pending device operations have finished.

<b>Syntax</b>	*OPC?
<b>Response</b>	1
<b>Dependencies</b>	None
<b>Errors and Events</b>	None
<b>Examples</b>	Query: *OPC? Response: 1
<b>Related Commands</b>	None

**\*OPT?**

This query returns the installed hardware options and the instrument and option configuration information. <option name> is repeated for each option; <instrument configuration> and <option configuration> are listed only once.

**Syntax** \*OPT?

**Response** <option name>,<instrument configuration>,<option configuration>

**Dependencies** None

**Errors and Events** None

**Examples** Query: \*OPT?

Response: "OPT/ELEC 1310nm: 55/155/622,2/34/140: ADD/DROP/TEST,  
[C18:PO:HO:K0:D0:F8:X2.93],[I1:T3:TX0.318:J-]"

**Related Commands** None

**\*RCL**

This command recalls the instrument state from an internal storage buffer. Five buffers are available for use. This command sets the Operation Complete bit in the Standard Event Status Register.

**Syntax** \*RCL <buffer number>

Parameters	<buffer number> (NR1-numeric)	description
	1 to 5	Storage buffers 1 to 5

**Dependencies** None

**Errors and Events** 230, "Data corrupt or stale; Recall buffer is empty"  
 221, "Settings conflict; Internal buffer is empty"

**Examples** \*RCL 1

**Related Commands** \*SAV

## \*SAV

This command saves the instrument state into an internal storage buffer. Five buffers are available for use. This command sets the Operation Complete bit in the Standard Event Status Register.

**Syntax** \*SAV <buffer number>

Parameters	<buffer number> (NR1-numeric)	description
	1 to 5	Storage buffers 1 to 5

**Dependencies** None

**Errors and Events** None

**Examples** \*SAV 1

**Related Commands** \*RCL

**\*TST?**

This query invokes the instrument self-test routines and returns the result when they complete. The OPC bit in the Standard Event Status Register is set when the self-test routines are complete.

**Syntax** \*TST?

**Response**

<test results> (NR1-numeric)	description
0	Test complete and successful
1	Test complete and failed

**Dependencies** None

**Errors and Events** 402, "Operation complete; Internal diagnostics completed – passed"  
402, "Operation complete; Internal diagnostics completed – failed"

**Examples** Query: \*TST?

Response: 0

**Related Commands** DIAGnostics:RESults?  
DIAGnostics:EXECute

## **\*WAI**

This command prevents any commands or queries from executing until the command that is currently executing sets the OPC bit.

<b>Syntax</b>	*WAI
<b>Parameters</b>	None
<b>Dependencies</b>	None
<b>Errors and Events</b>	None
<b>Examples</b>	*WAI
<b>Related Commands</b>	None

# Status and Events

The Status and Event Reporting System reports asynchronous events and errors that occur in the CTS 750 SDH Test Set. This system consists of four 8-bit registers and two queues that you access through the command language. You can use these registers and queues to query the instrument status and control the interrupts that report events.

In general, after an interrupt occurs, first conduct a serial poll, query the registers to see why the interrupt occurred, and then send the `SYSTEM:ERROR?` query to see a descriptive error message.

This section describes the four registers and two queues of the Status and Event Reporting System. For each register, you are given a description, a table describing all of the bits, and an example of how to use the register. Also described in this section is the Status and Event Reporting process, synchronizing programming commands, and the system messages.

## Status and Event Reporting System

The Status and Event Reporting System monitors and reports such events as an error occurring or the availability of a response to a query. This system includes descriptions of the following registers and queues:

- Status Byte Register
- Service Request Enable Register
- Standard Event Status Register
- Event Status Enable Register
- Output Queue
- System Error and Event Queue

### Status Byte Register

The Status Byte Register, shown in Table 3-1, summarizes information from other registers. Use a serial poll or a `*STB?` query to read the contents of the Status Byte Register. The response is the sum of the decimal values for all bits set. When you use a serial poll, bit 6 shows Request Service information. When you use the `*STB?` query, bit 6, the Master Status Summary bit, indicates that bits 4 or 5 may be set. Using the `*STB?` query clears all bits in the Status Byte Register.

**Table 3-1: The Status Byte Register**

Bit	Decimal Value	Function
0-1	–	Not used
2	4	<b>Error/Event Queue not empty</b> indicates that information is contained in the error/event queue and is waiting to be read.
3	–	Not used
4	16	<b>Message Available</b> shows that output is available in the Output Queue.
5	32	<b>Event Status Bit</b> indicates that one or more events have occurred and the corresponding bits in the Standard Event Status Register have been set.
6	64	<b>Request Service</b> (obtained from a serial poll) shows that the CTS 750 has requested service from the GPIB controller.  <b>Master Status Summary</b> (obtained from *STB? query) summarizes the event status bit and message available bits in the Status Byte Register.
7	–	Not used

A common example of using the Status Byte Register is to enable only the Event Status and Request Service bits. Enable bits 5 and 6 using the Service Request Enable Register (see the next section for information about this register). If the \*STB? query returns a value of 96, bit 5 (decimal value of 32) and bit 6 (decimal value of 64) have been set (giving a decimal value sum of 96). Bit 5 indicates that information is available in the Standard Event Status Register, and bit 6 indicates that bits 4 or 5 are set in the Status Byte Register.

**Service Request Enable Register**

The Service Request Enable Register, shown in Table 3-2, controls which bits in the Status Byte Register will generate a service request. Use the \*SRE command to set bits in the Service Request Enable Register. Use the \*SRE? query to see which bits in this register are enabled. The response from this query is the sum of the decimal values for all bits set.

**Table 3-2: The Service Request Enable Register**

Bit	Decimal Value	Function
0-3	–	Not used
4	16	<b>Message Available</b> indicates that a message available will generate a service request.



Table 3-2: The Service Request Enable Register (Cont.)

Bit	Decimal Value	Function
5	32	<b>Event Status Bit</b> indicates that events summarized in bit 5 of the Status Byte Register will generate a service request.
6-7	–	Not used

If, for example, the \*SRE? query returns a value of 48, bits 4 and 5 are set in the Service Request Enable Register. Any event that causes the Message Available bit (bit 4) or Event Status bit (bit 5) to be set in the Status Byte Register now generates an interrupt. If you want an interrupt to be generated only when the Event Status bit (bit 5) is set, use the \*SRE 32 command.

### Standard Event Status Register

The Standard Event Status Register, shown in Table 3-3, records many types of events that can occur in the CTS 750. Use the \*ESR? query to read the contents of this register. The response is the sum of the decimal values for all bits set. Reading this register clears all bits so the register can accumulate information about new events.

Table 3-3: The Standard Event Status Register

Bit	Decimal Value	Function
0	1	<b>Operation Complete</b> shows that the operation is complete. This bit is set when all pending operations complete following a *OPC command. Table B-1 in the Appendix lists the commands and queries that set the OPC bit upon completion of execution.
1	–	Not used
2	4	<b>Query Error</b> shows that the CTS 750 attempted to read the Output Queue when no data was present or pending, or that data in the Output Queue was lost.
3	8	<b>Device Dependent Error</b> shows that a device error occurred. Table 3-7 on page 3-10 lists the device error messages.
4	16	<b>Execution Error</b> shows that an error occurred while the CTS 750 was executing a command or query. Table 3-6 on page 3-9 lists the execution error messages.
5	32	<b>Command Error</b> shows that an error occurred while the CTS 750 was parsing a command or query. Table 3-5 on page 3-8 lists the command error messages.

**Table 3–3: The Standard Event Status Register (Cont.)**

Bit	Decimal Value	Function
6	–	Not used
7	128	<b>Power On</b> shows that the CTS 750 was powered on. The completion of the diagnostic tests also sets this bit.

The following example assumes that all bits have been enabled using the Event Status Enable Register (see the next section for information about this register). If a \*ESR? query returns a value of 128, bit 7 (decimal value of 128) is set indicating that the instrument is in the initial power-on state.

Table B–1 in the Appendix lists the commands and queries that set the OPC bit (bit 0 of the Standard Event Status Register) upon completion of execution. Some of these commands and queries may require more than 200 ms to complete execution.

**Event Status Enable Register**

The Event Status Enable Register, shown in Table 3–4, controls which events are summarized in the event status bit (bit 5) of the Status Byte Register. Note that the Event Status Enable Register has the same content as the Standard Event Status Register. Use the \*ESE command to set bits in the Event Status Enable Register. Use the \*ESE? query to see what bits in the Event Status Enable Register are set. The response from this query is the sum of the decimal values for all bits summarized in the event status bit of the Status Byte Register.

**Table 3–4: The Event Status Enable Register**

Bit	Decimal Value	Function
0	1	<b>Operation Complete</b> shows that the operation is complete. This bit is set when all pending operations complete following a *OPC command. Table B–1 in the Appendix lists the commands and queries that set the OPC bit upon completion of execution.
1	–	Not used
2	4	<b>Query Error</b> shows that the CTS 750 attempted to read the Output Queue when no data was present or pending, or that data in the Output Queue was lost.
3	8	<b>Device Dependent Error</b> shows that a device error occurred. Table 3–7 on page 3–10 lists the device error messages.
4	16	<b>Execution Error</b> shows that an error occurred while the CTS 750 was executing a command or query. Table 3–6 on page 3–9 lists the execution error messages.

Table 3-4: The Event Status Enable Register (Cont.)

Bit	Decimal Value	Function
5	32	<b>Command Error</b> shows that an error occurred while the CTS 750 was parsing a command or query. Table 3-5 on page 3-8 lists the command error messages.
6	–	Not used
7	128	<b>Power On</b> shows that the CTS 750 was powered on. The completion of the diagnostic tests also sets this bit.

If, for example, the \*ESE? query returns a value of 255, all bits are set indicating that all events will set the event status bit (bit 5) of the Status Byte Register.

### The Output Queue

The CTS 750 stores query responses in the Output Queue. It empties this queue each time it receives a new command or query message after an End Of Message (EOM). The controller must read a query response before it sends the next command (or query) or it loses responses to earlier queries.

**NOTE.** When a controller sends a query, an EOM, and a second query, the CTS 750 normally clears the first response and outputs the second while reporting a Query Error (bit 2 in the Standard Event Status Register) to indicate the lost response.

### The System Error and Event Queue

The CTS 750 error and event messages are stored in the System Error and Event Queue. Use the SYSTem:ERRor? query to get the event number and a text description of the event. Reading an event removes it from the queue. The Event Queue stores detailed information for up to 20 events; the events are stored in first-in first-out order.

Before reading an event from the Event Queue, use the \*ESR? query to read the summary of the event from the Standard Event Status Register. The events summarized by the \*ESR? query are made available to the SYSTem:ERRor? query, and the Standard Event Status Register is emptied.

Reading the Standard Event Status Register erases any events that were summarized by previous \*ESR? queries but not read from the Event Queue. Events that follow an \*ESR? query are put in the Event Queue but are not available until \*ESR? is given again.

## Status and Event Reporting Process

Figure 3-1 shows how to use the Status and Event Reporting system. In the explanation that follows, numbers in parentheses refer to the circled numbers in Figure 3-1.

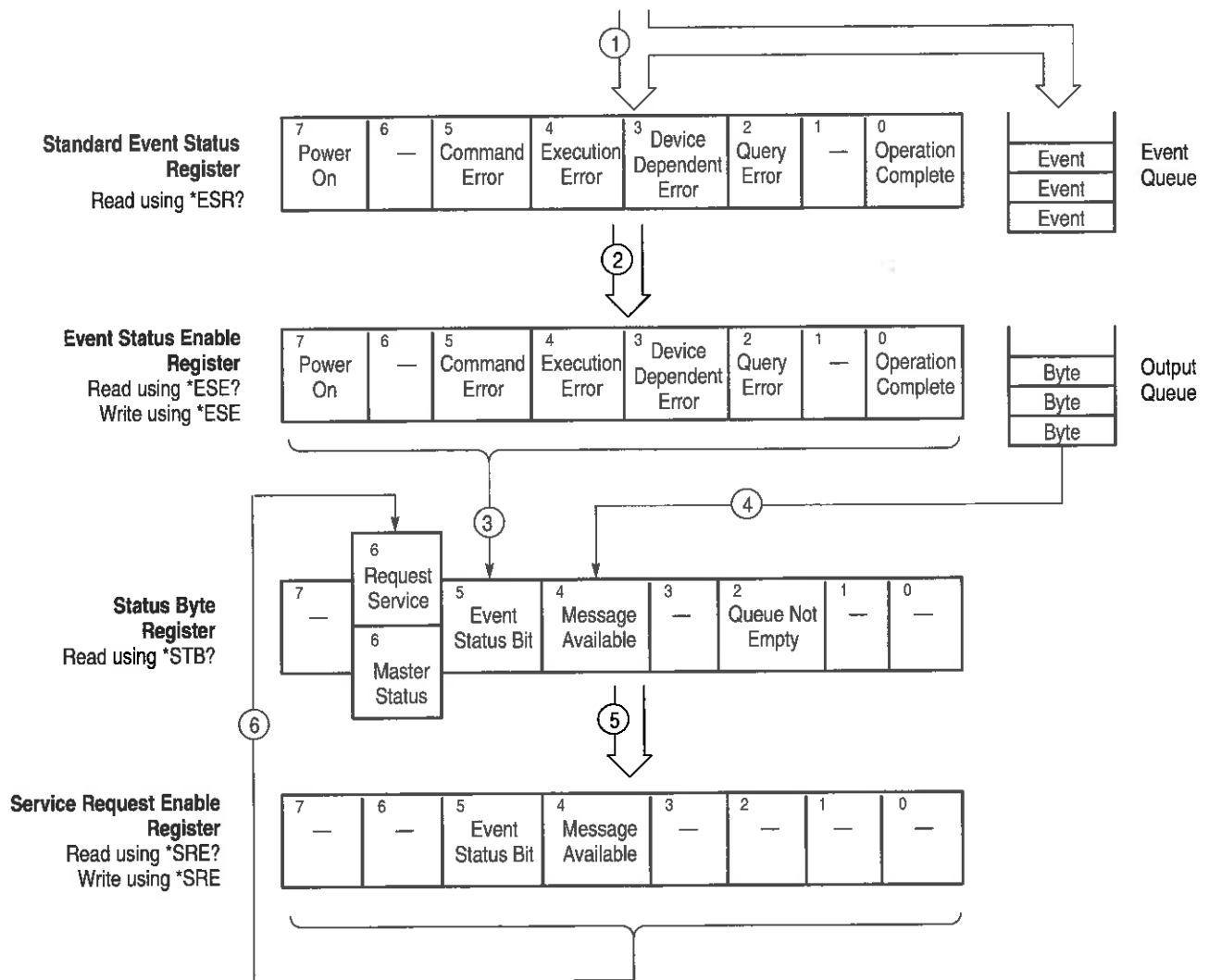

Figure 3-1: Status and Event Reporting Process

When an event occurs the appropriate bit in the Standard Event Status Register is set to one and the event is recorded in the Event Queue (1). If the corresponding bit in the Event Status Enable Register is also enabled (2), then the event status bit in the Status Byte Register is set to one (3).

When output is sent to the Output Queue (for example, a response to a query), the message available bit in the Status Byte Register is set to one (4).

When a bit in the Status Byte Register is set to one and the corresponding bit in the Service Request Enable Register is enabled (5), the master status summary bit in the Status Byte Register is set to one and a service request is generated (6).

## Synchronization Methods

Although most GPIB commands are completed almost immediately after being received by the CTS 750, some commands initiate processes requiring additional time. For example, after you send a `SENSe:DATA:TELEcom:AUTOscan` command, you must wait until it has completed execution before you give another command or query.

Sometimes the result of an operation depends on the result of an earlier operation (the first operation must be completed before the next one is initiated). The status and event reporting system of the CTS 750 provides this capability.

## Using the \*OPC Query

Use the `*OPC?` query to synchronize commands. The `*OPC?` query places a 1 in the Output Queue once an operation is complete. A timeout could occur if you try to read the output queue before there is any data in it.

The same command sequence using the `*OPC?` query for synchronization looks like this:

```
/* Set up a chained message */  
SENSe:DATA:TELECOM:AUTOSCAN;*OPC?
```

## Messages

The CTS 750 generates error messages in response to events caused by commands or queries. Each type of event sets a specific bit in the Standard Event Status Register. Thus, each message is associated with a specific Standard Event Status Register bit. In the message tables that follow, the associated Standard Event Status Register bit is specified in the table title. Not shown in the tables are secondary messages giving more detail about the cause of the error or the meaning of the message. These secondary messages are shown for each command and query in *Syntax and Commands*.

Table 3-5 shows the error messages generated by improper command syntax. Check to see that the command is properly formatted and that it follows the rules in *Syntax and Commands*.

**Table 3-5: Command Error Messages (Bit 5 in Standard Event Status Register)**

Code	Message
100	Command error
101	Invalid character
102	Syntax error
103	Invalid separator
104	Data type error
105	Get not allowed
106	Invalid program data separator
108	Parameter not allowed
109	Missing parameter
110	Command header error
111	Header separator error
112	Mnemonic too long
113	Undefined header
118	Query not allowed
120	Numeric data error
121	Invalid character in number
123	Exponent too large
124	Too many digits
128	Numeric data not allowed
130	Suffix error
131	Invalid suffix
134	Suffix too long

**Table 3-5: Command Error Messages (Bit 5 in Standard Event Status Register) (Cont.)**

Code	Message
138	Suffix not allowed
140	Character data error
141	Invalid character data
144	Character data too long
148	Character data not allowed
150	String data error
151	Invalid string data
158	String data not allowed
160	Block data error
161	Invalid block data
168	Block data not allowed

Table 3-6 lists the execution error messages that can occur during execution of a command.

**Table 3-6: Execution Error Messages (Bit 4 in Standard Event Status Register)**

Code	Message
200	Execution error
220	Parameter error
221	Settings conflict
222	Data out of range
223	Too much data
224	Illegal parameter value
230	Data corrupt or stale
240	Hardware error
241	Hardware missing
250	Mass storage error
252	Missing mass storage
252	Missing media
253	Corrupt media
254	Media full
255	Directory full

**Table 3-6: Execution Error Messages (Bit 4 in Standard Event Status Register) (Cont.)**

Code	Message
256	File name not found
257	File name error
258	Media protected

Table 3-7 lists the device dependent error messages that can occur during CTS 750 operation.

**Table 3-7: Device Dependent Error Messages (Bit 3 in Standard Event Status Register)**

Code	Message
300	Device specific error
310	System error
361	Autoscan failed

Table 3-8 lists the system events.

**Table 3-8: System Events**

Code	Message
401	Power on <sup>1</sup>
402	Operation complete <sup>2</sup>

<sup>1</sup> Sets bit 7 in the Standard Event Status Register.

<sup>2</sup> Sets bit 0 in the Standard Event Status Register.

Table 3-9 lists the execution warnings that can occur during execution of a command.

**Table 3-9: Execution Warning Messages (Bit 3 in Standard Event Status Register)**

Code	Message
500	Execution warnings



## Examples

The following sample program sets up the CTS 750 to perform a one minute bit error rate test. The program is written in Microsoft C and uses a National Instruments GPIB driver. Note that the program verifies communication with the instrument, inserts section code violation errors at a rate of  $10^{-5}$ , loops until the test completes, and prints the BER for the section code violations. Use this program as a basis for programs that perform more advanced tasks. This example program assumes that the instrument is configured to device 4.

```
/*-----  
* Program: BER.C  
* Description: This program will set up the instrument to perform  
*              a 1 minute BER test. The generator may be looped  
*              back to the receiver. Errors will be inserted  
*              during the test. The results will be printed at  
*              the completion of the test.  
* Prerequisites:  
*              The instrument must be configured at device 4 in  
*              IBCONF.  
*              The language is Microsoft C using National  
*              Instruments GPIB drivers.  
*-----  
*/  
  
#include "stdio.h"  
#include "string.h"  
#include "decl.h"  
  
main()  
{  
  
    char buffer[255];  
    int count = 0;
```

```
int status = 0;
int device;
/* announce start of program */
printf("CTS 750 BER Program Starting\n");
/* verify instrument is connected */
device = ibfind ("DEV4");
ibclr( device);
buffer[0] = 0;          /* initialize the string */
ibwrt(device,"*IDN?",5); /* send query to instrument */
ibrd(device, buffer, 255); /* get response from instrument */
buffer[ibcnt-1] = 0;    /* add null to terminate string */
if( ibcnt > 1 )
{
    printf("Instrument at Address 4\n %s\n ", buffer);
}
else
{
    printf("Instrument at Address 4 did not respond");
    return( 1 ); /* error and exit */
}
/* initialize instrument */
ibwrt( device,"SYSTEM:MODE SDH",17);
ibwrt( device "*RST",4);
ibwrt( device "*OPC?",5);
ibrd(device,buffer,255);
/* setup transmitter - B1 errors at 1e-5 rate */
ibwrt( device,"SYSTEM:HEADER 0", 15);
ibwrt( device,"INPUT1:TEL:RATE STM1", 20);
```

```
    ibwrt( device,"OUTPUT1:TEL:RATE STM1", 21);
    ibwrt( device, "SOURCE:DATA:TEL:ERROR:ENABLE ON", 31);
    ibwrt( device, "SOURCE:DATA:TEL:ERROR:TYPE SCV", 30);
    ibwrt( device, "SOURCE:DATA:TEL:ERROR:RATE 1E-5", 31);
    /* setup receiver - test duration of 1 minute */
    ibwrt( device, "SENSE:DATA:TEL:TEST:DURATION 0,0,1,0", 36);
    /* start test */
    ibwrt( device, "SENSE:DATA:TEL:TEST:START", 25);
    /* wait until test is complete */
do
{
    ibwrt( device, "SENSE:DATA:TEL:TEST:STATUS?", 27 );
    ibrd( device, buffer, 255 );
    buffer[ibcnt-1] = 0;    /* add null to terminate string */
    printf(">> Elapsed Time = %s      \r", buffer );
    sscanf( buffer, "%d", &status );
}while( status == 1 );
/* query and print results */
ibwrt( device, "SENSE:DATA:TEL:MEAS:ERROR:ERATIO:SCV?", 37 );
ibrd( device, buffer, 255 );
buffer[ibcnt+1] = 0;      /* add null to terminate string */
printf( "\n>> BER = %s\n", buffer );
/* announce end of program */
printf("End of Test\n");
/* exit */
return(0);
}
```



# Appendix A: ASCII & GPIB Code Chart

B7 B6 BITS B5 B4 B3 B2 B1	0 0 0		0 0 1		0 1 0		0 1 1		1 0 0		1 0 1		1 1 0		1 1 1	
	CONTROL				NUMBERS SYMBOLS				UPPER CASE				LOWER CASE			
0 0 0 0	0 0	NUL	20 10	DLE	40 20	SP	60 30	LA16	100 40	TA0	120 50	TA16	140 60	SA0	160 70	SA16
0 0 0 1	1 1	SOH GTL	21 11	DC1 LL0	41 21	!	61 31	LA17	101 41	TA1	121 51	TA17	141 61	SA1	161 71	SA17
0 0 1 0	2 2	STX	22 12	DC2	42 22	"	62 32	LA18	102 42	TA2	122 52	TA18	142 62	SA2	162 72	SA18
0 0 1 1	3 3	ETX	23 13	DC3	43 23	#	63 33	LA19	103 43	TA3	123 53	TA19	143 63	SA3	163 73	SA19
0 1 0 0	4 4	EOT SDC	24 14	DC4 DCL	44 24	\$	64 34	LA20	104 44	TA4	124 54	TA20	144 64	SA4	164 74	SA20
0 1 0 1	5 5	ENQ PPC	25 15	NAK PPU	45 25	%	65 35	LA21	105 45	TA5	125 55	TA21	145 65	SA5	165 75	SA21
0 1 1 0	6 6	ACK	26 16	SYN	46 26	&	66 36	LA22	106 46	TA6	126 56	TA22	146 66	SA6	166 76	SA22
0 1 1 1	7 7	BEL	27 17	ETB	47 27	'	67 37	LA23	107 47	TA7	127 57	TA23	147 67	SA7	167 77	SA23
1 0 0 0	8 8	BS GET	30 18	CAN SPE	50 28	(	70 38	LA24	110 48	TA8	130 58	TA24	150 68	SA8	170 78	SA24
1 0 0 1	9 9	HT TCT	31 19	EM SPD	51 29	)	71 39	LA25	111 49	TA9	131 59	TA25	151 69	SA9	171 79	SA25
1 0 1 0	10 A	LF	32 1A	SUB	52 2A	*	72 3A	LA26	112 4A	TA10	132 5A	TA26	152 6A	SA10	172 7A	SA26
1 0 1 1	11 B	VT	33 1B	ESC	53 2B	+	73 3B	LA27	113 4B	TA11	133 5B	TA27	153 6B	SA11	173 7B	SA27
1 1 0 0	12 C	FF	34 1C	FS	54 2C	,	74 3C	LA28	114 4C	TA12	134 5C	TA28	154 6C	SA12	174 7C	SA28
1 1 0 1	13 D	CR	35 1D	GS	55 2D	-	75 3D	LA29	115 4D	TA13	135 5D	TA29	155 6D	SA13	175 7D	SA29
1 1 1 0	14 E	SO	36 1E	RS	56 2E	.	76 3E	LA30	116 4E	TA14	136 5E	TA30	156 6E	SA14	176 7E	SA30
1 1 1 1	15 F	SI	37 1F	US	57 2F	/	77 3F	UNL	117 4F	TA15	137 5F	UNT	157 6F	SA15	177 7F	RUBOUT (DEL)
		ADDRESSED COMMANDS		UNIVERSAL COMMANDS		LISTEN ADDRESSES		TALK ADDRESSES		SECONDARY ADDRESSES OR COMMANDS						

## KEY

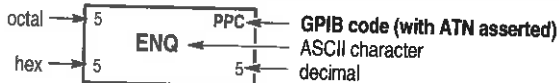

**Tektronix**  
 REF: ANSI STD X3.4-1977  
 IEEE STD 488.1-1987  
 ISO STD 646-2973



## Appendix B: Commands and Queries that set OPC Bit

The commands and queries listed in Table B-1 set the OPC bit after execution. Some of these commands and queries may require more than 200 ms to complete execution.

**Table B-1: Commands and Queries that set OPC bit**

Command or Query
*RST
*RCL
*SAV
*TST?
HCOPY:IMMediate
DIAGnostic:EXECute
all MMEMory: commands
INPUT1:TELEcom:TYPE
SOURce:CLOCK:SOURce
SENSe:DATA:TELEcom:AUTOscan





## Appendix C: Commands Returned by \*LRN?

Table C-1 lists the commands that are returned by the \*LRN? and SYSTem:SET? queries. The response consists of these commands and their parameter values separated by semicolons (;).

**Table C-1: Commands returned by \*LRN?**

Command
SYSTem:MODE
SYSTem:SDEscription
SYSTem:BEEPer:CONTRol
SYSTem:HEADers
SYSTem:VERBose
OUTPUT1:TELEcom:RATE
OUTPUT1:TELEcom:TYPE
OUTPUT1:TELEcom:LEVel
OUTPUT2:TELEcom:TERMinator (Add/Drop Test Option Only)
OUTPUT2:TELEcom:CODE (Add/Drop Test Option Only)
OUTPUT3:TELEcom:RATE (Add/Drop Test Option Only)
SOURce:CLOCK:SOURce
SOURce:CLOCK:OFFSet:MODE
SOURce:CLOCK:OFFSet:LVALue
SOURce:CLOCK:OFFSet:PVALue (Add/Drop Test Option Only)
SOURce:DATA:TELEcom:SOURce
SOURce:DATA:TELEcom:STRUcture
SOURce:DATA:TELEcom:CHANnel
SOURce:DATA:TELEcom:PAYLoad:MAPPing
SOURce:DATA:TELEcom:PAYLoad:PATtern
SOURce:DATA:TELEcom:PAYLoad:PATtern:UBYTE
SOURce:DATA:TELEcom:OVERhead:APS
SOURce:DATA:TELEcom:OVERhead:INSert
SOURce:DATA:TELEcom:POVerhead:INSert
SOURce:DATA:TELEcom:POVerhead:TRAcE
SOURce:DATA:TELEcom:ERRor:ENABle

**Table C-1: Commands returned by \*LRN? (Cont.)**

<b>Command</b>
SOURce:DATA:TELEcom:ERRor:TYPE
SOURce:DATA:TELEcom:ERRor:RATE
SOURce:DATA:TELEcom:ALARm
SOURce:DATA:TELEcom:FAILure:TYPE
SOURce:DATA:TELEcom:POINter:MODE
SOURce:DATA:TELEcom:POINter:NDFlag
SOURce:DATA:TELEcom:POINter:DIRection
SOURce:DATA:TELEcom:POINter:RATE
SOURce:DATA:TELEcom:POINter:NBURst
SOURce:DATA:TELEcom:POINter:SBITs
SOURce:DATA:TELEcom:POINter:SEQuence:TYPE
SOURce:DATA:TELEcom:POINter:SEQuence:DIRection
SOURce:DATA:TELEcom:POINter:SEQuence:IPERiod
SOURce:DATA:TELEcom:POINter:SEQuence:CPEriod
SOURce:DATA:TELEcom:POINter:SEQuence:RATE
SOURce:DATA:TELEcom:JITter:MODE (jitter/wander option 14 only)
SOURce:DATA:TELEcom:JITter:SOURce (jitter/wander option 14 only)
SOURce:DATA:TELEcom:JITter:CLOCK:RATE (jitter/wander option 14 only)
SOURce:DATA:TELEcom:JITter:CLOCK:OFFSet (jitter/wander option 14 only)
SOURce:DATA:TELEcom:JITter:AMPLitude (jitter/wander option 14 only)
SOURce:DATA:TELEcom:JITter:FREQuency (jitter/wander option 14 only)
SOURce:DATA:TELEcom:TRIButary:CHANnel (Add/Drop Test Option Only)
SOURce:DATA:TELEcom:TRIButary:MAPPing (Add/Drop Test Option Only)
SOURce:DATA:TELEcom:TRIButary:FRAMing (Add/Drop Test Option Only)
SOURce:DATA:TELEcom:TRIButary:PATTern (Add/Drop Test Option Only)
SOURce:DATA:TELEcom:TRIButary:PATTern:UWORD (Add/Drop Test Option Only)
SOURce:DATA:TELEcom:TRIButary:PATTern:UWORD:LENGth (Add/Drop Test Option Only)
SOURce:DATA:TELEcom:TRIButary:BACKground:PATTern (Add/Drop Test Option Only)
SOURce:DATA:TELEcom:TRIButary:ADD (Add/Drop Test Option Only)
SOURce:DATA:TELEcom:TRIButary:POVerhead:TRACe (Add/Drop Test Option Only)
SOURce:DATA:TELEcom:TRIButary:ERRor (Add/Drop Test Option Only)
SOURce:DATA:TELEcom:TRIButary:ALARm (Add/Drop Test Option Only)
SOURce:DATA:TELEcom:TRIButary:FAILure (Add/Drop Test Option Only)

Table C-1: Commands returned by \*LRN? (Cont.)

Command
SOURce:DATA:TELEcom:TRIButary:POINter:MODE (Add/Drop Test Option Only)
SOURce:DATA:TELEcom:TRIButary:POINter:NDFLag (Add/Drop Test Option Only)
SOURce:DATA:TELEcom:TRIButary:POINter:DIRection (Add/Drop Test Option Only)
SOURce:DATA:TELEcom:TRIButary:POINter:RATE (Add/Drop Test Option Only)
SOURce:DATA:TELEcom:TRIButary:POINter:NBURst (Add/Drop Test Option Only)
SOURce:DATA:TELEcom:TRIButary:POINter:SEQUence:TYPE (Add/Drop Test Option Only)
SOURce:DATA:TELEcom:TRIButary:POINter:SEQUence:DIRection (Add/Drop Test Option Only)
SOURce:DATA:TELEcom:TRIButary:POINter:SEQUence:IPERiod (Add/Drop Test Option Only)
SOURce:DATA:TELEcom:TRIButary:POINter:SEQUence:CPERiod (Add/Drop Test Option Only)
SOURce:DATA:TELEcom:TRIButary:POINter:SEQUence:RATE (Add/Drop Test Option Only)
INPUT1:TELEcom:RATE
INPUT1:TELEcom:TYPE
INPUT1:TELEcom:LEVel
INPUT2:TELEcom:TERMinator (Add/Drop Test Option Only)
INPUT2:TELEcom:LEVel (Add/Drop Test Option Only)
INPUT3:TELEcom:RATE (Add/Drop Test Option Only)
INPUT3:TELEcom:LEVel (Add/Drop Test Option Only)
SENSe:DATA:TELEcom:SOURce
SENSe:DATA:TELEcom:STRUcture
SENSe:DATA:TELEcom:CHANnel
SENSe:DATA:TELEcom:PAYLoad:MAPPing
SENSe:DATA:TELEcom:PAYLoad:PATTern
SENSe:DATA:TELEcom:PAYLoad:PATTern:UBYTE
SENSe:DATA:TELEcom:TRIButary:CHANnel (Add/Drop Test Option Only)
SENSe:DATA:TELEcom:TRIButary:MAPPing (Add/Drop Test Option Only)
SENSe:DATA:TELEcom:TRIButary:FRAMing (Add/Drop Test Option Only)
SENSe:DATA:TELEcom:TRIButary:DEMULTiplex:CHANnel (Performs no operation)
SENSe:DATA:TELEcom:TRIButary:DEMULTiplex:FRAMing (Performs no operation)
SENSe:DATA:TELEcom:TRIButary:PATTern (Add/Drop Test Option Only)
SENSe:DATA:TELEcom:TRIButary:PATTern:UWORD (Add/Drop Test Option Only)
SENSe:DATA:TELEcom:TRIButary:PATTern:UWORD:LENGth (Add/Drop Test Option Only)
SENSe:DATA:TELEcom:TRIButary:DROP (Add/Drop Test Option Only)

**Table C-1: Commands returned by \*LRN? (Cont.)**

<b>Command</b>
SENSe:DATA:TELEcom:TEST:DURation
SENSe:DATA:TELEcom:TEST:HISTory:RESolution
SENSe:DATA:TELEcom:OVERhead:DROP
SENSe:DATA:TELEcom:POVerhead:DROP
SENSe:DATA:TELEcom:TEST:MODE (jitter/wander option 14 only)
SENSe:DATA:TELEcom:TEST:JITter:TYPE TOLerance (jitter/wander option 14 only)
SENSe:DATA:TELEcom:TEST:JITter:TOLerance:MASK (jitter/wander option 14 only)
SENSe:DATA:TELEcom:TEST:JITter:TOLerance:FREQUency:STARt (jitter/wander option 14 only)
SENSe:DATA:TELEcom:TEST:JITter:TOLerance:FREQUency:END (jitter/wander option 14 only)
SENSe:DATA:TELEcom:TEST:JITter:TOLerance:SAMPles (jitter/wander option 14 only)
SENSe:DATA:TELEcom:TEST:JITter:TOLerance:METHod (jitter/wander option 14 only)
SENSe:DATA:TELEcom:TEST:JITter:TRANSFer:MASK (jitter/wander option 14 only)
SENSe:DATA:TELEcom:TEST:JITter:TRANSFer:FREQUency:STARt (jitter/wander option 14 only)
SENSe:DATA:TELEcom:TEST:JITter:TRANSFer:FREQUency:END (jitter/wander option 14 only)
SENSe:DATA:TELEcom:TEST:JITter:TRANSFer:SAMPles (jitter/wander option 14 only)
SENSe:DATA:TELEcom:TEST:JITter:OUTPUT:DURation (jitter/wander option 14 only)
SENSe:DATA:TELEcom:TEST:JITter:POINter:SEQUence:TYPE (jitter/wander option 14 only)
SENSe:DATA:TELEcom:JITter:MODE (jitter/wander option 14 only)
SENSe:DATA:TELEcom:JITter:SOURce (jitter/wander option 14 only)
SENSe:DATA:TELEcom:JITter:CLOCK:RATE (jitter/wander option 14 only)
SENSe:DATA:TELEcom:JITter:FILTer:TYPE (jitter/wander option 14 only)
SENSe:DATA:TELEcom:JITter:FILTer:HIGHBand (jitter/wander option 14 only)
SENSe:DATA:TELEcom:JITter:FILTer:FULLband:HPASs (jitter/wander option 14 only)
SENSe:DATA:TELEcom:JITter:RANGe (jitter/wander option 14 only)
SENSe:DATA:TELEcom:JITter:THREShold (jitter/wander option 14 only)
SENSe:DATA:TELEcom:JITter:POINter:THREShold (jitter/wander option 14 only)
INSTrument:COUPLing
HCOPY:ITEM
HCOPY:TITle
HCOPY:DEVice:LANGUage

## Appendix D: Default Parameter Values After \*RST

Table D-1 lists the default parameter values after the \*RST command is sent.

**Table D-1: Default parameter values after \*RST**

Command	Default Parameter Values
OUTPUT1:TELEcom:RATE	STM1
OUTPUT1:TELEcom:TYPE	ELECTrical
OUTPUT1:TELEcom:LEVel	XCONnect
OUTPUT2:TELEcom:TERMinator	BALanced (Add/Drop Test Option Only)
OUTPUT2:TELEcom:CODE	HDB3 (Add/Drop Test Option Only)
OUTPUT3:TELEcom:RATE	M34 (Add/Drop Test Option Only)
SOURce:CLOCK:SOURce	INTernal
SOURce:CLOCK:OFFSet:MODE	LOFFset
SOURce:CLOCK:OFFSet:LVALue	0.00
SOURce:CLOCK:OFFSet:PVALue	0.00
SOURce:DATA:TELEcom:SOURce	OUTPUT1
SOURce:DATA:TELEcom:STRUcture	AU4
SOURce:DATA:TELEcom:CHANnel	1
SOURce:DATA:TELEcom:PAYLoad:MAPPing	EQUIPPED
SOURce:DATA:TELEcom:PAYLoad:PATtern	PRBS23
SOURce:DATA:TELEcom:PAYLoad:PATtern:UBYTE	0
SOURce:DATA:TELEcom:OVERhead:PRESet	(sets overhead to values listed in Figure 2-14 in <i>Syntax and Commands</i> on page 2-32)
SOURce:DATA:TELEcom:OVERhead:APS	0
SOURce:DATA:TELEcom:OVERhead:INSert	NONE
SOURce:DATA:TELEcom:POVerhead:INSert	NONE
SOURce:DATA:TELEcom:POVerhead:TRAcE	" " (64 null characters)
SOURce:DATA:TELEcom:ERRor:ENABle	0
SOURce:DATA:TELEcom:ERRor:TYPE	SCV
SOURce:DATA:TELEcom:ERRor:RATE	1E-10
SOURce:DATA:TELEcom:ALARm	NONE
SOURce:DATA:TELEcom:FAILure:TYPE	NONE

Table D-1: Default parameter values after \*RST (Cont.)

Command	Default Parameter Values
SOURce:DATA:TELEcom:POINter:MODE	SINGLE
SOURce:DATA:TELEcom:POINter:VALue	522
SOURce:DATA:TELEcom:POINter:NDFlag	1
SOURce:DATA:TELEcom:POINter:DIRection	ALternate
SOURce:DATA:TELEcom:POINter:RATE	100
SOURce:DATA:TELEcom:POINter:NBUrst	2
SOURce:DATA:TELEcom:POINter:SBITs	0
SOURce:DATA:TELEcom:POINter:Sequence:TYPE	SINGLE
SOURce:DATA:TELEcom:POINter:Sequence:DIRection	UP
SOURce:DATA:TELEcom:POINter:Sequence:IPERiod	1
SOURce:DATA:TELEcom:POINter:Sequence:CPERiod	1
SOURce:DATA:TELEcom:POINter:Sequence:RATE	30000
SOURce:DATA:TELEcom:TRIButary:CHANnel	1 (Add/Drop Test Option Only)
SOURce:DATA:TELEcom:TRIButary:MAPPING	TUASYNC (Add/Drop Test Option Only)
SOURce:DATA:TELEcom:TRIButary:FRAMing	UNFRamed (Add/Drop Test Option Only)
SOURce:DATA:TELEcom:TRIButary:PATtern	PRB15PRBS23 (Add/Drop Test Option Only)
SOURce:DATA:TELEcom:TRIButary:PATtern:UWORD	0 (Add/Drop Test Option Only)
SOURce:DATA:TELEcom:TRIButary:PATtern:UWORD:LENGth	1 (Add/Drop Test Option Only)
SOURce:DATA:TELEcom:TRIButary:BACKground:PATtern	PRBS (Add/Drop Test Option Only)
SOURce:DATA:TELEcom:TRIButary:ADD	0 (Add/Drop Test Option Only)
SOURce:DATA:TELEcom:TRIButary:POVerhead:TRACe	TEK CTS750
SOURce:DATA:TELEcom:TRIButary:ERRor	NONE (Add/Drop Test Option Only)
SOURce:DATA:TELEcom:TRIButary:ALARm	NONE (Add/Drop Test Option Only)
SOURce:DATA:TELEcom:TRIButary:FAILure	NONE (Add/Drop Test Option Only)
SOURce:DATA:TELEcom:TRIButary:POINter:MODE	SINGLE (Add/Drop Test Option Only)
SOURce:DATA:TELEcom:TRIButary:POINter:NDFLAG	1 (Add/Drop Test Option Only)
SOURce:DATA:TELEcom:TRIButary:POINter:DIRection	ALternate (Add/Drop Test Option Only)
SOURce:DATA:TELEcom:TRIButary:POINter:RATE	100 (Add/Drop Test Option Only)

Table D-1: Default parameter values after \*RST (Cont.)

Command	Default Parameter Values
SOURce:DATA:TELEcom:TRIButary:POINter:Nburst	2 (Add/Drop Test Option Only)
SOURce:DATA:TELEcom:TRIButary:POINter:SEQuence:TYPE	SINGle (Add/Drop Test Option Only)
SOURce:DATA:TELEcom:TRIButary:POINter:SEQuence:DIRection	UP (Add/Drop Test Option Only)
SOURce:DATA:TELEcom:TRIButary:POINter:SEQuence:IPERiod	1 (Add/Drop Test Option Only)
SOURce:DATA:TELEcom:TRIButary:POINter:SEQuence:CPEriod	1 (Add/Drop Test Option Only)
SOURce:DATA:TELEcom:TRIButary:POINter:SEQuence:RATE	30000 (Add/Drop Test Option Only)
SOURce:DATA:TELEcom:TRIButary:MODE	MANual (Add/Drop Test Option Only)
SOURce:DATA:TELEcom:JITter:MODE	OFF (SDH/PDH Jitter/Wander Test Option Only)
SOURce:DATA:TELEcom:JITter:SOURce	LINE (SDH/PDH Jitter/Wander Test Option Only)
SOURce:DATA:TELEcom:JITter:CLOCK:RATE	M2 (SDH/PDH Jitter/Wander Test Option Only)
SOURce:DATA:TELEcom:JITter:CLOCK:OFFSet	0.0 (SDH/PDH Jitter/Wander Test Option Only)
SOURce:DATA:TELEcom:JITter:AMPLitude	1.00 (SDH/PDH Jitter/Wander Test Option Only)
SOURce:DATA:TELEcom:JITter:FREQuency	10.0 (SDH/PDH Jitter/Wander Test Option Only)
INPUT1:TELEcom:RATE	STM1
INPUT1:TELEcom:TYPE	ELECTrical
INPUT1:TELEcom:LEVel	XCONnect
INPUT2:TELEcom:TERMinator	BALanced (Add/Drop Test Option Only)
INPUT2:TELEcom:LEVel	NORMal (Add/Drop Test Option Only)
INPUT3:TELEcom:RATE	M34 (Add/Drop Test Option Only)
INPUT3:TELEcom:LEVel	NORMal (Add/Drop Test Option Only)
SENSe:DATA:TELEcom:SOURce	INPUT1
SENSe:DATA:TELEcom:STRUcture	AU4
SENSe:DATA:TELEcom:CHANnel	1

Table D-1: Default parameter values after \*RST (Cont.)

Command	Default Parameter Values
SENSe:DATA:TELEcom:PAYLoad:MAPPing	EQUIPPed
SENSe:DATA:TELEcom:PAYLoad:PATtern	PRBS23
SENSe:DATA:TELEcom:PAYLoad:PATtern:UBYTE	0
SENSe:DATA:TELEcom:TRIButary:CHANnel	1 (Add/Drop Test Option Only)
SENSe:DATA:TELEcom:TRIButary:MAPPing	TUASYNC (Add/Drop Test Option Only)
SENSe:DATA:TELEcom:TRIButary:FRAMing	UNFRamed (Add/Drop Test Option Only)
SENSe:DATA:TELEcom:TRIButary:Demultiplex:CHANnel	1 (Performs no operation)
SENSe:DATA:TELEcom:TRIButary:Demultiplex:FRAMing	UNFRamed (Performs no operation)
SENSe:DATA:TELEcom:TRIButary:PATtern	PRBS23 (Add/Drop Test Option Only)
SENSe:DATA:TELEcom:TRIButary:PATtern:UWORD	0 (Add/Drop Test Option Only)
SENSe:DATA:TELEcom:TRIButary:PATtern:UWORD:LENGth	1 (Add/Drop Test Option Only)
SENSe:DATA:TELEcom:TRIButary:DROP	0 (Add/Drop Test Option Only)
SENSe:DATA:TELEcom:TEST:DURation	0,0,0,0
SENSe:DATA:TELEcom:TEST:HISTory:RESolution	MIN1
SENSe:DATA:TELEcom:OVERhead:DROP	NONE
SENSe:DATA:TELEcom:POVerhead:DROP	NONE
SENSe:DATA:TELEcom:MEASure:STESts:	(all four commands set to NONE)
SENSe:DATA:TELEcom:JITter:SOURce	LINE (SDH/PDH Jitter/Wander Test Option Only)
SENSe:DATA:TELEcom:JITter:MODE	PTP (SDH/PDH Jitter/Wander Test Option Only)
SENSe:DATA:TELEcom:JITter:CLOCK:RATE	M2 (SDH/PDH Jitter/Wander Test Option Only)
SENSe:DATA:TELEcom:JITter:FILTer:TYPE	WIDE (SDH/PDH Jitter/Wander Test Option Only)
SENSe:DATA:TELEcom:JITter:FILTer:HIGHBand	STAN (SDH/PDH Jitter/Wander Test Option Only)
SENSe:DATA:TELEcom:JITter:FILTer:FULLband:HPASs	U10 (SDH/PDH Jitter/Wander Test Option Only)
SENSe:DATA:TELEcom:JITter:RANGe	NORM (SDH/PDH Jitter/Wander Test Option Only)
SENSe:DATA:TELEcom:JITter:THREshold	0.0 (SDH/PDH Jitter/Wander Test Option Only)



Table D-1: Default parameter values after \*RST (Cont.)

Command	Default Parameter Values
SENSe:DATA:TELEcom:JITter:POINter:THREshold	10.0 (SDH/PDH Jitter/Wander Test Option Only)
SENSe:DATA:TELEcom:TEST:MODE	NORM (SDH/PDH Jitter/Wander Test Option Only)
SENSe:DATA:TELEcom:TEST:JITter:TYPE	OUTPUT (SDH/PDH Jitter/Wander Test Option Only)
SENSe:DATA:TELEcom:TEST:JITter:TOLerance:MASK	G825 (SDH/PDH Jitter/Wander Test Option Only)
SENSe:DATA:TELEcom:TEST:JITter:TOLerance:FREQuency:STARt	1.25E-1 (SDH/PDH Jitter/Wander Test Option Only)
SENSe:DATA:TELEcom:TEST:JITter:TOLerance:FREQuency:END	130E+4 (SDH/PDH Jitter/Wander Test Option Only)
SENSe:DATA:TELEcom:TEST:JITter:TOLerance:SAMPles	4 (SDH/PDH Jitter/Wander Test Option Only)
SENSe:DATA:TELEcom:TEST:JITter:TOLerance:METhod	ONSET_ERR (SDH/PDH Jitter/Wander Test Option Only)
SENSe:DATA:TELEcom:TEST:JITter:TRANSFer:MASK	TYPEA (SDH/PDH Jitter/Wander Test Option Only)
SENSe:DATA:TELEcom:TEST:JITter:TRANSFer:FREQuency:STARt	10.0 (SDH/PDH Jitter/Wander Test Option Only)
SENSe:DATA:TELEcom:TEST:JITter:TRANSFer:FREQuency:END	130.E+3 (SDH/PDH Jitter/Wander Test Option Only)
SENSe:DATA:TELEcom:TEST:JITter:TRANSFer:SAMPles	4 (SDH/PDH Jitter/Wander Test Option Only)
SENSe:DATA:TELEcom:TEST:JITter:OUTPUT:DURation	1,0 (SDH/PDH Jitter/Wander Test Option Only)
SENSe:DATA:TELEcom:TEST:JITter:POINter:SEQuence:TYPE	SINALT (SDH/PDH Jitter/Wander Test Option Only)
INSTrument:COUPLing	NONE
INITiate	(executed)
SYSTem:BEEPper:CONTRol	0
SYSTem:HEADers	1 (ON)
SYSTem:MODE	SDH
SYSTem:SDDescription	" "
SYSTem:VERBose	1 (ON)
DISPlay:BRIGHtness	1.00
HCOPy:DEVice:LANGUage	TEK

**Table D-1: Default parameter values after \*RST (Cont.)**

<b>Command</b>	<b>Default Parameter Values</b>
HCOPY:ITEM	SUMMARY
HCOPY:TITLE	0

# Glossary

## **AIS**

An acronym for Alarm Indication Signal. An AIS is used to alert downstream equipment that an upstream failure has been detected.

## **APS**

An acronym for Automatic Protection Switching.

## **ASCII**

An acronym for American Standard Code for Information Interchange.

## **AU**

An acronym for Administrative Unit.

## **AU-4**

Virtual Container (VC) plus the Transport Overhead pointers.

## **BBE**

An acronym for Background Block Error. A Background Block Error is an errored block that occurs outside of a Severely Errored Second.

## **BER**

An acronym for Bit Error Ratio (or Rate). The principal measure of quality of a digital transmission system. BER is defined as:

$$BER = \frac{\text{Number of Errors}}{\text{Total Number of Bits}}$$

BER is usually expressed as a negative exponent. For example, a BER of  $10^{-7}$  means that 1 bit out of  $10^7$  bits is in error.

## **BIP**

An acronym for Bit Interleaved Parity. A method used to monitor errors in the transmitted signal.

## **Bit Error**

An incorrect bit. Also known as a coding violation.

## **BITS**

An acronym for Building Integrated Timing Supply.

## **Chained Commands and Queries**

Commands and queries grouped together into a single message to be sent to the instrument. Each command and query in the chained message must be separated by a semicolon (;).

**COFA**

An acronym for Change of Frame Alignment.

**Command**

Specifies an action for the instrument to perform.

**Common Commands**

See IEEE 488.2 Common Commands.

**CV**

An acronym for Coding Violation.

**dB**

The symbol for decibels.

**dBm**

The symbol for power level in decibels relative to 1 mW.

**DM**

An acronym for Degraded Minute. A minute with a BER greater than  $10^{-6}$ .

**EB**

An acronym for Errored Block. An Errored Block is a block with one or more bit errors, usually applied to a single SDH frame.

**EFS**

An acronym for Error Free Seconds.

**Equipped**

An interpretation of mapping; the C2 byte in the path overhead is set to one.

**ES**

An acronym for Errored Second. A second with at least one error.

**Event Status Enable Register**

The register that controls which events are summarized in the event status bit (bit 5) of the Status Byte Register.

**E1, E2, E3, E4**

The preferred names for the ITU 2 Mb/s, 8 Mb/s, 32 Mb/s, and 140 Mb/s tributary signals.

**FEBE**

An acronym for Far End Block Error. An indication returned to the transmitting LTE that an errored block has been detected at the receiving LTE.

**FERF**

An acronym for Far End Receive Failure. A FERF indicates to the transmitting LTE that the receiving LTE has detected an incoming line failure or is receiving a Line AIS.

**Functional Block**

A part of the instrument that performs a specific function. Examples are the Transmitter and Receiver.

**IEEE 488.21 Common Commands**

The set of commands and queries defined by the ANSI/IEEE Standard 488.2.

**ITU**

An acronym for the International Telecommunication Union.

**Line Alarm Indication Signal (AIS)**

A Line AIS is generated by Section Terminating Equipment upon Loss of Signal or Loss of Frame.

**Line Coding Violation (CV)**

The sum of the BIP errors detected at the Line layer. Line CVs are collected using the BIP codes in the B2 bytes of the Line Overhead.

**Line Errored Second (ES)**

A second during which at least one Line CV occurred, or a second during which the line was in the Line AIS state.

**Line Far End Receive Failure (FERF)**

An indication returned to a transmitting LTE from the receiving LTE that a Line AIS or incoming line failure has been detected.

**Line Overhead (LOH)**

Controls the payload information using the section layer and provides alarm indications, error monitoring, and message signalling between two LTEs.

**Line Severely Errored Second (SES)**

A second with N or more Line CVs, or a second during which the line was in the Line AIS state. The value of N varies with the transmit rate, but corresponds to a  $2 \times 10^{-7}$  BER.

**LOF**

An acronym for Loss of Frame.

**LOP**

An acronym for Loss of Pointer.

**LOS**

An acronym for Loss of Signal.

**LTE**

An acronym for Line Terminating Equipment.

**Mapping**

The process of placing a tributary signal into an SDH AU.

**Mb/s**

Megabits per second.

**MS**

An acronym for Multiplexer Section.

**NE**

An acronym for Network Element.

**Normal Mode**

A mode of operation in which the Transmitter and the Receiver operate independently.

**OOF**

An acronym for Out of Frame.

**OPC Bit (Operation Complete Bit)**

A bit in the Standard Event Status Register that is set when certain commands and queries complete execution.

**Output Queue**

The queue that stores query responses from the instrument.

**Pass/Fail Test**

A test measurement that is compared to predefined thresholds to determine a pass or fail condition of the test.

**Path Overhead (POH)**

A set of bytes allocated within the information payload to carry status and maintenance information between two network elements.

**Path Trace**

A 64-character sequence used to identify the communication path. The path trace is carried in the J1 byte over 64 repeating frames.

**POH**

An acronym for Path Overhead.

**PTE**

An acronym for Path Terminating Equipment.

**Query**

A message sent to the instrument that returns information about the state of the instrument.

**Receiver**

The functional block of the instrument that measures an incoming signal.

**RS**

An acronym for Regenerator Section.

**Rx**

An abbreviation for Receive.

**SCPI**

An acronym for Standard Commands for Programmable Instruments. A standard that provides guidelines for remote programming of instruments.

**SDH**

An acronym for Synchronous Digital Hierarchy.

**Section**

The portion of a transmission line between a Network Element (NE) and a Line Terminating Equipment (LTE) or two LTEs.

**Section Errored Second (ES)**

A second during which at least one Section CV or OOF/COFA event occurred, or a second during which the NE was (at any point during the second) in the LOS state.

**Section Overhead (SOH)**

A set of bytes allocated within each frame to carry framing and error monitoring information between an NE and LTE or between two LTEs. Part of the transport overhead.

**Service Request Enable Register**

The register that controls which bits in the Status Byte Register generate a service request

**SES**

An acronym for Severely Errored Seconds.

**Severely Errored Seconds (SES)**

A second with more than N CVs. N varies with the transmit rate but corresponds to a BER of  $2 \times 10^{-7}$ .

**SOH**

An acronym for Section Overhead.

**Standard Event Status Register**

The register that records many types of events that occur in the instrument such as execution error and operation complete.

**Status Byte Register**

The register that summarizes information from other registers in the Status and Event Reporting System.

**STE**

An acronym for Section Terminating Equipment.

**STM**

An acronym for Synchronous Transport Module.

**STM-N**

An acronym for Synchronous Transport Module-N (STM-1, -4, -16). The different STM-N rates for the SDH Signal Hierarchy are listed in the following table:

Electrical Signal	Data Rate (Mb/s)
STM-1	155.52
STM-4	622.08
STM-8	1244.16
STM-16	2488.32

**Subsystem Hierarchy Tree**

A graphical representation of a subsystem of commands and queries.

**System Error and Event Queue**

The queue that stores error and event messages.

**TE**

An acronym for Terminal Equipment.

**Through Mode**

The ability to retransmit the incoming signal and manipulate its contents.

**TOH**

An acronym for Transport Overhead.

**Transmitter**

The functional block of the instrument that generates a signal.

**Transport Overhead (TOH)**

A set of bytes allocated within each frame to carry operation, administration, and maintenance information from one end of the system to the other.

**Tributary**

The lower rate signal that is input to a multiplexer for combination (multiplexing) with other low rate signals to form a higher rate signal.

**TU**

An acronym for Tributary Unit. A structure (not a signal) designed for transport and switching of sub-AU-4 payloads. The TU sizes currently in use are TU-11, TU-12, and TU-3.

**TUG**

An acronym for Tributary Unit Group.

**Tx**

An abbreviation for Transmit.



**Unequipped**

An interpretation of mapping; the C2 byte in the path overhead is set to zero.

**VC**

An acronym for Virtual Container.

**Yellow Signal**

A code sent upstream to indicate that a failure condition has been declared downstream.



# Index

## A

abbreviating commands, queries, and parameters, 2-3

## C

### CALibrate

:EXECute, 2-308

:RESults?, 2-309

:SElect, 2-310

CALibrate Subsystem, 2-308

chaining commands and queries, 2-4

\*CLS, 2-311

command error messages, 3-8

Common Commands, 2-311

controlling responses to queries, 2-4

creating commands, 2-1

creating queries, 2-2

## D

decimal value tables, how to interpret, 2-12

device dependent error messages, 3-10

### DIAGnostic

:BUFFer:DATA?, 2-307

:BUFFer:INDex, 2-306

:BUFFer:SIZE?, 2-305

:EXECute, 2-301

:LOOP, 2-304

:RESults?, 2-303

:SElect, 2-302

Diagnostic Commands, 2-301

DIAGnostic Subsystem, 2-301

DISPlay Subsystem, 2-275

DISPlay:BRIGhtness, 2-275

## E

error messages, 3-8

command errors, 3-8

device dependent errors, 3-10

execution errors, 3-9

execution warning messages, 3-10

system events, 3-10

\*ESE, 2-312, 3-4

\*ESE?, 2-313, 3-4

\*ESR?, 2-314, 3-3

Event Reporting Process, 3-6

Event Reporting System, 3-1

Event Status Enable Register, 3-4

execution error messages, 3-9

execution warning messages, 3-10

## G

GPIB command synchronization, 3-7

## H

### HCOPY

:ABORt, 2-276

:DEVice:LANGUage, 2-278

:IMMediate, 2-277

:ITEM, 2-277

:TITLe, 2-279

HCOPY Subsystem, 2-276

## I

\*IDN?, 2-315

IEEE 488.2 Common Commands

\*CLS, 2-311

\*ESE, 2-312

\*ESE?, 2-313

\*ESR?, 2-314

\*IDN?, 2-315

\*LRN?, 2-315

\*OPC, 2-320

\*OPC?, 2-320

\*OPT?, 2-321

\*RCL, 2-321

\*RST, 2-316

\*SAV, 2-322

\*SRE, 2-317

\*SRE?, 2-318

\*STB?, 2-319

\*TST?, 2-323

\*WAI, 2-324

INITiate, 2-253

Input/Output Commands, 2-257

DISPlay Subsystem, 2-275

HCOPY Subsystem, 2-276

MMEMory Subsystem, 2-257

MMEMory:JITter Subsystem, 2-265

SYSTem:COMMunicate:SERial Subsystem, 2-280

INPUT1 Subsystem, 2-100

INPUT1:TELEcom  
   :LEVel, 2-102  
   :OPWR?, 2-103  
   :PVOLtage?, 2-104  
   :RATE, 2-100  
   :STATus?, 2-103  
   :TYPE, 2-101  
 INPUT2 Subsystem, 2-105  
 INPUT2:TELEcom  
   :LEVel, 2-105  
   :STATus?, 2-106  
   :TERMinator, 2-107  
 INPUT3 Subsystem, 2-108  
 INPUT3:TELEcom  
   :LEVel, 2-108  
   :RATE, 2-109  
   :STATus?, 2-110  
 Instrument Control Commands, 2-289  
   SYSTem Subsystem, 2-289  
 INSTRument Subsystem, 2-251  
 INSTRument:COUPLing, 2-251

## L

\*LRN?, 2-315

## M

messages. *See* error messages  
 MMEMory Subsystem, 2-257  
 MMEMory:DELEte  
   :RESults, 2-263  
   :SETTings, 2-258  
   :TEST, 2-260  
 MMEMory:DELEte:JITter  
   :OUTPUT, 2-273  
   :POINter, 2-274  
   :TOLerance, 2-272  
   :TRANSFer, 2-272  
 MMEMory:JITter Subsystem, 2-265  
 MMEMory:LOAD  
   :RESults, 2-264  
   :SETTings, 2-259  
   :TEST, 2-261  
 MMEMory:LOAD:JITter  
   :OUTPUT, 2-267  
   :POINter, 2-267  
   :TOLerance, 2-265  
   :TRANSFer, 2-266  
 MMEMory:STORE  
   :RESults, 2-262  
   :SETTings, 2-258

  :TEST, 2-260  
 MMEMory:STORE:JITter  
   :OUTPUT, 2-270  
   :POINter, 2-271  
   :TOLerance, 2-268  
   :TRANSFer, 2-269

## O

\*OPC, 2-320  
 OPC bit, 3-3, 3-4, B-1  
 \*OPC?, 2-320, 3-7  
 \*OPT?, 2-321  
 Output queue, 3-5  
 OUTPUT1 Subsystem, 2-14  
 OUTPUT1:TELEcom  
   :LEVel, 2-16  
   :RATE, 2-14  
   :TYPE, 2-15  
 OUTPUT2 Subsystem, 2-17  
 OUTPUT2:TELEcom  
   :CODE, 2-17  
   :TERMinator, 2-18  
 OUTPUT3 Subsystem, 2-19  
 OUTPUT3:TELEcom:RATE, 2-19

## P

parameter types, 2-2

## Q

Queue  
   Output, 3-5  
   System Error and Event, 3-5

## R

\*RCL, 2-321  
 Receive Commands, 2-99  
   INPUT1 Subsystem, 2-100  
   INPUT2 Subsystem, 2-105  
   INPUT3 Subsystem, 2-108  
   SENSe:DATA:TELEcom Subsystem, 2-111  
   SENSe:DATA:TELEcom:AUTOscan Subsystem,  
     2-228  
   SENSe:DATA:TELEcom:JITter Subsystem, 2-124,  
     2-241  
   SENSe:DATA:TELEcom:MEASure Subsystem,  
     2-169

- SENSe:DATA:TELEcom:MEASure:JITter Subsystem, 2-195
- SENSe:DATA:TELEcom:MEASure:STESTs Subsystem, 2-187
- SENSe:DATA:TELEcom:MEASure:TRIButary Subsystem, 2-217
- SENSe:DATA:TELEcom:MEASure:WANDer Subsystem, 2-211
- SENSe:DATA:TELEcom:OVERhead and POVerhead Subsystem, 2-163
- SENSe:DATA:TELEcom:TEST Subsystem, 2-118
- SENSe:DATA:TELEcom:TRIButary Subsystem, 2-229
- Register
  - Event Status Enable, 3-4
  - Service Request Enable, 3-2
  - Standard Event Status, 3-3
  - Status Byte, 3-1
- \*RST, 2-316
  
- S**
- \*SAV, 2-322
- SCPI commands and queries syntax, 2-1
- SENSe:DATA:TELEcom
  - :CHANnel, 2-114
  - :PAYLoad:MAPPING, 2-115
  - :PAYLoad:PATtern, 2-116
  - :PAYLoad:PATtern:UBYTE, 2-117
  - :SOURce, 2-111
  - :STATus?, 2-113
  - :STATus:PRESet, 2-114
  - :STRUcture, 2-112
- SENSe:DATA:TELEcom Subsystem, 2-111
- SENSe:DATA:TELEcom:AUTOscan, 2-228
- SENSe:DATA:TELEcom:AUTOscan Subsystem, 2-228
- SENSe:DATA:TELEcom:JITter
  - :CLOCK:RATE, 2-244
  - :FILTer:FULLband:HPASs, 2-247
  - :FILTer:HIGHBand, 2-246
  - :FILTer:TYPE, 2-245
  - :FREQuency:DELTA:CURrent?, 2-249
  - :FREQuency:RATE:CURrent?, 2-248
  - :MODE, 2-242
  - :POINter:THREshold, 2-250
  - :RANGe, 2-244
  - :SOURce, 2-243
  - :THREshold, 2-248
- SENSe:DATA:TELEcom:JITter Subsystem, 2-124, 2-241
- SENSe:DATA:TELEcom:MEASure Subsystem, 2-169
- SENSe:DATA:TELEcom:MEASure:ALARm queries, 2-179
- SENSe:DATA:TELEcom:MEASure:ANALysis queries, 2-176
- SENSe:DATA:TELEcom:MEASure:BUFFer, 2-182
- SENSe:DATA:TELEcom:MEASure:BUFFer:AVAIlable?, 2-183
- SENSe:DATA:TELEcom:MEASure:ERRor queries, 2-174
- SENSe:DATA:TELEcom:MEASure:INFORmation queries, 2-184
- SENSe:DATA:TELEcom:MEASure:JITTER
  - :FREQuency:CURrent?, 2-206
  - :FREQuency:CURrent:DELTA?, 2-206
  - :FREQuency:DRIFT:CURrent?, 2-204
  - :FREQuency:DRIFT:MAXimum?, 2-205
  - :FREQuency:MAXimum?, 2-207
  - :FREQuency:MAXimum:DELTA?, 2-208
  - :FREQuency:MINimum?, 2-209
  - :FREQuency:MINimum:DELTA?, 2-210
  - :HSEConds?, 2-202
  - :PEAK:NEGATIVE:CURrent?, 2-199
  - :PEAK:NEGATIVE:MAXimum?, 2-200
  - :PEAK:POSITIVE:CURrent?, 2-198
  - :PEAK:POSITIVE:MAXimum?, 2-199
  - :POINter:HSEConds?, 2-203
  - :PTPeak:CURrent?, 2-196
  - :PTPeak:MAXimum?, 2-197
  - :RMS:CURrent?, 2-201
  - :RMS:MAXimum?, 2-201
  - :STATus?, 2-196
  - :UNLSeconds?, 2-203
- SENSe:DATA:TELEcom:MEASure:JITter Subsystem, 2-195
- SENSe:DATA:TELEcom:MEASure:POINter queries, 2-180
- SENSe:DATA:TELEcom:MEASure:STESTs
  - :DESCRiption, 2-188
  - :DONE, 2-194
  - :ENABLE, 2-188
  - :RESUlts?, 2-193
  - :THREshold, 2-189
- SENSe:DATA:TELEcom:MEASure:STESTs Subsystem, 2-187
- SENSe:DATA:TELEcom:MEASure:TRIButary Subsystem, 2-217
- SENSe:DATA:TELEcom:MEASure:TRIButary:ALARm queries, 2-226
- SENSe:DATA:TELEcom:MEASure:TRIButary:ANALysis queries, 2-224

- SENSe:DATA:TELEcom:MEASure:TRIButary:ERRor queries, 2–222
- SENSe:DATA:TELEcom:MEASure:TSCAn?, 2–185
- SENSe:DATA:TELEcom:MEASure:WANDer
  - :PTPeak:NS?, 2–214
  - :PTPeak:UI?, 2–214
  - :SLIPS:BIT?, 2–212
  - :SLIPS:FRAME?, 2–213
  - :TIE:NS?, 2–215
  - :TIE:UI?, 2–216
- SENSe:DATA:TELEcom:MEASure:WANDer Subsystem, 2–211
- SENSe:DATA:TELEcom:OVERhead
  - :DATA?, 2–163
  - :DROP, 2–164
  - :POINter, 2–165
- SENSe:DATA:TELEcom:OVERhead and POverhead Subsystem, 2–163
- SENSe:DATA:TELEcom:POVerhead
  - :DATA?, 2–166
  - :DROP, 2–167
  - :TRACe?, 2–168
- SENSe:DATA:TELEcom:TEST
  - :DURation, 2–121
  - :HISTory:RESolution, 2–123
  - :MODE, 2–118
  - :STARt, 2–119
  - :STATus?, 2–120
  - :STIME?, 2–122
  - :STOP, 2–120
- SENSe:DATA:TELEcom:TEST Subsystem, 2–118
- SENSe:DATA:TELEcom:TEST:JITter
  - :STATus?, 2–126
  - :TYPE, 2–125
- SENSe:DATA:TELEcom:TEST:JITter:OUTPUT
  - :DURation, 2–151
  - :HIGHBand:DATA?, 2–154
  - :INFORmation?, 2–152
  - :WIDEBand:DATA?, 2–155
- SENSe:DATA:TELEcom:TEST:JITter:POINter
  - :HIGHBand:DATA?, 2–160
  - :INFORmation?, 2–156
  - :SEQuence:TYPE, 2–159
  - :WIDEBand:DATA?, 2–161
- SENSe:DATA:TELEcom:TEST:JITter:TOLerance
  - :ALLData?, 2–138
  - :DATA?, 2–137
  - :DATA:LENGth?, 2–136
  - :FREQuency:END, 2–131
  - :FREQuency:STARt, 2–130
  - :INFORmation?, 2–126
  - :MASK, 2–129
  - :MEASure, 2–133
  - :METHod, 2–132
  - :SAMPles, 2–135
  - :THREShold:DATA?, 2–134
  - :THREShold:STANdard?, 2–135
- SENSe:DATA:TELEcom:TEST:JITter:TRANSFer
  - :ALLData?, 2–150
  - :CALibrate:STATus?, 2–147
  - :DATA?, 2–148
  - :DATA:LENGth?, 2–148
  - :FREQuency:END, 2–144
  - :FREQuency:STARt, 2–143
  - :INFORmation?, 2–140
  - :MASK, 2–142
  - :SAMPles, 2–145
  - :STATE, 2–146
- SENSe:DATA:TELEcom:TRIButary
  - :CHANnel, 2–231
  - :DROP, 2–230
  - :FRAMing, 2–233
  - :MAPPing, 2–232
  - :PATTern, 2–234
  - :PATTern:UWORD, 2–235
  - :PATTern:UWORD:LENGth, 2–236
  - :POINter?, 2–237
  - :POVerhead:DATA?, 2–239
  - :POVerhead:TRACe?, 2–240
  - :STATus?, 2–237
- SENSe:DATA:TELEcom:TRIButary Subsystem, 2–229
- Service Request Enable Register, 3–2
- SOURce:CLOCK
  - :OFFSet:MODE, 2–22
  - :OFFSet:PVALue, 2–24
  - :OFFSet:VALue, 2–23
  - :SOURce, 2–21
  - :STATus?, 2–22
- SOURce:CLOCK Subsystem, 2–20
- SOURce:DATA:TELEcom
  - :CHANnel, 2–27
  - :PAYLoad:MAPPing, 2–28
  - :PAYLoad:PATTern, 2–29
  - :PAYLoad:PATTern:UBYTE, 2–30
  - :SOURce, 2–25
  - :STRUcture, 2–26
- SOURce:DATA:TELEcom Subsystem, 2–25
- SOURce:DATA:TELEcom:ALARm, 2–45
- SOURce:DATA:TELEcom:ERRor
  - :ENABle, 2–41
  - :IMMediate, 2–44
  - :RATE, 2–43
  - :TYPE, 2–42
- SOURce:DATA:TELEcom:ERRor, ALARm, and FAILure Subsystem, 2–41
- SOURce:DATA:TELEcom:FAILure:TYPE, 2–46

- SOURce:DATA:TELEcom:JITter
  - :AMPLitude, 2-97
  - :CLOCK:OFFSet, 2-95
  - :CLOCK:RATE, 2-94
  - :FREQuency, 2-96
  - :MODE, 2-92
  - :SOURce, 2-93
- SOURce:DATA:TELEcom:JITter Subsystem, 2-92
- SOURce:DATA:TELEcom:OVERhead
  - :ALLData, 2-35
  - :APS, 2-37
  - :DATA, 2-33
  - :INSert, 2-36
  - :PRESet, 2-33
- SOURce:DATA:TELEcom:OVERhead and POVerhead Subsystem, 2-31
- SOURce:DATA:TELEcom:POINter
  - :ACTIon, 2-53
  - :DIRectIon, 2-50
  - :MODE, 2-47
  - :NBURst, 2-51
  - :NDFLag, 2-49
  - :RATE, 2-51
  - :SBITs, 2-52
  - :VALue, 2-49
- SOURce:DATA:TELEcom:POINter Subsystem, 2-47
- SOURce:DATA:TELEcom:POINter:SEQuence
  - :ANOMaly:BTIME?, 2-61
  - :ANOMaly:NTIME?, 2-62
  - :CONTRol, 2-59
  - :CPErIod, 2-57
  - :CPErIod:LENGth?, 2-58
  - :DIRectIon, 2-53
  - :IPErIod, 2-56
  - :IPErIod:LENGth?, 2-57
  - :RATE, 2-54
  - :STATus?, 2-60
  - :TYPE, 2-55
- SOURce:DATA:TELEcom:POVerhead
  - :DATA, 2-38
  - :INSert, 2-39
  - :PRESet, 2-38
  - :TRACe, 2-40
- SOURce:DATA:TELEcom:TRIButary
  - :ADD, 2-63
  - :ALARm, 2-74
  - :BACKground:PATtern, 2-70
  - :CHANnel, 2-64
  - :ERROR, 2-73
  - :FAILure, 2-75
  - :FRAMing, 2-66
  - :MAPPing, 2-65
  - :PATtern, 2-67
  - :PATtern:UWORD, 2-68
  - :PATtern:UWORD:LENGth, 2-69
  - :POVerhead:DATA, 2-71
  - :POVerhead:TRACe?, 2-72
- SOURce:DATA:TELEcom:TRIButary Subsystem, 2-63
- SOURce:DATA:TELEcom:TRIButary:POINter
  - :ANOMaly:BTIME?, 2-90
  - :ANOMaly:NTIME?, 2-91
  - :DIRectIon, 2-80
  - :MODE, 2-77
  - :NBURst, 2-81
  - :NDFLag, 2-79
  - :RATE, 2-82
  - :SEQuence:CPErIod, 2-88
  - :SEQuence:CPErIod:LENGth?, 2-89
  - :SEQuence:DIRectIon, 2-83
  - :SEQuence:IPErIod, 2-86
  - :SEQuence:IPErIod:LENGth?, 2-87
  - :SEQuence:RATE, 2-84
  - :SEQuence:TYPE, 2-85
  - :VALue, 2-78
- SOURce:DATA:TELEcom:TRIButary:POINter Subsystem, 2-76
- \*SRE, 2-317, 3-2
- \*SRE?, 2-318, 3-2
- Standard Event Status Register, 3-3
- Status and Event Reporting Process, 3-6
- Status and Event Reporting System, 3-1
- Status and Events, 3-1
- Status Byte Register, 3-1
- status queries
  - INPUT2:TELEcom:STATus?, 2-106
  - INPUT3:TELEcom:STATus?, 2-110
  - SENSe:DATA:TELEcom:MEASure:INFORMa-tion:STATus?, 2-184
  - SENSe:DATA:TELEcom:STATus?, 2-113
  - SENSe:DATA:TELEcom:TEST:STATus?, 2-120
  - SENSe:DATA:TELEcom:TRIButary:STATus?, 2-237
  - SOURce:CLOCK:STATus?, 2-22
- \*STB?, 2-319, 3-1
- Subsystems
  - CALibrate, 2-308
  - DIAGnostic, 2-301
  - DISPlay, 2-275
  - HCOPY, 2-276
  - INPUT1, 2-100
  - INPUT2, 2-105
  - INPUT3, 2-108
  - INSTrument, 2-251
  - MMEMory, 2-257
  - MMEMory:JITter, 2-265
  - OUTPUT1, 2-14

OUTPUT2, 2-17  
 OUTPUT3, 2-19  
 SENSE:DATA:TELEcom, 2-111  
 SENSE:DATA:TELEcom:AUTOscan, 2-228  
 SENSE:DATA:TELEcom:JITter, 2-124, 2-241  
 SENSE:DATA:TELEcom:MEASure, 2-169  
 SENSE:DATA:TELEcom:MEASure:JITter, 2-195  
 SENSE:DATA:TELEcom:MEASure:STESTs, 2-187  
 SENSE:DATA:TELEcom:MEASure:TRIButary,  
 2-217  
 SENSE:DATA:TELEcom:MEASure:WANDer, 2-211  
 SENSE:DATA:TELEcom:OVERhead and POVer-  
 head, 2-163  
 SENSE:DATA:TELEcom:TEST, 2-118  
 SENSE:DATA:TELEcom:TRIButary, 2-229  
 SOURce:CLOCK, 2-20  
 SOURce:DATA:TELEcom, 2-25  
 SOURce:DATA:TELEcom:ERRor, ALARm, and  
 FAILure, 2-41  
 SOURce:DATA:TELEcom:JITter, 2-92  
 SOURce:DATA:TELEcom:OVERhead and  
 POVerhead, 2-31  
 SOURce:DATA:TELEcom:POINter, 2-47  
 SOURce:DATA:TELEcom:TRIButary, 2-63  
 SOURce:DATA:TELEcom:TRIButary:ERRor,  
 ALARm, FAILure, 2-73  
 SOURce:DATA:TELEcom:TRIButary:POINter, 2-76  
 SYSTem, 2-289  
 SYSTem:COMMunicate:SERial, 2-280  
 TRIGger, 2-253  
 Synchronizing GPIB commands, 3-7  
 \*OPC?, 3-7  
 SYSTem  
 :ABStouch, 2-299  
 :BEEPer:CONTrol, 2-296  
 :BEEPer:IMMediate, 2-295  
 :DATE, 2-290  
 :ERRor?, 2-289  
 :HEADers, 2-292  
 :KLOCK, 2-297  
 :MODE?, 2-291  
 :OWNer, 2-294  
 :SDEscription, 2-298  
 :SERial, 2-293  
 :SET?, 2-297  
 :TIME, 2-291  
 :USER, 2-295  
 :VERBose, 2-293

System Error and Event queue, 3-5  
 system events, 3-10  
 SYSTem Subsystem, 2-289  
 SYSTem:COMMunicate:SERial  
 :BAUD, 2-283  
 :CONTrol:DCD, 2-281  
 :CONTrol:RTS, 2-282  
 :PACE, 2-285  
 :PARity, 2-284  
 :PRESet, 2-280  
 :SBITs, 2-284  
 :TRANsmit:DELay, 2-286  
 :TRANsmit:TERMinator, 2-287  
 SYSTem:COMMunicate:SERial Subsystem, 2-280  
 SYSTem:ERRor?, 3-5

## T

Transmit Commands, 2-13  
 OUTPUT1 Subsystem, 2-14  
 OUTPUT2 Subsystem, 2-17  
 OUTPUT3 Subsystem, 2-19  
 SOURce:CLOCK Subsystem, 2-20  
 SOURce:DATA:TELEcom Subsystem, 2-25  
 SOURce:DATA:TELEcom:ERRor, ALARm, and  
 FAILure Subsystem, 2-41  
 SOURce:DATA:TELEcom:JITter Subsystem, 2-92  
 SOURce:DATA:TELEcom:OVERhead and  
 POVerhead Subsystem, 2-31  
 SOURce:DATA:TELEcom:POINter Subsystem, 2-47  
 SOURce:DATA:TELEcom:TRIButary Subsystem,  
 2-63  
 SOURce:DATA:TELEcom:TRIButary:POINter  
 Subsystem, 2-76  
 Transmitter/Receiver Setup Commands, 2-251  
 INSTrument Subsystem, 2-251  
 Trigger and Capture Commands, 2-253  
 TRIGger Subsystem, 2-253  
 TRIGger Subsystem, 2-253  
 TRIGger:IMMediate, 2-254  
 TRIGger:STATus?, 2-255  
 \*TST?, 2-323

## W

\*WAI, 2-324





