

User Manual

Tektronix

CMC251
1.3 GHz Frequency Counter
070-8527-03



Copyright © Tektronix, Inc. 1991. All rights reserved.

Tektronix products are covered by U.S. and foreign patents, issued and pending. Information in this publication supercedes that in all previously published material. Specifications and price change privileges reserved.

Tektronix, Inc., P.O. Box 1000, Wilsonville, OR 97070-1000

TEKTRONIX and TEK are registered trademarks of Tektronix, Inc.

WARRANTY

Tektronix warrants that this product will be free from defects in materials and workmanship for a period of one (1) year from the date of shipment. If any such product proves defective during this warranty period, Tektronix, at its option, either will repair the defective product without charge for parts and labor, or will provide a replacement in exchange for the defective product.

In order to obtain service under this warranty, Customer must notify Tektronix of the defect before the expiration of the warranty period and make suitable arrangements for the performance of service. Customer shall be responsible for packaging and shipping the defective product to the service center designated by Tektronix, with shipping charges prepaid. Tektronix shall pay for the return of the product to Customer if the shipment is to a location within the country in which the Tektronix service center is located. Customer shall be responsible for paying all shipping charges, duties, taxes, and any other charges for products returned to any other locations.

This warranty shall not apply to any defect, failure or damage caused by improper use or improper or inadequate maintenance and care. Tektronix shall not be obligated to furnish service under this warranty a) to repair damage resulting from attempts by personnel other than Tektronix representatives to install, repair or service the product; b) to repair damage resulting from improper use or connection to incompatible equipment; or c) to service a product that has been modified or integrated with other products when the effect of such modification or integration increases the time or difficulty of servicing the product.

THIS WARRANTY IS GIVEN BY TEKTRONIX WITH RESPECT TO THIS PRODUCT IN LIEU OF ANY OTHER WARRANTIES, EXPRESSED OR IMPLIED. TEKTRONIX AND ITS VENDORS DISCLAIM ANY IMPLIED WARRANTIES OF MERCHANTABILITY OR FITNESS FOR A PARTICULAR PURPOSE. TEKTRONIX' RESPONSIBILITY TO REPAIR OR REPLACE DEFECTIVE PRODUCTS IS THE SOLE AND EXCLUSIVE REMEDY PROVIDED TO THE CUSTOMER FOR BREACH OF THIS WARRANTY. TEKTRONIX AND ITS VENDORS WILL NOT BE LIABLE FOR ANY INDIRECT, SPECIAL, INCIDENTAL, OR CONSEQUENTIAL DAMAGES IRRESPECTIVE OF WHETHER TEKTRONIX OR THE VENDOR HAS ADVANCE NOTICE OF THE POSSIBILITY OF SUCH DAMAGES.



Table of Contents

General Safety Summary	iii
Getting Started	1
Preparing the Frequency Counter for Use	2
Front Panel	3
Rear Panel	6
Reference	9
Making Frequency Measurements	9
Frequencies Below 10 MHz	9
Frequencies Below 100 MHz	10
Frequencies Between 80 MHz and 1.3 GHz	11
Making Period Measurements	11
Making Pulse-Width Measurements	13
Remote Control of Pulse-Width Measurements	14
Counting Events	15
Remote Control of TOTAL Mode	16
Checking Instrument Operation	17
Appendix A: Specifications	19
Appendix B: Maintenance	25
Cleaning	25
Preparing for Shipment	25
Troubleshooting	26
No Display with Power On	26
Appendix C: Replaceable Parts	27
Standard Accessories	27
Optional Accessories	27

List of Tables

Table 1: A or B Channel Input	9
Table 2: Selecting Features For Channel A (1 Hz to 10 MHz)	10
Table 3: Selecting Features For Channel A (10 MHz to 100 MHz)	10
Table 4: Gate Time Versus Resolution for Channel A	11
Table 5: Gate Time Versus Resolution for Channel B	11
Table 6: Period Measurements	12
Table 7: Resolution For Period Measurements	12
Table 8: Pulse Width Measurements	13
Table 9: Resolution for Pulse Measurements	14
Table 10: Warranted Characteristics	19
Table 11: Certifications and Compliances	23
Table 12: Typical Characteristics	23
Table 13: Standard Accessories	27
Table 14: Optional Accessories	27
Table 15: Accessory Power Cords	28



General Safety Summary

Review the following safety precautions to avoid injury and prevent damage to this product or any products connected to it.

Injury Precautions

Use Proper Power Cord

To avoid fire hazard, use only the power cord specified for this product.

Avoid Electric Overload

To avoid electric shock or fire hazard, do not apply a voltage to a terminal that is outside the range specified for that terminal.

Ground the Product

This product is grounded through the grounding conductor of the power cord. To avoid electric shock, the grounding conductor must be connected to earth ground. Before making connections to the input or output terminals of the product, ensure that the product is properly grounded.

Do Not Operate Without Covers

To avoid electric shock or fire hazard, do not operate this product with covers or panels removed.

Use Proper Fuse

To avoid fire hazard, use only the fuse type and rating specified for this product.

General Safety Summary

Do Not Operate in Wet/Damp Conditions

To avoid electric shock, do not operate this product in wet or damp conditions.

Do Not Operate in Explosive Atmosphere

To avoid injury or fire hazard, do not operate this product in an explosive atmosphere.

Product Damage Precautions

Use Proper Voltage Setting

Before applying power, ensure that the line selector is in the proper position for the power source being used.

Provide Proper Ventilation

To prevent product overheating, provide proper ventilation.

Do Not Operate With Suspected Failures

If you suspect there is damage to this product, have it inspected by qualified service personnel.

Safety Terms and Symbols

Terms in This Manual

These terms may appear in this manual:



WARNING. Warning statements identify conditions or practices that could result in injury or loss of life.

General Safety Summary



CAUTION. Caution statements identify conditions or practices that could result in damage to this product or other property.

Terms on the Product

These terms may appear on the product:

DANGER indicates an injury hazard immediately accessible as you read the marking.

WARNING indicates an injury hazard not immediately accessible as you read the marking.

CAUTION indicates a hazard to property including the product.

Symbols on the Product

The following symbols may appear on the product:



DANGER
High Voltage



Protective Ground
(Earth) Terminal



ATTENTION
Refer to
Manual



Double
Insulated

Certifications and Compliances

CSA Certified Power Cords

CSA Certification includes the products and power cords appropriate for use in the North America power network. All other power cords supplied are approved for the country of use.

General Safety Summary



Getting Started

The Tektronix CMC251 Frequency Counter can make the following frequency-related measurements:

- Frequency measurements up to 1.3 GHz
- Period measurements at rates up to 25 MHz
- Period averaging of up to 1000 events
- Pulse measurements up to 0.25 μ s
- Event counting

The 10 MHz internal time base (using a highly stabilized crystal oscillator) provides a single-shot resolution of 100 ns. Measurement results are displayed using an eight digit display, automatically placing the decimal appropriately.

The CMC251 Frequency Counter has a locking, multiposition handle that folds under the instrument. The instrument is delivered with a 115 V power cord, an installed fuse for 115 V operation, and this manual.

Preparing the Frequency Counter for Use

Check the following items prior to operating the frequency counter for the first time (see Figure 1 for locations of items 1 through 3):

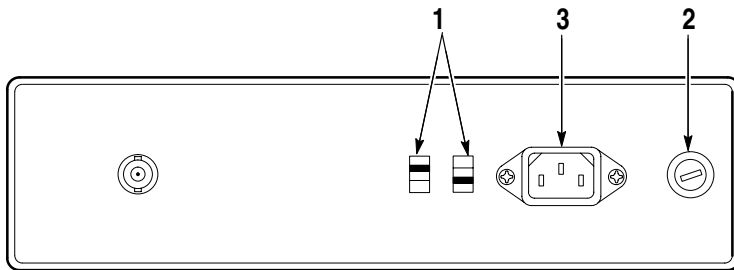

Figure 1: Line Voltage Selectors, Power Input, and Fuse Locations



CAUTION. To prevent damage to the instrument, set the line voltage selectors to the proper voltage setting and install the correct line voltage fuse before operating the equipment.

1. Set the line voltage selectors to the input line voltage. These selectors connect internal wiring for various line voltages. This product is intended to operate from a power source that does not supply more than 250 V_{RMS} between the supply conductors or between either supply conductor and ground. For line voltage ranges, refer to *Appendix A: Specifications* on page 19.



WARNING. To prevent electrical shock, unplug the power cord and disconnect the signal input cable from any signal source before checking or replacing the fuse.

2. Check that the correct line fuse is installed. The line fuse provides protection if the equipment malfunctions or an overload occurs. Refer to *Appendix C: Replaceable Parts* on page 27 for fuse part numbers.



WARNING. To prevent electrical shock, connect the power cord to a properly grounded power source. The outside (ground) of this connector is connected through the equipment to the power source ground. Do not remove the ground lug from the power cord for any reason.

3. Connect the input power cord. Use only the power cords specified for this equipment. Refer to *Appendix C: Replaceable Parts* on page 27 for power cord part numbers.

Front Panel

Figure 2 shows the front panel controls, connectors, and indicators with brief descriptions of the items following the figure.

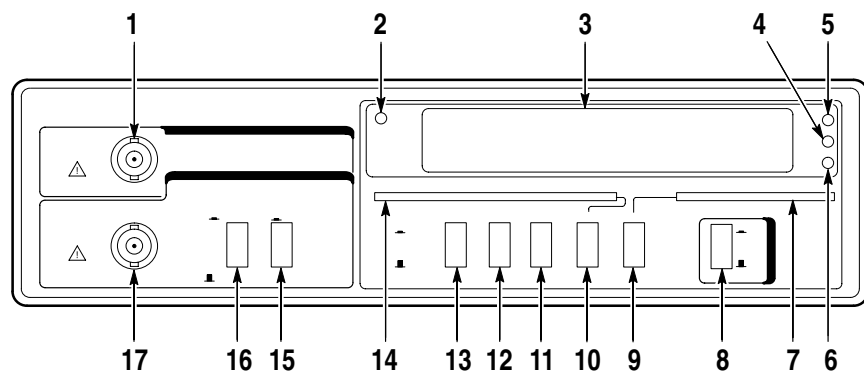

Figure 2: Front Panel Controls, Connectors, and Indicators



CAUTION. To avoid the risk of fire or possible damage to the CMC251, be sure that the equipment generating the signal is properly grounded before you make any connections to the inputs.

1. CHANNEL B INPUT Button. Use this input connector to measure signals with a repetition rate from 80 MHz to 1.3 GHz.

2. **OVERRANGE Indicator.** Lights when frequencies above the specified limits are applied to either channel.
3. **Display.** The display area provides measurement information on the digital display. Single LEDs indicate the units and conditions of the display.
4. **kHz/ μ s Indicator.** Lights when a frequency mode is selected and the PRESCALE button is in its out position, indicating that the reading is in kilohertz. When the period or pulse mode is selected, the LED lights to indicate the reading is in microseconds.
5. **MHz Indicator.** Lights when a frequency mode is selected and the PRESCALE button is pressed in, indicating that the reading is in megahertz.
6. **GATE Indicator.** Lights while the frequency counter is making a measurement. The LED extinguishes when updating the display.
7. **Gate Resolution Indicators.** These LEDs light to indicate the present gate resolution settings (X1, X10, X100, or X1000).
8. **POWER Switch.** Powers the instrument on and off.
9. **GATE Button.** Determines the display's degree of resolution by setting the gate time (the amount of time the counter uses to derive its displayed value). The selected resolution is indicated by the lighted LED. Each press of the button changes the degree of resolution to the next level.
10. **FUNC Button.** Determines the operating mode of the CMC251 Frequency Counter.
11. **HOLD Button.** Stops or locks the display when pressed in. Toggling the button to its out position allows the measurement to continue. When using the TOTAL mode, pressing the HOLD button freezes the display but event counting continues.
12. **RESET Button.** Sets the display to all zeros; new measurements will be displayed after the button is released.

13. **PRESCALE Button.** Divides the frequency of the signal applied to CHANNEL A INPUT by a factor of ten and sets the measurement units indicator to either MHz or kHz/ μ s. When pushed in, frequencies up to 100 MHz or periods up to 0.04 μ s can be measured. In the out position, frequencies up to 10 MHz or periods up to 0.4 μ s can be measured.
14. **Mode Indicators.** These LEDs light to indicate the present mode settings. One of the following modes is indicated:
 - **FREQ A**—The Frequency A mode measures the repetition rate of the signal applied to the CHANNEL A INPUT. In this mode, measurements from 1 Hz to 100 MHz can be made.
 - **FREQ B**—The Frequency B mode measures the repetition rate of the signal applied to the CHANNEL B INPUT. In this mode, measurements from 80 MHz to 1.3 GHz can be made.
 - **PERIOD A**—The Period A mode measures the time it takes for one cycle of the signal applied to CHANNEL A INPUT to be completed.
 - **PULSE A**—The Pulse A mode measures the width of the positive pulses of the signal applied to CHANNEL A INPUT. The Pulse mode can also measure the negative pulse of the input signal when using the external control input connector located on the rear panel. See *Making Pulse-Width Measurements* on page 13 for a description of its use.
 - **TOTAL**—The Totalize mode counts signal events applied to CHANNEL A INPUT, incrementing one count for each event. The display is updated continuously unless the HOLD button is pressed. The count resumes when the HOLD button is released. The Totalize mode can also be controlled remotely with the use of the external control input connector located on the rear panel.
 - **CHECK**—The Check mode uses the internal time base as a signal source to make a general check of the operating system. The display will indicate a frequency of 10 MHz.

- 15. LOW PASS FILTER Button.** Attenuates signals applied to CHANNEL A INPUT that are above 100 kHz, preventing high-frequency interference. Select this mode to measure signals below 100 kHz.
- 16. INPUT VOLTAGE Button.** Allows you to select between two levels of input signals for the CHANNEL A INPUT. When pushed in, the maximum allowable peak-to-peak input level is from 3 V to 42 V (30 Vrms). When in the out position, the maximum allowable peak-to-peak input level is from 50 mV to 5 V.



CAUTION. To avoid the risk of fire or possible damage to the CMC251, be sure that the equipment generating the signal is properly grounded before you make any connections to the inputs.

- 17. CHANNEL A INPUT.** Use this connector to measure signals with a repetition rate from 1 Hz to 100 MHz.

Rear Panel

In addition to the line voltage selectors, power input, and fuse, there is a BNC connector for an external control input located on the rear panel



CAUTION. To avoid the risk of fire or possible damage to the CMC251, be sure the input equipment is properly grounded before making any connections. The external input connector is grounded to the power source ground.

The external control input (see Figure 3, item 1) provides remote control of two instrument functions: TOTAL and PULSE modes.

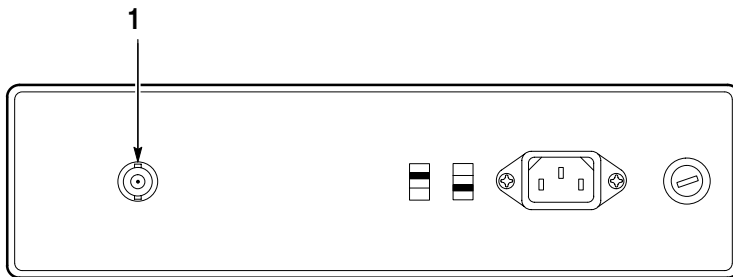

Figure 3: Rear Panel Signal Connections

In Total mode, the TTL logic levels start (TTL high) and stop (TTL low) the display updates. This performs the same function as the HOLD button.

In Pulse mode, the TTL logic levels select either negative (TTL low) or positive (TTL high) pulse width measurement.

Getting Started

Reference

This section describes typical setups of the CMC251 Frequency Counter for each of its measurement modes.

Making Frequency Measurements

Measuring frequencies with the CMC251 Frequency Counter is simple, although there are some items you need to consider before applying the signal to the inputs of the frequency counter.

1. Estimate the frequency of the signal source and determine the voltage level.

This enables you to use the appropriate input channel of the frequency counter. A good practice is to display the signal on an oscilloscope and obtain the peak voltage level. Refer to Table 1 and pick the appropriate input channel.

Table 1: A or B Channel Input

Estimated Frequency	Input Voltage	Proper Input Channel
1 Hz to 100 MHz	Less than 42 V peak	CHANNEL A INPUT
80 MHz to 1.3 GHz	Less than 1 V _{RMS}	CHANNEL B INPUT

2. Prepare to make a measurement, using the steps under one these sections: *Frequencies Below 10 MHz*, *Frequencies Below 100 MHz*, or *Frequencies Between 80 MHz and 1.3 GHz*.

Frequencies Below 10 MHz

1. Press the **FUNC** button until **FREQ A** is indicated with a lighted LED.
2. Refer to Table 2 and set the frequency counter front-panel buttons to obtain the best measurement for frequencies below 10 MHz.

Table 2: Selecting Features For Channel A (1 Hz to 10 MHz)

	50 mV to 5 V	3 V to 42 V
INPUT VOLTAGE	LO (button out)	HI (button in)
LOW PASS FILTER	ON (button in)	ON (button in)
PRESCALE	Button Out	Button Out

3. Connect the signal to the **CHANNEL A INPUT** connector.
4. Press the **GATE** button to select the desired display resolution.
See Tables 4 and 5 for resolution-versus-gate settings.

Frequencies Below 100 MHz

1. Press the **FUNC** button until **FREQ A** is indicated with a lighted LED.
2. Refer to Table 3 and set the frequency counter front-panel buttons to obtain the best measurement for frequencies between 10 MHz and 100 MHz.

Table 3: Selecting Features For Channel A (10 MHz to 100 MHz)

	50 mV to 5 V	3 V to 42 V
INPUT VOLTAGE	LO (button out)	HI (button in)
LOW PASS FILTER	OFF (button out)	OFF (button out)
PRESCALE	Button In	Button In

3. Connect the signal to the **CHANNEL A INPUT** input connector.
4. Press the **GATE** button to select the desired display resolution.
See Tables 4 and 5 for resolution versus gate settings.

Frequencies Between 80 MHz and 1.3 GHz

1. Press the **FUNC** button until **FREQ B** is indicated by a lighted LED.
2. After determining that the signal voltage level is 1 V rms or less, connect the signal to the **CHANNEL B INPUT** connector.
3. Press the **GATE** button to select the desired display resolution. Refer to Tables 4 and 5 for resolution-versus-gate settings.

Table 4: Gate Time Versus Resolution for Channel A

GATE Setting	Gate Time	Resolution	
		PRESCALE Off	PRESCALE On
X1	0.01 seconds	100 Hz	1 kHz
X10	0.1 seconds	10 Hz	100 Hz
X100	1 second	1 Hz	10 Hz
X1000	10 seconds	0.1 Hz	1 Hz

Table 5: Gate Time Versus Resolution for Channel B

GATE Setting	Gate Time	Resolution
X1	0.016 seconds	10 kHz
X10	0.16 seconds	1 kHz
X100	1.6 seconds	100 Hz
X1000	16 seconds	10 Hz

Making Period Measurements

A Period measurement is the time in seconds for a signal to complete one entire cycle. This measurement is taken by averaging the signal events for a certain number of internal clock pulses. Therefore, the gate setting determines the resolution (or accuracy) of the reading.

To make a period measurement, perform the following steps:

1. Estimate the signal source frequency and determine the voltage level. A good practice is to display the signal on an oscilloscope and obtain the peak voltage level.
2. Refer to Table 6 and set the frequency counter front-panel buttons to obtain the best period measurements.

Table 6: Period Measurements

	>40 ns (<25 MHz)		>400 ns (<2.5 MHz)	
	50 mV to 5 V	3 V to 42 V	50 mV to 5 V	3 V to 42 V
INPUT VOLTAGE	LO (button out)	HI (button in)	LO (button out)	HI (button in)
PRE-SCALE	Button In	Button In	Button Out	Button Out

3. Press the **FUNC** button until **PERIOD A** is indicated with a lighted LED.
4. Connect the signal to the **CHANNEL A INPUT** connector.
5. Press the **GATE** button to select the desired display resolution. Refer to Table 7 for the available resolutions.

Table 7: Resolution For Period Measurements

GATE Setting	Number of Events averaged	
	PRESCALE In	PRESCALE Out
X1	10 cycles	1 cycle
X10	100 cycles	10 cycles
X100	1000 cycles	100 cycles
X1000	10000 cycles	1000 cycles

Making Pulse-Width Measurements

A pulse-width measurement is the time in seconds from one edge of the signal to the next edge. This measurement is accomplished by averaging the signal events for a certain number of internal clock pulses determined by the gate setting. Therefore, the gate setting determines the resolution (or accuracy) of the reading.

The CMC251 Frequency Counter normally measures the positive pulse width, but it can measure the negative pulse width using the external input connector on the rear panel. This method is discussed in *Remote Control of Pulse-Width Measurements* on page 14.

1. Determine the signal voltage level. A good practice is to display the signal on an oscilloscope and obtain the peak voltage level.
2. Refer to Table 8 and set the frequency counter front-panel buttons to obtain the best pulse measurements.

Table 8: Pulse Width Measurements

	50 mV to 5 V	3 V to 42 V
INPUT VOLTAGE	LO (button out)	HI (button in)
LOW PASS FILTER	OFF (button out)	OFF (button out)
PRESCALE	No Effect	No Effect

3. Press the **FUNC** button until **PULSE A** is indicated by a lighted LED.
4. Connect the signal to the **CHANNEL A INPUT** connector.
5. Press the **GATE** button to select the desired display resolution. See Table 9 for the available resolutions.

Table 9: Resolution for Pulse Measurements

GATE Setting	Number of Events Averaged
X1	1 cycle
X10	10 cycles
X100	100 cycles
X1000	1000 cycles

Remote Control of Pulse-Width Measurements

The frequency counter normally measures the positive pulse width of the applied signal. The negative pulse width can be measured with the use of the external input connector on the rear panel. Refer to Figure 4 for a setup diagram.

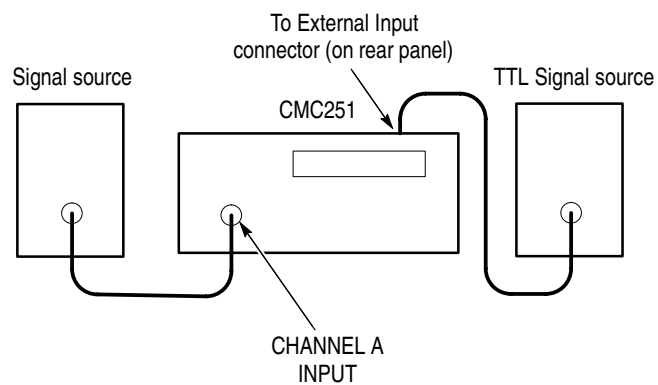
**Figure 4: Setup for Remote Control of Pulse-Width Measurements**

1. Perform steps 1 through 5 of *Making Pulse-Width Measurements* on page 13.



CAUTION. To avoid damage to the CMC251 Frequency Counter, ensure that the maximum voltage into the rear panel external input is no more than +5 V (TTL logic level).

2. Connect a TTL logic low level (0 volts) to the external input connector.

NOTE. Shorting the external input connector to ground accomplishes the same task as applying a TTL logic low.

3. The display reading indicates the negative pulse width. Changing the TTL logic level to high (+5 V) enables the frequency counter to measure the positive pulse width.

Counting Events

The CMC251 Frequency Counter can be used to count signal events. This feature can be controlled remotely with the use of TTL logic levels applied to the external input connector located on the rear panel. Refer to *Remote Control of TOTAL Mode* on page 16 for a description of its use.

1. Determine the signal voltage level. A good practice is to display the signal on an oscilloscope and obtain the peak voltage level.
2. Set the Channel A **INPUT VOLTAGE** switch as necessary, determined by the voltage reading obtained in Step 1.
3. Press the **FUNC** button until **TOTAL** is indicated by a lighted LED.
4. Connect the signal to the **CHANNEL A INPUT** connector.

The frequency counter will start counting events immediately and continue until the signal is disconnected.

Pressing the **HOLD** button freezes the display, but the count continues internally. The display will update when the **HOLD** button is toggled out and the count resumes.

Pressing the **RESET** button clears the display and resets the count back to zero. The count resumes when the **RESET** button is released.

Remote Control of TOTAL Mode

Refer to Figure 5 for the setup diagram for remotely controlling the TOTAL mode.

1. Perform Steps 1 through 4 of *Counting Events* on page 15.
2. Connect a signal source that can apply TTL logic levels of low and high (0 V and +5 V) to the external input connector.



CAUTION. To avoid damage to the CMC251 Frequency Counter, ensure that the maximum voltage into the rear panel input is no more than +5 V (TTL logic level).

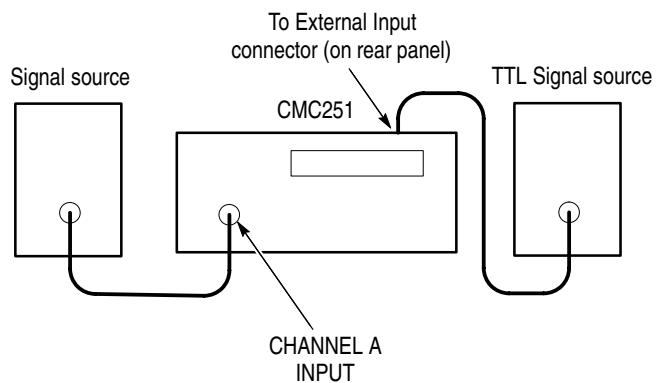

Figure 5: Setup for Remote Control of TOTAL modes

3. Control the TOTAL mode by applying a TTL logic signal to the external input connector as follows:
 - Apply a low level (0 volts) to stop the count (same as the HOLD button)
 - Apply a TTL logic high level (+5 V) to resume the count (same as releasing the HOLD button)

Checking Instrument Operation

At any time, you can verify the accuracy of the CMC251 Frequency Counter by using the CHECK function. Press the **FUNC** button until **CHECK** is indicated by the lighted LED. The readout will display 10.000 MHz.

Reference

Appendix A: Specifications

Table 10 and 11 list the characteristics of the CMC251 Frequency Counter that are guaranteed by the warranty.

Table 10: Warranted Characteristics

Characteristic	Measurement
Channel A Input	
Bandwidth	1 Hz to 100 MHz, AC coupled
Sensitivity (Sine wave terminated into 1 M Ω)	
20 mV _{RMS}	1 Hz to 30 MHz
50 mV _{RMS}	30 MHz to 100 MHz
Impedance	1 M Ω paralleled by 40 pF
Attenuation	3 V to 42 V (HI) 50 mV to 5 V (LO)
Maximum Input Voltage	42 V peak
Filter	-3 dB at 100 kHz

Table 10: Warranted Characteristics (Cont.)

Characteristic	Measurement
Channel B Input	
Bandwidth	80 MHz to 1.3 GHz, AC coupled
Sensitivity (Sine wave terminated into 50 Ω)	
5 mV _{RMS}	80 MHz to 600 MHz
15 mV _{RMS}	600 MHz to 900 MHz
35 mV _{RMS}	900 MHz to 1.3 GHz
Impedance	50 Ω
Maximum Input Voltage	1 V _{rms}
Internal Time Base	
Crystal Frequency	10 MHz (TCXO)
Setability	± 0.1 ppm (± 1 Hz)
Temperature Stability	<0.0001% (1 ppm from 0°C to 40°C)
Line Voltage Stability	< ± 0.4 ppm with 10% line voltage variation
Aging Rate	< ± 1 ppm/yr
Display	
Display Update Time	
Frequency Mode	Channel A: Selected GATE time plus 200 ms interval Channel B: Selected GATE time plus 640 ms interval
Period Mode	Selected cycles averaging plus 200 ms interval
Pulse Mode	Selected cycles averaging plus 200 ms interval
Totalize Mode	Continuous

Table 10: Warranted Characteristics (Cont.)

Characteristic	Measurement	
Frequency Mode		
Measurement specifications for frequency mode are applicable for a sine wave applied to the inputs.		
Channel A Range	<u>Prescale In</u>	<u>Prescale Out</u>
	10 MHz to 100 MHz	1 Hz to 10 MHz
Channel B Range	80 MHz to 1.3 GHz	
Accuracy	$\pm(1 \text{ count} + \text{time base error})$	
Channel A Resolution	<u>Prescale In</u>	<u>Prescale Out</u>
	1 Hz to 1 kHz	0.1 Hz to 100 Hz
Channel B Resolution	10 Hz to 10 kHz	
Period Mode		
Range	<u>Prescale In</u>	<u>Prescale Out</u>
	0.04 μs to 1.0 s	0.4 μs to 1.0 s
Frequency Range (Sine wave)	<u>Prescale In</u>	<u>Prescale Out</u>
	1 Hz to 25 MHz	1 Hz to 2.5 MHz
Accuracy	$\pm(1 \text{ count} + \text{time base error} + \text{trigger error})$	
Resolution	<u>Prescale In</u>	<u>Prescale Out</u>
	10 ps to 10 ns	100 ps to 100 ns
Pulse Mode		
Range	0.25 μs to 500 ms	
Frequency Range	1 Hz to 2 MHz	
Accuracy	$\pm(1 \text{ count} + \text{time-base error} + \text{trigger error} + 100 \text{ ns})$	
Resolution	100 ps to 100 ns, switchable in four decade steps	

Table 10: Warranted Characteristics (Cont.)

Characteristic	Measurement
Totalize Mode	
Range	0 to 99,999,999 counts plus overrange
Repetition Rate (Sine wave)	1 Hz to 10 MHz
Power	
Line Voltage Range	Selectable ranges at 50 Hz to 60 Hz 90 VAC to 110 VAC 108 VAC to 132 VAC 198 VAC to 242 VAC 216 VAC to 250 VAC
Environmental	
Operating Temperature	+10°C to +40°C, 75% relative humidity
Storage Temperature	-10°C to +60°C, 80% relative humidity

Table 11: Certifications and Compliances

<p>EC Declaration of Conformity – EMC</p>	<p>Meets intent of Directive 89/336/EEC for Electromagnetic Compatibility. Compliance was demonstrated to the following specifications as listed in the Official Journal of the European Communities:</p> <p>EN 55011 Class A Radiated and Conducted Emissions</p> <p>EN 50081-1 Emissions: EN 60555-2 AC Power Line Harmonic Emissions</p> <p>EN 50082-1 Immunity: IEC 801-2 Electrostatic Discharge Immunity IEC 801-3 RF Electromagnetic Field Immunity IEC 801-4 Electrical Fast Transient/Burst Immunity IEC 801-5 Power Line Surge Immunity</p>
<p>EC Declaration of Conformity – Low Voltage</p>	<p>Compliance was demonstrated to the following specification as listed in the Official Journal of the European Communities:</p> <p>Low Voltage Directive 73/23/EEC, amended by 93/68/EEC.</p> <p>HD401 S1 Safety Requirements for Electronic Measuring Aparatus.</p>

Table 12 lists the nonwarranted specifications of the CMC251 Frequency Counter.

Table 12: Typical Characteristics

Characteristic	Measurement
<p>Dimensions (H x W x D)</p>	<p>67 mm X 262 mm X 230 mm (2.6 in X 10.3 in X 9.0 in)</p>
<p>Power Consumption</p>	<p>22 VA, 12 W maximum</p>

Appendix A: Specifications

Appendix B: Maintenance

This appendix provides information for the basic maintenance of the CMC251 Frequency Counter.

Cleaning

To clean the frequency counter, use a soft cloth dampened in a solution of mild detergent and water. Do not spray cleaner directly onto the instrument, since it may leak into the cabinet and cause damage.

Do not use chemicals containing benzene, benzene, toluene, xylene, acetone, or similar solvents.

Do not use abrasive cleaners on any portion of the frequency counter.

Preparing for Shipment

If the original packaging is unfit for use or not available, use the following packaging guidelines:

1. Use a corrugated cardboard shipping carton having inside dimensions at least three inches greater than the instrument dimensions.
2. Put the instrument into a plastic bag or wrap to protect it from dampness and loose packing material.
3. Place the instrument into the box and firmly stabilize it with packing material.
4. Seal the carton with shipping tape.

Troubleshooting

Electronic maintenance on the CMC251 Frequency Counter must be performed by a trained technician. However, an operator can perform some basic and routine maintenance. The CMC251 Frequency Counter will give some indications of problems to aid the operator.



WARNING. *To prevent electrical shock, unplug the power cord and disconnect the signal input cable from any signal source before checking or replacing the fuse.*

No Display with Power On

If the digital display is not lighted, but the POWER button is pushed in and the CMC251 Frequency Counter power cord is plugged into an outlet, do the following steps:

1. Check the line fuse. If the fuse is open, replace it.
2. If the line fuse is good, check the power outlet for proper voltage. If the outlet voltage is incorrect, call service personnel.



WARNING. *To prevent electric shock, disconnect the power cord from the power source and the CMC251 Frequency Counter before checking continuity.*

3. If outlet voltage is correct, check power cord continuity. If the power cord fails the continuity check, replace the power cord.

Appendix C: Replaceable Parts

Replaceable parts may be ordered directly from your authorized Tektronix dealer.

Standard Accessories

The following items are shipped with the CMC251 Frequency Counter:

Table 13: Standard Accessories

Accessory	Tektronix Part Number
Fuse, 3AG, 0.3 A, 250 V, SB (90 – 132 V operation)	159-0029-00
User Manual	070-8527-XX
115 V Power Cord	Refer to Table 15

Optional Accessories

The following items are available as optional accessories:

Table 14: Optional Accessories

Accessory	Tektronix Part Number
Fuse, 3AG, .0125 A, 250 V, SB (198 – 250 V operation)	159-0313-00
230 V Power Cords	Refer to Table 15
36-inch, 50 Ω BNC cable	012-1341-XX
66-inch, 50 Ω coaxial cable signal adapter	103-0275-XX

Appendix C: Replaceable Parts

The following power cords are available.

Table 15: Accessory Power Cords

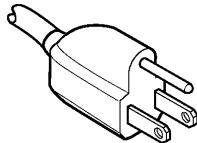
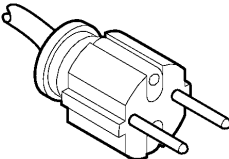
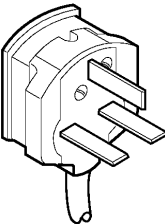
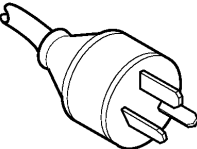
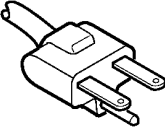
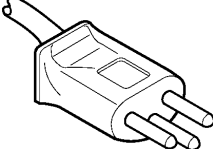
Plug Configuration	Normal Usage	Tektronix Part Number
	North America 115 V	161-0104-00
	Europe 230 V	161-0104-06
	United Kingdom 230 V	161-0104-07
	Australia 230 V	161-0104-05
	North America 230 V	161-0104-08
	Switzerland 230 V	161-0167-00