

## DC - 100 MHz PXI Differential Instrumentation Amplifier

- Differential 100 V Common Mode Input
- DC - 100 MHz Bandwidth
- AC/DC Coupling
- Programmable Attenuation/Gain/Offset
- 9 nV/ $\sqrt{\text{Hz}}$  Input Noise
- 50  $\Omega$  Output Impedance

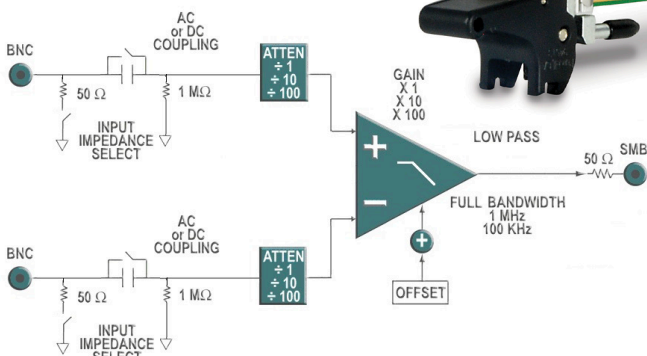

Figure 1.1 Block Diagram



The TEGAM Model 4040B expands the measurement range of your digitizer or analog inputs to real-world signals ranging from 100 V supply voltages to millivolt detector outputs. Elevated voltages and noisy environments present a barrier to making acceptable measurements with common digitizers that are limited by input impedance and voltage levels. Your investment in a high performance digitizer is significantly enhanced by having an instrumentation grade connection to the point of measurement.

The TEGAM Model 4040B includes six stages of signal-matching to ensure that you get the maximum use from your high-speed digitizer:

1. **Selectable input impedance** of 50  $\Omega$  or 1 M $\Omega$ , to match impedance with coaxial cables or oscilloscope probes.
2. **Selectable AC or DC coupling** allows processing of small AC signals with large DC offset.
3. **Selectable input attenuations** of  $\div 10$  and  $\div 100$  allows input levels as high as 100 V to be safely processed by the digitizer<sup>1</sup>.
4. Instrumentation amplifier **rejects common-mode voltages** and provides gain of X1, X10, and X100 for measuring small signals<sup>1</sup>.
5. **Programmable low-pass filters** assist with noisy signals or anti-alias at lower sampling rates.
6. **Programmable output offset** allows centering the output signal in the digitizer's span to maximize dynamic range.

Table 1.1 – Attenuation and Gain Combinations

Small Signal $V_{\text{peak}} \text{ Output} \leq 0.1 V_{\text{peak}}$								
Net Gain	Input Attenuation	Internal Amplifier Gain	Peak Input Voltage (V) Single Ended a,b.	Max Differential Voltage (V) w/o clipping a,b,c.	Max Volts to Chassis a,b,c.	Passband Flatness d,e.	Passband Bandwidth d.	3 dB Bandwidth d.
$\div 100$	$\div 100$	x1	< 100	< 100	100 V	$\pm 0.2$ dB	20 MHz	70 MHz
$\div 10$	$\div 10$	x1	< 10	< 10	40 V	$\pm 0.2$ dB	25 MHz	70 MHz
$\div 10$	$\div 100$	x10	< 10	< 10	100 V	$\pm 0.25$ dB	15 MHz	50 MHz
1	$\div 1$	x1	< 1	< 1	4 V	$\pm 0.15$ dB	20 MHz	100 MHz
1	$\div 10$	x10	< 1	< 1	40 V	$\pm 0.25$ dB	15 MHz	55 MHz
1	$\div 100$	x100	< 1	< 1	100 V	$\pm 0.25$ dB	15 MHz	50 MHz
10	$\div 1$	x10	< 0.1	< 0.1	4 V	$\pm 0.2$ dB	20 MHz	55 MHz
10	$\div 10$	x100	< 0.1	< 0.1	40 V	$\pm 0.25$ dB	15 MHz	55 MHz
100	$\div 1$	x100	< 0.01	< 0.01	4 V	$\pm 0.2$ dB	15 MHz	50 MHz
Large Signal $0.1 V_{\text{peak}} < V_{\text{peak}} \text{ Output} \leq 1 V_{\text{peak}}$								
$\div 100$	$\div 100$	x1	< 100	< 100	100 V	$\pm 0.2$ dB	10 MHz	30 MHz
$\div 10$	$\div 10$	x1	< 10	< 10	40 V	$\pm 0.2$ dB	10 MHz	30 MHz
$\div 10$	$\div 100$	x10	< 10	< 10	100 V	$\pm 0.25$ dB	10 MHz	30 MHz
1	$\div 1$	x1	< 1	< 1	4 V	$\pm 0.15$ dB	10 MHz	30 MHz
1	$\div 10$	x10	< 1	< 1	40 V	$\pm 0.25$ dB	10 MHz	30 MHz
1	$\div 100$	x100	< 1	< 1	100 V	$\pm 0.25$ dB	10 MHz	30 MHz
10	$\div 1$	x10	< 0.1	< 0.1	4 V	$\pm 0.2$ dB	15 MHz	35 MHz
10	$\div 10$	x100	< 0.1	< 0.1	40 V	$\pm 0.25$ dB	10 MHz	30 MHz
100	$\div 1$	x100	< 0.01	< 0.01	4 V	$\pm 0.2$ dB	15 MHz	35 MHz

a. 5 V<sub>rms</sub> max into Input Impedance 50  $\Omega$   
 b. DC + Peak AC not to exceed Peak Input Voltage in Table  
 c. System offset adjusted to zero volts  
 d. Conditions: Input Impedance 50  $\Omega$ , Output Load 50  $\Omega$ , DC Coupling, System offset adjusted to zero volts  
 e. Allowance from Nominal Gain

<sup>1</sup>See Table 1.1 for specific combinations and settings.

### Software

The TEGAM Model 4040B comes complete with VISA-compliant drivers for LabVIEW, Microsoft C++, and Visual Basic. In addition, an interactive front panel application provides manual control of all of the board's features.



General Specifications	Value	Clarification
Channels	Single Channel	Differential Input
Net Gains	100, 10, 1, 0.1, 0.01	Selectable, Output Load 50 Ω
Attenuations	100, 10, 1	Selectable, Output Load 50 Ω Independent of Gain Setting
Gains	100, 10, 1	Selectable, Output Load 50 Ω Independent of Attenuation Setting
Common Mode Rejection Ratio (CMRR)	≥77 dB at 60 Hz, ≥ 50 dB at 1 MHz	All Net Gain Ranges
Total Harmonic Distortion	≤-60 dB @ 1 MHz	Output Load 50 Ω, Output Voltage 1 V <sub>p-p</sub> Input Impedance 1 MΩ, Attenuation 1, Gain 1
Noise	9 nV / √Hz 99 nV / √Hz 990 nV / √Hz	Gain 1, 10, or 100, Frequencies >100 Hz Attenuation 10, Frequencies >100 Hz Attenuation 100, Frequencies >100 Hz
Over-voltage Protection (In Any Range)	±100 V	DC + Peak AC, Input Impedance 1 MΩ
Coupling	AC, DC	Selectable, AC ≥10 Hz
Low Pass Filter, Cutoff Frequency	100 kHz, 1 MHz	Selectable, Single Pole Filter
Input Connection Type	BNC Jacks	50 Ω, Quantity 2
Input Impedance	1 MΩ     20 pF, 50 Ω <sup>1</sup>	±1%, Selectable
Peak Input Voltage (Basic)	≤100 V (DC + Peak AC)	See Table 1.1
DC Gain Accuracy	±[(0.1%  input  x Net Gain)+ 100 μV] ±[(0.1%  input  x Net Gain)+ 300 μV] ±[(0.2%  input  x Net Gain)+ 100 μV] ±[(0.2%  input  x Net Gain)+ 300 μV]	Attenuation 1, Gain 1, or 10 <sup>2</sup> Attenuation 10 or 100, Gain 1 <sup>2</sup> Attenuation 1, Gain 100 <sup>2</sup> Attenuation 10 or 100, Gain 10 <sup>2</sup> Attenuation 10 or 100, Gain 100 <sup>2</sup>
Gain Temperature Stability	± 0.01% of reading / °C	All Net Gain Ranges
Passband Flatness (Basic)	± 0.15 dB	See Table 1.1
Passband Flatness Bandwidth (Basic)	25 MHz	See Table 1.1
3 dB Bandwidth (Basic)	100 MHz	See Table 1.1
Output Connection Type	SMB Jack (Male)	50 Ω
Output Impedance	50 Ω	±1%
Maximum Output Voltage	±1 V	Single Ended, Output Load 50 Ω
Output Rise Time	≤ 3.5 ns	Change from 0.1 V to 0.9 V on the output, with a 0 to 0.1 V step of input, Attenuation 1, Gain 10
Offset Range	-1.2 V to +1.2 V	Minimum offset range, Output Load 50 Ω
Offset Resolution	38 μV per step	Typical, 16 bit monotonic DAC, Output Load 50 Ω
Offset Temperature Stability	± 40 μV / °C	Typical, Output Load 50 Ω
Interface	PXI / cPCI	
<sup>1</sup> 5 V <sub>rms</sub> max into 50 Ω <sup>2</sup> System Offset adjusted to zero volts		
Environmental Specifications	Value	
Operating Temperature	0 °C to +45 °C, (32 °F to 113 °F) Ambient	
Storage Temperature	-20 °C to +50 °C, (-4 °F to +122 °F)	
Humidity Range	< 80 % RH Non-Condensing	
Warm-Up Time	30 minutes	

ACCESSORIES	DESCRIPTION	PART NUMBER
<b>Included Accessories</b>	CD Manual	4040B-840
<b>Optional Accessories</b>	1 ft SMB Female to SMB Female Cable	CA-3-12
	1 ft BNC Male to SMB Female Cable	CA-4-12
	3 ft BNC Male to SMB Female Cable	CA-4-36
	3 ft BNC Cable for General Purpose I/O Connections	CBL-3102
	50 ohm BNC (F-M-F) Tee adapter	BNC-3285

**Graph 1.1 – 4040B Frequency Response, Attenuation 100, Gain 1**

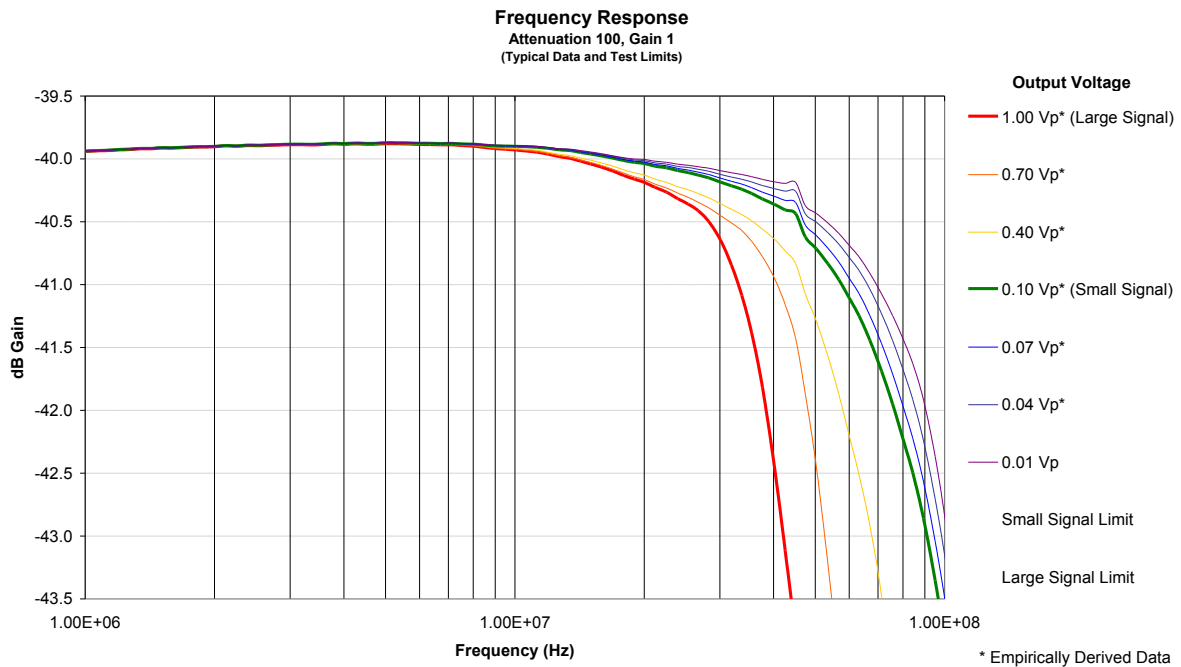

**Graph 1.2 – 4040B Frequency Response, Attenuation 10, Gain 1**

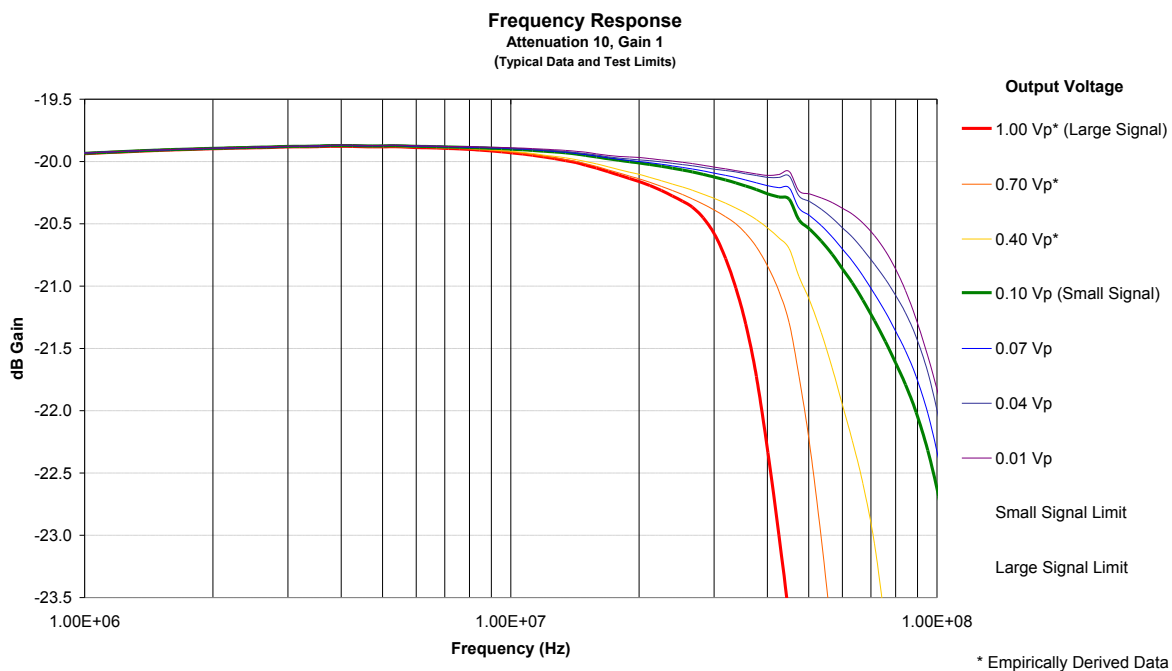

**Graph 1.3 – 4040B Frequency Response, Attenuation 1, Gain 1**

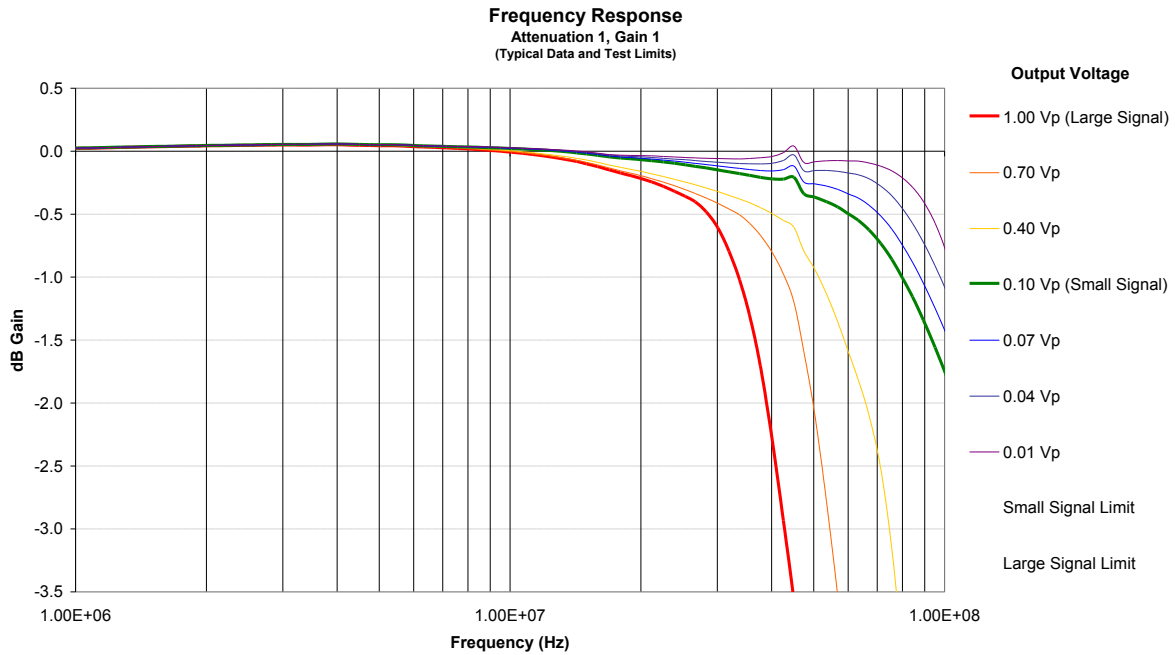

**Graph 1.4 – 4040B Frequency Response, Attenuation 1, Gain 10**

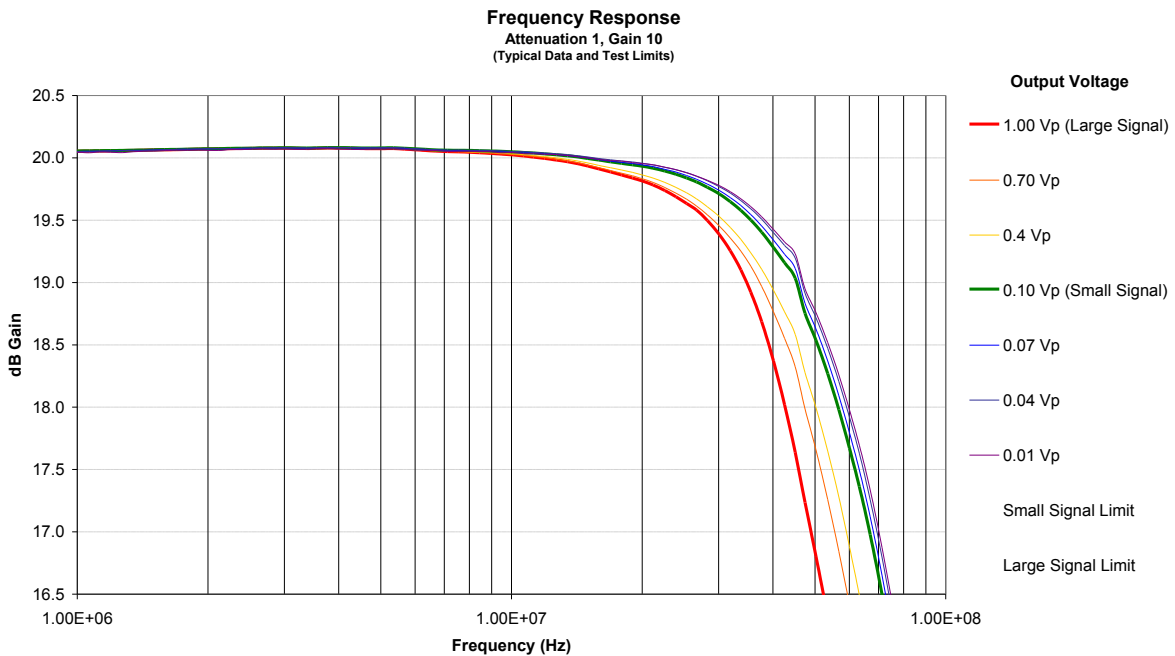

**Graph 1.5 – 4040B Frequency Response, Attenuation 1, Gain 100**

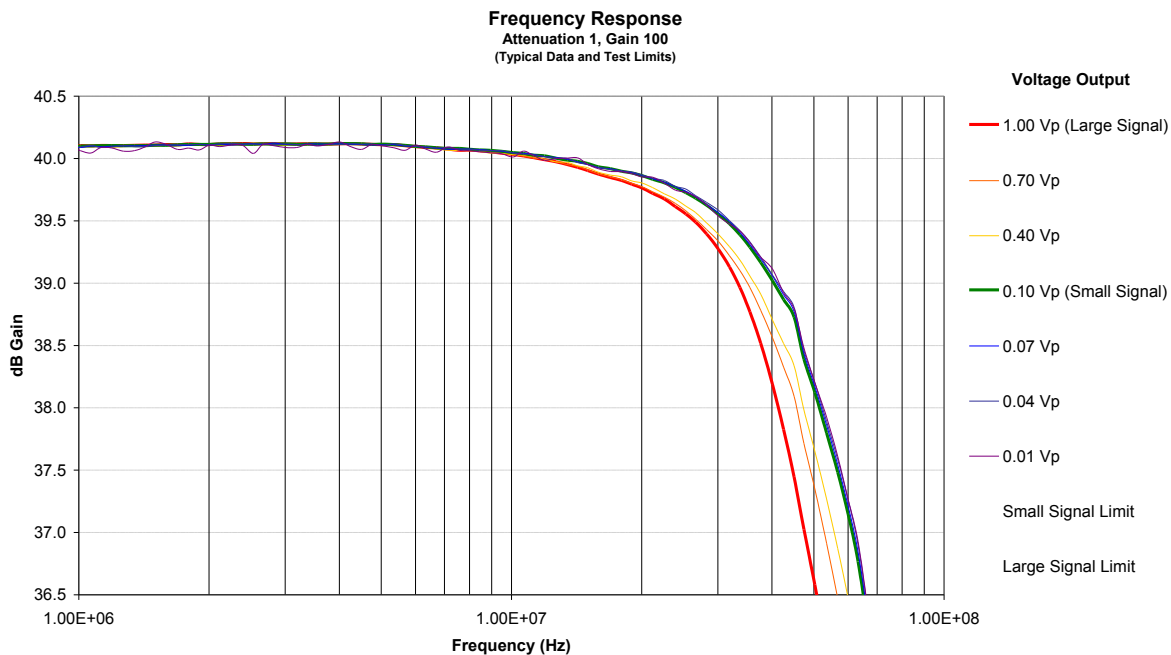

**Graph 1.6 – 4040B Frequency Response, Attenuation 100, Gain 10**

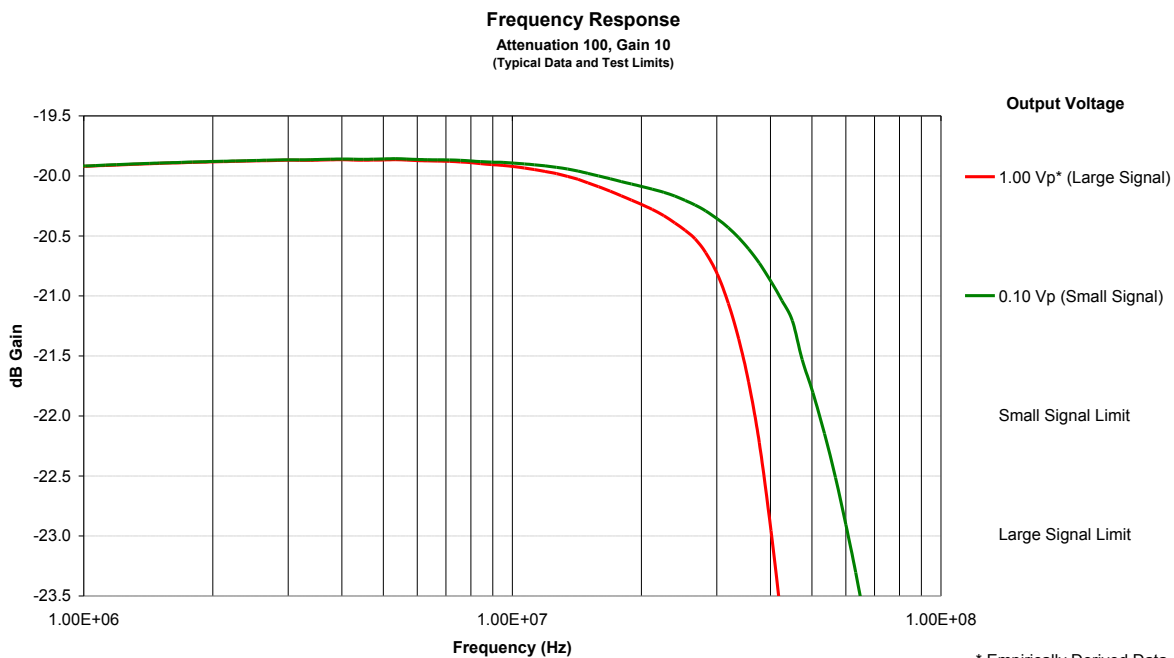

\* Empirically Derived Data

**Graph 1.7 – 4040B Frequency Response, Attenuation 100, Gain 100**

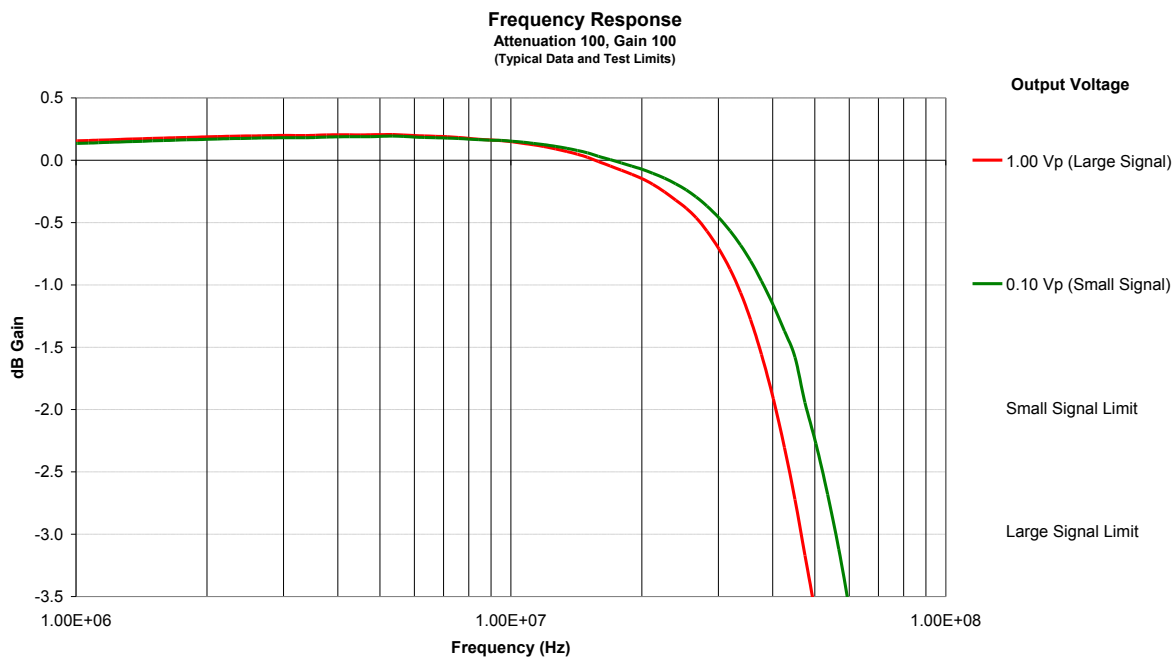

**Graph 1.8 – 4040B Frequency Response, Attenuation 10, Gain 10**

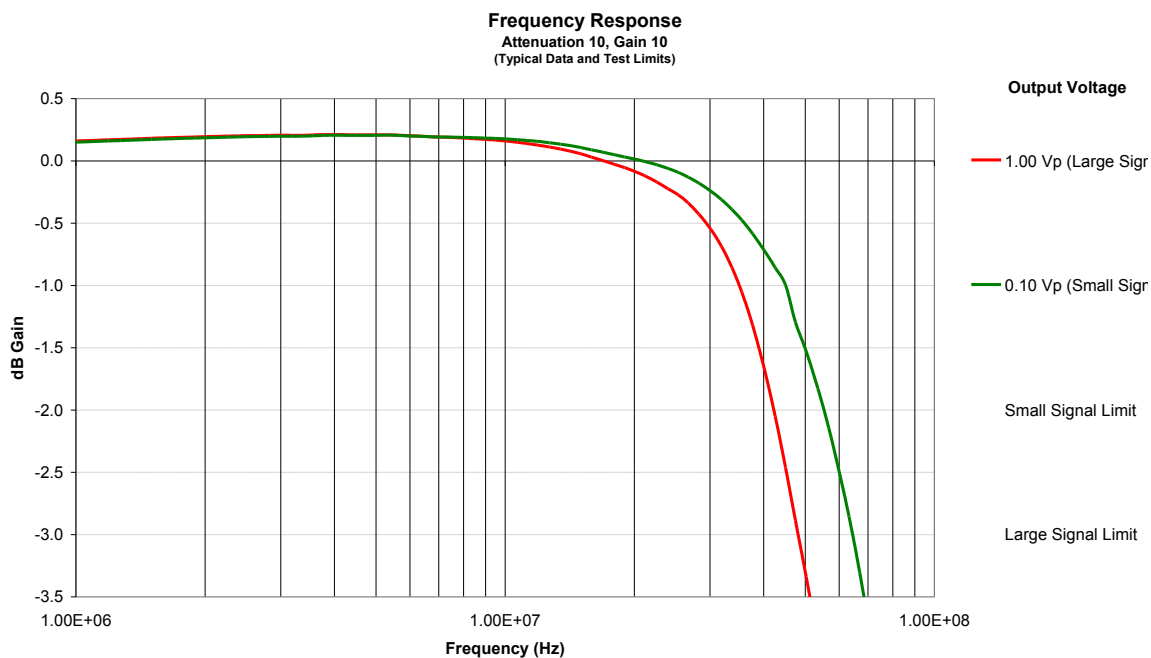

Graph 1.9 – 4040B Frequency Response, Attenuation 10, Gain 100

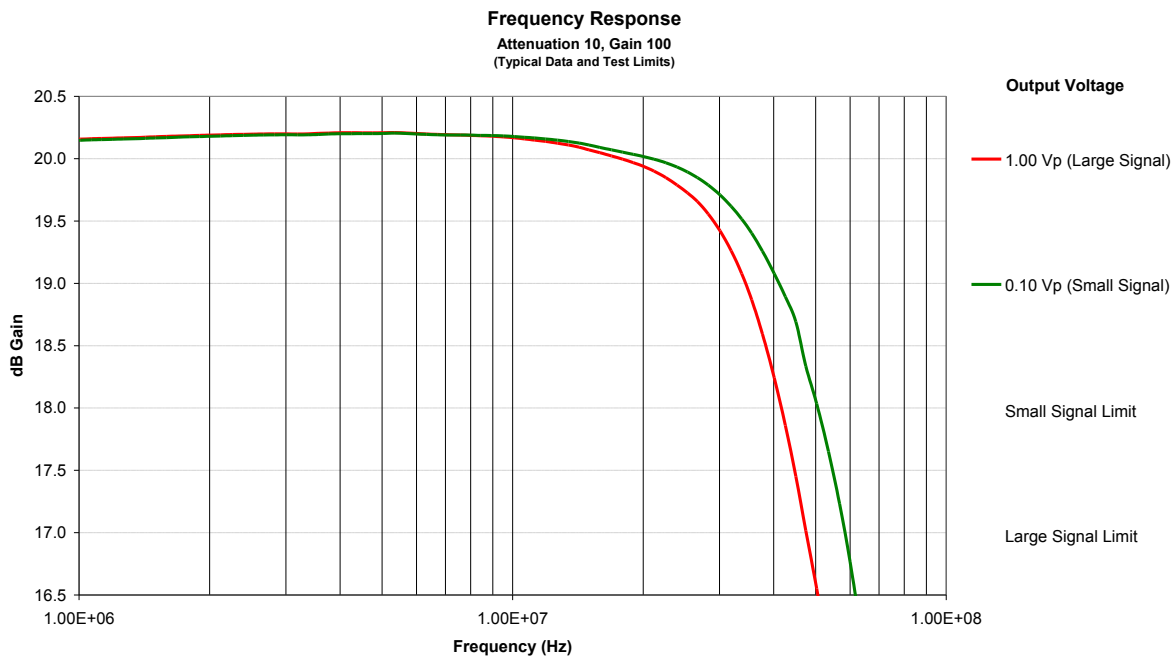

## APPLICATION EXAMPLES

1. Switch mode power supply circuit measurement when the measurement points (A and B below) are not referenced to ground.

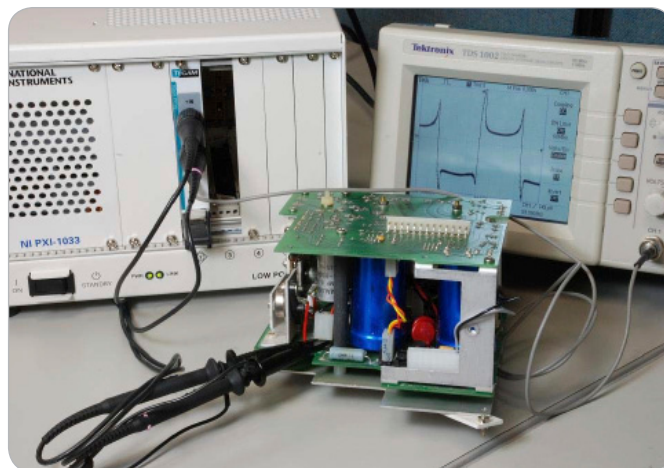
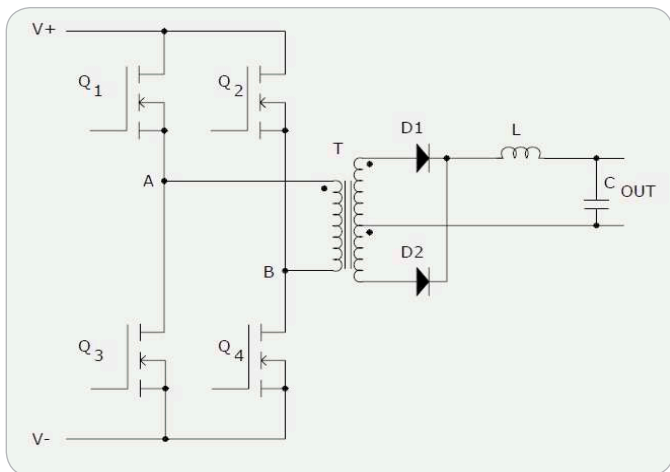

2. Extract a small (mV) signal riding on top of a large signal.

