

TPIP 550B
Manual Issue # 15A
Firmware Rev. 2.14N

**TELE-PATH INSTRUMENTS
ISDN PORTABLE TEST SET
MODEL 550B
OPERATING MANUAL**

TELE-PATH INSTRUMENTS
221 S. YORKSHIRE ST., SALEM, VA 24153
(540) 375-0500
© 1995



Manufactured under an NSAI Registered
ISO 9001 Quality System



TABLE OF CONTENTS

CONTENTS	PAGE
SECTION I - INTRODUCTION	
1.1 GENERAL INFORMATION	1- 1
1.1.1 BASIC RATE ISDN	1- 2
1.2 PHYSICAL DESCRIPTION	1- 8
1.2.1 EXTERNAL CONNECTIONS	1- 9
1.2.2 CONTROLS AND INDICATORS	1-10
SPEAKER	1-11
LINE INTERFACE AREA	1-11
STATUS LED's	1-13
S/T INTERFACE AREA	1-15
POWER	1-19
HAND SET JACK	1-19
DATA ACCESS	1-21
OFF HOOK LED	1-21
1.2.3 MENUS AND KEYPAD	1-22
SETUP	1-24
REDIAL	1-29
SPEED DIAL	1-30
SPID	1-31
STATUS REPORTING	1-32
STATES	1-33
CAUSE	1-40
RESULT	1-45
AUTO CONFIGURATION	1-46
BERT KEY	1-47
BERT TESTING	1-49

Table of Contents

STORE NUMBERS	1-52
UTILITY FUNCTIONS	1-53
MODES	1-53
DUAL CALL	1-59
CONFIG	1-62
DATA	1-68
VOICE CALLS	1-75
DATA CALLS	1-81
D-PACKET CALLS	1-85
1.2.4 CABLES AND ACCESSORIES	1-88
1.3 MAINTENANCE	1-90
1.3.1 CALIBRATION	1-90
1.3.2 EPROM MODULE	1-90
1.4 SPECIFICATIONS	1-92
SECTION II - OPERATION	
2.1 POWER UP	2- 1
2.2 SETUP	2- 3
2.3 PRE-QUALIFICATION	2- 8
2.4 TESTING AT "U" INTERFACE	2-11
2.5 TESTING AT "S/T" INTERFACE	2-12
2.6 DUAL CALL CAPABILITY	2-13
2.7 P-PHONE TESTING	2-15
2.8 POTS TESTING	2-26
2.9 NT1 REPLACEMENT	2-28
2.10 MONITOR D-CHANNEL	2-29
2.11 ONE PERSON ISDN BRI TURN-UP	2-32

Table of Contents

APPENDIX A - QUICK REFERENCE	A- 1
HOW TO MAKE A CALL	A- 1
VOICE CALL	A- 1
DATA CALL	A- 3
DUAL B-CHANNEL CALL	A- 5
D-PACKET DATA CALL	A- 7
ONE PERSON ISDN BRI TURN-UP	A- 9
VOICE TURN-UP	A- 9
CIRCUIT SWITCHED TURN-UP	A- 9
DATA TURN-UP	A-10
2B1Q EOC MESSAGES	A-11
2B1Q LAYER 1 MESSAGES	A-11
AT&T N-CHANNEL MESSAGES	A-11
LAYER 2 MESSAGES	A-12
LAYER 3 MESSAGES	A-12
CAUSE MESSAGES	A-14
APPENDIX B - GLOSSARY	B- 1
INDEX	i



SECTION I
INTRODUCTION

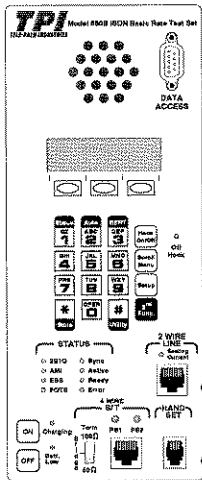
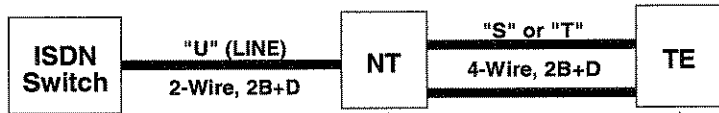

**TPI Model 550B
ISDN
Portable Test Set**

1.1 GENERAL INFORMATION

The Tele-Path Model 550B ISDN Portable Test Set is a compact, battery operated device used to conduct testing of ISDN circuits at the customer premise, the input and output of the ISDN repeater housing, or at the main distribution frame. The Model 550B is designed both for rugged durability and ease of use, with menu driven screens.

The Model 550B's operating modes allow it to function as an NT1 (Network Termination), as TE (Terminal Equipment), as both (NT1/TE), or as LT (Line Termination). It may be connected to either the DSL (Digital Subscriber Loop) U interface, or the S/T interface. It is compatible with AT&T AMI, and 2B1Q DSL interfaces, and EBS (P-Phone) and POTS Line Interfaces. The Model 550B allows placement of additional loss on the circuit, either at the "LINE" U Interface or the "S/T" interface for margin analysis testing.

The Model 550B ISDN Portable Test Set allows you to select a loopback for either of the B channels, or for the full bandwidth (2B+D). The Model 550B also responds to network controlled loopbacks at the NT1.

ISDN testing and measurements made by the Model 550B include:

- FEBE (Far End Block Errors) and FEBE Errored Seconds in all ISDN "U" interface modes,
- CRC Errors and CRC Errored Seconds with 2B1Q Interface selected,
- AMI Frame Errors and Frame Errored Seconds with AT&T AMI interface selected,
- S/T FRAME Errors and Errored Seconds, and Bipolar Violations (BPV's) and Errored Seconds on the S/T Interface in NT1 and TE modes,
- Bearer Service selections:
 - Circuit-Switched Voice/Data and
 - Packet Data,
- Dual Call Testing,
- Bit Error Testing,
- D-Channel message analysis,
- Cause Messages,
- Layer 1, 2, 3 States,
- Optional Service Testing:
 - EBS (P-Phone) and
 - POTS,
- Pre-Qualification of Loop:
 - LT Emulation, generating Layer 1 2B1Q signal, and
 - Generation of 40KHz Test Tone

1.1.1 BASIC RATE ISDN

INTRODUCTION

ISDN today is a Digital Network which promises a wide range of enhanced services, including Voice, Data, and Image. While ISDN customers may subscribe to either the Primary Rate Interface (PRI) service, or the Basic Rate Interface (BRI) service, BRI has the most immediate application since it is designed to connect individual Terminal Equipment to the Integrated Services Digital Network (ISDN). Centrex services can be configured to provide voice and data service over the same 2-wire single subscriber loop. Telecommuting can be economically supported with the 2B+D format in the home. Business-to-business data communications applications can use 64 Kbps speeds, or even 128 Kbps using two B-Channels.

Introduction

ISDN BASIC RATE INTERFACE

ISDN divides a standard 2-wire non-loaded telephone line into three Digital Channels capable of simultaneous Voice, Data, and low speed Video transmission. The three Channels are comprised of two Bearer (B) Channels, which carry Voice, Circuit-Switched, or Packet-Switched Data up to 64 Kbps, and a 16 Kbps Data (D) Channel for Packet-Switched Data and Signalling information. When combined, the two B-Channels and one D-Channel make up the Basic Rate (2B+D) Access. A Maintenance Channel and Framing information are added, and the result is a transmission rate of 160 Kbps at the "U" Interface. See Figure 1 below:

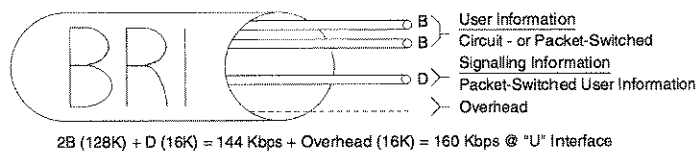

Figure 1. ISDN Basic Rate Interface

A typical configuration for ISDN Basic Rate Access is shown in Figure 2 below.

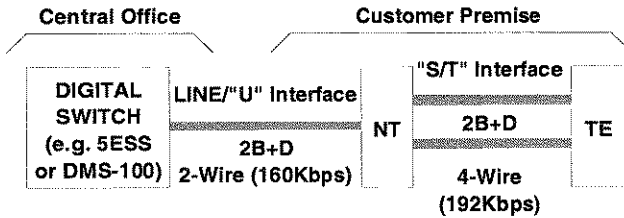
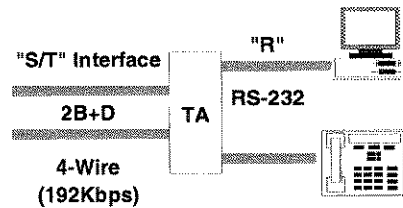

Figure 2.
ISDN
Basic Rate Access



LINE/"U" Interface

The "U" Interface refers to the physical interface on the Network side of an NT1. It is a 2-wire interface that uses an echo cancelling technique to transmit and receive information over the same pair of wires. A total data rate of 160 Kbps is used with a 144 Kbps payload.

Approximate Cable Length* for dB Loss on "U" Interface Pads		
	2B1Q	AMI
1 dB	367	308
2 dB	735	617
3 dB	1102	925
4 dB	1470	1234
5 dB	1838	1543
6 dB	2205	1851
7 dB	2573	2160
8 dB	2941	2469
9 dB	3308	2777
10 dB	3676	3086
11 dB	4404	3395
12 dB	4411	3703
13 dB	4779	4012
14 dB	5147	4320
15 dB	5514	4629

* 26 gauge cable

(NT) Network Termination

Network Termination (NT1) is the Customer Premises termination equipment that converts the 2-wire "U" Interface signal to a 4-wire "S/T" Interface signal. The NT1 also provides some simplified looping capabilities for testing of the facilities.

The term NT2 refers to a device that terminates a PRI ISDN 4-wire interface circuit.

S/T Interface

The S/T Interface is the standard ISDN Interface used by ISDN Terminals and is the physical interface on the Terminal side of an NT1. It is a 4-wire transmission interface, with one pair used to transmit and one pair used to receive, at a total rate of 192 Kbps with a payload of 144 Kbps.

Introduction

(TE) Terminal Equipment

Terminal Equipment is a Customer ISDN Terminal that operates when connected to an ISDN Basic Rate Access Interface, either a "U" or an "S/T". Examples are Digital Telephones, Data Terminals, and Integrated Work Stations.

Other kinds of Customer Terminals which operate from a non-ISDN Interface (RS-232), would need a Terminal Adapter (TA) to convert from the non-ISDN Interface to the S/T ISDN Interface.

2B1Q Line Code

The ANSI "U" Interface specification incorporates a 2B1Q Line Code, which is the electrical representation of digital signaling, and represents the pattern of pulses carried across the wire that forms the "1's" and "0's" transmitted. 2B1Q adds adaptive digital signal processing to this pattern of pulses, which can smooth out interference on a line to create the capability of using ordinary non-loaded twisted pair for distances of up to 18,000 feet using 26 ga. cable (- 42dB).

The major Switch vendors initially used their own proprietary Line Codes, e.g., AT&T AMI (Alternate Mark Inversion) and NTI AMI, but are now bringing 2B1Q to their products.

The 2B1Q (two Binary, one Quaternary) Line Coding is a four level, or quaternary code. Each level is determined from a single combination of two bits. Thus, 160 Kbps (binary) equates to 40 KHz. The lower frequency is desirable for extending the distance over which transmission is possible.

Introduction

1.2 PHYSICAL DESCRIPTION

The TPI Model 550B ISDN Portable Test Set illustrated below consists of circuit boards and a battery pack, housed in an aluminum case. It weighs 2½ pounds and has external dimensions of 9½" high, 4½" wide x 2" deep for the basic unit.

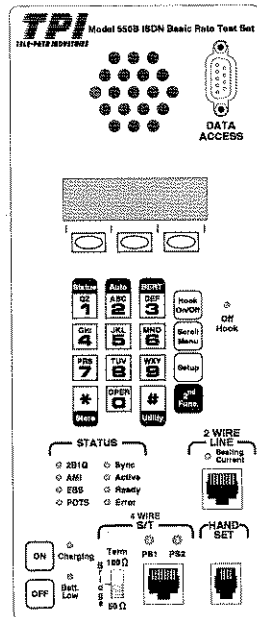

The internal battery pack is a custom NiCad rechargeable flat pack that can be externally charged via the TPI 550B-4 Battery Charger/AC Adapter. A fully charged battery will typically last for eight hours of 2B1Q Interface operation. When the "Batt. Low" LED illuminates, there are approximately 10 minutes of operating time left before complete shutdown. At that time, the internal battery needs to be recharged (TPI 550B-4). The recommended recharge time is 12 to 14 hours (overnight).

Introduction

An aluminum hinged cover is attached to the unit to protect the control panel when the unit is being transported. The cover is secured by a latch that snaps loose and unhooks.

A D-ring is attached to the top of the unit for convenience to allow attachment of the portable set to a line-up rack. (A clip hook is provided in the soft pack carry case.)

The hinged cover houses a lid Test Summary Label that outlines unit operation.

1.2.1 EXTERNAL CONNECTIONS

Connections to the DSL (**LINE**) U Interface and **S/T** Interface are made on the front panel. Connection of an external Hand Set, TPI 550B-8, may also be made via the front panel modular jack provided.

The right side of the case houses a connector for the TPI 550B-4 Battery Charger / AC Adapter. The top side of the unit has a D-ring for attachment to a line-up rack (A clip hook attachment is provided in the Soft Pack Carry Case for the Model 550B). The bottom side of the case houses a microphone grid for the hands-free mode of operation.

1.2.2 CONTROLS AND INDICATORS

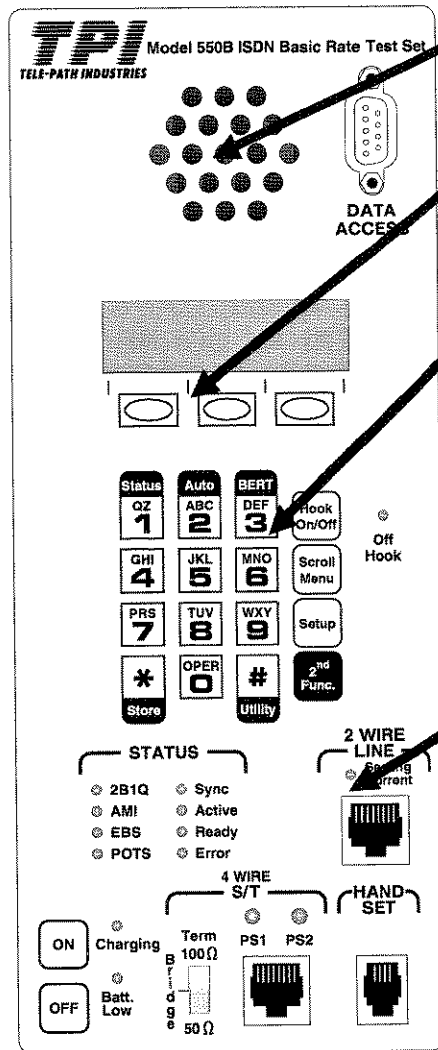

Introduction

Speaker

In the hands-free mode, the integral speaker produces an amplified version of received voice.

LCD DISPLAY AND KEYPAD

The LCD display, keypad, and soft keys are used to make menu selections that view the line status, auto evaluate the interface, conduct BERT testing, setup voice and data calls, select a specific call control type, backlight the display, select a B-Channel, set the TEI, adjust the volume level, enable the D-Channel monitor function, select the call appearance, adjust the LCD contrast, initiate Loopbacks, and store frequently used numbers.

2 WIRE LINE INTERFACE Area

This area of the front panel is used to make connection to the 2 wire Line Interface (U Interface) when the ISDN Portable Test Set is in the NT1 or NT1/TE mode. It is comprised of a sealing current indicator, and a modular 8 pin connector.

The "**Sealing Current**" LED will light green when at least 2 mA of sealing current is detected in either polarity, except in the AMI mode (will not illuminate if reversed).

The modular 8 pin connector is used to make connection to the line.

Introduction

Controls and Indicators

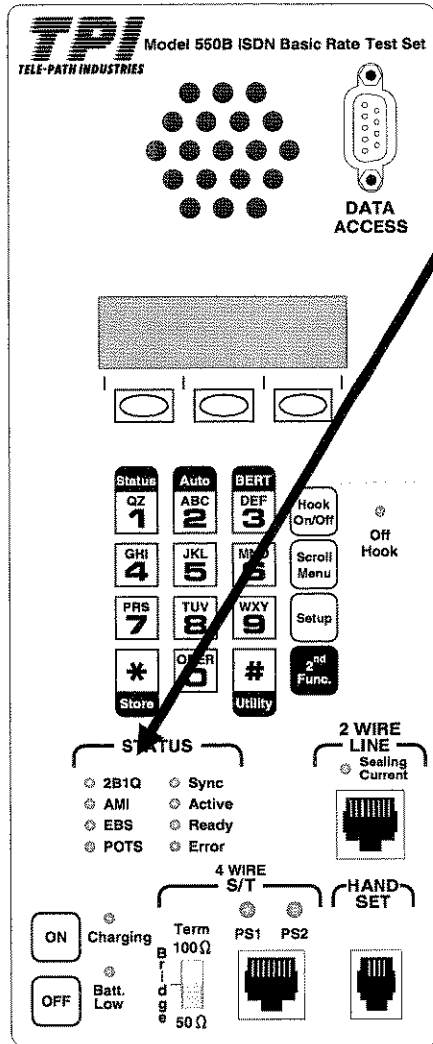

Introduction

STATUS LED's

The **STATUS** LED's indicate the active Line Interface. Please note that if an interface has not been installed on your Test Set, the LED for that interface will not light and that interface will not activate.

These LED's also indicate framing, activity, and errors detected on the line.

The "**Sync**" LED will light Green when the test set has been able to gain synchronization with the received BRI carrier signal.

The "**Active**" LED will light Green when Layer 1 communication has been established.

The "**Ready**" LED will light Green when the Layer 2 initialization process has been completed and indicates a call may be attempted from the test set.

The "**Error**" LED will light Red when an error has been detected. When lit (steady or pulsing), accessing the STATUS RESULTS menu will display what errors are occurring.

Introduction

Controls and Indicators

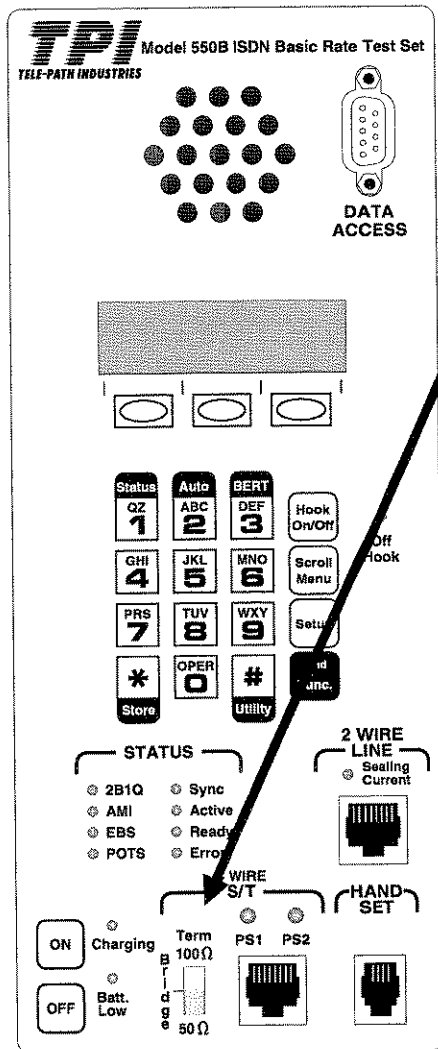

Introduction

4 WIRE S/T INTERFACE Area

This area of the front panel is used to configure and make connection to the 4 wire S or T Interface when the Model 550B is in the TE or NT1 mode. It is comprised of a termination switch, PS indicators, and a modular 8 pin connector.

The "**Term**" switch may be used to place either a 100 Ω or a 50 Ω termination on the S/T line, or in the "**Bridge**" position, there would be no termination.

The **PS** LED's show the status of Power Sources 1 & 2 (Refer to the Power Feeding diagram on the next page). These LED's will light green when their corresponding power sources have at least 30 Volts. They will light red if the polarity has been reversed on their corresponding power source.

The modular 8 pin connector is used to make connection to the S/T line.

Introduction

Controls and Indicators

NT			TE	
1		POWER SOURCE 3		1
2				2
3				3
6	RX	POWER SOURCE 1	TX	6
5				
4	TX		RX	4
7		POWER SOURCE 2		7
8				

Reference Configuration for Power Feeding

NOTE 1 *Access lead designations "1" through "8" correspond to contact assignments of the 8-pin network interface connector. Access lead pairs 4-5 and 3-6 are for bi-directional transmission of the Digital signal and may provide a phantom circuit for power transfer to a TE (Power Source 1). Access lead pair 7-8 may be used for additional power transfer to a TE (Power Source 2).*

- NOTE 2** *Power Source 1, the Sealing Current power, derives its power locally (commercial power and/or batteries). The source may be an integral part of the NT.*
- NOTE 3** *Power Source 2, the Stand Alone Power Pair, also derives its power locally (commercial power and/or batteries). The source may be located or associated with the NT or it may be located separately; eg, in a remote wiring closet.*
- NOTE 4** *Power Source 3 is an optional power source that may be used in some cases.*

Controls and Indicators

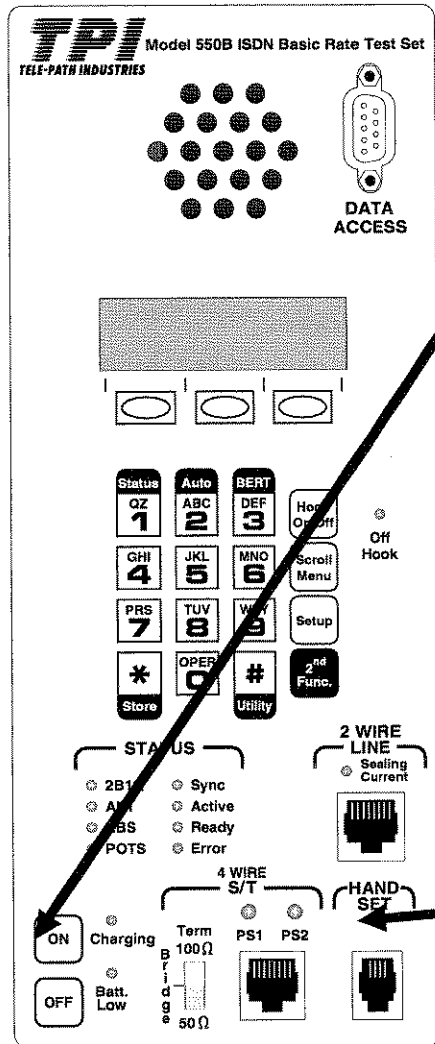

Introduction

POWER

The power switch is used to turn the ISDN Portable Test Set "ON" and "OFF". If there is no activity (DSL sync, S/T sync, or keystroke) for 5 minutes, the ISDN Portable Test Set will turn itself off to conserve battery life. If in POTS or EBS modes, the unit will turn itself off after 10 minutes.

NOTE: *The Automatic Power Down feature can be disabled via the "Utility/Config" menus.*

When the "Batt. Low" LED lights, there is approximately 10 minutes of operating time left before complete shutdown. However, if needed, the unit may still be used with the AC Adapter. This will give power to the unit and recharge the batteries, but at a slower rate than when the unit is not in operation.

CAUTION: *The 10 minute low battery warning is only approximate, and will depend on several factors. To insure proper operation throughout the testing procedures, we recommend that you recharge the battery as soon as the warning LED lights (recommended recharge time is 12 to 14 hours).*

HAND SET

An optional hand set, TPI 550B-8, may access either B channel. Connect the hand set to the 4-pin modular jack provided.

Controls and Indicators

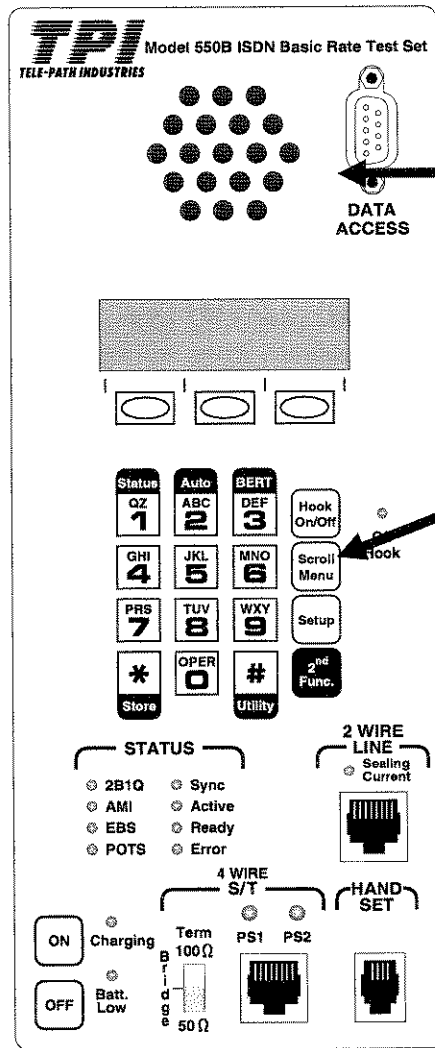

Introduction

DATA ACCESS

When the "Data Capability" option is purchased, the "**DATA ACCESS**" area of the front panel will be populated with a DB9/RS-232 connector for monitoring of "D" channel signalling. Information displayed will be formatted in English for easy analysis and raw HEX data is also shown.

The "Data Capability" option also allows the user to choose between placing a voice, circuit-switched data, or D-packet data call and allows selection of data call speed, and performing Bit Error Testing.

OFF HOOK

This LED, when illuminated, indicates that the Model 550B is in a call state.

1.2.3 MENUS AND KEYPAD

The LCD display, soft keys, and keypad are used to perform many functions from setting up voice and data calls to setting up and viewing test results.

Screen actions are initiated via the following keys:

- Soft keys - These three keys, located under the LCD display, perform different functions as described by the words above them in the LCD display.
- 1/Status - This key is used to review the ISDN line status, switch information, or test results.
- 2/Auto - This key automatically configures the Model 550B to the "U" Interface. (2B1Q & ATT AMI only)
- 3/BERT - This key allows the Model 550B to conduct 2047 Bit Error Testing on B1 or B2 Channels.
- */Store - This key is used to store up to ten numbers for repeat use.



- #/Utility - This key is used to select an EBS Station Address (in EBS mode only), for feature verification, to enable dual calls (and if enabled, select dual TEI), to select specific call control type, to select the "B" channel, to set the Call Appearance, to select the TEI mode (Auto/Fixed), to view the firmware rev. no. and installed options, to select the LCD screen Backlight, select 2B1Q mode (LT/NT1, and if LT, send EOC message), to view battery status, enable the auto power down feature, adjust the volume, adjust LCD contrast, enable B1, B2, or 2B+D Loopbacks, to insert loss, to generate a 2B1Q 40KHz test tone, to enable the RS-232 packet data monitor function (when optioned, and if enabled, select flow control), to select Bearer capability for switched voice or data (and if data, select speed) or packet data (if packet, select call user data, LCN, CUG, reverse charge, or RPOA).
- Hook On/Off - This key is used to set up/release a call, redial, speed dial, or enter the SPID.
- Scroll Menu - This key is used to scroll through sub menu selections of the selected menu.
- Setup - This key allows the user to review the current setup configuration and accept it, or respond to menu prompts to change the setup.
- 2nd Func. - This key is used to give other keys a 2nd function.

Introduction

Setup menu

When the unit is first turned on, it will conduct the Power On Self Test, and the following message will be momentarily displayed:

```
TPI 550B VERSION X.XX
SELF TEST
```

Upon successful completion of the Power On Self Test another message will be momentarily displayed, stating that the test has been passed.

The unit will then proceed to display the following configuration menu:

```
** PRESENT SETUP **
ISDN NT1TE 2B1Q 5ESS
PP
ACCEPT CHANGE
```

Please note that the contents of this screen will vary according to the unit's previous setup.

Press the appropriate soft key to either accept the setup shown, or enter a new setup.

Pressing the "CHANGE" soft key will result in the "Present Setup" screen:

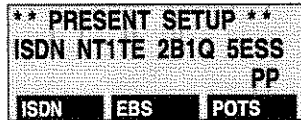

SERVICE MODE:

This menu is for selection of a service mode, which will include POTS and EBS (P-Phone) if optioned. After a service mode has been selected, or the "Scroll Menu" keypad button has been pressed, the following menu will result:

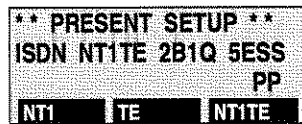

MODE OF OPERATION:

If you wish to use this unit connected in place of the NT1, select the "NT1" soft key. If you wish to use this unit connected in place of the TE, select the "TE" soft key. If you wish to use this unit connected in place of both the NT1 and the TE, select the "NT1TE" soft key.

If you wish to use this unit connected in place of the Line Terminating device, under the "Utility" menu, "CONFIG" sub-menu, select the "LTMODE" soft key.

The following menu will then appear:

```

** PRESENT SETUP **
ISDN NT1TE 2B1Q 5ESS
PP
2B1Q | AMI
  
```

INTERFACE:

NOTE: *The bottom line of this display will show your previous selection, and may not be as shown in this illustration.*

After an Interface has been selected, or the "Scroll Menu" keypad button has been pressed, the following menu will result:

```

** PRESENT SETUP **
ISDN NT1TE 2B1Q 5ESS
PP
5ESS | DMSF | NAT'L
  
```

CALL CONTROL:

Please select the current call control. The choices are: 5ESS, DMS-Functional, and optional National (Includes NI-1, NI-2, and NI-3 support).

Other menus will then proceed to ask for information relevant to your particular setup. The information needed to complete the setup will depend on what menu selections you have made up to this point. This may include the SPID, DN (Directory Number), TEI (Auto or Fixed), and whether the circuit is point-to-point or multi-point.

NOTE: *The TID is entered as part of the SPID.*

Introduction

For example, pressing 5ESS will display:

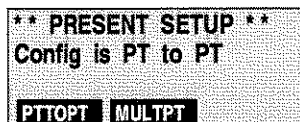

CONFIGURATION:

Selection of **MULTPT** will display:



Enter the new SPID (Service Profile Identifier) using the keypad keys. Pressing "**SEND**" will show the "Present Setup" display with "MP" for multi-point. (No SPID is required in a PT to PT circuit configuration for 5ESS custom.)

NOTE: *If a TID number is required, it should be entered as part of the SPID.*

If "National" Call Control or "DMS-Functional" has been selected, pressing "**Scroll Menu**" again will result in the following menu:

```

** PRESENT SETUP **
DIRECTORY NUMBER
DN :
NONE  BACKSP  ENTER
  
```

A directory number is required for non-CACH translations. The DN is normally seven digits and is automatically populated from the SPID, but may be changed via this menu.

Pressing "**Scroll Menu**" will move to the following TEI screen:

```

** PRESENT SETUP **
TEI IS AUTO 127
AUTO  FIXED
  
```

"**AUTO**" should be used unless emulating older CPE, in which case, a "**FIXED**" value (0-63) should be selected.

If, at any time, you wish to change the unit's setup, press the "**Setup**" keypad button. You will then return to this set of menus.

When you have entered all of the necessary information, the "ACCEPT / CHANGE" screen will again be shown.

```

IDLE
ON HOOK
REDIAL  SPEED  SPID
  
```

After accepting the new setup, you will proceed to the "ON HOOK" screen, which is the default screen:

From this screen, you can also access Last Number Redialing, Speed Dialing, and entry of the SPID.

NOTE: *The "On Hook" screen will display the calling number of an incoming call.*

REDIAL Soft Key

Pressing the "REDIAL" soft key will cause the last number dialed to be redialed. The following screen will appear:

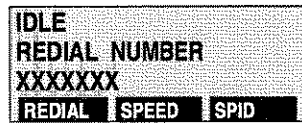

This will allow redial of a number that has been entered via the keypad.

SPEED Soft Key

If you select the "SPEED" soft key from the "HOOK" menu, the following menu will result:

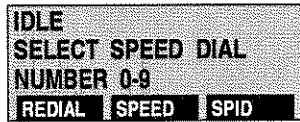

To use the Speed Dial function, simply select the "Store" menu single digit number under which your number is stored. To store a number for speed dialing, use the "*/Store" key.

Redial of the last number may be accomplished by pressing the "Redial" soft key.

NOTE: *Access to an ISDN line should be made prior to attempting to use the speed dial function. Speed dial will not work unless a number has been stored.*

SPID Soft Key

Selecting the "SPID" soft key from the "HOOK" menu will result in the following screen:

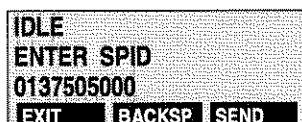

A Service Profile Identifier (SPID) is utilized by Terminal Equipment (TE) to request initialization from the switch on a multipoint circuit. This menu allows that identification number to be set or changed.

If the "Second Call" feature is ON, then "PH#1" will show in the upper-right.

Enter the SPID #1 for the first phone, press "**Scroll Menu**" and enter the SPID #2 for the second phone.

NOTE: *A second SPID is only needed if the line requires two SPID's.*

At present, for 5ESS, the SPID is formed by adding "01" to the beginning of the 7-digit number and followed with a "0". (As an example, "0137505000" is the SPID for Telephone Number 540-375-0500)

For NTI Functional, the SPID is the 10-digit primary directory number plus an optional two digit SPID suffix. (For example, "5403750500 00".)

The Terminal ID (TID) is required for National translations and is entered as part of the SPID. The TID is a two-digit number from 00 - 63. (For example, for 5ESS, "013750500011" would be the SPID for the number above, after adding "11" as the TID. For NTI, the SPID would be "54037505000011".)

Introduction

Status Menus

Testing may now be started by accessing the line by connecting the Model 550B to the appropriate interface. Pressing the "Hook On/Off" key will attempt to establish a call. Dial tone will be heard in voice service if the setup was correct. Please refer to the "Hook On / Off" section.

1/Status Key

Pressing "1/STATUS" on the keypad will result in the following menu:

STATES	=	INTERFACE
CAUSE	=	SWITCH INFO
RESULT	=	TIME/ERRORS
STATES	CAUSE	RESULT

The first three lines represent the menu. The fourth line represents the corresponding "Soft Key" selections available.

Moving from screen to screen can be accomplished by pressing the soft key corresponding to the choices of "STATES", "CAUSE" or "RESULT".

STATES submenu

Selecting the "**STATES**" soft key from the "**Status**" menu provides several screens to show the status of:

- M Channel Activity
- Layer 1
- Layer 2
- Layer 3
- Loopbacks on B1, B2, and 2B+D Status

NOTE *Moving from screen to screen is accomplished by either pressing the "**Scroll Menu**" key or the "soft key" corresponding to "**EXIT**", "**PREV**" or "**NEXT**". Menus may vary depending on the mode of operation.*

Selection of "**STATES**" from the "**Status**" menu will result in the following screen ("TE" or "NT1TE" mode):

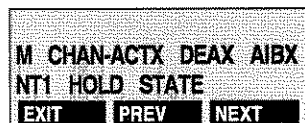

This menu provides Maintenance Channel information relative to the Activate Bit (ACT), the Deactivate Bit (DEA), the Alarm Indicator Bit (AIB), and the actual EOC messages received.

- ACT=1 is normal - (0 indicates not transparent to network)
- DEA=1 is normal - (0 indicates the network is going to deactivate)
- AIB=1 is normal - (0 indicates a problem)

Introduction

The second line displays the EOC message information. The EOC message will be addressed to "NT1" or "BROADCAST". The Actual EOC message received may be one of the following:

"2B+D LOOPBACK"
 "B1 LOOPBACK"
 "B2 LOOPBACK"
 "REQ CRPT CRC"
 "NOTIFY CRPT CRC"
 "RETURN NORMAL"
 "HOLD STATE"

Selection of the **"NEXT"** soft key or the **"Scroll Menu"** keypad button shows the following screen:

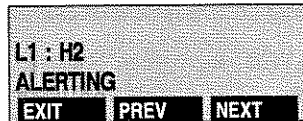

This is a menu which provides layer 1 diagnostic messages relative to the state of the U (Line) Interface.

For the "NT1/TE" Mode, the following information will be shown on the bottom line of the display:

2B1Q Messages which may appear:

"H1 FULL RESET" (Interface is being reset)
 "H2 ALERTING" (Interface is trying to alert network)
 "H6 ISW SYNC" (Sync has been found on inverted sync word)
 "H8 ACTIVE" (Interface is active)
 "H10 TEAR DOWN" (Interface in process of being torn down)

In the AMI line coding format, a N-channel is present, rather than the M-channel as in the 2B1Q coding format. Layer 1 messages are sent downstream from the network to a NT1 and upstream from a NT1 to the network. The States menu selection will show the messages outlined below, with "D" for downstream and "U" for upstream:

AT&T AMI N-Channel (Received) Downstream (D) Messages which may appear:

- "D 1 NT 2B+D LB" = Loopback 2B+D at NT1
- "D 2 NT B1 LB" = Loopback Chan. B1 at NT1
- "D 3 NT B2 LB" = Loopback Chan. B2 at NT1
- "D 6 ACT MODE/IDLE" = Activated Mode/Idle
- "D 8 ACT REQUEST" = Activation Request
- "D 15 DEACTIVATED" = Out of Service/Deactivated

AT&T AMI N-Channel (Sent) Upstream (U) Messages which may appear:

- "U 1 AWAKE INDICATION" = Request by TE to activate S/T Interface
- "U 6 ACTMODE/IDLE" = Idle condition
- "U 7 S/T NOT EST" = Lack of sync at S/T Interface
- "U 15 DEACTIVATED" = Out of Service/Deactivated

This is a menu which provides layer 1 diagnostic messages relative to the state of the S/T Interface. The second line will display the info states. This will be the first menu when in the NT1 mode:

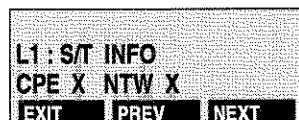

```
L1 : S/T INFO
CPE X NTW X
EXIT  PREV  NEXT
```

Introduction

Status/States Menus

The following information will be shown on the display for "TE" and "NT1" modes.

Combinations		Meaning
CPE	Network	
Info 0	Info 0	Just powered up (less than 1 second) or not working.
Info 1	Info 0	Terminal is waiting for framing from network. Network is down or there is a wiring problem. Line to switch is not operational.
Info 1	Info 2	Network initiating communication with TE.
Info 3	Info 4	Link to network is operational. Terminal should work. If not, there are potential translation problems.

Selection of the "NEXT" soft key or the "Scroll Menu" keypad button at this time results in the following screen:

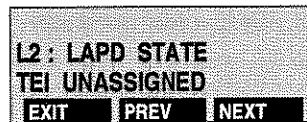

This is a menu which provides layer 2 information for link access protocol for the "D" channel. The second line will display the message.

Introduction

The complete messages and their meanings are indicated below:

- TEI UNASSIGNED - Requesting TEI state
- ASSIGN - Requesting TEI state
AWAITING TEI
- ESTABLISH - Requesting TEI state
AWAITING TEI
- TEI ASSIGNED - TEI has been assigned
- AWAITING - Not yet in multiple frame state
ESTABLISHMENT
- AWAITING - Release request from multiple
RELEASE frame state
- MULTIPLE - Completed SABME / UA (This is
FRAME the state the 550B should be in
ESTABLISHED when ready to place a call.)
- TIMER RECOVERY - Error State

Status/States Menus

Selection of the "NEXT" soft key or the "Scroll Menu" keypad button at this time results in the following screen:



This is a menu which provides layer 3 information for the state of actual calls. The second line will display the information. The following is a list of these messages and their meanings:

NULL STATE	- No call exists
CALL INIT (Call Initiated)	- The state exists for an outgoing call.
OVERLAP SENDING	- Call establishment request acknowledgement has been received permitting additional call information to be sent in the overlap mode.
OUT CALL PROC	- Outgoing Call Proceeding
CALL DELIVERED	- Remote user alerting has been initiated.
CALL PRESENT	- State exists for an incoming call.
CALL RECEIVED	- Incoming call not yet answered.
CONNECT REQUEST	- Incoming call answered, waiting to Be awarded.
IN CALL PROC	- Incoming Call Proceeding
CALL ACTIVE	- Incoming call or outgoing call state.

Introduction

- DISCONNECT REQ - (Disconnect request)
Request for network to clear the end-to-end connection.
- DISCONNECT IND - (Disconnect Indication)
Receipt of invitation to disconnect.
- SUSPEND REQUEST - Request for network to suspend the call.
- RESUME REQUEST- Request for network to resume a previously suspended call.
- RELEASE REQUEST Request for network to release a call.
- OVERLAP RECEIVE- (Overlap Receiving)
Network is prepared to receive additional call information (if any) in overlap mode.
- IDLE STATE - (IDLE CALL STATE) On Hook.
No calls in progress.

Selection of the "NEXT" soft key or the "Scroll Menu" keypad button at this time results in the following screen:

```
RX LOOPBACK STATUS
B1 OFF
B2 OFF 2B+D OFF
EXIT PREV NEXT
```

This illustration shows that all three loopbacks are not currently activated.

To exit the "1/Status" menu, press the "EXIT" soft key.

Introduction

CAUSE submenu

These sub-menus provide diagnostic information such as:

- Cause Information (CAUSE INFO)
- User Service Identifier (USID)
- Terminal Identifier (TID)
- Terminal Endpoint Identifier (TEI)
- B Channel Useage
- Automatic Number Identification (ANI)
- NTI Protocol Revision and Issue Number
(if supported by the switch)

NOTE *Moving from screen to screen is accomplished by either pressing the "Scroll Menu" key or the soft key corresponding to "EXIT", "PREV" or "NEXT".*

Selecting "**CAUSE**" from the "**Status**" menu will result in the following screen:

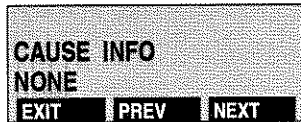

The second line of this screen will display the cause message, which may be one of the following:

"NONE" = No Cause Message received.

1 "UNASSIGNED NUM"	2 "NO ROUTE TO NET"
3 "NO ROUTE TO DEST"	6 "CHN UNACCEPTABLE"
7 "CALL AWARDED"	16 "NORMAL CLEARING"
17 "USER BUSY"	18 "NO USER RESPONSE"
19 "ALERTING NO ANS"	21 "CALL REJECTED"
22 "NUMBER CHANGED"	26 "NON SELECTED CLR"
27 "DEST OUT ORDER"	28 "INVALID NUM FMT"
29 "REQ FACILITY REJ"	30 "RSP TO STAT ENQ"
31 "NORM UNSPEC"	34 "NO CHAN AVAIL"
35 "QUEUED"	38 "NET OUT ORDER"
41 "TEMP FAILURE"	42 "NETWORK CONGEST"
43 "INFO DISCARDED"	44 "CHN NOT AVAIL"
47 "RESOURCE UNAVAIL"	49 "QUAL SVC UNAVAIL"
50 "FAC NO SUBSCRIB"	52 "OUT CALLS BARRED"
54 "IN CALLS BARRED"	57 "BEARCAP NOT AUTH"
58 "BEARCAP NOT AVAI"	63 "SERVC NOT AVAIL"
65 "BEARSVC NOT IMPL"	66 "CHN TYPE NOT IMPL"
69 "REQ FAC NOT IMPL"	70 "RES DIGITAL ONLY"
79 "SVC NOT IMLEMNT"	81 "INVAL CALL REF"
82 "CHN NOT EXIST"	83 "NO CALL ID"
84 "CALL ID IN USE"	85 "NO CALL SUSPEND"
86 "CALL CLEARED"	88 "INCOMPAT DEST"
91 "NET NOT EXIST"	95 "INVALID MSG"
96 "INFOELEMENT MISS"	97 "MSG TYPE NONEXST"
98 "MSG NOT COMPAT"	99 "ELEMENT NONEXIST"
100 "INVAL INFO"	102 "RECOV ON TMR EXP"
111 "PROTOCOL ERROR"	127 "INTERWORKING"

Introduction

Moving from screen to screen can be accomplished by either pressing the "**Scroll Menu**" key or by pressing the "soft key" corresponding to the choices of "**EXIT**", "**PREV**" or "**NEXT**".

Selection of the "**NEXT**" soft key or the "Scroll Menu" keypad button at this time results in the following screen:

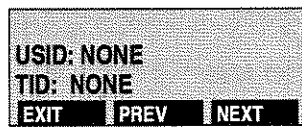

```
USID: NONE
TID: NONE
EXIT  PREV  NEXT
```

This menu will display the User Service Identifier (USID) and Terminal Identifier (TID) codes assigned, if any (TID required for NI-1), after access has been gained.



```
SERVICE PROFILE MGT.
DNXX: XXX XXXX
NEXTDN  PREV  NEXT
```

This menu is only valid for NTI-Functional. The above information (DN's assigned to each button number) will be displayed if the switch has SPM (Service Profile Management) information available. The second line "DNXX:XXX XXXX" translates to "key no.:DN". This menu can store up to 20 SPM messages. Pressing the "**NEXTDN**" soft key will review other key assignments.

Selection of the "NEXT" soft key or the "Scroll Menu" keypad button at this time results in the following screen:

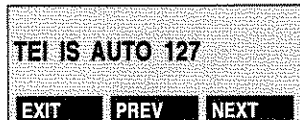

This menu will display the current mode (Auto or Fixed) and current assigned Terminal Endpoint Identifier (TEI) number.

Selection of the "NEXT" soft key or the "Scroll Menu" keypad button at this time results in the following screen:

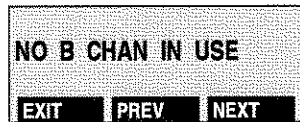

This menu reports which "B" Channel is in use, if any.

Selection of the "NEXT" soft key or the "Scroll Menu" keypad button at this time results in the following screen:



When an incoming call is received, this menu will display the calling party number on the second line, if the data received contains the calling party number. This menu can store up to 10 CLID messages. Pressing "NEXTID" will scroll through the messages.

Status/Cause Menus

Selection of the "NEXT" soft key or the "Scroll Menu" keypad button at this time results in the following screen:

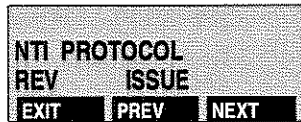

When turning up an NTI Functional Call Control circuit, you may wish to verify the correct protocol versions.

The revision and issue numbers of the protocol software for your particular "U" Interface DMS-100 translation will be displayed, if the switch supports this feature (otherwise they will remain blank).

To exit the "1/Status" menu, press the "EXIT" soft key.

RESULT submenu

Selecting "RESULT" from the "STATUS" menu will result in the following results screen (for example):

```
2B1Q NT1TE ERRORS
CRC ER XXX ES XXX
FEBE ER XXX ES XXX
NEXT
```

Selection of the "NEXT" soft key or the "Scroll Menu" keypad button at this time results in the following screen:

```
SET/START/STOP TIMER
00:10:00
00:10:00
EXIT START ERRORS
```

The first line is the time selected. The second line is the descending counter.

Enter the time desired by pressing the number keys on the keypad with the format of HH:MM. When ready to begin timed testing, press the soft key below "START" on this menu.

To display errors occurring and time left in the test, press the soft key below "ERRORS".

Movement between the "SET/START/STOP TIMER" and "ERRORS" screens can be accomplished by pressing "Scroll Menu" on the keypad or by using the "ERRORS" and "NEXT" soft key selections.

NOTE: *Timed tests will freeze the error counters after the time has expired.*

This timer is for the RESULTS screen only and is not valid for BER testing.

Test Results available for the various setups are:

- CRC ERR & CRC ES
- FEBE ERR & FEBE ES
- AMI FE & AMI FE ES
- NTI BPV & NTI BPV ES
- S/T FE & S/T FE ES
- S/T BPV & S/T BPV ES

To exit the "**Results**" menu, press any keypad selection, or press the "**EXIT**" soft key.

2/Auto Key

This key allows auto configuration to the "U" Interface, between the 2B1Q and AT&T AMI Interfaces. If you select item "**2/Auto**" on the keypad, the following screen will appear momentarily:



**AUTO SELECTING U
INTERFACE**

When the Line Interface has been evaluated, the unit setup configuration will be changed to reflect the interface evaluated and the LCD screen will report that configuration, for example:



**AUTO COMPLE
SELECTED 2B1Q**

To exit the "**2/Auto**" menu, press "**Setup**" or "**Hook On/Off**".

3/BERT Key

This key allows Bit Error Testing on either of the "B" Channels (when optioned for Data Capability).

If you select item "3/BERT" on the keypad, the following menu will result:

```
BERT 2047 B1 64K
          BE 0
TIME 00:00:00 ES 0
STRCLR STOP 6ERROR
```

The channel and data rate currently selected for the first call will be displayed on the first line.

NOTE: *If the "Data Capability" option has not been ordered, the menu will display "NOT OPTIONED".*

You may select the another B Channel by pressing the "Scroll Menu" key. The following menu will result:

```
BERT 2047 B1 64K
          BE 0
TIME 00:00:00 ES 0
EXIT B1 B2
```

You may select the desired data rate (56 or 64) by pressing the "Scroll Menu" key. The following screen will then be displayed:

```
BERT 2047 B1 64K
          BE 0
TIME 00:00:00 ES 0
EXIT 56 K 64 K
```

Pressing "Scroll Menu" moves back to the timed test display above.

Introduction

Testing will begin when you depress the "**STRCLR**" (start and clear) soft key. Bit Errors and Errored Seconds will be displayed.

NOTE: *It is normal to get a burst of errors when a test is first started. Press "**STRCLR**" again to clear the errors.*

The "**6ERROR**" soft key may be used to insert 6 bit errors into the transmitted data.

NOTE: *Please note that when 6 bit errors are inserted into the transmitted data, they may or may not fall within the same errored second. The use of the "**6ERROR**" soft key might result in two errored seconds.*

You may change the B Channel or data rate by pressing the "**Scroll Menu**" keypad button until the proper menu is displayed.

Testing will terminate when you press the "**STOP**" soft key. Going "On Hook" will also stop the BERT test.

To exit this menu, use the "**Scroll Menu**" keypad button until the menu shows a soft key selection of "**EXIT**". Press this soft key. You may also press the "**Setup**" key, then the "**ACCEPT**" soft key.



BER Testing

To conduct BER Testing, perform the following:

- 1) Press the **"#/Utility"** key.
- 2) Press the **"DATA"** soft key, then **"Scroll Menu"** until the "BEARER CAP" menu is displayed.
- 3) Select **"DATA"**. Then press the **"Scroll Menu"** key and **"EXIT"** soft key.
- 4) Place a call:
 - A - Go off hook by pressing the **"Hook On/Off"** key ("Off Hook" LED will light).
 - B - Enter the number using the keypad (LCD screen will display number entered and channel connected).
- 5) Press **"2nd Func."** followed by **"BERT"**.
- 6) Check the Speed and B-Channel.
 - B-Channel should be the B-Channel shown when the call was connected.
 - Speed should be 64K for Clear Channel Testing and 56K for Non-Clear.
- 7) Start the BER Test by pressing the **"STRCLR"** soft key. There will be a burst of bit errors (BE).
- 8) Press the **"STRCLR"** soft key again to clear the initial errors. Press the **"6ERROR"** soft key to insert 6 bit errors into the transmit pattern.

Introduction

- 9) Run the test for a desired amount of time and determine if total errors is acceptable (see your company policy).
- 10) Press the **"STOP"** soft key or **"Hook On/Off"** twice to end the test.

The dual call feature of the Model 550B enables BER tests to be conducted on both B-channels simultaneously, thus testing the full 128K bandwidth. This testing can be accomplished in two scenarios.

LOOPBACK:

With each B-channel having a dialable number, turn the "Second Call" feature ON in the **"Utility, MODES"** menus, **"EXIT"** to the ON HOOK screen, select **"SPID"** soft key, and enter SPID #1 and SPID #2. Return to the Hook screen for PH#1 (Phone 1) and press **"Scroll Menu"** to reach the PH #2 Hook screen. Wait approx 15 seconds for Phone #2 to initialize. Go Off Hook and dial the number for phone #1.

When the sonalert is heard, press **"Scroll Menu"** to move to Phone #1, press the **"Hook On/Off"** key to answer the call. Place the "called" B-channel into loopback mode, enter the BERT menu, and start a test over the "calling" B-channel (the PH#2 B-channel).

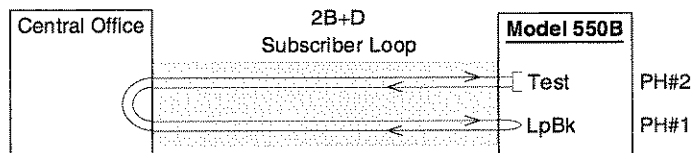

Introduction

NOTE: *If the "Second Call" feature is ON, a call can be placed out to the switch and back to the second B-channel. Then one of the channels may be placed in loopback ("Utility" menu, "Config" sub-menu, "Loopbacks Select" display), and BERT testing initiated over the other B-channel. Thus, both B-channels can be tested at the same time.*

STRAIGHTAWAY:

In the same manner as above, two technicians with Model 550B's can call each other. In this scenario, the first would call the second technician. The second technician would then call the first, using the PH#2 Hook screen. The called technician would place the incoming B-channel in loopback. Each technician would then initiate BER testing over the out-bound B-channel.



Introduction

***/Store Key**

This key allows frequently used numbers to be stored for future speed dial applications.

If you select item ****/Store** on the keypad, the following screen will result:

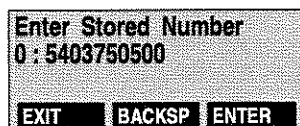

The last number stored in Position "0" will be displayed. If no number has been stored yet in position "0", the display will read "0:". To save a newly entered number, press the **"ENTER"** soft key. Up to ten numbers may be stored for future speed dial applications by pressing the **"Scroll Menu"** key.

The **"Scroll Menu"** key will increment the stored number counter, allowing you to access all of the stored numbers.

If a mistake is made, the cursor can be backspaced by pressing the **"BACKSP"** soft key.

To change a stored number, you may exit and re-enter the **"STORE"** menu or use the **"Scroll Menu"** key to step past the end of the list of numbers and back to the desired location - at which time the new number may be entered.

An example of a frequently used number you may want to store would be the local BRITL (BRI Dial-Up Test Line) access number.

To exit the **"STORE NUMBER"** menu, press the **"EXIT"** soft key.

Introduction

#/Utility Key

Pressing this key causes the following menu to be displayed, allowing various utility functions to be performed.

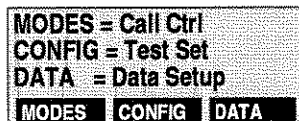

MODES submenu

Pressing the "MODES" soft key from the "Utility" menu will allow the following configuration changes to be made:

- | | |
|-----------------------------|---|
| EBS Station Address Feature | - A device's individual address |
| | - Switch Verification of translation (On / Off) - only for BRITL in 5ESS custom |
| Second Call | - Dual Call feature (On / Off) |
| Dual TEI | - Dual TEI (On / Off) |
| Call Control | - 5ESS, DMS-F, or optional NAT'L |
| B Channel Selection | - B1, B2, or Any |
| Call Appearance | - 1 through 254 (specified with keypad, then "ENTER" soft key) |
| TEI | - Auto or Manual |

NOTE: *The current setup will determine which of the previous menus will be displayed. Not all of these menus will be valid for all setups.*

Introduction

Moving from screen to screen can be accomplished by pressing the "**Scroll Menu**" keypad button.

If in EBS mode, pressing the "**MODES**" soft key from the "**Utility**" menu will result in the following menu:

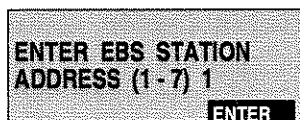

The EBS station address is used when more than one device is connected to the EBS line at the customer premise. Each device would have its own address in order to communicate with the switch.

If in any mode other than EBS, pressing the "**MODES**" soft key from the "**Utility**" menu will result in the following menu:

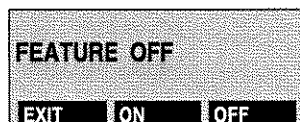

This menu allows switch feature verification for AT&T 5ESS switches when using the BRITL capability.

A Basic Rate Interface Dial-Up Test Line (BRITL) feature of AT&T switches provides a means by which the craftsperson can test operation of a BRI (Basic Rate Interface) from the customer side (CPE) of a BRI. By placing a test call to a pre-assigned Directory Number, the craftsperson may gain access to a set of test commands via the CPE keypad, e.g., the Model 550B keypad. These commands will allow the Basic Rate Interface to be tested without additional craft support at the Central Office.

When the "ON" soft key is pressed, switch feature verification will be enabled. At this point, any button number may be entered via the keypad, followed by "#". The LCD will then display what that button number has been translated for by the switch. This procedure may be repeated for other button numbers.

To exit the "FEATURE VERIFICATION" menu, press the "EXIT" soft key.

To use the Model 550B to go off hook and dial the BRI Test Line access code:

- 1 - Press the "Hook On/Off" key to go off hook
- 2 - Upon hearing dial tone, dial the BRI Test Line access code using the keypad
- 3 - A secondary dial tone will be heard and a display message will indicate successful origination of the Test Line
- 4 - BRI Dial-Up Test Line keypad codes may now be used to exercise the set of commands available

NOTE: *The BRITL Access Number may be conveniently stored in one of the speed dial locations for quick recall (access).*

Utility/Modes Menus

Valid BRI Dial-Up Test Line (BRITL) keypad codes are as follows (when the switch is provisioned with 5E6 software generic or above):

KEYPAD	ACTION
*11X#	Run BER Test on Channel X with Current Parameter
*120#	Display Current Test Termination
*12X#	Set Test Termination
*130#	Display Current Test Duration
*13X#	Set Test Duration
*140#	Display Current Test Data Rate
*14X#	Set Test Data Rate
*2#	Send Alerting Signal to the CPE
*3#	Print LCEN on CPE display
*4#	Print Primary DN/MLHG on CPE display
*0#	Repeat Previous Message (Display/Tone)

As an example, enter "***3#**" on the keypad. The Line Card Equipment Number of the BRI will be displayed on the Model 550B LCD screen.

Introduction

Valid BRI Dial-Up Test Line (BRITL) parameters are listed below:

COMMAND SUFFIX	KEYPAD CODE	KEYPAD CODE	KEYPAD CODE	KEYPAD CODE
X	*11X	*12X	*13X	*14X
1	B1	CPE	20 Sec.	64K Clear
2	B2	NT1	2 Min.	64K Restrict.
3		Line Card	20 Min.	56K
41		BRITE CU1		
42		BRITE CU2		
43		BRITE CU3		
44		BRITE CU4		
45		BRITE CU5		
46		BRITE CU6		

Pressing "**Scroll Menu**" will move to the "Second Call" (or dual call) feature selection display:

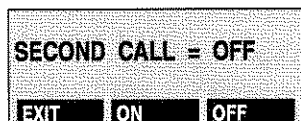

Selecting "**ON**" enables the test set to allow dual call capability. This allows the Model 550B to handle two calls at the same time using both B-channels (B1 and B2).

Introduction

Pressing "**Scroll Menu**" with Second Call ON moves to the TEI mode display (if Second Call "Off", "Call Control" menu will display):



"**ON**" would normally be selected unless in a 5ESS Pt-to-Pt setup. This menu will be displayed only if the "Second Call" is enabled.

DUAL CALL Feature

There are two configurations or "Setup" selections used in making a "Dual B-Channel" call. They involve the use of the TEI (Terminal Endpoint Identifier) selection as single or dual and the use of one or two SPID's (Service Profile Identifier), described below:

Two B-Channel Calls with the 5ESS switch:

Lines configured as Point-to-Point configuration, custom or National ISDN, use one TEI and one SPID to establish a dual B-Channel data call. Dual B-Channel voice calls are not allowed.

Lines configured as multi-point configuration, custom or National ISDN, use two TEI's and two SPID's. Voice or Data bearer service is allowed.

Two B-Channel Calls with other switches:

All other switches, whether in Custom call control or not, require the use of two SPIDs. Both Voice and Data bearer service is allowed.

Introduction

Test Set Configuration:

- 1) Use the "**Setup**" key to configure the test set for the line under test.
- 2) Press the "**Utility**" key and select the "**MODES**" soft key.
- 3) Use the "**Scroll Menu**" key to move to the "SECOND CALL" screen. The Model 550B defaults to OFF. Select "**ON**".
- 4) Use "**Scroll Menu**" to move to the "DUAL TEI MODE" screen. The selection must be ON unless the line under test is a 5ESS Point-to-Point configuration.
- 5) Press the "**EXIT**" soft key to move to the HOOK screen.
- 6) Press the "**SPID**" soft key and check SPID #1.
- 7) Press the "**ENTER**" soft key after checking SPID #1 which moves to the ENTER SPID #2 screen. Enter SPID #2, if needed.
- 8) Press the "**EXIT**" soft key to return to the HOOK screen for PH #1 (Phone number 1). Press "**Scroll Menu**" to move to PH #2 which will initialize the second "phone". Pressing "**Scroll Menu**" moves back and forth between the PH #1 and PH #2 HOOK screens.

Introduction

Pressing "**Scroll Menu**" moves to the Call Control selection display:

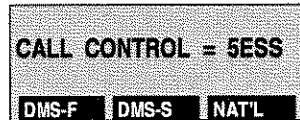

This utility menu allows a specific call control to be selected, including "DMS-S" (Northern Telecom-Stimulus). The current call control will be displayed. The "DMS-S" selection is not included in the "Setup" menu selection since it is seldom used.

Pressing the "**Scroll Menu**" key at this time will result in the following menu being displayed:

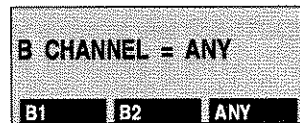

This menu indicates that the default is either B Channel. To choose a channel for outgoing calls, press the corresponding soft key. (This is not valid for NTI Stimulus Call Control; B-Channel selection is not allowed.)

NOTE: *You will be denied if you choose a B channel that the translation of that line doesn't support.*

Pressing the **"Scroll Menu"** key at this time will result in the following menu being displayed:

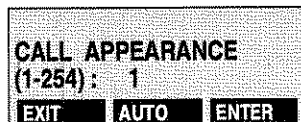

For 5ESS Custom Call Control, this menu allows the user to place outgoing calls on button numbers selected, other than 1 which is the default setting. **"AUTO"** may be pressed to automatically search for the first call appearance on the line under test.

For DMS-F (Northern Functional) or NAT'L (National ISDN) Call Control, this menu allows a selection for a call appearance. The middle soft key, "AUTO," will be replaced with "NONE". A Northern Functional Directory Number may also be needed. This number is entered by pressing the "Setup" key, then scrolling to "ENTER DIRECTORY NUMBER". Enter the number and return to the Hook screen to place a call.

Pressing the **"Scroll Menu"** key at this time will result in the following menu being displayed:

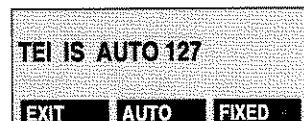

You may change the TEI status by selecting the proper soft key (**"FIXED"** or **"AUTO"**). When you change to a fixed TEI, you can enter the new TEI using the keypad. In this way, you may also use this menu to change a previous TEI.

Pressing **"Scroll Menu"** will wrap around to the first menu (Feature On/Off); **"EXIT"** will exit to the HOOK screen.

Introduction

CONFIG submenu

Selecting "**CONFIG**" from the "**Utility**" menu will allow the following configuration changes to be made:

- Firmware revision - This screen reports the revision of firmware that is present in this unit and which interfaces are installed.
- LCD Backlight - Toggle backlighting on and off using soft keys.
- U Interface Mode - Select "Line Termination" or "Network Termination" mode using soft keys.
- EOC Message (for LT mode) - Select the address and message to send.
- Battery Level indication - This screen shows the battery charge state.
- Automatic Power Down - Enable or disable the automatic power down feature
- Volume Level - Adjust the level of the "Hands Free" volume using soft keys.
- LCD Contrast - Adjust the contrast of the LCD Display using soft keys.
- Toggle Loopbacks - Toggle loopbacks on and off for B1, B2, and 2B+D using soft keys.
- Loss Insertion - Increase / decrease the dB loss on the "U" pad using soft keys.
- 2B1Q 40KHz Tone - Turn 40KHz tone generation on/off when in 2B1Q NT1/TE or 2B1Q NT1. Signal level is 0dBm.

Moving from screen to screen can be accomplished by pressing the "**Scroll Menu**" keypad button.

Introduction

Pressing the "CONFIG" soft key from the "Utility" menu will result in the following screen, showing the firmware revision, and available interfaces:



The check mark (✓) will indicate which interfaces are installed. "N" following the firmware version number indicates NI-1 call control is installed.

Pressing the "Scroll Menu" keypad button at this time will result in the following screen:

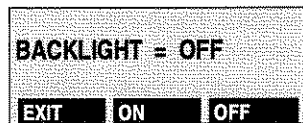

By pressing the "ON" or "OFF" soft keys, you can turn the LCD display's backlighting on or off.

NOTE: *Battery life will be enhanced if the LCD Backlighting is turned off when not needed (i.e., when there is sufficient ambient light).*

Pressing the "Scroll Menu" keypad button at this time will result in the following screen:



This menu is used to select "Line Termination" (LT) or "Network Termination" (NT) mode for the 2B1Q interface; "NTMODE" is the default setting. Press "LTMODE" to change the mode.

In the "NT" mode, the Model 550B 2B1Q "U" Interface operates as it always has, looking like an NT1 to the switch. However, in the "LT" mode, the Model 550B 2B1Q "U" Interface will act like a Switch Line Card.

The "LT" mode can be used to do Layer 1 qualification of copper facilities. When a Model 550B is in the "LT" mode on one end of a pair of wires, and another Model 550B is in the "NT" mode on the other end, the Model 550Bs will sync on each other and Layer 1 testing can take place by performing a BERT test on B1 and B2 from each Model 550B to the other, or by checking for CRC and FEBE errors on each set under the "Results" menu.

If "NTMODE" is selected, the battery status menu will display.

If "LTMODE" is selected, the next menu will be the following:

```

✓ ADDRESS 0 NT1
✓ MESSAGE =
  RETURN TO NORMAL
ADDRESS  MESSAGE  EXIT
  
```

This menu allows selection of the address (0-7) and message to be sent. The check marks (✓) indicate the last setting. The message may be one of the following:

```

RETURN TO NORMAL
HOLD STATE
2B+D LOOPBACK
B1 LOOPBACK
B2 LOOPBACK
REQ CORRUPTED CRC
NOTIFY CORRUPT CRC
  
```

NOTE: *The NT1 is always address 0. A mid-span repeater, address 1, may also be controlled for loopbacks*

Press "SEND" to send the message.

Introduction

Pressing the "**Scroll Menu**" keypad button at this time will result in the following screen:

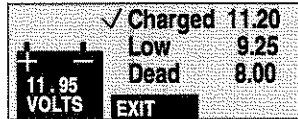

The three numbers on the right screen serve as a guideline in determining the battery charge status. The actual battery voltage appears inside the picture of the battery, on the left side of the screen.

The check mark indicates the status of the internal battery as determined by the voltage compared to the guidelines. In this case, the battery is charged.

Pressing the "**Scroll Menu**" keypad button at this time will result in the following screen:

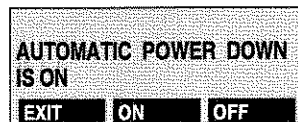

The Auto Power Down feature enables the set to turn itself off to conserve battery life if there is no activity for 5 minutes (10 minutes in EBS/POTS modes). This menu is not applicable if the AC Adapter is used.

Pressing the "**Scroll Menu**" keypad button at this time will result in the following screen:

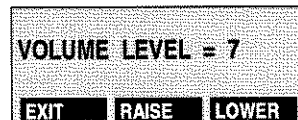

You may adjust the volume level with the "**RAISE**" and "**LOWER**" soft keys. The default volume level is "7". Please note that this volume level pertains to the "Hands-Free" feature only, and does not affect the handset volume level.

Introduction

Utility/Config Menus

Pressing the "Scroll Menu" keypad button at this time will result in the following screen:

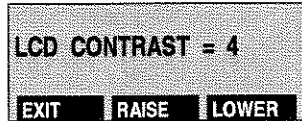

You can change the LCD screen contrast by pressing the "RAISE" and "LOWER" soft keys, to optimize the display's readability for your current lighting conditions.

NOTE: *The contrast needed will depend on your current lighting conditions*

Pressing the "Scroll Menu" keypad button at this time will result in the following screen:

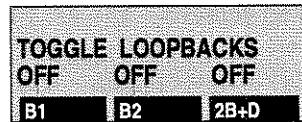

By pressing the soft key under each of these selections, you may toggle them On and Off.

Pressing the "Scroll Menu" keypad button at this time will result in the following display:

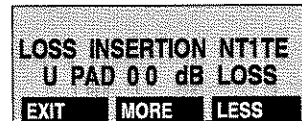

Up to 15 dB of loss may be inserted on the "U" interface by pressing the "MORE" soft key until the desired number is displayed.

Pressing the "**Scroll Menu**" keypad button at this time will result in the following display:

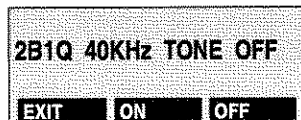

Press the "**ON**" soft key to generate a 40 KHz tone, at approx. 0dBm, in 2B1Q NT1/TE or 2B1Q NT1 modes. The test tone is a sine wave signal that approximates the Nyquist frequency of the 2B1Q signal.

Pressing "**Scroll Menu**" will wrap around to the first menu (Firmware ver./interfaces); "**EXIT**" will exit to the HOOK screen.

DATA submenu

Selecting "**DATA**" from the "**Utility**" menu will allow the following data configuration changes to be made:

- | | |
|-------------------------|---|
| D-Channel Monitoring | - Turn On or Off D-Channel Monitoring |
| Flow Control | - Turn On or Off flow control for the D-Chan. Monitor |
| Bearer Capability Speed | - "VOICE", "DATA", or "PACKET"
- "56K", "64K", or "SBRATE" (only valid for "DATA" setting) |
| Call User Data | - Manually enter the Call User Data for a Packet Data call. |
| Logical Channel Number | - Manually enter the LCN (0-15) for a Packet Data call. |
| Closed User Group | - Manually enter the CUG (0-9999) for a Packet Data call. |
| Reverse Charge | - Turn On or Off the Reverse Charge option for a Packet Data call. |
| RPOA | - Manually enter the Registered Private Operating Agency for a Packet Data call. |

Moving from screen to screen can be accomplished by pressing the "**Scroll Menu**" keypad button.

Introduction



Selecting "DATA" from the "Utility" menu will result in the following display:

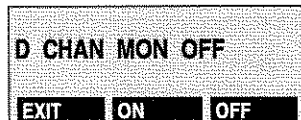

NOTE: *If the Model 550B is operating in the "EBS" mode, the display will read "SIGNAL CHAN MON OFF"*

Monitoring of "D" channel (or "Signal" channel) packet data is available with remote equipment via a dB9/RS-232 connector on the front panel (when optioned).

To enable the RS-232 "D" packet data monitor function (9600,8,N,1,DTE), press the "ON" soft key.

Pressing "Scroll Menu" will result in the following menu:



From this menu, you may turn flow control "ON" or "OFF". Selecting "ON" will enable data flow with hardware handshake by CTS pin 5.

NOTE: *This only affects the D-Chan Monitor.*

Pressing the "Scroll Menu" keypad button at this time will result in the following screen:

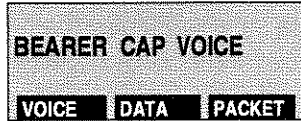

From this menu, you may change the type of call to place with the soft keys.

This menu allows the user to choose between placing a voice call and setting up a circuit-switched data call or D-Channel Packet Call. The voice/data selection is stored on power down.

Selection of "DATA" from this menu gives the user access to three types of circuit switched data calls, 56Kbps, 64Kbps, and subrate.

Selection of "PACKET" from this menu will allow D-Channel Packet data calls.

In D-Channel Packet Data mode, Call User Data, LCN (Logical Channel Number), CUG (Closed User Group), Reverse Charge, and RPOA (Registered Private Operating Agency) may also be selected.

NOTE: *The Model 550B supports a window size of "3" and Modulo 8 for D-Channel Packet calls.*

Data calls are placed using the "Hook On/Off" menu, in a process similar to that of placing a voice call. Dial tone may not be audible, but states will be indicated by LCD message on the second line.

Pressing the "Scroll Menu" keypad button at this time will result in the following screen:



From this menu, you may change the data speed to 56K, 64K, or Subrate. The last setting on power down will be displayed.

NOTE: *Only valid for DATA bearer channels*

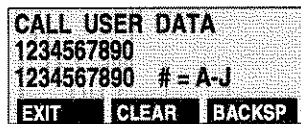

Pressing the "Scroll Menu" keypad button at this time will result in the following screen:

This menu allows input for Call User Data (CUD) when making D-Packet calls; if nothing is entered via this menu, D-Packet Calls are handled in the normal manner.

The telephone number for the D-Packet call should be entered first by dialing the number (using the keypad). A semicolon ";" should then be entered as a separator by pressing the "#" key five times, until the ";" selection becomes available, then selecting the ";" separator by pressing the "0" key. Data that is entered using this method will appear on the display.

Following the ";", up to twelve (12) characters of CUD can be entered by using the same procedure as entering the ";". Once the twelve character CUD limit is reached, no more entries can be made. If a mistake is made, the "BACKSP" key is used to backspace/delete information entered. After entering data, this menu can be exited by "Scroll Menu".

Introduction

After entering data via this menu, going off hook in the D-Packet Mode sends the entire number and CUD automatically. On power down, the CUD information is retained and will be present in the menu the next time it is accessed. It is important to note that if there is stored CUD information, any time a D-Packet call is made the CUD and number will automatically be dialed. To clear the CUD buffer you must be in the CUD menu and press "**BACKSP**" to backspace/delete all numbers and CUD information or press "**CLEAR**," then exit the menu.

You may enter the Call User Data, which may contain upper and lower case characters, numbers, spaces, equal signs, colons, and semicolons.

To enter a numeric digit, press the corresponding keypad button. If you wish to enter a letter from "A" through "J" (upper case), or any other character, press the "#" keypad button, and the following screen will appear:

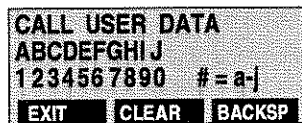

To enter an upper case letter from "A" through "J", press the corresponding numeric keypad button, as per the table on this screen.

To enter a lower case letter from "a" through "j", or any other character, press the "#" character to display the next set of characters. The following will result:

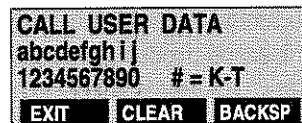

Any of the first ten lower case letters may be selected from this screen, or you may advance to the next screen by pressing the "#" key.

As you make your character selections and build the desired string of characters, the string will appear on the right side of the LCD display. If you make a mistake in entering the character string, you may erase one digit at a time with the "BACKSP" soft key or "CLEAR" to clear the entire entry.

When the desired character string is completed, you may store it and exit this set of menus by pressing the "EXIT" soft key or the "Scroll Menu" keypad button.

Packet Data call options may be selected as follows:

1. Press "Scroll Menu" to set the LCN (0-15):

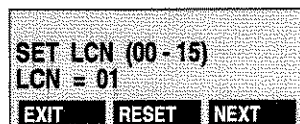

The Logical Channel Number may be selected in a range of 0-15, with 1 being the default setting if no other selection is made.

NOTE: *The Model 550B uses a LCGN (Logical Channel Group Number) of "0".*

2. Press the "NEXT" soft key or "Scroll Menu" to select the CUG (0-9999):

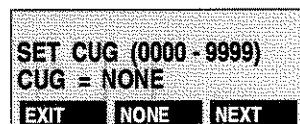

The Closed User Group number may be selected in a range from 0 to 9999. "NONE" is the default setting.

- 3. Press the "NEXT" soft key or "Scroll Menu" to select the Reverse Charge option:

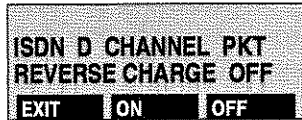

The default setting is "OFF".

- 4. Press "Scroll Menu" to select the RPOA (Registered Private Operating Agency) option:

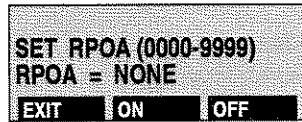

The RPOA code may be entered at this point. The default setting is "NONE".

NOTE: *The Model 550B supports a window size of "3" and Modulo 8.*

Pressing "Scroll Menu" will wrap around to the first menu (D Chan Mon On/Off); "EXIT" will exit to the HOOK screen.

Hook On/Off Key

HOW TO MAKE A VOICE CALL

Complete the **SETUP** menu selections including the correct mode, line code, call control, SPID, directory number, and TEI **before accessing the line under test.**

ISDN switches may take up to a minute to initialize when access is gained and/or when a mode change takes place. If the "**Hook On/Off**" key is pressed during this initialization period, a "**WAITING FOR RESPONSE**" message may be displayed.

- 1) GO OFF HOOK by pressing the "**Hook On/Off**" keypad button (will hear dial tone).
- 2) ENTER THE NUMBER using the keypad (LCD screen will display number entered and channel selected).
- 3) CONVERSATION may now take place using the "**Hands Free**" feature (an external handset may also be connected).

TO END a Voice Call, go **On Hook** by pressing the "**Hook On/Off**" keypad button.

TROUBLESHOOTING TIPS

- 1) For most circuits, the "**SPID**" **must be entered** prior to going off hook (use "**Setup**" soft key).
- 2) "**TEI**" **assignment** must have been made before a dial tone can be heard. (Check for "**Ready**" LED or use the "**Status/States**" menu to verify Layer 2 state).
If TEI is assigned, LCD = "MULT FRAME EST"
If TEI is not assigned, LCD = "TEI UNASSIGNED".
- 3) If dial tone has not been gained, a cause message will be displayed on the LCD. For more information, the "**Status**" menu can be accessed to view the **CAUSE INFO**, which will give a diagnostic cause message.
- 4) If set-up needs to be checked, press the "**Setup**" keypad button, which will prompt the operator to answer several setup related questions that will configure the Model 550B to the circuit and switch being accessed.

NOTE: *The switch type must be selected, and the TEI (Terminal Endpoint Identifier) may need to be set. Please refer to the "Setup" menu.*

*ISDN Switches may take up to a minute to initialize when access is gained and/or when a mode change takes place. If the "**Hook On/Off**" key is pressed during this initialization period, a "WAITING FOR RESPONSE" message may be displayed.*

If you select item "Hook On/Off" on the keypad, the following screen will be shown:

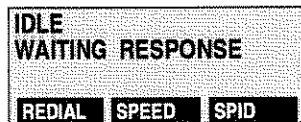

The first line represents the 550B state. The second line represents the switch state.

The Model 550B will pause to communicate with the switch. You will then hear the dial tone, and the "STATE" will change to "DIAL TONE" and the following menu will result:

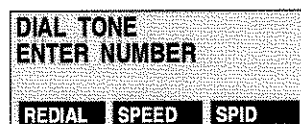

The number may now be entered from the keypad. While the number is being dialed, "DIALING" is displayed, and as the call goes out, "RINGBACK" or "CALL PROCEEDING" is displayed. When the other end answers, the following menu will result:

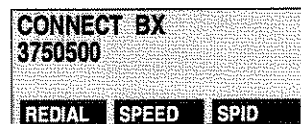

"BX" reflects the current B-channel. "3750500" reflects a number that was entered.

This menu reflects a successful connection and conversation may take place utilizing an external handset connected or the handsfree feature provided by the Model 550B.

The normal sequence followed by the ISDN 550B Portable Test Set when making a voice call will be as indicated below:

- 1 - IDLE
- 2 - DIAL TONE
- 3 - DIALING
- 4 - CALL PROCEEDING
- 5 - CONNECT
- 6 - RELEASING
- 7 - IDLE

NOTE: *During a call, if the other end terminates a call, the Model 550B will automatically go to "On Hook" status.*

The Model 550B will display the normal call sequence messages listed earlier to indicate call status, along with other status messages such as "Connect", "Ringback", and "Ringing". The meaning of these messages is reviewed below:

- | | |
|-----------------|--|
| IDLE | - Hung up. |
| DIAL TONE | - The switch has sent a message saying we have a dial tone. |
| DIALING | - In the process of dialing digits as entered. |
| CALL PROCEEDING | - Placed a call and the switch is ringing the other end, which has not yet answered. |
| RELEASING | - Sent the disconnect message to the switch. |
| CONNECT | - Received message from switch that call has been put through. |
| RINGBACK | - Placed a call and the switch is ringing the other end, which has not yet answered. |
| RINGING | - Receiving an incoming call (go OFF HOOK to answer). |

Introduction

HOW TO MAKE A DATA CALL

Complete the **SETUP** menu selections including the correct mode, line code, call control, SPID, directory number, and TEI **before accessing the line under test.**

ISDN switches may take up to a minute to initialize when access is gained and/or when a mode change takes place. If the "**Hook On/Off**" key is pressed during this initialization period, a "**WAITING FOR RESPONSE**" message may be displayed.

If placing a call to an extended DataPath 2 wire or a 4 wire switched 56 circuit, you may need to start BERT at 56K on the appropriate "B" channel before placing a call. This will keep Bit 8=1 (off hook) so the call won't be disconnected inadvertently due to voice data on the B-Channel.

NOTE: If the "Second Call" feature is used, two SPID's must be entered unless the call setup is "5ESS, Pt-to-Pt, Data call". In that case, one SPID only is required.

- 1) Press the **"#/Utility"** keypad button.
- 2) Press the **"Data"** soft key. The **"BEARER CAPABILITY"** sub-menu is gained.
- 3) Select **"DATA"**.
- 4) A Circuit Switched Data Call may now be placed, just like a voice call.
 - A - GO OFF HOOK, by pressing the **"Hook On/Off"** keypad button (may hear dial tone).
 - B - ENTER THE NUMBER, using keypad (LCD screen will display number entered and channel connected).
- 5) BER Testing may now take place.
 - A - Press **"2nd Func."** followed by **"BERT"**.
 - B - Make sure the Speed and B-Channel are correct.
 - The B-Channel should be the B-Channel shown when the call was connected.
 - The Speed should be 64K for Clear Channel Testing and 56K for Non-Clear.
 - C - Start the BER Test by pressing **"STRCLR"**. (There will be a burst of bit errors [BE])
 - D - Press **"STRCLR"** again to clear the initial errors. Press **"6ERROR"** to insert 6 bit errors into the transmit pattern.
 - E - Run the test for a desired amount of time and determine if total errors is acceptable (see your company policy)
 - F - Press the **"STOP"** soft key to end the test.

TO END a Data Call, Go **On Hook** by pressing the **"Hook On/Off"** keypad button.

Introduction



TROUBLESHOOTING TIPS

- 1) It is best to verify that a Voice Call can be made successfully, prior to attempting a Data Call.
- 2) The "**SPID**" **must be entered** prior to going off hook (use "**Setup**" key).
- 3) "**TEI**" **assignment** must have been made before going off hook. (Check for the "**Ready**" LED or use the "**Status/States**" menu to verify Layer 2 state).
 If **TEI is assigned**, LCD = "**MULT FRAME EST**"
 If **TEI is not assigned**, LCD = "**TEI UNASSIGNED**".
- 4) If dial tone has not been gained, a cause message will be displayed on the LCD. For more information, the "**Status**" menu can be accessed to view the **CAUSE INFO**, which will give a diagnostic cause message.
- 5) If set-up needs to be checked, press the "**Setup**" keypad button, which will prompt the operator to answer several setup related questions that will configure the Model 550B to the circuit and switch being accessed.

If the Model 550B is optioned for data capability, the **"Utility"** menu will allow the user to choose between placing a voice call, and setting up a Circuit-Switched Data call or D-Channel Packet Data call.

For Circuit-Switched Data calls, the **"Utility"** menu gives the user access to three types of calls, relating to choices for service and speed:

- 1) 56000 BPS
- 2) 64000 BPS
- 3) Subrate

Once the "UTILITY" menu has been used to select "Data", service type and speed, a Circuit-Switched Data call may now be placed by using the **"Hook On/Off"** menu, just like a Voice call.



HOW TO MAKE A D-CHANNEL PACKET CALL

Complete the **SETUP** menu selections including the correct mode, line code, call control, SPID, directory number, and TEI **before accessing the line under test.**

ISDN switches may take up to a minute to initialize when access is gained and/or when a mode change takes place. If the "**Hook On/Off**" key is pressed during this initialization period, a "**WAITING FOR RESPONSE**" message may be displayed.

- 1) Press the "**#/Utility**" keypad button.
- 2) Press the "**Data**" soft key. The "**BEARER CAPABILITY**" sub-menu is gained.
 - Select "**PACKET**".
- 3) Press the "**Hook On/Off**" keypad button (the LCD display will indicate "ENTER NO. W/KEYS").
- 4) **ENTER THE NUMBER** using the keypad.
- 5) Press the "**#/Utility**" keypad button to send the call (LCD top line = "**D-PACKET CONNECTED**").
- 6) Press the "**1/Status**" keypad button to send the following message over the D-Channel "01:The red fox jumped over the lazy dog." Each time "**1/Status**" is pressed, the message will be sent with the number incrementing with each press. Press "**2/Auto**" to clear the message.
- 7) The Model 550B will display any information coming to it on the LCD screen.

TO END a D-Channel Packet Data Call,
Go **On Hook** by pressing "**Hook On/Off**".

Introduction

TROUBLESHOOTING TIPS

- 1) It is best to verify that a Voice Call can be made successfully, prior to attempting a D-Packet Call.
- 2) The "**SPID**" **must be entered** prior to going off hook (use "**Setup**" soft key).
- 3) "**TEI**" **assignment** must have been made before a dial tone can be heard. (Check for the "**Ready**" LED or use the "**Status/States**" menu to verify Layer 2 state).
If TEI is assigned, LCD = "MULT FRAME EST"
If TEI is not assigned, LCD = "TEI UNASSIGNED".
- 4) If the call is not successful, a cause message will be displayed on the LCD. For more information, the "**Status**" menu can be accessed to view the **CAUSE INFO**, which will give a diagnostic cause message.
- 5) If set-up needs to be checked, press the "**Setup**" keypad button, which will prompt the operator to answer several setup related questions that will configure the Model 550B to the circuit and switch being accessed.
- 6) If the upper LCD status line doesn't indicate "READY FOR CALL" when the "Hook On/Off" button is pressed, the X.25 link hasn't been made.
- 7) If the LCD top status line doesn't indicate "D-PACKET CONNECTED" when the "#/Utility" keypad button is pressed to send the call, the call was not successful.

Introduction

1.2.4 CABLES AND ACCESSORIES

The Model 550B ISDN Portable Test Set comes equipped with the following cables and accessories:

<u>PART #</u>	<u>DESCRIPTION</u>
TPI 550B-1A (TPI 835835)	8-Pin Mod to 6-Pin Mod Cable
TPI 550B-2 (TPI 834005)	8-Pin Mod to 8-Pin Mod Cable
TPI 550B-3L (TPI 836175)	8-Pin Mod to 2-Alligator Clips Cable
TPI 550B-4 (TPI 851555)	Battery Charger/AC Adapter [12VDC, 500mA] ("POWER/CHARGE" Jack)
TPI 550B-22	National Call Control

The Model 550B ISDN Portable Test Set has several optional features and accessories which may be ordered as well:

<u>PART #</u>	<u>DESCRIPTION</u>
TPI 550B-3 (TPI 834008)	8-Pin Mod to 4-Clip Leads Cable (HD)
TPI 550B-6 (TPI 834045)	8-Pin Mod to Heat Coil Connector Cable
TPI 550B-7 (TPI 837191)	Soft Pack Carry Case
TPI 550B-8 (TPI 835090)	Hand Set (Telephone w/Cord & 4-Pin modular plug to make a voice call.) Plugs into "HAND SET" connector on front panel.

Introduction

Cables and Accessories

TPI 550B-15	2B1Q Interface
TPI 550B-16	Data Capability (For monitoring of "D" channel packets, setup of Circuit Switched Data Calls, setup of Packet Data Calls, and Bit Error Testing.)
TPI 550B-17 (TPI 835075)	8-Pin Modular to Bantam Cable
TPI 550B-18 (TPI 835080)	8-Pin Modular to Twin Bantams
TPI 550B-19 (TPI 835085)	Craft Access Adapter
TPI 550B-23 (TPI 835038)	EBS/POTS Interface
TPI 550B-24	DB9 to DB9 Cable (Turnover)
TPI 550B-27	B-Packet Capability - Future
TPI 550B-HVT (TPI 835094)	High Voltage Termination Module

Introduction

1.3 MAINTENANCE

The only replaceable parts on the ISDN Portable Test Set are the firmware module (bottom of unit) and external cords. The LED indicators and displays are soldered into the unit and are not field replaceable.

If the Model 550B operation should become suspect, the unit may be checked for proper operation by performing a SELF TEST. This is done by turning the power off then on again, which will initiate a Power-Up Self Test. If this procedure does not operate successfully, contact the factory Customer Service department at 540-375-0500.

1.3.1 CALIBRATION

Calibration is not required for the Model 550B, due to the Digital nature of its design, and due to the synchronous nature of the derived timing from the network. If proper operation of the ISDN Portable Test Set is in question, the Power-Up Self Test mentioned above may be performed.

1.3.2 EPROM MODULE

The Model 550B houses a removable firmware EPROM module, located on the bottom of the unit. This module can be upgraded in the field. Replacement is accomplished through the following steps:

1. Turn the power off and unplug the AC Adapter, if used.
2. Close the lid to the Model 550B
3. Turn the Model 550B over, resting on the lid.

Introduction

4. With a static discharge wrist strap on, remove the (4) screws from the EPROM door on the bottom of the unit.
5. Remove the door.
6. Gently pull out the firmware EPROM circuit board with the pull tab.
7. Insert the new board assembly as shown below:

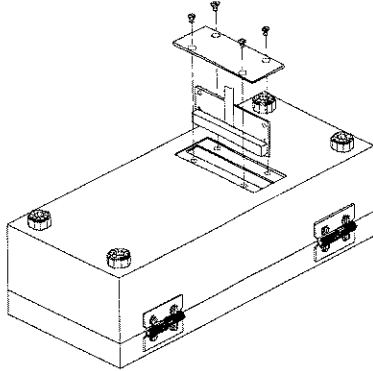

8. Replace the (4) screws in the EPROM door.
9. Depress and hold the **"*/Store"** key when powering up the Model 550B until the LCD screen reports "RESTORE SYSTEM DEFAULTS" then verify that the SELF TEST passes.
10. Return the replaced EPROM module(s) to TPI Customer Service, with the unit serial number noted.

Introduction

1.4 SPECIFICATIONS

PHYSICAL

LINE INTERFACES (Optional)

- 2B1Q - per ANSI T1.601 (1988)
- AT&T AMI - per AT&T 5D5-900-311
- EBS (P-Phone) - per Bellcore TR 73505
- POTS - per Bellcore TR-TSY-000344

S/T INTERFACE (Standard) - per ANSI T1.605
(1989)

POWER

- Internal NiCad Rechargeable Battery
- Battery Charger/AC Adapter
- Battery Recharge Time = 12 to 14 hours

WEIGHT

2½ pounds

DIMENSIONS

2" deep, 4¼" wide, 9½" long

OPERATING TEMPERATURE RANGE

0°C to +50°C

DATA ACCESS

- DB-9 pin connector RS-232: 9600 Baud, 8 Data Bits, No Parity, 1 Stop Bit.
- Use "Null" or "Turnover" cable.

HANDSET

The HANDSET jack is compatible with the optional TPI handset, part number 550B-8 (TPI 835090). Other handsets may have incompatible microphone elements.

Introduction

OPERATIONAL

MODES

- TE (Phone Replacement)
- NT1 (NT1 Replacement)
- NT1/TE (Phone and NT1 Replacement)

CALL CONTROLS

- 5ESS per AT&T 5D5-900-321
- NTI-S and NTI-F per NT NIS-S208
- NAT'L per Bellcore Documents for NI-1, NI-2, & NI-3

ATTENUATION:

- LINE = 0-15dB, 1dB Steps
- S/T = 0-7dB, 1dB Steps
- 22 AWG Cable Simulators

WARRANTY

- 1 year

TECHNICAL SUPPORT

- Factory technical support is available at 540-375-0500 and local field sales support is available across the United States.

Introduction



MEASUREMENTS/INDICATORS

LCD

4 x 20 Graphics Display

TEST RESULTS

2B1Q

CRC Errors & Errored Seconds
FEBE Errors & Errored Seconds

ATT AMI

FRAME Errors & Errored Seconds
FEBE Errors & Errored Seconds

S/T

FRAME Errors & Errored Seconds
BPV Errors & Errored Seconds

P-PHONE (EBS) MEASUREMENTS

8KHz Carrier / Secondary Channel

Signal Level Range < -22 dB
 $+ 2$ dB

Line Voltage $< 5V$
 $> 65V$

Resistance displayed in approximate
ranges of: $> 1K \Omega$
approx. $1K \Omega$
approx. 700Ω
approx. 400Ω
approx. 200Ω
approx. 100Ω
 $< 100 \Omega$

CALL STATUS

Displayed on LCD

TEST INTERVAL

1 Minute to 99 Hours

Introduction

LED INDICATORS**STATUS**

- SYNC** - Indicates DSL is Framed
(Framing Pattern)
- ACTIVE** - Indicates DSL is Activated
(Act bit is set to network)
- ERROR** - Indicates that Error has been detected on DSL
 - 2B1Q - CRC OR FEBE
 - ATT AMI - FRAME Error or FEBE

- OFF HOOK** - Indicates that the Model 550B is in a call state

- SEALING CURRENT** - Indicates that Sealing Current is present on the DSL
 - (2B1Q - GREEN indicates Sealing Current)
 - (AT&T AMI - GREEN indicates Correct Polarity)

- S/T INTERFACE** - PS1 - Indicates that Power Source 1 is present and over 30 volts (GREEN indicates Correct Polarity / RED indicates Reversed Polarity)
 - PS2 - Indicates that Power Source 2 is present and over 30 volts (GREEN indicates Correct Polarity / RED indicates Reversed Polarity)

- BATT. LOW** - Indicates a Battery Low condition, with a maximum of ten minutes of operating time remaining before complete shutdown

Introduction

TPI Model 550B ISDN Basic Rate Test Set
 TELE-PATH INDUSTRIES

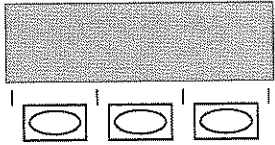
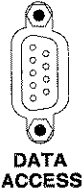
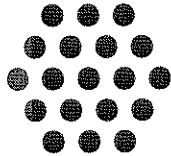

Status QZ 1	Auto ABC 2	BERT DEF 3	Hook On/Off
GHI 4	JKL 5	MNO 6	Scroll Menu
PRS 7	TUV 8	WXY 9	Setup
* Store	OPER 0	# Utility	2 nd Func.

Off Hook

- STATUS**
- 2B1Q
 - AMI
 - EBS
 - POTS
 - Sync
 - Active
 - Ready
 - Error

2 WIRE LINE

- Sealing
- Current

4 WIRE S/T

ON Charging

OFF Batt. Low

Term 100Ω

PS1 PS2

50Ω

HAND SET



2.1 POWER UP

Press the power "ON" switch. This will turn the ISDN Portable Test Set on, and will start the five second Self Test routine. The LCD screen will flash (with all pixels turned on), then clear, and all LED's will light, then extinguish.

When the self test has concluded, a message will appear on the LCD screen (briefly) with the current software version and a message reporting the results of the Self Test. A "N" after the firmware version indicates that the "National ISDN Call Control" option has been installed.

At the conclusion of the Self Test routine, the LCD will report the last setup used. For example, the following menu would result at the conclusion of the Self Test routine if the last setup application was ISDN, the mode was NT1/TE, the call control was 2B1Q, the switch was 5ESS, and a Point-to-Point line was used:



This power up menu prompts the user to consider the setup for the current application, prior to taking any other action. Should this last setup need to be changed, press the "CHANGE" soft key and the **EASY-USER-MODE** will walk the user through the entire setup routine.

If the last setup reported is correct, the setup may be accepted, or other menus may be selected:

- 1) Pressing the "**2/Auto**" key will enter the U INTERFACE AUTO CONFIGURATION menu.
- 2) Pressing any other key will result in access to the menu indicated.

The "**STATUS**" LED's will report the last interface used (provided that the "S/T" Interface was not the last interface used).

The "**STATUS Error**" LED will illuminate for the selected interface until access is gained to a circuit.

NOTE: *If the power up self test should fail, please contact TELE-PATH INSTRUMENTS at 221 S. Yorkshire St., Salem, VA 24153, phone (540) 375-0500, fax (540) 375-0505.*

Operation

2.2 SETUP

When the unit is first turned on, it will conduct the Power On Self Test, and the following message will be momentarily displayed:



Upon successful completion of the Power On Self Test another message will be momentarily displayed, stating that the test has been passed.

The unit will then proceed to display the following configuration menu:



Please note that the contents of this screen will vary according to the unit's previous setup.

Press the appropriate soft key to either accept the setup shown, or enter a new setup.

Pressing the **"CHANGE"** soft key will result in the following "Present Setup" screen:

```

** PRESENT SETUP **
ISDN NT1TE 2B1Q 5ESS
PP
ISDN
  
```

SERVICE MODE:

This menu is for selection of a service mode, which will include POTS and EBS (P-Phone) if optioned. After a service mode has been selected, or the **"Scroll Menu"** keypad button has been pressed, the following menu will result:

```

** PRESENT SETUP **
ISDN NT1TE 2B1Q 5ESS
PP
NT1 TE NT1TE
  
```

MODE OF OPERATION:

If you wish to use this unit connected in place of the NT1, select the **"NT1"** soft key. If you wish to use this unit connected in place of the TE, select the **"TE"** soft key. If you wish to use this unit connected in place of both the NT1 and the TE, select the **"NT1TE"** soft key.

If you wish to use this unit connected in place of the Line Terminating device, under the **"Utility"** menu, **"CONFIG"** sub-menu, select the **"LTMODE"** soft key.

Operation

The following menu will then appear:

```
** PRESENT SETUP **
ISDN NT1TE 2B1Q 5ESS
PP
2B1Q AMI
```

INTERFACE:

Please note that the bottom line of this display will show your previous selection, and may not be as shown in this illustration.

After an Interface has been selected, or the "Scroll Menu" keypad button has been pressed, the following menu will result:

```
** PRESENT SETUP **
ISDN NT1TE 2B1Q 5ESS
PP
5ESS DMSF NAT'L
```

CALL CONTROL:

Please select the current call control. The choices are: 5ESS, DMS-Functional, and optional NAT'L (Includes NI-1, NI-2, and NI-3 support).

NOTE: *The seldom used Northern Stimulus call control may be selected in the "Call Control" "Utility" sub-menu.*

Other menus will then proceed to ask for information relevant to your particular setup. The information needed to complete the setup will depend on what menu selections you have made up to this point. This may include whether the circuit is point-to-point or multi-point, the SPID, DN (Directory Number), and TEI, (0-63).

Operation

CONFIGURATION:

For example, pressing the "5ESS" soft key will display:

```

** PRESENT SETUP **
Config is PT to PT
PTTOPT  MULTPT
  
```

Selection of "MULTPT" will display:

```

** PRESENT SETUP **
Enter SPID
BACKSP  SEND
  
```

Enter the new SPID (Service Profile Identifier) using the keypad keys. Pressing "SEND" will show the present setup display with "MP" for multi-point. (No SPID is required in a PT to PT circuit configuration for 5ESS custom.)

NOTE: *If the "Second Call" feature is ON, two SPID's must be entered. If the setup is "5ESS, Pt-to-Pt, and Data call" only one SPID is required.*

If entry of the TID is required, it should be entered as two digits on the end of the SPID.

Pressing "ENTER" will display to the following menu:

```

ENTER
DIRECTORY NUMBER
DN: NONE
NONE  BACKSP  ENTER
  
```

The Directory Number (sometimes called Primary Directory Number) is required for non-CACH translations. The DN is normally seven digits and is automatically populated from the SPID, but may be changed via this menu.

Operation

Pressing "ENTER" or "Scroll Menu" moves to the TEI screen:

```
** PRESENT SETUP **
TEI IS AUTO 127
AUTO  FIXED
```

The Terminal Endpoint Identifier (TEI) identifies the layer 2 entity that is communicating with the switch on a multi-point circuit. The "AUTO" setting is the normal and default condition allowing the switch to assign the TEI for each communication session. For certain older CPE, a fixed number exists in hardware. The test set can emulate this condition by setting a fixed number from 0-63.

When you have entered all of the necessary information, the "ACCEPT / CHANGE" screen will again be shown.

```
** PRESENT SETUP **
ISDN NT1TE 2B1Q 5ESS
PP
ACCEPT  CHANGE
```

After accepting the new setup, you will proceed to the "ON HOOK" screen, which is the default screen:

```
IDLE          XXXX
ON HOOK
REDIAL  SPEED  SPID
```

From this screen, you can also access Last Number Redialing, Speed Dialing, and entry of the SPID.

NOTE: *If the "Second Call" feature is ON, the "Hook" screen will show "PH #1" or "PH #2" in the upper right-hand corner. Pressing the "Scroll Menu" key moves the display back and forth between the two calls.*

If, at any time, you wish to change the unit's setup, press the "Setup" key. You will then return to this set of menus.

Operation

2.3 PRE-QUALIFYING CABLE PAIRS

Pre-qualification of cable pairs is becoming more popular, so that cable construction people can have confidence that the copper plant will handle the service being planned for deployment, prior to the Central Office and Customer Premise equipment being connected.

The Model 550B can be used at the Customer Premise in conjunction with another Model 550B at the Central Office to pre-qualify a Basic Rate Interface (BRI) cable pair.

The following procedures are recommended for pre-qualification:

- 1) Gain access to the cable pair under test using the **LINE INTERFACE** jack on both units.
- 2) Setup the Model 550B's for the line under test.
 - The Customer Premise 550B should be in NT1TE mode.
 - The Central Office 550B should be in **LT mode**.
 - The "Sync" and "Active" LED's should light.

NOTE: *The "Sealing Current" LED will not be lit, nor will the "Ready" LED be lit on either 550B. No calls can be placed, but the line can be qualified by testing B1 and B2, and checking for CRC and FEBE errors.*

- 3) B1 and B2 can be tested by performing a BER test in either a straightaway fashion, or by using the Central Office 550B to configure a loopback in the Customer Premise 550B and BERT to that loopback.

Operation

LOOPBACK FROM THE CENTRAL OFFICE:

- 1) On the Central Office 550B, press the "Utility" key, then the "CONFIG" soft key.
- 2) Press "Scroll Menu" until the 2B1Q U INTERFACE menu is displayed.
- 3) Press the "LTMODE" soft key to select "Line Termination" mode.
- 4) Press the "MESSAG" soft key until 2B+D LOOPBACK is displayed. Press the "SEND" soft key.
- 5) Press the "2nd Func." key then the "BERT" key.
- 6) Press the "Scroll Menu" key then the "B1" soft key.
- 7) Press the "Scroll Menu" key then the "64K" soft key.
- 8) Testing will begin when you press the "STRCLR" soft key.
- 9) Press the "STRCLR" soft key again to clear any errors. The Bit Errors (BE) and Errored Seconds (ES) should stop counting.
- 10) Run the test for the desired turn-up time and monitor results for acceptable error performance.
- 11) Testing will terminate when you press the "STOP" soft key.

Testing B2 may be performed in a similar fashion.

NOTE: *When sending an EOC channel command, e.g., B1 Loopback, the NT1 is always address 0 (default setting). A mid-span repeater, address 1, may also be controlled for loopbacks.*

Operation

REPEATERED LINE:

For a line with a 2B1Q Repeater, the repeater must be powered in order for the whole loop to be tested. The Model 47 Line Power Module may be used for this purpose. The diagram below shows the connections when using the Model 47.

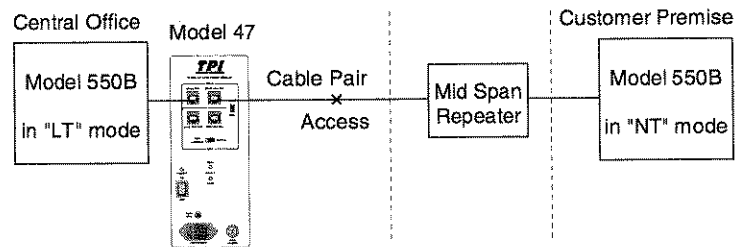

The switches on the Model 47 should be set to **2B1Q** and **Normal**. Connect the Model 47 **Model 546** jack to the **LINE INTERFACE** jack on the Central Office 550B. The **2B1Q Line Out** jack connects to the line under test.

Once the connections are made, the Model 47 will power the repeater and testing between the Model 550B's can proceed, as described earlier.

40KHz TEST TONE:

The Model 550B can generate a 40KHz test tone which is the Nyquist frequency for the 2B1Q signal. The signal is launched at 0dB. A TIMS set at the far end measuring the tone level can thus measure loop loss.

Operation

2.4 TESTING AT THE "U" INTERFACE

- 2.4.1** Setup = Use "**Setup**" key for
EASY-USER-MODE
[Service Mode = ISDN]
[ISDN Mode = NT1/TE]
[Interface = 2B1Q or ATT]
[Call Control = 5ESS, DMS-F, or
NAT'L]
- 2.4.2** Connection = Use **LINE Interface** Jack
- 2.4.3** Place A Call = Use "**Hook On/Off**" key
- 2.4.4** Errored Second Testing = Use "**1/Status**" key
- 2.4.5** Network Originated Loopback Testing = **STATUS** LED's will indicate
Loopback status
- 2.4.6** BERT TESTING = Use "**3/BERT**" KEY

Model 550B

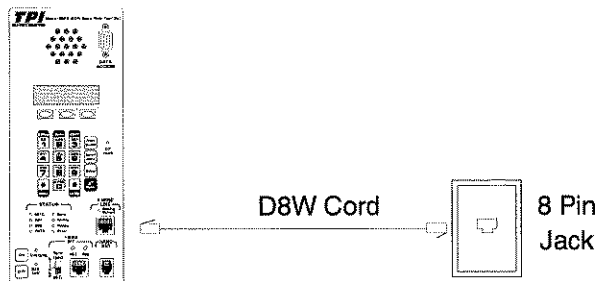

Replacing an "NT1" and "TE" with the Model 550B.

Operation

Testing at the "S/T" Interface

2.5 TESTING AT THE "S/T" INTERFACE

2.5.1 Setup = Use **"Setup"** key for EASY-USER-MODE
 [Service Mode = ISDN]
 [ISDN Mode = TE]
 [Interface = 5ESS, DMS-F, or NAT'L]

2.5.2 Connection = Use **S/T INTERFACE** Jack

2.5.3 Place A Call = Use **"Hook On/Off"** key

2.5.4 Errored Second Testing = Use **"1/Status"** key

2.5.5 Network Originated Loopback Testing = **STATUS** LED's will indicate Loopback status

2.5.6 BERT TESTING = Use **"3/BERT"** KEY

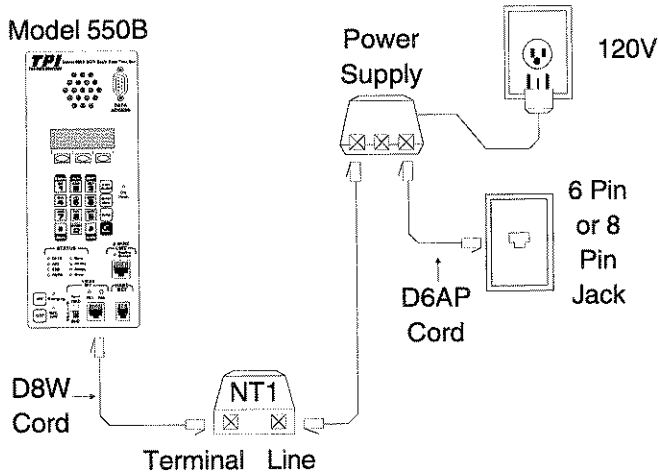

Replacing a "TE" with the Model 550B

Operation

2.6 DUAL CALL CAPABILITY

2.6.1 OVERVIEW

The Dual Call feature for the Model 550B allows two Circuit Switched Data calls to be in progress at the same time - two outgoing, two incoming, or one of each. This verifies that both "B" channels can be used simultaneously.

Although it will work for Voice in most cases, the Dual Call feature is intended for simultaneous Data calls. This simulates what happens when a Video Terminal Adapter sets up a call on each B-Channel and combines the bandwidth, in order to transfer Video information at 112 Kbps or 128 Kbps.

NOTE: *For 5ESS custom and National call controls with point-to-point service, dual Voice calls are not allowed.*

The Dual Call feature was designed as an enhancement for the 550B-16 Data Capability option, and can be provided as a Firmware Upgrade for the Model 550B ISDN Portable Test Set. EPROM Firmware modules can be mailed, on request to holders of Model 550B's that were purchased with the 550B-16 Data Capability option.

2.6.2 DETAILS

1) Setup

- Set up the Model 550B as normally done prior to connecting to the line under test (e.g., SPID, Call Control, etc.).
- Connect the Line-under-test , and wait for "**Sync**", "**Active**", and "**Ready**" indications as you would for a normal setup.

Operation

- Choose the "Utility" key, then the "MODES" soft key.
- Press the "Scroll Menu" key for the SECOND CALL menu.
- Press the "ON" soft key to enable the second call mode.

NOTE: *If the Line-under-test is 5ESS Point-to-Point (single SPID or no SPID), press the "Scroll Menu" key again to access the Dual TEI Mode menu. (Press the "OFF" soft key to disable Dual TEI Mode)*

- Press the "EXIT" soft key to return to the PH #1 HOOK screen.

2) SPID

- Press the "SPID" soft key to verify SPID #1 is correct. If correct, press the "Scroll Menu" key to enter SPID #2 (not needed for 5ESS Point-to-Point)
- Press the "EXIT" soft key to return to the HOOK menu.

3) SPEED

- Press the "Utility" soft key, then the "DATA" soft key to access the BEARER CAP menu.
- Select the "DATA" soft key, then press the "Scroll Menu" key to set the Speed to 64K, if desired.
- Press the "Scroll Menu" key again, then the "EXIT" soft key to return to the HOOK screen.

Operation



4) OPERATION

- When the Dual Call Mode has been enabled, "PH #1" will appear in the upper right corner of the HOOK screen.
- Press the "**Scroll Menu**" key and "PH #2" will appear. (In this manner, the screen and keypad are coordinated to operate as two phones.)
- Calls may now be placed or received on either or both B-Channels using the Second Call mode. All call control menus are still valid. (e.g., Call Appearance, B-Channel selection, and Bearer capability for each "Phone")

NOTE: *The first time "**Scroll Menu**" is used to access the "PH #2" Hook screen, the Model 550 will request a 2nd TEI from the CO (if Dual TEI mode is enabled), and initialize with the second SPID. This may require 20 to 30 seconds to take place, and going OFF HOOK before this time on "PH #2" will only cause confusion.*

5) TYPICAL TEST SCENARIO

Initiate a Call on "PH #1"

- Go OFF HOOK on "PH #1"
make sure that the message "Dial tone" appears on the Hook Screen (on 5ESS Switches, no Dial tone will be heard).

Initiate a Call on "PH #2"

- Depress "**Scroll Menu**" to select "PH #2".
- Go OFF HOOK on "PH #2"
- If the "Dial Tone" message appears on the Hook Screen, the translations are correct (max B-Channel) for Simultaneous Data calls

Operation

Clear the calls

- Go back ON HOOK for "PH #2"
- Depress "**Scroll Menu**" to select "PH #1"
- Go ON HOOK.
- The above Scenario is all that is necessary to test for Simultaneous B-Channel operation.

6) ADDITIONAL TEST SCENARIO

- Place a call from one B-channel to another, place one in loopback and initiate BERT from the other call (B-channel).

The dual call feature of the Model 550B enables BER tests to be conducted on both B-channels simultaneously, thus testing the full 128K bandwidth. This testing can be accomplished in two scenarios.

LOOPBACK:

- With each B-channel having a dialable number, turn the "Second Call" feature ON in the "Utility" menus, "EXIT" to the ON HOOK screen, select "SPID" soft key, and enter SPID #1 and SPID #2. Return to the Hook screen for PH#1 (Phone 1) and press "**Scroll Menu**" to reach the PH #2 Hook screen. Wait approx. 15 sec for Phone #2 to initialize with the switch. Go Off Hook and dial the number for phone #1.

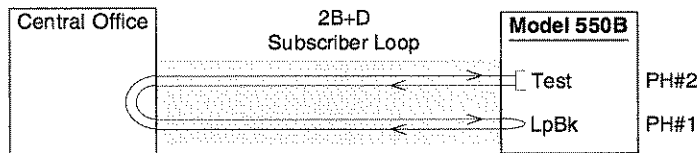

Operation

- When the sonalert is heard, press "**Scroll Menu**" to move to Phone #1, press the "**Hook On/Off**" key to answer the call. Place one of the B-channels into loopback mode (**2nd Func.**, **Utility** key, **CONFIG** soft key, **Scroll** to Loopback menu), enter the BERT menu (**2nd Func.**, **BERT**), and start a test over the other B-channel.

STRAIGHTAWAY:

- In the same manner as above, two technicians with Model 550B's can call each other. In this scenario, the first would call the second technician. The second technician would then call the first, using the PH#2 Hook screen. The called technician would place the incoming B-channel in loopback. Each technician would then initiate BER testing over the out-bound B-channel.



Operation

2.7 P-PHONE (EBS) TESTING

Electronic Business Set (EBS), or P-Phone, is a service provided by Northern Telecom DMS or SL switches. The service provides a user with Centrex-like features that aren't normally available on a conventional POTS line.

EBS service is provided through a non-loaded subscriber loop pair that carries conventional voice traffic and a secondary above voiceband signaling channel. In addition to Off Hook/On Hook and Dialing information, this secondary channel carries Line Status, Number ID, and Display information.

There may be several devices connected to an EBS line at the customer premise. Each device would have its own address in order to communicate with the switch. There is always a basic set with address "0" that terminates the line, normally at 900Ω. Add-on devices may include speaker phones or 18-button, 20-button, or 36-button add-on modules. The Model 550B can be configured for any address (0-7) and any button number (1-254). The Primary telephone always uses address 0. Expansion units associated with the Primary telephone use addresses 1, 2, or 3. The Extension telephone always uses address 4. Expansion units associated with the Extension telephone use addresses 5, 6, or 7.

If "EBS" is selected during setup, the following menu will be displayed:

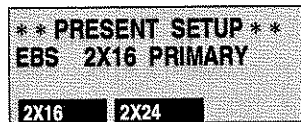

This screen allows a selection of the display size which is to be emulated.

Operation



Pressing "**Scroll Menu**" moves to the following screen:

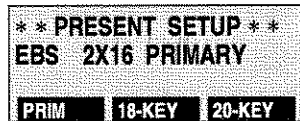

This screen enables a selection for "Primary Set" or an 18-key or 20-key add-on unit emulation. Upon selection, the display moves to the "Station Address" selection:

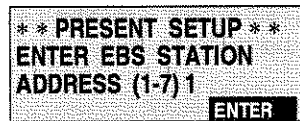

As outlined earlier, the primary set is always address "0", Add-On units for the primary set are "1, 2," or "3", the Extension Set address is "4" and the Add-On units for the extension set are address "5, 6," or "7". After entering the station address, press "**ENTER**". Pressing "**Scroll Menu**" will return to the "Present Setup" menu.

Press the "**ACCEPT**" soft key and make the selections for the present setup. The "Hook" screen will be displayed:



Press the "**Hook On/Off**" key to answer an inbound call or to place an out-going call. Pressing the "**FEATUR**" soft key changes the soft key selections to: "HOLD, RELEAS," and "SEND". The "**HOLD**" and "**RELEAS**" keys emulate the same keys on the CPE (telephone). The "**SEND**" key is used to activate a feature key number and press "**SEND**" to activate that feature key.

Operation

To verify P-Phone/EBS Service:

1) Configure the Model 550B for EBS/P-Phone

- Use the "**SETUP**" key to gain access to the EASY-USER-MODE Menu
 - If "EBS" is displayed on line 2 of the LCD, press the "**ACCEPT**" soft key
 - If anything else is displayed on Line 2 of the LCD, press the "**CHANGE**" soft key.
 - Select the "**EBS**" soft key
 - Select Display Size (2x16, 2x24)
 - Select Device (Primary, 18-key, 20-key)
 - Select Station Address (0-7)
 - Select the "**ACCEPT**" soft key.
- After a short recalibration period, the LCD will display the "ON HOOK" menu.

2) Verify the Line Connection

- Use the LINE Jack for connection to the EBS/P-Phone network.
 - Once connected :

"Ready" LED indicates that communication is setup with the switch.

Voltage & Current presence is indicated when the "Sealing Current" LED is lit.

Polarity is indicated on the LCD display in the upper right hand corner:

"None" = Not enough Voltage or Current
"Norm" = Tip is Ground, Ring is Battery
"Rev" = Tip and Ring are reversed

Operation

- 3) A Voice Call may now be placed using the "HOOK ON/OFF" key
- By going "OFF HOOK", the Model 550B will send an "OFF HOOK" Message on Key #1 for address "0". Dial Tone should be heard, and a call can then be placed. If a call comes into the Model 550B, "RINGING" will be displayed on the LCD Screen, and the sonalert will sound. In order to answer an incoming call, go "OFF HOOK". "Display Data" received from the switch will also appear on the LCD. Conversation can then take place. To end a call, go "ON HOOK".
 - The Key or Button Number may also be selected for incoming or outgoing calls by selecting the "**FEATUR**" soft key. For example, by pressing "**3**" and the "**SEND**" soft key on the Hook Menu, the Model 550B will send an OFF HOOK message on Key "3" for address "0".
 - The Address the Model 550B sends can also be changed via the "**Utility**" menu and "**MODES**" soft key, and "**Scroll Menu**" to the "EBS STATION ADDRESS" menu. For example, pressing the desired Address Number then the "**ENTER**" soft key, the next message sent to the switch will have the new Address.

Operation

- 4) P-Phone line measurements are available by pressing the "1/Status" key and the following menu will display:

```
SIGNAL LEVEL XXXX dB
LINE VOLTAGE XXXX V
RESISTANCE XXXX Ω
EXIT TEST
```

The signal level displayed is the actual measured loss of the cable plant as if the 8 KHz signal were sent at 0dBm like a TIMS box would. To take another measurement, press the "TEST" soft key.

- 5) Access messages decoded (in English) from switch communications by pressing the "#/Utility" key, "DATA" soft key, and "Scroll Menu" to display the following screen:

```
DISPLAY EBS DECODE
0012 MESSAGES
012 MESSAGES HELD
LCD SERIAL CLEAR
```

In the above example, the digits "0012" show that there are a total of 12 EBS messages that have occurred and 12 stored EBS messages in the EBS message buffer.

The EBS message buffer has the capability to store up to 128 message decodes. The fourth line of the LCD allows selection of displaying an abbreviated message on the LCD, outputting the detailed message decodes in real time (as they occur) via the "DATA ACCESS" connector ("SERIAL" soft key), or Clearing the message buffer by simply pressing the corresponding soft key.

The following is an example of an abbreviated message decode if the LCD is selected for output:

```
025 No Pack
026 CPE>CO 1D-HKS On
027 No Pack
UP DOWN RETURN
```

Operation

The number "026" represents the sequential message decode number. The "CPE>CO" provides information concerning the direction, in this example the direction is from "CPE" towards the "CO". The next displayed item "1D" is the hexadecimal representation of the message. "HKS On" is an abbreviated message decode stating that the Hook Switch is On Hook. Pressing the "UP" or "DOWN" soft key, will scroll through the messages. The "RETURN" soft key will step back to the "DISPLAY EBS DECODE" display.

Some of the abbreviations with explanations are in the table below:

<u>ABBREVIATION</u>	<u>MESSAGE</u>
IndxOFF	Indicator x (1-9) OFF
Ind0OFF	Indicator 10 OFF
IndxWNK	Indicator x (1-9) WINK
Ind0WNK	Indicator 10 WINK
IndxFLH	Indicator x (1-9) FLASH
Ind0FLH	Indicator 10 FLASH
Ind xON	Indicator x (1-9) ON
Ind10ON	Indicator 10 ON
HardRst	Hard Reset
SoftRst	Soft Reset
PwrDown	Power Down Reset
ClsEcho	Close Echo
OpnEcho	Open Echo
AlrtOff	Alert-Off
AlrtOn	Alert-On
VoicOff	Voice-Off
VoiceOn	Voice-On
HSetOff	Handset-Off
HSetOn	Handset-On
BuzzOff	Buzzer-Off
BuzzOn	Buzzer-On
AABkOff	Auto Answer Back-Off
AABkOn	Auto Answer Back-On

Operation

For further explanations of specific messages, please refer to BELLCORE document TR73505, Issue B, Section 5.

Pressing the "**SERIAL**" soft key from the DISPLAY EBS DECODE menu will immediately send output of all the stored messages to the "DATA ACCESS" connector on the front panel. A terminal or printer (Serial) may be attached to the Data Access connector to "Print" the information out. The messages printed out are not abbreviated and have more detail than the LCD information. An example of the output when "**SERIAL**" is pressed follows:

```
0026 Direction.. CPE->CO Time 12:07:34.2
      Address.... 0
      command.... 1D Hookswitch On-Hook
```

```
0028 Direction.. CO->CPE Time 12:07:35.1
      Address.... 0
      Command.... 60 Indicator 1 ON
      Repeat..... No
      Collision.. No
      Parity..... Passed
      Hex: C302
```

NOTE: *The DB9 data access ground is not isolated from the EBS line. Therefore you cannot do real time monitoring on the line unless there is no ground connection, i.e., a laptop computer running on battery power with a terminal emulation program.*

Operation

To summarize, an EBS line may be tested by:

- 1) Verifying the Voltage & Current - Sealing Current LED
- 2) Verifying the Polarity - LCD Screen (Upper right hand corner)
- 3) Placing a Call from the Model 550B to a Test Number
- 4) Receiving a Call with the Model 550B
- 5) Measuring signal level (8KHz Carrier/Secondary Channel), line voltage, and resistance

Additionally, the Model 550B may be used to change the Address and Call Appearance to activate other desired Buttons.

NOTE: *If the EBS/P-Phone optional interface (550B-23 EBS/POTS Interfaces) has not been ordered, "EBS" will not show on line 2 of the LCD as a Line Interface choice.*

EBS/P-Phone Testing

- 2.7.1 Setup = Use "**Setup**" key for **EASY-USER-MODE**
[Service Mode = EBS]
- 2.7.2 Connection = Use **LINE INTERFACE** Jack
- 2.7.3 Place A Call = Use "**Hook On/Off**" key

Operation

2.8 POTS TESTING

To verify POTS Service:

- 1) Configure the Model 550B for POTS
 - Use the "**Setup**" key to gain access to the EASY-USER-MODE Menu
 - If "POTS" is displayed on line 2 of the LCD, press the "ACCEPT" soft key
 - If anything else is displayed on Line 2 of the LCD, press the "**CHANGE**" soft key. Select "POTS" by pressing the "**POTS**" soft key, then the "**ACCEPT**" soft key.
 - After a short recalibration period, the LCD will display the "ON HOOK" menu:



- From the "ON HOOK" menu, pressing the "**MON**" soft key will allow unintrusive monitoring of the POTS line
- 2) Verify the Line Connection
 - Use the LINE Jack for connection to the POTS network.
 - Once connected :

Voltage & Current presence is indicated when the "**Sealing Current**" LED is lit.

Polarity is indicated on the LCD display in the upper right hand corner:

"None" = Not enough Voltage or Current
 "Norm" = Tip is Ground, Ring is Battery
 "Rev" = Tip and Ring are reversed

Operation

- 3) A Voice Call may now be placed using the "Hook On/Off" Key

To summarize, a POTS line may be tested by:

- 1) Verifying the Voltage & Current - Sealing Current LED
- 2) Verifying the Polarity - LCD Screen (Upper right hand corner)
- 3) Placing a Call from the Model 550B to a Test Number
- 4) Receiving a Call with the Model 550B

NOTE: *If the POTS optional interface (550B-23 EBS/POTS Interfaces) has not been ordered, "POTS" will not show on line 2 of the LCD as a Line Interface choice.*

POTS Testing

2.8.1 Setup = Use "**Setup**" key for EASY-USER-MODE [Service Mode = POTS]

2.8.2 Connection = Use **LINE INTERFACE** Jack

2.8.3 Place A Call = Use "Hook On/Off" key

NOTE: *If available as a service, Incoming call Line ID (date, time, and number) will be displayed on the second ring.*

Operation

2.9 NT1 REPLACEMENT

- 2.9.1** Setup = Use "**Setup**" key for **EASY-USER-MODE**
[Service Mode = ISDN]
[ISDN Mode = NT1]
[Interface = 2B1Q or ATT]
- 2.9.2** Connection = Use **LINE INTERFACE** Jack
- 2.9.3** Errored Second Testing = Use "**1/Status**" key
- 2.9.4** Network Originated Loopback Testing = **STATUS** LED's will indicate Loopback status

NOTE: *The Model 550B will pass power from the "U" Interface jack to the "S/T" Interface jack. If a phone were connected to the "S/T" Interface jack, the phone must be powered by a separate power supply.*

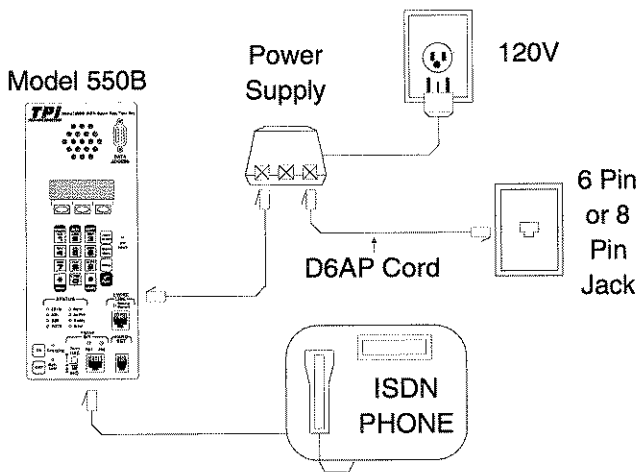

Replacing an "NT1" with the Model 550B.

Operation

2.10 MONITOR D-CHANNEL PACKETS (Option)

2.10.1 Monitoring of received "D" channel packets with remote equipment is optionally available, via the DB-9/RS-232 connector on the front panel labeled "DATA ACCESS". Enable the "D-Channel Monitor" through the "Utility" menus. Information displayed will be in the HEX format and English language.

2.10.2 The communication parameters for the Model 550B are factory pre-set. Consequently, the remote equipment parameters will need to be set to match those of the Model 550B. These are 9600 Baud, No Parity, 8 Data Bits, 1 Stop Bit.

2.10.3 When connecting the equipment directly to the Model 550B, a null-modem cable may need to be used depending on the equipment and connector used. This type of cable has pins 2 and 3 reversed.

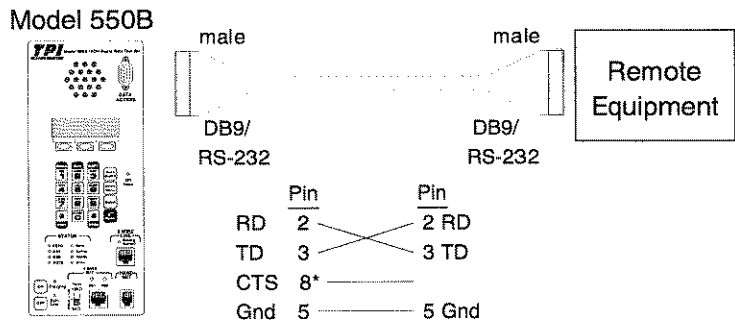

NOTE: * Pin 8 (CTS) on Model 550B is used for data transfer flow control. This may be needed for slow devices (i.e., printers). If enabled from Model 550B "Utility" menu (Flow Control = On), the Model 550B will not transfer data unless pin 8 is enabled.

Operation

D-Channel Output Example

Output example:

```

TE->NT:C SAPI:000 TEI:104 Time00:01:36.9
I Ns=003 Nr=003 P/F=0
PD=08.....Call Reference:001
M 05 SETUP
I 04 BEARER_CAPABILITY.....Len= 3
 80 Coding Standard.....CCITT
  Transfer Capa.....Speech
 90 Transfer Mode.....Circuit
  Transfer Rate.....64 kbit/s
A2 Layer 1 Protocol.....u-law
I 18 CHANNEL ID.....Len= 1
 8B Indicated Channel....Exclusive
  Channel Selection.....Any
  Channel Identifier.....Not D-CH
I 24 TERMINAL CAP.....Len= 1
 02 Coding Standard.....Any
  Capability.....Type 2 stimulus
I 36 SWITCHHOOK.....Len= 1
 01 Off-hook
I 96 Shift          Locking Codeset=6
I 23 ORIG CALL APPEAR.....Len= 1
 01 Off-hook
I 26 ENDPOINT IDENTIFIER.....Len= 2
 01 USID.....001
  E8 TID.....104
  Interpreter.....1
Hex:00 D1 06 06 08 01 01 05 04 03 80 90
A2 18 01 8B 24 01 02 36 01 01 96 23
01 01 26 02 01 E8

```

Setup from TE

Operation

```
NT->TE:C SAPI:000 TEI:104 Time00:01:37.2
I Ns=003 Nr=004 P/F=0
PD=08.....Call Reference:001
M 0D SETUP ACKNOWLEDGE
I 18 CHANNEL ID.....Len= 1
  89 Indicated Channel.....Exclusive
  Channel Selection.....B1
  Channel Identifier.....Not D-CH
I 34 SIGNAL.....Len= 1
  00 Dial Tone on
I 96 Shift          Locking Codeset=6
I 3C DISPLAY FIELD.....Len= 4
  11 Display Mode.....Normal
  Submode.....Direct
01 Field Type.....Call Appear ID
  INFO:1
Hex:02 D1 06 08 08 01 81 0D 18 01 89 34
  01 00 96 3C 04 11 01 20 31
TE->NT:C SAPI:000 TEI:104 Time00:01:42.3
I Ns=004 Nr=004 P/F=0
PD=08.....Call Reference:001
M 7B INFORMATION
I 2C KEYPAD.....Len= 1
  33 Keypad info = 3
Hex:00 D1 08 08 08 01 01 7B 2C 01 33
```

Network
Acknowledgment

TE Dialing

NOTE: *If the "Second Call" feature is ON and two calls are active, the assigned TEI numbers will appear on each message decode. Follow the applicable TEI number to follow messages for a particular call.*

Operation

2.11 ONE PERSON ISDN BRI TURN-UP

2.11.1 EQUIPMENT

Model 550B ISDN Portable Test Set
Model 560B ISDN Dial Up Test Unit

2.11.2 GENERAL INFORMATION

The TPI Model 550B ISDN Portable Test Set is used to conduct testing of ISDN circuits at the Customer Premise or the main Distribution Frame. The Model 550B's operating modes allow it to function as a Network Termination [NT1], as Terminal Equipment [TE], or as both. It may be connected to either the Digital Subscriber Loop [DSL], or the S/T Interface. Once connected, the Model 550B will allow the technician to perform line quality measurements, place Voice and Data calls, set up Loopbacks, conduct BERT testing, and verify translations.

The TPI Model 560B ISDN Dial Up Test Unit is used for automated assistance in the turning up of new ISDN circuits. The Model 560B is normally installed permanently in the Central Office [CO] in a 19-inch rack. The CO will assign a number to allow a test technician to dial the Model 560B. Once accessed, the Model 560B will allow the technician to test the line that he is calling on by ringing the technician back, setting up Loopbacks, and/or allowing BERT testing.

Operation



2.11.3 EQUIPMENT SET-UP

Model 550B

Connection to the ISDN line are made at the LINE INTERFACE Jack on the Front Panel of the Model 550B.

- 1) When the Model 550B is first used on an ISDN circuit, the technician will have to set the Unit up in accordance with the Switch and other line parameters. For example, upon power up of the Model 550B, a screen such as the typical screen shown below will be displayed, which reflects the last setup:



```
* * PRESENT SETUP * *
ISDN NT1TE 2B1Q 5ESS
PP
ACCEPT CHANGE
```

- 2) If the set-up needs to be changed, select "**CHANGE**" and follow the Menu set-up prompts.

Operation

Model 560B

Connections to the ISDN Switch are made at the Model 560B rear panel, via the terminal block [near the center].

- 1) Connect the Tip lead to the terminal marked "T".
- 2) Connect the Ring lead to the terminal marked "R" of the line that is dedicated to the Model 560B.
- 3) The line connected to the Model 560B must be set up as if it were an actual ISDN line being supplied to a customer with translation for Automatic Number Identification [ANI].
- 4) When the Model 560B is first installed, the technician will have to set the Unit up in accordance with the Switch and other line parameters. For example, upon power up, a screen such as the typical screen shown below will be displayed, which reflects the last set up:

```
ISDN NT1TE 2B1Q 5ESS PP  
1=ACCEPT 2=CHANGE
```

- 5) If the set-up needs to be changed, select "2" and follow the Menu set-up prompts.

Operation

2.11.4 VOICE TURN-UP PROCEDURE

Once the Model 560B has been setup properly, the STATUS LED's for "SYNC", "ACTIVE" and "READY" should illuminate.

Once the Model 550B has been set-up properly, the STATUS LED's for "SYNC" and "ACTIVE" should illuminate.

- 1) Go Off Hook - Dial Tone should be heard [if not, check SPID].
- 2) The Model 550B defaults to Voice service.
- 3) Enter the Model 560B Access Number.
- 4) The Model 560B will automatically answer and announce "Hello, TPI Automated Test Line", followed by the Service (Voice or Data), Calling Party Number (repeated), and "Hang Up for call back", to the Model 550B.
- 5) Following this message, the technician should hang up, by going ON HOOK with the Model 550B.
- 6) The Model 560B then goes OFF HOOK and places a call back to the Model 550B.
- 7) When the Model 550B answers, the Model 560B will announce "Hello, TPI Automated Test Line. Entering Loopback", then enter a Loopback state on the assigned "B" channel, allowing BERT testing with the Model 550B to verify the quality of the line.
- 8) The Model 560B will release automatically if the Caller hasn't hung up after 15 minutes.
- 9) The Model 560B is now ready for the next call.

2.11.5 CIRCUIT SWITCHED DATA TURN-UP PROCEDURE

- 1) Same as Voice, except the Model 550B must be configured for Circuit Switched Data via the UTILITY Menu, prior to connection to the line under test.

Operation

**2.11.6 D-PACKET DATA TURN-UP
PROCEDURE**

- 1) Configure the Model 550B for Voice and verify DIAL TONE, upon going OFF HOOK. Hang up by going ON HOOK. Use the UTILITY Menu to change the Bearer capability to "D PKT".
- 2) Using the Model 550B, Go OFF HOOK and the Display should say "**READY/ENTER NUMBER W/KEYS**".
- 3) Using the Model 550B, enter the Model 560B Access Number, followed by "#", to send the number.
- 4) The Model 560B will automatically answer and send the Calling Party Number back in a D-Packet message.
- 5) The Model 550B should display "**Connect_D**", followed by the Calling Party Number.
- 6) Using the Model 550B, hang up by going ON HOOK.
- 7) The Model 560B will go OFF HOOK and dial the Model 550B.
- 8) When the Model 550B sees the D-Packet call come in, it will automatically answer.
- 9) The Model 560B will then send a message to the Model 550B stating "TPI Automated Test Line. Entering Loopback". Next, the Model 560B will enter into a Packet Echo mode.
- 10) The Model 550B can now be used to send the Quick Brown Fox message by selecting "1" on the Keypad.
- 11) When this message reaches the Model 560B, it will be sent back to the Model 550B and displayed on the Screen.
- 12) The Model 550B can Clear the Screen [Select "2"], and Resend the Message [Select "1"]. If this message is received error free, the quality of the connection is verified.
- 13) The Model 550B will release the call automatically if the Caller hasn't hung up after 15 minutes.

Operation



APPENDIX A
QUICK REFERENCE



SECTION II

OPERATION

HOW TO MAKE A VOICE CALL

Complete the *SETUP* menu selections including the correct mode, line code, call control, SPID, TID, directory number, and TEI before accessing the line under test.

ISDN switches may take up to a minute to initialize when access is gained and/or when a mode change takes place. If the "**Hook On/Off**" key is pressed during this initialization period, a "**WAITING FOR RESPONSE**" message may be displayed.

- ❶ **GO OFF HOOK** by pressing the "**Hook On/Off**" keypad button (will hear dial tone).
- ❷ **ENTER THE NUMBER** using the keypad (LCD screen will display number entered and channel selected).
- ❸ **CONVERSATION** may now take place using the "**Hands Free**" feature (an external handset may also be connected).

*TO END a Voice Call, go **On Hook** by pressing the "**Hook On/Off**" keypad button.*

Quick Reference

TROUBLESHOOTING TIPS

- ❶ For **Northern switches** and **AT&T Multipoint circuits**, the **"SPID"** must be entered prior to going off hook (use **"Setup"** key).
- ❷ **"TEI" assignment** must have been made before a dial tone can be heard. (Check for the **"Ready"** LED or use the **"Status/States"** menu to verify Layer 2 state).
If **TEI is assigned**, message on second line of LCD = **"MULT FRAME EST"**
If **TEI is not assigned**, message on second line = **"TEI UNASSIGNED"**.
- ❸ If dial tone has not been gained, a cause message will be displayed on the LCD. For more information, the **"Status"** menu can be accessed to view the **CAUSE INFO**, which will give a diagnostic cause message.
- ❹ If set-up needs to be checked, press the **"Setup"** keypad button, which will prompt the operator to answer several setup related questions that will configure the Model 550B to the circuit and switch being accessed.

Quick Reference

HOW TO MAKE A DATA CALL

Complete the *SETUP* menu selections including the correct mode, line code, call control, SPID, TID, directory number, and TEI *before* accessing the line under test.

ISDN switches may take up to a minute to initialize when access is gained and/or when a mode change takes place. If the "Hook On/Off" key is pressed during this initialization period, a "WAITING FOR RESPONSE" message may be displayed.

- ❶ Press the "#/Utility" keypad button.
- ❷ Press the "Data" soft key. The "BEARER CAPABILITY" sub-menu is gained.
- ❸ Select "DATA".
- ❹ A Circuit Switched Data Call may now be placed, just like a voice call.
 - A - GO OFF HOOK, by pressing the "Hook On/Off" keypad button (may hear dial tone).
 - B - ENTER THE NUMBER, using keypad (LCD screen will display number entered and channel selected).
 - C - BERT testing may now take place.

TO END a Data Call, Go On Hook by pressing the "Hook On/Off" keypad button.

Quick Reference

TROUBLESHOOTING TIPS

- ❶ It is best to verify that a Voice Call can be made successfully, prior to attempting a Data Call.
- ❷ For **Northern switches** and **AT&T Multipoint circuits**, the **"SPID" must be entered** prior to going off hook (use **"Setup"** soft key).
- ❸ **"TEI" assignment** must have been made before going off hook. (Check for the **"Ready"** LED or use the **"Status/States"** menu to verify Layer 2 state).
If **TEI is assigned**, message on second line of LCD = **"MULT FRAME EST"**
If **TEI is not assigned**, message on second line = **"TEI UNASSIGNED"**.
- ❹ If dial tone has not been gained, a cause message will be displayed on the LCD. For more information, the **"Status"** menu can be accessed to view the **CAUSE INFO**, which will give a diagnostic cause message.
- ❺ If set-up needs to be checked, press the **"Setup"** keypad button, which will prompt the operator to answer several setup related questions that will configure the Model 550B to the circuit and switch being accessed.

Quick Reference

HOW TO MAKE A DUAL B-CANNEL CALL

Complete the SETUP menu selections for mode, line code, call control, bearer service, etc.

*Complete the selections for second call, dual TEI, and two SPID entries **before** accessing "PH #2".*

ISDN switches may take up to a minute to initialize when access is gained and/or when a mode change takes place. If the "Hook On/Off" key is pressed during this initialization period, a "WAITING FOR RESPONSE" message may be displayed.

- ❶ Use the SETUP key to configure the test set for the line under test.
- ❷ Press the UTILITY key and select the MODES soft key. Use the Scroll Menu key to move to the "SECOND CALL" screen. The Model 550B defaults to OFF. Select ON.
- ❸ Use Scroll Menu to move to the "DUAL TEI MODE" screen. The selection must be ON unless the line under test is a 5ESS Point-to-Point custom or National ISDN.
- ❹ Press the EXIT soft key to move to the HOOK screen.
- ❺ Press the SPID soft key and check SPID #1.
- ❻ Press the ENTER soft key after checking SPID #1 which moves to the ENTER SPID #2 screen. Enter SPID #2. Press the EXIT soft key to return to the HOOK screen for PH #1 (Phone number 1). Pressing Scroll Menu moves back and forth between the PH #1 and PH #2 HOOK screens.
- ❼ Go Off Hook by pressing the "Hook On/Off" key from the PH #1 screen. Enter the number and establish the call.

Quick Reference

- ⑧ Press "Scroll Menu" to reach the PH #2 Hook screen. Go Off Hook and place a call by entering a number.
- ⑨ Bit Error Testing can be initiated over either of the B-Channels.
- ⑩ To end a call from either PH #1 or PH #2 Hook screen press the "Hook On/Off" key to go On Hook.

TROUBLESHOOTING TIPS

- ① If a second Voice call is attempted and cannot be accomplished, check the Setup. Lines with 5ESS Custom and National call controls and Pt-to-Pt service will not allow dual Voice calls.
- ② Check correct SPID entry. Two required for all setups except 5ESS Pt-to-Pt custom and National ISDN.
- ③ Check correct TEI setting (Dual On or Off). Use the "Utility/MODES" menus.
- ④ **"TEI" assignment** must have been made before a dial tone can be heard. (Check for the **"Ready"** LED or use the **"Status/States"** menu to verify Layer 2 state).
 - If **TEI is assigned**, message on second line of LCD = **"MULT FRAME EST"**
 - If **TEI is not assigned**, message on second line = **"TEI UNASSIGNED"**.
- ⑤ If dial tone has not been gained, a cause message will be displayed on the LCD. For more information, the **"Status"** menu can be accessed to view the **"Status"** menu to check the **CAUSE INFO**, which will give a diagnostic cause message.
- ⑥ If set-up needs to be checked, press the **"Setup"** keypad button, which will prompt the operator to answer several setup related questions that will configure the Model 550B to the circuit and switch being accessed."

Quick Reference

D Packet for
TEI = Fixed 21 = (Dms)
LCD = 01
RPA = NONE A-7

D-Packet Calls

HOW TO MAKE A D-CHANNEL PACKET DATA CALL

Complete the **SETUP** menu selections including the correct mode, line code, call control, SPID, TID, directory number, and TEI **before** accessing the line under test.

ISDN switches may take up to a minute to initialize when access is gained and/or when a mode change takes place. If the "Hook On/Off" key is pressed during this initialization period, a "WAITING FOR RESPONSE" message may be displayed.

- ❶ Press the "#/Utility" keypad button.
- ❷ Press the "Data" soft key. The "BEARER CAPABILITY" sub-menu is gained.
 - Select "PACKET".
- ❸ Press the "Hook On/Off" keypad button (the LCD display will indicate "ENTER NO W/KEYS").
- ❹ **ENTER THE NUMBER** using the keypad.
- ❺ Press the "#/Utility" keypad button to send the call (lower LCD line = "CONNECT_D").
- ❻ Press the "1/Status" keypad button to send the following message over the D-Channel "The quick brown fox jumped over the lazy dog 012".
- ❼ The Model 550B will display any information coming to it on the LCD screen.

* TO END a D-Channel Packet Data Call,
Go On Hook by pressing "Hook On/Off".

031-429-549-620002
031-429-549-630002
1-954-433-9944

031 346 146 458400

Quick Reference

TROUBLESHOOTING TIPS

- ❶ It is best to verify that a Voice Call can be made successfully, prior to attempting a Data Call.
- ❷ For **Northern switches** and **AT&T Multipoint circuits**, the "**SPID**" **must be entered** prior to going off hook (use "**Setup**" key).
- ❸ "**TEI**" **assignment** must have been made before a dial tone can be heard. (Check for the "**Ready**" LED or use the "**Status/States**" menu to verify Layer 2 state).
If **TEI is assigned**, message on second line of LCD = "**MULT FRAME EST**"
If **TEI is not assigned**, message on second line = "**TEI UNASSIGNED**".
- ❹ If dial tone has not been gained, a cause message will be displayed on the LCD. For more information, the "**Status**" menu can be accessed to view the **CAUSE INFO**, which will give a diagnostic cause message.
- ❺ If set-up needs to be checked, press the "**Setup**" keypad button, which will prompt the operator to answer several setup related questions that will configure the Model 550B to the circuit and switch being accessed.
- ❻ If the lower LCD status line doesn't indicate "**READY**" when the "**Hook On/Off**" button is pressed, the X.25 link hasn't been made.
- ❼ If the lower LCD status line doesn't indicate "**CONNECT_D**" when the "**#/Utility**" keypad button is pressed to send the call, the call was not successful.

Quick Reference

ONE PERSON VOICE TURN-UP PROCEDURE

Once the Model 560B has been set-up properly, the "SYNC", "ACTIVE" and "READY" STATUS LED's should illuminate.

Once the Model 550B has been set-up properly, the "SYNC" and "ACTIVE" STATUS LED's should illuminate.

- ❶ Go OFF HOOK - DIAL TONE should be heard [if not, check SPID].
- ❷ The Model 550B defaults to Voice service.
- ❸ Enter the Model 560B Access Number.
- ❹ The Model 560B will automatically answer and announce "Hello, TPI Automated Test Line", followed by the Service (Voice or Data), Calling Party Number (repeated), and "Hang Up for call back" to the Model 550B.
- ❺ Following this message, the technician should hang up, by going ON HOOK with the Model 550B.
- ❻ The Model 560B then goes OFF HOOK and places a call back to the Model 550B.
- ❼ When the Model 550B answers, the Model 560B will announce "Hello, TPI Automated Test Line. Entering Loopback", then enter a Loopback state on the assigned "B" channel, allowing the technician to use the BERT feature of the Model 550B to verify the quality of the connection.
- ❽ The Model 560B allows the user to select a time limit (via the "Utility" menu) before hanging up automatically.
- ❾ The Model 560B is now ready for the next call.

ONE PERSON CIRCUIT-SWITCHED DATA TURN-UP

- ❶ Same as Voice, except the Model 550B must be configured for Circuit Switched Data via the UTILITY Menu, prior to connection to the line under test.

Quick Reference

ONE PERSON D-PACKET DATA TURN-UP PROCEDURE

- ❶ Configure the Model 550B for Voice and verify DIAL TONE, upon going OFF HOOK. Hang up by going ON HOOK. Use the UTILITY Menu to change the Bearer capability to "D PKT".
- ❷ Using the Model 550B, Go OFF HOOK and the Display should say "READY/ENTER NUMBER W/KEYS". Using the Model 550B, enter the Model 560B Access Number, followed by "#", to send the number.
- ❸ The Model 560B will automatically answer and send the Calling Party Number back in a D-Packet message.
- ❹ The Model 550B should display "Connect_D", followed by the Calling Party Number. Using the Model 550B, hang up by going ON HOOK.
- ❺ The Model 560B will go OFF HOOK and dial the Model 550B.
- ❻ When the Model 550B sees the D-Packet call come in, it will automatically answer.
- ❼ The Model 560B will then send a message to the Model 550B stating "TPI Automated Test Line. Entering Loopback". Next, the Model 560B will enter into a Packet Echo mode.
- ❽ The Model 550B can now be used to send the "Quick Brown Fox" message by selecting "1" on the Keypad. When this message reaches the Model 560B, it will be sent back to the Model 550B and displayed on the Screen.
- ❾ The Model 550B can Clear the Screen [Select "2"], and Resend the Message [Select "1"]. If this message is received error free, the quality of the connection has been verified.
- ❿ The Model 550B will release the call automatically if the Caller hasn't hung up after 15 minutes.

Quick Reference

2B1Q EOC MESSAGES

"2B+D LOOPBACK"
"B1 LOOPBACK"
"B2 LOOPBACK"
"REQ CRPT CRC"
"NOTIFY CRPT CRC"
"RETURN NORMAL"
"HOLD STATE"
"UNABLE COMPLY ACK" by NT1

2B1Q LAYER 1 MESSAGES

"H1 FULL RESET" (Interface is being reset)
"H2 ALERTING" (Interface is trying to alert network)
"H6 ISW SYNC" (Sync has been found on inverted sync word)
"H8 ACTIVE" (Interface is active)
"H10 TEAR DOWN" (Interface in process of being torn down)

AT&T AMI N-CHANNEL DOWNSTREAM MESSAGES

"D 1 NT 2B+D LB" = Loopback 2B+D at NT1
"D 2 NT B1 LB" = Loopback Chan. B1 at NT1
"D 3 NT B2 LB" = Loopback Chan. B2 at NT1
"D 6 ACT MODE/IDLE" = Activated Mode/Idle
"D 8 ACT REQUEST" = Activation Request
"D 15 DEACTIVATED" = Out of Service/Deactivated

AT&T AMI N-CHANNEL UPSTREAM MESSAGES

"U 1 AWAKE INDICATION" = Request by TE to activate S/T Interface
"U 6 ACTMODE/IDLE" = Idle condition
"U 7 S/T NOT EST" = Lack of sync at S/T Interface
"U 15 DEACTIVATED" = Out of Service/Deactivated

Quick Reference

LAYER 2 MESSAGES

TEI UNASSIGNED	= Power up state
ASSIGN AWAITING TEI	= Requesting TEI state
ESTABLISH AWAITING TEI	= Requesting TEI state
TEI ASSIGNED	= TEI has been assigned
AWAITING ESTABLISHMENT	= Not yet in multiple frame state
AWAITING RELEASE	= Release request from multiple frame state
MULTIPLE FRAME ESTABLISHED	= Completed SABME / UA (This is the state the 550B should be in when ready to place a call.)
TIMER RECOVERY	= Error State

Quick Reference

LAYER 3 MESSAGES

NULL STATE	= No call exists
CALL INIT	= The state for an outgoing call.
OVERLAP SENDING	= Call establishment request acknowledgement has been received permitting additional call information to be sent in the overlap mode.
OUT CALL PROC	= Outgoing Call Proceeding
CALL DELIVERED	= Remote user alerting has been initiated.
CALL PRESENT	= State exists for an incoming call.
CALL RECEIVED	= Incoming call not yet answered.
CONNECT REQUEST	= Incoming call answered, waiting to Be awarded.
IN CALL PROC	= Incoming Call Proceeding
CALL ACTIVE	= Incoming or outgoing call state.
DISCONNECT REQ	= (Disconnect request) Request for network to clear the end-to-end connection.
DISCONNECT IND	= (Disconnect Indication) Receipt of invitation to disconnect.
SUSPEND REQUEST	= Request for network to suspend the call.
RESUME REQUEST	= Request for network to resume a previously suspended call.
RELEASE REQUEST	= Request for network to release a call.
OVERLAP RECEIVE	= (Overlap Receiving) Network is prepared to receive additional call information (if any) in overlap mode.
IDLE STATE	= (IDLE CALL STATE) On Hook. No calls in progress.

Quick Reference

CAUSE MESSAGES	
1 "UNASSIGNED NUM"	2 "NO ROUTE TO NET"
3 "NO ROUTE TO DEST"	6 "CHN UNACCEPTABLE"
7 "CALL AWARDED"	16 "NORMAL CLEARING"
17 "USER BUSY"	18 "NO USER RESPONSE"
19 "ALERTING NO ANS"	21 "CALL REJECTED"
22 "NUMBER CHANGED"	26 "NON SELECTED CLR"
27 "DEST OUT ORDER"	28 "INVALID NUM FMT"
29 "REQ FACILITY REJ"	30 "RSP TO STAT ENQ"
31 "NORM UNSPEC"	34 "NO CHAN AVAIL"
35 "QUEUED"	38 "NET OUT ORDER"
41 "TEMP FAILURE"	42 "NETWORK CONGEST"
43 "INFO DISCARDED"	44 "CHN NOT AVAIL"
47 "RESOURCE UNAVAIL"	49 "QUAL SVC UNAVAIL"
50 "FAC NO SUBSCRIB"	52 "OUT CALLS BARRED"
54 "IN CALLS BARRED"	57 "BEARCAP NOT AUTH"
58 "BEARCAP NOT AVAI"	63 "SERVC NOT AVAIL"
65 "BEARSVC NOT IMPL"	66 "CHN TYPE NOT IMPL"
69 "REQ FAC NOT IMPL"	70 "RES DIGITAL ONLY"
79 "SVC NOT IMPLEMNT"	81 "INVAL CALL REF"
82 "CHN NOT EXIST"	83 "NO CALL ID"
84 "CALL ID IN USE"	85 "NO CALL SUSPEND"
86 "CALL CLEARED"	88 "INCOMPAT DEST"
91 "NET NOT EXIST"	95 "INVALID MSG"
96 "INFOELEMENT MISS"	97 "MSG TYPE NONEXST"
98 "MSG NOT COMPAT"	99 "ELEMENT NONEXIST"
100 "INVAL INFO"	102 "RECOV ON TMR EXP"
111 "PROTOCOL ERROR"	127 "INTERWORKING"

1 "UNASSIGNED NUM"	2 "NO ROUTE TO NET"
3 "NO ROUTE TO DEST"	6 "CHN UNACCEPTABLE"
7 "CALL AWARDED"	16 "NORMAL CLEARING"
17 "USER BUSY"	18 "NO USER RESPONSE"
19 "ALERTING NO ANS"	21 "CALL REJECTED"
22 "NUMBER CHANGED"	26 "NON SELECTED CLR"
27 "DEST OUT ORDER"	28 "INVALID NUM FMT"
29 "REQ FACILITY REJ"	30 "RSP TO STAT ENQ"
31 "NORM UNSPEC"	34 "NO CHAN AVAIL"
35 "QUEUED"	38 "NET OUT ORDER"
41 "TEMP FAILURE"	42 "NETWORK CONGEST"
43 "INFO DISCARDED"	44 "CHN NOT AVAIL"
47 "RESOURCE UNAVAIL"	49 "QUAL SVC UNAVAIL"
50 "FAC NO SUBSCRIB"	52 "OUT CALLS BARRED"
54 "IN CALLS BARRED"	57 "BEARCAP NOT AUTH"
58 "BEARCAP NOT AVAI"	63 "SERVC NOT AVAIL"
65 "BEARSVC NOT IMPL"	66 "CHN TYPE NOT IMPL"
69 "REQ FAC NOT IMPL"	70 "RES DIGITAL ONLY"
79 "SVC NOT IMPLEMNT"	81 "INVAL CALL REF"
82 "CHN NOT EXIST"	83 "NO CALL ID"
84 "CALL ID IN USE"	85 "NO CALL SUSPEND"
86 "CALL CLEARED"	88 "INCOMPAT DEST"
91 "NET NOT EXIST"	95 "INVALID MSG"
96 "INFOELEMENT MISS"	97 "MSG TYPE NONEXST"
98 "MSG NOT COMPAT"	99 "ELEMENT NONEXIST"
100 "INVAL INFO"	102 "RECOV ON TMR EXP"
111 "PROTOCOL ERROR"	127 "INTERWORKING"

Quick Reference



APPENDIX B

GLOSSARY

AMI *Alternate Mark Inversion* - A switch vendor's proprietary line code (i.e., AT&T AMI, NTI AMI).

ANI *Automatic Number Identification* - Ability of the network to notify the called party of the calling party's number.

B-Channel *Bearer Service Channel* - Operates at 64 Kbps and carries user voice and data.

BERT *Bit Error Testing*

BPV *Bipolar Violation*

BRI *Basic Rate Interface* - One of the access methods to an ISDN circuit. Comprising of either 1B+D or 2B+D channels.

BRITL *Basic Rate Interface Dial Up Test Line* - A feature of AT&T switches.

Cause Message - Diagnostic messages describing the "cause" of a problem.

CCIS *Common Channel Interoffice Signaling* - North American version of Signaling System 6.

CCS *Common Channel Signaling* - Out of band network signaling whereby several voice trunks share a common signaling channel (i.e., SS6 and SS7).

CLASS *Custom Local Area Signaling Services* - A set of services that is offered by telcos that have implemented SS7.

CODEC *Coder/Decoder* - Device used to convert analog signals to digital bit streams and vice versa.

CPE *Customer Premise Equipment* - Devices or equipment that the customer provides to interface with the telco.

Glossary

CRC *Cyclic Redundancy Check* - A mathematical algorithm used to detect bit errors in data transmission.

CUG *Closed User Group* - A group of packet data users designated as a specific group; one that can be reached by adding a special code to the call request packet for a packet data call.

D-Channel - The out of band signaling channel that carries ISDN network signals. It can also be used to carry packet-mode user data. The D-Channel operates at 16 Kbps in the BRI and 64 Kbps in the PRI.

DCE *Data Circuit-terminating Equipment*

DSL *Digital Subscriber Line*

DTE *Data Terminal Equipment*

EBS *Electronic Business Set* - Also known as P-Phone, this is a proprietary service provided by Northern Telecom DMS or SL switches.

EOC *Embedded Operations Channel*

HDLC *High-level Data Link Control*

IEC *Inter-Exchange Carrier* - In the U.S. is a long distance telephone company (also abbreviated IC and IXC).

ISDN *Integrated Services Digital Network*

ISPBX *Integrated Services Private Branch Exchange* - A term describing an ISDN-compatible PBX.

IVDT *Integrated Voice/Data Terminal* - An ISDN terminal that allows both voice and data communications.

LAPD *Link Access Procedures on the D-Channel* - The ISDN data link layer protocol specified for the D-Channel.

LCGN *Logical Channel Group Number*

LCN *Logical Channel Number* - Used to designate the virtual channel to be used by a packet data call at the network interface.

M-Channel - A 4 Kbps maintenance channel for NT1-LE communication over the 2-wire BRI circuit

Modulo - Maximum number of states for a counter. Used to describe several packet-switched network parameters, such as packet number (usually set to modulo 8 - counted from 0 to 7). When the maximum count is exceeded, the counter is reset to 0.

Multi Point - Configuration that supports multiple terminal equipment devices.

National ISDN - A standard call control for NI-1, 2, and 3.

NT1 *Network Termination type 1* - The ISDN device responsible for the termination of the ISDN transmission facility at the customer premises.

NT2 *Network Termination type 2* - An ISDN device responsible for on premises communications distribution, such as a PBX, LAN, or Host Computer.

Octet - An eight (8) bit quantity; used in lieu of the term "Byte".

PLP *Packet Layer Protocol* - The X.25 Level 3 protocol.

Point to Point - Point to point connection.

Glossary

POTS - S/T Interface

POTS *Plain Old Telephone Service*

PRI *Primary Rate Interface* - One of the access methods to an ISDN circuit. Comprising of 23 B-Channels and one D-Channel (23B+D).

Reverse Charge - A call option with a packet data call requesting a reversal of charges to the called party

RPOA *Registered Private Operating Agency* - A call option in packet data calls naming a specific network within a country reachable by a specific call through the Public Packet Network.

SAPI *Service Access Point Identifier* - A subfield in the LAPD address field which indicates the type of Level 3 service being obtained.

Sonalert - An audible "beep" indicating an error condition or signaling an incoming call.

SPID *Service Profile Identifier* - A number used by Terminal Equipment to request identification from the switch on a multipoint circuit.

SPM *Service Profile Management*

SS6 *Signaling System No. 6* - CCITT version of CCIS, one of the first common channel signaling networks.

SS7 *Signaling System No. 7* - The high speed, digital common channel signaling network required for ISDN applications.

S/T Interface - The standard 4-wire (2 Rx, 2 Tx) ISDN Interface used by ISDN terminals and is the physical interface on the terminal side of a NT1.

Glossary



STP *Signal Transfer Point* - A SS7 switching point.

TE *Terminal Equipment* - Any ISDN compatible device that may be placed on the network, such as a telephone, IVDT, PBX, TV, PC, etc.

TE1 *Terminal Equipment type 1* - ISDN compatible terminal equipment.

TE2 *Terminal Equipment type 2* - Non-ISDN compatible terminal equipment.

TEI *Terminal Endpoint Identifier* - A subfield in the LAPD address field that identifies a given TE device on the ISDN interface.

TID *Terminal Identifier*

Transport Layer *Layer 4 of OSI Reference Model* - Primarily responsible for error free communication between two hosts across the subnetwork.

2B1Q *Two Binary One Quaternary* - A signaling method used across the 2-wire BRI (U reference point). 2B1Q is a four level line code associating 2 bits to each line signal.

U Interface - The physical 2-wire echo canceling interface on the network side of a NT1.

USID *User Service Identifier*

Window - The number of unacknowledged packets that may be accepted before an error condition is determined.

Glossary



INDEX

2B1Q, *See* Interfaces
2B1Q Interface Mode, 1-63 to 1-64
40 KHz Tone, 1-67

A

Accessories, 1-88 to 1-89
AMI, B-1
ANI, B-1
Auto Configure, 1-46
Auto Power Down, 1-65

B

B-Channel, 1-43, 1-60, B-1
Backlighting, *See* LCD Backlight
Backspace, 1-52, 1-71
Battery Recharge, 1-8, 1-19, 1-92
Battery Status, 1-65
Bearer Capability, 1-69 to 1-70
BERT Key, 1-47 to 1-48
Bit Error Testing, 1-47 to 1-51
BRI, *See* ISDN
BRITL, 1-54 to 1-57, B-1

C

Cables, 1-88 to 1-89
Calibration, 1-90
Call Appearance, 1-61
Call Control, 1-26, 1-60
Calling
 Data, 1-69, 1-81 to 1-84, A-3 to A-4
 D-Packet, 1-69 to 1-70, 1-85 to 1-87, A-7 to A-8
 Dual B-Channel, 1-57 to 1-59, 1-78, 2-13 to 2-17,
 A-5 to A-6
 Voice, 1-69, 1-75 to 1-80, A-1 to A-2

Index

Call User Data, 1-71 to 1-72
Cause, 1-40 to 1-42, A-14, B-1
CCIS, B-1
CCS, B-1
Circuit-Switched Turn-Up, A-9
CLASS, B-1
CLID, 1-43
CODEC, B-1
Connections, 1-9
 Data Access, 1-17, 1-92
 Hand Set, 1-19, 1-92
 LINE Interface, 1-11, 1-92
 S/T Interface, 1-15, 1-92
Contrast, *See* LCD Contrast
Controls, 1-10 to 1-21
 Keypad, 1-11, 1-22 to 1-87
 Term Switch, 1-15
CPE, B-1
CRC, B-1
CUG, 1-73, B-2
D
Data Access, *See* Connections
Data Calls, *See* Calling
D-Channel, B-2
D-Channel Monitor, 1-69, 2-29 to 2-31
D-Channel Packet Data Calls, 1-69 to 1-70, 1-85 to 1-87,
 A-5 to A-6
D-Channel Packet Data Turn-Up, A-10, 2-36
Description
 Physical, 1-8 to 1-9, 1-92
 Operational, 1-93

Index

Dimensions, 1-8, 1-92
Dual Calls, 1-57 to 1-59, 1-78, 2-13 to 2-17, A-5 to A-6

E

Easy-User-Mode, 2-1 to 2-2
EBS, B-2, *See also* P-Phone
EOC, A-11, B-2
Error Counters, 1-45, 1-47

F

Feature Verification, 1-54 to 1-57
Firmware version, 1-63, 2-3
Flow Control, 1-70

H

Hand Set, *See* Connections
HDLC, B-2

I

IEC, B-2
Indicators, 1-10 to 1-21, 1-95
 Batt. Low LED, 1-19, 1-95
 Off Hook LED, 1-21, 1-95
 Sealing Current LED, 1-4, 1-95
 Status LEDs, 1-13, 1-95
 PS LEDs, 1-15, 1-95
Interface Select, 1-26
Interfaces, 1-1, 1-63, 1-89, 1-92
 2B1Q, 1-7, 1-89, 1-92, B-5
 AT&T AMI, 1-89, 1-92
 LINE (U), 1-5, 1-11, 1-46, 1-92, 2-11, B-5
 S/T, 1-6, 1-15 to 1-17, 1-92, 2-12, B-5

Index

ISDN, 1-3 to 1-7, B-2

2B1Q Line Code, 1-7

Basic Rate Interface, 1-4, B-1

Network Termination (NT), 1-6

S/T Interface, 1-6

Terminal Equipment (TE), 1-7

U Interface, 1-5

ISPBX, B-3

IVDT, B-3

K

Keypad, *See* Controls

L

LAPD, B-3

Layer 1 Messages, 1-34 to 1-36, A-11

Layer 2 Messages, 1-37, A-12

Layer 3 Messages, 1-38 to 1-39, A-13

LCD, 1-11, 1-91

Backlight, 1-63

Contrast, 1-64

LCN, 1-93, B-3

Line Interface, *See* Interfaces

Loopbacks, 1-66

Loss Insertion, 1-66

LT Mode, 1-63 to 1-64

M

M-Channel, 1-33 to 1-34, B-3

Maintenance, 1-90 to 1-91

Measurements, 1-1, 1-94

Modes of Operation, 1-1, 1-93

NT1, 1-5, 2-28

TE, 1-6, 2-12

NT1/TE, 2-11

Index

Multipoint Operation, 1-31, B-3

Modulo, 1-70, 1-74, B-3

N

National ISDN, B-3

NT1, B-3

NT2, B-3

N-Channel Messages, 1-35, A-11

O

Octet, B-4

Off Hook LED, *See* Indicators

One Person ISDN BRI Turn-Up, 2-32 to 2-36, A-9 to A-10

 Circuit-Switched Data, 2-35, A-9

 D-Channel Packet Data, 2-36, A-10

 Voice, 2-35, A-9

Operational Specifications, *See* Specifications

P

PDN, 1-31

Physical Description, *See* Description

PLP, B-3

POTS, 2-26 to 2-27, B-3

P-Phone, 2-18 to 2-25

Power, 1-19, 1-92

Power Up, 2-1 to 2-2

Pre-Qualification, 2-8 to 2-10

PRI, B-4

R

Redial, 1-29

Results, 1-45

Reverse Charge, 1-73, B-4

RPOA, 1-74, B-4

Index

S

SAPI, B-4

Second Call Feature, 1-57 to 1-59, 1-78, 2-13 to 2-17
A-5 to A-6

Set TEI, 1-61

Set Test Time, 1-45

Setup, 1-24 to 1-28

Specifications, 1-92 to 1-95
Operational, 1-93
Physical, 1-92

Speed Dial
Operation, 1-30
Programming, 1-52

SPID, 1-31, 2-6, B-4, *See also* Multipoint Operation

SPM, 1-42, B-4

SS6, B-4

SS7, B-4

S/T Interface, *See* Interfaces

Status Reporting, 1-32 to 1-45

Store, 1-52

STP, B-5

T

TE, 1-4, B-5

TE1, B-5

TE2, B-5

TEI, 1-43, 1-61, B-5

Termination, *See* Controls - Term Switch