

**ML11367
Rev. A**

**T-BERD 224
PCM ANALYZER
OPERATING MANUAL**

APRIL 1991

**©Telecommunications Techniques Corporation 1990
20410 Observation Drive
Germantown, MD 20876
(301) 353-1550 or (800) 638-2049
Fax. (301) 353-0731**

TABLE OF CONTENTS**TABLE OF CONTENTS**

SECTION	PAGE
1.0 GENERAL INFORMATION	1-1
1.1 INTRODUCTION	1-1
1.2 INSTRUMENT OVERVIEW	1-1
1.3 OPERATING CONFIGURATIONS	1-5
1.4 APPLICATIONS	1-6
2.0 INSTRUMENT DESCRIPTION	2-1
2.1 INTRODUCTION	2-1
2.2 FUNCTIONAL DESCRIPTION	2-1
2.3 CONTROLS, INDICATORS, AND CONNECTORS	2-3
2.4 CONNECTIONS	2-34
2.5 AUXILIARY FUNCTIONS	2-41
2.6 MEASUREMENTS	2-46
3.0 PREPARATION FOR USE	3-1
3.1 INTRODUCTION	3-1
3.2 UNPACKING AND INITIAL INSPECTION	3-1
3.3 EQUIPMENT INCLUDED	3-1
3.4 WARNINGS	3-1
3.5 POWER REQUIREMENTS	3-2
3.6 INSTRUMENT CHECKOUT	3-2
3.7 SELF-TEST PROCEDURE	3-5
4.0 OPERATION	4-1
4.1 INTRODUCTION	4-1
4.2 INSTRUMENT SET-UPS AND CONNECTIONS APPLICATIONS	4-2
4.3 IN-SERVICE TESTING APPLICATIONS	4-14
4.4 OUT-OF-SERVICE TESTING APPLICATIONS	4-20
5.0 PRINTER OPERATION	5-1
5.1 INTRODUCTION	5-1
5.2 COMPATIBLE PRINTERS	5-1
5.3 PRINTOUTS	5-1
5.4 OPERATING WITH THE OPTIONAL LID PRINTER	5-7
5.5 PRINTER CONNECTIONS	5-9
6.0 REMOTE CONTROL OPERATION	6-1
6.1 INTRODUCTION	6-1

TABLE OF CONTENTS

SECTION	PAGE
6.2 RS-232 REMOTE CONTROL OPERATION	6-1
6.3 IEEE-488 INTERFACE	6-9
6.4 ERROR MESSAGES	6-9
6.5 REMOTE CONTROL COMMANDS	6-13
7.0 SPECIFICATIONS	7-1
7.1 INTRODUCTION	7-1
7.2 GENERAL SPECIFICATIONS	7-1
7.3 INPUT SPECIFICATIONS	7-2
7.4 OUTPUT SPECIFICATIONS	7-3
7.5 MEASUREMENTS	7-3
7.6 CONNECTORS	7-5
7.7 FRONT PANEL	7-13
7.8 GROUNDING	7-17
8.0 MAINTENANCE AND SERVICE	8-1
8.1 INTRODUCTION	8-1
8.2 MAINTENANCE	8-1
8.3 SERVICE	8-2
9.0 OPTIONS AND ACCESSORIES	9-1
9.1 INTRODUCTION	9-1
9.2 OPTIONS	9-1
9.3 ACCESSORIES AND CABLES	9-4
10.0 IEEE-488 INTERFACE OPTION	10-1
10.1 INTRODUCTION	10-1
10.2 CONTROLS AND INDICATORS	10-1
10.3 CONNECTIONS	10-3
10.4 IEEE-488 PRINTER OPERATION	10-4
10.5 IEEE-488 REMOTE CONTROL OPERATION	10-4
10.6 SPECIFICATIONS	10-12
11.0 ZBTSI FRAMING OPTION	11-1
11.1 INTRODUCTION	11-1
11.2 OPERATION AND SIGNAL FLOW	11-2
11.3 CONTROLS AND INDICATORS	11-3
11.4 REMOTE CONTROL OPERATION	11-3
12.0 DSU-DP OPTION	12-1
12.1 INTRODUCTION	12-1
12.2 FUNCTIONAL DESCRIPTION	12-4

TABLE OF CONTENTS

SECTION	PAGE
12.3 CONTROLS AND INDICATORS	12-4
12.4 DSU-DP OPTION CONNECTIONS	12-10
12.5 AUXILIARY FUNCTIONS	12-12
12.6 TESTING	12-14
12.7 ERROR MESSAGES	12-26
12.8 REMOTE CONTROL COMMANDS	12-27
12.9 SPECIFICATIONS	12-34
13.0 BIT ERROR RATE TEST OPTION	13-1
13.1 INTRODUCTION	13-1
13.2 FUNCTIONAL DESCRIPTION	13-3
13.3 CONTROLS AND INDICATORS	13-4
13.4 AUXILIARY FUNCTIONS	13-18
13.5 TEST PATTERNS	13-32
13.6 MEASUREMENTS	13-36
13.7 OUT-OF-SERVICE TESTING	13-42
13.8 REMOTE CONTROL OPERATION	13-57
13.9 SPECIFICATIONS	13-90
14.0 VF OPTION	14-1
14.1 INTRODUCTION	14-1
14.2 FUNCTIONAL DESCRIPTION	14-3
14.3 CONTROLS AND INDICATORS	14-3
14.4 AUXILIARY FUNCTIONS	14-7
14.5 MEASUREMENTS	14-12
14.6 OUT-OF-SERVICE TESTING	14-14
14.7 ERROR MESSAGES	14-29
14.8 REMOTE CONTROL COMMANDS	14-30
14.9 SPECIFICATIONS	14-46
15.0 ENHANCED ESF AND SLC-96 OPTION	15-1
15.1 INTRODUCTION	15-1
15.2 SLC-96 MODE OPERATION	15-3
15.3 SLC-96 ALARMS AND MEASUREMENTS	15-11
15.4 SLC-96 MODE TESTING	15-15
15.5 SLC-96 MODE REMOTE CONTROL COMMANDS	15-26
15.6 ESF AND ESFZ MODE OPERATION	15-38
15.7 ESF PERFORMANCE REPORT MESSAGE RESULTS	15-43
15.8 TESTING T1 ESF CIRCUITS	15-47
15.9 ESF MODE REMOTE CONTROL COMMANDS	15-51

TABLE OF CONTENTS**SECTION** **PAGE****APPENDICES**

A.	FACTORY DEFAULT SETTINGS	A-1
B.	CHANNEL TIME SLOT ASSIGNMENTS	B-1
C.	OPERATING MESSAGES	C-1
D.	MINIMUM/MAXIMUM STRESS PATTERN	D-1
E.	SWITCH CONFIGURATIONS AND AUX FUNCTIONS	E-1

TABLES

2-1	AUTO MODE SELECTIONS	2-9
2-2	T-BERD 224 MAINFRAME SWITCH CONFIGURATIONS	2-14
2-3	SUMMARY RESULTS CATEGORY	2-47
2-4	BPV & FRAME RESULTS CATEGORY	2-48
2-5	SIGNAL RESULTS CATEGORY	2-49
2-6	CONFIGURATION VS. DISPLAYED RESULTS	2-53
2-7	TIME RESULTS CATEGORY	2-55
2-8	CHANNEL RESULTS CATEGORY	2-56
4-1	TEST SET-UP FOR MONITORING A T1 CIRCUIT	4-4
4-2	TEST SET-UP FOR DROP AND INSERT TESTING	4-8
4-3	TEST SET-UP FOR T1 CIRCUIT TERMINATION	4-13
4-4	PROCEDURE FOR LISTENING TO A VOICE CIRCUIT	4-15
4-5	PROCEDURE FOR OBSERVING SIGNALING STATES OF ALL 24 CHANNELS	4-17
4-6	PROCEDURE FOR TESTING FOR TIMING SLIPS	4-19
4-7	TEST PROCEDURE FOR INSERTING A 1004 HZ TONE ON A VF CHANNEL	4-24
4-8	TEST PROCEDURE FOR TESTING DDS CHANNELS	4-29
5-1	RS-232 PRINTER/REMOTE CONTROL INTERFACE CONFIGURATION	5-9
5-2	PR-40A PRINTER CONFIGURATION	5-10
5-3	RS-232 CONNECTOR PIN ASSIGNMENTS	5-10
6-1	PRINTER/REMOTE RS-232 CONNECTOR CONFIGURATION	6-2
6-2	RS-232 CONNECTOR PIN ASSIGNMENTS	6-2
6-3	MANUAL REMOTE CONTROL OPERATION SET-UP	6-5
6-4	AUTOMATIC REMOTE CONTROL OPERATION SET-UP	6-5
6-5	SWITCH COMMANDS	6-14
6-6	AUXILIARY FUNCTION COMMANDS	6-16
6-7	CONTROL COMMANDS	6-16
6-8	T-BERD 224 MAINFRAME REMOTE CONTROL COMMANDS	6-18

TABLE OF CONTENTS

TABLE	PAGE
7-1 RS-232 PIN CONFIGURATION	7-7
7-2 T-BERD 224 TEST POINTS	7-8
10-1 PRINTER/REMOTE IEEE-488 CONNECTOR PIN ASSIGNMENTS	10-3
12-1 DSU-DP OPTION SWITCH CONFIGURATIONS	12-9
12-2 DSU-DP OPTION T1 SLC-96 SWITCH CONFIGURATIONS	12-10
12-3 RS-232 MALE-TO-FEMALE ADAPTOR CABLE	12-15
12-4 RS-232 MALE-TO-MALE ADAPTOR CABLE	12-15
12-5 V.35 MALE-TO-FEMALE ADAPTOR CABLE	12-16
12-6 V.35 MALE-TO-MALE ADAPTOR CABLE	12-16
12-7 RS-449 MALE-TO-FEMALE ADAPTOR CABLE	12-17
12-8 RS-449 MALE-TO-MALE ADAPTOR CABLE	12-17
12-9 "Y" ADAPTOR CABLE	12-18
12-10 TEST PROCEDURE FOR ANALYZING A DATA CHANNEL'S PROTOCOL	12-21
12-11 TEST PROCEDURE FOR REPLACING FRACTIONAL T1 DSU/CSU	12-25
12-12 DSU-DP OPTION REMOTE CONTROL COMMANDS	12-27
12-13 DSU-DP RE-232 CONNECTOR PIN ASSIGNMENTS	12-35
12-14 DSU-DP V.35 CONNECTOR PIN ASSIGNMENTS	12-36
12-15 DSU-DP RS-449 CONNECTOR PIN ASSIGNMENTS	12-38
13-1 BERT OPTION SWITCH CONFIGURATIONS	13-5
13-2 LOOP CODES	13-26
13-3 TESTING DDS CHANNELS	13-31
13-4 LOGIC CATEGORY RESULTS	13-38
13-5 SIGNAL CATEGORY RESULTS	13-39
13-6 CHANNEL CATEGORY RESULTS	13-40
13-7 REPORTABLE DS0 CONTROL CODES	13-41
13-8 FULL T1 OUT-OF-SERVICE TEST	13-44
13-9 TESTING FROM THE CUSTOMER PREMISES	13-49
13-10 DDS OUT-OF-SERVICE TEST	13-54
13-11 REMOTE CONTROL COMMANDS	13-58
14-1 VF OPTION SWITCH CONFIGURATION	14-1
14-2 VF OPTION CHANNEL CATEGORY MEASUREMENTS	14-12
14-3 COLLECTING C-MESSAGE NOISE RESULTS	14-15
14-4 COLLECTING C-NOTCH NOISE AND S/N RATIO RESULTS	14-16
14-5 COLLECTING THREE TONE SLOPE RESULTS	14-20
14-6 COLLECTING RETURN LOSS RESULTS	14-23
14-7 COLLECTING FREQUENCY SWEEP RESULTS	14-26
14-8 COLLECTING P/AR RESULTS	14-28

TABLE OF CONTENTS

TABLE	PAGE
14-9 VF OPTION REMOTE CONTROL COMMANDS	14-30
15-1 ENHANCED ESF/SLC OPTION SWITCH CONFIGURATIONS	15-5
15-2 NOTE AND ACU ALARM MESSAGES	15-7
15-3 SIGNALING STATES FOR SLC-96 SYSTEM CHANNEL UNITS	15-9
15-4 SUMMARY CATEGORY RESULTS	15-13
15-5 TEST SET-UP FOR MONITORING THE SLC-96 DATALINK	15-17
15-6 TEST SET-UP FOR DIALING INTO THE CO	15-22
15-7 TEST SET-UP FOR LOOPING THE SHELF LINE	15-25
15-8 SLC-96 MODE REMOTE CONTROL COMMANDS	15-26
15-9 BPV & FRAME CATEGORY PRM TEST RESULTS	15-45
15-10 TEST SET-UP FOR TESTING AN T1-ESF CSU	15-49
A-1 FACTORY DEFAULT SETTINGS	A-1
B-1 CHANNEL TIME SLOT ASSIGNMENTS	B-1
C-1 T-BERD 224 MAINFRAME OPERATING MESSAGES	C-1
C-2 BERT OPTION OPERATING MESSAGES	C-4
C-3 VF OPTION OPERATING MESSAGES	C-6
C-4 ENHANCED ESF/SLC OPTION OPERATING MESSAGES	C-8

FIGURES

2-1 T-BERD 224 FRONT PANEL	2-4
2-2 T-BERD 224 DISPLAY	2-5
2-3 AUX SWITCH	2-7
2-4 MODE SWITCH	2-8
2-5 CHANNEL FORMAT SWITCH	2-12
2-6 SOURCE CONFIGURATION SWITCHES	2-13
2-7 RESULTS SWITCHES AND RESULTS WINDOWS	2-18
2-8 RESTART AND HISTORY RESET SWITCHES, LOCAL STATUS, AND HISTORY LEDS	2-20
2-9 LOOP CODE AND SIGNALING INSERT PUSHBUTTON SWITCHES	2-24
2-10 ERROR INSERT AND VOLUME SWITCHES	2-26
2-11 CHANNEL, RECEIVE INPUT, INSERT, AND DROP SWITCHES	2-28
2-12 TEST, PRINT, PRINT EVENT, AND CODE SWITCHES	2-32
2-13 T-BERD 224 FRONT PANEL CONNECTOR LOCATIONS	2-35
2-14 AUXILIARY PORT CONNECTION	2-36
2-15 T-BERD 224 SIDE PANEL CONNECTOR LOCATIONS	2-38
2-16 TIMING SLIPS	2-51
2-17 TIMING SLIPS RESULTS DISPLAY	2-51

TABLE OF CONTENTS

FIGURE		PAGE
2-18	BAR GRAPH AND WHEEL VALUES	2-52
5-1	RESULTS PRINTOUT	5-2
5-2	CONTROLS PRINTOUT	5-5
10-1	SERIAL POLL REGISTER BYTE	10-7
12-1	T-BERD 224 SIDE PANEL CONNECTOR LOCATIONS	12-11
12-2	EQUIPMENT CONNECTIONS FOR ANALYZING A DATA CHANNEL'S PROTOCOL	12-20
13-1	LOOPBACK TEST SET-UP	13-43
13-2	CUSTOMER PREMISES TEST SET-UP	13-48
13-3	DDS TEST SET-UP	13-53
14-1	FREQUENCY SWEEP PRINTOUT	14-11
14-2	VOICE-GRADE NOISE TESTING SET-UP	14-18
14-3	THREE TONE SLOPE TESTING SET-UP	14-22
15-1	CONNECTIONS FOR MONITORING THE SLC-96 DATALINK	15-16
15-2	CONNECTIONS FOR DIALING INTO THE CO SWITCH	15-21
15-3	CONNECTIONS FOR LOOPING AND TESTING A SHELF LINE	15-24
15-4	T-BERD 224 T1 AND DATALINK PRM SIGNAL FLOW	15-39
15-5	CONNECTIONS FOR TESTING A T1-ESF CSU	15-48

GENERAL INFORMATION

1.1 INTRODUCTION

This manual provides information about the physical features, functional operation, and specifications of the Telecommunications Techniques Corporation (TTC) T-BERD 224 PCM Analyzer. Basic T-BERD 224 Mainframe information is presented in Sections 1 through 9. Each T-BERD 224 option and its affect upon the T-BERD 224 is discussed separately in Sections 10 through 15. You only need refer to the section(s) for the option(s) installed on your T-BERD 224.

For information about the basic T-BERD 224 channel access test set, including initial set-up for testing at a T1 access point, use the T-BERD 224 Mainframe sections that describe basic features and test procedures. For information on what additional capabilities are added by a particular option and how to use them, refer to the appropriate section for that option. Each option's section includes a description of its affect on front panel switches, connections, and test applications.

1.2 INSTRUMENT OVERVIEW

The T-BERD 224 PCM Analyzer is a comprehensive, full-duplex, T1 channel access test set. It provides test and monitor access to VF, DS0, fractional T1 (FT1), DS0A, DS0B, and datalink channels from virtually any T1 access point. Single and dual drop capabilities allow users to hear or observe live voice and data traffic. Bi-directional drop and insert capabilities allow users to insert test tones or data into a channel(s) in either T1 transmission direction to perform out-of-service tests. The T-BERD 224 has two T1 receivers and two T1 transmitters, it may be placed in-line, at which point it provides "hitless" drop and insert in either direction.

Typically used in central offices and at the customer premises, the T-BERD 224 provides circuit installation and fault isolation testing capabilities. It allows users to easily troubleshoot problems with voice and data circuits that are transmitted within T1 interoffice trunks, digital loop carrier systems, and dedicated leased circuits. Remote control capabilities allow the T-BERD 224 to be rack-mounted in unmanned facilities and connected to test ports of digital cross-connect switches and matrix switches.

SECTION 1

1.2.1 Standard Features

The T-BERD 224 offers the following standard features and capabilities:

- Auto mode configuration allows the unit to automatically determine the incoming T1 signal's framing and coding and to configure the T-BERD 224 transmitters and receivers to the appropriate framing format.
- A SUMMARY Results Category allows key non-zero and out-of-specification results to be accessed from one results category without having to search through several menus.
- Full-duplex drop and insert capabilities enable performance of out-of-service tests in either T1 transmission direction.
- Built-in speaker enables the user to monitor VF transmissions in one or both directions.
- Traffic analysis provides a simultaneous display of all 24 channel signaling bits for one or both T1 transmission directions.
- Multiple side panel interfaces provide full-duplex channel access to external test sets through 2- or 4-wire VF interfaces and a 64 kb/s DS0 interface.
- Dual T1 receivers compatible with D1D, D2, D3/D4 (Superframe), ESF (Extended Superframe), and SLCTM-96 framing formats provide simultaneous BPV, frame, and CRC error results, as well as received frequency and signal level (in volts peak-to-peak, dBdsx, or dBm) measurements for both T1 inputs.
- Timing slip analysis detects differences in system timing between two T1 inputs or between a T1 input and an external reference signal. Gives a visual indication of wander and the potential for frame slips.
- Signaling bit control allows users to emulate signaling toward switches, PBXs, and channel banks.
- VF signal analysis supplies measurement of a tone's level and frequency within a VF channel.

- User-selectable AMI or Bipolar 8-zero substitution (B8ZS).
- Error insert capability provides BPV, frame error, and yellow alarm insertion into one of the T1 data streams.
- Full-span capability lets the T-BERD 224 replace the CSU or Smart Jack, pass simplex current, and receive signal levels down to -35 dBm.
- RS-232 remote control allows the T-BERD 224 to be used in unmanned central offices, at remote customer premises, and on manufacturing production lines.
- All controls and indicators are located on the front panel. Current test set-ups are confirmed at a glance.

1.2.2 Optional Features

The following options are currently available for the T-BERD 224.

IEEE-488 Remote Control Option (Model 41243) ***(see Section 10)***

Enables the T-BERD 224 to operate in IEEE-488 (HP-113) remote control environments.

Offers both addressable and talk-only operating modes.

ZBTSI Framing Option (Model 11425) ***(see Section 11)***

Adds capability to test and analyze T1 ESF (Extended Superframe) circuits that use ZBTSI encoding.

RS-232/V.35 DSU-DP Interface Option (Model 41441) ***(see Section 12)***

Provides full-duplex drop and insert access to synchronous data at a variety of customer data rates, including DS0A-Framed DDS, DS0B-Framed DDS, Clear Channel, fractional T1, and ESF datalink.

SECTION 1

RS-232/RS-449 DSU-DP Interface Option (Model 41249) ***(see Section 12)***

Provides full-duplex drop and insert access to synchronous data at a variety of customer data rates, including DS0A-Framed DDS, DS0B-Framed DDS, Clear Channel, fractional T1, and ESF datalink.

BERT (Bit Error Rate Testing) Option (Model 41500) ***(see Section 13)***

Enables the T-BERD 224 to perform out-of-service bit error rate tests on T1, fractional T1, and DDS circuits with 17 different test patterns.

Tests both DS0A and DS0B formatted DDS circuits.

Transmits in-band and out-of-band (ESF) loop codes.

Sends both alternating and latching DDS loop codes for sectionalizing and troubleshooting DDS circuits.

Emulates T1 CSUs by terminating the T1 span and auto-responding to T1 loop codes.

Tests both DDS PRIMARY and SECONDARY channels.

Enables the T-BERD 224 to measure simplex current and round trip delay.

Enables the T-BERD 224 to insert single, burst, or continuous logic, BPV, and frame errors.

VF Option (Model 41502) ***(see Section 14)***

Enables the T-BERD 224 to test VF circuits at the T1 access points.

Measures signal-to-noise ratio (S/N), C-Message and C-Notch voice level noise, 3 kHz Flat, and 3 kHz-Notch noise.

Performs Peak-to-Average Ratio (P/AR), Echo Return Loss (ERL), and Singing Return Loss High and Low (SRL-HI and SRL-LO) tests on a VF circuit.

Enhanced SLC-96 and ESF Option (Model 11704)
(see Section 15)

Enables the T-BERD 224 to monitor and transmit T1.403 performance report messages (PRMs) on ESF and ESFz framed circuits.

Monitors major, minor, power, and miscellaneous alarms, and it detects protection switches and maintenance activity on SLC-96 framed circuits.

Sends major, minor, and power alarms, as well as performs far-end loops on SLC-96 framed circuits

Thermal 40-Column Lid Printer (Model 41297)

For ordering information on these optional features, refer to Section 9, Options and Accessories. For more detailed descriptions of these optional features refer to the indicated sections.

1.3 OPERATING CONFIGURATIONS

The T-BERD 224 Mainframe can be operated in any of the following modes:

- **T1 Performance Monitoring** — Analyzes both T1 inputs simultaneously for receive frequency, receive level, and for errors, such as BPVs, frame errors, and CRC errors.
- **Drop - Simplex or Duplex** — Drops voice or data from one line or both lines to the internal speaker or to an external test set through the side panel interfaces.
- **Drop and Insert** — Inserts test tones or data into a selected voice or data channel(s) of either LINE 1 or LINE 2. The channel(s) from the opposite line may be dropped and monitored.
- **Test Loopback** — Loops T1 signals from each line's receiver to the other line's transmitter. Received data is transmitted with BPVs removed. The **ERROR INSERT** switches are enabled, allowing BPV, frame error, and yellow alarm to be inserted into the data stream. The **CODE** switch is also enabled, allowing B8ZS coding to be removed or inserted. The incoming signal is monitored for errors, frequency, and level.

SECTION 1

- **Line Loopback** — Loops T1 signals from each line's receiver to the other line's transmitter. All data received is echoed by the transmitter. BPVs are not stripped and the **ERROR INSERT** and **CODE** switches are disabled. The incoming signal is monitored for errors, frequency, and level.
- **Remote Control Operation** — Test circuits in unmanned central offices using a remotely controlled, rack-mounted T-BERD 224.

1.4 APPLICATIONS

Applications for the T-BERD 224 are divided into three categories: T-BERD 224 instrument set-up and connections applications, in-service testing applications, and out-of-service testing applications. These applications are described in the following paragraphs.

1.4.1 Instrument Set-Up and Connections Applications

- Non-intrusive T1 circuit monitoring set-up (see Section 4.2.1).
- Drop and insert testing set-up (see Section 4.2.2).
- T1 circuit termination set-up (see Section 4.2.3).

1.4.2 In-Service Testing Applications

- Listen to one or both sides of a VF circuit to verify and isolate reported problems (see Section 4.3.1).
- Detect under-used and busied-out circuits quickly by observing all 24 channel signaling bits simultaneously (see Section 4.3.2).
- Perform timing slips analysis (see Section 4.3.3).
- Test analog data circuits, which are transmitted within the T-Carrier, using an external 4-wire VF test set.

- Record real-time wink duration, wink response time, pulse start time, and guard time using an external chart recorder connected to TTL test points.

1.4.3 Out-of-Service Testing Applications

- Verify circuit continuity with the internal 1004 Hz digital milliwatt signal (see Section 4.4.1.1).
- Inserting signals on a DDS circuit from an external test set (see Section 4.4.1.2).
- Simulate channel signaling by modifying A and B or A, B, C, and D signaling bits to check switch and PBX configurations.
- Measure VF channel level and frequency when installing new circuits.
- Stress VF circuit line cards by modifying signaling bits and sending DTMF tones using an external set.
- Perform DDS loopback tests from T1 access points with an external FIREBERD or KS-type test set.
- Observe DDS control codes using the byte decoder.

SECTION 1

INSTRUMENT DESCRIPTION

2.1 INTRODUCTION

This section contains a functional description of the T-BERD 224 PCM Analyzer, followed by descriptions of the front panel controls and indicators, as well as the side panel interfaces. Information on the T-BERD 224 Options are discussed in Sections 10 through 15.

2.2 FUNCTIONAL DESCRIPTION

The T-BERD 224 PCM Analyzer is a full duplex test set that allows users to drop and/or insert channels from framed (D1D, D2, D3/D4, ESF, ZBTSI (optional), or SLC-96), byte formatted (24 DS0s) T1 circuits. Although most applications for the T-BERD 224 occur from a DSX-1 patch panel or from the test jacks on a CSU, the T-BERD 224 is unique in that it can replace T1 CSUs: the T-BERD 224 can be connected directly to the span, loop simplex current and receive signals at levels as low as -35 dBdsx. Whether the T-BERD 224 is used in the central office or at the customer premises, many operating configurations are provided, including:

- T1 performance monitoring
- Dropping channels (simplex or duplex)
- Inserting test data or tones onto one or more channels

T1 performance monitoring is non-intrusive and allows users to analyze T1 circuit performance while it is carrying live traffic. Whenever a T1 signal of valid frequency and level is present at either the LINE 1 or LINE 2 input receiver (regardless of the drop and insert configurations), the T-BERD 224 automatically begins to analyze the input and provide performance monitoring results, such as frequency, level, bipolar violations, frame errors, and CRC errors. If two T1 inputs are present, (or if an external clock is connected to the side panel EXTERNAL BNC CLOCK connector) the T-BERD 224 also performs timing slip analysis, detecting shifts between the two signals' clock frequencies.

The T-BERD 224 allows users to drop a channel(s) from Line 1, Line 2, or both lines without disrupting the T1 signal. The **CHANNEL FORMAT**

SECTION 2

switch configures the T-BERD 224 to analyze either voice or data circuits. Users select the designated channel for each line using the **LINE 1** and **LINE 2 CHANNEL** switches. Drop sources (e.g., **LINE 1**, **LINE 2**, or **BOTH**) are selected using the **DROP** switch. When monitoring a voice channel, the signal is routed to the internal speaker and the side panel 2- and 4-wire voice frequency (VF) interfaces. VF level and frequency measurements are available in the **CHANNEL** category, while the signaling bit states for both T1 inputs may be observed simultaneously. When monitoring a data channel, the dropped channel(s) is provided to the DS0 for analysis by an external BERT, KS-type DDS, protocol, or data scope test set. The 8-bit byte for the designated channel is sampled, decoded, and displayed in the **CHANNEL** category for the DS0 channel.

The T-BERD 224 also allows users to insert test tones or data into a T1 channel without disrupting the data in the remaining 23 channels. The T-BERD 224 is placed in-line so that the entire T1 circuit for at least one transmission direction is passing through the test set. Once the test set is synchronized to the incoming signal's framing pattern, test tones or data may be inserted into the designated line's channel(s), overwriting the original data. The insert source, such as a 1004 Hz tone or a signal source from an external test set, is determined by the **SOURCE CONFIGURATION** switches. The selected test signal is inserted into the channel(s) selected by the **INSERT** and **CHANNEL** switches. Note that the **INSERT** selection must be for the T1 signal that passes through the test set. If performing a loopback test, connect the T1 circuit's return path to the T-BERD 224, select the proper channel number, and set the **DROP** switch to the line number opposite that of the **INSERT** switch.

When the T-BERD 224 is placed in-line, such that the T1 signal(s) is passing through the test set and the receiver detects a loss of signal, the T-BERD 224 transmits an AIS for the indicated line. If the T-BERD 224 is in-line and receiving an AIS or yellow alarm, the T1 signal(s) is retransmitted unchanged.

If the T-BERD 224 is acting as the T1 signal source for either Line 1 or Line 2, such that no T1 signal is present at a line's input, the T-BERD 224 generates a framed, all ones T1 signal using the user-selected backup timing source (either the internal clock crystal or an external clock source present at the side panel BNC connector). Users may still insert test data or tones into the selected channel(s) while an all ones pattern is inserted into the remaining channels.

The T-BERD 224 comes complete with "dead man" relays which close automatically upon power loss. These relays are necessary to prevent signal

disconnect when a T1 circuit is passing through the unit and the unit loses power. Note that for this feature to work properly, the T-BERD input receivers and transmitters must be connected to the line (not resistor-isolated monitor jacks) and the input terminations set to TERM, since the signal is not regenerated by the T-BERD 224.

The T-BERD 224 may be controlled locally using the front panel switches or remotely using the PRINTER/REMOTE RS-232 connector or IEEE-488 Remote Control Option (see Section 10, IEEE-488 Remote Control Option). The remote control receivers are interrupt driven, while the transmitter is polled.

2.3 CONTROLS, INDICATORS, AND CONNECTORS

This section describes the T-BERD 224 front panel controls, indicators, and connectors. The side panel connectors are also discussed. Figure 2-1 shows the T-BERD 224 front panel. The numbers for each item in Figure 2-1 correspond to the bracketed numbers in the following sections.

2.3.1 Display

Operating modes, setup configurations, test results, and auxiliary functions are displayed in the 80-character, green vacuum fluorescent display (see Figure 2-2). The display is divided into six sections. The left four sections display set-up selections and the right two sections display results. The set-up sections display MODE, CHANNEL FORMAT, SOURCE CONFIGURATION I, and SOURCE CONFIGURATION II selections. The results sections consist of two independent 2-line by 10-character/line displays.

NOTE: The auxiliary function menus require use of the entire display. The auxiliary functions are visible and configurable when the LED within the **AUX** switch is illuminated.

2.3.2 Controls and Indicators

The T-BERD 224 features two basic types of switches: pushbutton switches and multiposition rocker switches.

Pushbutton switches enable an action when they are first pressed and disable the action when they are pressed again (e.g., **AUX**), or they enable

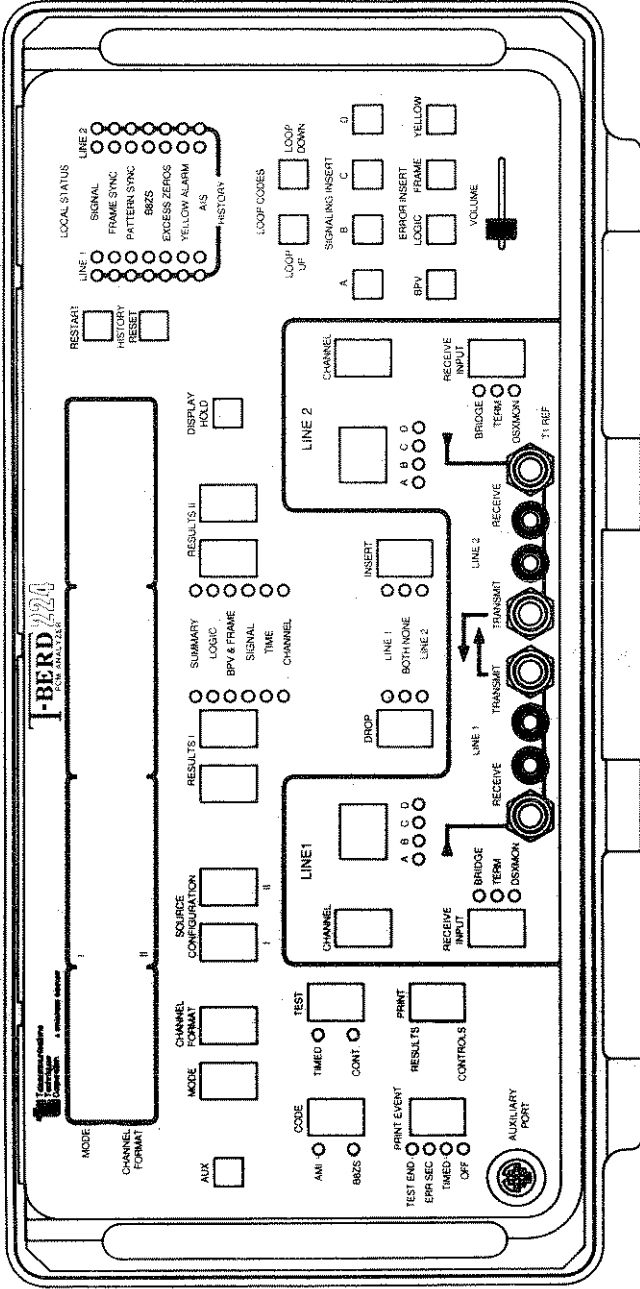

Figure 2-1
T-BERD 224 Front Panel

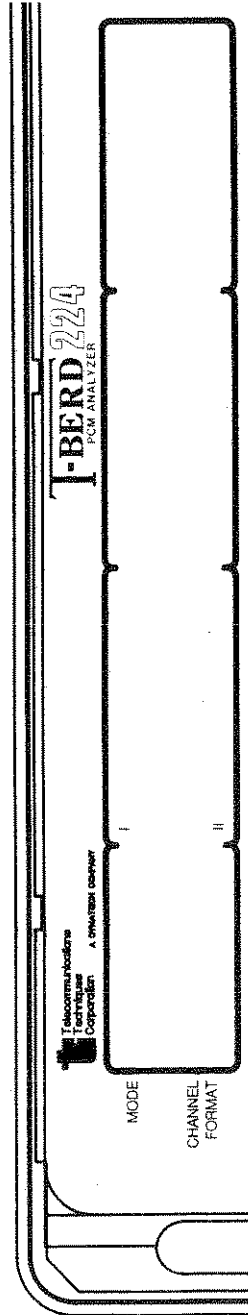

Figure 2-2
T-BERD 224 Display

SECTION 2

an action each time they are pressed (e.g., **RESTART**). Most of the push-button switches feature an LED within the switch which illuminates when the switch function is enabled. For example, pressing the **AUX** switch for the first time illuminates its LED, indicating that the display window is available for configuring auxiliary functions. Pressing the **AUX** switch again extinguishes the LED and returns the display window to its standard display format.

Multiposition rocker switches are used to scroll through and select one of two or more available selections. The rocker switches use LEDs, labels, and the display to indicate the position of the switch, such as the **RESULTS** switches. Some rocker switches have up and down arrows on them. Pressing the up arrow scrolls forward through the available selections and pressing the down arrow scrolls backward through the available selections.

Aside from the display and switch LEDs, the T-BERD 224 also uses LEDs to indicate the status of the received signal(s). These LEDs are color-coded according to the function and condition to which they correspond. Amber LEDs are used to indicate a status condition (e.g., **TEST**), green LEDs are used to indicate positive conditions (e.g., **FRAME SYNC**), and red LEDs are used to indicate history, alarm, or failure conditions (e.g., **EXCESS ZEROS**). In addition, the T-BERD 224 uses seven-segment displays to present the selected **LINE 1** and **LINE 2** channel numbers.

The following information describes the T-BERD 224 front panel controls and indicators. The operating modes and auxiliary functions mentioned are discussed in greater detail in separate sections following this section.

AUX Switch [1]

Press the **AUX** switch to access the auxiliary functions (see Figure 2-3). The LED within the switch illuminates when the auxiliary functions are available in the display. Auxiliary functions allow access to parameters that are less frequently used and do not have dedicated switches. Press the **MODE** switch to scroll through the auxiliary functions. Refer to Section 2.5, Auxiliary Functions, for information on the available auxiliary functions.

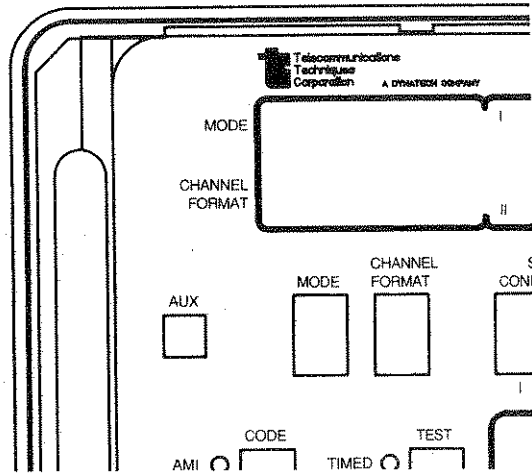

Figure 2-3
AUX Switch

MODE Switch [2]

The **MODE** switch (see Figure 2-4) selects the operating mode. In general, the operating modes specify the type of framing present on the line. Pressing the **MODE** switch up or down scrolls through the available operating modes. When the desired mode is visible in the **MODE** display, the T-BERD 224 is configured for that mode.

NOTE: When the LED inside the **AUX** switch is illuminated, the **MODE** switch is used to scroll through the auxiliary functions without modifying the current test (see Figure 2-3). See Section 2.5 for further information regarding auxiliary functions.

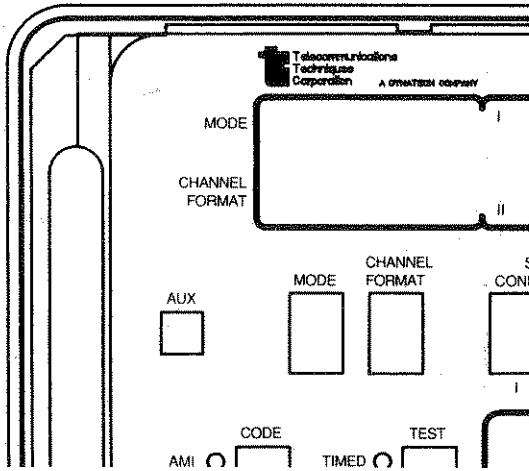

Figure 2-4
MODE Switch

The following is a list of operating mode selections.

- **AUTO** — Configures the unit's receivers to synchronize to the incoming T1 signals automatically and determine the framing format and line coding. Configures the transmitters to the corresponding framing format. Table 2-1 indicates the T-BERD 224 MODE selection for an incoming signal when in AUTO configuration.

In AUTO mode, "scan..." is displayed while the unit determines what framing mode is being received. If frame synchronization is achieved, the detected mode is then displayed in the MODE display in lower case as indicated in Table 2-1.

AUTO mode is performed on both LINE 1 and LINE 2. Assuming T1 signals are connected to both line inputs, the T-BERD 224 first

Table 2-1
AUTO Mode Selections

T1 Signal Format	AUTO Mode Selection
D1D	t1-d4
D2	t1-d4
D4	t1-d4
ESF	t1-esf
ZBTSI (optional)	t1-esfz
SLC-96	t1-slc96
SLC Series 5	t1-esf
Unframed	scan.../FRAMING PATTERN UNKNOWN *

*If "t1" appears with the BERT Option installed, the T-BERD 224 has synchronized to an unframed or non-standard T1 signal.

tries to synchronize to LINE 1 input. Once framing synchronization is achieved, the LINE 1 green FRAME SYNC LED illuminates, and the T-BERD 224 tries to synchronize to the same frame format in LINE 2. If LINE 2 frame format is not the same as LINE 1, then the green LINE 2 FRAME SYNC LED does not illuminate. However, if the T-BERD 224 does not achieve synchronization with LINE 1, LINE 2 is analyzed for framing synchronization. If synchronization is achieved with LINE 2, the LINE 2 green FRAME SYNC LED illuminates. If synchronization is not achieved for either line, the message FRAMING PATTERN UNKNOWN flashes in the display. This process continues until synchronization is achieved or AUTO mode is exited.

NOTE: If the BERT Option is installed, the T-BERD 224 can recognize and synchronize to an unframed T1 signal. Refer to Section 13.3.2, **MODE** Switch, for additional information on the AUTO mode.

- **T1-D1D** — Configures the unit to operate with framed T1 signals using D1D formatting. This framing is commonly encountered on the B, C, and D shelves of Mode I SLC-96 systems.

SECTION 2

- **T1-D2** — Configures the unit to operate with framed T1 signals using D2 formatting.
- **T1-D4** — Configures the unit to operate with framed T1 signals using D4 (Superframe) formatting.
- **T1-ESF** — Configures the unit to operate with framed T1 signals using ESF (Extended Superframe) formatting.
- **T1-SLC-96** — Configures the unit to operate with framed T1 signals using SLC-96 (Subscriber Loop Carrier) formatting. When the T-BERD 224 is used as the signal source, the data link bits are all set to zero. When the Data Link Option is installed, the data link can be analyzed further. Refer to Section 15, Data Link Option, for additional information.

NOTE: The T-BERD 224 generates its SLC-96 framed signal as per specification TR:TS-1-000008. This format is compatible with AT&T SLC-96 systems and similar DLC manufacturers' systems. It may not be compatible with all DLC systems or other test equipment's SLC-96 operating mode.

- **T1-TLB (Test Loopback)** — Loops data from each line's receiver to the opposite line's transmitter while monitoring each input for T1 and channel results. Incoming BPVs are stripped. In this mode, users can NOT insert test signals. However, BPVs, frame errors, and a yellow alarm can be inserted into one of the framed data streams as indicated by the INSERT switch. The CODE switch is also enabled so that B8ZS coding may be removed or inserted. In this mode, unframed data can be accepted, but frame errors and yellow alarms cannot be inserted into the unformatted data stream.
- **T1-LLB (Line Loopback)** — Loops data from each line's receiver, unaffected, to the opposite line's transmitter while monitoring each input for T1 and channel results. BPVs are not stripped and no errors (BPV, frame, or yellow alarm) are inserted.

In TLB and LLB modes an attempt is made to automatically synchronize to a framing format, but no indication is provided as to what the framing format is. If the T-BERD 224 does recognize a framing mode, the FRAME SYNC LED illuminates.

Modifying the MODE selection:

- Causes a test restart
- Changes the frame synchronization parameters and the transmitted frame pattern
- Resets the insert function and re-enables it after 3 seconds if the **INSERT** switch is set to **LINE 1** or **LINE 2**
- May modify the signaling bit displays and the active **SIGNALING INSERT** switches
- May modify the **CHANNEL** number to time slot correspondence
- May change the **CHANNEL FORMAT** or **SOURCE CONFIGURATION** selections

CHANNEL FORMAT Switch [3]

The **CHANNEL FORMAT** switch (see Figure 2-5) selects the type of test the T-BERD 224 will perform. The T-BERD 224 Mainframe can test either voice or data channels on a T1 circuit. The voice or data channel is specified using the **LINE 1** and **LINE 2 CHANNEL** switches. Press the **CHANNEL FORMAT** switch up or down to scroll through the available voice and data channel formats. When the desired channel format appears in the **CHANNEL FORMAT** display, release the switch to select that channel format. Channel format selections are:

VF (Voice Frequency) — Use when testing or monitoring voice frequency circuits. This selection enables the internal speaker, **SIGNALING INSERT** switches, VF channel measurements, and specific drop and insert source configurations.

VF THRU (Voice Frequency Through Signaling) — Use when testing or monitoring voice circuits without disrupting the original signaling states of the channel. This selection enables the internal speaker, VF channel measurements, and specific drop and insert source configurations. The **SIGNALING INSERT** switches are disabled.

DS0 (Digital Signal Level 0) — Use when testing or monitoring 64 kb/s DS0 data circuits. This selection enables the byte decoder and specific drop and insert source configurations.

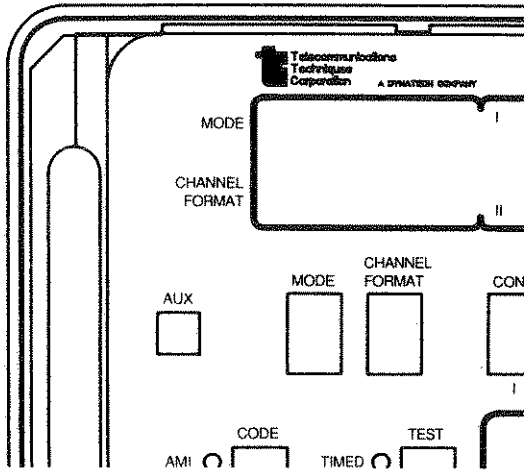

Figure 2-5
CHANNEL FORMAT Switch

Modifying the CHANNEL FORMAT selection:

- Causes a test restart
- Enables the internal speaker if CHANNEL FORMAT is VF or VF THRU
- Enables the **SIGNALING INSERT** switches if CHANNEL FORMAT is VF
- Resets the insert function and re-enables it after 3 seconds if the **INSERT** switch is set to LINE 1 or LINE 2
- May change the available SOURCE CONFIGURATION I and II selections

SOURCE CONFIGURATION Switches [4]

The two **SOURCE CONFIGURATION** switches (see Figure 2-6) work in conjunction to select specific tones/data to be inserted into the specified channels. The **SOURCE CONFIGURATION I (SCI)** switch selects an available drop and insert source (internal or external) which is to be used when analyzing the channel(s) selected using the **CHANNEL**, **DROP**, and **INSERT** switches. The **SOURCE CONFIGURATION II (SCII)** switch clarifies or augments those selections associated with the **SCI** switch. Press either the up or down arrow on each switch to scroll through the available selections.

Available **SCI** switch selections depend on the selected **MODE** and **CHANNEL FORMAT**. Refer to Table 2-2 for the **MODE**, **CHANNEL FORMAT**, and **SCI** and **SCII** switch configurations.

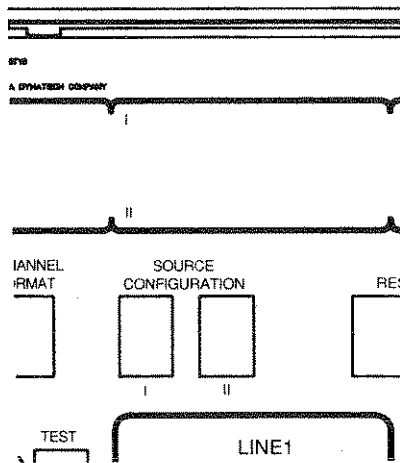

Figure 2-6
SOURCE CONFIGURATION Switches

SECTION 2

**Table 2-2
T-BERD 224 Mainframe Switch Configurations**

Switch/Aux Function	Configuration		
MODE Switch	T1 D1D, T1 D2, T1 D4, T1SLC96, T1 ESF, ESFz*, T1 TLB, T1 LLB		
CHANNEL FORMAT Switch	VF VF THRU	DS0	
SCI Switch	1004 Hz VF INTF DROP CHAN	BYTE	DS0 INTF DROP CHAN
SCH Switch		XXXX XXXX	
AUX 01 CL FIFO	X	X	X
AUX 02 TIM PRI	X	X	X
AUX 03 TES LEN	X	X	X
AUX 04 TIM/DAY	X	X	X
AUX 05 LBO	X	X	X
AUX 06 BACK TM	X	X	X
AUX 07 DS0 TM		X	X
AUX 08 RS 232	X	X	X

* Requires ZBTSI Option

VF INTF (VF Interface) — This selection enables the side panel's 2- or 4-wire VF interface as the drop and insert source. A selected drop channel is decoded and output to the side panel connector. Tones from the external VF signal source that are applied to the side panel connector are inserted into a channel determined by the **INSERT** and **CHANNEL** switch settings.

DROP CHAN (Dropped Channel) — This selection provides a channel loopback, and allows data from a channel which is dropped from one line to be re-inserted into a channel selected by the **INSERT** and **CHANNEL** switch settings. The dropped channel is provided to the side panel's 2-wire and 4-wire VF interfaces. When **DROP CHAN** is selected and the **CHANNEL** for the dropped line is set to **ALL**, time slot 1 is dropped.

With the **CHANNEL FORMAT** switch set to **DS0**, the available **SCI** switch selections are:

BYTE (Byte Encoder) — This selection allows the user to insert an 8-bit byte that is repetitively inserted into the selected channel. The **SCII** switch is used to set the byte contents. The dropped channel is provided to the **DS0** interface.

DS0 INTF (DS0 Interface) — This selection enables the side panel's **DS0** interface as the drop and insert source. A selected drop channel specified by the **DROP** and **CHANNEL** switch settings is output to the side panel connector. Data from the external **KS**-type test set applied to the side panel input connector is inserted into a channel determined by the **INSERT** and **CHANNEL** switch settings. Data is transmitted using the bit and byte clocks output from the side panel connector.

DROP CHAN (Dropped Channel) — This selection provides a channel loopback and allows data from a channel which is dropped from one line to be inserted into a selected channel on the other line. The dropped channel is provided to the **DS0** Interface. When **DROP CHAN** is selected and the **CHANNEL** for the dropped line is set to **ALL**, time slot 1 is dropped.

SECTION 2

Modifying the **SCI** switch selection:

- Modifies available SOURCE CONFIGURATION II selections
- Modifies the drop and insert source for the channel(s) selected by the **DROP**, **INSERT**, and **CHANNEL** switches

Available **SCII** switch selections depend on the selected **MODE**, **CHANNEL FORMAT**, and **SCI** switches. Refer to TABLE 2-2 for an indication of the **MODE**, **CHANNEL FORMAT**, and **SCI** and **SCII** switch configurations.

When the **SCI** switch is set to **BYTE**, the available **SCII** switch selections are:

XXXXXXXX (where X = 1 or 0) — This selection allows the user to set the bits of the 8-bit byte. Press the up arrow to set the bit above the cursor to a 1 and use the down arrow to set the bit to a 0. When the byte is first displayed, the cursor is to the right of the last bit. Pressing the **SCII** switch for the first time moves the cursor to the first bit position on the left. Each time the **SCII** switch is pressed, the bit is set accordingly and the cursor is moved automatically one bit position to the right. The newly encoded byte is transmitted once all 8 bits are set and the cursor is to the right of the last bit. The encoded byte is transmitted within the DS0 with the left-most bit in the display in bit position 1 and the right-most bit in the display in position 8.

NOTE: The cursor must be in the “ninth” position for the displayed byte to be transmitted; otherwise, the previously programmed byte will be transmitted.

Modifying the **SCII** switch selection:

- Causes a test restart
- Edits the transmitted bits within a **BYTE**, if **SOURCE CONFIGURATION I** is set to **BYTE**
- Resets the insert function and re-enables it after 3 seconds if the **INSERT** switch is set to **LINE 1** or **LINE 2**

RESULTS [5]

The results sections of the display (RESULTS I and II display windows) allow two sets of test results to be displayed simultaneously (see Figure 2-7). Below each RESULTS window is a corresponding pair of **RESULTS** switches used to select the category and test result to be displayed. Results for either LINE 1 or LINE 2 can be displayed in either RESULTS window.

Two rocker switches comprise each pair of **RESULTS** switches. The **RESULTS I** and **II Category** switches (blank rocker switches) select one of the six result categories (SUMMARY, LOGIC, BPV & FRAME, SIGNAL, TIME, and CHANNEL) indicated by the illuminated LED next to each category label. The **RESULTS I** and **II Results** switch (rocker switches with arrows) scroll through and display individual test results within the selected category.

The RESULTS window information is preceded by a three-digit result number. The result number is assigned using an NXX format (where N is the LINE number (1 or 2) and XX is the result number (00 to 99) for the indicated LINE). (Refer to Section 2.6, Measurements, for detailed descriptions of each category and test result available.)

NOTE: Changing the **RESULTS** switches selections does not affect the operation of the test in progress.

DISPLAY HOLD Switch [6]

The **DISPLAY HOLD** pushbutton switch (see Figure 2-7) freezes the displayed results and all LOCAL STATUS and HISTORY LED indicators for LINE 1 and LINE 2. When the **DISPLAY HOLD** switch is first pressed, the LED in the switch illuminates to indicate that the results, as well as the STATUS and HISTORY LEDs, are being held and are not current. The display hold is disabled by pressing the **DISPLAY HOLD** switch again, causing the LED within the switch to extinguish. When this function is enabled, the **RESULTS** switches can still be used to scroll through the results, but the **HISTORY RESET** switch is disabled.

NOTE: Even though the displayed results are held, results are still accumulating and a results printout will give the current values. When the display hold is disabled, the results and LEDs are updated to reflect their current values.

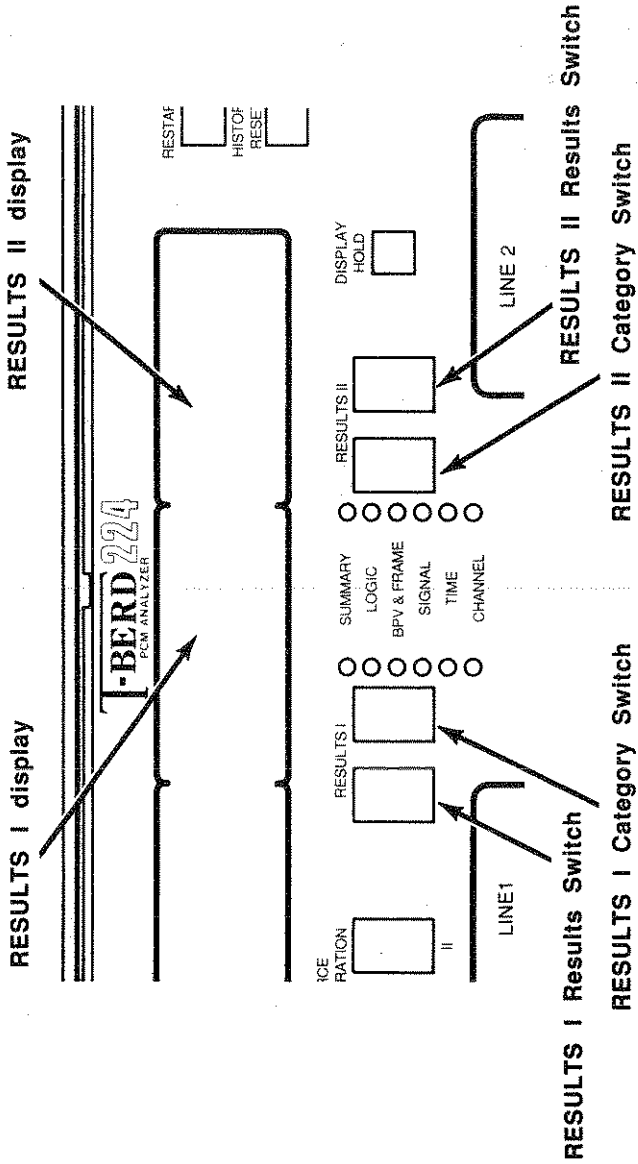

Figure 2-7
RESULTS Switches and RESULTS Windows

Modifying the **DISPLAY HOLD** switch does not override major switch changes (as described in **RESTART** Switch [7]) and affects only:

- Results within RESULTS I and II displays
- STATUS and HISTORY LEDs
- Operation of the **HISTORY RESET** switch

NOTE: With DISPLAY HOLD active, modifying a major switch (as described in **RESTART** Switch [7]) causes a test restart even though the display shows the results of the previous test.

RESTART Switch [7]

The **RESTART** pushbutton switch (see Figure 2-8) causes a test restart that affects any function related to the T-BERD 224 receiver(s), such as test results, status LEDs, and history LEDs. Pressing and holding this switch during power-up clears non-volatile RAM (NOVRAM). Clearing NOVRAM sets all the parameters to their default factory settings as listed in Appendix A.

The following actions will also cause a test restart:

- Pressing any major switch: MODE, CHANNEL FORMAT, RECEIVE INPUT, DROP, and CHANNEL
- Changing the TEST switch from CONT. to TIMED
- Changing Auxiliary Function 03 (TES LEN) when the TEST switch is set to TIMED (See Section 2.5)
- Changing Auxiliary Function 07 (DS0 TIM) when the CHANNEL FORMAT switch is set to DS0 (See Section 2.5)

The **RESTART** switch selection causes a test restart which initializes and resets to zero:

- All results
- All LOCAL STATUS LEDs
- All HISTORY LEDs

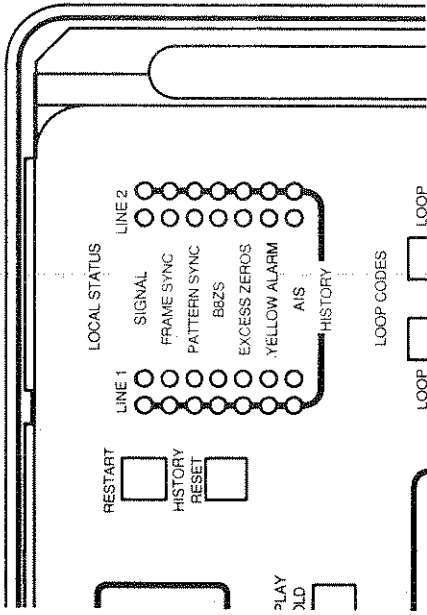

Figure 2-8
RESTART and HISTORY RESET Switches, LOCAL STATUS, and HISTORY LEDs

LOCAL STATUS and HISTORY LEDs [8]

Four columns of LEDs, two columns for LINE 1 and two columns for LINE 2, are used to indicate each T1 input's current status and history (see Figure 2-8). The two inside columns provide the current status of the incoming T1 signal (LOCAL STATUS LEDs) and the two outside columns display the status history (HISTORY LEDs). The LOCAL STATUS and HISTORY LEDs are color coded according to the function and condition to which they correspond. Green LEDs are used to indicate positive conditions (e.g., FRAME SYNC). Red LEDs are used to indicate history, alarm, or failure conditions (e.g., SIGNAL loss).

If DISPLAY HOLD is not enabled, press the **HISTORY RESET** switch [9] to clear the HISTORY LEDs. Each LOCAL STATUS LED illuminates for at least 100 ms when the corresponding condition is detected. This "on" time allows the user to observe transient occurrences that would otherwise occur too quickly for the user to detect. At the end of a timed test, all the status and alarm LEDs are frozen.

Using two LEDs for each status allows the following four conditions to be indicated:

Both LEDs off - No occurrence of the corresponding condition, past or present.

Only LOCAL STATUS LED on - The corresponding condition is presently occurring.

History LED on, LOCAL STATUS LED off - The corresponding condition occurred before but is not occurring now.

History LED on, LOCAL STATUS LED on - The corresponding condition is occurring now and has also occurred in the past.

The following list describes the LOCAL STATUS LEDs and the conditions under which they illuminate.

SIGNAL - This green status LED illuminates when a T1 signal with frequency equal to $1,544,000 \text{ Hz} \pm 5,000 \text{ Hz}$ and a level greater than -35 dBdsx is detected. The LED for the corresponding line (LINE 1 or LINE 2) indicates at which RECEIVE input (LINE 1 or LINE 2) the signal is detected.

SECTION 2

The red history LED illuminates when no signal is detected for a period of 150 ms at the respective line input connector.

FRAME SYNC - This green status LED illuminates when synchronization is achieved for the selected framing pattern within the received T1 data stream. The LED for the corresponding line illuminates to indicate at which RECEIVE input (LINE 1 or LINE 2) the frame synchronization is detected.

The red history LED illuminates when 2 out of 5 received frame bits are in error for the corresponding line.

PATTERN SYNC - On the standard T-BERD 224 the PATTERN SYNC LEDs are not functional. When the T1/Fractional T1/DDS Bit Error Rate Testing (BERT) Option is installed, the PATTERN SYNC LEDs indicate pattern synchronization when a selected test pattern is recognized. Refer to Section 13 for a complete description of the BERT Option capabilities.

B8ZS - The green status LED illuminates when B8ZS clear-channel codes are detected in the received T1 signal. The LED for the corresponding line (LINE 1 or LINE 2) illuminates to indicate on which line the B8ZS coding is detected.

The red history LED illuminates when the B8ZS code is no longer detected at the corresponding input.

NOTE: B8ZS codes can be detected regardless of the **CODE** switch setting.

EXCESS ZEROS - The red status LED illuminates when 16 or more consecutive zeros are detected. The LED for the corresponding line (LINE 1 or LINE 2) illuminates to indicate on which line the excess zeros are detected.

The red history LED illuminates when excess zeros are no longer detected at the corresponding input.

YELLOW ALARM - The red status LED illuminates when a yellow alarm is detected in the received T1 signal. The LED for the corresponding line (LINE 1 or LINE 2) illuminates to indicate on which line the yellow alarm is detected. Refer to Section 6.7.3 for yellow alarm specifications for each T1 framing format.

The red history LED is illuminated when yellow alarm is no longer detected at the corresponding input.

NOTE: Neither the status nor history LED illuminates for **YELLOW ALARM** if T1 frame synchronization has not been achieved.

AIS - The red status LED illuminates upon detection of an AIS signal (2048 consecutive unframed ones). The LED for the corresponding line (**LINE 1** or **LINE 2**) illuminates to indicate at which input the AIS signal is detected.

The red history LED illuminates when AIS is no longer detected at the corresponding input.

HISTORY RESET Switch [9]

The **HISTORY RESET** pushbutton switch (see Figure 2-8) extinguishes any **HISTORY** LEDs that are currently illuminated. Pressing this switch does not:

- Restart a test
- Affect any of the **LOCAL STATUS** LEDs that are currently illuminated
- Affect any accumulated test results

NOTE: This switch has no affect when **DISPLAY HOLD** is enabled.

LOOP CODES Switches [10]

The **LOOP UP** and **LOOP DOWN** pushbutton switches (see Figure 2-9) are not functional on a standard T-BERD 224. When either pushbutton switch is pressed, the message **OPTION NOT INSTALLED** flashes in the display.

When the BERT Option is installed, the **LOOP UP** switch controls the transmission of the loop-up code. The **LOOP DOWN** switch controls the transmission of the loop-down code. The LED within each switch illuminates for the duration of the loop code transmission.

SECTION 2

Refer to Section 13 for more information on these switches when the BERT Option is installed.

ABCD SIGNALING INSERT Switches [11]

The four **SIGNALING INSERT** pushbutton switches (see Figure 2-9) control the logic state of each signaling bit (A, B, C, and D) transmitted in the selected insert channel. The **SIGNALING INSERT** switches are only applicable when the **CHANNEL FORMAT** switch is set to **VF**. For each signaling bit, a logic 1 or 0 can be transmitted. Pressing the signaling switch illuminates the LED in the switch and causes a binary ONE to be inserted in the corresponding signaling bit position. Pressing the same signaling switch again extinguishes the LED and inserts a

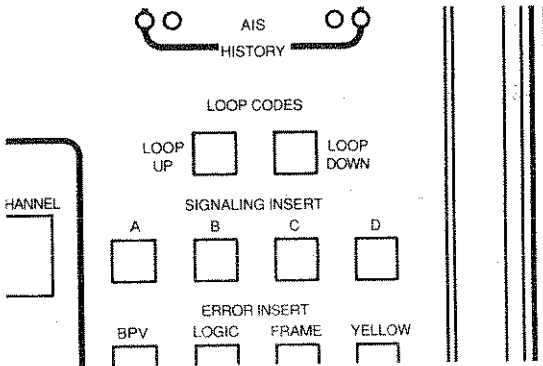

Figure 2-9

LOOP CODE AND SIGNALING INSERT Pushbutton Switches

binary ZERO into the corresponding bit position. The MODE selection determines which signaling bits are transmitted. The following list describes the signaling bits associated with each operating mode.

- T1-D1D - A and B signaling bits
- T1-D2 - A and B signaling bits
- D4 - A and B signaling bits
- SLC-96 - A and B signaling bits
- ESF - A, B, C, and D signaling bits
- ESFz (optional) - A, B, C, and D signaling bits

In T1 SLC-96, T1-D4, T1-D1D, or T1-D2 modes, the T-BERD 224 provides three signaling insert states: ON, OFF, and TOGGLING ON and OFF the A and B signaling bits. If either **SIGNALING INSERT** switch is OFF, pressing it once for less than a second turns the switch ON, sets the signaling bit to a logic 1, and illuminates the LED continuously. Pressing and holding in the switch for more than a second places the signaling bit in the TOGGLING state, as indicated by the **SIGNALING INSERT** switch LED flashing. In the TOGGLING state, the signaling bit toggles between logic 1 and logic 0 with every other superframe. Pressing the **SIGNALING INSERT** switch a second time inserts a logic 0 into the signaling bit and extinguishes the LED.

The **SIGNALING INSERT** switches are disabled and turned off when the **INSERT** switch is set to NONE. Modifying the **SIGNALING INSERT** switch selection does not affect the test in progress.

ERROR INSERT Switches [12]

The **ERROR INSERT** switches (see Figure 2-10) insert the corresponding errors BPVs, frame errors, or YELLOW alarms into the selected T1 line. An LED inside each switch illuminates to indicate when the error is inserted.

NOTE: The **INSERT** switch selects the T1 line for signal/error insertion. When the **INSERT** switch is set to NONE, the **ERROR INSERT** switches are disabled.

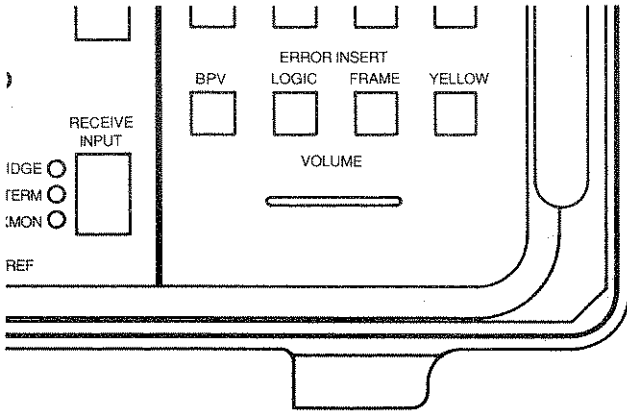

Figure 2-10
ERROR INSERT and VOLUME Switches

The **ERROR INSERT** switches perform the following functions:

BPV ERROR INSERT Switch — This switch inserts one BPV into the data stream of the selected T1 line and momentarily illuminates the **BPV ERROR INSERT** switch LED each time it is pressed. The BPV is inserted on any transmitted logic one bit, including the framing bits.

LOGIC ERROR INSERT Switch — This switch is only available with the T-BERD 224 BERT Option. If the BERT Option is not installed and this switch is pressed, the message **OPTION NOT INSTALLED** flashes in the display. Refer to Section 13, BERT Option, for more information.

FRAME ERROR INSERT Switch — This switch inserts one frame error into the transmitted framing bits (i.e., the Ft bits in D1D, D2, D4, and SLC-96 and the frame pattern bits in ESF and ESFz (optional)) in the data stream of the selected T1 line and momentarily illuminates the **FRAME ERROR INSERT** switch LED each time it is pressed.

NOTE: The **FRAME ERROR INSERT** switch has no effect when the T-BERD 224 has not synchronized to the incoming framing format.

YELLOW ALARM ERROR INSERT Switch — This switch inserts a continuous yellow alarm into the selected T1 line and momentarily illuminates the **YELLOW ALARM ERROR INSERT** switch LED the first time it is pressed. Pressing this switch again disables the yellow alarm insertion and extinguishes the switch LED. For D1D, D2, D4, and SLC-96 framing, Bit 2 of every DS0 is set to zero. For ESF and ESFz (optional) framing, a repetitive pattern of eight ones and eight zeros (1111 1111 0000 0000) is generated in the datalink.

NOTE: The **YELLOW ALARM ERROR INSERT** switch has no effect when the T-BERD 224 has not synchronized to the incoming framing format.

When the BERT Option is installed, the **ERROR INSERT** switch capabilities are expanded to include single, burst, and continuous BPV, logic, and frame error insertion. To verify that the BERT Option is installed, press the **LOGIC ERROR INSERT** switch. If the message **OPTION NOT INSTALLED** does not appear, then the option is installed and logic errors are inserted into the signal. Refer to Section 13.3.7, Error Insert Switches, for the BERT Option capabilities.

NOTE: The **YELLOW ALARM ERROR INSERT** switch continues to function as previously described.

VOLUME Switch [13]

The **VOLUME** switch (see Figure 2-10) adjusts the audio level of the T-BERD 224 internal speaker used while listening to a dropped channel's voice or signal. Sliding the switch from left to right increases the volume, while sliding it from right to left decreases the volume. The speaker volume can also be muted through remote control.

If the BERT Option is installed, an audible beep occurs when specific conditions (e.g., logic errors are received) happen. Refer to Section 13.3.11, Audible Indicator, for additional information.

CHANNEL Switches [14]

The **LINE 1** and **LINE 2 CHANNEL** switches (see Figure 2-11) select a channel to be monitored or tested. The selected channel number is visible in the dual seven-segment **CHANNEL** display next to each

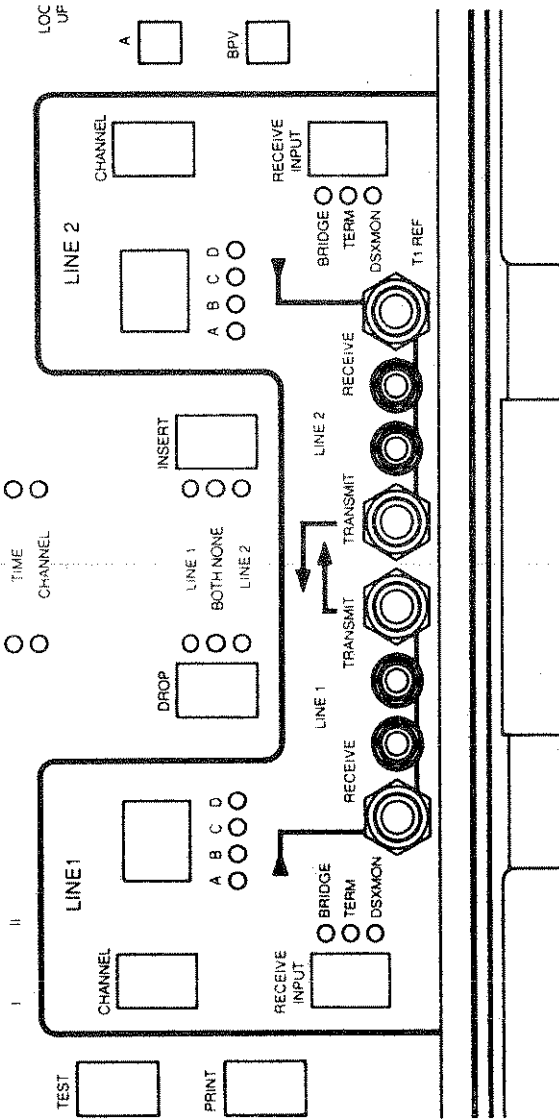

Figure 2-11
CHANNEL, RECEIVE INPUT, INSERT and DROP Switches

switch. Pressing the up arrow increments the displayed channel number; pressing the down arrow decrements the displayed channel number. If either **CHANNEL** switch is pressed and held for more than 1 second, the channel numbers scroll continuously until the switch is released.

LINE 1 or 2 CHANNEL switch selections are:

1 to 24 — Selects the displayed channel number for testing and analysis.

ALL — Allows the displayed BYTE or 1004 Hz tone to be inserted within all (1-24) channels when the **INSERT** switch is set to the corresponding line. Available only when **SC1** switch is set to BYTE or 1004 Hz. When **SC1** is set to DROP CHAN and ALL is selected for the line being dropped, time slot 1 is dropped.

When the **INSERT** switch is set to LINE 1 or 2, modifying the corresponding **LINE 1 or 2 CHANNEL** switch selection causes the T-BERD 224 to stop inserting data or tones as designated by the **SC1** and **SC2** switches until 3 seconds after the switch is released. Modifying either **CHANNEL** switch selection causes a test restart.

A, B, C, and D SIGNALING STATUS LEDs [15]

These amber LEDs illuminate to indicate the received signaling bit states for the channel indicated by the **CHANNEL** switch for each line, LINE 1 or LINE 2. When the LED is illuminated the corresponding signaling bit is a logic 1 and when the LED is extinguished, the signaling bit is a logic 0. These LEDs are only active for VF and VF THRU channel formats.

RECEIVE INPUT Switches [16]

The **LINE 1** and **LINE 1 RECEIVE INPUT** switches (see Figure 2-11) are 3-position switches that determine the input impedance and signal conditioning for the corresponding receiver. Modifying the **RECEIVE INPUT** switch selection causes a test restart. **RECEIVE INPUT** switch selections are:

BRIDGE — When the receive input is set to BRIDGE, greater than 1000 ohms input impedance is provided. This input should be

SECTION 2

selected when the line monitored is already properly terminated. ALBO (Automatic Line Build-Out) compensation is provided when BRIDGE is selected. ALBO automatically adjusts for up to 35 dB of cable loss.

TERM — When the receive input is set to TERM, 100 ohms input impedance is provided. This input should be selected when the line monitored is terminated by the T-BERD 224. ALBO compensation is provided when TERM is selected. ALBO automatically adjusts for up to 35 dB of cable loss.

DSX MON — When the receive input is set to DSX MON, 100 ohms input impedance is provided and the incoming signal is amplified to compensate for resistive attenuation. DSX MON is useful when monitoring signals at DSX monitoring points which are resistor-isolated.

INSERT Switch [17]

The **INSERT** switch (see Figure 2-11) selects the T1 line in which the channel data and errors are inserted. The illuminated LED to the left of the **INSERT** switch indicates the T1 line in which data is inserted. **INSERT** switch selections are:

LINE 1 — Selects LINE 1 as the location where the data and errors are inserted.

NONE — (Default) Selects neither line for data insertion.

LINE 2 — Selects LINE 2 as the location where the data and errors are inserted.

NOTE: After a power loss, the **INSERT** switch is always reset to NONE.

When LINE 1 or LINE 2 is selected, the signals specified in the SOURCE CONFIGURATION I and II displays are inserted into the channels specified with the associated **CHANNEL** switch. If the T-BERD 224 is acting as the T1 signal source, the channel data (selected using **SCI** and **SCII** switches) is inserted into the designated channel(s) (selected by the **LINE 1** and **LINE 2 CHANNEL** switches). A framed all ones pattern (1111 1111) is transmitted within the other channels. The T1 data clock is provided, as defined in AUX 06 Backup Timing Source function.

NOTE: No T1 signal is present at the receiver of the line selected by the **INSERT** switch when the T-BERD 224 is acting as the T1 signal source.

Modifying the **INSERT** switch from **NONE** to **LINE 1** or **LINE 2** inserts data, as well as user-selected errors and signaling bits (if applicable), 3 seconds after the switch is released. During this 3-second delay, the selected channel number flashes in the **CHANNEL** switch display. Changing the **MODE**, **CHANNEL FORMAT**, **SCI** and **SCII**, **INSERT**, and **CHANNEL** switches for the line being inserted on (**LINE 1** or **LINE 2**) also cause the insertion to be reset and re-enabled after 3 seconds.

NOTE: Modifying the **INSERT** switch from **LINE 1** or **LINE 2** to **NONE** immediately aborts the insert function.

DROP Switch [18]

The **DROP** switch (see Figure 2-11) selects the T1 line(s) from which a channel(s) is to be dropped for testing. The illuminated LED to the right of the **DROP** switch indicates the T1 line source(s). **DROP** switch selections are:

LINE 1 — Selects **LINE 1** as the source from which the data is dropped.

BOTH — Selects both lines as the source to be dropped. If **BOTH** is selected and **DS0** is the selected **CHANNEL FORMAT**, then only **LINE 1** is dropped to the selected side-panel interface. Channel results such as received byte are still available for both lines.

LINE 2 — Selects **LINE 2** as the source from which the data is dropped.

NOTE: Modifying the **DROP** switch selection causes a test restart.

TEST Switch [19]

The **TEST** switch (see Figure 2-12) is a 2-position switch that controls test duration. The **CONT.** (continuous) position enables unlimited test duration. The **TIMED** position enables the user to conduct a timed test of up to 200 hours, 59 minutes, 45 seconds.

SECTION 2

NOTE: Changing from continuous (CONT.) to timed (TIMED) causes a test restart and the message SEE AUX 03 TO SET TEST LENGTH is momentarily displayed in the right-most window. However, changing from timed (TIMED) to continuous (CONT.) allows the test to continue (i.e., test results continue to accumulate).

PRINT Switch [20]

The **PRINT** switch (see Figure 2-12) is a 2-position, momentary rocker switch that initiates either a results printout or a controls printout to be output to the printer interface. For more information regarding printouts, refer to Section 5.3.

RESULTS — Pressing the switch to this position generates a date- and time-stamped printout of current test results.

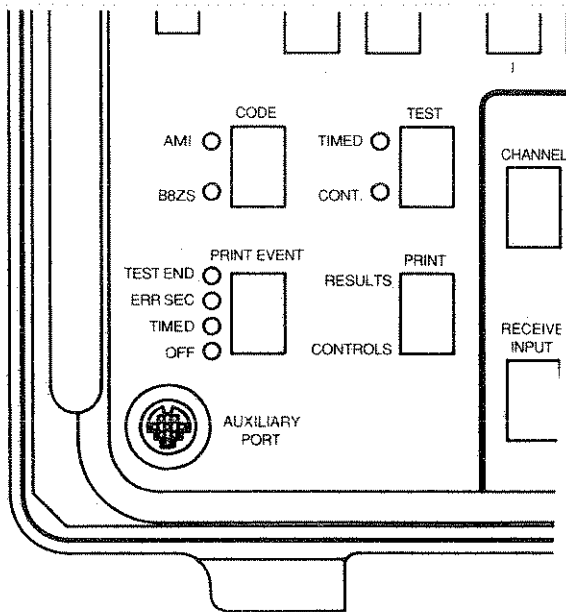

Figure 2-12
TEST, PRINT, PRINT EVENT, and CODE Switches

CONTROLS — Pressing the switch to this position generates a date- and time-stamped printout of the current configuration of the T-BERD 224.

PRINT EVENT Switch [21]

The **PRINT** switch (see Figure 2-12) selects the event that causes an automatic results printout to be generated. Pressing the switch steps through the print events and illuminates the LED corresponding to the selected print event. All of the print event selections, except for **OFF**, cause a status message to print if an alarm condition changes. A list of all the status messages is found in Section 5.3.4

TEST END — This selection causes a time- and date-stamped results printout to be generated at the end of a timed test if the **TEST** switch is set to **TIMED**. The AUX 03 TES LEN function is used to set the timed test length.

ERR SEC — This selection causes a time- and date-stamped results printout to be generated on the occurrence of a BPV, frame error, or CRC error for either **LINE 1** or **LINE 2**.

TIMED — This selection causes a time- and date-stamped results printout to be generated when the specified time interval is completed. When **TIMED** is first selected, the message SEE AUX 02 TO SET PRI EVENT TIME is displayed in the right-most window. The AUX 02 TIM PRI function is used to set the timed print event. The default for this function is 6.0 hours.

OFF — This selection prevents automatic results print information from being generated. This selection does not affect the **PRINT** switch operation.

The T-BERD 224 has a built-in squelch feature to prevent excessive error printouts. In the event that 20 or more error events (including alarms) occur within any 60-second period, the 20th printout is stamped with a message indicating that the squelch feature is being enabled. The squelch feature is enabled until 5 or fewer errors are detected in a 60-second interval. When this condition is met, another printout is generated with a message indicating that the squelch feature is disabled, and a results print is generated. The squelch can be disabled manually

SECTION 2

through Auxiliary Function 01 (CL FIFO). For information on disabling the automatic squelch feature while in remote control, refer to Section 6.

CODE Switch [22]

The **CODE** switch (see Figure 2-12) is a 2-position switch that determines the type of line coding the T-BERD 224 uses when transmitting a T1 signal for either LINE 1 and/or LINE 2. The LEDs to the left of this switch illuminate to indicate which type of coding is selected.

AMI — When this position is selected, alternate mark inversion (AMI) coding is used for data transmission and the LED next to the AMI label is illuminated.

B8ZS — When this position is selected, clear channel (bipolar with 8 zero substitution) coding is selected for transmission and the LED next to the B8ZS label is illuminated. Note that when receiving a T1 signal, B8ZS decoding is automatic, regardless of the **CODE** switch selection, so that erroneous test results are avoided.

2.4 CONNECTIONS

The following paragraphs describe the connectors and the signals present at the connectors on the front panel and the side panel. The numbers in brackets following the connector names correspond to the numbers in Figures 2-13, 2-14, and 2-15.

2.4.1 Front Panel Connections

TRANSMIT Jacks [1]

There are two front panel TRANSMIT jacks for each line (see Figure 2-13): one WECO 310 and one bantam. Either of these connectors may be used to provide a transmit output. Before being applied to the output, the transmitted signal is passed through a switchable line

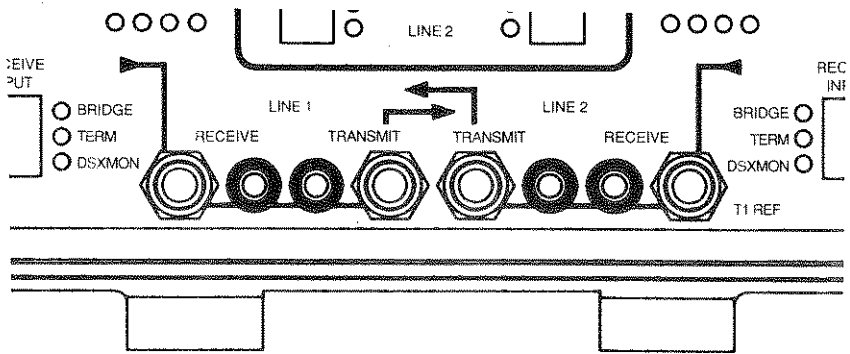

Figure 2-13
T-BERD 224 Front Panel Connector Locations

build-out circuit. The setting for AUX 05 LBO function determines the amount of line build-out (0 dB, -7.5 dB, or -15 dB) inserted at 772 kHz to present a DSX-level output. Refer to Section 2.5 for more information on Auxiliary Function 05.

RECEIVE Jacks [2]

There are two front panel RECEIVE jacks for each line (see Figure 2-13): one WECO 310 and one bantam. Either of these connectors may be used to accept a T1 signal input. The **RECEIVE INPUT** switch setting (BRIDGE, TERM, or DSX MON) determines the input impedance the T-BERD 224 applies to the received signal.

NOTE: When performing T1 timing slip analysis, a LINE 1 RECEIVE jack can be used as an input. The reference clock source must be connected to either the LINE 2 RECEIVE jack or to the side panel BNC connector.

AUXILIARY PORT Connector [3]

The AUXILIARY PORT 8-pin connector (see Figure 2-14) provides the serial data port that supplies power and signaling leads to the optional lid printer. It is connected in parallel to the RS-232 Printer/Controller Interface, allowing data to be directed to either the side panel or front panel connector. The T-BERD 224 polls the connectors to determine which one has a device connected to it before initiating a printout.

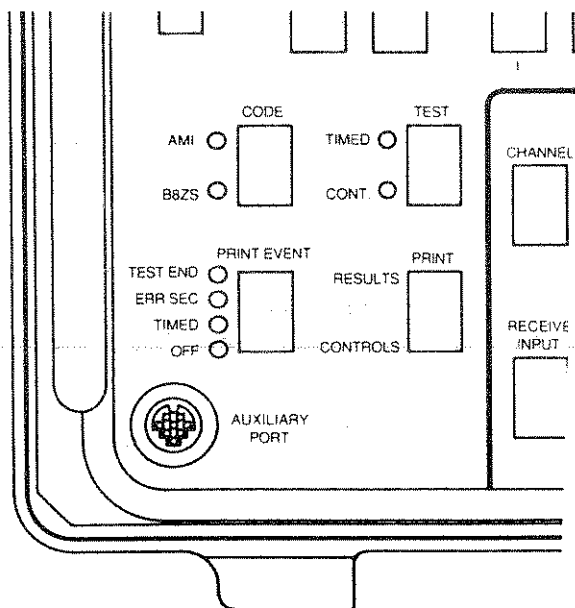

Figure 2-14
AUXILIARY Port Connector

2.4.2 Side Panel Connections

The following sections provide information on each of the side panel connectors. The numbers in brackets following the connector names correspond to the numbers in Figure 2-15.

SECTION 2

PRINTER/REMOTE RS-232 Connector [1]

The PRINTER/REMOTE RS-232 connector is a 25-pin, female, D-type connector (see Figure 2-15). It is configured as data communications equipment (DCE) to connect the T-BERD 224 to an external printer, terminal, modem, computer, or other asynchronous communications equipment. The AUX 08 RS 232 function provides the setups for this interface.

NOTE: A DTE/DCE crossover cable may be required to operate the T-BERD 224 with an external modem. For information about the RS-232 connector pin assignments, refer to Section 6.

DS0 INTF Jacks [2]

The DS0 INTF (interface) provides external access to bipolar, 64 kb/s, DS0 within the T1 bit stream data. Two bantam jacks provide the data connection. The transmit input (TX IN) jack is used to insert a 64 kb/s DS0 signal source into a channel designated by the front panel **INSERT** and **CHANNEL** switches. The 64 kb/s DS0 signal dropped from the T1, as designated by the front panel **DROP** and **CHANNEL** switches, is output at the receive output (RX OUT) jack. These jacks are commonly used by external KS-type test sets for testing DDS circuits from a T1 access point. This interface is electrically identical to DS0-DP interfaces on channel bank cards.

DS0 CLK Connectors [3]

The DS0 CLK (DS0 Interface Clock) connectors are two male, 9-pin, D-type connectors that provide the 8 kHz byte and 64 kHz bit clocks. Pin 1 of these connectors provides a regulated 5V at a maximum of 100 mA. The clock connectors may be synchronized or independent as determined by AUX 07 DS0 TIM function which is described in Section 2.5.

TEST PTS. Connector [4]

The 37-pin D-type TEST PTS. connector provides TTL access to 22 test points. The test points are divided into LINE 1 and LINE 2,

have a one-to-one correspondence to the front panel indicators, and can be used as a trigger for external equipment when alarm conditions occur. Test point signals include:

LINE n FRAME SYNC - This test point is a logic high when the T-BERD 224 gains frame synchronization to the respective line (LINE 1 or LINE 2) input.

LINE n BPV - This test point is a logic low when a bipolar violation is detected for the respective line input. Note that B8ZS codes do not cause this indicator to be a logic low.

LINE n CRC ERROR - This test point is a logic high when a CRC error (ESF or ESFz) is detected in the respective line input.

LINE n AIS - This test point is a logic low when an Alarm Indication Signal (2048 or more consecutive unframed ones) is detected in the respective line input.

LINE n YELLOW ALARM - This test point is a logic high when a yellow alarm is detected in the respective line input.

LINE n SIGNALING BIT - These test points provide access to a dropped channel's ABCD signaling bits for each line.

INSERT SIGNALING BIT - These test points provide control of an inserted channel's ABCD signaling bits for the line indicated by the **INSERT** switch. Note that pin 10 must be connected to ground before signaling inputs are accepted from the test points.

For information regarding the test point connector's pin designations, refer to Section 7.

4-WIRE VF Interface Jacks [5]

Two WECO 310 jacks, with 600-ohm termination, provide 4-wire VF interface access to a digitally encoded VF channel. This interface allows analog VF test sets, which were traditionally only used at analog test points, to have access to VF information at a T1 access point. The 4-wire VF interface converts analog signals present at the input connector into digital signals suitable for transmission on the T1 span. VF channels from the digital T1 bit stream are converted into analog VF signals at the output connector.

SECTION 2

NOTE: When the **DROP** switch is set to **BOTH**, two channels are output to the side panel interface.

VF 2-WIRE INTF Terminals [6]

These two turret-type posts provide 2-wire test access to a digitally encoded VF channel. Using an external butt-in set, users can connect to the 600-ohm terminated interface to dial DTMF digits and talk to an intended party.

EXTERNAL BNC CLOCK Connector [7]

This bayonet connector provides an AC-coupled input impedance of 75 ohms for an external T1 clock source. This backup clock source can be selected via AUX 06 BACK TM function, described in Section 2.5). The BNC external T1 clock source may also be used to provide the reference clock source for measuring timing slips.

AC Power Connector [8]

The unit's power cord is plugged into this receptacle to provide line voltage to the unit. The T-BERD 224 is factory-configured for 115 VAC or 230 VAC operation. The safety ground connection is wired directly to the T-BERD 224 chassis. The line fuse compartment, located directly below the power receptacle, contains a spare fuse.

WARNING: Ground the instrument. In order to minimize shock hazard, the instrument chassis must be connected to an electrical ground. This unit is equipped with a three-conductor AC power cable. The power cable must either be plugged into an approved three-contact electrical outlet or used with a three-contact to two-contact adaptor with the grounding wire (green) firmly connected to an electrical ground (safety ground) at the power outlet.

CAUTION: The T-BERD 224 should be operated with a 1 Amp, 250 V, SLO-BLO fuse installed (Littlefuse type #218001, or its equivalent). Always use the correct fuse rating.

The AC Line Fuse compartment is located between the AC Power connector and the AC Power Switch. A spare fuse is located inside the fuse module.

AC Power Switch [9]

The **AC Power** switch is located above the AC receptacle and fuse holder. The **AC Power** switch is marked with a "1" for the ON position and a "0" for the OFF position.

2.5 AUXILIARY FUNCTIONS

When the auxiliary functions are enabled, the right switch of the front panel switch pairs (**SCI** and **SCII**, and **RESULTS I** and **RESULTS II**) is used to modify the auxiliary parameter in the window directly above the corresponding switch. To access the auxiliary functions, press the front panel **AUX** switch and illuminate the LED inside the switch. Use the **MODE** switch to scroll through the available auxiliary functions.

The auxiliary function settings, as well as the front panel switch settings, are stored in NOVRAM. Pressing the **RESTART** switch momentarily during power up causes all NOVRAM to be loaded with initial factory settings and resets all the front panel switches and auxiliary functions to their default settings. Refer to Appendix A for a list of the default settings.

The following paragraphs provide information on each of the auxiliary functions, including an example of the display and a description of the auxiliary function application procedure.

AUX 01 CL FIFO — Clear Print FIFO Buffer

AUX 01	CLEAR PRINT FIFO
CL FIFO	YES? PRESS SRC CONFIG 2 SWITCH



SECTION 2

CL FIFO allows the user to clear the print FIFO when the **SCII** switch is pressed. Pressing the **SCII** switch resets the printer squelch feature and flashes the message FIFO CLEARED in the display.

AUX 02 TIM PRI — Set Timed Print Event Duration

AUX 02	TIMED PRINT EVENT		
TIM PRI	6 HRS	00 MIN	00 SEC

MODE	FORMAT CHANNEL	SCI	SCII	RESULTS I	RESULTS II
<input type="checkbox"/>	<input type="checkbox"/>	<input type="checkbox"/>	<input type="checkbox"/>	<input type="checkbox"/> <input type="checkbox"/>	<input type="checkbox"/> <input type="checkbox"/>

TIM PRI allows the user to select the time interval for results printouts when the **PRINT EVENT** switch is set to **TIMED**. The timed interval can vary from 15 seconds up to 6 hours. The default setting is 6 hours and 0 minutes. Use the **SCII** switch to set the hours, the **RESULTS I Category** switch to set the minutes, and the **RESULTS II Results** switch to set the seconds.

AUX 03 TES LEN — Set Timed Test Length Duration

AUX 03	TIMED TEST LENGTH		
TES LEN	200 HRS	00 MIN	00 SEC

MODE	FORMAT CHANNEL	SCI	SCII	RESULTS I	RESULTS II
<input type="checkbox"/>	<input type="checkbox"/>	<input type="checkbox"/>	<input type="checkbox"/>	<input type="checkbox"/> <input type="checkbox"/>	<input type="checkbox"/> <input type="checkbox"/>

TES LEN allows the user to select the time interval for a timed test. A timed test is performed when the **TEST** switch is set to **TIMED**. The timed interval can vary from 15 seconds up to 200 hours, 59 minutes, and 45 seconds. The default setting is 200 hours, 00 minutes, and 00 seconds. Use the **SCII** switch to set the hours, the **RESULTS I Category** switch to set the minutes, and the **RESULTS II Results** switch to set the seconds.

NOTE: Changing the test length causes a test restart when the **TEST** switch is set to **TIMED**.

AUX 04 TIM/DAY — Set Clock Time and Date

AUX 04	CLOCK TIME and DATE		
TIM/DAY	12 HRS	0 MINS	JAN 1



TIM/DAY allows the user to set the real-time clock and calendar date. For setting the real-time clock, the **SCII** switch sets the hour and the **RESULTS I Category** switch sets the minutes. The default time is 12 hours and 00 minutes (noon) based on a 24-hour (military) clock.

NOTE: The time is updated as long as the front panel switches are not being pressed to set the time.

For setting the calendar date, the **RESULTS II Results** switch sets the month and the **RESULTS II Results** switch sets the day. The default date is JAN 1.

AUX 05 LBO — Set Line Build-Out Level

AUX 05	LINE 1	LINE 2	
LBO	0 dB	-15 dB	

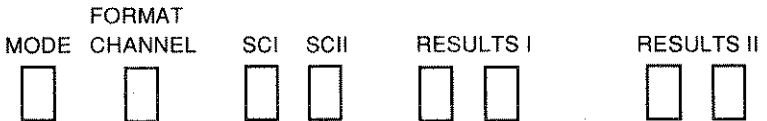

LBO allows the user to emulate one of three different cable losses for LINE 1 and LINE 2 transmitted outputs. The **SCII** switch sets the line build-out for Line 1 and the **RESULTS I Category** switch sets the line build-out for Line 2. The choices for line build-out are 0 dB (default), -7.5 dB, and -15 dB.

SECTION 2

AUX 06 BACK TM — Set Backup Timing Source

AUX 06 BACK TM	BACKUP TIMING SOURCE INTERNAL
-------------------	----------------------------------

MODE	FORMAT CHANNEL	SCI	SCII	RESULTS I	RESULTS II
<input type="checkbox"/>	<input type="checkbox"/>	<input type="checkbox"/>	<input type="checkbox"/>	<input type="checkbox"/> <input type="checkbox"/>	<input type="checkbox"/> <input type="checkbox"/>

BACK TM allows the user to select which backup transmit timing source (EXTERNAL or INTERNAL) is used for LINE 1 and LINE 2 transmitter if no input is available for the respective line. As long as a clock is recoverable from a line's received input, this auxiliary function is ignored. However, if the input clock is lost for a line, then this auxiliary function determines the timing source for that line. Pressing the SCII switch selects the backup timing source.

EXTERNAL - Selects the EXT BNC connector, located on the right side panel, as the backup transmit timing source. If no timing source is connected to the EXT BNC connector, a message EXT CLOCK LOSS is flashed in the results display indicating that no transmit timing source is present at the connector.

INTERNAL (default) - Selects the fixed, internal, crystal oscillator (operating at a nominal T1 rate) as the backup transmit timing source.

AUX 07 DS0 TM — Set DS0 Interface Timing

AUX 07 DS0 TM	DS0 INTERFACE TIMING COMMON
------------------	--------------------------------

MODE	FORMAT CHANNEL	SCI	SCII	RESULTS I	RESULTS II
<input type="checkbox"/>	<input type="checkbox"/>	<input type="checkbox"/>	<input type="checkbox"/>	<input type="checkbox"/> <input type="checkbox"/>	<input type="checkbox"/> <input type="checkbox"/>

DS0 TM allows the user to control the DS0 interface transmit and receive clocks. Note that if the CHANNEL FORMAT switch is set to DS0, changing this selection causes a test restart. The SCII switch is used to select between:

COMMON (default) - Configures the two side panel DS0 clock connectors to provide identically phased clocks. Used when no timing slips are occurring between the two T1 inputs.

SEPARATE - Configures each side panel DS0 clock connector to be individually synchronized to its respective T1 clock signal source. Used when timing slips are occurring between the two T1 inputs.

NOTE: Two external DS0 test sets are required when SEPARATE is selected since the transmit bit and byte clocks are not in phase with the received bit and byte clocks.

AUX 08 RS 232 — Set PRINTER/REMOTE RS-232 Connector Configuration

AUX 08	PARITY	BAUD	TERMINATOR
RS 232	NONE	9600	CR



RS-232 allows the user to select the parity, baud, and line terminator for the side panel's RS-232 printer/remote control port, as follows:

PARITY - The parity selection determines the parity used for RS-232 data transmission. The RS-232 interface parity can be set to NONE (default), EVEN, or ODD. Use the **SCII** switch to select the desired parity.

NOTE: When PARITY is set to NONE, data is sent using 8 bits and when it is set to ODD or EVEN, data is sent using 7 bits.

BAUD - The RS-232 printer/remote interface baud rate can be set to 300, 1200, 2400, 4800, or 9600 (default). Use the **RESULTS I Category** switch to select the desired baud rate.

TERMINATOR - The terminator is used to select the terminating character for the printer/remote interface. Available terminating characters are: CR (default), LF, or CRLF. Use the **RESULTS II Results**

SECTION 2

switch to select the desired terminating character. The default termination character is CR, allowing the test set to operate with an optional lid printer, as well as the portable PR-40A printer.

2.6 MEASUREMENTS

The T-BERD 224 PCM Analyzer performs a variety of measurements. These measurements are divided into six different categories:

- SUMMARY
- LOGIC
- BPV & FRAME
- SIGNAL
- TIME
- CHANNEL

These six categories and the results available for each are discussed in the following paragraphs. The display window above the **RESULTS** switches is used to provide a visual indication of the selected results. The top line provides the result number and the result name, and the bottom line provides the result count or value.

NOTE: Results are numbered using an nXX format where n = the line number (1 for LINE 1 and 2 for LINE 2) and XX = the result number. For example, result 125 BPVs indicates the number of BPVs detected on LINE 1 input and result 225 BPVs indicates the number of BPVs detected on LINE 2 input.

2.6.1 SUMMARY Category

This category allows key non-zero and out-of-specification results to be quickly viewed without having to scroll through several result categories. If a signal is detected and no errors are counted, the message "RESULTS OK" is displayed. If no signal has been detected, the message "RESULTS UNAVAIL" is displayed. Table 2-3 lists the results in this category.

Table 2-3
SUMMARY Results Category

Result Name	Description	For Further Information
n25 BPVS	Bipolar Violations >0	See BPV & FRAME
n30 FRM ERR	Frame Errors >0	See BPV & FRAME
n32 CRC ERR	CRC Errors >0	See BPV & FRAME
n34 FRM LOS	Frame Losses >0	See BPV & FRAME
n40 RX FREQ	Receive Frequency: 1,544,000 Hz \pm 77 Hz	See SIGNAL
n51 TM SLIP	Timing Slips: \pm Frame Slip	See SIGNAL

POWER LOSS — This message is displayed at power-up if the power has been turned off or when power to the unit has been interrupted. This message is cleared when a test restart is performed.

RESULTS OK — This message is visible in the results display if the SUMMARY results have a zero value (BPVs, FRM ERR, CRC ERR, FRM LOS) or are within specifications (RX FREQ, TM SLIP).

2.6.2 LOGIC Category

This category is only available when the BERT Option is installed. If the BERT Option is not installed and the category is selected, OPTION NOT INSTALLED flashes in the display. When the BERT Option is installed, the Logic Category provides a number of logic results. Refer to Section 13, BERT Option, for a full description of the available logic results.

2.6.3 BPV & FRAME Category

This category can be used when monitoring T-Carrier spans that are transmitting live traffic or test patterns. Table 2-4 describes the specific results available.

Table 2-4
BPV & FRAME Results Category

Result Name	Description
n25 BPVS	Bipolar Violations. A count of BPVs since the start of elapsed time (excluding intentional violations found within B8ZS codes).
n26 BPV SEC	Bipolar Violation Seconds. The number of seconds within which one or more BPVs occurred since the start of elapsed time.
n27 BPV RT	Bipolar Violation Rate. The ratio of BPVs to the number of data bits received.
n28 FRM ES	Frame Errored Seconds. A count of seconds during which one or more frame errors occurred.
n29 FRM SES	Frame Severely Errored Seconds. A count of seconds during which the total number of frame errors equaled 12 or more (D4 framing only).
n30 FRM ERR	Frame Errors. A count of frame errors detected since initial frame sync. For D1D, D2, and D4 (Superframe) frame errors are counted if either an F_1 or F_s frame bit is errored. For SLC-96 framing, frame errors are counted if F_1 bits are errored. For ESF and ESFz (optional) framing, frame errors are counted only if an error is found on the frame bits. Frame errors are not detected on CRC or data link bits.
n31 FRM ERT	Frame Error Rate. The ratio of frame errors to the number of analyzed framing bits. For D1D, D2, and D4 framing, the Frame Error Rate is the ratio of frame errors to the number of F_1 and F_s bits, and for SLC-96 it is the ratio of frame errors to the number of F_1 bits. For ESF and ESFz (optional) framing the Frame Error Rate is the ratio of frame errors to the frame bits analyzed.
n32 CRC ERR	CRC Errors. A count of CRC errors detected since initial frame sync. CRC errors are counted only when ESF or ESFz (optional) framing is detected in the received T1 data.

Table 2-4
BPV & FRAME Results Category (Continued)

Result Name	Description
n33 CRC ES	CRC Errored Seconds. A count of seconds within which one or more CRC errors are detected.
n34 FRM LOS	Frame Losses. A count of discrete losses of frame synchronization since initial frame synchronization.
n35 FR LS S	Frame Loss Seconds. A count of seconds within which frame synchronization was lost or could not be achieved since initial frame synchronization. This includes seconds when a signal loss causes a frame synchronization loss.
n36 CRC SES	CRC Severely Errored Seconds. A count of seconds during which the total number of CRC errors and frame synchronization losses equaled 320 or more.
n37 CRC ERT	CRC Error Rate. The ratio of CRC errors to the number of extended superframes received.

2.6.4 SIGNAL Category

This category is used for analyzing the input signal's characteristics. Table 2-5 describes the specific results available.

Table 2-5
SIGNAL Results Category

Result Name	Description
n40 RX FREQ	Receive Frequency. The frequency of the clock recovered from the received data.
n41 RX LVL	Receive Level (in dBdsx). The level of the received signal in dB, relative to a standard 3-volt base-to-peak signal (DSX level).
n42 RX LVL	Receive Level (in dBm). The power level of an unframed all-ones signal (available only when AIS is detected).

SECTION 2

Table 2-5
SIGNAL Results Category (Continued)

Result Name	Description
n43 RX LVL	Receive Level (in V p-p). The level of the received signal in peak-to-peak volts. The signal level is displayed as volts (V) when the signal level is greater than 1 volt or as millivolts (mV) when the signal level is less than 1 volt.
n51 TM SLIP	Timing Slips. The frequency deviation of uncontrolled clock slips between two input signals measured in positive or negative shifts in bit and frame positions.
n52 SLP SEC	Slip Analysis Seconds. A count of test seconds during which Timing Slip Analysis occurred.
55 TRAFFIC	Traffic Results. A display of the A and B signaling bits for all 24 channels of LINE 1 and LINE 2. Scrolling to this result causes the entire VF display (both lines) to show the signaling bit states for each line's 24 channels in 4 fields, 6 channels at a time (1-6, 7-12, 13-18, and 19-24).
n56 TRAFFIC	<p>Traffic Results (For ESF and ZBTSI (optional) framed signals). A display of the A, B, C and D signaling bits for all 24 channels of LINE 1 and LINE 2. Scrolling to this result causes the entire VF display (both lines) to show the signal states for either line's 24 channels in 4 fields, 6 channels at a time (1-6, 7-12, 13-18, and 19-24).</p> <p>NOTE: Whenever a TRAFFIC result is displayed, the entire display window is used. In order to return to a "normal" display, the corresponding RESULTS category or Results switch must be pressed to exit the TRAFFIC display.</p>

Timing Slips Measurement (n51 TM SLIP)

The T-BERD 224 timing slips measurement (n51 TM SLIP) identifies frequency deviations that cause uncontrolled clock slips. When measuring timing slips, a received T1 signal (LINE 1) is compared to a reference T1 clock connected to the T1 REF input (LINE 2) or to the side panel BNC

connector. If a T1 clock reference is attached to the side panel BNC connector, timing slip analysis is performed for both LINE 1 and/or LINE 2. The T-BERD 224 compares the T1 test signal(s) with the reference and counts the number of times that the clock edge of the received signal moves past the edge of the reference signal, as indicated in Figure 2-16.

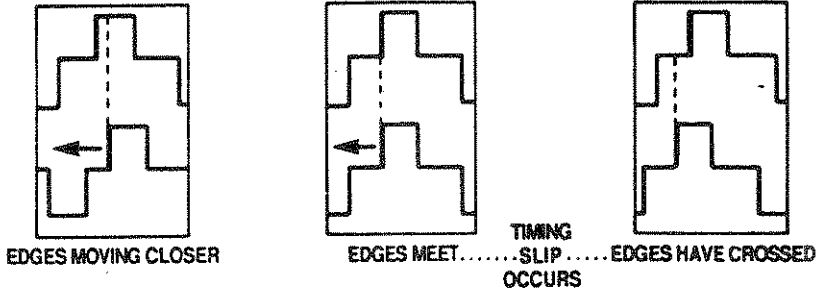

Figure 2-16
Timing Slips

The n51 TM SLIP result (available in the SUMMARY and SIGNAL results categories) is displayed in three discrete portions, as illustrated in Figure 2-17. These three portions are:

- A numeric value
- A bar graph
- A moving “wheel”

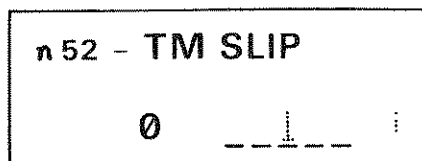

Figure 2-17
Timing Slips Results Display

SECTION 2

The numeric value is a range between 0 and 999. This value represents the total number of frame slips that have occurred. One frame slip is equal to 193 bit-slips.

The bar graph represents partial frame slips. These partial slips are represented in increments of one bar for every 16-bit slips (one wheel rotation). Each time the bar moves to the end of the graph, it is reset to the middle position and the frame slip count is incremented.

The wheel is used along with the bar graph to graphically display the direction, rate, and magnitude of timing slips. Figure 2-18 shows the values assigned to each position of the bar graph and the wheel.

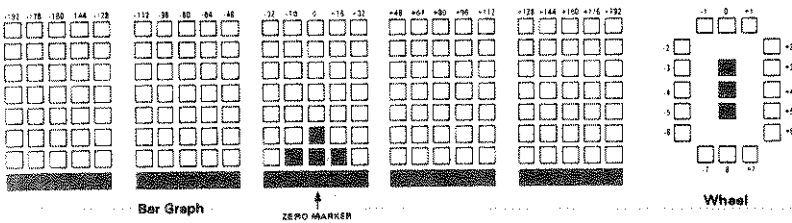
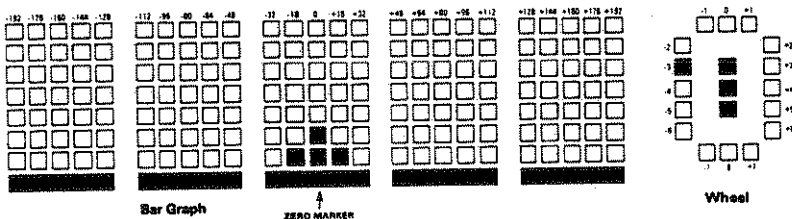

Figure 2-18
Bar Graph and Wheel Values

The magnitude of a timing slip is determined by adding the magnitude of the number indicated by the wheel's position to the corresponding bar graph value. The following example indicates how this is accomplished:



The bar graph value is +96 (because it occurs on the plus bar graph side and at a value of 96) and the wheel value is -3. Adding these two values together results in a timing slip of +93 bits. This indicates that 93 more clock

cycles have been received at the RECEIVE input than have been received at the T1 REF input, or the RECEIVE input is receiving a higher frequency than the T1 REF input. A second example shows:

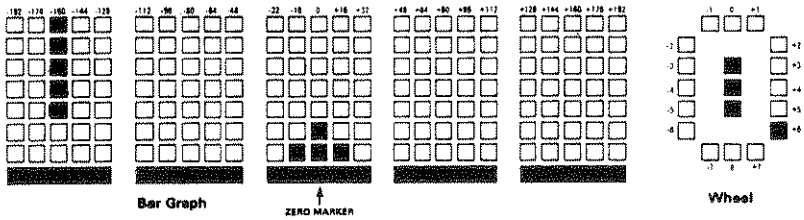

The bar graph value is -160 and the wheel value is +6. This results in a timing slip of -154 bits.

Depending on whether the signal is being received on LINE 1 or LINE 2 determines the displayed result. Table 2-6 describes the different configurations and the corresponding displayed results.

Table 2-6
Configuration vs. Displayed Results

T1 Input	Clock Reference	Displayed Results
L1	L2	L1 vs. L2 (#151)
L1 & L2	BNC	L1 vs. BNC (#151) and L2 vs. BNC (#251)
L1	BNC	L1 vs. BNC (#151)
L2	BNC	L2 vs. BNC (#251)

As shown in Table 2-6, the T-BERD 224 configuration determines the displayed result. When LINE 1 and LINE 2 are used for measuring timing slips, LINE 2 is considered to be the reference signal and LINE 1 is the signal that is compared to the LINE 2 signal. When a signal is connected to the side panel BNC connector (EXTERNAL BNC CLOCK), the BNC connector is

SECTION 2

considered to be the reference signal and the signal present at LINE 1 and/or LINE 2 are measured against the reference signal.

Timing slip results vary according to the timing relationship between the EXTERNAL BNC CLOCK and the RECEIVE connector signals, as follows:

- If the clock reference and T1 input signals are perfectly synchronized, then the timing slip count remains at 0, the bar graph remains at center, and the wheel remains at top-center.
- If the clock reference and T1 input signals are synchronized, but one signal exhibits low-speed wander (e.g., Doppler shifts from satellites), then the timing slip count remains at 0; both the bar graph and the wheel move to the right as the satellite approaches, and to the left after the satellite passes by.
- If the clock reference and T1 input signals are unsynchronized, and the T1 input frequency is higher than the clock reference frequency, then the wheel moves clockwise, the bar graph moves to the right, and the timing slip count increments every 193 bit slips. When the frequency difference is more than a few Hertz, the TIMING SLIP count, bar graph, and wheel move very rapidly.
- If the clock reference and T1 input signals are unsynchronized, and the T1 input frequency is lower than the clock reference frequency, then the wheel moves counterclockwise, the bar graph moves to the left, and the timing slip count increments every 193 bit slips. When the frequency difference is more than a few Hertz, the TIMING SLIP count, bar graph, and wheel move very rapidly.

2.6.5 TIME Category

This results category comprises time-related measurements. Table 2-7 describes the specific results available.

Table 2-7
TIME Results Category

Result Name	Description
n70 SG LS S	Signal Loss Seconds. A count of test seconds during which the signal was not present or during which one or more signal losses occurred.
n71 ALM SEC	Alarmed Seconds. A count of test seconds during which a yellow alarm, unframed all ones (AIS), or excess zeros alarm is detected. Continues to count through signal loss after detecting the alarm conditions.
n72 TST LEN	Test Length. The currently set test length for a timed test, in HHH:MM:SS format. The test length is set using AUX 03 TES LEN function.
n73 ELAP TM	Elapsed Time. The number of hours, minutes and seconds after a signal of proper frequency and level has been detected since a test restart. (Refer to Section 2.3, RESTART [7] for a list of functions which cause a test restart.) Elapsed time continues to increment during signal losses.
n74 TST END	Test Ends. Displays the time remaining for a timed test in progress using the HH:MM:SS format. "*****" is displayed when the test set is in CONTINUOUS test mode.
n75 TIME	Clock Time. Displays time of day using a 24 hour (military) clock, using the HH:MM:SS format.
n76 DATE	Calendar Date. Displays the date in the MMM DD format.

2.6.6 CHANNEL Category

This category displays information about the selected channel. Table 2-8 describes the specific results available.

Table 2-8
CHANNEL Results Category

Result Name	Description
n80 RCV BYT	Received Byte. The status of the 8 data bits for the selected dropped channel. The received byte is sampled and then displayed 7 times a second when CHANNEL FORMAT is set to DS0.
n81 VF FREQ	Voice Frequency. The frequency (Hz) of a VF tone within a selected dropped channel when the DROP switch is set to LINE 1 or LINE 2 . Available when CHANNEL FORMAT is set to VF or VF THRU . This result is not available when DROP is set to BOTH .
n82 VF LVL	VF Level. The level (dBm) of a VF signal within a selected dropped channel relative to a 0 dBm0 transmission level point (TLP). Available when CHANNEL FORMAT is set to VF or VF THRU .

PREPARATION FOR USE

3.1 INTRODUCTION

This section provides unpacking instructions, initial inspection information, operator warnings, and power requirements.

3.2 UNPACKING AND INITIAL INSPECTION

The T-BERD 224 shipping container should be inspected for damage when it is received. If the shipping container or shipping material is damaged, it should be kept until the contents of the shipment have been checked for completeness and the instrument has been checked mechanically and electrically. Procedures for checking the electrical performance of the instrument are contained in Section 3.6. If the contents are incomplete, or if the T-BERD 224 does not pass the performance tests, notify TTC. If the shipping container is damaged, notify the carrier as well as TTC, and keep the shipping container and material for the carrier's inspection.

3.3 EQUIPMENT INCLUDED

The following is a list of the equipment that should be present when the T-BERD 224 PCM Analyzer shipment is received and unpacked.

- T-BERD 224 PCM Analyzer
- Power cord
- Operating manual
- Front cover
- Snap-on pouch

3.4 WARNINGS

The following warnings list precautions that must be observed before and during all phases of instrument operation. Failure to comply with these

SECTION 3

and other specific warnings contained elsewhere in this manual may cause physical harm to the operator and/or damage to the instrument. TTC assumes no liability due to the customer's failure to comply with these requirements.

GROUND THE INSTRUMENT

To minimize shock hazard, the instrument chassis must be connected to an approved three-contact electrical outlet or used with a three-contact to two-contact adaptor with the grounding wire firmly connected to an electrical ground at the power outlet.

KEEP AWAY FROM LIVE VOLTAGES

Do not remove the instrument top cover or insert fingers or other objects through the side panel holes while power is applied to the unit.

DO NOT OPERATE IN AN AMBIENT TEMPERATURE ABOVE 50°C

Do not operate this unit in ambient temperatures that exceed 50°C. Operating this unit in temperatures above 50°C can cause damage.

3.5 POWER REQUIREMENTS

The T-BERD 224 requires one of two power sources. The T-BERD 224 is most commonly configured to operate with a single phase 48 to 66 Hz power source at 90-135 VAC. As a factory installed option, the T-BERD 224 can be configured to operate with a single phase 50 Hz power source at 195-240 VAC.

3.6 INSTRUMENT CHECKOUT

This section contains procedures to check the electrical performance of the T-BERD 224 PCM Analyzer. For more information about the individual switches and their selections, refer to Section 2.

- (1) Insert the line power cord in the three-prong power receptacle on the side panel.

WARNING: Ground the instrument. In order to minimize shock hazard, the instrument chassis must be connected to an electrical ground. This unit is equipped with a three-conductor AC power cable. The power cable must either be plugged into an approved three-contact electrical outlet or used with a three-contact to two-contact adaptor with the grounding wire (green) firmly connected to an electrical ground (safety ground) at the power outlet.

CAUTION: The T-BERD 224 should be operated with a 1 Amp, 250 V, Slo-Blo fuse installed (Littlefuse type #218001, or its equivalent). Always use the correct fuse rating.

- (2) Press the side panel **AC Power** switch to the ON (1) position to apply power to the unit and to initiate an automatic self-test. See Section 3.7 for more information describing the self-test.
- (3) During the self-test, verify that all of the front panel's discrete and switch LEDs illuminate momentarily before they are configured to the settings that were selected before the last power down. If any LEDs do not illuminate or any messages are displayed in the VF display as described in Section 3.7 (Self Test), call TTC Customer Service at 1-800-638-2049 for assistance.
- (4) Set the T1 line input termination to TERM for both LINE 1 and LINE 2 by pressing each **RECEIVE INPUT** switch until the TERM LED illuminates.
- (5) Connect a cable from LINE 1 TRANSMIT output jack to LINE 2 RECEIVE input jack.
- (6) Use the front panel **MODE** switch to select ESF as the operating mode.
- (7) Use the **CHANNEL FORMAT** switch to select VF as the channel format.
- (8) Press the **SCI** switch to select 1004 Hz.
- (9) Press the **LINE 1 CHANNEL** switch to display 01 for the selected Line 1 channel.
- (10) Press the **LINE 2 CHANNEL** switch to display 01 for the selected Line 2 channel.

SECTION 3

- (11) Press the blank **RESULTS I Category** switch to illuminate the LED to the left of the SUMMARY label.
- (12) Verify that the green SIGNAL and FRAME SYNC LEDs are illuminated for LINE 2 and that RESULTS OK appears in the RESULTS I display window.
- (13) Press the **DROP** rocker switch to illuminate the LED next to the LINE 2 label.
- (14) Press the **INSERT** rocker switch to illuminate the LED next to the LINE 1 label.
- (15) After 3 seconds, adjust the **VOLUME** control slide switch to verify the presence of a 1004 Hz tone on the side panel speaker for Line 2 dropped channel (Channel 1).
- (16) Press the **SIGNALING INSERT** switches (A, B, C, and D) to verify that the corresponding line signaling LED illuminates for Line 2.
- (17) Press the **BPV ERROR INSERT** switch and verify detection of a bipolar violation in the RESULTS I display window.
- (18) Press the **FRAME ERROR INSERT** switch and verify detection of a frame error in the RESULTS I display window by pressing the **RESULTS I Results** switch to scroll to other available SUMMARY results.
- (19) Press the **YELLOW ALARM ERROR INSERT** switch and verify that the LINE 2 yellow alarm status LED is illuminated.
- (20) Set the **INSERT** switch to NONE.
- (21) Remove the signal cables and connect one end of the cable to the L2 TRANSMIT output connector and connect the other end of the cable to the L1 RECEIVE input connector.
- (22) Press the **RESTART** switch to clear all accumulated results and reset their values to zero.
- (23) Repeat steps 12 to 20 transposing LINE 1 for LINE 2 and vice versa.

After determining that the T-BERD 224 LINE 1 and LINE 2 interfaces are functioning properly, disconnect the cables. The T-BERD 224 is ready for testing.

3.7 SELF-TEST PROCEDURE

During the self-test procedure that automatically occurs during each power up, the T-BERD 224:

- Illuminates all front panel and switch LEDs momentarily so that users may visually detect burned-out LEDs.
- Checks to see if any front-panel switches are stuck in an active position. If the **RESTART** switch is pressed momentarily during power-up, the T-BERD 224 clears non-volatile RAM (NOVRAM) and sets all switch configurations to their factory default settings as listed in Appendix A.
- Verifies that the data stored in NOVRAM is unchanged since the last power down.
- Checks the instrument's RAM, EPROM and microprocessor components.

If changes are found in the NOVRAM data, a failure message is displayed, and the factory settings, described in Appendix A, are reloaded. The T-BERD 224 remains fully functional even though switch and auxiliary settings may not have been saved during the power cycle. While the instrument may be used, TTC should be called for service.

If errors are found with the instrument's RAM, EPROM or microprocessor components, specific messages are displayed. In the event that a self-test error is visible in the display window, record the message and call TTC for service. There are no user-serviceable parts within the T-BERD 224, except the AC fuse located on the side panel.

SECTION 3

OPERATION

4.1 INTRODUCTION

This section contains information required for operating the T-BERD 224 PCM Analyzer in a variety of test scenarios. The procedures in this section assume that the user is already familiar with the T-BERD 224 controls and their functions. If you do not have a working knowledge of the T-BERD 224, refer to Section 2 for a description of the unit, controls, and connectors. Refer to Section 4.2 for descriptions of the three basic T1 connection methods; T1 circuit monitoring, drop and insert testing, and terminating a T1 circuit. As an aid, related section numbers and switch numbers are provided in appropriate steps (e.g., see Section 2.3.2 [2]).

The instrument set-up and connections applications procedures presented in Section 4.2 are referred to by all subsequent test procedures in this section. In addition, each T-BERD 224 option section contains applications procedures that will refer to the set-up and connections applications procedures for T1 circuit connection.

Section 4.2 provides set-up and connections applications for:

- Monitoring the T1 circuit (Section 4.2.1).
- Drop and insert testing of individual channels of the T1 circuit (Section 4.2.2).
- Terminating the T1 circuit with the T-BERD 224 (Section 4.2.3).

Section 4.3 provides test scenarios for:

- In-service testing of voice and data channels within a T1 circuit (Section 4.3):
 - Listening to a voice circuit (Section 4.3.1).
 - Observing signaling states of all 24 channels (Section 4.3.2).
 - Timing slips analysis (Section 4.3.3).

SECTION 4

- Out-of-service testing of voice and data channels within a T1 circuit (Section 4.4):
 - Inserting VF tones and signals (Section 4.4.1).
 - Performing DDS loopbacks (Section 4.4.2).

4.2 INSTRUMENT SET-UPS AND CONNECTIONS APPLICATIONS

The following paragraphs present procedures for connecting the T-BERD 224 to a T1 circuit for monitoring, drop and insert testing, and terminating the T1 circuit. Each subsection includes a description of the connections between the T1 circuit and the T-BERD 224, a figure illustrating the connections, a set-up procedure, and a list of applications.

4.2.1 T1 Circuit Monitoring

The T-BERD 224 provides non-intrusive monitoring of a full duplex T1 circuit, as well as any one of the 24 voice or data channels within the T1 circuit.

Figure 4-1 illustrates how the T-BERD 224 is connected to a DSX-1 patch panel to monitor a full duplex T1 circuit. Perform the procedure in Table 4-1 to set up the T-BERD 224 to monitor the desired T1 circuit. Table 4-1 is solely concerned with the switches and connections necessary to set-up the T-BERD 224 to monitor a T1 circuit. Each in-service application that requires the monitoring connections will refer the user to Table 4-1.

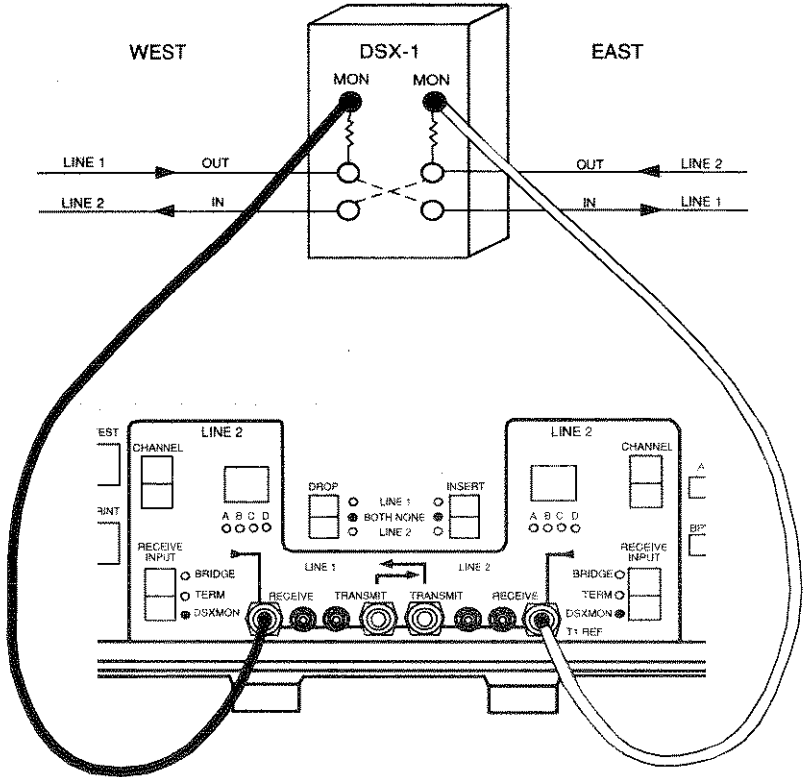

Figure 4-1
Monitoring a T1 Circuit

Table 4-1
Test Set-Up For Monitoring a T1 Circuit

Step	Controls/Indicators/ Connectors	Activity
1.	AC Power switch	Apply power to the T-BERD 224.
2.	MODE switch	Select the desired T1 framing format (e.g., T1-D4) or AUTO.
3.	CHANNEL FORMAT switch	Select the appropriate channel format for the test switch (e.g., VF for voice channels).
4.	SCI switch	Set appropriately for specific application.
5.	SCII switch	Set appropriately for specific application.
6.	VOLUME switch	Set to mid range (see Section 2.3.2 [13]).
7.	DROP switch	Set to BOTH (see Section 2.3.2 [18]).
8.	INSERT switch	Set to NONE (see Section 2.3.2 [19]).
9.	LINE 1 switches	<p>(a) Set CHANNEL switch to desired T1 channel (1 to 24).</p> <p>(b) Set RECEIVE INPUT switch to DSX MON.</p> <p>NOTE: The DSX-MON input termination is used with resistor-isolated jacks only. If the circuit is bridged using alligator clips or non-isolated monitor jacks, select BRIDGE.</p>
10.	LINE 1 RECEIVE jack	Connect a cable from the LINE 1 RECEIVE jack to DSX-1 WEST MON jack (see Figure 4-1).

Table 4-1
Test Set-Up For Monitoring a T1 Circuit (Continued)

Step	Controls/Indicators/ Connectors	Activity
11.	LINE 1 RESULTS	Verify that the green SIGNAL and FRAME SYNC LEDs are illuminated for LINE 1 and the B8ZS LED is illuminated if the circuit is using clear channel (B8ZS) line coding.
12.	LINE 2 switches	<p>(a) Set CHANNEL switch to desired T1 channel (1 to 24).</p> <p>(b) Set RECEIVE INPUT switch to DSX MON.</p> <p>NOTE: The DSX-MON input termination is used with resistor-isolated jacks only. If the circuit is bridged using alligator clips or non-isolated monitor jacks, select BRIDGE.</p>
13.	LINE 2 RECEIVE jack	Connect a cable from the LINE 2 RECEIVE jack to DSX-1 EAST MON jack (see Figure 4-1).
14.	LINE 2 RESULTS Verification	Verify that the green SIGNAL and FRAME SYNC LEDs are illuminated for LINE 2 and the B8ZS LED is illuminated if the circuit is using clear channel (B8ZS) line coding.
15.	Application continuation	If this section is part of a specific application procedure, return to the application procedure to continue.

4.2.2 Drop And Insert Testing

The T-BERD 224 provides “hitless” drop and insert to any individual channel or any combination of the 24 voice or data channels within a T1 circuit once the unit is in-line and the T1 circuit is passing through the unit. When testing channels with the T-BERD 224, users can:

- Test VF data circuits when only T1 access is available.
- Perform DDS loopbacks from T1 access points.
- Test Fractional T1 Circuits point-to-point.
- Isolate channel problems without disrupting the remaining channels within the T1 circuit.

Figure 4-2 illustrates how the T-BERD 224 is connected to the T1 circuit to perform drop and insert testing. Use the procedure in Table 4-2 to set up the T-BERD 224 to perform drop and insert testing on the desired T1 circuit. This procedure provides the switches and connections necessary to set-up the T-BERD 224 for drop and insert testing. Each application that uses the drop and insert testing connections will refer the user to this procedure.

Table 4-2 has the user position the DROP switch to BOTH and the INSERT switch to NONE initially. These switch positions are necessary to minimize the interruption of the T1 circuit during the connection procedure. Once the T-BERD 224 is connected to the T1 circuit, individual channels can be tested.

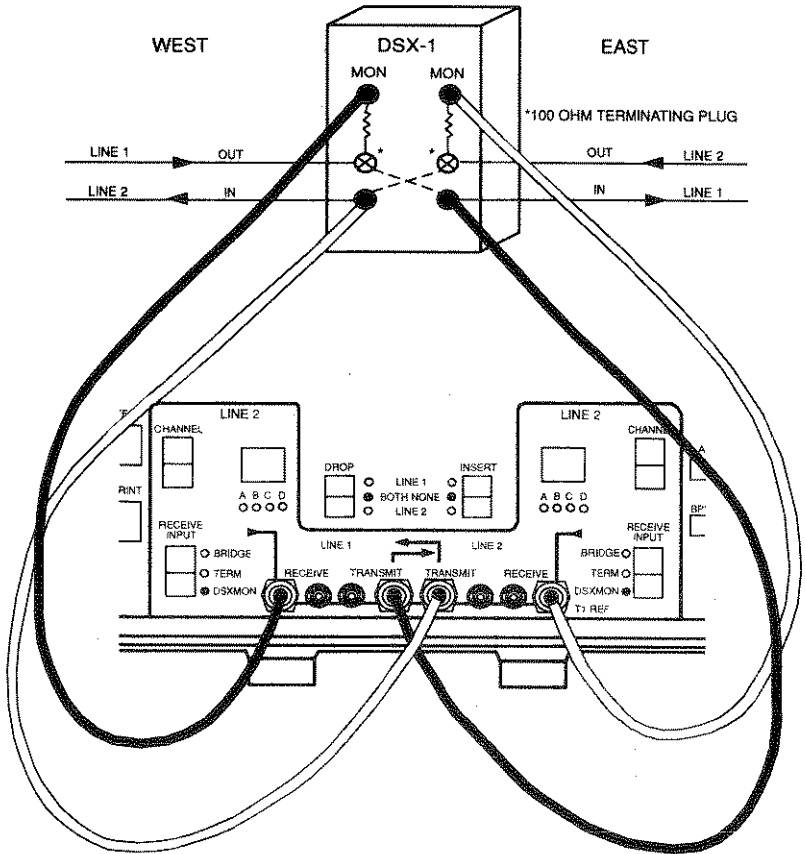

Figure 4-2
Equipment Connections for Drop and Insert Testing

Table 4-2
Test Set-Up For Drop and Insert Testing

Step	Controls/Indicators/ Connectors	Activity
1.	AC Power switch	Apply power to the T-BERD 224.
2.	MODE switch	Select the desired T1 framing format (e.g., T1-D4) or AUTO.
3.	CHANNEL FORMAT switch	Select the appropriate channel format for the test switch (e.g., VF for voice channels).
4.	SCI switch	Set appropriately for specific application.
5.	SCII switch	Set appropriately for specific application.
6.	VOLUME switch	Set to mid range (see Section 2.3.2 [13]).
7.	DROP switch	Set to BOTH (see Section 2.3.2 [18]).
8.	INSERT switch	Set to NONE (see Section 2.3.2 [19]).
9.	AUX switch	Select Auxiliary functions (AUX switch LED is illuminated).
10.	MODE switch	Select AUX 05 LBO. Set both LINE 1 and LINE 2 LBO to 0 dB.
11.	AUX switch	Press to release auxiliary functions (AUX switch LED is extinguished).
12.	LINE 1 switches	<p>(a) Set CHANNEL switch to desired T1 channel (1 to 24).</p> <p>(b) Set RECEIVE INPUT switch to DSX MON.</p> <p>NOTE: The DSX-MON input termination is for resistor-isolated jacks only. If the circuit is bridged using alligator clips or non-isolated monitor jacks, select BRIDGE.</p>
13.	LINE 1 RECEIVE jack	Connect a cable from the LINE 1 RECEIVE jack to DSX-1 WEST MON jack (see Figure 4-2).

Table 4-2
Test Set-Up For Drop and Insert Testing (Continued)

Step	Controls/Indicators/ Connectors	Activity
14.	LINE 1 RESULTS Verification	<p>CAUTION: To avoid taking the line down, do not connect the TRANSMIT output jack to the line until Step 17.</p> <p>Verify that the green SIGNAL and FRAME SYNC LEDs are illuminated for LINE 1 and the B8ZS LED is illuminated if the circuit is using clear channel (B8ZS) line coding.</p>
15.	CODE switch	<p>Select B8ZS coding if the B8ZS LED is illuminated. If it is extinguished, select AMI coding.</p>
16.	RESULTS I Category switch	<p>Set to CHANNEL.</p>
17.	LINE 1 TRANSMIT jack	<p>Connect a cable from the T-BERD 224 TRANSMIT jack to the DSX-1 EAST IN jack (see Figure 4-2).</p> <p>CAUTION: Connect one end of the cable into the T-BERD 224 first, then connect the other end into the DSX-1 EAST IN jack. If the cable is connected to the DSX-1 jack first, it will take down the T1 circuit.</p>
18.	100 ohm terminating plugs	<p>Insert a 100 ohm terminating plug into the DSX-1 WEST OUT jack to avoid line imbalances (see Figure 4-2).</p> <p>NOTE: At this point, the WEST-TO-EAST leg of the T1 circuit is passing through the T-BERD 224.</p>
19.	LINE 2 switches	<p>(a) Set CHANNEL switch to desired T1 channel (1 to 24).</p> <p>(b) Set RECEIVE INPUT switch to DSX MON.</p> <p>NOTE: The DSX-MON input termination is for resistor-isolated jacks only. If the circuit is bridged using alligator clips or non-isolated monitor jacks, select BRIDGE.</p>

Table 4-2
Test Set-Up For Drop and Insert Testing (Continued)

Step	Controls/Indicators/ Connectors	Activity
20.	LINE 2 RECEIVE jack	<p>Connect a cable from the LINE 2 RECEIVE jack to DSX-1 EAST MON jack (see Figure 4-2).</p> <p>CAUTION: To avoid taking the line down, do not connect the TRANSMIT output jacks to the line until Step 23.</p>
21.	LINE 2 RESULTS Verification	<p>Verify that the green SIGNAL and FRAME SYNC LEDs are illuminated for LINE 2 and the B8ZS LED is illuminated if the circuit is using clear channel (B8ZS) line coding.</p>
22.	RESULTS II Category switch	<p>Set to CHANNEL.</p>
23.	LINE 2 TRANSMIT jack	<p>Connect a cable from the T-BERD 224 TRANSMIT jack to the DSX-1 WEST IN jack (see Figure 4-2).</p> <p>CAUTION: Connect one end of the cable into the T-BERD 224 first, then connect the other end into the DSX-1 EAST IN jack. If the cable is connected to the DSX-1 jack first, it will take down the T1 circuit.</p>
25.	100 ohm terminating plugs	<p>Insert a 100 ohm terminating plug into the DSX-1 EAST OUT jack to avoid line imbalances (see Figure 4-2).</p> <p>NOTE: At this point, the full-duplex T1 circuit is passing through the T-BERD 224.</p>
27.	Application continuation	<p>Return to the application procedure.</p>

4.2.3 T1 Circuit Termination

Terminating the T1 circuit is performed on an out-of-service T1 span. This set-up allows the user to test the entire T1 span in one direction from the T-BERD 224 test location to a central office or CSU. End-to-end testing can be performed with a test set at each end of the span, or the T1 circuit can be looped at the far end to allow the T-BERD 224 to analyze the returning signal. Testing is done in only one direction.

Figure 4-3 illustrates how the T-BERD 224 is connected to the T1 circuit to terminate traffic in the EAST direction. Perform the procedure in Table 4-3 to set up the T-BERD 224 to terminate the desired T1 span. To terminate the circuit in the WEST direction, follow the same procedure substituting WEST for EAST in the applicable steps. Table 4-3 is solely concerned with the switches and connections necessary to set-up the T-BERD 224 to terminate a T1 circuit. Each application that requires T1 circuit termination connections will refer the user to the Table 4-3 set-up procedure.

SECTION 4

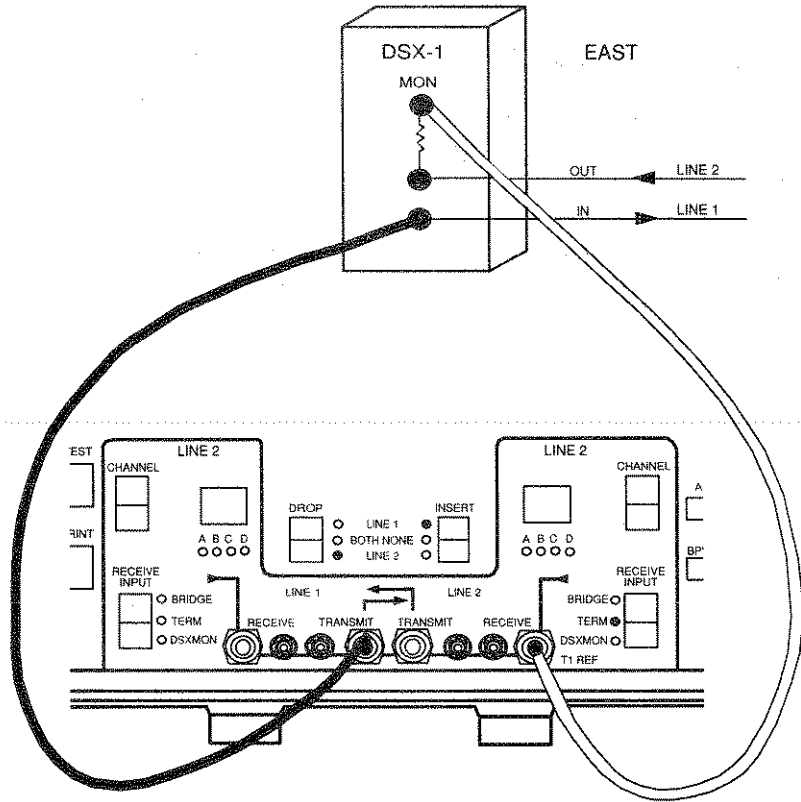

Figure 4-3
T1 Circuit Termination Set-up

Table 4-3
Test Set-Up For T1 Circuit Termination

Step	Controls/Indicators/ Connectors	Activity
1.	AC Power switch	Apply power to the T-BERD 224.
2.	MODE switch	Select the desired T1 framing format (e.g., T1-D4) or AUTO.
3.	CHANNEL FORMAT switch	Select the appropriate channel format for the test (e.g., VF for voice channels).
4.	SCI switch	Set appropriately for specific application.
5.	SCII switch	Set appropriately for specific application.
6.	VOLUME switch	Set to mid range (see Section 2.3.2 [13]).
7.	INSERT switch	Select LINE 1.
8.	DROP switch	Select LINE 2.
9.	AUX switch	Press to enable the auxiliary function and illuminate the AUX switch LED.
10.	MODE switch	Select AUX 05 LBO. Set both LINE 1 and LINE 2 LBO to 0 dB, -7.5 dB, or -15 dB, as applicable.
11.	MODE switch	Select AUX 06 BACKTM. Set backup timing to INTERNAL to enable the T-BERD 224 to generate the T1 signal using its internal clock.
12.	AUX switch	Press to release auxiliary functions (AUX switch LED is extinguished).
13.	LINE 2 switches	(a) Set CHANNEL switch to desired T1 channel (1 to 24, ALL). (b) Set RECEIVE INPUT switch to TERM.
14.	LINE 2 RECEIVE jack	Connect a cable from the LINE 2 RECEIVE jack to the DSX-1 EAST OUT jack (Refer to Figure 4-3).
15.	LINE 1 TRANSMIT jack	Connect a cable from the T-BERD 224 LINE 2 TRANSMIT jack to the DSX-1 EAST IN jack (Refer to Figure 4-3).
16.	Application continuation	Return to the application procedure.

4.3 IN-SERVICE TESTING APPLICATIONS

Bridging or monitoring the T1 circuit in both directions enables users to simultaneously monitor any one of the 24 channels in both directions and observe the signaling bits of all 24 channels for both T1 inputs. The T-BERD 224 can also monitor one direction at a time while bridging the T1 circuit in both directions. Monitoring one direction at a time helps to determine which circuit direction (e.g., facility-to-equipment or equipment-to-facility) is providing the error source.

4.3.1 Listening To A Voice Circuit

By bridging or monitoring the T1 circuit in both directions, the T-BERD 224 enables users to simultaneously listen to any one of the 24 channels in both directions with the internal speaker. While the voice circuit is output to the speaker, the T-BERD 224 performs analysis on both T1 inputs for bipolar violations, frame errors, and signal impairments.

Monitoring a T1 circuit from a T1 access point enables users to:

- Verify continuity during circuit installations.
- Check Voice Frequency (VF) signal levels audibly and visually.
- Confirm reported fault conditions.
- Determine the location of error sources.

Types of T1 circuits which carry voice channels include interoffice trunks, PBX trunks, and digital loop carrier circuits (e.g., SLC-96 and SLC Series 5). Use the procedure in Table 4-4 to collect and printout results when monitoring a VF circuit from a T1 access point.

Table 4-4
Procedure For Listening To A Voice Circuit

Step	Controls/Indicators/ Connectors	Activity
1.	T1 Circuit Connections	Perform the procedure in Table 4-1 to connect the T-BERD 224 to the T1 circuit for monitoring with the following switch positions: <ul style="list-style-type: none"> (a) MODE switch is set to desired T1 format or AUTO. (b) CHANNEL FORMAT switch is set to VF.
2.	VOLUME switch	Set as required for clear audible signal (see Section 2.3.2 [13]).
3.	RESTART switch	Press to begin the test.
4.	LOCAL STATUS LEDs	Verify that no red current status LEDs are illuminated, except B8ZS history, which may illuminate normally.
5.	RESULTS I Category switch	Select the SUMMARY Category.
6.	RESULTS I Results switch	The RESULTS I display should read RESULTS OK. If not, scroll through the SUMMARY Category results to identify any out-of-specification results.
7.	Internal speaker	Listen to both transmission directions of the selected VF channel.
8.	DROP switch	Set to monitor LINE 1, then LINE 2, then BOTH.
9.	Internal speaker	Listen to each transmission direction and compare sound quality and level.
10.	PRINTER/REMOTE RS-232Connector or AUXILIARY PORT Connector	Connect a printer to the T-BERD 224.
11.	PRINT switch	Select RESULTS to produce a time- and date-stamped printout of the results (see Section 2.3.2 [20]).

SECTION 4

Refer to the following items to interpret the test results:

- If frame errors, CRC errors, and BPVs are detected, it is likely that the errors are being introduced by the near-end repeatered span.
- If frame errors or CRC errors are detected, but the BPV count remains at 0, it is likely that errors are not being introduced at the near-end repeatered span and further sectionalization is required.
- If the volume output of one transmission direction is significantly lower than the other direction, or audible “pops” or “crackles” are coming from one transmission direction, then move the test set toward the origin of the faulty transmission direction to isolate the fault source.

4.3.2 Observing Signaling Bits of All 24 Channels

The TRAFFIC result simultaneously displays both A and B signaling bits for both T1 inputs or A, B, C, and D bits for either input if ESF or ESFz framing is used. While the signaling bits are displayed, the T-BERD 224 is analyzing both T1 inputs for bipolar violations, frame errors, and signal impairments.

Monitoring the signaling bits of a T1 circuit from a T1 access point enables users to:

- Locate a channel that is carrying traffic.
- Observe “handshaking” between communications equipment, such as switches and PBXs.
- Detect “stuck” or “hung” channels.

This test is most often used on T1 circuits in central offices, customer premises, and remote terminals of digital loop carrier systems. Use the procedure in Table 4-5 to collect and printout results when monitoring a VF circuit from a T1 access point.

Table 4-5
Procedure For Observing Signaling States of All 24 Channels

Step	Controls/Indicators/ Connectors	Activity
1.	T1 Circuit Connections	<p>Perform the procedure in Table 4-1 to connect the T-BERD 224 to the T1 circuit for monitoring with the following switch positions:</p> <p>(a) MODE switch is set to desired T1 format or AUTO.</p> <p>(b) CHANNEL FORMAT switch is set to VF.</p>
2.	RESTART switch	Press to begin the test.
3.	LOCAL STATUS LEDs	Verify that no red current status LEDs are illuminated, except B8ZS history, which may illuminate normally.
4.	RESULTS I Category switch	Select the SUMMARY Category.
5.	RESULTS I Results switch	The RESULTS I display should read RESULTS OK. If not, scroll through the SUMMARY Category results to identify any out-of-specification results.
6.	RESULTS II Category switch	Select the SIGNAL Category.
7.	RESULTS II Results switch	Select n55 TRAFFIC (n56 TRAFFIC for ESF and ESFz modes), where n equals line number 1 or 2, and observe the signaling states of each T1 circuit's 24 channels.
8.	PRINTER/REMOTE RS-232 or AUXILIARY PORT Connector	Connect a printer to the T-BERD 224.
9.	PRINT switch	Select RESULTS to produce a time- and date-stamped printout of the results (see Section 2.3.2 [20]).

SECTION 4

Refer to the following items to interpret the test results:

- If frame errors, CRC errors, and BPVs are detected, it is likely that the errors are being introduced by the near-end repeatered span.
- If frame errors or CRC errors are detected, but the BPV count remains at 0, it is likely that errors are not being introduced at the near-end repeatered span and further sectionalization is required.

4.3.3 Timing Slips Analysis

The T-BERD 224 timing slip measurement identifies frequency variations which cause uncontrolled clock slips. When measuring timing slips two analysis configurations are available:

- The received T1 signal (LINE 1) is compared with a reference T1 clock source (LINE 2).
- Both received T1 signals (LINE 1 and LINE 2) are compared with a clock reference source present at the side panel BNC connector.

If a T1 clock signal is attached to the side panel BNC connector, Timing Slip Analysis is performed for both LINE 1 and LINE 2. These two signals are compared, allowing the T-BERD 224 to count the number of times that the recovered clock edges of the received signal move past (slips) the edges of the reference signal.

Perform the procedure in Table 4-6 to set up, test, and collect the results when testing for the presence of timing slips when analyzing LINE 1 vs. LINE 2.

Table 4-6
Procedure for Testing for Timing Slips

Step	Controls/Indicators/ Connectors	Activity
1.	T1 Circuit Connections	<p>Perform the procedure in Table 4-1 to connect the T-BERD 224 to the T1 circuit for monitoring with the following switch positions:</p> <p>(a) MODE switch is set to desired T1 format or AUTO.</p> <p>(b) CHANNEL FORMAT switch is set to VF.</p>
2.	RESULTS I Category switch	Select the SUMMARY Category.
3.	RESTART switch	Press to begin the test.
4.	RESULTS I Results switch	The RESULTS I display should read RESULTS OK. If not, scroll through the SUMMARY Category results to identify any out-of-specification results.
5.	RESULTS I Category switch	Select the SIGNAL Category.
6.	RESULTS I Results switch	<p>Select n51 TM SLP to see the comparison of the received signal to the T1 reference signal.</p> <p>NOTE: The n51 TM SLP result is only available for LINE 1 if LINE 2 is acting as the T1 reference signal. However, if an external clock source is connected to the side panel BNC connector, both LINE 1 and LINE 2 results are available.</p>
7.	RESULTS II Category switch	Select the SIGNAL Category.
8.	RESULTS II Results switch	<p>Select 152 SLP SEC to see the number of seconds of timing slip analysis.</p> <p>NOTE: The n52 SLP SEC result should increment (accumulate) when both the T1 reference signal (LINE 2) and the received signal (LINE 1) are present. This result does not accumulate when either of these input signals is lost.</p>

SECTION 4

Refer to the following to interpret the test results:

- If the T1 reference and receive signals are perfectly synchronized, the timing slip count remains at 0, the bar graph remains at center, and the wheel remains at top-center.
- If the T1 reference and received signals are synchronized, but one signal exhibits low-speed wander (e.g., Doppler shifts from satellites), the timing slip count remains at 0 and the bar graph and the wheel move to the right as the satellite nears and to the left as the satellite moves farther away.
- If the T1 reference and received signals are unsynchronized, and the received signal frequency is higher than the T1 reference signal, the wheel moves clockwise, the bar graph moves to the right, and the timing slip increments every 193 bit slips. When the frequency difference is more than a few cycles (Hertz), the TM SLIP count, bar graph, and wheel move very rapidly.
- If the T1 reference and receive signals are unsynchronized, and the receive signal frequency is lower than the T1 reference signal, then the wheel moves counterclockwise, the bar graph moves to the left, and the timing slip count increments every 193 bit slips. When the frequency difference is more than a few Hertz, the TM SLIP count, bar graph, and wheel move very rapidly.

4.4 OUT-OF-SERVICE TESTING APPLICATIONS

There are two methods of performing out-of-service testing: end-to-end testing and loopback testing. The T-BERD 224 configuration is similar for both types of testing. The two major differences are: 1) equipment needed and 2) the establishment of a loopback, addressed as follows:

- **End-to-End Testing** - End-to-end testing is performed with two test sets such that analysis is performed in both directions simultaneously. One of the test sets is a T-BERD 224 at a T1 access point. The other test set is either another T-BERD 224 at a T1 access point or an analog VF test set which is capable of transmitting and receiving various tones and waveforms from an analog access point. End-to-end testing is usually performed on voice-grade circuits since, typically, VF loopbacks can not be remotely

established via loop codes or tones. Further, end-to-end analysis is better than loopback testing because the error source direction, as well as location, may be found more quickly.

- **Loopback Testing** - Loopback testing is performed with a single T-BERD 224 so that the transmitted test tones return to the T-BERD 224 for analysis. The T1 circuit/channel is either looped manually with a jumper cable at the far-end or electronically by the T-BERD 224 when either the BERT Option or VF Option is installed. Both transmission directions are tested, such that results will indicate general error source location but not direction.

NOTE: If the BERT Option is installed, the T-BERD 224 provides loop codes to loopback far-end equipment such as CSUs. If the VF Option is installed, the T-BERD 224 can transmit a 2713 Hz tone to loopback far-end equipment.

While performing an out-of-service test on a specific channel, the T-BERD 224 analyzes both T1 inputs for bipolar violations, frame errors, and signal impairments.

The following applications discuss testing a channel(s) on an out-of-service basis, while the remaining 23 (or fewer) channels are passed through the T-BERD 224 unaffected. By placing the T-BERD 224 in-line so that the T1 circuit passes through the unit, users can overwrite any channel's contents with data or tone to perform loopback and end-to-end tests without disrupting the remaining channels.

Drop and insert testing applications presented include:

- Inserting a 1004 Hz tone on a voice frequency channel from a T1 access point.
- Inserting signals on a DDS channel from a T1 access point.

4.4.1 Inserting a 1004 Hz Tone On a Voice Frequency Channel

This type of test is most often used on T1 channels carrying voice traffic within interoffice trunks, PBX trunks, and digital loop carrier circuits (e.g., SLC-96 SLC Series 5, and DMS-1 systems).

SECTION 4

Inserting tones and analog signals on a voice channel enables users to:

- Verify continuity during circuit installations.
- Audibly check signal levels.
- Verify reported fault conditions.
- Determine the location of error sources.

Figure 4-4 illustrates the test set-up for inserting a 1004 Hz tone on a voice frequency (VF) channel. Perform the procedure in Table 4-6 to test and collect the results when inserting a 1004 Hz tone into a voice channel within a T1 circuit.

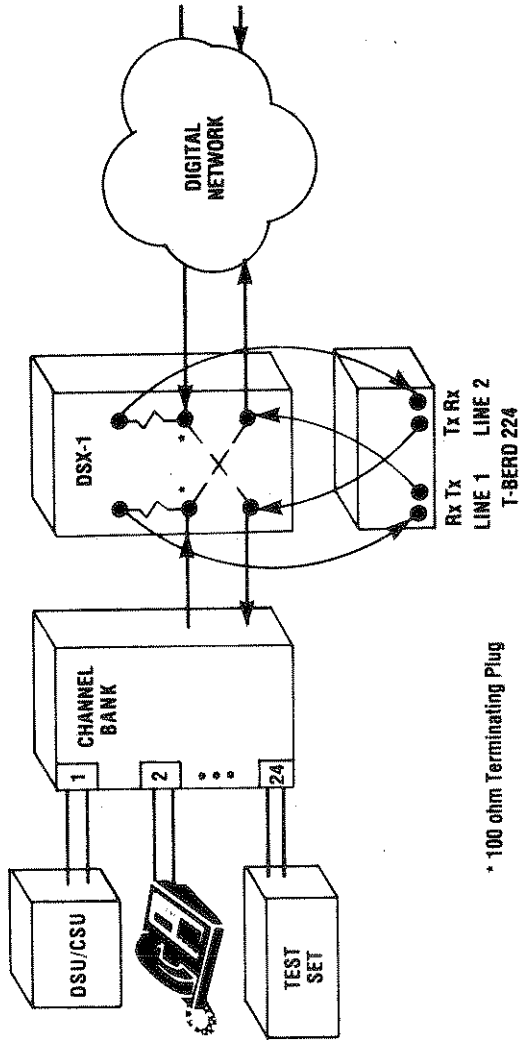

Figure 4-4
Equipment Connections for Inserting a 1004 Hz Tone on a VF Channel

Table 4-7
Test Procedure for Inserting a 1004 Hz Tone on a VF Channel

Step	Controls/Indicators/Connectors	Activity
1.	T1 Circuit Connections	<p>Perform the procedure in Table 4-1 to connect the T-BERD 224 to the T1 circuit for monitoring with the following switch positions:</p> <p>(a) MODE switch is set to desired T1 format or AUTO.</p> <p>(b) CHANNEL FORMAT switch is set to VF.</p> <p>(c) SCI switch is set to 1004 Hz.</p>
2.	INSERT switch	Select either LINE 1 or LINE 2.
3.	DROP switch	Select the line opposite the INSERT switch selection. You are analyzing the same channel on the opposite T1 line.
4.	TEST switch	Set to CONT.
5.	Internal speaker	Verify continuity by listening to the 1004 Hz tone.
6.	RESTART switch	Press to begin the test.
7.	LOCAL STATUS LEDs	Verify that no red LEDs are illuminated, except B8ZS history, which may illuminate normally.
8.	RESULTS I Category switch	Select the SUMMARY Category.
9.	RESULTS I Results switch	The RESULTS I display should read RESULTS OK. If not, scroll through the SUMMARY Category results to identify any out-of-specification results.

Table 4-7
Test Procedure for Inserting a 1004 Hz Tone on a VF Channel
(Continued)

Step	Controls/Indicators/ Connectors	Activity
10.	RESULTS II Category switch	Select the CHANNEL Category.
11.	RESULTS II Results switch	Select n81 VF FREQ, where n equals the line number being dropped. Record the result.
12.	RESULTS II Results switch	Select n82 VFLVL, where n equals the line number being dropped. Record the result.
13.	PRINTER/REMOTE RS-232Connector or AUXILIARY PORT Connector	Connect a printer to the T-BERD 224.
14.	PRINT switch	Select RESULTS to produce a time- and date-stamped printout of the results.

Refer to the following items to interpret the test results:

- If frame errors, CRC errors, and BPVs are detected, it is likely that the errors are being introduced by the near-end repeatered span.
- If frame errors or CRC errors are detected, but the BPV count remains at 0, it is likely that errors are not being introduced at the near-end repeatered span and further sectionalization is required.
- If the VF LEVEL or VF FREQ are not within appropriate ranges, the channel card within the originating channel bank may need to be adjusted or replaced.

SECTION 4

4.4.2 Inserting Signals On a DDS Channel

This type of test is most often used on T1 channels carrying DDS traffic within interoffice trunks, and possibly digital loop carrier circuits.

Inserting test patterns and loop codes on DDS channels enables user to:

- Verify continuity during circuit installations.
- Isolate reported faults by performing loopbacks.

Figure 4-5 illustrates how the T-BERD 224 is connected to the T1 circuit at a DSX-1 patch panel. Figure 4-6 illustrates how to connect a KS-Type Test Set to the T-BERD 224 DS0 Interface. Perform the procedure in Table 4-8 to test and collect the results when inserting DDS loop codes and test patterns on a DDS channel within a T1 circuit.

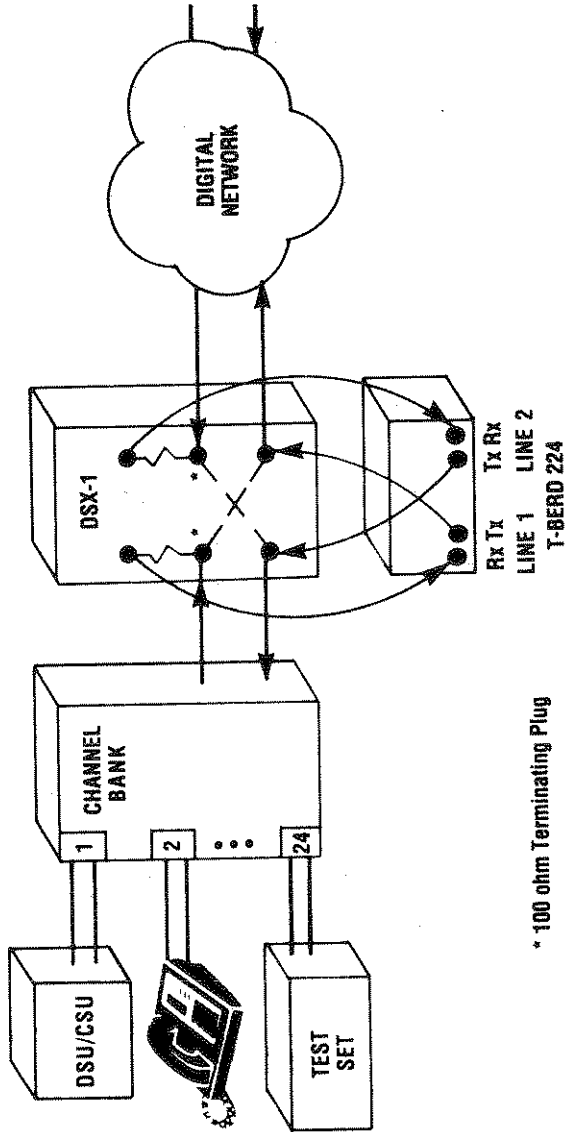

* 100 ohm Terminating Plug

Figure 4-5
Inserting Signals on DDS Channels Set-up

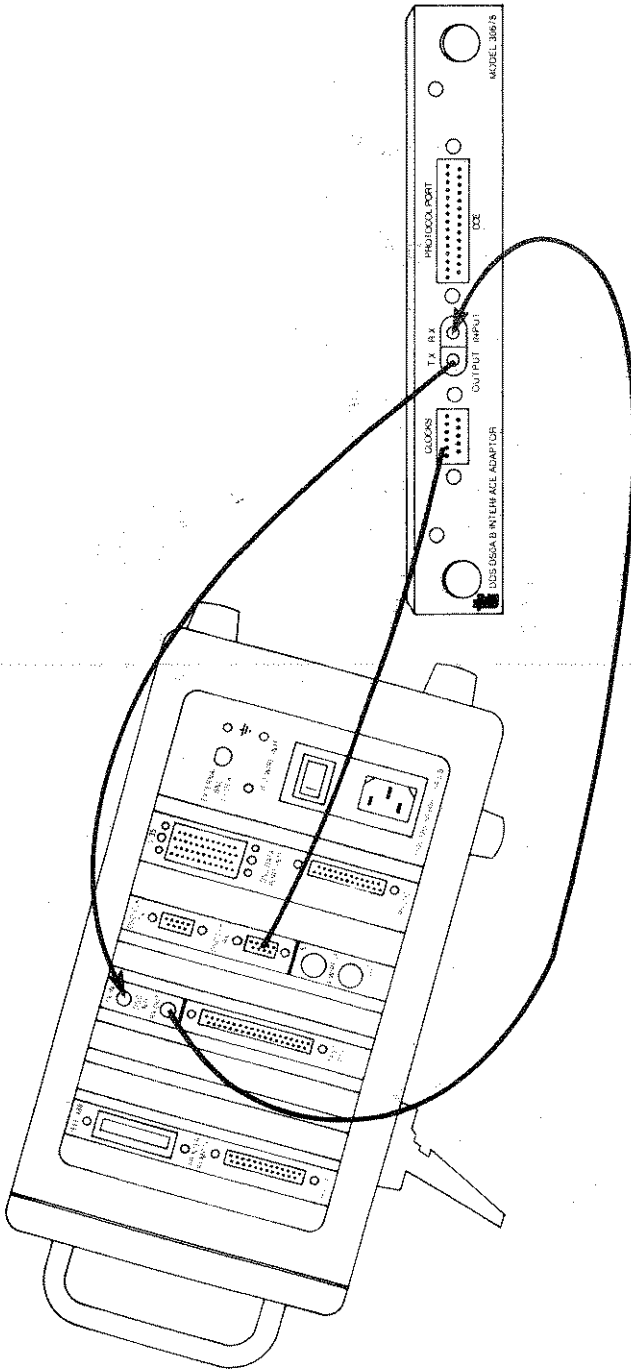

Figure 4-6
KS-Type Test Set Connections

Table 4-8
Test Procedure for Testing DDS Channels

Step	Controls/Indicators/ Connectors	Activity
1.	T1 Circuit Connections	<p>Perform the procedure in Table 4-1 to connect the T-BERD 224 to the T1 circuit for monitoring with the following switch positions:</p> <p>(a) MODE switch is set to desired T1 format or AUTO.</p> <p>(b) CHANNEL FORMAT switch is set to DS0.</p> <p>(c) SCI switch is set to DS0 INTF.</p>
2.	TEST switch	Set to CONT.
3.	RESTART switch	Press to begin the test.
4.	DS0 Interface Connection	Connect a KS-type test set to the interface on the side panel, as shown in Figure 4-6.
5.	KS-type test set Power switch	Apply power to the KS-type test set and ensure that it is set for bipolar data with the appropriate framing and data rate.
6.	LOCAL STATUS LEDs	Verify that no red LEDs are illuminated, except B8ZS history, which may illuminate normally.
7.	RESULTS I Category switch	Select the SUMMARY Category.
8.	RESULTS I Results switch	The RESULTS I display should read RESULTS OK. If not, scroll through the SUMMARY Category results to identify any out-of-specification results. Of special interest is timing slips (n51 TMSLP), which must be zero.

SECTION 4

Table 4-8
Test Procedure for Testing DDS Channels (Continued)

Step	Controls/Indicators/ Connectors	Activity
9.	AUX switch	Select Auxiliary functions (AUX switch LED is illuminated).
10.	MODE switch	Select AUX 07 DSO TM. Set LINE 1 and LINE 2 DSO TM to COMMON.
11.	AUX switch	Exit Auxiliary functions (AUX switch LED is not illuminated).
12.	INSERT switch	Select either LINE 1 or LINE 2 to insert data from the external KS-type test set.
13.	DROP switch	Select the line opposite the INSERT switch selection.
14.	ERROR INSERT switch	Verify the KS-type test set's pattern synchronization by inserting and detecting logic errors.
15.	KS-type test set RESTART switch	Restart the KS-type test set to begin the test.
16.	PRINTER/REMOTE RS-232 Connector or AUXILIARY PORT Connector	Connect a printer to the T-BERD 224.
17.	PRINT switch	Select RESULTS to produce a time- and date-stamped printout of the results.

Refer to the following items to interpret the test results:

- If frame errors, CRC errors, and BPVs are detected, it is likely that the errors are being introduced by the near-end repeatered span.
- If frame errors or CRC errors are detected, but the BPV count remains at 0, it is likely that errors are not being introduced at the near-end repeatered span and further sectionalization is required.

SECTION 4

PRINTER OPERATION

5.1 INTRODUCTION

This section describes the T-BERD 224 use of the AUXILIARY PORT connector, the side panel RS-232 Printer/Remote Control Interface, and the optional IEEE-488 Interface.

5.2 COMPATIBLE PRINTERS

The T-BERD 224 can generate printouts using either the thermal lid printer or an RS-232 compatible serial printer. Using the front panel printer connector (AUXILIARY PORT), the T-BERD 224 generates printouts to the optional thermal lid printer. Using the RS-232 Printer/Remote Control Interface, the T-BERD 224 generates printouts to an RS-232-compatible serial printer, such as the PR-40A.

5.3 PRINTOUTS

The T-BERD 224 can generate three types of printouts: Controls, Results, and Status Messages. Each printout is identified by a header and is time- and date-stamped. The following sections describe each of the available printouts and how to generate them.

The T-BERD 224 can store up to 10 results prints and 10 controls prints if a printer is not connected to the unit at the time the printouts are generated. In the event that a power loss occurs a results printout is also stored. This power loss printout is generated, along with any other stored printouts, when power is restored and a printer is connected to the printer port.

The printer buffer can be cleared by selecting Auxiliary Function 01 (CL FIFO) and pressing the **SCII** switch.

5.3.1 Results

A results printout is a hard-copy listing of the current test results. Each result printout is labeled indicating the reason the printout occurred. See Figure 5-1.

SECTION 5

MANUAL PRINT	08:22:05	JAN 09	BPVS1:	UNAVAIL	BPVS2:	0
BPV S 1:	UNAVAIL	0	BPV RT1:	UNAVAIL	BPV RT2:	0. E-09
FRM ES1:	UNAVAIL	0	FR SES1:	UNAVAIL	FR SES2:	0
FRM ER1:	UNAVAIL	0	FR ERT1:	UNAVAIL	FR ERT2:	0. E-06
FR LOS1:	UNAVAIL	0	FR L S1:	UNAVAIL	FR L S2:	0
RCV FR1:	UNAVAIL	1544000	RCV LV1:	UNAVAIL	RCV LV2:	-0.3dBdsx
RCV LV1:	UNAVAIL	UNAVAIL	RCV IV1:	UNAVAIL	RCV IV2:	5.82 V
TM SLI1:	UNAVAIL	UNAVAIL	SLI SC1:	UNAVAIL	SLI SC2:	UNAVAIL
SIG LS1:	UNAVAIL	0	ALM SC1:	UNAVAIL	ALM SC2:	0
ELA TM1:	UNAVAIL	00:14:15	TST END:	*****	RCV BY1:	UNAVAIL
RCV BY2:	iiiiiiiii	UNAVAIL	RCV CD2:	D	IDLE	

Figure 5-1
RESULTS Printout

A results print can be generated manually or automatically.

- Manually generate a results print by pressing the **PRINT** switch to the **RESULTS** position. When pressed, the **PRINT** switch generates the results print immediately.
- Automatically generate a results print depending on the position of the **PRINT EVENT** switch.

The **PRINT EVENT** switch is a four-position electronic switch. LED indicators adjacent to the switch labels illuminate to reflect the current position of the switch. The switch positions and their functions are as follows:

OFF — Sends no automatic printouts to either the **AUXILIARY PORT** or to the **RS-232** connector. Note that controls and manual results prints are still available using the **PRINT** switch. No status messages are generated when the **PRINT EVENT** switch is set to **OFF**. At power up, the power-down results print is generated.

TIMED — Initiates a results printout at the completion of a timed interval and print status messages if alarm conditions occur. The **AUX 02 TIM PRI** function is used to set the timed print interval. Refer to Section 2.5 for more information on the operation of the auxiliary functions.

ERR SEC — Initiates a results printout for each second on the occurrence of **BPVs**, frame errors or **CRC** errors, as well as status messages for alarm condition changes.

TEST END — Initiates a results printout at the completion of a timed test and print status messages if alarm conditions occur. The **AUX 03 TES LEN** function is used to set the timed test length. Refer to Section 2.5 for more information on the operation of the auxiliary functions.

An automatic squelch feature is included in the T-BERD 224 that is activated whenever 20 or more errors occur in a 60-second period. With the printout of the 20th message, a time-stamped message is sent indicating that the squelch feature is enabled. While the squelch feature is on, no automatic results or status messages are printed. The squelch feature is automatically disabled when 5 or less error events occur in a 60 second interval. When this condition is met, another time-stamped message is sent indicating that the squelch feature is disabled.

SECTION 5

NOTE: The squelch feature can be reset by clearing the AUX 01 CL FIFO function, changing the **PRINT EVENT** switch setting, or completing a timed test.

5.3.2 Overflow Results

A results count that has just overflowed is preceded by two asterisks the first time it is printed out. All succeeding printouts of the overflowed results value are preceded by a single asterisk, indicating that the overflow condition did not just happen and the results continue to increment. All asterisks are cleared when a test is restarted.

5.3.3 Controls

The controls print lists the current setting of all front-panel switches and the auxiliary functions. A controls print is initiated by pressing the **PRINT** switch to the **CONTROLS** position. Figure 5-2 is an example of a controls printout.

5.3.4 Alarm Status Messages

Unless the **PRINT EVENT** switch is set to the **OFF** position, alarm messages are initiated automatically to inform you of any important developments related to your ongoing test. The format for an alarm message is:

```
alarm message name  
HH:MM:SS MMM DD
```

Possible messages are:

Alarm Messages

L1L2 SIGNAL LOSS XX — Valid T1 pulses are no longer present on the specified line. Where **XX** = a running count of signal losses for that line since the start of the test.

L1L2 FRM SYN LOS XX — The framing pattern is no longer present on the specified line. Where **XX** = a running count of frame sync losses for that line since the start of the test.

```

CONTROLS PRINT      08:22:07      JAN 09
MODE:      T1SLC96      CHAN FOR:      DS0      SOU 1:      DS0      SOU 2:      00000000
DIS HOL:      OFF      CODE:      AMI      TIMED/CONT:      CONT      LI CHAN:      1
L2 CHAN:      1      DROP:      BOTH      INSERT:      NONE      L1 REC INP:      TERM
LS REC INP:      TERM      PRI EVE:      OFF      SIG A BIT:      OFF      SIG B BIT:      OFF
SIG C BIT:      OFF      SIG D BIT:      OFF      ERR INS BPV:      OFF      ERR INS FRA:      OFF
ERR INS YEL:      OFF
AUX FUNCS:
TIM PRI:      06:00:00      TES LEN:      200:00:00      LI LBO:      0dB      L2 LBO:      0dB
BACK TIM:      INTERNAL      DS0 TIM:      COMMON      PARITY:
PRI/REM TERM:      CRLF

```

Figure 5-2
CONTROLS Printout

SECTION 5

L11L2 YELL ALARM ON — A yellow alarm has been received on the specified line.

L11L2 YELL ALARM OFF — A yellow alarm is no longer being received on the specified line.

L11L2 EXCESS ZERO ON — More than 16 consecutive zeros have been received on the specified line.

L11L2 EXCESS ZERO OFF — Less than 16 consecutive zeros have been received on the specified line which previously detected excess zeros condition.

L11L2 AIS ON — The specified line has no zeros on it. Consecutive unframed logical ones (AIS) have been detected in the data stream input on the specified line.

L11L2 AIS OFF — A zero has been detected on the specified line. One or more zeros have been detected in the line previously marked as receiving all logical ones (AIS).

Status Messages

L11L2 SIGNAL DETECT — T1 pulses of valid frequency and level are present on the specified line.

L11L2 FRM SYN ACQUIRE — The framing pattern has been detected on the specified line.

L11L2 B8ZS DETECT — B8ZS line code is received on the specified line.

PRINT BUFFER FULL — Internal print buffers have overflowed. At least one printout has been lost (discarded).

PRINT SQUELCH ON — More than 20 alarm or status prints have been generated within one minute. The printer squelch feature is enabled and no more messages or automatic ERR SEC results prints will print.

PRINT SQUELCH OFF — The generation of 5 or fewer alarm or status print requests or errored second result prints within a minute while the SQUELCH is ON causes SQUELCH to turn OFF.

TEST COMPLETE — The end of a timed test has been reached.

TEST RESTART — A test restart occurred.

NEW CONFIGURATION — The configuration of the T-BERD 224 has been modified.

5.4 OPERATING WITH THE OPTIONAL LID PRINTER

The optional thermal lid printer is contained within the T-BERD 224 front panel cover and mounts on the T-BERD 224 front panel with a hinge on the bottom front edge of the unit. The power, data, and control leads are supplied through the front panel **AUXILIARY PORT** connector on the lower left side of the front panel.

The lid printer is a thermal dot-matrix printer that provides 40-column printouts. The data input for the printer is serial asynchronous data operating at 9600 b/s with a character format of 1 start bit, 8 data bits, and no parity.

NOTE: Do not operate the lid printer when the cover is closed.

5.4.1 Lid Printer Controls and Indicators

The lid printer's **ON LINE** and **PAPER FEED** pushbutton switches are the only controls on the printer. The **ON LINE** switch illuminates green when the printer is ready to print. Press the **ON LINE** switch to take the printer on and off line. Pressing the **PAPER FEED** switch advances the paper when the printer is off line. The lid printer automatically goes off line when the T-BERD 224 is under remote control.

5.4.2 Lid Printer Connector

The lid printer connector is located on the lower left corner of the front panel and is labeled **AUXILIARY PORT**. The connector is an 8-pin RS-232-C serial port that supplies power, control, and data leads to the lid printer.

5.4.3 Set-Up and Operation

To set up the lid printer for operation, perform the following steps.

SECTION 5

- (1) If the printer is not connected to the T-BERD 224, turn the mainframe power OFF and plug the lid printer connector into the T-BERD 224 AUXILIARY PORT interface located on the lower left side of the front panel.
- (2) Press the **POWER** switch to apply power to the T-BERD 224. When power is first applied to the printer the **ON LINE** switch illuminates.

5.4.4 Loading the Printer Paper

When the printer is out of paper, the **PAPER FEED** switch illuminates red. A 4-3/8" wide roll of thermal paper fits inside the printer paper tray. The roll cannot exceed 1-3/4" in outside diameter and 7/16" in inside diameter to accept the paper retaining rod. Perform the following procedure to load a new roll of paper.

- (1) Remove any leftover paper out of the printer paper slot by pressing the **ON LINE** switch to extinguish the internal LED and pressing the **PAPER FEED** switch until the paper clears the print head.
- (2) Gently lift the smoked plastic paper tray cover from the printer cover.
- (3) Pull the paper tube and white retaining rod out of the paper tray. Slide the retaining rod out of the spent paper tube.
- (4) Slide the new roll of paper over the white retaining rod and remove the tape from the end of the paper. Make sure the end of the paper has a clean square cut on it.
- (5) Position the roll of paper over the paper tray with the end of the paper coming from under the roll. When the roll is placed in the tray, the end of the paper should be at the front of the tray with the shiny side of the paper facing out and the end of the paper pointed at the mainframe front panel.
- (6) Place the roll of paper (with the retaining rod in place) into the printer paper tray. Press down on each end of the roll until the retaining rod snaps into the notches on each side of the paper tray.
- (7) Unroll about 3 inches of paper and loop the end of the paper toward the front of the printer. The dull side of the paper should be facing up.

- (8) Look down inside the front edge of the paper tray and locate the paper feed slot located about 3-3/4" from the top of the printer cover.
- (9) Slide the end of the paper into the slot and press the **PAPER FEED** switch several times until the paper is protruding through the paper slot in the top of the printer.
- (10) Press the **ON-LINE** switch to illuminate the LED and place the printer back on line.

5.5 PRINTER CONNECTIONS

The RS-232 Connector enables you to obtain hard-copy printouts of test results, status messages, and front panel set-ups.

The RS-232 Connector is located on the side panel of the T-BERD 224. The connector is configured as Data Communications Equipment (DCE), which allows it to be directly connected to Data Terminal Equipment (DTE). Connection to other DCE, such as a modem, is possible with the use of a DTE/DCE adaptor cable. Table 5-1 shows the selections available for configuring the RS-232 Connector and Table 5-2 shows the configuration for the PR-40A printer.

Table 5-1
RS-232 Printer/Remote Control Interface Configuration

Connector:	25-pin, D-type, female.
Baud Rates:	300, 1200, 2400, 4800, or 9600.
Word Length:	7 or 8 bits.
Parity:	Odd, Even, or None.
Line Terminator:	CR, LF, or CRLF.
Timing:	Asynchronous.
Format:	Serial ASCII.
Column Width:	80 characters.
Interface Configuration:	AUX 08 RS232 function.

Table 5-2
PR-40A Printer Configuration

Baud Rate:	2400.
Line Terminator:	CR.
Parity:	None.

5.5.1 RS-232 Pin Configuration

To provide maximum operative flexibility, the use of RS-232 signaling leads has been minimized. When the T-BERD 224 has data to output to the RS-232 port, the state of the receiving devices DTR line is checked. When this line is set HIGH by the device, the T-BERD 224 assumes the device is ready to accept a byte of data. Table 5-3 lists the RS-232 pin configuration.

Table 5-3
RS-232 Connector Pin Assignments

Pin #	Signal Description	Function
1	Protective Ground	Connects to chassis ground.
2	Transmit Data (TXD)	The T-BERD 224 receives data on this lead.
3	Receive Data (RCV Data)	The T-BERD 224 transmits data on this lead.
4	Request to Send (RTS)	This lead is ignored by the T-BERD 224.
5	Clear to Send (CTS)	This lead is driven to the ON state by the T-BERD 224 whenever it is ready to receive a command. This lead maybe ignored by the controller if, before issuing commands, it waits for the return of a prompt character from the T-BERD signifying the completion of the previous command.

Table 5-3
RS-232 Connector Pin Assignments (Continued)

Pin #	Signal Description	Function
6	Data Set Ready (DSR)	The T-BERD 224 drives this line to the ON (HIGH) state whenever it is powered ON.
7	Signal Ground	Connected to signal ground.
8	Received Line Signal Detector (RSLD)	Must be ON before the T-BERD 224 will accept any data.
9	Pos. DC Test Voltage	This lead provides +12 VDC (RS-232 ON) for use in strapping signaling leads ON.
10	Neg. DC Test Voltage	This lead provides -12 VDC (RS-232 OFF) for use in strapping signaling leads OFF.
12	Sec RLSD	The T-BERD 224 drives this lead ON (HIGH) whenever data in its FIFO is ready to print.
20	Data Terminal Ready (DTR)	When this lead is driven ON (HIGH) by the receiving device (e.g., printer), the T-BERD 224 transmits data.

SECTION 5

REMOTE CONTROL OPERATION

6.1 INTRODUCTION

This section describes the T-BERD 224 remote control capabilities. The PRINTER/REMOTE RS-232 connector lets the T-BERD 224 be remotely controlled from a terminal or a computer, while the PRINTER/REMOTE IEEE 488 connector allows remote control from a computer. Under remote control operation, the instrument's front-panel switches (except for the **RESULTS I** and **RESULTS II Category** and **RESULTS Results** switches) are disabled. The **RESULTS** switches can be disabled by using the DISPLAY REMOTE remote command. See Section 6.5.2 for more information. The message UNDER REMOTE CONTROL is flashed in the display while in REMOTE mode.

NOTE: The IEEE-488 Remote Control Interface is an optional feature.

6.2 RS-232 REMOTE CONTROL OPERATION

The PRINTER/REMOTE RS-232 connector enables the user to remotely control the T-BERD 224 from a terminal or computer. The PRINTER/REMOTE RS-232 connector is configured to function as Data Communication Equipment (DCE); it may be directly connected to Data Terminal Equipment (DTE). Connection to other DCE is possible with the use of an adaptor cable. This PRINTER/REMOTE RS-232 connector is a 25-pin female D connector located on the T-BERD 224's right-side panel. Auxiliary functions are used to select the baud rate, parity, and line terminator. Table 6-1 shows the selections available for configuring the PRINTER/REMOTE RS-232 connector.

6.2.1 RS-232 Pin Configuration

To provide maximum operative flexibility, the use of RS-232 signaling leads has been minimized. When the T-BERD 224 has data to output to the PRINTER/REMOTE RS-232 connector, the state of the receiving device's DTR line is checked. When this line is set HIGH by the device, the T-BERD 224 assumes the device is ready to accept a byte of data. Table 6-2 lists the RS-232 connector pin configuration.

Table 6-1
PRINTER/REMOTE RS-232 Connector Configuration

Connector:	25-pin, D-type, female.
Baud Rates:	300, 1200, 2400, 4800, or 9600.
Word Length:	7 or 8 bits.
Parity:	Odd, Even, or None.
Line Terminator:	CR, LF, or CRLF.
Timing:	Asynchronous.
Format:	Serial ASCII.
Column Width:	80 characters.
Interface Configuration:	Auxiliary Function 08.

Table 6-2
RS-232 Connector Pin Assignments

Pin #	Signal Description	Function
1	Protective Ground	Connects to chassis ground.
2	Transmit Data (TXD)	The T-BERD 224 receives data on this lead.
3	Receive Data (RCV Data)	The T-BERD 224 transmits data on this lead.
4	Request to Send (RTS)	This lead is ignored by the T-BERD 224.
5	Clear to Send (CTS)	This lead is driven to the ON state by the T-BERD 224 whenever it is ready to receive a command. This lead maybe ignored by the controller if, before issuing commands, it waits for the return of a prompt character from the T-BERD 224 signifying the completion of the previous command.
6	Data Set Ready (DSR)	The T-BERD 224 drives this line to the ON (HIGH) state whenever it is powered ON.

Table 6-2
RS-232 Connector Pin Assignments (Continued)

Pin #	Signal Description	Function
7	Signal Ground	Connected to signal ground.
8	Received Line Signal Detector (RSLD)	Must be ON before the T-BERD 224 will accept any data.
9	Pos. DC Test Voltage	This lead provides +12 VDC (RS-232 ON) for use in strapping signaling leads ON.
10	Neg. DC Test Voltage	This lead provides -12 VDC (RS-232 OFF) for use in strapping signaling leads OFF.
12	Sec RLSD	The T-BERD 224 drives this lead ON (HIGH) whenever data in its FIFO is ready to print.
20	Data Terminal Ready (DTR)	When this lead is driven ON (HIGH) by the receiving device (e.g., printer), the T-BERD 224 transmits data.

6.2.2 Remote Control Modes

When operating in remote control, the T-BERD 224 functions in either TERMINAL mode, REMOTE mode, or COMPUTER mode. The TERMINAL mode is for use by a person running an interactive communications package on a dumb terminal that is directly connected to the T-BERD 224. The REMOTE and COMPUTER modes allow a remote computer directly connected to the T-BERD 224 to control it.

TERMINAL mode is characterized by (1) providing a prompt character whenever the T-BERD 224 is ready to receive a command, (2) echoing all characters back to the remote device as the user types them, and (3) transmitting error messages when an improper command or syntax error occurs. The COMPUTER mode and REMOTE mode are characterized by the elimination of program interruptions (e.g., extra linefeeds, error messages, etc.), which allow the remote computer to quickly process responses.

SECTION 6

The T-BERD 224 powers up in LOCAL mode and remains there until a command is entered from either the RS-232 or IEEE-488 PRINTER/REMOTE connector. While in LOCAL mode, alarm prints are enabled, and printouts requested by the **PRINT EVENT** switch are not held.

If the T-BERD 224 is in Local mode and a remote control command is received that does not set one of the remote modes, the default remote control settings are used: ECHO is off and PROMPT is off. Automatic prints and error messages are sent to the controlling device. In addition, the lid printer is turned OFF LINE. After entering a remote mode, the "LOCAL" command returns control of the T-BERD 224 to the front panel.

6.2.3 Set-Up for Remote Control Operation

Prior to entering any RS-232 Remote Control mode, the baud and parity must first be set so that the T-BERD 224 is configured to communicate with the remote controller. Baud and parity can be configured by:

- Manually using the BAUD and PARITY Auxiliary Function 08 (RS 232).
- Automatically using the auto baud function.

Manual Set-Up for Remote Control Operation

Use the procedure in Table 6-3 to manually set the baud rate, termination, and parity to match the settings of the intended remote control device.

Automatic Set-Up for Remote Control Operation

The auto baud function allows baud, data bits, and parity values to be automatically configured. The auto baud function offers possible baud rate settings of 300, 1200, 2400, 4800, and 9600 and possible parity settings of even, odd, or none.

To establish communication with the remote control unit through the auto baud function, perform the procedure in Table 6-4.

Table 6-3
Manual Remote Control Operation Set-Up

Step	Activity
1.	With Auxiliary Function 08 selected, use the RESULTS I Category switch to set the baud rate to match the remote control device baud rate. (Baud rate can be set to 300, 1200, 2400, 4800, or 9600.)
2.	Use the RESULTS II Results switch to select the termination. (Termination can be set to CR, LF, or CRLF.)
3.	Use the SCII switch to select the parity. (Parity can be set to ODD, EVEN, or NONE.) NOTE: When PARITY is set to ODD or EVEN, the number of data bits equals 7; when PARITY is set to NONE, the number of data bits equals 8.

Table 6-4
Automatic Remote Control Operation Set-Up

Step	Activity
1.	Press the BREAK key twice slowly (once per second). (On some terminals, the CTL key and the BREAK key must be pressed simultaneously.)
2.	Press and hold the space bar until the message, "Auto-baud achieved. Press ESCAPE to continue" appears. (If the space bar does not have an auto-repeat function, press the space bar repeatedly until the message appears.)
3.	Press the ESCAPE key once: the message "Character format determined" is displayed. NOTE: The auto baud function must be completed within 30 seconds. If auto baud is not acquired within the 30-second period, the auto baud function is aborted and a message is printed.

SECTION 6

6.2.4 REMOTE Mode Operation

Once the T-BERD 224 is properly configured to communicate with the controller, the T-BERD 224 is placed into the REMOTE mode by sending (typing) a valid remote command or by pressing the period (".") key followed by a terminator (CR or CRLF). The terminator recognized by the T-BERD 224 is defined by Auxiliary Function 08 (see Section 6.2.3.1). Typing a period sets the T-BERD 224 for terminal (CRT) control. When the T-BERD 224 is to be controlled by a computer through the RS-232 port, the "REMOTE" command should be used.

When under REMOTE mode, to make the passing of responses easier, character echoing, prompts, error messages, and results, controls, status, and alarm prints are all disabled. The results, controls, status, and alarms prints can all be released by use of the "REL" command. When REMOTE mode is enabled, the lid printer is turned OFF LINE.

The equivalent of the following commands are executed:

"ECHO OFF"
"PROMPT OFF"
"MESSAGES OFF"
"HOLD"

Once a valid command is recognized by the T-BERD 224, it is placed in the REMOTE mode. In REMOTE mode, the printer output is sent to the controlling device, the message "UNDER REMOTE CONTROL" is flashed in the left display window, and the front panel switches are disabled.

6.2.5 TERMINAL Mode Operation

The following procedure describes how to operate the T-BERD 224 from a dumb terminal or computer that is operating in an interactive TERMINAL mode.

Place the T-BERD 224 into TERMINAL mode by typing a period "." or "TERMINAL" and then a valid terminator (CR, LF, or CRLF) from the remote device.

When in TERMINAL mode, the input characters are echoed back to the terminal so that the user can see what is being typed. Also each line of input

is prompted by either the default prompt ">" or a user defined prompt, which can be up to 100 characters in length. Automatic prints (generated by the **PRINT EVENT** switch) and alarm and status messages are sent to the terminal. When **TERMINAL** mode is enabled, the lid printer is placed **OFF LINE**.

The equivalent of the following commands are executed:

"ECHO ON"
"PROMPT ON"
"ALARM ON"
"MESSAGES ON"
"RELEASE"

This series of commands places the T-BERD 224 in remote control mode and locks out the front panel switches, except **RESULTS I** and **RESULTS II Category** switches. The following message is printed on the terminal to indicate that the T-BERD 224 is in **TERMINAL** operating mode:

Terminal mode initiated.
Type "HELP" followed by a <RETURN> for help.
>

Operating in TERMINAL Mode

The prompt (>) signifies that the T-BERD 224 is ready to accept commands and is in an interactive **TERMINAL** mode with the remote device. In **TERMINAL** mode, the prompt, echo, and error messages functions are enabled.

Unless specified otherwise, sending a command that requires a response from the T-BERD 224, causes the information to be printed. This includes the appropriate status messages, prompts, extra linefeeds, character echo, or error messages. The responses returned are indicated by the **EXAMPLE** for the remote commands.

Each command sent must have the proper syntax and line terminator before the command is accepted as being valid. If an invalid command is received, the T-BERD 224 responds by printing an error message. Error messages are listed in Section 6.4.

SECTION 6

Prompts in TERMINAL Mode

Three prompts are generated by the T-BERD 224 while in TERMINAL mode. These prompts are: default, user defined, and printer hold. The default prompt is the greater than symbol (>). The default prompt appears when the T-BERD 224 is first placed in TERMINAL mode. A user-defined prompt (up to 100 characters) can be generated to replace the default prompt symbol. The user-defined prompt is created by sending the command **PROMPT STRING XXXX** (where XXXX are ASCII characters). This can also be used to create a prompt that identifies the T-BERD 224 to which the terminal is attached. A user-defined prompt is not saved when the T-BERD 224 power is turned OFF. The printer hold prompt is the plus symbol (+) and appears in response to the **HOLD** command. The plus symbol indicates that the printer buffer is not sending printouts to the terminal. Sending the **REL** command releases the printer hold, allowing printouts to be generated again and returns the prompt to its pre-hold state.

6.2.6 COMPUTER Mode Operation

The COMPUTER mode is identical to the REMOTE mode, except that if a terminator is received by the T-BERD 224 before it is finished transmitting the output of the previous command, the output is terminated and the new command is executed. This is used to prevent output from commands for which output is not expected. When COMPUTER mode is enabled, the lid printer is turned OFF LINE.

NOTE: COMPUTER mode is the only remote control mode available from an IEEE-488 controller.

The equivalent of the following commands are executed:

“ECHO OFF”
“PROMPT OFF”
“MESSAGES OFF”
“HOLD”

6.2.7 Terminating Remote Control Operation

To end any remote operating mode and return the T-BERD 224 to local control, send either “**LOCAL**” or “/” followed by a valid termination. The

T-BERD 224 front panel controls are returned to local control and the message "UNDER REMOTE CONTROL" is no longer visible in the display window.

NOTE: Turning the unit power OFF also aborts a remote operating mode. The remote operating mode may be changed at any time by using one of the mode commands: **TERMINAL**, **COMPUTER**, or **REMOTE**.

6.3 IEEE-488 INTERFACE

The optional **PRINTER/REMOTE IEEE-488** connector allows the T-BERD 224 to be connected to an IEEE-488 bus. With the **PRINTER/REMOTE IEEE-488** connector selected, two operating modes are selectable: talk-only and addressable. Auxiliary Function 09 (**488MODE**) is used to select the IEEE-488 operating mode and address. Selecting **TALK-ONLY** configures the T-BERD 224 to directly drive a listen-only device, such as a printer. In the talk-only mode, the T-BERD 224 only outputs data to the **PRINTER/REMOTE IEEE-488** connector and cannot be controlled by a remote device. In the addressable mode, the T-BERD 224 IEEE-488 bus address (a value between 0 and 31) must be set in **AUX 09**. Using the T-BERD 224 address, the controller can designate the T-BERD 224 to "listen" (receive remote commands) or to "talk" (send data).

With the IEEE-488 Option installed, selection of the printer/interface port is handled automatically. A check is made of the printer/interface port and if **AUX 09** is set to **TALK ONLY** or the IEEE-488 port is addressed by a controller, the IEEE-488 port is selected as the printer port. If these criteria are not met, then the **PRINTER/REMOTE RS-232** connector is selected.

6.4 ERROR MESSAGES

Most error messages contain the prefix **ERROR** and are terminated by a **CR**, **LF**, or **CRLF** sequence, as selected by Auxiliary Function 08 (see Section 2.5).

Error messages are only output when the "MESSAGES" command is set to "ON". If error messages are not desired but the user would like to know

SECTION 6

if there has been an error in a command, the "MESSAGES OFF" command disables the printing of the error messages and the "ERR NUM?" command returns the error number of the most recent error. For example, if the user sent the following commands:

```
> MESSAGES OFF
> MOD T1D4
> COD ZMI ; Invalid parameter - should be AMI
> PRI EVE OFF
> TES CON
> ERR NUM?
```

The response to the ERR NUM command is:

```
ERRor NUMBER 2
```

Error number 2 (Unrecognized parameter) was the most recent error that occurred. In the third command, COD ZMI, the ZMI portion was incorrect. No message was printed immediately after the COD AMI was entered because "MESSAGE OFF" command had been sent previously and this command disabled the error messages. Sending a second error query (ERR NUM?) returns the no error indication (ERRor NUMBER 0), since no errors occurred since the last call to "ERR NUM?". Thus:

```
> ERR NUM?
ERRor NUMBER 0
```

The following is a list of the possible error messages in the numerical sequence used by the ERR NUM command and a brief explanation of what may have caused the error.

ERROR: *Unrecognized command.*

A command name entered in the command line is not recognized.

ERROR: *Unrecognized parameter.*

The command is recognized but the specified command parameter cannot be interpreted.

ERROR: *Characters after statement end.*

Additional characters were detected after the end of a valid command.

ERROR: *Command not currently valid.*

An invalid command was entered for the current test configuration.

ERROR: *RS-232 receiver parity error.*

One or more characters were received with parity errors.

ERROR: *RS-232 receiver overrun error.*

The remote control device is sending characters to the T-BERD 224 while the CTS (Clear To Send) control signal is OFF (false) and XOFF has been sent, indicating that the T-BERD 224 is not ready for more data.

ERROR: *RS-232 receiver framing error.*

One or more asynchronous framing errors were detected in the input command (possibly resulting from the controller format being different from the T-BERD 224's format).

ERROR: *Receiver buffer overflow.*

A command is greater than 512 characters in length or commands were entered too quickly.

ERROR: *Parameter is out of range.*

A parameter value was specified that is out of the valid range (e.g., entering 32 as the value for the day).

ERROR: *No such help page.*

A HELP page was requested that does not exist.

ERROR: *Must be followed by a parameter.*

A required parameter for the execution of the command was not specified.

ERROR: *Command not executable. — End with "\?" for status.*

A command was attempted to be executed for which only a status exists (i.e., SETUP) and requires a "?" as a parameter.

ERROR: *Command has no status.*

The status of a command has been requested that has no status (i.e., RESTART?).

ERROR: *Reserved for future use.*

ERROR: *Reserved for future use.*

ERROR: *Selection is not applicable.*

An invalid setting was attempted. Refer to Section 5.7 for the valid settings.

ERROR: *Option not installed.*

A command was sent that requires an option that is not presently installed in the unit.

SECTION 6

ERROR: *DSU-DP Option not installed.*

A command was requested which requires the DSU Data Port Option, which is not installed.

ERROR: *Reserved for future use.*

ERROR: *IEEE 488 Option not installed.*

A command was requested which requires the IEEE-488 Option, which is not installed.

ERROR: *BERT Option not installed.*

A command was requested which requires the BERT Option, which is not installed.

ERROR: *VF Option not installed.*

A command was requested which requires the VF Option, which is not installed.

ERROR: *SLC/ESF Option not installed.*

A command was requested which requires the Enhanced SLC-96 and ESF Option, which is not installed.

ERROR: *ZBTSI Option not installed.*

A command was requested which requires the ZBTSI Framing Option, which is not installed.

ERROR: *BERT or DSU/DP Option not installed.*

A command was requested which requires either the BERT or DSU-DP Option, which is not installed.

ERROR: *Reserved for future use.*

ERROR: *Reserved for future use.*

ERROR: *Reserved for future use.*

ERROR: *The other result window is currently displaying traffic.*

The TRAFFIC result was requested when the other result window is already displaying TRAFFIC (n56).

ERROR: *Reserved for future use.*

ERROR: *BERT, DSU-DP, or SLC/ESF Option not installed.*

A command was requested which requires the BERT, DSU-DP, or Enhanced SLC-96 and ESF Option, which is not installed.

6.5 REMOTE CONTROL COMMANDS

This section presents the formats and entry sequence for remote control commands, as well as an alphabetical list of all the remote control commands. For each command there is an explanation of the command, references to associated commands, and a brief example of command usage.

Three primary command types are available with the T-BERD 224 remote control facility:

- Switch commands set the T-BERD 224 front-panel switches.
- Auxiliary commands set the T-BERD 224 auxiliary functions.
- Control commands pertain exclusively to the RS-232 Printer/Remote Control Interface.

These command sets are fully described in Section 6.5.2.

6.5.1 Command Formats And Entry Sequence

The general format for any remote control command is:

```
command_name [parameter] or  
command_name?
```

The `command_name` entry specifies the name of the command to be executed (all remote control commands are fully described in Section 6.5.2). Where possible, commands which represent a front-panel or auxiliary activity are abbreviated to reflect the first three characters of the switch or function, however more characters may be typed if desired. Control commands have no front-panel equivalent. The on-line help feature displays the required characters in UPPER CASE and the optional characters in lower case.

The `[parameter]` entry specifies any parameter(s) associated with the command. Any parameter should be separated from the command name by at least one space. The command name parameter string should always be followed by a carriage return or carriage return/line feed sequence.

Most remote control commands can be used to select a new command state or to display the current command state (without changing it). To select

SECTION 6

a new command state, enter both the command name and the desired parameter on the command line. To display the current state, enter the command name only followed by a question mark (?). Note, however, that some commands (e.g., CLS) are “executable only” and have no current or changeable state.

NOTE: With the exception of the HELLO, RS232, SETUP, and LEDS commands, all commands without brackets are “executable only” and have no status to return (e.g., RS232?).

Switch Commands Format

Switch commands control the functions normally associated with the T-BERD 224 front panel. Mnemonics represent the first three characters of the switch name or switch position as it appears on the T-BERD 224 front panel and in the display.

Table 6-5 lists the switch commands along with their equivalent front-panel switch names. Brackets to the right of the switch name indicate the availability of associated parameters. The parameters associated with each command are fully described in Section 6.5.2.

Table 6-5
Switch Commands

Command	Switch
CHA FOR []	CHANNEL FORMAT
COD []	CODE
CON	CONTROLS
DIS HOL []	DISPLAY HOLD
DRO []	DROP
ERR INS BPV[]	BPV ERROR INSERT
ERR INS FRA[]	FRAME ERROR INSERT
ERR INS YEL[]	YELLOW ALARM ERROR INSERT
HIS RES	HISTORY RESET
INS []	INSERT
L1 CHA []	LINE 1 CHANNEL

**Table 6-5
Switch Commands (Continued)**

Command	Switch
L2 CHA []	LINE 2 CHANNEL
L1 REC INP []	LINE 1 RECEIVE INPUT
L2 REC INP []	LINE 2 RECEIVE INPUT
MOD []	MODE
PRI []	PRINT
PRI EVE []	PRINT EVENT
RES 1 []	RESULTS 1
RES 2 []	RESULTS 2
RESTART	RESTART
RESULTS	RESULTS
SIG INS A []	SIGNALING INSERT A
SIG INS B []	SIGNALING INSERT B
SIG INS C []	SIGNALING INSERT C
SIG INS D []	SIGNALING INSERT D
SIG INS ALL []	SIGNALING INSERT ALL
SOU 1 []	SOURCE CONFIGURATION I
SOU 2 []	SOURCE CONFIGURATION II
TES []	TEST
VOL []	VOLUME

Auxiliary Function Commands Format

Auxiliary commands control the functions normally associated with the T-BERD224 AUX mode. Table 6-6 lists the auxiliary function commands along with their equivalent AUX mode names. Brackets ([]) following the command name indicate the command has associated parameters. The parameters with each command are fully described in Section 6.5.2.

Control (Non-Switch) Commands Format

Control commands have no front panel or AUX equivalent. These commands are used to obtain information from the T-BERD 224 or to modify the remote control/printer protocol. Table 6-7 lists the control commands. Brackets following the command name indicate that the command has associated parameters. The parameters with each command are fully described in Section 6.5.2.

**Table 6-6
Auxiliary Function Commands**

Command	Auxiliary Function
BAC TIM []	AUX 06
CLEAR FIFO	AUX 01
CLO []	AUX 04
DAT []	AUX 04
DS0 INTF TIM []	AUX 07
L1 LBO []	AUX 05
L2 LBO []	AUX 05
PRI TER []	AUX 08
RS232	AUX 08
TES LEN []	AUX 03
TIM PRI EVE	AUX 02

**Table 6-7
Control Commands**

ALA []	HOL
CLS	LED
COM	L1 REC SIG []
DEVICE CLEAR	L2 REC SIG []
DIS []	LOCA (/)
ECH []	MES []
ERR NUM	PRO
FIRST P U	REL
HELL	REM
HELP []	SET
	TER (.)

Input Sequence

A remote command consists of an ASCII character string followed by either a carriage return (CR), a line feed (LF), or a carriage return/line feed (CRLF). When specifying a remote control command, the following rules apply:

- (1) Commands may be entered in either upper case or lower case.
- (2) A space must be inserted between the command name and a parameter.
- (3) Entering a CTL C (Control C) or a CTL X (Control X) prior to issuing a CR or LF cancels the input line. (CTL C also aborts all printing.)
- (4) Entering a CTL H (Control H) or a BACK SPACE erases the last character entered. This is available for RS-232 controllers only.
- (5) Up to 20 previously entered commands can be recalled by using the ESC key. When the number of previously sent commands exceeds 20, the earliest command entries are overwritten. This is available for RS-232 controllers only.

After receiving a carriage return or a carriage return/line feed sequence, the T-BERD 224 analyzes the data in its input buffer. It checks the data for parity, overrun, framing, overflow, and syntax errors. If any error is detected, the appropriate error message is returned to the controller. If no error is detected, the command is decoded and the appropriate response is generated.

If the ECHO feature is enabled, the entered character string is echoed back to the controller. If the PROMPT command is enabled, the default prompt (“>”) or a user-defined prompt (of a single character or a string) is used to indicate that the previous command has been processed and that the T-BERD 224 is ready to accept additional commands.

NOTE: The TER command automatically enables ECHO and PROMPT when the remote control mode is entered. With either the PROMPT or ECHO feature enabled, any characters used to cancel a line are echoed to the remote control unit. The prompt and echo features are only applicable for RS-232.

SECTION 6

Output Sequence

The following rules apply for output sequence:

- (1) All remote control output has a higher priority than printer output. This means that printer output is halted (suspended) if any remote control output is available in response to a command. Printer output resumes when the remote control output has been sent.
- (2) The HOL command suspends the printer output until the REL (release) command is sent. When the HOL command is sent and the prompt is ON, the prompt character automatically changes to a "+" to indicate that data is waiting to be printed. After the REL command is sent if the prompt is ON, the default prompt (>) or the user-defined prompt is returned. Note that the remote control output is not held.
- (3) CTL S suspends all output. Sending a CTL Q (Control Q), releases the printer output suspended by the CTL S. These control characters only apply for RS-232.
- (4) Sending a CTL C (Control C) clears the entire printer FIFO.

6.5.2 T-BERD 224 Remote Control Commands by Group

Table 6-8 lists the T-BERD 224 remote control commands in alphabetical order. A detailed discussion of each remote control command follows Table 6-8 and presents an explanation of the command, references to associated commands, and a brief example of command usage.

Table 6-8
T-BERD 224 Mainframe Remote Control Commands

Command	Parameters	Command Name
ALA	?IONIOFF	Alarm Message Prints
BAC TIM	?IINTIEXT	Backup Timing
CHA FOR	?I(channel)	Channel Format

**Table 6-8
Remote Control Commands (Continued)**

Command	Parameters	Command Name
CLEAR FIFO		Clear the Print FIFO
CLO	? hh:mm:ss	Clock Time
CLS		Clear the Terminal Screen
COD	? AM B8Z	Select Code Type
COM		Configure for Computer Remote Control Operation
CON		Generate a Controls Printout
DAT	? MM-DD	Calendar Date
DEVICE CLEAR		Re-initialize Device
DIS	? LOCAL REMOTE	Front Panel Display Mode
DIS HOL	? ON OFF	Freeze the Results Displays
DRO	? L1 L2 BOT	Drop Channel
DS0 INT TIM	? SEPI COM	DS0 Interface Timing
ECH	? ON OFF	Echo Mode
ERR INS	BPV? FRA? YEL? BPV [OFF SIN] FRA [OFF SIN] YEL [ON OFF]	Error Insertion
ERR NUM	?	Error Number
FIRST P U		First Power-Up
HELL	?	Display the Software Revision Level
HELP	!!HELP <number> <command-name>	On-Line Help Function
HIS RES		Reset Alarm History LEDs
HOL		Hold All Printer Outputs
INS	? L1 L2 NON	Insert
L1 CHA	? nn ALL - -	LINE 1 Channel Selection
L1 LBO	? 0 -7.5 -15	LINE 1 Line Build-Out

SECTION 6

**Table 6-8
Remote Control Commands (Continued)**

Command	Parameters	Command Name
L1 REC INP	? BRI TER DSX	LINE 1 Receive Input Termination
L1 REC SIG	?	LINE 1 Receive Signal Status
L2 CHA	? nn ALL -	LINE 2 Channel Selection
L2 LBO	? 0 -7.5 -15	LINE 2 Line Build-Out
L2 REC INP	? BRI TER DSX	LINE 2 Receive Input Termination
L2 REC SIG	?	LINE 2 Receive Signal Status
LED	?	LED Status
LOCA (/)		Return the T-BERD 224 to Local Mode
MES	? ON OFF	Enable or Disable Error Message Printing
MOD	? (mode)	Transmit and Receive Mode
PRI	CON RES valid result name	Initiate Printout
PRI EVE	? ERR SEC OFF TES END TIM	Print Event
PRI TER	? CR CRLF FILF	Printer Terminator
PRO	? ON OFF STRING (prompt-string)	Remote Control Prompt
REL		Release Printer Hold
REM		Remote Control Entry
RES	1 (result name) 2 (result name) 1? 2?	Result Display Control
RESTART		Restart Test
RESULTS		Results Printout
RS232	?	RS-232 Parameters
SET	?	Setup Summary

Table 6-8
Remote Control Commands (Continued)

Command	Parameters	Command Name
SIG INS	A? B? C? D? ALL? A [OFF ON] B [OFF ON] C [OFF ON] D [OFF ON] ALL [XX XXXX]	Channel Signaling Bit Insert
SOU 1	? (parameter)	Source Configuration I
SOU 2	? (parameter)	Source Configuration II
TER	(.)(period)	Configure for Terminal Control
TES	? TIM CON	Test Results Accumulation
TES LEN	? HHH:MM:SS	Test Length
TIM PRI EVE	? H:MM:SS	Time Print Event
VOL	? ON OFF	Loudspeaker Control

SECTION 6

ALA

ALA

Alarm Message Prints

ALARM? :Print the status of the alarm message
ALA [ON|OFF] :Enables or disables alarm message prints

ALARM? requests the alarm message print status. **ALARM [ON|OFF]** is used to enable or disable the printing of alarm messages. When ON is selected alarm messages are printed. Selecting OFF disables the alarm messages, preventing alarm and status messages from being printed. When the PRI EVE command is OFF, the **ALARM ON** command has no effect because no printouts are enabled.

EXAMPLE:

> **ALARM?** :display the current alarm status
ALARMs ON
> **ALARM OFF** :disable alarm message prints
>

BAC TIM

BAC TIM

Backup Timing

BAC TIM? :Displays the status of backup timing
BAC TIM [INT|EXT] :Set the backup timing source

BAC TIM sets or returns the current backup timing source which is used when the clock for the selected line is not recoverable. **BAC TIM INT** selects the fixed internal crystal oscillator as the timing source. **BAC TIM EXT** selects a clock connected to the side panel BNC connector as the timing source. **BAC TIM EXT** requires an external reference at the BNC input connector.

This command is identical to the AUX 06 BACK TIM function.

EXAMPLE:

```
> BAC TIM?           :display the current backup timing source
  BACKup TIMing INTernal
> BAC TIM EXT       :selects external as the backup timing source
>
```

SECTION 6**CHA FOR****CHA FOR****Channel Format**

CHA FOR? :Displays the current channel format
CHA FOR (channel) :Sets the channel format

CHA FOR sets the current channel format for the T-BERD 224. The channel format selections are:

VF :Voice Frequency
VF THR :Voice Frequency with Through Signaling
DS0 :Digital Signal Level 0

NOTE: Changing the channel format causes a test restart and may change the current setup.

EXAMPLE:

> **CHA FOR?** :display the current channel format
CHAnnel FORmat VF THRU
> **CHA FOR DS0** :select DS0 as the channel format

WARNING: New Setup:
MODE T1D4
CHAnnel FORmat DS0
SOURce 1 BYTe
SOURce 2 10101010
>

CLEAR FIFO

CLEAR FIFO

Clear the Print FIFO

CLEAR FIFO

CLEAR FIFO command clears the print FIFO of all printouts that are awaiting printing.

This command is identical to the AUX 01 CL FIFO function.

EXAMPLE:

> CLEAR FIFO :clear the print FIFO

>

SECTION 6**CLO****CLO**

Clock Time

CLO? :Display the clock time (time of day)
CLO hh:mm:ss :Set the clock time

CLO sets or returns the clock time. The time is entered in 24-hour format; seconds are always set to zero when a new time is entered.

This command is identical to the AUX 04 TIME/DAY function.

EXAMPLE:

```
> CLO? :print the clock time
CLOCK 15:30:24 :time is displayed in hours, minutes, and
                seconds
> CLO 6:28 :set clock time to 6:28 a.m.
>
```

CLS

CLS

Clear the Terminal Screen

CLS

:Clears the terminal screen

CLS enables you to output 30 of the selected line terminator sequences (usually CRLF for terminals) to your terminal. This has the effect of clearing the terminal screen of all previous outputs. This command is not available from the IEEE-488 port.

EXAMPLE:

> **CLS**

:clear the terminal screen

:30 line terminators transmitted

.
. .
. . .

v

SECTION 6**COD****COD****Select Code Type**

COD? :Display the current status of the **CODE** switch

COD [AMI|B8Z] :Set the line code type

COD selects or returns the current code type used by the T-BERD 224 when transmitting a T1 signal. When you select **AMI**, AMI coding is enabled; when you select **B8Z**, B8ZS coding is enabled. Note that received B8ZS sequences are always decoded.

EXAMPLE:

> **COD?** :display the current COD status
 CODE AMI
> **COD B8Z** :enable B8ZS line coding
>

COM**COM**

Configure the T-BERD 224 for Remote Control Operation

COM

:Sets the T-BERD to computer mode

COM configures the T-BERD 224 for computer remote control operation by automatically setting the following:

ECHO OFF	:turns echo off
PROMPT OFF	:turn command prompts off
PRI TERM CRLF	:line terminator set to carriage return and linefeed
HOLD	:holds printouts

This command is typically used when responses to queries are desired to be terminated. While in the computer mode, the next command aborts the output of any other command (e.g., LEDES) that have not yet finished. This command is the default for IEEE-488 operation.

SECTION 6

CON

CON

Generate a Controls Printout

CON :Displays the current status of the T-BERD 224 switches and auxiliary functions

CON allows you to initiate a printout of all current T-BERD 224 switch and auxiliary function settings. This command is functionally identical to pressing the **CONTROLS** position of the **PRINT** switch on the T-BERD 224's front panel.

The effect of this command is identical to issuing the **PRI CON** remote control command.

EXAMPLE:

```
> CON :generate a controls print
      :controls print follows
.
.
.
> :controls print ends
```

DAT

DAT

Calendar Date

DAT? :Display the date
DAT MM-DD :Sets the calendar date, where MM is the month and DD is the day

DAT MM DD is used to set the calendar date. Where MM is the number (1 to 12) of the month and DD is the number of the day (1 to 31). Invalid date settings are ignored.

Valid formats for setting the date are as follows:

MM/DD
 MM.DD
 MM DD
 MM,DD
 MM-DD

This command is identical to the AUX 04 TIME/DATE function.

EXAMPLE:

```
> DAT? :display the date
  DATE MAY 14
> DAT 1/14 :sets the date to January 14
>
```

SECTION 6

DEVICE CLEAR

DEVICE CLEAR

Reinitialize Device

DEVICE CLEAR

DEVICE CLEAR clears the T-BERD 224 by executing the power-up procedure. The entire instrument is reinitialized - hardware and RAM. NOVRAM is not cleared.

NOTE: When specified, this command returns control of the T-BERD 224 to the front-panel of the instrument. Remote control mode must be reestablished.

Modifying this command causes a test restart.

EXAMPLE:

> **DEVICE CLEAR** :execute instrument power-up
(no longer in remote control)

DIS**DIS****Front-Panel Display Mode**

DIS? :View current mode of display control
DIS [LOCAL|REMOTE] :Set display control

DIS determines whether the **RESULTS I** and **RESULTS II Category** and Results switches are active when the T-BERD 224 is under remote control. Note that all other switches are always inactive while in remote control.

DIS LOCAL activates the **RESULT** switches. (**DIS LOCAL** is the default for Remote Control mode.) **DIS REMOTE** disables the **RESULT** switches.

EXAMPLE:

> **DIS?** :view current mode of display control
DISPLAY LOCAL
> **DIS REMOTE** :disables the **RESULT** switches
>

SECTION 6

DIS HOL

DIS HOL

Freeze the Results Displays

DIS HOL? :Display the current status of **DISPLAY HOLD** switch
DIS HOL [ON|OFF] :Set **DISPLAY HOLD**

DIS HOL controls the front panel results displays. **DIS HOL ON** freezes the results displays. Note that when **DIS HOL ON** is enabled during a test, the T-BERD 224 continues to accumulate test results. **DIS HOL OFF** disables the display hold function.

This command is identical in function to the **DISPLAY HOLD** switch on the front panel of the T-BERD 224 (see Section 2.3.2 #6).

EXAMPLE:

> **DIS HOL?** :view current status of display hold
DISplay HOLD OFF
> **DIS HOL ON** :freezes the display
>

DRO

DRO

Drop Channel

DRO? :Display the status of the **DROP CHANNEL** switch

DRO [L1|L2|BOT] :Set the channel drop line

DRO returns or selects from which T1 signal a channel(s) is to be dropped for testing. **DRO L1** selects LINE 1, **DRO L2** selects LINE 2, and **DRO BOT** sets both LINE 1 and LINE 2 as the source from which the data is dropped.

Modifying this command causes a test restart.

EXAMPLE:

> **DRO?** :displays the current channel drop status

DROp L1

> **DRO BOT** :sets the drop channel to BOTH lines

>

SECTION 6**DS0 INT TIM****DS0 INT TIM****DS0 Interface Timing**

DS0 INT TIM? :Display the status of the DS0 interface timing

DS0 INT TIM [SEP|COM] :Set the DS0 interface timing

DS0 INT TIM controls the selection of the DS0 interface transmit and receive clocks. **DS0 INT TIM COM** selects a single clock for both drop and insert. **DS0 INT TIM SEP** selects separate clocks for drop and insert.

This command is identical to the AUX 07 DS0 TM function.

Modifying this command causes a test restart if **CHANNEL FORMAT** is set to DS0.

EXAMPLE:

> **DS0 INT TIM?** :displays the current DS0 interface timing status

DS0 INTF TIMing COMmon

> **DS0 INT TIM SEP** :sets the DS0 interface timing to separate

>

ECH

ECH

Echo Mode

ECH? :Display echo status
ECH [ON|OFF] :Set echo mode

ECH determines whether characters entered from the remote control unit are displayed.

ECH ON enables all characters entered from the remote control unit to be displayed. **ECH OFF** inhibits the printing of characters entered from the remote control unit. **ECHO** is not available from the IEEE-488 port.

EXAMPLE:

```
> ECH? :view echo status
  ECHO ON
> ECH OFF :turns echo off
> (CLOCK?) :CLOCK is specified - but not echoed
  CLOCK 12:03:32 :the time is displayed
>
```

SECTION 6**ERR INS****ERR INS****Error Insertion**

ERR INS BPV?	:Displays the status of the BPV insertion
ERR INS FRA?	:Displays the status of the frame error insertion
ERR INS YEL?	:Displays the status of the yellow alarm insertion
ERR INS BPV [OFF SIN]	:Insert a single BPV into the data stream
ERR INS FRA [OFF SIN]	:Insert a single frame error into the data stream
ERR INS YEL [ON OFF]	:Insert yellow alarm into the data stream

ERR INS displays or inserts the corresponding error into the T1 line selected using the **INSERT** command. **ERR INS BPV SIN** inserts a single BPV into the data stream. **ERR INS FRA SIN** inserts a single frame error into the data stream. **ERR INS YEL ON** inserts continuous yellow alarm into the data stream.

NOTE: After single BPV or frame errors are inserted, the status is returned to OFF. Yellow alarm insert remains ON until the **ERR INS YEL OFF** command is entered.

EXAMPLE:

```
> ERR INS BPV?           :display the current BPV error insertion
                           status
  ERRor INsert BPV OFF
> ERR INS FRA SIN       :Inserts a single frame error into the data
                           stream
>
```

ERR NUM

ERR NUM

Error Number

ERR NUM?

:Displays the code number for the most recent remote control command error

Prints the number of the most recent remote control command error. Refer to Section 6.4 for the list of error message numbers and explanations.

EXAMPLE:

> ERR NUM?
ERROR NUMBER 01

:Prints the number of the last error message.

>

SECTION 6

FIRST P U

FIRST P U

First Power-Up

FIRST P U :Resets NOVRAM to factory settings

FIRST P U reloads factory settings into non-volatile memory (NOVRAM) locations and executes the power-up procedure. The whole instrument is reinitialized - hardware, RAM, and NOVRAM.

NOTE: The unit is no longer in remote control mode after executing this command.

Modifying this command causes a test restart.

EXAMPLE:

> **FIRST P U** :reload NOVRAM with factory settings
:no longer in remote control

HEL

HEL

Display the T-BERD 224 Software Revision Level

HEL? :Displays the software revision level and option configuration

HEL displays the T-BERD 224's hardware and software revision levels and any options that are included in the instrument as well as any self-test errors, such as "NOVRAM LOST".

EXAMPLE:

> HEL? :display the hardware and software revision level

T-BERD 224, Software Version B, (c) TTC 6/30/90
DSU-DP Option installed
IEEE-488 Option installed
ZBTSI Option installed
>

On-Line Help Function

HELP !	:Display the list of all valid commands
HELP	:Displays an index to all help information
HELP <number>	:Displays help information on the page number specified (See the following list of help page numbers)
HELP <command-name>	:Displays the parameter syntax for <command name>

HELP provides access to the T-BERD 224's on-line help facility. **HELP** offers summary on-line help information. **HELP** or **HELP 1** provides an index to the various types of help information. **HELP !** lists all valid T-BERD 224 remote control commands. **HELP <number>** displays a specific page of help information. **HELP <command-name>** defines and displays the command syntax for any specified remote control command. The following conventions apply:

- (1) Command parameters are presented in a single column with the default value listed first (see Example 1).
- (2) Command and parameter summaries are preceded by three dashes (- - -) (See Example 2).
- (3) Command parameters are presented as upper case character strings with optional characters in lower case characters (see Example 3).

The following help commands are available to view specific groupings of remote commands.

HELP 1	:Displays an index to all help information
HELP 2	:Displays help information for special characters
HELP 3	:Displays help information for printer commands
HELP 4	:Displays help information for control commands
HELP 5	:Displays help information for auxiliary function commands

HELP

HELP

On-Line Help Function (Continued)

HELP 6 :Displays help information for remote only commands

HELP 7|8 :Displays help information for switches

EXAMPLE 1:

```
> HELP DISPLAY
  LOCAL
  REMOTE
>
```

EXAMPLE 2:

```
> HELP CLOCK
```

:these are the valid formats for the **CLOCK** command

```
[HH:MM:SS]
[HH-MM-SS]
[HH/MM/SS]
[HH;MM;SS]
[HH.MM.SS]
[HH,MM,SS]
```

```
-- -HH 0 TO 23 HOURS :lists the valid ranges
-- -MM 0 TO 59 MINUTES
-- -SS 0 to 59 SECONDS
```

```
>
```

EXAMPLE 3:

```
> HELP PRI EVE

ERRor SECond
OFF
TEST END
TIMed
```

```
>
```

SECTION 6

HIS RES

HIS RES

Reset Alarm History LED Indicators

HIS RES :Sets the alarm history LEDs off

HIS RES resets all alarm history LED indicators for both lines.

EXAMPLE:

> **HIS RES** :clear history LED indicators

>

HOL**HOL****Hold All Printer Outputs****HOL** :Places printer outputs into a buffer

HOL temporarily holds printer outputs (in the print buffer) until a **REL** command is specified. Note that while the **HOL** command is enabled, the prompt character changes from the standard ">" (or user-specified prompt) to a "+" to indicate that the printer output is being held. Printouts held include results printouts, control printouts, alarm messages, and status messages. However, responses to queries are returned as before.

See also: **REL****EXAMPLE:**

```
> HOL :hold all printouts for now ...
+CLOCK? :requests the clock time
  CLOCK 12:34:56
+DATE? :requests the calendar date
  DATE APR 14
+CONTROLS? :(note that nothing is printed)
+REL :start printing the controls print
>

> ... and the prompt is changed back to ">"
```

SECTION 6

INS

INS

Insert

INS? :Displays the status of the **INSERT** switch
INS [L1|L2|NON] :Select line for channel insertion

INS? requests the line on which T1 signal data and errors are inserted. **INS L1** selects LINE 1; **INS L2** selects LINE 2; **INS NON** selects neither line.

EXAMPLE:

> **INS?** :displays the current channel insert status
INSert L1
> **INS L2** :select LINE 2 channel insertion
>

L1 CHA

L1 CHA

LINE 1 Channel Selection

L1 CHA? :Display the selected channel
L1 CHA [nn|ALL|- -] :Select the channel for LINE 1

L1 CHA selects or returns LINE 1's channel to be monitored or tested. **L1 CHA nn** selects the channel number (where nn is the channel number 1-24), **L1 CHA ALL** selects all channels, and **L1 CHA - -** selects no channels for testing and analysis.

Modifying this command causes a test restart.

NOTE: Valid channel selections are determined by the current setup.

EXAMPLE:

> **L1 CHA?** :displays the current LINE 1 channel selection
L1 CHannel 10
> **L1 CHA - -** :sets the LINE 1 channel selection to none
>

SECTION 6

L1 LBO

L1 LBO

LINE 1 Line Build-Out

L1 LBO? :Displays the status of the line build-out for
LINE 1

L1 LBO [0|-7.5|-15] :Select line build-out setting

L1 LBO controls the current transmit output setting for LINE 1, allows the user to select emulation of three different cable losses for T1 rates. Selectable line build-out includes **0**, **-7.5**, and **-15**.

This command is identical to the AUX 05 LBO function.

EXAMPLE:

```
> L1 LBO? :display current line build-out status in dB
  L1 LBO 0 dB
> L1 LBO -15 :select -15 dB position
>
```

L1 REC INP

L1 REC INP

LINE 1 Receive Input Termination

L1 REC INP? :Display the status of the current receive input termination for LINE 1

L1 REC INP [BRI|TER|DSX] :Select the receive input termination setting for LINE 1

L1 REC INP selects input impedance and signal conditioning for the LINE 1 RECEIVE connector. **L1 REC INP BRI** (bridge) sets the LINE 1 RECEIVE connector to bridge; **L1 REC INP TER** (terminate) sets the LINE 1 RECEIVE connector to terminate; **L1 REC INP DSX** (DSX-monitor) sets the LINE 1 RECEIVE connector to DSX-monitor.

Modifying this command causes a test restart.

EXAMPLE:

> **L1 REC INP?** :display the current LINE 1 receive input termination status

L1 RECEive INPut TERminate

> **L1 REC INP BRI** :sets the LINE 1 RECEIVE connector to bridge input termination

>

SECTION 6

L1 REC SIG

L1 REC SIG

LINE 1 Receive Signal Status

L1 REC SIG? :Displays the status of the current received signaling bits for LINE 1

L1 REC SIG displays the logical state of the signaling bits received on the selected channel received on LINE 1. The signaling bits are returned in the format XXXX which corresponds to ABCD; where X = 1, the logic state is active (ON) and where X = 0, the logic state is inactive (OFF).

NOTE: For this response to be returned, the selected CHANNEL FORMAT must be set to VF or VF THRU. The number of signaling bits is determined by the current MODE setting. The ABCD signaling status LEDs correspond to the indicators located below the associated line.

EXAMPLE:

> **L1 REC SIG?** :displays the status of the current signaling bit for LINE 1

L1 RECEive SIGNAL 01 :displays the status of LINE 1 channel, where signaling bit A = 0 and B = 1

>

L2 CHA

L2 CHA

LINE 2 Channel Selection

L2 CHA? :Display the selected channel

L2 CHA [nn|ALL|- -] :Select the channel for line 2

L2 CHA selects or returns **LINE 2**'s channel to be monitored or tested. **L2 CHA nn** selects the channel number (where nn is the channel number 1-24), **L2 CHA ALL** selects all channels, and **L2 CHA - -** selects no channels for testing and analysis.

Modifying this command causes a test restart.

NOTE: Valid channel selections are determined by the current setup.

EXAMPLE:

> **L2 CHA?** :displays the current **LINE 2** channel status

L2 CHAnnel 10

> **L2 CHA - -** :sets the **LINE 2** channel status to none

>

SECTION 6

L2 LBO

L2 LBO

LINE 2 Line Build-Out

L2 LBO? :Displays the status of the line build-out for
LINE 2

L2 LBO [0|-7.5|-15] :Select line build-out setting

L2 LBO controls the current transmit output setting for LINE 2, allows the user to select emulation of three different cable losses for T1 rates. Selectable line build-out includes **0**, **-7.5**, and **-15**.

This command is identical to the AUX 05 LBO function.

EXAMPLE:

> **L2 LBO?** :display current line build-out status in dB

L2 LBO 0 dB

> **L2 LBO -15** :select -15 dB position

>

L2 REC INP**L2 REC INP**

LINE 2 Receive Input Termination

L2 REC INP? :Display the status of the current receive input termination for LINE 2

L2 REC INP [BRI|TER|DSX] :Select the receive input termination setting for LINE 2

L2 REC INP selects input impedance and signal conditioning. **L2 REC INP BRI** (bridge) sets the LINE 2 RECEIVE connector to bridge; **L2 REC INP TER** (terminate) sets the LINE 2 RECEIVE connector to terminate; **L2 REC INP DSX** (DSX-monitor) sets the LINE 2 RECEIVE connector to DSX-monitor.

Modifying this command causes a test restart.

EXAMPLE:

> **L2 REC INP?** :display the current LINE 2 receive input termination status

L2 REceive INPut TERminate

> **L2 REC INP BRI** :sets the LINE 2 RECEIVE connector to bridge input termination

>

SECTION 6**L2 REC SIG****L2 REC SIG****LINE 2 Receive Signal Status**

L2 REC SIG? :Displays the status of the current received signaling bit for LINE 2

L2 REC SIG displays the logical state of the signaling bits received on the selected channel received on LINE 2. The signaling bits are returned in the format XXXX which corresponds to ABCD; where X = 1, the logic state is active (ON) and where X = 0, the logic state is inactive (OFF).

NOTE: For this response to be returned, the selected CHANNEL FORMAT must be set to VF or VF THRU. The number of signaling bits is determined by the current MODE setting. The ABCD signaling status LEDs correspond to the indicators located below the associated line.

EXAMPLE:

> **L2 REC SIG?** :displays the status of the current signaling bit for LINE 2

L2 RECEive SIGNAL 01 :displays the status of LINE 2 channel, where signaling bit A = 0 and B = 1

>

LED**LED**

LED Status

LED?:Displays the state of the LINE 1 and
LINE 2 alarm and status LEDs

LED displays the state of the T-BERD 224's alarm and status LED indicators. When specified, this command displays the LED indicators as they appear on the front panel.

EXAMPLE:

> LED?

LINE 1 LEDS	HIST	CURR
SIGNAL	:	ON
FRAME SYNC	:	ON
PATTERN SYNC	:	
B8ZS	:	
EXCESS ZEROS	:ON	
YELLOW ALARM	:	
AI5	:	

LINE 2 LEDS	HIST	CURR
SIGNAL	:	ON
FRAME SYNC	:	ON
PATTERN SYNC	:	
B8ZS	:	
EXCESS ZEROS	:	
YELLOW ALARM	:ON	
AI5	:	

>

SECTION 6**LOCA****LOCA****Return the T-BERD 224 to Local Mode**

LOCA :Enter Local mode
/ :Alternate form of the **LOCA** command

LOCA returns the T-BERD 224 to Local mode from Remote Control. In Local mode, all of the T-BERD 224 front-panel switches are active.

The T-BERD 224 remains in Local mode until the user specifies any valid remote control command from the remote control unit.

See also: **DIS**, **REM**, **TER**, and **COM**

EXAMPLE:

```
> LOCA :enter Local (front panel) mode ...  
(TERMINAL) : ... then return to Remote Control mode  
Terminal mode initiated.....  
Type "HELP" followed by a <RETURN>  
for help. :message for terminal mode  
>/ :quickly return to Local mode  
>
```

MES

MES

Enable or Disable Error Message Printing

MES :Display current status of error message printing

MES [ON|OFF] :Enable or disable error message printing

MES controls the printing of error messages at your remote control unit. **MES ON** enables the printing of error messages when appropriate conditions exist; **MES OFF** disables the printing of error messages under such conditions.

See also: **ERR NUM**

EXAMPLE:

> **MES?** :display current status
MESSAGES OFF
> **MES ON** :enable error message printing
>

SECTION 6

MOD

MOD

Transmit and Receive Mode

MOD? :Display current mode
MOD (mode) :Select a mode

MOD sets or returns the current transmit and receive line rate and data format. The selected **(mode)** can be one of the following.

T1D1d	:T1 rate with D1D framing
T1D2	:T1 rate with D2 framing
T1D4	:T1 rate with D4 framing
T1ESF	:T1 rate with ESF framing
T1ESFZ	:T1 rate with ESFz framing and ZBTSTI (optional)
T1SLC	:T1 rate with SLC-96 framing
T1TLB	:T1 rate in Test Loopback mode
T1LLB	:T1 rate in Line Loopback mode
AUTO	:Automatic configuration mode

This command is identical in function to the **MODE** switch on the T-BERD 224's front-panel.

Modifying this command causes a test restart and may change the current setup.

EXAMPLE:

```
> MOD? :display status of mode
  MODe T1SLC
> MOD T1D4 :set mode to T1 rate with D4 framing
  WARNING: New Setup:
  MODe T1D4
  CHAnnel FORmat DS0
  SOURce 1 BYTe
  SOURce 2 10101001

>
```

PRI

PRI

Initiate Printout

PRI [CON|RES|valid result name] :Initiate controls or results printout

PRI enables you to initiate a result or controls print. The **PRI CON** and **PRI RES** commands generate controls and results printouts respectively.

Valid result names are as follows:

ALA SEC1	ALA SEC2	BPV RT1	BPV RT2	BPV1
BPV2	BPV SEC1	BPV SEC2	CRC ERR1	CRC ERR2
CRC ERT1	CRC ERT2	CRC E S1	CRC E S2	CRC SES1
CRC SES2	DAT	ELA TIM1	ELA TIM2	FRM ERR1
FRM ERR2	FRM ERT1	FRM ERT2	FRM E S1	FRM E S2
FRM LOS1	FRM LOS2	FRM L S1	FRM L S2	FRM SES1
FRM SES2	RCV BYT1	RCV BYT2	RCV FRE1	RCV FRE2
RCV DBM1	RCV DBM2	RCV DBX1	RCV DBX2	RCV VPP1
RCV VPP2	SIG L S1	SIG L S2	SLI SEC1	SLI SEC2
TES END	TES LEN	TIM	TIM SLI1	TIM SLI2
TRA D4	TRA ESF1	TRA ESF2	VF FRE1	VF FRE2
VF LEV1	VF LEV2			

See also: **CON** and **RESULTS**

EXAMPLE:

```

> PRI RES                               :generate results print
.                                       :results print follows
.
> PRI CON                               :generate controls print
.                                       :controls print follows
.
> PRI BPV1?                             :generate the BPVs for LINE 1
  BPV1 0                               :prints total number of BPVs for
                                         LINE 1

>

```

SECTION 6

PRI EVE

PRI EVE

Print Event

PRI EVE? :Display the print event setting

PRI EVE (event) :Select print event

PRI EVE allows you to determine when (if at all) the T-BERD 224 generates automatic test results prints and alarm/status messages. The **(event)** choices are as follows:

OFF :Halt automatic results prints
TES END :Print at end of timed test
ERR SEC :Print on the occurrence of BPV, frame error or CRC error
TIM H:MM:SS :Print results at the time interval specified

Any setting other than **PRI EVE OFF** enables automatic results printouts when one or more alarm conditions change. When specifying **TIM H:MM:SS**, the symbol ":" may be replaced by a dash (-), comma (,), period (.), or slash (/). The valid range for H (hours) is 0-5. The valid range for MM (minutes) is 0-59. The valid range for the optional second SS is 0-45 in 15 second increments.

See also: **TIM PRI EVE**

EXAMPLE:

```
> PRI EVE? :display status of print event
  PRInt EVEnt OFF
> PRI EVE TES END :print results at end of timed test
>
```

PRI TER**PRI TER****Printer Terminator**

PRI TER? :Display the current printer line terminator
PRI TER [CR|CRLF|LF] :Set the printer line terminator

PRI TER controls the line termination for a printer or remote control device. When you specify **PRI TER CR**, a carriage return is transmitted at the end of each printed line; when you specify **PRI TER CRLF**, each printed line is followed by a carriage return and linefeed; when you specify **PRI TER LF**, each printed line is followed by a line feed.

This command is identical to the AUX 08 RS 232 function.

EXAMPLE:

> **PRI TER?** :display the current line terminator
 PRInt TERm CRLF
 > **PRI TER CR** :select carriage return as line terminator
 >

SECTION 6**PRO****PRO****Remote Control Prompt**

PRO? :Display status of prompt
PRO [ON|OFF] :Turn prompt on or off
PRO STRING (prompt-string) :Define a prompt

PRO controls the prompt symbol at the remote control unit. **PRO ON** enables the display of a ">" as the prompt symbol when the T-BERD 224 is ready to receive a command. **PRO OFF** turns off the prompt symbol. **PRO STRING** allows the user to define a prompt symbol (or prompt string) of 100 characters. This custom prompt is not stored in NOVRAM.

Note that the T-BERD 224 changes any current prompt symbol to "+" when the **HOL** command is specified.

EXAMPLE:

```
> PRO? :display prompt status
  PROMPT ON
> PRO STRING = :define "=" as prompt symbol
=PRO OFF :turn off the "=" prompt
CLOCK? :display the time (no prompt)
  CLOCK 10:33:04
PROMPT ON :turn on the "=" prompt
=
```

REL**REL**

Printer Hold Release

REL :Releases printouts held in the printer buffer

REL releases all output in the print buffer from HOLD status. When the release command is specified, the prompt character changes from the “+” to the standard “>” (or user-specified prompt) to indicate that printer output is no longer held.

See also: **HOLD**

EXAMPLE:

```

> HOLD                :hold all printouts for now ...
+CLOCK?              :requests the clock time
  CLOCK 12:34:56
+DATE?               :requests the calendar date
  DATE APR 14
+CONTROLS            :(note that nothing is printed)
+REL                 :start printing the controls print
>                    :... and the prompt is changed back to “>”

```

SECTION 6

REM

REM

Remote Control Entry

REM :Sets the T-BERD 224 to Remote Control mode

REM places the T-BERD 224 in Remote Control mode. In Remote Control mode, all front-panel switches are inactive (with the exception of the **RESULTS I** and **RESULTS II Category** and Results switches).

Unlike the **TER** command, the **REM** command does not turn prompts, echo, and messages on.

See also: **LOCA**, **TER**, **COM**, and **DIS**

EXAMPLE:

REM :enter Remote Control mode from Local mode
:the prompt, echo, and messages must be enabled if they are desired to be displayed

RES 1 and 2

RES 1 and 2

Result Display Control

RES 1 (result name)	:Display (result) in Result I display
RES 2 (result name)	:Display (result) in Result II display
RES 1?	:Return the value displayed in the Result I display
RES 2?	:Return the value displayed in the Result II display

The **RES 1** and **RES 2** commands control the displayed results on the front panel of the T-BERD 224. Unlike the **PRINT** command, the front panel is updated to reflect the result specified; the value of the specified result is not displayed at the remote control unit. Valid (**result name**) selections are:

ALA SEC1	ALA SEC2	BPV RT1
BPV RT2	BPV1	BPV2
BPV SEC1	BPV SEC2	CRC ERR1
CRC ERR2	CRC ERT1	CRC ERT2
CRC E S1	CRC E S2	CRC SES1
CRC SES2	DAT	ELA TIM1
ELA TIM2	FRM ERR1	FRM ERR2
FRM ERT1	FRM ERT2	FRM E S1
FRM E S2	FRM LOS1	FRM LOS2
FRM L S1	FRM L S2	FRM SES1
FRM SES2	RCV BYT1	RCV BYT2
RCV FRE1	RCV FRE2	RCV LVL1
RCV LVL2	RCV LVL1	RCV LVL2
RCV LVL1	RCV LVL2	SIG L S1
SIG L S2	SLI SEC1	SLI SEC2
TES END	TES LEN	TIM
TIM SLI1	TIM SLI2	TRA D4
TRA ESF1	TRA ESF2	VF FRE1
VF FRE2	VF LEV1	VF LEV2

See also: **PRI**

SECTION 6

RES 1 and 2

RES 1 and 2

Result Display Control (Continued)

EXAMPLE:

> RES 1 DAT	:display date in Results I display
> RES 2 FRM L S1	:display LINE 1 frame loss seconds in Results II display
> RES 1?	:print the result that is currently in Results I display
DAT MAY 20	
>	

RESTART

RESTART

Test Restart

RESTART

:Clears accumulated results values and re-starts the test

RESTART restarts the T-BERD 224 test by clearing all results to zero.

EXAMPLE:

> **RESTART**

:restart test

>

SECTION 6

RESULTS

RESULTS

Results Printout

RESULTS :Displays the results values

RESULTS causes a printout of the current result values.

EXAMPLE:

> **RESULTS** displays the results values

.
. .
. .
>

RS232

RS232

RS-232 Parameters

RS232? :Displays the current RS-232 parameters

RS-232 is used to obtain the T-BERD 224's current RS-232 parameters: BAUD, DATA BITS, and PARITY. **RS232** is an "inquire only" command; you cannot change the parameters using this command.

NOTE: **RS232?** returns the status of the AUX 08 RS232 function.

EXAMPLE:

> **RS232?** :displays the current RS232 parameters

RS232 BAUD 9600
RS232 DATA BITS 8
RS232 PARITY NONE

> **RS232 BAUD?** :displays the current RS232 baud rate

RS232 BAUD 9600

>

SECTION 6

SET

SET

Setup Summary

SET? :Displays the current T-BERD 224 test setup for: **MODE**, **CHANNEL FORMAT**, and both **SCI** and **II** switches

SET displays the current T-BERD 224 test setup.

EXAMPLE:

> **SET?** :display current T-BERD 224 setup
MODE T1D4
CHAnnel FORmat DS0
SOUrce 1 BYTe
SOUrce 2 10101001

> **HELP SET** :list all selections for each of the four switches (**MODE**, **CHANNEL FORMAT**, **SCI**, and **SCII**)

>

SIG INS

SIG INS

Channel Signaling Bit Insert

SIG INS A?	:Displays the logical state of inserted signaling bit A
SIG INS B?	:Displays the logical state of inserted signaling bit B
SIG INS C?	:Displays the logical state of inserted signaling bit C
SIG INS D?	:Displays the logical state of inserted signaling bit D
SIG INS ALL?	:Displays the logical state of the signaling bits
SIG INS A [OFF ON]	:Sets the logical state of the inserted signaling bit A
SIG INS B [OFF ON]	:Sets the logical state of the inserted signaling bit B
SIG INS C [OFF ON]	:Sets the logical state of the inserted signaling bit C
SIG INS D [OFF ON]	:Sets the logical state of the inserted signaling bit D
SIG INS ALL [XX XXXX]	:Sets the logical state of the signaling bits

Sets or returns the logic state of signaling bit A to be transmitted for a selected channel. A logic 1 (ON) or 0 (OFF) may be transmitted for the signaling bit. Signaling bits C and D are only set when the **MODE** switch is set to ESF or ESFz*. When ALL is selected, all signaling bits (2 or 4) must be inserted for the selected MODE.

NOTE: The **INSERT** switch must not be set to NONE and the insert line's channel number must not be — (none). CHANNEL FORMAT must be set to VF and for signaling bits C and D, the **MODE** switch must be set to ESF or ESFz (optional).

*Requires ZBTSI Framing Option.

SECTION 6

SIG INS

SIG INS

Channel Signaling Bit Insert (Continued)

EXAMPLE 1:

- > **SIG INS A ON** :sets the current logical state of the A signaling bit to a logic 1 (ON)
- > **SIG INS A?** :displays the current logical state of the A signaling bit

SIGnal INSert ON

>

Bits A and B are inserted for:

D1D
D2
D4
SLC-96

Bits A, B, C, and D are inserted for:

ESF
ESFz

EXAMPLE 2:

- > **SIG INS ALL?** :displays the current logical state of the signaling bit
- SIGnal INSert ALL 10
- > **SIG INS ALL 11** :sets the signaling bit A to a logical 1 and signaling bit B to a logical 1

>

SOU 1

SOU 1

Source Configuration I

SOU 1? :Displays the current selection for the **SCI** switch

SOU 1 (parameter) :Selects the setting for the **SCI** switch

SOU 1 selects or returns the drop and insert source which is to be used when analyzing the selected channel(s).

The following parameters are available:

1004	:1004 Hz tone
VF INT	:Voice Frequency Interface
BYT [xxxxxxxx]	:Byte
DS0 INT	:DS0 Interface
DRO CHA	:Drop Channel

Modifying this command causes a test restart and may change the current setup.

EXAMPLE:

> SOU 1? :displays current SOURCE CONFIGURATION I selection

SOURce 1 1004

> SOU 1 BYT 10101010 :select the byte encoder as the new source configuration and set the desired byte contents

WARNING: New Setup:

MODE T1D4

CHAnnel FORMat DS0

SOURce 1 BYTe

SOURce 2 10101010

>

SECTION 6**SOU 2****SOU 2****Source Configuration II**

- SOU 2?** :Displays the current status for the **SCII** switch selection
- SOU 2 (parameter)** :Selects the setting for the **SCII** switch

SOU 2 augments the **SCI** switch selection. Selects or returns the drop and insert source which is to be used when analyzing the selected channel(s).

The following parameters are available:

- [XXXXXXXX] :sets the programmable bit sequence (where x can be a 1 or a 0) of the **BYTE** setting of **SOURCE CONFIGURATION I**

Modifying this command causes a test restart.

EXAMPLE:

- > **SOU 2?** :display the current **SOURCE CONFIGURATION II** selection
- SOURce 2 10101001
- > **SOU 2 10110101** :change the byte definition to 10110101
- WARNING: New Setup:
- MODe T1D4
- CHAnnel FORmat DS0
- SOURce 1 BYTe
- SOURce 2 10101010
- >

TER

TER

Configure the T-BERD 224 for Remote Control Operation

TER :Selects the Terminal control mode
 . (period) :Alternate form of the **TER** command

TER configures the T-BERD 224 for remote control operation by automatically setting the following:

ECHO ON :turn echo on
PROMPT ON :turn command prompts on
TERM CRLF :line terminator of carriage return and line feed
MESSAGES ON :causes error messages to be printed

This command is typically used as a log-in sequence when entering Remote Control mode from a dumb terminal. Typing a period (.), followed by a carriage return, places the T-BERD 224 in Terminal mode and provides a default prompt (>) printed on the screen.

When the **TER** command is specified, all front-panel switches (except the **RESULT** switches) are inactive.

See also: **LOCA**, **REM**, **COM**, and **DIS**

EXAMPLE:

(.) :places the T-BERD 224 in Remote Control mode and locks out the front panel switches. The T-BERD 224 front panel flashes the message "UNDER REMOTE CONTROL" in the left display window. The message Terminal mode initiated.

Type "HELP" followed by a <RETURN> for help.

> :the T-BERD 224 responds with a prompt and is now in Terminal mode.

TES**TES****Test Results Accumulation**

TES? :Display the current test type
TES [TIM|CON] :Set the test type
TES TIM [HHH:MM:SS] :Set the test to timed and specifies the test length in hours, minutes, and seconds

TES enables you to specify the duration of a test. When you specify **TES TIM**, the T-BERD 224 conducts a timed test of the duration specified in the AUX 03 TES LEN function. When you specify **TES CON**, the T-BERD 224 accumulates test results continuously.

NOTE: Changing from continuous to timed causes a test restart.

See also: **TES LEN**

EXAMPLE:

> **TES?** :display the current test type
TESt CONTinuous
> **TES TIM** :select a timed test
>

TES LEN

TES LEN

Test Length

TES LEN? :Display the current test length setting**TES LEN HHH:MM:SS** :Set new test length

TES LEN sets the length of a timed test. The parameter **HHH:MM:SS** is given in hours, minutes, and seconds, respectively; each can be specified separately (HHH, MM, or SS). When setting a new test length, the symbol ":" may be replaced by a dash (-), comma (,), period (.), semicolon (;), or slash (/). The valid ranges for each time value are:

HHH:	0-200 hours
MM:	0-59 minutes
SS:	0-45 seconds

This command is identical to the AUX 03 TES LEN function.

NOTE: The test length may also be set using the TES TIM command.

See also: **TES**

EXAMPLE:

```
> TES LEN? :display the current test length setting
TEST LENGTH 12:35:00 :current test length is 12 hours, 35 minutes,
and 00 seconds
> TES LEN ; 6 ; :test length now is 6 minutes
>
```

SECTION 6**TIM PRI EVE****TIM PRI EVE**

Time Print Event

TIM PRI EVE? :Display the current time interval for results printouts

TIM PRI EVE H:MM:SS :Set the time interval for results printouts

TIM PRI EVE sets the length of time interval for results printouts. The parameter **H:MM:SS** is given in hours, minutes, and seconds, respectively; each can be specified separately (H, MM, or SS). When setting a new test length, the symbol ":" may be replaced by a dash (-), comma (,), period (.), semicolon (;), or slash (/). The valid ranges for each time value are:

H:	0-5 hours
MM:	0-59 minutes
SS:	0-45 seconds (in 15 second intervals)

This command is identical to AUX 02 (TIM PRI).

NOTE: The print event time may also be set using the **PRI EVE TIM** command. The print event must be set to TIMED to have timed printouts generated.

See also: **PRI EVE**

EXAMPLE:

> **TIM PRI EVE?** :display the current time interval setting
TIMed PRInt EVEnt 4:30:00 :current print event is 4 hours, 35 minutes, and 0 seconds

> **TIM PRI EVE 3:30:00** :print event now is 3 hours and 30 minutes

>

VOL

VOL

Loudspeaker Control

VOL? :Displays the current status of the T-BERD 224 **VOLUME** switch

VOL [ON|OFF] :Turns the speaker ON or OFF

VOL enables or disables the audio speaker of the T-BERD 224 internal loud speaker. When set to **ON**, the actual audio level is controlled by the position of the front panel **VOLUME** slide control and the dropped channel(s) contents are output to the side panel loudspeaker. **VOL OFF** turns off the loudspeaker.

NOTE: Each time the unit power is turned off and then on again, the status of this control is always set to ON.

EXAMPLE:

> **VOL?** :displays the current volume status

VOLUME OFF

> **VOL ON** :enables the speaker volume

>

SPECIFICATIONS

7.1 INTRODUCTION

This section contains specifications for the T-BERD 224 PCM Analyzer.

7.2 GENERAL SPECIFICATIONS

7.2.1 Physical

- Dimensions: 6.5" H x 14.0" W x 11.0" D (16.51 cm x 35.56 cm x 27.94 cm).
- Weight: 16.2 lbs. (7.3 kgs.).

7.2.2 Environmental Specifications

- Operating temperature range: 32°F to 113°F (0°C to 45°C).
- Storage temperature range: -40°F to 158°F (-40°C to 70°C).
- Operating Humidity: 90% maximum, noncondensing.
- Storage Humidity: 5% to 95% noncondensing.
- Power: 115/230 VAC \pm 10%.
- Fuse: 1A, 250 V, Slo-Blo; (Littlefuse #218001, or equivalent).
- Shock and Vibration: Meets IEEE Standard 743 specifications.

SECTION 7

- **Electrostatic Discharge Susceptibility:** Withstands at least 10 consecutive direct static discharges of 0.01 joule and 15 kV to any operator-accessible switch or cable without malfunction. In addition, no malfunction occurs when the device is operated 1 meter distant from any object which receives at least 10 consecutive, direct static discharges of the same severity.
- **Electromagnetic Interference Susceptibility:** No malfunction occurs when this device is operated near any source of EMI, including telemetry and radio communication equipment where the field strength and/or proximity to such sources is a typical operating environment for this type of device.

7.3 INPUT SPECIFICATIONS

- **Input Connectors:** 2 WECO 310 jacks.
2 bantam jacks.
- **Input Frequency:** 1,544,000 Hz \pm 5000 Hz.
- **Input Impedance:** BRIDGE — 1000 ohms or greater.
TERM — 100 ohms \pm 5%.
DSX-MON — 100 ohms \pm 5%.
- **Input Signal Level:** BRIDGE — +6 dBdsx to -35 dBdsx.
ALBO compensates for cable loss characteristics.

TERM — +6 dBdsx to -35 dBdsx.
ALBO compensates for cable loss characteristics.

DSX-MON — +6 dBdsx to -24 dBdsx.
No ALBO provided; resistive loss compensation only.

7.4 OUTPUT SPECIFICATIONS

- Output Connectors: 2 WECO 310 jacks.
2 bantam jacks.
- Output Line Build-out: Selectable line build-out of 0 dB, 7.5 dB, or 15 dB is provided.
- Output Line Build-out Tolerance: ± 1 dB at 772 kHz.
- Pulse Shape: With the output terminated into a 100-ohm resistive load and 0 dB line build-out selected, the T-BERD 224 meets the pulse shape specifications given in CCITT Recommendation G.703; Bell Publications CB113, CB119, and CB143; and AT&T PUB62508; and AT&T PUB62411.
- Internal Oscillator Accuracy: 5 ppm.
- Line Codes: Bipolar (pseudoternary). Switch-selectable AMI or B8ZS.

7.5 MEASUREMENTS

7.5.1 T1 Frequency

- Accuracy: ± 5 ppm.
- Resolution: 1 Hz.
- T1 Range: 1,544,000 Hz, ± 5000 Hz.

SECTION 7

- Input Configuration: AC-coupled differential input.
Inner conductor is signal.
- Signal Level: High, greater than 2 V.
Low, less than 0.5 V.
- Clock Voltage Level: 2 V p-p, minimum.
20 V p-p, maximum.
- Clock Frequency: 1.544 MHz \pm 5000 Hz.

7.6.2 RS-232 Printer/Remote Connector

- Connector Type: 25-pin, D-type.
- Connector Configuration: DCE.
- Connector Pin Configuration: See Table 7-1.
- Character Format: 7 or 8 data bits (ASCII coding).
- Parity: Odd, even, or none.
- Stop Bits: 2 transmitted. Accepts 1 or more received stop bits.
- Baud Rates: 300, 1200, 2400, 4800 or 9600.
- Terminator: CR, LF, or CRLF.
- Print Width: 80-column.

Table 7-1
RS-232 Pin Configuration

Pin No.	Signal Description	Function
1	Protective Ground	Connected to chassis ground.
2	Transmit Data (TXD)	The T-BERD 224 receives data on this lead.
3	Receive Data (RCVData)	The T-BERD 224 transmits data on this lead.
4	Request to Send (RTS)	This lead is ignored by the T-BERD 224.
5	Clear to Send (CTS)	The T-BERD 224 drives this lead to the ON (HIGH) state when the unit is ready to accept another character from the transmitting device. Fast devices, like computers, need to monitor this line before transmitting additional data.
6	Data Set Ready (DSR)	The T-BERD 224 drives this line to the ON (HIGH) state whenever power is applied to it.
7	Signal Ground	Connected to signal ground.
8	Receive Line Signal Detect (RLSD)	The T-BERD 224 drives this line to the ON (HIGH) state whenever power is applied to it.
9	Pos DC Test Voltage	This lead provides +12 Vdc (RS-232 ON) for use in strapping signaling leads ON.
10	Neg. DC Test Voltage	This lead provides -12 Vdc (RS-232 OFF) for use in strapping signaling leads OFF.

**Table 7-1
RS-232 Pin Configuration (Continued)**

Pin No.	Signal Description	Function
12	Sec RLSD	The T-BERD 224 drives this lead ON (HIGH) whenever data in its FIFO is ready to print.
20	Data Terminal Ready (DTR)	When this lead is driven ON (HIGH) by the receiving device, the T-BERD 224 transmits data.

7.6.3 Test Points

Table 7-2 contains descriptions of the T-BERD 224's test points which are available on the side panel's 37-pin, D-type connector. Signals present at these test points are TTL levels.

**Table 7-2
T-BERD 224 Test Points**

Pin No.	Input/Output	Pin Name	Description
1	O	Line 1 Signaling Bit D	Active high
2	O	Line 1 Signaling Bit B	Active high
3	O	Line 1 Signaling Bit C	Active high
4	O	Line 1 Signaling Bit A	Active high
5	O	Line 1 BPV	One-half bit wide, active low
6	I	Insert Signaling Bit D	Active high
7	I	Insert Signaling Bit C	Active high
8	I	Insert Signaling Bit B	Active high

Table 7-2
T-BERD 224 Test Points (Continued)

Pin No.	Input/Output	Pin Name	Description
9	I	Insert Signaling Bit A	Active high, active low
10	I	Enable Insert Signaling Bits	Enable the external signaling insert from test points
11	O	Line 2 BPV	One bit wide, active low
12	N/C		
13	O	Line 1 AIS	Active low
14	O	Line 1 Yellow Alarm	Active high
15	O	Line 1 Frame Sync	Active high
16	O	Line 1 CRC Error	Active high for 7 ± 1 microseconds for each CRC error
17-19	N/C		
20	O	Line 2 Signaling Bit D	Active high
21	O	Line 2 Signaling Bit C	Active high
22	O	Line 2 Signaling Bit B	Active high
23	O	Line 2 Signaling Bit A	Active high
24-30	N/C		
31	O	Line 2 AIS	Active low
32	O	Line 2 Yellow Alarm	Active high
33	O	Line 2 Frame Sync	Active high
34	O	Line 2 CRC Error	Active high for 7 ± 1 microseconds for each CRC error
35	N/C		
36	N/C		
37		Signal Ground	

SECTION 7

- Signaling Inputs: Input Voltage Range — -0.5 V to $+25\text{ V}$.

 Logic 0 (On Hook) Input — Open circuit or $+2.5\text{ V}$ to $+25\text{ V}$.

 Logic 1 (Off Hook) Input — Closure to ground or -0.5 V to $+1.0\text{ V}$.

 Input Current — -1.5 microamps, maximum at 0 V . $+1.0$ microamps, maximum at $+3\text{V}$.
- Signaling Outputs: Output Voltage Range — 0.0 V to $+5\text{ V}$.

 Logic 0 (On Hook) Output — $+1.1\text{ V}$, maximum for 0 to 100 mA sink current. $+1.6\text{ V}$, maximum for 0 to 300 mA sink current.

 Logic 1 (Off Hook) Output — $+3.0\text{ V}$, minimum for 0 to 350 microamps source current. $+4.0\text{ V}$, minimum for 0 to 150 microamps source current.

7.6.4 VF 2-Wire Interface

- Connectors: 2 turrets.
- Impedance: 600 ohms.
- Loop Current: 25 mA, typical.
- Return Loss at
 1 kHz: Greater than 20 dB.

7.6.5 VF 4-Wire Interface

- VF Output: Connector — WECO 310 jack.

 Driver — 600 ohms with a minimum 28 dB return loss from 300 Hz to 3400 Hz.

Frequency Response — ± 0.25 dB (300 Hz to 3000 Hz). +0.25 dB to -1.5 dB (3000 Hz to 3400 Hz).

Tracking Distortion — Relative to 1004 Hz, -10 dBm0. +0.3 dB (+3 dBm0 to -40 dBm0). ± 0.6 dB (-40 dBm0 to -50 dBm0). +1.6 dB (-50 dBm0 to -55 dBm0).

Transmission Level Points — 0 dBm0 = 0 dBm.

- VF Input: Connector — WECO 310 jack.

Receiver — 600 ohms with a minimum 28 dB return loss from 300 Hz to 3400 Hz.

Frequency Response — ± 0.25 dB (300 Hz to 3000 Hz). +0.25 dB to -1.5 dB (3000 Hz to 3400 Hz).

Tracking Distortion — Relative to 1004 Hz, -10 dBm0. ± 0.3 dB (+3 dBm0 to -40 dBm0). ± 0.6 dB (-40 dBm0 to -50 dBm0). ± 1.6 dB (-50 dBm0 to -55 dBm0).

Transmission Level Points — 0 dBm0 = 0 dBm.

Clipping Point — +3 dBm0, typical.

Signal to Distortion Ratio — 33 dB, minimum (0 to -30 dBm0). Measured with C-message and with C-message with notch filter.

Idle Channel Noise — 18 dBm0, maximum.

7.6.6 DS0 Bipolar Bantam Interface

- Bipolar Input: Connector — Bantam jack.
Impedance — 135 ohms $\pm 10\%$.

Operating Signal Level — 3.0 V to 5.0 V peak.

Cable Length — 1500 feet (457 meters) of 24-gauge, maximum.

- Bipolar Output:

Data Rate — 64 kb/s.

Connector — Bantam jack.

Test Load Impedance — 135 ohms, resistive.

Pulse Amplitude — 4.0 V \pm 0.5 V with a maximum imbalance of 0.25 V.

“Zero” Output Level — 0.7 V, maximum.

Half-Amplitude Pulse Width — 15.6 microseconds \pm 0.5 microseconds with a minimum imbalance of 0.7 microseconds.

Rise and Fall Time — 0.5 microseconds, maximum.

Data Format — AMI and NRZ.

- Tx Clocks:

Pin 1 — +5 V at 100 mA, maximum.

Pin 2 — Ground.

Pin 3 — Tx (Insert) Bit Clock (TTL level into 50 ohms).

Pin 4 — Tx (Insert) Byte Clock (TTL level into 50 ohms).

Pin 5 — Ground.

Pin 6 — Tx (Insert) Byte Clock + (differential).

Pin 7 — Tx (Insert) Byte Clock - (differential).

Pin 8 — Tx (Insert) Bit Clock + (differential).

Pin 9 — Tx (Insert) Bit Clock - (differential).

- Rx Clocks:

Pin 1 — +5 V at 100 mA, maximum.

Pin 2 — Ground.

Pin 3 — Rx (Drop) Bit Clock (TTL level into 50 ohms).

Pin 4 — Rx (Drop) Byte Clock (TTL level into 50 ohms).

Pin 6 — Rx (Drop) Byte Clock + (differential).

Pin 7 — Rx (Drop) Byte Clock - (differential).

Pin 8 — Rx (Drop) Bit Clock + (differential).

Pin 9 — Rx (Drop) Bit Clock - (differential).

7.7 FRONT PANEL

7.7.1 Switches

- Modes: T1-D1D, T1-D2, T1-D4, T1-ESF, T1-ESFz*, T1-SLC96, T1 LLB, T1 TLB, AUTO.
- Channel Format: VF, VF THRU, DS0.
- Source Configuration I: 1004 Hz, VF INTF, DROP CHAN, BYTE, DS0 INTF.
- Source Configuration II: XXXXXXXX (where X = 1 or 0).
- Results: SUMMARY — BPVs, frame errors, CRC errors, frame losses, receive frequency, timing slips, power loss. (See Table 2-2 for non-zero and out-of-specification display results.)

BPV & FRAME — BPVs, BPV seconds, BPV rate, frame errored seconds, frame severely errored seconds, frame errors, frame error rate, CRC errors, CRC errored seconds, frame losses, frame loss seconds, CRC severely errored seconds, CRC error rate.

SIGNAL — receive frequency, receive level (dBdsx), receive level (dBm), receive level (Vp-p), timing slips, slip analysis seconds, traffic results.

TIME — signal loss seconds, alarmed seconds, test length, elapsed time, test ends, clock time, calendar date.

CHANNEL — received byte, VF frequency, VF level.

* Requires ZBTSI Framing Option

SECTION 7

- Transmit Code: AMI, B8ZS.
- Test Length: TIMED, CONT. (continuous).
- Timed Test Length: 15 seconds minimum, to 200 hours, 59 minutes, and 45 seconds, maximum.
- Print Event: TEST END, ERR SEC (errored second), TIMED, OFF.
- Channel: 1 to 24, ALL, — (none).
- Drop: LINE 1, BOTH, LINE 2.
- Insert: LINE 1, NONE, LINE 2.
- Transmit Output Level: 0 dB, -7.5 dB, -15 dB.
- Receive Input Termination: BRIDGE, TERM, DSX-MON.
- Signaling Insert: A, B, C, D.
- Error Insert: BPV — Inserts a bipolar violation on any transmitted bit that has a value of 1.

Frame — Inserts logic errors only on the transmitted framed synchronization bits (the Ft bits in D1D, D2, D4, and SLC framing and the frame pattern sequence bits in ESF and ESFz* framing).

Yellow alarm — Transmits a continuous Yellow Alarm. In D1D, D2, D4, and SLC framing, bit 2 of every DS0 channel is set to 0. In ESF and ESFz*, a repetitive pattern of eight 1's followed by eight 0's (1111111100000000) is generated in the data link.

*Requires ZBTSI Framing Option.

7.7.2 Indicators

- **Local Status:** Line 1 — Signal, Signal loss History, Frame Sync, Frame Sync loss History, B8ZS, B8ZS History, Excess Zeros, Excess Zeros History, Yellow Alarm, Yellow Alarm History, AIS, AIS History.

Line 2 — Signal, Signal loss History, Frame Sync, Frame Sync loss History, B8ZS, B8ZS History, Excess Zeros, Excess Zeros History, Yellow Alarm, Yellow Alarm History, AIS, AIS History.

7.7.3 Status and Alarm Criteria

- **SIGNAL:** The green status LED illuminates when a valid T1 signal is detected. The LED for the corresponding line (LINE 1 or LINE 2) indicates at which input the signal is detected.

The red history LED illuminates when no signal is detected for a period of 150 ms at the respective line input connector.

- **FRAME SYNC:** The green status LED illuminates when synchronization is achieved for the selected framing pattern within the received T1 data stream. The LED for the corresponding line illuminates to indicate at which input the signal is detected.

The red history LED illuminates upon frame sync loss for: D1D, D2, and D4 is 2 out of 4 frame bits in error; SLC-96 is 2 out of 4 F_1 bits in error; and ESF and ESFz* is 2 out of 4 frame bits in error.

Frame sync is declared for: D1D, D2, D4, and SLC-96 when synchronized to the F_1 and F_5 bits; and ESF and ESFz* when synchronized to the frame pattern sequence bits and at least one valid CRC-6 is received.

*Requires ZBTSI Framing Option.

SECTION 7

- **B8ZS:** The green status LED illuminates when B8ZS clear-channel codes are detected in the received T1 signal. The LED for the corresponding line illuminates to indicate at which input the coding is detected.

The red history LED illuminates when the B8ZS code is not detected for 150 ms.
- **EXCESS ZEROS:** The red status LED illuminates when 16 or more consecutive zeros are detected. The LED for the corresponding line illuminates to indicate at which input the excess zeros are detected.

The red history LED illuminates when excess zeros are no longer detected at the corresponding input.
- **YELLOW ALARM:** The red status LED illuminates when yellow alarm signals are detected. The LED for the corresponding line illuminates to indicate at which input the yellow alarm is detected. In D1D, D2, D4, and SLC-96, a yellow alarm is declared when bit 2 set to "0" for 255 consecutive DS0 channels. In ESF and ESFz*, a yellow alarm is declared when 256 bits \pm 16 bits of a repetitive FF00 pattern in the data link.

The red history LED is illuminated when yellow alarm is no longer detected at the corresponding input.

NOTE: Neither the status nor history LED illuminates if T1 frame synchronization has not been achieved.
- **AIS:** The red status LED illuminates upon detection of an AIS signal (2048 consecutive unframed 1's). The LED for the corresponding line illuminates to indicate at which input the AIS signal is detected.

*Requires ZBTSI Framing Option.

The red history LED illuminates when AIS is no longer detected at the corresponding input.

7.8 GROUNDING

- Chassis and Signal Grounds: Tied together.
- Bantam and 310 Jack Sleeves: Connected to chassis ground.
- Power Cord Ground: Connected to chassis ground.
- 25-pin D-type Connector: Pin 1 connected to chassis ground.
Pin 7 connected to signal ground.
- Optional 488 Connector: Pin 12 connected to chassis ground.
Pins 18-24 connected to signal ground.
- Test Point Connector: Pin 37 connected to signal ground.
- DS0 Data Connector: Sleeve connected to chassis ground.
- DS0 Tx Clock Connector: Pin 2 connected to signal ground.
Shell connected to chassis ground
- DS0 Rx Clock Connector: Pin 2 connected to signal ground.
Shell connected to chassis ground
- V.35 Connector: Pin A connected to chassis ground.
Pin B connected to signal ground.
- RS-449 Connector: Pin 1 connected to chassis ground.
Pin 19 connected to signal ground.
- 4-Wire VF Connector: Sleeve connected to chassis ground.

SECTION 7

MAINTENANCE AND SERVICE

8.1 INTRODUCTION

This section contains information on T-BERD 224 maintenance and service. Specifically, it describes the steps to take should you experience difficulty operating the T-BERD 224. Instructions for replacing the instrument's line fuse are also included, along with a description of TTC's warranty policies and repair procedures.

8.2 MAINTENANCE

8.2.1 In Case of Difficulty

If the T-BERD 224 fails to operate and no front-panel indicators are illuminated:

- Check the AC power cord to ensure that it is securely connected to the T-BERD 224.
- Make sure that the power supply is uninterrupted by plugging another electrical device into the electrical outlet used by the T-BERD 224.
- Verify that a proper, working AC line fuse is installed. Information on the fuse-type and installation is given in Section 8.2.2.

If the T-BERD 224 fails to operate after the AC power cord, power source, and fuse are determined to be working properly, contact TTC's Customer Service Department by phoning: 1-800-638-2049.

If the front-panel indicators illuminate, but the instrument does not operate properly:

- (1) Use the Instrument Checkout Procedure in Section 3 to localize the problem.
- (2) Note the areas where the self-test failed, then contact TTC for assistance.

SECTION 8

8.2.2 AC Line Fuse Replacement

The T-BERD 224 AC line fuse is stored in the AC fuse receptacle and is located just below the **POWER** switch. If the fuse is open, it should be replaced with a 1A, 250V, Slo-Blo fuse (Littlefuse #218001 or its equivalent). Always use the correct fuse rating.

To replace the AC line fuse, do the following:

- (1) Locate the tab on the fuse cover above the **POWER** switch receptacle.
- (2) Using a small screwdriver or similar instrument, gently pry the fuse cover open.
- (3) Remove the old fuse and install a new fuse of the correct size.
- (4) Press the plastic fuse holder securely back into place.

8.3 SERVICE

8.3.1 Warranty Policy

All equipment manufactured by Telecommunications Techniques Corporation (TTC) is warranted against defects in material and workmanship. This warranty applies only to the original purchaser and is non-transferable unless express written authorization of the warranty transfer is granted by TTC.

Liability under this warranty extends only to the replacement value of the equipment. The warranty is void under the following conditions.

- (1) Equipment has been altered or repaired without specific authorization from TTC.
- (2) Equipment is installed other than in accordance with instructions contained in TTC literature and operating manuals.

No other warranty is expressed or implied. TTC is not liable for consequential damages.

8.3.2 In-Warranty Service

Equipment in warranty must be returned to the factory with shipping prepaid. The equipment should be packed and shipped in accordance with instructions in Section 8.3.4 of this manual. Before returning any equipment, the customer must obtain a Return Authorization (RA) number by contacting the TTC Repair Department. The RA number should then appear on all paperwork and be clearly marked on the outside of the shipping container.

After the equipment is repaired by TTC, it will be tested to applicable specifications, burned-in for at least 24 hours, retested, and returned to the customer with shipping prepaid. A brief description of the work performed and the materials used will be provided on the Equipment Repair Report furnished with the returned equipment.

8.3.3 Out-of-Warranty Service

The procedure for repairing out-of-warranty equipment is the same as that used for equipment still in warranty. However, there is a minimum charge applied to each request for out-of-warranty service. The minimum charge guarantees the customer an estimate of the repair costs and is used as credit against actual materials and labor costs should the equipment be repaired. Contact the TTC Repair Department for specific information on the minimum out-of-warranty charge.

The customer will be billed for parts plus standard labor rates in effect at the time of repair. The customer will also be required to furnish a purchase order number before repair work can be started, and a hard copy of the purchase order must be received by TTC before the repaired equipment may be shipped to the customer. A description of the labor and materials used will be provided in the Equipment Repair Report.

Once an out-of-warranty repair is made, the repaired part or component is warranted for 90 days. This warranty applies only to the part or component that was repaired; other parts or components are not covered under the 90-day repair warranty.

8.3.4 Equipment Return Instructions

To all equipment returned for repair, the customer should attach a tag that includes the following information.

SECTION 8

- (1) Owner's name and address.
- (2) A list of the equipment being returned and the applicable serial number(s).
- (3) A detailed description of the problem or service requested.
- (4) The name and telephone number of the person to contact regarding questions about the repair.
- (5) The Return Authorization (RA) number.

It is recommended that all switches be left in the positions they were in when the problem occurred. This is requested so that the TTC repair group can analyze the switch positions along with a detailed description of the problem or of the service requested.

If possible, the customer should return the equipment using the original shipping container and material. If the original container is not available, the unit should be carefully packed so that it will not be damaged in transit. TTC is not liable for any damage that may occur during shipping. The customer should clearly mark the TTC-issued RA number on the outside of the package and ship it prepaid and insured to TTC.

OPTIONS AND ACCESSORIES

9.1 INTRODUCTION

This section describes the options that are available for the T-BERD 224 PCM Analyzer. In addition, lists of accessories and cables are also provided.

9.2 OPTIONS

The following options provide capabilities for the T-BERD 224 to interface with IEEE-488 controllers, test ZBTSI encoded circuits, perform bit error rate test on a wide range of digital circuits, perform VF measurements, examine SLC-96 and ESF datalinks, and connect the T-BERD 224 to external data communications equipment. Each option is fully described in a separate section. Contact the TTC Customer Service Department for ordering information.

9.2.1 IEEE-488 Remote Control Option

The factory installed IEEE-488 Remote Control Option (Model 41243) allows the T-BERD 224 to communicate with an IEEE-488 compatible device such as a computer, terminal, or printer. The IEEE-488 Remote Control Option complies with the IEEE Standard Interface for Programmable Instrumentation (STD 488-1978).

This interface offers both addressable and talk-only operating modes. In the addressable mode, the T-BERD 224 can be connected to an IEEE-488 bus with up to 14 other devices, one of which must be a controller. In the talk-only mode, the T-BERD 224 is typically connected directly to a listen-only IEEE-488 compatible printer.

Refer to Section 10, IEEE-488 Remote Control Option, for a full description of the IEEE-488 Remote Control Option.

SECTION 9

9.2.2 ZBTSI Framing Option

The Zero Byte Time Slot Interchange (ZBTSI) Framing Option (Model 11425) allows the T-BERD 224 to test and analyze T1 ESF (Extended Superframe) circuits that use ZBTSI encoding.

ZBTSI encoding is used to transmit clear-channel data over T1 AMI line-code facilities. ZBTSI encoding allows continued use of long-haul equipment (e.g., repeaters, multiplexers, line protection equipment, etc.) for clear channel applications which is not compatible with B8ZS coding. With ZBTSI encoding, only the terminal equipment must be modified.

Refer to Section 11, ZBTSI Framing Option, for a full description of the ZBTSI Framing Option.

9.2.3 DSU Data Port Option

The field-installable RS-232/RS-449 (V.35) DSU Data Port (DSU-DP) Option provides full-duplex drop and insert access to synchronous data at a variety of customer data rates. Access is provided to an external bit error rate test (BERT) instrument, protocol analyzer, datascope, or data terminal equipment through the side-panel interface connections. The DSU-DP Option is available in two versions (EIA RS-449 (RS-422) and CCITT V.35); both are configured as DCE and provide the same functionality:

- EIA RS-232-C and EIA RS-449 (RS-422) Interfaces (Model 41441)
- EIA RS-232-C and CCITT V.35 Interfaces (Model 41249)

The DSU-DP Option allows access to the following synchronous data from virtually any T1 access point:

- **DS0A-Framed DDS Data** — Drop and insert access is provided to unformatted primary channel data at 2.4, 4.8, 9.6, 19.2, and 56 kb/s or secondary channel data at 0.133, 0.266, 0.533, 1.066, and 2.667 kb/s. The option provides access to either the primary or secondary channel without disrupting the other channel.
- **DS0B-Framed DDS Data** — Drop and insert access is provided to a single customer's unformatted primary channel data at 2.4, 4.8, and 9.6 kb/s or secondary channel data at 0.133, 0.266, or 0.533

kb/s. The remaining channels are transmitted through the T-BERD 224 without being affected. Once isolated from the other customers within the channel, the data is treated in a similar manner as described for DS0A data.

- **Clear Channel Data** — Drop and insert access is provided to clear channel 64 kb/s data.
- **Fractional T1 Data** — Drop and insert access is provided to fractional T1 data at $64 \times N$ or $56 \times N$ kb/s where N can be any number from 1 to 24. Channels may be contiguous or non-contiguous and may “wrap around” the frame bit. Fractional T1 data can be accessed only when the **MODE** switch is set to T1-ESF, T1-ESFz, or T1-D4.
- **ESF Datalink Data** — Drop and insert access is provided to the 4 kb/s datalink data of an ESF-formatted T1 circuit or the 2 kb/s datalink on ZBTSI encoded signals (requires the ZBTSI Framing Option).

Refer to Section 12, DSU-DP Option, for a full description of the DSU Data Port Interface Option.

9.2.4 T1/Fractional T1/DDS Bit Error Rate Testing Option

The field-installable T1/Fractional T1/DDS Bit Error Rate Testing (BERT) Option (Model 41500) enables the T-BERD 224 to perform out-of-service bit error rate tests with 17 different test patterns, emulate a T1 CSU in loopback, transmit and respond to standard (CSU, facility, and DDS) and programmable loop codes, insert logic, BPV, and frame errors (single, burst, or continuous errors), and test DDS primary and secondary channels. The option also provides LOGIC category results which report on bit errors, bit error rate, error-free seconds, synchronous and asynchronous errored seconds, out-of-synchronization seconds, and pattern slips. Additionally, simplex current and round trip delay measurements are added to the SIGNAL category and DS0 control codes and DDS frame error counts are included in the CHANNEL category.

Refer to Section 13, BERT Option, for a full description of the BERT Option.

SECTION 9

9.2.5 Voice Frequency Option

The field-installable Voice Frequency (VF) Option (Model 41502) provides internal voice frequency transmission impairment measurements for testing analog channels carried on a T1 circuit. This option eliminates the need to attach an external TIMS set to the T-BERD 224's side panel interface for testing VF channels. The VF Option provides VF level, frequency, noise (C-Message, C-Notch, 3 kHz Flat, and 3 kHz-Notch filters), signal-to-noise ratio (S/N), Peak-to-Average Ratio (P/AR), return loss tests (ERL, SRL-HI, and SRL-LO), and automated frequency sweeps for testing VF circuits.

Refer to Section 14, VF Option, for a full description of the VF Option.

9.2.6 Enhanced SLC-96 and ESF Option

The Enhanced SLC-96 and ESF Option (Model 11704) transmits and receives ANSI T1.403 compatible performance report messages on ESF framed T1 circuits. For SLC-96/Series 5 framed circuits, the T-BERD 224 can monitor the A-shelf and capture major, minor, and power alarms, detect maintenance activity, far-end loops, and protection switching events. This option also enables the T-BERD 224 to send alarms and looping information on the datalink for pre-service testing of SLC-96 systems.

Refer to Section 15, Enhanced SLC-96 and ESF Option, for a full description of the Enhanced SLC-96 and ESF Option.

9.3 ACCESSORIES AND CABLES

Various accessories and cables are offered with the T-BERD 224; these accessories are described in the following sections. Contact TTC's Customer Service Department for ordering information.

9.3.1 Accessories

The following is a list of accessories provided to aid in the transport and operation of the T-BERD 224.

Part No.	Description
41306	Soft carrying case
41297	Thermal 40-column graphics lid printer
PR-40A	Thermal 40-column graphics printer w/cable and carrying case
PR-35	Rack mounted Thermal printer (40-column)
41444-01	Rack mount (19")
41444-02	19" to 23" rack mount extension kit

9.3.2 Cables

The following is a list of cables available to provide the interconnection required between the T-BERD 224 and other test equipment or test circuits.

Part No.	Description
10598	WECO 310 plug to WECO 310 plug (4')
10420	WECO 310 plug to WECO 310 plug (10')
10558	WECO 310 plug to alligator clips (10')
10599	WECO 310 plug to bantam plug (4')
10559	WECO 310 plug to bantam plug (10')
10615	Bantam plug to bantam plug (10')
10648	Bantam plug to alligator clips (10')
10213	RS-232 male-to-male (6') ^{1,2}
10418	RS-232 male-to-male (10') ^{1,2}
10214	V.35/306 male-to-male (6') ²
10419	V.35/306 male-to-male (10') ²
30611	9-pin D male to 5-pin audio male (4')
20309	9-pin D male to 9-pin audio male (10')
30901	Dual drop and insert RS-232 adaptor (6') ^{1,2}
30902	Dual drop and insert RS-449 adaptor (6') ¹
30903	Dual drop and insert V.35 adaptor (6') ²
30771	Extender cable for lid printer (8')

¹ For use with Model Number 41441 RS-232/RS-449 DSU Data Port Option.

² For use with Model Number 41249 RS-232/V.35 DSU Data Port Option.

IEEE-488 INTERFACE OPTION

10.1 INTRODUCTION

With the IEEE-488 Interface Option (Model 41243) installed, the T-BERD 224 can communicate with an external device such as a computer, terminal, or printer through the PRINTER/REMOTE IEEE-488 connector. The IEEE-488 Interface Option conforms to the IEEE Standard Digital Interface for Programmable Instrumentation (IEEE STD 488.1-1978).

The IEEE-488 interface offers both Addressable and Talk-Only operating modes. In the Addressable mode, the T-BERD 224 can be connected to an IEEE-488 bus with up to 14 other devices; one of which must be a controller. This enables remote control operation of the T-BERD 224. In the Talk-Only mode, the T-BERD 224 is typically connected directly to a IEEE-488 compatible listen-only printer.

10.2 CONTROLS AND INDICATORS

The only controls used with the IEEE-488 Interface Option are those used to configure the Auxiliary functions AUX 08 RS 232 and AUX 09 488MODE. The AUX 08 RS 232 function is included with the T-BERD 224 Mainframe. The AUX 09 488MODE function is only available when the IEEE-488 Interface Option is installed.

10.2.1 AUX 08 RS 232 — Set PRINTER/REMOTE RS-232 Connector Configuration

AUX 08 RS 232	PARITY NONE	BAUD 9600	TERMINATOR CR
--------------------------	------------------------	----------------------	--------------------------

MODE	CHANNEL FORMAT	SCI	SCII	RESULTS I	RESULTS II
<input type="checkbox"/>	<input type="checkbox"/>	<input type="checkbox"/>	<input type="checkbox"/>	<input type="checkbox"/>	<input type="checkbox"/>

SECTION 10

The AUX 08 RS 232, TERMINATOR, function also sets the line terminator used by the IEEE-488 interface when data is transmitted by the T-BERD 224. Press the **RESULTS II Results** switch to select the desired line terminator character: CR (default), LF, or CRLF. The parity and baud selections do not apply to the IEEE-488 interface.

10.2.2 AUX 09 488MODE — IEEE-488 Mode and Address Connector Configuration

AUX 09 488MODE	IEEE-488 MO DE and ADDR	ESS
	ADDR:	SRQ: ON
	0	

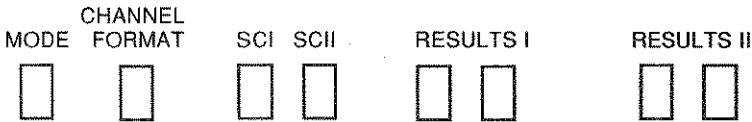

The AUX 09 488MODE function selects between either the Addressable or Talk-Only operating mode. The Auxiliary function also sets the bus address and the Service Request (SRQ) function in the Addressable mode. The factory default is set for Addressable operating mode, the bus address set to 0, and SRQ is OFF. Press the **SOURCE CONFIGURATION II (SCII)** switch to select the desired interface operating mode:

Talk-Only Mode — Select this mode when the T-BERD 224 is connected to an IEEE-488 compatible listen-only printer. When selecting the Talk-Only mode, refer to Section 10.4, IEEE-488 Printer Operation, for set-up and operating procedures.

Addressable Mode — Select this mode when the T-BERD 224 is being connected to an IEEE-488 bus. The Addressable mode allows the T-BERD 224 to be assigned a unique bus address which is used by the IEEE-488 controller to identify the devices connected to the IEEE-488 bus. The SRQ state is also selectable in this mode.

- **ADDR:** — Press the **RESULTS I Category** switch to select the desired bus address from 0 to 30. The bus address must be unique for each device connected to the same bus.

- **SRQ** — Press the **RESULTS II Results** switch to turn the SRQ function ON or OFF. With the SRQ set to ON, an SRQ is generated when an erroneous command is received or data is ready to be sent.

When selecting the Addressable mode, refer to Section 10.5, IEEE-488 Remote Control Operation, for set-up and operating procedures to operate the T-BERD 224 from an IEEE-488 controller.

10.3 CONNECTIONS

The IEEE-488 interface connection is located on the right side of the T-BERD 224 above the RS-232-C interface connector, first slot. Table 10-1 lists the pin assignments and associated functions for the PRINTER/REMOTE IEEE-488 connector.

Table 10-1
PRINTER/REMOTE IEEE-488 Connector Pin Assignments

Pin No.	Description	Pin No.	Description
1	Data In/Out 1 (DI/O1)	13	Data In/Out x (DI/O5)
2	Data In/Out 2 (DI/O2)	14	Data In/Out x (DI/O6)
3	Data In/Out 3 (DI/O3)	15	Data In/Out x (DI/O7)
4	Data In/Out 4 (DI/O4)	16	Data In/Out x (DI/O8)
5	End or Identify (EOI)	17	Remote Enable (REN)
6	Data Valid (DAV)	18	Gnd for twisted pair for 6
7	Not Ready for Data (NRFD)	19	Gnd for twisted pair for 7
8	Not Data Accepted (NDAC)	20	Gnd for twisted pair for 8
9	Interface Clear (IFC)	21	Gnd for twisted pair for 9
10	Service Request (SRQ)	22	Gnd for twisted pair for 10
11	Attention (ATN)	23	Gnd for twisted pair for 11
12	SHIELD	24	Signal Gnd

10.4 IEEE-488 PRINTER OPERATION

The T-BERD 224 can drive an IEEE-488 listen-only printer by selecting the TALK-ONLY mode. In Talk-Only mode, the T-BERD 224 only outputs data to the PRINTER/REMOTE IEEE-488 connector and cannot be controlled by a remote control device on the RS-232-C interface.

Perform the following procedure to configure the T-BERD 224 to operate with an IEEE-488 compatible printer.

- (1) Turn the T-BERD 224 ON.
- (2) Press the **AUX** switch to display the Auxiliary functions and the **MODE** switch to select the AUX 08 RS 232 function.
- (3) Press the **RESULTS II Results** switch to select the desired line terminator: CR, LF, or CRLF (see Section 10.2.1, AUX 08 RS 232 — Set PRINTER/REMOTE RS-232 Connector Configuration).
- (4) Press the **MODE** switch to select the AUX 09 488MODE function.
- (5) Press the **SCII** switch to select the TALK-ONLY mode (see Section 10.2.2, AUX 09 488MODE — IEEE-488 Mode and Address Connector Configuration).
- (6) Connect the printer to the T-BERD 224 IEEE-488 interface with an appropriate cable.
- (7) Turn the printer ON; if necessary place the printer on line.
- (8) Press either the **PRINT CONTROLS** switch or **PRINT RESULTS** switch to verify that the printer is generating the appropriate printout. If the print buffer is not cleared, previously stored printouts are printed first.

Refer to Section 5, Printer Operation, for additional information on the available printouts from the T-BERD 224.

10.5 IEEE-488 REMOTE CONTROL OPERATION

Prior knowledge of IEEE-488 controller programming and operation is recommended before attempting to operate the T-BERD 224 through the

PRINTER/REMOTE IEEE-488 connector. The following sections describe how to set-up and operate the T-BERD 224 from an IEEE-488 controller. Refer to Section 6, Remote Control Operation, for additional remote control procedures and commands.

10.5.1 T-BERD 224 Remote Control Set-Up Procedure

Perform the following procedure to configure the T-BERD 224 to operate with an IEEE-488 compatible controller.

- (1) Turn the T-BERD 224 and controller ON.
- (2) Press the **AUX** switch and the **MODE** switch to select the AUX 08 RS 232 function.
- (3) Press the **RESULTS II Results** switch to select the desired line terminator: CR, LF, or CRLF (see Section 10.2.1, AUX 08 RS 232 — Set PRINTER/REMOTE RS-232 Connector Configuration).
- (4) Press the **MODE** switch to select the AUX 09 488MODE function.
- (5) Press the **SCII** switch to select the ADDRESS mode (see Section 10.2.2, AUX 09 488MODE — IEEE-488 Mode and Address Connector Configuration).
- (6) Press the **RESULTS I Category** switch to select the desired T-BERD 224 bus address from 0 to 30. The bus address must be unique for each device connected to the same bus (see Section 10.2.2, AUX 09 488MODE — IEEE-488 Mode and Address Connector Configuration).
- (7) Connect the controller bus to the T-BERD 224 IEEE-488 interface with an appropriate cable.
- (8) Perform the necessary controller programming to gain access and control over the T-BERD 224. Refer to the IEEE-488 controller operating manual for the appropriate programming instructions.

10.6.2 Functional Description

In the Addressable remote control mode, the T-BERD 224 bus address must be set to a value between 0 and 30. This address is used by the

SECTION 10

controller to determine which device is being addressed. Using the T-BERD 224 bus address, the controller can designate the T-BERD 224 to "listen" (receive remote commands) or to "talk" (send data). The T-BERD 224 responds to the IEEE-488 Device Clear (DCL) command by performing another power-up. When entering IEEE-488 remote control, all MESSAGES are set to OFF (refer to Section 6.5, Remote Control Commands, for the MESSAGES command).

Unlike an RS-232 connection, the IEEE-488 bus requires that one device on the bus act as a controller. All other devices connected to the bus must act as slaves to that controller. The T-BERD 224 can only act as a slave; another intelligent device must act as the bus controller. A device which is commonly used as a controller is the IBM-PC with a National Instruments GPIB-PC interface card and system software.

The following steps are typically performed during a remote control input sequence.

- (1) The controller device addresses the T-BERD 224 to listen.
- (2) The controller sends a valid remote control command.
- (3) The controller sends a valid remote control line terminator.
- (4) Upon receiving the line terminator, the T-BERD 224 analyzes the remote command and performs the appropriate action.

When receiving characters, ASCII null and space characters are discarded and the remaining characters are saved until the line terminator is received. Upon receipt of the line terminator, the received command is analyzed. If no error is detected, the T-BERD 224 performs the appropriate action and then prepares to receive another command. However, if an error is detected in the command string, an SRQ is issued and the least significant bit (LSB) of the serial poll register is set. If a response is appropriate, the most significant bit (MSB) is set and an SRQ is issued. If this response is not read by the controller before the next command is sent, the response is discarded.

If the AUX 09 488MODE, SRQ, function is set to ON, the T-BERD 224 generates an SRQ whenever an erroneous command is received, or when it has data ready to transmit. If the SRQ function is set to OFF, the T-BERD 224 sets the appropriate serial poll register bit, but does not issue an SRQ. Figure 10-1 identifies the control bits that affect the T-BERD 224.

B7	B6	B5	B4	B3	B2	B1	B0
dav	rsv						syn

dav = data available in T-BERD 224 print buffer

rsv = request service (SRQ)

syn = command syntax error

Figure 10-1
Serial Poll Register Byte

The line terminator transmitted from the T-BERD 224 may be set to carriage return (CR), linefeed (LF), or both (CRLF). Use the AUX 08 RS 232, TERMINATOR, function to set the line terminator for both RS-232 and IEEE-488 operation. Regardless of the mode or line terminator selection, the EOI signal is raised with the final character of an entire printout.

10.5.3 IEEE-488 Programming Hints

Before attempting to read data from a device, it is necessary to know if the device has data to send. The controller has two ways of determining that the T-BERD 224 has data: (1) Bit 7 of the serial poll register (dav) is set whenever a line of data is available and (2) if the AUX 09 488MODE, SRQ, function is set to ON, the T-BERD 224 sends an SRQ to the IEEE-488 controller whenever it has data available. An SRQ can also occur when a syntax error is detected.

The statement used to read data from the T-BERD 224 must be one that terminates the read operation when the last character of the line is encountered. The most foolproof way to detect the last character is by sensing the EOI signal.

10.5.4 Error Messages

The following remote control error message can occur when operating from the IEEE-488 interface. Additional error messages can be found in Section 6.4, Error Messages.

SECTION 10

ERROR: *Command not valid in 488 remote control*

A command was entered that is not applicable during IEEE-488 operation.

10.5.4 Remote Control Commands

The following remote control commands are directly related to the set-up and operation of the IEEE-488 interface when controlling the T-BERD 224 from an IEEE-488 controller.

- **488 ADD** IEEE-488 Address
- **488 MOD** IEEE-488 Mode
- **488 SRQ** IEEE-488 SRQ
- **PRI TER** Printer Terminator

The following remote control commands *cannot* be used when controlling the T-BERD 224 from an IEEE-488 controller. The error message shown in Section 10.5.4, Error Messages, occurs when any of these commands are used.

- **CLS** Clear the Terminal Screen
- **COMPUTER** Configure the T-BERD 224 for Remote Control Operation
- **DEVICE CLEAR** Reinitialize Device
- **ECHO** Echo Mode
- **LOCAL** Return the T-BERD 224 to Local Mode
- **PROMPT** Terminal Remote Control Prompt
- **REMOTE** Remote Control Entry
- **TERMINAL** Configure the T-BERD 224 for Terminal Remote Control Operation

Refer to Section 6, Remote Control Operation, for additional information on the T-BERD 224 remote control capabilities and complete descriptions of the remote control commands.

488 ADD**488 ADD**

IEEE-488 Address

488 ADD? :Displays the current IEEE-488 address for the T-BERD 224

488 ADD [xx] :Sets the IEEE-488 address, where xx = 1 to 30

488 ADD sets the T-BERD 224 address for the IEEE-488 controller to use when communicating across the bus. The address selected for the T-BERD 224 should be unique, with no other device on the bus having the same address.

This command is identical to the AUX 09 488MODE function.

EXAMPLE:

> **488 ADD?** :displays the current IEEE-488 address

488 ADDRESS 10

> **488 ADD 07** :set the IEEE-488 address to 07

>

SECTION 10**488 MOD****488 MOD****IEEE-488 Mode**

488 MOD? :Displays the current status for the IEEE-488 mode

488 MOD [TAL|ADD] :Sets the IEEE-488 mode

488 MOD is used to determine the operating mode for the IEEE-488 Interface. Selecting **488 MOD TAL** configures the IEEE-488 Interface to output information to the printer connected to the front panel AUXILIARY PORT. Selecting **488 MOD ADD** configures the IEEE-488 interface to the addressable mode. In the addressable mode, the T-BERD 224 can both receive commands and return information across the bus.

This command is identical to the AUX 09 488MODE function.

NOTE: This command is not available from the IEEE-488 remote control.

EXAMPLE:

> **488 MOD?** :displays the current IEEE-488 interface mode
488 MODE TALk

> **488 MOD ADD** :set the IEEE-488 Interface to the address mode

>

488 SRQ**488 SRQ****IEEE-488 SRQ**

- 488 SRQ?** :Displays the current status for the IEEE-488 SRQ
- 488 SRQ [ON|OFF]** :Sets the IEEE-488 SRQ

488 SRQ ON allows the T-BERD 224 to generate a SRQ (service request) when it has data to transmit and asserts Bit 7 dav (data available) and Bit 6 rsv (request service (SRQ)) of the serial poll status byte. When **488 SRQ OFF** is selected, no SRQ is asserted when data is ready to be transmitted, but Bit 7 dav (data available) is still asserted.

This command is identical to the AUX 09 488MODE function.

EXAMPLE:

- > 488 SRQ?** :displays the current IEEE-488 interface SRQ status
- 488 SRQ OFF
- > 488 SRQ ON** :enables the IEEE-488 SRQ assertion
- >**

10.6 SPECIFICATIONS

- Connector Type: 24-pin, D-type.
- Connector Configuration: Addressable or Talk-Only.
- Connector Pin Configuration: See Table 10-1.
- Maximum Transfer Rate: 1200 b/s.
- Line terminator: CR, LF, or CRLF.

ZBTSI FRAMING OPTION

11.1 INTRODUCTION

The ZBTSI (Zero Byte Time Slot Interchange) Framing Option (Model 11425) allows the T-BERD 224 to test and analyze T1 Extended Superframe (T1-ESF) circuits that use ZBTSI encoding. Unless otherwise indicated, the previous T-BERD 224 functions and capabilities still apply. Additional capabilities are provided when the following options are installed.

EIA RS-232-C/EIA RS-449 DSU-DP Option — This option (Model 41441) adds an EIA RS-232-C and EIA RS-449 drop and insert interface for external testing of unformatted fractional T1, DS0A, DS0B, and ESF and ESFz datalink signals. Refer to Section 12, DSU-DP Interface Option, for additional information.

EIA RS-232-C/CCITT V.35 DSU-DP Option — This option (Model 41249) adds an EIA RS-232-C and CCITT V.35 drop and insert interface for external testing of unformatted fractional T1, DS0A, DS0B, and ESF and ESFz datalink signals. Refer to Section 12, DSU-DP Interface Option, for additional information.

Bit Error Rate Test Option — This option (Model 41500) adds bit error rate testing, CSU, facility, DDS, and ESF datalink loopback control, enhanced BPV, logic, and frame error insertion, DS1 CSU emulation, simplex current and round-trip delay measurements, DDS primary and secondary channel testing, and full unframed, framed, and fractional T1 testing capabilities. Refer to Section 13, Bit Error Rate Test Option, for additional information.

Voice Frequency Option — This option (Model 41502) adds Voice Frequency (VF) test and analysis capabilities. Refer to Section 14, Voice Frequency Option, for additional information.

Enhanced SLC-96 and ESF Option — This option (Model 11704) adds ANSI T1.403 ESF(z) datalink PRM collection and transmission capabilities when testing ESF and ESFz signals. The option also adds SLC-96 alarm, protection line switching, maintenance status, and far-end loop collection and transmission capabilities when testing SLC-96 systems. Refer to Section 15, Enhanced ESF and SLC-96 Option, for additional information.

SECTION 11

For additional information on other options, refer to Section 9, Options and Accessories.

11.2 OPERATION AND SIGNAL FLOW

ZBTSI encoding is typically used to transmit clear-channel data over T1 Alternate Mark Inversion (AMI-encoded) facilities. ZBTSI encoding allows continued use of long-haul equipment (e.g., repeaters, multiplexers, line protection equipment, etc.) for clear channel applications equipment that is not B8ZS compatible. With ZBTSI encoding, only the terminal equipment is modified.

ZBTSI encoding changes the 24 ESF frames from 576 octets (octets are groups of eight bits) into six blocks of 96 octets (four frames) each. These 96 octets are then rearranged, depending on the data content of each octet. The contents of an individual octet are examined to determine whether that octet has an all-zeros condition. The way the ZBTSI signal is processed depends on the number of octets that violate the all-zeros condition.

ZBTSI encoding follows a six-step process, as follows:

- (1) The data is loaded into a buffer, one octet at a time, until 96 octets are stored in the buffer and numbered accordingly (1 to 96).
- (2) The contents of all 96 octets are examined to identify any that contain an all-zero condition. If no all-zero octets exist, the 96 octets exit the buffer and the next 96 octets are loaded into the buffer. However, if one or more octets contain all zeros, their octet number is noted, then the octet(s) is removed from the buffer. Removing the all-zero octets leave eight-bit gaps.
- (3) The other non-zero octets are shifted to fill any eight-bit gaps. This shifting creates gaps at the front of the 96 octets.
- (4) An address byte is inserted in the first eight-bit gap; the first seven of the eight bits of this octet provide a binary address where the all-zero octet was previously located; Bit 8 is used to indicate whether there are additional all-zero octets following. (If Bit 8 is set to a 0, more all-zero octets follow; if Bit 8 is set to 1, no other all-zero octets follow.)

- (5) When ZBTSI encoding is used, the 24 framing bits are assigned as follows: six Frame Pattern Sequence (FPS) bits, six Cyclic Redundancy Check (CRC-6) bits, six datalink (DL) bits, and six Z bits. Half of the original ESF datalink is used to provide the Z bits used in the ZBTSI algorithm. The Z bits are used to indicate if ZBTSI encoding occurred in the next 96 octet grouping.
- (6) The 96 octets exit the buffer.

The T-BERD 224 operating mode can be set for ZBTSI encoding by selecting T1-ESFz or AUTO mode. In AUTO mode, the T-BERD 224 automatically detects and configures itself for ZBTSI-encoded operation.

NOTE: When the T-BERD 224 is placed in-line to test channels within a ZBTSI-encoded circuit and the **MODE** switch is set to T1-ESFz, the T-BERD 224 adds an additional four frames of transmission delay (500 microseconds) to the 19 bits of delay typically encountered in other modes.

11.3 CONTROLS AND INDICATORS

The ZBTSI-encoded operating mode is selected by pressing the **MODE** switch until "T1-ESFz" appears in the MODE display. The T1-ESFz mode configures the T-BERD 224 to transmit and receive ZBTSI encoded ESF framed T1 data which enables the T-BERD 224 to test ZBTSI-encoded circuits.

Unless otherwise indicated, the switch information described in Section 2, Instrument Description, also applies to the ZBTSI Framing Option.

11.4 REMOTE CONTROL OPERATION

The following remote control commands are directly related to the set up and operation of the ZBTSI Framing Option when the T-BERD 224 is controlled from a remote control device.

- **MOD T1ESFZ** T1 rate with ESF ZBTSI framing mode.

SECTION 11

- **HELLO**

Display the T-BERD 224 Software Revision Level. The ZBTSI Framing Option is listed when the command is used.

Refer to Section 6, Remote Control Operation, for additional information on the T-BERD 224 remote control capabilities and complete descriptions of the remote control commands.

DSU-DP OPTION

12.1 INTRODUCTION

This section describes the features, functional operation, and specifications of the DSU Data Port Interface Option (DSU-DP Option) when it is installed in the T-BERD 224 PCM Analyzer.

12.1.1 Standard Features

The DSU-DP Option provides full-duplex drop and insert access to synchronous data at a variety of customer data rates. Access can be provided to an external bit error rate test (BERT) instrument, protocol analyzer, or data scope via one of the side-panel interfaces. The DSU-DP Option is available in two versions; both are configured as DCE and provide the same functionality:

- RS-232 and RS-449 (RS-422) Interfaces (Part Number 41441)
- RS-232 and V.35 Interfaces (Part Number 41249)

When installed in the T-BERD 224, the DSU-DP Option allows users to access the following synchronous data from virtually any T1 access point:

DS0A-Encoded DDS Data — Drop and insert access is provided to unformatted PRIMARY channel data at 2.4, 4.8, 9.6, 19.2, and 56 kb/s or SECONDARY channel data at 0.133, 0.266, 0.533, 1.066, and 2.667 kb/s. When accessing a DDS channel, the DSU-DP Option will provide access to either the PRIMARY or SECONDARY channel without disrupting the other channel. AUX 11 ANL CHA determines which channel is provided for test purposes. Where applicable, control and frame bits are stripped from the data before being sent to an external test set; these bits are added when data is received from the external test set before being multiplexed into the T1 data stream. When dropping DS0A 9.6, 4.8 or 2.4 kb/s subrate data from the T1 to an external test set, the DSU-DP provides data from one of the repeated byte sequences or from a majority rule error-correction as designated in AUX 12 ERR COR.

SECTION 12

NOTE: Since access to the control bit (bit 8) is not provided, DDS control and loop codes cannot be transmitted via the DSU-DP Option interfaces. Loop backs may be established using either a hard loop at the desired location, a KS-type test set at the DS0 Interface to transmit specific loop codes, or with the BERT Option, if installed.

DS0B-Encoded DDS Data — Drop and insert access is provided to a single customer's unformatted PRIMARY channel data at 2.4, 4.8, and 9.6 kb/s or SECONDARY channel data at 0.133, 0.266, or 0.533 kb/s. The remaining 19, 9, and 4 customers, respectively, are transmitted through the T-BERD 224 without being affected. Once isolated from the other customers within the channel, the data is treated in a similar manner as described for DS0A data, except that there is no provision for error correction.

NOTE: Since access to the control bit (bit 8) is not provided, DDS control and loop codes cannot be transmitted via the DSU-DP Option interfaces. Loop backs may be established using either a hard loop at the desired location, a KS-type test set at the DS0 Interface to transmit specific loop codes, or with the BERT Option, if installed.

Clear Channel Data — Drop and insert access is provided to clear channel 64 kb/s data.

Fractional T1 Data — Drop and insert access is provided to fractional T1 data at $64 \times N$ or $56 \times N$ kb/s where N can be any number from 1 to 24. Channels may be contiguous or non-contiguous and may "wrap around" the frame bit. Contiguous channels are selected by choosing an N value and then selecting the first channel in the fractional T1 sequence using each line's **CHANNEL** switch. Non-contiguous channels are selected by choosing NON CONTIG with the **SOURCE CONFIGURATION II (SCII)** switch and then selecting the desired channels using AUX 10 N-CONTG. Fractional T1 data can be accessed only when the **MODE** switch is set to T1-ESF, T1-ESFz, or T1-D4.

ESF Data Link Data — Drop and insert access is provided to the 4 kb/s datalink data of an ESF-formatted T1 circuit.

ZBTSI Data Link Data — Drop and insert access is provided to the 2 kb/s datalink data of a ZBTSI-encoded ESF-formatted T1 circuit.*

*Requires the ZBTSI Framing Option.

12.1.2 Optional Features

The following T-BERD 224 options are available and can be used with the DSU-DP Option (Model 41441) installed:

ZBTSI Framing Option (Model 11425) — This option allows the T-BERD 224 to test and analyze T1 ESF (Extended Superframe) circuits that use ZBTSI encoding. Refer to Section 11, ZBTSI Framing Option, for additional information.

BERT Option (Model 41500) — This option enables the T-BERD 224 to perform out-of-service bit error rate tests with 18 different test patterns, emulate a T1 CSU in loopback, measure simplex current and round trip delay, transmit and respond to standard (CSU/facility) and programmable loop codes, transmit DDS loop codes, insert logic, BPV, and frame errors (single, burst, or continuous errors). Refer to Section 13, Bit Error Rate Test Option, for a full description of the BERT Option.

VF Option (Model 41502) — This option enables the T-BERD 224 to perform out-of-service voice frequency (VF) tests that provide measurements of voice-grade noise (C-Message and C-Notch noise), signal-to-noise ratio (S/N), data-grade noise (3 kHz Flat and 3 kHz Notch noise), return loss values (ERL, SRL-HI, and SRL-LO), peak-to-average ratio value (P/AR), DC-offset, and VF frequency and level. Refer to Section 14, VF Option, for a full description of the VF Option.

Enhanced ESF/SLC-96 Option (Model 11704) — This option enables the T-BERD 224 to monitor and transmit T1.403 performance report messages (PRMs) on ESF and ESFz framed circuits; monitor major, minor, power, and miscellaneous alarms; detect protection switches and maintenance activity on SLC-96 framed circuits; and send major, minor, and power alarms, as well as perform far-end loops on SLC-96 framed circuits. Refer to Section 15, Enhanced ESF and SLC-96 Option, for additional information.

For ordering information on these optional features, refer to Section 9, Options and Accessories. For more detailed descriptions of these optional features refer to the indicated sections.

12.2 FUNCTIONAL DESCRIPTION

The DSU-DP Option provides a dropped channel(s) to the DSU-DP interface for analysis by an external BERT, KS-type DDS, protocol analyzer, or data scope test set.

The T-BERD 224 DSU-DP Option provides the following data channel applications:

- Decipher and analyze DS0A, DS0B, or fractional T1 circuit protocol using the DSU-DP Option and an external data scope or protocol analyzer.
- Verify bidirectional signaling of primary rate ISDN circuits with an external data scope or protocol analyzer through the DSU-DP interfaces.
- Replace fractional T1 DSU/CSUs by terminating the T1 span and connecting customer DTE to the T-BERD 224's DSU-DP.

When inserting Fractional T1 data into N channels, the remaining 24-N channels are transmitted without being disrupted.

12.3 CONTROLS AND INDICATORS

The following controls and indicators are affected by the DSU-DP Option. Unless otherwise indicated, the switch information described in Section 2, Instrument Description, also applies.

- **AUX** Switch
- **CHANNEL FORMAT** Switch
- **SOURCE CONFIGURATION I (SCI)** Switch
- **SOURCE CONFIGURATION II (SCII)** Switch
- **CHANNEL** Switches

12.3.1 AUX Switch

The following auxiliary functions are added by the DSU-DP Option (Refer to Section 12.5, Auxiliary Functions):

- **AUX 10 N-CONTG** — Non-Contiguous Channel Drop and Insert.
- **AUX 11 ANL CHA** — Set DSU-DP Analysis Channel.
- **AUX 12 ERR COR** — DS0A Error Correction.

12.3.2 CHANNEL FORMAT Switch

The **CHANNEL FORMAT** switch selects the type of test performed. The following additional channel formats are available when the **CHANNEL FORMAT** switch is pressed:

- **DS0A2.4** — Use when monitoring or testing DS0A-formatted DDS data at 2.4 kb/s. Drop and insert access to unformatted 2.4 kb/s data is provided via one of the DSU-DP Option interfaces. PRIMARY or SECONDARY channel data is analyzed using AUX 11 ANL CHA without disrupting the opposite channel. Users may choose to receive data sampled from repeated bytes or data processed using majority rule error correction via AUX 12 ERR COR.
- **DS0A4.8** — Use when monitoring or testing DS0A-formatted DDS data at 4.8 kb/s. Drop and insert access to unformatted 4.8 kb/s data is provided via one of the DSU-DP Option interfaces. PRIMARY or SECONDARY channel data is analyzed using AUX 11 ANL CHA without disrupting the opposite channel. Users may choose to receive data sampled from repeated bytes or data processed using majority rule error correction via AUX 12 ERR COR.
- **DS0A9.6** — Use when monitoring or testing DS0A-formatted DDS data at 9.6 kb/s. Drop and insert access to unformatted 9.6 kb/s data is provided via one of the DSU-DP Option interfaces. PRIMARY or SECONDARY channel data is analyzed using AUX 11 ANL CHA without disrupting the opposite channel. Users may choose to receive data sampled from repeated bytes or data processed using majority rule error correction via AUX 12 ERR COR.

- **DS019.2** — Use when monitoring or testing DSOA-formatted DDS data at 19.2 kb/s. Drop and insert access to unformatted 19.2 kb/s data is provided via one of the DSU-DP Option interfaces. When inserting test data into a T1 time slot, data is inserted in bytes 2 and 3, while bytes 1, 4, and 5 pass through unaffected. If no T1 signal is being received, the all ones pattern is placed in bytes 1, 4, and 5. PRIMARY or SECONDARY channel data is analyzed using AUX 11 ANL CHA without disrupting the opposite channel. When receive signal is present, the subrate frame synchronization must be acquired before the T-BERD 224 will insert test data.
- **DS0A56** — Use when monitoring or testing DSOA-formatted DDS data at 56 kb/s. Drop and insert access to unformatted 56 kb/s data is provided via one of the DSU-DP Option interfaces. PRIMARY or SECONDARY channel data is analyzed using AUX 11 ANL CHA without disrupting the opposite channel.
- **DS064** — Use when monitoring or testing clear channel 64 kb/s data. Drop and insert access to clear channel data is provided via one of the DSU-DP Option interfaces.
- **DS0B2.4** — Use when monitoring or testing DSOB-formatted DDS data at 2.4 kb/s. Drop and insert access to a single customer's unformatted 2.4 kb/s data provided via one of the DSU-DP Option interfaces. Use **SOURCE CONFIGURATION II (SCII)** switch to select one of the 20 DSOB channels to be analyzed. PRIMARY or SECONDARY channel data may be tested without disrupting the opposite channel, or the remaining 19 DSOB channels, via AUX 11 ANL CHA. Note that subrate frame synchronization must be acquired before the T-BERD 224 will insert test data.
- **DS0B4.8** — Use when monitoring or testing DSOB-formatted DDS data at 4.8 kb/s. Drop and insert access to a single customer's unformatted 4.8 kb/s data provided via one of the DSU-DP Option interfaces. Use **SCII** switch to select one of the 10 DSOB channels to be analyzed. PRIMARY or SECONDARY channel data may be tested without disrupting the opposite channel or the other 9 DSOB channels via AUX 11 ANL CHA. Note that subrate frame synchronization must be acquired before the T-BERD 224 will insert test data.
- **DS0B9.6** — Use when monitoring or testing DSOB-formatted DDS data at 9.6 kb/s. Drop and insert access to a single customer's unformatted 9.6 kb/s data provided via one of the DSU-DP Option

interfaces. Use **SCII** switch to select one of the 50 DS0B channels to be analyzed. **PRIMARY** or **SECONDARY** channel data may be tested without disrupting the opposite channel or the other 4 DS0B channels via **AUX 11 ANL CHA**. Note that subrate frame synchronization must be acquired before the **T-BERD 224** will insert test data.

- **56xN** — Use when monitoring or testing 56xN Fractional T1 circuits. Provides drop and insert access to bits 1-7 of 1 to 24 contiguous DS0 channels or up to 23 non-contiguous DS0 channels via one of the DSU-DP Option interfaces. Non-contiguous channels are selected using **AUX 10 N-CONTG**. Note that this selection is only available when **MODE** is set to D4, ESF, or ESFz.
- **64xN** — Use when monitoring or testing 64xN Fractional T1 circuits. Provides access to bits 1-8 of 1 to 24 contiguous DS0 channels or up to 23 non-contiguous DS0 channels via one of the DSU-DP Option interfaces. Non-contiguous channels are selected using **AUX 10 N-CONTG**. Note that this selection is only available when **MODE** is set to D4, ESF, or ESFz.
- **DATLINK** — Use when monitoring or testing either the 4 kb/s datalink of an ESF-formatted circuit or the 2 kb/s datalink of an ESF ZBTISI-formatted circuit (ZBTISI Framing Option required).

12.3.3 SOURCE CONFIGURATION I Switch

With the **CHANNEL FORMAT** switch set to DS0A2.4, DS0A4.8, DS0A9.6, DS0A19.2, DS0A56, DS064, DS0B2.4, DS0B4.8, DS0B9.6, 56xN, 64xN or **DATLINK**, the **SOURCE CONFIGURATION I (SCI)** switch selection added by the DSU-DP Option is:

- **DSU-DP** — This selection enables the side panel's DSU-DP Option interfaces (RS-232, V.35, RS-449) as the drop and insert source. Data is transmitted at the rate indicated in the **CHANNEL FORMAT** display. See Section 12.6, Testing, for more information regarding signal flow and cabling.

12.3.4 SOURCE CONFIGURATION II Switch

The **SCII** switch selections are only available for certain combinations of **CHANNEL FORMATS** and **SCI** switch selections. These combinations

SECTION 12

are displayed in Tables 12-1 and 12-2, and they are described in the following paragraphs, including a brief explanation of the **SCII** switch selections for each combination.

When the **CHANNEL FORMAT** switch is set to DS0B2.4, DS0B4.8 or DS0B9.6, the available **SCII** switch selections are:

- **CHAN = (1-5, 1-10, or 1-20)** — This selection allows the user to choose which one of the 5 (9.6 kb/s), 10 (4.8 kb/s), or 20 (2.4 kb/s) customers within the DS0B-formatted DDS channel to analyze. The remaining 4, 9, or 19 customers are unaffected.

When the **CHANNEL FORMAT** is set to 56xN or 64xN, the available **SCII** switch selections are:

- **N = (1-24)** — This selection allows the user to choose how many contiguous DS0s to analyze as a single bandwidth. The **LINE 1** and **LINE 2 CHANNEL** switches determine where the fractional T1 bandwidth begins.

NOTE: DS0s may “wrap around” the frame bit. For example, if $N=2$ and **CHANNEL** = 24, then channels 24 and 1 are analyzed.

- **NON CONTIG** — This selection allows the user to analyze non-contiguous DS0s as a single bandwidth. When this selection appears in the display, press the front panel **AUX** switch to immediately enter **AUX 10 N-CONTG** so that the necessary channel numbers for each line may be selected in incrementing order.

NOTE: The number of channels for **LINE 1** and **LINE 2** must be the same so that an equal bandwidth for each line is analyzed.

12.3.5 CHANNEL Switches

When the **SCII** switch is set to **NON CONTIG** the channel number is displayed as “—” because the channel(s) to be used are defined by **AUX 10 N-CONTG**.

Table 12-1
DSU-DP Option Switch Configurations

Switch/Aux Function		Configuration				
MODE Switch		T1-D4, T1-ESF, T1-ESFz, T1-TLB, T1-LLB, AUTO				
CHANNEL FORMAT Switch	DS0A2.4	DS0B2.4	DS0B4.8	DS0B9.6	56xN	
	DS0A4.8				64xN	
	DS0A9.6					
	DS019.2					
	DS0A56					
	DS064 DATLINK*					
SCI	DSU-DP	DSU-DP	DSU-DP	DSU-DP	DSU-DP	
SCII		CHAN 1	CHAN 1	CHAN 1	CHAN 1	N = 1
		•	•	•	•	•
		CHAN 20	CHAN 10	CHAN 5	CHAN 5	N = 24 NON CONTIG
AUX 10 N-CONTG						X
AUX 11 ANL CHA	X	X	X	X		
AUX 12 ERR COR	X**					

* DATLINK is not available in the T1-D4 mode.

**ERR COR only applies to DS0A2.4, DS0A4.8, and DS0A9.6 channel formats.

Table 12-2
DSU-DP Option T1 SLC-96 Switch Configurations

Switch/Aux Function	Configuration			
MODE	T1 SLC-96, T1-D1D, T1-D2			
CHANNEL FORMAT Switch	DS0A2.4 DS0A4.8 DS0A9.6 DS019.2 DS0A56 DS064	DS0B2.4	DS0B4.8	DS0B9.6
SCI Switch	DSU-DP	DSU-DP	DSU-DP	DSU-DP
SCII Switch		CHAN 1 • • • CHAN 20	CHAN 1 • • • CHAN 10	CHAN 1 • • • CHAN 5
AUX 10 N-CONTG				
AUX 11 ANL CHA	X	X	X	X
AUX 12 ERR COR	X			

12.4 DSU-DP OPTION CONNECTIONS

The DSU-DP Option's side panel connections are shown in Figure 12-1.

12.4.1 DSU-DP Option Interfaces

Two versions of the DSU-DP Option are provided: RS-232/V.35 and RS-232/RS-449. Both versions provide identical functions, with the only difference being the interfaces offered. For further information regarding the DSU-DP pin configuration, refer to Section 12.9, Specifications.

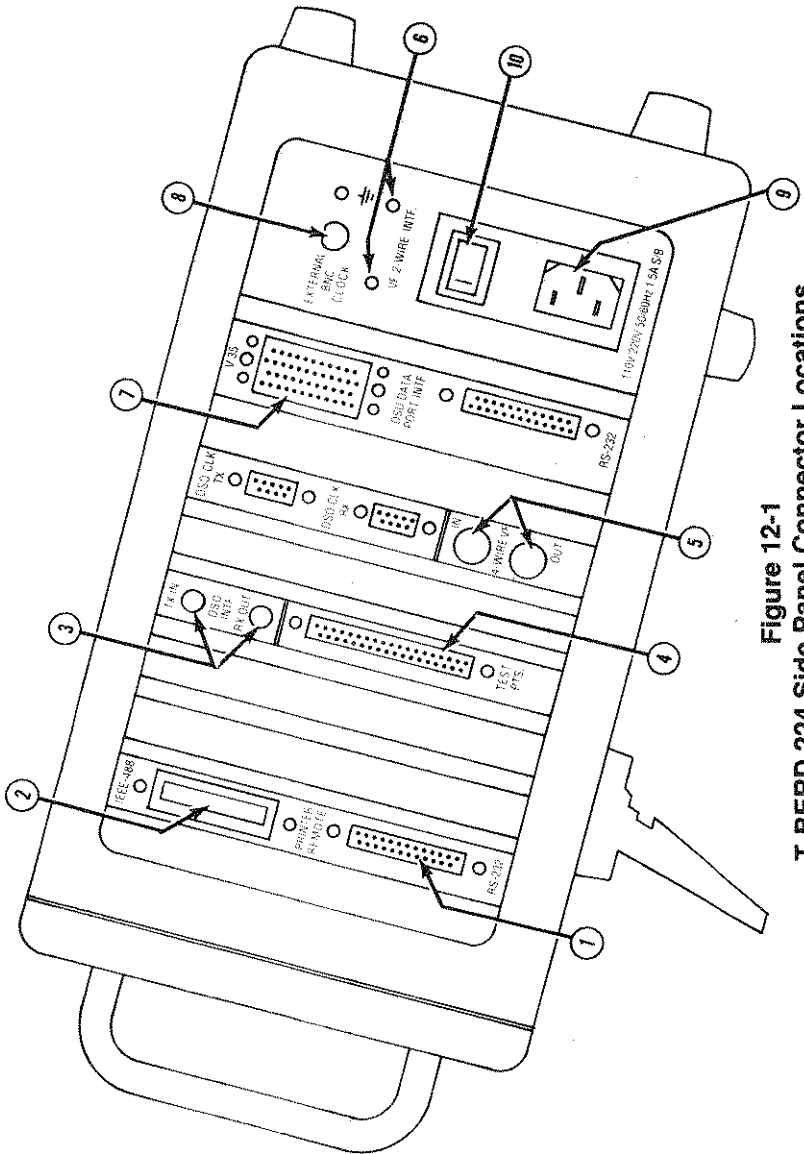
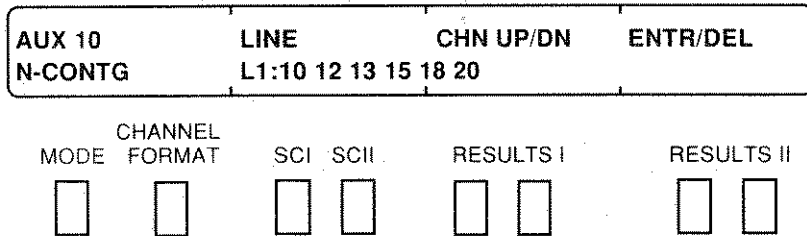

Figure 12-1
T-BERD 224 Side Panel Connector Locations

12.5 AUXILIARY FUNCTIONS

This section lists the auxiliary functions added by the DSU-DP Option and describes the use of each function, including an example of the auxiliary function display.

12.5.1 AUX 10 N-CONTG — Non-Contiguous Channel Drop and Insert



AUX 10 N-CONTG allows the user to select which non-contiguous channels are to be tested from each line. The channel number range is 1-24. These channel numbers must be entered in increasing order only. The auxiliary function is controlled by the following switches:

SCII switch — Press the **SCII** switch to select the T1 LINE input to be configured for non-contiguous channels, L1 (LINE 1) or L2 (LINE 2).

NOTE: The same number of channels must be selected from line 1 as are selected from line 2 before exiting the auxiliary function. If not, the selected configuration is not saved and the message “UNEQUAL # OF CHANNELS, CONFIGURATION NOT SAVED” is displayed. Note that the newly selected and saved channels are enabled when the user scrolls to another auxiliary function or exits the AUX mode.

RESULTS I Category switch — Press the **RESULTS I Category** switch to select the channel number above the flashing cursor. Pressing up increments the channel number and pressing down decrements the channel number.

RESULTS II Results switch — Press the **RESULTS II Results** switch UP arrow to enter the displayed channel selection as part of the non-contiguous bandwidth. The channel number is then set and the cursor will automatically move one position to the right to provide another channel number selection. Press the **RESULTS II Results** switch DOWN arrow to delete the displayed channel number above the cursor. The cursor will automatically move one position to the left.

If the **SCII** switch is set to NON CONTIG, changing this Auxiliary Function causes a test restart.

12.5.2 AUX 11 ANL CHA — DSU-DP Analysis Channel

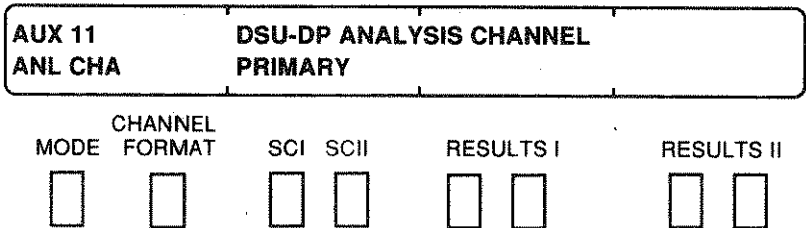

AUX 11 ANL CHA determines which DDS channel (PRIMARY or SECONDARY) is to be dropped and inserted. PRIMARY, the default channel, provides test access to the PRIMARY channel data of the DS0A or DS0B channel selected in the CHANNEL FORMAT, SOURCE CONFIGURATION II, and CHANNEL displays. SECONDARY provides test access to the secondary channel data of the DS0A or DS0B channel selected in the CHANNEL FORMAT, SOURCE CONFIGURATION II, and CHANNEL displays. The auxiliary function is controlled by the following switches:

SCII switch — Press the **SCII** switch to select the PRIMARY or SECONDARY DDS channel.

NOTE: If the **CHANNEL FORMAT** switch is set to DS0A2.4, DS0A4.8, DS0A9.6, DS019.2, DS0A56, DS0B2.4, DS0B4.8, or DS0B9.6, changing this auxiliary function causes a test restart.

SECTION 12

12.5.3 AUX 12 ERR COR — DS0A Error Correction

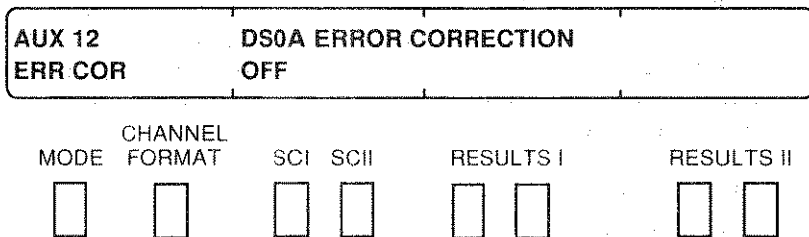

AUX 12 ERR COR determines whether or not majority-rule error correction is performed on subrate DS0A data before it is output to an external test set connected to the side panel DSU-DP Option interfaces. Error correction is performed on DS0A-formatted data rates of 9.6 kb/s, 4.8 kb/s, and 2.4 kb/s by the majority vote method. ON provides test access to subrate DS0A data which has been error corrected. OFF, the default selection, provides test access to subrate DS0A data which has been selected from every fifth, tenth, or twentieth frame, depending on the DS0A rate. The auxiliary function is controlled by the following switches:

SCII switch — Press the **SCII** switch to choose whether DS0A error correction is ON or OFF.

12.6 TESTING

12.6.1 Cabling To External Test Set/DTE

For simplex drop and insert, use a straight-through, male-to-male cable to connect an external test set to a DSU-DP Option interface. This set-up is useful when monitoring a circuit in one transmission direction or when performing an out-of-service channel test. Data transmitted toward the external test set is selected using the **DROP** switch, which is set to LINE 1 or LINE 2. Data received from the external test set is inserted into the T1 circuit designated by the **INSERT** switch: LINE 1 or LINE 2.

Tables 12-3 through 12-8 provide detailed pinout assignments for cable connections to an external test set/DTE. Table 12-9 describes the data input/output according to various **DROP** and **INSERT** settings.

Table 12-3
RS-232 Male-to-Female Adaptor Cable

Signal Name	To 224	To DTE	Signal Name
	Male	Female	
PROT. GND	1	1	PROT. GND
TX DATA	2	2	TX DATA
RX DATA	3	3	RX DATA
RTS	4	4	RTS
CTS	5	5	CTS
DSR	6	6	DSR
SIG. GND	7	7	SIG. GND
RLSD	8	8	RLSD
+12V	9	9	+12V
-12V	10	10	-12V
DCE TX CLK	15	15	DCE TX CLK
DCE RX CLK	17	17	DCE RX CLK

Table 12-4
RS-232 Male-to-Male Adaptor Cable

Signal Name	To 224	To DTE	Signal Name
	Male	Male	
PROT. GND	1	1	PROT. GND
DSR	6	20	DTR
SIG. GND	7	7	SIG. GND
+12V	9	9	+12V
-12V	10	10	-12V
SEC. RX DATA	16	2	TX DATA
SEC. RX CLK	18	24	TX CLK
RLSD	8	4	RTS

**Table 12-5
V.35 Male-to-Female Adaptor Cable**

Signal Name	To 224	To DTE	Signal Name
	Male	Female	
PROT.GND	A	A	PROT. GND
SIG. GND	B	B	SIG. GND
RTS	C	C	RTS
CTS	D	D	CTS
DSR	E	E	DSR
RLSD	F	F	RLSD
TX DATA (A)	P	P	TS DATA (A)
RX DATA (A)	R	R	RX DATA (A)
TX DATA (B)	S	S	TS DATA (B)
RX DATA (B)	T	T	RX DATA (B)
SCR (A)	V	V	SCR (A)
SCR (B)	X	X	SCR (B)
SCT (A)	Y	Y	SCT (A)
SCT (B)	AA	AA	SCT (B)

**Table 12-6
V.35 Male-to-Male Adaptor Cable**

Signal Name	To 224	To DTE	Signal Name
	Male	Male	
PROT.GND	A	A	PROT. GND
SIG. GND	B	B	SIG. GND
DSR	E	H	DTR
RLSD	F	C	RTS
SEC. RX DATA (A)	DD	P	TX DATA (A)
SEC. RX DATA (B)	FF	S	TX DATA (B)
SEC. SCR (A)	HH	U	SCTE (A)
SEC. SCR (B)	KK	W	SCTE (B)

Table 12-7
RS-449 Male-to-Female Adaptor Cable

Signal Name	To 224	To DTE	Signal Name
	Male	Female	
PROT. GND	1	1	PROT. GND
TX DATA (A)	4	4	TX DATA (A)
TX CLK (A)	5	5	TX CLK (A)
RX DATA (A)	6	6	RX DATA (A)
RTS (A)	7	7	RTS (A)
RX CLK (A)	8	8	RX CLK (A)
CTS (A)	9	9	CTS (A)
DM (A)	11	11	DM (A)
RR (A)	13	13	RR (A)
SIG. GND	19	19	SIG. GND
RX COMMON	20	20	RX COMMON
TX DATA (B)	22	22	TX DATA (B)
TX CLK (B)	23	23	TX CLK (B)
RX DATA (B)	24	24	RX DATA (B)
RTS (B)	25	25	RTS (B)
RX CLK (B)	26	26	RX CLK (B)
CTS (B)	27	27	CTS (B)
DM (B)	29	29	DM (B)
RR (B)	31	31	RLSD (B)
TX COMMON	37	37	TX COMMON

Table 12-8
RS-449 Male-to-Male Adaptor Cable

Signal Name	To 224	To DTE	Signal Name
	Male	Male	
PROT. GND	1	1	PROT. GND
SEC. RX DATA (A)	3	4	TX DATA (A)
DM (A)	11	12	DTR (A)
RR (A)	13	7	RTS (A)
SEC. RX CLK (A)	16	17	TERM.TIM (A)
SIG. GND	19	19	SIG. GND
SEC. RX DATA (B)	21	22	TX DATA (B)
DM (B)	29	30	DTR (B)
RR (B)	31	25	RTS (B)
SEC. RX CLK (B)	33	35	TERM TIM (B)
TX COMMON	37	37	TX COMMON

Table 12-9
“Y” Adaptor Cable

	To DTE Connector (B)	To DCE Connector (C)
DROP L1	Receive output from L1	Receive output from L2
DROP L2	Receive output from L2	Receive output from L2
DROP BOTH	Receive output from L1	Receive output from L2

12.6.2 Transmitting Data

The DSU-DP Option interfaces are configured as DCE and provide transmit clocks synchronized to the T1 framing pattern. These clocks must be used by the data terminal equipment (DTE) as the timing source in generating data. Before a DSU-DP interface will accept data from the DTE, the following conditions must be met:

- The **SCI** switch must be set to DSU-DP.
- The **INSERT** switch must be set to LINE 1 or LINE 2.
- The T-BERD 224 must be synchronized to each T1 line input's framing pattern and for DS0B2.4, DS0B4.8, and DS0B9.6 each T1 input's subrate framing pattern.
- The RTS signaling lead from the DTE must be set high.

When these conditions are met, the T-BERD 224 will set the DSU-DP Option interface's CTS lead to true, indicating that the instrument is ready to accept data. Data from the external test set is inserted into the channel(s) designated by the **INSERT** and **CHANNEL** switches. If RTS is not set high, but the **INSERT** switch is still set to LINE 1 or LINE 2 (instead of NONE), then the interface defaults to inserting data from the RS-232 interface.

NOTE: At data rates greater than 64 kb/s, input is only accepted for the V.35 or RS-449 (422). The RS-232 is ignored.

12.6.3 Receiving Data

Data dropped from the selected channel(s) is simultaneously routed to both side-panel interfaces (RS-232/V.35 or RS-232/RS-449) along with the received clock if the following conditions are met:

- The **SCI** switch must be set to DSU-DP.
- The T-BERD 224 must be synchronized to each T1 line input's framing pattern and for DS0B2.4, DS0B4.8, and DS0B9.6 each T1 input's subrate framing pattern.

Data dropped to the DSU-DP Option interfaces may be from LINE 1, LINE 2, or both lines according to the setting of the **DROP** switch. For all data, the RLSD lead is true when all lines being used have frame synchronization.

12.6.4 Analyzing a Data Channel's Protocol

By bridging or monitoring a T1 circuit in both directions at a DSX-1 patch panel or CSU, the T-BERD 224 enables users to observe a channel's protocol in both directions simultaneously. Analyzing a data channel's protocol is useful when:

- Troubleshooting dropouts which are occurring somewhere within the network.
- Measuring throughput.
- Verifying ACK/NAK receptions in both transmission directions.

Figure 12-2 illustrates how to connect the T-BERD 224 to the circuit to analyze a data channel's protocol. Perform the procedure in Table 12-10 to set up, test, and collect the results for analyzing a data channel's protocol.

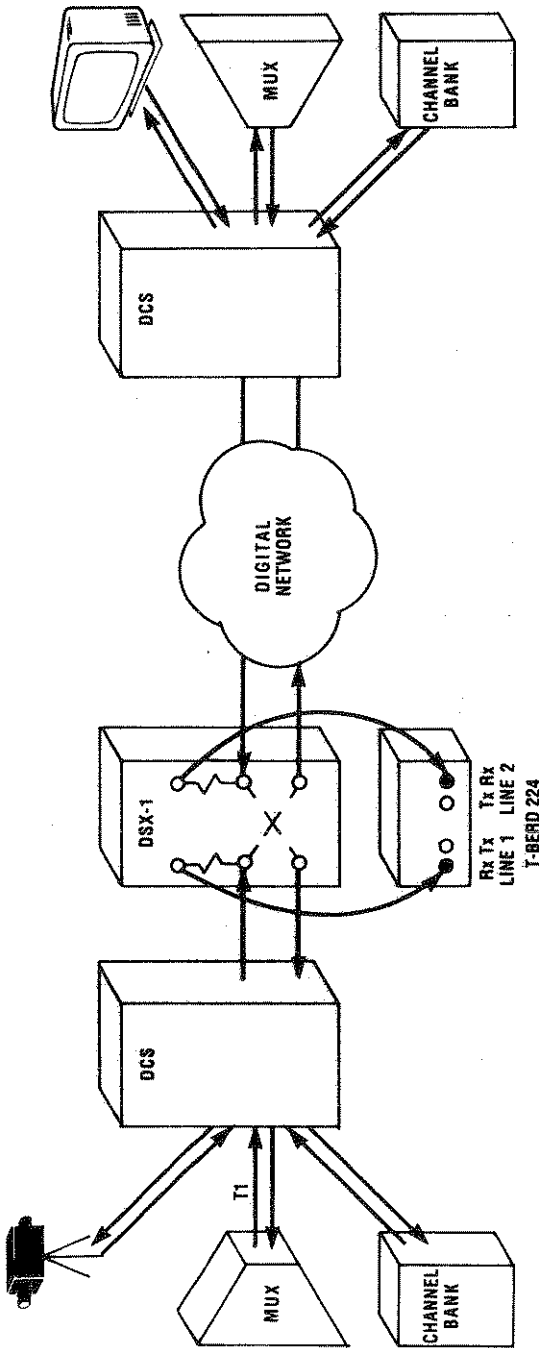

Figure 12-2
Equipment Connections for Analyzing a Data Channel's Protocol

Table 12-10
Test Procedure for Analyzing a Data Channel's Protocol

Step	Controls/Indicators/ Connections	Activity
1.	T1 Circuit Connections	<p>Perform the procedure in Section 4.2.1, T1 Circuit Monitoring, to connect the T-BERD 224 to the T1 circuit for testing with the following parameters:</p> <ul style="list-style-type: none"> (a) MODE switch is set to desired T1 format or AUTO. (b) CHANNEL FORMAT switch is set to DS0A, DS0B, fractional T1, or datalink format for channel under test. (c) SCI switch is set to DSU-DP. (d) SCII switch is set to appropriate customer channel for DS0B or number of channels for fractional T1 data. <p>NOTE: For DS0A or DS0B Data, use AUX 11 ANL CHA to access PRIMARY or SECONDARY channel.</p>
2.	DSU-DP Option interfaces	<p>Connect an external protocol analyzer or data scope test set to one of the T-BERD 224 DSU-DP Option interfaces. To observe protocol in both directions simultaneously, connect the T-BERD 224 SECONDARY CLOCK and DATA pins to the appropriate pins on the protocol analyzer.</p>
3.	RESTART switch	Press to begin the test.

Table 12-10
Test Procedure for Analyzing a Data Channel's Protocol
(Continued)

Step	Controls/Indicators/ Connections	Activity
4.	LOCAL STATUS LEDs	Verify that no red LEDs are illuminated, except B8ZS history, which may illuminate if B8ZS encoding is present.
5.	RESULTS I Category switch	Select the SUMMARY Category.
6.	RESULTS I Results switch	The RESULTS I display should read RESULTS OK. If not, scroll through the SUMMARY Category results to identify any out-of-specification results.
7.	External Test Set	Configure the protocol analyzer or data scope to the appropriate data rate, parity, protocol, etc.

Refer to the following items to interpret the test results:

- If frame errors, CRC errors, and BPVs are detected, it is likely that the errors are being introduced by the near-end T1 span.
- If frame errors or CRC errors are detected, but the BPV count remains at 0, it is likely that errors are not being introduced at the near-end T1 span and further sectionalization is required.
- For interpretation of the data protocols throughput, response time, etc., refer to the external test set's manual or application note.

12.6.5 Replacing a Fractional T1 DSU/CSU With The T-BERD 224

This type of test is most often performed on multiple T1 channels carrying data or video traffic within the T1 network. Replacing a fractional T1 DSU/CSU with the T-BERD 224 lets users:

- Verify DSU/CSU operation.
- Locate misconfigured transmission equipment by testing fractional T1 circuits before customer equipment is connected.
- Verify reported fault conditions.
- Determine location of error sources.

By placing the T-BERD 224 in the span so that the T1 circuit passes through the unit, users can overwrite any channel's contents without disrupting the remaining channels. While performing an out-of-service test on a specific channel, the T-BERD 224 is analyzing both T1 inputs for bipolar violations, frame errors, and signal impairments.

Figure 12-3 illustrates how the T-BERD 224 is connected to the T1 circuit in place of a fractional T1 DSU/CSU. Perform the procedure in Table 12-11 to set up, test, and collect the results when testing point-to-point fractional T1 circuits.

Refer to the following items to interpret the test results:

- If frame errors, CRC errors, and BPVs are detected, it is likely that the errors are being introduced by the near-end repeatered span.
- If frame errors or CRC errors are detected, but the BPV count remains at 0, it is likely that errors are not being introduced at the near-end repeatered span and further sectionalization is required.
- If the CSU was looping the simplex current, verify the Central Office is providing 60 mA of current.

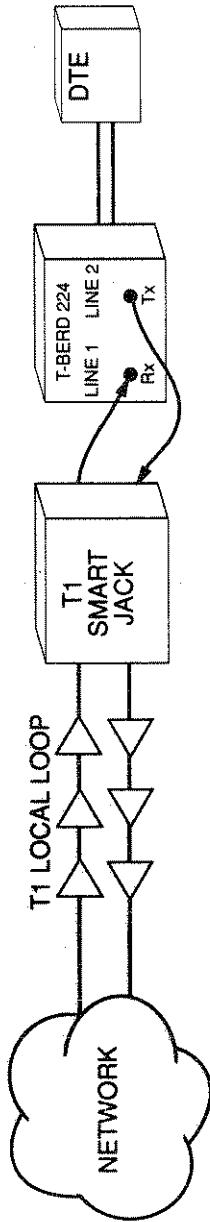

Figure 12-3
Replacing Fractional T1 DSU/CSU

Table 12-11
Test Procedure for Replacing Fractional T1 DSU/CSU
With The T-BERD 224

Step	Controls/Indicators/ Connections	Activity
1.	T1 Circuit Connections	<p>Perform the procedure in Section 4.2.3, T1 Circuit Termination, to connect the T-BERD 224 for terminating the T1 circuit with the following parameters:</p> <ul style="list-style-type: none"> (a) MODE switch is set to desired T1 format or AUTO. (b) CHANNEL FORMAT switch is set to either 64xN or 56xN depending on the fractional T1 service under test. (c) SCI switch is set to DSU-DP. (d) SCII switch is set to number of channels for fractional T1 data or NON CONTIG. For NON CONTIG, set DS0 channels with AUX 10 N-CONTG. <p>NOTE: If the channel numbers are unknown, use the byte decoder (CHANNEL category, n80 RCV BYT) to determine which channels contain data and which contain an idle signal.</p>
2.	LINE 1 and LINE 2 CHANNEL switches	Select the first DS0 channel of the fractional T1 circuit.
3.	TEST switch	Set to CONT or TIMED, as required.
4.	RESTART switch	Press to begin the test.

Table 12-11
Test Procedure for Replacing Fractional T1 DSU/CSU
With The T-BERD 224 (Continued)

Step	Controls/Indicators/ Connections	Activity
5.	External test set	Connect the DTE to the T-BERD 224 DSU-DP Option interface, as shown in Figure 12-5.
6.	Power ON switch	Apply power to the DTE and configure it for the appropriate data rate and test pattern.
7.	RESULTS verification	Verify the DTE equipment is synchronized to the network.

12.7 ERROR MESSAGES

Most error messages contain the prefix ERROR and are terminated by a CR, LF, or CRLF sequence, as selected by AUX 08 RS 232 (see Section 2, Instrument Description). For a detailed discussion of error messages see Section 6.4, Error Messages. The following is a list of possible DSU-DP Option error messages and a brief explanation of what may have caused the error.

ERROR: *Non-contiguous channel numbers must be in ascending order*
The non-contiguous channel numbers were not entered in ascending order.

ERROR: *Non-contiguous channel numbers must be the same length*
The number of non-contiguous channel numbers were not the same for both LINE 1 and LINE 2.

ERROR: *Channel number is out of range*
The channel number is out of range for the current setup (e.g., channel 12 entered when CHAN 1-10 is selected).

12.8 REMOTE CONTROL COMMANDS

Table 12-12 lists the additional remote control commands that enable the DSU-DP Option to be controlled from a remote device. The remote control commands added or affected by the DSU-DP Option are described in the following sections.

Table 12-12
DSU-DP Option Remote Control Commands

Command	Command Name
DS0 ERR COR	Set DS0A error correction ON or OFF
DSU ANA CHA	Select DSU Analysis Channel
NON CON	Select the non-contiguous channels for LINE 1 and for LINE 2

SECTION 12**CHA FOR****CHA FOR****Channel Format**

CHA FOR? :Displays the current channel format
CHA FOR (channel) :Sets the channel format

CHA FOR sets the current channel format for the T-BERD 224. The channel format selections enabled by the DSU-DP are:

DS0A2.4 :DS0A formatted DDS data at 2.4 kb/s
DS0A4.8 :DS0A formatted DDS data at 4.8 kb/s
DS0A9.6 :DS0A formatted DDS data at 9.6 kb/s
DS0A19.2 :DS0A formatted DDS data at 19.2 kb/s
DS0A56 :DS0A formatted DDS data at 56 kb/s
DS064 :Clear channel data at 64 kb/s
DS0B2.4 :DS0B formatted DDS data at 2.4 kb/s
DS0B4.8 :DS0B formatted DDS data at 4.8 kb/s
DS0B9.6 :DS0B formatted DDS data at 9.6 kb/s
56xN :56xN Fractional T1 data
64xN :64xN Fractional T1 data
DAT LIN :ESF 4 kb/s data link or ESFz* 2 kb/s data link
formatted data

*Requires ZBTISI Framing Option

NOTE: Changing the channel format causes a test restart and changes the current front panel configuration to the previous configuration of the selected channel format. A warning is printed indicating the new setup (see EXAMPLE).

EXAMPLE:

```
> CHA FOR? :display the current channel format
  CHAnnel FORmat DS0A2.4
> CHA FOR DS0A19.2 :select DS0A19.2 as the channel format
  WARNING: New Setup:
  MODe T1D4
  CHAnnel FORmat DS0A19.2
  SOURce 1 DSU-DP
  SOURce 2
```

DS0 ERR COR

DS0 ERR COR

DS0A Error Correction

DS0 ERR COR? :Displays the current status of the DS0A error correction

DS0 ERR COR [ON|OFF] :Sets the DS0A error correction

DS0 ERR COR allows you to determine if majority-rule error correction is performed on the substrate DS0A data. **DS0 ERR COR ON** causes access to data verified using majority-rule error correction. **DS0 ERR COR OFF** disables majority rule correction of errors.

This command is identical to AUX 12 ERR COR.

EXAMPLE:

> **DS0 ERR COR?** :display the current DS0A error correction status

DS0a ERRor CORrection OFF

> **DS0 ERR COR ON** :sets the DS0A error correction to ON

>

SECTION 12

DSU ANA CHA

DSU ANA CHA

DSU Analysis Channel

DSU ANA CHA? :Displays the current DSU analysis channel

DSU ANA CHA [PRI|SEC] :Select the channel for analysis

DSU ANA CHA selects or returns the current DDS channel analyzed for performance results. When you select **PRI** the primary DS0A or DS0B channel is selected for analysis; when you select **SEC** the secondary DS0A or DS0B channel is selected for analysis.

Modifying this command causes a test restart if **CHANNEL FORMAT** is set to DS0A or DS0B.

EXAMPLE:

> **DSU ANA CHA?** :displays the current analysis channel
DSU ANAlysis CHAnnel PRImary

> **DSU ANA CHA SEC** :sets the analysis channel to secondary

>

NON CON

NON CON

Non-Contiguous Channel Selection

NON CON? :Displays current non-contiguous channel selection

NON CON L1 [NN] L2 [NN] :Selects the channel numbers (NN) for LINE 1 and LINE 2

NON CON allows the user to select which non-contiguous channel numbers are to be tested from each line. The channel numbers range from 1 to 24. The number of channels must be the same for each line and they must be in ascending order.

Modifying this command causes a test restart if **SCII** switch is set to **NON CONTIG**.

This command is identical to **AUX 10 N-CONTG**.

EXAMPLE:

> NON CON? :displays the non-contiguous channels selected for LINE 1 and LINE 2

LINE1: 1,2,3,4,5

LINE2: 3,4,5,6,7

> NON CON L1 4,5,6,7,8 L2 5,6,7,8,9 :selects the non-contiguous channels for LINE 1 (4, 5, 6, 7, and 8) and for LINE 2 (5, 6, 7, 8, and 9)

>

SECTION 12**SOU 1****SOU 1****Source Configuration I**

SOU 1? :Displays the current selection for the **SCI** switch

SOU 1 (parameter) :Selects the setting for the **SCI** switch

SOU 1 selects or returns the drop and insert source which is to be used when analyzing the selected channel(s).

The following parameter is available for the DSU-DP Option:

DSU-DP :Selects DSU-DP configuration

Modifying this command causes a test restart and may change the current setup.

EXAMPLE:

> **SOU 1?** :displays current **SCI** switch selection

SOURce 1 1004

> **SOU 1 DSU-DP** :select DSU-DP as the new source configuration

WARNING: New Setup:

MODe T1D4

CHAnnel FORmat DS0A19.2

SOURce 1 DSU-DP

SOURce 2

>

SOU 2

SOU 2

Source Configuration II

- SOU 2?** :Displays the current status for the **SCII** switch selection.
- SOU 2 (parameter)** :Selects the setting for the **SCII** switch

SOU 2 augments the **SCI** switch selection. Selects or returns the drop and insert source which is to be used when analyzing the selected channel(s).

The following parameters are available for the DSU-DP Option:

- CHAN [x]** :displays the subrate channel number (where x = 1 to 20, 1 to 10, or 1 to 5) of a DS0B-formatted channel
- N = [x]** :selects the number of channels (where x = 1 to 24) of a Fractional T1 signal
- NON CON** :selects non-contiguous channels for a Fractional T1 signal (The non-contiguous channels are defined by AUX 10 N-CONTG)

Modifying this command causes a test restart.

EXAMPLE:

- > **SOU 2?** :display the current **SCII** switch selection
 SOURCE 2 CHANNEL 5
- > **SOU 2 CHAN 8** :change the channel number to 8
- >

12.9 SPECIFICATIONS

The following specifications only relate to features and capabilities of the DSU-DP Option.

12.9.1 DSU-DP Option Interfaces

• RS-232:	Connector —	25-pin, D-type, female.
	Connector Pin Assignments—	See Table 12-14.
	Data Rates	
	Primary —	2.4, 4.8, 9.6, 19.2, 56*, or 64* kb/s.
	Secondary —	0.133, 0.266, 0.533, 1.066, or 2.667 kb/s.
	Data Polarity	
	Mark (binary 1) —	-3 V to -25 V.
	Space (binary 0) —	+3 V to +25 V.
	Drivers (Output levels into 3000-ohm load)	
	Low level —	-10 V \pm 1 V, typical.
	High level —	+10 V \pm 1 V, typical.
	Slew Rates (Into 7000-ohm resistive load)	
	Clock and data —	6 V/microsecond, typical.
	Signaling —	6 V/microsecond, typical.
	Maximum Short-Circuit	
	Current —	+12 mA.
	Receivers	
	Input impedance —	3000 to 7000 ohms.
	Input threshold —	+2 V and -1 V.
	Maximum Input	
	Voltage —	\pm 25 V.

* These data rates exceed the data rate limitations recommended in RS-232 and V.24. However, the RS-232 connector can still be used but with result of increased bias distortion and clock data skew.

Table 12-13
DSU-DP RS-232 Connector Pin Assignments

Pin	Signal Name	Status
1	Protective Ground	Chassis Ground
2	Transmitted Data	Input
3	Received Data	Output
4	Request to Send	Input
5	Clear to Send	Output
6	Data Set Ready	Output
7	Signal Ground	Signal Ground
8	Received Line Signal Detect	Output
9	+12 V	Output
10	-12 V	Output
15	Transmit Signal Element Timing	Output
16	Secondary Received Data	Output
17	Receiver Signal Element Timing	Output
18	Secondary Received Clock	Output*

*Non-standard pin configuration.

- V.35: Connector — 34-pin, female.
Connector Pin See Table 12-15.
Assignments —

- Data Rates
- Primary — 2.4, 4.8, 9.6, 19.2, 56, or 64 kb/s.
- Secondary — 0.133, 0.266, 0.533, 1.066, or 2.666 kb/s.
- 56xN — 56 kb/s to 1.344 Mb/s in 56 kb/s increments.
- 64xN — 64 kb/s to 1.536 kb/s in 64 kb/s increments.

Table 12-14
DSU-DP V.35 Connector Pin Assignments

Pin	Signal Designation	Signal Status
A	Protective ground	Chassis Ground
B	Signal ground	Signal Ground
C	Request to send	In
D	Clear to send	Out
E	Data set ready	Out
F	Receive signal detector	Out
P	Send data (A)	In
R	Receive data (A)	Out
S	Send data (B)	In
T	Receive data (B)	Out
V	Serial clock receive (A)	Out
X	Serial clock receive (B)	Out
Y	Serial clock transmit (A)	Out
a	Serial clock transmit (B)	Out
d	Secondary receive data (A)*	Out
f	Secondary receive data (B)*	Out
h	Secondary serial clock receive (A)*	Out
k	Secondary serial clock receive (B)*	Out

*Non-standard pin configuration.

Polarity

Clock Polarity —

OFF - "A" lead negative, with respect to the "B" lead. ON - "A" lead positive, with respect to the "B" lead.

Data Polarity —

Mark (binary 1) "A" lead negative, with respect to the "B" lead. Space (binary 0) "A" lead positive, with respect to the "B" lead.

Signaling Polarity —	On - Greater than +3 V, Off - Open, or less than -3 V.
Data and Clock Drivers	
Source impedance —	100 ohms \pm 50 ohms.
Resistance from short-circuited terminals to ground —	150 ohms \pm 15 ohms.
Rise Time —	Less than 40 nanoseconds, into a 100-ohm resistive load.
Maximum short- circuit current —	Less than 100 mA.
Signal Swing —	\pm 0.55 V, into 100 ohms.
Data and Clock Receivers	
Input impedance —	100 ohms \pm 10 ohms.
Resistance from short-circuited terminals to ground —	150 ohms \pm 15 ohms.
Input hysteresis —	70 mV, typical.
Signaling Drivers	
Slew rate —	30 V/microsecond into 7000-ohm resistive load, typical.
Rise and Fall Time —	0.2 microseconds into 7000 ohm load.
Short Circuit Current —	\pm 45 mA.
Generator Impedance —	300 ohms, typically.
Signaling Receivers	
Input impedance —	3000 to 7000 ohms.
Maximum Input Range —	\pm 25 V.
• RS-449: Connector —	37 pin, D-type, female.
Connector Pin Assignments —	See Table 12-16.
Impedance —	110 ohms, minimum.
Data Rates	
Primary —	2.4, 4.8, 9.6, 19.2, 56, or 64 kb/s.

Table 12-15
DSU-DP RS-449 Connector Pin Assignment

Pin No.	Signal Designation	Signal Status
1	Shield	Chassis Ground
3	Secondary receive data (A)	Out
4	Send data (A)	In
5	Send timing (A)	Out
6	Receive data (A)	Out
7	Request to send (A)	In
8	Receive timing (A)	Out
9	Clear to send (A)	Out
11	Data mode (A)	Out
13	Receiver ready (A)	Out
16	Secondary receive data (A)*	Out
19	Signal ground	Signal Ground
20	Receive common	Signal Ground
21	Secondary receive data (B)*	Out
22	Send data (B)	In
23	Send timing (B)	Out
24	Receive data (B)	Out
25	Request to send (B)	In
26	Receive timing (B)	Out
27	Clear to send (B)	Out
29	Data mode (B)	Out
31	Receiver ready (B)	Out
33	Secondary receive timing (B)*	Out
37	Send common	Signal Ground

*Non-standard pin configuration.

Secondary —	0.133, 0.266, 0.533, 1.066, or 2.666 kb/s.
56xN —	56 kb/s to 1.344 Mb/s in 56 kb/s increments.
64xN —	64 kb/s to 1.536 kb/s in 64 kb/s increments.

Polarity

Data Polarity —	Mark (binary 1) - "A" lead more negative than "B" lead. Space (binary 0) - "B" lead more negative than "A" lead.
Clock Polarity —	High (binary 1) - "A" lead more negative than "B" lead. Low (binary 0) - "B" lead more negative than "A" lead.
Signaling Polarity —	OFF - "A" lead more nega- tive than "B" lead. ON - "B" lead more negative than "A" lead.

Data, Clock, and Signal Drivers

Source Impedance —	65 ohms.
Short Circuit Current —	±150 mA.
Output Differential Swing —	2 V minimum differential input into a 100-ohm load.
Rise Time —	20 nanoseconds, maximum.

Data and Clock Receivers

Input Resistance —	120 ohms, ±10%.
Input Hysteresis —	200 mV.
Maximum Input Voltage —	±25 V.

SECTION 12

BIT ERROR RATE TEST OPTION

13.1 INTRODUCTION

In addition to the current T-BERD 224 capabilities, the full T1, fractional T1 (FT1), and Digital Data Service (DDS) Bit Error Rate Test Option (BERT Option) provides additional features, functionality, and capabilities for performing bit error rate testing on digital circuits. Unless otherwise indicated, the previous T-BERD 224 functions and capabilities still apply.

13.1.1 Standard Features

The BERT Option offers the following standard features and capabilities:

- Performs out-of-service bit error rate tests using selectable test patterns to qualify digital circuits.
- Enables T-BERD 224 to replace and emulate a DS1 CSU to test live data and test data.
- Measures simplex current.
- Measures round trip delay.
- Tests framed and unframed T1 circuits.
- Tests DS0A and DS0B formatted DDS circuits.
- Tests 64xN and 56xN FT1 circuits.
- Transmits and responds to fixed (CSU, FAC (smart jack), and ESF datalink) and programmable T1 loop codes.
- Transmits alternating and latching DDS loop codes.
- Inserts logic, BPV, and frame errors (single, burst, or continuous) which enables the T-BERD 224 to stress T1 line protection switching.

SECTION 13

- Beeps when errored seconds occur (when n01 ASYN ES or n00 BIT ERR results are displayed), loss of pattern synchronization occurs, or completion of a timed test when the BER result is displayed.
- Supported through front panel and remote control operation.

13.1.2 Optional Features

Additional capabilities are provided when the following options are installed.

DSU-DP Option (Model 41441) — This option adds an EIA RS-232-C and either an EIA RS-449 or CCITT V.35 drop and insert interface for external testing of unformatted FT1, DS0A, DS0B, and ESF and ESFz datalink signals. Refer to Section 12, DSU-DP Option, for additional information.

ZBTSI Framing Option (Model 11425) — This option allows the T-BERD 224 to test and analyze T1 ESF (Extended Superframe) circuits that use ZBTSI encoding. Refer to Section 11, ZBTSI Framing Option, for additional information.

VF Option (Model 41502) — This option enables the T-BERD 224 to perform out-of-service voice frequency (VF) tests that provide measurements of voice-grade noise (C-Message and C-Notch noise), signal-to-noise ratio (S/N), data-grade noise (3 kHz Flat and 3 kHz Notch noise), return loss values (ERL, SRL-HI, and SRL-LO), peak-to-average ratio value (P/AR), DC-offset, and VF frequency and level. Refer to Section 14, VF Option, for a full description of the VF Option.

Enhanced ESF/SLC-96 Option (Model 11704) — This option enables the T-BERD 224 to monitor and transmit T1.403 performance report messages (PRMs) on ESF and ESFz framed circuits; monitor major, minor, power, and miscellaneous alarms; detect protection switches and maintenance activity on SLC-96 framed circuits; and send major, minor, and power alarms, as well as perform far-end loops on SLC-96 framed circuits. Refer to Section 15, Enhanced ESF and SLC-96 Option, for additional information.

For additional information on other options, refer to Section 9, Options and Accessories.

13.2 FUNCTIONAL DESCRIPTION

The BERT Option provides test patterns that can be used to test the full T1 span and individual channels for bit errors. Test results identify bit errors, bit error rates, synchronous and asynchronous errored seconds, and error-free seconds. The test patterns are selected through the **SOURCE CONFIGURATION I (SCI)** switch. The test pattern is inserted when the **INSERT** switch is set to either **LINE 1** or **LINE 2**. The T-BERD 224 can analyze the received test pattern one line at a time. For example, to analyze a looped circuit the test pattern is transmitted on **LINE 1** and received on **LINE 2**.

The BERT Option features the ability to send T1 and DDS loop codes by enabling the **LOOP UP** and **LOOP DOWN** switches. Different loop code types (T1, latching DDS, and alternating DDS) and equipment codes (e.g., CSU, ESF-LIN, DS0-DP, etc.) are selectable through an Auxiliary function. This feature enables the sectionalization of T1 and DDS span lines from a single test access point.

In addition to the T1 TLB and T1 LLB modes, the BERT Option enables the T-BERD 224 to automatically respond to T1 loop codes and establish an automatic line loopback (AUTO LLB), automatic ESF payload loopback (AUTO PLB), or FT1 line loopback (FT1 LLB). AUTO LLB is accomplished when the appropriate T1 loop code is selected, the AUX 18 AUT RES function is enabled, and the selected loop code is received. The received signal is retransmitted unaffected. The AUTO PLB configures the T-BERD 224 to retransmit the received data and regenerate the framing. The FT1 LLB indicates that the T-BERD 224 has received a FT1 loop code and looped the FT1 channel.

When the T-BERD 224 is synchronized to the test pattern, the PATTERN SYNC LED illuminates and bit error testing begins. Single, burst, and continuous logic and BPV errors can be inserted into the test pattern by pressing the **LOGIC** and **BPV ERROR INSERT** switches. The number and rate of bit errors and BPVs are controlled through an Auxiliary function (AUX 13 ERR RT). Single errors can be inserted by pressing the **ERROR INSERT** switch for less than 1 second when **SINGLE** has been selected from the Auxiliary function. A burst of errors can be inserted by pressing the **ERROR INSERT** switch for less than 1 second when the Auxiliary function is set for **BURST**. Continuous error insertion is possible by pressing the **ERROR INSERT** switch for more than 1 second. The error rate is controlled through the AUX 13 ERR RT function.

SECTION 13

Single and consecutive frame errors can also be inserted into any framing format by the **FRAME ERROR INSERT** switch and the AUX 14 FRM ERR function.

DDS primary and secondary channels can be tested individually without affecting the other DDS channels. Single DS0B customer channels within a 64 kb/s DS0 can be tested without affecting the other customer channel in the time slot.

13.3 CONTROLS AND INDICATORS

The following controls and indicators are affected by the BERT Option. Table 13-1 lists which switch configurations, selections, and Auxiliary functions are affected by the BERT Option. Unless otherwise indicated, the switch information described in Section 2, Instrument Description, also applies.

- **AUX** switch
- **MODE** switch
- **CHANNEL FORMAT** switch
- **SOURCE CONFIGURATION I (SCI)** switch
- **SOURCE CONFIGURATION II (SCII)** switch
- **RESULTS I** switches
- **RESULTS II** switches
- **LOOP CODES** switches
- **ERROR INSERT** switches
- **INSERT** switch

Table 13-1
BERT Option Switch Configurations

Switch/AUX Function	Configuration						
	TI-D1D, TI-D2, TI-D4, T1SLC96, T1-ESF, T1-ESFz (ZBTSI), T1 TLB, T1 LLB, T1 (Full T1), or AUTO	DS0B2.4	DS0B4.8	DS0B9.6	56 x N 64 x N ESF, ESFz, D4	FULL T1	
CHANNEL FORMAT Switch	DS0A2.4 DS0A4.8 DS0A9.6 DS019.2 DS0A56 DS064 DATLINK						
SCI	ALL ONES, ALL ZERO, USER, MIN/MAX, 2 ²³ -1, 2 ²⁰ -1, 2 ¹⁵ -1, 2 ¹⁵ -1, INV, QRSS, 3 IN 24, 1:7, 63, 511, 2047, DDS1, DDS2, DDS3, DDS4, AUTO						
SCII		CHAN 1 - 20	CHAN 1 - 10	CHAN 1 - 5	N = 1 - 24 NON CONTIG		
AUX 10 N-CONTG					X		
AUX 12 ERR COR	X						
AUX 13 ERR RT	X	X	X	X	X	X	X
AUX 14 FRM ERR	X	X	X	X	X	X	X
AUX 15 USER	X	X	X	X	X	X	X
AUX 16 PGM LP	X	X	X	X	X	X	X
AUX 17 LOOP CD	X	X	X	X	X	X	X
AUX 18 AUTO RES	X	X	X	X	X	X	X
AUX 19 DDS CHN	X	X	X	X	X	X	X

See Appendix E for fully optioned T-BERD 224.

SECTION 13

A typical BERT test front panel display configuration might appear as follows:

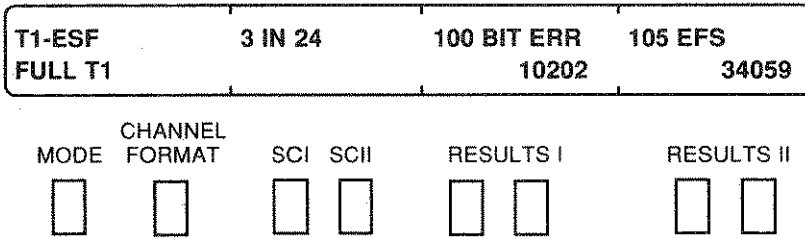

The display and switch selections are described in the following sections.

13.3.1 AUX Switch

In addition to the current Auxiliary functions, the following Auxiliary functions also appear when the **AUX** switch is pressed:

- AUX 10 N-CONTG — Non-Contiguous Channel Drop and Insert
- AUX 12 ERR COR — DS0A Error Correction
- AUX 13 ERR RT — Set BPV and Logic Error Insert Type, Burst Length, and Error Insertion Rate
- AUX 14 FRM ERR — Set Consecutive Frame Error Insertion
- AUX 15 USER — Set User Programmable Test Pattern
- AUX 16 PGM LP — Set User Programmable Loop Codes
- AUX 17 LOOP CD — Set Loop Code Type
- AUX 18 AUT RES — Set Automatic T1 Loop Code Response
- AUX 19 DDS CHN — Set DDS Analysis Channel and Pattern

Refer to Section 13.4, Auxiliary Functions, for a complete description of the Auxiliary functions.

13.3.2 MODE Switch

In addition to the current operating modes, the following operating modes also appear when the **MODE** switch is pressed:

T1 — **T1** mode configures the T-BERD 224 to transmit and receive unframed T1 data for testing unframed T1 circuits or T1 circuits with proprietary framing formats. When testing unformatted T1 lines, the following controls and indicators are disabled:

- **LINE 1/2 FRAME SYNC** LEDs (current and history)
- **LINE 1/2 YELLOW ALARM** LEDs (current and history)
- **FRAME ERROR INSERT** switch
- **YELLOW ALARM INSERT** switch
- **ABCD SIGNALING INSERT** switches and LEDs
- Signaling drop and insert test points

When the T1 mode is selected, the message “FULL T1” appears in the **CHANNEL FORMAT** display and all other channel formats are disabled.

AUTO — **AUTO** mode enables the T-BERD 224 to automatically recognize and configure itself to framed and unframed T1 signals. When an unframed signal is recognized, “t1” appears in the **MODE** display and “FULL T1” appears in the **CHANNEL FORMAT** display. The disabled controls and indicators described in the T1 mode are also disabled in the AUTO mode. This is an addition to the AUTO mode information discussed in Section 2.3.2, **MODE Switch** [2].

13.3.3 CHANNEL FORMAT Switch

The following additional channel formats are available when the **CHANNEL FORMAT** switch is pressed:

DS0A2.4 — Use when monitoring or testing DS0A-formatted DDS data at 2.4 kb/s. **PRIMARY** or **SECONDARY** channel data is analyzed

SECTION 13

using the AUX 19 DDS CHN function without disrupting the opposite channel. Users may choose to receive data sampled from repeated bytes or data processed using majority rule error correction through the AUX 12 ERR COR function.

DS0A4.8 — Use when monitoring or testing DS0A-formatted DDS data at 4.8 kb/s. PRIMARY or SECONDARY channel data is analyzed using the AUX 19 DDS CHN function without disrupting the opposite channel. Users may choose to receive data sampled from repeated bytes or data processed using majority rule error correction through the AUX 12 ERR COR function.

DS0A9.6 — Use when monitoring or testing DS0A-formatted DDS data at 9.6 kb/s. PRIMARY or SECONDARY channel data is analyzed using the AUX 19 DDS CHN function without disrupting the opposite channel. Users may choose to receive data sampled from repeated bytes or data processed using majority rule error correction through the AUX 12 ERR COR function.

DS019.2 — Use when monitoring or testing DS0A-formatted DDS data at 19.2 kb/s. When inserting test data into a T1 time slot, data is inserted in bytes 2 and 3, while bytes 1, 4, and 5 pass through unaffected. If no T1 signal is being received, the all ones pattern is placed in bytes 1, 4, and 5. PRIMARY or SECONDARY channel data is analyzed using the AUX 19 DDS CHN function without disrupting the opposite channel. When the receive signal is present, subrate frame synchronization must be acquired before the T-BERD 224 inserts test data.

DS0A56 — Use when monitoring or testing DS0A-formatted DDS data at 56 kb/s. PRIMARY or SECONDARY channel data is analyzed using the AUX 19 DDS CHN function without disrupting the opposite channel.

DS064 — Use when monitoring or testing clear channel 64 kb/s data.

DS0B2.4 — Use when monitoring or testing DS0B-formatted DDS data at 2.4 kb/s. Use the SCII switch to select one of 20 channels to be analyzed. PRIMARY or SECONDARY channel data may be tested without disrupting the opposite channel, or the remaining 19 channels, through AUX 19 DDS CHN. Note that subrate frame synchronization must be acquired before the T-BERD 224 can insert test data.

DS0B4.8 — Use when monitoring or testing DS0B-formatted DDS data at 4.8 kb/s. Use the **SCII** switch to select one of 10 channels to be analyzed. PRIMARY or SECONDARY channel data may be tested without disrupting the opposite channel, or the other 9 channels, through AUX 19 DDS CHN. Note that subrate frame synchronization must be acquired before the T-BERD 224 can insert test data.

DS0B9.6 — Use when monitoring or testing DS0B-formatted DDS data at 9.6 kb/s. Use the **SCII** switch to select one of 5 channels to be analyzed. PRIMARY or SECONDARY channel data may be tested without disrupting the opposite channel, or the other 4 channels, through AUX 19 DDS CHN. Note that subrate frame synchronization must be acquired before the T-BERD 224 can insert test data.

56 x N — Use when monitoring or testing 56xN FT1 circuits. This selection provides drop and insert access to Bits 1 to 7 of 1 to 24 contiguous DS0 channels or up to 23 non-contiguous DS0 channels. Non-contiguous channels are selected using the AUX 10 N-CONTG function. Note that this selection is only available when the **MODE** switch is set to T1-D4, T1-ESF, or T1-ESFz.

64 x N — Use when monitoring or testing 64xN FT1 circuits. This selection provides drop and insert access to Bits 1 to 8 of 1 to 24 contiguous DS0 channels or up to 23 non-contiguous DS0 channels. Non-contiguous channels are selected using the AUX 10 N-CONTG function. Note that this selection is only available when the **MODE** switch is set to T1-D4, T1-ESF, or T1-ESFz.

DATLINK — Use when monitoring or testing either the 4 kb/s ESF datalink or the 2 kb/s ESFz datalink (ESFz requires the ZBTSI Framing Option).

FULL T1 — The FULL T1 channel format enables the T-BERD 224 to test the full T1 signal when any unframed or framed T1 format is selected from the **MODE** switch.

13.3.4 SOURCE CONFIGURATION I Switch

When the operating mode is displayed and the **SCI** switch is pressed, the following test pattern selections are available:

- ALL ONES — All Ones Pattern

SECTION 13

- ALL ZERO — All Zeros Pattern
- USER — User Programmable Bit Pattern
- MIN/MAX — Minimum/Maximum Density Stress Pattern
- $2^{23}-1$ — 8,388,607-Bit Pseudorandom Pattern
- $2^{20}-1$ — 1,048,575-Bit Pseudorandom Pattern
- $2^{15}-1$ — 32,767-Bit Pseudorandom Pattern
- $2^{15}-1$ INV — Inverted 32,767-Bit Pseudorandom Pattern
- QRSS — Quasi-Random Signal Source Pattern
- 3 IN 24 — Three Ones In 24-Bits Pattern
- 1:7 — A One and Seven Zeros Pattern
- 63 — 63-Bit Pseudorandom Pattern
- 511 — 511-Bit Pseudorandom Pattern
- 2047 — 2047-Bit Pseudorandom Pattern
- DDS1 — DDS 1 Stress Pattern
- DDS2 — DDS 2 Stress Pattern
- DDS3 — DDS 3 Stress Pattern
- DDS4 — DDS 4 Stress Pattern
- AUTO — Automatic Pattern Search

Refer to Section 13.5, Test Patterns, for descriptions of the listed test patterns.

13.3.5 SOURCE CONFIGURATION II Switch

The SCII switch selections are only available with specific channel formats as indicated in Table 13-1.

When the **CHANNEL FORMAT** switch is set to either DS0B2.4, DS0B4.8, or DS0B9.6 the available **SCII** switch selections include:

- **CHAN = 1 to 5, 1 to 10, or 1 to 20** — This selection allows the user to choose one of the 5 (9.6 kb/s), 10 (4.8 kb/s), or 20 (2.4 kb/s) DDS DS0B channels to analyze. The remaining 4, 9, or 19 DDS DS0B channels are unaffected.

When the **CHANNEL FORMAT** switch is set to either 56 x N or 64 x N, the available **SCII** switch selections include:

- **N = 1 to 24** — This selection allows the user to choose the number of contiguous DS0 channels to analyze as a single FT1 channel bandwidth. The **LINE 1** and **LINE 2 CHANNEL** switches determine where the FT1 channel bandwidth begins.

NOTE: DS0s may “wrap around” the frame bit. For example, if N=2 and CHANNEL = 24, then channels 24 and 1 are analyzed.

- **NON CONTIG** — This selection allows the user to choose to analyze non-contiguous DS0 channels as a single non-contiguous FT1 channel bandwidth. When this selection appears in the display, press the **AUX** switch to immediately enter the AUX 10 N-CONTG function. Enter the necessary DS0 channel numbers for the non-contiguous FT1 channel bandwidth.

NOTE: The same number of channels must be set for LINE 1 and LINE 2 so that equal bandwidths are analyzed.

13.3.6 RESULTS I and II Switches

The following additional category results are available when the **RESULTS I** and **II** switches are pressed:

- The **SUMMARY** Category lists the **LOGIC** category bit error and pattern slip results and displays messages for B8ZS incompatibility and ones density violations.
- The **LOGIC** category results include bit error counts, asynchronous and synchronous errored seconds, bit error rates, errored and error-free seconds, percent error-free seconds, out-of-synchronization seconds, and pattern slip counts.

SECTION 13

- The **SIGNAL** category results include simplex current and round-trip delay measurements.
- The **CHANNEL** category results include DDS results identifying received DS0 control codes by name and binary format, DDS frame error counts, and percent of in-service secondary bits.
- The **TIME** category Alarm Second result (n71 ALA SEC) also counts ones density violations.

Refer to Section 13.6, Measurements, for a list of available results definitions.

13.3.7 **ERROR INSERT Switches**

The functions of the **ERROR INSERT** switches, **FRAME**, **BPV**, and **LOGIC**, described in Section 2.3.2, **ERROR INSERT** Switches [12], are expanded to include:

- Single BPV, logic, and/or frame error insertion
- Bursts of BPV and/or logic errors at specified lengths and insertion rates
- Continuous BPV, logic, and/or frame error insertion at specified insertion rates
- Consecutive frame error insertion

Auxiliary functions, **AUX 13 ERR RT** and **AUX 14 FRM ERR**, control the error insertion length and rate for logic, BPV, and frame errors (see Sections 13.4.3, **AUX 13 ERR RT** — Set BPV and Logic Error Insert Type, Burst Length, and Error Insertion Rate, and 13.4.4, **AUX 14 FRM ERR** — Set Frame Error Insertion). The **ERROR INSERT** switches are disabled in the T1 LLB and AUTO LLB modes and when the **INSERT** switch is set to NONE. The **ERROR INSERT** switches perform the following functions:

BPV ERROR INSERT switch — The switch inserts bipolar violations into the transmitted T1 signal (data and/or framing bits) on the selected T1 line (selected by **INSERT** switch). When the **AUX 13 ERR RT** function is set as indicated below, the **BPV ERROR INSERT** switch performs the following functions:

- **Single BPV error insertion** — If the AUX 13 ERR RT, ERROR TYPE, function is set to SINGLE, pressing the **BPV ERROR INSERT** switch for less than 1 second flashes the switch LED and inserts a single BPV into the T1 data stream.
- **Single burst of BPV errors** — If the AUX 13 ERR RT, ERROR TYPE, function is set to BURST, pressing the **BPV ERROR INSERT** switch for less than 1 second flashes the switch LED and inserts a single burst of BPVs into the T1 data stream. The burst length and insertion rate are set by the AUX 13 ERR RT function.
- **Continuous BPV error insertion** — If the **BPV ERROR INSERT** switch is pressed for more than 1 second, the switch LED illuminates and the T-BERD 224 inserts continuous BPVs into the T1 data stream at the selected insertion rate. With the **BPV ERROR INSERT** switch illuminated, pressing the switch again disables the BPV error insertion. The error insertion rate is set by the AUX 13 ERR RT function.

LOGIC ERROR INSERT switch — The switch inserts logic errors into the selected bandwidth of the T1 signal selected by the **CHANNEL FORMAT, INSERT,** and **CHANNEL** switches. This switch inserts logic errors:

- On any transmitted bits of the selected test pattern (see Section 13.3.4, **SOURCE CONFIGURATION I** Switch).
- In framed T1 modes with the FULL T1 channel format selected, unframed T1, and FT1 LLB errors are inserted on the entire bandwidth (data and framing bits). In all other channel formats, errors are only inserted on the selected test bandwidth.

When the AUX 13 ERR RT function is set as indicated below, the **LOGIC ERROR INSERT** switch performs the following functions:

- **Single logic error insertion** — If the AUX 13 ERR RT, ERROR TYPE, function is set to SINGLE, pressing the **LOGIC ERROR INSERT** switch for less than 1 second flashes the switch LED and inserts a single logic error into the selected test bandwidth.
- **Single burst of logic errors** — If the AUX 13 ERR RT, ERROR TYPE, function is set to BURST, pressing the **LOGIC**

ERROR INSERT switch for less than 1 second flashes the switch LED and inserts a single burst of logic errors into the selected test bandwidth. The burst length and insertion rate are set by the AUX 13 ERR RT function.

- **Continuous logic error insertion** — If the **LOGIC ERROR INSERT** switch is pressed for more than 1 second, the switch LED illuminates and the T-BERD 224 inserts continuous logic errors into the selected test bandwidth at the selected insertion rate. With the **LOGIC ERROR INSERT** switch illuminated, pressing the switch again disables the logic error insertion. The error insertion rate is set by the AUX 13 ERR RT function.

When testing DS0A channel formats, logic errors are only inserted in the DS0A bytes of the selected DS0A data rate (2.4, 4.8, or 9.6 kb/s). DS0B subrate frame synchronization is required before logic errors can be inserted in DS0B formatted channels. Frame synchronization is also required at the T1 level before logic errors can be inserted.

NOTE: Logic errors and BPVs are inserted without regard to B8ZS sequences. This may cause the same error multiplication (one inserted error causing multiple errors) that occurs on a repeated span.

FRAME ERROR INSERT switch — Inserts frame errors only on the transmitted framing bits (i.e., the F_i bits in T1-D1D, T1-D2, T1-D4, and T1SLC96 and Frame Pattern Sequence (FPS) bits in T1-ESF and T1-ESFz) of the selected T1 line (selected by **INSERT** switch). When the AUX 14 FRM ERR function is set as indicated below, the **FRAME ERROR INSERT** switch performs the following functions:

- **Single frame error insertion** — If the AUX 14 FRM ERR function is set to SINGLE, pressing the **FRAME ERROR INSERT** switch for less than 1 second flashes the switch LED and inserts a single frame error into the T1 signal framing bits.
- **Single burst of consecutive frame errors** — If the AUX 14 FRM ERR function is set for 2 to 6 CONSEC (consecutive) frame errors, pressing the **FRAME ERROR INSERT** switch for less than 1 second flashes the switch LED and inserts a single burst of consecutive frame errors into the T1 signal framing bits.

- **Continuous frame error insertion** — Pressing the **FRAME ERROR INSERT** switch for more than 1 second illuminates the switch LED and inserts continuous frame errors into the T1 signal framing bits. The number of inserted frames errors is controlled by the AUX 14 FRM ERR function. With the **FRAME ERROR INSERT** switch illuminated, pressing the switch again disables the frame error insertion.

When ZBTSI encoded data is received (ZBTSI Framing Option installed), the **FRAME ERROR INSERT** switch is disabled in the T1 LLB, AUTO LLB, and T1 modes. Refer to Section 13.3.2, **MODE** Switch, for additional information. The switch is also disabled when the **INSERT** switch is set to NONE. The switch is only functional after frame synchronization is achieved.

YELLOW ALARM INSERT switch — The switch functions the same as described in Section 2.3.2, **ERROR INSERT** Switches [12], except that the switch is not functional when the **MODE** switch is set to the unframed T1 mode.

13.3.8 LOOP CODES Switches

The **LOOP CODES** switches (**LOOP UP** and **LOOP DOWN** switches) transmit loop-up and loop-down codes from the T-BERD 224 to terminals that can respond to T1 in-band, out-of-band (ESF datalink), and DDS (latching and alternating) loop codes. The loop codes are used to establish an out-of-service loopback at specific terminals along the span. The transmitted loop code type is controlled through the AUX 17 LOOP CD function (see Section 13.4.7, AUX 17 LOOP CD — Set Loop Code Type). The **LOOP CODES** switches are *disabled* under the following conditions:

- When the T1 TLB and T1 LLB modes are selected.
- When the **INSERT** switch is set to NONE.
- When the CHANNEL number display is flashing during the 3 second insert wait time.
- When the T-BERD 224 is automatically responding to a loop code.

SECTION 13

- When the loop code type is set to DDS ALT in the AUX 17 LOOP CD function and the **SCI** switch is set to DSU-DP (if the DSU-DP Option is installed).
- When the current channel format is set to VF, VF THRU, or DS0.
- When T1 frame synchronization is not acquired.
- When DS0B and DS0A 19.2 kb/s subrate frame synchronization is not acquired.

The LOOP CODES switches perform the following functions:

LOOP UP switch — This pushbutton switch controls the transmission of the selected loop-up code. The default loop-up code is the in-band T1 CSU loop-up code, 10000. When the switch is pressed, the following occurs:

- The loop code is continuously transmitted until an appropriate response is detected at the T-BERD 224 receiver, a pre-determined timeout interval is exceeded, or the **LOOP UP** switch is pressed again.
- The transmitted loop code name appears in the SCI and SCII displays.
- The switch LED illuminates while transmitting the loop code.
- The in-band T1 and DDS loop-up codes override the selected data pattern. If an ESF out-of-band loop code is selected, the loop code is transmitted in the datalink channel and does not overwrite the test pattern.

LOOP DOWN switch — This pushbutton switch controls the transmission of the selected loop-down code. The default loop-down code is the in-band T1 CSU loop-down code, 100. When the switch is pressed, the following occurs:

- The loop code is continuously transmitted until the loop code is no longer detected at the T-BERD 224 receiver, a pre-determined timeout interval is exceeded, or the **LOOP DOWN** switch is pressed again.
- The transmitted loop code name appears in the SCI and SCII displays.

- The switch LED illuminates while transmitting the loop code.
- The in-band T1 and DDS loop-down codes override the selected data pattern. If an ESF out-of-band loop code is selected, the loop code is transmitted in the datalink channel and does not overwrite the test pattern.

13.3.9 Status and History Indicators

The LINE 1 or LINE 2 PATTERN SYNC LED illuminates when the received test pattern is recognized by the T-BERD 224 and pattern synchronization is achieved on the dropped line set by the **DROP** switch. Signal analysis only occurs on the dropped line. Pattern synchronization is dependent on a given number of consecutive error-free bits for the specific test pattern received. Pattern synchronization is declared on:

- Fixed patterns (ALL ONES, 1:7, 3 IN 24, programmable 3- to 24-bit pattern, ALL ZERO, DDS3, and DDS4) when 30 consecutive error-free bits are received.
- DDS1 and DDS2 patterns when 800 consecutive error-free bits are received.
- MIN/MAX pattern when 220 consecutive error-free bits are received.
- Pseudorandom patterns (QRSS, 63, 511, 2047, $2^{15}-1$, $2^{15}-1$ INV, $2^{20}-1$, and $2^{23}-1$) when $30 + n$ consecutive error-free bits for a pattern length of 2^n-1 (for the QRSS pattern, $n = 20$) are received.

Loss of pattern synchronization is declared when 250 or more bit errors are counted in 1000 data bits. Loss of pattern synchronization is indicated when the green current PATTERN SYNC LED is turned off and the red history PATTERN SYNC LED illuminates.

If the **DROP** switch is set to BOTH, only the LINE 1 LOCAL STATUS LEDs are functional.

13.3.10 CHANNEL Switches

When the **CHANNEL FORMAT** switch is set to either FULL T1, DATLINK, or $56 \times N$ or $64 \times N$ (the **SCII** switch is set to NON CONTIG),

SECTION 13

the **CHANNEL** switch number is displayed as “— —”. When in any other channel format, the **CHANNEL** switches determine the channels to be tested.

13.3.11 Audible Indicators

The T-BERD 224 provides an audible beep when one or more of the following conditions occur:

- When either of the LOGIC category results, n00 BIT ERR or n01 ASYN ES, is displayed and an errored second is detected.
- When loss of pattern synchronization occurs.
- When the LOGIC category result, n04 BER, is displayed and the timed test interval is complete.

The level of the beep is controlled by the **VOLUME** switch.

13.4 AUXILIARY FUNCTIONS

The following additional Auxiliary functions are available with the BERT Option. They are listed in sequential order under the **AUX** switch selections:

13.4.1 AUX 10 N-CONTG — Non-Contiguous Channel Drop and Insert

AUX 10 N-CONTG	LINE L1:10	CHN 12 13 15 18 20	UP↑/DN↓	E NTR↑/DEL↓
-------------------	---------------	-----------------------	---------	-------------

MODE	CHANNEL FORMAT	SCI	SCII	RESULTS I	RESULTS II
<input type="checkbox"/>	<input type="checkbox"/>	<input type="checkbox"/>	<input type="checkbox"/>	<input type="checkbox"/> <input type="checkbox"/>	<input type="checkbox"/> <input type="checkbox"/>

The AUX 10 N-CONTG function selects which DS0 channels is configured for an individual non-contiguous FT1 channel being tested on LINE 1 and LINE 2. This Auxiliary function only applies to the non-contiguous 56 x N

or 64 x N channel formats. If the **SCII** switch is set to NON CONTIG, changing this Auxiliary function causes a test restart. The Auxiliary function is controlled by the following switches:

SCII switch — Press the **SCII** switch to select L1 (LINE 1) or L2 (LINE 2) in the SCII display. This enables different DS0 channels to be selected for each direction.

RESULTS I Category switch — Press the **RESULTS I Category** switch to select the channel number above the flashing cursor. Pressing the switch up increments the channel number and pressing the switch down decrements the channel number. The channel number range is from 1 to 24. These channel numbers must be entered in increasing order only.

NOTE: The same number of channels must be selected for LINE 1 as are selected for LINE 2 before exiting the Auxiliary function. If not, the selected configuration is not saved and the message "UNEQUAL # OF CHANNELS, CONFIGURATION NOT SAVED" is displayed. The newly selected and saved channels are enabled when the user scrolls to another Auxiliary function or exits the Auxiliary functions.

RESULTS II Results switch — Press the **RESULTS II Results** switch UP arrow to enter the displayed channel number. The channel number is then set and the cursor automatically moves one position to the right to provide another channel number selection. Press the **RESULTS II Results** switch DOWN arrow to delete the displayed channel number above the cursor. The cursor automatically moves one position to the left when the channel number is deleted.

13.4.2 AUX 12 ERR COR — DS0A Error Correction

AUX 12 ERR COR		DS0A ERROR OFF		CORRECTION		
MODE	CHANNEL FORMAT	SCI	SCII	RESULTS I		RESULTS II
<input type="checkbox"/>	<input type="checkbox"/>	<input type="checkbox"/>	<input type="checkbox"/>	<input type="checkbox"/>	<input type="checkbox"/>	<input type="checkbox"/>

SECTION 13

The AUX 12 ERR COR function determines whether the DS0A majority-rule error correction method is performed on the subrate DS0A data. The DS0A error correction is performed on the DS0A-formatted data rates of 9.6 kb/s, 4.8 kb/s, and 2.4 kb/s. ON provides test access to the subrate DS0A data that is error corrected. OFF, the default selection, provides test access to the subrate DS0A data that is selected from every fifth, tenth, or twentieth frame, depending on the DS0A rate. The Auxiliary function is controlled by the following switch:

SCII switch — Press the **SCII** switch to choose whether DS0A error correction is ON or OFF.

13.4.3 AUX 13 ERR RT — Set BPV and Logic Error Insert Type, Burst Length, and Error Insertion Rate

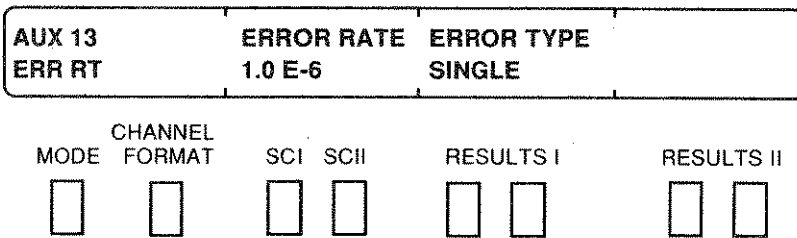

The AUX 13 ERR RT function selects the BPV and logic error insertion, type, rate and burst length for the **BPV** and **LOGIC ERROR INSERT** switches (see Section 13.3.7, **ERROR INSERT** Switches). The Auxiliary function is controlled by the following switches:

SCII switch — Press the **SCII** switch to set the ERROR RATE from 9.9 E-9 to 1.0 E-2. The default is 1.0 E-3. The ERROR RATE sets the error rate for continuous and burst error insertion. The displayed error rates are interpreted as follows:

- 1.0 E-2 = 0.01 = 1 bit error in 100 bits sent.
- 1.0 E-3 = 0.001 = 1 bit error in 1000 bits sent.
- 1.0 E-4 = 0.0001 = 1 bit error in 10,000 bits sent.
- 1.0 E-5 = 0.00001 = 1 bit error in 100,000 bits sent.
- 1.0 E-6 = 0.000001 = 1 bit error in 1 million bits sent.
- 1.0 E-7 = 0.0000001 = 1 bit error in 10 million bits sent.
- 1.0 E-8 = 0.00000001 = 1 bit error in 100 million bits sent.
- 1.0 E-9 = 0.000000001 = 1 bit error in 1 billion bits sent.

RESULTS I Category switch — Press the **RESULTS I Category** switch to select the ERROR TYPE (SINGLE or BURST). When BURST is selected, the burst length (BURST LEN) selection appears in the RESULTS II display. The ERROR TYPE (single or burst) determines how many errors are injected into the transmitted data when pressing the **BPV** and **LOGIC ERROR INSERT** switches for less than 1 second. The error rate during the burst is controlled through the selected ERROR RATE. The following error types are available:

- **SINGLE** — Inserts a single BPV or logic error when the appropriate switch is pressed once.
- **BURST** — Inserts a burst of BPV or logic errors from 20 milliseconds to 5 seconds when the appropriate switch is pressed once. The BURST LEN is displayed and selected from the RESULTS II display.

NOTE: When the **ERROR INSERT** switches are held in for more than 1 second, errors are inserted continuously at the selected error rate.

RESULTS II Results switch — When BURST LEN appears in the RESULTS II display, press the **RESULTS II Results** switch to set the BURST LEN from 20 ms to 5.0 sec. The burst length is incremented in the following manner.

- 20 ms to 170 ms in 50 ms steps.
- 170 ms to 200 ms in a 30 ms step.
- 200 ms to 500 ms in 50 ms steps.
- 500 ms to 1.0 sec. in 100 ms steps.
- 1.0 sec. to 1.5 sec. in 0.1 sec. steps.
- 1.5 sec. to 5.0 sec. in 0.5 sec. steps.

AUX 13	ERROR RATE	ERROR TYPE	BURST LEN
ERR RT	1.0 E-6	BURST	20 ms

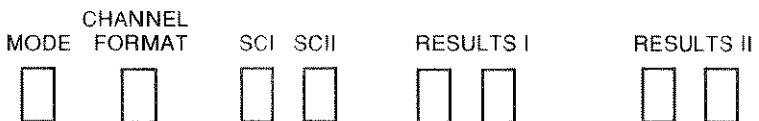

SECTION 13

13.4.4 AUX 14 FRM ERR — Set Consecutive Frame Error Insertion

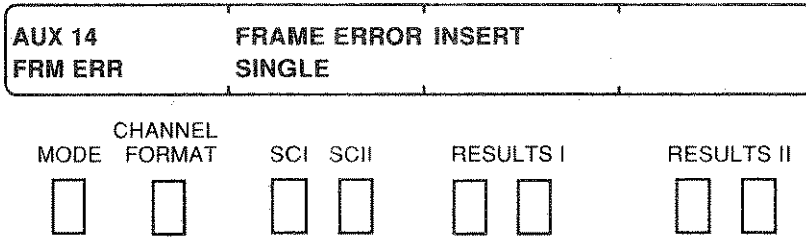

The AUX 14 FRM ERR function selects the number of consecutive frame errors inserted into the T1 framing pattern when the **FRAME ERROR INSERT** switch is pressed. The Auxiliary function is controlled by the following switch:

SCII switch — Press the **SCII** switch to select either SINGLE frame errors or 2 to 6 CONSECutive frame errors.

When the **FRAME ERROR INSERT** switch is pressed for more than 1 second, the number of selected frame errors is inserted continuously. The F_i bits in T1-D1D, T1-D2, T1-D4, and T1SLC96 framing modes and the FPS bits in the ESF and ESFz framing modes are errored when the **FRAME ERROR INSERT** switch is pressed. The AUX 14 FRM ERR function is only functional in framed operating modes (i.e., not unframed T1). The frame error insert default is SINGLE.

13.4.5 AUX 15 USER — Set User Programmable Test Pattern

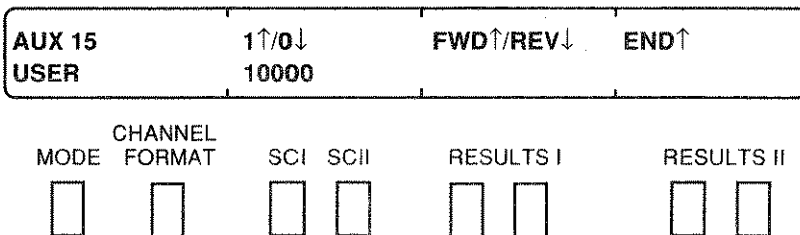

The AUX 15 USER function enables a 3- to 24-bit user programmable test pattern to be entered. The AUX 15 USER function is controlled by the following switches:

SCII switch — Press the **SCII** switch UP arrow to change the current bit to a 1 and move the cursor to the next bit. Press **SCII** switch DOWN arrow to change the current bit to a 0 and move the cursor to the next bit.

RESULTS I Category switch — Press the **RESULTS I Category** switch up to move the cursor forward from left to right. Press the **RESULTS I Category** switch down to move the cursor backward from right to left.

RESULTS II Results switch — Press the **RESULTS II Results** switch UP arrow to save and END the displayed bit pattern up to the position of the cursor. Any bits to the right of the cursor are deleted and the cursor returns to the left most bit position. The first three bits cannot be deleted.

The Auxiliary function allows the T-BERD 224 to transmit specific bit patterns to test circuit sensitivity to the pattern. The default is 10000.

AUX 15	1↑/0↓	FWD↑/REV↓	END↑
USER	10000100011	10000100011	00

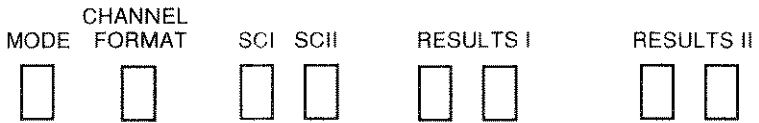

When the operating mode is displayed and **USER** is selected with the **SCII** switch, the pattern is transmitted from left to right as displayed. A test restart only occurs when the pattern is being saved and transmitted at the same time. Perform the following procedure to enter a user programmable test pattern.

- (1) Press the **AUX** switch to select the Auxiliary functions and the **MODE** switch to select the **AUX 15 USER** function.
- (2) Press the **RESULTS I Category** switch to move the cursor FWD or REV.
- (3) Press the **SCII** switch UP arrow to set the bit at the cursor to a 1 or the **SCII** switch DOWN arrow to set the bit to a 0.
- (4) Repeat Steps (2) and (3) until the desired bit pattern is displayed.

SECTION 13

- (5) Move the cursor to the end of the desired bit pattern and press the **RESULTS II Results** switch UP arrow to END and save the bit pattern.
- (6) Press the **AUX** switch to return to the current operating mode.
- (7) Press the **SCI** switch to select the USER test pattern. Selecting the test pattern restarts the test.

13.4.6 AUX 16 PGM LP — Set User Programmable Loop Codes

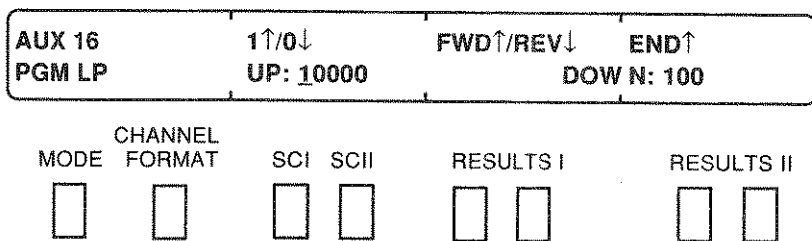

The AUX 16 PGM LP function enables a 3- to 8-bit user programmable loop code to be entered. The AUX 16 PGM LP function is controlled by the following switches:

SCII switch — Press the **SCII** switch UP arrow to change the current bit to a 1 and move the cursor to the next bit. Press **SCII** switch DOWN arrow to change the current bit to a 0 and move the cursor to the next bit.

RESULTS I Category switch — Press the **RESULTS I Category** switch up to move the cursor forward from left to right. Press the **RESULTS I Category** switch down to move the cursor backward from right to left. The switch also moves the cursor between the loop-UP code and loop-DOWN code positions.

RESULTS II Results switch — Press the **RESULTS II Results** switch UP arrow to save and END the displayed loop-up and loop-down bit patterns. If the cursor is positioned in the UP bit pattern and **RESULTS II Results** switch is pressed, any UP bits to the right of the cursor are deleted, the bits to the left are saved, and all the displayed DOWN bits are also saved. If the cursor is positioned in the DOWN bit pattern and **RESULTS II Results** switch is pressed, any DOWN bits to the right of the cursor are deleted, the bits to the left are saved, and all the displayed UP bits are also saved.

The Auxiliary function allows the T-BERD 224 to transmit loop codes other than the standard loop codes that are selectable from the AUX 17 LOOP CD function. The default loop-up code is 10000 and the loop-down code is 100.

The loop codes are transmitted from left to right as displayed. The loop code is transmitted when the T1 PROGRAM loop code is selected from the AUX 17 LOOP CD function (see Section 13.4.7, AUX 17 LOOP CD — Set Loop Code Type).

13.4.7 AUX 17 LOOP CD — Set Loop Code Type

AUX 17 LOOP CD	TYPE T1	EQUIP CSU	
---------------------------	--------------------	----------------------	--

	CHANNEL MODE FORMAT	SCI SCII	RESULTS I	RESULTS II
<input type="checkbox"/>	<input type="checkbox"/>	<input type="checkbox"/> <input type="checkbox"/>	<input type="checkbox"/> <input type="checkbox"/>	<input type="checkbox"/> <input type="checkbox"/>

The AUX 17 LOOP CD function selects the loop code type, equipment, and location (when required) transmitted when the **LOOP CODES** switches are pressed. The loop code selection also selects the T1 loop code the T-BERD 224 automatically responds to (see Section 13.4.8, AUX 18 AUT RES — Set Automatic T1 Loop Code Response). The Auxiliary function is controlled by the following switches:

SCII switch — Press the **SCII** switch to select the loop code type listed in Table 13-2.

RESULTS I Category switch — Press the **RESULTS I Category** switch to select the desired equipment to be looped. Table 13-2 lists the available equipment under each loop code type.

RESULTS II Results switch — When the DDS-LAT type and DS0-DP equipment are selected, pressing the **RESULTS II Results** switch selects the desired LOCATION (1 to 8), which appears in the RESULTS II display, to be looped.

SECTION 13

AUX 17 LOOP CD	TYPE DDS-LAT	EQUIP DS0-DP	LOCATION 1
---------------------------------	-------------------------------	-------------------------------	-----------------------------

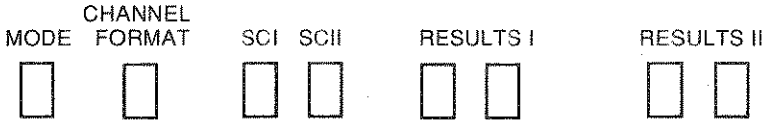

The T1 type loop codes enable the T-BERD 224 to process loop codes over full T1 bandwidths. The DDS-LAT and DDS-ALT type loop codes enable DDS circuits to be looped. Transmitting and responding to loop codes restarts the test.

NOTE: The selected loop code is transmitted only in the bandwidth selected by the **CHANNEL FORMAT** and **CHANNEL** switches. To loop T1 CSUs and smart jacks, the channel format must be set to FULL T1.

Table 13-2
Loop Codes

Type	Equip/Loc	Bit Pattern		Description
		Loop Up	Loop Down	
T1	CSU	10000	100	Customer Service Unit loop codes.
	FAC1	1100	1110	In-band 4-bit Facility or network (or smart jack) loop codes.
	FAC2	11000	11100	In-band 5-bit Facility or network (or smart jack) loop codes.
	PROGRAM	10000 (default)	100 (default)	3- to 8-bit programmable loop codes. See AUX 16 PGM LP, Section 13.4.6.
	ESF-LIN*	0111 0000	0001 1100	ESF out-of-band Line loop codes.
	ESF-PAY*	0010 1000	0100 1100	ESF out-of-band Payload loop codes.

Table 13-2
Loop Codes (Continued)

Type	Equip/Loc	Bit Pattern		Description
		Loop Up	Loop Down	
DDS-ALT	ESF-NET*	0100 1000	0010 0100	ESF out-of-band Network loop codes.
	OCU	x010 1010	N/A	Alternating Office Channel Unit loop code.
	OCU+HL96	x010 1010	N/A	Alternating Office Channel Unit loop code behind a HL96NY.
	HL96NY	x010 1010	N/A	Alternating HL96NY Office Channel Unit loop code.
	DSU	x010 1100	N/A	Alternating Data Service Unit loop code.
	CHANNEL	x010 1000	N/A	Alternating Channel Service Unit loop code.
	CHAN+1R	x010 1000	N/A	Alternating Channel Service Unit behind one repeater loop code.
	CHAN+2R	x010 1000	N/A	Alternating Channel Service Unit behind two repeaters loop code.
	1ST RPTR	x010 1000	N/A	Alternating First Local Loop repeater loop code.
	2ND RPTR	x010 1000	N/A	Alternating Second Local Loop repeater loop code.
DDS-LAT	OCU	**	**	Latching Office Channel Unit loop code.
	CHANNEL	**	**	Latching Channel Service Unit loop code.

**Table 13-2
Loop Codes (Continued)**

Type	Equip/Loc	Bit Pattern		Description
		Loop Up	Loop Down	
	DS0-DP (LOCATION 1 to 8)	**	**	Latching DS0-Dataport loop code. When more than one DS0-DP is present, select the location of the DS0-DP from 1 to 8.
	LSI	**	**	Latching Line Side Interface (HL222) loop code.

NOTES:

- * Only used with ESF and ESFz modes.
- ** As described in TA-TSY-000055, Issue 3, April 1987.
- x = subrate framing bit when the byte is transmitted or received as a DS0B or DS0A 19.2 kb/s signal. Framing bit pattern determined by DS0B or DS0A 19.2 kb/s data rate.
- x = a "don't care" mode when the byte is received at a DS0A subrate, except DS0A 19.2 kb/s.
- x = a "1" when the byte is transmitted at a DS0A subrate, except DS0A 19.2 kb/s.
- x = a "0" when control codes (except IDLE) are transmitted at the DS0A 56 kb/s rate.
- x = a "don't care" mode when control codes (except IDLE) are received at the DS0A 56 kb/s rate.
- x = a "1" when the IDLE code is transmitted or received at the DS0A 56 kb/s rate.

13.4.8 AUX 18 AUT RES — Set Automatic T1 Loop Code Response

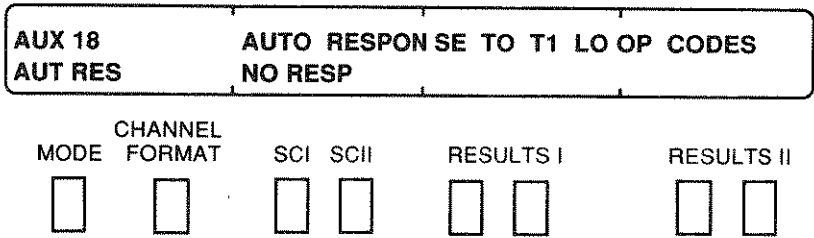

The AUX 18 AUT RES function determines whether the T-BERD 224 enters an automatic line loopback mode in response to a received in-band or out-of-band T1 loop code. The Auxiliary function is controlled by the following switch:

SCII switch — Press the **SCII** switch to set the loop code response to either NO RESPONSE or AUTO RESPONSE.

NO RESP — The T-BERD 224 does not respond to received loop codes.

AUTO RESP — The T-BERD 224 automatically responds to the received T1 loop-up codes by entering either the AUTO LLB, AUTO PLB, or FT1 LLB mode. The AUTO LLB mode indicates the T-BERD 224 has responded to either a CSU, FAC1, FAC2, PROGRAM, ESF-LIN, or ESF-NET loop code. The AUTO PLB mode indicates the T-BERD 224 has responded to the ESF-PAY loop code. The FT1 LLB mode indicates the T-BERD 224 has responded to a loop code when the channel format is set to 56 x N or 64 x N. The instrument only responds to T1 loop codes matching the T1 loop code selected from the AUX 17 LOOP CD function (see Section 13.4.7, AUX 17 LOOP CD — Set Loop Code Type).

In AUTO RESPONSE mode, the T-BERD 224 enters AUTO LLB mode after receiving 5 seconds of in-band loop-up code or after receiving seven out of ten ESF out-of-band loop-up codes. If the T-BERD 224 is set to T1 LLB mode, the T-BERD 224 does not respond to the received loop codes. AUTO LLB is exited after receiving the in-band or ESF out-of-band loop-down code. When the loopback is disabled, the instrument also returns to the previously selected operating mode. When in AUTO LLB mode, the

SECTION 13

T-BERD 224 emulates a CSU in loopback. AUTO LLB functions the same as the T1 LLB operating mode. The AUX 18 AUT RES function default is NO RESPonse.

13.4.9 AUX 19 DDS CHN — Set DDS Analysis Channel and Pattern

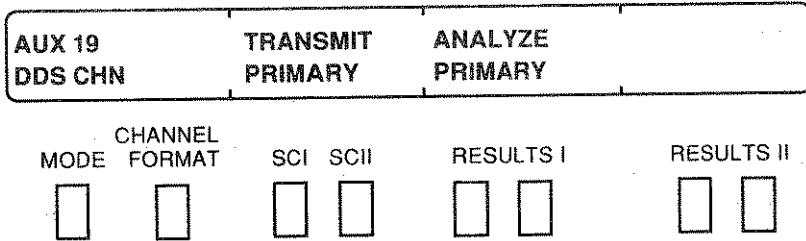

The AUX 19 DDS CHN function determines how the T-BERD 224 tests the DDS primary and secondary channel data. The Auxiliary function is controlled by the following switches:

SCII switch — Press the **SCII** switch to select which DDS channel the pattern is transmitted on, i.e., PRIMARY, SECONDARY, or BOTH.

RESULTS I Category switch — Press the **RESULTS I Category** switch to select which channel is being analyzed, PRIMARY or SECONDARY, when the TRANSMIT selection is set to BOTH. Otherwise, the ANALYZE channel defaults to the TRANSMIT selection.

RESULTS II Results switch — Press the **RESULTS II Results** switch to select the SEC CH PAT (secondary channel test pattern), 511 or 2047, when the TRANSMIT selection is set to SECONDARY or BOTH.

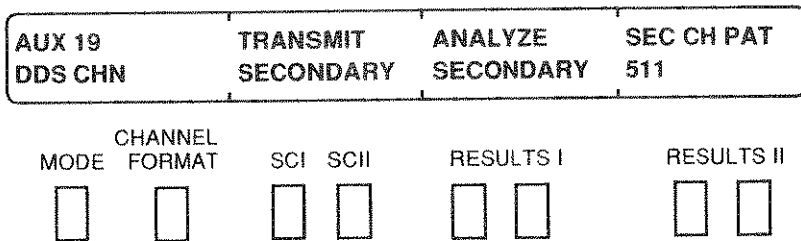

The T-BERD 224 can transmit data on either the primary or secondary channel, or on both channels simultaneously. It can analyze the data on either channel one at a time. The PATTERN SYNC LED illuminates when pattern synchronization is detected on the channel being analyzed. Table 13-3 indicates the possible transmit, analysis, and secondary channel pattern configurations.

Table 13-3
Testing DDS Channels

Transmit	Analyze	Secondary Channel Pattern
Primary	Primary	Idle code
Both	Primary	511 or 2047
Both	Secondary	511 or 2047
Secondary	Secondary	511 or 2047

When the TRANSMIT selection is set to PRIMARY or BOTH, the selected test pattern appears in the SCI display when the mode and channel format are displayed. Pressing the **SCI** switch selects the desired test pattern. The AUTO pattern search channel format only applies to the transmitted primary channel. When the TRANSMIT selection is set to SECONDARY, the selected secondary channel test pattern appears in the SCI display when the mode and channel format are displayed. If the DSU-DP Option is installed and the mode and channel format are displayed, pressing the **SCI** switch selects either the secondary channel test pattern or the DSU-DP.

NOTE: When performing DDS alternating loopback testing, the AUX 19 DDS CHN function TRANSMIT and ANALYZE selections should be set to PRIMARY.

SECTION 13

13.5 TEST PATTERNS

All patterns can be used in any framed or unframed operating mode. The patterns are not be transmitted in the T1 TLB, T1 LLB, or FT1 LLB modes. However, to obtain logic results for these modes, frame synchronization must be achieved and the received pattern must match the selected test pattern.

NOTE: Changing test patterns always restarts the T-BERD 224 (see Section 2.3.2, **RESTART** Switch [7]).

When in-band loop codes are transmitted (see Section 13.3.8, **LOOP CODES** Switches), the transmission of the test pattern is temporarily halted and the loop code name temporarily replaces the test pattern name in the SCI and SCII displays. When loop code transmission is terminated, the test pattern is transmitted and reappears in the display. When an ESF out-of-band loop code is transmitted, the test pattern continues to be transmitted.

13.5.1 ALL ONES — All Ones Pattern

The **ALL ONES** pattern is a fixed test pattern of only AMI pulses (Mark). **ALL ONES** is generally used to stress span repeater current regulator circuits. It can be used as an Alarm Indication Signal (AIS) in unframed circuits, or a keep alive signal, or idle code. The pattern is required to measure the T1 signal power in dBm when measured in the **SIGNAL** category n42 RX LVL result.

13.5.2 ALL ZERO — All Zeros Pattern

The **ALL ZERO** pattern allows the T-BERD 224 to test T1 circuits for B8ZS clear channel capability (CCC). The pattern can be transmitted framed or unframed, or with the T1-ESFz mode selected (see Section 2.3.2, **MODE** Switch [2]). When using the **ALL ZERO** pattern and B8ZS coding, the T-BERD 224 can test a circuit for spans that are not configured for or are not compatible with B8ZS encoded data.

NOTE: The **CODE** switch should be set for B8ZS when sending the **ALL ZERO** pattern.

When the T-BERD 224 is configured for B8ZS operation (CODE switch set for B8ZS) and the ALL ZERO test pattern is transmitted, the T-BERD 224 monitors the received signal for the normal B8ZS sequence, 000V 10V1 (where V is a bipolar violation). However, if the T-BERD 224 receives the B8ZS sequence in an AMI format (0001 1011) instead of all zeros (0000 0000) after decoding, the T-BERD 224 reports the sequence as an error and displays the message NOT B8ZS COMPATIBLE in the SUMMARY category. Testing circuits for B8ZS compatibility is only possible when the T-BERD 224 channel format is set for either FULL T1, 64 x N, or DSX064. The failure of the network to maintain the B8ZS sequence in the received ALL ZERO pattern can occur at a multiplexer or DSX with an improperly set equipment coding option; the coding option would be set for AMI instead of B8ZS.

13.5.3 USER — User Programmable Bit Pattern

The **USER** pattern provides the ability to transmit a 3- to 24-bit user programmable test pattern. This allows the T-BERD 224 to transmit specific bit patterns to test a circuits sensitivity to a particular pattern. The pattern is entered in binary form through the AUX 15 USER function. The pattern displayed in the AUX 15 USER function is transmitted starting from left to right. The factory default test pattern is 10000.

13.5.4 MIN/MAX — Minimum/Maximum Density Stress Test Pattern

The **MIN/MAX** pattern is a minimum/maximum density stress pattern that is used to test the ability of repeaters to adjust to rapid changes in ones density. The pattern generates rapid transitions from low ones density octets to high ones density octets. The pattern is shown in Appendix D.

13.5.5 2²³-1 — 8,388,607-Bit Pseudorandom Pattern

The 2²³-1 pattern is a pseudorandom pattern which generates a maximum of 22 sequential zeros and 23 sequential ones. The pattern exceeds excess zeros and does not meet the minimum ones density requirements for T1 applications.

SECTION 13

13.5.6 2²⁰-1 — 1,048,575-Bit Pseudorandom Pattern

The 2²⁰-1 pattern is a pseudorandom pattern which generates a maximum of 19 sequential zeros and 20 sequential ones. The pattern exceeds excess zeros and does not meet the minimum ones density requirements for T1 applications.

13.5.7 2¹⁵-1 — 32,767-Bit Pseudorandom Pattern

The 2¹⁵-1 pattern is a pseudorandom pattern which generates a maximum of 14 sequential zeros and 15 sequential ones. The pattern provides a maximum number of zeros allowed for framed, non-B8ZS testing. The pattern does not meet the minimum ones density requirement.

13.5.8 2¹⁵-1 INV — Inverted 32,767-Bit Pseudorandom Pattern

The 2¹⁵-1 INV pattern is a pseudorandom pattern which generates a maximum of 15 sequential zeros and 15 sequential ones. The pattern provides a maximum number of zeros allowed for framed, non-B8ZS testing. The pattern does not meet the minimum ones density requirement. This pattern is compatible with the 2¹⁵-1 pattern defined in the CCITT Recommendation O.151, Specification for Instrumentation to Measure Error Performance on Digital Systems.

13.5.9 QRSS — T1 Quasi-Random Signal Source Pattern

The QRSS pattern simulates live T1 data. T1 QRSS is a modified 2²⁰-1 pseudorandom pattern which allows a maximum of 15 sequential zeros and 20 sequential ones. The Ln 1's DENS VIOLATED message is disabled when this pattern is transmitted.

13.5.10 3 IN 24 — Three Ones In 24-Bits Pattern

The 3 IN 24 pattern is a fixed test pattern of F0100 0100 0000 0000 0000 0100... The pattern is aligned with the framing (F) bits as indicated. 3 IN 24

provides the minimum ones density (12.5%) and the maximum zeros (15) requirement to stress T1 circuits. When the pattern is framed, it violates the ones density criteria, $N/8(N+1)$ bits where $N = 1$ to 23 ones.

13.5.11 1:7 — A One and Seven Zeros Pattern

The **1:7** pattern is a fixed test pattern of F01000000... The pattern is aligned with the framing (F) bits as indicated. 1:7 is generally used to stress the 12.5% ones density requirement for T1 circuits.

13.5.12 63 — 63-Bit Pseudorandom Pattern

The **63** pattern is a 63-bit (2^6-1) pseudorandom pattern that generates a maximum of five sequential zeros and six sequential ones.

13.5.13 511 — 511-Bit Pseudorandom Pattern

The **511** pattern is a 511-bit (2^9-1) pseudorandom pattern that generates a maximum of eight sequential zeros and nine sequential ones. This pattern is generally used to test DDS and other circuits operating below 9.6 kb/s.

13.5.14 2047 — 2047-Bit Pseudorandom Pattern

The **2047** pattern is a 2047-bit ($2^{11}-1$) pseudorandom pattern that generates a maximum of 10 sequential zeros and 11 sequential ones. This pattern is generally used to test DDS and other circuits operating between 9.6 and 56 kb/s.

13.5.15 DDS1 — DDS 1 Stress Pattern

The **DDS1** pattern is a repeating pattern of 100 octets of 1111 1111 and 100 octets of 0000 0000. This pattern provides a minimum and maximum ones density which can stress the DDS circuit signal recovery capability.

SECTION 13

13.5.16 DDS2 — DDS 2 Stress Pattern

The **DDS2** pattern is a repeating pattern of 100 octets of 0111 1110 and 100 octets of 0000 0000. This pattern provides a minimum ones density and simulates bit-oriented protocol flags (e.g., HDLC) to ensure that the DDS circuit can pass the signal properly.

13.5.17 DDS3 — DDS 3 Stress Pattern

The **DDS3** pattern is a continuous series of octets of 0011 0010... which provides a medium ones density and simulates a typical signal transmitted over the DDS circuit.

13.5.18 DDS4 — DDS 4 Stress Pattern

The **DDS4** pattern is a continuous series of octets of 0100 0000... which provides a low ones density.

13.5.19 AUTO — Automatic Pattern Search

AUTO enables the T-BERD 224 to automatically search for and recognize a known test pattern on the dropped line. If the **DROP** switch is set to **BOTH**, only **LINE 1** is searched. If a pattern match occurs, the pattern name appears in the SCI display in lower-case characters, replacing **AUTO**. The lower-case characters are a reminder that the T-BERD 224 is in **AUTO** mode. While displaying **AUTO**, the T-BERD 224 is in a through mode allowing data to pass. When the pattern is recognized, the T-BERD 224 transmits the pattern on the inserted line. If the T-BERD 224 does not recognize any pattern, the unit remains in the through mode. When testing DDS circuits, the **AUTO** mode only applies to the primary channel.

13.6 MEASUREMENTS

The **SUMMARY**, **LOGIC**, **SIGNAL**, and **TIME** categories are affected by the **BERT** Option. Unless otherwise indicated, the other categories are also available during testing.

13.6.1 SUMMARY Category Measurements

The LOGIC category result, n00 BIT ERR and n09 PAT SLP, appear in the SUMMARY category when bit errors or pattern slips are recognized in the data stream. Refer to Section 13.6.2, LOGIC Category Measurements, for more information on the bit error result and additional logic results.

The message “NOT B8ZS COMPATIBLE” appears in the SUMMARY category when the circuit fails the B8ZS compatibility test (see Section 13.3.9, Status and History Indicators). The message “Ln 1’s DENS VIOLATED” also appears in the SUMMARY category when the T1 signal violates the ones density criteria, $N/8(N+1)$ bits where $N = 1$ to 23 ones.

13.6.2 LOGIC Category Measurements

The LOGIC category results are only available when performing out-of-service tests with standard T-BERD 224 test patterns and when loop codes are not being transmitted (see Sections 13.5, Test Patterns, and 13.3.8, **LOOP CODES** Switches). Logic results are only available after pattern synchronization is achieved. If signal, frame, or pattern synchronization is lost during testing, the logic result counts halt until the signal, frame, and pattern synchronization are reestablished. Table 13-4 describes the available LOGIC category results.

Table 13-4
LOGIC Category Results

Results Name	Description
n00 BIT ERR	Bit Errors — A count of received bits that have a value opposite that of the corresponding transmitted bits (Mark or Space) after pattern synchronization is achieved.
n01 ASYN ES	Asynchronous Errored Seconds — A count of test seconds where one or more bit errors occurred.
n04 BER	Bit Error Rate — The ratio of bit errors to received pattern data bits.
n05 EFS	Error-Free Seconds — A count of the seconds during which pattern synchronization is maintained through the entire second and no bit error occurred.
n06 % EFS	Percent Error-Free Seconds — The ratio, expressed as a percentage, of error-free seconds to the total number of seconds during which pattern synchronization is present.
n07 SYN ES	Synchronous Errored Seconds — A count of errored seconds synchronized to the occurrence of an error (the count and time intervals begin with the occurrence of an error).
n08 OOS SEC	Out-of-Synchronization Seconds — A count of the total number of seconds since the beginning of the test during which pattern synchronization was not maintained for the entire second.
n09 PAT SLP	Pattern Slips — A count of the total number of pattern slips detected since the beginning of the test. The result is only valid when using pseudorandom test patterns. A pattern slip is a difference (one or more bits are missing or added) between the transmitted and received test pattern.

13.6.3 SIGNAL Category Measurements

The following SIGNAL category results shown in Table 13-5 are included with the BERT Option.

Table 13-5
SIGNAL Category Results

Results Name	Description
n50 SPX CUR	Simplex Current — The magnitude of the simplex current flowing between the LINE 1 receiver and LINE 2 transmitter, or LINE 2 receiver and LINE 1 transmitter. The line number is determined by the DROP switch setting. The result measurement range is 0 mA to 250 mA with an accuracy of ± 2 mA.
n53 DELAY	Round Trip Delay — The time it takes a pseudorandom test pattern to be transmitted and received in a loopback test. The result can measure round trip delay from 0.324 ms to 10 seconds.

SECTION 13**13.6.4 CHANNEL Category Measurements**

Table 13-6 describes the DDS channel results made available with the BERT Option. The results are only available when the T-BERD 224 is configured for DDS testing.

Table 13-6
CHANNEL Category Results

Results Name	Description
n80 RCV BYT	DDS Received Byte — Displays the received 8-bit byte of the selected channel. If the received byte is recognized as a control code, the control code name is displayed in the n95 RCODE result.
n95 RCODE	Reportable DS0 Control Code — Displays the name of the received DS0 code identified in the n80 RCV BYT result. Table 13-7 lists the code ID, byte, and description of the reportable DS0 control codes.
n96 DDS F E	DDS Frame Errors — A count of the DS0B frame errors detected since the start of the test. Subrate DS0B frame synchronization must be present to display the result.
n98 % IN SRV	Percent of In-Service Secondary Bits — The percentage of Bit 8 transitions while processing DS0 framed subrates.

Table 13-7
Reportable DS0 Control Codes

Code ID	Control Byte	Description
ASC	x001 1110	Abnormal Station Condition
BLOCK	x000 1010	MJU Block Code
C IDLE	x111 1110	Control Code Idle
CHAN	x010 1000	Alternating Channel (CSU) Loopback
D IDLE	x111 1111	Data Idle Code
DSU	x010 1100	Alternating DSU Loopback
FEV	x101 1010	Far End Voice
LBE	x101 0110	Loopback Enable
MA	x111 0010	MJU Alert Code
MAP0	x001 0011	MAP 0 Confirmation Code (line side)
MAP1	x110 1101	MAP 1 Confirmation Code (drop side)
MOS	x001 1010	Multiplexer Out of Synchronization
OCU	x010 1010	Alternating OCU Loopback
RELEASE	x111 1000	MJU Release Code
TA	x110 1100	Test Alert
TEST	x001 1100	Test Code
TIP	x011 1010	Transitions In Progress
UMC	x001 1000	Unassigned Multiplexer Channel

x = a substrate framing bit when the byte is transmitted or received as a DS0B signal. Framing bit pattern determined by DS0B data rate.

x = a "don't care" mode when the byte is received at a DS0A substrate.

x = a "1" when the byte is transmitted at a DS0A substrate.

x = a "0" when control codes (except IDLE) are transmitted at the DS0A 56 kb/s rate.

x = a "don't care" mode when control codes (except IDLE) are received at the DS0A 56 kb/s rate.

x = a "1" when the IDLE code is transmitted or received at the DS0A 56 kb/s rate.

SECTION 13

13.6.5 TIME Category Measurements

The n71 ALM SEC result also counts ones density violations in its count of test seconds. Refer to Section 2.6.5, TIME Category, for additional information on the Alarm Second result.

13.7 OUT-OF-SERVICE TESTING

The following procedures describe test capabilities provided by the BERT Option. These test procedures demonstrate how the T-BERD 224 can test a looped back full T1 circuit, replace the customer CSU and measure simplex current, and stress an individual DS0B data channel.

13.7.1 FULL T1 Loopback Test

This procedure explains how to loop an ESF CSU with the T-BERD 224 to test a full T1 circuit with one of several available test patterns, e.g., QRSS, 3 IN 24, 2¹⁵-1, etc. Logic, BPV, frame, and CRC errors can be monitored and evaluated to determine the quality and integrity of the T1 circuit. Figure 13-1 illustrates how the T-BERD 224 is connected to the span through the DSX-1 patch panel and setup in a terminated connection. Table 13-8 configures the T-BERD 224 to test the full T1 bandwidth over an ESF circuit.

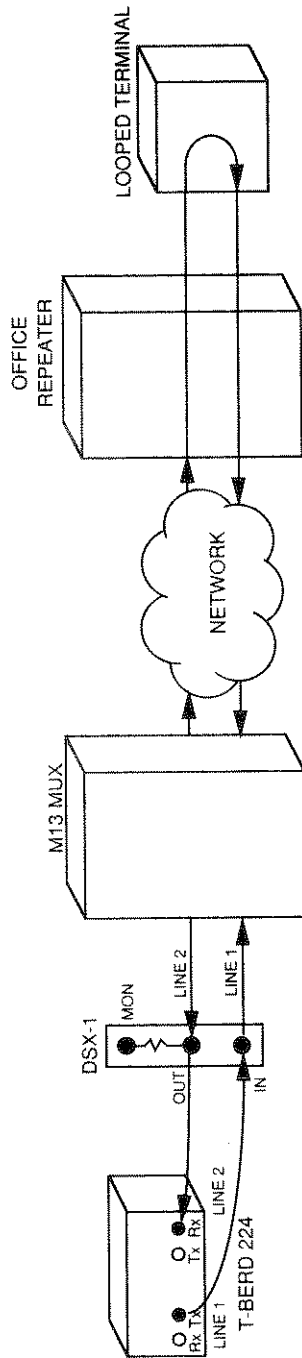

Figure 13-1
Loopback Test Set-Up

Table 13-8
FULL T1 Out-of-Service Test

Step	Controls/ Indicators/ Connections	Activity
1.	T1 Circuit Connections	<p>Perform the procedure in Section 4.2.3, T1 Circuit Termination, to connect the T-BERD 224 for terminating the T1 circuit with the following switch positions:</p> <ul style="list-style-type: none"> (a) MODE switch is set to T1-ESF. (b) CHANNEL FORMAT switch is set to FULL T1. (c) SCI switch is set to the desired test pattern. The QRSS or 3 IN 24 pattern is typically used.
2.	RESULTS I & II switches	<ul style="list-style-type: none"> (a) Display SUMMARY category in the RESULTS I display. (b) Display SIGNAL category, 241-RX LVL (dBdsx) result, in the RESULTS II display.
3.	AUX switch	Select Auxiliary functions (AUX switch LED illuminates).
4.	MODE switch	<ul style="list-style-type: none"> (a) Select AUX 06 BACK TM. Set to INTERNAL (see Section 2.5). (b) Select AUX 17 LOOP CD. Set TYPE to T1 and EQUIP to ESF-LIN. The loop code can be changed as required to further sectionalize the span during testing (see Section 13.4.7).
5.	AUX switch	Release Auxiliary functions (AUX switch LED is extinguished).
6.	DISPLAY HOLD, LOOP CODES, SIGNALING INSERT, and ERROR INSERT switches	Verify that all switches are released (switch LEDs are extinguished).
7.	TEST switch	Set to CONT. or TIMED testing as required.

Table 13-8
FULL T1 Out-of-Service Test (Continued)

Step	Controls/ Indicators/ Connections	Activity
8.	LINE 1 switches	(a) Ignore CHANNEL switch display (— — appear for FULL T1). (b) Set RECEIVE INPUT switch to TERM.
9.	LINE 2 switches	(a) Ignore CHANNEL switch display (— — appear for FULL T1). (b) Set RECEIVE INPUT switch to TERM.
10.	DROP switch	Set to LINE 2 (LINE 2 LED illuminates).
11.	INSERT switch	Set to LINE 1 (LINE 1 LED illuminates).
12.	LOOP UP switch	Send ESF-LIN loop-up code to remote site to enable loopback. Switch LED illuminates until loop code is detected. After successfully establishing the loopback, a test restart is initiated.
13.	Test Verification	Check the following conditions for an operational test. (a) LINE 2 SIGNAL LED - Illuminates when the T1 signal is detected. (b) LINE 2 FRAME SYNC LED - Illuminates when the proper framing mode is selected and the receiver is synchronized to the received framing pattern. (c) LINE 2 PATTERN SYNC LED - Illuminates when the receiver is synchronized to received test pattern, e.g., 3 IN 24. (d) B8ZS LED - Illuminates when B8ZS encoded data is detected. (e) EXCESS ZEROS, YELLOW ALARM, and AIS should not illuminate. (f) 241-RX LEVEL - Level should be between -2 dBdsx and +2 dBdsx for terminated jacks.
14.	LOGIC ERROR INSERT switch	Press switch quickly three times. Verify that the 200-BIT ERR result appears in the RESULTS I display. If necessary, press the RESULTS I Results switch to scroll through the SUMMARY category. Three bit errors should be registered in the result.

Table 13-8
FULL T1 Out-of-Service Test (Continued)

Step	Controls/ Indicators/ Connections	Activity														
15.	RESTART switch	Press to restart test and clear all results. Formal testing of the span starts here. Step 16 identifies which test results to look at during the test.														
16.	RESULTS Verification	<p>Check the SUMMARY category for one or more of the following:</p> <p>(a) RESULTS OK - No error found, span operational. Go to Step 17.</p> <p>(b) Errored Results - non-zero or out of specification results:</p> <table border="0" data-bbox="428 724 838 1027"> <tr> <td>200-BIT ERRORS</td> <td>LOGIC Category</td> </tr> <tr> <td>209-PAT SLP</td> <td>LOGIC Category</td> </tr> <tr> <td>225-BPVS</td> <td>BPV & FRAME Category</td> </tr> <tr> <td>230-FRM ERR</td> <td>BPV & FRAME Category</td> </tr> <tr> <td>232-CRC ERR</td> <td>BPV & FRAME Category</td> </tr> <tr> <td>234-FRM LOS</td> <td>BPV & FRAME Category</td> </tr> <tr> <td>240-RX FREQ</td> <td>SIGNAL Category</td> </tr> </table> <p>If frame errors, CRC errors, and BPVs are detected, the errors are being introduced by the near-end T1 span. If frame errors or CRC errors are detected, but no BPVs, the errors are not being introduced at the near-end T1 span and further sectionalization is required. If necessary, reestablish the loopback at another point along the span and repeat the test.</p>	200-BIT ERRORS	LOGIC Category	209-PAT SLP	LOGIC Category	225-BPVS	BPV & FRAME Category	230-FRM ERR	BPV & FRAME Category	232-CRC ERR	BPV & FRAME Category	234-FRM LOS	BPV & FRAME Category	240-RX FREQ	SIGNAL Category
200-BIT ERRORS	LOGIC Category															
209-PAT SLP	LOGIC Category															
225-BPVS	BPV & FRAME Category															
230-FRM ERR	BPV & FRAME Category															
232-CRC ERR	BPV & FRAME Category															
234-FRM LOS	BPV & FRAME Category															
240-RX FREQ	SIGNAL Category															
17.	LOOP DOWN switch	When test is complete, send loop-down code to remote site to release loopback. Disconnect T-BERD 224 from span.														

13.7.2 Testing from the Customer Premises

This procedure places the T-BERD 224 at the customer premises in line between the T1 span and CSU. The T-BERD 224 is configured to operate over a T1-D4 circuit, respond to an in-band CSU loop code enabling the T1 span to be looped back, and measure simplex current. The T1 span is tested from the central office (CO) with the T-BERD 224 acting as a looped CSU. Figure 13-2 illustrates how the T-BERD 224 connects to the T1 span and CSU and setup to terminate the T1 span. Table 13-9 configures the T-BERD 224 to test for simplex current.

NOTE: DSX-1 patch panels may not be available for testing at the customer premises. If not, test cables, such as the Model 41645 (dual bantam to RJ-48) or Model 41648 (dual bantam to 15-pin D-type male connector) should be used to connect the T-BERD 224 to the network equipment.

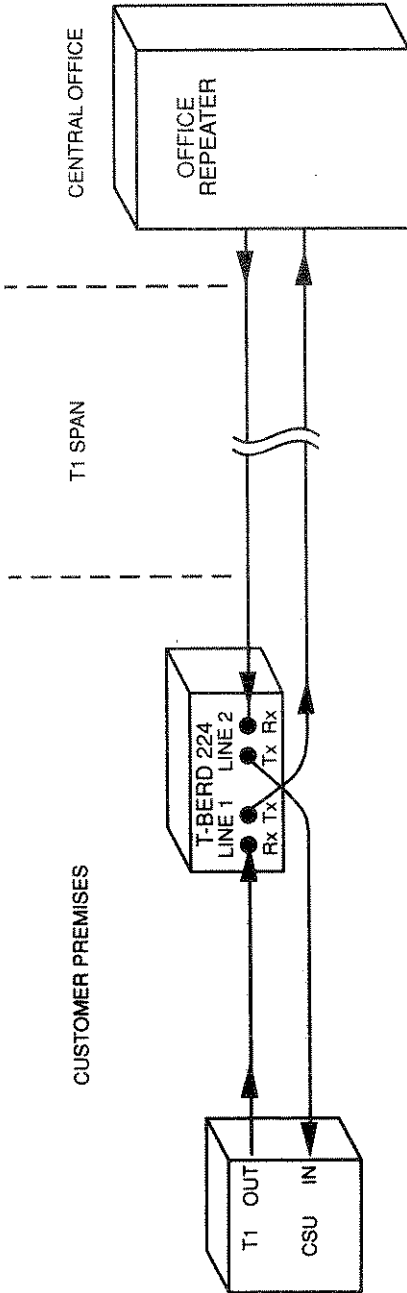

Figure 13-2
Customer Premises Test Set-Up

Table 13-9
Testing from the Customer Premises

Step	Controls/ Indicators/ Connections	Activity
1.	T1 Circuit Connections	Perform the procedure in Section 4.2.2, Drop and Insert Testing, to connect the T-BERD 224 between the CSU and T1 circuit with the following switch positions: <ul style="list-style-type: none"> (a) MODE switch is set to T1-D4. (b) CHANNEL FORMAT switch is set to FULL T1. (c) SCI switch is set to AUTO. Test pattern is being transmitted from CO.
2.	RESULTS I & II switches	<ul style="list-style-type: none"> (a) Display SUMMARY category in the RESULTS I display. (b) Display SIGNAL category, 150 SPX CUR result, in the RESULTS II display to measure simplex current.
3.	AUX switch	Select Auxiliary functions (AUX switch LED is illuminated).
4.	MODE switch	<ul style="list-style-type: none"> (a) Select AUX 05 LBO. Set line build-out level (0 dB, -7.5 dB, or -15 dB) as required (see Section 2.5). (b) Select AUX 17 LOOP CD. Set TYPE to T1 and EQUIP to CSU. Change loop code as required (see Section 13.4.7). (c) Select AUX 18 AUTRES. Set to AUTO RESP (see Section 13.4.8).
5.	AUX switch	Release Auxiliary functions (AUX switch LED is extinguished).
6.	DISPLAY HOLD, LOOP CODES, SIGNALING INSERT, and ERROR INSERT switches	Verify that all switches are released (switch LEDs are extinguished).
7.	CODE switch	Set for AMI or B8ZS coding.
8.	TEST switch	Set for CONT. or TIMED testing as required.

Table 13-9
Testing from the Customer Premises (Continued)

Step	Controls/ Indicators/ Connections	Activity
9.	LINE 1 switches	(a) Ignore CHANNEL switch display (— — appears for FULL T1). (b) Set RECEIVE INPUT switch to TERM.
10.	LINE 2 switches	(a) Ignore CHANNEL switch display (— — appears for FULL T1). (b) Set RECEIVE INPUT switch to TERM.
11.	DROP switch	Set to LINE 1 (LINE 1 LED illuminates).
12.	INSERT switch	Set to NONE (NONE LED illuminates).
13.	T-BERD 224 Test Verification	Check the following conditions for an operational test: (a) LINE 1/2 SIGNAL LED - Illuminates when the T1 signal is detected. (b) LINE 1/2 FRAME SYNC LED - Illuminates when the proper framing mode is selected and the receiver is synchronized to the received framing pattern. (c) LINE 1 PATTERN SYNC LED - Illuminates when the receiver is synchronized to received test pattern. (d) LINE 1/2 B8ZS LED - Illuminates when B8ZS encoded data is detected. (e) LINE 1/2 EXCESS ZEROS, YELLOW ALARM, and AIS should not illuminate. (f) 150/250 SPX CUR - Level should be between 60 mA to 120 mA.
14.	From CO, send CSU loop-up code to T-BERD 224.	MODE display indicates AUTO LLB. SCI display indicates received test pattern. LINE 1 RECEIVE is looped to LINE 2 TRANSMIT. CSU is disconnected from T1 span (idle code transmitted to CSU).

Table 13-9
Testing from the Customer Premises (Continued)

Step	Controls/ Indicators/ Connections	Activity												
15.	CO Test Verification	Loopback successfully established, signal detected, frame sync achieved, and test pattern detected. Perform additional test as required.												
16.	RESTART switch	Press to restart test and clear all results. Formal testing of the span starts here. Step 17 identifies which test results to look at during the test.												
17.	T-BERD 224 RESULTS Verification	<p>Check the SUMMARY category for one or more of the following:</p> <p>(a) RESULTS OK - No error found, span operational. Go to Step 18.</p> <p>(b) Errored Results - non-zero or out of specification results:</p> <table border="0" data-bbox="585 812 989 1120"> <tr> <td>100-BIT ERRORS</td> <td>LOGIC Category</td> </tr> <tr> <td>125-BPVS</td> <td>BPV & FRAME Category</td> </tr> <tr> <td>130-FRM ERR</td> <td>BPV & FRAME Category</td> </tr> <tr> <td>134-FRM LOS</td> <td>BPV & FRAME Category</td> </tr> <tr> <td>140-RX FREQ</td> <td>SIGNAL Category</td> </tr> <tr> <td>151-TM SLIP</td> <td>SIGNAL Category</td> </tr> </table> <p>If frame errors, CRC errors, and BPVs are detected, the errors are being introduced by the near-end T1 span. If frame errors or CRC errors are detected, but no BPVs, the errors are not being introduced at the near-end T1 span and further sectionalization is required. If necessary, reestablish the loopback at another point along the span and repeat the test.</p>	100-BIT ERRORS	LOGIC Category	125-BPVS	BPV & FRAME Category	130-FRM ERR	BPV & FRAME Category	134-FRM LOS	BPV & FRAME Category	140-RX FREQ	SIGNAL Category	151-TM SLIP	SIGNAL Category
100-BIT ERRORS	LOGIC Category													
125-BPVS	BPV & FRAME Category													
130-FRM ERR	BPV & FRAME Category													
134-FRM LOS	BPV & FRAME Category													
140-RX FREQ	SIGNAL Category													
151-TM SLIP	SIGNAL Category													
18.	From CO, send CSU loop-down code to T-BERD 224.	When test is complete, send loop-down code to remote site to release loopback. Disconnect T-BERD 224 from span and reconnect the CSU.												

SECTION 13

13.7.3 Testing DDS Circuits

This procedure establishes a latching loopback at a DDS OCU to test an individual DS0B channel with one of the DDS stress patterns available through the SCI switch. This procedure also configures the T-BERD 224 to test either the primary or secondary DS0B channel. Logic, BPV, frame, and CRC errors can be monitored and evaluated to determine the quality and integrity of the T1 circuit. Figure 13-3 illustrates how the T-BERD 224 is connected to the span through the DSX-1 patch panel in a drop and insert connection configuration. Table 13-10 prepares the T-BERD 224 to test the DDS DS0B data channels over an ESF circuit.

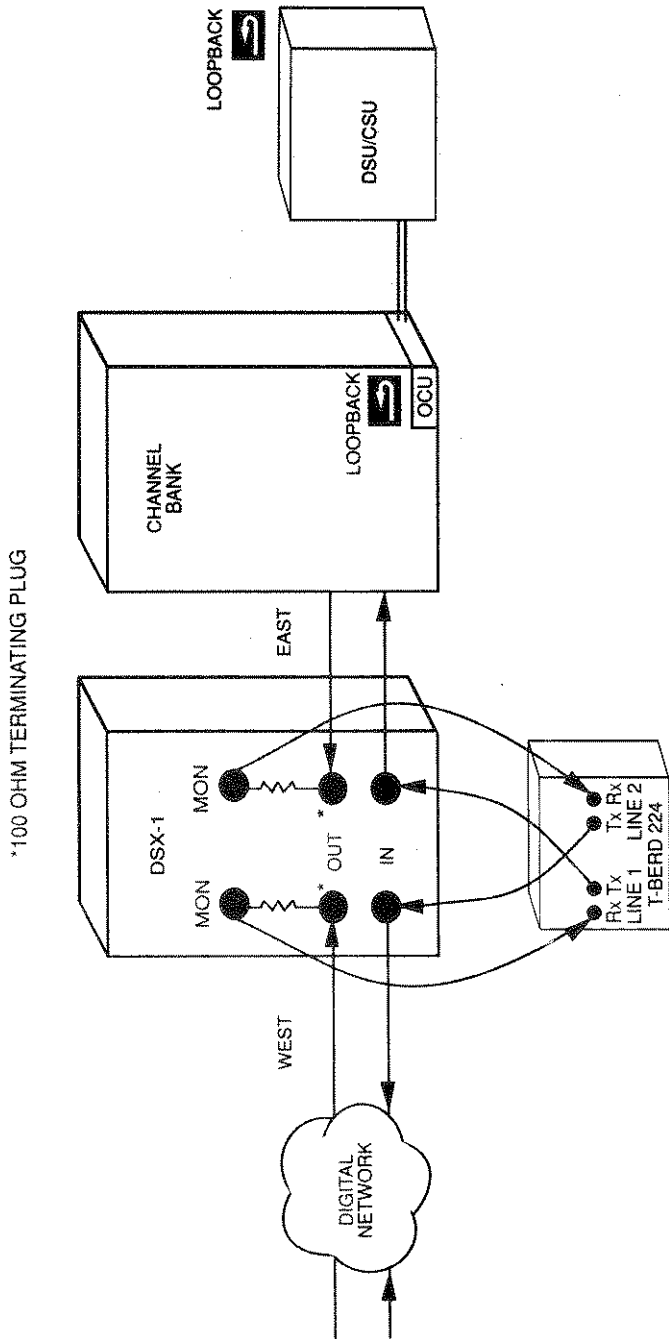

Figure 13-3
DDS Test Set-Up

Table 13-10
DDS Out-of-Service Test

Step	Controls/ Indicators/ Connections	Activity
1.	T1 Circuit Connections	<p>Perform the procedure in Section 4.2.2, Drop and Insert Testing, to connect the T-BERD 224 to the circuit with the following switch positions:</p> <ul style="list-style-type: none"> (a) MODE switch is set to T1-ESF. (b) CHANNEL FORMAT switch is set to DS0B9.6. (c) SCI switch is set to DDS1. The test pattern is transmitted on the primary channel. (d) SCII switch is set to the desired subrate data channel from 1 to 5.
2.	RESULTS I & II switches	<ul style="list-style-type: none"> (a) Display SUMMARY category in the RESULTS I display. (b) Display LOGIC category, 200 BIT ERR result, in the RESULTS II display.
3.	AUX switch	Select Auxiliary functions (AUX switch LED is illuminated).
4.	MODE switch	<ul style="list-style-type: none"> (a) Select AUX 17 LOOP CD. Set TYPE to DDS-LAT and EQUIP to OCU. The loop code can be changed as required to further sectionalize the span during testing (see Section 13.4.7). (b) Select AUX 19 DDS CHN. Set TRANSMIT channel to BOTH, ANALYZE channel to PRIMARY, and SEC CH PAT to 2047 (see Section 13.4.9).
5.	AUX switch	Release Auxiliary functions (AUX switch LED is extinguished).
6.	DISPLAY HOLD, LOOP CODES, SIGNALING INSERT, and ERROR INSERT switches	Verify that all switches are released (switch LEDs are extinguished).

Table 13-10
DDS Out-of-Service Test (Continued)

Step	Controls/ Indicators/ Connections	Activity
7.	CODE switch	Set for AMI or B8ZS coding.
8.	TEST switch	Set for CONT. or TIMED testing as required.
9.	DROP switch	Set to LINE 2 (LINE 2 LED illuminates).
10.	INSERT switch	Set to LINE 1 (LINE 1 LED illuminates).
11.	LOOP UP switch	Send the DDS latching OCU loop-up code to the remote site to enable the OCU loopback. LOOP UP switch LED illuminates until loop code is detected. After successfully establishing the loopback, a test restart is initiated.
12.	Test Verification	<p>Check the following conditions for an operational test.</p> <ul style="list-style-type: none"> (a) LINE 2 SIGNAL LED - Illuminates when the T1 signal is detected. (b) LINE 2 FRAME SYNC LED - Illuminates when the proper framing mode is selected and the receiver is synchronized to the received framing pattern. (c) LINE 2 PATTERN SYNC LED - Illuminates when the receiver is synchronized to received test pattern, e.g., DDS1. (d) B8ZS LED - Illuminates when B8ZS encoded data is detected. (e) EXCESSZEROS, YELLOW ALARM, and AIS should not illuminate. (f) 241-RX LEVEL - Level should be between -15 dBdsx and -25 dBdsx for monitor jacks.
13.	LOGIC ERROR INSERT switch	Press switch quickly three times. Verify that the 200-BIT ERR result appears in the RESULTS I display. If necessary, press RESULTS I Results switch to scroll through the SUMMARY category. Three bit errors should be registered in the result.

**Table 13-10
DDS Out-of-Service Test (Continued)**

Step	Controls/ Indicators/ Connections	Activity														
14.	RESTART switch	Press to restart test and clear all results. Formal testing of the span starts here. Step 15 identifies which test results to look at during the test.														
15.	RESULTS Verification	<p>Check the SUMMARY category for one or more of the following:</p> <p>(a) RESULTS OK - No error found, span operational. Go to Step 16.</p> <p>(b) Errored Results - non-zero or out of specification results:</p> <table border="0" data-bbox="409 716 806 1019"> <tr> <td>200-BIT ERRORS</td> <td>LOGIC Category</td> </tr> <tr> <td>225-BPVS</td> <td>BPV & FRAME Category</td> </tr> <tr> <td>230-FRM ERR</td> <td>BPV & FRAME Category</td> </tr> <tr> <td>232-CRC ERR</td> <td>BPV & FRAME Category</td> </tr> <tr> <td>234-FRM LOS</td> <td>BPV & FRAME Category</td> </tr> <tr> <td>240-RX FREQ</td> <td>SIGNAL Category</td> </tr> <tr> <td>251-TM SLIP</td> <td>SIGNAL Category</td> </tr> </table> <p>If frame errors, CRC errors, and BPVs are detected, the errors are being introduced by the near-end T1 span. If frame errors or CRC errors are detected, but no BPVs, the errors are not being introduced at the near-end T1 span and further sectionalization is required. If necessary, reestablish the loopback at another point along the span and repeat the test.</p>	200-BIT ERRORS	LOGIC Category	225-BPVS	BPV & FRAME Category	230-FRM ERR	BPV & FRAME Category	232-CRC ERR	BPV & FRAME Category	234-FRM LOS	BPV & FRAME Category	240-RX FREQ	SIGNAL Category	251-TM SLIP	SIGNAL Category
200-BIT ERRORS	LOGIC Category															
225-BPVS	BPV & FRAME Category															
230-FRM ERR	BPV & FRAME Category															
232-CRC ERR	BPV & FRAME Category															
234-FRM LOS	BPV & FRAME Category															
240-RX FREQ	SIGNAL Category															
251-TM SLIP	SIGNAL Category															
16.	LOOP DOWN switch	When test is complete, send loop-down code to remote site to release loopback. Disconnect T-BERD 224 from span.														

13.8 REMOTE CONTROL OPERATION

Refer to Section 6, Remote Control Operation, for complete information on the setup and operation of the T-BERD 224 from a remote control device. This section identifies error messages and remote control commands that are added when the BERT Option is installed.

13.8.1 Remote Control Error and Warning Messages

The following error and warning messages appear when a command is improperly entered. Refer to Section 6.4, Error Messages, for additional error messages.

ERROR: *Non-contiguous channel numbers must be in ascending order.*
The FT1 non-contiguous channel numbers were not entered in ascending order.

ERROR: *Non-contiguous channel numbers must be the same length.*
The FT1 number of non-contiguous channel numbers were not the same for both LINE 1 and LINE 2.

ERROR: *Channel number is out of range.*
The channel number is out of range for the current setup.

ERROR: *Selection is not applicable.*
The DS0B channel number is not applicable for the current DS0B channel format.

WARNING: *The value has been rounded down.*
The entered **BUR LEN (value)** has been rounded down to the nearest valid burst length.

13.8.2 Remote Control Commands

Table 13-11 lists the available remote control commands that enable the BERT Option to be controlled from a remote device. The BERT Option remote control commands are described in the following sections. Refer to Section 6.5, Remote Control Commands, for the standard remote control commands.

Table 13-11
Remote Control Commands

Command	Command Name
BEE	Sound Remote Control Beeper
BUR LEN	Set BPV and Logic Error Burst Length
CHA FOR ¹	Channel Format
DDS ANA	Analyze DDS Channel
DDS SEC	Select DDS Secondary Channel Pattern
DDS TRA	Select Transmitted DDS Channel
DS0 ERR COR	DS0A Error Correction
ERR INS BPV ¹	Initiate BPV Error Insertion
ERR INS FRM ¹	Initiate Consecutive Frame Error Insertion
ERR INS LOG	Initiate Logic Error Insertion
ERR RAT	Set BPV and Logic Error Insertion Rate
FRM ERR LEN	Set Consecutive Frame Error Length
HELLO ¹	Display the T-BERD 224 Software Revision Level
HELP ¹	On-Line Help Function
LOO COD	Set Loop Code Type and Pattern
LOO D	Transmit Loop-Down Code
LOO U	Transmit Loop-Up Code
MOD ¹	Set Transmit and Receive Mode
NON C	Non-Contiguous Channel Selection
PGM LPD	Set Programmable Loop-Down Code
PGM LPU	Set Programmable Loop-Up Code
PRI ¹	Initiate Printout
RESP	Set Automatic TI Loop Code Response
SOU 1 ¹	Set Source Configuration I
SOU 2 ¹	Set Source Configuration II
USE	Set User Programmable Test Pattern

¹Available with the standard T-BERD 224.

BEE

BEE

Sound Remote Control Beeper

BEE causes the remote control unit to sound a single short beep.

EXAMPLE:

```
>BEE           :sound the terminal beeper once
>BEE           :and again
>
```

SECTION 13

BUR LEN

BUR LEN

Set BPV and Logic Error Burst Length

BUR LEN? :Displays current burst length

BUR LEN (value) :Sets the burst length (**value**) from 0.020 to 5.0 seconds. Enter (**value**) in milliseconds by entering 20 to 5000. Enter (**value**) in seconds by entering 0.020 to 5.0.

BUR LEN controls the BPV and logic error burst length interval. The following values are the only valid burst length periods:

- 20 ms to 170 ms in 50 ms steps.
- 170 ms to 200 ms in a 30 ms step.
- 200 ms to 500 ms in 50 ms steps.
- 500 ms to 1.0 sec. in 100 ms steps.
- 1.0 sec. to 2.0 sec. in 0.1 sec. steps.
- 2.0 sec. to 5.0 sec. in 0.5 sec. steps.

A value that is not one of the incremental values is always rounded to the nearest lesser value. If a value has a decimal point, the digits after the third fractional position are ignored. This command is identical to setting the burst length with the AUX 13 ERR RT, BURST ERROR TYPE, function.

See also: **ERR RAT**, **ERR INS**, and **FRM ERR LEN**

EXAMPLE:

>BUR LEN 10 :the smallest allowed value is 20 ms

ERROR: Parameter is out of range.

>BUR LEN 5001 :the largest allowed value is 5000 ms

ERROR: Parameter is out of range.

>BUR LEN 0.024 :the smallest allowed decimal value is 0.020

ERROR: Parameter is out of range.

>BUR LEN 5.001 :the largest allowed decimal value is 5.000

ERROR: Parameter is out of range.

>BUR LEN 3.0 :a 3-second burst length is specified

>BUR LEN 3.4 :a 3.4-second burst length is specified

WARNING: The Value has been rounded down.

>BUR LEN ?

BURst LENgth 3.0Sec

>

CHA FOR

CHA FOR

Channel Format

CHA FOR? :Displays the current channel format

CHA FOR [format] :Selects the channel **[format]** for the selected operating mode

CHA FOR selects the T-BERD 224 channel format. Refer to Section 6.5, Remote Control Commands, for additional **CHAnnel FORMat** commands. This command is identical to pressing the **CHANNEL FORMAT** switch. The following additional **CHAnnel FORMat [format]** parameters are included with the current channel formats.

56XN	:56xN FT1 data
64XN	:64xN FT1 data
DAT LIN	:ESF 4 kb/s datalink or ESFz* 2 kb/s datalink formatted data
DS0A2.4	:DS0A formatted DDS data at 2.4 kb/s
DS0A4.8	:DS0A formatted DDS data at 4.8 kb/s
DS0A9.6	:DS0A formatted DDS data at 9.6 kb/s
DS0A19.2	:DS0A formatted DDS data at 19.2 kb/s
DS0A56	:DS0A formatted DDS data at 56 kb/s
DS0B2.4	:DS0B formatted DDS data at 2.4 kb/s
DS0B4.8	:DS0B formatted DDS data at 4.8 kb/s
DS0B9.6	:DS0B formatted DDS data at 9.6 kb/s
DS064	:Clear channel data at 64 kb/s
FUL T1	:Full bandwidth channel format

*Requires ZBTSI Framing Option

NOTE: Changing the channel format causes a test restart and changes the current front panel configuration.

SECTION 13

CHA FOR

CHA FOR

Channel Format (Continued)

EXAMPLE:

```
> CHA FOR?                :display the current channel format
  CHAnnel FORmat VF THRU
> CHA FOR FULL T1        :select FULL T1 as the channel format
WARNING: New Setup:
  MODe T1D4
  CHAnnel FORmat FULL T1
  SOURce 1 BYTe
  SOURce 2 10101010
```

>

DDS ANA**DDS ANA**

Analyze DDS Channel

- DDS ANA?** :Displays the current DDS channel being analyzed
- DDS ANA PRI** :Selects the DDS PRImary channel to be analyzed
- DDS ANA SEC** :Selects the DDS SECondary channel to be analyzed

DDS ANA enables the T-BERD 224 to analyze either the DDS secondary or primary channel. This command is identical to setting the DDS analysis channel with the AUX 19 DDS CHN, ANALYZE, function.

NOTE: If the DDS primary channel is being analyzed, the test pattern is selected with the **SOU 1** command. If the DDS secondary channel is being analyzed, the test pattern is selected with the **DDS SEC** command.

See also **DDS SEC** and **DDS TRA**

EXAMPLE:

- ```
> DDS ANA? :display the current DDS analysis channel
 DDS ANALysis PRImary
> DDS ANA SEC :select DDS secondary channel for analysis
>
```

---

---

**SECTION 13**

**DDS SEC**

**DDS SEC**

Select DDS Secondary Channel Pattern

**DDS SEC?** :Displays the current DDS secondary channel test pattern

**DDS SEC 511** :Selects the 511 test pattern to be transmitted on the DDS secondary channel

**DDS SEC 2047** :Selects the 2047 test pattern to be transmitted on the DDS secondary channel

**DDS SEC** selects the DDS secondary channel test pattern. This command is identical to setting the DDS secondary channel test pattern with the AUX 19 DDS CHN, SEC CH PAT, function.

See also: **DDS ANA** and **DDS TRA**

**EXAMPLE:**

> **DDS SEC?** :display the current DDS secondary channel test pattern

DDS SECondarypat 511

> **DDS SEC 2047** :change the DDS secondary channel test pattern to 2047

>

**DDS TRA****DDS TRA****Select Transmitted DDS Channel**

**DDS TRA?** :Displays the currently transmitted DDS channel

**DDS TRA PRI** :Selects the DDS primary channel to be transmitted

**DDS TRA SEC** :Selects the DDS secondary channel to be transmitted

**DDS TRA BOT** :Selects both DDS channels to be transmitted

**DDS ANA** enables the T-BERD 224 to analyze either the DDS secondary or primary channel. This command is identical to setting the DDS transmit channel with the AUX 19 DDS CHN, TRANSMIT, function.

See also: **DDS ANA** and **DDS SEC**

**EXAMPLE:**

> **DDS TRA?** :display current transmitted DDS channel  
DDS TRANsmit PRImary  
> **DDS TRA BOT** :change transmitted DDS channel to both  
>

---

## SECTION 13

**DS0 ERR COR**

**DS0 ERR COR**

### DS0A Error Correction

**DS0 ERR COR?** :Displays the current status of the DS0A error correction

**DS0 ERR COR [ON|OFF]** :Sets the DS0A error correction

**DS0 ERR COR** allows you to determine if majority-rule error correction is performed on the subrate DS0A data. **DS0 ERR COR ON** causes access to data verified using majority-rule error correction. **DS0 ERR COR OFF** disables majority rule correction of errors.

This command is identical to the AUX 12 ERR COR function.

#### EXAMPLE:

> **DS0 ERR COR?** :display the current DS0A error correction status

DS0a ERRor CORrection OFF

> **DS0 ERR COR ON** :sets the DS0A error correction to ON

>

ERR INS BPV

ERR INS BPV

## Initiate BPV Error Insertion

|                        |                                                                                                                                              |
|------------------------|----------------------------------------------------------------------------------------------------------------------------------------------|
| <b>ERR INS BPV?</b>    | :Displays current BPV error insertion status                                                                                                 |
| <b>ERR INS BPV RAT</b> | :Inserts continuous BPVs into the data stream. The error rate is controlled through the <b>ERR RAT</b> command                               |
| <b>ERR INS BPV BUR</b> | :Inserts a single burst of BPVs. The burst error rate and burst length are controlled through the <b>ERR RAT</b> and <b>BUR LEN</b> commands |
| <b>ERR INS BPV SIN</b> | :Inserts a single BPV. It can also turn off continuous error insertion                                                                       |
| <b>ERR INS BPV OFF</b> | :Stops continuous BPV error insertion                                                                                                        |

**ERR INS BPV** controls the insertion of BPVs into the data stream. This command is identical to pressing the **BPV ERROR INSERT** switch. The command cannot be set when the **INS** command is set to **NONE**.

See also: **ERR RAT** and **BUR LEN**

## EXAMPLE:

```
>ERR INS BPV? :display BPV insertion status
 ERRor INSErt BPV OFF :BPV insertion rate is off
>ERR INS BPV RAT :“turn on” BPV error rate insertion
>ERR INS BPV OFF :“turn off” BPV error rate insertion
>ERR INS BPV? :display BPV insertion status
 ERRor INSErt BPV OFF :BPV insertion is off
>
```

---

---

## SECTION 13

**ERR INS FRA**

**ERR INS FRA**

Initiate Consecutive Frame Error Insertion

**ERR INS FRA?** :Displays current consecutive frame error insertion status

**ERR INS FRA CON** :Inserts continuous single or multiple consecutive frame errors (2 to 6) into the framing bits. The number of frame errors is controlled through the **FRM ERR LEN** command.

**ERR INS FRA SIN** :Inserts a single frame error into the framing bits. It can also turn off continuous error insertion.

**ERR INS FRA OFF** :Stops continuous frame error insertion

**ERR INS FRA** controls the insertion of consecutive frame errors into the framing bits of the data stream. This command is identical to pressing the **FRAME ERROR INSERT** switch. The command cannot be set when the **INS** command is set to **NONE**.

See also: **FRM ERR LEN**

EXAMPLE:

>**ERR INS FRA?** :display current frame error insertion status

**ERRor INSert FRAMe OFF** :frame error insertion is off

>**ERR INS FRA CON** :“turn on” continuous frame error insertion

>**ERR INS FRA SIN** :insert a single frame error and end continuous frame error insertion

>

## ERR INS LOG

## ERR INS LOG

## Initiate Logic Error Insertion

- ERR INS LOG?** :Displays current logic error insertion status
- ERR INS LOG RAT** :Inserts continuous logic errors into the data stream. The error rate is controlled through the **ERR RAT** command.
- ERR INS LOG BUR** :Inserts a single burst of logic errors. The burst error rate and burst length are controlled through the **ERR RAT** and **BUR LEN** commands.
- ERR INS LOG SIN** :Inserts a single logic error. It can also turn off continuous error insertion.
- ERR INS LOG OFF** :Stops continuous logic error insertion

**ERR INS LOG** controls the insertion of logic errors into the data stream. This command is identical to pressing the **LOGIC ERROR INSERT** switch. The command cannot be set when the **INS** command is set to **NONE**.

See also: **ERR RAT** and **BUR LEN**

## EXAMPLE:

- >**ERR INS LOG?** :display logic error insertion status  
 ERRor INSert LOGic OFF :logic error insertion rate is off
- >**ERR INS LOG RAT** :“turn on” logic error rate insertion
- >**ERR INS LOG OFF** :“turn off” logic error rate insertion
- >**ERR INS LOG?** :display logic error insertion status  
 ERRor INSert LOGic OFF
- >



---

---

## SECTION 13

### ERR RAT

### ERR RAT

Set BPV and Logic Error Insertion Rate

**ERR RAT?** :Displays current BPV and logic error insertion rate

**ERR RAT (X.X,Y)** :Sets new BPV and logic error insertion rate (X.X,Y). The X.X,Y format represents the valid error rates from 1.0 E-2 to 9.9 E-9. X.X equals the whole number (1.0 to 9.9) and Y equals the negative exponent (2 to 9). For example, 3.0,6 equals 3.0 E-6.

**ERR RAT** controls the burst and continuous BPV and logic error insertion rates. This command is identical to setting the error rate with the AUX 13 ERR RT, ERROR RATE, function. The maximum error rate can be set to 1.0 E-2 and the minimum error rate can be set to 1.0 E-9.

See also: **ERR INS BPV** and **ERR INS LOG**

#### EXAMPLE:

>**ERR RAT?** :display current error insertion rate  
ERRor RATE 1.0E-7 :the current error insertion rate is 1.0 E-7  
>**ERROR RATE 6.5,5** :change the error insertion rate to 6.5 E-5  
>**ERR RAT?** :display current error insertion rate  
ERRor RATE 6.5E-5 :the current error insertion rate is now 6.5 E-5

>

**FRM ERR LEN****FRM ERR LEN**

Set Consecutive Frame Error Length

**FRM ERR LEN?** :Displays current number of consecutive frame errors being inserted**FRM ERR LEN [x]** :Sets the number of consecutive framing bits to be errored in the framing pattern. [x] equals 1 to 6**FRM ERR LEN** controls the number of framing bits that are consecutively errored in the framing pattern. This command is identical to setting the frame errors with the AUX 14 FRM ERR function.See also: **ERR INS FRA**

EXAMPLE:

**>FRM ERR LEN?** :display current number of consecutive frame errors being inserted

FRM ERR LEN 4 :the current number of consecutive frame errors being inserted is 4

**>FRM ERR LEN 5** :change the number of consecutive frame errors to 5

v

---

---

**SECTION 13**

**HELLO**

**HELLO**

Display the T-BERD 224 Software Revision Level

**HELLO?** :Displays the software revision level and option configurations installed in the T-BERD 224.

“BERT option installed.” appears in the HELLO response indicating the BERT Option is installed. Refer to Section 6.5, Remote Control Commands, for additional **HELLO** command information.

**> HELLO?**

T-BERD 224, Software Version B, (c) TTC 04/05/91  
DSU-DP option installed.  
BERT option installed.  
ZBTSI option installed.

selftest failures:

**>** .....

## HELP

## HELP

## On-Line Help Function

**HELP 10** :Displays help information for the BERT Option Auxiliary function commands

Refer to Section 6.5, Remote Control Commands, for additional **HELP** command information.

> **HELP 10**

TTC On-Line Manual

page 10

The following commands control the operation of the aux functions.

|                  |                                                                                     |
|------------------|-------------------------------------------------------------------------------------|
| BEEp             | - Make The VF speaker beep.                                                         |
| BURst LENgth     | - Select the duration of error burst.                                               |
| DDS ANALYSIS     | - Select PRImary or SECONdary channel analysis.                                     |
| DDS SECONdarypat | - Select the pattern that will be used for SECONdARY channel transmit and analysis. |
| DDS TRANsmitt    | - Select where to transmit on a DDS channel format<br>PRImary, SECONdary or BOTH.   |
| ERRor RATE       | - Enter the error rate.                                                             |
| FRM ERR LEN      | - Select the number of consecutive frame errors.                                    |
| LOOp CODE        | - Specify the loop up and loop down code.                                           |
| RESPonse         | - AUTO response or NO response to loop code.                                        |
| PGM LPUp         | - Enter the user programmable loop up code.                                         |
| PGM LPDn         | - Enter the user programmable loop down code.                                       |
| USER             | - Enter the user programmable pattern.                                              |

&gt;

---

---

**SECTION 13****LOO COD****LOO COD****Set Loop Code Type and Pattern**

|                                 |                                                                                           |
|---------------------------------|-------------------------------------------------------------------------------------------|
| <b>LOO COD?</b>                 | :Displays current T1 loop code type (T1, DDS alternating, and DDS latching) and selection |
| <b>LOO COD DDS_A CHAN+1R</b>    | :Selects DDS alternating CHANNEL loop code with one repeater                              |
| <b>LOO COD DDS_A CHAN+2R</b>    | :Selects DDS alternating CHANNEL loop code with two repeaters                             |
| <b>LOO COD DDS_A 1ST RPTR</b>   | :Selects DDS alternating first repeater loop code                                         |
| <b>LOO COD DDS_A 2ND RPTR</b>   | :Selects DDS alternating second repeater loop code                                        |
| <b>LOO COD DDS_A CHANN</b>      | :Selects DDS alternating CHANNEL loop code                                                |
| <b>LOO COD DDS_A DSU</b>        | :Selects DDS alternating DSU loop code                                                    |
| <b>LOO COD DDS_A HL96</b>       | :Selects DDS alternating HL96NY loop code                                                 |
| <b>LOO COD DDS_A OCU</b>        | :Selects DDS alternating OCU loop code                                                    |
| <b>LOO COD DDS_A OCU+</b>       | :Selects DDS alternating OCU loop code with HL96NY                                        |
| <b>LOO COD DDS_L CHA</b>        | :Selects DDS latching channel loop code                                                   |
| <b>LOO COD DDS_L DS0-DP [x]</b> | :Selects DDS latching DS0-DP loop code and location. [x] equals 1 to 8.                   |
| <b>LOO COD DDS_L LSI</b>        | :Selects DDS latching LSI loop code                                                       |
| <b>LOO COD DDS_L OCU</b>        | :Selects DDS latching OCU loop code                                                       |
| <b>LOO COD T1 CSU</b>           | :Selects T1 in-band CSU loop code                                                         |
| <b>LOO COD T1 ESF-LIN</b>       | :Selects T1 ESF out-of-band Line loop code.                                               |
| <b>LOO COD T1 ESF-NET</b>       | :Selects T1 ESF out-of-band Network loop code.                                            |

LOO COD

LOO COD

## Set Loop Code Type and Pattern (Continued)

|                           |                                                                                                                                                                          |
|---------------------------|--------------------------------------------------------------------------------------------------------------------------------------------------------------------------|
| <b>LOO COD T1 ESF-PAY</b> | :Selects T1 ESF out-of-band Payload loop code                                                                                                                            |
| <b>LOO COD T1 FAC1</b>    | :Selects T1 in-band 4-bit Facility 1 loop code                                                                                                                           |
| <b>LOO COD T1 FAC2</b>    | :Selects T1 in-band 5-bit Facility 2 loop code                                                                                                                           |
| <b>LOO COD T1 PRO</b>     | :Selects T1 in-band Programmable loop code pattern. The loop-up and loop-down codes are programmed through the <b>PGM LPU</b> and <b>PGM LPD</b> commands, respectively. |

**LOO COD** sets the loop-up and loop-down codes that are transmitted when either **LOO U ON** or **LOO D ON** commands are initiated. The T-BERD 224 can also respond to a selected T1 loop code when the **RESP AUT** command is initiated. This command is identical to setting the loop code type and equipment selections with the AUX 17 LOOP CD function. Refer to Table 13-2 for a list of the loop-up and loop-down codes.

See also: **LOO D**, **LOO U**, **RESP**, **PGM LPU**, and **PGM LPD**

## EXAMPLE:

```

>LOO COD? :display current loop code pattern selection
 LOOp CODE T1 CSU
>LOO COD T1 PRO :select T1 programmable loop code
>

```

---

---

**SECTION 13****LOOP D****LOOP D****Transmit Loop-Down Code**

**LOOP D?** :Displays current loop-down code transmission status

**LOOP D ON** :Enables the loop-down code transmission for loopbacks requiring a loop-down code to release the terminal loopback

**LOOP D OFF** :Disables the loop-down code transmission

**LOOP D** controls the transmission of the selected loop-down code which is selected with the **LOOP COD** command. The transmission of the loop-down code continues until it is no longer detected at the receiver or until a **LOOP D OFF** command is issued. This command is identical to pressing the **LOOP DOWN** switch.

See also: **LOOP COD**, **LOOP U**, **RESP**, **PGM LPU**, and **PGM LPD**

**EXAMPLE:**

**>LOOP D?** :display status of loop-down code transmission

**LOOP DOWN OFF**

**>LOOP D ON** :activate loop-down code transmission

**>**

LOO U

LOO U

## Transmit Loop-Up Code

**LOO U?** :Displays current loop-up code status transmission

**LOO U ON** :Enables the loop-up code transmission for loopbacks requiring a loop-up code to initiate the terminal loopback

**LOO U OFF** :Disables the loop-up code transmission

**LOO U** controls the transmission of the selected loop-up code which is selected with the **LOO COD** command. The transmission of the loop-up code continues until it is detected for 250 ms at the receiver or until a **LOO U OFF** command is issued. This command is identical to pressing the **LOOP UP** switch.

See also: **LOO COD**, **LOO D**, **RESP**, **PGM LPU**, and **PGM LPD**

## EXAMPLE:

```
>LOO U? :display status of loop-up code transmission
 LOOp Up OFF
>LOO U ON :activate loop-up code transmission
>
```



---

---

## SECTION 13

**MOD**

**MOD**

### Set Transmit and Receive Mode

**MOD?** :Displays current operating mode

**MOD T1** :Selects the unframed T1 operating mode

**MOD** selects the T-BERD 224 operating mode. Refer to Section 6.5, Remote Control Commands, for additional **MODE** commands. This command is identical to pressing the **MODE** switch and selecting the T1 mode when the **AUX** switch is not illuminated.

**NOTE:** Changing the operating mode causes a test restart and can change the current front panel configuration.

#### EXAMPLE:

> **MOD?** :display status of mode  
MODE T1SLC

> **MOD T1** :set mode to unframed T1

WARNING: New Setup:

MODE T1

CHAnnel FORMat DS0

SOURce 1 BYTe

SOURce 2 10101001

>

NON C

NON C

## Non-Contiguous Channel Selection

NON C?

:Displays current non-contiguous channel selection

NON C L1 [nn] L2 [nn]

:Selects the channel numbers [nn] for LINE 1 and LINE 2. [nn] = 1 to 24. The number of channels must be the same for each line and they must be in ascending order.

**NON C** selects which non-contiguous FT1 channel numbers are tested from each line. Modifying this command causes a test restart if the **SOU 2 NON C** command is set. This command is identical to the AUX 10 N-CONTG function.

EXAMPLE:

&gt; NON C?

:display the non-contiguous channels selected for LINE 1 and LINE 2

LINE 1: 1,2,3,4,5

LINE 2: 3,4,5,6,7

&gt; NON C L1 4,5,6,7,8 L2 5,6,7,8,9

:select the non-contiguous channels for LINE 1 (4, 5, 6, 7, and 8) and for LINE 2 (5, 6, 7, 8, and 9)

&gt;

---

---

**SECTION 13****PGM LPD****PGM LPD****Set Programmable Loop-Down Code**

**PGM LPD?** :Displays current in-band programmable loop-down code

**PGM LPD (bb...bb)** :Sets in-band programmable loop-down code. (bb...bb) equals 3- to 8-bit binary code. The left-most bit is transmitted first.

**PGM LPD** enables a 3- to 8-bit user programmable in-band loop-down code to be entered. The programmable loop-down code is selected through the **LOO COD T1 PRO** command and transmitted when the **LOO D ON** command is initiated. **PGM LPD** also determines which loop code the T-BERD 224 responds to (see **RESP** command) when the **LOO COD T1 PRO** command is set. This command is identical to setting the in-band programmable loop-down code with the **AUX 16 PGM LP, DOWN**, function.

See also: **LOO COD, LOO D, LOO U, RESP, and PGM LPU**

**EXAMPLE:**

**>PGM LPD?** :display current programmable loop-down code

PGM LPDn 01001001

**>PGM LPD 100** :set programmable loop-down code to 100

**>**

PGM LPU

PGM LPU

## Set Programmable Loop-Up Code

**PGM LPU?** :Displays current in-band programmable loop-up code

**PGM LPU (bb...bb)** :Sets in-band programmable loop-up code. (bb...bb) equals 3- to 8-bit binary code. The left-most bit is transmitted first.

**PGM LPU** enables a 3- to 8-bit user programmable in-band loop-up code to be entered. The programmable loop-up code is selected through the **LOO COD** command and transmitted when the **LOO U ON** command is initiated. **PGM LPU** also determines which loop code the T-BERD 224 responds to (see **RESP** command) when the **LOO COD T1 PRO** command is set. This command is identical to setting the in-band programmable loop-up code with the AUX 16 PGM LP, UP, function.

See also: **LOO COD**, **LOO D**, **LOO U**, **RESP**, and **PGM LPD**

## EXAMPLE:

```
>PGM LPU? :display current programmable loop-up code
 PGM LPUp 01001001
>PGM LPU 100 :set programmable loop-up code to 100
>
```

---

---

## SECTION 13

**PRI**

**PRI**

Initiate Printout

**PRI CON** :Initiates a controls printout

**PRI RES** :Initiates a results printout

**PRI [result name]?** :Initiates a results printout by **[result name]**

The following valid **[result names]** are available with the BERT Option:

| Valid Result Names | Displayed Result |
|--------------------|------------------|
| <b>BIT ERn</b>     | n00 BIT ERR      |
| <b>ASY ESn</b>     | n01 ASYN ER      |
| <b>BERn</b>        | n04 BER          |
| <b>EFSn</b>        | n05 EFS          |
| <b>% EFSn</b>      | n06 % EFS        |
| <b>SYN ESn</b>     | n07 SYN ES       |
| <b>OOS SE n</b>    | n08 OOS SEC      |
| <b>PAT SLn</b>     | n09 PAT SLP      |
| <b>SPX CRn</b>     | n50 SPX CUR      |
| <b>DELAYn</b>      | n53 DELAY        |
| <b>RCV BYTn</b>    | n80 RCV BYT      |
| <b>RCV CODn</b>    | n95 RCODE        |
| <b>DDS F En</b>    | n96 DDS F E      |
| <b>%IN SRVn</b>    | n98 % IN SRV     |

“n” = 1 or 2. Refer to Section 6.5, Remote Control Commands, for additional **PRI** results.

See also: **CONTROLS** and **RESULTS**

EXAMPLE:

```
> PRI BPV1? :print the BPV result for LINE 1
 BPV1 12345 :12345 BPVs are detected on LINE 1
```

>

RES 1 and 2

RES 1 and 2

## Result Display Control

|                        |                                                                                              |
|------------------------|----------------------------------------------------------------------------------------------|
| <b>RES [1 2]?</b>      | :Prints the displayed result in the Results I or II display                                  |
| <b>RES 1 [result]n</b> | :Display the indicated <b>[result]</b> in Results I display. <b>n</b> = LINE "1" or LINE "2" |
| <b>RES 2 [result]n</b> | :Display the indicated <b>[result]</b> in Results II display                                 |

**RES** controls the displayed results in the Results I and II displays. Unlike the **PRINT** command, the **RES** command calls up the specified results in the Results displays. The specified result is not displayed at the remote control unit, unless **RES [1|2]?** is used. Replace **[result]n** with one of the following results:

| Valid Result Names | Displayed Result |
|--------------------|------------------|
| <b>BIT ERn</b>     | n00 BIT ERR      |
| <b>ASY ESn</b>     | n01 ASYN ER      |
| <b>BERn</b>        | n04 BER          |
| <b>EFSn</b>        | n05 EFS          |
| <b>% EFSn</b>      | n06 % EFS        |
| <b>SYN ESn</b>     | n07 SYN ES       |
| <b>OOS SEn</b>     | n08 OOS SEC      |
| <b>PAT SLn</b>     | n09 PAT SLP      |
| <b>SPX CRn</b>     | n50 SPX CUR      |
| <b>DELAYn</b>      | n53 DELAY        |
| <b>RCV BYTn</b>    | n80 RCV BYT      |
| <b>RCV CODn</b>    | n95 RCODE        |
| <b>DDS F En</b>    | n96 DDS F E      |
| <b>%IN SRVn</b>    | n98 % IN SRV     |

**UNAVAIL** appears as the result when frame synchronization is not established. **N/A** appears as the result before establishing frame synchronization or command is not applicable to current configuration. Refer to Section 6.5, Remote Control Commands, for additional **RES** results.

See also: **CHA FOR**, **MOD**, and **PRI**

---

---

**SECTION 13**

**RES 1 and 2**

**RES 1 and 2**

**Result Display Control (Continued)**

**EXAMPLE:**

```
> RES 1 BIT ER1 :display the bit error count (100 BIT ERR) for
 LINE 1 in the Results I display
> RES 1? :print the current result in the Results I display
 BIT ER1: 3920349
>
```

**RESP****RESP**

## Set Automatic T1 Loop Code Response

- RESP?** :Displays current T1 loop code response status
- RESP A** :Enables the automatic T1 loop code response
- RESP N** :Disables the automatic T1 loop code response

**RESP** controls how the T-BERD 224 responds to T1 loop codes selected through the **LOO COD T1** command. If five seconds of T1 in-band loop-up code are received, the T-BERD 224 automatically enters the AUTO LLB mode; the instrument repeats all transmitted data until a valid loop-down code is received. After receiving a loop-down code, the T-BERD 224 exits AUTO LLB mode and reenters the previously selected operating mode indicated by the current setting of the **MODE** switch (or **MOD** command). This command is identical to setting the automatic loop code response with the AUX 18 AUT RES function.

See also: **LOO D**, **LOO U**, **LOO COD**, **PGM LPU**, and **PGM LPD**

## EXAMPLE:

- >RESP?** :display current loop code response status  
RESPonse NOne
- >RESP A** :set automatic loop code response
- >**



**Set Source Configuration I**

**SOU 1?** :Displays the current source configuration I selection which is equivalent to pressing the **SCI** switch

**SOU 1 (parameter)** :Sets the source configuration I (**parameter**)

**SOU 1** selects the drop and insert source which is to be used when analyzing the selected channel(s). The following valid (**parameters**) are available with the BERT Option:

|                   |                                          |
|-------------------|------------------------------------------|
| <b>1:7</b>        | A One and Seven Zeros Pattern            |
| <b>2^15-1</b>     | 32,767-Bit Pseudorandom Pattern          |
| <b>2^15-1 INV</b> | Inverted 32,767-Bit Pseudorandom Pattern |
| <b>2^20-1</b>     | 1,048,575-Bit Pseudorandom Pattern       |
| <b>2^23-1</b>     | 8,388,607-Bit Pseudorandom Pattern       |
| <b>3 IN 24</b>    | Three Ones In 24-Bits Pattern            |
| <b>63</b>         | 63-Bit Pseudorandom Pattern              |
| <b>511</b>        | 511-Bit Pseudorandom Pattern             |
| <b>2047</b>       | 2047-Bit Pseudorandom Pattern            |
| <b>ALL ONE</b>    | All Ones Pattern                         |
| <b>ALL ZER</b>    | All Zeros Pattern                        |
| <b>AUTO</b>       | Automatic Pattern Search                 |
| <b>DDS1</b>       | DDS 1 Stress Pattern                     |
| <b>DDS2</b>       | DDS 2 Stress Pattern                     |
| <b>DDS3</b>       | DDS 3 Stress Pattern                     |
| <b>DDS4</b>       | DDS 4 Stress Pattern                     |
| <b>GRS</b>        | Quasi-Random Signal Source Pattern       |
| <b>MIN/</b>       | Minimum/Maximum Density Stress Pattern   |
| <b>USE</b>        | User Programmable Bit Pattern            |

Refer to Section 6.5, Remote Control Commands, for additional **SOU 1** results. This command is identical to pressing the **SCI** switch when the **AUX** switch is not illuminated.

**SOU 1****SOU 1****Set Source Configuration I (Continued)**

**NOTE:** Changing the source configuration causes a test restart and can change the current front panel configuration.

**EXAMPLE:**

**> SOU 1?** :display the current source configuration I selection

SOURce 1 DDS1

**> SOU 1 QRS** :select the quasi-random signal source pattern as the new source configuration

**WARNING:** New Setup:

MODE T1D4

CHAnnel FORMat DS0

SOURce 1 QRSS

SOURce 2

**>**

**SOU 2****SOU 2****Set Source Configuration II**

**SOU 2?** :Displays the current status for the **SCII** switch selection

**SOU 2 CHA [x]** :Selects the DS0B channel format subrate channel number [x]. [x] = 1 to 20 for DS0B2.4, 1 to 10 for DS0B4.8, or 1 to 5 for DS0B9.6. This is only valid for **CHA FOR** parameters DS0B2.4, DS0B4.8, and DS0B9.6.

**SOU 2 N=[1 to 24]** :selects the number of DS0 channels [x] for testing contiguous FT1 channels. This is only valid for **CHA FOR** parameters 56XN and 64XN.

**SOU 2 NON C** :selects non-contiguous FT1 channel format entered with the **NON C** command. This is only valid for **CHA FOR** parameters 56XN and 64XN.

**SOU 2** augments the **SOU 1** command selections for the DS0B and FT1 channel formats. Selects or returns the drop and insert source which is used when analyzing the selected channels. Modifying this command causes a test restart.

**EXAMPLE:**

> **SOU 2?** :display the current SCII selection

SOURce 2 CHAnnel 5

> **SOU 2 CHA 10** :change the channel number to 10

WARNING: New Setup:

MODE T1D4

CHAnnel FORmat DS0B4.8

SOURce 1 2047

SOURce 2 CHAnnel 10

>

**USE****USE****Set User Programmable Test Pattern****USE?**

:Displays current user programmable data pattern

**USE (bb...bb)**:Sets the user programmable data pattern. **(bb...bb)** equals 3- to 24-bit binary code. The left-most bit is transmitted first.

**USE** enables a 3- to 24-bit user programmable test pattern to be entered. The test pattern is selected through the **SCI** switch. This command is identical to setting the user programmable pattern with the AUX 15 USER function.

See also: **SOU 1 USE****EXAMPLE:**

```

>USE? :display current user pattern
 USER 10000100 :8-bit test pattern
>USE 10101110000111010 :enter new test pattern
>

```

## **13.9 SPECIFICATIONS**

The following specifications only relate to features and capabilities of the BERT Option.

### **13.9.1 Front Panel Switches**

- Modes: T1 and AUTO.
- Channel formats: FULL T1, DS0A2.4, DS0A4.8, DS0A9.6, DS019.2, DS0A56, DS064, DS0B2.4, DS0B4.8, DS0B9.6, 56xN, 64xN, and ESF datalink.
- Source Configuration I patterns:
  - Fixed - ALL ONES, 1:7, 3 IN 24, MIN/MAX, programmable 3- to 24-bit pattern, ALL ZERO, DDS1, DDS2, DDS3, and DDS4.
  - Pseudorandom - QRSS, 63, 511, 2047, 2<sup>15</sup>-1, 2<sup>15</sup>-1 INV, 2<sup>20</sup>-1, and 2<sup>23</sup>-1.
  - Automatic pattern search (AUTO).
- Results:
  - SUMMARY - Bit error result, pattern slip result, not B8ZS compatible message, and ones density violation message.
  - LOGIC - Bit errors, asynchronous errored seconds, bit error rate, error-free seconds, percent error-free seconds, synchronized errored seconds, out-of-synchronization seconds, and pattern slips.
  - SIGNAL - Simplex current and round trip delay.
  - CHANNEL - Reportable DS0 control code byte, reportable DS0 control code, DDS frame errors, and percent of in-service secondary bits.

TIME - Alarm second result includes ones density violation count.

- **Error Insert:**
  - BPV - single, continuous error rate, or burst. Error rate range 1.0 E-2 to 9.9 E-9. Burst length range 20 ms to 5 sec. with selected error rate.
  - Logic - single, continuous error rate, or burst. Error rate range 1.0 E-2 to 9.9 E-9. Burst length range 20 ms to 5 sec. with selected error rate.
  - Frame - single, 2 to 6 consecutive frame errors, or continuous 1 to 6 consecutive frame errors per superframe. Error insertion on Ft bits for D4 or SLC-96 framing; FPS bits for ESF framing; or F-bit for ZBTSE encoded ESF.

### **13.9.2 Indicators**

- **Alarm Indicators:** LINE 1 and LINE 2 pattern synchronization and loss of pattern synchronization.
- **Error Insert Indicators:** Frame Error Insert, BPV Error Insert, Logic Error Insert. Single flash for single error insertion, three flashes for burst error insertion, and illuminated continuously for continuous error insertion.

### **13.9.3 Indicator Alarm Criteria**

- **Pattern Sync Loss:** 250 or more errors detected in 1000 or fewer bits.

### **13.9.4 Pattern Definition**

- **1:7:** F01000000... Pattern is aligned with framing (F) patterns as indicated.
- **2<sup>15</sup>-1:** 2<sup>15</sup>-1 bit pseudorandom.

---

---

## SECTION 13

- $2^{15}-1$  INV: Inverted  $2^{15}-1$  bit pseudorandom.
- $2^{20}-1$ :  $2^{20}-1$  bit pseudorandom.
- $2^{23}-1$ :  $2^{23}-1$  bit pseudorandom.
- 3 IN 24: F0100 0100 0000 0000 0000 0100... Pattern is aligned with framing (F) patterns as indicated.
- 63:  $2^6-1$  bit pseudorandom.
- 511:  $2^9-1$  bit pseudorandom.
- 2047:  $2^{11}-1$  bit pseudorandom.
- ALL ONES: All Ones (Marks).
- ALL ZERO: AMI coding - all zeros, no pulses except framing.  
B8ZS coding - B8ZS BPV sequence 000V 10V1 (V = bipolar violation)  
ZBTSI coding - stresses the ZBTSI encoding algorithm.
- DDS1 200 octet minimum/maximum ones density.
- DDS2 200 octet minimum ones density.
- DDS3 Single octet with medium ones density.
- DDS4 Single octet with low ones density.
- QRSS: QRSS pattern ( $2^{20}-1$  with zero suppression).
- USER: 3- to 24-bit programmable pattern. Factory default: 10000.
- MIN/MAX Minimum/Maximum ones and zeros density stress pattern (see Appendix D).

### 13.9.5 Pattern Sync Detection Criteria

- **Fixed Patterns:** 30 consecutive error-free bits (ALL ONES, 1:7, 3 IN 24, programmable 3- to 24-bit pattern, ALL ZERO, DDS3, and DDS4).
- **DDS1 and DDS2:** 800 consecutive error-free bits.
- **MIN/MAX:** 220 consecutive error-free bits.
- **Pseudorandom Patterns:**  $30 + n$  consecutive error-free bits for a pattern length of  $2^n - 1$ . For QRSS,  $n = 20$  (QRSS, 63, 511, 2047,  $2^{15} - 1$ ,  $2^{15} - 1$  INV,  $2^{20} - 1$ , and  $2^{23} - 1$ ).

### 13.9.6 Loop Code Generation and Detection Patterns

- **In-band Loop Codes:**
  - CSU** - loop up: 10000; loop down: 100.
  - Facility 1** - loop up: 1100; loop down: 1110.
  - Facility 2** - loop up: 11000; loop down: 11100.
  - Programmable** - 3- to 8-bit repeating code independently selectable for loop-up and loop-down codes. Factory default: loop up - 10000 (CSU loop-up); loop down - 100 (CSU loop-down).
- **ESF Out-of-Band Loop Codes:**
  - LINE** - loop up: 1111 1111 0111 0000; loop down: 1111 1111 0001 1100.
  - PAYLOAD** - loop up: 1111 1111 0010 1000; loop down: 1111 1111 0100 1100.
  - NETWORK** - loop up: 1111 1111 0100 1000; loop down: 1111 1111 0010 0100.

**NOTE:** Generated codes may be sent unframed or framed. When framing is selected, in-band loop codes are overwritten by the framing bit.



---

---

## **SECTION 13**

### **13.9.7 Loop Code Detection Criteria**

- In-band Loop Codes: At least 177 error-free bits of the selected repetitive pattern must be received (Loop Up and Loop Down).
- ESF Out-of-Band Loop Codes: Datalink monitored every 125 ms for loop codes (Loop up and Loop down).

### **13.9.8 Simplex Current**

- Range: 0 mA to 250 mA.
- Resolution: 2 mA.
- Accuracy:  $\pm 2$  mA.
- Simplex Voltage Drop: 8.5 volts (nominal) at 60 mA.

## VF OPTION

### 14.1 INTRODUCTION

This section describes the features, functional operation, and specifications of the VF Option when it is installed in the T-BERD 224 PCM Analyzer.

#### 14.1.1 Standard Features

The T-BERD 224 VF Option provides the following standard features and capabilities:

- Measures received VF Level in dBm.
- Measures Echo Return Loss (ERL) and Singing Return Loss (SRL-HI and SRL-LO).
- Measures C-message noise and C-notch noise for qualifying voice-grade communications.
- Measures 3 kHz flat noise and 3 kHz notch noise for qualifying analog data-grade circuits.
- Computes signal-to-noise ratio (S/N Ratio).
- Measures DC offset.
- Determines Peak-to-Average Ratio (P/AR).
- Generates and transmits a VF frequency tone from 20 Hz to 3904 Hz with a default frequency of 1004 Hz.
- Adjusts the VF frequency tone level from -40.0 dBm to +3.0 dBm with a default level of -10.0 dBm.
- Provides a VF burst (VFBURST) to disable the echo canceller prior to a return loss measurement.

---

## SECTION 14

- Automatically sweeps through a user-defined range of frequencies for analyzing frequency response of an analog circuit.

### 14.1.2 Optional Features

The following T-BERD 224 options are available and can be used with the VF Option (Model 41502) installed:

**ZBTSI Framing Option (Model 11425)** — This option allows the T-BERD 224 to test and analyze T1 ESF (Extended Superframe) circuits that use ZBTSI encoding. Refer to Section 11, ZBTSI Framing Option, for additional information.

**DSU-DP Option (Model 41441)** — This option adds an EIA RS-232-C and either an EIA RS-449 or CCITT V.35 drop and insert interface for external testing of unformatted fractional T1, DSOA, DSOB, and ESF and ESFz data link signals. Refer to Section 12, DSU-DP Option, for additional information.

**T1/Fractional T1/DDS BERT Option (Model 41500)** — This option enables the T-BERD 224 to perform out-of-service bit error rate tests on T1, fractional T1, and DDS circuits with 17 different test patterns; test both DSOA and DSOB formatted DDS circuits; test both DDS PRIMARY and SECONDARY channels; emulate a T1 CSU by terminating the T1 span and auto-responding to T1 loop codes; measure simplex current and round trip delay, transmit in-band and out-of-band (ESF) loop codes; send both alternating and latching DDS loop codes for sectionalizing and troubleshooting DDS circuits; and insert single, burst, or continuous logic, BPV, and frame errors). Refer to Section 13, Bit Error Rate Test Option, for a full description of the BERT Option.

**Enhanced ESF/SLC-96 Option (Model 11704)** — This option enables the T-BERD 224 to monitor and transmit T1.403 performance report messages (PRMs) on ESF and ESFz framed circuits; monitor major, minor, power, and miscellaneous alarms; detect protection switches and maintenance activity on SLC-96 framed circuits; and send major, minor, and power alarms, as well as perform far-end loops on SLC-96 framed circuits. Refer to Section 15, Enhanced SLC-96 and ESF Option, for additional information.

For ordering information on these optional features, refer to Section 9, Options and Accessories. For more detailed descriptions of these optional features refer to the indicated sections.

## 14.2 FUNCTIONAL DESCRIPTION

The T-BERD 224 VF Option enables the user to test a single analog voice-grade or data-grade circuit at a T1 access point, such as a DSX-1 cross-connect without disrupting the remaining 23 channels. With the VF Option installed, the T-BERD 224 can transmit and receive VF tones, and it can analyze received VF signals for VF frequency, level, voice-grade noise, data-grade noise, signal-to-noise ratio (S/N), return loss values, and peak-to-average ratio (P/AR). The user can also perform tests at various set tones (Three Tone Slope test) or across a band of frequencies (Automated Sweep test) that reflect the VF channel's frequency response.

**NOTE:** The T-BERD 224 performs all measurements at a T1 access point.

The **SOURCE CONFIGURATION I (SCI)** switch selects the VF test to be performed, while the **SOURCE CONFIGURATION II (SCII)** switch is used to select additional parameters required to perform a selected test. All VF results are displayed in the CHANNEL category. Two results may be viewed simultaneously by selecting CHANNEL with both the **RESULTS I** and **RESULTS II Category** switches and scrolling to different results (e.g., 181 VF FREQ and 182 VF LVL) with the **RESULTS I** and **RESULTS II Results** switches.

Additional auxiliary functions are included with the VF Option when additional test parameters need to be entered. These additional auxiliary functions may be accessed by pressing the AUX switch just as with the T-BERD 224 Mainframe.

## 14.3 CONTROLS AND INDICATORS

The following controls and indicators are affected by the VF Option. Unless otherwise indicated, the switch information described in Section 2, Instrument Description, also applies. See Table 14-1 for the T-BERD 224 switch configurations added by the VF Option.

- **AUX** switch
- **SCI** switch
- **SCII** switch
- **RESULTS I** switches
- **RESULTS II** switches

Table 14-1  
VF Option Switch Configuration

| Switch/Aux Function | Configuration                                                          |                   |                    |        |         |                              |
|---------------------|------------------------------------------------------------------------|-------------------|--------------------|--------|---------|------------------------------|
|                     | T1-D1D, T1-D2, T1-D4, T1-ESF, T1-ESFz, T1-SLC-96, T1-TLB, T1-LLB, AUTO |                   | VF or VF THRU      |        |         |                              |
| MODE                |                                                                        |                   |                    |        |         |                              |
| CHANNEL FORMAT      |                                                                        |                   |                    |        |         |                              |
| SCI                 | FREQ                                                                   | LEVEL SWEEP       | ERL SRL-HI         | PAR    | 2713 Hz | 3-TONE SLOPE                 |
| SCII                | 20 Hz to 3704 Hz                                                       | -40.0 to +3.0 dBm | fixed at -10.0 dBm | SRL-LO | ON/OFF  | 404 Hz<br>1004 Hz<br>2804 Hz |
| AUX 21 SWEEP        |                                                                        | X*                |                    |        |         |                              |
| AUX 22 VFBURST      |                                                                        |                   | X                  |        |         |                              |
| AUX 23 PRT OPT      | X                                                                      | X                 |                    |        | X       | X                            |

\*AUX 21 SWEEP only applies to the **SCI** switch's SWEEP position.  
See Appendix E for fully optioned T-BERD 224.

### 14.3.1 AUX Switch

The following additional Auxiliary functions are available with the VF option:

- **AUX 21 SWEEP** — Set the Frequency Sweep END-POINT (START/STOP), STEP characteristics (STEP-SIZE/STEP-INTVL), and SKIP frequencies (SKIP-HI/SKIP-LO).
- **AUX 22 VFBURST** — Set the VF Burst parameters (ON/OFF, FREQ, and LEVEL) to disable echo cancellers.
- **AUX 23 PRT OPT** — Control the Frequency Sweep (FREQ SWP) printout of Frequency vs. Level (ON/OFF).

Refer to Section 14.4, Auxiliary Functions, for descriptions of the Auxiliary functions.

### 14.3.2 SOURCE CONFIGURATION I Switch

The following additional source configuration selections are available when the switch is pressed:

- **FREQUENCY (FREQ)** — Transmits a single tone (default value of 1004 Hz) at an output level set in the Level source configuration. The **SCII** switch is used to modify the frequency of the transmitted tone from 20 Hz to 3904 Hz.
- **LEVEL (LEVEL)** — Selects a transmit level (default value of -10.0 dBm) for the tone generated by the FREQUENCY function. The **SCII** switch is used to modify the level of the transmitted frequency from -40.0 dBm to +3.0 dBm in 0.1 dBm increments. By holding the **SCII** switch down, the T-BERD 224 automatically scrolls through the levels.
- **FREQUENCY SWEEP (SWEEP)** — Automatically steps through a user-selected range of frequencies. This test is used to analyze attenuation distortion and frequency response on a VF circuit 0.5 seconds after the selection is made if INSERT is selected. The **SCII** switch is used to modify the level of the transmitted frequencies from -40.0 dBm to +3.0 dBm. The frequency sweep parameters are

---

## SECTION 14

set in AUX 21 SWEEP; a message stating this is displayed for 2 seconds after the SWEEP function is selected (see Appendix C, Operating Messages). If the user presses the **AUX** switch when SWEEP is selected, AUX 21 SWEEP is immediately displayed.

**NOTE:** Changing the level setting for the frequency sweep function will also affect the basic VF Level setting and vice versa.

- **PEAK TO AVERAGE RATIO (PAR)** — Transmits a complex waveform with a spectral content consisting of 16 non-harmonically related tones, with a known envelope shape that approximates a data signal. This test measures the combined effects of group delay, amplitude distortion, and return loss on a VF circuit. The **SCII** switch is used to modify the level of the transmitted frequency from -40.0 dBm to -10.0 dBm with a default level of -13.0 dBm.
- **ECHO RETURN LOSS (ERL)** — Transmits a band limited noise to measure return loss on VF circuits. The transmit level for return loss signals is fixed at -10.0 dBm. Pressing the **SCII** switch will display “ONLY SELECTION AVAILABLE” in the second window. Once ERL is selected, the message “SET BURST FREQ IN AUX 22” is displayed (see Appendix C, Operating Messages). If VF burst is ON, the previous parameters for burst frequency and burst level will be used to transmit a tone to disable any echo cancellers. If the user presses the **AUX** switch with ERL selected, AUX 22 VFBURST is immediately displayed.
- **SINGING RETURN LOSS - HIGH (SRL-HI)** — Transmits band limited noise to simulate high frequency voice-grade operation and measure the return loss. The level for return loss signals is fixed at -10.0 dBm. Pressing the **SCII** switch will display “ONLY SELECTION AVAILABLE” in the second window. Once SRL-HI is selected, the message “SET BURST FREQ IN AUX 22” is displayed (see Appendix C, Operating Messages). If VF burst is ON, the previous parameters for burst frequency and burst level will be used to transmit a tone to disable any echo cancellers. If the user presses the **AUX** switch with SRL-HI selected, AUX 22 VFBURST is immediately displayed.
- **SINGING RETURN LOSS - LOW (SRL-LO)** — Transmits band limited noise to simulate voice-grade operation and measure return loss. The level for return loss signals is fixed at -10.0 dBm. Once

SRL-LO is selected, the message “SET BURST FREQ IN AUX 22” is displayed (see Appendix C, Operating Messages). If VF burst is ON, the previous parameters for burst frequency and burst level will be used to transmit a tone to disable the echo canceller on the line. If the user presses the **AUX** switch when SRL-LO is selected, AUX 22 VFBURST is immediately displayed.

- **3-TONE SLOPE** — Transmits one of three frequencies at an output level set in the level source configuration. This test is used to obtain a quick measure of a channel’s amplitude distortion. The **SCII** switch is used to select the transmitted frequency (404 Hz, 1004 Hz, or 2804 Hz).
- **2713** — Transmits a 2713 Hz tone at an output level set in the level source configuration. This test is used to loop 813 devices on 4-wire VF circuits. The **SCII** switch is used to turn this feature on or off.
- **QUIET** — Transmits an idle code. This position is used to ensure no traffic is on the VF circuit.

Refer to Section 14.5, Measurements, for descriptions of the listed VF measurements.

### 14.3.3 **RESULTS I and II Switches**

The CHANNEL category contains all VF test results. The results include VF level (VF LVL), VF frequency (VF FREQ), DC offset (DC-OFF), signal-to-noise ratio (S/N), C-Notch noise (C-NCH), C-Message noise (C-MSG), 3 kHz Notch noise (3K NCH), 3 kHz flat noise (3K FLAT), peak-to-average ratio (P/AR and PAR LV), echo return loss (ERL), and singing return loss (SRL-HI and SRL-LO). Refer to Section 14.5, Measurements, for additional information.

## 14.4 **AUXILIARY FUNCTIONS**

This section lists the VF auxiliary functions and describes each function, including an example of the auxiliary function display. The auxiliary functions are accessed with the **AUX** switch. Refer to Appendix A for a list of the default settings.



---

---

## SECTION 14

**NOTE:** Many auxiliary functions are only accessible when a particular test is selected. This feature limits the amount of scrolling necessary to find specific auxiliary functions. Refer to Appendix A for a list of default settings.

### 14.4.1 AUX 21 SWEEP — Set Frequency Sweep Parameters

|                          |                          |                          |                          |                          |                          |                          |                          |
|--------------------------|--------------------------|--------------------------|--------------------------|--------------------------|--------------------------|--------------------------|--------------------------|
| <b>AUX 21<br/>SWEEP</b>  | <b>*END-POINT</b>        | <b>START<br/>100 Hz</b>  | <b>STOP<br/>2500 Hz</b>  |                          |                          |                          |                          |
| MODE                     | CHANNEL<br>FORMAT        | SCI                      | SCII                     | RESULTS I                | RESULTS II               |                          |                          |
| <input type="checkbox"/> | <input type="checkbox"/> | <input type="checkbox"/> | <input type="checkbox"/> | <input type="checkbox"/> | <input type="checkbox"/> | <input type="checkbox"/> | <input type="checkbox"/> |

\* Indicates that this is one of three possible AUX 21 SWEEP parameter screens. STEP and SKIP are the other two parameter screens.

AUX 21 SWEEP allows the user to set the Frequency Sweep parameters when SWEEP is selected with the **SCI** switch. The auxiliary function is controlled by the following switches:

**SCI** switch — The **SCI** switch selects one of the three displayed parameters, **END-POINT**, **STEP**, or **SKIP**, as follows:

- **END-POINT** enables users to set the start and stop frequencies (**START** and **STOP**) for the frequency band to be monitored.
- **STEP** selects the step size and time spent at each frequency (**STEP-SIZE** and **STEP-INTVL**).
- **SKIP** allows the user to set a portion of the frequency band that will not be tested to avoid unintentional transmission of frequency tones that can be interpreted as loopback codes. The skip interval is determined by establishing high and low skip frequencies (**SKIP-HI** and **SKIP-LO**).

|                 |            |                 |                 |
|-----------------|------------|-----------------|-----------------|
| AUX 21<br>SWEEP | *END-POINT | START<br>100 Hz | STOP<br>2500 Hz |
|-----------------|------------|-----------------|-----------------|

|                          |                          |                          |                          |                                                   |                                                   |
|--------------------------|--------------------------|--------------------------|--------------------------|---------------------------------------------------|---------------------------------------------------|
| MODE                     | CHANNEL<br>FORMAT        | SCI                      | SCII                     | RESULTS I                                         | RESULTS II                                        |
| <input type="checkbox"/> | <input type="checkbox"/> | <input type="checkbox"/> | <input type="checkbox"/> | <input type="checkbox"/> <input type="checkbox"/> | <input type="checkbox"/> <input type="checkbox"/> |

**RESULTS I Category** switch — When the END-POINT parameter screen is displayed, this switch modifies the START frequency from 20 Hz to 3904 Hz with a default value of 104 Hz.

**RESULTS II Results** switch — When the END-POINT parameter screen is displayed, this switch modifies the STOP frequency from 20 Hz to 3904 Hz with a default value of 3704 Hz.

|                 |      |                     |                        |
|-----------------|------|---------------------|------------------------|
| AUX 21<br>SWEEP | STEP | STEP-SIZE<br>100 Hz | STEP-INTVL<br>2.0 SECS |
|-----------------|------|---------------------|------------------------|

|                          |                          |                          |                          |                                                   |                                                   |
|--------------------------|--------------------------|--------------------------|--------------------------|---------------------------------------------------|---------------------------------------------------|
| MODE                     | CHANNEL<br>FORMAT        | SCI                      | SCII                     | RESULTS I                                         | RESULTS II                                        |
| <input type="checkbox"/> | <input type="checkbox"/> | <input type="checkbox"/> | <input type="checkbox"/> | <input type="checkbox"/> <input type="checkbox"/> | <input type="checkbox"/> <input type="checkbox"/> |

**RESULTS I Category** switch — When the STEP parameter screen is displayed, this switch modifies the STEP-SIZE frequency from 10 Hz to 1000 Hz with a default value of 100 Hz.

**RESULTS II Results** switch — When the STEP parameter screen is displayed, this switch modifies the STEP-INTVL (Frequency Step Interval) from 1.5 seconds to 9.9 seconds with a default value of 2 seconds.

## SECTION 14

|                               |             |                           |                           |
|-------------------------------|-------------|---------------------------|---------------------------|
| <b>AUX 21</b><br><b>SWEEP</b> | <b>SKIP</b> | <b>SKIP-HI</b><br>2750 Hz | <b>SKIP-LO</b><br>2450 Hz |
|-------------------------------|-------------|---------------------------|---------------------------|

|                          |                          |                          |                          |                                                   |                                                   |
|--------------------------|--------------------------|--------------------------|--------------------------|---------------------------------------------------|---------------------------------------------------|
| MODE                     | CHANNEL<br>FORMAT        | SCI                      | SCII                     | RESULTS I                                         | RESULTS II                                        |
| <input type="checkbox"/> | <input type="checkbox"/> | <input type="checkbox"/> | <input type="checkbox"/> | <input type="checkbox"/> <input type="checkbox"/> | <input type="checkbox"/> <input type="checkbox"/> |

**RESULTS I Category** switch — When the SKIP parameter screen is displayed, this switch modifies the SKIP-HI frequency from 20 Hz to 3904 Hz with a default of 2750 Hz. This value should always be set higher than the SKIP-LO frequency.

**RESULTS II Results** switch — When the SKIP parameter screen is displayed, this switch modifies the SKIP-LO frequency from 20 Hz to 3904 Hz with a default of 2450 Hz. This value should always be set lower than the SKIP-HI frequency.

### 14.4.2 AUX 22 VFBURST — Set Voice Frequency Burst Parameters

|                                 |                    |                        |                           |
|---------------------------------|--------------------|------------------------|---------------------------|
| <b>AUX 22</b><br><b>VFBURST</b> | <b>BURST</b><br>ON | <b>FREQ</b><br>2125 Hz | <b>LEVEL</b><br>-10.0 dBm |
|---------------------------------|--------------------|------------------------|---------------------------|

|                          |                          |                          |                          |                                                   |                                                   |
|--------------------------|--------------------------|--------------------------|--------------------------|---------------------------------------------------|---------------------------------------------------|
| MODE                     | CHANNEL<br>FORMAT        | SCI                      | SCII                     | RESULTS I                                         | RESULTS II                                        |
| <input type="checkbox"/> | <input type="checkbox"/> | <input type="checkbox"/> | <input type="checkbox"/> | <input type="checkbox"/> <input type="checkbox"/> | <input type="checkbox"/> <input type="checkbox"/> |

VF BURST allows the user to set the frequency and level of the VF burst function. The burst is used before a return loss measurement to disable the echo canceller on the channel. The duration of a burst is 2700 milliseconds. The auxiliary function is controlled by the following switches:

**SC II** switch — Press the **SCII** switch to toggle between burst ON and burst OFF with a default value of OFF.

**RESULTS I Category switch** — Press the **RESULTS I Category** switch to set the burst frequency parameter from 20 Hz to 3904 Hz with a default value of 2125 Hz

**RESULTS II Results switch** — Press the **RESULTS II Results** switch to set the burst level parameter from -40.0 dBm to +3.0 dBm with a default value of -10.0 dBm.

#### 14.4.3 AUX 23 PRT OPT — Frequency Sweep Print Option

|                          |                          |                          |                          |                          |                          |                          |                          |
|--------------------------|--------------------------|--------------------------|--------------------------|--------------------------|--------------------------|--------------------------|--------------------------|
| <b>AUX 23</b>            |                          | <b>FREQ SWP</b>          |                          |                          |                          |                          |                          |
| <b>PRT OPT</b>           |                          | <b>ON</b>                |                          |                          |                          |                          |                          |
| CHANNEL                  |                          | SCI                      |                          | RESULTS I                |                          | RESULTS II               |                          |
| MODE                     | FORMAT                   | SCI                      | SCII                     |                          |                          |                          |                          |
| <input type="checkbox"/> | <input type="checkbox"/> | <input type="checkbox"/> | <input type="checkbox"/> | <input type="checkbox"/> | <input type="checkbox"/> | <input type="checkbox"/> | <input type="checkbox"/> |

PRT OPT (Print Option) allows the user to toggle the Frequency Sweep printout ON or OFF. When SWEEP, 3-TONE SLOPE, 2713, QUIET, FREQ, or LEVEL are selected by the **SCI** switch, the T-BERD 224 generates a frequency vs. level chart (see Figure 14-1) if PRT OPT is ON. The auxiliary function is controlled by the following switch:

**SCII switch** — Press the **SCII** switch to set the Frequency Sweep print-out ON or OFF with a default value of OFF.

|                     |           |          |           |        |  |
|---------------------|-----------|----------|-----------|--------|--|
| RX FREQ SWEEP PRINT |           | 05:32:38 |           | DEC 12 |  |
| Frequency           |           | Level    |           |        |  |
| 204 HZ              | -25.0 DBM | 304 HZ   | -16.5 DBM | . . .  |  |
| 604 HZ              | -4.7 DBM  | 704 HZ   | -2.7 DBM  | . . .  |  |
| .                   |           |          |           |        |  |
| .                   |           |          |           |        |  |
| .                   |           |          |           |        |  |
| 3904 HZ             | -12.5 DBM |          |           |        |  |

Figure 14-1  
Frequency Sweep Printout

---

**SECTION 14****14.5 MEASUREMENTS****14.5.1 CHANNEL Category Measurements**

Table 14-2 describes the CHANNEL category results made available with the VF Option. The results are only available when the T-BERD 224 CHANNEL FORMAT switch is set to VF or VF THRU.

**Table 14-2**  
**VF Option CHANNEL Category Measurements**

| <b>Results Name</b> | <b>Description</b>                                                                                                                                                                                                                                                                                |
|---------------------|---------------------------------------------------------------------------------------------------------------------------------------------------------------------------------------------------------------------------------------------------------------------------------------------------|
| n81 VF FREQ         | Voice Frequency. The frequency (Hz) of a VF tone within a selected dropped channel when the <b>DROP</b> switch is set to LINE 1 or LINE 2.                                                                                                                                                        |
| n82 VF LVL          | VF Level. The level (dBm) of a VF tone within a selected DS0 channel referenced to a digital milliwatt.                                                                                                                                                                                           |
| n84 3KFLAT          | 3 kHz Flat Noise. A measure of the noise (dBm) weighted with a 3 kHz flat filter. Used when qualifying data-grade circuits.                                                                                                                                                                       |
| n85 3K NCH          | 3 kHz Notch Noise. A measure of the noise (dBm) against a weighted 3 kHz flat filter with a transmitted 1004 Hz tone that is filtered out prior to the measurement for analog data-grade analysis. This measurement includes quantization noise caused by analog/digital conversion in the CODEC. |
| n86 C-MSG           | C-Message Noise. A measure of the noise (in dBmC) weighted with a C-message distribution for voice-grade analysis. This measurement determines the idle channel noise on a circuit.                                                                                                               |
| n87 C-NCH           | C-Message Notch Noise. A measure of the noise (in dBmC) against a weighted C-message filter with a transmitted 1004 Hz tone that is filtered out prior to the                                                                                                                                     |

**Table 14-2**  
**VF Option CHANNEL Category Measurements (Continued)**

| Results Name | Description                                                                                                                                                                                                                                    |
|--------------|------------------------------------------------------------------------------------------------------------------------------------------------------------------------------------------------------------------------------------------------|
| n88 S/N      | measurement for voice-grade analysis. This measurement includes quantization noise caused by Analog/Digital conversion in the CODEC.                                                                                                           |
| n89 DC-OFF   | Signal-to-Noise Ratio. The ratio (in dB) of received signal level to noise level. The noise level is weighted with a C-message filter with a transmitted 1004 Hz tone that is filtered out prior to the measurement.                           |
| n90 P/AR     | DC-Offset. The average DC voltage level (in mV) of the received analog signal with respect to time. VF signals should have DC offsets of approximately zero millivolts (0 mV).                                                                 |
| n91 PAR LV   | Peak to Average Ratio. The ratio (in P/AR units) of transmitted peak signal level of 16 non-harmonically related frequencies to the average received level of the signal. This measurement is only available when PAR is selected as the test. |
| n92 ERL      | Peak to Average Ratio Level. The RMS level (in dBm) of the received signal. This measurement is only available when P/AR is selected as the test.                                                                                              |
| n93 SRL-HI   | Echo Return Loss. The ratio (in dB) of the power transmitted by the T-BERD 224 to the power reflected by the terminated circuit ( $ERL = 10 \log (TX \text{ power}/RX \text{ power})$ ).                                                       |
| n94 SRL-LO   | Singing Return Loss - High. The ratio (in dB) of the noise power transmitted for a shaped high frequency band to the power reflected by the terminated circuit.                                                                                |
|              | Singing Return Loss - Low. The ratio (in dB) of the noise power transmitted for a shaped low frequency band to the power reflected by the terminated circuit.                                                                                  |

## **14.6 OUT-OF-SERVICE TESTING**

This section describes the out-of-service tests that the T-BERD 224 VF Option provides for determining the operating conditions of voice-grade and data-grade analog circuits carried on T1 systems. The capabilities added by the VF Option enable the user to perform voice-grade noise analysis, three-tone slope, and return loss measurements. In addition, the VF Option allows the user to perform data-grade tests, including an automated frequency sweep that generates a frequency vs. level chart, data-grade noise analysis, and a peak-to-average ratio (P/AR) measurement of signal degradation.

### **14.6.1 Voice-Grade Noise Testing**

Noise is measured as noise energy, a signal level expressed in dBm or dBmC which is referenced to -90 dBm (i.e., 0 dBm = -90 dBm). Noise can be measured with or without a holding tone (e.g., 1004 Hz). Noise measured without a holding tone measures background or idle channel noise. Noise measured with a holding tone measures the operating noise created by channel equipment, including quantizing noise, harmonic distortion, and jitter. Noise is measured with filters which are sensitive to a specific application. When using a 3 kHz filter, the units are dBm. When using a C-Message filter, the units are dBmC.

Tables 14-3 and 14-4 present the test procedures for obtaining the C-Message and C-Notch noise measurements, respectively. Since these procedures will normally be performed as part of the same test, only Table 14-3 contains the set-up part of the procedure. In both procedures, the T-BERD 224 is performing an end-to-end test in conjunction with a VF test set located at the end of a VF local loop (see Figure 14-2). The far-end test set should perform its respective test set-up to match the procedure on the T-BERD 224.

**Table 14-3**  
**Collecting C-Message Noise Results**

| Step | Controls/Indicators/<br>Connections | Activity                                                                                                                                                                                                                                                                                                                                                                                                                                      |
|------|-------------------------------------|-----------------------------------------------------------------------------------------------------------------------------------------------------------------------------------------------------------------------------------------------------------------------------------------------------------------------------------------------------------------------------------------------------------------------------------------------|
| 1.   | T1 Circuit Connections              | <p>Perform the procedure in Section 4.2.2, Drop and Insert Testing, to connect the T-BERD 224 to the T1 circuit for testing with the following parameters:</p> <p>(a) <b>MODE</b> switch is set to desired T1 format or AUTO.</p> <p>(b) <b>CHANNEL FORMAT</b> switch is set to either VF or VF THRU.</p> <p>(c) <b>SCI</b> switch is set to QUIET.</p> <p><b>NOTE:</b> Ensure that the far-end test set is providing a quiet termination</p> |
| 2.   | <b>TEST</b> switch                  | Set to CONT.                                                                                                                                                                                                                                                                                                                                                                                                                                  |
| 3.   | <b>DROP</b> switch                  | Select LINE 1 or LINE 2, depending on which line contains the channel to be analyzed (LINE 1 in Figure 14-2).                                                                                                                                                                                                                                                                                                                                 |
| 4.   | <b>INSERT</b> switch                | Select the line opposite that of the <b>DROP</b> switch selection.                                                                                                                                                                                                                                                                                                                                                                            |
| 5.   | <b>RESULTS I Category</b> switch    | Select the CHANNEL Category.                                                                                                                                                                                                                                                                                                                                                                                                                  |
| 6.   | <b>RESULTS I Results</b> switch     | Select n81 VFFREQ, where n equals the line number selected by the <b>DROP</b> switch.                                                                                                                                                                                                                                                                                                                                                         |
| 7.   | <b>RESULTS II Category</b> switch   | Select the SUMMARY Category.                                                                                                                                                                                                                                                                                                                                                                                                                  |



**Table 14-3**  
**Collecting C-Message Noise Results (Continued)**

| Step | Controls/Indicators/Connections | Activity                                                                                                |
|------|---------------------------------|---------------------------------------------------------------------------------------------------------|
| 8.   | RESULTS Verification            | Verify the reception of a 0 Hz tone (Quiet) from the far-end test set.                                  |
| 9.   | <b>RESULTS I Results</b> switch | Select n86 C-MSG, where n equals the line number selected by the <b>DROP</b> switch. Record the result. |
| 10.  | C-Notch Noise and S/N Ratio     | Proceed to Table 14-2 to obtain C-Notch Noise and S/N Ratio Results.                                    |

If the SUMMARY category records BPV, FRAME, or CRC errors, the T1 span line is experiencing errors that could be corrupting the VF channel measurements.

**Table 14-4**  
**Collecting C-Notch Noise and S/N Ratio Results**

| Step | Controls/Indicators/Connections | Activity                                                                                                                                                                     |
|------|---------------------------------|------------------------------------------------------------------------------------------------------------------------------------------------------------------------------|
| 1.   | <b>SCI</b> switch               | Select LEVEL to set the T-BERD 224 transmit level.                                                                                                                           |
| 2.   | <b>SCII</b> switch              | Set the transmit level (typically -16 dBm).                                                                                                                                  |
| 3.   | <b>SCI</b> switch               | Select 3-TONE SLOPE.                                                                                                                                                         |
| 4.   | <b>SCII</b> switch              | Select 1004 Hz.                                                                                                                                                              |
| 5.   | <b>INSERT</b> switch            | Select LINE 1 or LINE 2, depending on the remote test set's location, to transmit the 1004 Hz tone toward the far-end test set or loopback location (LINE 2 in Figure 14-2). |

**Table 14-4**  
**Collecting C-Notch Noise and S/N Ratio Results (Continued)**

| Step | Controls/Indicators/<br>Connections  | Activity                                                                                                                                                 |
|------|--------------------------------------|----------------------------------------------------------------------------------------------------------------------------------------------------------|
| 6.   | <b>DROP</b> switch                   | Select the line opposite that of the <b>INSERT</b> switch selection. This channel will be analyzed by the T-BERD 224.                                    |
| 7.   | Speaker and<br><b>VOLUME</b> switch  | Verify that far end is sending 1004 Hz by listening to the speaker.                                                                                      |
| 8.   | <b>RESULTS I Results</b><br>switch   | Select n81 VF FREQ, where n equals the line number selected by the <b>DROP</b> switch. Verify the reception of a 1004 Hz tone from the far-end test set. |
| 9.   | <b>RESULTS II Category</b><br>switch | Select the CHANNEL Category.                                                                                                                             |
| 10.  | <b>RESULTS II Results</b><br>switch  | Select n82 VF LVL, where n equals the line number selected by the <b>DROP</b> switch. Record the result.                                                 |
| 11.  | <b>RESULTS I Results</b><br>switch   | Select n86 C-NOTCH, where n equals the line number selected by the <b>DROP</b> switch. Record the result.                                                |
| 12.  | <b>RESULTS I Results</b><br>switch   | Select n88 S/N, where n equals the line number selected by the <b>DROP</b> switch. Record the result.                                                    |

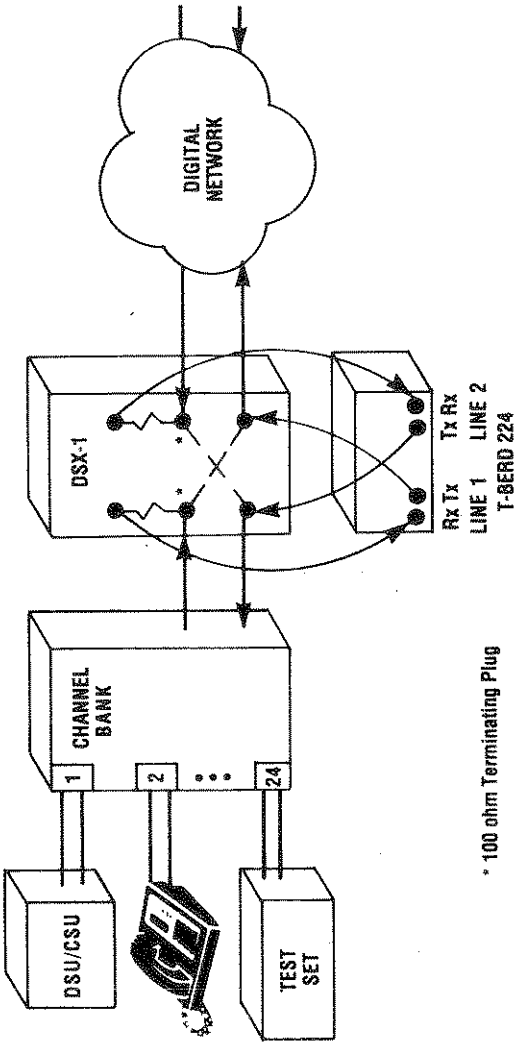

Figure 14-2  
Voice-Grade Noise Testing Set-up

Refer to the following items to interpret the test results:

- If the receive frequency varies from 1004 Hz  $\pm$  2 Hz, the C-notch measurement will be slightly higher than expected. The far end should be sending a 1004 Hz.
- If the C-message noise result exceeds defined thresholds, the circuit may be affected by crosstalk, 60 Hz noise induction, or a variety of other impairments on the local loop.
- If the C-notch noise exceeds thresholds while C-message noise is within its thresholds, a problem may exist in a VF repeater, CODEC, or other active device in the circuit.

### 14.6.2 Three Tone Slope Testing

Three tone slope testing measures VF Level (n82 VFLVL) for 404 Hz, 1004 Hz, and 2804 Hz tones to estimate the circuit's frequency response or attenuation distortion. The VF Level result for 1004 Hz is compared to the VF Level results at 404 Hz and 2804 Hz. This comparison is performed by the user to estimate the VF channel's frequency response across the VF spectrum based on the three test tone results.

Table 14-5 presents the test procedure for obtaining the three tone slope results. The T-BERD 224 loops the far end and performs the test from the DSX-1 in the central office (see Figure 14-3).

**NOTE:** This procedure involves looping a far-end modem or loopback device with a 2713 Hz tone. For end-to-end testing, a second test set is needed.

The difference between the level at 1004 Hz and the level at 404 and 2804 Hz should be  $\pm$ 10 dB maximum.

**Table 14-5**  
**Collecting Three Tone Slope Results**

| Step | Controls/Indicators/<br>Connections                        | Activity                                                                                                                                                                                                                                                                                                  |
|------|------------------------------------------------------------|-----------------------------------------------------------------------------------------------------------------------------------------------------------------------------------------------------------------------------------------------------------------------------------------------------------|
| 1.   | T1 Circuit Connections                                     | <p>Perform the procedure in Section 4.2.2, Drop and Insert Testing, to connect the T-BERD 224 to the T1 circuit for testing with the following parameters:</p> <p>(a) <b>MODE</b> switch is set to desired T1 format or AUTO.</p> <p>(b) <b>CHANNEL FORMAT</b> switch is set to either VF or VF THRU.</p> |
| 2.   | <b>TEST</b> switch                                         | Set to CONT.                                                                                                                                                                                                                                                                                              |
| 3.   | <b>INSERT</b> switch                                       | Select either LINE 1 or LINE 2 depending on the desired loopback location (LINE 1 in Figure 14-3).                                                                                                                                                                                                        |
| 4.   | <b>DROP</b> switch                                         | Select the line opposite the <b>INSERT</b> switch selection.                                                                                                                                                                                                                                              |
| 5.   | <b>SCI</b> switch                                          | Select 2713 to activate the loopback tone.                                                                                                                                                                                                                                                                |
| 6.   | <b>SCII</b> switch                                         | Select ON. Send the tone for approximately 5 seconds to loop the far-end device, then select OFF.                                                                                                                                                                                                         |
| 7.   | <b>SCI</b> switch                                          | Select LEVEL.                                                                                                                                                                                                                                                                                             |
| 8.   | <b>SCII</b> switch                                         | Set the transmit level (typically -16 dBm).                                                                                                                                                                                                                                                               |
| 9.   | <b>SCI</b> switch                                          | Select 3-TONE SLOPE.                                                                                                                                                                                                                                                                                      |
| 10.  | <b>SCII</b> switch                                         | Select 1004 Hz.                                                                                                                                                                                                                                                                                           |
| 11.  | <b>RESULTS I</b> and <b>II</b><br><b>Category</b> switches | Select the CHANNEL Category.                                                                                                                                                                                                                                                                              |
| 12.  | <b>RESULTS I Results</b><br>switch                         | Select n81 VF FREQ, where n equals the line number selected by the <b>DROP</b> switch. Verify the reception of a 1004 Hz tone.                                                                                                                                                                            |

**Table 14-5**  
**Collecting Three Tone Slope Results (Continued)**

| Step | Controls/Indicators/<br>Connections | Activity                                                                                                                                 |
|------|-------------------------------------|------------------------------------------------------------------------------------------------------------------------------------------|
| 13.  | <b>RESULTS II Results</b><br>switch | Select n82 VF LVL, where n equals the line number selected by the <b>DROP</b> switch. Record the result.                                 |
| 14.  | <b>SCII</b> switch                  | Select 404 Hz.                                                                                                                           |
| 15.  | <b>RESULTS I</b> Verification       | Verify reception of 404 Hz tone by observing the <b>RESULTS I</b> display (n81 VF FREQ).                                                 |
| 16.  | <b>RESULTS II</b> Recording         | Record the result (n82 VF LVL) now displayed in the <b>RESULTS II</b> window and compare it with the measured level of the 1004 Hz tone. |
| 17.  | <b>SCII</b> switch                  | Select 2804 Hz.                                                                                                                          |
| 18.  | <b>RESULTS I</b> Verification       | Verify reception of 2804 Hz tone by observing the <b>RESULTS I</b> window (n81 VF FREQ).                                                 |
| 19.  | <b>RESULTS II</b> Recording         | Record the result (n82 VF LVL) now displayed in the <b>RESULTS II</b> window and compare it with the measured level of the 1004 Hz tone. |

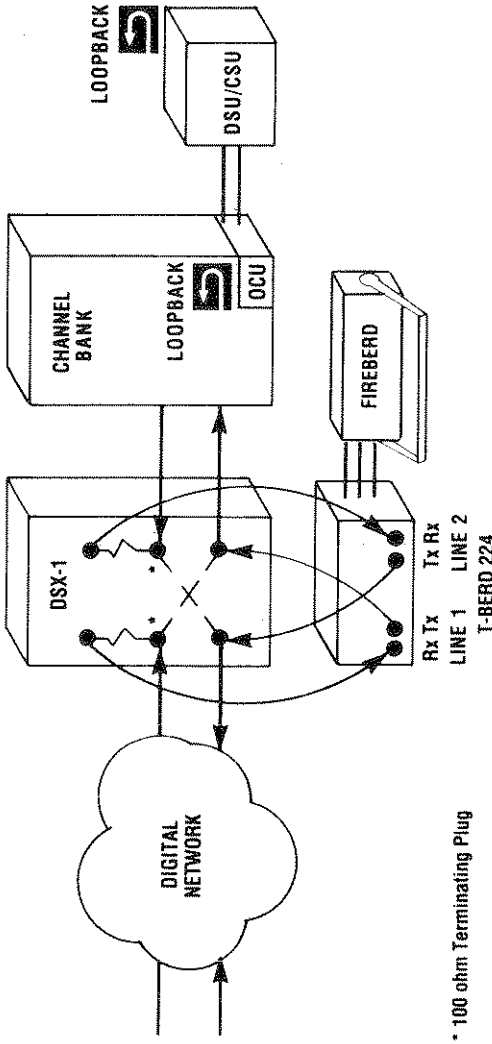

Figure 14-3  
Three Tone Slope Testing Set-up

### 14.6.3 Voice-Grade Return Loss Testing

Return loss testing includes Echo Return Loss (n92 ERL), Singing Return Loss - High (n93 SRL-HI), and Singing Return Loss - Low (n94 SRL-LO) results. Return loss measurements reflect the circuit's impedance and gain matching at the various interfaces (i.e., 2-wire/4-wire interfaces).

Table 14-6 presents the test procedure for obtaining the return loss results. The T-BERD 224 loops the far end and performs the test from the DSX-1 using the same setup as in Figure 14-3.

**Table 14-6**  
**Collecting Return Loss Results**

| Step | Controls/Indicators/<br>Connections | Activity                                                                                                                                                                                                                                                                                           |
|------|-------------------------------------|----------------------------------------------------------------------------------------------------------------------------------------------------------------------------------------------------------------------------------------------------------------------------------------------------|
| 1.   | T1 Circuit Connections              | Perform the procedure in Section 4.2.2, Drop and Insert Testing, to connect the T-BERD 224 to the T1 circuit for testing with the following parameters:<br><br>(a) <b>MODE</b> switch is set to desired T1 format or AUTO.<br><br>(b) <b>CHANNEL FORMAT</b> switch is set to either VF or VF THRU. |
| 2.   | <b>TEST</b> switch                  | Set to CONT.                                                                                                                                                                                                                                                                                       |
| 3.   | <b>INSERT</b> switch                | Select LINE 1 or LINE 2 depending on the desired loopback location (LINE 1 in Figure 14-3).                                                                                                                                                                                                        |
| 4.   | <b>DROP</b> switch                  | Select the line opposite the <b>INSERT</b> switch selection.                                                                                                                                                                                                                                       |
| 5.   | <b>SCI</b> switch                   | Select ERL.                                                                                                                                                                                                                                                                                        |



**Table 14-6**  
**Collecting Return Loss Results (Continued)**

| Step | Controls/Indicators/<br>Connections | Activity                                                                                                                                                                                                                                                             |
|------|-------------------------------------|----------------------------------------------------------------------------------------------------------------------------------------------------------------------------------------------------------------------------------------------------------------------|
| 6.   | <b>AUX</b> switch                   | <p>(a) If VFBURST is required to disable the echo canceller(s) on the span, select Auxiliary Functions (AUX switch LED is illuminated). AUX 22 VFBURST is displayed automatically.</p> <p>(b) If VFBURST is not required, skip this step and Steps 7 through 10.</p> |
| 7.   | <b>SCII</b> switch                  | Set BURST ON if required to disable the echo canceller(s).                                                                                                                                                                                                           |
| 8.   | <b>RESULTS I</b> Category switch    | Set the VFBURST FREQ (default 2125 Hz).                                                                                                                                                                                                                              |
| 9.   | <b>RESULTS II</b> Results switch    | Set VFBURST LEVEL (default -10.0 dBm).                                                                                                                                                                                                                               |
| 10.  | <b>AUX</b> switch                   | Press to exit the Auxiliary Functions.                                                                                                                                                                                                                               |
| 11.  | <b>RESULTS I</b> Category switch    | Select the CHANNEL Category.                                                                                                                                                                                                                                         |
| 12.  | <b>RESULTS I</b> Results switch     | Select n92 ERL, where n equals the line number selected by the <b>DROP</b> switch. Record the result.                                                                                                                                                                |
| 13.  | <b>SCI</b> switch                   | Select SRL-HI.                                                                                                                                                                                                                                                       |
| 14.  | <b>RESULTS I</b> Results switch     | Select n93 SRL-HI, where n equals the line number selected by the <b>DROP</b> switch. Record the result.                                                                                                                                                             |
| 15.  | <b>SCI</b> switch                   | Select SRL-LO.                                                                                                                                                                                                                                                       |
| 16.  | <b>RESULTS I</b> Results switch     | Select n94 SRL-LO, where n equals the line number selected by the <b>DROP</b> switch. Record the result.                                                                                                                                                             |

#### 14.6.4 Data-Grade Noise Testing

Noise can be very disruptive to data transmissions which are more sensitive to line impairments. Since C-Message noise filters are designed to analyze the noise most apparent to the human ear, C-Message and C-Notch Noise are not the best measurements for VF data-grade circuits. Instead, filters which are more relevant to data transmissions and provide linear response across the data-grade frequency band should be used. To measure low frequency noise due primarily to AC power line interference, the VF Option provides 3 kHz Flat Noise in a range from 20 to 70 dBm. To determine the noise present when a signal is being transmitted, a 1004 Hz tone is filtered out prior to measurement, and the result is a 3 kHz Notch noise measurement from 20 to 70 dBm.

The procedures for performing 3 kHz flat noise and 3 kHz notch noise testing are exactly the same as the procedures for performing C-message and C-notch noise tests (Refer to Section 14.6.1, Voice Grade Noise Testing). Replace n86 C-MSG with n84 3K FLAT and replace n87 C-NCH with n85 3K NCH for the **RESULTS I** and **RESULTS II Results** switch positions.

#### 14.6.5 Data-Grade Frequency Sweep Versus Level Analysis

As a measure of frequency response, the Frequency Sweep function provides a series of tones at user-specified frequencies and levels. The VF Option averages the level of each received tone for a user-determined interval. These results provide a large number of data points for the user to analyze the frequency response of the data-grade circuit. Frequency sweep analysis provides more detail of the attenuation distortion than sloped tone analysis since the entire frequency bandwidth may be analyzed at multiple intervals, instead of only at three distinct frequencies. This detailed analysis is important for VF data-grade circuits, since data requires consistent quality over the entire frequency range. The frequency range of 2450 Hz to 2750 Hz should not be tested to avoid inadvertent loopbacks or billings caused by 2713 Hz and 2600 Hz tones respectively (i.e., the SKIP-HI and SKIP-LO frequency band).

Table 14-7 presents the test procedure for collecting Frequency Sweep results.

**Table 14-7**  
**Collecting Frequency Sweep Results**

| Step | Controls/Indicators/<br>Connections | Activity                                                                                                                                                                                                                                                                                                                                                                                        |
|------|-------------------------------------|-------------------------------------------------------------------------------------------------------------------------------------------------------------------------------------------------------------------------------------------------------------------------------------------------------------------------------------------------------------------------------------------------|
| 1.   | T1 Circuit Connections              | Perform the procedure in Section 4.2.2, Drop and Insert Testing, to connect the T-BERD 224 to the T1 circuit for testing with the following parameters: <ul style="list-style-type: none"> <li>(a) <b>MODE</b> switch is set to desired T1 format or AUTO.</li> <li>(b) <b>CHANNEL FORMAT</b> switch is set to either VF or VF THRU.</li> <li>(c) <b>SCI</b> switch is set to SWEEP.</li> </ul> |
| 2.   | <b>TEST</b> switch                  | Set to CONT.                                                                                                                                                                                                                                                                                                                                                                                    |
| 3.   | <b>AUX</b> switch                   | Select Auxiliary Functions (AUX switch LED is illuminated). AUX 21 SWEEP is displayed automatically                                                                                                                                                                                                                                                                                             |
| 4.   | <b>SCI</b> switch                   | Select END-POINT.                                                                                                                                                                                                                                                                                                                                                                               |
| 5.   | <b>RESULTS I Category</b> switch    | Set the START frequency (default 104 Hz).                                                                                                                                                                                                                                                                                                                                                       |
| 6.   | <b>RESULTS II Results</b> switch    | Set the STOP frequency (default 3704 Hz).                                                                                                                                                                                                                                                                                                                                                       |
| 7.   | <b>SCI</b> switch                   | Select STEP.                                                                                                                                                                                                                                                                                                                                                                                    |
| 8.   | <b>RESULTS I Category</b> switch    | Set the STEP-SIZE frequency (default 100 Hz).                                                                                                                                                                                                                                                                                                                                                   |
| 9.   | <b>RESULTS II Results</b> switch    | Set the STEP-INTVL time (default 2.0 SEC).                                                                                                                                                                                                                                                                                                                                                      |
| 10.  | <b>SCI</b> switch                   | Select SKIP.                                                                                                                                                                                                                                                                                                                                                                                    |
| 11.  | <b>RESULTS I Category</b> switch    | Set the SKIP-HI frequency (default 2750 Hz).                                                                                                                                                                                                                                                                                                                                                    |
| 12.  | <b>RESULTS II Results</b> switch    | Set the SKIP-LO frequency (default 2450 Hz).                                                                                                                                                                                                                                                                                                                                                    |
| 13.  | <b>MODE</b> switch                  | Select AUX 23 PRT OPT.                                                                                                                                                                                                                                                                                                                                                                          |

**Table 14-7**  
**Collecting Frequency Sweep Results (Continued)**

| Step | Controls/Indicators/<br>Connections                        | Activity                                                                                                                                                                                                                                                                                                               |
|------|------------------------------------------------------------|------------------------------------------------------------------------------------------------------------------------------------------------------------------------------------------------------------------------------------------------------------------------------------------------------------------------|
|      |                                                            | <p><b>NOTE:</b> The T-BERD 224 automatically performs a validation check of the entered values. If the parameters are inconsistent, an error message will flash for 2 seconds, the frequency sweep set-up operation is aborted, and the original settings remain. The user will need to repeat steps 4 through 13.</p> |
| 14.  | <b>SCII</b> switch                                         | Select ON to generate a Frequency versus Level printout, if desired. Otherwise, skip this step and Step 15.                                                                                                                                                                                                            |
| 15.  | RESULTS Verification                                       | Verify there is a printer connected to the T-BERD 224 and that it is turned ON and is ON-LINE.                                                                                                                                                                                                                         |
| 16.  | <b>AUX</b> switch                                          | Press to exit the Auxiliary Functions.                                                                                                                                                                                                                                                                                 |
| 17.  | <b>INSERT</b> switch                                       | Select either LINE 1 or LINE 2, depending on the remote loopback location, to transmit the frequency sweep toward the loopback location. Once the <b>INSERT</b> switch is set to LINE 1 or LINE 2, the T-BERD 224 will begin transmitting the frequency sweep test signal 0.5 seconds after the selection is made.     |
| 18.  | <b>DROP</b> switch                                         | Select the line opposite that of the <b>INSERT</b> switch selection.                                                                                                                                                                                                                                                   |
| 19.  | <b>SCII</b> switch                                         | Press to set the transmit level (typically -13.0 dBm).                                                                                                                                                                                                                                                                 |
| 20.  | <b>RESULTS I</b> and <b>II</b><br><b>Category</b> switches | Select the CHANNEL category.                                                                                                                                                                                                                                                                                           |
| 21.  | <b>RESULTS I Results</b><br>switch                         | Select n81 VF FREQ, where n equals the line number selected by the <b>DROP</b> switch.                                                                                                                                                                                                                                 |
| 22.  | <b>RESULTS II Results</b><br>switch                        | Select n82 VF LVL, where n equals the line number selected by the <b>DROP</b> switch.                                                                                                                                                                                                                                  |

**14.6.6 Data-Grade Peak-to-Average Ratio Analysis**

The Peak-to-Average Ratio (P/AR) is a measure of signal dispersion or spreading due to transmission imperfections such as envelope delay distortion, noise, bandwidth reduction, and nonlinearities such as clipping and compression. Peak-to-Average Ratio is expressed in units and is measured by comparing a received P/AR signal to a known P/AR transmitted waveform. The transmitted P/AR waveform is a complex signal consisting of 16 non-harmonically related tones with a known envelope shape that approximates a data signal. P/AR analysis cannot isolate the impairment type or cause, but it is a figure of merit used to quickly appraise a circuit's data transmission quality. A perfect channel would provide a P/AR reading of 100 units.

**Table 14-8  
Collecting P/AR Results**

| Step | Controls/Indicators/Connections | Activity                                                                                                                                                                                                                                                                                                                                                                                      |
|------|---------------------------------|-----------------------------------------------------------------------------------------------------------------------------------------------------------------------------------------------------------------------------------------------------------------------------------------------------------------------------------------------------------------------------------------------|
| 1.   | T1 Circuit Connections          | Perform the procedure in Section 4.2.2, Drop and Insert Testing, to connect the T-BERD 224 to the T1 circuit for testing with the following parameters: <ul style="list-style-type: none"> <li>(a) <b>MODE</b> switch is set to desired T1 format or AUTO.</li> <li>(b) <b>CHANNEL FORMAT</b> switch is set to either VF or VF THRU.</li> <li>(c) <b>SCI</b> switch is set to PAR.</li> </ul> |
| 2.   | <b>TEST</b> switch              | Set to CONT.                                                                                                                                                                                                                                                                                                                                                                                  |
| 3.   | <b>SCII</b> switch              | Set the level for the transmitted P/AR spectrum (typically -13.0 dBm).                                                                                                                                                                                                                                                                                                                        |
| 4.   | <b>INSERT</b> switch            | Select either LINE 1 or LINE 2, depending on the remote loopback location, to transmit the P/AR spectrum toward the loopback location.                                                                                                                                                                                                                                                        |

**Table 14-8**  
**Collecting P/AR Results (Continued)**

| Step | Controls/Indicators/<br>Connections | Activity                                                                            |
|------|-------------------------------------|-------------------------------------------------------------------------------------|
| 5.   | <b>DROP</b> switch                  | Select the line opposite that of the <b>INSERT</b> switch selection.                |
| 6.   | <b>RESULTS I Category</b> switch    | Select the CHANNEL category.                                                        |
| 7.   | <b>RESULTS I Results</b> switch     | Select n90 P/AR, where n equals the line number selected by the <b>DROP</b> switch. |

## 14.7 ERROR MESSAGES

Most error messages contain the prefix **ERROR** and are terminated by a CR, LF, or CRLF sequence, as selected by AUX 08 RS 232 (see Section 2.5, Auxiliary Functions). For a detailed discussion of error messages see Section 6.4, Error Messages. The following is a list of possible VF Option error messages and a brief explanation of what may have caused the error.

**ERROR:** *Floating point number can have only one decimal digit.*

A VF Level entry was made with 2 digits after the decimal point when only one digit is allowed.

**ERROR:** *Skip low is greater than skip high.*

The SKIP-LO frequency value entered is larger than the SKIP-HI frequency value. Refer to Section 14.4, Auxiliary Functions, for the valid settings.

**ERROR:** *Skip range exceeds sweep range.*

The frequency range between the SKIP-LO and SKIP-HI frequencies is larger than the SWEEP frequency range between the START and STOP frequencies. Refer to Section 14.4, Auxiliary Functions, for the valid settings.

**ERROR:** *Step size exceeds sweep range.*

The STEP-SIZE frequency entered is larger than the SWEEP frequency range between the START and STOP frequencies. Refer to Section 14.4, Auxiliary Functions, for the valid settings.

## 14.8 REMOTE CONTROL COMMANDS

Table 14-9 list the available remote control commands that enable the VF Option to be controlled from a remote device. The remote control commands are described in the following sections.

**Table 14-9**  
**VF Option Remote Control Commands**

| Command         | Name                                           |
|-----------------|------------------------------------------------|
| BUR             | Set VF burst ON or OFF                         |
| BUR FRE         | Set VF burst frequency (in Hz)                 |
| BUR LEV         | Set VF burst level (in dBm)                    |
| FRE SWE SKI HIG | Set Frequency Sweep SKIP-HI Frequency          |
| FRE SWE SKI LOW | Set Frequency Sweep SKIP-LO Frequency          |
| FRE SWE STA FRE | Set Frequency Sweep START Frequency            |
| FRE SWE STE INT | Set Frequency Sweep STEP-INTVL Time            |
| FRE SWE STE SIZ | Set Frequency Sweep STEP-SIZE Frequency        |
| FRE SWE STO FRE | Set Frequency Sweep STOP Frequency             |
| HELLO           | Display the T-BERD 224 Software Revision Level |
| HELP            |                                                |
| PRI SWE         | Set Frequency printout ON or OFF               |
| PRI SWE PAR     | List the Frequency Sweep parameters            |
| SOU 1           | Set Source Configuration I                     |
| SOU 2           | Set Source Configuration II                    |

BUR

BUR

Set VF Burst ON or OFF

**BUR?** :Displays the current status of the VF burst function

**BUR [ON|OFF]** :Enable or disable the VF burst

The valid parameters for VF burst frequency are ON or OFF. This command is identical to pressing the **SCII** switch while in AUX 22 VFBURST.

EXAMPLE:

>**BUR?** :Displays the current status of VF burst

BURst FREq: 2125 Hz

BURst LEVel: -10.0 dBm

BURst OFF

>**BUR ON** :Sets the VF burst function ON

>



---

---

## SECTION 14

**BUR FRE**

**BUR FRE**

### Set VF Burst Frequency

**BUR FRE?** :Displays the current setting of the VF burst frequency

**BUR FRE (parameter)** :Sets the VF burst frequency to the (parameter) value

The valid parameters for VF burst frequency are the frequencies from 20 Hz to 3904 Hz. This command is identical to pressing the **RESULTS | Category** switch while in **AUX 22 VFBURST**.

#### EXAMPLE:

**>BUR FRE?** :Displays the current setting of the VF burst frequency

BURst FREq: 2125 Hz

**>BUR FRE 2000** :Sets the VF burst frequency to 2000 Hz

**>**

**BUR LEV****BUR LEV**

## Set VF Burst Level

**BUR LEV?** :Displays the current setting of the VF burst level

**BUR LEV (parameter)** :Sets the VF burst LEVEL to the (parameter) value

The valid parameters for VF burst level are the settings from -40.0 dBm to +3.0 dBm. This command is identical to pressing the **RESULTS II Results** switch while in AUX 22 VFBURST.

## EXAMPLE:

**>BUR LEV?** :Displays the current setting of the VF burst level

BURst LEVel: -10.0 dBm

**>BUR LEV -13.0** :Sets the VF burst frequency to -13.0 dBm

**>**

---

---

**SECTION 14****FRE SWE SKI HIG****FRE SWE SKI HIG**

Set VF Frequency Sweep SKIP-HI Frequency

**FRE SWE SKI HIG?** :Displays the current setting of the VF Frequency Sweep SKIP-HI frequency**FRE SWE SKI HIG (parameter)** :Sets the VF Frequency Sweep SKIP-HI frequency to the **(parameter)** value

The valid parameters for VF Frequency Sweep SKIP-HI are the frequencies from 20 Hz to 3904 Hz. This command is identical to pressing the **RESULTS** | **Category** switch while in AUX 21 SWEEP, SKIP parameter.

EXAMPLE:

**>FRE SWE SKI HIG?** :Displays the current setting of the VF Frequency Sweep SKIP-HI frequency

SWEep SKIp HIGH: 2750 Hz

**>FRE SWE SKI HIG 2000** :Sets the VF Frequency Sweep SKIP-HI frequency to 2000 Hz**>**

FRE SWE SKI LOW

FRE SWE SKI LOW

## Set VF Frequency Sweep SKIP-LO Frequency

**FRE SWE SKI LOW?** :Displays the current setting of the VF Frequency Sweep SKIP-LO frequency

**FRE SWE SKI LOW (parameter)** :Sets the VF Frequency Sweep SKIP-LO frequency to the **(parameter)** value

The valid parameters for VF Frequency Sweep SKIP-LO are the frequencies from 20 Hz to 3904 Hz. This command is identical to pressing the **RESULTS II Results** switch while in AUX 21 SWEEP, SKIP parameter.

## EXAMPLE:

**>FRE SWE SKI LOW?** :Displays the current setting of the VF Frequency Sweep SKIP-LO frequency

SWEep SKIp LOW: 2450 Hz

**>FRE SWE SKI LOW 1750** :Sets the VF Frequency Sweep SKIP-LO frequency to 1750 Hz

>

---

---

**SECTION 14****FRE SWE STA FRE****FRE SWE STA FRE**

Set VF Frequency Sweep START Frequency

**FRE SWE STA FRE?** :Displays the current setting of the VF Frequency Sweep START frequency**FRE SWE STA FRE (parameter)** :Sets the VF Frequency Sweep START frequency to the **(parameter)** value

The valid parameters for VF Frequency Sweep START are the frequencies from 20 Hz to 3904 Hz. This command is identical to pressing the **RESULTS** | **Category** switch while in AUX 21 SWEEP, END-POINT parameter.

EXAMPLE:

**>FRE SWE STA FRE?** :Displays the current setting of the VF Frequency Sweep START frequency

SWEep STArt FREq: 104 Hz

**>FRE SWE STA FRE 250** :Sets the VF Frequency Sweep START frequency to 250 Hz

&gt;

FRE SWE STE SIZ

FRE SWE STE SIZ

## Set VF Frequency Sweep STEP-SIZE Frequency

**FRE SWE STE SIZ?** :Displays the current setting of the VF Frequency Sweep STEP-SIZE frequency

**FRE SWE STE SIZ (parameter)** :Sets the VF Frequency Sweep STEP-SIZE frequency to the **(parameter)** value

The valid parameters for VF Frequency Sweep STEP-SIZE are the frequencies from 10 Hz to 1000 Hz. This command is identical to pressing the **RESULTS I Category** switch while in AUX 21 SWEEP, STEP parameter.

## EXAMPLE:

**>FRE SWE STE SIZ?** :Displays the current setting of the VF Frequency Sweep STEP-SIZE frequency

SWEp STEp SIZe: 100 Hz

**>FRE SWE STE SIZ 250** :Sets the VF Frequency Sweep STEP-SIZE frequency to 250 Hz

**>**

---

---

**SECTION 14**

**FRE SWE STE INT**

**FRE SWE STE INT**

Set VF Frequency Sweep STEP-INTVL Time

**FRE SWE STE INT?** :Displays the current setting of the VF Frequency Sweep STEP-INTVL time

**FRE SWE STE INT (parameter)** :Sets the VF Frequency Sweep STEP-INTVL time to the **(parameter)** value

The valid parameters for VF Frequency Sweep STEP-INTVL are times from 1.5 seconds to 9.9 seconds. This command is identical to pressing the **RESULTS II Results** switch while in AUX 21 SWEEP, STEP parameter.

EXAMPLE:

**>FRE SWE STE INT?** :Displays the current setting of the VF Frequency Sweep STEP-INTVL time

SWEep STEp INTvl: 2.0 SEC

**>FRE SWE STE INT 3** :Sets the VF Frequency Sweep STEP-INTVL time to 3 seconds

**>**

FRE SWE STO FRE

FRE SWE STO FRE

Set VF Frequency Sweep STOP Frequency

**FRE SWE STO FRE?** :Displays the current setting of the VF Frequency Sweep STOP frequency

**FRE SWE STO FRE (parameter)** :Sets the VF Frequency Sweep STOP frequency to the **(parameter)** value

The valid parameters for VF Frequency Sweep STOP are the frequencies from 20 Hz to 3704 Hz. This command is identical to pressing the **RESULTS II Results** switch while in AUX 21 SWEEP, END-POINT parameter.

EXAMPLE:

**>FRE SWE STO FRE?** :Displays the current setting of the VF Frequency Sweep STOP frequency

SWEep STOp FREq: 3704 Hz

**>FRE SWE STO FRE 3250** :Sets the VF Frequency Sweep STOP frequency to 3250 Hz

>



---

---

**SECTION 14**

**HELLO**

**HELLO**

Display the T-BERD 224 Software Revision Level

**HELLO?** :Displays the software revision level and option configuration

**HELLO** displays the T-BERD 224 hardware and software revision levels and any options that are included in the instrument as well as any self-test errors, such as "NOVRAM LOST".

**EXAMPLE:**

**> HELLO?** :Display the hardware and software revision level

T-BERD 224, Software Version B, (c) TTC 6/30/90

DSU-DP Option installed

IEEE-488 Option installed

VF Option installed

**>**

HELP

HELP

## On-Line Help Function

**HELP 9** :Displays help information for the VF  
Option Auxiliary function commands

Refer to Section 6.5, Remote Control Commands, for additional **HELP** command information.

> **HELP 9**

TTC On-Line Manual

Page 10

The following commands control the operation of the aux functions.

|                          |                                                   |
|--------------------------|---------------------------------------------------|
| BURst FREquency          | - Set burst frequency.                            |
| BURst LEVel              | - Set burst level.                                |
| BURst ON/OFF             | - Turn on/off burst.                              |
|                          |                                                   |
| FREq SWEEp SKIp HIGH     | - Set skip high freq for freq sweep transmission. |
| FREq SWEEp SKIp LOW      | - Set skip low freq for freq sweep transmission.  |
| FREq SWEEp STArt FREq    | - Set start freq for freq sweep transmission.     |
| FREq SWEEp STEp INTerval | - Set step interval for freq sweep transmission.  |
| FREq SWEEp STEp SIZE     | - Set step size for freq sweep transmission.      |
| FREq SWEEp STOp FREq     | - Set stop freq for freq sweep transmission.      |
|                          |                                                   |
| PRInt SWEEp ON/OFF       | - Enable/disable frequency sweep print out        |
| PRInt SWEEp PARAmeters   | - Print Sweep Parameters                          |

>

---

---

**SECTION 14**

**PRI SWE**

**PRI SWE**

Set Frequency Printout ON or OFF

**PRI SWE?** :Displays current status of the Frequency printout function

**PRI SWE (ON/OFF)** :Enable or disable the Frequency printout

The valid parameters for print sweep are ON or OFF. This command is identical to pressing the **SCII** switch while in AUX 23 PRT OPT.

EXAMPLE:

**>PRI SWE?** :Displays current status of the Frequency printout

PRInt SWEep OFF

**>PRI SWE ON** :Sets the Frequency printout ON

**>**

**PRI SWE PAR**

**PRI SWE PAR**

List the Frequency Sweep Parameters

**PRI SWE PAR?**

:Displays the current status of the Frequency Sweep parameters

This command is identical to cycling the **SCI** switch through the three parameter screens, **ENDPOINT**, **STEP**, and **SKIP** while in **AUX 21 SWEEP**.

**EXAMPLE:**

**>PRI SWE PAR?**

:Displays the current status of the Frequency Sweep parameters

SWEep STArt FREq: 100 Hz  
SWEep STOp FREq: 2500 Hz  
SWEep STEp SIZE: 100 Hz  
SWEep STEp INTvl: 2.0 SEC  
SWEep SKIp HIGH: 2750 Hz  
SWEep SKIp LOW: 2450 Hz

**>**

---

---

**SECTION 14****SOU 1****SOU 1****Set Source Configuration I**

**SOU 1?** :Displays the current source configuration I selection which is equivalent to pressing the **SOURCE CONFIGURATION I** switch

**SOU 1 (parameter)** :Sets the source configuration I (**parameter**).

The following valid parameters are available with the VF Option.

|                  |                              |
|------------------|------------------------------|
| <b>2713</b>      | 2713 Hz Tone                 |
| <b>3 TON SLO</b> | 3 Tone Slope                 |
| <b>FRE</b>       | VF Signal Frequency          |
| <b>ERL</b>       | Echo Return Loss             |
| <b>LEV</b>       | VF Signal Level              |
| <b>PAR</b>       | Peak-to-Average Ratio (P/AR) |
| <b>QUI</b>       | Quiet Termination            |
| <b>SRL HIG</b>   | Singing Return Loss - High   |
| <b>SRL LOW</b>   | Singing Return Loss - Low    |
| <b>SWE</b>       | Frequency SWEEP              |

**EXAMPLE:**

**>SOU 1?** :Displays the current source configuration I setting

SOURce 1 FREquency  
**>SOU 1 LEV** :Select the VF signal level as the new source configuration

**>**

SOU 2

SOU 2

## Set Source Configuration II

**SOU 2?** :Displays the current status for the **SCII** switch selection

**SOU 2 (parameter)** :Selects the setting for the **SCII** switch

**SOU 2** augments the **SCI** switch selection. Selects or returns the drop and insert source which is to be used when analyzing the selected channel(s).

The following valid parameters are available with the VF Option.

|                           |                                               |
|---------------------------|-----------------------------------------------|
| <b>ON/OFF</b>             | When 2713 Hz is the SCI switch setting        |
| <b>404/1004/2804 Hz</b>   | When 3-TONE SLOPE is the SCI switch setting   |
| <b>20 to 3904 Hz</b>      | When FREQ is the SCI switch setting           |
| <b>-40.0 to +3.0 dBm</b>  | When LEVEL or SWEEP is the SCI switch setting |
| <b>-40.0 to -10.0 dBm</b> | When PAR is the SCI switch setting            |

## EXAMPLE:

```

>SOU 2? :Displays the current SCII switch setting
 SOURCE 2 404 Hz
>SOU 2 2804 Hz :Select the 2804 Hz setting as the next
 frequency for a 3-Tone Slope test
>

```

---

---

## SECTION 14

### 14.9 SPECIFICATIONS

The following specifications only relate to features and capabilities of the VF Option.

#### 14.9.1 Front Panel Switches

- Channel Formats: VF, VF THRU.
- Source Configuration I: 2713 Hz, 3 TONE SLOPE, ERL, FREQ, LEVEL, QUIET, PAR, SRL-HI, SRL-LO, SWEEP.
- Source Configuration II: FREQ (20 to 3904 Hz), LEVEL (-40.0 to +3.0 dBm), PAR Level (-40.0 to -10.0 dBm), 3 TONE SLOPE (404 Hz, 1004 Hz, 2804 Hz), 2713 Hz (ON,OFF).
- Results: CHANNEL — C-message noise, C-Notch noise, 3 kHz Flat noise, 3 kHz Notch noise, Signal-to-Noise Ratio (S/N), Echo Return Loss, Singing Return Loss - High, Singing Return Loss - Low, Peak-to-Average Ratio (P/AR), P/AR Level, DC offset, VF Level, VF Frequency Versus Level Sweep.
- Auxiliary Functions: VF burst, VF Sweep, Print Option.

#### 14.9.2 Measurements

All measurements/accuracies meet or exceed IEEE 743-1984 specification, where applicable.

#### VF Frequency

- Range: 20 Hz to 3904 Hz.
- Accuracy:  $\pm 1$  Hz (@ -10.0 dBm).
- Resolution: 1 Hz.

**VF Level**

- Range: +3.0 dBm to -70.0 dBm.
- Accuracy:  $\pm 0.05$  dBm between +3.0 dBm and -50.0 dBm.  
 $\pm 0.3$  dBm between -50.0 dBm and -70.0 dBm.

**Signal-to-Noise Ratio**

- Range (minimum): 0 dB to 45 dB.
- Accuracy:  $\pm 0.5$  dB.
- Resolution: 1 dB.

**C-Message Noise**

- Range (minimum): 10 dBmC to 93 dBmC.
- Accuracy:  $\pm 1$  dBmC.

**C-Notch Noise**

- Range (minimum): 20 dBmC to 93 dBmC.
- Accuracy:  $\pm 1$  dBmC.

**3 kHz Flat Noise**

- Range (minimum): 20 dBm to 93 dBm.
- Accuracy:  $\pm 1$  dBm.

**3 kHz-Notch Noise (not IEEE-743 measurement)**

- Range: 20 dBm to 93 dBm.
- Accuracy:  $\pm 1$  dBm.



---

---

## SECTION 14

### Echo Return Loss (ERL)

- Range: 0 dB to 50 dB.
- Accuracy:  $\pm 0.5$  dB.

### Singing Return Loss - High/Low (SRL-HI/SRL-LO)

- Range: 0 dB to 50 dB.
- Accuracy:  $\pm 0.5$  dB.

### Peak-to-Average Ratio (P/AR)

- Range: 0 P/AR units to 120 P/AR units.
- Accuracy:  $\pm 2$  P/AR units between 40 P/A and 110 P/AR.  
 $\pm 4$  P/AR units between 0 P/AR and 40 P/AR; and greater than 110 P/AR.

### P/AR Level

- Range: +3.0 dBm to -70.0 dBm.
- Accuracy:  $\pm 0.05$  dBm between +3.0 dBm and -40.0 dBm.  
 $\pm 0.3$  dBm between -40.0 dBm and -70.0 dBm.

### DC Offset (not IEEE-743 measurement)

- Range: -128 mV to +128 mV.
- Accuracy:  $\pm 0.5\%$  or  $\pm 0.5$  mV whichever is greater (scaled to digital mW into 600 ohms).
- Resolution: 1 mV.

**14.9.3 VF Transmitter****Frequency**

- Range: 20 Hz to 3904 Hz.
- Accuracy:  $\pm 0.5$  Hz.
- Resolution: 1 Hz.

**Level**

- Range: +3.0 dBm to -40.0 dBm.
- Accuracy:  $\pm 0.05$  dBm.
- Resolution: 0.1 dBm.

---

---

**SECTION 14**

## **ENHANCED ESF AND SLC-96 OPTION**

### **15.1 INTRODUCTION**

In addition to the current T-BERD 224 capabilities, the Enhanced ESF and SLC-96 Option (ESF/SLC Option) provides additional features, functionality, and capabilities for performing SLC-96 (Subscriber Loop Carrier-96), ESF, and ESFz\* datalink transmission and analysis. This option provides enhancements to the current T1 SLC96, T1 ESF, and T1 ESFz operating modes. Unless otherwise indicated, the previous T-BERD 224 functions and capabilities still apply. Section 15.2, SLC-96 Mode Operation, describes the SLC-96 enhancements. Section 15.6, ESF and ESFz Mode Operation, describes the ESF and ESFz enhancements.

It is assumed that the user has prior knowledge of SLC-96 network configurations, operations, and maintenance procedures.

#### **15.1.1 Standard Features**

When operating in the T1 SLC96 mode, the Enhanced ESF and SLC-96 Option offers the following enhanced features and capabilities:

- Displays SLC-96 shelf A datalink alarm information on the front panel.
- Monitors and transmits SLC-96 datalink major, minor, and power/miscellaneous alarms.
- Monitors SLC-96 datalink for line protection switching messages.
- Monitors and initiates SLC-96 far-end shelf loopbacks.
- Monitors the SLC-96 datalink for maintenance alarm messages.
- Monitors and transmits tri-state SLC-96 A and B signaling bits (included in the standard T-BERD 224 Mainframe).

\*Requires the ZBTISI Option.

---

## SECTION 15

When operating in the T1-ESF or T1-ESFz mode, the ESF/SLC Option offers the following enhanced features and capabilities:

- Reports the ESF and ESFz datalink ANSI T1.403 Performance Report Message (PRM) on the front panel.
- ESF and ESFz datalink PRMs can also be generated and transmitted by the T-BERD 224.
- ESF and ESFz datalink bit oriented protocol (BOP) command response messages and loop codes can be selected and transmitted by the T-BERD 224 (BERT Option required).
- Transmits and detects datalink yellow alarm message (included in the standard T-BERD 224 Mainframe).

### 15.1.2 Optional Features

The following T-BERD 224 options are available and can be used with the Enhanced ESF/SLC Option (Model 11704) installed:

**DSU-DP Option (Model 41441)** — This option adds an EIA RS-232-C and either an EIA RS-449 or CCITT V.35 drop and insert interface for external testing of unformatted fractional T1, DS0A, DS0B, and ESF and ESFz datalink signals. Refer to Section 12, DSU-DP Option, for additional information.

**ZBTSI Framing Option (Model 11425)** — This option allows the T-BERD 224 to test and analyze T1 ESF (Extended Superframe) circuits that use ZBTSI encoding. Refer to Section 11, ZBTSI Framing Option, for additional information.

**VF Option (Model 41502)** — This option enables the T-BERD 224 to perform out-of-service voice frequency (VF) tests that provide measurements of voice-grade noise (C-Message and C-Notch noise), signal-to-noise ratio (S/N), data-grade noise (3 kHz Flat and 3 kHz Notch noise), return loss values (ERL, SRL-HI, and SRL-LO), peak-to-average ratio value (P/AR), DC-offset, and VF frequency and level. Refer to Section 14, VF Option, for a full description of the VF Option.

**T1/Fractional T1/DDS BERT Option (Model 41500)** — This option enables the T-BERD 224 to perform out-of-service bit error rate tests on T1, fractional T1, and DDS circuits with 18 different test patterns;

test both DSOA and DSOB formatted DDS circuits; test both DDS PRIMARY and SECONDARY channels; emulate a T1 CSU by terminating the T1 span and auto-responding to T1 loop codes; measure simplex current and round trip delay, transmit in-band and out-of-band (ESF) loop codes; send both alternating and latching DDS loop codes for sectionalizing and troubleshooting DDS circuits; and insert single, burst, or continuous logic, BPV, and frame errors. Refer to Section 13, Bit Error Rate Test Option, for a full description of the BERT Option.

For additional information on other options, refer to Section 9, Options and Accessories.

## **15.2 SLC-96 MODE OPERATION**

This section describes the controls, indicators, test results, alarms, and operating procedures that are affected by the addition of the ESF/SLC Option to the T-BERD 224 when operating in T1SLC96 operating mode.

### **15.2.1 SLC-96 Mode Functional Description**

The T-BERD 224 can analyze and report on the status of the datalink maintenance, alarm, far-end loopback, and protection line switch fields. The maintenance messages indicate the status of the circuit when channel testing is being performed. The alarm messages indicate varying degrees of system conditions that cause failures in signal quality, loss, or line backup capabilities. The far-end loopback messages indicate which DS1 line is looped back (A, B, C, or D shelf and Protection line). The protection line switch messages indicate which of the primary DS1 data lines has been switched over to the protection line.

When configuring the T-BERD 224 to transmit and receive SLC-96 datalink signals, the T-BERD 224 automatically frames to either the received Network Office Terminating Equipment (NOTE) and WPIB Alarm Control Unit (ACU) 16-bit datalink alarm message format or the WPI ACU 13-bit datalink alarm message format. The NOTE alarm message format provides framing, major alarm, and A, B, C, and D shelf alarm indications. The WPIB and WPI ACU alarm message formats provide framing, major alarm, minor alarm, power/miscellaneous alarm, A, B, C, and D shelf alarm, and A, B, C, D, and protection line far-end loop indications.

---

---

## SECTION 15

The T-BERD 224 only transmits the WP1B ACU datalink alarm message format when the T-BERD 224 line transmitters are connected to the DSX-1. The T-BERD 224 transmits whatever alarm message format it receives. If no alarm message or NOTE is received, the T-BERD 224 defaults to transmit the WP1B ACU 16-bit datalink alarm message format.

The alarm messages are categorized as major and minor alarms. Major alarms identify system failures that prevent subscriber access to the network; i.e., signal loss, datalink failure, loss of frame synchronization, and power/miscellaneous alarms identified as major alarms. Minor alarms identify protection line switching, power/miscellaneous alarms identified as minor alarms, and far-end loops.

The T-BERD 224 can also monitor the channel test procedure that is reported in the datalink maintenance messages (bits M1 to M3). The maintenance messages indicate the sequence of events that take place when a customer loop is connected to the bypass pair.

### 15.2.2 Controls and Indicators

The following controls and indicators affect the operation of the T-BERD 224 when testing T1 SLC-96 circuits with the ESF/SLC Option installed. Table 15-1 indicates the affected switch configurations, selections, and Auxiliary functions, when the ESF/SLC Option is installed. The ESF and ESFz modes are discussed in Section 15.6, ESF and ESFz Mode Operation. Unless otherwise indicated, the switch information described in Section 2, Instrument Description, also applies.

- **MODE** switch
- **CHANNEL FORMAT** switch
- **SOURCE CONFIGURATION I (SCI)** switch
- **SOURCE CONFIGURATION II (SCII)** switch
- **A and B SIGNALING INSERT** switches
- **RESULTS I** switches
- **RESULTS II** switches

**Table 15-1**  
**Enhanced ESF/SLC Option Switch Configurations**

| Switch/Aux Function             | Configuration                                          |                                          |                  |              |
|---------------------------------|--------------------------------------------------------|------------------------------------------|------------------|--------------|
| <b>MODE</b><br>Switch           | T1 SLC96                                               |                                          |                  | ESF or ESFz* |
| <b>CHANNEL FORMAT</b><br>Switch | DATLINK                                                |                                          |                  | **           |
| <b>SCI</b> Switch               | FAR END LP                                             | MAJ ALM                                  | MIN ALM PWR/MISC |              |
| <b>SCII</b><br>Switch           | SHELF A<br>SHELF B<br>SHELF C<br>SHELF D<br>PROTECTION | SHELF A<br>SHELF B<br>SHELF C<br>SHELF D |                  |              |
| AUX 20<br>PRM TX                |                                                        |                                          |                  | X            |

\* Requires ZBTSI Option

\*\* To analyze the PRM, select any channel format.  
See Appendix E for fully optioned T-BERD 224.

A typical T1 SLC-96 front panel display configuration might appear as follows:

|         |            |            |            |
|---------|------------|------------|------------|
| T1SLC96 | F END LOOP | L2 SLC ALM | 279SLC A S |
| DATLINK | PROTECTION | M AJOR     | 34059      |

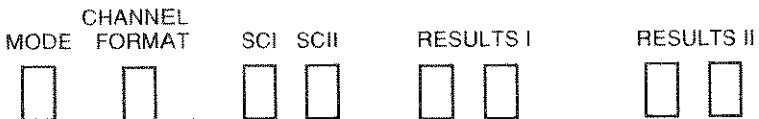



---

---

## SECTION 15

Each display and its switch selections are described in the following sections.

### MODE Switch

In addition to the current T1SLC96 operating mode described in Section 2.3.2, Controls and Indicators (**MODE** Switch [2]), the SLC Option enables the T-BERD 224 to report on the SLC-96 datalink major, minor, far-end loop, power, and miscellaneous alarms. The T-BERD 224 can also transmit the alarms and initiate a far-end loopback.

### CHANNEL FORMAT Switch

To transmit information on the SLC-96 datalink, press the **CHANNEL FORMAT** switch to select the DATLINK channel format. The F END LOOP, MAJOR ALRM, MINOR ALRM, and POWER/MISC source configurations are selectable with the **SCI** switch. The **CHANNEL** switch display is set to dashes (— —) when selecting the DATLINK channel format.

### SOURCE CONFIGURATION I Switch

The following **Source Configuration I (SCI)** switch selections are available when the DATLINK channel format and T1SLC96 operating mode are selected. The **SCI** and **SCII** switches select the type of shelf or protection line message transmitted by the T-BERD 224 over the datalink.

**MAJOR ALRM** — Select the **MAJOR ALRM** source configuration to transmit a major alarm message for either the A, B, C, or D shelf. Press the **SCII** switch to select the SHELFA, B, C, or D major alarm message.

**MINOR ALRM** — Select the **MINOR ALRM** source configuration to transmit a minor alarm message to the far end.

**POWER/MISC** — Select the **POWER/MISC** source configuration to transmit a power/miscellaneous alarm message to the far end.

**F END LOOP** — Select the **F END LOOP** source configuration to transmit a far-end loop code to loopback either the A, B, C, or D shelf, or the protection line. Press the **SCII** switch to select either the A, B, C, or D shelf, or protection loopback code. When the **INSERT** switch is changed from **NONE** to **LINE 1**, the appropriate alarm bits on the **LINE 1** datalink are set to request the selected shelf or protection line to loop the transmitter to the receiver. The **T-BERD 224** also forces the alarm bits on the **LINE 2** datalink to indicate an idle condition (no loop or alarm). When changing the **INSERT** switch to **LINE 2**, the **LINE 2** datalink alarm bits carry the loop or alarm request and the **LINE 1** datalink alarm bits indicate an idle condition. Once the loopback is established, no other datalink tests can be performed until the far-end loop is released.

Depending on the **NOTE** or **ACU** used at the far end, the **T-BERD 224** can transmit the appropriate alarm message. Table 15-2 lists the alarms a **NOTE**, **WP1 ACU**, and **WP1B ACU** can transmit.

**Table 15-2**  
**NOTE and ACU Alarm Messages**

| <b>NOTE</b>   | <b>WP1 ACU</b>               | <b>WP1B ACU</b>                 |
|---------------|------------------------------|---------------------------------|
| Major Alarm   | Major Alarm                  | Major Alarm                     |
| A shelf Alarm | Minor Alarm                  | Minor Alarm                     |
| B shelf Alarm | Power/Misc. Alarm            | Power/Misc. Alarm               |
| C shelf Alarm | A shelf Alarm                | A shelf Alarm                   |
| D shelf Alarm | B shelf Alarm                | B shelf Alarm                   |
|               | C shelf Alarm                | C shelf Alarm                   |
|               | D shelf Alarm                | D shelf Alarm                   |
|               | A Line Far-end Loop          | A Line Far-end Loop             |
|               | B Line Far-end Loop          | B Line Far-end Loop             |
|               | C Line Far-end Loop          | C Line Far-end Loop             |
|               | D Line Far-end Loop          | D Line Far-end Loop             |
|               | Protection Line Far-end Loop | Protection Line<br>Far-end Loop |

## **SOURCE CONFIGURATION II Switch**

The following **SOURCE CONFIGURATION II (SCII)** switch selections are available when the DATLINK channel format, T1SLC96 operating mode, and either the F END LOOP or MAJOR ALRM source configuration are selected:

**SHELF A** — Select **SHELF A** to transmit either the shelf A far-end loop code or major alarm.

**SHELF B** — Select **SHELF B** to transmit either the shelf B far-end loop code or major alarm.

**SHELF C** — Select **SHELF C** to transmit either the shelf C far-end loop code or major alarm.

**SHELF D** — Select **SHELF D** to transmit either the shelf D far-end loop code or major alarm.

**PROTECTION** — Select **PROTECTION** to transmit the protection line far-end loop code. This is the F END LOOP default.

## **RESULTS I and II Switches**

Press the **RESULTS I** and **II Category** switches to select the SUMMARY category where the SLC-96 alarm and protection line switch field status messages appear when the T1SLC96 mode is selected. The SLC alarm seconds result is available from the TIME category. Refer to Section 15.3, SLC-96 Alarms and Measurements, for a list of available result definitions.

**NOTE:** The DATLINK channel format does not need to be selected to monitor the SLC-96 datalink for alarms or other messages.

## **A and B SIGNALING INSERT Switches**

The SLC A and B signaling bits can be set high (1), low (0) or toggled (1 and 0 continuously) by pressing the **A** and **B SIGNALING INSERT** switches while in VF or VF THRU modes. The toggling state is only applicable in T1-D1D and SLC-96 modes. Press the **SIGNALING INSERT** switch for less than 1 second to set the signaling bit to a logic 1

(the switch LED illuminates). Press the switch again to set the signaling bit to a logic 0 (the switch LED is not illuminated). Press the switch for more than 1 second to toggle the signaling bit continuously (the switch LED flashes). The signaling bits are toggled every other superframe. The received signaling bits are monitored through the SIGNAL category 55-TRAFFIC result. Table 15-3 identifies the A and B signaling bit patterns that control SLC channel banks.

**Table 15-3**  
**Signaling States for SLC-96 System Channel Units**

| Channel Unit Type                      | Customer State | Bits Sent To the LDS |   | Bits Sent To the RT |     | Channel State    |
|----------------------------------------|----------------|----------------------|---|---------------------|-----|------------------|
|                                        |                | A                    | B | A                   | B   |                  |
| Single Party                           | On-Hook        | 0                    | 0 | 0                   | 1   | Channel Test     |
|                                        | Off-Hook       | 1                    | 0 | 1                   | 0   | Fwd Disconnect   |
|                                        | Unequipped     | 1                    | 1 | 1                   | 1   | Idle             |
| Superimposed Ringing Multiparty        | On-Hook        | 0                    | 0 | 1                   | 1/0 | -R Ringing       |
|                                        | Tip Prty Gnd   | 0                    | 1 | 0                   | 1   | Channel Test     |
|                                        | Off-Hook       | 1                    | 0 | 1                   | 0   | Tip Party Test   |
|                                        | Unequipped     | 1                    | 1 | 1                   | 1   | Idle             |
|                                        |                |                      |   | 1/0                 | 0   | -R Ringing       |
|                                        |                |                      |   | 1/0                 | 1   | +T Ringing       |
|                                        |                |                      |   | 1/0                 | 1/0 | -T Ringing       |
| Frequency Selective Ringing Multiparty | On-Hook        | 0                    | 0 | 0                   | 1   | Channel Test     |
|                                        | Off-Hook       | 1                    | 0 | 1                   | 1   | Idle             |
|                                        | Unequipped     | 1                    | 1 | 1                   | 1/0 | Freq. Band 1Ring |
|                                        |                |                      |   | 1/0                 | 1/0 | Freq. Band 2Ring |
|                                        |                |                      |   | 1/0                 | 1   | Freq. Band 3Ring |
|                                        |                |                      |   | 1/0                 | 0   | Freq. Band 4Ring |
|                                        |                |                      |   |                     |     |                  |
| Coin                                   | On-Hook        | 0                    | 0 | 0                   | 0   | - Loop Mode      |
|                                        | Coin Gnd       | 0                    | 1 | 0                   | 1   | Channel Test     |
|                                        | Off-Hook       | 1                    | 0 | 1                   | 0   | + Loop Mode      |
|                                        | Unequipped     | 1                    | 1 | 1                   | 1   | Ground Start     |
|                                        |                |                      |   | 0                   | 1/0 | + Coin Check     |
|                                        |                |                      |   | 0                   | 1/0 | -R Ringing       |
|                                        |                |                      |   | 1/0                 | 0   | + Coin Ctrl      |
|                                        |                |                      |   | 1/0                 | 1   | - Coin Ctrl      |
|                                        |                |                      |   | 1/0                 | 1/0 | - Coin Check     |
|                                        |                |                      |   |                     |     |                  |

**Table 15-3**  
**Signaling States for SLC-96 System Channel Units**

| Channel Unit Type     | Customer State  | Bits Sent To the LDS |   | Bits Sent To the RT |     | Channel State |
|-----------------------|-----------------|----------------------|---|---------------------|-----|---------------|
|                       |                 | A                    | B | A                   | B   |               |
| Universal Voice Grade | On-Hook         | 0                    | 0 | 0                   | 0   | Ground Start  |
|                       | Ring Ground     | 0                    | 1 | 0                   | 1   | Channel Test  |
|                       | Off-Hook        | 1                    | 0 | 1                   | 1/0 | -R Ringing    |
|                       | Unequipped      | 1                    | 1 | 0                   | 1/0 | Idle          |
| DID DPT               | Normal Battery  | 0                    | 0 | 0                   | 0   | Loop Open     |
|                       | Reverse Battery | 1                    | 1 | 1                   | 1   | Loop Closure  |
|                       |                 |                      |   |                     |     |               |

**NOTES:**

1. The abbreviation "DID DPT" denotes Direct Inward Dialing Dial Pulse Terminating.
2. The ringing frequencies used in each frequency band are specified in Section 4, TR-TSY-000008.
3. The notation "1/0" indicates alternating ones and zeros.
4. Signaling states not employed by a given channel unit must not be sent to that channel unit.

*Source:* TR-TSY-000008, "Digital Interface Between the SLC 96 Digital Loop Carrier System and a Local Digital Switch," Bell Communications Research, Issue 2, August 1987

## **Local Status and History Indicators**

It should be noted that when frame synchronization is lost and the LOCAL STATUS FRAME SYNC LOSS LED (red FRAME SYNC LED) illuminates, the SLC-96 alarm messages are removed from the SUMMARY category. The Mode III yellow alarm is reported through the LOCAL STATUS YELLOW ALARM LEDs.

## **15.3 SLC-96 ALARMS AND MEASUREMENTS**

The SUMMARY and SIGNAL categories are affected by the SLC portion of the ESF/SLC Option. Unless otherwise indicated, the other categories are also available during testing.

When the T1SLC96 operating mode is selected and the T-BERD 224 is connected to the A shelf; and a new alarm condition, far-end loop, or protection line switchover is detected, the message "Ln SLC DL ALARM" momentarily appears in the front panel display. "Ln" identifies LINE 1 or LINE 2 as the line receiving the SLC datalink alarm. Select the SUMMARY category to determine the nature of the alarm.

### **15.3.1 SUMMARY Category Alarms**

The T-BERD 224 monitors and reports on the SLC-96 datalink maintenance, alarm, and protection line switch fields. The SLC-96 datalink maintenance and alarm messages only appear in the SUMMARY category. Table 15-4 describes each datalink alarm. The alarms appear in the SUMMARY category as they occur. These alarms and messages address the datalink Maintenance (M1 to M3), Alarm (A1 and A2), and Protection line switch (S1 to S4) fields.

The maintenance field (M1 to M3) controls customer loop testing between the Central Office Terminal (COT) and Remote Terminal (RT). This field links the Central Office (CO) pair gain controller access to the customer loop over a bypass pair which bypasses the DS1 circuits. The T-BERD 224 can only monitor the process. The following maintenance messages indicate that the bypass procedure is in progress:

- Ln MAINT HOOK/SEIZE SLC On-Hook/Seize RC (RT to COT) Maintenance Message

---

---

## SECTION 15

- Ln MAINT PROCEED SLC Proceed CR/RC (COT to RT/RT to COT) Maintenance Message
- Ln MAINT TEST ALRM SLC Test Alarm CR/RC Maintenance Message

These messages occur between the COT and RT in approximately 2 seconds. However, if the bypass sequence fails, the Test Alarm CR/RC Message is transmitted. When the pair gain controller initiates the bypass, the COT sends the On-Hook Message to the RT. The RT connects the customer loop to the bypass pair and returns the On-Hook Message to the COT. The COT then sends the Channel Test A and B bit signaling pattern to the RT identifying the channel being bypassed. The RT in turn sends the Seize RC Message to the COT indicating the channel has been switched. After the COT receives the Seize RC Message, it sends a Proceed CR Message to the RT asking if the bypass is complete. If the bypass is complete, the RT returns the Proceed RC Message to the COT. The COT in turn notifies the pair gain controller that the bypass is complete and loop testing can proceed.

The alarm field (A1 and A2) identifies conditions that cause disruptions in customer service, changes in signal quality, changes in signal path, and mechanical integrity of the system. The alarms are generally classified as major and minor alarms.

Major alarms indicate system failures that cause disruptions in customer service. These failures include excessive BPVs, frame loss, and continuous signal loss. Minor alarms indicate system conditions that occur to prevent a major alarm or identify a far-end loop. The T-BERD 224 displays the following alarms:

- Ln SLC ALM MAJOR SLC Major Alarm
- Ln SLC ALM SHELF (x) SLC Shelf Alarm
- Ln SLC ALM POWER/MISC SLC Power/Miscellaneous Alarm
- Ln SLC ALM MINOR SLC Minor Alarm
- Ln FE LOOP PROTECTION SLC Protection Line Far-End Loop Alarm

- Ln FE LOOP SHELF (x)      SLC Shelf Far-End Loop Alarm
- Ln SLC ALM (x) ON PROT      SLC Shelf on Protection Line Alarm

These alarms are removed from the SUMMARY category when signal or frame loss occurs. Pattern loss does not affect the alarms.

**Table 15-4**  
**SUMMARY Category Results**

| Results Name           | Description                                                                                                                                                               |
|------------------------|---------------------------------------------------------------------------------------------------------------------------------------------------------------------------|
| Ln FE LOOP PROTECTION  | SLC Protection Line Far-End Loop Alarm — A state in which the protection line is in loopback.                                                                             |
| Ln FE LOOP SHELF (x)   | SLC Shelf Far-End Loop Alarm — A shelf state in which the indicated DSI shelf is in loopback. (x) indicates which shelf (A, B, C or D) is looped.                         |
| Ln MAINT HOOK/SEIZE    | SLC On-Hook/Seize RC Maintenance Message — This message appears when either the On-hook or Seize RC message is received.                                                  |
| Ln MAINT PROCEED       | SLC Proceed CR/RC Maintenance Message — Receiving the message from the COT, the COT is asking to proceed. Receiving the message from the RT, the RT is ready to continue. |
| Ln MAINT TEST ALRM     | SLC Test Alarm CR/RC Maintenance Message — Either the COT or the RT has failed the bypass procedure.                                                                      |
| Ln SLC ALM (x) ON PROT | SLC Shelf on Protection Line Alarm — A shelf DSI is switched over to the protection line. (x) indicates which shelf (A, B, C or D) is switched to the protection line.    |



**Table 15-4**  
**SUMMARY Category Results (Continued)**

| Results Name          | Description                                                                                                                                                                                                          |
|-----------------------|----------------------------------------------------------------------------------------------------------------------------------------------------------------------------------------------------------------------|
| Ln SLC ALM MAJOR      | SLC Major Alarm — A system state characterized by a loss of service to subscribers served by a shelf or shelf group exists.* If a shelf alarm (Ln SLC ALM SHELF (x)) is also reported, this result is not displayed. |
| Ln SLC ALM MINOR      | SLC Minor Alarm — A system state characterized by a non-service affecting fault exists.* If a far-end loop alarm message is reported for the same line (L1 or L2), this message is not displayed.                    |
| Ln SLC ALM POWER/MISC | SLC Power/Miscellaneous Alarm — An RT state in which losing power or miscellaneous conditions have occurred.                                                                                                         |
| Ln SLC ALM SHELF (x)  | SLC Shelf Alarm — A system state characterized by a shelf's loss of operational integrity.* (x) indicates the shelf (A, B, C or D) generating the shelf alarm.                                                       |

\* Source: TR-TSY-000008, "Digital Interface Between the SLC 96 Digital Loop Carrier System and a Local Digital Switch," Bell Communications Research, Issue 2, August 1987.

### **15.3.2 TIME Category Measurements**

When selecting the T1SLC96 mode, the TIME category results include the SLC alarm seconds (n79SLC A S) result. This result identifies the test seconds in which detection of datalink alarms, far-end loop, or protection line switching conditions occurs. The maintenance messages do not increment the result. The availability of the result occurs after achieving datalink alarm frame synchronization. Signal loss and frame loss freeze the result until signal and frame synchronization is achieved. Pattern loss has no effect on the result.

## **15.4 SLC-96 MODE TESTING**

The following procedures describe the test capabilities provided by the SLC portion of the ESF/SLC Option. These test procedures demonstrate how the T-BERD 224 can monitor SLC-96 alarms, maintenance activity, protection line switching, and far-end loop activity; dial into a CO switch from a T1 SLC-96 access point; and loop a SLC shelf with the T-BERD 224 and test the looped shelf with an external test set.

### **15.4.1 Monitoring the SLC-96 Datalink**

This procedure describes how the T-BERD 224 is connected to a SLC-96 system DSX-1 patch panel to monitor the A shelf datalink from the RT and COT. Figure 15-1 illustrates how the T-BERD 224 is connected to the span through the DSX-1 patch panel and setup in a monitor connection. Table 15-5 configures the T-BERD 224 to monitor the A shelf datalink for SLC-96 alarms, maintenance activity, protection line switching, and far-end loop activity.

**NOTE:** This is an in-service test procedure and does not interfere with normal operation.

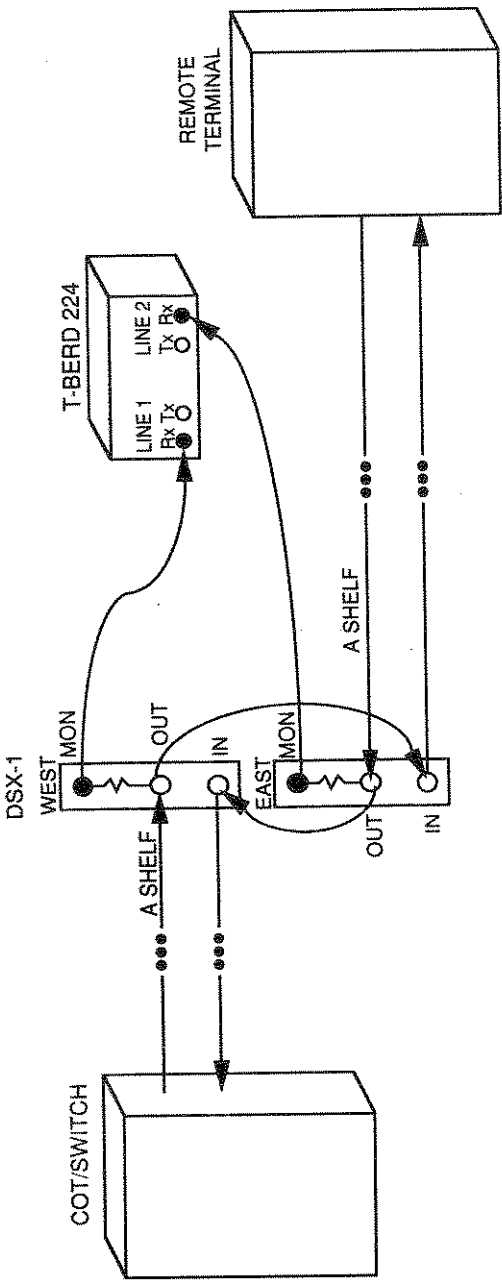

Figure 15-1  
Connections for Monitoring the SLC-96 Datalink

**Table 15-5**  
**Test Set-Up for Monitoring the SLC-96 Datalink**

| <b>Step</b> | <b>Controls/Indicators/<br/>Connections</b>                                       | <b>Activity</b>                                                                                                                                                                                                                                                                                                                                                                                                                              |
|-------------|-----------------------------------------------------------------------------------|----------------------------------------------------------------------------------------------------------------------------------------------------------------------------------------------------------------------------------------------------------------------------------------------------------------------------------------------------------------------------------------------------------------------------------------------|
| 1.          | T1 Circuit Connections                                                            | <p>Perform the procedure in Section 4.2.1, T1 Circuit Monitoring, to connect the T-BERD 224 to the T1 circuit to monitor the SLC-96 datalink with the following switch settings:</p> <ul style="list-style-type: none"> <li>(a) <b>MODE</b> switch is set to T1SLC96.</li> <li>(b) <b>CHANNEL FORMAT</b> switch is set to the applicable format.</li> <li>(c) <b>SCI</b> and <b>SCII</b> switches are not required for this test.</li> </ul> |
| 2.          | <b>RESULTS I &amp; II</b> switches                                                | <ul style="list-style-type: none"> <li>(a) Display <b>SUMMARY</b> category in the <b>RESULTS I</b> display.</li> <li>(b) Display <b>SIGNAL</b> category, n79SLC A S result, in the <b>RESULTS II</b> display. <b>LINE 1</b> receives the results from the <b>COT</b>. <b>LINE 2</b> receives the results from the <b>RT</b>.</li> </ul>                                                                                                      |
| 3.          | <b>DISPLAY HOLD, LOOP CODES, AUX, SIGNALING INSERT, and ERROR INSERT</b> switches | Verify that all switches are released (switch LEDs are extinguished).                                                                                                                                                                                                                                                                                                                                                                        |
| 4.          | <b>TEST</b> switch                                                                | Set to <b>CONT.</b> testing, as required.                                                                                                                                                                                                                                                                                                                                                                                                    |
| 5.          | <b>CODE</b> switch                                                                | Set to <b>AMI</b> coding.                                                                                                                                                                                                                                                                                                                                                                                                                    |
| 6.          | <b>LINE 1 RESULTS</b> Verification                                                | <p>Check the <b>SUMMARY</b> category for one or more of the following:</p> <ul style="list-style-type: none"> <li>(a) <b>RESULTS OK</b> - No alarms, maintenance activity, far-end loops, or protection line switching found. No signal errors found, span operational.</li> </ul>                                                                                                                                                           |

**Table 15-5**  
**Test Set-Up for Monitoring the SLC-96 Datalink (Continued)**

| Step | Controls/Indicators/<br>Connections | Activity                                                                                                                                                                                                                                                                                                                                                                                                                                                                                                                                                                                                                                                                                                                                                                                                                                                                                                                                                                                                                                                                                                                                                                                                                                                                                                                                                                                                                                                   |
|------|-------------------------------------|------------------------------------------------------------------------------------------------------------------------------------------------------------------------------------------------------------------------------------------------------------------------------------------------------------------------------------------------------------------------------------------------------------------------------------------------------------------------------------------------------------------------------------------------------------------------------------------------------------------------------------------------------------------------------------------------------------------------------------------------------------------------------------------------------------------------------------------------------------------------------------------------------------------------------------------------------------------------------------------------------------------------------------------------------------------------------------------------------------------------------------------------------------------------------------------------------------------------------------------------------------------------------------------------------------------------------------------------------------------------------------------------------------------------------------------------------------|
| 7.   | LINE 2 RESULTS<br>Verification      | <p>(b) SLC-96 COT status. Monitor for any of the following results:</p> <ul style="list-style-type: none"> <li>LI FE LOOP PROTECTION</li> <li>LI FE LOOP SHELF (x)</li> <li>LI MAINT HOOK/SEIZE</li> <li>LI MAINT PROCEED</li> <li>LI MAINT TEST ALRM</li> <li>LI SLC ALM (x) ON PROT</li> <li>LI SLC ALM MAJOR</li> <li>LI SLC ALM MINOR</li> <li>LI SLC ALM POWER/MISC</li> <li>LI SLC ALM SHELF (x)</li> </ul> <p>(c) Errored Results - non-zero or out of specification results:</p> <ul style="list-style-type: none"> <li>125-BPVS               <ul style="list-style-type: none"> <li>BPV &amp; FRAME Category</li> </ul> </li> <li>130-FRM ERR               <ul style="list-style-type: none"> <li>BPV &amp; FRAME Category</li> </ul> </li> <li>134-FRM LOS               <ul style="list-style-type: none"> <li>BPV &amp; FRAME Category</li> </ul> </li> <li>140-RX FREQ               <ul style="list-style-type: none"> <li>SIGNAL Category</li> </ul> </li> <li>151-TM SLIP               <ul style="list-style-type: none"> <li>SIGNAL Category</li> </ul> </li> </ul> <p>Further sectionalization is required. If necessary, reestablish the loopback at another point along the span and repeat the test.</p> <p>Check the SUMMARY category for one or more of the following:</p> <p>(a) RESULTS OK - No alarms, maintenance activity, far-end loops, or protection line switching found. No signal errors found, span operational.</p> |

**Table 15-5**  
**Test Set-Up for Monitoring the SLC-96 Datalink (Continued)**

| Step | Controls/Indicators/<br>Connections | Activity                                                                                                                                                                                                                                                                                                                                                                                                                                                                                                                                                                                                                                                                                                                                                                  |
|------|-------------------------------------|---------------------------------------------------------------------------------------------------------------------------------------------------------------------------------------------------------------------------------------------------------------------------------------------------------------------------------------------------------------------------------------------------------------------------------------------------------------------------------------------------------------------------------------------------------------------------------------------------------------------------------------------------------------------------------------------------------------------------------------------------------------------------|
|      |                                     | <p>(b) SLC-96 RT status. Monitor for any of the following results:</p> <p>L2 FE LOOP PROTECTION<br/> L2 FE LOOP SHELF (x)<br/> L2 MAINT HOOK/SEIZE<br/> L2 MAINT PROCEED<br/> L2 MAINT TEST ALRM<br/> L2 SLC ALM (x) ON PROT<br/> L2 SLC ALM MAJOR<br/> L2 SLC ALM MINOR<br/> L2 SLC ALM POWER/MISC<br/> L2 SLC ALM SHELF (x)</p> <p>(c) Errored Results - non-zero or out of specification results:</p> <p>225-BPVS<br/> BPV &amp; FRAME Category<br/> 230-FRM ERR<br/> BPV &amp; FRAME Category<br/> 234-FRM LOS<br/> BPV &amp; FRAME Category<br/> 240-RX FREQ<br/> SIGNAL Category<br/> 251-TM SLIP<br/> SIGNAL Category</p> <p>Further sectionalization is required. If necessary, reestablish the loopback at another point along the span and repeat the test.</p> |

---

---

## SECTION 15

### 15.4.2 Dialing Into the Central Office Switch

This procedure describes how the T-BERD 224 is connected to a SLC-96 system DSX-1 patch panel to dial through the CO switch from the T-BERD 224 on a selected channel. The drop and insert test connections shown in Figure 15-2 illustrate how the T-BERD 224 connects to the span to allow the other VF channels to be passed through unaffected. It also shows a telephone butt set connected to the T-BERD 224 to allow 2-way voice access to the selected channel. Table 15-6 configures the T-BERD 224 to select a SLC-96 shelf line channel on which to dial through and test.

**NOTE:** A telephone butt set is required to perform this procedure. This is an out-of-service test procedure on the selected channel and does not interfere with the normal operation of the other shelves.

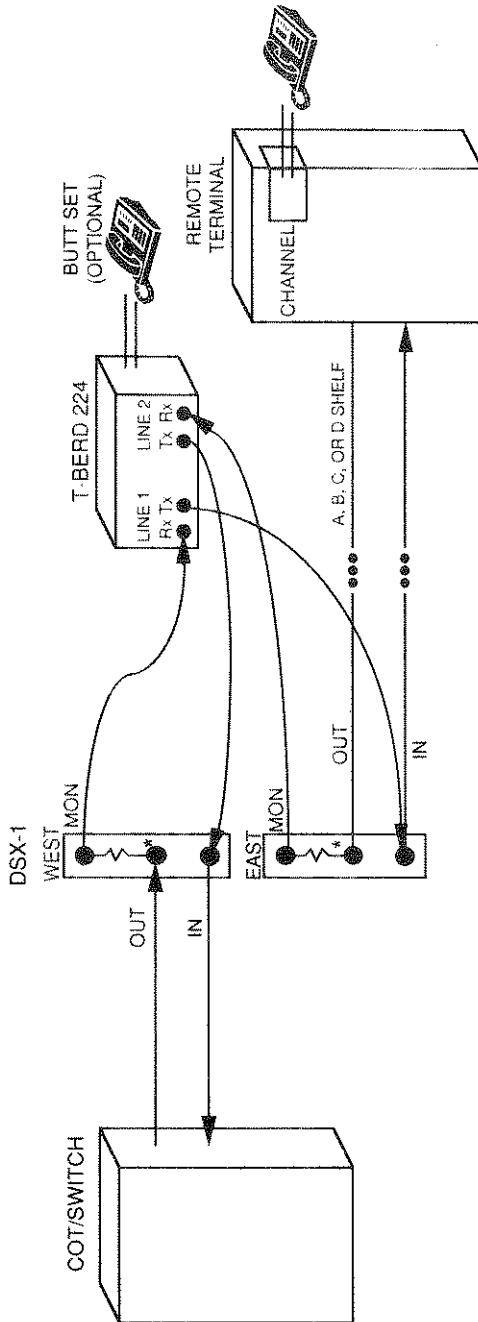

\*100-OHM TERMINATING PLUG

Figure 15-2  
Connections for Dialing Into the CO Switch



**Table 15-6**  
**Test Set-Up for Dialing Into the CO**

| Step | Controls/Indicators/<br>Connections                                               | Activity                                                                                                                                                                                                                                                                                                                                                                                                                                                              |
|------|-----------------------------------------------------------------------------------|-----------------------------------------------------------------------------------------------------------------------------------------------------------------------------------------------------------------------------------------------------------------------------------------------------------------------------------------------------------------------------------------------------------------------------------------------------------------------|
| 1.   | T1 Circuit<br>Connections                                                         | <p>Perform the procedure in Section 4.2.2, Drop and Insert Testing, to connect the T-BERD 224 to the T1 circuit to drop and insert a specific channel from a selected shelf line with the following switch settings:</p> <p>(a) <b>MODE</b> switch is set to T1SLC96 (A shelf) or T1 D1D (B, C, or D shelf).</p> <p>(b) <b>CHANNEL FORMAT</b> switch is set to VF.</p> <p>(c) <b>SCI</b> switch set to VF INTF to select the side panel VF 2-WIRE INTF terminals.</p> |
| 2.   | <b>RESULTS I</b> switches                                                         | Display SIGNAL category in the RESULTS I display. Select the n55 TRAFFIC result to display the A and B signaling bits.                                                                                                                                                                                                                                                                                                                                                |
| 3.   | <b>DISPLAY HOLD, LOOP CODES, AUX, SIGNALING INSERT, and ERROR INSERT</b> switches | Verify that all switches are released (switch LEDs are extinguished).                                                                                                                                                                                                                                                                                                                                                                                                 |
| 4.   | <b>VOLUME</b> switch                                                              | Set to mid range.                                                                                                                                                                                                                                                                                                                                                                                                                                                     |
| 5.   | <b>TEST</b> switch                                                                | Set to CONT. testing, as required.                                                                                                                                                                                                                                                                                                                                                                                                                                    |
| 6.   | <b>CODE</b> switch                                                                | Set to AMI coding.                                                                                                                                                                                                                                                                                                                                                                                                                                                    |
| 7.   | Side panel VF 2-WIRE INTF terminals                                               | Connect the telephone butt set to the interface.                                                                                                                                                                                                                                                                                                                                                                                                                      |

**Table 15-6**  
**Test Set-Up for Dialing Into the CO (Continued)**

| Step | Controls/Indicators/<br>Connections      | Activity                                                                                                                                                                  |
|------|------------------------------------------|---------------------------------------------------------------------------------------------------------------------------------------------------------------------------|
| 8.   | <b>DROP</b> switch                       | Set to LINE 1 (LINE 1 LED illuminates). Monitor the shelf channel signaling activity from the COT and listen to channel through the telephone butt set (see Figure 15-2). |
| 9    | <b>INSERT</b> switch                     | Set to LINE 2 (LINE 2 LED illuminates). This enables 2-way access to the telephone butt set.                                                                              |
| 10.  | <b>A and B SIGNALING INSERT</b> switches | Place selected channel off-hook, A = 1 and B = 0 (see Table 15-3).                                                                                                        |
| 11.  | Telephone butt set                       | (a) Verify that dial tone is heard (loop start).<br><br>(b) Dial test telephone number.<br><br>(c) Verify ring back and far-end party answering call.                     |
| 12.  | 55 TRAFFIC result                        | Verify A and B signaling responses from COT.                                                                                                                              |
| 13.  | <b>A and B SIGNALING INSERT</b> switches | Place selected channel on-hook, A = 0 and B = 0 (see Table 15-3).                                                                                                         |

### 15.4.3 Looping and Testing SLC Shelf Lines

This procedure describes how the T-BERD 224 is connected to a SLC-96 system DSX-1 patch panel to loop the selected shelf line and test the looped line with an external test set. The drop and insert test connections shown in Figure 15-3 illustrate how the T-BERD 224 is connected to the A shelf without affecting the span. Figure 15-3 also shows where the external test set is connected across the looped line. Table 15-7 configures the T-BERD 224 to loop the SLC-96 shelf line.

**NOTE:** This procedure only takes one shelf out of service at a time.

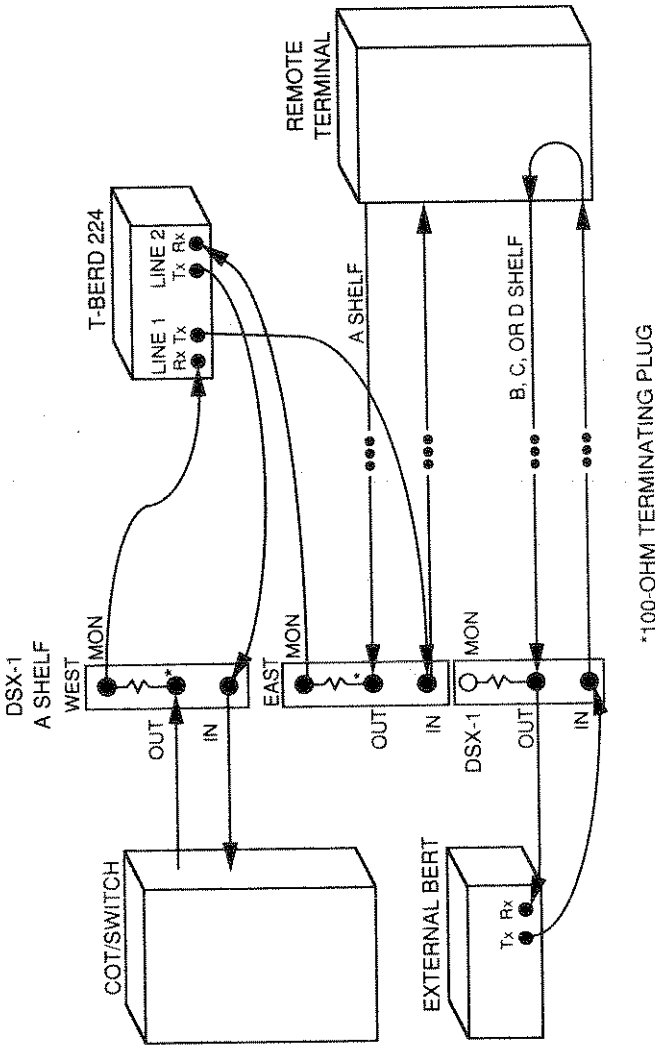

\*100-OHM TERMINATING PLUG

Figure 15-3  
Connections for Looping and Testing a Shelf Line

**Table 15-7**  
**Test Set-Up for Looping the Shelf Line**

| Step | Controls/Indicators/<br>Connections                                               | Activity                                                                                                                                                                                                                                                                                                                                                                                                                                                                                                                                    |
|------|-----------------------------------------------------------------------------------|---------------------------------------------------------------------------------------------------------------------------------------------------------------------------------------------------------------------------------------------------------------------------------------------------------------------------------------------------------------------------------------------------------------------------------------------------------------------------------------------------------------------------------------------|
| 1.   | T1 Circuit Connections                                                            | <p>Perform the procedure in Section 4.2.2, Drop and Insert Testing, to connect the T-BERD 224 to the T1 circuit to control a selected shelf line with the following switch settings:</p> <ul style="list-style-type: none"> <li>(a) <b>MODE</b> switch is set to T1SLC96.</li> <li>(b) <b>CHANNEL FORMAT</b> switch is set to DATLINK.</li> <li>(c) <b>SCI</b> switch set to FAR END LP to loop up the selected shelf (see <b>SCII</b> switch).</li> <li>(d) <b>SCII</b> switch set to SHELF C to select the shelf to be looped.</li> </ul> |
| 2.   | <b>RESULTS I</b> switches                                                         | Display SUMMARY category in the RESULTS I display.                                                                                                                                                                                                                                                                                                                                                                                                                                                                                          |
| 3.   | <b>DISPLAY HOLD, LOOP CODES, AUX, SIGNALING INSERT, and ERROR INSERT</b> switches | Verify that all switches are released (switch LEDs are extinguished).                                                                                                                                                                                                                                                                                                                                                                                                                                                                       |
| 4.   | <b>TEST</b> switch                                                                | Set to CONT. testing, as required.                                                                                                                                                                                                                                                                                                                                                                                                                                                                                                          |
| 5.   | <b>CODE</b> switch                                                                | Set to AMI coding.                                                                                                                                                                                                                                                                                                                                                                                                                                                                                                                          |
| 6.   | <b>INSERT</b> switch                                                              | Set to LINE 2 (LINE 2 LED illuminates). This enables the loop code to be transmitted over the A shelf datalink. After a 3 second delay the loop code is transmitted.                                                                                                                                                                                                                                                                                                                                                                        |
| 7.   | <b>RESULTS I</b> Verification                                                     | Verify that the RESULTS I display now shows "LI SLC ALM C ON PROT". If not, force a protection switch by plugging a terminating plug into the C shelf's jack.                                                                                                                                                                                                                                                                                                                                                                               |
| 8.   | External Test Set                                                                 | Connect to C shelf and perform required testing.                                                                                                                                                                                                                                                                                                                                                                                                                                                                                            |

---

---

**SECTION 15****15.5 SLC-96 MODE REMOTE CONTROL COMMANDS**

Refer to Section 6, Remote Control Operation, for complete information on the setup and operation of the T-BERD 224 from a remote control device. This section identifies error messages and remote control commands that are added when the ESF/SLC Option is installed.

**15.5.1 Remote Control Error Messages**

Refer to Section 6.4, Error Messages, for additional error messages.

**15.5.2 Remote Control Commands**

Table 15-8 lists the available remote control commands that enable control of the SLC portion of the ESF/SLC Option from a remote device. The remote control commands are described in the following sections. Refer to Section 6.5, Remote Control Commands, for the standard remote control commands.

**Table 15-8**  
**SLC-96 Mode Remote Control Commands**

| <b>Command</b>   | <b>Command Name</b>               |
|------------------|-----------------------------------|
| CHA FOR [ ]*     | Set Channel Format                |
| FAR END LOO      | Far-End Loopback Status           |
| MOD [ ]*         | Transmit and Receive Mode         |
| PRI*             | Initiate Printout                 |
| RES 1 and 2 [ ]* | Result Display Control            |
| SIG INS [ ]*     | Channel Signaling Bit Insert      |
| SLC ALA          | SLC Alarm Status                  |
| SLC MAINT        | SLC Maintenance Message Status    |
| SOU 1 [ ]*       | Source Configuration 1            |
| SOU 2 [ ]*       | Source Configuration 2            |
| SUMMARY*         | Print Results in Summary Category |

\* Available with the T-BERD 224 Mainframe.

CHA FOR

CHA FOR

Channel Format

**CHA FOR?**

:Displays the current channel format

**CHA FOR DAT LIN**

:Enables access to the SLC-96 datalink when the T1SLC96 mode is selected (see MODE command). In SLC mode this allows transmission of far-end loop codes, major alarms, minor alarms and power/miscellaneous alarms

**CHA FOR (parameter)**

:Sets the channel format to the (parameter) value

The **CH**annel **FOR**mat parameter, **DATA LINK**, applies to the T1SLC96 mode. Refer to Section 6.5, Remote Control Commands, for additional **CH**annel **FOR**mat commands to test the T1 signals. This command is identical to pressing the **CHANNEL FORMAT** switch.

**NOTE:** Changing the channel format causes a test restart and changes the current front panel configuration to the previous configuration of the selected channel format. A warning is printed indicating the new setup (see **EXAMPLE**).

See also: **FAR END LOO, PRI, RES 1/2, SIG INS, SLC ALA, SLC MAINT, SOU 1, and SOU 2**

EXAMPLE:

```
> CHA FOR? :display the current channel format
 CHAnnel FORmat VF THRU
> CHA FOR DAT LIN :select DATLINK as the channel format
```

WARNING: New Setup:

```
 MODe T1SLC
 CHAnnel FORmat DATA LINK
 SOUrcE 1 FAR END LOOp
 SOUrcE 2 PROtEction
```

&gt;

---

---

**SECTION 15**

**FAR END LOO**

**FAR END LOO**

**Far-End Loopback Status**

**FAR END LOO?** :Reports the status of the shelf and protection line far-end loopbacks of both lines

**SHELF A, B, C, or D** — shelf A, B, C, or D is in far-end loop.

**PROTECTION** — The protection line is in far-end loop.

**UNAVAIL** — The datalink is not being received, e.g., frame synchronization is not established or the line receiver is not connected to the span.

**N/A** — Command is not applicable to current configuration.

**NONE** — None of the DS1 lines is looped back.

See also: **CHA FOR, PRI, RES 1/2, SIG INS, SLC ALA, SLC MAINT, SOU 1, and SOU 2**

**EXAMPLE:**

**> FAR END LOO?** :display current far-end loop status

**LINE 1 SLC FAR END LOOP:**

**SHELF A** :Shelf A is in a far-end loopback

**LINE 2 SLC FAR END LOOP:**

**SHELF A** :Shelf A is in a far-end loopback

**>**

**PRI****PRI**

Initiate Printout

**PRI [CON|RES|parameter]** :Initiate controls or results printout**PRI SLC ASn?** :Initiates a results printout for the SLC alarm seconds result (n79SLC A S). n = LINE "1" or LINE "2"

The **PRI** parameter, **SLC ASn?**, is only available when the T1 SLC96 mode is selected and datalink frame synchronization is established. If the result is not available or not applicable one of the following appears:

**UNAVAIL** — The T1 SLC96 mode is selected but the datalink frame synchronization is not established.

**N/A** — The T1 SLC96 mode is not selected.

Refer to Section 6.5, Remote Control Commands, for additional **PRI** results.

See also: **CHA FOR, FAR END LOO, MOD, RES 1/2, SIG INS, SLC ALA, SLC MAINT, SOU 1, SOU 2, CONTROLS, and RESULTS**

EXAMPLE:

```
> PRI SLC AS1? :print the SLC alarm second result for
 LINE 1
 SLC AS1 29394 :29394 alarm seconds are detected on
 LINE 1
>
```



---

---

**SECTION 15****RES 1 and 2****RES 1 and 2****Result Display Control**

**RES [1|2]?** :Prints the displayed result in the Results I or II display

**RES 1 SLC ASn** :Display SLC alarm seconds result (n79SLC A S) in Results I display

**RES 2 SLC ASn** :Display SLC alarm seconds result (n79SLC A S) in Results II display

Unlike the **PRINT** command, the **RES** command calls up the specified results in the Results displays. The specified result is not displayed at the remote control unit. This command is only valid when the T1SLC96 mode is selected. This command is identical to pressing the **RESULTS I or II Results** switch when the **AUX** switch LED is not illuminated.

See also: **CHA FOR, FAR END LOO, MOD, PRI, SIG INS, SLC ALA, SLC MAINT, SOU 1, SOU 2, and PRINT**

**EXAMPLE:**

> **RES 1 SLC AS1** :display 179SLC A S result for LINE 1 in the Results I display

> **RES 1?** :print the current result in the Results I display

SLC AS1 3920349

>

SIG INS

SIG INS

## Channel Signaling Bit Insert

|                         |                                                                                                                                                                                                                                                                     |
|-------------------------|---------------------------------------------------------------------------------------------------------------------------------------------------------------------------------------------------------------------------------------------------------------------|
| <b>SIG INS n?</b>       | :Displays the current logical state of the selected signaling bit where <b>n</b> = A, B, or ALL                                                                                                                                                                     |
| <b>SIG INS n OFF</b>    | :Sets the selected signaling bit to a continuous logic 0 where <b>n</b> = A or B                                                                                                                                                                                    |
| <b>SIG INS n ON</b>     | :Sets the selected signaling bit to a continuous logic 1 where <b>n</b> = A or B                                                                                                                                                                                    |
| <b>SIG INS n T</b>      | :Sets the selected signaling bit to a continuous toggling 1/0 state where <b>n</b> = A or B                                                                                                                                                                         |
| <b>SIG INS ALL [AB]</b> | :Sets the logic state for all signaling bits in the indicated states. <b>A</b> = A signaling bit and <b>B</b> = B signaling bit. Replace the <b>A</b> and <b>B</b> with either a 1, 0, or T to set the signaling bit to a logic 1 or 0 or Toggle all signaling bits |

This command performs the same function as the **SIGNALING INSERT** switches. Refer to Table 15-3 for a list of the signaling states for SLC-96 system channel units. Perform the following steps before initiating the channel signaling bit insert function:

- (1) Set the **INSert** command to either **L1** or **L2**.
- (2) Set the **L1/2 CHAnnel** command to either the desired channel number (1 to 24) or **ALL**.
- (3) Set the **CHAnnel FORmat** command to **VF**.

---

---

**SECTION 15**

**SIG INS**

**SIG INS**

**Channel Signaling Bit Insert (Continued)**

Requesting the status of the **SIGNALING INSERT** switches can be performed at any time.

See also: **CHA FOR, FAR END LOO, MOD, PRI, RES 1/2, SLC ALA, SLC MAINT, SOU 1, and SOU 2**

**EXAMPLE 1:**

- > **SIG INS A ON** :set the A signaling bit to a logic 1 (ON). The **A SIGNALING INSERT** switch illuminates.
- > **SIG INS A?** :display the current logical state of the A signaling bit
- SIGnal INSert A ON

>

**EXAMPLE 2:**

- > **SIG INS ALL?** :display the current logical state of the signaling bits
- SIGnal INSert ALL 10
- > **SIG INS ALL 1T** :set the A signaling bit to a logic 1 and toggle the B signaling bit (1/0). The **A SIGNALING INSERT** switch illuminates and the **B SIGNALING INSERT** switch flashes.

>

**EXAMPLE 3:**

- > **SIG INS ALL TT** :toggle both signaling bits (1/0). The **A** and **B SIGNALING INSERT** switches flash

>

**SLC ALA****SLC ALA****SLC Alarm Status**

**SLC ALA?** :Display the current SLC alarm conditions on both lines

These alarms also appear in the SUMMARY category. The following alarm conditions are reported:

**SHELF A, B, C, or D** — A shelf alarm occurred.

**MAJOR** — A major alarm occurred.

**MINOR** — A minor alarm occurred.

**POWER MISC.** — A power/miscellaneous alarm occurred.

**A, B, C, or D ON PROT.** — The indicated shelf switched to the protection Line.

**FE LOOP SHELF A, B, C, or D** — The indicated shelf is in a far-end loop.

**FE LOOP PROTECTION** — The protection line is in a far-end loop.

**UNAVAIL** — The T1 SLC96 mode is selected, but datalink frame synchronization is not established.

**N/A** — The T1 SLC96 mode is not selected.

**NONE** — Appears when no alarms are reported.

See also: **CHA FOR, FAR END LOO, MOD, PRI, RES 1/2, SIG INS, SLC MAINT, SOU 1, and SOU 2**

---

---

**SECTION 15**

**SLC ALA**

**SLC ALA**

**SLC Alarm Status (Continued)**

**EXAMPLE:**

**> SLC ALA?** :report on current SLC alarms

**LINE 1 SLC ALARMS:**

SHELF A

MAJOR

POWER MISC.

LINE 1 reports a major alarm on shelf A and a power failure

**LINE 2 SLC ALARMS:**

SHELF A

MAJOR

POWER MISC.

B ON PROT

LINE 2 reports a major alarm on shelf A and a power failure. Shelf B has switched to the Protection Line.

**>**

SLC MAINT

SLC MAINT

## SLC Maintenance Message Status

**SLC MAINT?** :Reports on the status of the datalink maintenance messages

This command is only valid when the T1SLC96 mode and the DATLINK channel format are selected and frame synchronization is established. These messages also appear in the SUMMARY category. The following reports appear by line number (see EXAMPLE):

**HOOK/SEIZE** — On-Hook/Seize RC/CR message received.

**PROCEED** — Proceed RC/CR message received.

**TEST ALARM** — Test alarm message received.

**UNAVAIL** — The T1 SLC96 mode is selected, but datalink frame synchronization is not established.

**N/A** — The T1 SLC96 mode is not selected.

**NONE** — None of the maintenance messages is reported.

See also: **CHA FOR, FAR END LOO, MOD, PRI, RES 1/2, SIG INS, SLC ALA, SOU 1, and SOU 2**

## EXAMPLE:

> **SLC MAINT?** :display current maintenance bit status

LINE 1 SLC MAINTENANCE:

HOOK/SEIZE

PROCEED

LINE 2 SLC MAINTENANCE:

UNAVAIL

>

---

---

## SECTION 15

SOU 1

SOU 1

### Set Source Configuration I

- SOU 1?** :Displays the current source configuration I selection
- SOU 1 FAR END LOO** :Sends a far-end loop command to the selected shelf (**SOU 2** set to **SHELF A, B, C, or D**) or Protection line (**SOU 2** set to **PROtection**)
- SOU 1 MAJ ALA** :Sends a major alarm to the selected shelf (**SOU 2** set to **SHELF A, B, C, or D**)
- SOU 1 MINO ALA** :Sends a minor alarm
- SOU 1 POW** :Sends a power/miscellaneous alarm

These **SOU 1** parameters (**FAREND LOO, MAJ ALA, MINO ALA, and POW**) are only valid when the T1SLC96 mode and DATLINK channel format are selected and frame synchronization is established. Refer to Section 6.5, Remote Control Commands, for additional **SOU 1** parameters. This command is identical to pressing the **SCI** switch.

**NOTE:** Changing the source configuration causes a test restart and changes the current front panel configuration to the previous configuration of the selected channel format. A warning is printed indicating the new set up (see **EXAMPLE**).

See also: **CHA FOR, FAR END LOO, MOD, PRI, RES 1/2, SIG INS, SLC ALA, SLC MAINT, and SOU 2**

#### EXAMPLE:

- > **SOU 1?** :display the current **SCI** selection  
    SOUrce 1 MINor ALArM
- > **SOU 1 MAJ ALA** :select the major alarm message as the  
    new source configuration

WARNING: New Setup:

    MODE T1SLC  
    CHAnnel FORmat DATa LINK  
    SOUrce 1 MAJor ALArM  
    SOUrce 2 SHElf A

>

SOU 2

SOU 2

## Source Configuration II

- SOU 2?** :Displays the current **SCII** selection
- SOU 2 SHE [A|B|C|D]** :Selects the shelf to which either the **SOU 1 FAR END LOO** or **SOU 1 MAJ ALA** selection is sent
- SOU 2 PRO** :Selects the **PRO**tection line to which the **SOU 1 FAR END LOO** selection is sent

These **SOU 2** parameters (**SHELF [A|B|C|D]** and **PRO**) are only valid when the T1SLC96 mode and the DATLINK channel format are selected. This command is identical to pressing the **SCII** switch. Refer to Section 6.5, Remote Control Commands, for additional **SOU 2** parameters.

**NOTE:** Changing the source configuration causes a test restart and changes the current front panel configuration to the previous configuration of the selected channel format. A warning is printed indicating the new set up (see **EXAMPLE**).

See also: **CHA FOR, FAR END LOO, MOD, PRI, RES 1/2, SIG INS, SLC ALA, SLC MAINT,** and **SOU 1**

**EXAMPLE:**

- > **SOU 2?** :display the current **SOU 2** selection  
     **SOUR**ce 2 **SHElf** D
- > **SOU 2 PRO** :select the **PRO**tection line to which the **SOU 1 FAR END LOO** is sent

**WARNING:** New Setup:  
**MODe** T1SLC  
**CHAnnel FOR**mat **DA**Ta **LiNK**  
**SOUR**ce 1 **FAR** **EN**D **LOOp**  
**SOUR**ce 2 **PRO**tection

&gt;



## **15.6 ESF AND ESFz MODE OPERATION**

This section describes the controls, indicators, test results, alarms, and operating procedures that are affected by the addition of the ESF/SLC Option when operating in either the ESF or ESFz operating mode. The ZBTSI Option must be installed to test ESFz circuits (see Section 11, ZBTSI Framing Option). Unless otherwise indicated, the previous T-BERD 224 functions and capabilities still apply.

### **15.6.1 ESF and ESFz Mode Functional Description**

The T-BERD 224 can monitor and test the ESF and ESFz T1 signals and datalink by selecting either the T1-ESF or T1-ESFz mode and the appropriate channel format, i.e., VF, VF THRU, DS0, or DATLINK. Selecting either the VF, VF THRU, or DS0 channel format (see other sections for additional channel formats), enables the T-BERD 224 to test and analyze the T1 signal, report on the received datalink information, and regenerate the T1 signal and datalink information. Selecting the DATLINK channel format enables the T-BERD 224 to test the datalink itself and allow the T1 channels to be bypassed unaffected.

The ESF datalink information (4 kb/s (2 kb/s for ESFz) of the framing bits) includes the ANSI T1.403 Performance Report Message (PRM), priority messages (yellow alarm), and command and response messages (loopback and protection switching). The ESF/SLC Option enables the T-BERD 224 to report on and send out the PRMs on the datalink. If the BERT Option is installed, out-of-band datalink loop codes can be transmitted and responded to by the T-BERD 224 (see Section 13, BERT Option).

In normal T1 channel testing, the datalink information is analyzed and reported in the BPV & FRAME category, front panel display, and LOCAL STATUS LEDs. The BPV & FRAME category reports on the status of the PRM (see Section 15.7, ESF Performance Report Message Results). The LOCAL STATUS YELLOW ALARM LED reports on the detection of the yellow alarm. The **YELLOW ALARM ERROR INSERT** switch can send the yellow alarm. When the BERT Option is installed, datalink loop codes are transmitted when the **LOOP CODES** switches are pressed (see Section 13, BERT Option).

Connecting the T-BERD 224 across the span, as shown in Figure 15-4, illustrates how the T1 signal and datalink PRM flow through the T-BERD 224 when the AUX 20 PRM TX, PRM TRANS, function is set to

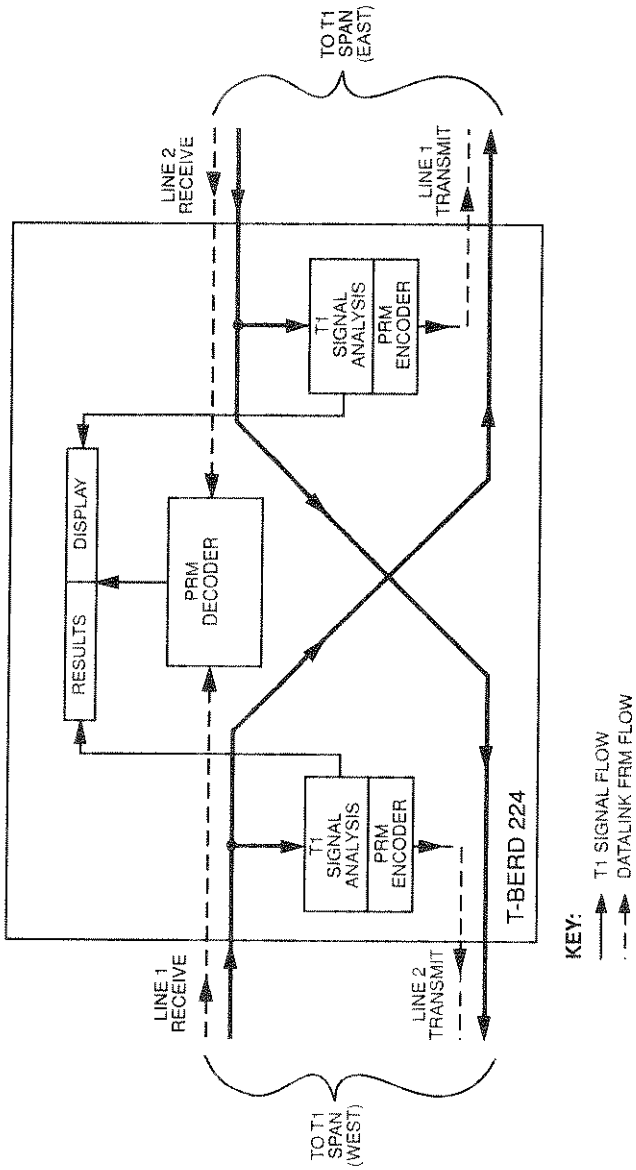

Figure 15-4  
T-BERD 224 T1 and Datalink PRM Signal Flow

---

---

## **SECTION 15**

AUTO. The received T1 signal on LINE 1 RECEIVE is analyzed and retransmitted on LINE 1 TRANSMIT. The T1 signal analysis is reported in the RESULTS display, and the PRM is encoded into the datalink and transmitted out on LINE 2 TRANSMIT. The received datalink PRM on LINE 1 RECEIVE is decoded and the results are displayed in the BPV & FRAME category results. Make note that the received PRM from LINE 1 RECEIVE is not the same PRM transmitted on LINE 2 TRANSMIT. This process is repeated on LINE 2 RECEIVE and LINE 1 TRANSMIT. When the AUX 20 PRM TX, PRM TRANS, is set to ON, the received PRM from the far end and the PRM generated by the T-BERD 224 are transmitted out to the far end. When PRM TRANS is set to OFF, the T-BERD 224 receives, but does not generate PRMs.

### **15.6.2 Controls and Indicators**

The following controls and indicators affect the operation of the T-BERD 224 when testing T1 ESF or ESFz circuits with the ESF/SLC Option installed. Refer to Table 15-1 for the switch configurations, selections, and Auxiliary functions added by the installation of the ESF/SLC Option. Unless otherwise indicated, the switch information described in Section 2, Instrument Description, also applies.

- **AUX** switch
- **MODE** switch
- **CHANNEL FORMAT** switch
- **YELLOW ALARM ERROR INSERT** switch
- **RESULTS I** switches
- **RESULTS II** switches

A typical T1 ESF or ESFz front panel display configuration might appear as follows:

|                   |         |                  |               |
|-------------------|---------|------------------|---------------|
| T1-ESF<br>FULL T1 | 3 IN 24 | 119-F BPV S<br>0 | RESULTS<br>OK |
|-------------------|---------|------------------|---------------|

|                          |                          |                          |                          |                          |                          |                          |                          |                          |                          |
|--------------------------|--------------------------|--------------------------|--------------------------|--------------------------|--------------------------|--------------------------|--------------------------|--------------------------|--------------------------|
| CHANNEL                  |                          | SCI                      |                          | SCII                     |                          | RESULTS I                |                          | RESULTS II               |                          |
| MODE                     | FORMAT                   |                          |                          |                          |                          |                          |                          |                          |                          |
| <input type="checkbox"/> | <input type="checkbox"/> | <input type="checkbox"/> | <input type="checkbox"/> | <input type="checkbox"/> | <input type="checkbox"/> | <input type="checkbox"/> | <input type="checkbox"/> | <input type="checkbox"/> | <input type="checkbox"/> |

To analyze the PRM results select either the T1-ESF or T1-ESFz mode, any channel format (except DATLINK), any source configuration, and the BPV & FRAME category (results n17 to n23). Each display and switch selection are described in the following sections.

#### AUX 20 PRM TX — ESF Datalink PRM Transmission Control

|                  |                        |                       |                   |
|------------------|------------------------|-----------------------|-------------------|
| AUX 20<br>PRM TX | L1 EMULATE<br>CUSTOMER | L2 EMULATE<br>CARRIER | PRM TRANS<br>AUTO |
|------------------|------------------------|-----------------------|-------------------|

|                          |                          |                          |                          |                          |                          |                          |                          |                          |                          |
|--------------------------|--------------------------|--------------------------|--------------------------|--------------------------|--------------------------|--------------------------|--------------------------|--------------------------|--------------------------|
| CHANNEL                  |                          | SCI                      |                          | SCII                     |                          | RESULTS I                |                          | RESULTS II               |                          |
| MODE                     | FORMAT                   |                          |                          |                          |                          |                          |                          |                          |                          |
| <input type="checkbox"/> | <input type="checkbox"/> | <input type="checkbox"/> | <input type="checkbox"/> | <input type="checkbox"/> | <input type="checkbox"/> | <input type="checkbox"/> | <input type="checkbox"/> | <input type="checkbox"/> | <input type="checkbox"/> |

Press the **AUX** switch to select the Auxiliary functions and press the **MODE** switch to select AUX 20 PRM TX (ESF Datalink PRM Transmission Control) function. The AUX 20 PRM TX function determines how the PRM is transmitted and emulated on both lines. The AUX function is only effective in the ESF and ESFz operating modes. The following switches configure the AUX function as follows:

**SCII** switch — Press the **SCII** switch to select the PRM emulation (L1 EMULATE) for LINE 1 as follows:

- **CUSTOMER** — The transmitted PRM emulates the customer-generated PRM. Selecting CUSTOMER sets the PRM C/R bit to 0. The customer PRM reports on the quality and performance of the received signal from the carrier. The customer PRM is

---

## SECTION 15

transmitted over the datalink to the carrier. **CUSTOMER** is the default setting. **L2 EMULATE** should be set to **CARRIER** for normal testing.

- **CARRIER** — The transmitted PRM emulates the carrier-generated PRM. Selecting **CARRIER** sets the PRM C/R bit to 1. The carrier PRM reports on the quality and performance of the received signal from the customer. The carrier PRM is transmitted over the datalink to the customer. **L2 EMULATE** should be set to **CUSTOMER** for normal testing.

**RESULTS I Category** switch — Press the **RESULTS I Category** switch to select the PRM emulation (**L2 EMULATE**) for **LINE 2** as previously described for **L1 EMULATE**. If **L2 EMULATE** is set for **CARRIER** emulation, then **L1 EMULATE** should be set to **CUSTOMER** for normal testing. If **L2 EMULATE** is set for **CUSTOMER** emulation, then **L1 EMULATE** should be set to **CARRIER** for normal testing.

**RESULTS II Results** switch — Press the **RESULTS II Results** switch to determine whether the PRM is transmitted. Select one of the following:

- **AUTO** — Enables the T-BERD 224 to determine automatically whether it should transmit PRM. In **AUTO**, the **LINE 1** and **LINE 2** datalinks are tested to determine which received datalink is active or inactive. An inactive datalink is defined as one that is idle, e.g., the line receiver is not connected to the circuit or a bit-oriented protocol (BOP) or message-oriented protocol (MOP) idle code is received. If the datalink is already active, no PRMs are generated for that line. If the datalink is inactive, the T-BERD 224 generates PRMs until activity is detected. The datalink is considered active if four consecutive non-idle BOP or MOP messages are received. When **AUTO** is selected, the line receivers are examined for 2 seconds to determine which line has an active datalink; PRMs are not generated during this period.
- **ON** — Enables the T-BERD 224 to transmit the PRM on both lines simultaneously. If line 1 and **LINE 2** are receiving data, the transmitted PRM on **LINE 1** is the PRM generated from the received data on **LINE 2**. Likewise, the transmitted PRM on **LINE 2** is the PRM generated from the received data on **LINE 1**.

- **OFF** — Disables the PRM transmission function. However, the received PRM is still reported in the BPV & FRAME category PRM results.

### **MODE Switch**

The ESF/SLC Option enables analysis of the T1-ESF and T1-ESFz datalink by selecting either the ESF or ESFz operating mode with the **MODE** switch. When using the T1-LLB mode, the received datalink PRM and T1 channels are retransmitted as they are received. However, when using the T1-TLB mode, the received datalink PRM is only reported in the BPV & FRAME category results and not retransmitted. The T-BERD 224 in turn analyzes the received T1 signal and generates the PRM on the received T1 signal, and transmits the PRM back to the source of the received signal.

### **CHANNEL FORMAT Switch**

The datalink results are available in all channel formats, with the exception of the DATLINK channel format. Selecting DATLINK enables the T-BERD 224 to insert on the datalink itself using any of the available source configurations. The datalink PRM results are reported in the BPV & FRAME category.

### **YELLOW ALARM ERROR INSERT Switch**

When the ESF or ESFz mode is selected, press the **YELLOW ALARM ERROR INSERT** switch to send the yellow alarm over the datalink. The yellow alarm is a priority message and overrides any messages already on the datalink.

## **15.7 ESF PERFORMANCE REPORT MESSAGE RESULTS**

The ESF datalink far-end Performance Report Message (PRM) results enable the T-BERD 224 to monitor and report on the status of the ESF Datalink Performance Report Message as described in the ANSI T1.403-1989 standard. Table 15-9 describes each of the datalink PRM test results.

---

---

## SECTION 15

The far-end PRM results include information on CRC error seconds, frame error seconds, severely-errored framing seconds, BPV errors, controlled slips, the number of received PRMs, and the originator of the PRM. The far-end PRM results are available when either the ESF or ESFz operating mode is selected. The far-end PRM results are available in all channel formats, except DATLINK. The PRM results are halted when frame or signal loss occurs during testing; pattern loss does not affect the results.

When a far-end PRM result count is an approximation because of a lost PRM, a "~" (tilde) precedes the result. When a result exceeds 99999, a ">" (greater than) sign precedes the result count indicating the result has overflowed. When the n22F CRC E result is displayed and the indicated count is an approximation of the actual CRC error count, a ">" (greater than) sign precedes the n22F CRC E result count. "UNAVAIL" appears in the far-end PRM results until either the ESF or ESFz mode is selected and the first PRM is received.

It should be noted that the following results apply to the received signal at the far end, not the received signal at the near end.

- n17F FR ES
- n18F F SES
- n19F BPV S
- n20F SLP S
- n22F CRC E
- n23PAY SRC

The n21PRM TIM result refers to the number of seconds that PRMs are received at the near end, not the far end.

**Table 15-9**  
**BPV & FRAME Category PRM Test Results**

| Result Name | Description                                                                                                                                                                                                                                                                                                        |
|-------------|--------------------------------------------------------------------------------------------------------------------------------------------------------------------------------------------------------------------------------------------------------------------------------------------------------------------|
| n17F FR ES  | Far-End Frame Error Seconds — A count of the seconds in which one or more frame errors occurred in the far end received signal. This result reports on the PRM Frame-Synchronization-Bit Error Event Bit (FE = 1) status.                                                                                          |
| n18F F SES  | Far-End Severely Errored Framing Seconds — A count of the seconds in which two or more frame errors occurred in less than 3 ms in the far end received signal. This result reports on the PRM Severely-Errored Framing Event Bit (SE = 1) status.                                                                  |
| n19F BPV S  | Far-End BPV Seconds — A count of the seconds in which one or more BPVs occurred in the far end received signal. This result reports on the PRM Line-Code Violation Event Bit (LV = 1) status.                                                                                                                      |
| n20F SLP S  | Far-End Controlled Slip Seconds — A count of the seconds in which controlled slips occurred in the far end received signal. This result reports on the PRM Controlled-Slip Event Bit (SL = 1) status. In addition, the T-BERD 224 transmits the PRM with the Controlled-Slip Event Bit (SL) set to 0.              |
| n21PRM TIM  | Received Performance Report Time — A count of the total number of seconds, since test restart, in which a valid PRM was received.                                                                                                                                                                                  |
| n22F CRC E  | Far-End CRC Errored Events — A count of the minimum number of CRC errors reported in the following n F SI CRC to n F SV CRC results. This result reports on the accumulated PRM CRC Error Event Bit (G1 to G6) results. A ">" (greater than) preceding the count indicates that the Bins 2 through 6 are non-zero. |
| n F SI CRC  | Far-End Single CRC Errored Seconds — A count of the seconds with only one CRC error reported in the far end received signal. This result reports on the first PRM CRC Error Event Bit (G1 = 1).                                                                                                                    |



**Table 15-9**  
**BPV & FRAME Category PRM Test Results (Continued)**

| Result Name | Description                                                                                                                                                                                                                                                                                                                                                                                                                                                                                                                                                                                                        |
|-------------|--------------------------------------------------------------------------------------------------------------------------------------------------------------------------------------------------------------------------------------------------------------------------------------------------------------------------------------------------------------------------------------------------------------------------------------------------------------------------------------------------------------------------------------------------------------------------------------------------------------------|
| n F LO CRC  | Far-End Low CRC Errored Seconds — A count of the seconds with 2 to 5 CRC errors reported in the far end received signal. This result reports on the second PRM CRC Error Event Bit (G2 = 1).                                                                                                                                                                                                                                                                                                                                                                                                                       |
| n F MD CRC  | Far-End Medium CRC Errored Seconds — A count of the seconds with 6 to 10 CRC errors reported in the far end received signal. This result reports on the third PRM CRC Error Event Bit (G3 = 1).                                                                                                                                                                                                                                                                                                                                                                                                                    |
| n F MH CRC  | Far-End Medium High CRC Errored Seconds — A count of the seconds with 10 to 100 CRC errors reported in the far end received signal. This result reports on the fourth PRM CRC Error Event Bit (G4 = 1).                                                                                                                                                                                                                                                                                                                                                                                                            |
| n F HI CRC  | Far-End High CRC Errored Seconds — A count of the seconds with 101 to 319 CRC errors reported in the far end received signal. This result reports on the fifth PRM CRC Error Event Bit (G5 = 1).                                                                                                                                                                                                                                                                                                                                                                                                                   |
| n F SV CRC  | Far-End Severe CRC Errored Seconds — A count of the seconds with 320 to 333 CRC errors reported in the far end received signal. This result reports on the sixth PRM CRC Error Event Bit (G6 = 1).                                                                                                                                                                                                                                                                                                                                                                                                                 |
| n23PAY SRC  | Far-End Payload Source/Loopback — Identifies the direction of the PRM according to the PRM Command/Response Bit (C/R) and the Payload Loopback Activated Bit (LB). In end-to-end applications, a customer generated PRM is indicated as CUST (C/R = 0 and LB = 0) and a carrier generated PRM is indicated as CARR (C/R = 1 and LB = 0) in the display. In payload loopback applications, the customer generated PRM is indicated as CUST LOOP (C/R = 0 and LB = 1) when the customer is looped back and the carrier generated PRM is indicated as CARR LOOP (C/R = 1 and LB = 1) when the carrier is looped back. |

## **15.8 TESTING T1 ESF CIRCUITS**

This procedure describes how the T-BERD 224 is connected to a DSX-1 patch panel to monitor and test a T1-ESF CSU datalink. Figure 15-5 illustrates how the T-BERD 224 is connected to the DSX-1 patch panel to test the CSU and allow the T1 channels to pass through unaffected. Table 15-10 configures the T-BERD 224 to monitor the datalink PRM and related test results.

**NOTE:** This is an in-service test procedure as long as the **INSERT** switch is set to **NONE**. This is an out-of-service test procedure for the selected channel and does not interfere with the normal operation of the other T1 channels.

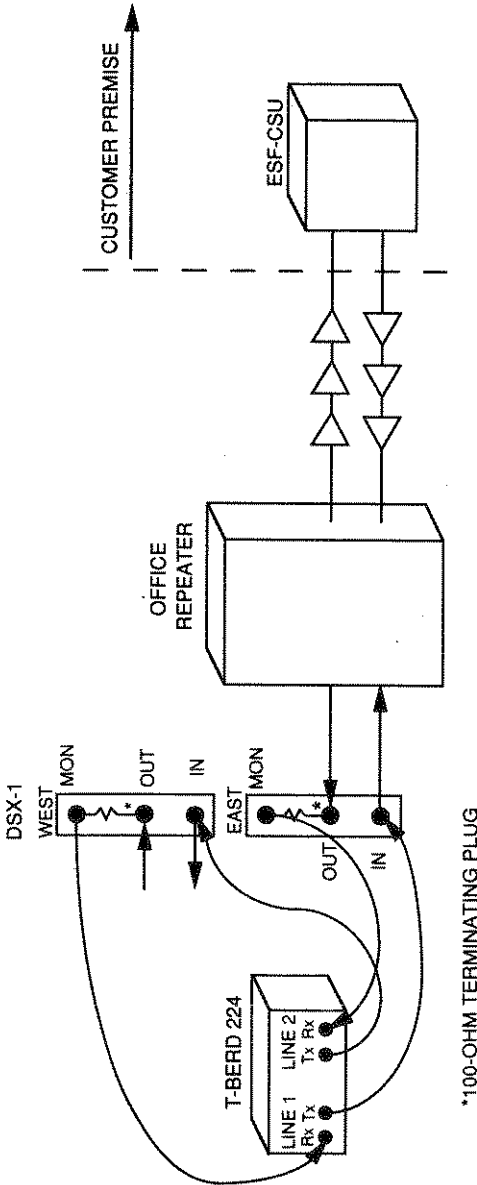

Figure 15-5  
Connections for Testing a T1-ESF CSU

**Table 15-10**  
**Test Set-Up for Testing an T1-ESF CSU**

| Step | Controls/Indicators/<br>Connections                                          | Activity                                                                                                                                                                                                                                                                                                                                                                                                                      |
|------|------------------------------------------------------------------------------|-------------------------------------------------------------------------------------------------------------------------------------------------------------------------------------------------------------------------------------------------------------------------------------------------------------------------------------------------------------------------------------------------------------------------------|
| 1.   | T1 Circuit Connections                                                       | <p>Perform the procedure in Section 4.2.1, T1 Circuit Monitoring, to connect the T-BERD 224 to the T1 circuit to monitor the SLC-96 datalink with the following switch settings:</p> <ul style="list-style-type: none"> <li>(a) <b>MODE</b> switch is set to T1-ESF.</li> <li>(b) <b>CHANNEL FORMAT</b> switch is set to FULL T1.</li> <li>(c) <b>SCI</b> and <b>SCII</b> switches are not required for this test.</li> </ul> |
| 2.   | <b>RESULTS I &amp; II</b> switches                                           | <ul style="list-style-type: none"> <li>(a) Display SUMMARY category in the RESULTS I display.</li> <li>(b) Display BPV &amp; FRAME category in the RESULTS II display.</li> </ul>                                                                                                                                                                                                                                             |
| 3.   | <b>DISPLAY HOLD, LOOP CODES, SIGNALING INSERT, and ERROR INSERT</b> switches | Verify that all switches are released (switch LEDs are extinguished).                                                                                                                                                                                                                                                                                                                                                         |
| 4.   | <b>VOLUME</b> switch                                                         | Ignore switch.                                                                                                                                                                                                                                                                                                                                                                                                                |
| 5.   | <b>TEST</b> switch                                                           | Set to CONT. or TIMED testing, as required.                                                                                                                                                                                                                                                                                                                                                                                   |
| 6.   | <b>CODE</b> switch                                                           | Set to AMI or B8ZS coding.                                                                                                                                                                                                                                                                                                                                                                                                    |
| 7.   | <b>AUX</b> switch                                                            | Select Auxiliary functions ( <b>AUX</b> switch LED is illuminated).                                                                                                                                                                                                                                                                                                                                                           |
| 8.   | <b>MODE</b> switch                                                           | Select AUX 20 PRM TX. Set L1 EMULATE to CARRIER, L2 EMULATE to CUSTOMER, and PRM TRANS to AUTO (see Section 15.6.2).                                                                                                                                                                                                                                                                                                          |
| 9.   | <b>AUX</b> switch                                                            | Release Auxiliary functions ( <b>AUX</b> switch LED is extinguished).                                                                                                                                                                                                                                                                                                                                                         |
| 10.  | <b>DROP</b> switch                                                           | Set to LINE 2 (LINE 2 LED illuminates). Monitor the received PRM from thew CSU (see Figure 15-5).                                                                                                                                                                                                                                                                                                                             |

**Table 15-10**  
**Test Set-Up for Testing an T1-ESF CSU (Continued)**

| Step       | Controls/Indicators/<br>Connections    | Activity                                                                                                                                                                                                                                                                                                                                                                                                                                                                                                                                                                                                                                                                                                        |            |            |            |            |            |            |            |            |            |            |            |            |            |  |
|------------|----------------------------------------|-----------------------------------------------------------------------------------------------------------------------------------------------------------------------------------------------------------------------------------------------------------------------------------------------------------------------------------------------------------------------------------------------------------------------------------------------------------------------------------------------------------------------------------------------------------------------------------------------------------------------------------------------------------------------------------------------------------------|------------|------------|------------|------------|------------|------------|------------|------------|------------|------------|------------|------------|------------|--|
| 11.        | INSERT switch                          | Set to NONE (NONE LED illuminates). This prevents live data on a selected channel from being interrupted.                                                                                                                                                                                                                                                                                                                                                                                                                                                                                                                                                                                                       |            |            |            |            |            |            |            |            |            |            |            |            |            |  |
| 12.        | SUMMARY RESULTS<br>Verification        | <p>Check the SUMMARY category for one or more of the following:</p> <p>(a) ALL RESULTS OK - No errors found, span operational.</p> <p>(b) Errored Results - non-zero or out-of-specification results reported on received signal:</p> <p>225 BPVS<br/>           BPV &amp; FRAME Category</p> <p>230 FRM ERR<br/>           BPV &amp; FRAME Category</p> <p>232 CRC ERR<br/>           BPV &amp; FRAME Category</p> <p>234 FRM LOS<br/>           BPV &amp; FRAME Category</p> <p>240 RX FREQ<br/>           SIGNAL Category</p> <p>251 TM SLIP<br/>           SIGNAL Category</p> <p>Further sectionalization is required on the received line. Further sectionalization is required on the transmit line.</p> |            |            |            |            |            |            |            |            |            |            |            |            |            |  |
| 13.        | BPV & FRAME<br>RESULTS<br>Verification | <p>Check the BPV &amp; FRAME category for the following PRM results. These results report on the status of the far-end received signal.</p> <table border="0"> <tr> <td>217F FR ES</td> <td>2 F LO CRC</td> </tr> <tr> <td>218F F SES</td> <td>2 F MD CRC</td> </tr> <tr> <td>219F BPV S</td> <td>2 F MH CRC</td> </tr> <tr> <td>220F SLP S</td> <td>2 F SI CRC</td> </tr> <tr> <td>221PRM TIM</td> <td>2 F SV CRC</td> </tr> <tr> <td>222F CRC E</td> <td>223PAY SRC</td> </tr> <tr> <td>2 F HI CRC</td> <td></td> </tr> </table>                                                                                                                                                                              | 217F FR ES | 2 F LO CRC | 218F F SES | 2 F MD CRC | 219F BPV S | 2 F MH CRC | 220F SLP S | 2 F SI CRC | 221PRM TIM | 2 F SV CRC | 222F CRC E | 223PAY SRC | 2 F HI CRC |  |
| 217F FR ES | 2 F LO CRC                             |                                                                                                                                                                                                                                                                                                                                                                                                                                                                                                                                                                                                                                                                                                                 |            |            |            |            |            |            |            |            |            |            |            |            |            |  |
| 218F F SES | 2 F MD CRC                             |                                                                                                                                                                                                                                                                                                                                                                                                                                                                                                                                                                                                                                                                                                                 |            |            |            |            |            |            |            |            |            |            |            |            |            |  |
| 219F BPV S | 2 F MH CRC                             |                                                                                                                                                                                                                                                                                                                                                                                                                                                                                                                                                                                                                                                                                                                 |            |            |            |            |            |            |            |            |            |            |            |            |            |  |
| 220F SLP S | 2 F SI CRC                             |                                                                                                                                                                                                                                                                                                                                                                                                                                                                                                                                                                                                                                                                                                                 |            |            |            |            |            |            |            |            |            |            |            |            |            |  |
| 221PRM TIM | 2 F SV CRC                             |                                                                                                                                                                                                                                                                                                                                                                                                                                                                                                                                                                                                                                                                                                                 |            |            |            |            |            |            |            |            |            |            |            |            |            |  |
| 222F CRC E | 223PAY SRC                             |                                                                                                                                                                                                                                                                                                                                                                                                                                                                                                                                                                                                                                                                                                                 |            |            |            |            |            |            |            |            |            |            |            |            |            |  |
| 2 F HI CRC |                                        |                                                                                                                                                                                                                                                                                                                                                                                                                                                                                                                                                                                                                                                                                                                 |            |            |            |            |            |            |            |            |            |            |            |            |            |  |

## 15.9 ESF MODE REMOTE CONTROL COMMANDS

Refer to Section 6, Remote Control Operation, for complete information on the setup and operation of the T-BERD 224 from a remote control device. This section identifies error messages and remote control commands that are added when the ESF/SLC Option is installed.

### 15.9.1 Remote Control Error Messages

Refer to Section 6.4, Error Messages, for additional error messages.

### 15.9.2 Remote Control Commands

Table 15-11 lists the available remote control commands that enable control of the ESF portion of the ESF/SLC Option from a remote device when testing ESF or ESFz datalinks. The remote control commands are described in the following sections. Refer to Section 6.5, Remote Control Commands, for the standard remote control commands.

**Table 15-11**  
**ESF and ESFz Datalink Remote Control Commands**

| Command          | Command Name                 |
|------------------|------------------------------|
| CHA FOR [ ]*     | Set Channel Format           |
| Ln PRM EMU [ ]   | Set Line PRM Emulation       |
| MOD [ ]*         | Transmit and Receive Mode    |
| PRI*             | Initiate Printout            |
| PRM TRA [ ]      | Set PRM Transmission Control |
| RES 1 and 2 [ ]* | Result Display Control       |

\* Available with the standard T-BERD 224.

---

---

**SECTION 15**

**CHA FOR**

**CHA FOR**

**Channel Format**

- CHA FOR?** :Displays the current channel format
- CHA FOR DAT LIN** :Enables access to the ESF(z) datalink channel when the ESF or ESFz mode is selected (see **MOD** command) to test the datalink

The **CHAnnel FORmat** parameter, **DATa LINK**, enables the T-BERD 224 to test the ESF or ESFz datalink by selecting a source from the **SOU 1** command. To analyze the datalink PRM, select any channel format, except **DATa LINK**. Refer to Section 6.5, Remote Control Commands, for additional **CHAnnel FORmat** commands to test the T1 signals. This command is identical to pressing the **CHANNEL FORMAT** switch.

**NOTE:** Changing the channel format causes a test restart and changes the current front panel configuration to the previous configuration of the selected channel format. A warning is printed indicating the new set up (see **EXAMPLE**).

See also: **Ln PRM EMU, MOD, PRI, PRM TRA, and RES 1/2**

**EXAMPLE:**

- > **CHA FOR?** :display the current channel format  
CHAnnel FORmat VF THRu
- > **CHA FOR DAT LIN** :select DATLINK as the channel format

**WARNING: New Setup:**

MODe T1 ESF  
CHAnnel FORmat DATa LINK  
SOUrce 1 3 IN 24  
SOUrce 2

>

**Ln PRM EMU****Ln PRM EMU****Set Line PRM Emulation**

**Ln PRM EMU?** :Displays current PRM emulation on the indicated line

**Ln PRM EMU CAR** :Selects the **CAR**rier PRM emulation on the indicated line (PRM C/R bit = 1)

**Ln PRM EMU CUS** :Selects the **CUS**tomer PRM emulation on the indicated line (PRM C/R bit = 0)

This command is identical to setting the line emulation with the AUX 20 PRM TX, L1/2 EMULATE, function.

See also: **CHA FOR, MOD, PRI, PRM TRA,** and **RES 1/2**

**EXAMPLE:**

**> L1 PRM EMU?** :display status of the PRM emulation on  
LINE 1

L1 PRM EMUlate CARRier

**> Ln PRM EMU CUS** :set line n PRM emulation to CUStomer

**>**



---

**SECTION 15**

**PRI** **PRI**

Initiate Printout

**PRI [result]n?** :Initiates a results printout for the indicated  
**[result] n** = LINE "1" or LINE "2"

**PRI CON** :Initiates a controls printout

**PRI RES** :Initiates a results printout

The **PRI [result]n?** command allows PRM results to be printed when the T1 ESF or ESFz mode is selected and frame synchronization is established. Replace **[result]n** with one of the following results:

- F BPV Sn** — Far-End BPV Seconds
- F CRC En** — Far-End CRC Errored Events
- F F SESn** — Far-End Severely Errored Framing Seconds
- F F ESn** — Far-End Frame Error Seconds
- F SLP Sn** — Far-End Controlled Slip Seconds
- HI CRCn** — Far-End High CRC Errored Seconds
- LO CRCn** — Far-End Low CRC Errored Seconds
- MD CRCn** — Far-End Medium CRC Errored Seconds
- MH CRCn** — Far-End Medium High CRC Errored Seconds
- PAY SRCn** — Far-End Payload Source/Loopback
- PRM TIMn** — Received Performance Report Time
- SI CRCn** — Far-End Single CRC Errored Seconds
- SV CRCn** — Far-End Severe CRC Errored Seconds

**UNAVAIL** appears as the result before the PRMs are received and either the ESF or ESFz mode is selected.

**N/A** appears as the result before establishing frame synchronization or command is not applicable to current configuration.

Refer to Section 6.5 Remote Control Commands, for additional **PRI** results.

See also: **CHA FOR, Ln PRM EMU, MOD, PRM TRA, and RES 1/2**

PRI

PRI

Initiate Printout (Continued)

EXAMPLE:

```
> PRI F F SES1? :print the far-end severely errored framing
 seconds result for LINE 1
 F F SES1 29394 :29394 far end severely errored framing sec-
 onds are detected on LINE 1
v
```

---

---

**SECTION 15****PRM TRA****PRM TRA****Set PRM Transmission Control**

|                    |                                                                                     |
|--------------------|-------------------------------------------------------------------------------------|
| <b>PRM TRA?</b>    | :Displays current setting of the PRM transmission control                           |
| <b>PRM TRA OFF</b> | :PRM transmission is disabled                                                       |
| <b>PRM TRA ON</b>  | :Enables the T-BERD 224 to transmit the PRM on both lines simultaneously            |
| <b>PRM TRA AUT</b> | :Enables the T-BERD 224 to automatically determine if the PRM is transmitted or not |

This command is identical to setting the PRM transmission capability with the AUX 20 PRM TX, PRM TRANS, function. Refer to Section 15.6.2, AUX 20 PRM TX — ESF Datalink PRM Transmission Control, for additional information.

See also: **CHA FOR**, **Ln PRM EMU**, **MOD**, **PRI**, and **RES 1/2**

**EXAMPLE:**

- > PRM TRA?** :display status of the PRM transmission control
- PRM TRANsmit OFF
- > PRM TRA AUT** :set PRM transmission control to AUTO
- >**

RES 1 and 2

RES 1 and 2

## Result Display Control

- RES [1|2]?** :Prints the displayed result in the Results I or II display
- RES 1 [result]n** :Display the indicated **[result]** in Results I display. **n** = LINE "1" or LINE "2"
- RES 2 [result]n** :Display the indicated **[result]** in Results II display

Unlike the **PRINT** command, the **RES** command calls up the specified results in the Results displays. The specified result is not displayed at the remote control unit, unless **RES [1|2]?** is used. Replace **[result]n** with one of the following results:

- F BPV Sn** — Far-End BPV Seconds
- F CRC En** — Far-End CRC Errored Events
- F F SESn** — Far-End Severely Errored Framing Seconds
- F F ESn** — Far-End Frame Error Seconds
- F SLP Sn** — Far-End Controlled Slip Seconds
- HI CRCn** — Far-End High CRC Errored Seconds
- LO CRCn** — Far-End Low CRC Errored Seconds
- MD CRCn** — Far-End Medium CRC Errored Seconds
- MH CRCn** — Far-End Medium High CRC Errored Seconds
- PAY SRCn** — Far-End Payload Source/Loopback
- PRM TIMn** — Received Performance Report Time
- SI CRCn** — Far-End Single CRC Errored Seconds
- SV CRCn** — Far-End Severe CRC Errored Seconds

**UNAVAIL** appears as the result before the PRMs are received and either the ESF or ESFz mode is selected.

**N/A** appears when the command is not applicable to current configuration.

Refer to Section 6.5, Remote Control Commands, for additional **RES** results.

See also: **CHA FOR**, **Ln PRM EMU**, **MOD**, **PRI**, and **PRM TRA**

---

---

**SECTION 15**

**RES 1 and 2**

**RES 1 and 2**

**Result Display Control (Continued)**

**EXAMPLE:**

> **RES 1 PRM TIM1** :display received performance report time  
result for LINE 1 (121PRM TIM) in the  
Results I display

> **RES 1?** :print the current result in the Results I display

PRM TIM1 3920349

>

**FACTORY DEFAULT SETTINGS**

This appendix contains the factory default settings that are stored in memory. The T-BERD 224's controls can be forced to their default settings by momentarily pressing the **RESTART** switch while the unit is being powered-up. As soon as the software revision message is visible in the display window, release the **RESTART** switch. Otherwise the unit will consider the **RESTART** switch to be stuck and will ignore it from that time on.

**Table A-1  
Factory Default Settings**

| <b>Parameter</b>       | <b>Default</b>          |
|------------------------|-------------------------|
| MODE                   | T1-D1D                  |
| CHANNEL FORMAT         | VF                      |
| SOURCE CONFIGURATION I | 1004 Hz                 |
| RESULTS I & II         | SUMMARY                 |
| DISPLAY HOLD           | OFF                     |
| SIGNALING INSERT       | OFF                     |
| ERROR INSERT           | OFF                     |
| CODE                   | AMI                     |
| TEST                   | CONT.                   |
| PRINT EVENT            | OFF                     |
| RECEIVE INPUT LINE 1   | BRIDGE                  |
| RECEIVE INPUT LINE 2   | BRIDGE                  |
| LINE 1                 | CHANNEL 1               |
| LINE 2                 | CHANNEL 1               |
| DROP                   | BOTH                    |
| INSERT                 | NONE                    |
| AUX 01 CL FIFO         | (N/A)                   |
| AUX 02 TIM PRI         | 6 HRS 00 MINS 00 SECS   |
| AUX 03 TES LEN         | 200 HRS 00 MINS 00 SECS |
| AUX 04 TIM/DAY         | (N/A)                   |
| AUX 05 LBO             | See the following:      |
| LINE 1                 | 0 dB                    |
| LINE 2                 | 0 dB                    |
| AUX 06 BACKTM          | INTERNAL                |
| AUX 07 DS0 TM          | COMMON                  |
| AUX 08 RS 232          | See the following:      |
| PARITY                 | NONE                    |

**Table A-1  
Factory Default Settings (Continued)**

| Parameter                    | Default            |
|------------------------------|--------------------|
| BAUD                         | 9600               |
| TERM                         | CR                 |
| AUX 09 488MODE <sup>1</sup>  | See the following: |
| ADDR:                        | 0                  |
| SRQ:                         | OFF                |
| AUX 10 N-CONTIG <sup>2</sup> | (NONE)             |
| AUX 11 ANL CHA <sup>2</sup>  | PRIMARY            |
| AUX 12 ERR COR <sup>2</sup>  | OFF                |
| AUX 13 ERR RT <sup>3</sup>   | See the following: |
| ERROR RATE                   | 1.0 E-3            |
| ERROR TYPE                   | SINGLE             |
| BURST LEN                    | 20 ms              |
| AUX 14 FRM ERR <sup>3</sup>  | SINGLE             |
| AUX 15 USER <sup>3</sup>     | 10000              |
| AUX 16 PGM LP <sup>3</sup>   | See the following: |
| UP:                          | 10000              |
| DOWN:                        | 100                |
| AUX 17 LOOP CD <sup>3</sup>  | See the following: |
| TYPE:                        | T1                 |
| EQUIP:                       | CSU                |
| AUX 18 AUT RES <sup>3</sup>  | NO RESP            |
| AUX 19 DDS CHN <sup>3</sup>  | See the following: |
| TRANSMIT                     | PRIMARY            |
| ANALYZE                      | PRIMARY            |
| AUX 20 PRM TX <sup>4</sup>   | See the following: |
| L1 EMULATE                   | CUSTOMER           |
| L2 EMULATE                   | CUSTOMER           |
| PRM TRANS                    | AUTO               |
| AUX 21 SWEEP <sup>5</sup>    | See the following: |
| START FREQ                   | 104 Hz             |
| STOP FREQ                    | 3704 Hz            |
| STEP-SIZE                    | 100 Hz             |
| STEP-INTERVAL                | 2.0 Seconds        |
| SKIP-HI                      | 2750 Hz            |
| SKIP-LO                      | 2450 Hz            |
| AUX 22 VFBURST <sup>5</sup>  | OFF                |
| AUX 23 PRT OPT <sup>5</sup>  | OFF                |

<sup>1</sup>Requires the IEEE-488 Option.

<sup>2</sup>Requires the DSU-DP Option.

<sup>3</sup>Requires the T1/Fractional T1/DDS BERT Option.

<sup>4</sup>Requires the Enhanced ESF/SLC Option.

<sup>5</sup>Requires the VF Option.

**CHANNEL TIME SLOT ASSIGNMENTS****B.1 OVERVIEW**

This appendix contains the T1 time slot assignments for the T1 framing formats supported by the T-BERD 224. Table B-1 lists the T1 time slot number and the corresponding channel numbering for the selected framing format.

**Table B-1**  
**Channel Time Slot Assignments**

| T1<br>Time<br>Slot | Channel Circuit Numbers |       |                            |
|--------------------|-------------------------|-------|----------------------------|
|                    | T1-D1D<br>T1-SLC96      | T1-D2 | T1-D4<br>T1-ESF<br>T1-ESFz |
| 1                  | 1                       | 12    | 1                          |
| 2                  | 13                      | 13    | 2                          |
| 3                  | 2                       | 1     | 3                          |
| 4                  | 14                      | 17    | 4                          |
| 5                  | 3                       | 5     | 5                          |
| 6                  | 15                      | 21    | 6                          |
| 7                  | 4                       | 9     | 7                          |
| 8                  | 16                      | 15    | 8                          |
| 9                  | 5                       | 3     | 9                          |
| 10                 | 17                      | 19    | 10                         |
| 11                 | 6                       | 7     | 11                         |
| 12                 | 18                      | 23    | 12                         |
| 13                 | 7                       | 11    | 13                         |
| 14                 | 19                      | 14    | 14                         |
| 15                 | 8                       | 2     | 15                         |
| 16                 | 20                      | 18    | 16                         |
| 17                 | 9                       | 6     | 17                         |
| 18                 | 21                      | 22    | 18                         |
| 19                 | 10                      | 10    | 19                         |
| 20                 | 22                      | 16    | 20                         |
| 21                 | 11                      | 4     | 21                         |
| 22                 | 23                      | 20    | 22                         |
| 23                 | 12                      | 8     | 23                         |
| 24                 | 24                      | 24    | 24                         |



---

---

## **APPENDIX B**

The T-BERD 224 contains a look-up table that translates a selected channel number to the correct time slot for the selected data format. For example, when MODE is set to T1-SLC96 and CHANNEL is set to 3, the T-BERD 224 isolates time slot 5 for monitoring and testing purposes.

## OPERATING MESSAGES

### C.1 OVERVIEW

This appendix contains a list of the operating messages that are flashed in the displays, along with an explanation of what caused the message to be displayed.

### C.2 DISPLAYED MESSAGES

Operating messages are displayed to provide a visual indication to help the operator. Some of these messages are displayed once and other messages are flashed until the cause of the condition is changed or corrected.

Table C-1 lists the T-BERD 224 Mainframe messages displayed and the reason for each display. Table C-2 lists the BERT Option operating messages displayed and the reason for each display. Table C-3 lists the VF Option operating messages displayed and the reason for each display. Table C-4 lists the Enhanced ESF/SLC Option operating messages displayed and the reason for each display. To help the operator, a suggestion is also included on what to do to correct, if necessary, the condition that caused the message to be displayed.

**Table C-1**  
**T-BERD 224 Mainframe Operating Messages**

| <b>Message Displayed</b> | <b>Cause and Suggested Correction</b>                                                                                                                                                                               |
|--------------------------|---------------------------------------------------------------------------------------------------------------------------------------------------------------------------------------------------------------------|
| UNDER REMOTE CONTROL     | Flashed when the unit is under remote control. This message alternates with the displayed results and operating status. This message is disabled by exiting the remote control mode and returning to local control. |

Table C-1  
T-BERD 224 Mainframe Operating Messages (Continued)

| Message Displayed                              | Cause and Suggested Correction                                                                                                                                                                                                                                                                                                                                  |
|------------------------------------------------|-----------------------------------------------------------------------------------------------------------------------------------------------------------------------------------------------------------------------------------------------------------------------------------------------------------------------------------------------------------------|
| TIMED TEST COMPLETE                            | This message is flashed alternating with the displayed results and operating status. This message is displayed when a timed test is finished. This message is disabled by setting the <b>TEST</b> switch to <b>CONT.</b> , or by pressing the <b>RESTART</b> switch to begin the test again.                                                                    |
| FIFO CLEARED                                   | This message is displayed when the <b>SCII</b> switch was pressed in response to the <b>AUX 01</b> question (CLEAR FIFO?).                                                                                                                                                                                                                                      |
| EXT CLOCK LOSS                                 | This message is displayed when <b>AUX 06</b> is set to <b>EXTERNAL</b> and no signal is detected at the side panel BNC connector. This message is cleared by setting <b>AUX 06</b> to <b>INTERNAL</b> or by connecting a T1 clock source to the BNC connector.                                                                                                  |
| USE RESULTS I/II TO EXIT TRAFFIC               | This message is displayed when a front panel switch ( <b>MODE</b> , <b>CHANNEL FORMAT</b> , <b>SCI</b> , or <b>SCII</b> ) is pressed while the traffic results (n55 or n56) is still visible in the display. This message is disabled by pressing the same <b>RESULTS I</b> or <b>II</b> switch to display another result or select another category.           |
| UNEQUAL # OF CHANNELS, CONFIGURATION NOT SAVED | This message is displayed when an unequal number of channels is entered for <b>AUX 10 N-CONTG</b> . Redisplaying the channel numbers for <b>AUX 10 N-CONTG</b> shows the last valid channels that were selected. To prevent this message from being displayed, enter the same number of channels for <b>LINE 1</b> as are entered for <b>LINE 2</b> .           |
| SEE AUX 10 TO SET CHNL NUMBERS                 | This message is displayed once when noncontiguous is selected by the <b>SCII</b> switch. Use <b>AUX 10 N-CONTG</b> to set the non-contiguous channels for <b>LINE 1</b> and <b>LINE 2</b> .                                                                                                                                                                     |
| SEE AUX 03 TO SET TEST LENGTH                  | This message is displayed once when the <b>TEST</b> switch is set to the <b>TIMED</b> position. This just reminds the operator that a time period must be set for the test length. <b>AUX 03 TES LEN</b> is used to set the test length. If no new length is selected, the last valid time length entered for <b>AUX 03 TES LEN</b> is the default test length. |

**Table C-1**  
**T-BERD 224 Mainframe Operating Messages (Continued)**

| Message Displayed                                    | Cause and Suggested Correction                                                                                                                                                                                                                                                                                                                                     |
|------------------------------------------------------|--------------------------------------------------------------------------------------------------------------------------------------------------------------------------------------------------------------------------------------------------------------------------------------------------------------------------------------------------------------------|
| SEE AUX 02 TO SET<br>PRI EVENT TIME                  | This message is displayed once when the <b>PRINT EVENT</b> switch is set to the <b>TIMED</b> position. This just reminds the operator that a time period must be set for the "print event". AUX 02 TIM PRI is used to set the timed print length. If no new length is selected, the last valid time length entered for AUX 02 TIM PRI is the default print length. |
| OPTION NOT<br>INSTALLED                              | This message is displayed once when an option, which is not currently installed, is required for a switch ( <b>LOOP CODES</b> or <b>LOGIC</b> ) to operate properly.                                                                                                                                                                                               |
| FRAMING PATTERN<br>UNKNOWN                           | This message is displayed once when the <b>MODE</b> switch is set to <b>AUTO</b> and an unframed pattern or a severely errored signal is attached to the <b>RECEIVE</b> input and frame sync cannot be achieved.                                                                                                                                                   |
| NO SUBRATE<br>FRAME SYNCLINE 1/<br>LINE 2/BOTH LINES | DS0B framing sync cannot be achieved for <b>LINE 1</b> , <b>LINE 2</b> , or <b>BOTH LINES</b> (three separate messages). Synchronization must be achieved before being able to insert data on a subrate channel. Applicable only when <b>CHANNEL FORMAT</b> switch is set to a DS0B subrate.                                                                       |
| NO BYTE<br>ALIGNMENT<br>LINE 1/LINE 2/<br>BOTH LINES | DS0A byte alignment cannot be achieved for <b>LINE 1</b> , <b>LINE 2</b> , or <b>BOTH LINES</b> (three separate messages). Applicable only when <b>AUX 12 ERR COR</b> is set to <b>ON</b> and <b>CHANNEL FORMAT</b> switch is set to <b>DS0A 2.4</b> , <b>DS0A 4.8</b> , or <b>DS0A 9.6</b> .                                                                      |
| NO SELECTION<br>AVAILABLE                            | This message is displayed once when a switch is pressed that has no selection for the present operating set-up. This message indicates that the switch is functioning but has no function for the current set-up.                                                                                                                                                  |
| ONLY SELECTION<br>AVAILABLE                          | This message is displayed once when a switch is pressed that has no other selection available for the present operating setup.                                                                                                                                                                                                                                     |
| COMMAND PORT<br>FAILURE                              | This message is displayed once when communication between internal microprocessors is lost. If error messages are observed, record them to help determine if repair is necessary.                                                                                                                                                                                  |

**Table C-2  
BERT Option Operating Messages**

| <b>Message Displayed</b>            | <b>Cause and Suggested Correction</b>                                                                                                                                                                                                                              |
|-------------------------------------|--------------------------------------------------------------------------------------------------------------------------------------------------------------------------------------------------------------------------------------------------------------------|
| ALT LOOP DOWN COMPLETE              | This message is displayed when the T-BERD 224 is no longer receiving a DDS alternating loop-down code after the <b>LOOP DOWN</b> switch is pressed.                                                                                                                |
| ALT LOOP UP COMPLETE                | This message is displayed when the T-BERD 224 is receiving a DDS alternating loop-up code after the <b>LOOP UP</b> switch is pressed.                                                                                                                              |
| ALT LOOP UP FAILED                  | This message is displayed when the T-BERD 224 is not synchronized to the DDS alternating loop-up code pattern after the <b>LOOP UP</b> switch is pressed.                                                                                                          |
| ESF PAYLOAD LOOP CODE SENT          | This message is displayed when the T-BERD 224 is sending an ESF payload loop code when either the <b>LOOP UP</b> or <b>LOOP DOWN</b> switch is pressed. Verify loopback by checking for pattern synchronization or sending bit errors.                             |
| LAT LOOP COMPLETE MAP0 LINE SIDE    | This message is displayed when the T-BERD 224 is receiving a DDS DS0-DP latching loop code confirmation message from the selected DS0-DP location after the <b>LOOP UP</b> switch is pressed. MAP0 LINE SIDE indicates that the Line side of the DS0-DP is looped. |
| LAT LOOP COMPLETE MAP1224 DROP SIDE | This message is displayed when the T-BERD is receiving a DDS DS0-DP latching loop code confirmation message from the selected DS0-DP location after the <b>LOOP UP</b> switch is pressed. MAP1 DROP SIDE indicates that the Drop side of the DS0-DP is looped.     |
| LAT LOOP DOWN COMPLETE              | This message is displayed when the T-BERD 224 is receiving a DDS latching loop-down code after the <b>LOOP DOWN</b> switch is pressed.                                                                                                                             |
| LAT LOOP UP COMPLETE/CONFIRMED      | This message is displayed when the T-BERD 224 is receiving a confirmed DDS latching loop-up code (Far-end voice code detected) after the <b>LOOP UP</b> switch is pressed.                                                                                         |

**Table C-2**  
**BERT Option Operating Messages (Continued)**

| Message Displayed                        | Cause and Suggested Correction                                                                                                                                                                                                                                                                                                                                    |
|------------------------------------------|-------------------------------------------------------------------------------------------------------------------------------------------------------------------------------------------------------------------------------------------------------------------------------------------------------------------------------------------------------------------|
| LAT LP UP<br>COMPLETE/NOT<br>CONFIRMED   | This message is displayed when the T-BERD 224 is receiving an unconfirmed DDS latching loop-up code (Far-end voice code not detected) after the <b>LOOP UP</b> switch is pressed. Check loopback by verifying pattern synchronization or sending bit errors. If response is positive, then the loopback is established.                                           |
| LOOP DOWN ABORTED                        | This message is displayed when either the transmitted T1 loop-down code is interrupted by pressing the <b>LOOP DOWN</b> switch (switch LED is illuminated). This message is also displayed when not receiving the T1 in-band loop-down response after a 30-second timeout and when not receiving the ESF out-of-band loop-down response after a 3-second timeout. |
| LOOP DOWN<br>SUCCESSFUL                  | This message is displayed when the in-band loop-down response is briefly detected or the out-of-band loop-down response is not detected for 1 second.                                                                                                                                                                                                             |
| LOOP UP ABORTED                          | This message is displayed when either the transmitted T1 loop-up code is interrupted by pressing the <b>LOOP UP</b> switch (switch LED is illuminated). This message is also displayed when not receiving the T1 in-band loop-up response after a 30-second timeout and when not receiving the ESF out-of-band loop-up response after a 3-second timeout.         |
| LOOP UP SUCCESSFUL                       | This message is displayed when the in-band loop-up response is briefly detected or the out-of-band loop-up response is not detected for 1 second.                                                                                                                                                                                                                 |
| Lx SLC DL ALARM                          | This message is displayed to indicate SLC datalink alarms are detected and reported in the SUMMARY category. Lx = LINE 1 or LINE 2.                                                                                                                                                                                                                               |
| OUT-OF-BAND CODES<br>REQUIRE ESF or ESFz | This message is displayed when an ESF out-of-band loop code is sent and the T1-ESF or                                                                                                                                                                                                                                                                             |

**Table C-2**  
**BERT Option Operating Messages (Continued)**

| Message Displayed              | Cause and Suggested Correction                                                                                                                                                                                                                                                                                                 |
|--------------------------------|--------------------------------------------------------------------------------------------------------------------------------------------------------------------------------------------------------------------------------------------------------------------------------------------------------------------------------|
| SEE AUX 17 TO SET LOOP CD TYPE | T1-ESFz mode is not selected. Correct the condition by either changing the AUX 17 LOOP CD, EQUIP, function to another equipment loop code other than ESF-LIN, ESF-PAY, or ESF-NET, or changing the operating mode to T1-ESF or T1-ESFz.                                                                                        |
| SEE AUX 19 TO SET SEC PATTERN  | This message is displayed as a reminder that the loop code type (T1, DDS-LAT, or DDS-ALT) is set by the AUX 17 LOOP CD function. The message appears when the <b>LOOP CODES</b> switches are pressed to send a loop code signal. If no type is selected, the last valid type entered for AUX 17 is the default LOOP CODE TYPE. |
|                                | This message is displayed as a reminder that the DDS secondary channel test pattern is selected from the AUX 19 DDS CHN function. The message appears when the operating mode and test pattern are displayed and the <b>SCI</b> switch is pressed in an attempt to change the test pattern.                                    |

**Table C-3**  
**VF Option Operating Messages**

| Message Displayed     | Cause and Suggested Correction                                                                                                                                                                                                                                                                                                                                                                            |
|-----------------------|-----------------------------------------------------------------------------------------------------------------------------------------------------------------------------------------------------------------------------------------------------------------------------------------------------------------------------------------------------------------------------------------------------------|
| LOSS OF HOLDING TONE  | This message is displayed during C-NCH noise, 3K NCH noise, or S/N testing. This message informs the operator that the expected holding tone that is filtered out in the notch range of 995 Hz to 1025 Hz (1004 Hz tone) is not detected. The operator should check the received signal VFFREQ (995 Hz to 1025 Hz) and VF LVL (greater than -40.0 dBm) are in the required ranges for valid test results. |
| RX LEVEL OUT OF RANGE | This message is displayed during a P/AR test if the signal level is outside of the range of 0.0 dBm                                                                                                                                                                                                                                                                                                       |

**Table C-3**  
**VF Option Operating Messages (Continued)**

| Message Displayed               | Cause and Suggested Correction                                                                                                                                                                                                                                                                                                                                                                                                                                                                                                          |
|---------------------------------|-----------------------------------------------------------------------------------------------------------------------------------------------------------------------------------------------------------------------------------------------------------------------------------------------------------------------------------------------------------------------------------------------------------------------------------------------------------------------------------------------------------------------------------------|
| SEE AUX 21 TO SET SWEEP PARAMS. | <p>to - received P/AR 40.0 dBm. The operator should adjust the PAR LEVEL to bring the signal level within this range.</p> <p>This message is displayed once when the <b>SCI</b> switch is set to the SWEEP position. This just reminds the operator that the frequency sweep parameters of START FREQ, STOP FREQ, STEP-SIZE, STEP-INTVL, SKIP-HI, and SKIP-LO are set in AUX 21 SWEEP. If the operator proceeds with the test without going to AUX 21 SWEEP, the last valid sweep parameters entered for AUX 21 SWEEP will be used.</p> |
| SEE AUX 22 TO SET BURST PARAMS  | <p>This message is displayed once when the <b>SCI</b> switch is set to any of the return loss measurements; ERL, SRL-LO, or SRL-HI. This just reminds the operator that the frequency burst parameters of ON/OFF, FREQ, and LEVEL are set in AUX 22 VFBURST. If the operator proceeds with the test without going to AUX 22 VFBURST, the last valid parameters entered for AUX 22 VFBURST will be used.</p>                                                                                                                             |
| SKIP HIGH SMALLER THAN SKIP LOW | <p>This message is displayed after the AUX 21 SWEEP parameters have been set and the operator attempted to exit the auxiliary function. This message informs the operator that the frequency sweep parameter of SKIP-HI is smaller than the SKIP-LO parameter. The T-BERD 224 automatically aborts all the parameters changes and restores the last valid parameters. The operator must return and repeat the entire AUX 21 SWEEP parameters settings procedure.</p>                                                                    |
| SKIP RANGE TOO BIG              | <p>This message is displayed after the AUX 21 SWEEP parameters have been set and the operator attempted to exit the auxiliary function. This message informs the operator that the frequency sweep parameters of SKIP-HI and SKIP-LO are too far apart and interfere with either the STEP-SIZE or the START FREQ and STOP FREQ range. The</p>                                                                                                                                                                                           |



**Table C-3**  
**VF Option Operating Messages (Continued)**

| Message Displayed                                  | Cause and Suggested Correction                                                                                                                                                                                                                                                                                                                                                                                                                                                                                                                                                                                                                                                                                    |
|----------------------------------------------------|-------------------------------------------------------------------------------------------------------------------------------------------------------------------------------------------------------------------------------------------------------------------------------------------------------------------------------------------------------------------------------------------------------------------------------------------------------------------------------------------------------------------------------------------------------------------------------------------------------------------------------------------------------------------------------------------------------------------|
| <p>STEP SIZE TOO LARGE DOESN'T MATCH ENDPOINTS</p> | <p>T-BERD 224 automatically aborts all the parameters changes and restores the last valid parameters. The operator must return and repeat the entire AUX 21 SWEEP parameters settings procedure.</p> <p>This message is displayed after the AUX 21 SWEEP parameters have been set and the operator attempted to exit the auxiliary function. This message informs the operator that the frequency sweep parameters of START FREQ and STOP FREQ allow too small a frequency band for the selected STEP-SIZE. The T-BERD 224 automatically aborts all the parameters changes and restores the last valid parameters. The operator must return and repeat the entire AUX 21 SWEEP parameters settings procedure.</p> |
| <p>VF OPTION FAILED</p>                            | <p>This message is displayed if the VF Option is not functioning and the operator attempts a test that requires the VF Option. This message is also displayed if the VF Option is not operating correctly during a T-BERD 224 Self Test. The operator should call TTC Customer Assistance.</p>                                                                                                                                                                                                                                                                                                                                                                                                                    |

**Table C-4**  
**Enhanced ESF/SLC Option Operating Messages**

| Message Displayed      | Cause and Suggested Correction                                                                                                                                                                                                                                                                       |
|------------------------|------------------------------------------------------------------------------------------------------------------------------------------------------------------------------------------------------------------------------------------------------------------------------------------------------|
| <p>Ln SLC DL ALARM</p> | <p>This message is displayed when the T-BERD 224 is in T1-ESF or T1-ESFz mode with SLC-96 source configuration, is monitoring the T1 circuit, and detects a SLC-96 datalink alarm. This message informs the operator that the alarm was detected and requires no further action by the operator.</p> |

**MINIMUM/MAXIMUM STRESS PATTERN**

A hexadecimal-to-binary conversion table appears below. On the next page is the optional MIN/MAX stress pattern. It is also the long user pattern default.

**Hexadecimal-to-Binary Conversion**

| H | 8421 |
|---|------|
| 0 | 0000 |
| 1 | 0001 |
| 2 | 0010 |
| 3 | 0011 |
| 4 | 0100 |
| 5 | 0101 |
| 6 | 0110 |
| 7 | 0111 |
| 8 | 1000 |
| 9 | 1001 |
| A | 1010 |
| B | 1011 |
| C | 1100 |
| D | 1101 |
| E | 1110 |
| F | 1111 |

MSB                      LSB  
74H = 0111 0100

APPENDIX D

Min/Max Stress Pattern

|                        |                        |                        |                        |                        |                        |                        |                        |                        |                        |
|------------------------|------------------------|------------------------|------------------------|------------------------|------------------------|------------------------|------------------------|------------------------|------------------------|
| 01<br>80H<br>1000 0000 | 02<br>80H<br>1000 0000 | 03<br>80H<br>1000 0000 | 04<br>80H<br>1000 0000 | 05<br>01H<br>0000 0001 | 06<br>00H<br>0000 0000 | 07<br>01H<br>0000 0001 | 08<br>01H<br>0000 0001 | 09<br>01H<br>0000 0001 | 10<br>03H<br>0000 0011 |
| 11<br>80H<br>1000 0000 | 12<br>01H<br>0000 0001 | 13<br>80H<br>1000 0000 | 14<br>01H<br>0000 0001 | 15<br>01H<br>0000 0001 | 16<br>80H<br>1000 0000 | 17<br>01H<br>0000 0001 | 18<br>22H<br>0010 0010 | 19<br>00H<br>0000 0000 | 20<br>20H<br>0010 0000 |
| 21<br>22H<br>0010 0010 | 22<br>00H<br>0000 0000 | 23<br>20H<br>0010 0000 | 24<br>AAH<br>1010 1010 | 25<br>AAH<br>1010 1010 | 26<br>AAH<br>1010 1010 | 27<br>AAH<br>1010 1010 | 28<br>AAH<br>1010 1010 | 29<br>55H<br>0101 0101 | 30<br>55H<br>0101 0101 |
| 31<br>55H<br>0101 0101 | 32<br>55H<br>0101 0101 | 33<br>AAH<br>1010 1010 | 34<br>AAH<br>1010 1010 | 35<br>AAH<br>1010 1010 | 36<br>AAH<br>1010 1010 | 37<br>55H<br>0101 0101 | 38<br>AAH<br>1010 1010 | 39<br>AAH<br>1010 1010 | 40<br>55H<br>0101 0101 |
| 41<br>55H<br>0101 0101 | 42<br>55H<br>0101 0101 | 43<br>80H<br>1000 0000 | 44<br>80H<br>1000 0000 | 45<br>FFH<br>1111 1111 | 46<br>FFH<br>1111 1111 | 47<br>FFH<br>1111 1111 | 48<br>FFH<br>1111 1111 | 49<br>FFH<br>1111 1111 | 50<br>FFH<br>1111 1111 |
| 51<br>FFH<br>1111 1111 | 52<br>FEH<br>1111 1111 | 53<br>FFH<br>1111 1111 | 54<br>FFH<br>1111 1111 | 55<br>24H<br>0010 0100 | 56<br>49H<br>0100 1001 | 57<br>92H<br>1001 0010 | 58<br>88H<br>1000 1000 | 59<br>88H<br>1000 1000 | 60<br>88H<br>1000 1000 |
| 61<br>10H<br>0001 0000 | 62<br>42H<br>0100 0010 | 63<br>08H<br>0000 1000 | 64<br>21H<br>0010 0001 | 65<br>84H<br>1000 0100 | 66<br>20H<br>0010 0000 | 67<br>08H<br>0000 1000 | 68<br>82H<br>1000 0010 | 69<br>40H<br>0100 0000 | 70<br>20H<br>0010 0000 |
| 71<br>10H<br>0001 0000 | 72<br>80H<br>1000 0000 | 73<br>--               | --                     | --                     | --                     | --                     | --                     | --                     | --                     |

## **SWITCH CONFIGURATIONS AND AUX FUNCTIONS**

This appendix lists the switch configurations and Auxiliary functions for a fully optioned T-BERD 224 by operating mode, channel format, and source configuration. Table E-1 lists the switch configurations and Auxiliary functions that apply to the T1-D1D, T1-D2, or T1-D4 mode. Table E-2 lists the switch configurations and Auxiliary functions that apply to the T1SLC96 mode. Table E-3 lists the switch configurations and Auxiliary functions that apply to the T1-ESF or T1-ESFz mode. Table E-4 lists the switch configurations and Auxiliary functions that apply to the T1 mode. Table E-5 indicates the relationship between the available loopback modes (AUTO LLB, T1 LLB, T1 TLB, AUTO PLB, and FT1 LLB) and operating modes (T1, T1-D1D, T1-D2, T1-D4, T1-ESF, T1-ESFz, and T1SLC96). A reference to the previous tables indicates the available switch configurations when the loopback mode synchronizes to the received signal.

Table E-1  
T1-D1D, T1-D2, or T1-D4 Mode Switch Configurations and AUX Functions

| Switches and AUX Functions              |                                                                                                                                                   | Configurations                                                                      |                                                                                                                                                                                                                              |                                                                                                                                                                                                                              |                                                                                                                                                                                                                  |
|-----------------------------------------|---------------------------------------------------------------------------------------------------------------------------------------------------|-------------------------------------------------------------------------------------|------------------------------------------------------------------------------------------------------------------------------------------------------------------------------------------------------------------------------|------------------------------------------------------------------------------------------------------------------------------------------------------------------------------------------------------------------------------|------------------------------------------------------------------------------------------------------------------------------------------------------------------------------------------------------------------|
|                                         |                                                                                                                                                   | T1-D1D, T1-D2, or T1-D4                                                             |                                                                                                                                                                                                                              |                                                                                                                                                                                                                              |                                                                                                                                                                                                                  |
| <b>MODE SWITCH</b>                      |                                                                                                                                                   |                                                                                     |                                                                                                                                                                                                                              |                                                                                                                                                                                                                              |                                                                                                                                                                                                                  |
| <b>CHANNEL FORMAT Switch</b>            | VF THRU<br>VF THRU                                                                                                                                | DS0A2.4 1/2<br>DS0A4.8 1/2<br>DS0A9.6 1/2<br>DS019.2 1/2<br>DS0A56 1/2<br>DS064 1/2 | DS0B2.4 1/2<br>DS0B4.8 1/2<br>DS0B9.6 1/2                                                                                                                                                                                    | 56 x N 1,3,2,3<br>64 x N 1,3,2,3                                                                                                                                                                                             | FULL T1 2                                                                                                                                                                                                        |
| <b>SOURCE CONFIGURATION Switch (SC)</b> | 1004 Hz<br>VF INTF<br>DROP CHAN<br>QUIET 4<br>FREQ 4<br>ERL 4<br>SRL-HI 4<br>SRL-LO 4<br>LEVEL 4<br>SWEEP 4<br>PAR 4<br>3 TONE SLP 4<br>2713 Hz 4 | BYTE<br>DS0 INTF<br>DROP CHAN                                                       | DSU-DP 1<br>ALL ONES 2<br>ALL ZERO 2<br>USER 2<br>MIN/MAX 2<br>2*23-1 2<br>2*20-1 2<br>2*15-1 2<br>2*15-1 INV 2<br>ORSS 2<br>3 IN 24 2<br>1.7 2<br>63 2<br>511 2<br>2047 2<br>DDS1 2<br>DDS2 2<br>DDS3 2<br>DDS4 2<br>AUTO 2 | DSU-DP 1<br>ALL ONES 2<br>ALL ZERO 2<br>USER 2<br>MIN/MAX 2<br>2*23-1 2<br>2*20-1 2<br>2*15-1 2<br>2*15-1 INV 2<br>ORSS 2<br>3 IN 24 2<br>1.7 2<br>63 2<br>511 2<br>2047 2<br>DDS1 2<br>DDS2 2<br>DDS3 2<br>DDS4 2<br>AUTO 2 | ALL ONES 2<br>ALL ZERO 2<br>USER 2<br>MIN/MAX 2<br>2*23-1 2<br>2*20-1 2<br>2*15-1 2<br>2*15-1 INV 2<br>ORSS 2<br>3 IN 24 2<br>1.7 2<br>63 2<br>511 2<br>2047 2<br>DDS1 2<br>DDS2 2<br>DDS3 2<br>DDS4 2<br>AUTO 2 |

Table E-1  
T1-D1D, T1-D2, or T1-D4 Mode Switch Configurations and AUX Functions (Continued)

| Switches and AUX Functions    | Configurations                                                                                                                                                                             |                         |                 |                                                                                       |                                                       |
|-------------------------------|--------------------------------------------------------------------------------------------------------------------------------------------------------------------------------------------|-------------------------|-----------------|---------------------------------------------------------------------------------------|-------------------------------------------------------|
|                               | 20 - 3904 Hz <sup>5</sup><br>-40.0 - +3.0 dBm <sup>6</sup><br>-10.0 - -40.0 dBm <sup>7</sup><br>404 Hz <sup>8</sup><br>1004 Hz <sup>8</sup><br>2804 Hz <sup>8</sup><br>OFF/ON <sup>9</sup> | XXXX XXXX <sup>10</sup> |                 | CHAN 1 - 20 <sup>1/2</sup><br>CHAN 1 - 10 <sup>1/2</sup><br>CHAN 1 - 5 <sup>1/2</sup> | N = 1 - 24 <sup>12</sup><br>NON CONTIG <sup>1/2</sup> |
| AUX_01 CL FIFO                | X                                                                                                                                                                                          | X                       | X               | X                                                                                     | X                                                     |
| AUX_02 TIM PRI                | X                                                                                                                                                                                          | X                       | X               | X                                                                                     | X                                                     |
| AUX_03 TES LEN                | X                                                                                                                                                                                          | X                       | X               | X                                                                                     | X                                                     |
| AUX_04 TIM/DAY                | X                                                                                                                                                                                          | X                       | X               | X                                                                                     | X                                                     |
| AUX_05 LBO                    | X                                                                                                                                                                                          | X                       | X               | X                                                                                     | X                                                     |
| AUX_06 BACK TM                | X                                                                                                                                                                                          | X                       | X               | X                                                                                     | X                                                     |
| AUX_07 DS0 TM                 | X                                                                                                                                                                                          | X                       | X               | X                                                                                     | X                                                     |
| AUX_08 RS_232                 | X                                                                                                                                                                                          | X                       | X               | X                                                                                     | X                                                     |
| AUX_09 488MODE <sup>11</sup>  | X                                                                                                                                                                                          | X                       | X               | X                                                                                     | X                                                     |
| AUX_10 N-CONTG <sup>1/2</sup> |                                                                                                                                                                                            |                         |                 |                                                                                       | X <sup>12</sup>                                       |
| AUX_11 ANL CHA <sup>1</sup>   |                                                                                                                                                                                            |                         | X <sup>13</sup> | X <sup>13</sup>                                                                       |                                                       |
| AUX_12 ERR COR <sup>1/2</sup> |                                                                                                                                                                                            |                         | X               | X                                                                                     |                                                       |
| AUX_13 ERR RT <sup>2</sup>    | X <sup>14</sup>                                                                                                                                                                            | X <sup>14</sup>         | X <sup>15</sup> | X <sup>15</sup>                                                                       | X <sup>15</sup>                                       |
| AUX_14 FRM ERR <sup>2</sup>   | X                                                                                                                                                                                          | X                       | X               | X                                                                                     | X                                                     |
| AUX_15 USER <sup>2</sup>      |                                                                                                                                                                                            |                         | X               | X                                                                                     | X                                                     |
| AUX_16 PGM LP <sup>2</sup>    |                                                                                                                                                                                            |                         | X               | X                                                                                     | X                                                     |
| AUX_17 LOOP CD <sup>2</sup>   |                                                                                                                                                                                            |                         | X               | X                                                                                     | X                                                     |
| AUX_18 AUTO RES <sup>2</sup>  |                                                                                                                                                                                            |                         | X               | X                                                                                     | X                                                     |
| AUX_19 DDS CHN <sup>2</sup>   |                                                                                                                                                                                            |                         | X               | X                                                                                     | X                                                     |
| AUX_20 PRM TX <sup>17</sup>   |                                                                                                                                                                                            |                         | X <sup>16</sup> | X <sup>16</sup>                                                                       | X                                                     |

Table E-1  
T1-D1D, T1-D2, or T1-D4 Mode Switch Configurations and AUX Functions (Continued)

| Switches and AUX Functions  | Configurations  |  |  |
|-----------------------------|-----------------|--|--|
| AUX 21 SWEEP <sup>4</sup>   | X <sup>18</sup> |  |  |
| AUX 22 VFBURST <sup>4</sup> | X <sup>19</sup> |  |  |
| AUX 23 PRT OPT <sup>4</sup> | X <sup>20</sup> |  |  |

NOTE: m/n = m or n. m,n = m and n.

- 1 Requires DSU-DP Option.
- 2 Requires BERT Option.
- 3 Only used with MODE T1-D4.
- 4 Requires VF Option.
- 5 Only used with SCI FREQ.
- 6 Only used with SCI LEVEL and SWEEP.
- 7 Only used with SCIPAR.
- 8 Only used with SCI 3 TONE SLP.
- 9 Only used with SCI 2713 Hz.
- 10 Only used with SCI BYTE.
- 11 Requires IEEE-488 Option.
- 12 Only used with SCI NON CONTIG.
- 13 Only used with SCI DSU-DP and not DS064.
- 14 BPV error insertion only.
- 15 No logic error insertion in SCI DSU-DP.
- 16 Not used with SCI DSU-DP and DS064.
- 17 Requires Enhanced ESF/SLC Option.
- 18 Only used with SCI SWEEP.
- 19 Only used with SCI ERL, SRL-HI, and SRL-LO.
- 20 Used with 1004 Hz, QUIET, FREQ, LEVEL, SWEEP, 3 TONE SLP, and 2713 Hz.

Table E-2  
T1SCL96 Mode Switch Configurations and AUX Functions

| Switches and AUX Functions          |                                                                                                                                                   | Configurations                |                                                                                                                                                                            |                                                                                                                                                                            |                                                                                                                                                                |                                                     |  |
|-------------------------------------|---------------------------------------------------------------------------------------------------------------------------------------------------|-------------------------------|----------------------------------------------------------------------------------------------------------------------------------------------------------------------------|----------------------------------------------------------------------------------------------------------------------------------------------------------------------------|----------------------------------------------------------------------------------------------------------------------------------------------------------------|-----------------------------------------------------|--|
| MODE Switch                         |                                                                                                                                                   | T1SCL96                       |                                                                                                                                                                            |                                                                                                                                                                            |                                                                                                                                                                |                                                     |  |
| CHANNEL FORMAT Switch               | VF<br>VF THRU                                                                                                                                     | DS0                           | DS0A2.4 1/2<br>DS0A4.8 1/2<br>DS0A9.6 1/2<br>DS019.2 1/2<br>DS0A56 1/2<br>DS064 1/2                                                                                        | DS0B2.4 1/2<br>DS0B4.8 1/2<br>DS0B9.6 1/2                                                                                                                                  | FULL T1 2                                                                                                                                                      | DATLINK 3                                           |  |
| SOURCE CONFIGURATION 1 Switch (SCI) | 1004 Hz<br>VF INTF<br>DROP CHAN<br>QUIET 4<br>FREQ 4<br>ERL 4<br>SRL-HI 4<br>SRL-LO 4<br>LEVEL 4<br>SWEEP 4<br>PAR 4<br>3 TONE SLP 4<br>2713 Hz 4 | BYTE<br>DS0 INTF<br>DROP CHAN | DSU-DP 1<br>ALL ONES 2<br>ALL ZERO 2<br>USER 2<br>MIN/MAX 2<br>2*23-1 2<br>2*20-1 2<br>2*15-1 2<br>2*15-1 INV 2<br>CRSS 2<br>3 IN 24 2<br>1:7 2<br>63 2<br>511 2<br>2047 2 | DSU-DP 1<br>ALL ONES 2<br>ALL ZERO 2<br>USER 2<br>MIN/MAX 2<br>2*23-1 2<br>2*20-1 2<br>2*15-1 2<br>2*15-1 INV 2<br>CRSS 2<br>3 IN 24 2<br>1:7 2<br>63 2<br>511 2<br>2047 2 | ALL ONES 2<br>ALL ZERO 2<br>USER 2<br>MIN/MAX 2<br>2*23-1 2<br>2*20-1 2<br>2*15-1 2<br>2*15-1 INV 2<br>CRSS 2<br>3 IN 24 2<br>1:7 2<br>63 2<br>511 2<br>2047 2 | FAR END LP 3<br>MAJ ALM 3<br>MIN ALM 3<br>PWRMISC 3 |  |



Table E-2  
T1SLC96 Mode Switch Configurations and AUX Functions (Continued)

| Switches and AUX Functions                  | XXXX XXXX <sup>10</sup>                                                                                                                                                                    | Configurations                                                                        |                                                                                                                                     |
|---------------------------------------------|--------------------------------------------------------------------------------------------------------------------------------------------------------------------------------------------|---------------------------------------------------------------------------------------|-------------------------------------------------------------------------------------------------------------------------------------|
| SOURCE<br>CONFIGURATION II<br>Switch (SCII) | 20 - 3904 Hz <sup>5</sup><br>-40.0 - +3.0 dBm <sup>6</sup><br>-10.0 - -40.0 dBm <sup>7</sup><br>404 Hz <sup>8</sup><br>1004 Hz <sup>8</sup><br>2804 Hz <sup>8</sup><br>OFF/ON <sup>9</sup> | CHAN 1 - 20 <sup>1/2</sup><br>CHAN 1 - 10 <sup>1/2</sup><br>CHAN 1 - 5 <sup>1/2</sup> | SHELF A <sup>3,11</sup><br>SHELF B <sup>3,11</sup><br>SHELF C <sup>3,11</sup><br>SHELF D <sup>3,11</sup><br>PROTECT <sup>3,12</sup> |
| AUX 01 CL FIFO                              | X                                                                                                                                                                                          | X                                                                                     | X                                                                                                                                   |
| AUX 02 TIM PRI                              | X                                                                                                                                                                                          | X                                                                                     | X                                                                                                                                   |
| AUX 03 TES LEN                              | X                                                                                                                                                                                          | X                                                                                     | X                                                                                                                                   |
| AUX 04 TIM/DAY                              | X                                                                                                                                                                                          | X                                                                                     | X                                                                                                                                   |
| AUX 05 LBO                                  | X                                                                                                                                                                                          | X                                                                                     | X                                                                                                                                   |
| AUX 06 BACK TM                              | X                                                                                                                                                                                          | X                                                                                     | X                                                                                                                                   |
| AUX 07 DS0 TM                               | X                                                                                                                                                                                          | X                                                                                     | X                                                                                                                                   |
| AUX 08 RS 232                               | X                                                                                                                                                                                          | X                                                                                     | X                                                                                                                                   |
| AUX 09 488MODE <sup>13</sup>                | X                                                                                                                                                                                          | X                                                                                     | X                                                                                                                                   |
| AUX 10 N-CONTG <sup>1/2</sup>               |                                                                                                                                                                                            |                                                                                       |                                                                                                                                     |
| AUX 11 ANL CHA <sup>1</sup>                 |                                                                                                                                                                                            | X <sup>14</sup>                                                                       |                                                                                                                                     |
| AUX 12 ERR COR <sup>1/2</sup>               |                                                                                                                                                                                            | X                                                                                     |                                                                                                                                     |
| AUX 13 ERR RT <sup>2</sup>                  | X <sup>15</sup>                                                                                                                                                                            | X <sup>16</sup>                                                                       | X                                                                                                                                   |
| AUX 14 FRM ERR <sup>2</sup>                 | X                                                                                                                                                                                          | X                                                                                     | X                                                                                                                                   |
| AUX 15 USER <sup>2</sup>                    |                                                                                                                                                                                            | X                                                                                     | X                                                                                                                                   |
| AUX 16 PGM LP <sup>2</sup>                  |                                                                                                                                                                                            | X                                                                                     | X                                                                                                                                   |
| AUX 17 LOOP CD <sup>2</sup>                 |                                                                                                                                                                                            | X                                                                                     | X                                                                                                                                   |
| AUX 18 AUTO RES <sup>2</sup>                |                                                                                                                                                                                            | X                                                                                     | X                                                                                                                                   |
| AUX 19 DDS CHN <sup>2</sup>                 |                                                                                                                                                                                            | X <sup>17</sup>                                                                       | X                                                                                                                                   |
| AUX 20 PRM TX <sup>18</sup>                 |                                                                                                                                                                                            |                                                                                       |                                                                                                                                     |

Table E-2  
T1SLC96 Mode Switch Configurations and AUX Functions (Continued)

| Switches and AUX Functions  | Configurations  |  |  |
|-----------------------------|-----------------|--|--|
| AUX 21 SWEEP <sup>4</sup>   | X <sup>19</sup> |  |  |
| AUX 22 VFBURST <sup>4</sup> | X <sup>20</sup> |  |  |
| AUX 23 PRT OPT <sup>4</sup> | X <sup>21</sup> |  |  |

NOTE: m/n = m or n, m, n = m and n.

- 1 Requires DSU-DP Option.
- 2 Requires BERT Option.
- 3 Requires Enhanced ESF/SLC Option.
- 4 Requires VF Option.
- 5 Only used with SCI FREQ.
- 6 Only used with SCI LEVEL and SWEEP.
- 7 Only used with SCI PAR.
- 8 Only used with SCI 3 TONE SLP.
- 9 Only used with SCI 2713 Hz.
- 10 Only used with SCI BYTE.
- 11 Only used with SCI FAR END LP and MAJ ALM.
- 12 Only used with SCI FAR END LP.
- 13 Requires IEEE-488 Option.
- 14 Only used with SCI DSU-DP and not DS064.
- 15 BPV error insertion only.
- 16 No logic error insertion in SCI DSU-DP.
- 17 Not used with SCI DSU-DP and DS064.
- 18 Requires Enhanced ESF/SLC Option.
- 19 Only used with SCI SWEEP.
- 20 Only used with SCI ERL, SRL-HI, and SRL-LO.
- 21 Used with 1004 Hz, QUIET, FREQ, LEVEL, SWEEP, 3 TONE SLP, and 2713 Hz.

Table E-3  
T1-ESF or T1-ESFz Mode Switch Configurations and AUX Functions

| Switches and AUX Functions          |                                                                                                                                                                                                                                                                 | Configurations                 |                                                                                                                                                                                                                                                                                                                                                                                                                                                          |                                                                                                                                                                                                                                                                                                                                                                                                                                                          |                                                                                                                                                                                                                                                                                                                                                                                                                                                          |                                                                                                                                                                                                                                                                                                                                                                                                                                   |
|-------------------------------------|-----------------------------------------------------------------------------------------------------------------------------------------------------------------------------------------------------------------------------------------------------------------|--------------------------------|----------------------------------------------------------------------------------------------------------------------------------------------------------------------------------------------------------------------------------------------------------------------------------------------------------------------------------------------------------------------------------------------------------------------------------------------------------|----------------------------------------------------------------------------------------------------------------------------------------------------------------------------------------------------------------------------------------------------------------------------------------------------------------------------------------------------------------------------------------------------------------------------------------------------------|----------------------------------------------------------------------------------------------------------------------------------------------------------------------------------------------------------------------------------------------------------------------------------------------------------------------------------------------------------------------------------------------------------------------------------------------------------|-----------------------------------------------------------------------------------------------------------------------------------------------------------------------------------------------------------------------------------------------------------------------------------------------------------------------------------------------------------------------------------------------------------------------------------|
|                                     |                                                                                                                                                                                                                                                                 | T1-ESF or T1-ESFz <sup>1</sup> |                                                                                                                                                                                                                                                                                                                                                                                                                                                          |                                                                                                                                                                                                                                                                                                                                                                                                                                                          |                                                                                                                                                                                                                                                                                                                                                                                                                                                          |                                                                                                                                                                                                                                                                                                                                                                                                                                   |
| MODE Switch                         |                                                                                                                                                                                                                                                                 |                                |                                                                                                                                                                                                                                                                                                                                                                                                                                                          |                                                                                                                                                                                                                                                                                                                                                                                                                                                          |                                                                                                                                                                                                                                                                                                                                                                                                                                                          |                                                                                                                                                                                                                                                                                                                                                                                                                                   |
| CHANNEL FORMAT Switch               | VF<br>VF THRU                                                                                                                                                                                                                                                   | DS0                            | DS0A2.4 <sup>2/3</sup><br>DS0A4.8 <sup>2/3</sup><br>DS0A9.6 <sup>2/3</sup><br>DS019.2 <sup>2/3</sup><br>DS0A36 <sup>2/3</sup><br>DS064 <sup>2/3</sup><br>DATLINK <sup>2/3</sup>                                                                                                                                                                                                                                                                          | DS0B2.4 <sup>2/3</sup><br>DS0B4.8 <sup>2/3</sup><br>DS0B9.6 <sup>2/3</sup>                                                                                                                                                                                                                                                                                                                                                                               | 56 x N <sup>2/3</sup><br>64 x N <sup>2/3</sup>                                                                                                                                                                                                                                                                                                                                                                                                           | FULL T1 <sup>3</sup>                                                                                                                                                                                                                                                                                                                                                                                                              |
| SOURCE CONFIGURATION I Switch (SCI) | 1004 Hz<br>VF INTF<br>DROP CHAN<br>QUIET <sup>4</sup><br>FREQ <sup>4</sup><br>ERL <sup>4</sup><br>SRL-HI <sup>4</sup><br>SRL-LO <sup>4</sup><br>LEVEL <sup>4</sup><br>SWEEP <sup>4</sup><br>PAR <sup>4</sup><br>3 TONE SLP <sup>4</sup><br>2713 Hz <sup>4</sup> | BYTE<br>DS0 INTF<br>DROP CHAN  | DSU-DP <sup>2</sup><br>ALL ONES <sup>3</sup><br>ALL ZERO <sup>3</sup><br>USER <sup>3</sup><br>MIN/MAX <sup>3</sup><br>2*23-1 <sup>3</sup><br>2*20-1 <sup>3</sup><br>2*15-1 <sup>3</sup><br>2*15-1 INV <sup>3</sup><br>QRSS <sup>3</sup><br>3 IN 24 <sup>3</sup><br>1:7 <sup>3</sup><br>63 <sup>3</sup><br>511 <sup>3</sup><br>2047 <sup>3</sup><br>DDS1 <sup>3</sup><br>DDS2 <sup>3</sup><br>DDS3 <sup>3</sup><br>DDS4 <sup>3</sup><br>AUTO <sup>3</sup> | DSU-DP <sup>2</sup><br>ALL ONES <sup>3</sup><br>ALL ZERO <sup>3</sup><br>USER <sup>3</sup><br>MIN/MAX <sup>3</sup><br>2*23-1 <sup>3</sup><br>2*20-1 <sup>3</sup><br>2*15-1 <sup>3</sup><br>2*15-1 INV <sup>3</sup><br>QRSS <sup>3</sup><br>3 IN 24 <sup>3</sup><br>1:7 <sup>3</sup><br>63 <sup>3</sup><br>511 <sup>3</sup><br>2047 <sup>3</sup><br>DDS1 <sup>3</sup><br>DDS2 <sup>3</sup><br>DDS3 <sup>3</sup><br>DDS4 <sup>3</sup><br>AUTO <sup>3</sup> | DSU-DP <sup>2</sup><br>ALL ONES <sup>3</sup><br>ALL ZERO <sup>3</sup><br>USER <sup>3</sup><br>MIN/MAX <sup>3</sup><br>2*23-1 <sup>3</sup><br>2*20-1 <sup>3</sup><br>2*15-1 <sup>3</sup><br>2*15-1 INV <sup>3</sup><br>QRSS <sup>3</sup><br>3 IN 24 <sup>3</sup><br>1:7 <sup>3</sup><br>63 <sup>3</sup><br>511 <sup>3</sup><br>2047 <sup>3</sup><br>DDS1 <sup>3</sup><br>DDS2 <sup>3</sup><br>DDS3 <sup>3</sup><br>DDS4 <sup>3</sup><br>AUTO <sup>3</sup> | ALL ONES <sup>3</sup><br>ALL ZERO <sup>3</sup><br>USER <sup>3</sup><br>MIN/MAX <sup>3</sup><br>2*23-1 <sup>3</sup><br>2*20-1 <sup>3</sup><br>2*15-1 <sup>3</sup><br>2*15-1 INV <sup>3</sup><br>QRSS <sup>3</sup><br>3 IN 24 <sup>3</sup><br>1:7 <sup>3</sup><br>63 <sup>3</sup><br>511 <sup>3</sup><br>2047 <sup>3</sup><br>DDS1 <sup>3</sup><br>DDS2 <sup>3</sup><br>DDS3 <sup>3</sup><br>DDS4 <sup>3</sup><br>AUTO <sup>3</sup> |

Table E-3  
T1-ESF or T1-ESFz Mode Switch Configurations and AUX Functions (Continued)

| Switches and AUX Functions    | 20 - 3904 Hz <sup>5</sup><br>-40.0 - +3.0 dBm <sup>6</sup><br>-10.0 - -40.0 dBm <sup>7</sup><br>404 Hz <sup>6</sup><br>1004 Hz <sup>6</sup><br>2804 Hz <sup>8</sup><br>OFF/ON <sup>5</sup> | XXXX XXXX <sup>10</sup> | Configurations                                                                     |                 | N = 1 - 24 <sup>23</sup><br>NON CONTIG <sup>23</sup> |
|-------------------------------|--------------------------------------------------------------------------------------------------------------------------------------------------------------------------------------------|-------------------------|------------------------------------------------------------------------------------|-----------------|------------------------------------------------------|
|                               |                                                                                                                                                                                            |                         | CHAN 1 - 20 <sup>23</sup><br>CHAN 1 - 10 <sup>23</sup><br>CHAN 1 - 5 <sup>23</sup> |                 |                                                      |
| AUX 01 CL FIFO                | X                                                                                                                                                                                          | X                       | X                                                                                  | X               | X                                                    |
| AUX 02 TIM PRI                | X                                                                                                                                                                                          | X                       | X                                                                                  | X               | X                                                    |
| AUX 03 TES LEN                | X                                                                                                                                                                                          | X                       | X                                                                                  | X               | X                                                    |
| AUX 04 TIM/DAY                | X                                                                                                                                                                                          | X                       | X                                                                                  | X               | X                                                    |
| AUX 05 LBO                    | X                                                                                                                                                                                          | X                       | X                                                                                  | X               | X                                                    |
| AUX 06 BACK TM                | X                                                                                                                                                                                          | X                       | X                                                                                  | X               | X                                                    |
| AUX 07 DSO TM                 | X                                                                                                                                                                                          | X                       | X                                                                                  | X               | X                                                    |
| AUX 08 RS 232                 | X                                                                                                                                                                                          | X                       | X                                                                                  | X               | X                                                    |
| AUX 09 488MODE <sup>11</sup>  | X                                                                                                                                                                                          | X                       | X                                                                                  | X               | X                                                    |
| AUX 10 N-CONTG <sup>23</sup>  |                                                                                                                                                                                            |                         |                                                                                    | X <sup>12</sup> |                                                      |
| AUX 11 ANL CHA <sup>2</sup>   |                                                                                                                                                                                            | X <sup>13</sup>         | X <sup>13</sup>                                                                    |                 |                                                      |
| AUX 12 ERR COR <sup>2/3</sup> |                                                                                                                                                                                            | X                       | X                                                                                  |                 |                                                      |
| AUX 13 ERR RT <sup>3</sup>    | X <sup>14</sup>                                                                                                                                                                            | X <sup>14</sup>         | X <sup>15</sup>                                                                    | X <sup>15</sup> | X                                                    |
| AUX 14 FRM ERR <sup>3</sup>   | X                                                                                                                                                                                          | X                       | X                                                                                  | X               | X                                                    |
| AUX 15 USER <sup>3</sup>      |                                                                                                                                                                                            | X                       | X                                                                                  | X               | X                                                    |
| AUX 16 PGM LP <sup>3</sup>    |                                                                                                                                                                                            | X                       | X                                                                                  | X               | X                                                    |
| AUX 17 LOOP CD <sup>3</sup>   |                                                                                                                                                                                            | X                       | X                                                                                  | X               | X                                                    |
| AUX 18 AUTO RES <sup>3</sup>  |                                                                                                                                                                                            | X                       | X                                                                                  | X               | X                                                    |
| AUX 19 DDS CHN <sup>3</sup>   |                                                                                                                                                                                            | X <sup>16</sup>         | X <sup>16</sup>                                                                    | X <sup>16</sup> | X                                                    |
| AUX 20 PRM TX <sup>17</sup>   | X                                                                                                                                                                                          | X                       | X                                                                                  | X               | X                                                    |

Table E-3  
T1-ESF or T1-ESFz Mode Switch Configurations and AUX Functions (Continued)

| Switches and AUX Functions | Configurations  |  |  |
|----------------------------|-----------------|--|--|
| AUX 21 SWEEP 5             | X <sup>18</sup> |  |  |
| AUX 22 VFBURST 5           | X <sup>19</sup> |  |  |
| AUX 23 PRT OPT 5           | X <sup>20</sup> |  |  |

NOTE: m/n = m or n. m,n = m and n.

- 1 Requires ZBTSI Option.
- 2 Requires DSU-DP Option.
- 3 Requires BERT Option.
- 4 Requires VF Option.
- 5 Only used with SCI FREQ.
- 6 Only used with SCI LEVEL and SWEEP.
- 7 Only used with SCI PAR.
- 8 Only used with SCI 3 TONE SLP.
- 9 Only used with SCI 2713 Hz.
- 10 Only used with SCI BYTE.
- 11 Requires IEEE-488 Option.
- 12 Only used with SCI NON CONTIG.
- 13 Only used with SCI DSU-DP and not DS064 or DATLINK.
- 14 BPV error insertion only.
- 15 No logic error insertion in SCI DSU-DP.
- 16 Not used with SCI DSU-DP, DS064, and DATLINK.
- 17 Requires Enhanced ESF/SLC Option.
- 18 Only used with SCI SWEEP.
- 19 Only used with SCI ERL, SRL-HI, and SRL-LO.
- 20 Used with 1004 Hz, QUIET, FREQ, LEVEL, SWEEP, 3 TONE SLP, and 2713 Hz.

**Table E-4**  
**T1 Mode Switch**  
**Configurations and AUX**  
**Functions**

| Switches and AUX Functions            | Configur-<br>ation                                                                                                                                                                                                                                                                                                                                                                                                                                                                    |
|---------------------------------------|---------------------------------------------------------------------------------------------------------------------------------------------------------------------------------------------------------------------------------------------------------------------------------------------------------------------------------------------------------------------------------------------------------------------------------------------------------------------------------------|
| MODE Switch                           | T1 <sup>1</sup>                                                                                                                                                                                                                                                                                                                                                                                                                                                                       |
| CHANNEL FORMAT Switch                 | FULL T1 <sup>2</sup>                                                                                                                                                                                                                                                                                                                                                                                                                                                                  |
| SOURCE CONFIGURATION I Switch (SCI)   | ALL ONES <sup>1</sup><br>ALL ZERO <sup>1</sup><br>USER <sup>1</sup><br>MIN/MAX <sup>1</sup><br>2 <sup>A</sup> 23-1 <sup>1</sup><br>2 <sup>A</sup> 20-1 <sup>1</sup><br>2 <sup>A</sup> 15-1 <sup>1</sup><br>2 <sup>A</sup> 15-1 INV <sup>1</sup><br>QRSS <sup>1</sup><br>3 IN 24 <sup>1</sup><br>1:7 <sup>1</sup><br>63 <sup>1</sup><br>511 <sup>1</sup><br>2047 <sup>1</sup><br>DDS1 <sup>1</sup><br>DDS2 <sup>1</sup><br>DDS3 <sup>1</sup><br>DDS4 <sup>1</sup><br>AUTO <sup>1</sup> |
| SOURCE CONFIGURATION II Switch (SCII) |                                                                                                                                                                                                                                                                                                                                                                                                                                                                                       |
| AUX 01 CL FIFO                        | X                                                                                                                                                                                                                                                                                                                                                                                                                                                                                     |
| AUX 02 TIM PRI                        | X                                                                                                                                                                                                                                                                                                                                                                                                                                                                                     |
| AUX 03 TES LEN                        | X                                                                                                                                                                                                                                                                                                                                                                                                                                                                                     |

| Switches and AUX Functions    | Configur-<br>ation |
|-------------------------------|--------------------|
| AUX 04 TIM/DAY                | X                  |
| AUX 05 LBO                    | X                  |
| AUX 06 BACK TM                | X                  |
| AUX 07 DS0 TM                 |                    |
| AUX 08 RS 232                 | X                  |
| AUX 09 488MODE <sup>3</sup>   | X                  |
| AUX 10 N-CONTG <sup>1/4</sup> |                    |
| AUX 11 ANL CHA <sup>4</sup>   |                    |
| AUX 12 ERR COR <sup>1/4</sup> |                    |
| AUX 13 ERR RT <sup>1</sup>    | X                  |
| AUX 14 FRM ERR <sup>1</sup>   |                    |
| AUX 15 USER <sup>1</sup>      | X                  |
| AUX 16 PGM LP <sup>1</sup>    | X                  |
| AUX 17 LOOP CD <sup>1</sup>   | X                  |
| AUX 18 AUTO RES <sup>1</sup>  | X                  |
| AUX 19 DDS CHN <sup>1</sup>   |                    |
| AUX 20 PRM TX <sup>5</sup>    |                    |
| AUX 21 SWEEP <sup>6</sup>     |                    |
| AUX 22 VFBURST <sup>6</sup>   |                    |
| AUX 23 PRT OPT <sup>6</sup>   |                    |

NOTE: m/n = m or n. m,n = m and n.

<sup>1</sup> Requires BERT Option.

<sup>2</sup> Default channel format.

<sup>3</sup> Requires IEEE-488 Option.

<sup>4</sup> Requires DSU-DP Option.

<sup>5</sup> Requires Enhanced ESF/SLC Option.

<sup>6</sup> Requires VF Option.

Table E-5  
T-BERD 224 Loopback Modes

| Received Signal Framing | Refer to Table   | AUTOLLB <sup>1</sup> | T1 LLB <sup>2</sup> | T1 TLB <sup>2</sup> | AUTOPLB <sup>1</sup> | FT1 LLB <sup>1</sup> |
|-------------------------|------------------|----------------------|---------------------|---------------------|----------------------|----------------------|
| D1D <sup>3</sup>        | E-1 <sup>4</sup> | X                    | X                   | X                   |                      |                      |
| D2 <sup>3</sup>         | E-1 <sup>4</sup> | X                    | X                   | X                   |                      |                      |
| D4                      | E-1 <sup>4</sup> | X                    | X                   | X                   |                      | X                    |
| ESF                     | E-3 <sup>4</sup> | X                    | X                   | X                   | X                    | X                    |
| ESFz                    | E-3 <sup>4</sup> | X                    | X                   | X                   | X                    | X                    |
| SLC-96                  | E-2 <sup>4</sup> | X                    | X                   | X                   |                      |                      |
| Unframed T1             | E-4              | X                    | X                   | X                   |                      |                      |

<sup>1</sup> Displayed when AUX 18 AUTO RES is set to AUTO RESP and unit detects framing.

<sup>2</sup> Select with MODE switch.

<sup>3</sup> Unit configures itself to D4 framing.

<sup>4</sup> SCI 1004 Hz and DROP CHAN not available in VF or VF THRU channel format. SCI BYTE and DROP CHAN not available in DS0 channel format.