

50-12257-01
Rev. P

T-BERD 209A/211 T-CARRIER ANALYZER

USER'S GUIDE

JUNE 1994

**©1992 TELECOMMUNICATIONS TECHNIQUES CORPORATION®
20400 Observation Drive
Germantown, MD 20876
(301) 353-1550 (MD) • (800) 638-2049 • FAX (301) 353-0731
WWW Address: <http://www.ttc.com>**

TABLE OF CONTENTS

SECTION	PAGE
INTRODUCTION	1
BASIC SETUPS	
1. GENERATING PRINTOUTS	3
2. CONFIGURING FOR A TIMED TEST	5
TESTING T1 NETWORKS	
3. MONITORING T1 PERFORMANCE	7
4. MEASURING T1 TIMING SLIPS AND WANDER	11
5. LOOPBACK TESTING FROM A DSX-1 PATCH PANEL	15
6. LOOPBACK TESTING AT MID-SPAN	27
7. EMULATING A CSU AT CUSTOMER PREMISES	33
TDR TESTING	
8. TDR TESTING	39
ADVANCED TESTING	
9. MONITORING ESF PRMS	43
10. MONITORING DS0 CHANNELS	46
11. TESTING FRACTIONAL T1 NETWORKS	50
12. REMOTE TESTING WITH AN NIU/PERFORMANCE MONITOR	54
13. TESTING INTELLIGENT REPEATER SPANS	59
TESTING NEWLY INSTALLED T1 SPANS	
14. TESTING FROM THE MDF	67
15. TESTING FROM MID-SPAN	74
TESTING DIGITAL LOOP CARRIER (DLC) NETWORKS	
16. MONITORING DIGITAL LOOP CARRIER (DLC) SHELF OPERATION	79
17. TESTING SHELF A RT OPERATION	84
18. TESTING RT DATALINK OPERATION	90
19. TESTING SHELF B, C, D, OR PROTECT BER PERFORMANCE	98
20. VERIFYING RING GENERATION	104

SECTION	PAGE
21. VERIFYING CHANNEL UNIT SIGNALING	108
22. CHECKING SLC MODE 2 TIMESLOT MAPPING	113

FIGURES

1. MONITORING T1 PERFORMANCE	8
2. MEASURING T1 TIMING SLIPS	11
3. TIMING SLIP BAR GRAPH AND WHEEL DISPLAY	13
4. LOOPBACK TESTING FROM A DSX-1 PATCH PANEL	16
5. T1 PULSE SHAPE AND PULSE MASK SPECIFICATIONS	21
6. T1 PULSE SHAPE GRAPH	24
7. T1 JITTER VS. FREQUENCY GRAPH	25
8. MID-SPAN TESTING TOWARD CENTRAL OFFICE	29
9. MID-SPAN TESTING TOWARD CUSTOMER PREMISES	29
10. EMULATING A CSU AT THE CUSTOMER PREMISES	34
11. TDR TEST SETUP	39
12. SINGLE TRACE TDR GRAPH	41
13. DUAL TRACE TDR GRAPH	42
14. TDR CONTROLS AND RESULTS PRINTOUTS	42
15. MONITORING T1 ESF CIRCUIT PRMS	43
16. MONITORING T1 AND DS0 SIGNALS	47
17. FT1 CIRCUIT TESTING	51
18. NIU/PERFORMANCE MONITOR TESTING	55
19. INTELLIGENT REPEATER SPAN TEST SETUP	59
20. TEST SETUP AT THE MDF	67
21. TESTING FROM MID-SPAN	76
22. MONITORING DLC SHELF OPERATION	80
23. TESTING SHELF A RT OPERATION	85
24. TESTING SHELF A RT OPERATION	89
25. TESTING REMOTE TERMINAL DATALINK OPERATION	92
26. TESTING SHELF B, C, D, OR PROTECT BER PERFORMANCE	99
27. TESTING RING GENERATORS	105
28. VERIFYING CHANNEL UNIT SIGNALING	109
29. CHECKING SLC MODE 2 TIMESLOT MAPPING	114

TABLE OF CONTENTS

TABLES	PAGE
1. MULTIPAT AND BRIDGTAP TEST RESULTS	20
2. SPECTRAL ANALYSIS RESULTS AND AUXILIARY FUNCTIONS	23
3. TYPICAL REPEATER VOLTAGE DROP	69
4. TYPICAL CABLE GAUGE VOLTAGE DROP	69

TABLE OF CONTENTS

INTRODUCTION

The *T-BERD 209A/211 User's Guide* presents the most often used T-BERD 209A/211 test setups in complete and concise steps. Illustrations, helpful notes, and step-by-step procedures make this manual a unique aid for novice and experienced users alike.

If you are unfamiliar with the instrument, refer to the *T-BERD 209A/211 Reference Manual* for more detailed information. If you require additional help, call TTC Customer Service at (800) 638-2049.

The user's guide is divided into the following sections:

BASIC SETUPS — Describes setup procedures to generate printouts and perform timed tests with the T-BERD 209A/211.

TESTING T1 NETWORKS — Describes several T-BERD 209A/211 standard applications. Each application describes how to configure the T-BERD 209A/211 mainframe, connect to the circuit being tested, and interpret the test results.

TDR TESTING — Provides instructions to set up and use the TDR Option to identify and locate cable problems on T1 span cable sections.

ADVANCED TESTING — Describes setup procedures and results interpretation for several T-BERD 209A/211 advanced options, including the Enhanced ESF Option, FT1 Option, Channel Monitor Option, and Advanced BERT Option.

TESTING NEWLY INSTALLED T1 SPANS — Presents applications that use the T-BERD Repeater Power Supply to power a new T1 span and use the T-BERD 209A/211 to test the span. Each application describes how to configure the T-BERD Repeater Power Supply, configure the T-BERD 209A/211 mainframe, connect to the circuit being tested, and interpret the test results.

TESTING DIGITAL LOOP CARRIER (DLC) NETWORKS
Describes setup procedures and results interpretation for testing DLC networks using the T-BERD 209A/211 DLC Analyzer Lid Option.

INTRODUCTION

Some T-BERD 209A/211 applications use one or more of the T-BERD 209A/211 options. If an option is required, the mainframe and option setup procedures are subdivided, and the option is indicated in the title of the application.

- * G.821 Performance Analysis Option (209A/211-1)
- * Jitter Spectral Analysis Option (211-2)
- * Rechargeable Lead-Acid Battery Option (209A-2)
- * Advanced BERT Option (209A/211-3)
- * Enhanced ESF Option (209A/211-4)
- * Time Domain Reflectometer Option (209A/211-5)
- * Fractional T1 Option (209A/211-6)
- * T-BERD DLC Analyzer Option (209A/211-96)
- * T-BERD T1 Channel Monitor Option (Model 40849)
- * T-BERD Repeater Power Supply Option (Model 41084)

1. GENERATING PRINTOUTS***TTC PR-40A Thermal Printer or Equivalent Required***

Perform the following procedure to configure the T-BERD 209A/211 and a compatible printer, such as the TTC PR-40A Thermal Printer, to generate printouts. The printer connection is on the side panel. If a printer is not available, you can generate and store printouts in the internal print buffer.

1. **MODE switch**
Select the AUX mode.
2. **PATTERN switch**
Set the following auxiliary functions:

AUX Function	Selections	Comments
BAUD	300, 1200, 2400, or 4800	Set baud rate to match the printer (2400 baud for PR-40A).
PARITY	NONE, ODD, or EVEN	Set parity to NONE when printing graphs.
PRNT FMT	SHORTFORMAT, NORMAL FORMAT, SUMMARY PRINT	Select the results printout format.
TERM	CR or CRLF	Set the printout line terminator. Use CR when printing graphs.

BASIC SETUP

3. **MODE switch**
Exit the auxiliary functions.
4. **Connect a printer to the T-BERD 209A/211**
Connect an RS-232 serial cable between the printer and the T-BERD 209A/211.
5. **PRINT switch**
Select the CONTROLS position to generate a controls printout and verify proper operation of the printer interface.
6. **PRINT EVENT switch**
Select the print event function to generate appropriate results printouts. Printouts for pulse shape, TDR, and jitter spectral analysis graphs are described in the appropriate application.

2. CONFIGURING FOR A TIMED TEST

Perform the following procedure to set up the T-BERD 209A/211 to run an unattended test for an extended period and collect test results during and after the test. Specific results printouts are generated when test conditions match the selected print event setting of the **PRINT EVENT** switch.

1. **Connect compatible printer (optional step)**
If you are connecting a printer, refer to *Application 1, Generating Printouts*. If you are not connecting a printer, skip to Step 2.

2. **PRINT EVENT switch (optional step)**
To generate a test-end results printout at the end of the timed test, select TEST END. To generate periodic results printouts, select one of the time settings (2 HR or 15 MIN). To generate errored results printouts, select either ERROR or SEV ERR SEC. If a printer is not connected to the T-BERD 209A/211, the printouts are stored in the print buffer (NOVRAM).

If you not generating any printouts, skip to Step 3.

3. **MODE switch**
Select the AUX mode.

4. **PATTERN switch**
Select AUX TEST LEN to set the desired duration.

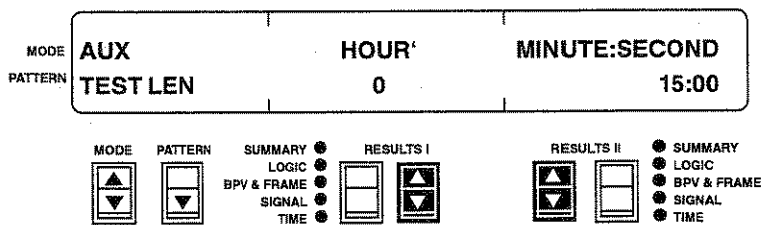

BASIC SETUP

5. **MODE switch**
Exit the auxiliary functions.
6. **TEST switch**
Select **TIMED** test. Selecting the **TIMED** test restarts the test.
7. **RESULTS switches**
Scroll to the **TIME** category 64-TEST END IN result in the **RESULTS I** window and the **SUMMARY** category in the **RESULTS II** window.

When the 64-TEST END IN result equals 00:00:00, the test is complete. *TIMED TEST COMPLETE* flashes alternately with the test result in the **RESULTS I** window, and the test result counts are frozen.

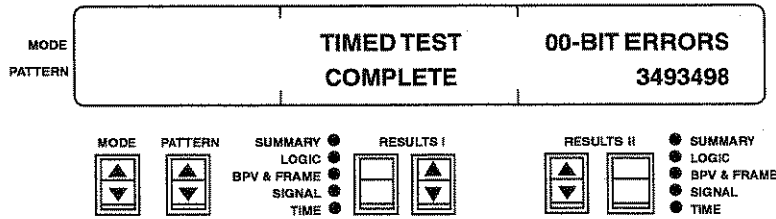

3. MONITORING T1 PERFORMANCE

- * Non-intrusively monitors the T1 facility.
- * Confirms that the T1 signal is properly received by the network equipment.
- * Measures the T1 signal level and frequency.
- * Measures the T1 signal for the current and maximum peak-to-peak wideband and highband jitter (T-BERD 211 only).

1. **Configure the T-BERD 209A/211 switches:**

MODE	Scroll to AUTO mode
TEST	CONT
CODE	AMI or B8ZS, as appropriate
RECEIVE INPUT	DSX-MON

2. **RECEIVE jack**

Connect a cable between this jack and the span-side DSX-1 MON jack (see Figure 1).

3. **Press the RESTART switch**

Verify received framing format and pattern (or *live*) appear in lowercase characters in the MODE and PATTERN windows, respectively.

4. **Status LEDs**

These LEDs should illuminate: T1 Pulses, Frame Sync, and B8ZS (if applicable).

5. **RESULTS | switches**

Select the SUMMARY category. If *ALL RESULTS OK* is displayed and no Alarm LEDs are illuminated, the circuit is operating within specifications. If errors are detected, scroll through the SUMMARY category results for specific errors. Check the other categories as required.

T1 TESTING
APPLICATIONS

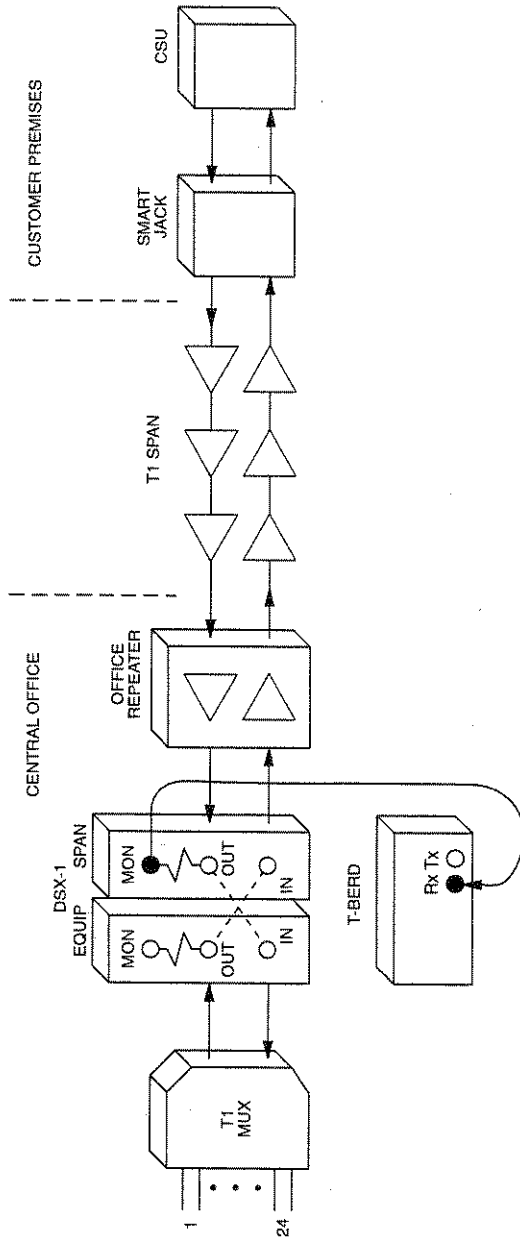

Figure 1
Monitoring T1 Performance

6. **Results interpretation**

Standard BERT Testing

25-VIOLATIONS

These errors typically indicate a local T1 span problem caused by a bad splice, water on the cable, crosstalk, or defective DSX jacks.

30-FRM ERRORS and 32-CRC ERRORS (ESF framing only)

These errors typically indicate a span line problem between you and the last piece of transmission equipment that framed the signal.

40-RX FREQ, Hz

The DS1 received frequency should be 1.544 MHz \pm 58 Hz or 208 Hz for older transmission equipment. If the frequency is out-of-specification, check the transmission equipment timing or network synchronization.

41-RX LEVEL (dBdsx)

The received level should be -20 dBdsx \pm 3.5 dBdsx at resistor isolated DSX-1 MON jacks. Incorrect levels could be caused by a faulty T1 line card or poor cabling between the DSX jack and the equipment.

Yellow Alarm LED

This alarm LED indicates a problem in the transmission leg of the span.

Jitter Testing (T-BERD 211 Only)

25-VIOLATIONS, 30-FRM ERRORS, and 32-CRC ERRORS (ESF framing only)

Excessive jitter causes BPVs, frame errors, and CRC errors.

T1 TESTING

APPLICATIONS

41-RX LEVEL (dBdsx)

The received level should be 16 dBdsx to -24 dBdsx at resistor isolated DSX-1 MON jacks to measure the T1 jitter. Levels outside this range cause the message *OUT OF RANGE* to appear in the jitter results.

80-WB/HB JIT

Check this result to determine if the wideband and highband jitter and the signal level are within specifications.

PASS — appears when the wideband jitter is less than 5.0 UI and highband jitter is less than 0.1 UI. The signal level is within prescribed limits.

FAILED — appears when the wideband jitter is greater than 5.0 UI and highband jitter is greater than 0.1 UI. The signal level is within prescribed limits.

OUT OF RANGE — appears when the signal level is outside prescribed limits.

81-WB JITTER and 82-HB JITTER

If the 81-WB JITTER result exceed 5.0 UI, then a multiplexer may be causing the excess wideband jitter. Multiplexers often cause waiting time jitter, which appears as low frequency jitter.

If the 82-HB JITTER exceeds 0.1 UI, and the 81-WB JITTER result reads the same value, then a span line problem such as a bad repeater may be causing the jitter.

84-MAX WB JIT and 85-MAX HB JIT

If the history Jitter LED illuminates, but the current Jitter LED is off, the maximum peak-to-peak wideband and highband jitter can be read from these results.

Jitter LED

This LED illuminates when wideband jitter exceeds 5.0 UI or highband jitter exceeds 0.1 UI.

4. MEASURING T1 TIMING SLIPS AND WANDER

- Confirm that all the network equipment is properly synchronized.
- Verify network timing and wander.
- Isolate possible timing problems and wander.

1. **Configure the T-BERD 209A/211 switches:**

MODE	Scroll to AUTO mode.
TEST	CONT.
CODE	AMI or B8ZS, as appropriate
RECEIVE INPUT	DSX-MON

2. **T1 circuit connection**

Connect a cable between the RECEIVE jack and the span-side DSX-1 MON jack. Connect a cable between the T1 REF (TDR) jack and the equipment-side DSX-1 MON jack (see Figure 2).

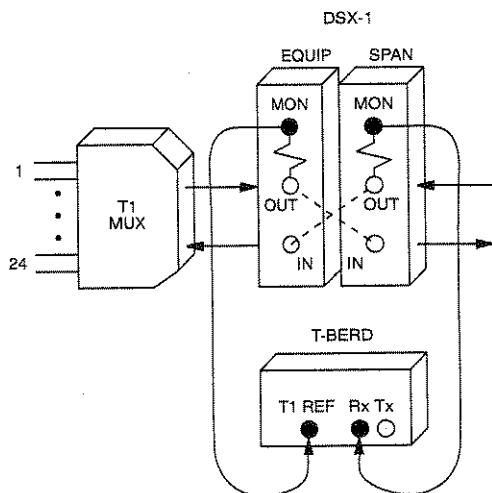

Figure 2
Measuring T1 Timing Slips

T1 TESTING

APPLICATIONS

3. Press the **RESTART** switch

Verify received framing format and pattern (or live) appear in lowercase characters in the **MODE** and **PATTERN** windows, respectively.

4. **Status LEDs**

These LEDs should illuminate: T1 Pulses, Frame Sync, Pattern Sync (if applicable), and B8ZS (if applicable).

5. **RESULTS I switches**

Select the **SUMMARY** category. If errors are not detected, **ALL RESULTS OK** appears. If errors are detected, scroll through the **SUMMARY** category results for specific errors. Check the other categories as required.

6. **RESULTS switches**

Scroll the **RESULTS I** window to the **SIGNAL** category to 53-SLP ANA SEC result and the **RESULTS II** window to the **SIGNAL** category 51-TIMING SLIP result.

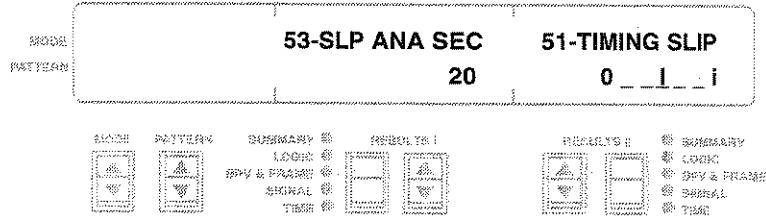

7. **RESULTS switches**

51-TIMING SLIP

The 51-TIMING SLIP result is only available when the timing reference source is connected to either the T1 REF (TDR) jack or the EXT CLK IN connector. Figure 3 shows an expanded view of the bar graph and wheel display. The timing slip count, bar graph, and wheel change rapidly when the frequency differs by more than a few Hertz.

If the T1 reference and receive signals are perfectly synchronized, the timing slip count remains at 0, the bar graph remains centered, and the wheel remains at top center.

T1 TESTING
APPLICATIONS

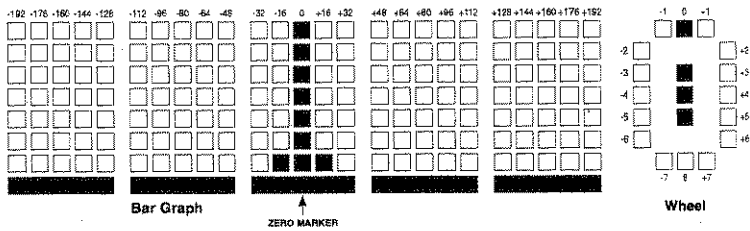

Figure 3
Timing Slip Bar Graph and Wheel Display

If the T1 reference and received signals are not synchronized, and the received signal frequency is higher than the T1 reference signal, the wheel moves clockwise the bar graph moves to the right, and the timing slip count increments every 193 bit slips.

If the T1 reference and received signals are not synchronized, and the received signal frequency is lower than the T1 reference signal, the wheel moves counterclockwise, the bar graph moves to the left, and the timing slip count increments every 193 bit slips.

If the T1 reference and received signals are synchronized, but one signal exhibits low-speed wander (e.g., satellite movement effects), the timing slip count remains at 0. As the satellite approaches, the wheel moves clockwise, and the bar graph moves to the right. As the satellite retreats, the wheel moves counterclockwise, and the bar graph moves the left.

53-SLP ANA SEC

The 53-SLP ANA SEC result increments when both the T1 reference signal and the received T1 signal and the received T1 signal are present and timing slip analysis is being performed.

70-WANDER + PK, 71-WANDER -PK, and 72-P-P WANDER

Positive-peak, negative-peak, and peak-to-peak wander results indicate maximum wander conditions since the beginning of the test. Wander can be monitored to determine whether it exceeds tolerances for the terminal buffers. Wander is measured in Unit Intervals (UIs); 1 UI is equivalent to a single T1 timeslot (or one bit space in a buffer). Wander is a form of jitter that occurs at frequencies of less than 10 Hz.

73-15m WANDER and 74-24h WANDER

The 15-minute and 24-hour wander results indicate the maximum peak-to-peak over the last indicated period. The 15 minute result is not available for the first 15 minutes of the test and is updated once per minute. The 24-hour result is not available for the first 24 hours of the test and is updated once per hour.

73- TIE WANDER

The Time Interval Error wander result is a measurement of the instantaneous displacement of the received T1 signal from the reference signal since the beginning of the test. This result can be positive or negative.

5. LOOPBACK TESTING FROM A DSX-1 PATCH PANEL

- * Qualifies T1 circuit error performance by testing for logic errors, BPVs, frame errors, and CRC errors (if applicable) on T1 lines.
- * Checks loopback response of transmission equipment.
- * Transmits the MULTIPAT® pattern sequence of five Bellcore approved test patterns (ALL ONES, 1:7, 2 IN 8, 3 IN 24, and QRSS) to perform a one-step qualification of T1 span lines.
- * Transmits the BRIDGTAP™ pattern sequence of 21 test patterns composed of varying degrees of ones and zeros densities to detect the presence of most bridge taps on T1 span lines.
- * Measures waveform against standard pulse shape masks (ANSI T1.403, AT&TCB119).
- * Measures the spectral jitter response against a selected jitter mask specification (T-BERD 211 with Jitter Spectral Analysis Option installed only).

NOTE: If intending to use the MULTIPAT and BRIDGTAP automated patterns, use the MULTIPAT pattern sequence first, followed by the BRIDGTAP sequence.

1. Configure the T-BERD 209A/211 switches:

MODE	Scroll to appropriate T1 framing format.
PATTERN	Scroll to desired test pattern (1:7 is recommended for pulse shape testing).
TIMING	INT.
TEST	CONT.
CODE	AMI or B8ZS, as appropriate (if pattern is BRIDGTAP, set to AMI).
RECEIVE INPUT	TERM.

TESTING T1 NETWORKS

APPLICATIONS

TRANSMIT OUTPUT	0dB(DSX).
AUX LP CODE	IN-BAND—CSU, FAC1, FAC2, FAC3, or PGM, as appropriate. OUT-OF-BAND—LINE, PAYLOAD, or NETWORK, as appropriate.
AUX ESF LOOP	If ESF or FT1 ESF mode, ESF LOOP CODE—IN BAND or OUT OF BAND, as desired.
AUX ERR SEL	BPV/LOGIC—SINGLE ERROR.
AUX PLS MASK	PULSE SELECT—DSX (CB119) or NI (ANSI), as appropriate.

If you are using a T-BERD 211 with the Jitter Spectral Analysis Option installed, set the following T-BERD 211 auxiliary functions:

AUX JIT S/A	SPEC ANALYSIS—ON.
AUX JIT MASK	JITTER MASK—Select appropriate jitter mask.
AUX JIT TRIG	TRIGGER EVENT—Select appropriate jitter trigger.

2. T1 circuit connection

Connect a cable from the RECEIVE jack to the span-side DSX-1 OUT jack. Connect a cable from the TRANSMIT jack to the span-side DSX-1 IN jack (see Figure 4).

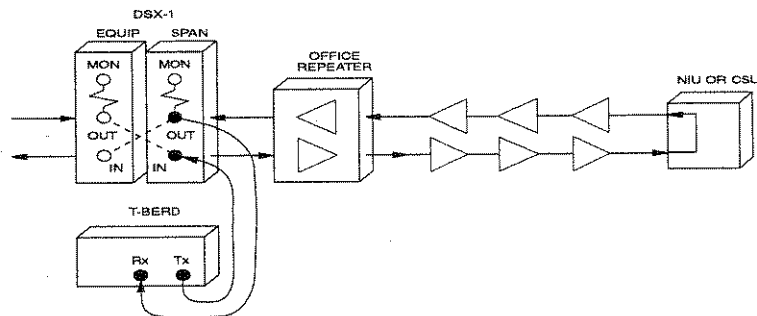
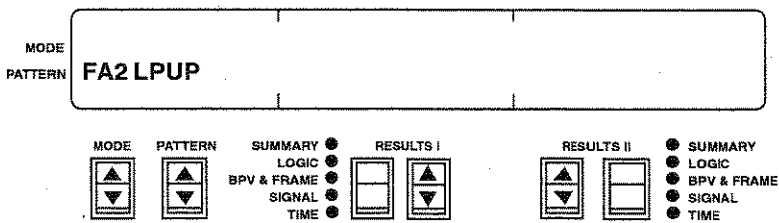

Figure 4
Loopback Testing From a DSX-1 Patch Panel

3. **LOOP UP switch**

Press this switch to send the loop-up code. The switch LED illuminates until the loop code is detected. A loop-up code message appears in the display. The test restarts when the loopback is established.



4. **Status LEDs**

These LEDs should illuminate: T1 Pulses, Frame Sync, Pattern Sync, and B8ZS (if applicable).

5. **RESULTS I Category switch**

Select the SUMMARY category.

6. **LOGIC ERROR INSERT switch**

Press this switch five times to verify the logic errors are received and the T1 circuit is looped back. The 00-BIT ERRORS result should appear in the RESULTS I window showing 5 bit errors.

If the loopback is not established, the bit errors do not appear in the display. The failed loopback could indicate the NIU/CSU is not operating correctly, the line from you to the NIU/CSU is bad, or the transmitted loop code is incorrect.

7. **Press the RESTART switch**

8. **RESULTS I switches**

Check the SUMMARY category. If errors are not detected, *ALL RESULTS OK* appears. If errors are detected, scroll through the SUMMARY category for specific errors. Check the other categories as required.

TESTING T1 NETWORKS
APPLICATIONS

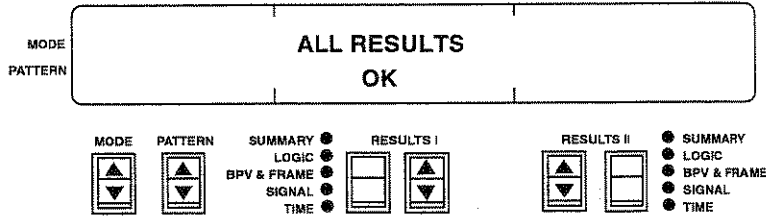

NOTE: If using the MULTIPAT or BRIDGTAP patterns, the PATTERN window alternates between the transmitted test pattern in lowercase characters and MULTIPAT or BRIDGTAP, as appropriate.

9. **Results interpretation**

Standard BERT Testing

00-BIT ERRORS only

Check the span before the DSX-1 by isolating sections and testing.

25-VIOLATIONS only

These errors typically indicate a local T1 span problem caused by a bad splice, water on the cable, crosstalk, bad repeater, or defective DSX jacks.

00-BIT ERRORS and 25-VIOLATIONS

These errors typically indicate a local T1 span problem caused by a bad splice, water on the cable, crosstalk, or defective DSX jacks.

40-RX FREQ, Hz

The DS1 received frequency should be 1.544 MHz \pm 58 Hz or 208 Hz for older transmission equipment. If the frequency is out-of-specification, check the transmission equipment timing or the network synchronization.

41-RX LEVEL (dBdsx)

The received level should be +4 to -4 dBdsx at the terminated DSX-1 OUT jacks. Incorrect levels could be caused by a faulty T1 line card or poor cabling between the DSX jack and the equipment.

Yellow Alarm LED

The far end sends a Yellow Alarm to indicate that it is not receiving a T1 signal. Sectionalize the T1 equipment further.

All Ones LED

If ALL ONES, MULTIPAT, or BRIDGTAP is being used, the LED illuminates when the ALL ONES pattern is transmitted and received.

BRIDGTAP or MULTIPAT Testing

ALL RESULTS OK

No errors were detected with the MULTIPAT and BRIDGTAP test.

FAILED MULTIPAT PATTERNS

If 3 IN 24 failed, it indicates a bad repeater (timing circuit) or one side of span is open.

If ALL ONES failed, it indicates a bad repeater (power output).

If 1:7 failed, it indicates a bad repeater (timing circuit) or one side of span is open.

If QRSS failed, it indicates a faulty cable.

Errored Results — MULTIPAT Errors

When all or part of the patterns fails, it generally indicates a malfunctioning repeater, multiplexer, or DSX. To determine the possible cause, repeat the individual failed pattern while monitoring the RESULTS display. If errors immediately start accumulating, it is probably a cabling problem. If no errors occur for a few minutes, and then a burst of errors occurs, the problem is probably a bad repeater.

Errored Results — BRIDGTAP Errors

When the errors are grouped around a number of patterns it indicates that a bridge tap exists on the span. Sectionalize the span to isolate the bridge tap.

Table 1 describes the results interpretation when testing a span with the MULTIPAT and BRIDGTAP pattern sequences.

**Table 1
MULTIPAT and BRIDGTAP Test Results**

Test	Pass/ Fail	Errors Detected	Comments
MULTIPAT	Pass	No	No repeater problems. No bridge taps.
BRIDGTAP	Pass	No	
MULTIPAT	Pass	No	No repeater problems. Bridge taps on span, errors occur in groups around a number of patterns but do not affect MULTIPAT patterns.
BRIDGTAP	Fail	Yes	
MULTIPAT	Fail	Yes	Bridgetaps on span if errors occur in groups around a number of patterns, including the MULTIPAT patterns. Possible repeater problems if BRIDGTAP pattern errors not grouped.
BRIDGTAP	Fail	Yes	

Pulse Shape Testing

A pulse mask is a graphical representation of the guidelines or template that is placed on the pulse shape (see Figure 5). The pulse width, rise time, fall time, undershoot, and overshoot are indicated in Figure 5 as well as results in the SIGNAL category.

41-RX LEVEL (dBdsx)

The received level should be +4 to -4 dBdsx at terminated DSX-1 OUT jacks to measure the pulse shape. If the level is outside this range, the message *OUT OF RANGE* appears.

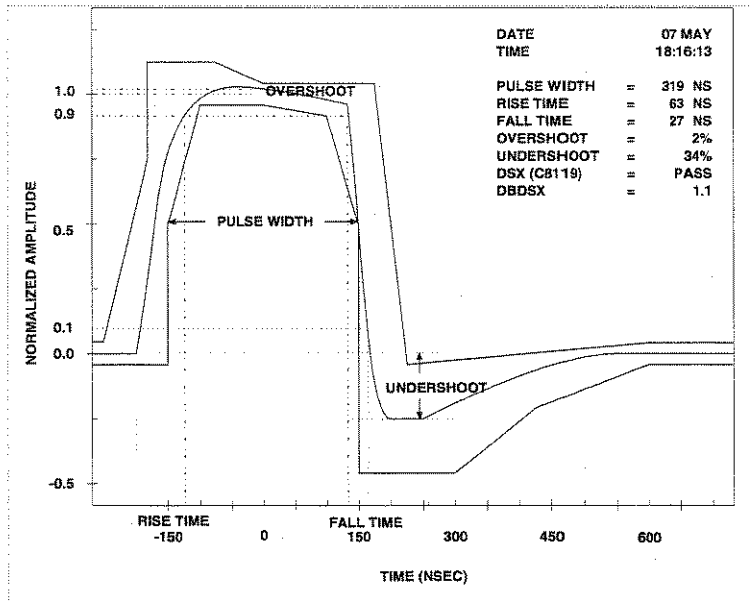

Figure 5
T1 Pulse Shape and Pulse Mask Specifications

44-PULSE SHAPE

This is a pass/fail response to whether the measured pulse shape falls within the selected pulse mask. When AUX PLS MASK is set to NONE, the message *NO MASK* appears.

45-PULSE WIDTH

This indicates the pulse width at the 50% point of the waveform (350 ns \pm 56 ns for DSX (CB119) or 356 ns \pm 56 ns for NI (ANSI)).

46-RISE TIME

This indicates the rise time of the leading edge between the 10% and 90% points of the waveform (less than 140 ns for DSX (CB119) or less than 152 ns for NI (ANSI)).

47-FALL TIME

This indicates the fall time of the trailing edge between the 10% and 90% points of the waveform (less than 117 ns for DSX (CB119) or less than 125 ns for NI (ANSI)).

TESTING T1 NETWORKS

APPLICATIONS

48-UNDERSHOOT

The undershoot is the amount of the trailing edge that falls below the zero point of the waveform (less than 45% of the normalized pulse for both DSX (CB119) and NI (ANSI)).

49-OVERSHOOT

The overshoot is the amount of the leading edge that rises above the 100% point of the waveform (less than 15% of the normalized pulse for DSX (CB119) or less than 20% of the normalized pulse for NI (ANSI)).

Pulse Shape LED

When either pulse mask is selected, this LED illuminates when the pulse shape exceeds the pulse mask specifications. When AUXPLS MASK is set to NONE, the Pulse Shape LED is disabled.

Jitter Spectral Analysis Testing (T-BERD 211 only)

41-RX LEVEL (dBdsx)

The received level should be +4 to -4 dBdsx at the terminated DSX-1 OUT jacks to measure the jitter. Levels outside this range cause the message *OUT OF RANGE* to appear in the jitter results.

88-SA P/F

Check this result to determine if the spectral content of each frequency band is within the selected jitter mask specification. Refer to Table 2 to determine which test results appear when configuring the jitter auxiliary functions.

PASS appears when the wideband jitter is less than 5.0 UI and highband jitter is less than 0.1 UI. The signal level is within prescribed limits.

FAILED appears when the wideband jitter is greater than 5.0 UI and highband jitter is greater than 0.1 UI. The signal level is within prescribed limits.

OUT OF RANGE appears when the signal level is outside prescribed limits.

89-SA FREQ (auto scrolling) and 90-SA FREQ (manual scrolling)

If any frequency band exceeds the jitter mask when the error event occurs, then jitter is the likely cause of the errors. This conclusion can be confirmed by taking several spectral analysis samples when no errors are present, and comparing them with the error event samples.

If the Jitter LED illuminates, but none of the frequency bands indicate jitter above 100% of the selected jitter mask, with no error events, then the errors may be caused by an in-phase summing of many jitter frequencies. Again, spectral analysis samples where errors are present should be taken to correlate the high jitter and low jitter measurements.

Table 2
Spectral Analysis Results and Auxiliary Functions

Results	Displayed Information	Auxiliary Function	Selection
88-SAP/F 89-SAFREQ 90-SAFREQ	N/A UNAVAILABLE (not shown)	AUX JIT S/A AUX JIT MASK	OFF NONE
88-SAP/F 89-SAFREQ 90-SAFREQ	N/A Frequencies and UI Frequencies and UI	AUX JIT S/A AUX JIT MASK	ON NONE
88-SAP/F 89-SAFREQ 90-SAFREQ	Pass/Fail/Unavailable Frequencies and % Mask Frequencies and % Mask	AUX JIT S/A AUX JIT MASK	ON Mask
88-SAP/F 89-SAFREQ 90-SAFREQ	UNAVAILABLE UNAVAILABLE (not shown)	AUX JIT S/A AUX JIT MASK	OFF Mask

Jitter LED

When the Jitter Spectral Analysis Option is enabled and a jitter mask is selected, the LED illuminates when the jitter spectral response exceeds 100% of the selected jitter mask. When the Jitter Spectral Analysis Option is enabled but a jitter mask is not selected, the LED is disabled.

10. Printout generation

If a hard copy record of the test results is desired, connect a printer to the T-BERD 209A/211 and produce printouts in accordance with *Basic Setups, Procedure 1*.

Print Pulse Shape or Jitter Spectral Analysis Graph

1. **MODE switch**
Select the AUX mode.
2. **PATTERN switch**
Select the AUX GRAPH function.

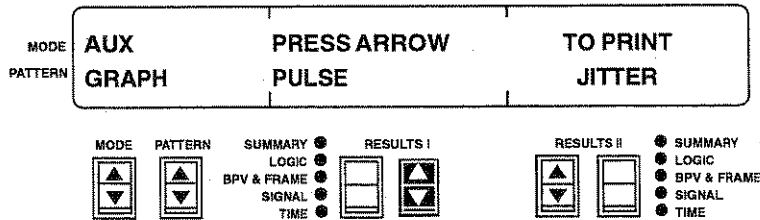

3. **RESULTS switches**
Press the **RESULTS I Results** switch to generate a pulse shape graph (see Figure 6). When AUX PLS MASK is set to NONE, no mask appears on the pulse shape printout.

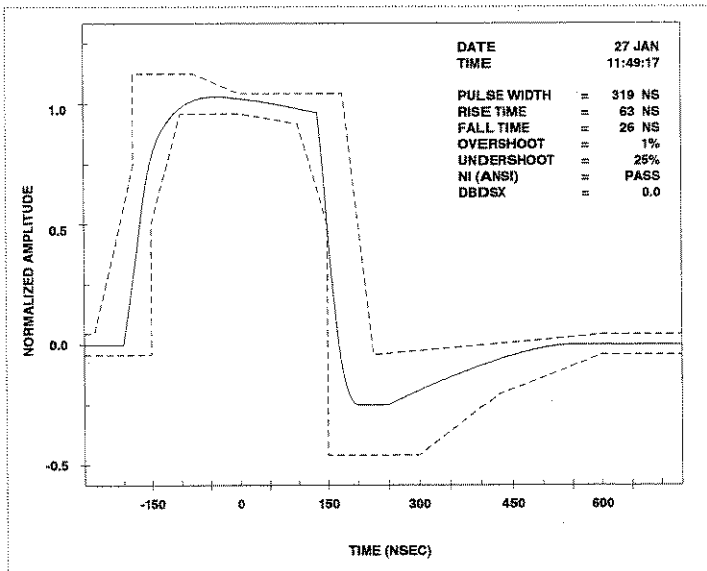

Figure 6
T1 Pulse Shape Graph

Press the **RESULTS II Results** switch to generate a jitter versus frequency graph (see Figure 7).

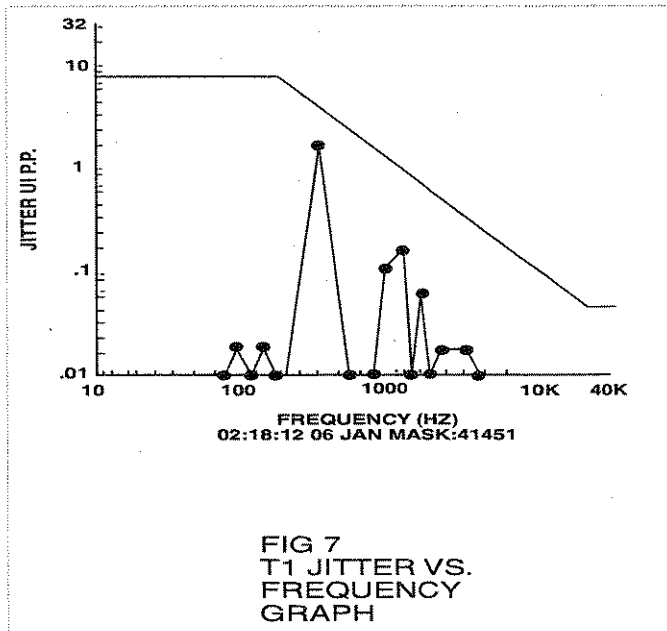
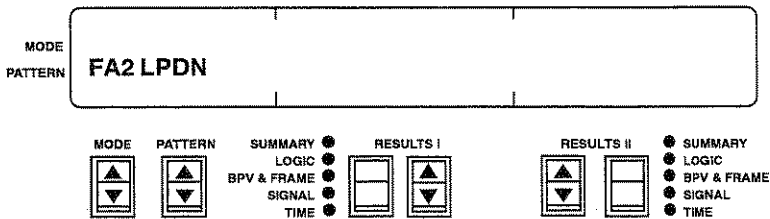

Figure 7
T1 Jitter vs. Frequency Graph

Disconnect the T-BERD 209A/211

LOOP DOWN switch

Press this switch to send the loop-down code. The switch and Loop Down LEDs illuminate until the loopback is released. A loop-down code message appears in the display.



TESTING T1 NETWORKS

APPLICATIONS

2. **Circuit disconnect**

Remove the cables from the DSX-1 OUT jack and DSX-1 IN jack. Then, remove the cables from the RECEIVE and TRANSMIT jacks.

6. LOOPBACK TESTING AT MID-SPAN *T-BERD T1 Repeater Extender Required*

This application assumes that a test at the central office revealed a circuit problem. This application sectionalizes the span to isolate the cause of the problem. The following steps connect the T-BERD 209A/211 to the T1 circuit at a span repeater location using a T-BERD T1 Repeater Extender. Refer to the *T-BERD T1 Repeater Extender Model 41157 Operating Manual* for more detailed configurations.

T-BERD Repeater Extender Test Setup

1. **Remove repeater**

Remove the desired repeater from the repeater housing unit and insert the repeater into the T-BERD Repeater Extender.

CAUTION: Removing the repeater disables the T1 span line.

2. **Configure the T-BERD T1 Repeater Extender switches:**

TEST	T1
TRANSMIT	TX SIDE 1 (if testing toward customer premises) TX SIDE 2 (if testing toward the central office)
SIGNAL PATH	THRU
CURRENT PATH	THRU

3. **Insert T-BERD Repeater Extender**

Insert the T-BERD Repeater Extender into the desired repeater slot.

CAUTION: High voltage may be encountered at the T1 Repeater Extender TESTING jacks when used on a working span. *To prevent electrical shock*, always plug test cables into test sets before connecting to the TESTING jacks. Always remove test cables from the TESTING jacks before removing them from the test set.

T-BERD 209A/211 Test Setup

1. Configure the T-BERD 209A/211 switches:

MODE	Scroll to the appropriate T1 network framing format.
PATTERN	Scroll to the appropriate test pattern.
TIMING	INT.
TEST	CONT.
CODE	AMI or B8ZS, as appropriate.
RECEIVE INPUT	BRIDGE.
TRANSMIT OUTPUT	0dB(DSX).
AUX LP CODE	IN-BAND—CSU, FAC1, FAC2, FAC3, or PGM, as appropriate. OUT-OF-BAND—LINE, PAYLOAD, or NETWORK, as appropriate.
AUX ESF LOOP	If ESF or FT1 ESF mode, ESF LOOP CODE—INBAND or OUT OFBAND, as desired.
AUX ERR SEL	BPV/LOGIC — SINGLE ERROR.
AUX PLS MASK	PULSE SELECT — DSX (CB119) or NI (ANSI), as appropriate.

2. T1 circuit connection

If testing toward the central office, connect a cable between the T-BERD 209A/211 RECEIVE jack and the T-BERD Repeater Extender SIDE 1 IN jack. Then, connect a cable from the T-BERD 209A/211 TRANSMIT jack to the T-BERD Repeater Extender TRANSMIT jack (see Figure 8). Skip to Step 4.

NOTE: When testing toward the central office, a hard loop must be established at the DSX-1 patch panel or equivalent location to establish the loopback.

If testing toward the customer premises, connect a cable between the T-BERD 209A/211 RECEIVE jack and the T-BERD Repeater Extender SIDE 2 IN jack. Then, connect a cable from the T-BERD 209A/211 TRANSMIT jack to the T-BERD Repeater Extender TRANSMIT jack (see Figure 9).

TESTING T1 NETWORKS
APPLICATIONS

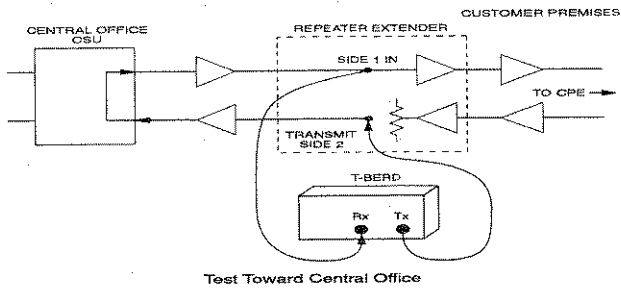

Figure 8
Mid-Span Testing Toward Central Office

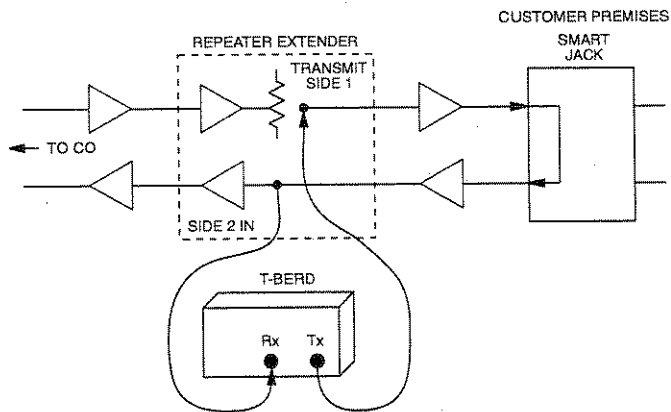
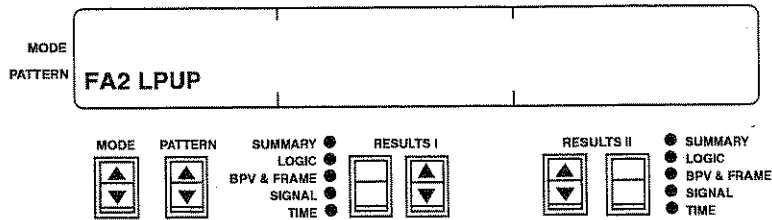

Figure 9
Mid-Span Testing Toward Customer Premises

3. **LOOP UP switch**

Press this switch to send the loop-up code. The switch LED illuminates until the loop code is detected. A loop-up code message appears in the display. The test restarts when the loopback is established.



4. **Status LEDs**

When the loopback is established, these LEDs should illuminate: T1 Pulses, Pattern Sync, Frame Sync, and B8ZS (if applicable).

5. **RESULTS I Category switch**

Select the SUMMARY category.

6. **LOGIC ERROR INSERT switch**

Press the switch five times to verify that the logic errors are received and the T1 circuit is looped back.

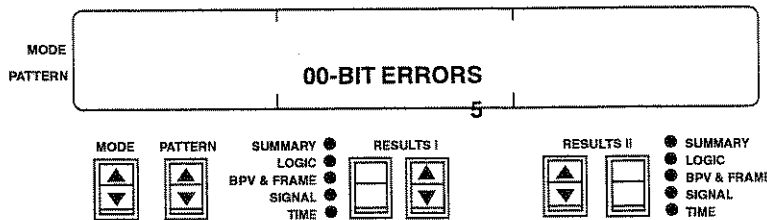

If the loopback is not established, the bit errors do not appear in the display. The failed loopback could be the NIU/CSU is not operating correctly, the line from you to the NIU/CSU is bad, or the transmitted loop code is incorrect.

7. **Press the RESTART switch**

8. **RESULTS I switches**

Check SUMMARY category. If errors are not detected, *ALL RESULTS OK* appears. If errors are detected, scroll through the SUMMARY category for specific errors. Check the other categories as required.

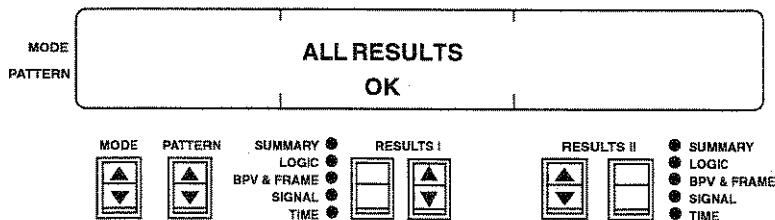

9. **Results interpretation**

00-BIT ERRORS only

Check the span before the DSX-1 by isolating sections and testing.

25-VIOLATIONS

These errors typically indicate a local T1 span problem caused by a bad splice, water on the cable, crosstalk, bad repeater, or defective DSX jacks.

00-BIT ERRORS and 25-VIOLATIONS

These errors typically indicate a local T1 span problem caused by a bad splice, water on the cable, crosstalk, or defective DSX jacks.

30-FRM ERRORS and 32-CRC ERRORS (ESF framing only)

These errors typically indicate a span line problem between you and the last piece of transmission equipment that framed the signal.

40-RX FREQ, Hz

The DS1 received frequency should be 1.544 MHz \pm 58 Hz or 208 Hz for older transmission equipment. If the frequency is out-of-specification, check the transmission equipment timing or the network synchronization.

41-RX LEVEL (dBdsx)

When testing at a mid-span repeater, if the signal level is

TESTING T1 NETWORKS

APPLICATIONS

correct at the input of the repeater, move the cable from the SIDE 1 (or 2) IN jack to the SIDE 1 (or 2) OUT jack. If the signal level is wrong at the output of the repeater, the problem could be the repeater itself or a ground/short on the span just beyond the repeater. A TDR test of the span would help determine the location of the fault.

If the signal level is correct at the output of the repeater, this portion of the span and this half of the repeater is operating correctly. Repeat the loopback test in the opposite direction.

The received level should be +4 to -4 dBdsx at the terminated DSX-1 OUT jacks. Incorrect levels could be caused by a faulty T1 line card or poor cabling between the DSX jack and the equipment.

Yellow Alarm LED

The far end sends a Yellow Alarm to indicate that it is not receiving a T1 signal. Sectionalize the T1 equipment further.

All Ones LED

If ALL ONES, MULTIPAT, or BRIDGTAP is being used, this LED illuminates when the ALL ONES pattern is transmitted and received.

Disconnect the T-BERD 209A/211

1. LOOP DOWN switch

Press this switch to send the loop-down code. The switch and Loop Down LEDs illuminate until the loopback is released. A loop-down code message appears in the display.

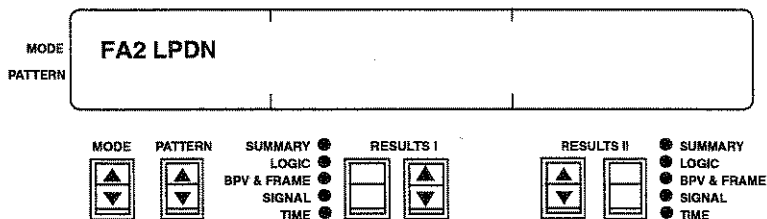

2. Circuit disconnect

Remove the cables from the T-BERD Repeater Extender jacks. Then, remove the cables from the RECEIVE and TRANSMIT jacks.

7. EMULATING A CSU AT CUSTOMER PREMISES

Requires Two Test Sets

- * Verify the span installation.
- * Terminate the T1 line and loop simplex current.
- * Measure simplex current and T1 level.
- * Auto-respond to T1 loop codes.
- * Functionally replace an NIU/CSU.

Emulating T-BERD 209A/211 Test Setup

1. Configure the T-BERD 209A/211 switches:

MODE	Scroll to AUTO mode.
PATTERN	Scroll to the appropriate test pattern.
TIMING	INT.
TEST	CONT.
CODE	AMI or B8ZS, as appropriate.
RECEIVE INPUT	TERM.
AUX LP CODE	IN-BAND—CSU, FAC1, FAC2, FAC3, or PGM, as appropriate. OUT-OF-BAND—LINE or NETWORK, as appropriate.
AUX ESF LOOP	If ESF mode, ESF LOOP CODE — IN BAND or OUT OF BAND, as desired.
AUX RESPONSE	RESPONSE—AUTORESPONSE.

2. Central office repeater power supply

Disconnect the office repeater power supply from the span being tested. Then disconnect the CSU from the span line at the NIU.

WARNING: High voltage may be encountered when disconnecting the office repeater power supply.

3. Transmit and receive connections

Connect a cable from the T-BERD 209A/211 RECEIVE jack to the NIU output. Connect a cable from the T-BERD 209A/211 TRANSMIT jack to the NIU input (see Figure 10).

WARNING: When one T-BERD 209A/211 connector is attached to a powered span line, the line voltage is also present on the associated T-BERD 209A/211 connections. Therefore, do not use or touch the other connections.

TESTING T1 NETWORKS
APPLICATIONS

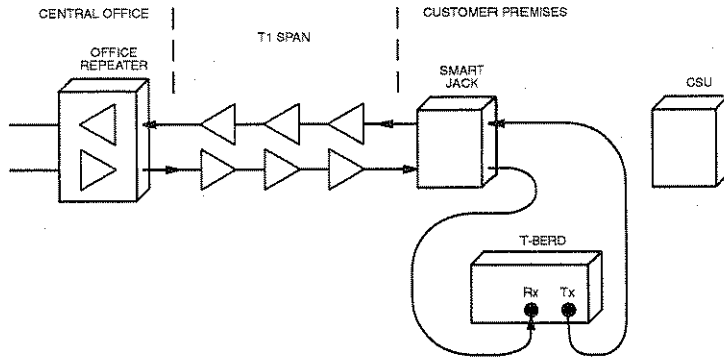

Figure 10
Emulating a CSU at the Customer Premises

4. **Central office repeater power supply**
Connect the office repeater power supply to the span being tested.
5. **RESULTS switches**
Select the SIGNAL category for both RESULTS windows. Scroll to the 41-RX LEVEL result in the RESULTS I window and the 50-SPX CURRENT result in the RESULTS II window. Verify the simplex current is within the expected range.

MODE PATTERN	41-RX LEVEL -15.0 dBdsx	50-SPX CURRENT 60 mA
-----------------	-----------------------------------	--------------------------------

MODE <input type="checkbox"/> PATTERN <input type="checkbox"/> <input type="checkbox"/> <input type="checkbox"/> <input type="checkbox"/> <input type="checkbox"/>	SUMMARY ● LOGIC ● BPV & FRAME ● SIGNAL ● TIME ●	RESULTS I <input type="checkbox"/> <input type="checkbox"/> <input type="checkbox"/> <input type="checkbox"/>	RESULTS II <input type="checkbox"/> <input type="checkbox"/> <input type="checkbox"/> <input type="checkbox"/>	SUMMARY ● LOGIC ● BPV & FRAME ● SIGNAL ● TIME ●
--------------------------------------------------------------------------------------------------------------------------------------------------------------------------	-------------------------------------------------------------	------------------------------------------------------------------------------------------------------------------	-------------------------------------------------------------------------------------------------------------------	-------------------------------------------------------------

6. **TRANSMIT OUTPUT switch**
Select an output level of 0 dBdsx if the receive level is -15 dBdsx or less, -7.5 dBdsx if the receive level is -14 to -8 dBdsx, or -15 dBdsx if the receive level is -7.5 dBdsx and above.

Central Office Test Set Test Setup

1. **Configure the Central Office test set**

Prepare the test set to transmit the loop code that matches the settings of the T-BERD 209A/211 auxiliary functions.

NOTE: The patterns must be matched to perform bit error measurements.

2. **Send CSU loop-up code from central office**

The T-BERD 209A/211 responds by establishing an AUTOLLB mode. This internally loops the receiver to the transmitter. The Loop Up LED illuminates when the loop-up code is received. The test restarts when the loopback is established.

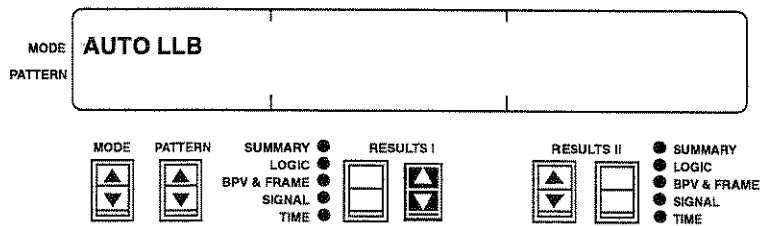

If AUTO LLB does not appear, check that the AUXRESPONSE function is set to AUTO RESPONSE or verify the AUX LP CODE function is set to the correct loop code. Also verify the central office setup.

3. **Status LEDs verification**

The loopback is successfully established if the T1 Pulses, Pattern Sync (if applicable), Frame Sync, and B8ZS (if applicable) LEDs illuminate.

4. **RESULTS I switches**

Check SUMMARY category. If errors are not detected, *ALL RESULTS OK* appears. If errors are detected, scroll through the SUMMARY category for specific errors. Check the other categories as required.

5. **Results interpretation**

25-VIOLATIONS

These errors typically indicate a local T1 span problem caused by a bad splice, water on the cable, crosstalk, or defective DSX jacks.

30-FRM ERRORS and 32-CRC ERRORS (ESF framing only)

These errors typically indicate a span line problem between you and the last piece of transmission equipment that framed the signal.

50-SPX CURRENT

Depending on the type of office repeater used, the simplex current should read approximately 60, 100, or 140 mA.

Yellow Alarm LED

The far end sends a Yellow Alarm to indicate that it is not receiving a T1 signal.

All Ones LED

If MULTIPAT or BRIDGTAP is being used, the LED will illuminate when the All Ones pattern is transmitted and received.

Disconnect the T-BERD 209A/211

1. **Send CSU loop-down code from the central office**

The T-BERD 209A/211 responds by releasing the AUTO LLB mode. The Loop Down LED illuminates when the loop-down code is received. This internally disconnects the receiver from the transmitter. Disconnect the T-BERD 209A/211 from the span.

2. **Central office repeater power supply**

Disconnect the office repeater power supply from the span being tested.

WARNING: High voltage may be encountered when disconnecting the office repeater power supply.

TESTING T1 NETWORKS

APPLICATIONS

3. **Disconnect the T-BERD 209A/211**
Disconnect the T-BERD 209A/211 from the NIU. Reconnect the CSU to the span line at the NIU.
4. **Central office repeater power supply**
Connect the office repeater power supply to the span being tested.

TESTING T1 NETWORKS
APPLICATIONS

8. TDR TESTING

TDR Option Required

- Test cable pair for shorts, opens, bridge taps, etc.

1. Cable pair preparation

Remove all known T1 impairments (bridge taps, coils, etc.).

Open both ends of the cable pair. On repeatered spans, remove the repeaters at either end of the span to be tested.

NOTE: The TDR cannot look past hard opens or shorts. Multiple faults on a cable pair reduce the effectiveness of the TDR. Therefore, as faults are located, they should be repaired and the line retested.

2. Configure the T-BERD 209A/211 switches:

MODE	Scroll to TDR mode.
PATTERN	Scroll to the TDR SETUP menu.
RESULTS I Category	CABLE — Select appropriate cable type and gauge.
RESULTS I Results	PR. VEL — Scroll to desired value only if cable type is USER/22, USER/24, or USER/26.
RESULTS II Results	LENGTH — 1000, 3000, or 6500, as appropriate.
RESULTS II Category	REF or NO REF — Select REF only if a previous trace is available and a reference trace is desired.

3. T1 REF (TDR) jack

Connect a test cable between this jack and the cable pair (see Figure 11).

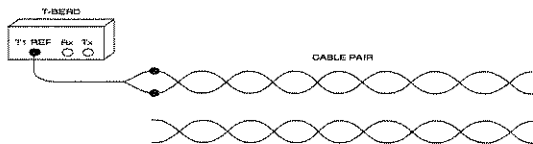

Figure 11
TDR Test Setup

TDR TESTING

APPLICATIONS

4. Press the **RESTART** switch to start the TDR test

5. **Test verification**

TESTING flashes in the PATTERN window and *RESULTS: NOT AVAILABLE* appears in the RESULTS I window. When test is completed, the fault and distance information appears in the RESULTS I window.

6. **Cable pair fault analysis**

If *FAULT 1: OPEN AT xxxx FEET* appears and the distance is the end of the cable, the cable is good. This ends the test.

If *FAULT 1: OPEN (or SHORT) AT xxxx FEET* appears and the distance is *not* the end of the cable, there is a short or open at the indicated distance. Clear the fault and repeat the procedure.

If *FAULT 1: NONE* appears, no fault is detected. Either the cable is too long for the distance being tested or it is terminated with no impedance mismatch.

If *FAULT 1: B-TAP AT xxxx FEET* appears, the cable has a bridge tap at the indicated distance. Clear the fault and repeat the procedure.

If *FAULT 1: UNREC AT xxxx FEET* appears, the cable has an unrecognized fault at the indicated distance. Use the TDR printout to identify the fault. Clear the fault and repeat the procedure.

7. **Generate a printout**

Go to *Print a Single Trace TDR Graph* to generate a single trace GRAPH. Go to *Print a Dual Trace TDR Graph* to generate a dual trace GRAPH. Go to *Print TDR Results and Setup* to generate the TDR results and setup printout.

Print a Single Trace TDR Graph

1. **PATTERN switch**

Select the TDR SETUP menu and verify NO REF is displayed.

TDR TESTING
APPLICATIONS

- PATTERN switch**
Select TDR RESULTS and verify PRINT GRAPH is displayed.
- RESULTS II Category switch**
Press this switch to PRINT GRAPH. A single trace graph is printed (see Figure 12).

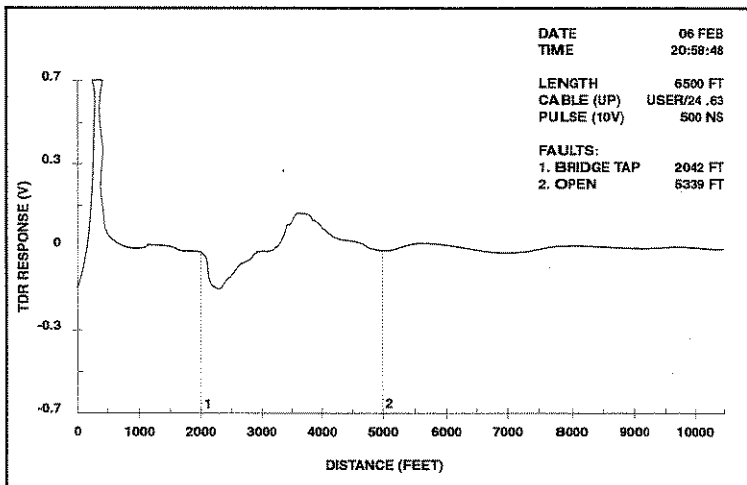

Figure 12
Single Trace TDR Graph

Print a Dual Trace TDR Graph

- PATTERN switch**
Select the TDR SETUP menu and verify NO REF is displayed.
- RESULTS II Category switch**
Press this switch to store the current trace and verify REF STORED appears.
- Select another cable pair and press the RESTART switch**
The second cable pair is tested and the results appear in the display.

TDR TESTING
APPLICATIONS

4. **RESULTS II Category switch**

When the TDR RESULTS appear, press this switch to select PRINT GRAPH. A dual trace graph is printed (see Figure 13).

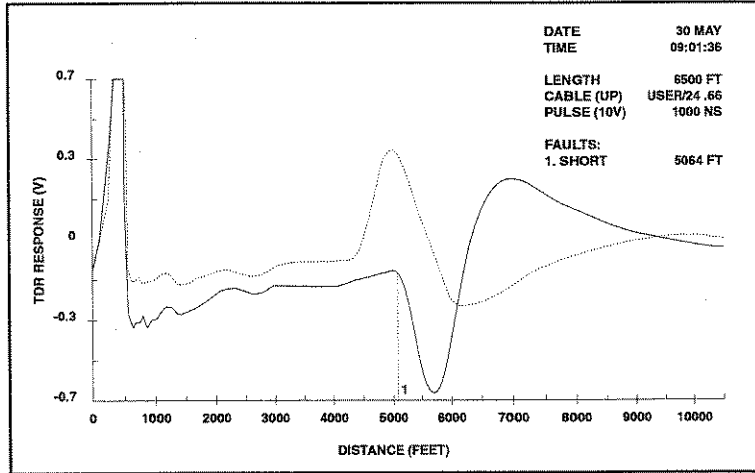

Figure 13
Dual Trace TDR Graph

Print TDR Results and Setup

1. **PRINT switch**

Press the RESULTS side to print the TDR RESULTS. Press the CONTROLS side to print the TDR SETUP (see Figure 14).

TDR CONTROLS PRINT	08:27:50	28 FEB
SETTINGS:		
LENGTH (FT)	AUTO	
CABLE (VP)	DEFAULT .66	
REFERENCE	NO	

TDR RESULTS PRINT	08:28:27	28 FEB
FAULTS:		
1. B-TAP at	2580 feet	
2. OPEN at	3640 feet	

Figure 14
TDR Controls and Results Printouts

9. MONITORING ESF PRMS

Enhanced ESF Option Required

- * Performs in-service error analysis on T1 ESF circuits.
- * Monitors ANSI T1.403 Performance Report Messages on T1 ESF circuits.

1. Configure the T-BERD 209A/211 switches:

MODE	Scroll to AUTO mode
TEST	CONT
CODE	AMI or B8ZS, as appropriate
RECEIVE INPUT	DSX-MON
AUX PRM	PRM TRANSMIT — OFF PRM RCVR — ON

2. RECEIVE jack

Connect a cable between this jack and the span-side DSX-1 MON jack (see Figure 15).

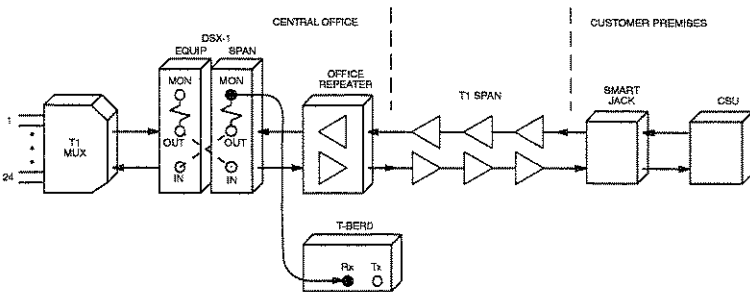

Figure 15
Monitoring T1 ESF Circuit PRMs

3. Press the RESTART switch

Verify received framing format (ESF) and pattern (or *live*) appear in lowercase characters in the MODE and PATTERN windows, respectively.

4. **Status LEDs**

The T1 Pulses, Frame Sync, and B8ZS (if applicable) LEDs should illuminate.

5. **RESULTS I switches**

Select the SUMMARY category. If *ALL RESULTS OK* is displayed and no Alarm LEDs are illuminated, the circuit is operating within specifications. If errors are detected, scroll through the SUMMARY category results for specific errors. Check the other categories as required.

6. **Results interpretation**

NOTE: If a tilde (~) precedes a test result, it indicates a PRM sync loss occurred after the test began.

17-FAR FRM ES

A count of the seconds in which one or more frame errors occurred. This result reports on the PRM Frame-Synchronization-Bit Error Event Bit (FE=1).

18-FAR FRM SES

A count of the seconds in which two or more frame errors occurred in less than 3 ms in the received signal at the far end. This result reports on the PRM Severely-Errored Framing Event Bit (SE=1).

19-FAR BPV SEC

A count of the seconds in which one or more BPVs occurred in the received signal at the far end. This result reports on the PRM Line-Code Violation Event Bit (LV=1).

20-FAR SLP SEC

A count of the seconds in which controlled slips occurred in the received signal at the far end. This result reports on the PRM Controlled-Slip Event Bit (SL=1).

21-FAR PRM SEC

A count of the total number of seconds, since test restart, in which a valid PRM was received.

22-FAR CRC ERR

A count of the minimum number of CRC errors reported in the following 22-FCRC results. This result reports on the PRM CRC Error Event Bits (G1 to G6) status. A ">" (greater than) preceding the count indicates that the Bins 2 through 6 are non-zero.

22-FCRC 1

A count of the seconds with only one CRC error reported in the received signal at the far end. This result reports on the first PRM CRC Error Event Bit (G1 = 1).

22-FCRC 2-5

A count of the seconds with 2 to 5 CRC errors reported in the received signal at the far end. This result reports on the second PRM CRC Error Event Bit (G2 = 1).

22-FCRC 6-10

A count of the seconds with 6 to 10 CRC errors reported in the received signal at the far end. This result reports on the third PRM CRC Error Event Bit (G3 = 1).

22-FCRC11-100

A count of the seconds with 10 to 100 CRC errors reported in the received signal at the far end. This result reports on the fourth PRM CRC Error Event Bit (G4 = 1).

22-FCRC101-319

A count of the seconds with 101 to 319 CRC errors reported in the received signal at the far end. This result reports on the fifth PRM CRC Error Event Bit (G5 = 1).

22-FCRC>319

A count of the seconds with 320 to 333 CRC errors reported in the received signal at the far end. This result reports on the sixth PRM CRC Error Event Bit (G6 = 1).

23-PAY SRC

Identifies the direction of the PRM according to the PRM Command/Response Bit (C/R) and the Payload Loopback Activated Bit (LB). In end-to-end applications, a customer generated PRM is indicated as CUST (C/R = 0 and LB = 0) and a carrier generated PRM is indicated as CARR (C/R = 1 and LB = 0) in the display. In payload loopback applications, the customer generated PRM is indicated as CUST LOOP (C/R = 0 and LB = 1) when the customer is looped back and the carrier generated PRM is indicated as CARR LOOP (C/R = 1 and LB = 1) when the carrier is looped back.

Disconnect the T-BERD 209A/211

1. Circuit disconnect

Remove the cable from the DSX-1 MON jack. Then, remove the cable from the RECEIVE jack.

10. MONITORING DS0 CHANNELS

T-BERD T1 Channel Monitor Option Required

- ◆ Displays channel signaling information for all 24 channels.
- ◆ Monitors a DS0 channel through speaker or VF output.

Connect T1 Channel Monitor to T-BERD 209A/211

1. T-BERD 209A/211 — turn power off

2. Connect coiled cable

Connect the T-BERD T1 Channel Monitor coiled cable to the T-BERD 209A/211 15-pin D connector.

T-BERD 209A/211 Test Setup

1. **Configure the T-BERD 209A/211 switches:**

POWER	ON
MODE	Scroll to AUTO mode
TEST	CONT
CODE	AMI or B8ZS, as appropriate
RECEIVE INPUT	DSX-MON

2. **RECEIVE jack**

Connect a cable between this jack and the span-side DSX-1 MON jack (see Figure 16).

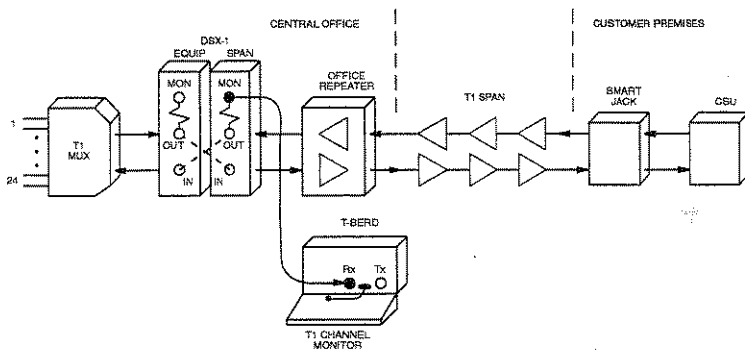

Figure 16
Monitoring T1 and DS0 Signals

ADVANCED TESTING

APPLICATIONS

3. **Press the RESTART switch**

Verify received framing format and pattern (or *live*) appear in lowercase characters in the MODE and PATTERN windows, respectively.

4. **Status LEDs**

The T1 Pulses, Frame Sync, and B8ZS (if applicable) LEDs should illuminate.

5. **RESULTS I switches**

Select the SUMMARY category. If *ALL RESULTS OK* is displayed and no Alarm LEDs are illuminated, the circuit is operating within specifications. If errors are detected, scroll through the SUMMARY category results for specific errors. Check the other categories as required.

6. **Results interpretation**

25-VIOLATIONS

These errors typically indicate a local T1 span problem caused by a bad splice, water on the cable, crosstalk, or defective DSX jacks.

30-FRM ERRORS and 32-CRC ERRORS (ESF framing only)

These errors typically indicate a span line problem between you and the last piece of transmission equipment that framed the signal.

40-RX FREQ, Hz

The DS1 received frequency should be 1.544 MHz \pm 58 Hz or 208 Hz for older transmission equipment. If the frequency is out-of-specification, check the transmission equipment timing or network synchronization.

41-RX LEVEL (dBdsx)

The received level should be -20 dBdsx \pm 3.5 dBdsx at resistor isolated DSX-1 MON jacks. Incorrect levels could be caused by a faulty T1 line card or poor cabling between the DSX jack and the equipment.

Yellow Alarm LED

This alarm LED indicates a problem in the transmission leg of the span.

T-BERD T1 Channel Monitor Test Setup

1. **Configure the T-BERD T1 Channel Monitor switches:**

FRAME FORMAT	Select the appropriate framing format
CHANNEL SELECT	Select the desired DS0 channel
VOLUME	Mid-level

2. **Results interpretation**

SIGNALING Display

Check the signaling for the selected DS0 channel. The AB signaling bits indicate the signaling status (on/off hook, idle, or ringing) for each DS0 channel for all framing formats. The CD signaling bits are only active with ESF framing.

Data Bit LEDs

Monitor the DS0 channel data bits for steady state conditions that can indicate alarms (i.e., Bit 2 is in a steady OFF state, Yellow Alarm; all bits are in a steady ON state, Idle signal).

LEVEL (dBm)

Measure the DS0 channel signal level. If the signal level exceeds +3 dBm, the Clipping LED illuminates. On a voice channel, the level varies as the speech pattern changes. It is common to see the Clipping LED flashing. On a data channel, the level should remain constant and the Clipping LED should not flash.

3. **VF OUT jack (optional)**

Connect a VF test set to the T-BERD T1 Channel Monitor to further analyze the VF signal of the selected DS0 channel.

4. **RS-232 connection (optional)**

Connect a test set (e.g., protocol analyzer) to the T-BERD T1 Channel Monitor to further analyze the ESF datalink, SLC datalink, or the DS0 channel data. Select the output with the **DATALINK/CHANNEL** switch.

Disconnect the T-BERD 209A/211

1. **Circuit disconnect**
Remove the cable from the DSX-1 MON jack. Then, remove the cable from the RECEIVE jack.
2. **T-BERD 209A/211 — turn power off**
3. **Disconnect coiled cable**
Disconnect the T-BERD T1 Channel Monitor coiled cable from the T-BERD 209A/211 15-pin D connector and return it to its storage location in the lid.

11. TESTING FRACTIONAL T1 NETWORKS

FT1 Option Required

- Conduct out-of-service testing of an FT1 network.
- Confirm that the contiguous or non-contiguous FT1 signal is properly received by the network equipment.

1. **Configure the T-BERD 209A/211 switches:**

MODE	Scroll to appropriate T1 framing format.
PATTERN	Scroll to desired test pattern.
TIMING	INT.
TEST	CONT.
CODE	AMI or B8ZS, as appropriate.
RECEIVE INPUT	TERM.
TRANSMIT OUTPUT	0dB(DSX).
AUX LP CODE	IN-BAND — CSU, FAC1, FAC2, FAC3, or PGM, as appropriate. OUT-OF-BAND — LINE, PAYLOAD, or NETWORK, as appropriate.
AUX ESF LOOP	If FT1 ESF mode, ESF LOOP CODE — IN BAND or OUT OF BAND, as desired.
AUX ERR SEL	BPV/LOGIC — SINGLE ERROR.

2. **T1 circuit connection**

Connect a cable from the RECEIVE jack to the span-side DSX-1 OUT jack. Connect a cable from the TRANSMIT jack to the span-side DSX-1 IN jack (see Figure 17).

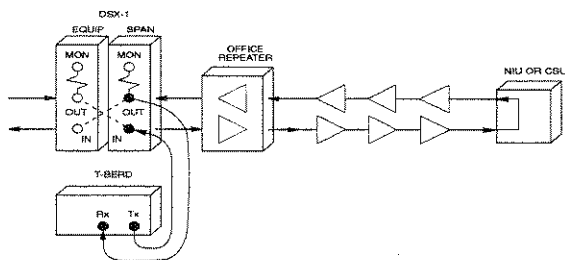
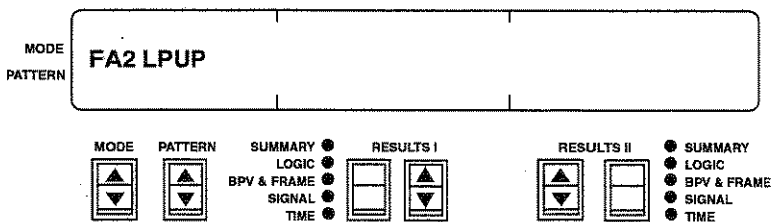

Figure 17
FT1 Circuit Testing

3. **LOOP UP switch**

Press this switch to send the loop-up code. The switch LED illuminates until the loop code is detected. A loop-up code message appears in the display. The test restarts when the loopback is established.



4. **Status LEDs**

The T1 Pulses, Frame Sync, Pattern Sync, and B8ZS (if applicable) LEDs should illuminate.

5. **RESULTS I Category switch**

Select the SUMMARY category.

6. **LOGIC ERROR INSERT switch**

Press this switch five times to verify the logic errors are received and the T1 circuit is looped back. The 00-BIT ERRORS result should appear in the RESULTS I window showing 5 bit errors.

If the loopback is not established, the bit errors do not appear in the display. The failed loopback could indicate the NIU/CSU is not operating correctly, the line from you to the NIU/CSU is bad, or the transmitted loop code is incorrect.

7. **Press the RESTART switch**

Fractional T1 Test Setup

1. **Configure the T-BERD 209A/211 switches:**

- | | |
|----------------------|-------------------------------------------------------------------------------------------------------|
| MODE | Scroll to FT1 D4 or FT1 ESF, as appropriate. |
| PATTERN | Select the desired FT1 test pattern (63, 511, or 2047). |
| AUX FT1 CHAN | Enter the desired contiguous or non-contiguous channels |
| AUX FT1 SETUP | IDLE CODE — Set the eight-digit idle code, as desired
CHAN RATE — 64 X N or 56 X N, as appropriate |

2. **Press the RESTART switch**

3. **Status LEDs**

The T1 Pulses, Frame Sync, Pattern Sync, and B8ZS (if applicable) LEDs should illuminate.

4. **RESULTS I switches**

Select the SUMMARY category. If *ALL RESULTS OK* is displayed and no Alarm LEDs are illuminated, the circuit is operating within specifications. If errors are detected, scroll through the SUMMARY category results for specific errors. Check the other categories as required.

Fractional T1 Results

1. Results interpretation

25-VIOLATIONS

These errors typically indicate a local T1 span problem caused by a bad splice, water on the cable, crosstalk, or defective DSX jacks.

30-FRM ERRORS and 32-CRC ERRORS (ESF framing only)

These errors typically indicate a span line problem between you and the last piece of transmission equipment that framed the signal.

40-RX FREQ, Hz

The DS1 received frequency should be 1.544 MHz \pm 58 Hz or 208 Hz for older transmission equipment. If the frequency is out-of-specification, check the transmission equipment timing or network synchronization.

41-RX LEVEL (dBdsx)

The received level should be The received level should be +4 to -4 dBdsx at the terminated DSX-1 OUT jacks. Incorrect levels could be caused by a faulty T1 line card or poor cabling between the DSX jack and the equipment.

Yellow Alarm LED

This alarm LED indicates a problem in the transmission leg of the span.

Disconnect the T-BERD 209A/211

1. LOOP DOWN switch

Press this switch to send the loop-down code. The switch and Loop Down LEDs illuminate until the loopback is released. A loop-down code message appears in the display.

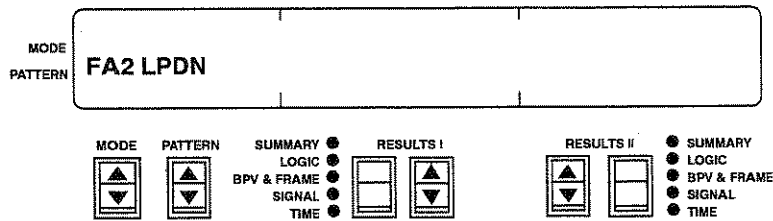

2. Circuit disconnect

Remove the cables from the DSX-1 OUT jack and DSX-1 IN jack. Then, remove the cables from the RECEIVE and TRANSMIT jacks.

12. REMOTE TESTING WITH AN NIU/PERFORMANCE MONITOR

Enhanced ESF Option Required

- * Retrieve ESF circuit performance data from the NIU/Performance Monitor.
- * Clear ESF circuit performance data from the NIU/Performance Monitor memory.
- * Set the NIU/Performance Monitor date and time.

1. Configure the T-BERD 209A/211 switches:

RECEIVE INPUT TERM.
 TRANSMIT OUTPUT 0dB(DSX).

2. **T1 circuit connection**

Connect a cable from the RECEIVE jack to the span-side DSX-1 OUT jack. Connect a cable from the TRANSMIT jack to the span-side DSX-1 IN jack (see Figure 18).

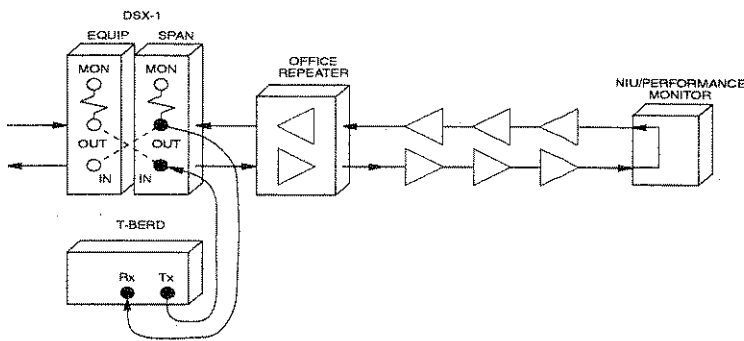

Figure 18
NIU/Performance Monitor Testing

SMARTNIU Test Setup

1. **Configure the T-BERD 209A/211 switches:**

MODE	Scroll to the SMARTNIU mode.
PATTERN	Select RESULTS.

2. **Press the RESTART switch**

The T-BERD 209A/211 automatically transmits the loop code to loop up the NIU/Performance Monitor. When the loopback is established, the T-BERD 209A/211 automatically starts retrieving the performance data from the NIU/Performance Monitor.

The message *QUERY IN PROGRESS* appears in the RESULTS I window. The message *### OF nnn RECEIVED* appears in the RESULTS II window, where *###* is the number of the messages retrieved, and *nnn* is the number of messages stored in the NIU/Performance Monitor.

SMARTNIU Results

1. Query function verification

When the Query function stops, one of the following messages is displayed. A Query failure message indicates the Query function failed because of loss of signal, loss of frame, excessive retransmission of a message, timeout of a response to a query message, or loss of power. If a QUERY FAILURE message is displayed, check the test setup connections and repeat the test.

QUERY COMPLETE/ALL DATA OK — indicates Query function is complete with no errors reported.

QUERY COMPLETE/ERRORS DETECTED — indicates Query function is complete with one or more errors reported.

QUERY FAILURE/NO DATA AVAILABLE — indicates the Query function failed with no data retrieved.

QUERY FAILURE/PARTIAL DATA OK — indicates the Query function failed with some messages retrieved. The retrieved data reported no errors.

QUERY FAILURE/ERRORS DETECTED — indicates the Query function failed with some messages retrieved. The retrieved data included error messages.

2. Printer connection

Connect a cable from the RS-232 interface on the side panel to a PR-40A, or equivalent printer, in accordance with Basic Setups Procedure 1 Generating Printouts.

3. Generate a printout

If the data retrieval was successful and error messages were detected, press the **PRINT** switch **RESULTS** position to generate a Results printout that includes a SMART NIU results printout. The SMART NIU results printout lists the NIU/Performance Monitor messages retrieved in periodic reports of both A-Z (CO to NIU) and Z-A (customer premises to NIU) directional results. These periodic reports include a Current Hour Report, 23 History Hour Reports (Hour 01 through Hour 23), a Current Day Report, and 7 History Day Reports (Day 01 through Day 07).

2. **Activate the Set Clock function**

Press the **RESULTS I Results** switch to activate the Set Clock feature. The Set Clock process takes approximately ten seconds.

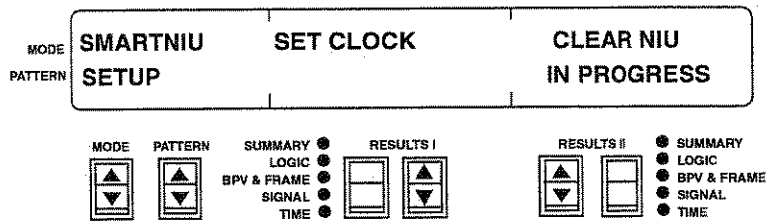

3. **Results Interpretation**

Once the Set Clock process is complete, the display reports the status of the Set Clock function as either *CLOCK SET* or *SET CLOCK FAILED*. If a *SET CLOCK FAILED* message is displayed, check the test setup connections and repeat the test. If it fails again, check the bit error rate in the LOGIC category.

Disconnect the T-BERD 209A/211

1. **Circuit disconnect**

Remove the cables from the DSX-1 OUT jack and DSX-1 IN jack. Then, remove the cables from the RECEIVE and TRANSMIT jacks.

13. TESTING INTELLIGENT REPEATER SPANS

Advanced BERT Option Required

- Sectionalize addressable repeater spans by transmitting appropriate loop codes from the central office.

1. **Configure the T-BERD 209A/211 switches:**

MODE	Scroll to a T1 framed format (T1 D4, T1 ESF, or T1 SLC).
PATTERN	Scroll to desired test pattern.
TIMING	INT.
TEST	CONT.
CODE	AMI or B8ZS, as appropriate (if pattern is BRIDGTAP, set to AMI).
RECEIVE INPUT	TERM.
TRANSMIT OUTPUT	0dB(DSX).
AUX ESF LOOP	If ESF mode, ESF LOOP CODE — IN BAND or OUT OF BAND, as desired.
AUX ERR SEL	BPV/LOGIC — SINGLE ERROR.

2. **T1 circuit connection**

Connect a cable from the RECEIVE jack to the span-side DSX-1 OUT jack. Connect a cable from the TRANSMIT jack to the span-side DSX-1 IN jack (see Figure 19).

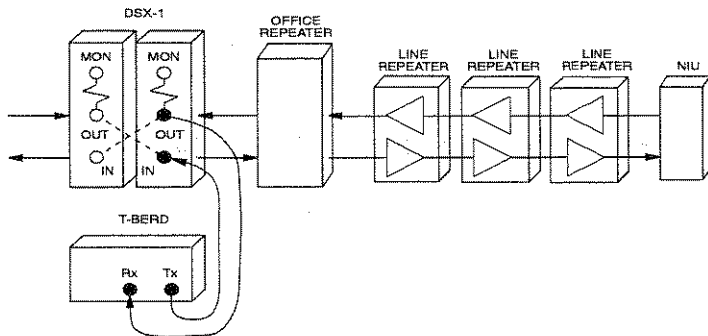

Figure 19
Intelligent Repeater Span Test Setup

ADVANCED TESTING

APPLICATIONS

- 3. **MODE switch**
Select the AUX mode.
- 4. **PATTERN switch**
Select AUX LP CODE to set the appropriate arming code (e.g., WESTELL ARM or TELTREND ARM). If the span is composed of XEL repeaters, go to the Addressable Repeater Span Sectionalization procedure.
- 5. **MODE switch**
Press this switch once to exit the auxiliary function.
- 6. **LOOP UP switch**
Press this switch to send the arming/NIU loop-up code. The switch LED illuminates until the loop code is detected. A loop-up code message appears in the PATTERN window. This arms the span's addressable repeaters and provides a loopback at the NIU.

If the switch LED remains illuminated, the span problem may be preventing the loop code from reaching the NIU or returning to the T-BERD 209A/211. Go to the *Addressable Repeater Span Sectionalization* procedure and attempt to loop up the mid-span addressable repeater.

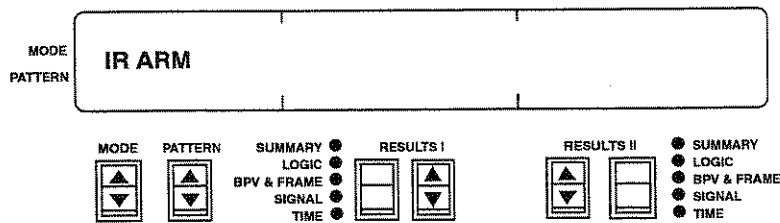

- 7. **Status LEDs**
The T1 Pulses, Pattern Sync, Frame Sync, and B8ZS (if applicable) LEDs should illuminate.

8. RESULTS I switches

Check the SUMMARY category. If *ALL RESULTS OK* appears, no further testing of the span is necessary. Go to the *Disconnect the T-BERD 209A/211* procedure.

If errors are detected, scroll through the SUMMARY category for specific errors. Check the other categories as required. Record the types of errors to determine the symptoms of the span problem.

9. Symptoms identification**25-VIOLATIONS**

These errors typically indicate a local T1 span problem caused by a bad splice, water on the cable, crosstalk, or defective DSX jacks.

30-FRM ERRORS and 32-CRC ERRORS (ESF framing only)

These errors typically indicate a span line problem between you and the last piece of transmission equipment that framed the signal.

25-VIOLATIONS, 30-FRM ERRORS, and 32-CRC ERRORS (ESF framing only)

These errors typically indicate a local T1 span problem caused by a bad splice, water on the cable, crosstalk, or defective DSX jacks.

40-RX FREQ, Hz

The DS1 received frequency should be 1.544 MHz \pm 58 Hz or 208 Hz for older transmission equipment. If the frequency is out-of-specification, check the transmission equipment timing or the network synchronization.

41-RX LEVEL (dBdsx)

The received level should be +4 to -4 dBdsx at the terminated DSX-1 OUT jacks. Incorrect levels could be caused by a faulty T1 line card or poor cabling between the DSX jack and the equipment.

Yellow Alarm LED

This alarm LED indicates a problem in the transmission leg of the span.

Addressable Repeater Span Sectionalization

1. **MODE switch**
Select the AUX mode.
2. **PATTERN switch**
Select AUX LP CODE to set the appropriate addressable repeater type and address to match the mid-span addressable repeater.

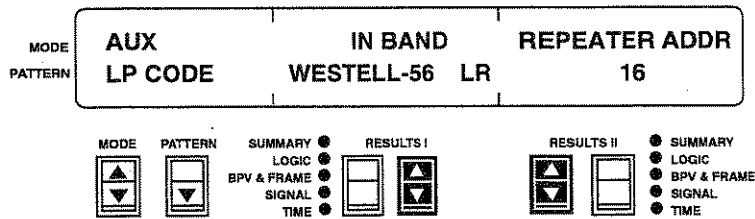

3. **MODE switch**
Press this switch once to exit the auxiliary function.
4. **LOOP UP switch**
Press this switch to send the addressable repeater loop-up code to the mid-span repeater. The switch LED illuminates until the loop code is detected. This loops back the signal at the mid-span addressable repeater.

If the switch LED remains illuminated, the span problem may be preventing the loop code from reaching the mid-span addressable repeater or from returning to the T-BERD 209A/211. Go to Step 8 and select a repeater closer to the CO.
5. **Status LEDs verification**
The T1 Pulses, Pattern Sync, Frame Sync, and B8ZS (if applicable) LEDs should illuminate.
6. **Results interpretation**
Check the SUMMARY category. If the identified symptoms are detected, the problem is between the Central Office (CO) and the looped-back mid-span repeater.

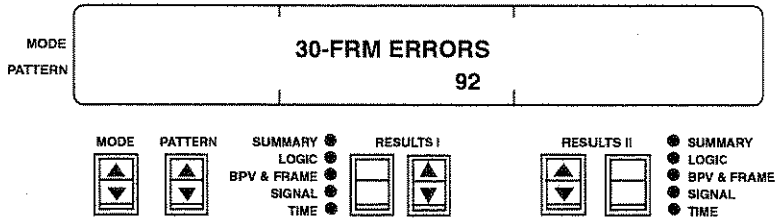

If the T-BERD 209A/211 was unable to loop back the signal at the addressed repeater, the span problem is probably between the CO and the addressed repeater. The span problem could be blocking the loop codes.

If the message *ALL RESULTS OK* is displayed and no Alarm LEDs are illuminated, the problem is between the looped-back mid-span repeater and the customer premises.

7. **LOOP DOWN switch**

Press this switch to send the addressable repeater loop-down code to the mid-span repeater.

8. **Determine new addressable repeater address**

Select a new addressable repeater to be looped back based on the results in Step 6.

9. **MODE, PATTERN, and RESULTS switches**

Select the AUX LP CODE function. Set the REPEATER ADDR parameter to match the selected addressable repeater.

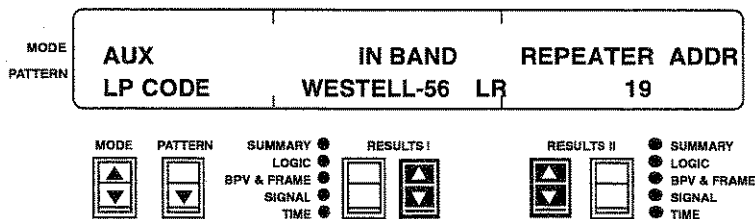

10. **MODE switch**

Press this switch once to exit the auxiliary function.

11. LOOP UP switch

Press this switch to send the addressable repeater loop-up code to the selected repeater. The switch LED illuminates until the loop code is detected.

If the T-BERD 209A/211 was unable to loop back the signal at the addressed repeater, the span problem is probably between the CO and the addressed repeater. The span problem could be blocking the loop codes. Go to Step 13.

12. Results interpretation

If the looped-back repeater is closer to the CO and errors are still detected, the problem is between the Central Office (CO) and the looped-back repeater. If the looped-back repeater is closer to the CO and no errors are detected, the problem is between the two looped-back repeaters.

If the looped-back repeater is closer to the customer premises and errors are detected, the problem is between the two looped-back repeaters. If the looped-back repeater is closer to the customer premises and no errors are detected, the problem is between the looped-back repeater and the customer premises.

13. Repeat steps until problem is isolated

Repeat Steps 7 through 12 until the problem's location has been isolated between two or three repeaters. Now the problem's exact location can be determined by accessing only one or two repeater housings.

14. LOOP DOWN switch

Press this switch to loop down the addressable repeater.

Disconnect the T-BERD 209A/211

1. **MODE, PATTERN, and RESULTS switches**
Select AUX LP CODE to set the appropriate arming/disarming code.

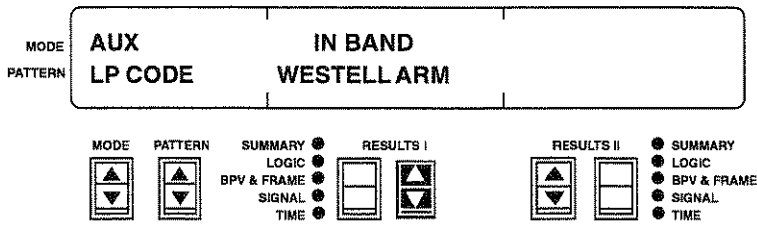

2. **MODE switch**
Exit the auxiliary function.
3. **LOOP DOWN switch**
Press this switch to send the disarming/NIU loop-down code. The switch LED illuminates until the loopback is released. A loop-down code message appears in the display. Disconnect the T-BERD 209A/211 from the span.

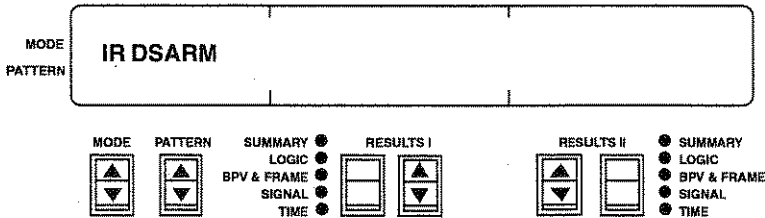

ADVANCED TESTING

APPLICATIONS

14. TESTING FROM THE MDF

T-BERD Repeater Power Supply Required

- Power a T1 span line from the main distribution frame (MDF).
- Measure the current and voltage across a T1 span line.
- Provide the T-BERD 209A/211 access to the T1 span line from the MDF.

WARNING: It is important that the T-BERD Repeater Power Supply be operated by qualified technicians in accordance with the safety warnings and instructions printed on the front panel of the unit. Failure to do so could result in serious personal injury. Carefully read the safety information in Section 4 of the *T-BERD 209A/211 Reference Manual* before operating the T-BERD Repeater Power Supply.

T-BERD Repeater Power Supply Test Setup

WARNING: Do not apply power to the T-BERD Repeater Power Supply until instructed to do so. When power is applied to the T-BERD Repeater Power Supply there is a 350 VDC potential across the terminals, which can cause personal injury.

1. **Connect Mainframe Interconnect Cable**
Connect the T-BERD Repeater Power Supply Mainframe Interconnect Cable to the T-BERD 209A/211 15-pin D connector (see Figure 20).

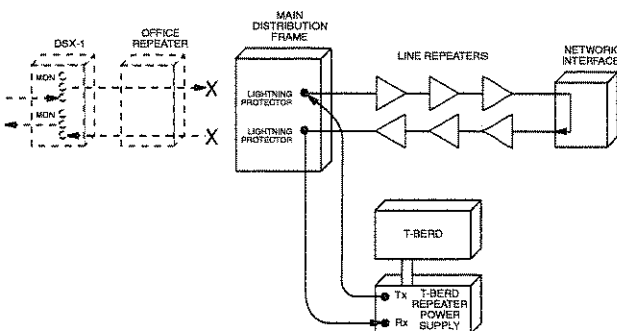

Figure 20
Test Setup at the MDF

TESTING NEWLY INSTALLED T1 SPANS

APPLICATIONS

2. **Connect the dual WECO 310 or bantam test cords**
Insert dual WECO 310 or dual bantam test cords into the appropriate transmit and receive jacks on the T-BERD Repeater Power Supply front panel. Connections to the central office distribution frame should be made with a W4CJ test access cord for 303-type protection blocks or a W4BR test access cord for 302-type and 308-type protection blocks.
3. **Remove MDF lightning protectors**
Remove the MDF lightning protectors from the cable pairs being tested. Insert the transmit and receive cord connectors from the T-BERD Repeater Power Supply into the positions vacated by the lightning protectors (see Figure 20).
4. **60 mA 100 mA 140 mA switch**
Select the appropriate current level. The appropriate current setting is determined by the type of repeaters in the circuit being tested. The typical selection is 60 mA.
5. **T-BERD Repeater Power Supply AC power**
Connect a power cord from the T-BERD Repeater Power Supply into a 120 VAC power outlet. Make sure the **AC Power** switch is turned OFF.
6. **Apply power to the T-BERD Repeater Power Supply**
When power is applied to the T-BERD Repeater Power Supply, the red High Voltage LED flashes. This indicates that current is passing through the T-BERD Repeater Power Supply. If the red High Voltage LED continues to flash, the current path can not be established, check for an open circuit or other possible wiring fault.

When the circuit current path is established, the red High Voltage LED remains on continuously. The VOLTAGE and CURRENT displays reflect the current and voltage on the circuit.

To determine if the measured voltage is correct for the span being tested, calculate the expected span line voltage drop with the following formula. The V_{rpt} and V_{cable} can be found in Tables 3 and 4 respectively.

TESTING NEWLY INSTALLED T1 SPANS
APPLICATIONS

$$\text{Total } V_{\text{drop}} = (\# \text{ repeaters} \times V_{\text{rpt}}) + (V_{\text{cable}} \times \text{kft of cable})$$

- If the transmit and receive connections are reversed, the measured voltage will be much less than the expected voltage. Typically, V_{rpt} , when current is reversed, is between 1 and 2 volts.
- Allow for any extra voltage drop required for office repeaters and NIUs. The typical voltage drop for transmission devices is 8 to 16 volts each.
- Allow for additional CSU voltage drops of 14 to 24 volts.

Table 3
Typical Repeater Voltage Drop

Repeater Type	Voltage Drop/Repeater (V_{rpt})		
	60 mA	100 mA	140 mA
238 A/B	7.0	7.1	7.2
239 A/B	7.6	8.2	8.7
239E	8.4	9.6	10.7

Table 4
Typical Cable Gauge Voltage Drop

Cable Gauge	Voltage Drop/kft (V_{cable})		
	60 mA	100 mA	140 mA
26	2.7	4.5	6.3
24	1.7	2.8	4.0
22	1.1	1.8	2.6
19	0.5	0.8	1.2

TESTING NEWLY INSTALLED T1 SPANS
APPLICATIONS

T-BERD 209A/211 Test Setup

1. **Configure the T-BERD 209A/211 switches:**

POWER	ON.
MODE	Scroll to the appropriate T1 network framing format.
PATTERN	Scroll to desired test pattern.
TIMING	INT.
TEST	CONT.
CODE	AMI or B8ZS, as appropriate (if pattern is BRIDGTAP, set to AMI).
RECEIVE INPUT	TERM.
TRANSMIT OUTPUT	Select appropriate level such that the sum of the signal level and line build-out is between -15 dBdsx and -22.5 dBdsx (typical setting of -7.5 dB(DSX)).
AUX LP CODE	IN-BAND—CSU, FAC1, FAC2, FAC3, or PGM, as appropriate. OUT-OF-BAND—LINE, PAYLOAD, or NETWORK, as appropriate.
AUX ESF LOOP	If ESF mode, ESF LOOP CODE—IN BAND or OUT OF BAND, as desired.
AUX ERR SEL	BPV/LOGIC—SINGLE ERROR.

2. **T1 circuit connection**

Connect a cable from the RECEIVE jack to the span-side DSX-1 OUT jack. Connect a cable from the TRANSMIT jack to the span-side DSX-1 IN jack (see Figure 20).

3. **LOOP UP switch**

Press this switch to send the loop-up code. The switch LED illuminates until the loop code is detected. A loop-up code message appears in the display. The test restarts when the loopback is established.

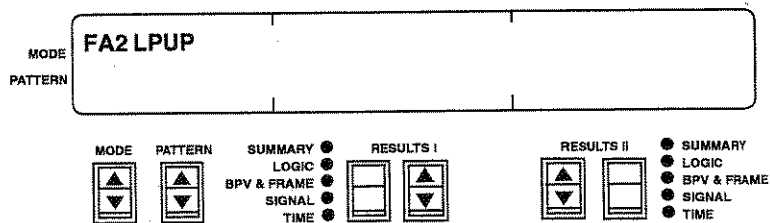

TESTING NEWLY INSTALLED T1 SPANS
APPLICATIONS

4. **Status LEDs**

When the loopback is established, the T1 Pulses, Pattern Sync, Frame Sync, and B8ZS (if applicable) LEDs should illuminate.

5. **RESULTS I Category switch**

Select the SUMMARY category.

6. **LOGIC ERROR INSERT switch**

Press the switch five times to verify that the logic errors are received and the T1 circuit is looped back.

If the loopback is not established, the bit errors do not appear in the display. The failed loopback could be the NIU/CSU not operating correctly, the line from you to the NIU/CSU is bad, or the transmitted loop code is incorrect.

7. **Press the RESTART switch**

8. **RESULTS I switches**

Check SUMMARY category. If errors are not detected, *ALL RESULTS OK* appears. If errors are detected, scroll through the SUMMARY category for specific errors. Check the other categories as required.

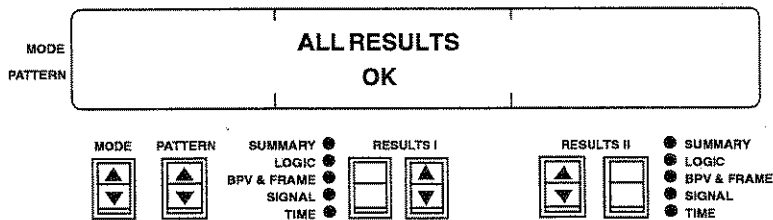

9. **Results interpretation**

25-VIOLATIONS only

These errors typically indicate a local T1 span problem caused by a bad splice, water on the cable, crosstalk, or defective DSX jacks.

30-FRM ERRORS and 32-CRC ERRORS (ESF framing only)

These errors typically indicate a span line problem between you and the last piece of transmission equipment that framed the signal.

TESTING NEWLY INSTALLED T1 SPANS

APPLICATIONS

25-VIOLATIONS, 30-FRM ERRORS, and 32-CRC ERRORS (ESF framing only)

These errors typically indicate a local T1 span problem caused by a bad splice, water on the cable, crosstalk, or defective DSX jacks.

40-RX FREQ, Hz

The DS1 received frequency should be $1.544\text{ MHz} \pm 58\text{ Hz}$ or 208 Hz for older transmission equipment. If the frequency is out-of-specification, check the transmission equipment timing or the network synchronization.

41-RX LEVEL (dBdsx)

The received level should be +4 to -4 dBdsx at the terminated DSX-1 OUT jacks. Incorrect levels could be caused by a faulty T1 line card or poor cabling between the DSX jack and the equipment.

NOTE: If the Loopback Connector is going to be used as a hard loopback at the MDF, the signal level must be -15 dBdsx or greater to support the loopback signal.

Yellow Alarm LED

This alarm LED indicates a problem in the transmission leg of the span.

Disconnect the Test Setup

3. LOOP DOWN switch

Press this switch to send the loop-down code. The switch and Loop Down LEDs illuminate until the loopback is released. A loop-down code message appears in the display. Disconnect the T-BERD 209A/211 from the span.

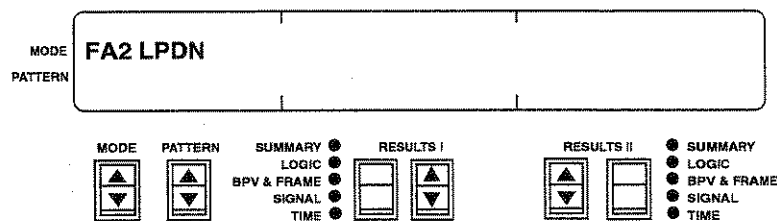

2. **T-BERD Repeater Power Supply AC power**

When you have completed testing the circuit, turn the T-BERD Repeater Power Supply **AC Power** switch OFF.

WARNING: Verify that power has been removed from the T-BERD Repeater Power Supply. Disconnecting the test cords from the T-BERD Repeater Power Supply or the MDF before removing power from the T-BERD Repeater Power Supply creates a 350 VDC potential across the terminals, which can cause personal injury.

3. **Disconnect from the MDF lightning protectors**

When the red High Voltage LED is no longer illuminated, remove the test cords from the distribution frame and replace the lightning protectors.

4. **Disconnect the dual WECO 310 or bantam test cords**

Remove the dual WECO 310 or dual bantam test cords from the T-BERD Repeater Power Supply jacks.

5. **T-BERD 209A/211 AC power**

Remove power from the T-BERD 209A/211.

6. **Disconnect Mainframe Interconnect Cable**

Disconnect the Mainframe Interconnect Cable from the T-BERD 209A/211 15-pin D connector.

15. TESTING FROM MID-SPAN

T-BERD Repeater Power Supply and T-BERD T1 Repeater Extender Required

- * Loopback the T1 span line at the MDF and test from mid-span.
- * Power a T1 span line from the MDF.

WARNING: It is important that the T-BERD Repeater Power Supply be operated by qualified technicians only in accordance with the safety warnings and instructions printed on the front panel of the unit. Failure to do so could result in serious personal injury. Carefully read the safety information in Section 4 of the *T-BERD 209A/211 Reference Manual* before operating the T-BERD Repeater Power Supply.

Main Distribution Frame Setup

1. **T-BERD Repeater Power Supply test setup**
Perform Steps 1 through 6 of the *T-BERD Repeater Power Supply Test Setup* in Application 14 to configure the T-BERD Repeater Power Supply at the MDF.
2. **T-BERD Repeater Power Supply AC Power switch**
Turn the AC power OFF.
3. **T-BERD Repeater Power Supply Mainframe Interconnect Cable**
Disconnect the Mainframe Interconnect Cable from the T-BERD 209A/211 15-pin D connector.
4. **T-BERD Repeater Power Supply Loopback Connector**
Connect the 15-pin D Loopback Connector to the Mainframe Interconnect Cable.
5. **T-BERD Repeater Power Supply AC Power switch**
Coordinate the setup with the mid-span technician before applying AC power. Apply power after the mid-span setup is configured.

WARNING: Notify the technician at the mid-span point when the span is powered. An unterminated cable pair can have a potential of 350 VDC across it, which can cause personal injury.

Test From Mid-Span

T-BERD Repeater Extender Test Setup

1. **Remove repeater**

Remove the desired repeater from the repeater housing unit and insert the repeater into the T-BERD Repeater Extender.

CAUTION: Removing the repeater disables the T1 span line.

2. **Configure the T-BERD T1 Repeater Extender switches:**

TEST	T1.
TRANSMIT	TX SIDE 2 (to test toward the central office).
SIGNAL PATH	THRU.
CURRENT PATH	THRU.

3. **Insert T-BERD Repeater Extender**

Insert the T-BERD Repeater Extender into the desired repeater slot.

CAUTION: High voltage may be encountered at the T1 Repeater Extender TESTING jacks when used on a powered span. *To prevent electrical shock*, always plug test cables into test sets before connecting to the TESTING jacks. Always remove test cables from the TESTING jacks before removing them from the test set.

T-BERD 209A/211 Test Setup

1. **Configure the T-BERD 209A/211 switches:**

MODE	Scroll to the appropriate T1 network framing format.
PATTERN	Scroll to the appropriate test pattern.
TIMING	INT.
TEST	CONT.
CODE	AMI or B8ZS, as appropriate.
RECEIVE INPUT	BRIDGE.
TRANSMIT OUTPUT	0dB(DSX).

TESTING NEWLY INSTALLED T1 SPANS APPLICATIONS

2. T1 circuit connection

Connect a cable between the T-BERD 209A/211 RECEIVE jack and the T-BERD Repeater Extender SIDE 1 IN jack. Then, connect a cable from the T-BERD 209A/211 TRANSMIT jack to the T-BERD Repeater Extender TRANSMIT jack (see Figure 21).

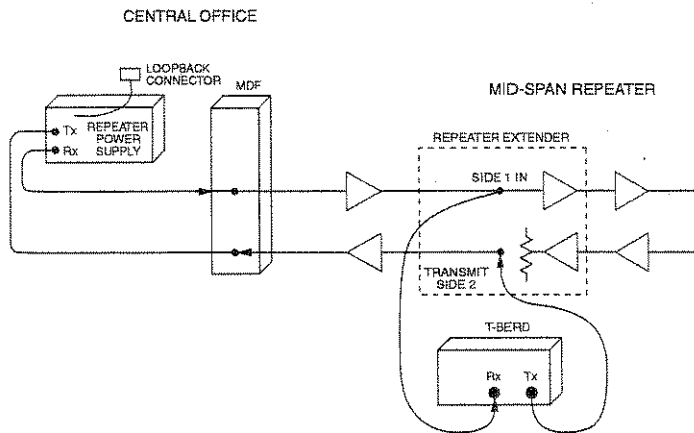

Figure 21
Testing From Mid-Span

3. Test T1 span

Transmit a test pattern or use MULTIPAT or BRIDGTAP to test the portion of span between the central office and the mid-span repeater. Refer to Application 6 for test results interpretation.

Disconnect Test Equipment

1. **T-BERD Repeater Power Supply**

Remove power from the T-BERD Repeater Power Supply first. When the red High Voltage LED is no longer illuminated, remove the test cords from the distribution frame and replace the lightning protectors.

WARNING: Verify power has been removed from the T-BERD Repeater Power Supply. Disconnecting the test cords from the T-BERD Repeater Power Supply or the MDF before removing power from the T-BERD Repeater Power Supply creates a 350 VDC potential across the terminals, which can cause personal injury.

2. **T-BERD 209A/211**

Disconnect the T-BERD 209A/211 from the span.

TESTING NEWLY INSTALLED T1 SPANS
APPLICATIONS

16. MONITORING DIGITAL LOOP CARRIER (DLC) SHELF OPERATION

T-BERD DLC Analyzer Option Required

- ⊛ Perform non-intrusive monitoring of the DLC shelf datalink and DS0 channels.
- ⊛ Monitor the datalink traffic between the Central Office Switch (COS) or Central Office Terminal (COT), and the Remote Terminal (RT) for major, minor, and power/miscellaneous alarms, as well as switch-to-protect and maintenance tests.
- ⊛ Monitor DS0 channel signaling in both directions and capture DTMF dialed digits.

Connect DLC Analyzer Option to T-BERD 209A/211

1. **Apply power to power source**
If the T-BERD 209A/211 is supplying power, turn power ON. If the external power supply is supplying power, plug external power supply into 110 VAC.
2. **Connect coiled cable**
Connect the T-BERD DLC Analyzer Option coiled cable to either the T-BERD 209A/211 15-pin D connector or external power supply.

T-BERD DLC Analyzer Option Test Setup

1. **Configure the T-BERD DLC Analyzer Option:**

FRAME	AUTO.
CODE	Set to appropriate coding.
RECEIVE INPUT	DSX-MON.
VOLUME	Set to mid-position.
CHANNEL/VF DROP	Select PRIMARY, SECONDARY, or BOTH.
CHANNEL/CHANNEL SCROLL	Select SEPARATE or BOTH.

DLC TESTING
APPLICATIONS

2. **PRIMARY RECEIVE jack**

Connect a cable between this jack and the Shelf A equipment-side DSX-1 MON jack (see Figure 22).

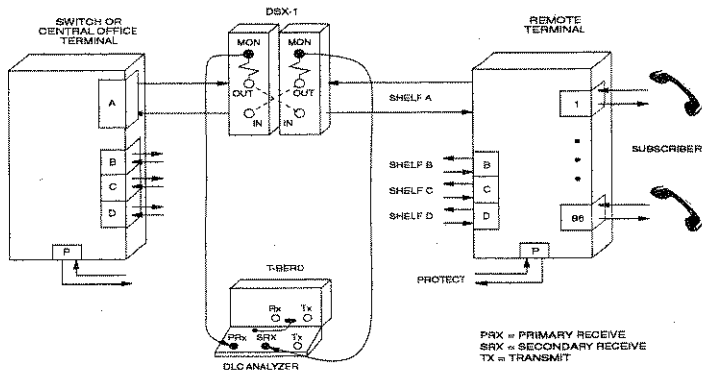

Figure 22
Monitoring DLC Shelf Operation

3. **SECONDARY RECEIVE jack**

Connect a cable between this jack and the Shelf A span-side DSX-1 MON jack (see Figure 22).

4. **Press the RESTART switch**

5. **FRAME/FORMAT window**

Verify the framing format is detected and recognized.

NOTE: When synchronizing to the SLC-96 framing in AUTO mode, the T-BERD DLC Analyzer Option automatically defaults to the SLC-M1 mode. The SLC-M2 mode must be selected manually with the **FRAME** switch.

6. **Status LEDs**

The T1 Pulses, Frame Sync, and B8ZS (if applicable) LEDs should illuminate. The Alarm LED may illuminate.

7. **RESULTS I switches**

Check the SUMMARY category. If errors or alarms are not detected, *ALL RESULTS OK* appears. If errors or alarms are detected, scroll through the SUMMARY category for specific errors or alarms. Check the other categories as required.

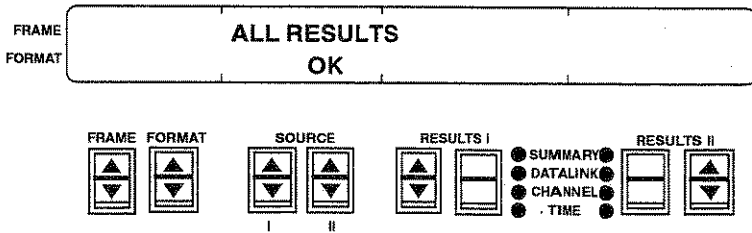

8. **Datalink results interpretation**

Flashing Messages — P/S DATALINK SYNC LOSS

This message indicates the T-BERD DLC Analyzer Option lost datalink synchronization. Probable cause would be a bad DL card. This message only appears in the SUMMARY category.

Alarm Messages — P/S MAJOR ALM, P/S MAJOR SHELF x, P/S ALARM SHELF x

These alarms indicate a service affecting fault on the indicated shelf. Possible causes include too high a BPV rate, loss of signal, and similar severe circuit problems. These messages also appear in the DATALINK category as a historical record of the indicated events.

Alarm Messages — P/S MINOR ALM

This alarm indicates a non-service affecting fault. This message also appears in the DATALINK category as a historical record of the indicated events.

Alarm Messages — P/S PWR/MISC

This alarm indicates an application-specific event has occurred (e.g., loss of power, door ajar, fire, etc.). This message also appears in the DATALINK category as a historical record of the indicated events.

Alarm Messages — P/S FE LOOP PROTECT, P/S FE LOOP SHELF x, and P/S SHELF x ON PROT

The SHELF x ON PROT alarm can be verified at the DLC Analyzer Option and the RT. The other alarms can only be verified at the RT or with a BERT test of the line. If the message is from the office to the RT, it means the office is holding a loop on the line at the RT. If the message is from the RT to the office, it means the RT never received the loop command. These messages also appear in the DATALINK category as a historical record of the indicated events.

Maintenance Test Messages — P/S MAINT HOOK/SEIZE, P/S MAINT PROCEED, and P/S MAINT TEST ALARM

These messages indicate the associated maintenance test condition is detected. Progress messages appear in lowercase in the SOURCE II display. These progress messages include, *hook/seize, proceed, succeed, test alarm* (means no response from the RT), *failed*, (means test alarm from RT). These message also appear in the DATALINK category as a historical record of the indicated events.

9. **T1 signal results interpretation**

P/S SIGNAL LOSS, P/S VIOLATION, P/S FRM ERROR, and P/S CRC ERROR (ESF only)

These errors typically indicate a local T1 span problem caused by a faulty repeater, span line noise, crosstalk, poor cabling, defective DSX jacks, or faulty multiplexer. Electrical noise, generated near the metallic span can also contribute to errors received at the instrument. These messages only appear in the SUMMARY category.

10. **PRIMARY CHANNEL or SECONDARY CHANNEL switch**

Press either switch to select a DS0 channel.

11. **DS0 channel results interpretation**

P/S VF LEVEL, P/S VF FREQ, P/S DATA BITS, and DTMF SEQ

Verify the VF signal level and frequency are within specifications. Verify a data bit is not stuck. Monitor the DTMF dialing sequences. The availability of these results is determined by the CHANNEL/VFDROP auxiliary function.

P/S TRAFFIC CHANNEL AB, P/S TRAFFIC CHANNEL ABCD, P/S TRAFFIC TIMESLOT AB, and P/S TS CHAN

For all framing formats except SLC-M2, monitor the channel signaling bits. For the SLC-M2 framing format, monitor the timeslot signaling and the timeslot channel assignments.

12. **VOLUME control**

Adjust the control to monitor the selected DS0 channel(s) through the speaker. Verify the setting of the CHANNEL/VF DROP auxiliary function.

13. **VF OUT jack**

Connect a TIMS test set to the T-BERD DLC Analyzer Option to perform additional testing and analysis on the selected DS0 channel. Verify the CHANNEL/VFDROP auxiliary function is set to PRIMARY or SECONDARY, not BOTH.

17. TESTING SHELF A RT OPERATION

T-BERD DLC Analyzer Option Required

- ✦ Verify switch-to-protection line capabilities of Shelf A at the Remote Terminal (RT).
- ✦ Verify the far-end loopback capability at the Shelf A RT.

Connect DLC Analyzer Option to T-BERD 209A/211

1. **Configure the T-BERD 209A/211 switches:**

MODE	Scroll to T1 TLB mode.
TEST	CONT.
CODE	AMI or B8ZS, as appropriate.
RECEIVE INPUT	TERM.

2. **T-BERD 209A/211 — RECEIVE jack**

Connect a cable (1) from the T-BERD 209A/211 RECEIVE jack to the T-BERD DLC Analyzer Option TRANSMIT jack (see Figure 23).

3. **Connect coiled cable**

Connect the T-BERD DLC Analyzer Option coiled cable to the T-BERD 209A/211 15-pin D connector after applying power to the T-BERD 209A/211.

4. **T-BERD 209A/211 — INSERT switch**

Verify the switch LED is OFF before connecting the T-BERD DLC Analyzer Option to the circuit.

DLC TESTING
APPLICATIONS

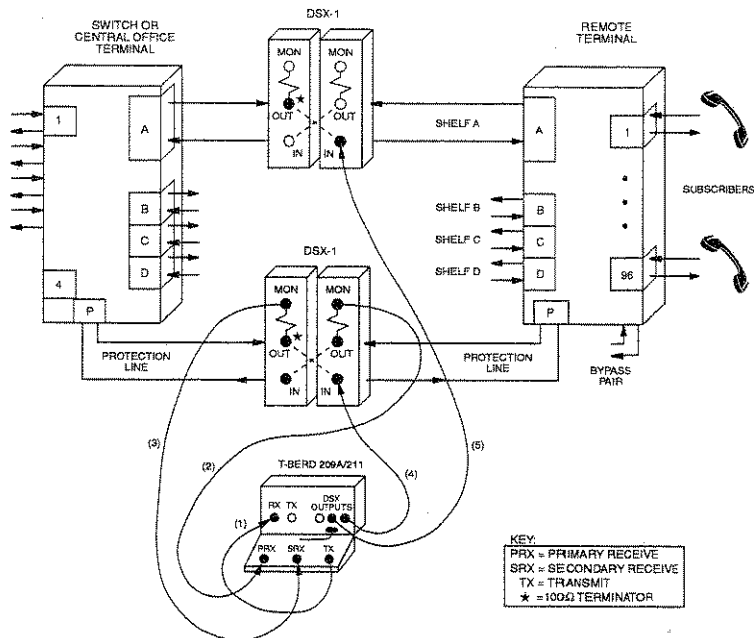

Figure 23
Testing Shelf A RT Operation

T-BERD DLC Analyzer Option Test Setup

1. **Configure the T-BERD DLC Analyzer Option:**

FRAME	SLC-M1 or SLC-M2.
FORMAT	DATLINK.
CODE	Set to appropriate coding.
RECEIVE INPUT	DSX-MON.
VOLUME	Set to mid-position.
TRANSMIT/LBO	Select 0.0 dB or -15.0 dB, as appropriate.
CHANNEL/CHANNEL SCROLL	Select SEPARATE or BOTH.

2. **Circuit connections**

If at the CO, connect cables as follows (see Figure 23):

Connect the first cable (2) from the PRIMARY RECEIVE jack to the T1 protection line span-side DSX-1 MON jack. Connect the second cable (3) from the SECONDARY RECEIVE jack to the Shelf A equipment-side DSX-1 MON jack. Connect a 100 Ω terminator into the T1 protection line equipment-side DSX-1 OUT jack.

If at the RT, connect three cables as follows:

Connect the first cable (2) from the PRIMARY RECEIVE jack to the T1 protection line equipment-side DSX-1 MON jack. Connect the second cable (3) from the SECONDARY RECEIVE jack to the T1 protection line span-side DSX-1 MON jack. Connect a 100 Ω terminator into the T1 protection line equipment-side DSX-1 OUT jack.

3. **T-BERD 209A/211 — DSX OUTPUTS jacks**

If at the CO, connect cables as follows (see Figure 23):

Connect a cable (4) from a DSX OUTPUT jack to the T1 protection line span-side DSX-1 IN jack. Connect a second cable (5) from a DSX OUTPUT jack to the Shelf A span-side DSX-1 IN jack. Connect a 100 Ω terminator into the Shelf A equipment-side DSX-1 OUT jack.

If at the RT, connect cables as follows:

Connect a cable (4) from a DSX OUTPUT jack to the T1 protection line equipment-side DSX-1 IN jack. Connect a second cable (5) from a DSX OUTPUT jack to the Shelf A equipment-side DSX-1 IN jack. Connect a 100Ω terminator into the Shelf A span-side DSX-1 OUT jack.

NOTE: You may notice a brief burst of errors in the T1 signal when the cable is connected to the T1 protection line DSX-1 IN jack.

NOTE: Plugging the cable into Shelf A DSX-1 IN jack breaks the T1 line and causes a switch-to-protection sequence to occur. Therefore, all connections on the protect line should be in place before plugging into Shelf A. The switch-to-protection line messages should appear on the T-BERD DLC Analyzer Option.

4. **T-BERD DLC Analyzer Option — RESTART switch**

Clear the results and start the test.

5. **T-BERD DLC Analyzer Option — Status LEDs**

Both primary and secondary T1 Pulses, Frame Sync, and B8ZS (if applicable) LEDs should illuminate. The Alarms LED may illuminate.

6. **T-BERD DLC Analyzer Option — RESULTS switches**

Check the SUMMARY category. If errors or alarms are not detected, *ALL RESULTS OK* appears. If errors or alarms are detected, scroll through the SUMMARY category for specific errors or alarms. Check the other categories as required.

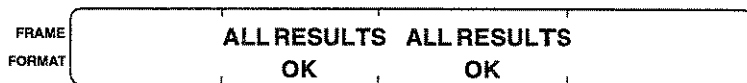

Verify Far-End Loopback Capability

1. **SOURCE I and II switches**
Set **SOURCE I** switch to FE LOOP and **SOURCE II** switch to SHELF A.

2. **INSERT switch**
Press this switch to send the FE LOOP command to the RT. The switch LED flashes for three seconds. During the three seconds of flashing, the FE LOOP command is temporarily inhibited, the instrument is reconfigured, and the T1 signal from the SECONDARY RECEIVE input is passed on to the TRANSMIT output unaffected. When the **INSERT** switch LED stops flashing and illuminates, the FE LOOP command is inserted into the T1 signal.

NOTE: When the FE LOOP command is transmitted, it is automatically preceded by a switch-to-protection line command to prevent an interruption of the selected shelf.

3. **Datalink results interpretation**
P/S SHELF A ON PROT
Both alarms indicate the office and the RT have switched Shelf A to the protection line successfully. If only the *P SHELF A ON PROT* message appears, only the RT has switched Shelf A to the protection line.

WARNING: If the *SW PROT FAILED* message appears, the switch-to-protection sequence failed, do not continue with the procedure. This message could indicate that another line is already on the protection line. Disconnect from the circuit in accordance with the Disconnect T-BERD DLC Analyzer Option from the Circuit procedure.

4. **Shelf A — 100 Ω terminator**
Unplug the terminator from DSX-1 OUT jack.

5. **Shelf A — Cable (5)**
Disconnect the cable from the Shelf A DSX-1 IN jack first. Then disconnect the cable from the T-BERD 209A/211.

6. **Connect T-BERD 209A/211 (2) to Shelf A**

Connect a cable from the T-BERD 209A/211 TRANSMIT jack to the DSX-1 IN jack. Connect another cable from the T-BERD 209A/211 RECEIVE jack to the DSX-1 OUT jack. Configure the T-BERD 209A/211 to perform a loopback test on the shelf and verify the far-end loop is successful (see Figure 24).

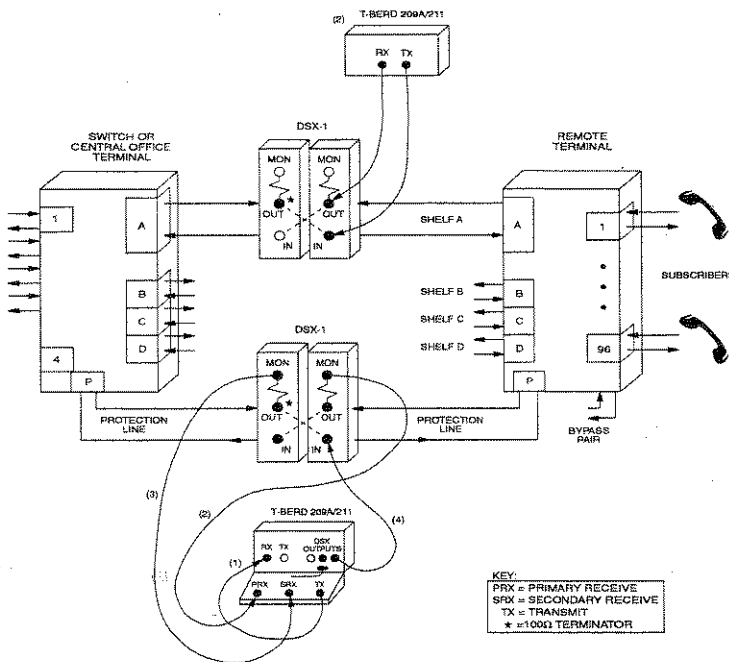

Figure 24
Testing Shelf A RT Operation

7. **Disconnect T-BERD 209A/211 (2) from Shelf A**

Disconnect the cables from the DSX-1 patch panel and the T-BERD 209A/211.

8. **T-BERD DLC Analyzer Option — INSERT switch**

Press this switch to stop sending the command to the RT. The switch LED goes out and Shelf A should be released from the far-end loopback.

Disconnect T-BERD DLC Analyzer Option from the Circuit

1. **T-BERD DLC Analyzer Option — INSERT switch**
Verify the switch LED is OFF before disconnecting the T-BERD DLC Analyzer Option from the circuit.
2. **Protection Line — 100 Ω terminator**
Unplug the terminator from DSX-1 OUT jack.
3. **Protection Line — Cable (4)**
Disconnect the cable from the protection line DSX-1 IN jack first. Then disconnect the cable from the T-BERD 209A/211.
4. **PRIMARY RECEIVE and SECONDARY RECEIVE jacks**
Disconnect the cables from the DSX-1 MON jacks, then the T-BERD DLC Analyzer Option.
5. **Disconnect Cable (1)**
Disconnect the cable from the T-BERD DLC Analyzer Option TRANSMIT jack and T-BERD 209A/211 RECEIVE INPUT jack.

18. TESTING RT DATALINK OPERATION

T-BERD DLC Analyzer Option Required

- Verify the major, minor, and power/miscellaneous alarm response capabilities of the remote terminal (RT).
- Verify the switch-to-protection response capability on Shelves B, C, and D.
- Verify the maintenance test sequence capability on Shelf A.

Connect DLC Analyzer Option to T-BERD 209A/211

1. **Apply power to power source**
If the T-BERD 209A/211 is supplying power, turn power ON.
If the external power supply is supplying power, plug external power supply into 110 VAC.
2. **Connect coiled cable**
Connect the T-BERD DLC Analyzer Option coiled cable to either the T-BERD 209A/211 15-pin D connector or external power supply after applying power to the power source.
3. **INSERT switch**
Verify the switch LED is OFF before connecting the T-BERD DLC Analyzer Option to the circuit.

T-BERD DLC Analyzer Option Test Setup

1. **Configure the T-BERD DLC Analyzer Option:**

FRAME	SLC-M1 or SLC-M2.
FORMAT	DATLINK.
CODE	Set to appropriate coding.
RECEIVE INPUT	DSX-MON.
VOLUME	Set to mid-position.
CHANNEL/VF DROP	Select PRIMARY, SECONDARY, or BOTH.
CHANNEL/CHANNEL SCROLL	Select SEPARATE or BOTH.
TRANSMIT/LBO	Select 0 dB if transmitting into the span or select -15.0 dB if transmitting into the equipment.

DLC TESTING
 APPLICATIONS

2. **Circuit connections**

If at the CO, connect three cables as follows (see Figure 25):

Connect the first cable from the PRIMARY RECEIVE jack to the Shelf A span-side DSX-1 MON jack. Connect the second cable from the SECONDARY RECEIVE jack to the Shelf A equipment-side DSX-1 MON jack. Connect the third cable from the TRANSMIT jack to the Shelf A span-side DSX-1 IN jack.

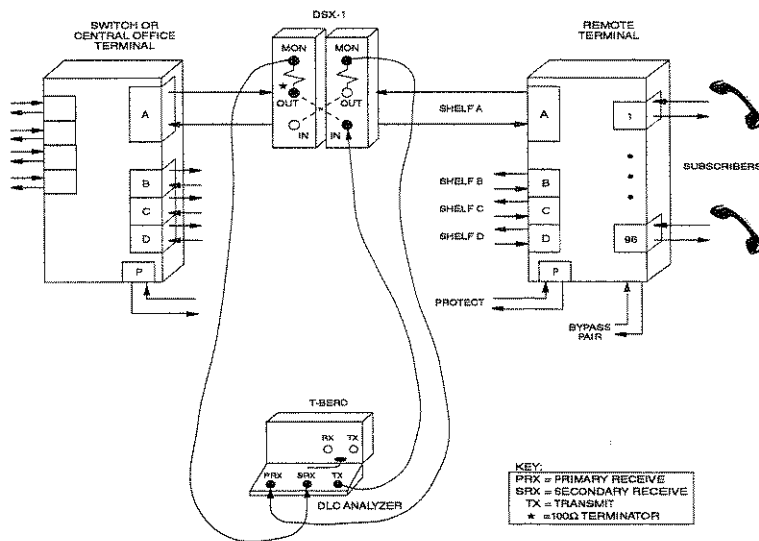

Figure 25
Testing Remote Terminal Datalink Operation

If at the RT, connect three cables as follows:

Connect the first cable from the PRIMARY RECEIVE jack to the Shelf A equipment-side DSX-1 MON jack. Connect the second cable from the SECONDARY RECEIVE jack to the Shelf A span-side DSX-1 MON jack. Connect the third cable from the TRANSMIT jack to the Shelf A equipment-side DSX-1 IN jack.

NOTE: You may notice a burst of errors in the T1 signal when the cable is connected to the DSX-1 IN jack. If persistent errors are detected after the cable is connected, verify the resistor isolation at the DSX-1. If improper resistor isolation is determined, plug a 100 Ω terminator into the appropriate DSX-1 OUT jack simultaneously with the cable from the TRANSMIT jack.

3. **Press the RESTART switch**

4. **Status LEDs**

Both primary and secondary T1 Pulses, Frame Sync, and B8ZS (if applicable) LEDs should illuminate. The Alarms LED may illuminate.

5. **RESULTS I switches**

Check the SUMMARY category. If errors or alarms are not detected, *ALL RESULTS OK* appears. If errors or alarms are detected, scroll through the SUMMARY category for specific errors or alarms. Check the other categories as required.

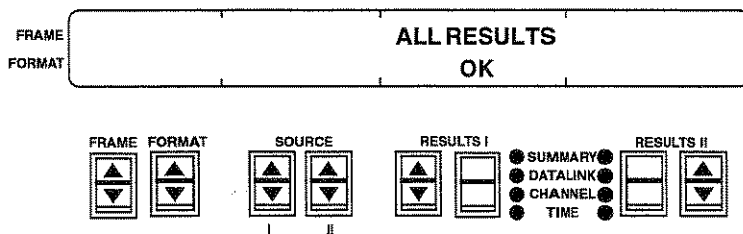

Testing the Remote Terminal (RT)

The following procedures test the RT alarm detection, Shelf B, C, and D switch to protect, and Shelf A maintenance test capabilities.

Verify RT Alarm Detection

1. **SOURCE I and II switches**

Select one of the following alarms and shelves:

SOURCE I	MAJOR	MINOR	PWR/MISC
SOURCE II	SHELF A		
	SHELF B		
	SHELF C		
	SHELF D		
	NO SHELF		

2. **INSERT switch**

Press this switch to insert and send the selected alarm to the RT. The switch LED flashes for three seconds. During the three seconds of flashing, the alarm is temporarily inhibited, the instrument is reconfigured, and the T1 signal from the SECONDARY RECEIVE input is passed on to the TRANSMIT output unaffected. When the **INSERT** switch LED stops flashing and illuminates, the alarm is inserted into the T1 signal. Repeat Step 1 as required.

3. **Alarm Control Unit (ACU) results interpretation**

Verify the RT channel bank ACU status LEDs function properly.

4. **Datalink results interpretation**

P/S DATALINK SYNC LOSS

If this message appears during testing the Shelf A (C for Mode 2) testing has failed, because the T-BERD DLC Analyzer Option lost datalink synchronization. Probable cause would be a bad DL card.

5. **INSERT switch**

Press this switch to stop sending the alarm to the RT. The switch LED goes out.

Verify Switch-to-Protection Capability

1. **SOURCE I and II switches**

Select Shelf B, C, or D to test the switch-to-protection capability. Refer to Application 21 Testing Shelf A Far-end Loop and Switch-to-Protection Operation to test the switch-to-protection capability for Shelf A.

SOURCE I SWPROT

SOURCE II SHELF B (Mode 1 only)
 SHELF C
 SHELF D (Mode 1 only)

2. **INSERT switch**

Press this switch to insert and send the selected command to the RT. The switch LED flashes for three seconds. During the three seconds of flashing, the command is temporarily inhibited, the instrument is reconfigured, and the T1 signal from the SECONDARY RECEIVE input is passed on to the TRANSMIT output unaffected. When the **INSERT** switch LED stops flashing and illuminates, the command is inserted into the T1 signal.

3. **Datalink results interpretation**

P/S SHELF x ON PROT

Both alarms indicate the office and the RT have switched Shelf x to the protection line successfully. These messages should be indicated at the RT and verified with the T-BERD DLC Analyzer Option. If only the *P SHELF x ON PROT* message appears, only the RT has switched Shelf x to the protection line.

WARNING: If the *SW PROT FAILED* message appears, the switch-to-protection sequence failed, do not continue with the procedure. This message could indicate that another line is already on the protection line. Disconnect from the circuit in accordance with the Disconnect T-BERD DLC Analyzer Option from the Circuit procedure.

4. **INSERT switch**

Press this switch to stop sending the command to the RT. The switch LED goes out.

Verify Mode I Maintenance Test Sequence

NOTE: The following procedure only verifies the channel can be accessed for maintenance testing (i.e., it performs setup for testing, but does not perform any of the tests). This procedure can only be performed on Shelf A.

1. **SOURCE I switch**
Select the MAINT command to establish the automated maintenance test procedure.
2. **SECONDARY CHANNEL switch**
Select the desired DS0 channel from 1 to 24 only.
3. **INSERT switch**
Press this switch to insert and send the MAINT command to the RT. The switch LED flashes for three seconds. During the three seconds of flashing, the MAINT command is temporarily inhibited, the instrument is reconfigured, and the T1 signal from the SECONDARY RECEIVE input is passed on to the TRANSMIT output unaffected. When the INSERT switch LED stops flashing and illuminates, the MAINT command is inserted into the T1 signal. The maintenance test is performed with the DS0 channel selected in Step 2.
4. **Verify transmitted maintenance test sequence**
Progress messages appear in lowercase in the SOURCE II display. These progress messages include, *hook/seize*, *proceed*, *succeed*, *test alarm* (means no response from the RT), *failed*, (means test alarm from RT). The *uppercase* messages are the expected responses:

NOTE: The T-BERD DLC Analyzer Option emulates the maintenance test generated from the COT.

- ◆ The *hook/seize* message indicates the T-BERD DLC Analyzer Option is waiting for the RT to respond with the *P HOOK/SEIZE* message.
- ◆ The *proceed* message indicates the T-BERD DLC Analyzer Option is waiting for the RT to respond with the *P PROCEED* message.

- ✦ The *succeed* message indicates the maintenance test sequence is successful and the *P HOOK/SEIZE* and *P PROCEED* appear.
- ✦ If the *abort* message appears and the RT only responds with a *P TEST ALARM* message, the RT may not have been able to seize the bypass pair.
- ✦ If the *abort* message appears and the RT responds with either the *P HOOK/SEIZE* or *PROCEED* message, an indeterminate problem occurred.
- ✦ If the *test alarm* message appears and the RT does not respond within the required time, either the subscriber channel unit or the CTU is not responding to the maintenance test.
- ✦ If the *test alarm* message appears and the RT only responds with the *P HOOK/SEIZE* message, the CTU may not be responding to the maintenance test sequence.

3. **INSERT switch**

Press this switch to stop sending the command to the RT. The switch LED goes out.

Disconnect the T-BERD DLC Analyzer Option

1. **INSERT switch**

Verify the switch LED is OFF before disconnecting the T-BERD DLC Analyzer Option from the circuit.

2. **TRANSMIT jack**

Disconnect the cable from the DSX-1 jack first. Then disconnect the cable from the T-BERD DLC Analyzer Option. If the 100 Ω terminator was used, unplug the terminator from the DSX-1 OUT jack and DSX-1 IN jack cable simultaneously.

NOTE: You may notice a brief burst of errors in the T1 signal when the cable is disconnected from the DSX-1 IN jack.

3. **PRIMARY RECEIVE and SECONDARY RECEIVE jacks**

Disconnect the cables from the DSX-1 MON jacks, then the T-BERD DLC Analyzer Option.

19. TESTING SHELF B, C, D, OR PROTECT BER PERFORMANCE

T-BERD DLC Analyzer Option Required

- ◆ Verify the bit error rate performance, switch to protection, and far-end loop response capabilities of Shelf B, C, D, or PROTECT at the RT.

Connect DLC Analyzer Option to the T-BERD 209A/211

1. **Apply power to power source**
If the T-BERD 209A/211 is supplying power, turn power ON. If the external power supply is supplying power, plug external power supply into 110 VAC.
2. **Connect coiled cable**
Connect the T-BERD DLC Analyzer Option coiled cable to either the T-BERD 209A/211 15-pin D connector or external power supply after applying power to the power source.
3. **INSERT switch**
Verify the switch LED is OFF before connecting the T-BERD DLC Analyzer Option to the circuit.

T-BERD DLC Analyzer Option Test Setup

1. **Configure the T-BERD DLC Analyzer Option:**

FRAME	SLC-M1 or SLC-M2.
FORMAT	DATLINK.
CODE	Set to appropriate coding.
RECEIVE INPUT	DSX-MON.
VOLUME	Set to mid-position.
TRANSMIT/LBO	Select 0 dB if transmitting into the span or select -15.0 dB if transmitting into the equipment.

NOTE: Do not attempt to perform a far-end loop on Shelf B or D of a Mode 2 DLC system.

2. **Circuit connections**

If at the CO, connect three cables as follows (see Figure 26):

Connect the first cable from the PRIMARY RECEIVE jack to the Shelf A span-side DSX-1 MON jack. Connect the second cable from the SECONDARY RECEIVE jack to the Shelf A equipment-side DSX-1 MON jack. Connect the third cable from the TRANSMIT jack to the Shelf A span-side DSX-1 IN jack.

If at the RT, connect three cables as follows:

Connect the first cable from the PRIMARY RECEIVE jack to the Shelf A equipment-side DSX-1 MON jack. Connect the second cable from the SECONDARY RECEIVE jack to the Shelf A span-side DSX-1 MON jack. Connect the third cable from the TRANSMIT jack to the Shelf A equipment-side DSX-1 IN jack.

NOTE: You may notice a brief burst of errors in the T1 signal when the cable is connected to the DSX-1 IN jack. If persistent errors are detected after the cable is connected, verify the resistor isolation at the DSX-1. If improper resistor isolation is determined, plug a 100Ω terminator into the appropriate DSX-1 OUT jack simultaneously with the cable from the TRANSMIT jack.

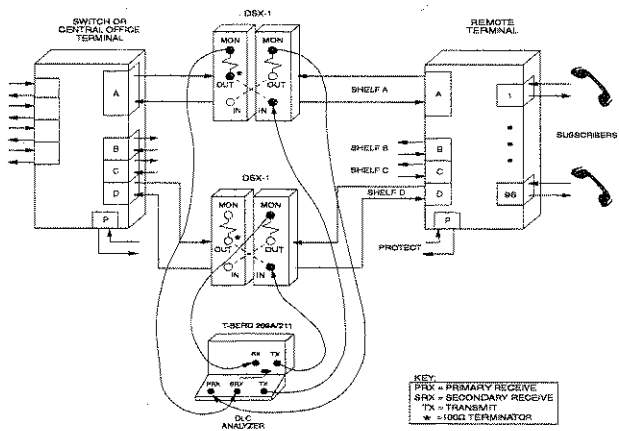

Figure 26
Testing Shelf B, C, D, or Protect BER Performance

DLC TESTING
APPLICATIONS

3. Press the **RESTART** switch

4. **Status LEDs**

Both primary and secondary T1 Pulses, Frame Sync, and B8ZS (if applicable) LEDs should illuminate. The Alarms LED may illuminate.

5. **RESULTS I switches**

Check the **SUMMARY** category. If errors or alarms are not detected, **ALL RESULTS OK** appears. If errors or alarms are detected, scroll through the **SUMMARY** category for specific errors or alarms. Check the other categories as required.

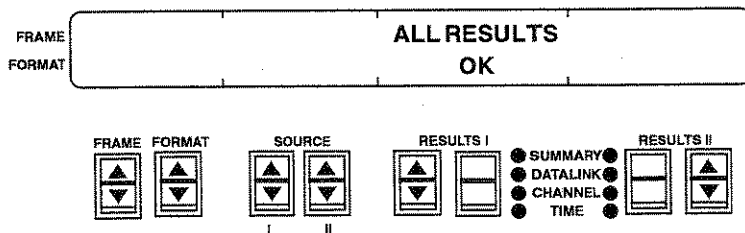

6. **SOURCE I and II switches**

Select **SOURCE I** for FELOOP and **SOURCE II** for either SHELF B, C, D or PROTECT.

7. **INSERT switch**

Press this switch to insert and send the far-end loop command to the RT. The switch LED flashes for three seconds. During the three seconds of flashing, the far-end loop command is temporarily inhibited, the instrument is reconfigured, and the T1 signal from the **SECONDARY RECEIVE** input is passed on to the **TRANSMIT** output unaffected. When the **INSERT** switch LED stops flashing and illuminates, the far-end loop command is inserted into the T1 signal. SHELF B, C, or D is automatically switched to the protection line and the SHELF B, C, D or PROTECT T1 line is looped back.

NOTE: When the far-end loopback command is transmitted, the command is automatically preceded by a switch-to-protection line command to prevent an interruption of the selected shelf.

8. **Datalink results interpretation**

P/S SHELF x ON PROT

Both alarms indicate the office and the RT have switched Shelf x to the protection line successfully. These messages should be indicated at the RT and verified with the T-BERDDLC Analyzer Option. If only the *P SHELF x ON PROT* message appears, only the RT has switched Shelf x to the protection line.

WARNING: If the *SW PROT FAILED* message appears, the switch-to-protection sequence failed, do not continue with the procedure. This message could indicate that another line is already on the protection line. Disconnect from the circuit in accordance with the Disconnect T-BERD DLC Analyzer Option from the Circuit procedure.

T-BERD 209A/211 Mainframe Test Setup

1. **Configure the T-BERD 209A/211 switches:**

MODE	Scroll to T1 D4 or T1 ESF mode, as appropriate.
PATTERN	Scroll to the appropriate test pattern.
TIMING	INT.
TEST	CONT.
CODE	AMI or B8ZS, as appropriate.
RECEIVE INPUT	DSX-MON.
TRANSMIT OUTPUT	Select 0 dB(DSX) if testing at the CO or -15 dB(DSX) if testing at the RT.

2. **Circuit connections**

If at the CO, connect a cable from the RECEIVE jack to the Shelf B, C, D, or PROTECT span-side DSX-1 OUT jack. Then, connect a cable from the TRANSMIT jack to the Shelf B, C, D, or PROTECT span-side DSX-1 IN jack.

If at the RT, connect a cable from the RECEIVE jack to the Shelf B, C, D, or PROTECT equipment-side DSX-1 OUT jack. Then, connect a cable from the TRANSMIT jack to the Shelf B, C, D, or PROTECT equipment-side DSX-1 IN jack.

DLC TESTING

APPLICATIONS

3. **Status LEDs**
The T1 Pulses, Pattern Sync, Frame Sync, and B8ZS (if applicable) LEDs should illuminate.
4. **RESULTS I Category switch**
Select the SUMMARY category.
5. **LOGIC ERROR INSERT switch**
Press the switch five times to verify the logic errors are received and the T1 circuit is looped back.

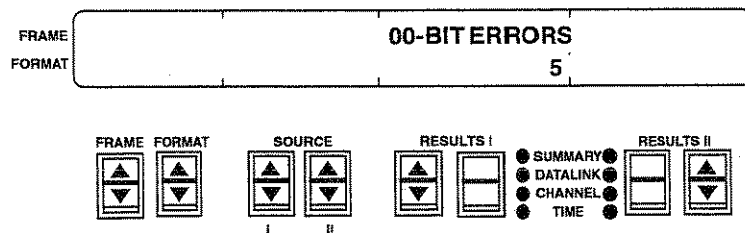

6. **Press the RESTART switch**
7. **RESULTS I switches**
Check the SUMMARY category. If errors are not detected, *ALL RESULTS OK* appears. If errors are detected, scroll through the SUMMARY category for specific errors. Check the other categories as required.
8. **Results interpretation**
 - 00-BIT ERRORS only**
Check the span before the DSX-1 by isolating sections and testing.
 - 25-VIOLATIONS only**
These errors typically indicate a local T1 span problem caused by a bad splice, water on the cable, crosstalk, bad repeater, or defective DSX jacks.
 - 00-BIT ERRORS and 25-VIOLATIONS**
These errors typically indicate a local T1 span problem caused by a bad splice, water on the cable, crosstalk, or defective DSX jacks.

40-RX FREQ, Hz

The DS1 received frequency should be 1.544 MHz \pm 58 Hz or 208 Hz for older transmission equipment. If the frequency is out-of-specification, check the transmission equipment timing or the network synchronization.

41-RX LEVEL (dBdsx)

The received level should be +4 to -4 dBdsx at the terminated DSX-1 OUT jacks. Incorrect levels could be caused by a faulty T1 line card or poor cabling between the DSX jack and the equipment.

Yellow Alarm LED

The far end sends a Yellow Alarm to indicate that it is not receiving a T1 signal. Sectionalize the T1 equipment further.

Disconnect the Test Sets

1. **T-BERD 209A/211 — Disconnect the cables**
When the test is complete, disconnect the cables from the SHELF B, C, D, or PROTECT DSX-1 jacks.
2. **T-BERD DLC Analyzer Option — INSERT switch**
Press this switch to release SHELF B, C, D, or PROTECT from the far-end loopback and protection line. Verify the switch LED extinguishes.
3. **T-BERD DLC Analyzer Option — TRANSMIT jack**
Disconnect the cable from the DSX-1 jack first. Then disconnect the cable from the T-BERD DLC Analyzer Option. If the 100 Ω terminator is used, unplug the terminator from the DSX-1 OUT jack and DSX-1 IN jack cable simultaneously.

NOTE: You may notice a brief glitch in the T1 signal when the cable is disconnected from the DSX-1 IN jack.
4. **PRIMARY RECEIVE and SECONDARY RECEIVE jacks**
Disconnect the cables from the DSX-1 MON jacks, then the T-BERD DLC Analyzer Option.

20. VERIFYING RING GENERATION

T-BERD DLC Analyzer Option Required

- Verify the ring generator is functioning properly at the RT.

Connect DLC Analyzer Option to T-BERD 209A/211

1. **Apply power to power source**
If the T-BERD 209A/211 is supplying power, turn power ON. If the external power supply is supplying power, plug external power supply into 110 VAC.
2. **Connect coiled cable**
Connect the T-BERD DLC Analyzer Option coiled cable to either the T-BERD 209A/211 15-pin D connector or external power supply after applying power to the power source.
3. **INSERT switch**
Verify the switch LED is OFF before connecting the T-BERD DLC Analyzer Option to the circuit.

T-BERD DLC Analyzer Option Test Setup

1. **Configure the T-BERD DLC Analyzer Option:**

FRAME	Scroll to appropriate format.
FORMAT	CHANNEL.
CODE	Set to appropriate coding.
RECEIVE INPUT	DSX-MON.
VOLUME	Set to mid-position.
CHANNEL/VF DROP	Select PRIMARY, SECONDARY, or BOTH.
CHANNEL/CHANNEL SCROLL	Select SEPARATE or BOTH.
CHANNEL/TRUNK TYPE	Select the signaling protocol, as appropriate.
TRANSMIT/LBO	Select 0 dB if transmitting into the span or select -15.0 dB if transmitting into the equipment.

2. **Circuit connections**

If at the CO, connect three cables as follows (see Figure 27):

Connect the first cable from the PRIMARY RECEIVE jack to the appropriate span-side DSX-1 MON jack. Connect the second cable from the SECONDARY RECEIVE jack to the corresponding equipment-side DSX-1 MON jack. Connect the third cable from the TRANSMIT jack to the corresponding span-side DSX-1 IN jack.

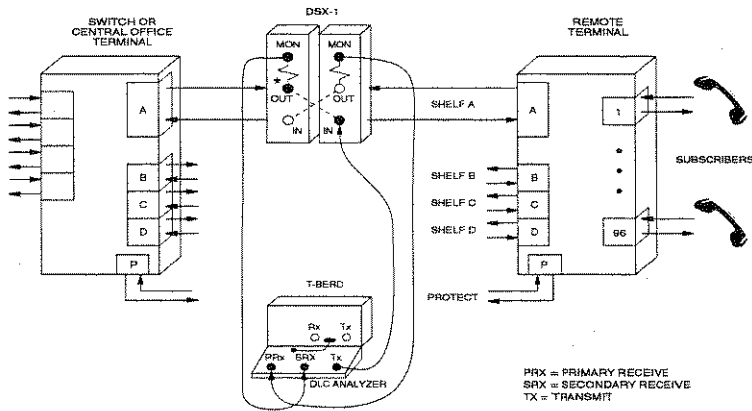

Figure 27
Testing Ring Generators

DLC TESTING
APPLICATIONS

If at the RT, connect three cables as follows:

Connect the first cable from the PRIMARY RECEIVE jack to the appropriate equipment-side DSX-1 MON jack. Connect the second cable from the SECONDARY RECEIVE jack to the corresponding span-side DSX-1 MON jack. Connect the third cable from the TRANSMIT jack to the corresponding equipment-side DSX-1 IN jack.

NOTE: You may notice a brief burst of errors in the T1 signal when the cable is connected to the DSX-1 IN jack. If persistent errors are detected after the cable is connected, verify the resistor isolation at the DSX-1. If improper resistor isolation is determined, plug a 100 Ω terminator into the appropriate DSX-1 OUT jack simultaneously with the cable from the TRANSMIT jack.

3. Press the RESTART switch

4. Status LEDs

Both primary and secondary T1 Pulses, Frame Sync, and B8ZS (if applicable) LEDs should illuminate. The Alarms LED may illuminate.

5. RESULTS switches

Check the SUMMARY category. If errors or alarms are not detected, ALL RESULTS OK appears. If errors or alarms are detected, scroll through the SUMMARY category for specific errors or alarms. Check the other categories as required.

Select one of the following CHANNEL category test results to monitor the channel signaling: P TRAFFIC CHANNEL AB, P TRAFFIC CHANNEL ABCD.

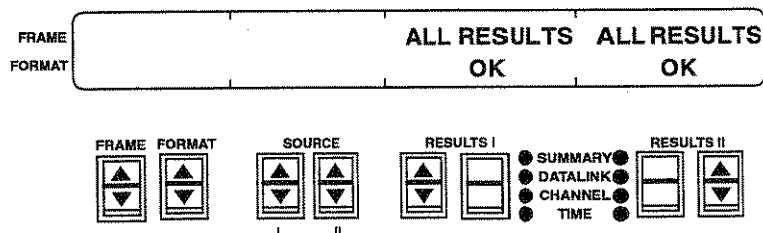

6. **SECONDARY CHANNEL switch**
Select the desired DS0 channel.
7. **INSERT switch**
Press this switch to insert the signal. The switch LED flashes for three seconds. During the three seconds of flashing, the signal is temporarily inhibited, the instrument is reconfigured, and the T1 signal from the SECONDARY RECEIVE input is passed on to the TRANSMIT output unaffected. When the **INSERT** switch LED stops flashing and illuminates, the signal is inserted into the T1 signal.
8. **RING switch**
Press this switch to ring the local subscriber loop. Verify the ring back signal is heard from the speaker. The switch LED illuminates while active, and the **ABCD** switches are updated.

NOTE: The T-BERD DLC Analyzer Option emulates the central office terminal.
9. **DS0 channel results interpretation**
P/S TRAFFIC CHANNEL AB or ABCD
Monitor the channel signaling bits in both directions.

Disconnect the T-BERD DLC Analyzer Option

1. **TRANSMIT jack**
Disconnect the cable from the DSX-1 jack first. Then disconnect the cable from the T-BERD DLC Analyzer Option. If the 100 Ω terminator is used, unplug the terminator from the DSX-1 OUT jack and DSX-1 IN jack cable simultaneously.

NOTE: You may notice a brief glitch in the T1 signal when the cable is disconnected from the DSX-1 IN jack.
2. **PRIMARY RECEIVE and SECONDARY RECEIVE jacks**
Disconnect the cables from the DSX-1 MON jacks, then the T-BERD DLC Analyzer Option.

21. VERIFYING CHANNEL UNIT SIGNALING

T-BERD DLC Analyzer Option Required

- * Test on-hook, off-hook, and signaling on one or all 24 channels on a shelf.

Connect DLC Analyzer Option to the T-BERD 209A/211

- 1. Apply power to power source**
If the T-BERD 209A/211 is supplying power, turn power ON. If the external power supply is supplying power, plug external power supply into 110 VAC.
- 2. Connect coiled cable**
Connect the T-BERD DLC Analyzer Option coiled cable to either the T-BERD 209A/211 15-pin D connector or external power supply after applying power to the power source.
- 3. INSERT switch**
Verify the switch LED is OFF before connecting the T-BERD DLC Analyzer Option to the circuit.

T-BERD DLC Analyzer Option Test Setup

- 1. Configure the T-BERD DLC Analyzer Option:**

FRAME	Scroll to appropriate framing.
FORMAT	CHANNEL.
CODE	Set to appropriate coding.
RECEIVE INPUT	DSX-MON.
VOLUME	Set to mid-position.
CHANNEL/VF DROP	Select PRIMARY, SECONDARY, or BOTH.
CHANNEL/CHANNEL SCROLL	Select SEPARATE or BOTH.
CHANNEL/TRUNK TYPE	Select the signaling protocol, as appropriate.
TRANSMIT/LBO	Select 0 dB if transmitting into the span or select -15.0 dB if transmitting into the equipment.

2. **Circuit connections**

If at the CO, connect three cables as follows (see Figure 28):

Connect the first cable from the PRIMARY RECEIVE jack to the appropriate equipment-side DSX-1 MON jack. Connect the second cable from the SECONDARY RECEIVE jack to the corresponding span-side DSX-1 MON jack. Connect the third cable from the TRANSMIT jack to the corresponding equipment-side DSX-1 IN jack.

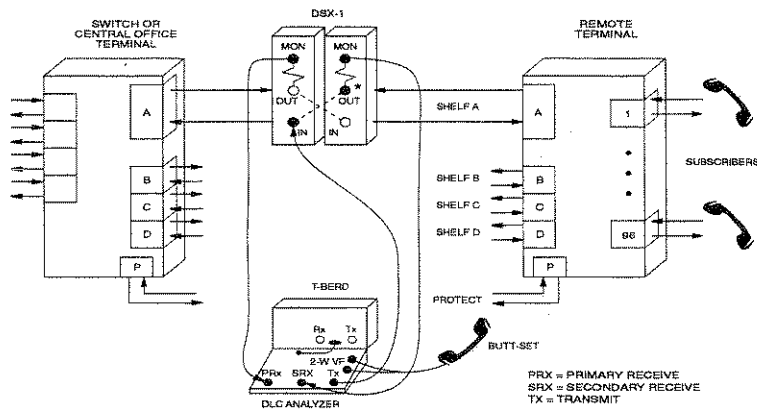

fig 28

Figure 28
Verifying Channel Unit Signaling

DLC TESTING
APPLICATIONS

If at the RT, connect three cables as follows:

Connect the first cable from the PRIMARY RECEIVE jack to the appropriate span-side DSX-1 MON jack. Connect the second cable from the SECONDARY RECEIVE jack to the corresponding equipment-side DSX-1 MON jack. Connect the third cable from the TRANSMIT jack to the corresponding span-side DSX-1 IN jack.

NOTE: You may notice a brief burst of errors in the T1 signal when the cable is connected to the DSX-1 IN jack. If persistent errors are detected after the cable is connected, verify the resistor isolation at the DSX-1. If improper resistor isolation is determined, plug a 100Ω terminator into the appropriate DSX-1 OUT jack simultaneously with the cable from the TRANSMIT jack.

3. **2-Wire VF Interface**

Connect a butt-set to the 2-wire VF posts on the right side near the RS-232 interface. Leave the butt-set **MON/TALK** switch in the MON or released position.

4. **Press the RESTART switch**

5. **Status LEDs**

Both primary and secondary T1 Pulses, Frame Sync, and B8ZS (if applicable) LEDs should illuminate. The Alarms LED may illuminate.

6. **RESULTS | switches**

Check the SUMMARY category. If errors or alarms are not detected, *ALL RESULTS OK* appears. If errors or alarms are detected, scroll through the SUMMARY category for specific errors or alarms. Check the other categories as required.

Select one of the following CHANNEL category test results to monitor the channel signaling: P/S TRAFFIC CHANNEL AB, P/S TRAFFIC CHANNEL ABCD.

7. **SOURCE | switch**

Set to VF INTF.

8. **SECONDARY CHANNEL switch**

Select the desired DS0 channel.

9. **INSERT switch**

Press this switch to test from the 2-wire VF interface. The switch LED flashes for three seconds. During the three seconds of flashing, the inserted source test signal is temporarily inhibited, the instrument is reconfigured, and the T1 signal from the SECONDARY RECEIVE input is passed on to the TRANSMIT output unaffected. When the **INSERT** switch LED stops flashing and illuminates, the new source test signal is inserted into the T1 signal.

10. **VOLUME control**

Adjust the control to monitor the selected DS0 channel through the speaker. Verify the line is idle.

11. **OFF HOOK switch**

Press this switch to place the channel off hook. Note that the dial tone can be heard from the speaker. The switch LED illuminates while active and the **ABCD** switches are updated. The **ON HOOK** switch LED goes out and the **ABCD** switches indicate the change.

NOTE: If the dial tone is not heard, verify the trunk type signaling protocol is properly set by the CHANNEL/TRUNK TYPE auxiliary function. Also check the volume level of the speaker.

12. **Butt-set**

Press the **MON/TALK** switch to the TALK position. Verify dial tone is heard.

Dial the telephone number. Verify ringing is heard and the telephone is answered.

Press the **MON/TALK** switch to the MON position.

13. **ON HOOK switch**

Press this switch to place the channel on hook. The switch LED illuminates while active and the **ABCD** switches are updated. Verify the line is idle and dial tone is not heard from the butt-set.

DLC TESTING
APPLICATIONS

14. **DS0 channel results interpretation**
P/S TRAFFIC CHANNEL AB or ABCD
Monitor the channel signaling bits in both directions.

Disconnect the T-BERD DLC Analyzer Option

1. **TRANSMIT jack**
Disconnect the cable from the DSX-1 jack first. Then disconnect the cable from the T-BERD DLC Analyzer Option. If the 100 Ω terminator is used, unplug the terminator from the DSX-1 OUT jack and DSX-1 IN jack cable simultaneously.

NOTE: You may notice a brief glitch in the T1 signal when the cable is disconnected from the DSX-1 IN jack.
2. **PRIMARY RECEIVE and SECONDARY RECEIVE jacks**
Disconnect the cables from the DSX-1 MON jacks, then the T-BERD DLC Analyzer Option.
3. **Butt-set**
Disconnect from the 2-wire VF posts.

22. CHECKING SLC MODE 2 TIMESLOT MAPPING

T-BERD DLC Analyzer Option Required

- * Verify the Mode 2 timeslot channel mapping.

Connect DLC Analyzer Option to the T-BERD 209A/211

1. **Apply power to power source**
If the T-BERD 209A/211 is supplying power, turn power ON. If the external power supply is supplying power, plug external power supply into 110 VAC.
2. **Connect coiled cable**
Connect the T-BERD DLC Analyzer Option coiled cable to either the T-BERD 209A/211 15-pin D connector or external power supply after applying power to the power source.

T-BERD DLC Analyzer Option Test Setup

1. **Configure the T-BERD DLC Analyzer Option:**

FRAME	SLC-M2.
FORMAT	CHANNEL.
CODE	Set to appropriate coding.
RECEIVE INPUT	DSX-MON.
VOLUME	Set to mid-position.
CHANNEL/VF DROP	Select PRIMARY, SECONDARY, or BOTH.
CHANNEL/CHANNEL SCROLL	Select SEPARATE or BOTH.
TRANSMIT/LBO	Select 0 dB if transmitting into the span or select -15.0 dB if transmitting into the equipment.

DLC TESTING
APPLICATIONS

2. **Circuit connections**

If at the CO, connect two cables as follows (see Figure 29):

Connect the first cable from the PRIMARY RECEIVE jack to the Shelf A equipment-side DSX-1 MON jack. Connect the second cable from the SECONDARY RECEIVE jack to the Shelf A span-side DSX-1 MON jack.

If at the RT, connect two cables as follows:

Connect the first cable from the PRIMARY RECEIVE jack to the Shelf A span-side DSX-1 MON jack. Connect the second cable from the SECONDARY RECEIVE jack to the Shelf A equipment-side DSX-1 MON jack.

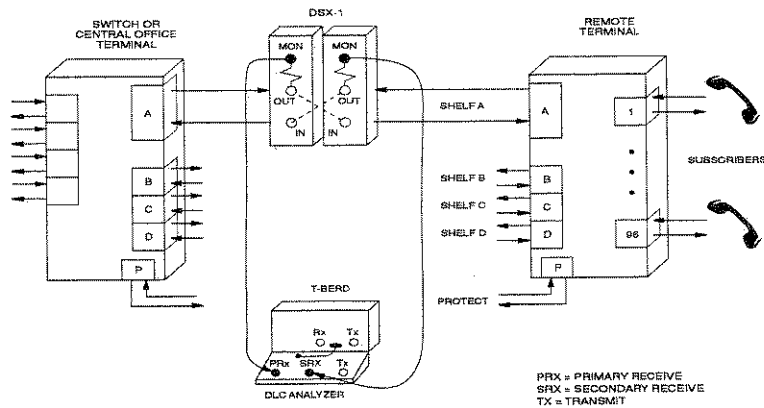

Figure 29
Checking SLC Mode 2 Timeslot Mapping

3. **Press the RESTART switch**

4. **Status LEDs**

The primary and secondary T1 Pulses, Frame Sync, and B8ZS (if applicable) LEDs should illuminate. The Alarms LED may illuminate.

5. **RESULTS I switches**

Select the CHANNEL category P/T S CHAN result. Determine which timeslot or channel you want to monitor. The timeslots are indicated across the top line. The active timeslots have the mapped channel number below it. The “— —” indicates an unassigned timeslot.

FRAME	P/T S	01	02	03	04	05	06	07	08	09	10	11	12
FORMAT	CHAN	01	03	05	07	10	22	--	24	--	36	--	--

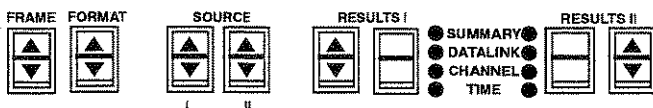

Press the **RESULTS I Results** switch to scroll to timeslots 13 to 24.

FRAME	P/T S	13	14	15	16	17	18	19	20	21	22	23	24
FORMAT	CHAN	04	--	--	15	20	12	--	02	--	11	--	--



NOTE: The timeslot channel assignments are valid only when monitored from the CO.

6. **PRIMARY CHANNEL switch**

Select the channel you want to monitor by displaying the *timeslot* number in the channel display. For example, to monitor channel 04 above, press the **PRIMARY CHANNEL** switch to display timeslot 13, monitor channel 15 by displaying timeslot 16.

7. **RESULTS I Results switch**

Select the CHANNEL category P/S TRAFFIC TIMESLOT AB result to monitor the timeslot signaling bits.

DLC TESTING

APPLICATIONS

FRAME	P	TRAFFIC	A	101010	101010	101010	101010
FORMAT		TIMESLOT	B	101010	101010	101010	101010

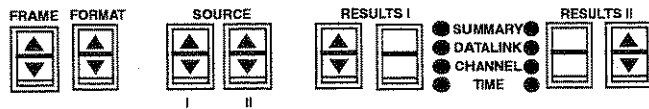

NOTE: The **ABCD** switches are functional in all frame modes. However, the **ON HOOK**, **OFF HOOK**, and **RING** switches are not functional in the SLC-M2 mode.

Disconnect the T-BERD DLC Analyzer Option

1. **PRIMARY RECEIVE and SECONDARY RECEIVE jacks**
Disconnect the cables from the DSX-1 MON jacks, then the T-BERD DLC Analyzer Option.