



DLF-100-50-250

OPERATOR'S MANUAL

DYNALOAD DIVISION
36A NEWBURGH ROAD, HACKETTSTOWN, NJ 07840
PHONE (908) 850-5088 FAX (908) 850-0679

T A B L E O F C O N T E N T S

<u>SECTION</u>	<u>PAGE</u>
1. INTRODUCTION	1
2. SPECIFICATIONS	2
3. OPERATING INSTRUCTIONS	4
3.1 Constant Resistance Mode	5
3.2 Constant Current Mode	5
3.3 Pulse Mode	6
3.4 External Modulation	7
3.5 Power Rating	8
3.6 Protective Circuits	8
3.7 Special Applications	8
3.8 Effects of Cable Inductance on Pulse Loading	9
4. CALIBRATION PROCEDURES	11
4.1 Current Sample Calibrate	11
4.2 Remote Programming	11
4.3 Voltmeter Calibrate	11
4.4 Ammeter Calibrate	12
4.5 Constant Current Calibrate	12
4.6 Constant Resistance Calibrate	12
4.7 Current Limit Calibrate	13
4.8 Power Limit Calibrate	13
4.9 Overvoltage Calibrate	13

ILLUSTRATIONS

Front Panel Layout	14
Calibration Setup	15
Printed Circuit Board Layout	16
Schematic	17

INTRODUCTION

The Dynaload is a precision instrument which simulates electrical loads to test power supplies, generators, servo systems, batteries, and similar electrical power sources. It simulates, at the option of the user, resistive loads (amps/volt) or may be switched to a constant current load characteristic (current regulated at a pre-selected value). Provisions are also made for external programming in automated test setups. The external programming voltage is from 0-10V, with an input impedance of 10K minimum. Load current is directly proportional to the programming voltage.

The meter normally reads average pulse current, so for accuracy when loading in the pulse mode it is recommended to monitor the current sample output.

The circuit breaker used to connect the source to the power devices in the load is electronically controlled and senses overvoltage.

In the event of an overvoltage condition protection circuits open the electronic circuit breaker. In the event of an overcurrent or overpower condition, circuitry is activated to limit the load current.

SPECIFICATIONS

The following specifications apply:

Load Voltage:	0-100V
Load Current:	0-50A
Average Power Dissipation:	0-250W
Self-Protection:	Overvoltage--less than 120V
	Overcurrent--less than 60A
	Over-power --less than 300W

Front Panel Switches - Refer to front panel layout

- S101 AC, Power ON/OFF Switch
- S1 Voltmeter Range Select Switch
- S2 Ammeter Range Select Switch
- S3 DC Load ON/OFF Switch

MODE SELECTION

- S4 5A DC LOAD - 0 to 5A constant current mode which is controlled by the front panel DC Load adjust.
- S5 50A DC LOAD - 0 to 50A constant current mode which is controlled by the front panel DC Load adjust.
- S6 2A/V DC LOAD - 0 to 2A/V constant resistance mode which is adjusted by the front panel DC Load adjust.
- S7 20A/V DC LOAD - 0 to 20A/V constant resistance mode which is adjusted by the front panel DC Load adjust.
- S8 5A PULSE LOAD - 0 to 5A pulse mode. The amplitude, frequency, duty cycle and DC baseline are adjustable by the front panel controls.
- S9 50A PULSE LOAD - 0 to 50A pulse mode. The amplitude, frequency, duty cycle and DC baseline are adjustable by the front panel controls.
- S10 REMOTE PROGRAM - In this mode the user can program the current level with a 0 to 10V programming voltage applied to J101 on the rear panel. The front panel controls are locked out.

S11 SHORT CIRCUIT - Drives load to saturation. Effective resistance is less than .05 ohms.

FRONT PANEL ADJUSTMENTS

Refer to Front Panel Layout.

DC Load Adjust - Coarse and fine adjust controls with a 10 to 1 ratio for precise setting of load current for the constant resistance and constant current functions. This control is also functional in the pulse mode to adjust the DC load component.

Pulse Amplitude - Coarse and fine adjust controls with a 10 to 1 ratio for setting the peak current in the pulse mode, the maximum setting is 100 Amps peak.

Freq. Adj. - Coarse and fine controls adjust the frequency of the pulse generator.

Width - Adjusts the percentage of the on time to off time ratio of the pulse generator a minimum of 10% on time, to maximum of 90% on time can be achieved.

FRONT PANEL STATUS INDICATORS

- DC This indicator is on when the DC circuit breaker is engaged.
- OV When an overvoltage condition exists this alarm will light and the DC breaker will disengage.
- OC This alarm will light when the Dynaload is in current limit.
- OP This alarm will light when the Dynaload has reached power limit.
- OT If the Dynaload reaches overtemperature this alarm will light and the load will stop drawing current.
- LOC This indicator will be on when one of the local modes are selected.
- REM This indicator will light when the Dynaload is in the remote programming mode.

REAR PANEL CONNECTIONS

- E+ Positive Load Input
- E- Negative Load Input
- J103 AC, Input Connector
- J101 Program Input Connector

OPERATING INSTRUCTIONS

The following procedure is recommended for connecting the Dynaload: The AC and DC Dynaload switches should be turned off so that the load is disconnected. The load adjustment controls should be set in the counterclockwise position. The mode selector switch should be set to the appropriate mode to be used. The Dynaload should be plugged into standard 115V, 50-60 Hz power (optional input voltage ranges are available), and connections should be made from the source to be tested to the appropriate load terminals of the Dynaload. (E+ and E- on the rear of the unit.) If external modulation is to be used, the external programming voltage should also be connected.

With the AC power switch on, the digital meters should turn on. The DC-on should now be actuated. The front panel Dynaload voltmeter should indicate the source voltage. (If the circuit breaker does not close, or if there is no indication of source voltage, check all the external connections for voltage and polarity.) The load may now be increased by turning the load adjustment controls clockwise until the appropriate load is obtained. External instrumentation may be used to monitor current waveforms and eliminate the effects of line voltage drops at high currents.

3.1 Constant Resistance Mode (Amps/Volt)

Two scales are provided, 0-2A/V and 0-20A/V. Minimum resistance on the 0-2A/V range is .5 ohms, and minimum resistance on the 0-20A/V range is .05 ohms. For example, to test a 12V battery with a two ohm resistive load, the 2A/V mode should be selected, and the coarse and fine load adjust controls adjusted to obtain the 6A load. The two ohm load is now set, and this resistance value will remain constant for the full range of input voltage.

The resistive load characteristics of the dynaload simulate a constant resistance down to approximately 1 to 2V input; i.e., for a given resistance setting, the current is directly proportional to the voltage over wide dynamic ranges. In the very low voltages, the power transistors will saturate.

3.2 Constant Current Mode

Some power sources, such as variable power supplies, are rated at a fixed maximum load current and adjustable over a predetermined voltage range: i.e., 5-10V @ 20A. If the resistive load characteristic were used for this type of test, it would be necessary to reset the load each time the power supply voltage was changed, in order to maintain the full load current. However, if the load is set to the 50A constant current mode, a load of 20A is applied, then the power supply can be adjusted from 5-10V, and the load current will remain constant.

It should be noted that many power supplies are designed for short circuit protection by internal current limiting and feedback, and therefore, may not start up into a constant current type of load. Accordingly, the constant resistance characteristic should be used as a load when simulating short circuit protection and recovery of most power supplies, unless otherwise specified by the manufacturer.

3.3 Pulse Mode

The pulse load may be varied from 0-5A or from 0-50A peak current by the pulse amplitude control on the front panel. The frequency may be varied from approximately 800Hz to 20KHz by the frequency control on the front panel and the duty cycle of the square wave can be adjusted from 10% to 90% with the width control on the front panel. This pulse load may be superimposed on top of a constant DC load, which may be selected by the DC load control on the front panel.

If the pulse is to be used down to a no-load state,* the DC load controls should be turned fully counterclockwise. The maximum total of the pulse and DC load will be limited around 55A by the internal current limit protection.

The pulse load is most effective with some steady state load current to which the pulse added. Pulsing from zero load creates a delay in the pulse rise and fall. The pulse current should be monitored on an oscilloscope to assure proper operation.

The rise time of the load current pulse is approximately 15 us for a 5-50A pulse and return. Operation at low voltages (less than 1V) may result in transient to less than 1V at the input terminal due to $L di/dt$ drops in the power leads. This in turn may cause pulse waveform distortion and the user should monitor the load current waveforms to assure proper operation.

The DC and pulse load may be mixed in any combination through the use of the separate DC load coarse and fine and the pulse load coarse and fine controls.

3.4 External Modulation

In the external modulation mode, the dynaload acts as a constant current load with the constant current proportional to the external voltage applied to J101.

The dynaload will program from 0-50A with a 0-10V @ 1 MA control signal. The input impedance of the external modulation terminals is approximately 10K ohms.

The linearity of the external program is set to be within $\pm 1\%$ above 1A.

The load may be pulsed or it will follow the programming waveform within the transient response limits of the Dynaload.

3.5 Power Rating

The model DLF 100-50-250 will dissipate 250W continuously. In order to assure that overheating does not occur, the rear and top of the Dynaload should be clear for the air intake and the air exhaust; i.e., the cooling air enters from the top and leaves from the rear. The dynaload should periodically be checked for dust accumulation.

3.6 Protective Circuits

The Dynaload has internal current limiting at approximately 60A maximum. In the event that an overvoltage is applied to the dynaload, an internal overvoltage circuit will open the circuit breaker, thereby protecting all internal circuits.

The voltage current product (power) is also monitored to prevent an overpower condition from happening. Accordingly, the current limit characteristic is set to approximately 60A, which is maintained to approximately 4.2V. At this point, the current limit characteristic is reduced as the input voltage is increased, thereby limiting the maximum power which may be programmed into the dynaload.

3.7 Special Applications

The Dynaload may be used for AC load testing, within its ratings, by the use of an external bridge rectifier, so that the dynaload sees pulsating DC, but the AC source sees an AC load. The

Effect of the rectifier is to slightly distort the Dynaload characteristics at low voltages and currents. The Dynaload is not normally recommended for testing AC sources above 1000 cycles unless the user specifically recognizes the load characteristics at higher frequencies.

3.8 Effects of Cable Inductance on Pulse Loading

When the Dynaload is used for high current pulse loading, the effects of cable inductance must be considered. A special 5 foot coaxial power cable is provided with the DLF to minimize wiring inductance and its use is strongly recommended. Other types of wiring or larger cables will limit speed of response and may cause ringing, etc.

The critical parameters are the 15 microsecond rise time and the 1.0V minimum compliance specifications. If the inductance of the cables from the voltage source to the dynaload is great enough to cause the voltage at the Dynaload to go below 1.0V, then excessive current wave form distortion will occur. This is because the power devices are driven into saturation in an attempt to reach the programmed current which cannot occur because of the low Drain voltage. Once in a saturated state, the response time is much slower. The result is a significant overshoot on the rising edge of the pulse.

The following is suggested to partially compensate for longer
lower leads:

1. 1 microhenry = 2.4 feet of wire (total).
2. 50A @ 15 microseconds rise time = 3.3 volt drop with 1 microhenry.
3. The inductive drop cannot exceed the difference between the source voltage and the 1.0V compliance.

For example: To test a 5.0v source with a 50A pulse, the maximum cable length would be:

$$E \text{ Max drop} = 4.0V$$

$$E = L(di/dt) \quad 4.0V = L(50/15\mu s)$$

$$L = 1.2 \text{ microhenries maximum}$$

$$\text{Maximum cable length} = 2.88 \text{ feet total}$$

Since this distance is relatively short, a low inductance cable is provided. This cable (5 feet long with an overall inductance of 5 nH) is compensated for internally by the load.

If the distance from the load to the source must be greater than this, there are several methods to increase the maximum distance. One way is to use several insulated conductors. This cuts the inductance in half if 4 are used instead of 2, or by

ne-third if 6 are used. This doubles or triples the maximum length, respectively. If oscillations or ringing occur with longer cables, the unit may be stabilized by an electrolytic capacitor in series with a damping resistor across the terminals of the load.

CALIBRATION PROCEDURES (Refer to FIG. 1)

4.1 Current Sample calibrate

- A. Set current sample for 10.0V with Dynaload drawing 50A, adjust R2(CS CAL) on the A8 PC board.
- B. With the Dynaload drawing 5A set current sample for 1.0V, adjust R8(CS OFFSET) on A8.
- C. Repeat these two steps until no further adjustments are necessary.

4.2 Remote Programing Calibrate

- A. Set programming source to 10.0V adjust R1(REMOTE) on A1 so the Dynaload draws 50.0A
- B. Set program source for 1.0V and adjust R14(OFFSET) on A1 so the load draws 5.0A.
- C. Repeat steps A and B until no further adjustments are necessary. Check programming linearity at 1.0V intervals.

4.3 Voltmeter Calibrate

- A. Select the high range and apply 100V to the load inputs. Adjust R24(HV) on A5 so the voltmeter includes the correct voltage.

- B. Select the low range and apply 10V to the load inputs. Adjust R26(LV) on A5 so the voltmeter indicates the correct voltage.

4.4 Ammeter Calibrate

- A. Select the high range and with the Dynaload drawing 50.0A adjust R28(HA) on A5 so the ammeter indicates the correct current.
- B. Select the low range and with the Dynaload drawing 15.0A adjust R30(LA) on A5 so the ammeter indicates the correct current.

4.5 Constant Current Calibrate

- A. Select the 5A constant current mode and turn the DC Load coarse adjust fully clockwise. Adjust R2(LCC) on A4 so the load draws 5.0A.
- B. Select the 50A constant current mode and turn the DC Load coarse adjust fully clockwise. Adjust R4(HCC) on A4 so the load draws 50.0A.

4.6 Constant Resistance Calibrate

- A. Select the 2A/V constant resistance mode, apply 10.0V to DC load inputs and turn the DC Load coarse adjust fully clockwise. Adjust R6(LA/V) on A4 until the load draws 20.0A.
- B. Select the 20A/V constant resistance mode, apply 2.0V to the DC load inputs and turn the DC Load coarse adjust fully clockwise. Adjust R8(HA/V) so the load draws 40.0A

4.7 Current Limit Calibrate

Select the 20A/V constant resistance range and apply 3V to the load inputs. Increase the current to between 52 and 55 amps. Adjust R7(CL) on A1 until current limit is achieved and the OC alarm lights.

4.8 Power Limit Calibrate

Select the 0-50A constant current mode and apply 20V to the load inputs. Increase the current to 15A and adjust R10(PL) on A1 to limit the current between 14A and 15A at 20V input. Check that the PL alarm lights. Increase input voltage to 50V and the current should be limited between 5.5A and 6.0A.

4.9 Overvoltage Calibrate

Set overvoltage trip point between 110V and 120V by adjusting R24(OV) on A1. Check that the OV alarm lights.

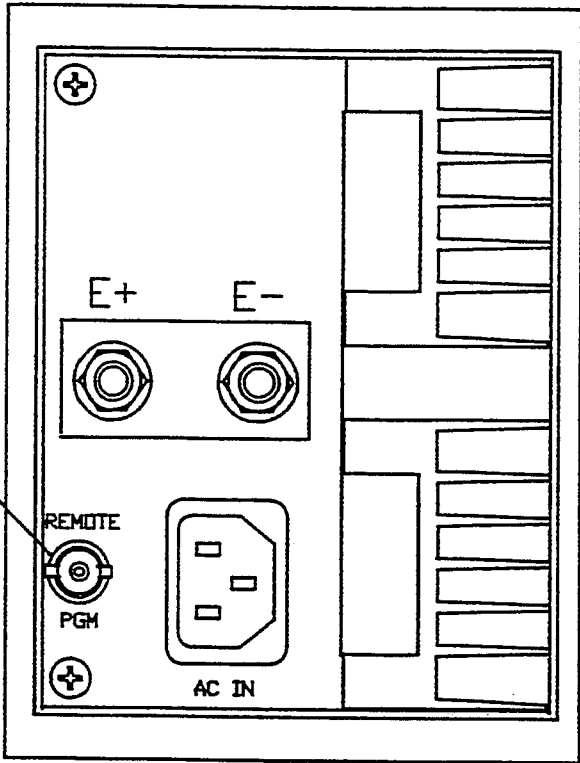

REAR

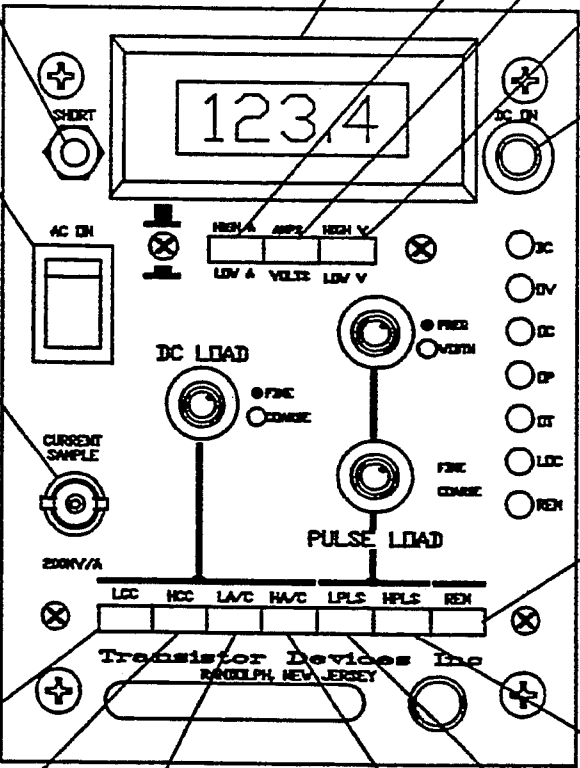

FRONT

J101

S101

S11

J102

REAR

M101

S1

S2

S3

S12

S10

S4

S5

S6

S7

S8

S9

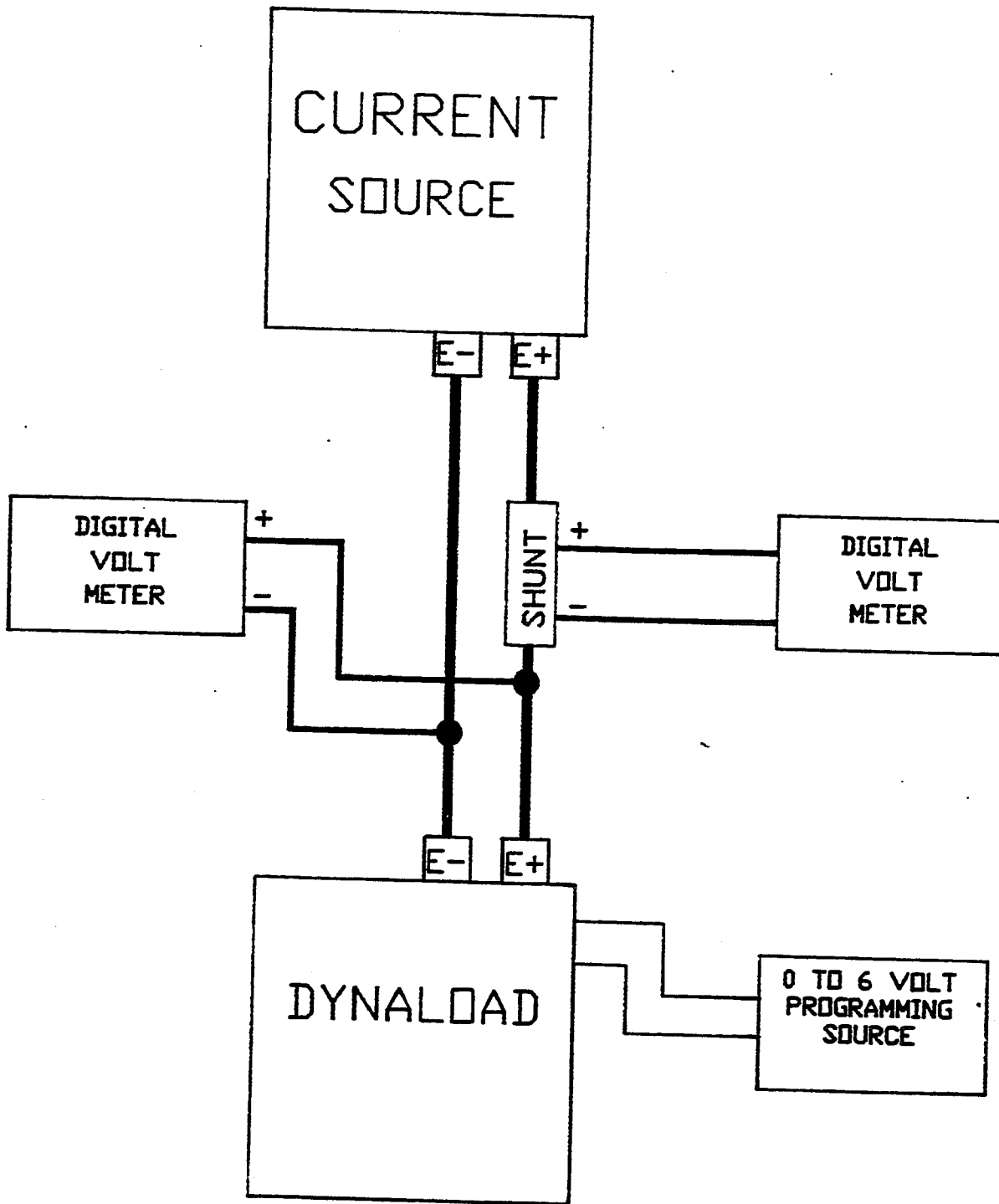
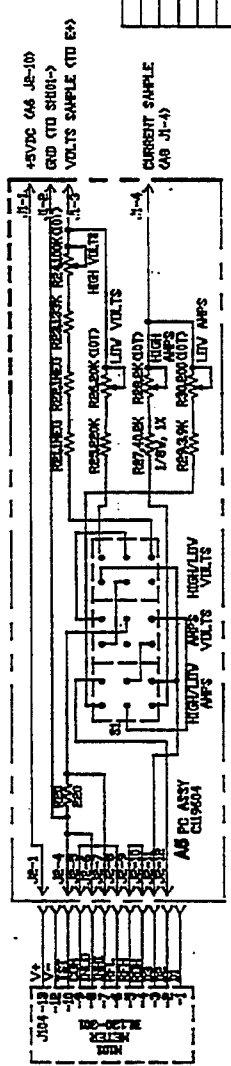
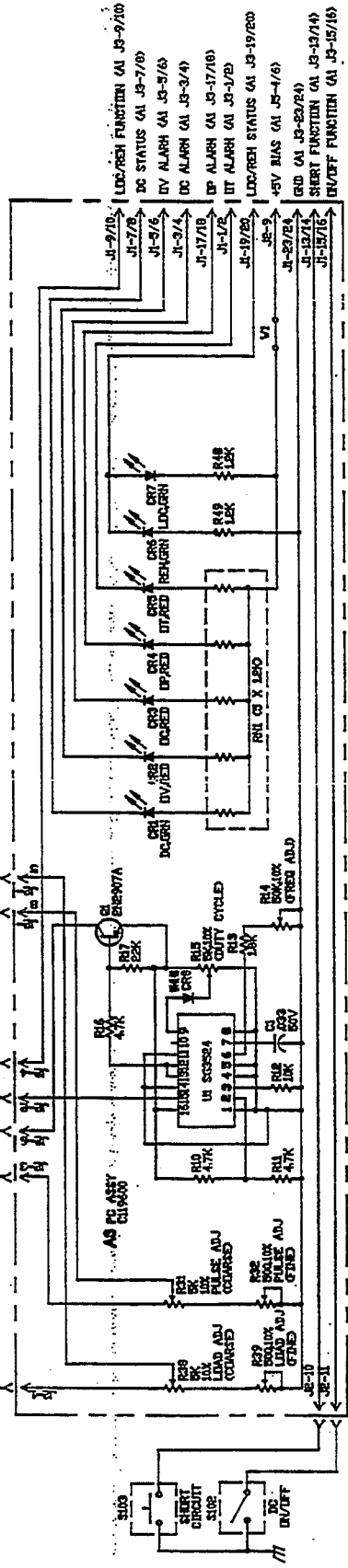
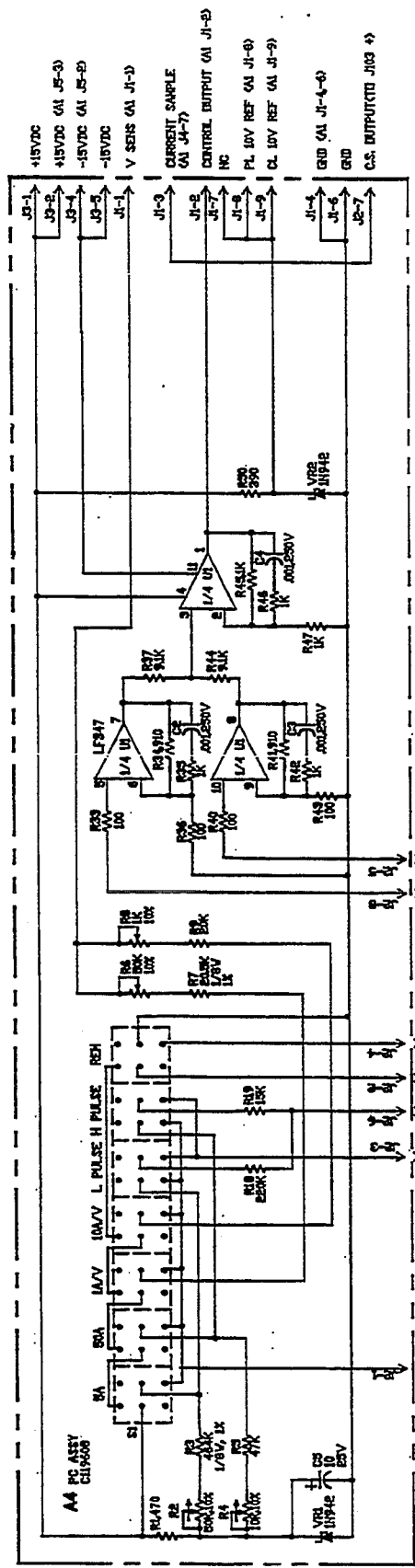
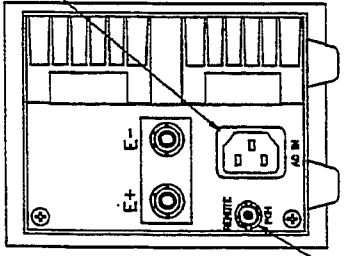
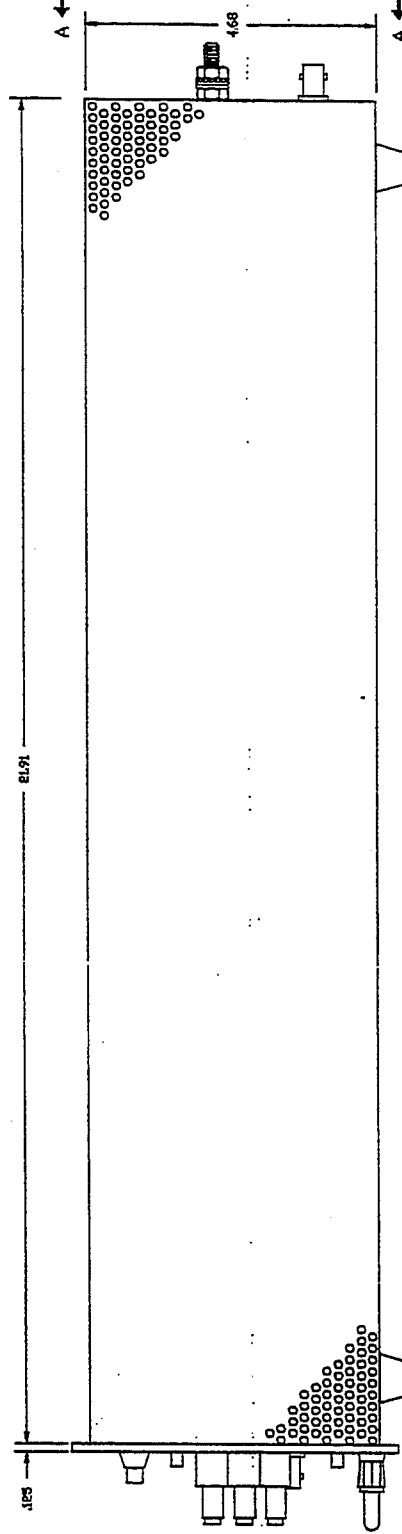
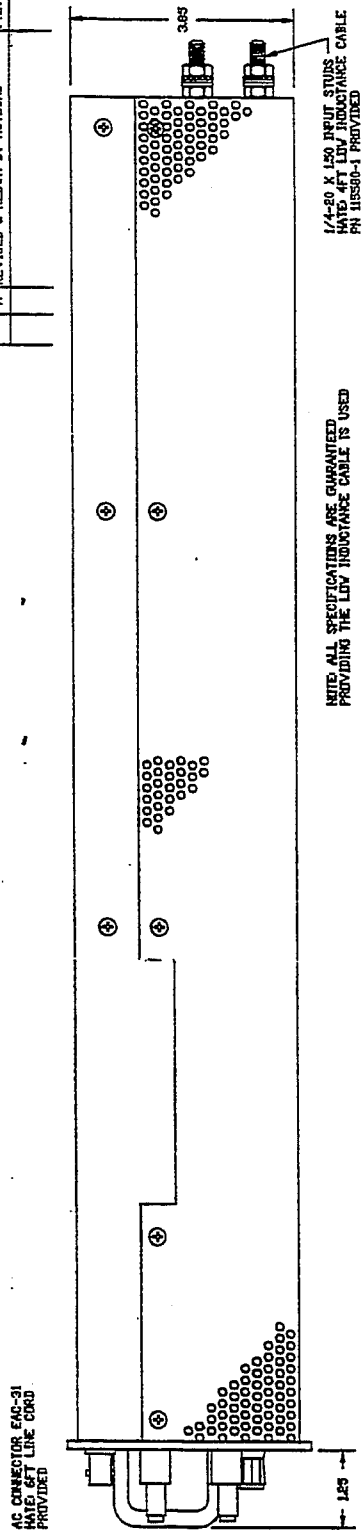

FIGURE 1. CALIBRATION SETUP



REV	DATE	DESCRIPTION	DESIGN
1			
PARTS LIST		TRANSMITTER	DEVICES INC
DRAWING TITLE		SCHEMATIC	
DATE	BY	CHECKED	APPROVED
09004			
119369			
09004			
119369			
09004			
119369			

ZONE/REV	DESCRIPTION	DATE	APP'D
A	REVISED & REDRAWN BY AUTOCAD	1 NOV 91	



VIEW A-A

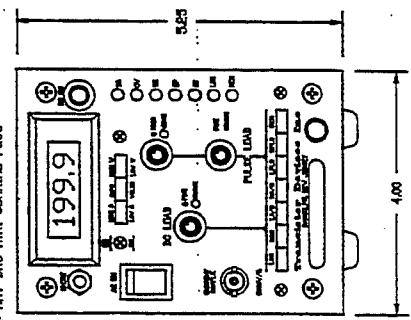

BNC CONNECTOR 31-10 HATED ANY BNC MINI COAXIAL PLUG

SWITCH FUNC.	MODEL NO.	DLF 100-50-250	DLF 400-50-250
LCC	5A	5A	5A
R2C	50A	50A	50A
LA/V	30A/V	150A/V	150A/V
HA/V	30A/V	150A/V	150A/V
L PLS	5A	5A	5A
H PLS	50A	50A	50A
PGH	PGH	PGH	PGH
SHRT	SHRT	SHRT	SHRT

NOTES:

1. DIMENSIONS ARE FOR ENGINEERING REF ONLY

CITY	COMP	CONTRACT NO.	DATE	NO. OF UNITS	DESCRIPTION	FORM NO.
					Transistor Devices Inc	
USER'S NAME & ADDRESS		COUNTRY		DRAWING TITLE		
TOLERANCES UNLESS OTHERWISE SPECIFIED		FRAC. DEC. (1/16) DEC. (1/100)		OUTLINE & INSTALLATION		
3 PLACE DECIMALS		3 PLACE DECIMALS		DATE		
4 PLACE DECIMALS		4 PLACE DECIMALS		SCALE		
MATERIAL		MATERIAL		SHEET		
DLF 400-50-250	DLF 100-50-250	DLF 250	DLF 250	119368		
NEXT ASSY		USED BY		APPLICATION		