

**60 Watt, 1/4 Rack
Linear Power Supplies**

The XT Series 60W programmable power supplies are designed for benchtop and portable applications requiring affordable, low noise and low ripple performance. Single output models may be configured into a standard package providing dual, triple or quad outputs for a custom configuration. Customer-installed rack adapters are available for all rackmount configurations.



Features

- ◆ **Voltage**
Six standard models with adjustable voltage ranges from 0-7 to 0-120 VDC and current levels from 0.5 to 6 amps
- ◆ **Modular Design**
Choice of single (XTS), dual (XTD), triple (XTT) and quad (XTQ) benchtop or rackmountable supplies
- ◆ **Input**
115 VAC, 60 Hz single phase input standard; optional inputs available
- ◆ **Displays**
 - Simultaneous digital displays of voltage and current on large, easy to read LEDs
 - Unique twin LED analog bar graphs show relative voltage and current levels
- ◆ **Protection and Safety**
 - Automatic crossover into voltage or current mode with overvoltage/overcurrent signal LED
 - No overshoot at turn-on, turn-off or power failure
- ◆ **Series or Parallel Operation**
- ◆ **Regulation**
0.02% line and load + 4 mV regulation
- ◆ **Transient Response**
100 µs transient response with ±50% load change (typical)
- ◆ **Ripple**
1.0 mV RMS ripple
- ◆ **Programming**
 - Analog programming and monitoring of output voltage and/or current, OVP, remote on/off, master/slave tracking (Option M5A)
 - High resolution 10-turn potentiometer provides precise output voltage control
 - Internal IEEE-488 Interface Card with voltage/current readback and adjustable OVP (Option M9B)
 - 10-turn current control potentiometer (Option M11)
- ◆ **CE Mark**
- ◆ **5 Year Warranty**



XT Series - Specifications

OUTPUT

Voltage and Current

Model	Voltage	Current
XTS 7-6	0-7	0-6
XTS 15-4	0-15	0-4
XTS 20-3	0-20	0-3
XTS 30-2	0-30	0-2
XTS 60-1	0-60	0-1
XTS 120-5	0-120	0-0.5

Constant Voltage Mode

Ripple: 1 mV RMS

Regulation: Line and load combined
0.02% of $V_{max} + 4$ mV

Transient Response: Typically recovers in 100 μ s to within 0.05% of steady-state output voltage. $\pm 50\%$ load change in the range of 25% to 100% of rated load

Stability: 0.02% of maximum voltage over 8 hours after 30 minute warm up time at fixed line, load and temperature

Temperature Coefficient: 0.02%/°C after 30 minute warm up

Constant Current Mode

Ripple: 2 mA RMS

Regulation: Line and load combined
0.02% of $I_{max} + 500$ μ A, over 10-100% of output range

Stability: 0.03% of maximum current over 8 hours after 30 minute warm up time at fixed line, load and temperature

Temperature Coefficient: 0.02/°C after 30 minute warm up

INPUT

Voltage and Frequency: 115 VAC $\pm 10\%$, 57-63 Hz, single phase (optional inputs available)

Current: 1.2A max

GENERAL

Operating Temperature: 0 to 70°C
(derated above 30°C)

Storage Temperature: -55°C to 85°C

Cooling: By convection

Efficiency: 43% typical

Series Operation: Outputs may be connected in series with no external protection

Parallel Operation: Outputs may be connected in parallel with no external protection

Remote Sensing: Compensates for maximum line drop of 500 mV (per output line)

Voltage Programming: Zero to full scale output linearly proportioned to a 0-10V or 0-10 k Ω (Option M5A)

Current Programming: Zero to full scale output linearly proportioned to 0-10V or 0-10 k Ω (Option M5A)

Overshoot: No overshoot at turn-on, turn-off or power failure

Overvoltage Protection: Available with optional M5A and M9B

Overload Short-Circuit Protection: Standard, switches to current mode operation while in short-circuit

Output to Chassis Isolation:
400 VDC max

Voltage Resolution: 0.02%

Meter Accuracy: 1% of full scale + 1 digit

Regulatory Compliance: CE
Mark on XTS only

Dimensions: 3U or 5.25" (133 mm) H x 4.25" (108 mm) W x 11.50" (292 mm) D

Weight:

XTS: 9.5 lbs. (4.3 kg)

XTD: 17.9 lbs. (6.1 kg)

XTT: 26.3 lbs. (12.0 kg)

XTQ: 36.7 lbs. (16.7 kg)

OPTIONS & ACCESSORIES

Power Input Modifications:

M1: 110V $\pm 10\%$, 47-63 Hz

M2: 220V $\pm 10\%$, 47-63 Hz

M3: 230V $\pm 10\%$, 47-63 Hz

M4: 240V $\pm 10\%$, 47-63 Hz

M5A Analog Programming: Internal interface for full scale remote programming of output voltage and/or current by a 0-10V or 0-10 k Ω external source connected at the rear panel. Includes 0-10V readback, externally adjustable offset and range, front panel adjustable overvoltage protection (OVP), TTL shutdown with selectable logic, master/slave tracking and status signals for programming mode, operating mode, OVP and output fail flag. (May not be combined with M9B)

M9B Internal IEEE-488 Interface: Features complete remote programming, including status reporting, settings query and interrupt generation with user designated fault conditions. Both the voltage and current output are precisely programmed directly in volts and amps. (May not be combined with M5A)

M11: 10-turn current control potentiometer

M13: Locking shafts (front panel potentiometer)



Rack Adapter Kit:
Specify RM-XHS

XT Series - Data Tables and J3 Assignments

Model	Output Power				Constant Voltage Mode					Voltage Drift % V ₀ Max. (Typ.)	Programming Constant Voltage Mode ³	
	Voltage (VDC)	Current (ADC) ¹			Regulation Line and Load mV	Ripple (RMS) mV	Resolution %	Transient Resonse Time ² μs	Temp. Coeff., Voltage mV/°C		Ohms/V	V/V
		30°C	40°C	50°C								
XTS 7-6	0-7	6	4.5	3	5.4	1	0.02	100	1.0	0.02	1429	0.7
XTS 15-4	0-15	4	3	2	7	1	0.02	100	2.2	0.02	667	1.5
XTS 20-3	0-20	3	2.25	1.5	8	1	0.02	100	3.0	0.02	500	2
XTS 30-2	0-30	2	1.15	1	10	1	0.02	100	4.5	0.02	333	3
XTS 60-1	0-60	1	0.75	0.5	16	1	0.02	100	9.0	0.02	167	6
XTS 120-5	0-120	0.5	0.375	0.25	28	1	0.02	100	18.0	0.02	83	12

Model	Constant Current Mode		Temp. Coeff., Current %/°C (Typ.)	Current Drift % ₀ Max. (Typ.)	Programming Constant Current Mode ³		Standard Input Power (Single Phase, 57-63 Hz)		Efficiency % (Typ.)
	Line and Load Regulation mA	Ripple (RMS) mA			Ohms/A	V/A	Voltage VAC ± 10%	Current AAC Max.	
XTS 7-6	1.7	2	0.02	0.03	1667	1.61	115	1.2	43
XTS 15-4	1.3	2	0.02	0.03	2500	2.4	115	1.2	43
XTS 20-3	1.1	2	0.02	0.03	3333	3.3	115	1.2	43
XTS 30-2	0.9	2	0.02	0.03	5000	4.2	115	1.2	43
XTS 60-1	0.7	2	0.02	0.03	10,000	5.1	115	1.2	43
XTS 120-5	0.6	2	0.02	0.03	20,000	6.05	115	1.2	43

Notes: 1. See detailed temperature derating charts. 2. Transient response rate for ±50% load change in range of 25-100% of rated load. 3. Only available with M5A option.

M5A: J-305 Pin Assignments

1	Overvoltage Protection Flag	14	Not Used
2	TTL Shutdown Return	15	TTL Shutdown
3	Not Used	16	Current Limit Program
4	Program Return	17	Voltage Program
5	Program Return	18	Current Readback
6	Auxiliary Ground	19	Voltage Readback
7	Remote Voltage Program Select*	20	+10V Reference Out (10 mA max.)
8	Remote Current Program Select*	21	Output Fail Flag*
9	Voltage Current Limit Mode Indicator	22	+ Sense
10	+ Out	23	+ Out
11	+ Out	24	- Return
12	- Return	25	- Sense
13	- Return		

XT Series - Case and Temperature Information

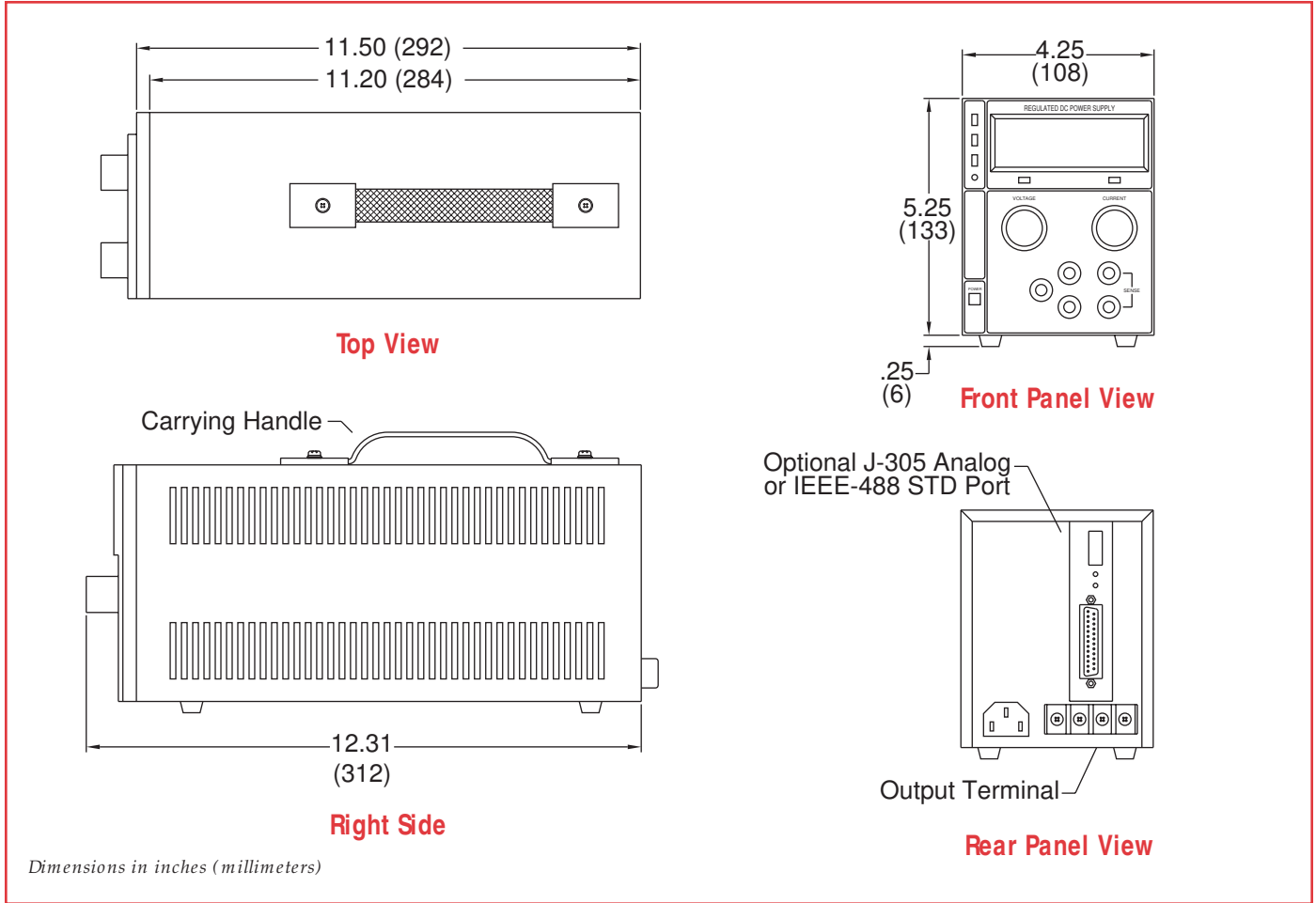

Temperature Derating Information

