



***DHP Series
DC Power Supplies***

**IEEE 488.2/RS-232 Options
Programming Manual**

**SORENSEN
Division of Elgar
9250 Brown Deer Road
San Diego, CA 92121-2294
1-800-733-5427
Tel: (858) 450-0085
Fax: (858) 458-0267
Email: sales@elgar.com
www.elgar.com**

©2002 by Sorensen, Division of Elgar Electronics Corporation
This document contains information proprietary to Sorensen, division of Elgar Electronics Corporation. The information contained herein is not to be duplicated or transferred in any manner without prior written permission from Sorensen.

July 29, 2002

Document No. M550005-01 Rev B

TABLE OF CONTENTS

Chapter 1 FEATURES, FUNCTIONS, and SPECIFICATIONS	1-1
1.1 Introduction	1-1
1.2 Features and Functions	1-1
1.3 Specifications	1-2
Chapter 2 CONFIGURATION	2-1
2.1 Setup Procedure	2-1
2.1.1 Address Selection	2-2
2.2 External User Control Signal Connector	2-3
2.3 Remote programming via RS-232	2-3
Chapter 3 IEEE 488.2 and SCPI COMMAND OPERATION	3-1
3.1 Introduction	3-1
3.2 IEEE-488.2 Register Definitions	3-1
3.2.1 Status Byte.....	3-1
3.2.2 Standard Event Status Register (ESR).....	3-3
3.2.3 Operation Status and Questionable Status Registers	3-4
3.2.4 Error/Event Queue	3-5
3.2.5 Serial Poll Operation	3-7
3.3 IEEE-488.2 and SCPI Conformance Information	3-8
3.3.1 Parameter Definitions	3-8
3.3.2 Units.....	3-8
3.3.4 Queries	3-8
3.4 IEEE-488.2 Common Command Subsystem	3-9
3.5 MEASURE SCPI Command Subsystem	3-11
3.5.1 MEASURE SCPI Command Summary.....	3-11
3.5.2 MEASURE SCPI Command Reference.....	3-11
3.6 OUTPUT SCPI Command Subsystem	3-11
3.6.1 OUTPUT SCPI Command Summary.....	3-11
3.6.2 OUTPUT SCPI Command Reference.....	3-11
3.7 SOURCE SCPI Command Subsystem	3-12
3.7.1 SOURCE SCPI Command Summary	3-12
3.7.2 SOURCE SCPI Command Reference	3-13
3.8 STATUS SCPI Command Subsystem	3-14
3.8.1 STATUS SCPI Command Summary	3-14
3.8.2 STATUS SCPI Command Reference	3-15
3.9 SYSTEM SCPI Command Subsystem	3-17
3.9.1 SYSTEM SCPI Command Summary.....	3-17
3.9.2 SYSTEM SCPI Command Reference.....	3-18
3.10 DIAGNOSTIC SCPI Command Subsystem	3-19

3.10.1 DIAGNOSTIC SCPI Command Summary	3-19
3.10.2 DIAGNOSTIC SCPI Command Reference	3-20
3.11 ABORT SCPI Command Subsystem.....	3-21
3.11.1 ABORT SCPI Command Summary	3-21
3.12 INITIATE SCPI Command Subsystem.....	3-21
3.12.1 INITIATE SCPI Command Summary.....	3-21
3.13 Legacy Compatibility Commands	3-22
3.14 Examples of Using the SCPI Commands	3-22

LIST OF FIGURES

Figure 2-1 Flow chart of the menus for SCPI setup.....	2-2
Figure 2-2 RS-232 Rear Panel DB-9 Connector Pinout.....	2-3

LIST OF TABLES

Table 2-1 Remote Mode Power-on Conditions	2-2
Table 3-1 Status Byte Description.....	3-2
Table 3-2 Standard Event Status Register Description.....	3-3
Table 3-3 Questionable Status Register Description	3-4
Table 3-4 Error/Event Queue	3-5
Table 3-5 Parameter Definitions	3-8
Table 3-6 Unit Definitions.....	3-8
Table 3-7 Common Command Subsystem	3-9
Table 3-8 Measure Commands.....	3-11
Table 3-9 Output Commands.....	3-11
Table 3-10 Source Commands	3-13
Table 3-11 Status Commands	3-15
Table 3-12 System Commands.....	3-18
Table 3-13 Diagnostic Commands.....	3-20
Table 3-14 Abort Command.....	3-21
Table 3-15 Initiate Command.....	3-21
Table 3-16 Legacy Commands	3-22

Chapter 1

FEATURES, FUNCTIONS, and SPECIFICATIONS

1.1 Introduction

The SCPI interface option enables you to operate your power supplies from a computer via the IEEE-488.2 GPIB and/or RS-232 interface, allowing full remote programming control and monitoring of your power supply. Multiple source control is supported by the SCPI IEEE-488 version allowing control of up to 30 power supplies. For manual operation refer to the DHP series user manual P/N 11-195-000-00

1.2 Features and Functions

Features

- 12-bit programming and 3 digit readback of voltage and current
- Programmable overvoltage protection with reset
- IEEE-488.2 and SCPI compliant command set
- Soft calibration
- Rear panel IEEE-488.2 and or RS-232 control interface
- Rear panel User Control Signal interface
- Front panel configuration

Programmable Functions

- Output voltage, current, and power
- Over voltage protection
- Output enable/disable
- Full calibration

Readback Functions

- Actual measured voltage and current
- Voltage and current settings
- Over voltage protection setting
- Actual AC input voltage
- Peak AC input voltage
- Actual inlet temperature
- Peak inlet temperature
- Status and Accumulated Status registers
- Programming error codes
- Fault codes
- Manufacturer, power supply model, and firmware version identification

1.3 Specifications

(SUBJECT TO CHANGE WITHOUT NOTICE)

Programming Resolution

Voltage:	0.3% of full scale
Current:	0.3% of full scale
Overvoltage Protection:	0.5% of full scale (full scale is 120% of max output voltage.)

Programming Accuracy

Voltage:	$\pm (0.1\% + 0.3\% \text{ of maximum output voltage})$
Current:	$\pm (0.3\% + 0.3\% \text{ of maximum output current})^*$
Overvoltage Protection:	$\pm (0.5\% + 0.5\% \text{ of max output voltage})$

Readback Resolution

Voltage and Current:	$\pm 0.3\% \text{ of full scale}$
----------------------	-----------------------------------

Readback Accuracy

Voltage:	$\pm (0.1\% + 0.3\% \text{ of full scale})^*$
Current:	$\pm (0.3\% + 0.3\% \text{ of full scale})^*$

* After 30 minutes operation with fixed line, load, and temperature.

Chapter 2

CONFIGURATION

The SCPI option is installed in the supply at the factory. Use the Setup Procedure described below to configure the installed SCPI for your system and application.

2.1 Setup Procedure

STEP	DESCRIPTION
-------------	--------------------

- | | |
|-----|---|
| 1. | Press the MENU key until the <i>Control Source</i> selection is reached. |
| 2. | Use the UP ARROW or DOWN ARROW key to select SCPI. |
| 3. | Press the ENTER key. |
| 4. | Press the MENU key until the <i>SCPI Control Options</i> selection is reached (see Figure 2-1). |
| 5. | Press the ENTER Key. |
| 6. | Use the UP ARROW or DOWN ARROW key to select either GPIB IEEE-488 interface or SERIAL RS-232 interface. (On supplies without GPIB IEEE-488 installed, this option will not appear). |
| 7. | Press the ENTER key. |
| 8. | If SERIAL RS-232 was selected skip to step 14. |
| 9. | Use the UP ARROW or DOWN ARROW key to select the primary address, this address may be in the range of 0 to 30. |
| 10. | Press the ENTER key. |
| 11. | Use the UP ARROW or DOWN ARROW key to select the secondary address, this address may be in the range of 0 to 30. |
| 12. | Press the ENTER key. |
| 13. | Skip to step 16. |
| 14. | Use the UP ARROW or DOWN ARROW key to select the baud rate, this may be in the range of 300 to 19,200 baud. |
| 15. | Press the ENTER key. |
| 16. | Verify that the green REMOTE LED on the front panel is on. |
| 17. | Send a command via the selected interface to verify proper operation (i.e. : *IDN? This command string returns the power supply model and firmware version and does not affect the output). |

Figure 2-1
Flow chart of the menus for SCPI setup

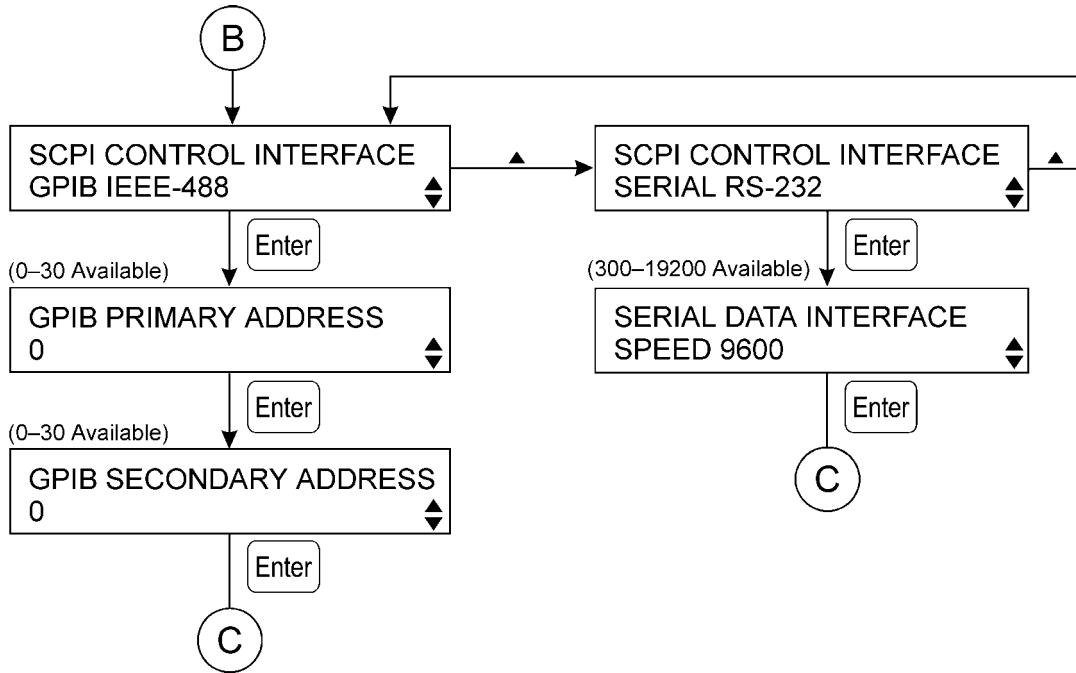

Powering up in remote mode will result in the operating conditions shown in Table 2-1.

Table 2-1
Remote Mode Power-on Conditions

Condition	Default
Voltage	0.0 Volts
Current	0.0 Amps
OVP Trip Voltage	Model maximum voltage + 10%
Output	ON
Service Request Capability	OFF

2.1.1 Address Selection

The address selection for a master unit is the GPIB address of that device (1-30). The address selection for an auxiliary unit is the channel number of that device (2-31). The channel selections 0 and 1 are invalid for an auxiliary device because SCPI reserves channel 0 as the global channel to address all channels and channel 1 as the default master channel to address the master unit. Selecting a secondary address of 0 causes the controller to use only the primary address. *A secondary address of 0 is the recommended operating mode.*

2.2 External User Control Signal Connector

The 25-pin connector located at the rear panel provides external auxiliary control signals to increase the user's operating control of the supply

WARNING

Please refer to the DHP manual, P/N 11-195-000-00 for further information. It is not recommended that any of the sense be changed if the power supply output is greater than zero volts or zero amps.

2.3 Remote programming via RS-232

The RS-232 interface operates at up to 19,200 baud with 8 data bits, no parity, and 1 stop bit. All SCPI commands are supported at the RS-232 interface with the exception of the Service Request (SRQ) function which is a GPIB-specific function requiring the dedicated Service Request line of the IEEE-488.2 interface. In this case, the SRQ function has no effect. The RS-232 interface is accessible through the rear panel DB-9 connector J2.

Figure 2-2
RS-232 Rear Panel DB-9 Connector Pinout

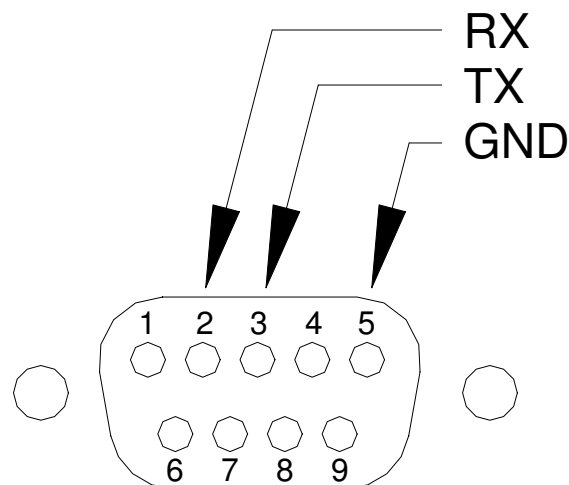

Chapter 3

IEEE 488.2 and SCPI COMMAND OPERATION

3.1 Introduction

The following sections describe the operation of the SCPI by remote programming using the SCPI IEEE488.2 and SCPI command set. The SCPI IEEE488.2 and SCPI command set of programming, query, and status commands allow control of the power supply.

3.2 IEEE-488.2 Register Definitions

The SCPI supports the IEEE-488.2 and SCPI 1995.0 status reporting data structures. These structures are comprised of status registers and status register enable mask pairs. The following sections describe these pairs.

3.2.1 Status Byte

The Status Byte status register can be read by the *STB? command or by issuing a GPIB serial poll. Either operation will clear the contents of the Status byte. The Status Byte status register will also be cleared by the *CLS command.

The SCPI can be configured to request service from the GPIB controller by setting the appropriate bits in the Service Request Enable Register (SRE). The SRE register has the same bit pattern as the Status Byte. It is modified using the *SRE <mask> command and read with the *SRE? command. For example, if the SRE register is set to 0x10 (MAV), when the SCPI unit has a message available, the Status Byte register will contain 0x50 (RQS and MAV) and the SRQ line of the GPIB bus will be asserted to indicate a request for service.

Table 3-1
Status Byte Description

Bit	Hex Value	Description
0	0x01	Not Used
1	0x02	Not Used
2	0x04	Error/event queue message available. Set when any error/event is entered in the System Error Queue. It is read using the SYSTem:ERRor? query.
3	0x08	Questionable Status flag. Indicates the quality of the current data being acquired. See questionable status register.
4	0x10	Message available (MAV). Indicates a message is available in the GPIB output queue. Cleared after the GPIB output buffer is read.
5	0x20	Standard Event Status Register (ESR). Summary bit for the ESR. Set when any of the ESR bits are set and cleared when the ESR is read.
6	0x40	Request Service flag (RQS) for serial polling or Master Summary Status (MSS) in response to *STB?. If service requests are enabled (with the *SRE command), this bit represents the RQS and will be sent in response to a serial poll, then cleared. If RQS is not enabled, the bit represents the MSS bit and indicates the device has at least one reason to request service. Even though the device sends the MSS bit in response to a status query (*STB?), it is not sent in response to a serial poll. It is not considered part of the IEEE-488.1 Status Byte.
7	0x80	Operation Status flag. Indicates the current operational state of the unit. See operation status register.

3.2.2 Standard Event Status Register (ESR)

The Standard Event Status Register (ESR) can be read by the *ESR? command. Reading this register or the *CLS command will clear the ESR. Bits in the ESR will only be set when the corresponding bit in the Standard Events Status Enable Register is set. Use the *ESE <mask> to set bits, and the *ESE? to read this register. To configure the DCS Series SCPI to generate GPIB service requests based on the ESR, both the Standard Event Status Enable Register and the Service Request Enable Register must be programmed.

Table 3-2
Standard Event Status Register Description

Bit	Hex Value	Description
0	0x01	Operation Complete.
1	0x02	Request Control - not used.
2	0x04	Query Error.
3	0x08	Device Dependent Error – not used.
4	0x10	Execution Error (e.g. range error)
5	0x20	Command Error (e.g. syntax error)
6	0x40	User Request - not used.
7	0x80	Power On

3.2.3 Operation Status and Questionable Status Registers

The Operation Status and Questionable Status Registers are defined in the tables below. Both of these registers are read-only registers.

Table 3-3
Questionable Status Register Description

Bit	Hex Value	Description
0	0x0001	Not Regulating at Voltage Limit
1	0x0002	Not Regulating at Current Limit
2	0x0004	Time (Unused)
3	0x0008	Not Regulating at Power Limit
4	0x0010	Set on Temperature Fault
5	0x0020	Frequency (Unused)
6	0x0040	Phase (Unused)
7	0x0080	Modulation (Unused)
8	0x0100	Set if not Power Supply Not Calibrated
9	0x0200	Set when AC Input Fault
10	0x0400	Set when Module Fault
11	0x0800	Set when OVP Protection Tripped
12	0x1000	(Unused)
13	0x2000	(Unused)
14	0x4000	(Unused)
15	0x8000	(Unused)

OPERATION STATUS REGISTER		
Bit	Hex Value	Description
0	0x0001	Calibrating (Unused)
1	0x0002	Setting (Unused)
2	0x0004	Ranging (Unused)
3	0x0008	Sweeping (Unused)
4	0x0010	Measuring (Unused)
5	0x0020	Waiting for trigger summary (Unused)
6	0x0040	Waiting for ARM summary (Unused)
7	0x0080	Correcting (Unused)
8	0x0100	Remote off
9	0x0200	Remote Voltage Mode
10	0x0400	Remote Current Mode
11	0x0800	(Unused)
12	0x1000	(Unused)
13	0x2000	(Unused)
14	0x4000	(Unused)
15	0x8000	(Unused)

3.2.4 Error/Event Queue

The SCPI maintains an Error/Event Queue as defined by SCPI. The queue holds up to 10 error and events. It is queried using the SYSTem:ERRor? command which reads in a First In/First Out (FIFO) manner. The read operation removes the entry from the queue. The *CLS command will clear all entries from the queue.

The following error codes are defined in the SCPI 1995.0 specification and are supported by the SCPI. Error codes are in the range of [-32768, 32767]. SCPI reserves the negative error codes and 0, while error codes greater than 0 are device specific errors.

Table 3-4
Error/Event Queue

Error	Description
-102	Syntax error
-104	Data type error
-105	GET not allowed
-108	Parameter not allowed
-109	Missing parameter
-110	Command Header Error
-111	Header Separator Error
-112	Program mnemonic too long
-113	Undefined header
-114	Header suffix out of range
-120	Numeric data error
-121	Invalid character in number
-123	Exponent too large
-124	Too many digits
-128	Numeric data not allowed
-130	Suffix error
-131	Invalid suffix
-134	Suffix too long
-138	Suffix not allowed
-140	Character data error
-141	Invalid character data
-144	Character data too long
-148	Character data not allowed
-150	String data error
-151	Invalid string data
-158	String data not allowed
-160	Block data error
-161	Invalid block data
-168	Block data not allowed
-170	Expression error
-171	Invalid expression
-178	Expression data not allowed
-180	Macro error

-181	Invalid outside macro definition
-183	Invalid inside macro definition
-184	Macro parameter error
-200	Execution error
-201	Invalid while in local
-202	Settings lost due to rtl
-210	Trigger error
-211	Trigger ignored
-212	Arm ignored
-213	Init ignored
-214	Trigger deadlock
-215	Arm deadlock
-220	Parameter error
-221	Settings conflict
-222	Data out of range
-223	Too much data
-224	Illegal parameter value
-230	Data corrupt or stale
-231	Data questionable
-240	Hardware error
-241	Hardware missing
-250	Mass storage error
-251	Missing mass storage
-252	Missing media
-253	Corrupt media
-254	Media full
-255	Directory full
-256	File name not found
-257	File name error
-258	Media protected
-260	Expression Error
-261	Math error in expression
-270	Macro error
-271	Macro syntax error
-272	Macro execution error
-273	Illegal macro label
-274	Macro parameter error
-275	Macro definition too long
-276	Macro recursion error
-277	Macro redefinition not allowed
-278	Macro header not found
-280	Program error
-281	Cannot create program
-282	Illegal program name
-283	Illegal variable name
-284	Program currently running
-285	Program syntax error
-286	Program runtime error
-300	Device-specific error

-310	System error
-311	Memory error
-312	PUD memory lost
-313	Calibration memory lost
-314	Save/recall memory lost
-315	Configuration memory lost
-330	Self-test failed
-350	Queue overflow
-400	Query error
-410	Query INTERRUPTED
-420	Query UNTERMINATED
-430	Query DEADLOCKED
-440	Query UNTERMINATED after indefinite response
201	Query only
202	No query allowed
203	Parameter(s) not expected
204	Constant not allowed in STATUS subsystem
207	Enumeric value not in union
208	Illegal number of parameters
210	Run out of memory handle
211	Unit not matched
212	Unit not required
213	Unit not valid

3.2.5 Serial Poll Operation

Performing a serial poll will not modify the Status Byte other than to clear the RQS (bit 6) for an SCPI requesting service. Queries affecting the Status Registers and subsequent serial poll are described below:

- *STB? clears the Status Byte
- *ESR? clears the ESR and bit 5 of the Status Register
- SYSTem:ERRor? clears bit 2 of the Status Register if the queue is empty

3.3 IEEE-488.2 and SCPI Conformance Information

The SCPI conforms to all specifications for devices as defined in IEEE-488.2 and complies with SCPI command syntax version 1995.0. Confirmed Commands are those commands which are approved commands in the SCPI 1995 Specification, Volume 2: Command Reference. They are denoted by a “C” in the “SCPI” column. Any commands that are not Confirmed Commands have been submitted to the SCPI Consortium and are labeled as Not Approved denoted by a “N”.

3.3.1 Parameter Definitions

Table 3-5
Parameter Definitions

Type	Valid arguments
<boolean>	“ON” or 1. “OFF” or 0.
<NR1>	The data format <NR1> is defined in IEEE-488.2 for integers. Zero, positive and negative integer numeric values are valid data.
<0+NR1>	Zero and positive integer numeric values.
<-NR1>	Negative integer numeric values.
<NRf>	The data format <NRf> is defined in IEEE-488.2 for flexible Numeric Representation. Zero, positive and negative floating point numeric values are some examples of valid data.
<0+NRf>	Zero and positive floating point numeric values.
<-NRf>	Negative floating point numeric values.
<string>	Characters enclosed by single or double quotes.

3.3.2 Units

The DCS Series SCPI will accept the following units as suffixes to numeric values:

Table 3-6
Unit Definitions

Type of Unit	Valid suffix
Voltage	“VOLTS” or “volts”, “V” or “v”
Current	“AMPS” or “amps”, “A” or “a”

3.3.4 Queries

The query syntax is identical to the command syntax with a “?” appended. For example, to query the programmed voltage, send the string: SOURce:VOLTage?. A subsequent device read will return a value such as “33.000”. All queries are terminated with a line feed (0x0A) for those GPIB controllers that require termination characters. When the SCPI has nothing to report, its output buffer will contain one ASCII characters: a linefeed (in decimal the value is: <10>).

3.4 IEEE-488.2 Common Command Subsystem

The following commands are common to all SCPI instruments and declared mandatory by IEEE-488.2. In the following table, the SCPI will be defined as the “device” on the GPIB bus.

Table 3-7
Common Command Subsystem

Command	Description
*CLS	Clears all status reporting data structures including the Status Byte, Standard Event Status Register, and Error Queue. Enable masks are not cleared.
*ESE <0+NR1>	Sets the value of the Standard Event Status Enable Register which determines which bits can be set in the Standard Event Status Register. See section on Standard Event Status Register for valid values.
*ESE?	Returns the integer value of the Standard Event Status Enable Register. See section on Standard Event Status Register for valid values. Response: <0+NR1>
*ESR?	Returns the integer value of the Standard Event Status Register. The ESR and the Status Byte ESR bit are cleared. See section on Standard Event Status Register for valid values. Response: <0+NR1>
*IDN?	Returns the device identification as an ASCII string. Response: <Manufacturer>, <model>, <serial number>, <firmware type, version, & datecode> Example: Sorensen,DHP10-1000,PTS Rev 2.18 19980601
*OPC	Enables the Operation Complete bit of the Standard Events Status Register to be set when all pending operations are complete. See section on Standard Event Status Register.
*OPC?	Returns the integer value “1” when all pending operations are complete. See section on Standard Event Status Register. Response: <0+NR1>
*RCL n	Recalls settings from memory. Memory numbers from 1 to 9 are valid. It can only be executed when the supply is Remote SCPI control mode. It recalls setting for Voltage Limit, Current Limit, Power Limit and Over Voltage Limit

Table 3-7
Common Command Subsystem (continued)

Command	Description
*RST	Resets the supply to its Power ON (PON) state. Clears all status reporting data structures including the Status Byte, Standard Event Status Register, and Error Queue. Enable masks are not cleared.
*SAV n	Saves current settings to memory. Memory numbers from 1 to 9 are valid. It can only be executed when the supply is Remote SCPI control mode. It saves setting for Voltage Limit, Current Limit, Power Limit and Over Voltage Limit
*SRE <0+NR1>	Sets the value of the Service Request Enable Register which determines which bits in the Status Byte will cause a service request from the device. See section on Status Byte for valid values.
*SRE?	Returns the integer value of the Service Request Enable Register. See section on Status Byte for valid values. Values range from 0-63 or 128-191. Response: <0+NR1>
*STB?	Returns the integer value of the Status Byte with bit 6 representing the Master Summary Status (MSS) instead of RQS. The MSS bit acts as a summary bit for the Status Byte and indicates whether or not the device has at least one reason to request service based on the MAV and the ESR bits. The Status Byte is cleared. See section on Status Byte for valid values. Values range from 0-255. Response: <0+NR1>
*TST?	Response: <0>
*WAI	Sets the device to wait until all previous commands and queries are complete before executing commands following the *WAI command.

3.5 MEASURE SCPI Command Subsystem

3.5.1 MEASURE SCPI Command Summary

```

MEASure[n]
    [:SCALar]
        :CURRent?
        :POWER?
        :VOLTage?
    
```

3.5.2 MEASURE SCPI Command Reference

Table 3-8
Measure Commands

Command	Description	SCPI
MEASure	Measure subsystem.	C
:CURRent?	Returns the floating point value of the DC output current in amps.	C
:POWER?	Returns the floating point value of the DC output power in watts.	C
:VOLTage?	Returns the floating point value of the DC output voltage in volts.	C

3.6 OUTPUT SCPI Command Subsystem

3.6.1 OUTPUT SCPI Command Summary

```

:OUTPut
    [:STATe]
    [:STATe]?
    
```

3.6.2 OUTPUT SCPI Command Reference

Table 3-9
Output Commands

Command	Description	SCPI
OUTPut		
[:STATe]	Set Power Supply Output Enable Control. This can only be executed when the supply is Remote SCPI control mode.	C
[:STATe]?	Queries the status of the Power Supply Output Enable Control.	C

3.7 SOURCE SCPI Command Subsystem

3.7.1 SOURCE SCPI Command Summary

```
[SOURce]:[n]
  :CURRent
    [:LEVel]
      [:IMMediate]
        [:AMPLitude]
        [:AMPLitude]?
      :TRIGgered
        [:AMPLitude]
        [:AMPLitude]?
  :POWer
    [:LEVel]
      [:IMMediate]
        [:AMPLitude]
        [:AMPLitude]?
      :TRIGgered
        [:AMPLitude]
        [:AMPLitude]?
  :VOLTage
    [:LEVel]
      [:IMMediate]
        [:AMPLitude]
        [:AMPLitude]?
      :TRIGgered
        [:AMPLitude]
        [:AMPLitude]?
  :PROTection
    :CLEar
    [:LEVel]
    [:LEVel]?
    :TRIPped?
```

3.7.2 SOURCE SCPI Command Reference

Table 3-10
Source Commands

Command	Description	SCPI
SOURce	Source subsystem. n = 1-31. The default channel is 1.	C
:CURRent	Sets the output current in	C
[:LEVel]	Sets the output current in amps	C
[:IMMediate]	Sets the output current in amps	C
[:AMPLitude]	Sets the output current in amps	C
[:AMPLitude]?	Reads the output current in amps	C
:TRIGgered		
[:AMPLitude]	Sets the output current in amps for later trigger	
[:AMPLitude]?	Reads the output current setpoint amps	C
:POWer	Sets the output power in watts.	C
[:LEVel]	Sets the output power in watts.	C
[:IMMediate]	Sets the output power in watts.	C
[:AMPLitude]	Sets the output power in watts.	C
[:AMPLitude]?	Reads the output power in watts.	C
:TRIGgered		
[:AMPLitude]	Sets the output power in watts for later trigger	
[:AMPLitude]?	Reads the output power setpoint in amps	C
:VOLTage	Sets the output voltage of the supply in volts.	C
[:LEVel]	Sets the output voltage in volts.	C
[:IMMediate]	Sets the output voltage in volts.	C
[:AMPLitude]	Sets the output voltage in volts.	C
[:AMPLitude]?	Reads the output voltage in volts.	C
:TRIGgered		
[:AMPLitude]	Sets the output voltage in volts for later trigger	
[:AMPLitude]?	Reads the output voltage setpoint in amps	C
:PROTection	Sets the over voltage protection trip point in volts.	C
:CLEar	Resets the overvoltage circuit allowing the power supply to run.	
[:LEVel]	Sets the over voltage protection trip point in volts.	C
[:LEVel]?	Returns the over voltage protection trip set point in volts.	C
:TRIPped?	Returns the integer value 1 (TRIPPED) or 0 (UNTRIPPED) state of the over voltage protection.	C

3.8 STATUS SCPI Command Subsystem

3.8.1 STATUS SCPI Command Summary

STATus[n]
 :OPERation
 :CONDition?
 :ENABle
 :ENABle?
 :EVENT?
 :PRESet
 :QUEStionable
 :CONDition?
 :ENABle
 :EVENT?

3.8.2 STATUS SCPI Command Reference

Table 3-11
Status Commands

Command	Description	SCPI																																
STATus	Status subsystem.	C																																
:OPERation		C																																
:CONDition?	<p>Query the Operation Condition Register. A change from 0 to 1 of this condition register sets the corresponding bit of the Operation Event register. The bits in the Operation Condition register by bit position(weight) are:</p> <table> <tr> <td>0(1)</td> <td>Calibrating (Unused)</td> </tr> <tr> <td>1(2)</td> <td>Setting (Unused)</td> </tr> <tr> <td>2(4)</td> <td>Ranging (Unused)</td> </tr> <tr> <td>3(8)</td> <td>Sweeping (Unused)</td> </tr> <tr> <td>4(16)</td> <td>Measuring (Unused)</td> </tr> <tr> <td>5(32)</td> <td>Waiting for Trigger (Unused)</td> </tr> <tr> <td>6(64)</td> <td>Waiting for Arm (Unused)</td> </tr> <tr> <td>7(128)</td> <td>Correcting (Unused)</td> </tr> <tr> <td>8(256)</td> <td>Remote OFF asserted</td> </tr> <tr> <td>9(512)</td> <td>Remote Analog Voltage Programming mode</td> </tr> <tr> <td>10(1024)</td> <td>Remote Analog Current Programming mode</td> </tr> <tr> <td>11(2048)</td> <td>(Unused)</td> </tr> <tr> <td>12(4096)</td> <td>(Unused)</td> </tr> <tr> <td>13(8192)</td> <td>(Unused)</td> </tr> <tr> <td>14(16384)</td> <td>Auto Step Program Running</td> </tr> <tr> <td>15(32768)</td> <td>Reserved - Never Set</td> </tr> </table>	0(1)	Calibrating (Unused)	1(2)	Setting (Unused)	2(4)	Ranging (Unused)	3(8)	Sweeping (Unused)	4(16)	Measuring (Unused)	5(32)	Waiting for Trigger (Unused)	6(64)	Waiting for Arm (Unused)	7(128)	Correcting (Unused)	8(256)	Remote OFF asserted	9(512)	Remote Analog Voltage Programming mode	10(1024)	Remote Analog Current Programming mode	11(2048)	(Unused)	12(4096)	(Unused)	13(8192)	(Unused)	14(16384)	Auto Step Program Running	15(32768)	Reserved - Never Set	C
0(1)	Calibrating (Unused)																																	
1(2)	Setting (Unused)																																	
2(4)	Ranging (Unused)																																	
3(8)	Sweeping (Unused)																																	
4(16)	Measuring (Unused)																																	
5(32)	Waiting for Trigger (Unused)																																	
6(64)	Waiting for Arm (Unused)																																	
7(128)	Correcting (Unused)																																	
8(256)	Remote OFF asserted																																	
9(512)	Remote Analog Voltage Programming mode																																	
10(1024)	Remote Analog Current Programming mode																																	
11(2048)	(Unused)																																	
12(4096)	(Unused)																																	
13(8192)	(Unused)																																	
14(16384)	Auto Step Program Running																																	
15(32768)	Reserved - Never Set																																	
:ENABle	Sets the enable mask of the Operation Event Register allowing true conditions to be reported in the summary bit of the Operation Condition Register. Values are written and queried but have no effect on the Operation Condition Register.	C																																
:ENABle?	Query the value of the Operation Event Enable register. (see STATus:OPERation:CONDition? for bit definitions)	C																																

Table 3-11
Status Commands (continued)

Command	Description	SCPI
STATus	Status subsystem	C
:OPERation		C
:EVENT?	Query the Operation Event register. This operation also clears this register. (see STATus:OPERation:CONDition? for bit definitions)	C
:PRESet	Clears all bits in :STATus:OPERation:ENABLE and STATus:QUESTionable:ENABLE	C
:QUESTionable		C
:CONDition?	<p>Query the Questionable Condition Register. A change from 0 to 1 of this condition register sets the corresponding bit of the Questionable Event register. The bits in the Questionable Condition register by bit position(weight) are:</p> <p>0(1) Not regulating at Voltage Limit</p> <p>1(2) Not regulating at Current Limit</p> <p>2(4) Time (Unused)</p> <p>3(8) Not regulating at Power Limit</p> <p>4(16) Over Temperature condition exists</p> <p>5(32) Frequency (Unused)</p> <p>6(64) Phase (Unused)</p> <p>7(128) Modulation (Unused)</p> <p>8(256) Not Calibrated</p> <p>9(512) AC Line input out of operating range</p> <p>10(1024) Module fault(s) exist</p> <p>11(2048) Over Voltage Protection tripped</p> <p>12(4096) (Unused)</p> <p>13(8192) Instrument Summary (Unused)</p> <p>14(16384) Command Warning (Unused)</p> <p>15(32768) Reserved - Never Set</p>	C

Table 3-11
Status Commands (continued)

Command	Description	SCPI
STATus	Status subsystem. n = 1-31. The default channel is 1.	C
:QUEStionable		C
:ENABle	Set the Questionable Event Enable register. This is a mask register for the Questionable Event register. When a bit in the Questionable Event register is set and the corresponding bit in the Opeartion Event Enable register is a 1 then the Questionable Event Summary Bit of the Status Register is set.	C
:ENABle?	Query the value of the Questionable Event Enable register. (see STATus:QUEStionable:CONDition? for bit definitions)	C
[:EVENT]?	Query the Questionable Event register. This operation also clears this register. (see STATus:QUEStionable:CONDition? for bit definitions)	
:CONDition?		C

3.9 SYSTEM SCPI Command Subsystem

3.9.1 SYSTEM SCPI Command Summary

:SYSTem
:ERRor?
:VERSion?

3.9.2 SYSTEM SCPI Command Reference

Table 3-12
System Commands

Command	Description	SCPI
SYSTem	System subsystem.	C
:ERRor?	Queries Error Queue for next error/event entry (first in, first out). Entries conatins an error number and descriptive text. A 0 return value indicates no error occurred; negative numbers are reserved by SCPI. The maximum return string length is 255 characters. The queue holds up to 10 error/entries. All entries are cleared by the *CLS command.	C
:VERSion?	Returns a numeric value corresponding to the SCPI version number for which the instrument complies. The response is in the format YYYY.V where the Y's represent the year and V represents the approved version number for that year. e.g. 1995.0	C

3.10 DIAGNOSTIC SCPI Command Subsystem

3.10.1 DIAGNOSTIC SCPI Command Summary

```
:DIAGnostic
  :FAULts
    :CODE?
    :CONTRoller?
    :MAINinput
      :ACHigh?
      :ACLow?
    :MODule?
    :TEMPerature?
    :WATChdog?
  :DISPlay
    :INDicator?
    :SCReen?
  :KEYSend
    M
    L
    V
    C
    O
    0-9
    X
    +
    -
    E
  :TEMPerature
    :MAXimum?
    :IMMediate?
  :TIME
    :CALibrate?
    :OPERating?
  :VOLTage
    :MAINinput
      :MAXimum?
      :IMMediate?
```

3.10.2 DIAGNOSTIC SCPI Command Reference

Table 3-13
Diagnostic Commands

Command	Description	SCPI
:DIAGnostic		N
:FAULts		N
:CODE?	Queries last controller fault code stored.	N
:CONTRoller?	Queries controller fault count.	N
:MAINinput		N
:ACHigh?	Queries AC input high fault count.	N
:ACLow?	Queries AC input low fault count.	N
:MODUle?	Queries module fault counts. This returns in integer per module and ending with the third.	N
:TEMPerature?	Queries over temperature fault count.	N
:WATChdog?	Queries watchdog fault counts.	N
:DISPlay		N
:INDicator?	Queries status of the four indicator lights on the front panel. Returns a 1 or 0 for each LED indicator. The order of values returned is Constant Voltage LED, Constant Current LED, Constant Power LED, and Remote LED.	N
:SCReen?	Queries status of the Front panel screen. Returns two strings, one for each line of the display. Each line is 24 characters (including blanks).	N
:KEYSend	Allows the user to send keystrokes as if front panel keys were pressed. The argument is one or more characters (to a maximum of 7 characters) in a quoted string. The character that can be used are: M MENU L LAST SET V VOLTAGE C CURRENT O OVERVOLT 0-9 0-9 X CANCEL + + (UP) - - (DOWN) E ENTER	N

Table 3-13
Diagnostic Commands (continued)

Command	Description	SCPI
:DIAGnostic		N
:TEMPerature		N
:MAXimum?	Queries maximum ambient temperature recorded.	N
:IMMEDIATE?	Queries current ambient temperature.	N
:TIME		N
:CALibrate?	Queries time since last calibration (operating hours).	N
:OPERating?	Queries total operating hours.	N
:VOLTage		N
:MAINinput		N
:MAXimum?	Queries maximum AC input voltage recorded.	N
:IMMEDIATE?	Queries current AC input voltage.	N

3.11 ABORT SCPI Command Subsystem

3.11.1 ABORT SCPI Command Summary

:ABORT

Table 3-14
Abort Command

Command	Description	SCPI
:ABORT	About a triggered command sequence	Y

3.12 INITIATE SCPI Command Subsystem

3.12.1 INITIATE SCPI Command Summary

:INITiate

Table 3-15
Initiate Command

Command	Description	SCPI
:INITiate	Trigger command for voltage, current and power triggered commands	Y
[:IMMEDIATE]	Trigger command for voltage, current and power triggered commands	Y

3.13 Legacy Compatibility Commands

The following commands are included for compatibility with older software only and should not be used for new software. These commands are not part of the SCPI protocol.

Table 3-16
Legacy Commands

Command	Description
:RCA?	Query actual current reading.
:RVA?	Query actual voltage reading.
:SRCT	Ignored
:SRVT	Ignored
:WCA	Set current limit.
:WVA	Set voltage limit.

3.14 Examples of Using the SCPI Commands

The following examples demonstrate programming a power supply to control and to readback the output using the SCPI commands. The maximum voltage and current output is dependent on the particular model. The examples list only the SCPI commands; the code required to send the commands is dependent on the type of language you are using (e.g., C or BASIC) and GPIB hardware (e.g., National Instruments).

EXAMPLE: Program a unit with no load at the output to 5 VDC @ 1 A, and verify the output.

```
// Use SYST:ERR? after each command to verify no programming errors.
// power-on the unit.
*CLS // clear the unit to its power-on default settings.
*RST // reset the unit.
SOUR:CURR 1.0 // program output current to 1.0 A.
SOUR:CURR? // confirm the output current setting (response: 1.0).
SOUR:VOLT 5.0 // program output voltage to 5.0 VDC.
SOUR:VOLT? // confirm the output voltage setting (response: 5.0).
MEAS:CURR? // measure the actual output current (response: ~ 0.0).
MEAS:VOLT? // measure the actual output voltage (response: ~ 5.0).
```

EXAMPLE: Program a unit with no load at the output to generate a GPIB service request upon an over voltage protection trip condition. (Must use GPIB not RS-232.)

```
// Use SYST:ERR? after each command to verify no programming errors.
// assure that PON is not selected on the rear panel switch
// and the front panel SRQ led is OFF. Power-on the unit.
*CLS // clear the unit to its power-on default settings.
*RST // reset the unit.
SOUR:VOLT:PROT 4.0 // program the OVP trip point to 4.0 VDC.
SOUR:VOLT:PROT? // confirm the OVP trip point setting (response: 4.0).
SOUR:CURR 1.0 // program output current to 1.0 A.
SOUR:VOLT 3.0 // program output voltage to 3.0 VDC.
*SRE 2 // enable the GPIB service request upon a fault.
*SRE? // confirm the GPIB service request enabled (response 2).
SOUR:VOLT 7.0 // program output voltage to 7.0 VDC - cause OVP trip!
// confirm that OVP led and SRQ led is active, and unit issued a GPIB service request
// (use a serial poll).
```