

# 5kW and 10kW Three Phase Programmable Power Supplies DCR-T Series

DCR-T Series 5 and 10 kW high power programmable power supplies are specifically designed to meet today's requirement for the high power burn-in market. The DCR-T Series provides EMI-protected AC line, 0.1% line and load regulation (typical), and features full remote control, full remote monitoring, OVP shutdown, phase loss, and thermal shutdown. Digital meters are standard. All features are available under remote control or remote readback.

- 19 models, 0-4 to 0-600 Vdc and 8 to 800 A dc, thyristor-controlled and dc regulated
- 208 Vac, 60 Hz, 3 phase input (5 kW units); 480 Vac, 60 Hz, 3 phase input (10 kW units). Optional inputs available
- Automatic V/I crossover with indicators
- Remote control functions, i.e., V/I, OVP shutdown; external meter/indicator drive
- No programming resistors in contact with output, avoids hi-voltage problems with programming components
- EMI protection on ac line
- OVP shutdown standard
- 0.1% line and load regulation (typical)
- 30-150 mV RMS ripple (model dependent)
- 40 ms transient response—50% change (typical)
- Rear panel connector features: ac control, shutdown, voltage set, current set, OVP set, local/remote I meter, remote E meter, OVP indication, thermal/phase indication, remote sense
- SCR crowbar (Option M5)
- IEEE-488 Interface: talk/listen with V/I readback and adjustable OVP – external chassis for 5 kW units; Option M9A for 10 kW units
- 5 year warranty

## Sophisticated Controls For High Power Burn-In



5 kW Model

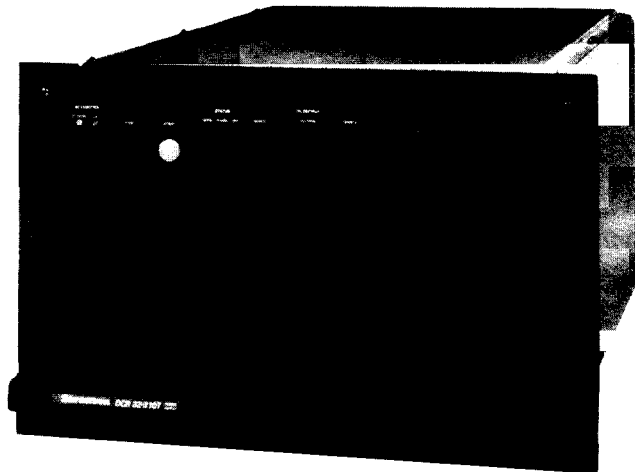

10 kW Model

# DCR-T Series Specifications

## DC OUTPUT

### CONSTANT VOLTAGE MODE

#### Voltage Regulation:

Line and load combined:  
All models 0.1% of the voltage setting or specification in table, whichever is greater.

#### Temperature Coefficient:

0.02%/°C of  $E_0$  max.

#### Voltage Programming:

100 mV per 1% of rated output. (0-10V for 0-100% of rated output.)

#### Resistive Programming:

100Ω per 1% of rated output. (0-10 kΩ for 0-100% of rated output.)

#### Stability:

0.1%  $E_0$  max. for 8 hours after 30 minute warm up with fixed line, load and temperature.

#### Remote sense:

3 to 10V max. drop, + line. 0.75V max. drop, - line.

#### Transient Response:

40 ms (typical) to return to ± 1% band for a step load change of 50% to 100%

or 100% to 50% of full load.

### CONSTANT CURRENT MODE

#### Current Regulation:

Line and load combined:  
All models 0.1%  $I_0$  max. of the output current setting or specification in table, whichever is greater.

#### Temperature Coefficient:

0.04%/°C of  $I_0$  max.

#### Current Programming:

100 mV per 1% of rated output. (0-10V for 0-100% of rated output.)

#### Resistive Programming:

100Ω per 1% of rated output. (0-10 kΩ for 0-100% of rated load.)

#### Stability:

0.2%  $I_0$  max. for 8 hours after 30 minute warm up with fixed line, load and temperature.

## INPUT

### Voltage:

480 Vac ± 10%, 60 Hz, three-phase, 10 kW models. 208 Vac ± 10%, 60 Hz, three-phase, 5 kW models.

### Voltage Options:

See chart on the next page.

### Frequency:

60 Hz all models. 50 Hz available as an option.

## OPERATING DATA

### Efficiency:

58%-67% of full rated output, depending on model.

### Series Operation:

200 Vdc maximum; consult Sorensen for series operation of more than 2 units.

### Parallel Operation:

Direct paralleling of any number of units.

### Overvoltage Protection:

Standard.

### Ambient Operating Temperature Range:

0 to +70°C.

### Storage Temperature Range:

-45°C to +85°C

### Cooling:

Forced air.

Model*	Output Power				Constant Voltage Mode						Temp. Coeff., Voltage mV/°C	Voltage Drift, % $E_0$ Max. (Typ.)	Programming Constants Voltage Mode	
					Regulation Line and Load mV <sup>1</sup>	Ripple (PARD)		Resolution	Transient Response Time ms (Typ.)					
	Voltage (Vdc)	Current (A dc)				mV RMS	mV P-P							
DCR 4-800T*	0-4	800	680	440	2-4	30	100	.025%	40	1.0	.05	2500	2.5	
DCR 8-400T*	0-8	400	340	220	4-8	30	100	.025%	40	2.0	.05	1250	1.25	
DCR 16-310T*	0-16	310	266	188	8-16	30	100	.025%	40	3.2	.05	625	.625	
DCR 16-625T**	0-16	625	531	375	8-16	30	100	.025%	40	3.2	.05	625	.625	
DCR 32-155T*	0-32	155	132	93	16-32	20	120	.025%	40	6.4	.05	313	.312	
DCR 32-310T**	0-32	310	264	186	16-32	20	120	.025%	40	6.4	.05	313	.312	
DCR 40-300T**	0-40	300	255	178	20-40	20	120	.025%	40	6.4	.05	250	.25	
DCR 55-90T*	0-55	90	74	54	27-55	20	120	.025%	40	11.0	.05	182	.18	
DCR 55-180T**	0-55	180	153	108	27-55	20	120	.025%	40	11.0	.05	182	.18	
DCR 80-62T*	0-80	62	54	37	40-80	20	120	.025%	40	16.0	.05	125	.125	
DCR 80-125T**	0-80	125	106	75	40-80	20	120	.025%	40	16.0	.05	125	.125	
DCR 110-45T*	0-110	45	38	27	55-110	40	140	.025%	40	22.0	.05	91	.09	
DCR 110-90T**	0-110	90	77	54	55-110	40	140	.025%	40	22.0	.05	91	.09	
DCR 160-30T*	0-160	30	27	18	80-160	60	180	.025%	40	32.0	.05	63	.063	
DCR 160-62T**	0-160	62	53	37	80-160	60	180	.025%	40	32.0	.05	63	.063	
DCR 300-16T*	0-300	16	14	10	150-300	100	300	.025%	40	60.0	.05	33	.033	
DCR 300-33T**	0-300	33	28	20	150-300	100	300	.025%	40	60.0	.05	33	.033	
DCR 600-8T*	0-600	8	7	4.8	300-600	150	600	.025%	40	120.0	.05	17	.0167	
DCR 600-16T**	0-600	16	14	9.6	300-600	150	600	.025%	40	120.0	.05	17	.0167	

\*Refer to the voltage option chart on the next page. \*\*Refer to the voltage option chart on the next page.

NOTES: 1. Regulation range as stated 0.1% of voltage or current, or stated range, whichever is greater. 2. Line current at min. line voltage. 3. Efficiency taken at max. power out and nominal ac volts input. 4. Part no. requires suffix (T1, T2 etc.) to specify ac power input option. See "VOLTAGE OPTIONS" table on page 23.

# DCR-T Series Specifications

## DCR-T ACCESSORIES

**Chassis Slide Kit:**  
Part No. 1060247-1

## OPTIONS

**M5:** SCR Crowbar

**External IEEE Interface Chassis for 5 kW units:**  
See Parallel Interface Controller (below).

**M9A Internal IEEE Interface for 10 kW units:**  
Features 14-bit resolution of programming and readback of voltage and current. The built-in DVM and current shunt measures the actual power supply output, providing accurate 12-bit readback. See pages 46-48 for more information.

## VOLTAGE OPTIONS

**Specifying Note:** Select ac input voltage option below, and add as a part no. suffix to specify power suppliers.

\$250 per option. N/C for option T1 on 5 kW. N/C for option T5 on 10 kW.

\* T1—208 Vac. 60 Hz (N/C)    T4—440 Vac. 60 Hz    T8—220 Vac. 60 Hz  
T2—380 Vac. 50 Hz    \*\* T5—480 Vac. 60 Hz (standard)    T9—208 Vac. 50 Hz  
T3—415 Vac. 50 Hz    T6—575 Vac. 60 Hz    T10—230 Vac. 60 Hz  
T11—200Vac, 50 Hz

**EXAMPLE: DCR 16-625 T5 M9A**

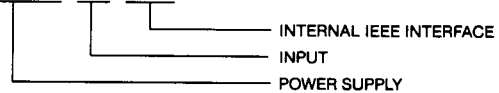

\*Standard on 5 kW units (no charge)    \*\*Standard on 10 kW units (no charge)

## Parallel Interface Controller (PIC)

A versatile new Parallel Interface Controller (PIC) provides central control and monitoring of up to four DCR-Ts operating in parallel. Centralized control eliminates the need to individually adjust each power supply or to add up the readings of each power supply output. Many operating configurations are possible, i.e., manual panel control, remote voltage or resistance programming, use with an IEEE-488 programmer, and others.

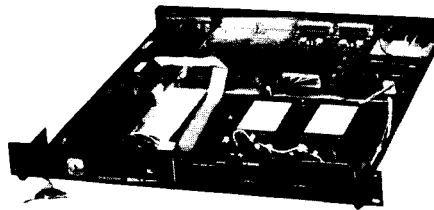

## PIC Models

- PIC 2:** Controls two DCR-Ts
- PIC 3:** Controls three DCR-Ts
- PIC 4:** Controls four DCR-Ts
- PIC 1-M9A (for 5 kW units only):** A PIC with an M9A IEEE-488 interface
- PIC 2-M9A:** Controls two DCR-Ts with an M9A IEEE-488 interface
- PIC 3-M9A:** Controls three DCR-Ts with an M9A IEEE-488 interface
- PIC 4-M9A:** Controls four DCR-Ts with an M9A IEEE-488 interface

Model <sup>4</sup>	Constant Current Mode			Temp Coeff., Current mA/°C (Typ.)	Current Drift (Typ.) % I <sub>o</sub> Max.	Programming Constants Current Mode		Power Factor (Typ.)		Efficiency <sup>3</sup> %	Case Size	Output Power kW
	Regulation mA <sup>1</sup>	Ripple (PARD) mA RMS	Resolution (Typ.)			Ohms/A	V/A	Lead	Lag			
DCR 4-800T*	400-900	3000	.025%	320	.05	12.5	0.0125	.9	.2	50	II	5
DCR 8-400T*	200-450	3000	.025%	200	.05	25.0	0.025	.9	.2	48	II	5
DCR 16-310T*	155-310	1500	.025%	200	.05	32.0	0.032	.9	.2	58	II	5
DCR 16-625T**	312-625	2000	.025%	250	.05	16.0	0.016	.9	.2	60	III	10
DCR 32-155T*	80-155	1000	.025%	100	.05	64.0	0.065	.9	.2	59	II	5
DCR 32-310T**	155-310	1500	.025%	124	.05	32.0	0.032	.9	.2	61	III	10
DCR 40-300T**	150-300	1500	.025%	124	.05	33.0	0.033	.9	.2	61	III	12
DCR 55-90T*	48-90	600	.025%	58	.05	111.0	0.111	.9	.2	61	II	5
DCR 55-180T**	90-180	900	.025%	72	.05	58.0	0.056	.9	.2	63	III	10
DCR 80-62T*	30-62	600	.025%	40	.05	161.0	0.161	.9	.2	62	II	5
DCR 80-125T**	62-125	900	.025%	50	.05	80.0	0.080	.9	.2	64	III	10
DCR 110-45T*	22-45	500	.025%	29	.05	222.0	0.222	.9	.2	63	II	5
DCR 110-90T**	45-90	800	.025%	36	.05	111.0	0.111	.9	.2	65	III	10
DCR 160-30T*	15-30	330	.025%	20	.05	333.0	0.333	.9	.2	64	II	5
DCR 160-62T**	31-62	480	.025%	25	.05	161.0	0.161	.9	.2	66	III	10
DCR 300-16T*	8-16	200	.025%	10	.05	625.0	0.625	.9	.2	65	II	5
DCR 300-33T**	16-33	240	.025%	13	.05	303.0	0.303	.9	.2	67	III	10
DCR 600-8T*	4-8	100	.025%	5	.05	1250.0	1.25	.9	.2	65	II	5
DCR 600-16T**	8-16	120	.025%	6	.05	625.0	0.625	.9	.2	67	III	10

# DCR-T Series Dimensional Drawings

## CASE II (8 3/4" High) Fan Cooled

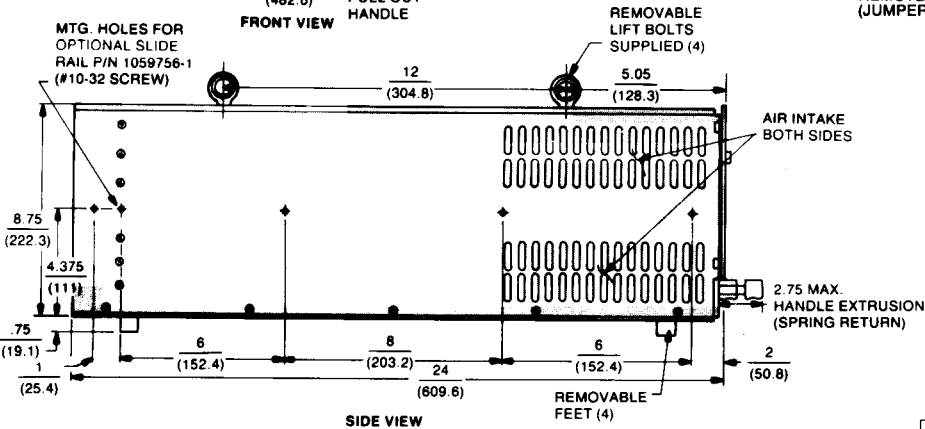
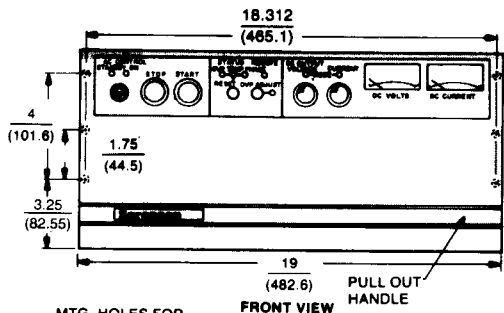

ALL MODELS EXCEPT  
DCR 4-800T

PARTIAL VIEW  
DCR 4-800T ONLY

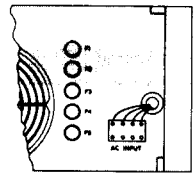
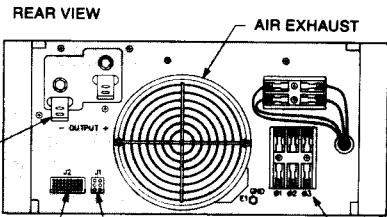

NOTE AC INPUT CONNECTIONS SHOWN WITH PROTECTIVE COVER REMOVED.

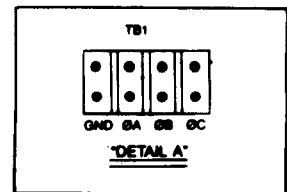

CASE SIZE	DIMENSIONS in. (mm)			WEIGHT lb (kg)
	Height	Width	Length	
II	8.75 (222.3)	19 (482.6)	24 (609.6)	185 (84)
III	12.25 (311.2)	19 (482.6)	24 (609.6)	310 (141)

## CASE III (12-1/4 in. High) Fan Cooled

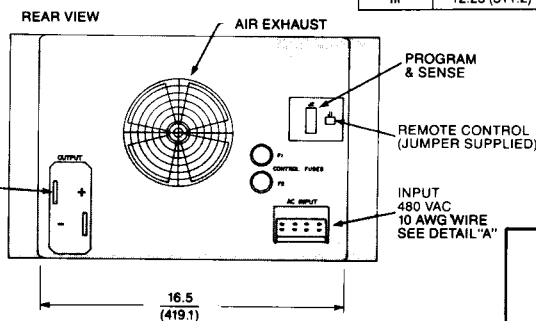
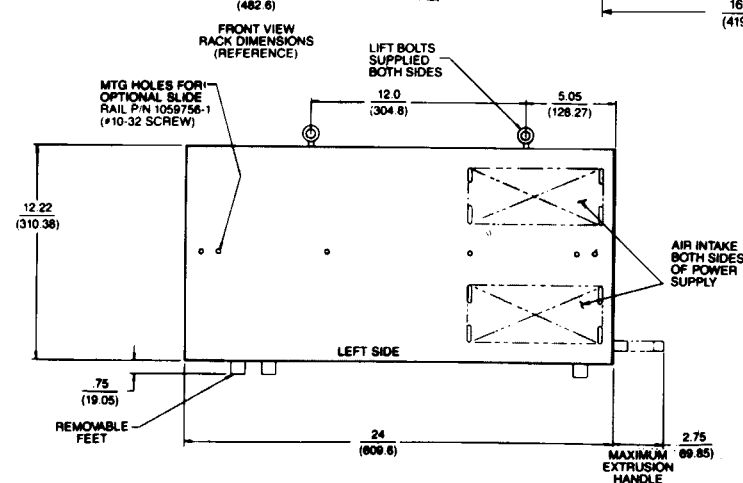
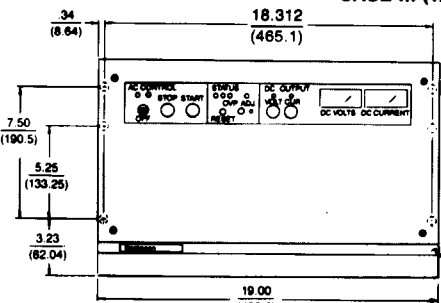

NOTE  
AC INPUT CONNECTIONS SHOWN WITH PROTECTIVE COVER REMOVED.

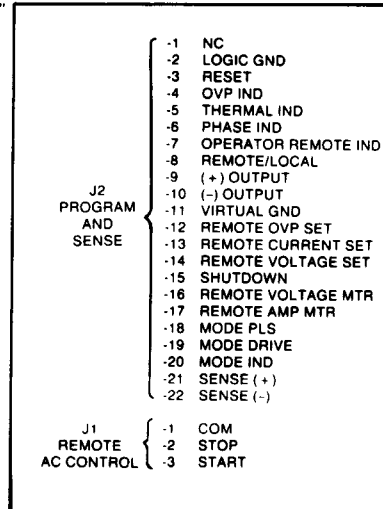

Note: All dimensions are in inches (mm)