

589338 (8/78)

PRINTED IN USA

SORENSEN
POWER SUPPLIES

instruction
manual
for

DCR-B SERIES
500-WATT
POWER SUPPLIES

Manual covers DCR-B Models;

10-40B	80-6B
20-25B	150-3B
40-13B	300-1.5B
60- 9B	600-.75B

SORENSEN COMPANY

A RAYTHEON COMPANY

676 ISLAND POND ROAD MANCHESTER, NEW HAMPSHIRE 03103

TABLE OF CONTENTS

<u>Section</u>	<u>Page</u>	<u>Section</u>	<u>Page</u>
Warranty			
Outline Drawing.....	v		
Unit Specifications.....	vi		
1. INTRODUCTION AND DESCRIPTION		4. PRINCIPLES OF OPERATION	
1.1 Introduction.....	1-1	4.1 Introduction.....	4-1
1.2 Description.....	1-1	4.2 Phase-Control Principle.....	4-1
1.3 Optional Modifications.....	1-3	4.3 Block-Diagram Analysis.....	4-3
1.4 Accessory OVP.....	1-3	4.4 Detailed Circuit Description.....	4-3
2. PREPARATION FOR USE		5. MAINTENANCE	
2.1 General.....	2-1	5.1 General.....	5-1
2.2 Initial Inspection.....	2-1	5.2 Periodic Servicing.....	5-1
2.3 Electrical Installation.....	2-1	5.3 Troubleshooting.....	5-1
2.4 Mechanical Installation.....	2-2	5.4 Calibration.....	5-1
2.5 Electrical Check.....	2-2	5.5 Performance Testing.....	5-3
3. OPERATING INSTRUCTIONS		5.6 Hi-Pot Test.....	5-6
3.1 General.....	3-1	6. DRAWINGS AND PARTS LISTS	
3.2 Voltage-Mode Operation.....	3-1	6.1 General.....	6-1
3.3 Current-Mode Operation.....	3-5	6.2 Parts List Column Headings Defined.....	6-1
3.4 Parallel Operation.....	3-7	7. OVERVOLTAGE (OVP) ACCESSORY (M5 OPTION)	
3.5 Series Operation.....	3-9	7.1 General.....	7-1
3.6 Unit-Shutdown Circuit.....	3-14	7.2 Installation.....	7-1
		7.3 OVP Adjustment.....	7-2

LIST OF ILLUSTRATIONS

<u>Figure No.</u>	<u>Title</u>	<u>Page</u>	<u>Figure No.</u>	<u>Title</u>	<u>Page</u>
	System Outline Drawing	v	4-1	Phase-Control Firing Angles..	4-1
3-1	DCR-B Controls and Indicators.....	3-2	4-2	DCR-B Functional Block Diagram.....	4-2
3-2	Remote Sensing Connections.....	3-3	4-3	Passing-Stage Principle.....	4-4
3-3	Voltage-Mode Programming Connections.....	3-4	5-1	Performance Test Setup.....	5-3
3-4	Current-Mode Programming Connections.....	3-6	6-1	DCR-B PCB Schematic Diagram..	6-3
3-5	Master-Slave Connections, Parallel Operation.....	3-8	6-2	PCB Component Layout Diagram..	6-5
3-6	Direct Parallel Connections.....	3-10	6-3	Component Layout, Typical Assembly.....	6-6
3-7	Master-Slave Connections, Series Operation.....	3-11	6-4	DCR-B Main Assembly Schematic Diagram.....	6-7
3-8	Direct Series Connections.....	3-14	7-1	OVP Assembly, Component Layout.....	7-2
			7-2	OVP PCB Schematic and Assembly Drawings.....	7-3

LIST OF TABLES

<u>Table No.</u>	<u>Title</u>	<u>Page</u>	<u>Table No.</u>	<u>Title</u>	<u>Page</u>
	Unit Specifications.....vi		5-2	Sensing Resistor Values, (Current-Mode Regulation Check).....5-5	
2-1	DCR-B Fine-Tuning Voltage Range...2-2		5-3	Unit Calibration-Specifications...5-5	
2-2	Wire Sizes, Current-Mode Check...2-3		6-1	Replaceable Parts List, DCR-B PCB Ass'y.....6-4	
3-1	Front Panel Controls and Indications.....3-2		6-2	Replaceable Parts List, DCR-B Main Ass'y.....6-9	
3-2	RA/RB Values - Two Identical DCR-B Units Series-Connected.....3-12		7-1	Replaceable Parts List, DCR-B OVP.....7-4	
3-3	Recommended Rectifiers, Series Operation.....3-12		7-2	OVP-Crowbar Rectifier (500W/1000W Series).....7-5	
5-1	DCR-B Troubleshooting.....5-2		7-3	OVP-Crowbar Rectifier (1800W/2700W Series).....7-5	

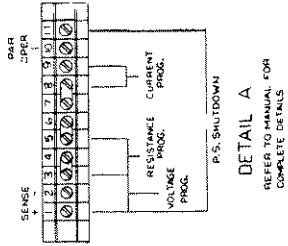

DETAIL A
REFER TO MANUAL FOR COMPLETE DETAILS

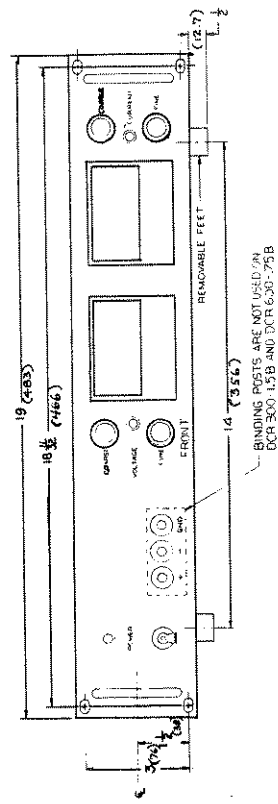
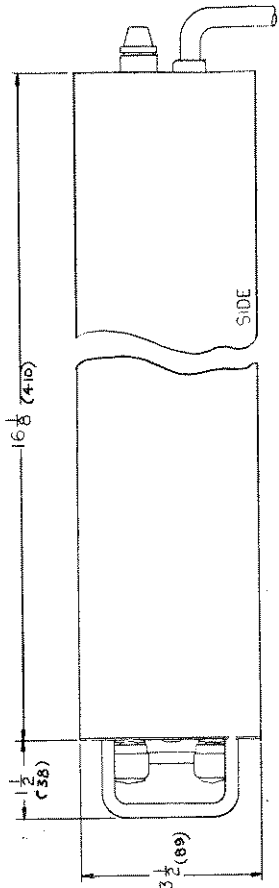
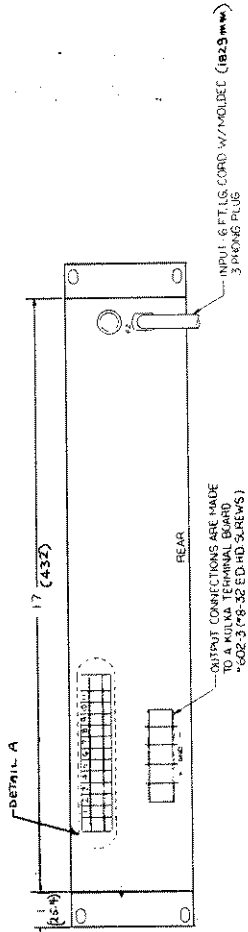

AVERAGE WT. PER UNIT IS 40LBS (18 kg)

Outline Drawing
DCR-B 500-Watt Series

**DCR-B SPECIFICATIONS
500-WATT SERIES**

DCR Model	OUTPUT POWER		Constant Voltage Ripple (PARD) (mV rms)	Constant Current Ripple (PARD) (mA rms)	TEMPCO (mV/°C) (mA/°C)	REMOTE PROGRAMMING (Ohms/V) (ohms/A)	SIGNAL (Volt In/ Volt Out)	Efficiency (% Typ.)	INPUT POWER		OUTPUT IMPEDANCE (Typical) 120Hz 1KHz 10KHz
	Voltage (Vdc)	Current (Adc) 40°C 71°C							Voltage Range (Vac) Note 3	Current Max (Aac) Note 4 (Typ.)	
10-40B	0-10	40	65	260	1.5 12	1200 10	1/1	61	103-127	8.7	.65 .025 .060
20-25B	0-20	25	65	82	3.0 7.5	600 16	1/2	71	103-127	9.4	.65 .030 .075
40-13B	0-40	13	90	30	6.0 3.9	300 30	1/4	71	103-127	9.8	.65 .050 .125
60-9B	0-60	9	125	19	9.0 2.7	200 46	1/6	75	103-127	9.7	.65 .075 .180
80-6B	0-80	6	150	12	12.0 1.8	150 68	1/8	77	103-127	8.3	.65 .125 .110 .300
150-3B	0-150	3	300	6	22.5 0.9	80 134	1/15	74	103-127	8.2	.65 .560 .530 .620
300-1.5B	0-300	1.5	700	4	45.0 0.45	40 270	1/30	74	103-127	8.9	.60 1.90 1.80 2.0
600-.75B	0-600	0.75	1200	2	90.0 0.225	20 530	1/60	74	103-127	8.9	.60 8.4 8.0 8.5

NOTES:

1. Overvoltage protector internal (optional), factory-installed.
2. Average weight, 40 lbs.
3. Optional Inputs: 208V, 220V, 230V (Options M1, M2, M3 respectively).
4. At 115V input.

COMMON SPECIFICATIONS

- Voltage Mode:**
Regulation: 0.03% with load change (NL-to-FL or FL-to-NL) and a full line-voltage change combined
Resolution: 0.05% of E_o max (typical)
Drift (% E_o max): 0.1% typical, for 8 hours after 30-minute warmup with constant line, load, and ambient temperature
- Current Mode:**
Regulation: 0.25% with 0-95% compliance-voltage change and ±10% line-voltage change combined.
Resolution: 0.05% of I_o max (typical)
Drift (% I_o max): 0.15% (typical)
- General:**
Series Operation: To 200 Vdc Maximum (150- and 300-volt models - 2 in Series)
Parallel Operation: By master-slave, four units maximum
Remote Sensing: 8 volts drop maximum per load lead, but not to exceed 10% E_o max
Operating Temperature Range: 0°C to 71°C
Storage Temperature: -40°C to + 85°C
Cooling: Convection
Isolation Voltage: 1000 Vdc input to output
Finish: Bonderize-Black semi-gloss with white lettering
Overload/Short-circuit Protection: Adjustable current limiting with automatic recovery
Overvoltage Protector: Internal, optional

1. INTRODUCTION AND DESCRIPTION

1.1 INTRODUCTION

This manual contains operation and maintenance data on the 500-watt units of the DCR-B series Sorensen Power Supplies. It is intended to familiarize the user with the functioning of the unit, to introduce the varied applications to which the unit may be adapted, and to furnish sufficient maintenance data to assure long operating life.

Seven major sections form the manual divisions. Section 1 contains a brief functional description of the DCR-B series power supplies. Initial inspection and checkout procedures are outlined in section 2. Operating instructions, including methods for adapting units to various applications, comprise section 3. Sections 4 and 5 provide the principles of operation and maintenance procedures respectively. System drawings and the replacement parts list are provided in section 6. Concluding the manual, section 7 describes the DCR-B OVP (overvoltage protector) accessory.

1.2 DESCRIPTION

1.2.1 General

Designed for either bench or rack use, the typical DCR-B power supply provides a highly regulated, precise d-c output, adjustable over a wide range. It operates from a nominal 115 Vac (208/220/230-Vac inputs are available as options) and exhibits a rapid response to transients, both load and line.*

Silicon-type semiconductors are used extensively in DCR-B circuitry, and contribute significantly to the units' wide ambient-temperature-range characteristic. Low-dissipation transistors and diodes are located on a single printed-circuit board while high-dissipation devices are heat-sinked to aluminum brackets.

All controls used during normal operation are mounted on the front panel. These include a power circuit breaker, FINE and COARSE VOLTAGE adjust potentiometers, and FINE and COARSE CURRENT adjust potentiometers. The system output is taken across a terminal pair at the rear terminal strip or from the binding posts at the front of the supply.

*A variety of Sorensen power supply application notes are available through your Sorensen Service Representative.

1.2.2 Automatic Crossover.

There are two basic operating modes; voltage and current. In the voltage mode, the voltage is held constant while the current varies with the load, while in the current mode, the voltage varies, and current is held constant. The automatic crossover feature enables the unit to switch operating modes as a function of load requirements. If, for example, load current attempts to increase above a preset current limit, the unit will switch operation automatically from the voltage to the current mode. In this mode, the current will be regulated at the value preset on the front panel. If load requirements are lowered, return to the voltage-regulating mode will occur automatically. A red lamp on the front panel glows to indicate the current-mode operation.

1.2.3 Remote Sensing.

Terminals located on the rear-mounted terminal board offer the means of extending a unit's regulating point from the output terminals to the load. This effectively compensates for variations in the load-lead IR drop. Section 3 outlines the connections for remote sensing.

1.2.4 Series Operation.

For applications requiring output voltages higher than a single unit can provide, DCR-B power supplies may be connected in series (See section 3). Regulation in series operation is the sum of the regulations for all units.

1.2.5 Parallel Operation.

Parallel operation may be used to service those applications requiring an output current higher than a single supply can provide. Using a "master-slave" approach, a maximum of four units may be connected in parallel. An alternate method is direct paralleling. With this approach, there is no limit to the number of units which can be paralleled. The regulation will deteriorate, and could be the sum of the regulations for the individual settings plus the output-voltage differences between units at no load.

1.2.6 Remote Programming.

Output voltage or current of DCR-B power supplies may be programmed in either the voltage or current mode by resistance or voltage signal. This feature permits the user to change the output voltage or current to preset values from remote locations.

1.2.7 Unit Shutdown Circuit.

In the DCR-B line, application of the (+) sense to terminal 11 of terminal board J1 on the rear panel instantly shuts down the supply. This function can provide unit protection by connecting a temperature-or voltage sensitive switch (or transistor) in this line to shut the system down under specified conditions. A typical application is in the master-slave connection of two DCR-B supplies. If the shutdown function is applied to the master unit, system output goes to zero; applied to the slave unit, only that unit is affected, and system output is reduced accordingly.

1.2.8 Protection Features

Protection against the effects of overloads and internal short circuits is provided. Overload protection is inherent in automatic crossover. The main power circuit components are protected by the unit circuit breaker.

1.3 OPTIONAL MODIFICATIONS

The standard DCR-B unit is designed for operation from a nominal 115-Vac input; however, units may be purchased factory-modified to accept inputs of 208, 220 or 230 Vac (modifications M1, M2 or M3 respectively).

1.4 ACCESSORY OVP (M5 Option)

An overvoltage-protector circuit (OVP) is available as an accessory to Sorensen's DCR-B power supplies. The circuit may be factory-installed or purchased as a kit and field-installed. Complete installation and operation procedures are provided in section 7 of this manual.

2. PREPARATION FOR USE

2.1 GENERAL

After unpacking, initial inspections and preliminary electrical check procedures should be performed to assure that the unit is in good working order. If it is determined that the unit is damaged, the carrier should be notified immediately. Repair problems should be directed to the nearest Sorensen representative, or to the Service Department, Sorensen Company, Manchester, New Hampshire 03103.

2.2 INITIAL INSPECTION

Proceed as follows to inspect for damage incurred during shipment.

1. Inspect panel and chassis for scratches, dents, and chips.
2. Turn front-panel voltage and current controls from stop to stop. Rotation should be smooth through a 300-degree angle.
3. Check meter faces for cracked or broken windows. Check each meter pointer for zero indication. If necessary, use adjust screw to bring indicator to zero.
4. Look for cracked or broken lenses on indicating lights.
5. Alternate power switch between ON and OFF a few times. Action should be both positive and audible. Terminate check with switch in OFF position.
6. Inspect power input cord for obvious signs of damage. Tug lightly on cord near chassis to assure that relief grommet grips cord.
7. Remove rear cover, and check terminal board. Make sure that links are firmly in place across terminals 3-4, 5-6, and 7-8.
8. Remove top-cover retaining screws. Inspect components and printed circuit board for damage.

2.3 ELECTRICAL INSTALLATION

Standard 500-watt units are shipped ready for use with a nominal 115-Vac input, but may be factory-modified to operate with nominal inputs of 208, 220, or 230 volts.

2.3.1 Input Power Cord

The input power cord terminates externally in a three-prong polarized plug. The unit chassis is wired to the plug through the line cord, and therefore, the insertion of the plug into a compatible receptacle, hooked up to a grounded input, will automatically ground the unit. If a grounded input is not available, use an adapter, making sure that the adapter's external lead is well grounded.

2.4 MECHANICAL INSTALLATION

As received, the unit is ready for bench use. To adapt for rack mounting, simply invert the unit, remove feet and reinstall the feet-retaining screws.

2.5 ELECTRICAL CHECK

2.5.1 Voltage Mode

To check voltage-mode operation, proceed as follows:

1. With POWER switch OFF, connect appropriate input power per paragraph 2.3.
2. Turn COARSE and FINE VOLTAGE controls fully counterclockwise, and COARSE CURRENT control fully clockwise.
3. Set unit power to ON with zero load current.
4. Turn COARSE VOLTAGE control slowly clockwise while observing the unit voltmeter. The pointer should swing upscale, and the voltage indicator light should be ON.
5. With the pointer at half scale, rotate the FINE VOLTAGE control from stop to stop. The voltage should vary according to Table 2-1.

Table 2-1 DCR-B Fine-Tuning Voltage Range

Model Voltage	Fine-Tuning Range
10	0.041V
20	0.083V
40	0.166V
60	0.250V
80	0.333V
150	0.625V
300	1.25V
600	2.5V

2.5.2 Current Mode

1. With unit power OFF, turn COARSE and FINE CURRENT controls fully counterclockwise, and set COARSE VOLTAGE control to its approximate mid-position.
2. Connect approximately four feet of copper wire across the output terminals (wire sizes are listed in Table 2-2).
3. Set unit power to ON. CURRENT mode indicator will illuminate.
4. Rotate COARSE CURRENT control slowly clockwise until a current indication appears. Continue clockwise rotation, and the meter indication will increase accordingly.
5. Set unit power to OFF, and remove shorting wire.

Table 2-2 Wire Sizes, Current-Mode Check

DCR-B Model	Wire Size
10-40B	No. 10
20-25B	No. 12
40-13B	No. 14
60-9B	No. 18
80-6B	No. 20
150-3B	No. 24
300-1.5B	No. 28
600-.75B	No. 28

3. OPERATING INSTRUCTIONS

3.1 GENERAL

This section provides basic operating instructions, and details the methods by which DCR-B power supplies may be adapted to their more common applications including remote sensing, remote programming, and series and parallel operation. Table 3-1 identifies the operating controls shown in Figure 3-1, and describes their functions.

WARNING

1. *Full system voltage appears across the unit output terminals both front and rear. Follow operating procedures exactly, and do not make terminal-board or load-terminal alterations with unit power ON.*
2. *High-voltage output (which may damage the load or injure personnel) and loss of current limiting (which may result in a damaged unit) can result from loosening or removing links on the rear-mounted terminal board. Do not remove or loosen any links unless specifically instructed to do so in subsequent procedures.*

3.2 VOLTAGE-MODE OPERATION

3.2.1 Local Sensing

DCR-B series units are shipped ready for use in the local-sensing configuration, that is, with unit regulation occurring at the output terminals. This may be undesirable if variations in the load-lead voltage drops are expected to be large in comparison with the unit's specified regulation. To compensate for prohibitive drops, remote sensing may be used (paragraph 3.2.2).

To operate unit in the voltage-mode, local-sensing configuration proceed as follows:

1. Rotate the FINE and COARSE VOLTAGE controls fully counterclockwise, and the CURRENT controls fully clockwise.
2. With unit power OFF, connect appropriate input voltage.
3. Set unit power to ON. Power light will illuminate.

Table 3-1 Front Panel Controls and Indicators

CONTROL/INDICATOR	FUNCTION
POWER indicator (DS1)	A white light connected across the primary of input transformer T2. When glowing, indicates that the unit power switch is in the ON position.
POWER switch (S1)	A 250-volt, 10-ampere switch used to connect or disconnect input line voltage.
TP1/TP2/TP3	Output voltage jacks: (+)/(-)/Grd
COARSE VOLTAGE adjust (R8)	A 12K-ohm potentiometer across which the reference voltage for voltage-mode operation is developed. Used to adjust the output voltage.*
FINE VOLTAGE adjust and FINE CURRENT adjust (R9/R12)	80-ohm potentiometers in series with the COARSE VOLTAGE and CURRENT potentiometers, used to make slight variations in the output voltage or current.
VOLTAGE mode indicator (DS2)	A red light which illuminates when the unit is operating in the voltage-regulating mode.
Panel voltmeter (M1)	A meter connected internally across the SENSE terminals, to indicate unit output voltage.
Panel current (M2) meter	A meter connected in series with the negative output, to indicate unit output current.
CURRENT mode indicator (DS3)	A red light which illuminates when the unit is operating in the current-regulating mode.
COARSE CURRENT adjust (R11)	A 650-ohm potentiometer used in the first stage of the current-mode amplifier to vary the reference, and subsequently the output current.

*Local sensing mode only. With remote sensing, indicates voltage across load.

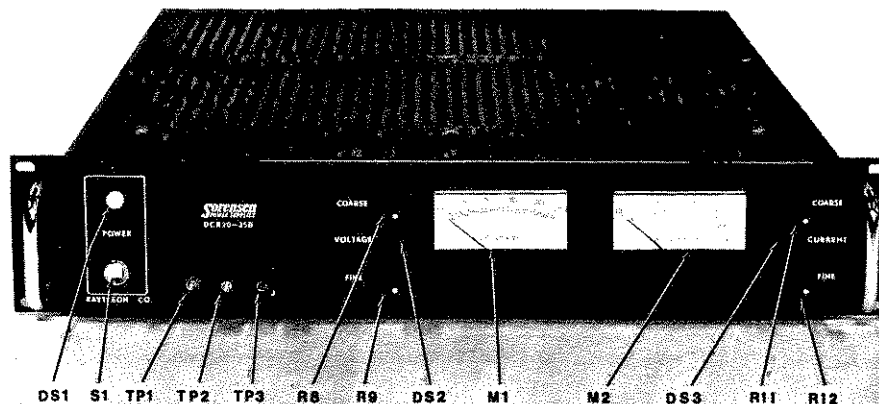

Figure 3-1
DCR-B Controls and Indicators
(Ref. Table 3-1)

4. Rotate COARSE VOLTAGE control until the unit voltmeter indicates the desired output voltage. Use FINE VOLTAGE control for small sensitive adjustments.

5. Set unit power to OFF.

6. Remove rear cover and connect load lines to terminals (+) and (-). Remount cover.

7. Set unit power to ON, and turn CURRENT control to the desired current-limiting value. POWER light will illuminate, and the unit is in voltage-mode operation.

NOTE

With unit in the voltage mode, an increase in load-current requirements above the value set in step 7 preceding will cause an automatic crossover to the current-mode (current-limiting). The current-mode indicator will illuminate when this occurs.

3.2.2 Remote Sensing (Figure 3-2)

In the remote-sensing condition, voltage regulation is at the load rather than at the unit output terminals, thus compensating for voltage-drop variations in the load lines.

NOTE

A voltage drop not to exceed 10% of full unit output is the maximum for which remote sensing will compensate. Voltage across load is equal to voltage output of unit minus line drops.

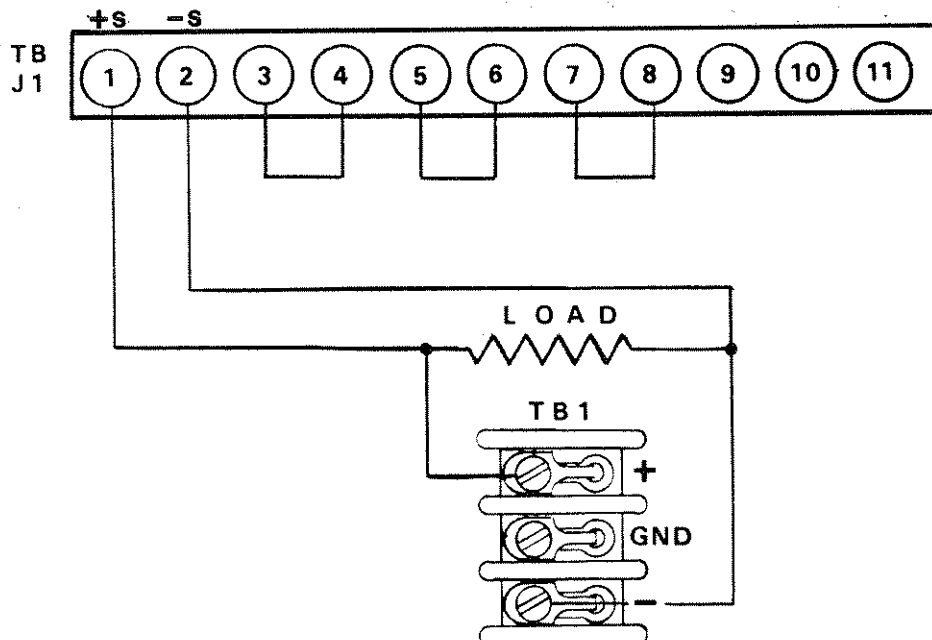

Figure 3-2
Remote Sensing Connections

To adapt unit for remote-sensing operation, proceed as follows:

1. With no load on unit, apply input power and set output voltage to the desired value; then set power to OFF.
2. Remove rear cover and disconnect red and black wires going from (+) and (-) output terminals to (+S) and (-S) sensing terminals.
3. Run output lead from the load through the holes in the rear cover to the (+) and (-) output terminals.
4. Connect sensing leads from (+S) and (-S) terminals to the load. Observe Polarity. To reduce stray pickup, use shielded pair (shield grounded at the supply) or a twisted pair of wires for sensing leads.
5. Remount the rear access cover and set unit power to ON.

3.2.3 Resistance Programming (Figure 3-3)

The output voltage of any model in the DCR-B series may be controlled from remote locations by connecting a resistance (fixed or variable) into the voltage-mode amplifier reference circuit. Terminals on the rear terminal board are provided for this purpose.

The ohms/volt sensitivity for each unit is listed in the specifications. The selected programming resistor should have a low temperature coefficient (± 30 ppm), and will dissipate approximately 10 milliwatts. Programming current is approximately 1.0 milliamperes. If step changes in the programmed output are to be made by abrupt changes in programming resistance, make-before-break switching should be used.

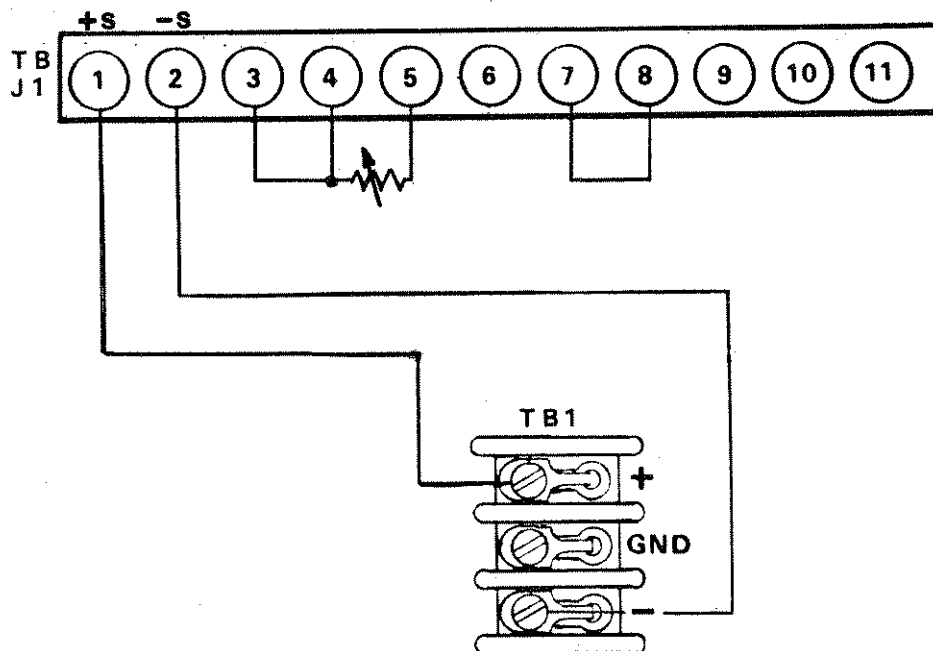

Figure 3-3
Voltage-Mode Programming Connections

To adapt unit to resistance-programming operation, proceed as follows:

1. Set unit power to OFF.
2. Remove link between terminals 5 and 6, and connect programming resistor between terminals 4 and 5 (Figure 3-3). Use shielded or twisted wire for interconnecting leads.
3. Rotate COARSE and FINE VOLTAGE controls fully counterclockwise. Set POWER switch to ON.
4. Rotate CURRENT control to desired limiting value. Remove input power, and connect load to output terminals.
5. Set unit power to ON. Unit supplies programmed voltage to load.

CAUTION

If programming operation is to be discontinued, set unit power to OFF, remove programming resistor, and reconnect link between terminals 5 and 6.

3.2.4 Signal Programming

A fixed or variable voltage signal may be impressed on the voltage-mode amplifier circuit to provide a fixed or variable voltage output. The selected signal source output should be "Floating", unless the (+) output of the supply is grounded. Proceed as follows:

1. Remove link from between terminals 3 and 4.
2. Connect the signal source between terminals 3 and 1. Observe Polarity (positive end to terminal 3). Signal level should not exceed 12 volts.

3.3 CURRENT-MODE OPERATION

In current-mode operation, the current output is regulated at the value determined by the setting of the current controls. The output voltage varies as a function of load. To operate unit in the current mode proceed as follows:

1. Rotate FINE and COARSE VOLTAGE controls fully counterclockwise, and adjust COARSE CURRENT control approximately three quarters clockwise.
2. Set unit power to ON.
3. Rotate COARSE VOLTAGE control clockwise until unit voltmeter indicates the desired voltage limit.
4. Set unit power to OFF.
5. Connect load to output terminals. Observe Polarity.
6. Set unit power to ON, and turn current controls to desired current-regulation setting. POWER and CURRENT MODE lights will illuminate, and unit will deliver constant, regulated current to load.

NOTE

Any output instability (such as oscillations due to inductive loading) can be eliminated by adjusting potentiometer R45 on the unit PCB (Figure 6-2, page 6-5)

NOTE

If voltage increases above the limit set in step 3 preceding, unit automatically crosses over to voltage-mode operation.

3.3.1 Resistance Programming (Figure 3-4)

DCR-B supplies may be programmed externally to provide a predetermined level of output current, fixed or variable. This is done by inserting the fixed or variable resistance into the current-mode amplifier-reference circuit. The programming resistor selected should have a low temperature coefficient (± 30 ppm) and will dissipate approximately 0.5 milliwatt. Programming current is approximately 1.0 milliampere.

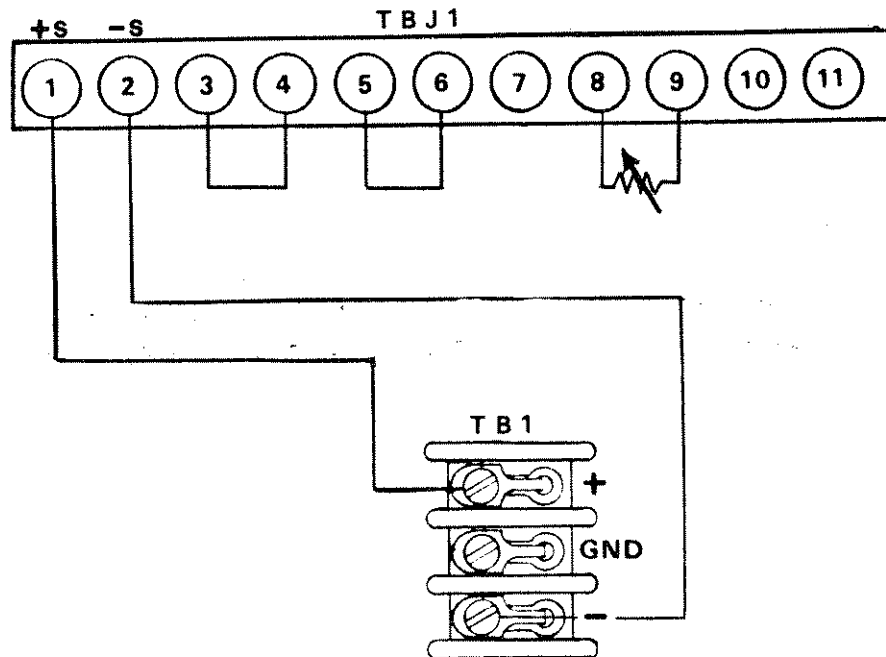

Figure 3-4
Current-Mode Programming Connections

To adapt unit to the current-mode, resistance-programming configuration, proceed as follows:

1. Setup current mode limit settings as outlined in Section 5, Page 5-2, Paragraph 5.4.2 of this manual.
2. With unit power OFF, remove the link between terminals 7 and 8, and rotate voltage controls to mid position.
3. Insert programming resistor between terminals 8 and 9.

4. Adjust COARSE VOLTAGE control until unit voltmeter indicates desired voltage-limit value.
5. Set unit power to OFF, and connect load leads to output terminals. Observe Polarity.
6. Set unit power to On. POWER-and CURRENT-mode indicators will illuminate.



If resistance programming is to be discontinued, set unit power to OFF, remove programming device, and reconnect link between terminals 7 and 8.

3.3.2 Signal Programming

The procedure for adapting a DCR-B unit to current-mode signal programming is identical to that for current-mode resistance programming (paragraph 3.3.1), except that the signal source, rather than the programming resistor, is connected across terminals 8 and 9. A floating (ungrounded) signal source capable of delivering approximately 1.0 mA should be selected, and twisted wires should be used for the interconnecting leads. For a full-range variation in unit output current, signal must have 0-to 0.6-volt range (0-0.4 volts if negative offset potentiometer is connected per step 2 of paragraph 3.3.1).

3.4 PARALLEL OPERATION

DCR-B single-phase units may be paralleled using either of two methods. One method uses a "master-slave" approach, and the other involves direct paralleling. Each method has its advantages: in "master-slave" operation, output voltage regulation specifications are maintained, but only four units may be paralleled; with the direct method, there is no limit to the number of units which may be paralleled, and no current derating is required, but output-voltage regulation does deteriorate.



Contact the factory if unit(s) to be paralleled contain the overvoltage protection accessory (per section 7).

3.4.1 Master-Slave Paralleling (Figure 3-5)

Instructions for connecting two units in parallel follows:

NOTE

Up to three "slave" units may be added by extending this procedure.

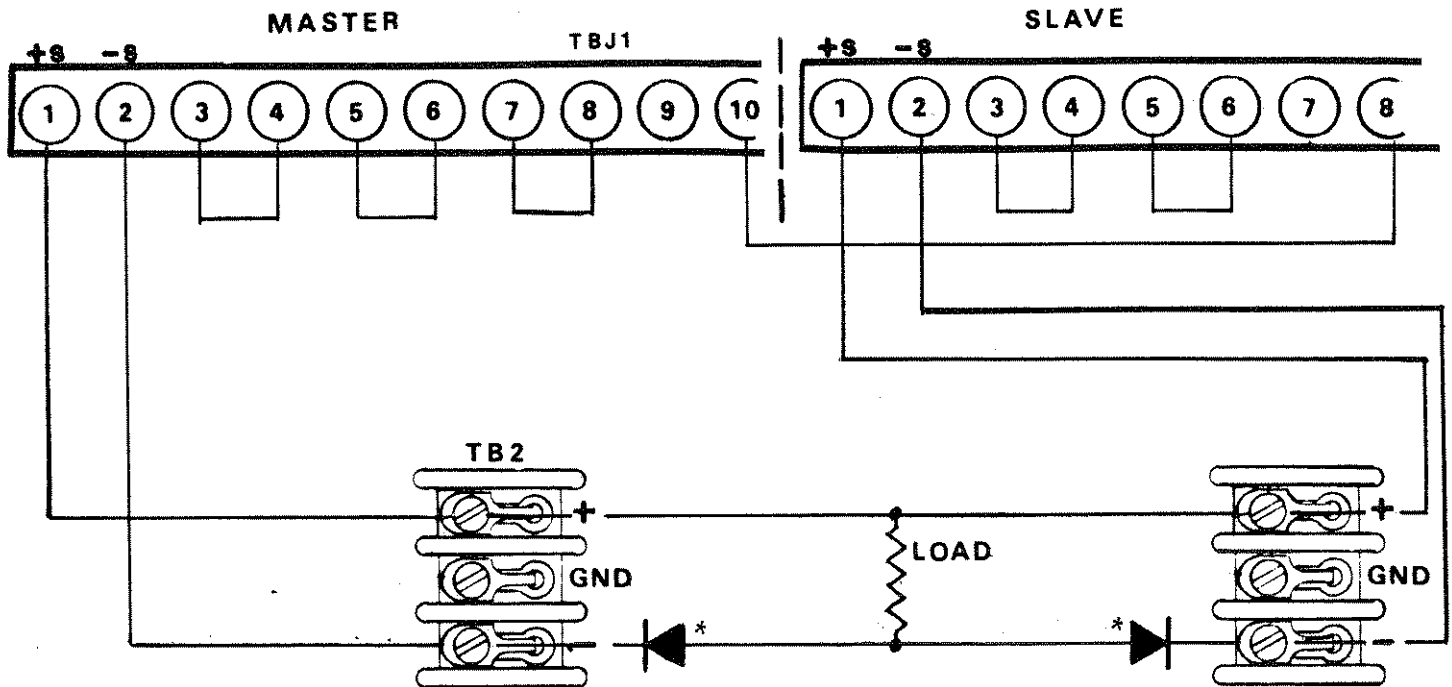

**Required only when OVP (see section 7) is used on either unit. Forward diode types listed in Table 3-3 for series connection will be adequate. Heatsinking is also necessary.*

Figure 3-5
Master-Slave
Connections, Parallel Operation

1. With no load applied, set master unit power to ON, and adjust voltage to desired system output (plus total load-lead drop unless in the remote-sensing mode) Set unit power to OFF.
2. Connect load leads from both units to the load. If possible, use load leads of approximately equal length. Observe Polarity.
3. Disconnect link between terminals 7 and 8 on slave unit. Set slave voltage controls fully clockwise. Connect wire between terminal 8 of slave unit and terminal 10 of master unit.
4. Set master-unit power to ON, and then apply the slave-unit power.

3.4.2 Direct Paralleling (Figure 3-6)

The following steps outline the procedure for connecting two units in parallel (the same procedure may be extended to parallel as many units as desired):

1. At no load, adjust individual unit voltages to desired system output. Attempt to match individual unit outputs with FINE VOLTAGE controls.
2. Set power to each unit to OFF, and run load leads from units to load. Observe Polarity.
3. If remote sensing is to be used, connect sensing leads from units to load, also observing polarity. Use twisted wire or shielded pair for leads.
4. Set each unit power switch to ON. POWER indicators will illuminate.

The unit supplying the highest voltage will supply the load, as it is impossible to identically match the output voltages. If the load requirements exceed the setting on the CURRENT control, this unit will automatically cross over to current-mode operation, and its output voltage will drop. The second unit will then assume that portion of the load rejected by the first. Any further increases in load will be supplied by the second unit up to its current-limit setting. Regulation, therefore, will be the sum of the regulations of the two units (or whatever number of units are being paralleled), plus the difference in the voltage settings.

3.5 SERIES OPERATION

3.5.1 Master-Slave Connection (Figure 3-7)

The voltage range of a DCR-B power-supply system can be increased by series-connecting units up to a total rated output of 200Vdc (150- and 300-volt models, two in series) in a "master-slave" configuration. Two 40-volt supplies thus connected provide 0- to 80-volt range capability with voltage programming of only one unit necessary. External components required are two wire-wound resistors (R_A and R_B in the figure), and a 15- μ F bypass capacitor to eliminate noise feedthrough, for each unit except the final unit in the series, and a shunt power rectifier across the output terminals of each unit.

Assuming two supplies with the same output ratings are to be used, (consult factory for connecting dissimilar units), connect as shown in Figure 3-7. R_A and R_B are low-TC, wire-wound resistors of 5 watts rating or greater. Resistance values for two identical units in series have been calculated for all voltage ranges in the DCR-B series, and are summarized in Table 3-2. Recommended types of power rectifier are listed in Table 3-3 for each application.

NOTE

For more than two units (with identical output ratings) connected in series, R_B remains 10K, and R_A is calculated using the formula: $R_A = 10^3 (V_o - 10)/X$

where V_o is the voltage of the master supply, and X is the number of units in the system.

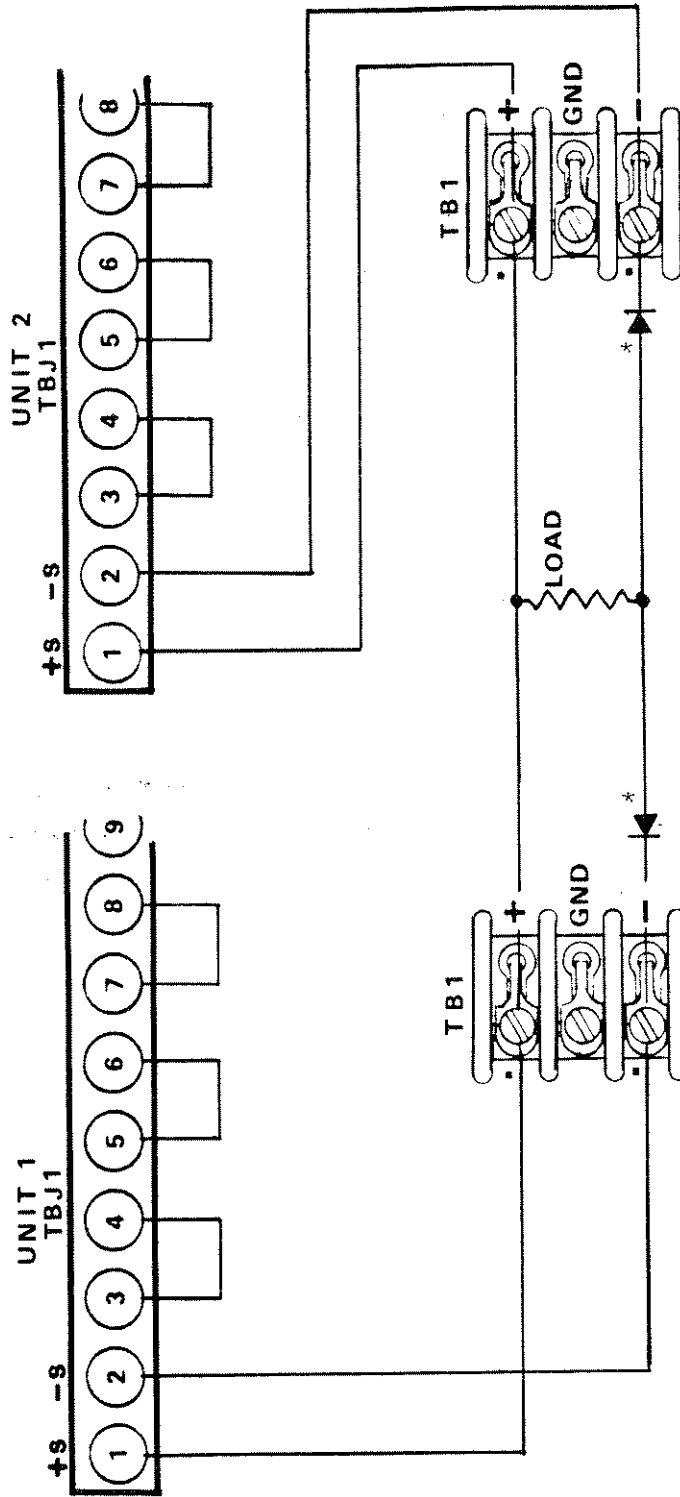

▪ For remote sensing, connect both unit "+"s and "-"s terminals directly to the load instead of output terminal board. OBSERVE POLARITY.

*Required only when OVP (see section 7) is used on either unit. Forward diode types listed in Table 3-3 for series connection will be adequate. Heatsinking is also necessary.

Figure 3-6
Direct Parallel Connections
(Shown in local-sensing mode)

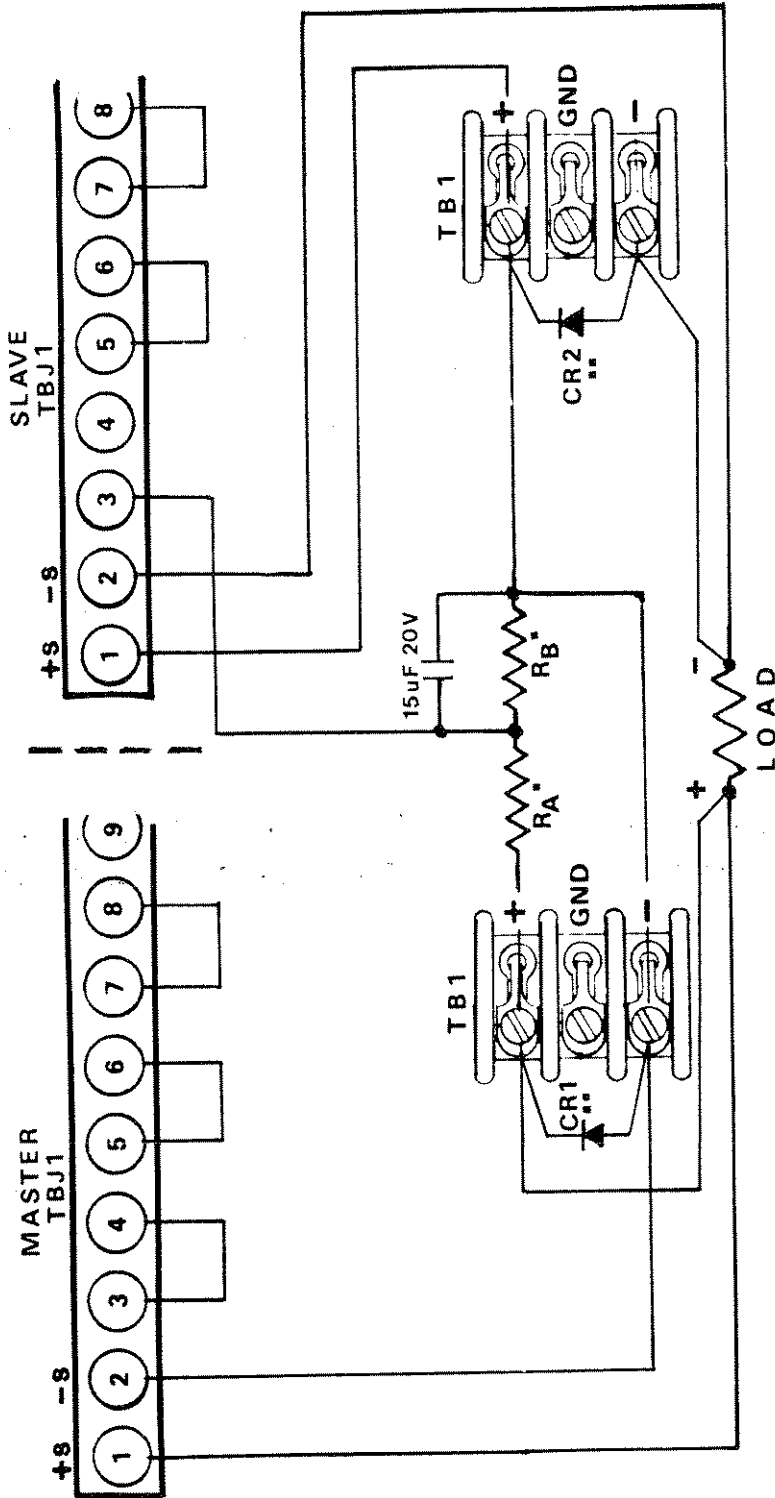

▪ See Table 3-2
 ▪▪ See Table 3-3

Figure 3-7
 Master-Slave Connections
 Series Operation
 (Shown in remote-sensing mode)

Table 3-2
 RA/RB Values--Two Identical
 DCR-B Units Series-Connected

(V) Rated	RA	RB
10 ^x	Open	Open
20	5K	10K
40	15K	10K
60	25K	10K
80	35K	10K
150	70K	10K
300	145K	10K
600	295K	10K

^xFor 10-volt units, terminal 3 of the slave unit is connected directly to the (+) sense terminal of the master unit.

Table 3-3
 Recommended Rectifiers, Series Operation

DCR Model	Type	Sorensen Part No.	Heatsink ^a Dim. Inches (mm)
10-40B	1N4587 1N4587R*	587571-1 587571-3	4 x 4 x 1/8 (102) x (102) x (3.2)
20-25B	1N1183 1N1183R*	587382-1 587382-6	3-1/2 x 3-1/2 x 1/8 (89) x (89) x (3.2)
40-13B	MR1121 MR1121R*	26-1046-2 26-1046-12	2-3/4 x 2-3/4 x 1/8 (70) x (70) x (3.2)
60-9B	MR1121 MR1121R*	26-1046-2 26-1046-12	3 x 3 x 1/32 (76) x (76) x (.8)
80-6B	MR1122 MR1122R*	26-1046-4 26-1046-12	1-3/4 x 1-3/4 x 1/32 (44) x (44) x (.8)
150-3B	3S12 (2)	587566-2	Non-Req'd.
300-1.5B	3S14 (2)	587566-3	Non-Req'd.
600-.75B	3S18 (2)	587566-5	Non-Req'd.

*Reverse-polarity rectifiers
^aFlat aluminum plate

With unit power switches OFF, connect each unit to appropriate input power source (115/208/220/230Vac). All units in the system may be connected through a common ac line OFF/ON switch. Proceed as follows:

1. Set the COARSE and FINE CURRENT controls of each unit fully clockwise.
2. Set the slave-unit POWER switch to ON.
3. Set the master-unit COARSE and FINE VOLTAGE controls fully counter-clockwise, and set its POWER switch to ON.
4. Adjust master-unit controls for desired system output level, which, in the case of two identical units, will be twice that indicated on its panel meter.

NOTES

(a) System output for series-connected units of different power ratings will be the sum of the individual unit voltages, at a maximum current level equal to that of the lowest unit current rating.

(b) In multiple-unit operation, a greater time lag must be anticipated to reach full system output at each power turn-on.

3.5.2 Direct Series Connections (Figure 3-8)

DCR-B supplies may be directly series-connected up to a total output of 200Vdc. System regulation is the sum of the regulations of all units.

The procedure is outlined for connecting two units in series. Additional units may be connected by repeating the procedure for each.

NOTE

Series-connected units may be adapted to resistance or signal programming.

1. With no load connected, set each unit to its desired output voltage level, and appropriate current-limiting value.
2. Set power to each unit to OFF.
3. Interconnect units as shown in Figure 3-8.



Rectifiers (and heatsinks where required) must be connected across the output terminals of each unit as shown in the figure. This will prevent damage to the output capacitors. Specific rectifier types are listed in Table 3-3.

4. Set unit power switches to ON. Units operate with independently adjustable outputs, and the power to each may be set ON or OFF separately.

3.6 UNIT SHUTDOWN CIRCUIT

In the DCR-B line, application of the (+) sense (terminal 1) to terminal 11 of terminal board J1 instantly shuts down the supply. This function can provide unit protection by connecting a temperature-or voltage-sensitive switch (or transistor) in this line to shut the system down under specified conditions. An example is in the master-slave connection of two DCR-B power supplies. If the shutdown function is adapted to the master unit, the system output goes to zero; applied to the slave unit, only that unit is affected and the system output is reduced accordingly.

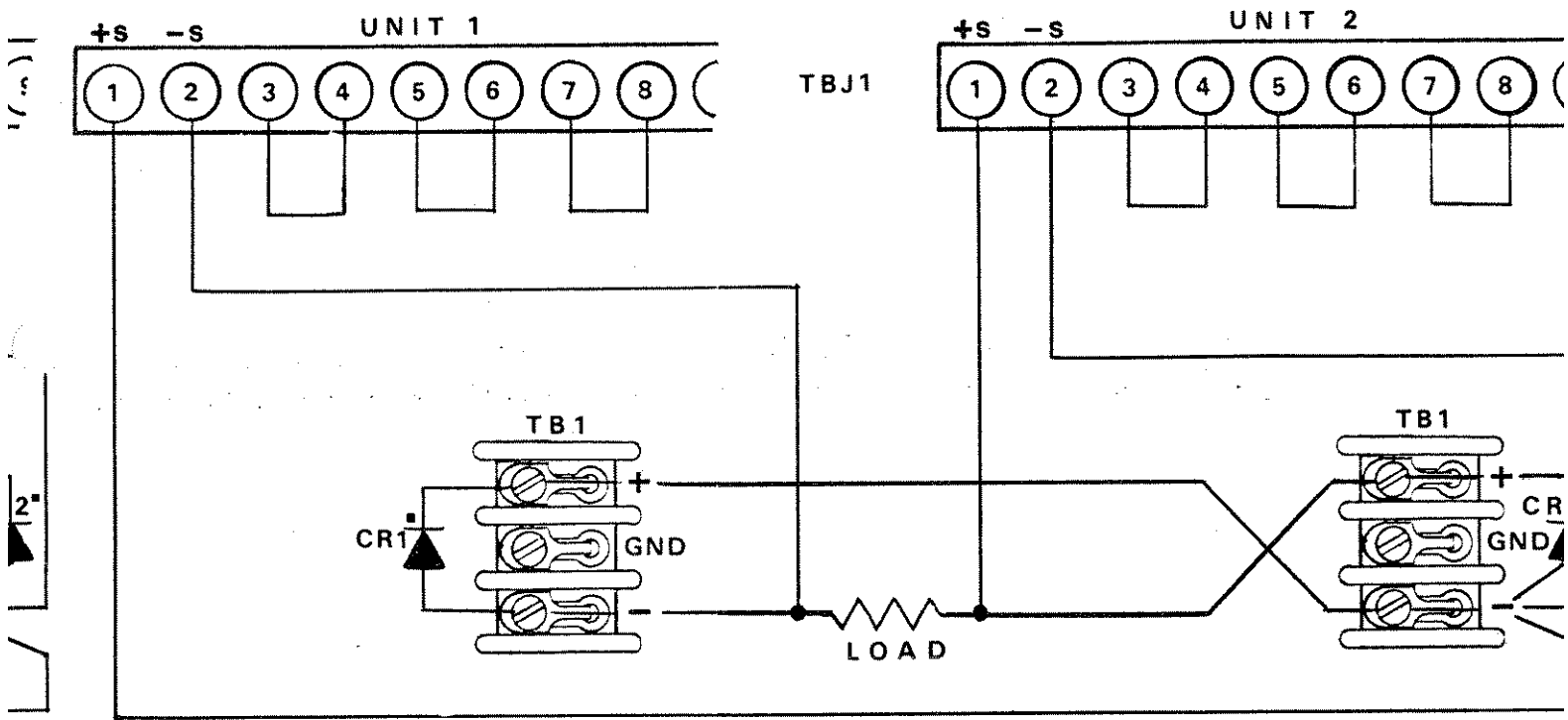

See Table 3-3

Figure 3-8
Direct Series Connections
(Remote Sensing)

4. PRINCIPLES OF OPERATION

4.1 INTRODUCTION

This section provides a basic discussion of unit operating principles which may be used in conjunction with the troubleshooting chart provided in Section 5, to enable the logical and rapid isolation of unit faults. A brief description of the phase-control principle is given first, followed by a block-diagram analysis of system functions. The function of each section is then described in detail.

4.2 PHASE-CONTROL PRINCIPLE

The sinusoidal wave in Figure 4-1 represents normal a-c line voltage. If, by some means, conduction of this voltage is delayed, the average voltage output will be reduced. Control of the delay then results in control of the average voltage. This is phase control, and the device causing the delay is a Triac, or silicon-controlled rectifier (SCR). The delay is expressed in degrees and is known as the firing angle. Figure 4-1 shows firing angles of 60° (shaded area plus cross-hatched area) and 120° (cross-hatched area only).

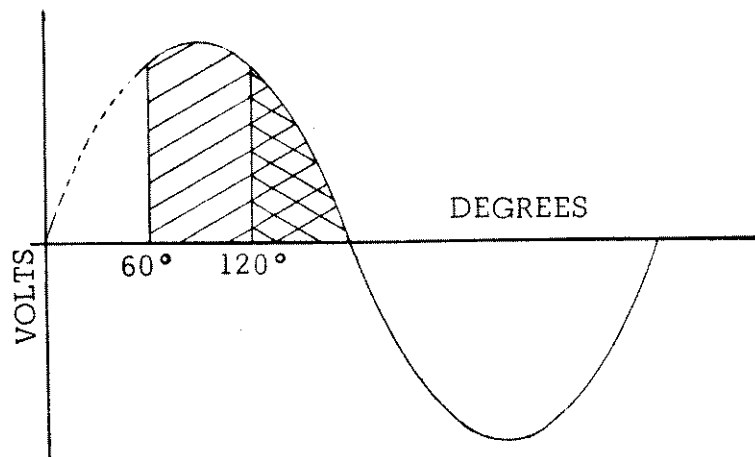

Figure 4-1 Phase-Control Firing Angles

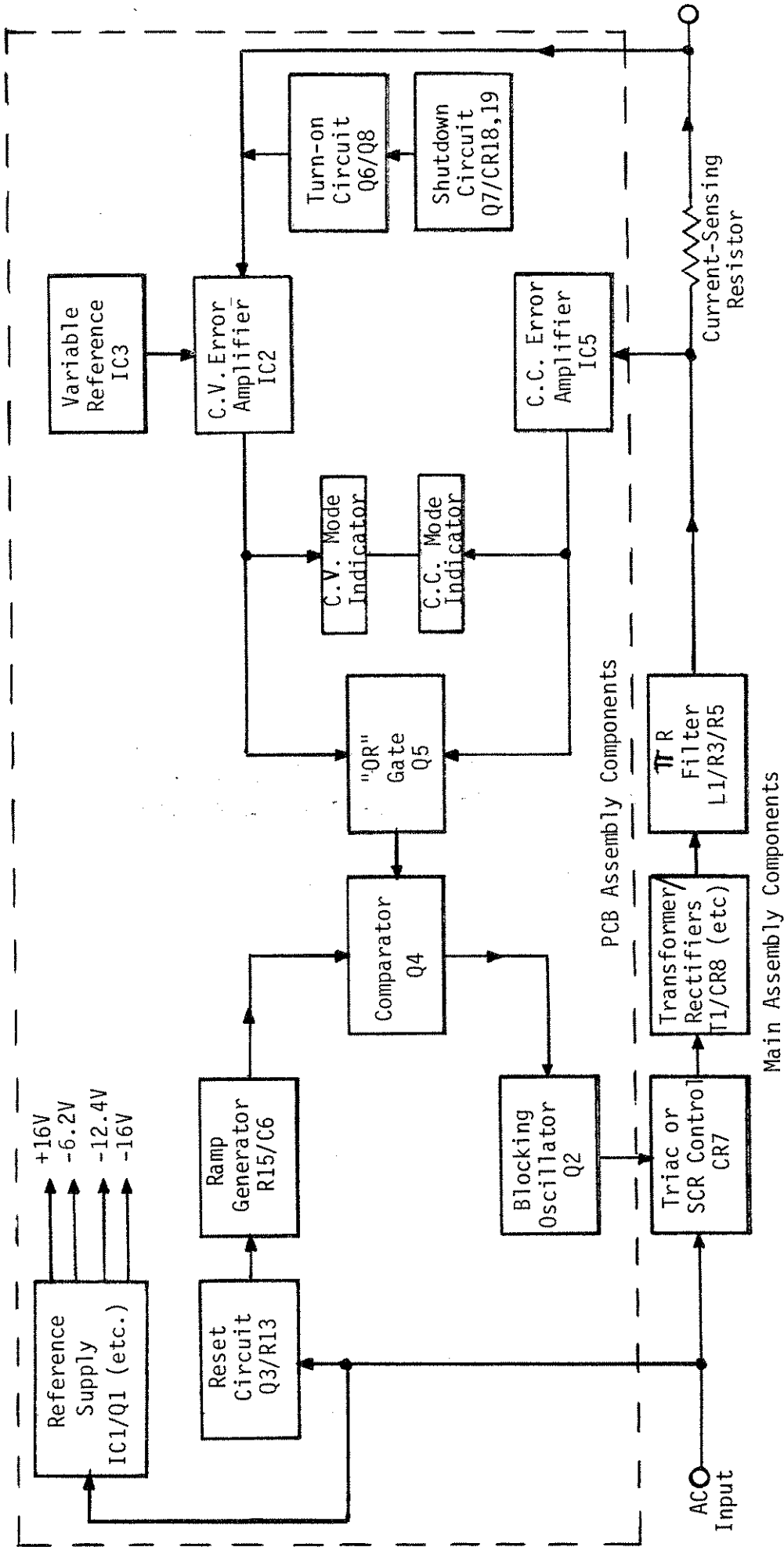

Figure 4-2
DCR-B Functional Block Diagram

4.3 BLOCK-DIAGRAM ANALYSIS (Figure 4-2)

The a-c input voltage is first applied to CR7 (Triac or SCR), which is in series with power transformer T1. CR7 functions with the control circuits to form a feedback loop which prevents a change in output voltage when either the line or load changes.

To accomplish this, the control circuits issue a phase-adjusted firing pulse to CR7 once during each half-cycle of the input a-c voltage. These circuits continuously sample the output voltage, which establishes the precise time at which the firing pulse is to be generated. The phase-controlled a-c voltage is stepped up or down by power transformer T1, and coupled through full-wave rectifier and filtering circuits to the output terminals.

Feedback signals from the output back to CR7 originate in constant-voltage/current error amplifiers IC2/IC5. In the constant-voltage mode, IC2 continuously compares the supply output with a reference voltage generated by a variable reference programming circuit (IC3). A difference in these voltages appears as an error signal, which is delivered to amplifier IC2. This d-c error signal is processed through "OR" gate Q5, and appears at comparator Q4 where it is combined with a ramp voltage, the resultant of which sets the conduction angle of blocking oscillator Q2. The duration of Q2 conduction is directly proportional to the error signal, and its output triggers CR7 into conduction. CR7, then acts as a switch whose firing angle is dependent on the magnitude of d-c error signal, thus controlling the overall supply output.

Similarly, in the constant-current mode, changes in line or load are sensed by R10, in series with the output, amplified by IC5, and applied through gate Q5 to comparator Q4. Output control from this point is essentially the same as in the constant-voltage analysis preceding.

4.4 DETAILED CIRCUIT DESCRIPTION

NOTE

All component/circuit callouts are referenced to PCB schematic diagram Figure 6-1 unless otherwise noted.

4.4.1 Reference Supply

The precisely regulated voltage required for operation of the control circuitry is produced by a reference supply consisting of Zener diodes CR1/CR4, operational amplifier IC1, passing stage Q1, transformer T2 (Figure 6-4) and center-tapped full-wave rectifier CR5/CR6 (Figure 6-4).

The reference supply output appears across a comparison bridge composed of divider R4/R5, Zener CR4, and R6. Error signals are sensed across this bridge

and amplified by IC1. The variable impedance characteristic of passing stage Q1 changes the level of absorbed voltage across the stage, maintaining the output at a precisely controlled negative 12.4 volts (Figure 4-3).

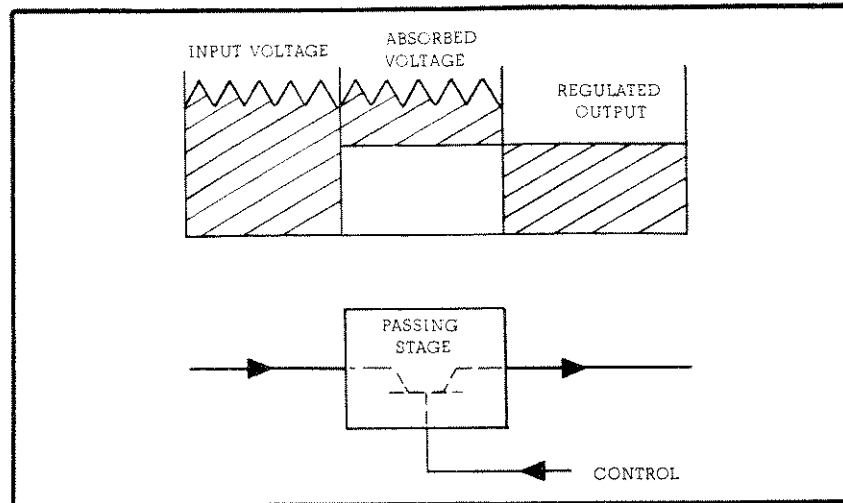

Figure 4-3 Passing-Stage Principle

To illustrate circuit operation, assume an increase in the T2 (Figure 6-4) supply output.

Pin 2 of IC1 will become more negative, and the output at pin 6 more positive, tending to turn Q1 off. The reduction in drive current increases the impedance of Q1, and consequently its absorbed voltage, resulting in precise regulation of reference supply output. Zener CR5 maintains a 20-volt reference to the control circuitry. Zener CR17 and resistor R35 provide a positive 16-volt source.

4.4.2 Voltage-Mode Section

Primary components of this circuit include constant-voltage error amplifier IC2, variable reference programmer IC3, and emitter-follower stage Q5. The circuit functions as follows:

Pin 3 of IC3 is referenced to (+) sense. Front-panel voltage controls R8/R9 (R10/R11 on higher power units) function as variable feedback resistances from IC3 pin 6 to pin 2. The negative 12.4-volt reference through R28/29/30 establishes the desired programming-current range, such that from 0 to 10 volts is applied at pin 6 of IC3.

Pin 4 of IC2 is at virtual d-c ground, and thus the current through R25 can be varied from 0 to 1 milliampere. This current, through R26, programs the supply to the desired output. IC2 pin 5 senses this output, and compares it

to the voltage developed at IC2 pin 4. The resultant is an error signal, amplified by IC2, and coupled to R16 through the emitter of Q5.

To illustrate circuit operation, an increase in system output drives IC2 pin 4 more negative. IC2 pin 11, and thus the Q5 emitter also become more negative, creating the error voltage necessary to retard the firing angle of CR7 through T1/Q2 action as noted in the block-diagram analysis.

4.4.3 Current-Mode Section

The primary component in this section is constant-current amplifier IC5. A reference voltage at IC5-6 is divided down by bridge dividers R46/R47 and R48/R49 to IC5 pins 5 and 4 respectively. The resultant voltages are referenced to the positive output, through a current sensing resistor (Figure 6-4), with R11/R12 (R13/R14 in higher power units) (Figure 6-4) serving as the front-panel current-adjust potentiometers.

The following is an illustration of current-mode operation. If the output current approaches the current-limit setting, the voltage across the sensing resistor becomes more positive. This is seen as a positive error voltage at IC5 pin 5, which is amplified and applied to the IC5 output, pin 10, and on to comparator Q4 as outlined in the block-diagram analysis, paragraph 4.3.

4.4.4 Ramp Generator, Reset Circuit and Comparator

The ramp generator consists of R15 and C6; the reset circuit, Q3 and R13; the comparator, Q4, CR10, R16 and R17. The ramp voltage at the junction of R15/C6 is coupled through CR10 to the base of Q4. This voltage starts at a maximum level, and decreases exponentially until reset by Q3 at 8.3-millisecond intervals. The reset pulse for Q3 is generated by CR5/R1 as follows:

The full-wave rectified a-c input from T2 (Figure 6-4) is impressed across CR5/R1. CR5 clamps the base of Q3 at its zener level, keeping it shut off. As the impressed voltage drops toward zero, the zener voltage follows, causing Q3 to turn on.

Mixer Q4 combines the d-c signal from either the voltage - or current-mode amplifier with the ramp-generator voltage. The varying output of Q4 establishes the conduction angle of blocking oscillator Q2.

4.4.5 Blocking Oscillator Q2

Q2 functions as a switch control, providing the triggering voltage for CR7, proportional to the error signal received from the comparator circuit. The blocking-oscillator circuit functions as follows:

Assume that at a given time, the Q4 d-c emitter voltage is several volts below the reference level provided by the reference-supply circuit (paragraph 4.4.1). At a point when the ramp voltage appearing at the base of Q4 is more negative than that on its emitter, Q4 conducts, driving the base of Q2 positive, causing Q2 to conduct. As its collector current (I_c) increases, regenerative action occurs through pulse transformer T1, forcing Q2 into saturation. I_c continues to increase along the saturation curve until the point at which V_{ce} in-

creases. The T1 voltage then decreases, and thus also the Q2 base current. At this point Q2 comes out of saturation. Because the loop gain is greater than unity in the active region, Q2 quickly is drawn into cutoff. The cycle is then complete.

4.4.6 Turn-On and Shut-Down Circuits

Primary components of the turn-on circuit are Q6, Q8, R32, R33, CR16 and C10. Circuit operation is as follows:

When power is initially applied to the unit, the bases of Q6/Q8 are positive, due to the voltage across C10. Q6 and Q8 are thus in saturation. The resultant negative voltage at the Q6/Q8 collectors maintains voltage-error amplifier IC2 and the blocking oscillator/mixer circuits cut off. This action inhibits the output of the power supply from coming up. As C10 charges, the supply output will increase exponentially. Q6/Q8 gradually come out of saturation until the voltage across C10 reaches the point where they are shut off. The supply is then functioning in its normal manner.

The shut-down circuit, consisting of Q7, R36, R37, CR18/CR19, cuts off the unit output when the cathode of either diode is shorted to the (+) sense connection. The circuit function is to actuate Q7, which turns Q6 and Q8 on. When the short is removed, power supply output returns to its normal function.

4.4.7 Power Section (Figure 6-4)

The input a-c voltage is applied to the primary of power transformer T1 through a Triac or SCR switch (CR7). The output is rectified by a full-wave bridge, and filtered by C-L-C network, with a damping resistor (R3). The filtered dc is then applied to the output terminals.

5. MAINTENANCE

5.1 GENERAL

This section provides troubleshooting data, periodic servicing, and calibration and performance-testing procedures. The troubleshooting data should be used in conjunction with the schematic diagrams (Figures 6-1/6-4) and Section 4 which outlines the principles of operation. In addition, Figures 6-2 and 6-3 physically locate the components referred to in the text. Any questions pertaining to repair should be directed to the nearest Sorensen representative* or to the Service Dept., Sorensen Company, 676 Island Pond Road, Manchester, N. H. 03103. Include the model and serial numbers in any correspondence. Should it be necessary to return a unit to the factory for repair, prior authorization from the Sorensen Company must be obtained.

5.2 PERIODIC SERVICING

Whenever a unit is removed from the line, it should be cleaned, using naphtha or an equivalent solvent on painted surfaces, and a weak solution of soap and warm water for the front panel. Compressed air at a pressure of 5 psi may be used to blow dust from in and around components.

5.3 TROUBLESHOOTING

Table 5-1 provides a list of malfunction symptoms along with a tabulation of the possible cause(s) for each symptom. Note that the failure of a single component may result in a "chain-reaction" effect. As additional aids to troubleshooting, voltage checkpoints have been designated on the printed-circuit schematic diagram, Figure 6-1. X-Y plots, included in Figure 6-1, show typical waveforms developed across a number of selected components.

5.4 CALIBRATION

Following repair, the unit should be recalibrated to insure that replacement components have not appreciably altered performance characteristics. When calibrating, follow sequence of the subsequent steps. Refer to Table 5-3 for unit calibration specifications.

1. Rotate the COARSE and FINE CURRENT controls fully clockwise.
2. Set the unit power to OFF and remove link between terminals 5 and 6. Connect a precision ($\pm 1\%$) 12-K resistor between terminals 4 and 5.
3. Place a precision d-c voltmeter across the output sense leads.
4. Set unit power to ON, and adjust R30 on the printed-circuit board (Fig-

* See final page for list of Sorensen representatives

Table 5-1 DCR-B Troubleshooting

Symptom	Probable Cause
1 No output (voltage mode)	a) Improper input voltage b) Open fuses and circuit breakers* c) Reference voltages (check levels) d) Defective IC2 or IC3 e) Collector-to-emitter short: Q3, Q5, Q6, Q7 or Q8 f) Q2 open or shorted
2 Fuse opens or circuit breaker trips	a) CR7 shorted* b) Input capacitors shorted* c) CR8, CR9, CR10, CR11 shorted or open*
3 High output voltage (meter pointer pegs)	a) Sensing or programming leads or link open* b) Defective IC2 or IC3 c) Q4 shorted collector-to-emitter d) Q5 open collector-to-emitter
4 No output (current mode), or unit will not current-limit	a) Defective IC5 b) C14 shorted c) CR13 open d) Shorted COARSE CURRENT potentiometer* e) Collector-to-emitter short: Q3, Q5, Q6, Q7 or Q8 f) Q2 open or shorted
5 Output oscillates (current mode)	Potentiometer R45 on unit PCB improperly adjusted

ure 6-2) until the voltmeter indicates the full output-voltage rating of the supply.

5. Set power to OFF. Disconnect the voltmeter and 12-K resistor, and replace link between terminals 5 and 6.

5.4.2 Current-Mode Section, Limit Settings

1. Set unit power to OFF. Short output terminals and set current and voltage controls fully clockwise.
2. Set potentiometer R54 on the PCB fully counterclockwise (see Figure 6-2, page 6-5). Set power to ON and adjust R54 to the limit stated in specifications Table 5-3, upper limit set point. Set power to OFF, and remove output short.
3. To preset for zero output current, repeat step 1. preceding, except set voltage and current controls fully counterclockwise. Set power to ON, and adjust R53 until current-meter pointer just starts to move. This is the proper set point.

*Chassis components (ref. Figure 6-4)

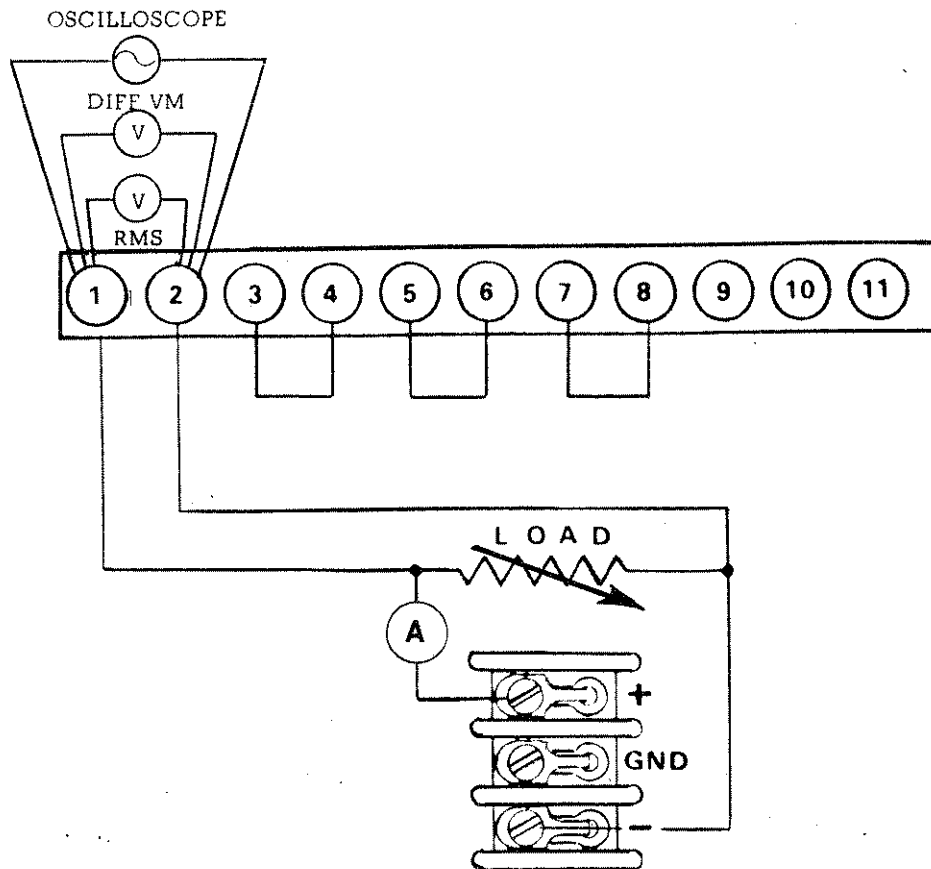

Figure 5-1 Performance Test Setup

5.5 PERFORMANCE TESTING

Sensitive instruments like the DCR-B require rigorous testing methods if a true performance evaluation is to be made. Wherever possible, twisted leads should be used with test equipment to reduce stray pickup. At the power-supply terminal board, these leads must be firmly held by the terminal screws. Alligator clips and similar types of connectors are not suitable. Note that the output specifications are applicable at the rear terminals only. (Front-panel binding posts may introduce errors of sufficient magnitude to influence measurements.) In addition, grounding techniques in which more than one device in the setup is grounded may introduce extraneous ripple that, although unrelated to the power-supply-output ripple, is displayed on the test oscilloscope.

5.5.1 Voltage-Mode Regulation and Ripple

To check voltage-mode regulation and ripple, proceed as follows:

1. Connect a sensitive differential or digital voltmeter and an RMS meter across unit output terminals per Figure 5-1. If a differential voltmeter is used, set internal voltage equal to the unit's rated output.

Use an autotransformer with a current rating that exceeds the maximum unit input current called out in the unit specifications (front of manual).

NOTE

Input devices such as autotransformers or line regulators can distort the input wave sufficiently to adversely affect performance measurements.

2. Apply low-line input per specifications, and then set unit circuit breaker to ON.
3. Rotate COARSE CURRENT control fully clockwise.
4. Use COARSE and FINE VOLTAGE controls to obtain rated output.
5. Simultaneously increase input voltage and load until voltage is at high line and load is drawing rated current. Output voltage and ripple should not deviate more than limits specified in Table 5-3.
6. Disconnect test setup.

5.5.2 Current-Mode Regulation

To check current-mode regulation, proceed as follows:

1. At no load, adjust output to maximum rated voltage, and set COARSE CURRENT control fully clockwise.
2. Connect a sense resistor (Table 5-2) in series with a variable load across the output terminals.
3. Connect input power at low line per unit specifications. Apply load until rated current of supply is reached. Adjust COARSE CURRENT control until CURRENT mode indicator glows brightly. Adjust COARSE VOLTAGE control fully clockwise.
4. Connect a differential voltmeter across the sensing resistor, and note the indication.
5. Simultaneously increase input voltage and load until input voltage is at high line, and compliance voltage is zero. Note indication on differential voltmeter. Change in voltmeter reading should be divided by sense resistor value to obtain regulation in milliamperes. Limits are provided in Table 5-3.

5.5.3 Transient Response

Test for transient response as follows:

1. Connect an oscilloscope across the unit output terminals.
2. Set unit POWER switch to ON. Adjust COARSE VOLTAGE control for rated

output, and COARSE CURRENT control fully clockwise.

3. Apply half load, and then abruptly apply full load (or switch from full load to half load). Return to steady-state operation should occur within 50 milliseconds (typical).

NOTE

Load switching time should be less than 3 milliseconds.

Table 5-2
Sensing Resistor Values (Current-Mode Regulation Check)

DCR MODEL	SENSE RESISTOR (Ohms)
10-40B	0.01, 50W
20-25B	0.01, 50W
40-13B	0.01, 50W
60-9B	0.1, 25W
80-6B	0.1, 25W
150-3B	0.1, 25W
300-1.5B	1.0, 10W
600-.75B	1.0, 10W

Table 5-3
Unit Calibration Specifications

DCR Model	Regulation		Ripple Volt. Mode (mV)	Transient Deviation (Volts)	Maximum Compliance (Vdc)	Cur. Mode Upper Lim. Set Pt. (A)
	Voltage Mode (mV)	Current Mode (mA)				
10-40B	3	100	65	0.6	10	48
20-25B	6	62.5	65	1.2	20	30
40-13B	12	32.5	90	2.4	40	15.5
60-9B	18	22.5	125	3.6	60	10.5
80-6B	24	15	150	4.8	80	7.5
150-3B	45	7.5	300	9.0	150	3.6
300-1.5B	90	3.75	700	18	300	1.75
600-.75B	180	2	1200	36	600	0.9

5.6 HI-POT TEST PROCEDURE

It is recommended that this test be performed only if a component has been repaired or replaced which could affect the dielectric capability of the unit.

Note: If unit has been in service for an extended period, it should first be cleaned of dust or any other accumulations.

A. Test Limits:

Input - 1300Vdc
Output - 900Vdc

B. Test Equipment Required:

Hi-Pot Tester - ElectroSpace Model 650 "Megpot" or equivalent.
Jumpers/Clip Leads as required.

C. Equipment Set-up:

1. Isolate unit input line cord from power source and chassis.
2. Connect input terminals TB1-1 and -3 together.
3. Connect output terminals TB2-1 and -3 together.
4. Set Hi-Pot tester switch to ON.

D. Input Test:

1. Connect the unit output terminals to chassis ground.
2. Set the trip current control on the Hi-Pot tester to 100 microamperes and voltage control to 0.
3. Connect the Hi-Pot tester from the input terminals to chassis ground.
4. Gradually increase the Hi-Pot voltage from 0 volts to input test limit (paragraph A. preceding).
5. Hold maximum specified level for at least five seconds. No breakdown shall occur during test.
6. Decrease Hi-Pot voltage to 0 volts.



Charged capacitors must not be shorted to ground to remove the charge. This voltage must be discharged slowly through a 47K, 2W resistor. Failure to follow this instruction can result in damage to semiconductors resulting in immediate or subsequent unit failure.

7. Disconnect Hi-Pot leads from power supply input terminals.
8. Remove output terminal ground.

E. Output Test:

1. Connect the unit input terminals to chassis ground.
2. Set the trip current control on the Hi-Pot tester to 100 micro-amperes, and output voltage control to 0 volts.
3. Connect the Hi-Pot tester from the output terminals to chassis ground.
4. Gradually increase the Hi-Pot voltage from 0 volts to the output test limit (paragraph A. preceding).
5. Hold maximum specified level for at least five seconds. No breakdown shall occur during test.
6. Decrease Hi-Pot voltage to 0 volts.



Charged capacitors must not be shorted to ground to remove the charge. This voltage must be discharged slowly through a 47K, 2W resistor. Failure to follow this instruction can result in damage to semiconductors resulting in immediate or subsequent unit failure

7. Disconnect Hi-Pot leads from power supply output.
8. Remove input terminal ground.
9. Remove input and output terminal jumpers.

6. DRAWINGS and PARTS LISTS

6.1 GENERAL

This section provides a coded replaceable parts list keyed to both the schematic diagrams and parts location diagrams (Figures 6-1 through 6-4). Tables 6-1 and 6-2 summarize the part numbers of all identified components.

Figure 6-1 is the printed-circuit board (PCB) schematic diagram. As an aid to troubleshooting, several checkpoints are called out, with an accompanying chart depicting typical waveforms appearing at those points.

Figures 6-2 and 6-3 physically locate parts on the PCB and (typical) chassis frame respectively.

Figure 6-4 represents the 150-volt chassis (final assembly) schematic diagram, as typical of all DCR-B systems. Primary differences occur in the output section, as evidenced by the 10-volt and 600-volt representations, included on the drawing. Figure 6-4 shows 115/208/220/230V input connections.

6.2 PARTS LIST COLUMN HEADINGS DEFINED

Tables 6-1 and 6-2 identify parts for all units in the series, tabulated as follows:

6.2.1 Circuit Symbol;

Component identification on the respective schematic diagram,

6.2.2 DCR-B Model;

Separate column for each model in the series,

6.2.3 Description;

Basic item, its value and electrical characteristics,

6.2.4 Sorensen P/N;

The number to be used when ordering parts. Call Sorensen at (603) 668-4500, or order directly from:

Sorensen Company
Replacement Parts Dept.
676 Island Pond Road
Manchester, N.H. 03103

6.2.5 Mfr., Type;

The basic group or series number under which the part is listed by the manufacturer. The coded identifications of representative manufacturers are summarized as follows:

AB	Allen Bradley Co.
AC	Acushnet Capacitor Co.
AM	Ammons Instrument Co.
BNS	Bourns, Incorporated
BUS	Bussman Mfg./Div. Mc-Graw Edision
CD	Cornell-Dublier Corp.
CG	Corning Glass Works
CL	Clarostat Corp.
CTS	CTS Corporation
ELA	Electra/Midland
EMC	Electromotive Manufacturing Co.
FD	Fairchild Semiconductor
GE	General Electric Co.
GI	General Illuminating Co.
IND	Industrial Devices
IR	International Rectifier Co.
LF	Littelfuse Corporation
MA	Motorola
MAL	P. R. Mallory Co.
RAM	RAM Electronics
RCA	RCA Corporation
RCL	RCL Electronics
SAN	Sangamo Electric
SE	Seacor, Incorporated
SEM	Semtech Corporation
SP	Sprague Electric
SR	Sorensen Company
ST	Solitron Devices
STM	STM Corporation
TI	Texas Instrument Co.
WH	Westinghouse Semiconductor Division
WL	Ward-Leonard

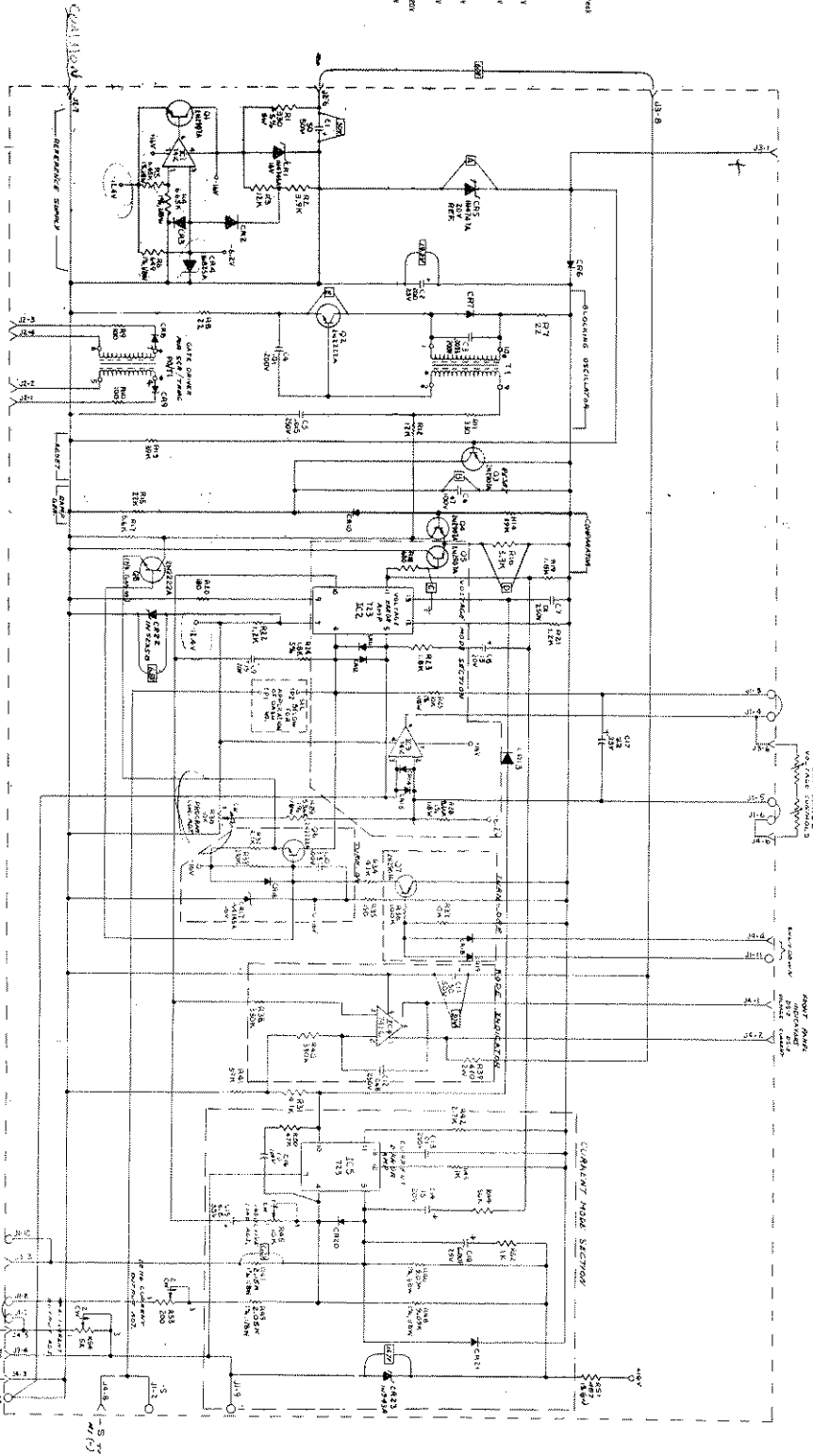
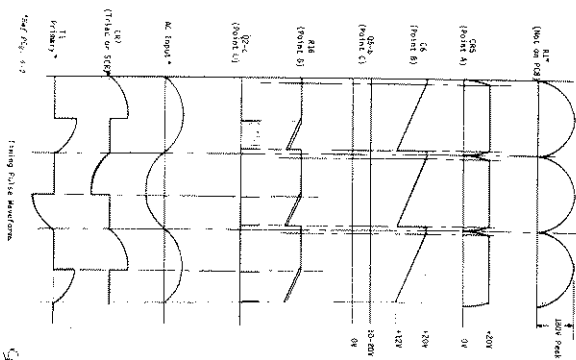

UNIT	RES	RES	RES	RES	RES
01-10	100K	100K	100K	100K	100K
01-11	100K	100K	100K	100K	100K
01-12	100K	100K	100K	100K	100K
01-13	100K	100K	100K	100K	100K
01-14	100K	100K	100K	100K	100K
01-15	100K	100K	100K	100K	100K
01-16	100K	100K	100K	100K	100K
01-17	100K	100K	100K	100K	100K
01-18	100K	100K	100K	100K	100K
01-19	100K	100K	100K	100K	100K
01-20	100K	100K	100K	100K	100K
01-21	100K	100K	100K	100K	100K
01-22	100K	100K	100K	100K	100K
01-23	100K	100K	100K	100K	100K
01-24	100K	100K	100K	100K	100K
01-25	100K	100K	100K	100K	100K
01-26	100K	100K	100K	100K	100K
01-27	100K	100K	100K	100K	100K
01-28	100K	100K	100K	100K	100K
01-29	100K	100K	100K	100K	100K
01-30	100K	100K	100K	100K	100K
01-31	100K	100K	100K	100K	100K
01-32	100K	100K	100K	100K	100K
01-33	100K	100K	100K	100K	100K
01-34	100K	100K	100K	100K	100K
01-35	100K	100K	100K	100K	100K
01-36	100K	100K	100K	100K	100K
01-37	100K	100K	100K	100K	100K
01-38	100K	100K	100K	100K	100K
01-39	100K	100K	100K	100K	100K
01-40	100K	100K	100K	100K	100K
01-41	100K	100K	100K	100K	100K
01-42	100K	100K	100K	100K	100K
01-43	100K	100K	100K	100K	100K
01-44	100K	100K	100K	100K	100K
01-45	100K	100K	100K	100K	100K
01-46	100K	100K	100K	100K	100K
01-47	100K	100K	100K	100K	100K
01-48	100K	100K	100K	100K	100K
01-49	100K	100K	100K	100K	100K
01-50	100K	100K	100K	100K	100K
01-51	100K	100K	100K	100K	100K
01-52	100K	100K	100K	100K	100K
01-53	100K	100K	100K	100K	100K
01-54	100K	100K	100K	100K	100K
01-55	100K	100K	100K	100K	100K
01-56	100K	100K	100K	100K	100K
01-57	100K	100K	100K	100K	100K
01-58	100K	100K	100K	100K	100K
01-59	100K	100K	100K	100K	100K
01-60	100K	100K	100K	100K	100K
01-61	100K	100K	100K	100K	100K
01-62	100K	100K	100K	100K	100K
01-63	100K	100K	100K	100K	100K
01-64	100K	100K	100K	100K	100K
01-65	100K	100K	100K	100K	100K
01-66	100K	100K	100K	100K	100K
01-67	100K	100K	100K	100K	100K
01-68	100K	100K	100K	100K	100K
01-69	100K	100K	100K	100K	100K
01-70	100K	100K	100K	100K	100K
01-71	100K	100K	100K	100K	100K
01-72	100K	100K	100K	100K	100K
01-73	100K	100K	100K	100K	100K
01-74	100K	100K	100K	100K	100K
01-75	100K	100K	100K	100K	100K
01-76	100K	100K	100K	100K	100K
01-77	100K	100K	100K	100K	100K
01-78	100K	100K	100K	100K	100K
01-79	100K	100K	100K	100K	100K
01-80	100K	100K	100K	100K	100K
01-81	100K	100K	100K	100K	100K
01-82	100K	100K	100K	100K	100K
01-83	100K	100K	100K	100K	100K
01-84	100K	100K	100K	100K	100K
01-85	100K	100K	100K	100K	100K
01-86	100K	100K	100K	100K	100K
01-87	100K	100K	100K	100K	100K
01-88	100K	100K	100K	100K	100K
01-89	100K	100K	100K	100K	100K
01-90	100K	100K	100K	100K	100K
01-91	100K	100K	100K	100K	100K
01-92	100K	100K	100K	100K	100K
01-93	100K	100K	100K	100K	100K
01-94	100K	100K	100K	100K	100K
01-95	100K	100K	100K	100K	100K
01-96	100K	100K	100K	100K	100K
01-97	100K	100K	100K	100K	100K
01-98	100K	100K	100K	100K	100K
01-99	100K	100K	100K	100K	100K
01-100	100K	100K	100K	100K	100K

- NOTES
1. ALL DIMENSIONS SPECIFIED IN THIS DRAWING ARE IN MILLIMETERS.
 2. UNLESS OTHERWISE SPECIFIED, ALL DIMENSIONS ARE TO CENTER UNLESS OTHERWISE SPECIFIED.
 3. DIMENSIONS TO CENTER UNLESS OTHERWISE SPECIFIED.
 4. DIMENSIONS TO CENTER UNLESS OTHERWISE SPECIFIED.
 5. DIMENSIONS TO CENTER UNLESS OTHERWISE SPECIFIED.

DWG. E588300 REV. E (Special)

Figure 6-1
DCR-B PCB Schematic Diagram
(All Models)

n

o

o

a 6-
a Pat
B As

Table
Replaceable
DCR-B PCI

CIRCUIT SYMBOL	DESCRIPTION	SORENSEN PART NUMBER	MANUFACTURER, TYPE
	<u>CAPACITORS</u> (μ F unless noted)		
C1	50, 50V	24-2280-12	SP, TE 1307
C2	200, 25V	24-2472	SP, 30D
C3	0.0033, 200V	24-2409-4	AX, V146XR
C4	0.01, 200V	24-2409-7	AX, V146XR
C5	0.015, 250V	24-2015-3	SE, MMK
C6	0.47, 100V	24-2037-15	SE, MMK
C7	0.01, 250V	24-2015-3	SP, 150D
C8	15, 20V	586385-5	SP, 150D
C9	15, 20V	586385-6	SE, Type 105
C10	3.3, 100V	587626-13	SP, TE 1307
C11	50, 50V	24-2280-12	SE, MMK
C12	0.068, 250V	24-2015-11	SE, MMK
C13	0.01, 250V	24-2015-1	SE, MMK
C14	15, 20V	586385-5	SP, 150D
C15	6.8, 35V	586058-17	SP
C16	1.0, 100V	24-2037-19	SE, MMK
C17	22, 35V	586058-23	SP
C18	6.8, 25V	235-7188P13	SP, T360
	<u>DIODES</u>		
CR1	1N4745A, Zener, 16V	588102-12	MA
CR2	S12	587565-2	SEM
CR3	S12	587565-2	SEM
CR4	1N825A, Zener, 6.2V	588105-3	MA
CR5	1N4747A, Zener, 20V	588102-13	MA
CR6	S12	587565-2	SEM
CR7	S12	587565-2	SEM
CR8	S12	587565-2	SEM
CR9	S12	587565-2	SEM
CR10	S12	587565-2	SEM
CR11	S12	587565-2	SEM
CR12	S12	587565-2	SEM
CR13	S12	587565-2	SEM
CR14	S12	587565-2	SEM
CR15	S12	587565-2	SEM
CR16	S12	587565-2	SEM
CR17	1N4745A, Zener, 16V	588102-12	MA
CR18	S12	587565-2	SEM
CR19	S12	587565-2	SEM
CR20	S12	587565-2	SEM
CR21	S12	587565-2	SEM
CR22	1N5235B, Zener, 6.8V	588101-10	MA
CR23	1N943A, Zener, 11.7V	588105-7	MA
	<u>INTEGRATED CIRCUITS</u>		
IC1	741C	586372-2	FD, UA741TC
IC2	723	586062-1	MA, MC1723CL
IC3	741C	586372-2	FD, UA741TC
IC4	741C	586372-2	FD, UA741TC
IC5	723	586062-1	MA, MC1723CL
	<u>TRANSISTORS</u>		
Q1	2N2907A	386-7249P58	MA
Q2	2N2222A	386-7249P57	MA
Q3	2N2907A	386-7249P58	MA
Q4	2N2907A	386-7249P58	MA
Q5	2N2907A	386-7249P58	MA
Q6	2N2222A	386-7249P57	MA
Q7	2N2907A	386-7249P58	MA
Q8	2N2222A	386-7249P57	MA
	<u>RESISTORS</u> (Ohms, 1/2W, \pm 10% unless noted)		
R1	330, 3W, \pm 5%	27-397-85	AB, EB
R2	3.9K	280-1145P95	AB, EB
R3	12K	280-1145P113	ELA, MF 4
R4	6.65K, 1/8W, \pm 1%	586055-188	ELA, MF 4
R5	6.65K, 1/8W, \pm 1%	586055-188	ELA, MF 4
R6	649, 1/8W, \pm 1%	586055-65	ELA, MF 4
R7	22	280-1145P14	AB, EB
R8	22	280-1145P14	AB, EB
R9	100	280-1145P38	AB, EB
R10	100	280-1145P38	AB, EB
R11	330	280-1145P56	AB, EB
R12	12K	280-1145P113	AB, EB
R13	39K	280-1145P131	AB, EB
R14	39K	280-1145P131	AB, EB
R15	22K	280-1145P122	AB, EB
R16	3.3K	280-1145P92	AB, EB
R17	5.6K	280-1145P101	AB, EB
R18	680	280-1145P68	AB, EB
R19	1.8K	280-1145P83	AB, EB
R20	180	280-1145P47	AB, EB
R21	1.2K	280-1145P77	AB, EB
R22	1.2K	280-1145P77	AB, EB
R23	1.8K	280-1145P83	AB, EB
R24	1.8K	280-1145P83	AB, EB
R25	10K, 1/8W, \pm 1%	586055-122	ELA, MF 4
R26A (10V)	10K, \pm 1%	588078-1	ELA, MF Series

e 6-1
e Parts List
B Assembly

CIRCUIT SYMBOL	DESCRIPTION	SORENSEN PART NUMBER	MANUFACTURER, TYPE
	RESISTORS (Cont'd)		
R26A (20V)	20K, ±1%	588078-2	ELA,MF Series
R26A(40V)	40K, ±1%	588078-3	ELA,MF Series
R26A(60V)	60K, ±1%	588078-4	ELA,MF Series
R26A(80V)	80K, ±1%	588078-5	ELA,MF Series
R26A(150V)	150K, ±1%	588078-6	ELA,MF Series
R26C&F (300V)	150K, ±1% (2 Req'd)	588078-6	ELA,MF Series
R26B,D,E, &F (600V)	150K, ±1% (4 Req'd)	588078-6	ELA,MF Series
R28	8.66K, 1/8W, ±1%	586055-119	ELA,MF 4
R29	53.6K, 1/8W, ±1%	586250-157	ELA,MF 4
R30	10K, Variable	586370-16	BNS, 3389P-1-103
R31	4.7K	280-1145P98	AB,EB
R32	4.7K	280-1145P98	AB,EB
R33	270K	280-1145P161	AB,EB
R34	47K	280-1145P134	AB,EB
R35	150	280-1145P44	AB,EB
R36	100K	280-1145P146	AB,EB
R37	10K	280-1145P110	AB,EB
R38	330K	280-1145P164	AB,EB
R39	470, 2W	280-1147P62	AB,HB
R40	330K	280-1145P164	AB,EB
R41	39K	280-1145P131	AB,EB
R42	2.7K	280-1145P89	AB,EB
R43	1K	280-1145P74	AB,EB
R44	56K	280-1145P137	AB,EB
R45	10K, Variable	586370-16	BNS, 3389-1-103
R46	9.09K, 1/8W, ±1%	586055-120	ELA,MF 4
R47	2.15K, 1/8W, ±1%	586055-90	ELA,MF 4
R48	9.09K, 1/8W, ±1%	586055-120	ELA,MF 4
R49	2.05K, 1/8W, ±1%	586055-89	ELA,MF 4
R50	47K	280-1145P134	AB,EB
R51	487, 1/8W, ±1%	586250-59	ELA,MF 4
R52	1K	280-1145P74	AB,EB
R53	200, Variable	586370-11	BNS, 3389P-1-201
R54	5K, Variable	586370-15	BNS, 3389P-1-502
	TRANSFORMER		
T1	Pulse	586897-1	SR
	MISCELLANEOUS		
	Printed-Circuit Board Ass'y:		
	10V	588176-1	SR
	20V	588176-2	SR
	40V	588176-3	SR
	60V	588176-4	SR
	80V	588176-5	SR
	150V	588176-6	SR
	300V	588176-7	SR
	600V	588176-8	SR
	PCB Connectors		
J1	11-Terminal Strip	586971-1	Kulka, 670A
J2	AC Inputs	586288-6	Motex, 09-52-3084
J3	DC Inputs	586288-6	Motex, 09-52-3084
J4	DC inputs	586288-6	Motex, 09-52-3084

0

0

0

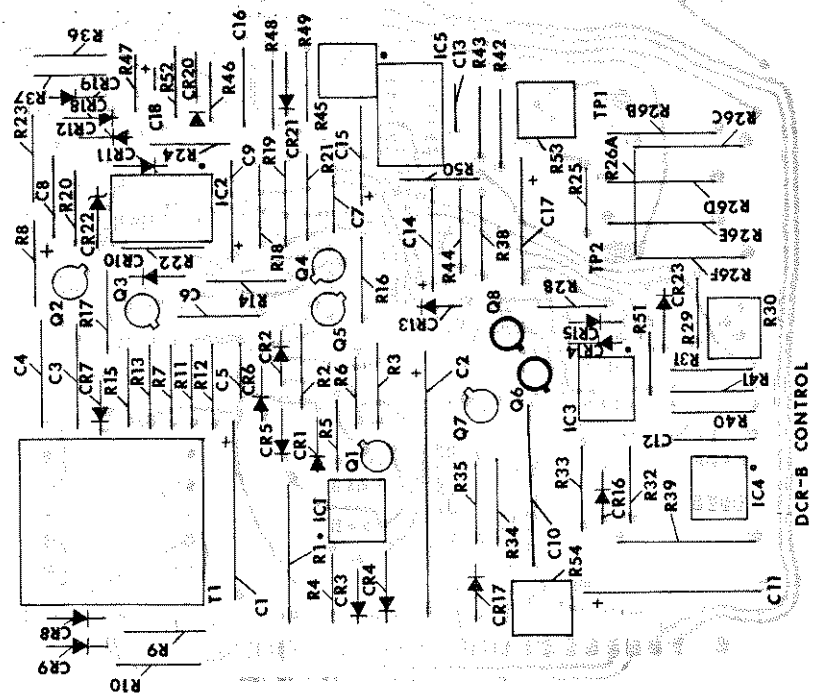
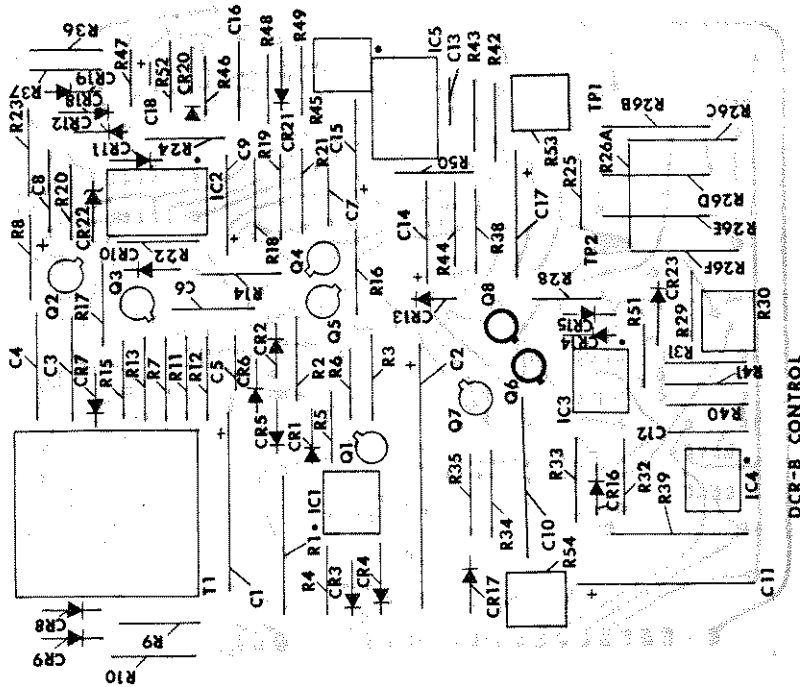

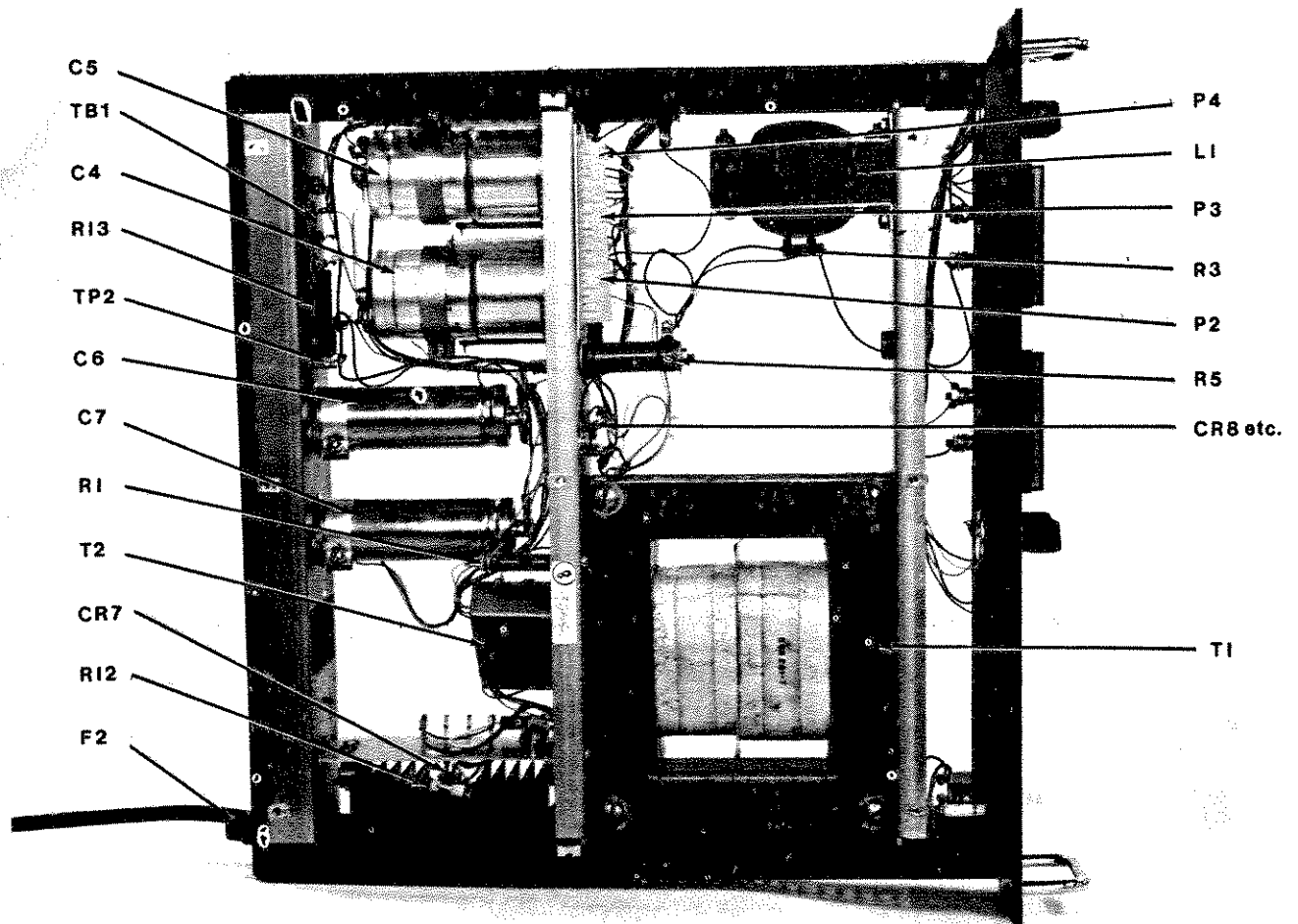

Figure 6-3
 Component Layout, Typical Assembly
 500 Watt Series

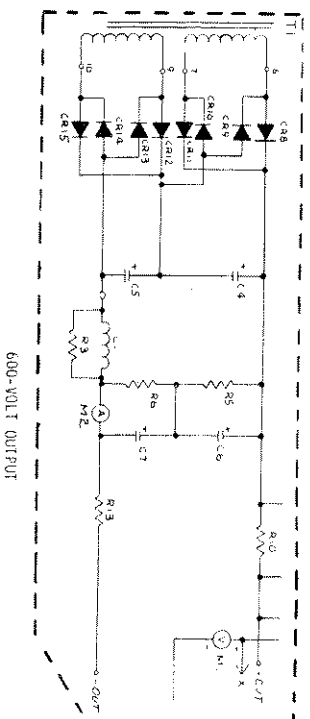
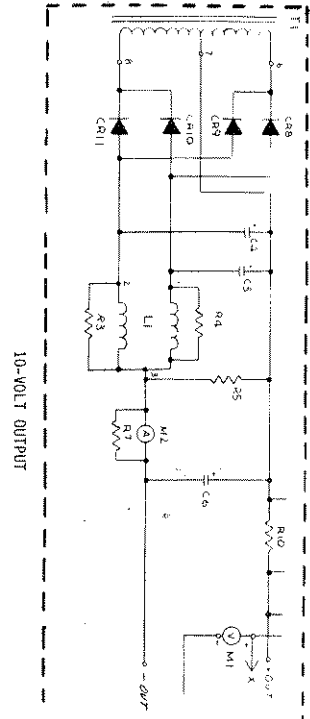
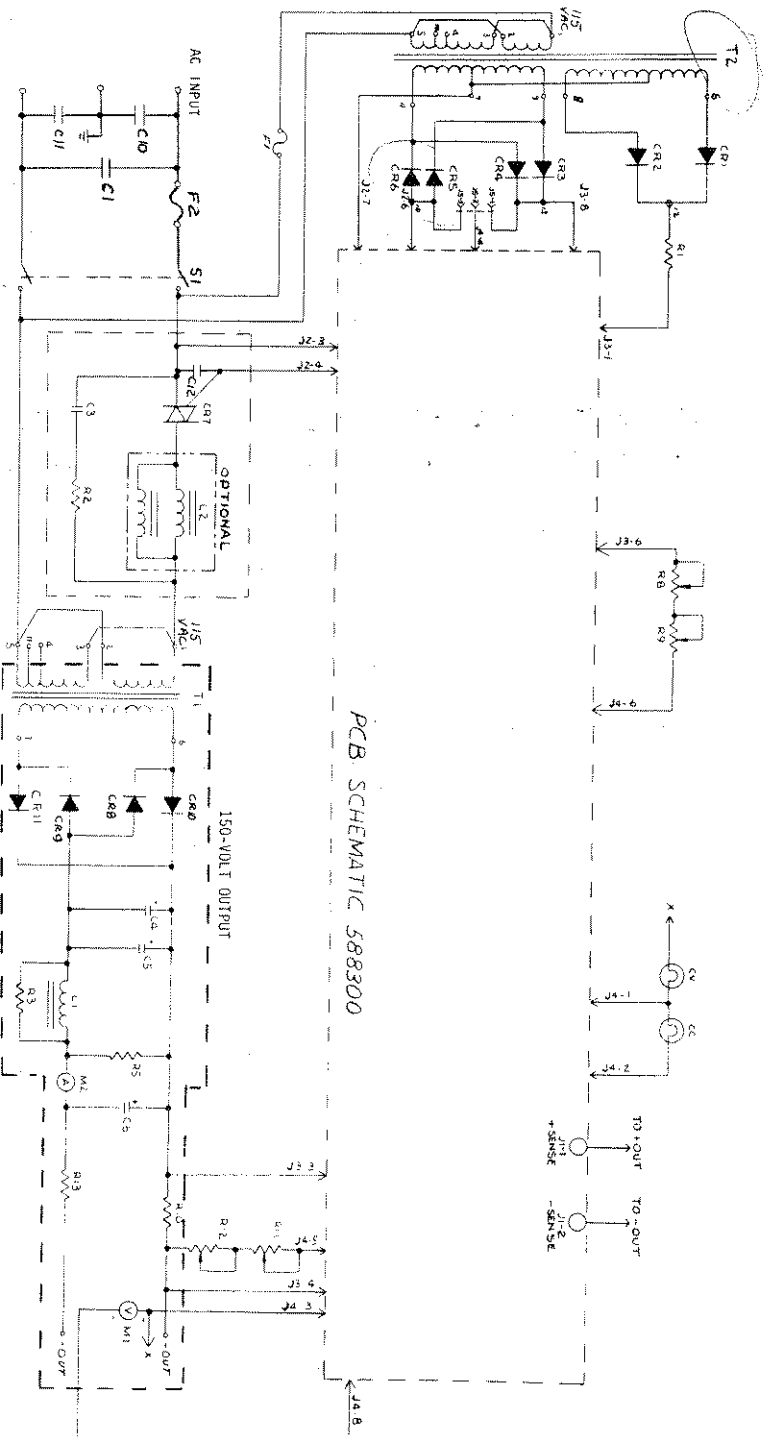
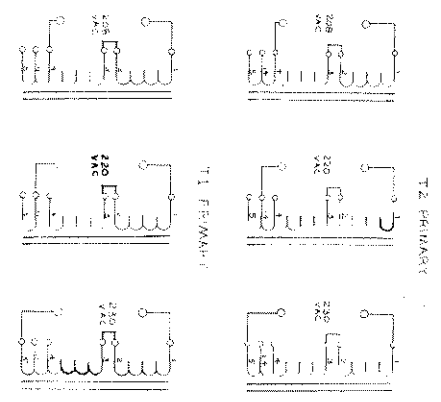

Figure 6-4
DCR-B Main Assembly Schematic Diagram
(Typical 500 Watt)

6-7/6-8

Table 6-2
Replaceable Parts List
DCR-B Main Assembly, 500-Watt Series

CIRCUIT SYMBOL	DCR-B MODEL								DESCRIPTION	SORENSEN PART NUMBER	MANUFACTURER, TYPE
	10-40	20-25	40-13	60-9	80-6	150-3	300-15	600-75			
									Capacitors (uF unless noted)		
C1	x	x	x	x	x	x	x	x	0,10, 600V	24-2110-13	CD, PKM
C2	x	x	x	x	x	x	x	x	Not used		
C3	x	x	x	x	x	x	x	x	0.01, 600V	24-2110-7	CD, PKM
C4	x								32,000, 15V	587193-3	SAN, 100
		x							9,000, 25V	587193-1	SAN, 100
			x						11,000, 50V	24-2595-3	CD, FAH
				x					6,500, 75V	24-2593-1	CD, FAH
					x				4,200, 100V	24-2446-4	SP, 32D
						x			1,100, 200V	588085-5	MAL, CG
							x		510, 400V	588084-5	MAL, CG
								x	230, 100V	588084-3	MAL, CG
C5	x								32,000, 15V	587193-3	SAN, 100
		x							9,000, 25V	587193-1	SAN, 100
			x						11,000, 50V	24-2595-3	CD, FAH
				x					6,500, 75V	24-2593-1	CD, FAH
					x				4,200, 100V	24-2446-4	SP, 32D
						x			1,100, 200V	588085-5	MAL, CG
							x		Not used		
								x	230, 100V	588084-3	MAL, CG
C6	x								110,000, 15V	24-2594-2	CD, FAH
		x							66,000, 25V	24-2544-9	SP, 32D
			x						19,000, 50V	24-2595-4	CD, FAH
				x					6,500, 75V	24-2593-1	CD, FAH
					x				4,200, 100V	24-2446-4	SP, 32D
						x			1,100, 200V	588085-5	MAL, CG
							x		510, 400V	588084-5	MAL, CG
								x	230, 100V	588084-3	MAL, CG
C7	x	x	x	x	x	x	x		Not used		
								x	230, 100V	588084-3	MAL, CG
C8	x	x	x	x	x	x	x	x	Not used		
C9	x	x	x	x	x	x	x	x	Not used		
C10	x	x	x	x	x	x	x	x	.10, 600V	24-2110-13	AC, V146XR
C11	x	x	x	x	x	x	x	x	.10, 600V	24-2110-13	AC, V146XR
C12	x	x	x	x	x	x	x	x	.10, 200V	24-2409-13	AC, V146XR
									Diodes (Silicon Rectifier unless noted)		
CR1	x	x	x	x	x	x	x	x	S16	587565-4	SEM
CR2	x	x	x	x	x	x	x	x	S16	587565-4	SEM
CR3	x	x	x	x	x	x	x	x	S12	587565-2	SEM
CR4	x	x	x	x	x	x	x	x	S12	587565-2	SEM
CR5	x	x	x	x	x	x	x	x	S12	587565-2	SEM
CR6	x	x	x	x	x	x	x	x	S12	587565-2	SEM
CR7*	x	x	x	x	x	x	x	x	T6411D (TRIAC)	588080-5	RCA
CR8	x	x	x						1N1184A	587382-2	WH
				x	x				1N1202A	587393-2	WH
						x			3S14	587566-3	SEM
							x		3S18	587566-5	SEM
								x	S18	587565-5	SEM
CR9	x	x	x						1N1184A	587382-2	WH
				x	x				1N1202A	587393-2	WH
						x			3S14	587566-3	SEM
							x		3S18	587566-5	SEM
								x	S18	587565-5	SEM

* See P6-12, M1/M2/M3 options

Table 6-2
 Replaceable Parts List
 DCR-B Main Assembly, 500-Watt Series

CIRCUIT SYMBOL	DCR-B MODEL								DESCRIPTION	SORENSEN PART NUMBER	MANUFACTURER, TYPE
	10-40	20-25	40-13	60-9	80-6	150-3	300-1.5	600-1.5			
									<u>Diodes (Silicon Rectifier unless noted) (cont'd)</u>		
CR10	x	x	x		x	x			1N1184A 1N1202A 3S14 3S18 S18	587382-2 587393-2 587566-3 587566-5 587565-5	WH WH SEM SEM SEM
CR11	x	x	x		x	x			1N1184A 1N1202A 3S14 3S18 S18	587382-2 587393-2 587566-3 587566-5 587565-5	WH WH SEM SEM SEM
CR12	x	x	x	x	x	x	x	x	Not used S18	587565-5	SEM
CR13	x	x	x	x	x	x	x	x	Not used S18	587565-5	SEM
CR14	x	x	x	x	x	x	x	x	Not used S18	587565-5	SEM
CR15	x	x	x	x	x	x	x	x	Not used S18	587565-5	SEM
									<u>Pilot Lamps</u>		
DS1	x	x	x	x	x	x	x	x	Power	43-357	IND
DS2	x	x	x	x	x	x	x	x	Voltage	43-358	GI
DS3	x	x	x	x	x	x	x	x	Current	43-358	GI
XF1	x	x	x	x	x	x	x	x	Fuseholder	587878-4	BUS
XF2	x	x	x	x	x	x	x	x	Fuseholder	343-1011P2	BUS
									<u>Fuses</u>		
F1*	x	x	x	x	x	x	x	x	0.2A, 250V, (SB)	42-1203	BUS, MDL15
F2*	x	x	x	x	x	x	x	x	15A, 250V	42-1811	BUS, ABC15
									<u>Choke Assembly</u>		
L1	x								DC	588208-1	SR
		x							DC	588208-2	SR
			x						DC	588209-1	SR
				x					DC	588209-2	SR
					x				DC	588209-3	SR
						x			DC	588229-1	SR
							x		DC	588209-4	SR
L2	x	x	x	x	x	x	x	x	DC RFI (Optional)	588207-1 588181-1	SR SR

* See P6-12, M1/M2/M3 options

Table 6-2
Replaceable Parts List
DCR-B Main Assembly, 500-Watt Series

CIRCUIT SYMBOL	DCR-B MODEL								DESCRIPTION	SORENSEN PART NUMBER	MANUFACTURER, TYPE
	10-40	20-25	40-13	60-9	80-6	150-3	300-1.5	600-.75			
M1	x								<u>Panel Meters</u> (VM)	94-579-1 94-579-2 94-579-3 94-579-4 94-579-5 94-579-6 94-579-7 94-579-8	AM, AR-2 AM, AR-2 AM, AR-2 AM, AR-2 AM, AR-2 AM, AR-2 AM, AR-2 AM, AR-2
M2	x								(Ammeter)	94-462-10 94-462-6 94-462-4 94-464-3 94-462-2 94-462-1 94-462-11 94-462-12	AM, AR-2 AM, AR-2 AM, AR-2 AM, AR-2 AM, AR-2 AM, AR-2 AM, AR-2 AM, AR-2
R1	x	x	x	x	x	x	x	x	<u>Resistors (ohms, 1/2W, ±10% unless noted)</u> 1.5K, 10W	27-541	WL, 10F1500
R2	x	x	x	x	x	x	x	x	150, 2W	280-1147P44	AB, HB
R3	x								0.68, 6.5W, ±5% 1.5, 12.5W, ±5% 1.0, 6.5W, ±5% 2.2, 6.5W, ±5% 3.3, 6.5W, ±5% 15, 6.5W, ±5% 22, 6.5W, ±5% 150, 6.5W, ±5%	586054-11 27-590-29 586054-13 586054-17 586054-19 586054-27 586054-29 586054-39	RCL, T-5 WL, 12.5X RCL, T-5 RCL, T-5 RCL, T-5 RCL, T-5 RCL, T-5 RCL, T-5 RCL, T-5
R4	x								0.68, 6.5W	586054-11	RCL, T-5
R5	x								Not used 5, 50W 20, 50W 75, 50W 150, 50W 250, 50W 1.0K, 50W 4.0K, 50W 7.5K, 50W	27-807 27-1041 27-842 27-875 27-813 27-863 27-1018 27-737	WL, 70/50T-5 WL, 50F20WL WL, 70/50F7.5 WL, 50F150 WL, 70/50F250 WL, 70/50F1000 WL, 50F4000 WL, 25F7500
R6	x	x	x	x	x	x	x	x	Not used 7.5K, 25W	27-737	WL, 25F7500
R7	x								50A Shunt	588151-1	RAM, 63L53-50A-50MV
R8	x	x	x	x	x	x	x	x	Not used 12K, 2W, VAR	29-590	CL, 43
R9	x	x	x	x	x	x	x	x	80, 2W, VAR	29-593	CL, 43
R10	x								0.01 0.016 0.031 0.045 0.067 0.135 0.275 0.540	588282-1 588288-1 588289-1 588287-1 588286-1 588285-1 588284-1 588283-1	SR SR SR SR SR SR SR SR
R11	x	x	x	x	x	x	x	x	650, 2W, VAR	589336-1	CL, 43
R12	x	x	x	x	x	x	x	x	80, 2W, VAR	29-593	CL, 43
R13	x	x	x	x					Not used 0.33, 12.5W(W/W) 1.5, 12.5W (W/W) 6.8, 12.5W (W/W)	27-590-13 27-590-29 27-590-45	WL, 12.5X WL, 12.5X WL, 12.5X

Table 6-2
 Replaceable Parts List
 DCR-B Main Assembly, 500-Watt Series

CIRCUIT SYMBOL	DCR-B MODEL								DESCRIPTION	SORENSEN PART NUMBER	MANUFACTURER, TYPE
	10-40	20-25	40-13	60-9	80-6	150-3	300-1.5	600-.75			
S1	x	x	x	x	x	x	x	x	Power Switch	45-169	CH, 250V, 10A
T1	x	x	x	x	x	x	x	x	<u>Transformers</u> R/I R/I R/I R/I R/I R/I R/I	588281-1 588281-2 588281-3 588281-4 588281-5 588281-6 588281-7	SR SR SR SR SR SR SR
T2	x	x	x	x	x	x	x	x	Control	588240-1	SR
									<u>Miscellaneous</u> RF Choke and Heatsink Assembly	588179-1	SR
	x	x	x	x	x	x	x	x	Control Knobs (4)	42-274	SR
									<u>Schematic Diagrams, Main Assy.</u>	<u>PCB Assy. No.</u>	
									10-40B D588321	588176-1	
									20-25B D588322	588176-2	
									40-13B D588323	588176-3	
									60-9B D588328	588176-4	
									80-6B D588329	588176-5	
									150-3B D588324	588176-6	
									300-1.5B D588325	588176-7	
									600-.75B D588326	588176-8	
J2	x	x	x	x	x	x	x	x	<u>Chassis Connectors</u> PCB Interface	586287-5	Molex, 09-50
J3	x	x	x	x	x	x	x	x	PCB Interface	586287-5	Molex, 09-50
J4	x	x	x	x	x	x	x	x	PCB Interface	586287-5	Molex, 09-50
J5	x	x	x	x	x	x	x	x	OVP (3 Ckt.)	587008-2	Molex, 09-57-10B5
TB1	x	x	x	x	x	x	x	x	Pin Connectors for P2/P3/P4, 2 required Output terminal board	587008-11 247-7204P3	Molex, 09-57-1125 Kulka, 60z
CR7	x	x	x	x	x	x	x	x	*For 208-/220-/230-volt inputs: (options M1/M2/M3/ respectively)		
F1	x	x	x	x	x	x	x	x	T6411M (TRIAC)	588080-6	RCA
F2	x	x	x	x	x	x	x	x	0.1A, 250V (SB)	226-7177P32	BUS, MDL
									8A, 250V, (3AB)	42-1808	BUS, ABC-8

Table 6-2
 Replaceable Parts List
 DCR-B Main Assembly, 500-Watt Series (cont'd)

CIRCUIT SYMBOL	DCR-B MODEL								DESCRIPTION	SORENSEN PART NUMBER	MANUFACTURER, TYPE
	10-40	20-25	40-13	60-9	80-6	150-3	300-1.5	600-.75			
									Miscellaneous (cont'd)		
									Cover Top & Bottom (2 Required)	586868-1	SR
									Cover, Access	586870-1	SR
									Cover, Rear	586869-1	SR
									Case, Side, (2 Required)	586867-1	SR
									Handle, (2 Required)	30-784	SR
									Foot, Rubber (4 Required)	91-214	SR
	x								Panel, Front	586863-1	SR
		x								586863-2	SR
			x							586863-3	SR
				x						586863-4	SR
					x					586863-5	SR
						x				586863-6	SR
							x			586863-7	SR
								x		586863-8	SR

7. OVERVOLTAGE ACCESSORY (M5 OPTION)

7.1 GENERAL

The Sorensen DCR-B overvoltage protectors (OVP), available as optional equipment, are designed specifically to protect voltage-sensitive loads such as integrated and discrete solid-state circuitry from damage due to overvoltage conditions.

The OVP's comprise a fast-response silicon-controlled rectifier (SCR) crowbar, triggered by a signal from a solid-state voltage comparator that is continually monitoring the power-supply output voltage. If this output level exceeds the preset trip level of the OVP module, a firing signal is applied to the SCR crowbar, and the output voltage is reduced to 2.5 volts or less within 50 microseconds, protecting the load from possible damage.

Figure 7-1 defines the physical characteristics of the module, and Figure 7-2 details the component layout of the printed-circuit board (PCB), including a schematic diagram of the system. Tables 7-1/-2/-3 list replaceable OVP parts.

7.2 INSTALLATION

The OVP's are designed to be attached to fixed, threaded studs at the rear of the DCR-B supply, using the hardware supplied. The installation is as follows:

1. Remove access cover, rear panel, and top cover.
2. Place spacers on the three PCB mounting studs (terminal strip side of the rear chassis cutout).
3. Place fiber washers, and then shoulder washers on the two remaining mounting studs.
4. Mount the OVP so that J1 on the PCB aligns with the 3-pin connector (J5) on the rear chassis.
5. Run OVP leads through the heatsink cutout, and along the chassis edge to the output terminals.
6. Secure the OVP:
 - A. PCB: use a flat washer and locking nut on each of the three mounting studs.

- B. Heatsink: use a shoulder washer, flat washer and locking nut on the two remaining mounting studs.

HEATSINK MUST BE INSULATED FROM CHASSIS.

7. Connect the gray wire to the positive output terminal, and the white wire to the negative output terminal.
8. Turn the OVP potentiometer (R3, Figure 7-1) fully clockwise.
9. Replace top cover, rear panel and access cover.

7.3 OVP ADJUSTMENT

After installation, the OVP operating point is set as follows:

1. With OVP potentiometer R3 (accessible through aperture in rear panel) fully clockwise, set unit power to ON, and adjust front-panel control to the desired trip point as indicated on the unit voltmeter.
2. Adjust R3 slowly counterclockwise until the OVP trips. Leave R3 in this position.
3. Set unit power to OFF, and turn front-panel voltage control counterclockwise away from the trip point.
4. Apply unit power and adjust the supply output voltage to the desired operating level.

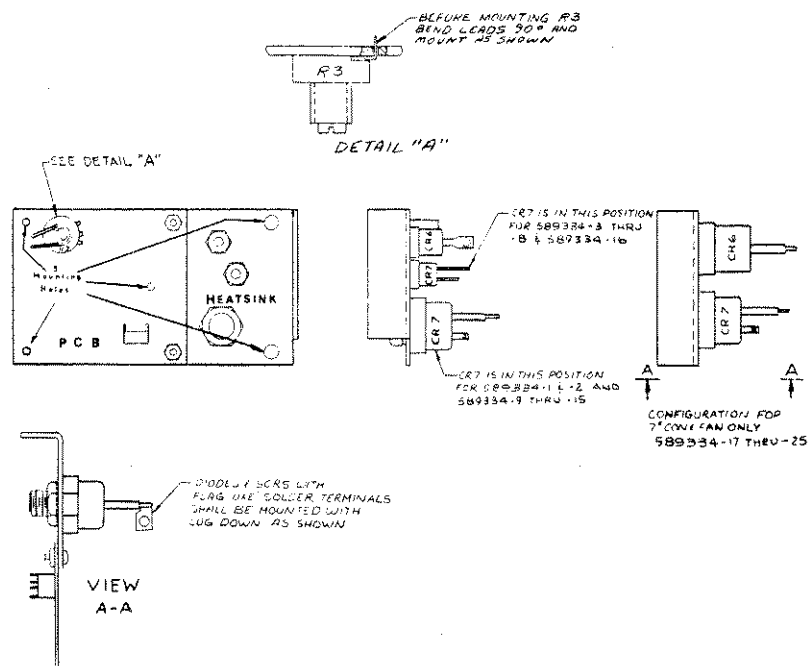
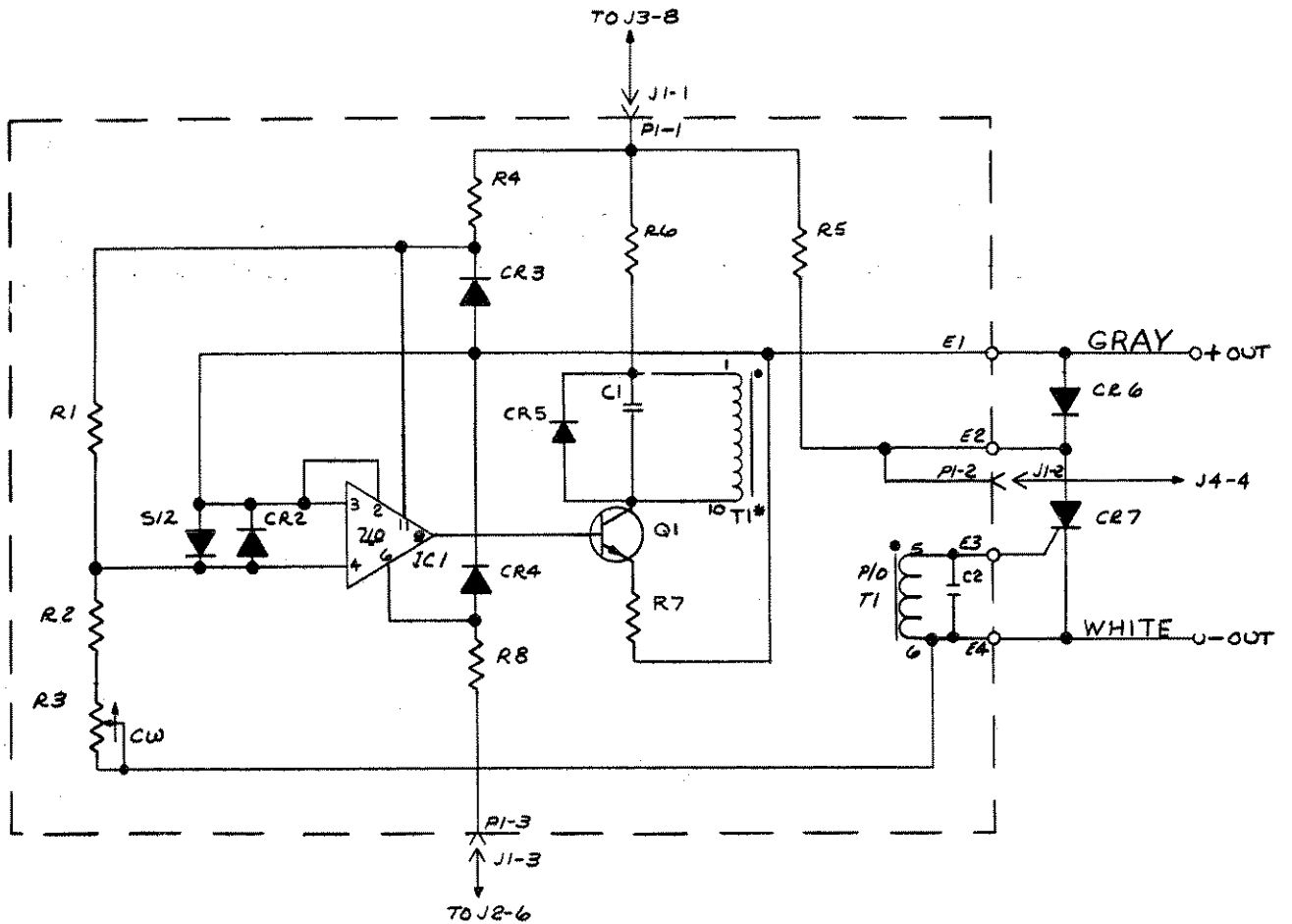
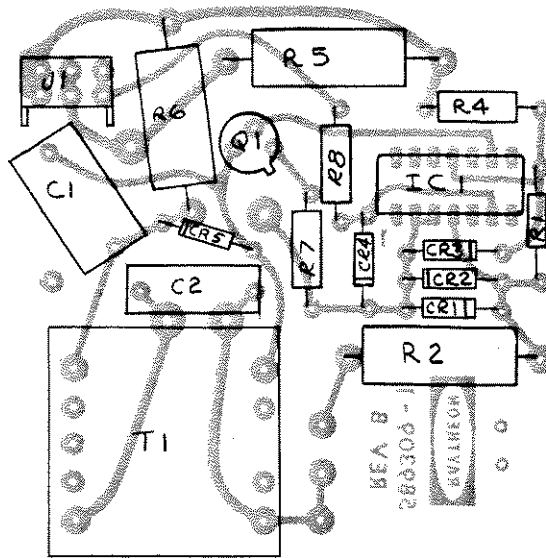

Figure 7-1
OVP Assembly
Component Layout



* PIN 8 CUT FOR KEYING

C 589335

Figure 7-2
OVP PCB Schematic and Assembly Drawings

TABLE
REPLACEABLE PARTS LIST
DCR-B OVP

CIRCUIT SYMBOL									DESCRIPTION	SORENSEN PART NUMBER	MANUFACTURER, TYPE
	10V	20V	40V	60V	80V	150V	300V	600V			
C1	X	X	X	X	X	X	X	X	CAPACITORS	24-2015-13	SE, MMK
C2	X	X	X	X	X	X	X	X	0.1uF, 250V	24-2037-15	SE, MMK
CR1	X	X	X	X	X	X	X	X	DIODES	587565-2	SEM
CR2	X	X	X	X	X	X	X	X	S12	587565-2	SEM
CR3	X	X	X	X	X	X	X	X	1N5242B	588101-15	MA
CR4	X	X	X	X	X	X	X	X	1N753/1N5234B	588101-9	MA
CR5	X	X	X	X	X	X	X	X	S12	587565-2	SEM
CR6	X	X	X	X	X	X	X	X	1N4587	587571-5	WH
CR7	X	X	X						SCR(2N1792)	589339-2	GE,C52F
				X	X				SCR(2N1793)	589339-3	GE,C52A
					X	X			SCR	589339-9	GE,C52E
							X		SCR	589339-11	GE,C52S
IC1	X	X	X	X	X	X	X	X	SN72710CN	386-7277P4	TI
Q1	X	X	X	X	X	X	X	X	2N2222A	386-7249P57	RCA
R1	X	X	X	X	X	X	X	X	RESISTORS(OHMS)	586055-125	EL,MF4
R2	X	X	X	X	X	X	X	X	11.5K,1/8W,+1%	280-1147P86	AB,HB
R3	X								15K,2W,VARIABLE	589337-17	BNS,3859A-166
		X							25K,2W,VARIABLE	589337-19	BNS,3859A-166
			X						50K,2W,VARIABLE	589337-21	BNS,3859A-166
				X					75K,2W,VARIABLE	589337-22	BNS,3859A-166
					X				100K,2W,VARIABLE	589337-23	BNS,3859A-166
						X			200K,2W,VARIABLE	589337-25	BNS,3859A-166
							X		300K,2W,VARIABLE	589337-27	BNS,3859A-166
								X	750K,2W,VARIABLE	589337-29	BNS,3859A-166
R4	X	X	X	X	X	X	X	X	1.2K,1/2W,+10%	280-1145P77	AB,EB
R5	X	X	X	X	X	X	X	X	330,6.5W,+5%	586054-43	RCL,T-5
R6	X	X	X	X	X	X	X	X	330,2W,+10%	280-1147P56	AB,HB
R7	X	X	X	X	X	X	X	X	22,1/2W,+10%	280-1145P14	AB,EB
R8	X	X	X	X	X	X	X	X	3K,1/2W,+5%	280-1145P90	AB,EB
T1	X	X	X	X	X	X	X	X	PULSE TRANSFORMER	589333-1	SR
J1	X	X	X	X	X	X	X	X	PCB CONNECTOR	588893-1	MOLEX
									MISCELLANEOUS		
	X								OVP ASSEMBLY		
		X							10V	589334-17	SR
			X						20V	589334-18	SR
				X					40V	589334-19	SR
					X				60V	589334-20/21	SR
						X			80V	589334-22	SR
							X		150V	589334-23	SR
								X	300V	589334-24	SR
									600V	589334-25	SR

TABLE
REPLACEABLE PARTS LIST (Cont'd)
DCR-B OVP

CIRCUIT SYMBOL									DESCRIPTION	SORENSEN PART NUMBER	MANUFACTURER, TYPE
	10V	20V	40V	80V	80V	150V	300V	600V			
	X	X	X	X	X	X	X	X	MISCELLANEOUS (Cont'd)		
									OVP P.C.B. ASSEMBLY		
									10V	589308-1	SR
									20V	589308-2	SR
									40V	589308-3	SR
									60V	589308-4	SR
									80V	589308-5	SR
									150V	589308-6	SR
									300V	589308-7	SR
									600V	589308-8	SR

Table 7-2
OVP-CROWBAR RECTIFIER CR7 (500/1000W SERIES)

Unit Voltage	Description	Sorensen Part No.	Mfr./Type
10, 20V	75V PIV	26-1161-2	GE C45F
40, 60, 80V (500W)	150V PIV	26-178-3	GE 2N683C
40, 60, 80V (1000W)	150V PIV	26-1161-3	GE C45A
150V (1000W)	300V PIV	26-1161-5	GE C45B
150, 300V (500W)	500V PIV	26-178-6	GE 2N688C
300V (1000W)	500V PIV	26-1161-8	GE C45D
600V	1000V PIV	26-1159-6	GE C137P

Table 7-3
OVP-CROWBAR RECTIFIER CR7 (1800/2700W SERIES)

Unit Voltage	Description	Sorensen Part No.	Mfr./Type
10, 20, 40V	SCR (2N1792)	589339-2	GE C52F
60, 80V	SCR (2N1793)	589339-3	GE C52A
150, 300V	SCR	589339-9	GE C52E
600V	SCR	589339-11	GE C52S

SERVICE NOTES

SERVICE NOTES

FIELD SERVICE REPRESENTATIVES

WESTERN AREA

Ball Aerospace Systems
Boulder Industrial Park
Boulder, Colorado 80302
Tel: 303/441-4786

General Electric Instrumentation Service
3840 W. Clarendon Street
Phoenix, Arizona 85017
Tel: 602/278-8515

General Electric Instrumentation Service
4690 South Park Avenue
Tucson, Arizona 85714
Tel: 602/294-3139

J. D. & Associates
1012 Morse Avenue, Suite 6
Sunnyvale, California 94086
Tel: 408/734-5529

Staus Engineering
Unit 26, 1900 Tyler Avenue
South El Monte, California 91733
Tel: 213/442-3634

Missouri Research Labs Inc.
630 Haines Avenue N. W.
Albuquerque, New Mexico 87102
Tel: 505/243-6772

Certified Test Equipment Sales Inc.
601 Easy Street
Garland, Texas 75042
Tel: 214/494-3446

EASTERN AREA

Ampower Electronic Instrument Co., Inc.
500 Union Boulevard
Totowa, New Jersey 07512
Tel: 201/790-6750

Ampower Electronic Instrument Co., Inc.
59 Central Avenue
Unit 3
Farmingdale, New York 11735
Tel: 516/752-1078

Ampower Electronic Instrument Co., Inc.
1161 Brighton-Henrietta Town Line Road
Rochester, New York 14623
Tel: 716/424-1220

Applied Metrology Inc.
10067 N. 2nd Street
Laurel, Maryland 20810
Tel: 301/953-1010

Comtel Standards Laboratory
21186 Bridge Street
P. O. Box 5034
Southfield, Michigan 48037
Tel: 313/358-2500

Comtel Instrument Company
5827 Mayfield Road
Cleveland, Ohio 45429
Tel: 216/442-8080

Valley Instrument Company
491 Clover Mill Road
Exton, Pennsylvania 19341
Tel: 215/363-2650

NEW ENGLAND AREA

Sorensen Company
676 Island Pond Road
Manchester, N. H. 03103
Tel: 603/668-4500

FOREIGN AREA

CANADA

Associated Test Equipment Ltd.
3530 Pharmacy Avenue
Scarborough, Ontario
Canada M1W 2S7
Tel: 416/497-2208

ENGLAND

Best Products Ltd.
Electronic Division
Ranelagh House
Felixstowe, Suffolk
England IP11 7HB
Tel: Felixstowe (039-42) 3154

FRANCE

NAVALEC
Compagnie de Diffusion de
Materiel Electronique
7, Rue Lavoisier
F-75008 Paris

SWITZERLAND

Sorensen AG
Halbartenstrasse 54
CH 5430 Wettingen
Switzerland
Tel: 056 2651 16

SORENSEN
POWER SUPPLIES

10/78