

5 to 20 kW Three Phase Input Lab & Industrial Power Supplies DCR-A Series

DCR-A Series supplies 5 to 20 kW power levels in 11 models in ranges from 0-20 Vdc to 0-600 Vdc. SCR controlled regulator produces high efficiency and fully adjustable output power.

- 11 models in five voltage ranges, from 0-20 Vdc to 0-600 Vdc, with power levels from 5 to 20 kW
- 208 Vac three phase input standard on 5 kW models. 460 Vac, three phase input standard on all others
- 50/60 Hz operation
- Optional input voltages available for 208/230/390/415 Vac three phase operation
- Remote voltage or resistance programming in voltage and current modes
- Adjustable current limiting (overload/short circuit protection) with automatic recovery
- Excellent voltage and current regulation with automatic crossover
- 0.2% line & load regulation (typical)
- 160-2000 mV rms ripple (model dependent)
- 40 ms transient response—50% changes (typical)
- Option M5: OVP except 20 kW models
- Options M2, M3, M6, M8: Input voltage modifications (see page 57)
- 5-year warranty

DCR-A Series is a Proven Design with Excellent Performance & Reliability. Newer Products with Similar Performance, Capabilities and Lower Cost may be Found in the DCR-T Series on Page 49.

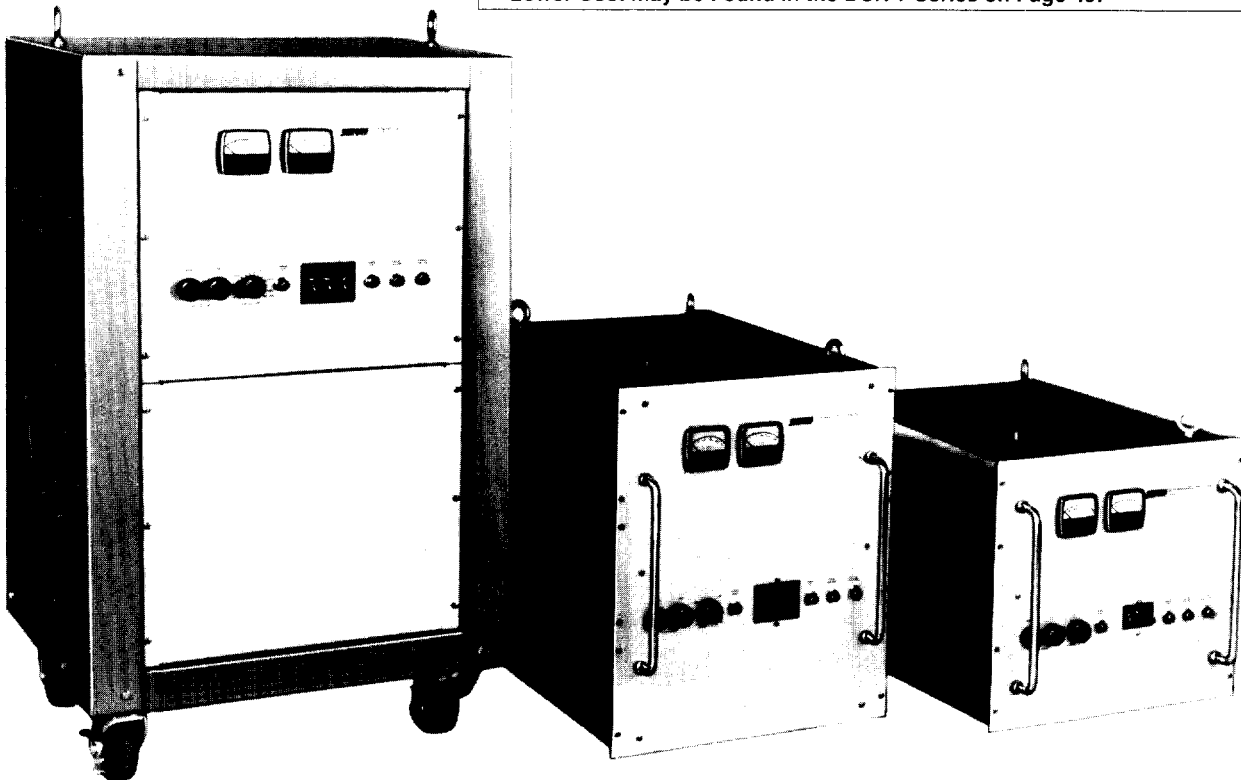

Toll Free: 1-800-525-2024

DC OUTPUT

CONSTANT VOLTAGE MODE

Voltage Regulation:

Line and load combined:
0-20 Vdc to 0-40 Vdc models
0.2% or 30 mV, whichever is greater.

0-150 Vdc to 0-600 Vdc models

Line and load combined:
0.2% or 240 mV, whichever is greater.

Temperature Coefficient:

0.04%/°C of E_o max.

Resistive Programming:

See model specification chart.

Voltage Programming:

Consult local sales office or factory.

Stability:

0.1% E_o max for 8 hours after 30 minute warm-up.

Remote Sensing:

3 V maximum drop per load lead but not to exceed 10% of E_o max.

Transient Response:

40 ms (typical) to return to $\pm 1\%$ band for a step load change. 50% to 100% or 100% to 50% of full load. (20 V models $\pm 2\%$ band.)

CONSTANT CURRENT MODE

Current Regulation:

0.4% I_o max. line and load combined.

Temperature Coefficient:

0.2%/°C of I_o max.

Current Programming:

See model specification chart.

Stability:

0.5% of I_o maximum for 8 hours after 30 minute warm-up.

INPUT

Voltage:

187-229 Vac three phase for 5 kW models. 414-506 Vac three phase for 10 and 20 kW models.

Voltage Options:

Optional inputs available. See page 57.

Model	Output Power				Constant Voltage Mode					Temp. Coeff., Voltage mV/°C (Typ.)	Voltage Drift, % E_o Max. ³ (Typ.)	Programming Constants Voltage Mode		Over-Voltage Protection
	Voltage (Vdc)	Current (A dc)			Regulation Line & Load ¹ 0.2% or _ mV	Ripple (PAR) ²		Resolution mV (Typ.)	Transient Response Time ms (Typ.) ²			Ohms/V	V/V	
		40°C	50°C	70°C		mV rms	mV p-p							
DCR 20-250A	0-20	275	250	165	16	160	480	10	40	8	0.1	160	Note 11	VP18
DCR 20-500A	0-20	550	500	330	16	160	480	10	40	8	0.1	160	Note 11	VP24
DCR 20-1000A	0-20	1100	1000	660	16	160	480	10	40	8	0.1	160	Note 11	—
DCR 40-125A	0-40	138	125	82.5	30	160	480	20	40	16	0.1	80	Note 11	VP19
DCR 40-250A	0-40	275	250	165	30	160	480	20	40	16	0.1	80	Note 11	VP19
DCR 40-500A	0-40	550	500	330	30	160	480	20	40	16	0.1	80	Note 11	—
DCR 150-35A	0-150	38.5	35	23	60	500	1500	75	40	60	0.1	20	Note 11	VP20
DCR 150-70A	0-150	77	70	47	60	500	1500	75	40	60	0.1	20	Note 11	VP20
DCR 300-18A	0-300	19.8	18	12	120	1000	3000	150	40	120	0.1	10	Note 11	VP21
DCR 300-35A	0-300	38.5	35	23	120	1000	3000	150	40	120	0.1	10	Note 11	VP21
DCR 600-18A	0-600	19.8	18	12	240	2000	6000	300	40	240	0.1	5	Note 11	VP22

NOTES: 1. With load change (NL to FL or FL to NL) and line voltage change ($\pm 10\%$) combined, whichever is greater. 2. To return to $\pm 1\%$ band (20 V models $\pm 2\%$ band) for a step load change of half load to full load or full load to half load. 3. For 8 hours (after 30 min. warmup) with constant line, load and ambient temperature. 4. With 0 to 95% load change and $\pm 10\%$ line voltage change combined. 5. At full compliance voltage. 6. See page 57 for auxiliary chassis and optional input voltages. See page 57 for alternate voltage inputs (with voltage derating, if applicable). 7. Below 60 Hz, ripple and transient response characteristics will deteriorate by a factor of $(60/f)^2$, where f is the input frequency. 8. Also derated DC output voltage to 86-7% of maximum at 50°C. 9. 60/54 A drawn with 208/230 Vac input; 27 A at 460 Vac. 10. See page after next for alternate input voltages. 11. Contact factory.

DCR-A Series Specifications

Frequency:

57-63 Hz all models.
49-63 Hz for 5 kW models only.
49-63 Hz for 380/415 V operation only on 10 kW and 20 kW models.

OPERATING DATA

Efficiency:

66-82% depending on model.

Series Operation:

200 Vdc maximum (150 and 300 V models, two in series).

Parallel Operation:

Direct paralleling of any number of units.

Overvoltage Protection:

Optional adjustable crowbar protection available on all models except DCR 20-1000A and DCR 40-500A. Add suffix M5 to model number.

Ambient Operating

Temperature Range:

0 to + 70°C

Storage Temperature Range:

- 40°C to +85°C.

Cooling:

Forced air.

Casters:

Standard on models DCR 20-1000A and DCR 40-500A. Available as option on all other models. Specify Kit CH.

Step Down Input Transformer

380/415/460 Vac three phase to 208/230 Vac three phase @ 8 kW for models DCR 20-250A, DCR 40-125A, DCR 150-35A, DCR 300-18A. Specify ST 101.

Digital Programmer:

Available for all models in DCR-A series. IEEE-488 interface to GPIB Bus. See page 61.

OPTIONS

M5: OVP except on 20 kW models
M1, M3, M6, M8: input voltage modification; see page 57.

Model	Constant Current Mode			Temp. Coeff., Current mA/°C (Typ.)	Current Drift, % Io (Max) (Typ.) ²	Programming Constants Current Mode		Standard Input Power (3 phase) ⁶			Power Factor (Typ.)	Efficiency % (Typ.)	Case Size
	Regulation mA ⁴	Ripple (PAR) mV rms ⁵	Resolution mA (Typ.)			Ohms/A	V/A	Voltage Vac	Current ⁷ Aac (Max.)	Freq Hz ⁷			
DCR 20-250A	1000	2000	1250	500	0.5	0.6	Note 11	187-229	37	50-63	.57	66	I
DCR 20-500A	2000	4000	2500	1000	0.5	0.3	Note 11	414-506	27	47-63	.63	70	II
DCR 20-1000A	4000	8000	5000	2000	0.5	0.15	Note 11	414-506	80	57-63 ¹⁰	.63	74	III
DCR 40-125A	500	563	625	250	0.5	1.2	Note 11	187-229	25	50-63	.60	72	I
DCR 40-250A	1000	1125	1250	500	0.5	0.6	Note 11	414-506	60, 27 ⁸	57-63 ¹⁰	.67	75	II
DCR 40-500A	2000	2250	2500	1000	0.5	0.3	Note 11	414-506	60	50-63	.59	79	III
DCR 150-35A	140	140	350	70	0.5	4.3	Note 11	187-229	35	60-63	.64	77	I
DCR 150-70A	280	280	350	140	0.5	2.2	Note 11	414-506	60, 27 ⁹	57-63 ¹⁰	.69	81	II
DCR 300-18A	72	72	175	36	0.5	8.3	Note 11	187-229	35	50-63	.69	78	I
DCR 300-35A	140	140	175	70	0.5	4.3	Note 11	414-506	60, 27 ⁹	57-63 ¹⁰	.68	82	II
DCR 600-18A	72	72	90	36	0.5	8.3	Note 11	414-506	60, 27 ⁹	57-63 ¹⁰	.69	81	II

CASE I

For rack mounting; rear mounting support RP9 (See Optional Equipment, page 60.)

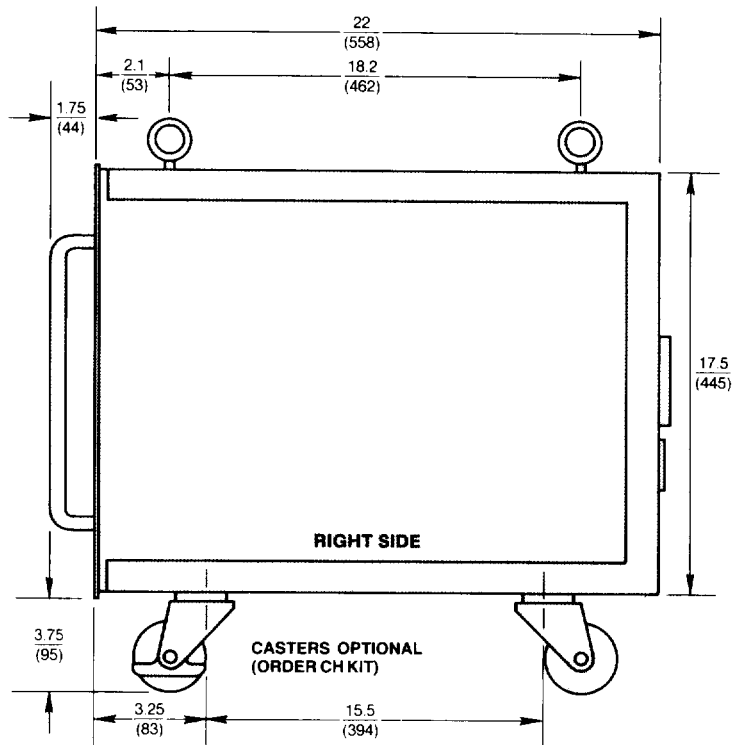
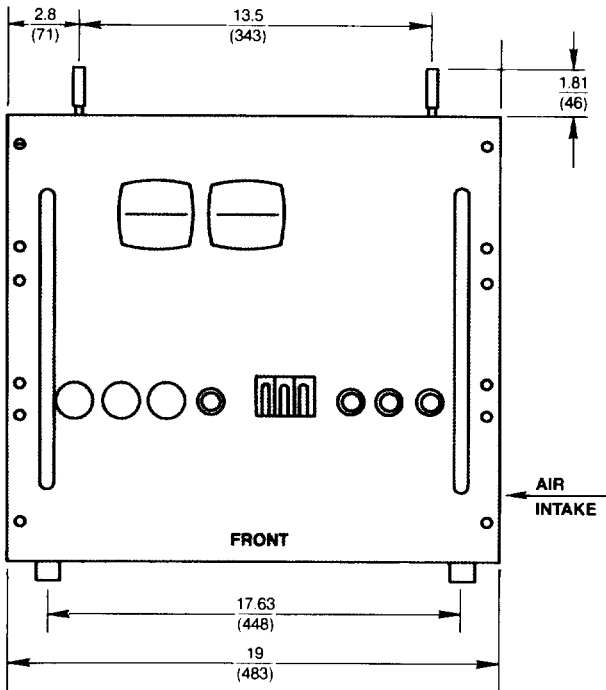
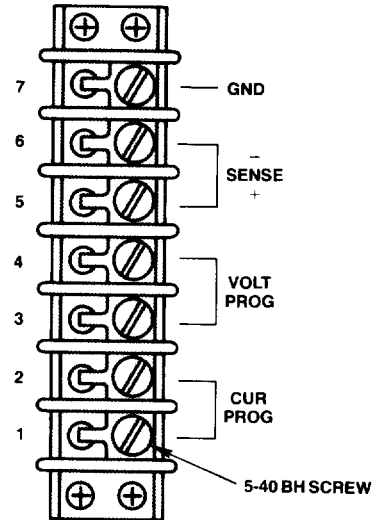
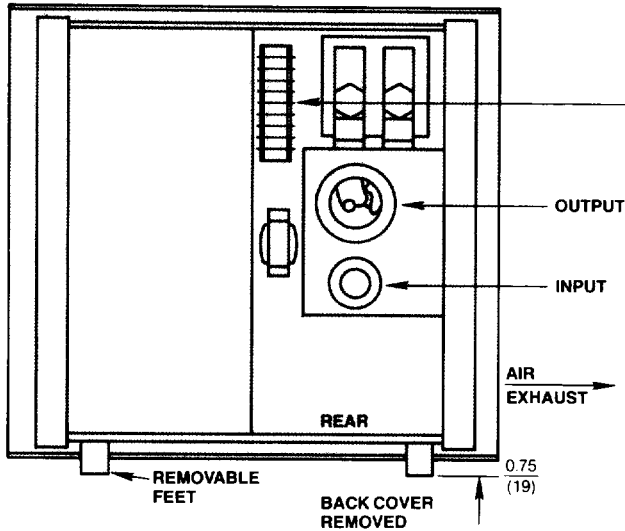

Input Terminals:	Model
4 Terminal barrier strip with 10-32BH Screws	DCR 150-35A DCR 300-18A
Cabinet side enclosures optional for all models (order CSE kit)	DCR 20-250A DCR 40-125A

Weight		Output Terminals
lb.	kg.	
309	140	Barrier Terminal
318	144	Blocks/10-32BH Screws
309	140	
315	143	Post lug terminals for 1/0 to 350 MCM

Note: All dimensions are in inches
(mm)

DCR-A Series Dimensional Drawings

ST 101 CHASSIS

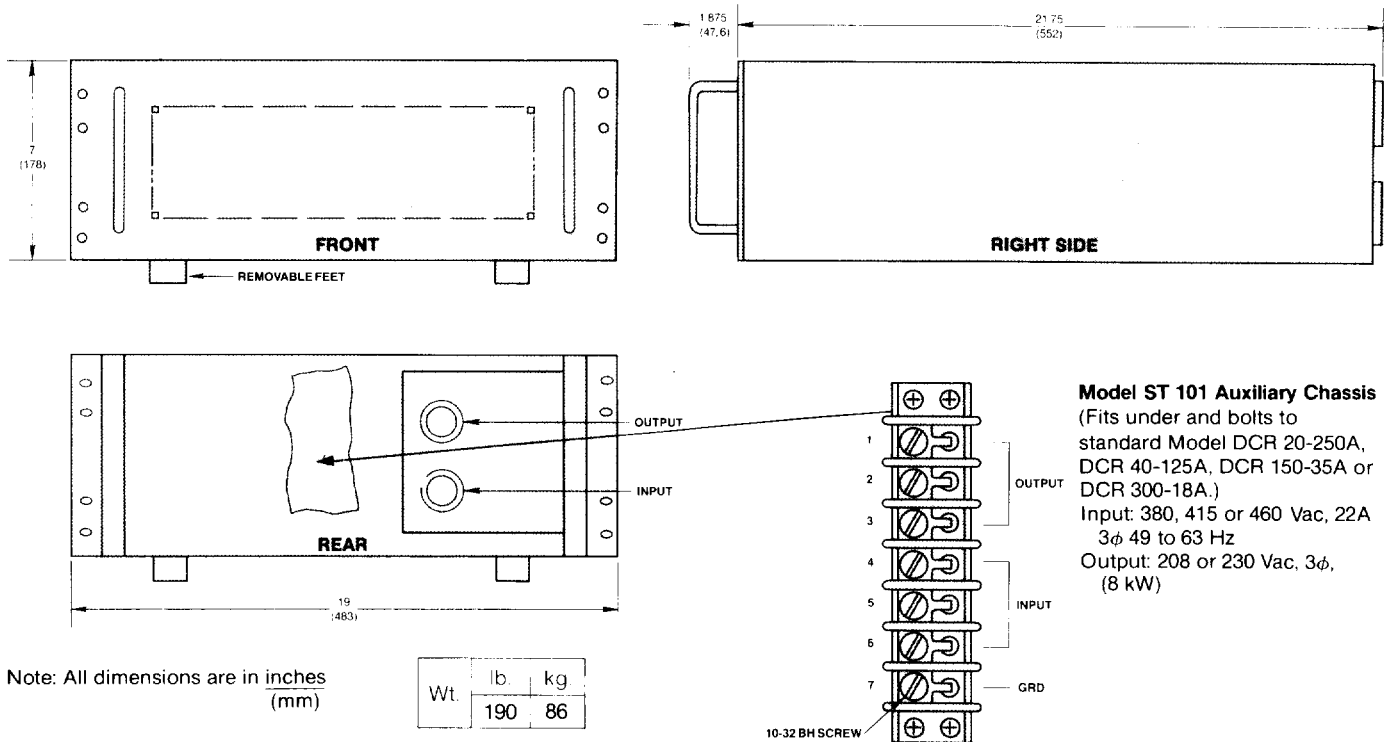

Factory Input Voltage Modifications

	Standards/Options ¹				
	187-229V	207-253V	342-418V (30)	390-440V	414-506V
DCR 20-250A	Standard	M3	N/A ²	N/A ²	N/A ²
DCR 20-500A	M1	M3	M6 ³	M8	Standard
DCR 20-1000A	N/A	N/A	M6 ⁴	M8 ⁴	Standard
DCR 40-125A	Standard	M3	N/A ²	N/A ²	N/A ²
DCR 40-250A	M1	M3	M6 ³	M8	Standard
DCR 40-500A	N/A	N/A	M6 ⁴	M8 ⁵	Standard
DCR 150-35A	Standard	M3	N/A ²	N/A ²	N/A ²
DCR 150-70A	M1	M3	M6 ³	M8	Standard
DCR 300-18A	Standard	M3	N/A ²	N/A ²	N/A ²
DCR 300-35A	M1	M3	M6 ³	M8	Standard
DCR 600-18A	M1	M3	M6 ³	M8	Standard

NOTES: 1. To specify, add option suffix to model number. Example: DCR 40-250A M8. 2. Modification is not available; specify optional stepdown transformer (see Accessory ST-101). 3. Derate output voltage range by 10%. 4. Derate to 75% Eo max. 5. Derate to 92% max.

Field Input Voltage Modifications

Alternatively, where applicable, customer may perform field modification without voiding warranty. (See instruction manual for simple transformer tap changes.)

For rack mounting; consult factory.

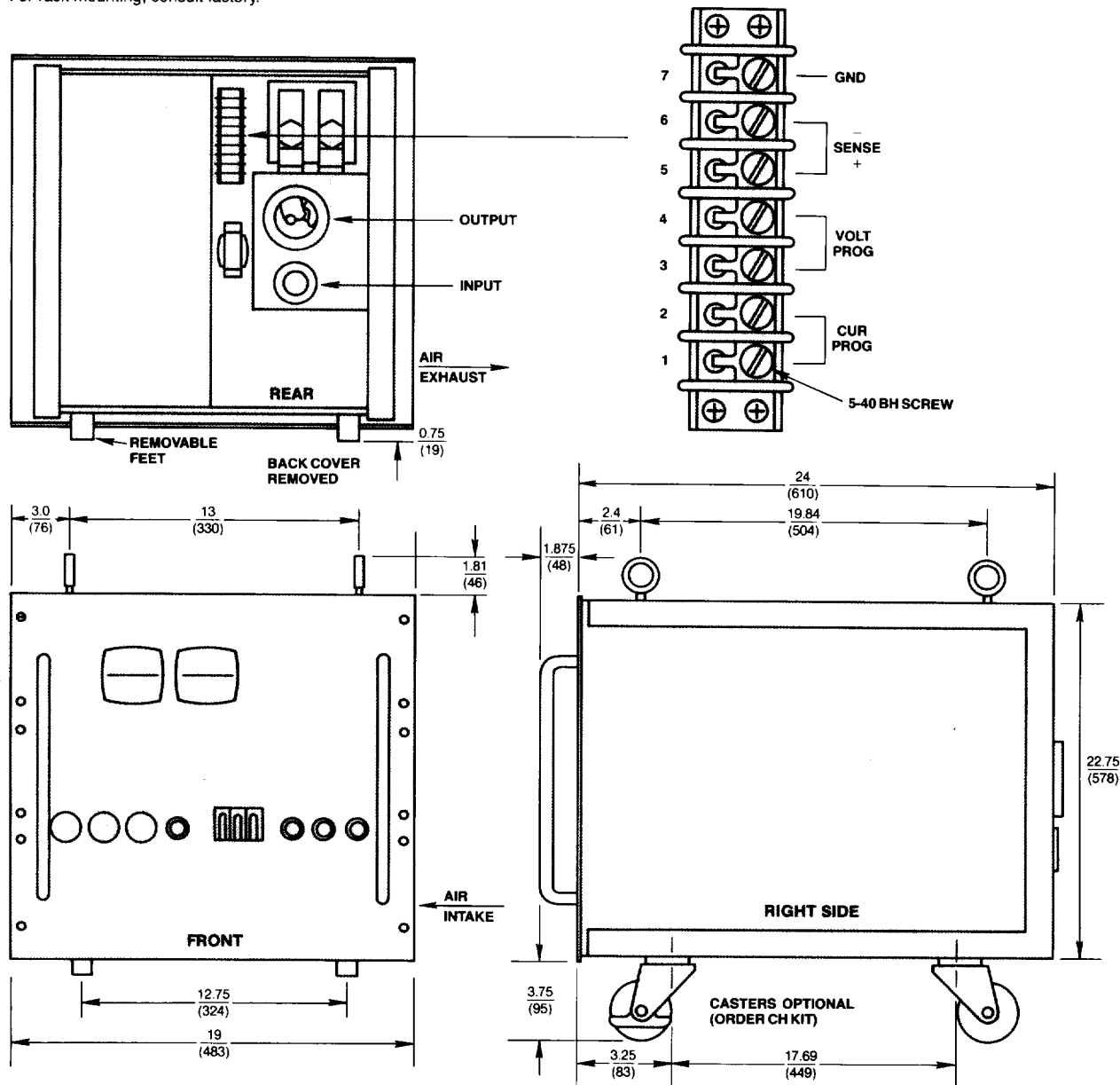

Input Terminals	Model	Weight		Output Terminals
		lb.	kg.	
4 terminal barrier strip with 12-32BH Screws	DCR 300-35A	481	218	Barrier Terminal Blocks/10-32BH Screws post lug terminals for 700MCM to 1000 MCM post lug terminals for 1/0 to 350 MCM
	DCR 600-18A	481	218	
	DCR 20-500A	481	218	
	DCR 40-250A	481	218	
Cabinet side enclosures optional for all models (order CSE kit)	DCR 150-70A	481	218	post lug terminals for #4 strd. to #1 strd.

Note: All dimensions are in inches (mm)

DCR-A Series Dimensional Drawings

CASE III

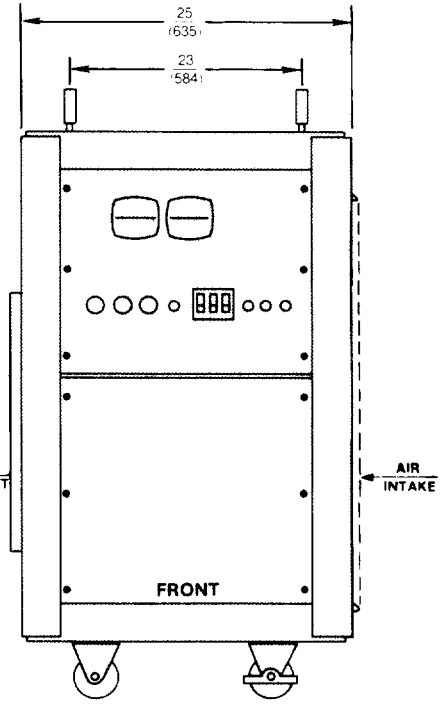
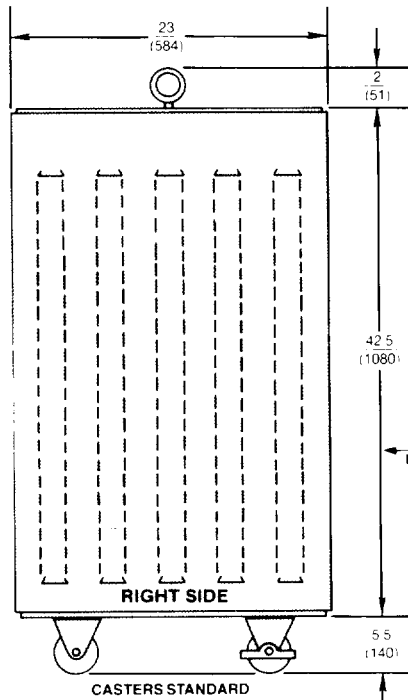
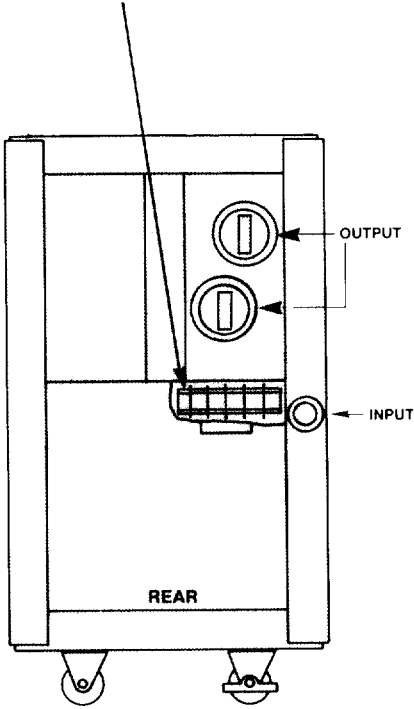
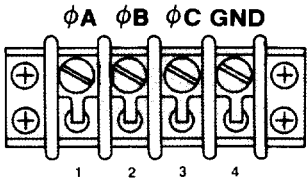

Input Terminals

4 terminals barrier strip (DCR 40-500A - 12-32BH Screws, DCR 20-1000A - 1/4-28BH Screws)

Model

DCR 20-1000A

Weight

lb.

973

kg.

438

Output Terminals

1/4" Thick x 3" Wide Bus-Bar, with (4) 9/16" Dia. Hole on 1-3/4" x 1-3/4" centers.

DCR 40-500A

973

438

1/4" Thick x 3" Wide Bus-Bar, with (4) 9/16" Dia. Hole on 1-3/4" x 1-3/4" centers.

Note: All dimensions are in inches (mm)

DCR-A Series fully IEEE 488 Programmable

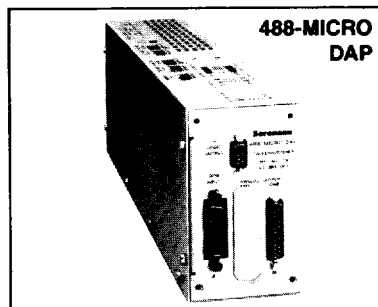
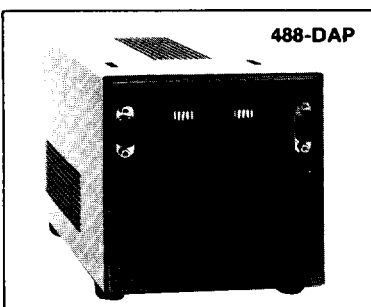

DCR-A Series is IEEE 488 programmable (and M.A.T.E. qualifiable) with either single or dual channel programmers; see page 61.

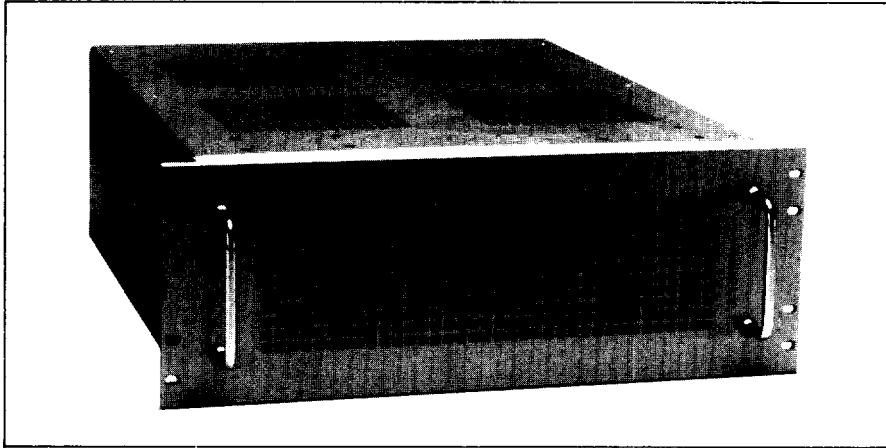

DCR-A auxiliary three phase, stepdown input transformer. (380/415/460 Vac to 208/230 Vac @ 8 kW). ST 101 (see drawing on page 57.)

Optional Input Voltage Modifications

Option	Description
M1	187-229 Vac, 1 phase, 57-63 Hz, 100% Eo max.
M3	207-253 Vac, 1 phase, 57-63 Hz, 100% Eo max.
M6	342-418 Vac, 3 phase, 47-63 Hz, 90% Eo max.
M8	390-440 Vac, 1 phase, 47-63 Hz, 100% Eo max.

NOTE: 414-506 Vac input is possible; see Factory Input Voltage Modifications table.