

Sorensen
XFR 1200 Watt Series
Programmable DC
Power Supply

Operation Manual

XFR 6-200
XFR 7.5-140
XFR 12-100
XFR 20-60
XFR 35-35
XFR 40-30
XFR 60-20
XFR 100-12
XFR 150-8
XFR 300-4
XFR 600-2

About AMETEK

AMETEK Programmable Power, Inc., a Division of AMETEK, Inc., is a global leader in the design and manufacture of precision, programmable power supplies for R&D, test and measurement, process control, power bus simulation and power conditioning applications across diverse industrial segments. From bench top supplies to rack-mounted industrial power subsystems, AMETEK Programmable Power is the proud manufacturer of Elgar, Sorensen, California Instruments and Power Ten brand power supplies.

AMETEK, Inc. is a leading global manufacturer of electronic instruments and electromechanical devices with annualized sales of \$2.5 billion. The Company has over 11,000 colleagues working at more than 80 manufacturing facilities and more than 80 sales and service centers in the United States and around the world.

Trademarks

AMETEK is a registered trademark of AMETEK, Inc. Sorensen is a trademark owned by AMETEK, Inc. Other trademarks, registered trademarks, and product names are the property of their respective owners and are used herein for identification purposes only.

Notice of Copyright

XFR 1200 Watt Series Programmable DC Power Supply Operation Manual © 2007 AMETEK Programmable Power, Inc. All rights reserved.

Exclusion for Documentation

UNLESS SPECIFICALLY AGREED TO IN WRITING, AMETEK PROGRAMMABLE POWER, INC. ("AMETEK"):

- (a) MAKES NO WARRANTY AS TO THE ACCURACY, SUFFICIENCY OR SUITABILITY OF ANY TECHNICAL OR OTHER INFORMATION PROVIDED IN ITS MANUALS OR OTHER DOCUMENTATION.
- (b) ASSUMES NO RESPONSIBILITY OR LIABILITY FOR LOSSES, DAMAGES, COSTS OR EXPENSES, WHETHER SPECIAL, DIRECT, INDIRECT, CONSEQUENTIAL OR INCIDENTAL, WHICH MIGHT ARISE OUT OF THE USE OF SUCH INFORMATION. THE USE OF ANY SUCH INFORMATION WILL BE ENTIRELY AT THE USER'S RISK, AND
- (c) REMINDS YOU THAT IF THIS MANUAL IS IN ANY LANGUAGE OTHER THAN ENGLISH, ALTHOUGH STEPS HAVE BEEN TAKEN TO MAINTAIN THE ACCURACY OF THE TRANSLATION, THE ACCURACY CANNOT BE GUARANTEED. APPROVED AMETEK CONTENT IS CONTAINED WITH THE ENGLISH LANGUAGE VERSION, WHICH IS POSTED AT WWW.PROGRAMMABLEPOWER.COM.

Date and Revision

February 2009 Revision C

Part Number

TM-F10P-C1XN



Contact Information

Telephone: 800 733 5427 (toll free in North America)
858 450 0085 (direct)
Fax: 858 458 0267
Email: sales@programmablepower.com
service@programmablepower.com
Web: www.programmablepower.com

This page intentionally left blank.

Important Safety Instructions

Before applying power to the system, verify that your product is configured properly for your particular application.

	Hazardous voltages may be present when covers are removed. Qualified personnel must use extreme caution when servicing this equipment. Circuit boards, test points, and output voltages also may be floating above (below) chassis ground.
	The equipment used contains ESD sensitive parts. When installing equipment, follow ESD Safety Procedures. Electrostatic discharges might cause damage to the equipment.

Only *qualified personnel* who deal with attendant hazards in power supplies, are allowed to perform installation and servicing.

Ensure that the AC power line ground is connected properly to the Power Rack input connector or chassis. Similarly, other power ground lines including those to application and maintenance equipment *must* be grounded properly for both personnel and equipment safety.

Always ensure that facility AC input power is de-energized prior to connecting or disconnecting any cable.

In normal operation, the operator does not have access to hazardous voltages within the chassis. However, depending on the user's application configuration, **HIGH VOLTAGES HAZARDOUS TO HUMAN SAFETY** may be normally generated on the output terminals. The customer/user must ensure that the output power lines are labeled properly as to the safety hazards and that any inadvertent contact with hazardous voltages is eliminated.

Guard against risks of electrical shock during open cover checks by not touching any portion of the electrical circuits. Even when power is off, capacitors may retain an electrical charge. Use safety glasses during open cover checks to avoid personal injury by any sudden component failure.

Neither AMETEK Programmable Power Inc., San Diego, California, USA, nor any of the subsidiary sales organizations can accept any responsibility for personnel, material or inconsequential injury, loss or damage that results from improper use of the equipment and accessories.

SAFETY SYMBOLS

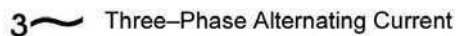
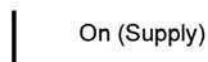
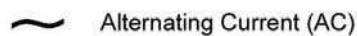
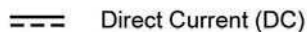
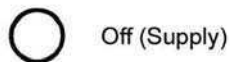
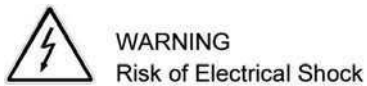

This page intentionally left blank.

Product Family: XFR 1200 Watt Series Programmable DC Power Supply

Warranty Period: Five Years

WARRANTY TERMS

AMETEK Programmable Power, Inc. ("AMETEK"), provides this written warranty covering the Product stated above, and if the Buyer discovers and notifies AMETEK in writing of any defect in material or workmanship within the applicable warranty period stated above, then AMETEK may, at its option: repair or replace the Product; or issue a credit note for the defective Product; or provide the Buyer with replacement parts for the Product.

The Buyer will, at its expense, return the defective Product or parts thereof to AMETEK in accordance with the return procedure specified below. AMETEK will, at its expense, deliver the repaired or replaced Product or parts to the Buyer. Any warranty of AMETEK will not apply if the Buyer is in default under the Purchase Order Agreement or where the Product or any part thereof:

- is damaged by misuse, accident, negligence or failure to maintain the same as specified or required by AMETEK;
- is damaged by modifications, alterations or attachments thereto which are not authorized by AMETEK;
- is installed or operated contrary to the instructions of AMETEK;
- is opened, modified or disassembled in any way without AMETEK's consent; or
- is used in combination with items, articles or materials not authorized by AMETEK.

The Buyer may not assert any claim that the Products are not in conformity with any warranty until the Buyer has made all payments to AMETEK provided for in the Purchase Order Agreement.

PRODUCT RETURN PROCEDURE

1. Request a Return Material Authorization (RMA) number from the repair facility (**must be done in the country in which it was purchased**):
 - **In the USA**, contact the AMETEK Repair Department prior to the return of the product to AMETEK for repair:
Telephone: 800-733-5427, ext. 2295 or ext. 2463 (toll free North America)
858-450-0085, ext. 2295 or ext. 2463 (direct)
 - **Outside the United States**, contact the nearest Authorized Service Center (ASC). A full listing can be found either through your local distributor or our website, www.programmablepower.com, by clicking Support and going to the Service Centers tab.
2. When requesting an RMA, have the following information ready:
 - Model number
 - Serial number
 - Description of the problem

NOTE: Unauthorized returns will not be accepted and will be returned at the shipper's expense.

NOTE: A returned product found upon inspection by AMETEK, to be in specification is subject to an evaluation fee and applicable freight charges.

This page intentionally left blank.

Contents

Important Safety Instructions	v
--	---

1 Introduction

Description	1-2
Features and Options	1-3
Front Panel Controls	1-3
Rear Panel Connectors and Switch	1-5
Rear Panel SW1 Switch	1-7
Resetting the Switches	1-8
Rear Panel J2 Connector	1-8
Making J2 Connections	1-10
Wiring	1-11

2 Installation

Introduction	2-2
Basic Setup Procedure	2-2
Inspection, Cleaning, and Packaging	2-3
Initial Inspection	2-3
Periodic Cleaning	2-3
Returning Power Supplies to the Manufacturer	2-3
Return Material Authorization Policy	2-3
Packaging for Shipping or Storage	2-5
Location, Mounting, and Ventilation	2-6
Rack Mounting	2-6
Ventilation	2-6
AC Input Power Connection	2-7
AC Input Connector and Voltage Selection	2-7
Auto Range Select	2-7
AC Fail LED	2-8
AC Input Cord	2-8
AC Input Wire Connection	2-9
Functional Tests	2-11
Equipment Required	2-11

Contents

Power-on Check	2-11
Voltage Mode Operation Check	2-12
Current Mode Operation Check	2-12
Front Panel Function Checks	2-13
Load Connection	2-14
Load Wiring	2-14
Insulation Rating	2-14
Current Carrying Capacity	2-14
Load Wiring Length for Operation with Sense Lines	2-15
Noise and Impedance Effects	2-16
Making Load Connections	2-16
6 V to 40 V Models	2-17
60 V to 600 V Models	2-19
Inductive Loads	2-20
Connecting Single Loads	2-21
Connecting Multiple Loads	2-22
Parallel Power Distribution	2-22
Radial Power Distribution Method	2-22
Local and Remote Sensing	2-24
Sense Wiring	2-24
Local Sensing	2-25
Using Remote Sensing	2-26

3 Local Operation

Introduction	3-2
Standard Operation	3-3
Operating Modes and Automatic Crossover	3-3
Constant Voltage Mode Operation	3-4
Constant Current Mode Operation	3-4
Automatic Mode Crossover	3-4
Shipped Configuration	3-5
Setting Output Voltage and Current Limit	3-6
Using Over Voltage Protection (OVP)	3-7
Front Panel OVP Operation	3-7
Resetting the OVP Circuit	3-8
Using the Shutdown Function	3-9
STANDBY Switch	3-9

Controlling the Shutdown Function via the J2 Connector	3-9
Using Multiple Supplies	3-11
Configuring Multiple Supplies for Series Operation	3-12
Configuring Multiple Supplies for Parallel Operation	3-13
Sensing for Parallel Operation	3-13
Configuring Multiple Supplies for Split Supply Operation	3-14
Over Temperature Protection (OTP)	3-16
4 Remote Operation	
Introduction	4-2
Remote Analog Programming of Output Voltage and Current Limit	4-3
Remote Programming Options	4-3
Remote Analog Programming Procedure	4-3
Remote Monitoring of Output Voltage and Current	4-7
Readback Signals	4-7
5 Calibration and Troubleshooting	
Introduction	5-2
Calibration Setup	5-2
Service Environment and Precautions	5-2
Equipment Required	5-2
Accessing Calibration Potentiometer	5-3
Removing Option Card	5-3
Calibrating for Programming Accuracy	5-5
Voltage Programming Circuit Calibration	5-5
Current Limit Programming Circuit Calibration	5-6
Calibrating for Readback Accuracy	5-6
Output Voltage Monitor Circuit Calibration	5-7
Output Current Monitor Circuit Calibration	5-8
User Diagnostics	5-9
Emergency Shutdown	5-9
Unusual or Erratic Operation	5-9
Troubleshooting for Operators	5-10

A Specifications

Electrical Specifications ----- A-2
Additional Specifications ----- A-6
Input Conditions ----- A-6
Additional Features ----- A-8
Remote Programming and Monitoring ----- A-9
Environmental Specification -----A-10
Mechanical Specifications-----A-11

Warranty and Return Information ----- WA-1

Figures

Figure 1-1	Power Supply Front Panel	1-4
Figure 1-2	Power Supply Rear Panel	1-5
Figure 1-3	Programming and Monitoring SW1 Switch	1-7
Figure 1-4	Programming and Monitoring J2 Connector	1-9
Figure 2-1	Shipping or Storage Carton Label	2-6
Figure 2-2	AC Input Cover and Strain Relief	2-10
Figure 2-3	Maximum Load Wire Length for 1 V Line Drop	2-15
Figure 2-4	Bus Bar Shield	2-17
Figure 2-5	Typical Load Connection Hardware	2-18
Figure 2-6	Output Voltage Connector with Shield	2-20
Figure 2-7	Single Load with Local Sensing (Default)	2-21
Figure 2-8	Single Load with Remote Sensing	2-21
Figure 2-9	Multiple Loads with Local Sensing	2-23
Figure 2-10	Multiple Loads with Remote Sensing	2-23
Figure 2-11	J10 Sense Connector	2-25
Figure 2-12	Connecting Remote Sense Lines	2-27
Figure 3-1	Operating Modes	3-3
Figure 3-2	Series Operation of Multiple Supplies	3-12
Figure 3-3	Parallel Operation of Multiple Supplies	3-13
Figure 3-4	Split Supply Operation of Multiple Supplies	3-14
Figure 3-5	Split Supply Operation of Multiple Supplies	3-15
Figure 4-1	Connecting Programming Sources to J2 Connector	4-5
Figure 5-1	Programming and Monitoring Calibration Locations	5-4
Figure A-1	Typical Input Current Characteristics, 85-130 Vac Range	A-7
Figure A-2	Typical Input Current Characteristics, 190-264 Vac Range	A-7
Figure A-3	Current Derating for Rack Mounted 6 V Models	A-10
Figure A-4	Dimensional Drawings	A-12

Tables

Table 1-1	Available Voltage and Current Ranges - - - - -	1-2
Table 1-2	Rear Panel SW1 Switch Assignments - - - - -	1-7
Table 1-3	Rear Panel J2 Connector Terminals and Functions - - - - -	1-9
Table 2-1	Basic Setup Procedure - - - - -	2-2
Table 2-2	Operational AC Input Voltage Ranges and Frequency - - - - -	2-8
Table 2-3	AC Wire Specification - - - - -	2-8
Table 2-4	Current Carrying Capacity for Load Wiring - - - - -	2-15
Table 2-5	Rear Panel J10 Sense Connector Terminals and Functions - - - - -	2-25
Table 3-1	Shipped Configuration (Local Control Mode) - - - - -	3-5
Table 3-2	Switch Settings for Shutdown Circuit Logic- - - - -	3-10
Table 3-3	Switch Settings for Over Temperature Recovery Options- - - - -	3-16
Table 4-1	Remote Programming Options- - - - -	4-3
Table 4-2	Power Supply Settings for Different Programming Sources - - - - -	4-6
Table 4-3	Settings for Remote Monitoring of Readback Signals - - - - -	4-7
Table 5-1	User Diagnostics - - - - -	5-10
Table A-1	Electrical Specifications for 6 V to 35 V Models - - - - -	A-2
Table A-2	Electrical Specifications for 40 V to 600 V Models - - - - -	A-4

1

Introduction

[Chapter 1](#) describes the XFR 1200 Watt Series Programmable DC Power Supply and lists the features.

Description

This series of power supplies provides low-noise, precisely regulated, variable DC output at 1200 Watts of output power. Over voltage protection (OVP) and thermal shutdown are standard. Front panel controls and indicators are extensive. Select from several remote control choices: standard analog programming, optional isolated programming or readback, and optional GPIB programming or RS-232 control. Remote monitoring of output voltage and currents is a standard feature. Use this power supply either on your bench or in a standard 19 in. (483 mm) rack: the power supply occupies only 1.75 in. (1 U) of vertical rack space. Designed for continuous use in standalone or systems applications, this power supply is typically used to power DC equipment, control magnets, or burn in components. See [Table 1-1](#) for the list of available models.

Table 1-1 Available Voltage and Current Ranges

Model	Voltage Range	Current Range
6–200	0–6 V	0–200 A
7.5–140	0–7.5 V	0–140 A
12–100	0–12 V	0–100 A
20–60	0–20 V	0–60 A
35–35	0–35 V	0–33 A
40–30	0–40 V	0–30 A
60–20	0–60 V	0–20 A
100–12	0–100 V	0–12 A
300–4	0–300 V	0–4 A
600–2	0–600 V	0–2 A

Features and Options

- Simultaneous digital display of both voltage and current.
- Ten-turn front panel voltage and current controls for high resolution setting of the output voltage and current from zero to the rated output.
- Automatic mode crossover into current or voltage mode.
- Front panel push-button control of output standby mode and preview of voltage, current, or OVP setpoints. Front panel light emitting diode (LED) indicators for voltage and current mode operation, OVP, remote programming mode, and shutdown. Front panel control of OVP.
- Multiple units can be connected in parallel or in series to provide increased current or voltage.
- Thermal shutdown, latching or auto reset.
- Remote analog voltage and current limit programming with selectable programming ranges.
- External monitor signals for output voltage and current.
- Isolated analog remote programming control of the output voltage or current and isolated readback of output voltage and current with the optional ISOL Interface.
- Optional internal GPIB or RS-232 control for remote digital programming and readback from a computer.

Front Panel Controls

See [Figure 1-1](#) to review the controls, LEDs, and meters located on the power supply's front panel. Check the following sections for additional descriptions of front panel controls and functions.

- [“Mechanical Specifications” on page A-11](#)
- [“Functional Tests” on page 2-10](#)
- [Chapter 3, “Local Operation”](#)

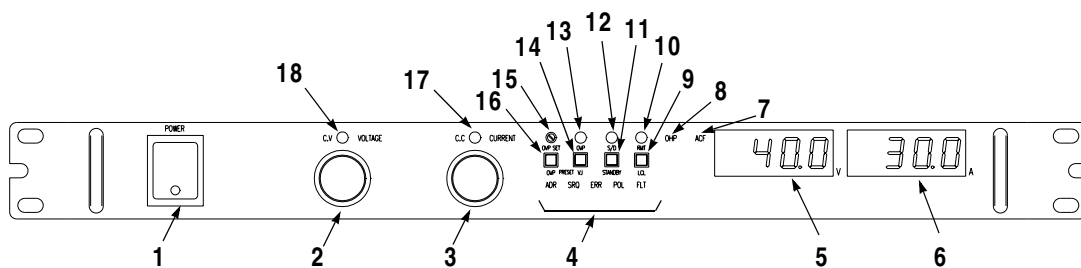

Figure 1-1 Power Supply Front Panel

Item	Description
1	AC Power Switch
2	Output Voltage Control Knob
3	Output Current Control Knob
4	Remote Programming LEDs. (For units with digital programming interface installed.)
5	Voltage Meter
6	Current Meter
7	AC Fail LED (ACF)
8	Over Temperature Protection LED (OTP)
9	Return to Local Programming (LOCAL) (For units with digital programming interface installed.)
10	Remote Programming LED (REM)
11	Standby Switch (STANDBY) (See page 3–9 for more information)
12	Shutdown LED (S/D)
13	OVP Shutdown LED (OVP)
14	Local Voltage and Current Limit Setting Preview Switch (V-I PRESET) (See page 2–10 for more information.)
15	OVP Adjust Potentiometer (OVP SET) (See page 3–7 for more information.)
16	OVP Setting Preview Switch (OVP CHECK) (See page 3–7 for more information.)
17	Current Mode LED
18	Voltage Mode LED

Rear Panel Connectors and Switch

Use the rear panel SW1 Programming, Monitoring, and Shutdown Select switch and the rear panel J2 Programming and Monitoring connector to choose among several remote programming and monitoring options. See [Figure 1-2](#) for the switches and connectors available at the rear panel. See [“Rear Panel SW1 Switch”](#) on page 1-7 and [“Rear Panel J2 Connector”](#) on page 1-9 for a list of switches and connector functions, and procedures for using them.

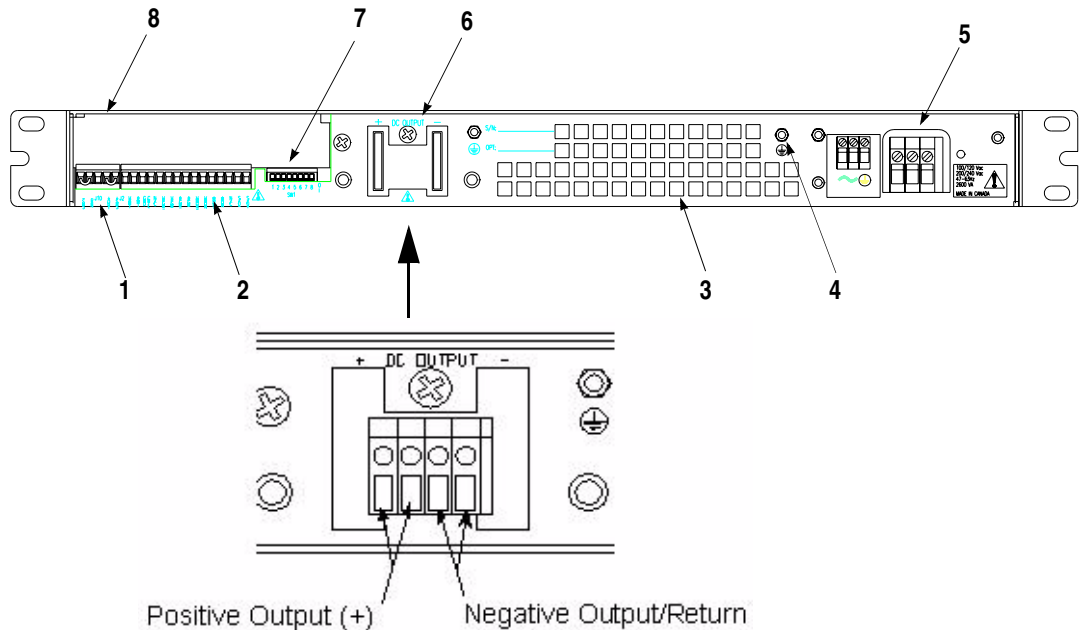

Figure 1-2 Power Supply Rear Panel

Item	Description
1	J10 Sense Connector (See page 2–23 for more information.) J10-1 Return Sense J10-2 Negative Output (Return) J10-3 No connection (N/C) J10-4 Positive Output J10-5 Positive Sense
2	J2 Programming and Monitoring Connector (See page 1–9 for more information.)
3	Fan Exhaust Vents (Do not block.)
4	Chassis Ground Screw
5	AC Input Connector (See page 2–6 for more information)
6	DC Output for Bus Bar Models (See inset in Figure 1-2 and page 2–13 for more information.)
7	SW1 Switch (See page 1–7 for more information.)
8	Blank Subplate (Replaced if digital programming interface installed.)

Rear Panel SW1 Switch

The SW1 Programming, Monitoring, and Shutdown Select switch is an 8-position piano DIP switch located on the power supply's rear panel. See [Figure 1-3](#). The SW1 switch enables you to choose:

- Resistive programming of output voltage or current limit
- Output voltage and current limit programming scales
- Output voltage and current monitor scales
- Remote shutdown circuit logic
- Over temperature shutdown mode

- 1 Resistive Programming of Output Voltage
- 2 Resistive Programming of Output Current
- 3 Selects Output Voltage Programming Source Range
- 4 Selects Output Current Limit Programming Source Range
- 5 Selects Output Voltage Monitor Range
- 6 Selects Output Current Monitor Range
- 7 Selects Remote Shutdown Logic
- 8 Selects Over Temperature Shutdown Reset Mode

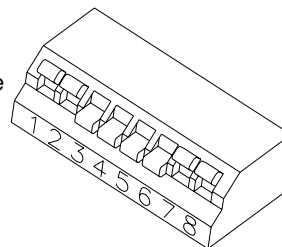

Figure 1-3 Programming and Monitoring SW1 Switch
(Switch is shown in factory default configuration)

[Table 1-2](#) shows the functions assigned to each SW1 switch. Factory defaults are underlined.

Table 1-2 Rear Panel SW1 Switch Assignments

Switch	Function	Open	Closed
SW1-1	1 mA current source for resistive programming of output voltage	<u>Voltage source programming</u>	Resistive programming (0-5 k, 0-10 k)
SW1-2	1 mA current source for resistive programming of output current limit	<u>Voltage source programming</u>	Resistive programming (0-5 k, 0-10 k)
SW1-3	Output voltage programming source range select	0-5 V (0-5 k)	<u>0-10 V</u> (0-10 k)
SW1-4	Output current limit programming source range select	0-5 V (0-5 k)	<u>0-10 V</u> (0-10 k)
SW1-5	Output voltage monitor range select	0-5 V	<u>0-10 V</u>
SW1-6	Output current monitor range select	0-5 V	<u>0-10 V</u>
SW1-7	Remote shutdown logic select	<u>HIGH=OFF</u>	HIGH=ON
SW1-8	Over temperature shutdown reset mode select	<u>Auto reset</u>	Latch OFF

Resetting the Switches

Before making any changes to the switch settings, disable the power supply output by pushing the front panel STANDBY switch to its IN position. This temporarily shuts down the power supply. The front panel S/D LED turns on. Then use any small, flat-bladed screwdriver to change the switch settings.

Any of the eight switches on SW1 is OFF (OPEN) when it has been flipped up to break contact, ON (CLOSED) when flipped down to close contact.

Rear Panel J2 Connector

The J2 Programming and Monitoring connector is a 15-terminal wire clamp connector located on the power supply's rear panel. See [Figure 1-4](#). The J2 connector provides access to the following functions:

- Remote programming of output voltage AND/OR current limit
- Remote monitoring of calibrated readback signals for output voltage and output current
- Remote control of the shutdown function using a 2.5 V to 15 V signal

1 Remote Output Voltage Programming Select
2 Remote Output Current Limit Programming Select
3 Control Ground
4 N/C
5 Voltage Program Signal Return
6 Output Voltage Programming Input
7 Current Program Signal Return
8 Output Current Limit Programming Input
9 Voltage Monitor Signal Return
10 Output Voltage Monitor
11 Current Monitor Signal Return
12 Output Current Monitor
13 N/C
14 Shutdown (S/D) Signal Return (-)
15 S/D Input (+)

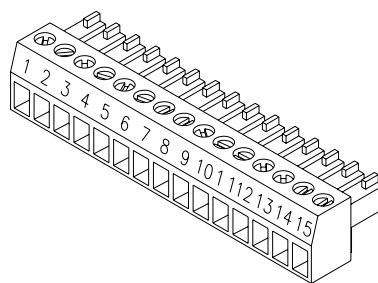

Figure 1-4 Programming and Monitoring J2 Connector

See [Table 1-3](#) for the list of the J2 connector terminal numbers, their references, and corresponding functions.

Table 1-3 Rear Panel J2 Connector Terminals and Functions

Connector	Reference	Name	Function
J2-1	VRMT	Remote Output Voltage Programming Select	Selects remote output voltage programming when jumpered to pin 3.
J2-2	IRMT	Remote Output Current Limit Programming Select	Selects remote output current limit programming when jumpered to pin 3.
J2-3	CNTL GND	Control ground.	Control ground.
J2-4	N/C	No connection	None
J2-5	VPGM–	Voltage Program Signal Return	Return for voltage program signal.
J2-6	VPGM	Output Voltage Programming Input	Input for voltage programming signals from an analog device.
J2-7	IPGM–	Current Program Signal Return	Return for current program signal.
J2-8	IPGM	Output Current Limit Programming Input	Input for current limit programming signals from an analog device.
J2-9	VMON–	Voltage Monitor Signal Return	Return for voltage monitor signal.
J2-10	VMON	Output Voltage Monitor	Output for output voltage monitor signal.
J2-11	IMON–	Current Monitor Signal Return	Return for current monitor signal.
J2-12	IMON	Output Current Monitor	Output for output current monitor signal.
J2-13	N/C	No connection	None.
J2-14	S/D–	Shutdown Signal Return (–)	Return for shutdown signal.
J2-15	S/D+	S/D Input (+)	Input for shutdown signal.

Making J2 Connections



CAUTION

Do not attempt to bias program/monitor signal return (J2 terminals 5, 7, 9, and 11) relative to the supply output because control ground (J2-3) and the program/monitor signal returns are at the same potential as the power supply return in a standard unit. Use the Isolated Programming (ISOL) interface option to allow control from a programming source at a different potential relative to the supply's output.



CAUTION

To maintain the isolation of the power supply output and prevent ground loops, use an isolated (ungrounded) programming source when operating the power supply via remote analog control at the J2 connector.

Make connections to the J2 connector using its screw-type wire clamps. Before making any connections, turn the power supply OFF and wait until the front panel displays have gone out. You can unplug the connector from the back of the unit in order to make it easier to install the required wiring.

Wiring



WARNING: Shock hazard

There is a potential shock hazard at the output when using a power supply with a rated output greater than 40 V. Use load wiring with a minimum insulation rating equivalent to the maximum output voltage of the power supply. For example, select TEW-105, 105 °C, 600 V wiring for use with a 600 V, 2 A model power supply.

For most connectors and jumpers, use any suitable wire such as 16 to 24 AWG stranded wire. For lowest noise performance, use shielded pair wiring of 16 to 24 AWG. Strip wires 0.26 in. (6.5 mm), insert, and tighten the wire clamp.

2

Installation

[Chapter 2](#) explains basic setup procedures. It describes inspection, cleaning, shipping, and storage procedures. Includes AC input connection, basic functions testing, and load and sense lines connections.

Introduction

This section provides recommendations and procedures for inspecting, installing, and testing the power supply.

Basic Setup Procedure

See [Table 2-1](#) for a summary of the basic setup procedure and an overall view of the subsections in this section. Use the procedure as a quick reference if you are familiar with the installation requirements for the power supply. If you want more information, each step in the procedure refers to subsequent sections which contain more details. Execute each step in the sequence given.

Table 2-1 Basic Setup Procedure

Step #	Description	Action	Reference
1	Inspection	Perform an initial physical inspection of the supply.	“Inspection, Cleaning, and Packaging” on page 2–3
2	Installation	Install the supply (bench or rack mount), ensuring adequate ventilation.	“Location, Mounting, and Ventilation” on page 2–5
3	Input Power	Connect AC input power.	“AC Input Power Connection” on page 2–6
4	Test	Perform functional tests for voltage mode operation, current mode operation, and front panel controls.	“Functional Tests” on page 2–10
5	Load	Connect the load.	“Load Connection” on page 2–13
6	Sensing	Connect sense lines.	“Local and Remote Sensing” on page 2–23

See [“Local Operation”](#) for instructions for front panel operation, OVP and OTP, shutdown, and using multiple supplies. You will find remote programming and monitoring described in [“Remote Operation”](#).

Inspection, Cleaning, and Packaging

Initial Inspection

When you first receive your unit, perform a quick physical check.

1. Inspect the unit for scratches and cracks, and for broken switches, connectors, and displays.
2. Ensure that the packing box contains the AC input cover and strain relief kit (see [Figure 2-2](#)). For 60 V to 600 V models, check that the box also contains the output cable strain relief (see [Figure 2-6](#)). For all models, the output connector shield is already installed.
3. Have the service technician check the printed circuit board and its components if you suspect internal damage.

If the unit is damaged, save all packing materials and notify the carrier immediately. See packing instructions in “[Packaging for Shipping or Storage](#)” on page 2–3.

Periodic Cleaning

No routine servicing of the power supply is required except for periodic cleaning. Whenever a unit is removed from operation, clean the metal surfaces with naphtha or an equivalent solvent and the front panel with a weak solution of soap and water. Use low-pressure compressed air to blow dust from in and around components on the printed circuit boards.

Packaging for Shipping or Storage

Follow these instructions to prepare the unit for shipping or storage.

1. When returning the unit or sending it to the service center, attach a tag to the unit stating its model number (available from the front panel label) and its serial number (available from the rear panel label). Give the date of purchase and an invoice number, if you have it, as well as a brief description of the problem.
2. For storage or shipping, repack the power supply in its original container. If the original container is not available, seal the unit in a plastic bag and then pack it in a 200 lb. (90 kg) test, corrugated cardboard carton large enough to allow 2 inches (5 cm) of cushioning material to surround the unit. Use a material such as foam slabs or chips.

3. Label the carton as shown in [Figure 2-1](#).
4. If shipping, mark the address of the service center and your return address on the carton.
5. If storing, stack no more than eight cartons high. Check the storage temperature range and storage altitude specification in [“Environmental Specification”](#) on page A-10.

POWER SUPPLY

Model Number: _____

Serial Number: _____

FRAGILE — ELECTRONIC EQUIPMENT

Figure 2-1 Shipping or Storage Carton Label

Location, Mounting, and Ventilation

Use the power supply in rack-mounted or in benchtop applications.

Rack Mounting

The power supply is designed to fit in a standard 19 in. (483 mm) equipment rack.

To install the power supply in a rack:

1. Use the integral rack-mount ears at both sides of the front panel to install the power supply in a rack.
2. Provide adequate support for the rear of the unit without obstructing the ventilation inlets on the sides of the unit. Use a support bar at the rear of the unit. Follow the manufacturer's instructions to install the support bar.

Angle Bracket Mounting Rack mount slides are not suitable for the 1200 Watt unit, however, angle brackets are available from the manufacturer.

Ventilation

Whether you place the power supply in a rack or on a bench, allow cooling air to reach the ventilation inlets on the sides of the unit and allow 4 in. (100 mm) of unrestricted air space at the rear of the unit for the fan exhaust. Any ventilation space at the top and bottom of the supply will further lower internal operating temperatures.

Check “[Environmental Specification](#)” on page A-10 for the operating ambient temperature range and the operating altitude specification.

AC Input Power Connection



WARNING: Shock hazard

Disconnect AC power from the unit before removing the cover. Even with the front panel power switch in the OFF position, live line voltages are exposed when the cover is removed. Repairs must be made by experienced service technicians only.



WARNING: Shock hazard

There is a potential shock hazard if the power supply chassis and cover are not connected to an electrical ground via the safety ground in the AC input connector. Ensure that the power supply is connected to a grounded AC outlet with the recommended AC input connector configured for the available line voltage as described in this section.



CAUTION

When power switch is turned on, output voltage or current previously set will be applied to loads.

AC Input Connector and Voltage Selection

The AC input connector is a 3-terminal wire clamp located on the power supply's rear panel. See [Figure 2-2 on page 2-9](#).

Auto Range Select



CAUTION

To prevent damage to the power supply, turn off AC power to the unit before changing from one AC input voltage range to another.

The Auto Range Select function built into the 1200 Watt unit allows you to connect to either low or high AC input voltages without making any adjustments to the unit. We warrant that the unit will perform to specification at AC input voltage ranges 85 to 130 Vac and 190 to 264 Vac. See [Table 2-2](#). Between these ranges (at 130 to 190 Vac), the unit will operate normally, although full performance to specification cannot be guaranteed.

Table 2-2 Operational AC Input Voltage Ranges and Frequency

AC Voltage Range	Frequency
85-130 Vac 1 ϕ (20 A maximum at 120 Vac) ^a	47-63 Hz
190-264 Vac 1 ϕ (12 A maximum at 230 Vac)	47-63 Hz

a.6 V model: 95-130 Vac

AC Fail LED

The AC Fail (ACF) LED turns on when the input voltage is outside of the range specified for the power supply. The LED turns off when the input voltage is within the range.

AC Input Cord



WARNING:

The AC input cord is the disconnect device for the power supply. The plug must be readily identifiable by and accessible to the operator. The input cord must be no longer than 9.84 feet (3 m).

The AC input cord we recommend is specified in [Table 2-3](#). Add a non-locking plug suitable for use in the country in which you are operating. If you require a special cord, contact the manufacturer.

Table 2-3 AC Wire Specification

Wire Size	Ratings	Cable Outside Diameter
3 x 12 AWG stranded copper	60 °C minimum, 300 V	0.545-0.708 in. (13.63-17.7 mm)
3 x 16 AWG stranded copper ^a	60 °C minimum, 300 V	0.545-0.708 in. (13.63-17.7 mm)

a.Alternate choice for 190-264 Vac input only.

AC Input Wire Connection

To make the AC input wire connections:

1. Strip the outside insulation on the AC cable approximately 4 in. (100 mm). Trim the wires so that the ground wire is 0.5 in. (12 mm) longer than the other wires. Strip 0.55" (14 mm) at the end of each of the wires. See [Figure 2-2](#) detail (top).
2. Unscrew the base of the strain relief from the helix-shaped body. Insert the base through the outside opening in the AC input cover and, from the inside, screw the locknut securely onto the base.
3. Slide the helix-shaped body onto the AC cable. Insert the stripped wires through the strain relief base until the outer cable jacket is flush with the edge of the base. Tighten the body to the base while holding the cable in place. The cable is now securely fastened inside the strain relief.
4. Route the AC wires to the input connector terminals as required. For input connector terminal locations, see lower inset in [Figure 2-2](#). To connect the wiring, loosen the terminal screw, insert the stripped wire into the terminal, and tighten the screw securely.
5. Route the wires inside the cover to prevent pinching. Fasten the AC input cover to the unit using the 6-32 x 1 1/4 in. (2) screws, flat washers, and lock washers provided. See [Figure 2-2](#).

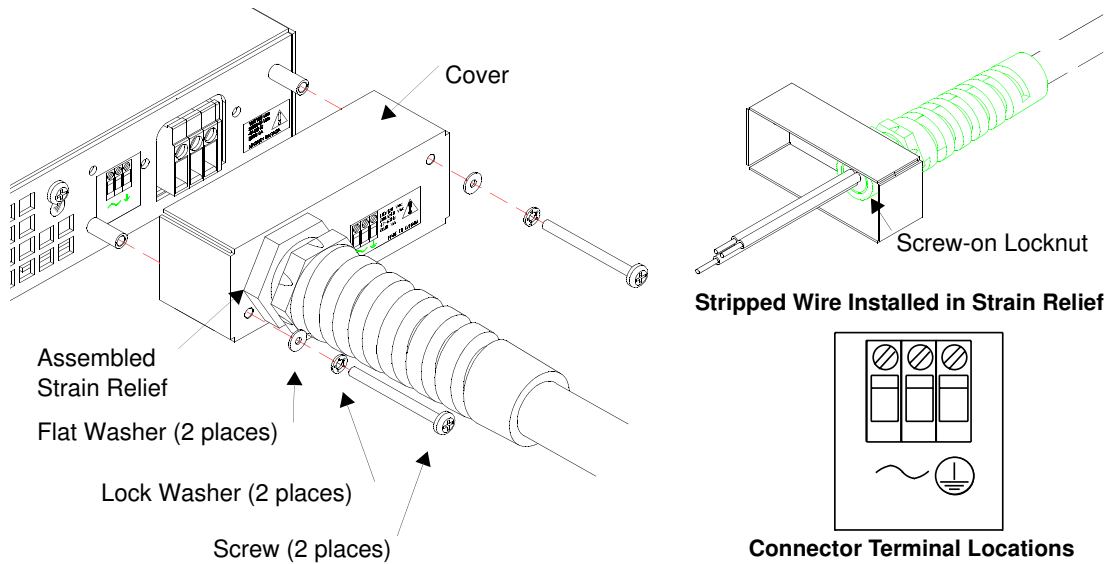

Figure 2-2 AC Input Cover and Strain Relief

Functional Tests

These functional test procedures include power-on and front panel function checks as well as voltage and current mode operation checks.

Equipment Required

- Digital voltmeter (DVM) rated better than 0.5% accuracy.
- DC shunt 1mV/A ($\pm 0.25\%$) with connecting wire. The recommended current ratings for the DC shunt and the wire must be at least 10% more than the output current of the power supply.

Power-on Check

To perform the power-on check:

1. Ensure that the AC power switch is in the OFF position.
2. Ensure that the output sense lines are connected in the default configuration. (The local sense lines are connected between terminals 1 and 2 and between terminals 4 and 5 on the J10 sense connector as shown on the rear panel diagram in [Figure 1-2 on page 1-5](#).)
3. Turn the voltage and current controls fully counter-clockwise.
4. Connect the unit to an AC outlet.
5. Turn the front panel AC power switch to ON.

After a short power-on delay, the front panel digital meters light up and the green voltage mode LED turns on. Both voltmeter and ammeter displays read zero.

Voltage Mode Operation Check

To perform the voltage mode operation check:

1. Ensure the voltage and current controls on the front panel are turned fully counter-clockwise.
2. Connect a DVM to the output terminals on the rear panel, observing correct polarity.
3. Turn the current control a 1/2-turn clockwise. Slowly turn the voltage control clockwise and observe both the front panel voltmeter and the DVM.
4. Compare the DVM reading with the front panel voltmeter reading to verify the accuracy of the internal voltmeter. Both readings should be the same. The minimum control range is from zero to the maximum rated output for the power supply model. The voltage mode LED turns on.
5. Turn the front panel AC power switch to OFF.

Current Mode Operation Check

To perform the current mode operation check:

1. Ensure that the front panel power switch is set to OFF.
2. Turn the voltage and current controls on the front panel fully counter-clockwise.
3. Connect the DC shunt across the output terminals on the rear panel.
4. Connect the DVM across the DC shunt.
5. Turn the AC power switch to ON.
6. Turn the voltage control one (1) or two (2) turns clockwise.
7. Turn the current control slowly clockwise.
8. Compare the DVM reading with the front panel ammeter reading using $I=V/R$ where I is the current, V is the DVM reading, and R is the DC shunt resistance. The minimum control range is from zero to the maximum rated output for the power supply model. The current mode LED turns on.
9. Turn the front panel power switch to OFF.
10. Disconnect the DVM and the shunt.

Front Panel Function Checks

To perform the front panel function checks:

1. Turn the front panel power switch to ON.
2. Set voltage and current controls fully clockwise. Push the STANDBY switch to its IN position and check that the voltmeter reading falls to zero and the red S/D (Shutdown) LED turns on. Push the STANDBY switch once again to reset it to its OUT position. The S/D LED turns off and the voltmeter reading returns to its previous value.
3. Press the STANDBY switch to its IN position.
4. Press the OVP CHECK switch and check that the voltmeter displays approximately the model-rated output voltage plus 10%.
5. Turn the OVP SET potentiometer counter-clockwise and check that the voltmeter reading decreases. Continued turning (up to 20 turns) will see the reading decrease to approximately 5% of the model-rated voltage output. Turn the OVP SET potentiometer clockwise until the voltmeter once again displays approximately the model-rated output voltage plus 10%.
6. Press the STANDBY switch to its OUT position.
7. Press the V/I CHECK switch and check that the voltmeter and ammeter display approximately the power supply output ratings.
8. Turn the front panel power switch to OFF.

Important: You can use the front panel LOCAL button only when a digital programming interface has been installed in your power supply.

Load Connection

This section provides recommendations for load wires and how to connect them for both single and multiple load configurations.

Load Wiring

To select wiring for connecting the load to the power supply, consider the following factors:

- insulation rating of the wire
- current carrying capacity of the wire
- maximum load wiring length for operation with sense lines
- noise and impedance effects of the load lines

Insulation Rating

Use load wiring with a minimum insulation rating equivalent to the maximum output voltage of the power supply. For example, select TEW-105, 105 °C, 600 V wiring for use with a 600 V, 2 A model power supply.

Current Carrying Capacity

As a minimum, load wiring must have a current capacity greater than the output current rating of the power supply. This ensures that the wiring will not be damaged even if the load is shorted. [Table 2-4](#) shows the maximum current rating, based on 450 A/cm^2 , for various gauges of wire rated for 105 °C operation. Operating at the maximum current rating results in an approximately 30 °C temperature rise for a wire operating in free air. Where load wiring must operate in areas with elevated ambient temperatures or bundled with other wiring, use larger gauges or wiring rated for higher temperatures.

Table 2-4 Current Carrying Capacity for Load Wiring

Wire Size (AWG)	Max. Current (A)	Wire Size (AWG)	Max. Current (A)
20	2.5	6	61
18	4	4	97
16	6	2	155
14	10	1	192
12	16	1/0	247
10	21	2/0	303
8	36		

Load Wiring Length for Operation with Sense Lines

For applications using remote sensing, you must limit the voltage drop across each load line. [Figure 2-3](#) shows some allowable wire lengths for a given load current and wire size. We recommend that you use the larger load wiring to ensure a smaller voltage drop (1 V typical maximum), although units will compensate for up to 5 V drop in each line. See also “[Local and Remote Sensing](#)”.

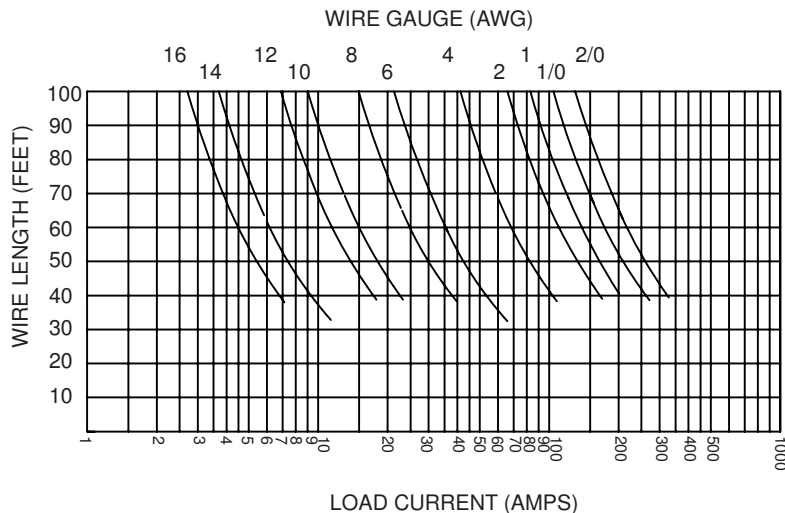

Figure 2-3 Maximum Load Wire Length for 1 V Line Drop

Noise and Impedance Effects

To minimize noise pickup or radiation, use shielded pair wiring of shortest possible length for load wires. Connect the shield to the chassis via a rear panel mounting screw. Where shielding is impossible or impractical, simply twisting the wires together will offer some noise immunity. When using local sense connections, use the largest practical wire size to minimize the effects of load line impedance on the regulation of the supply.

Making Load Connections



WARNING: Shock hazard

There is a shock hazard at the load when using a power supply with a rated output greater than 40 V. To protect personnel against accidental contact with hazardous voltages, ensure that the load, including connections, has no live parts which are accessible. Also ensure that the insulation rating of the load wiring and circuitry is greater than or equal to the maximum output voltage of the power supply.



CAUTION

When making connections to the bus bars, ensure that each terminal's mounting hardware and wiring assembly are placed to avoid touching the other terminal and shorting the power supply output. Heavy connecting cables must have some form of strain relief to avoid loosening the connections or bending the bus bars.

Make load connections at the rear of the power supply at the positive and negative output bus bars or to the 4-terminal wire clamp connector, depending on the model.

6 V to 40 V Models

The 6 V to 40 V (low voltage) models have output bus bars and may come with a bus bar shield in some configurations. To detach the shield before connecting load wires, remove 6-32 x 1/4 in. screws (2), 6-32 x 3/8 in. screw (1), and lock washers and flat washers (3 places). See [Figure 2-4](#).

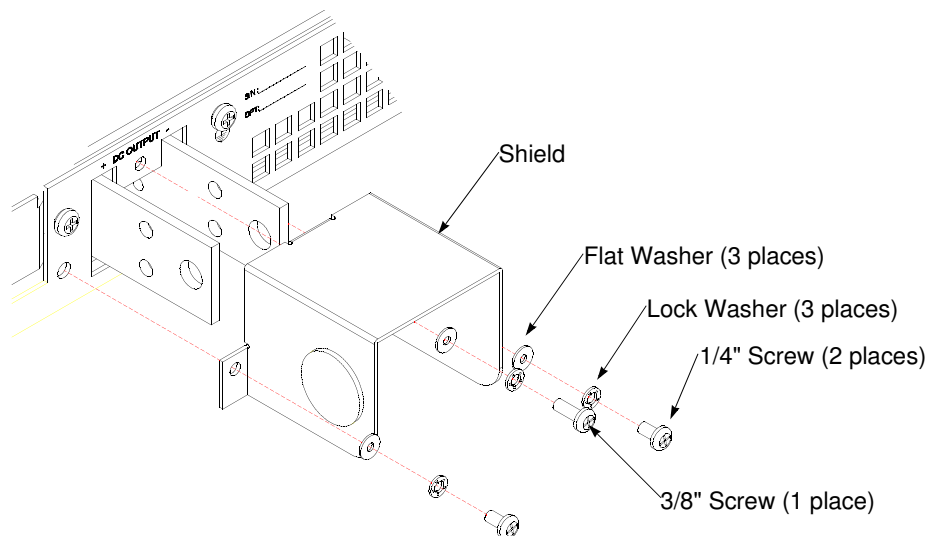

Figure 2-4 Bus Bar Shield

To make load connections to a 6 V to 40 V power supply:

1. Install a connecting wire terminal lug to load wiring (see [Figure 2-5](#)).
2. Fasten wire terminal lugs to bus bars with 1/4 in. x 1/2 in. (M6 x 12 mm) screws, 1/4 in. (M6) internal tooth lock washers, and hex nuts as shown in [Figure 2-5](#).

Important: Bus bar hole sizes for the 6 V to 40 V models (low voltage) are: 1 of 0.332" (8.17 mm) D; and 2 of 0.197" (5.0 mm) D.

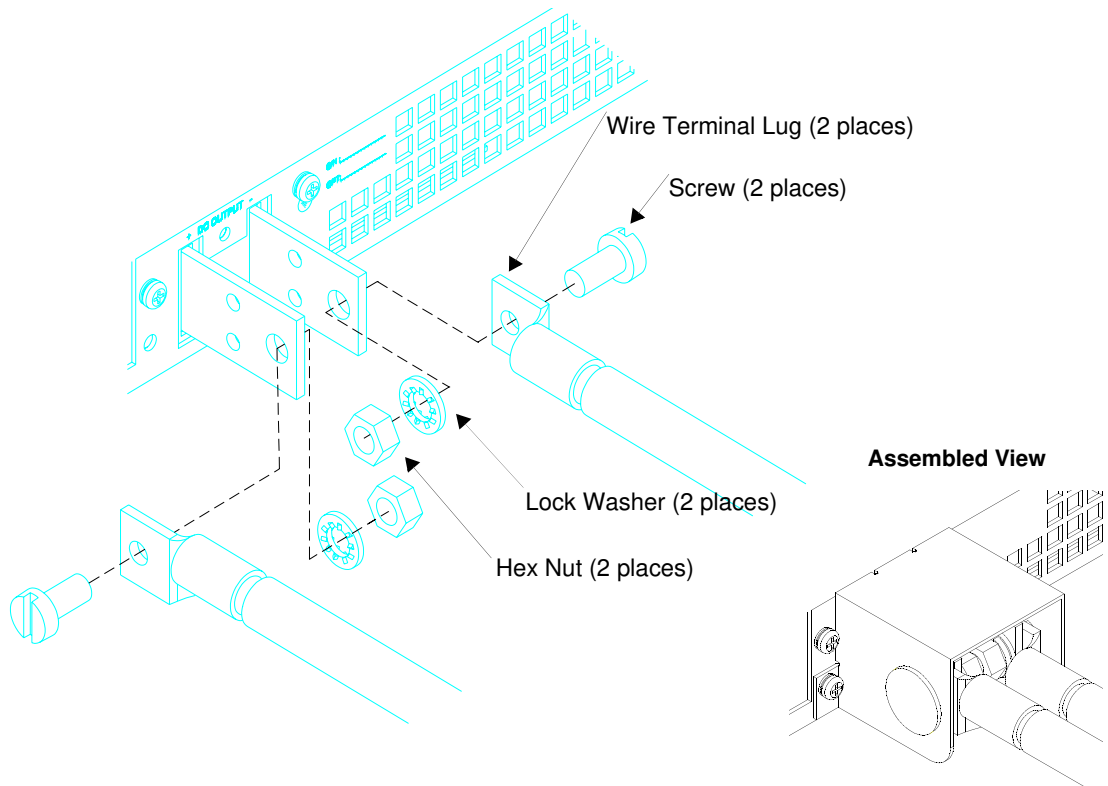

Figure 2-5 Typical Load Connection Hardware
(6 V to 40 V Models)

60 V to 600 V Models



WARNING: Shock hazard

To protect personnel against accidental contact with hazardous voltages, ensure that the load, including connections, has no live parts which are accessible. Also ensure that the insulation rating of the load wiring and circuitry is greater than or equal to the maximum output voltage of the power supply.



WARNING: Sharp edges

Wear protective gloves and use caution when removing the circular knockout from the shield as described below. The exposed metal edges of the knockout may be sharp.

The 60 V to 600 V (high voltage) models have a 4-terminal, wire clamp output connector. See inset of [Figure 2-6](#) for a labelled drawing of the wire clamp connector. The units are shipped with a protective shield attached (see [Figure 2-6](#)).

To make load connections to a 60 V to 600 V power supply:

1. Use a gloved finger or a blunt tool to push in the circular knockout on the right side (recommended) of the shield. After you push in the knockout, twist it until it detaches from the shield, and discard.
2. Insert the bushing of the small black strain relief, screw-side out, through the knockout hole, pushing in from the outside of the shield. You will hear a snap as the strain relief attaches securely to the shield.
3. Strip insulation 0.35" (9 mm) at the end of each of the wires.
4. Loosen the strain relief screw and route the wires through the strain relief.
5. Loosen the connector terminal screw (see inset in [Figure 2-6](#)), insert the stripped wire into the terminal, and tighten the terminal screw securely.
6. Ensure that the wires are not pulled too taut between the terminals and the strain relief. Tighten the strain relief screw.

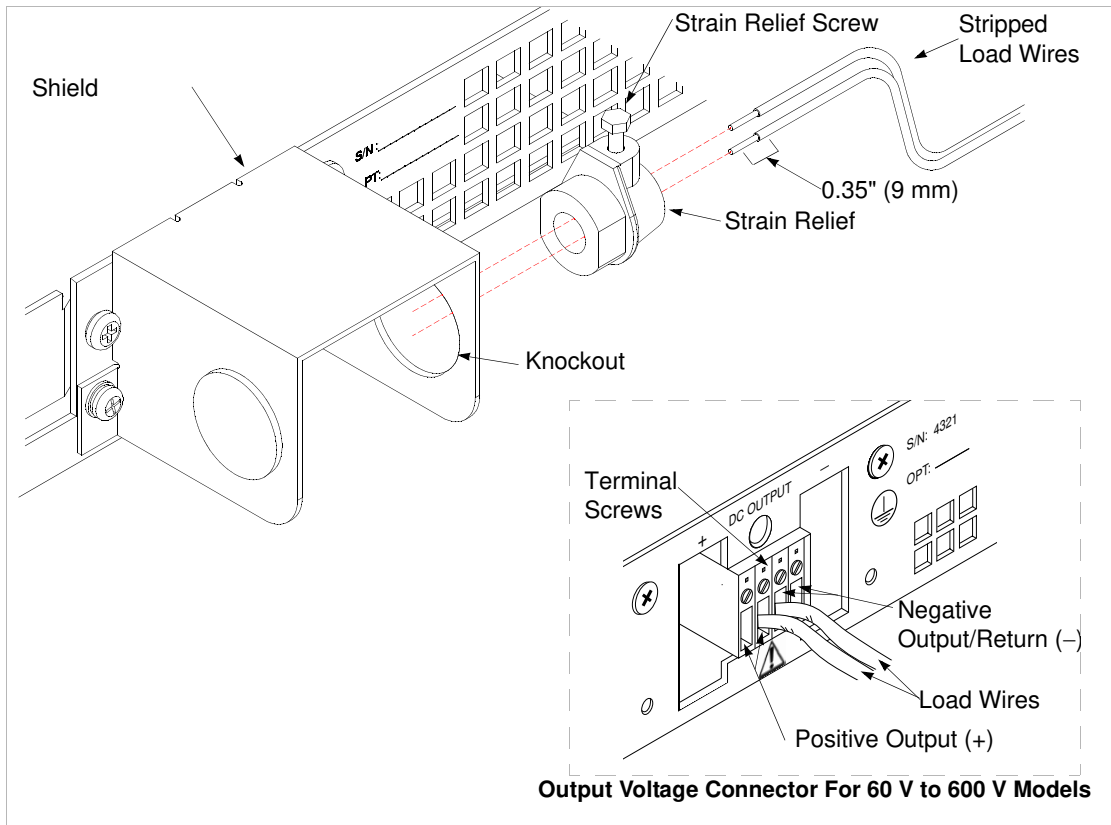

Figure 2-6 Output Voltage Connector with Shield
(For 60 V to 600 V models)

Inductive Loads

To prevent damage to the power supply from inductive kickback, connect a diode across the output. The diode must be rated at greater than or equal to the supply's output voltage and have a current surge rating greater than or equal to the supply's output rating. Connect the cathode to the positive output and the anode to the negative output/return.

Where positive load transients such as back EMF from a motor may occur, connect a transorb or a varistor across the output to protect the power supply. The breakdown voltage rating for the transorb or varistor must be approximately 10% higher than the rated supply output.

Connecting Single Loads

Figure 2-7 and Figure 2-8 show recommended load and sensing connections for single loads. Local sense lines shown are default connections at the rear panel J10 sense connector.

You do not need remote sensing for basic operation of your supply. However, if you wish to correct any small drops in your load lines, then use the remote sensing feature. See “Local and Remote Sensing” on page 2-23 for more information.

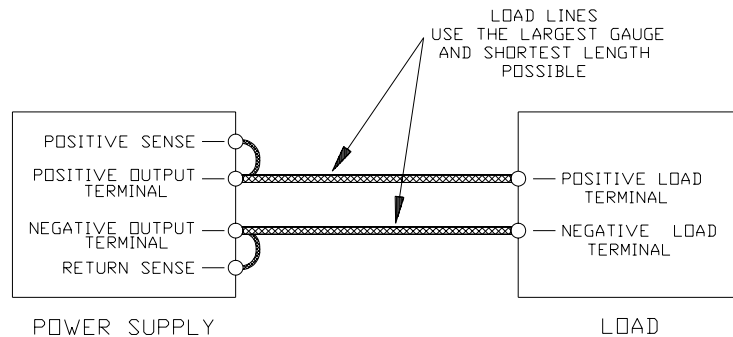

Figure 2-7 Single Load with Local Sensing (Default)

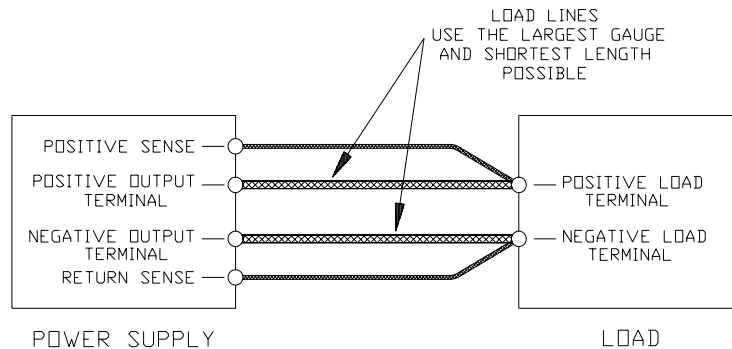

Figure 2-8 Single Load with Remote Sensing

Connecting Multiple Loads

Proper connection of distributed loads is an important aspect of power supply use. Two common methods of connection are the parallel power distribution method and the radial power distribution method.

Parallel Power Distribution

This distribution method involves connecting leads from the power supply to one load, from that load to the next load, and so on for each load in the system. This method results in the voltage at each load depending on the current drawn by the other loads and allows DC ground loops to develop. Except for low current applications, we do not recommend using this method.

Radial Power Distribution Method

To connect distributed loads, we recommend that you use radial power distribution. With this method, you connect power to each load individually from a single pair of terminals designated as the positive and negative distribution terminals. These terminals may be the power supply output terminals, the terminals of one of the loads, or a distinct set of terminals especially established for distribution use. Connect the sense leads to these terminals to compensate for losses and minimize the effect of one load upon another.

[Figure 2-9](#) and [Figure 2-10](#) show recommended load and sensing connections for multiple loads. Local sense lines shown are default J10 sense connections. See [“Local and Remote Sensing” on page 2–23](#) for more information about using remote sensing, and about grounding the sense line shield.

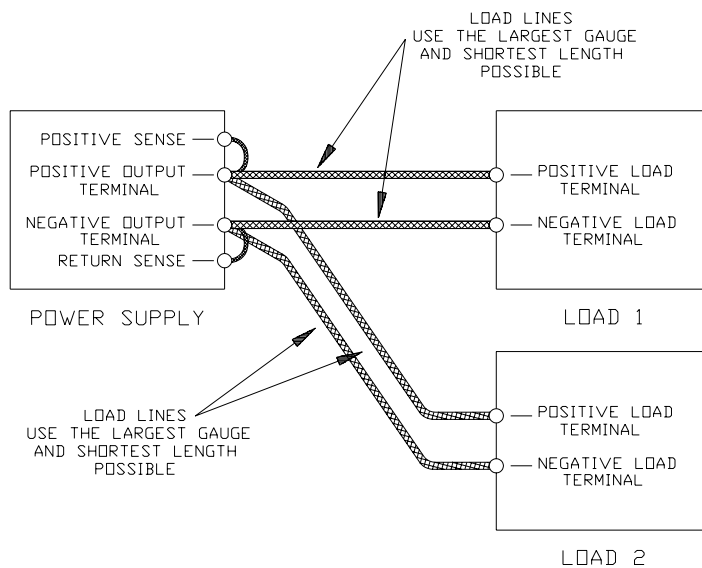

Figure 2-9 Multiple Loads with Local Sensing

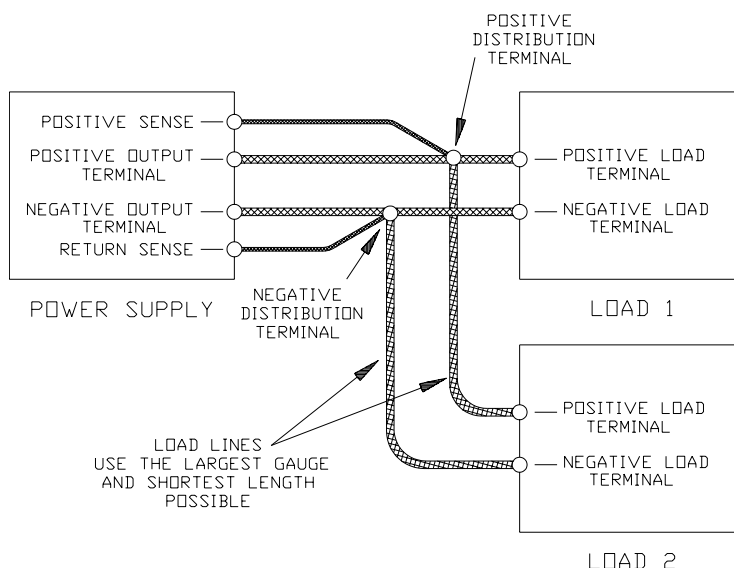

Figure 2-10 Multiple Loads with Remote Sensing

Local and Remote Sensing

Use connections at the rear panel J10 sense connector to configure the power supply for local or remote sensing of output voltage. See [Figure 2-11](#) for a drawing of the sense connector.

Sense Wiring



WARNING

There is a potential shock hazard at the sense connector when using a power supply with a rated output greater than 40 V. Select wiring with a minimum insulation rating equivalent to the maximum output voltage of the power supply for use as local sense jumpers or for remote sense wires. For example, select TEW-105, 105 °C, 600 V wiring for use with a 600 V, 2 A model power supply. Ensure that connections at the load end are shielded to prevent contact with hazardous voltages.

For lowest noise performance, use shielded pair wiring of 16 to 24 AWG for remote sense lines. Strip wires 0.26 in. (6.5 mm), insert and tighten the wire clamp.

Local Sensing

We ship the power supply with the rear panel J10 sense connector jumpered for local sensing of the output voltage. See [Table 2-5](#) for the list of connector functions and a description of local sense connections. With local sensing, the output voltage is regulated at the output terminals (or bus bars). This method does not compensate for voltage losses in the load lines, so it is recommended only for low current applications or applications for which load regulation is not essential.

Important: When using local sense connections, use the largest practical load wire size to minimize the effects of line impedance on the regulation of the supply.

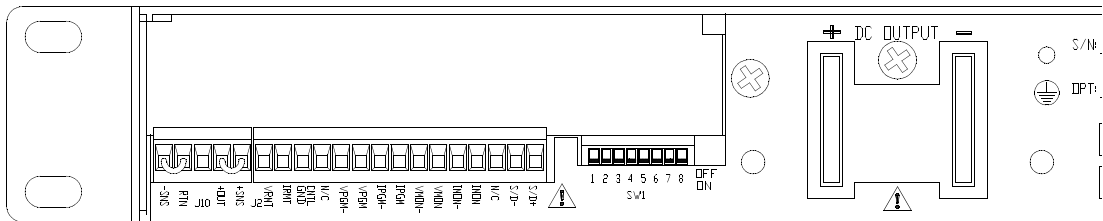

Figure 2-11 J10 Sense Connector
(Shown with local sense jumpers connected)

Table 2-5 Rear Panel J10 Sense Connector Terminals and Functions

Terminal	Name	Function
J10-1	Return Sense (-SNS)	Remote negative sense connection. Default connection to terminal 2.
J10-2	Negative Output (Return or RTN)	Connected internally to negative output.
J10-3	N/C	No connection.
J10-4	Positive Output (+OUT)	Connected internally to positive output.
J10-5	Positive Sense (+SNS)	Remote positive sense connection. Default connection to terminal 4.

Using Remote Sensing



WARNING

There is a potential shock hazard at the sense points when using a power supply with a rated output greater than 40 V. Ensure that connections at the load end are shielded to prevent contact with hazardous voltages.



CAUTION

Ground the sense line shield in one place only. Locations include: the power supply's return output connection at the load, the power supply's return output at its negative output terminal, or at the power supply's chassis.



CAUTION

Do not use remote sensing with multiple supplies connected in series.

Use remote sensing during voltage mode operation to shift the power supply's regulation point from its default position at the rear panel output terminals to the load or distribution terminals by using a separate pair of wires to allow the control circuitry to monitor the load voltage. This allows the power supply to compensate for voltage losses in the load lines which will otherwise degrade the regulation of the supply. Line drop is subtracted from the total voltage available at the output.

To connect remote sense lines:

1. Turn OFF the power supply.
2. Remove the local sense jumpers connecting J10 mating connector terminal 5 (positive sense) to terminal 4 (positive output) and terminal 1 (return sense) to terminal 2 (power supply return).
3. Connect the positive remote sense lead to J10 mating connector terminal 5 (positive sense) and the negative lead to terminal 1 (return sense). Ensure the mating connector is plugged securely into the rear panel sense connector. Connect the other ends of the sense wires to the corresponding sense points at the load.
4. To prevent ground loops, ground the sense line shield, at one point only, to the power supply's return output connection at the load, to the power supply's return output at its negative output terminal, or to the power supply's chassis.

5. Turn ON the power supply.

Important: If you operate the power supply with remote sense lines connected to the load and with either of the positive or negative load lines not connected, the shutdown circuit will activate, causing the output voltage and current to fall to zero

If you operate the power supply without remote sense lines or local sense jumpers in place, the supply will continue to work, but supply regulation will be degraded and/or erratic; or, the OVP circuit may activate.

Figure 2-12 shows a sample setup for using remote sensing.

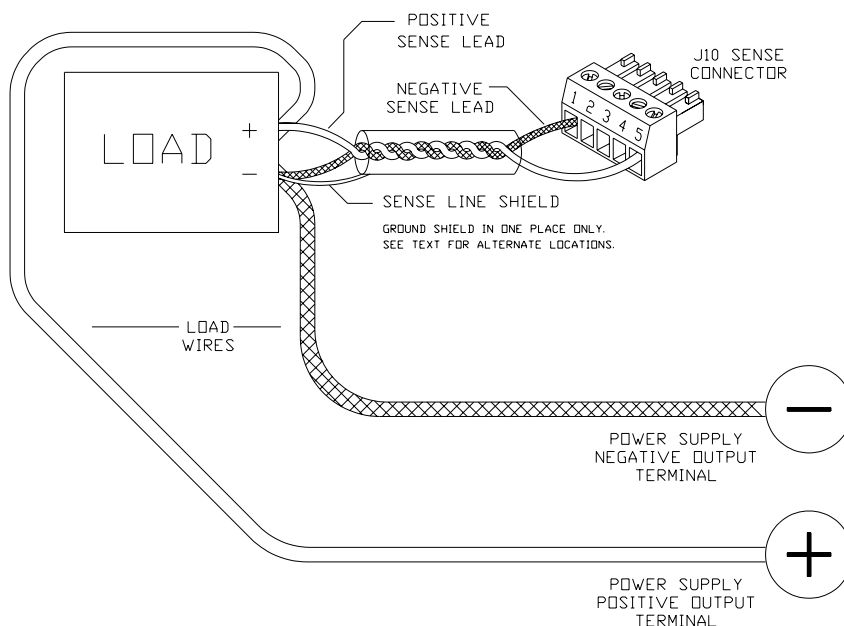

Figure 2-12 Connecting Remote Sense Lines

3

Local Operation

[Chapter 3](#) provides procedures for local (front panel) operation. It includes procedures for using over voltage protection, shutdown function, multiple supplies, and over temperature protection.

Introduction

Once you have installed the power supply and have connected both the AC input power and the load as covered in “[Installation](#)”, the power supply is ready to operate in local control mode (that is, operation at the unit’s front panel).

- See “[Standard Operation](#)” on page 3–3 for a brief explanation of Constant Voltage and Constant Current Mode operation.
- See “[Using Over Voltage Protection \(OVP\)](#)” on page 3–7 to “[Over Temperature Protection \(OTP\)](#)” on page 3–16 for more about power supply functions such as OVP, shutdown function, OTP, and using multiple supplies.
- See “[User Diagnostics](#)” on page 5–9 for troubleshooting information for the operator.
- Turn to “[Remote Operation](#)” for descriptions of remote programming options and remote monitoring of the power supply.

Standard Operation

This power supply has two basic operating modes: Constant Voltage Mode and Constant Current Mode, and two control modes: Local Control Mode (default setting) and Remote Programming Mode. Both operating modes are available regardless of which control mode is used.

Operating Modes and Automatic Crossover

Whether controlled by local or remote programming, the power supply has two basic operating modes: Constant Voltage Mode and Constant Current Mode. The mode in which the power supply operates at any given time depends on the combination of:

- output voltage setting V_{SET}
- output current limit setting I_{SET}
- resistance of the attached load R_L

See [Figure 3-1](#) for a graphical representation of the relationships between these variables.

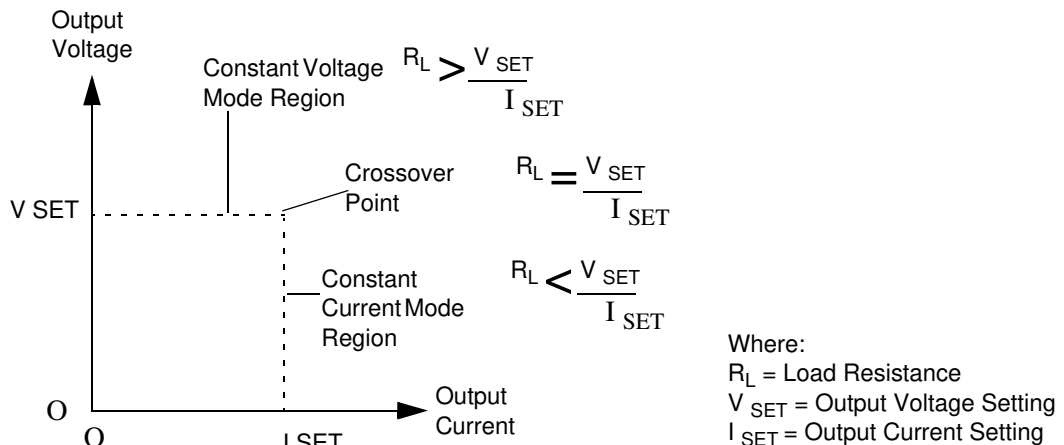

Figure 3-1 Operating Modes

Constant Voltage Mode Operation

The power supply will operate in constant voltage mode whenever the load current I_L is less than the current limit setting I_{SET} , or: $I_L < I_{SET}$ (Note: $I_L = V_{SET} / R_L$).

In constant voltage mode, the power supply maintains the output voltage at the selected value (V_{SET}) while the load current I_L varies with the load requirements.

Constant Current Mode Operation

The power supply will operate in constant current mode whenever the load resistance is low enough that the load current I_L is equal to the current limit setting I_{SET} (Note: $V_L = I_{SET} R_L$).

In constant current mode, the power supply maintains the output current at the selected value (I_{SET}) while the load voltage varies with the load requirements.

Automatic Mode Crossover

This feature allows the power supply to automatically switch operating modes in response to changing load requirements. If, for example, the power supply was operating in Constant Voltage Mode ($I_L < I_{SET}$), and the load changed so that the load current (I_L) became equal to the current limit setting (I_{SET}), the power supply would automatically switch into Constant Current Mode and the output voltage would vary in response to changes in load current. If the additional load was subsequently removed so that the load current was again less than the current limit setting, the supply would automatically return to Constant Voltage Mode.

Shipped Configuration

The factory ships units already configured for local control (front panel) operation. See [Table 3-1](#) for a summary of this configuration.

Table 3-1 Shipped Configuration (Local Control Mode)

Local Control Configuration	Additional References
Use the front panel controls to adjust the output voltage and current limit settings. (Note: Use the LOCAL button only when you have a digital programming interface installed.)	See “ Local Operation ” for front panel operation. See “ Remote Operation ” for remote analog programming procedure(s).
The supply’s sense point is at the rear panel J10 sense connector terminals.	See page 2–23 for information on how to change from local to remote sensing.
The OVP set point is adjusted at the front panel to approximately 110% of rated output voltage.	See “ Using Over Voltage Protection (OVP) ” on page 3–7 for the adjustment procedure.
The over temperature shutdown function automatically resets when activated as determined by the position of rear panel switch SW1-8. A latch off setting is also available.	See “ Over Temperature Protection (OTP) ” on page 3–16 for more information about switch SW1-8 settings.

Setting Output Voltage and Current Limit

Install the power supply and connect the load as described in “[Installation](#)”. Ensure that the power supply is set up for local control as described in “[Shipped Configuration](#)” on page 3–5.

To set the output voltage and current limit at the front panel:

1. Turn both the voltage and current controls fully counter-clockwise.
2. Turn the AC power ON.
3. Press the STANDBY switch to its IN position to disable the power supply output. The red Shutdown (S/D) LED turns on.
4. Press and hold the V/I CHECK button to display the voltage and current control settings on the voltmeter and ammeter displays.
5. Adjust the voltage control to the desired voltage (the compliance voltage for applications using current mode operation).
6. Adjust the current control to the desired current limit setting.
7. Release the V/I CHECK button.
8. Press the STANDBY switch to its OUT position to apply power to the load. The S/D LED turns off.

Important: The control circuits have been designed to allow you to set output voltage and current up to 5% over the model-rated maximum values. The power supply will operate within these extended ranges, but we cannot guarantee full performance to specification.

Using Over Voltage Protection (OVP)

The OVP circuit protects the load in the event of a remote programming error, an incorrect voltage control adjustment, or a power supply failure. The protection circuit monitors the output voltage at the output of the power supply and will shut down the main power converter whenever a preset voltage limit is exceeded. Set the preset voltage limit (also called the set point or trip level) using the screwdriver-adjustable, front panel OVP potentiometer, or via one of the optional GPIB or RS-232 programming interfaces.

Important: The default preset limit is approximately 110% of the rated output voltage.

When using OVP with remote sensing lines connected, compensate for the voltage line drop across the output return line by measuring or calculating the line drop, then adding this value to the desired OVP setpoint.

Front Panel OVP Operation

In local control mode, check the OVP set point at any time by pressing the OVP CHECK switch. The OVP set point is the value displayed on the digital voltmeter.

To set the trip level from the front panel:

1. Disconnect any loads. Turn the power supply ON.
2. Adjust the power supply output voltage to any voltage lower than the desired trip level.
3. Press the front panel STANDBY (output shutdown) switch to its IN position. The red S/D LED turns on.
4. Press the OVP CHECK switch to see the OVP set point on the voltmeter display.
5. Holding down the OVP CHECK switch, turn the OVP SET potentiometer until the desired set point is reached. Release the OVP CHECK switch.
6. Press the STANDBY switch to its OUT position. The S/D LED turns off.
7. To check that the power supply shuts off at the desired set point, slowly increase the output voltage while monitoring the front panel voltmeter. The OVP LED on the front panel turns on when the OVP circuit activates.

Resetting the OVP Circuit

To reset the OVP circuit after it activates:

1. Reduce the power supply's output voltage setting to below the OVP set point.
2. Press the STANDBY switch IN. The red S/D LED on the front panel turns on. The OVP LED turns off.
3. Press the STANDBY switch again to return power to the load and resume normal operation.

OR

1. Reduce the power supply's output voltage setting to below the OVP set point.
2. Turn the power supply OFF using the AC power switch, wait until the front panel displays go out, then turn the power supply back ON again.

Using the Shutdown Function

Use the shutdown function to disable or enable the supply's output so that you can make adjustments to either the load or the power supply without shutting off the power supply. Activate this function from the front panel at any time by using the STANDBY switch. You can also activate it via remote control through the rear panel J2 Programming and Monitoring connector, using a 2.5 V to 15 V signal or a transistor-transistor logic (TTL) compatible signal. The input lines for the Shutdown circuit are optically isolated.

STANDBY Switch

The STANDBY switch is a press ON/press OFF switch located on the power supply's front panel. Push the switch to its IN position to activate the shutdown circuit. The output voltage and current fall to zero and the red S/D (Shutdown) LED turns on. Push the switch once more to reset it to its OUT position and resume normal power supply operation.

Controlling the Shutdown Function via the J2 Connector

The shutdown circuit accepts a 2.5 V to 15 V signal to disable or enable the power supply output. Make connections for signals at connector J2, located on the unit's rear panel. Set rear panel switch SW1-7 to select signal logic. See [“Rear Panel Connectors and Switch” on page 1–5](#) for more information about making J2 connector and SW1 switch changes.

To activate the shutdown function:

1. Turn OFF the power supply.
2. Connect the signal source to J2 connector terminal 15 (Shutdown Input/positive) and terminal 14 (Shutdown Return).
3. Set switch SW1-7 to select the desired circuit logic as set out in [Table 3-2](#).
4. Turn on the power supply. The power supply will operate as described in the Supply Output column in [Table 3-2](#), according to the logic that you select and the level of the input signal. The S/D (Shutdown) LED on the front panel turns on when the Shutdown circuit is activated.

Table 3-2 Switch Settings for Shutdown Circuit Logic

Switch SW1-7 Setting	Source Signal	Signal Level	Supply Output	S/D LED
OFF (OPEN) (Active low, default)	2-15 V	HIGH	OFF	ON
	0-0.4 V	LOW	ON	OFF
ON (CLOSED) (Active high)	2-15 V	HIGH	ON	OFF
	0-0.4 V	LOW	OFF	ON

Important: If switch SW1-7 is ON but there is no signal applied, the S/D LED turns on and the power supply will not provide an output until the HIGH signal level is applied.

Any of the eight switches on SW1 is OFF (OPEN) when it has been flipped up to break contact, ON (CLOSED) when flipped down to close contact.

Using Multiple Supplies



WARNING

There is a shock hazard at the load when using a power supply with a rated *or combined* output greater than 40 V. To protect personnel against accidental contact with hazardous voltages created by series connection, ensure that the load, including connections, has no live parts which are accessible. Also ensure that the insulation rating of the load wiring and circuitry is greater than or equal to the maximum *or combined* output voltage of the power supply.



CAUTION

Do not connect power supplies from different manufacturers in parallel or in series.



CAUTION

The remote programming inputs are internally referenced to the supply's negative output. Do not connect remote programming ground lines (J2 terminals 3, 5, and 7) to the supply's positive output.

You can operate power supplies of the **SAME MODEL** with outputs in series or in parallel to obtain increased load voltage or increased current. Split supply operation gives you two positive outputs, or a positive and a negative output.

Important: If your application requires the use of isolated programming inputs, contact the manufacturer about the optional ISOL interface.

Configuring Multiple Supplies for Series Operation



CAUTION

Do not use remote sensing during series operation.
The maximum allowable sum of the output voltages is 600 Vdc.

Use series operation to obtain a single higher voltage output using two or more supplies. Connect the negative (–) output terminal of one supply to the positive (+) output terminal of the next supply. See [Figure 3-2](#). The total voltage available is the sum of the maximum voltages of each supply (add voltmeter readings, to a maximum of 600 V). The maximum allowable current for a series string of power supplies is the output current of a single supply in the string.

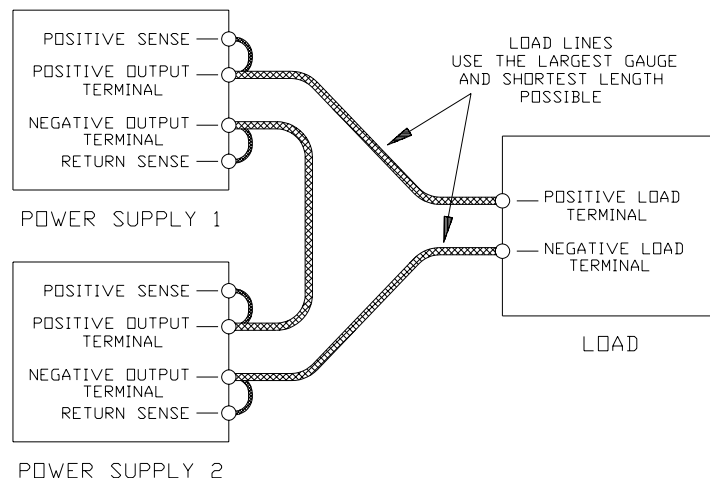

Figure 3-2 Series Operation of Multiple Supplies

(Local sense lines shown are default J10 connections.)

Configuring Multiple Supplies for Parallel Operation

Use parallel operation to obtain a higher current through a single output using two or more supplies. Set all of the OVP setpoints to maximum. (See “Using Over Voltage Protection (OVP)” on page 3–7.) Set all of the outputs to the same voltage before connecting the positive (+) output terminals and negative (–) output terminals in parallel. See Figure 3-3. The total current available is the sum of the maximum currents of each supply.

When operating multiple supplies in parallel, the operating mode of each supply depends on the load current being drawn. For example, with two 40 V, 30 A model power supplies operating in parallel with a 50 A load, one supply operates in constant current mode supplying 30 A and the other supply operates in voltage mode supplying the remaining 20 A. The level of current sharing between units depends on how accurately the output voltages are matched.

Important: If you do not fix the OVP setpoints at maximum, the OVP circuit may trip on one unit, reducing the current available to the load.

Sensing for Parallel Operation

Use default local sensing to enhance power sharing between units, as the impedance of the load lines will tend to correct for current imbalance. If you use remote sensing at the load for better voltage regulation, one supply always operates in current limit mode and supplies most of the power.

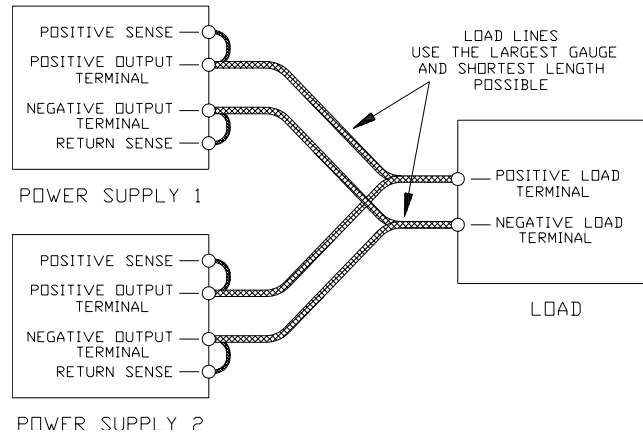

Figure 3-3 Parallel Operation of Multiple Supplies

(Local sense lines shown are default J10 connections.)

Configuring Multiple Supplies for Split Supply Operation

Split supply operation uses two power supplies to obtain two positive voltages with a common ground, or to obtain a positive-negative supply.

Two Positive Voltages To obtain two positive voltages, connect the negative output terminals of both supplies together in a common connection. The positive output terminals will provide the required voltages with respect to the common connection. See [Figure 3-4](#).

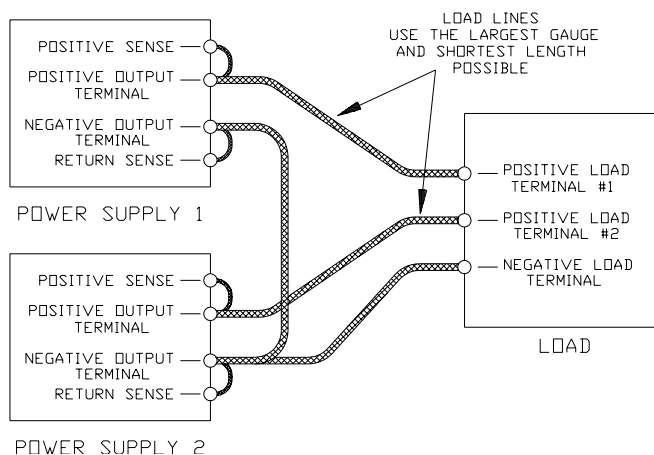

Figure 3-4 Split Supply Operation of Multiple Supplies

(Two Positive Voltages; Local sense lines shown are default J10 connections.)



CAUTION

To prevent possible damage to the supply, do not connect the remote program return line of the negative supply to the common connection.

To obtain a positive-negative supply, connect the negative output terminal of one supply to the positive output terminal of the second supply. The positive output terminal of the first supply then provides a positive voltage relative to the common connection while the negative output terminal of the second supply provides a negative voltage. You can set the current limits independently. The maximum current available in split supply operation is equal to the rated output of the supplies. For example, 30 A for two 40 V, 30 A models. See [Figure 3-5](#).

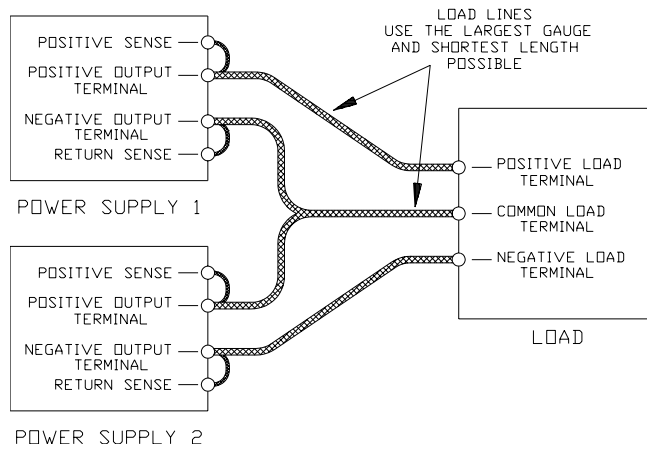

Figure 3-5 Split Supply Operation of Multiple Supplies

(Positive-negative Supply; Local sense lines shown are default J10 connections.)

Over Temperature Protection (OTP)

The OTP function allows you to select how the power supply recovers from an over temperature shutdown using the rear panel switch SW1-8. See [Table 3-3](#) for the switch settings and selections. See “[Rear Panel Connectors and Switch](#)” on [page 1–5](#) for more information about the switch. The OTP shutdown circuit activates before the internal components can exceed their safe internal operating temperatures. When an OTP shutdown occurs, the front panel OTP LED turns on.

Table 3-3 Switch Settings for Over Temperature Recovery Options

Switch SW1-8	OTP Shutdown Selection	Description
OFF (OPEN)	Auto Reset (Default)	The supply recovers to normal operation when the over temperature condition no longer exists.
ON (CLOSED)	Latch OFF	After an over temperature shutdown, the supply stays off until you turn the AC power switch OFF, then you turn the power supply ON to continue use.

4

Remote Operation

[Chapter 4](#) details remote analog programming operation and remote monitoring of output voltage and current.

Introduction

The rear panel switches and connector on the power supply allow you to program the supply with an analog device or to output readback signals. This section covers the following topics:

- See “[Remote Analog Programming of Output Voltage and Current Limit](#)” on page 4–3 for procedures covering remote analog programming of output voltage and current limit with 0-5 V and 0-10 V voltage sources and 0-5 k and 0-10 k resistances.
- See “[Remote Monitoring of Output Voltage and Current](#)” on page 4–7 for more about the connector and switch settings for using calibrated readback signals for output voltage and output current with selectable 0-5 V or 0-10 V scales.

Isolated Programming The 4-channel Isolated (ISOL) Programming Interface is an internal card which can be ordered as an option. It allows remote programming and readback of the power supply’s output voltage and current limit with 0-5 V analog signals at a different voltage potential relative to the power supply’s output. Contact the manufacturer to order the ISOL Interface.

Remote Digital Programming You can operate the power supply from a computer if you have had the GPIB or RS-232 Interface card installed as an option. Refer to the separate interface manual for all setup and operation instructions for remote digital programming.

Remote Analog Programming of Output Voltage and Current Limit

Remote analog programming allows control of the power supply's output voltage and/or current limit to shift from local operation at the front panel voltage and current controls to external analog sources. As you vary the external programming source, the power supply's output varies proportionally over its output range.

Using remote analog programming requires that you reset switch SW1 and make connections to the J2 connector on the power supply's rear panel. See [“Rear Panel Connectors and Switch” on page 1–5](#).

Remote Programming Options

See [Table 4-1](#) for a summary of the options available to you for programming output voltage and current limit using an analog source.

Table 4-1 Remote Programming Options

Control of...	Programming Scales ^a
Output Voltage and/or	0-5 V and 0-10 V voltage sources
Current Limit	0-5 k and 0-10 k resistances

a. These scales may be used in any combination.

Remote Analog Programming Procedure



CAUTION

To maintain the isolation of the power supply output and prevent ground loops, use an isolated (ungrounded) programming source when operating the power supply via remote analog control at the J2 connector.



CAUTION

The remote programming inputs are internally referenced to the supply's negative output. Do not connect control ground (J2 terminals 3, 5, or 7) to the supply's positive output.

To set up remote analog programming:

1. Turn the power supply OFF.
2. Set switches SW1-1, SW1-2, SW1-3, and SW1-4 according to the programming sources that you are using, as indicated in [Table 4-2](#). See Notes at the end of this procedure for more information about switch settings.
3. Install any required J2 connector jumpers as indicated in [Table 4-2](#).
4. Connect the programming source(s) to the mating J2 connector as shown in [Figure 4-1](#) and observe the correct polarity for voltage sources. Ensure that the mating connector is plugged securely into the rear panel connector.
5. Set the programming sources to the desired levels and turn the power supply ON. The REM LED turns on. Adjust the external programming source to change the power supply's output.

Please remember:

- Any of the eight switches on SW1 is OFF (OPEN) when it has been flipped up to break contact, ON (CLOSED) when flipped down to close contact.
- Resetting switches SW1-3 or SW1-4, the programming scale selection switches, may require that you recalibrate the programming circuit to maintain programming accuracy. See [“Calibration and Troubleshooting”](#).
- Switches SW1-5, SW1-6, SW1-7, and SW1-8 are not required for remote programming. They remain at the settings you have selected for your application.
- Switches SW-1 to SW-4 can be set to their defaults (1 and 2 open, 3 and 4 closed) unless otherwise specified in [Table 4-2](#). See [“Rear Panel SW1 Switch”](#) on page 1–7 for default settings.
- The control circuits have been designed to allow you to set output voltage and current up to 5% over the model-rated maximum values. The power supply will operate within these extended ranges, but we cannot guarantee full performance to specification.

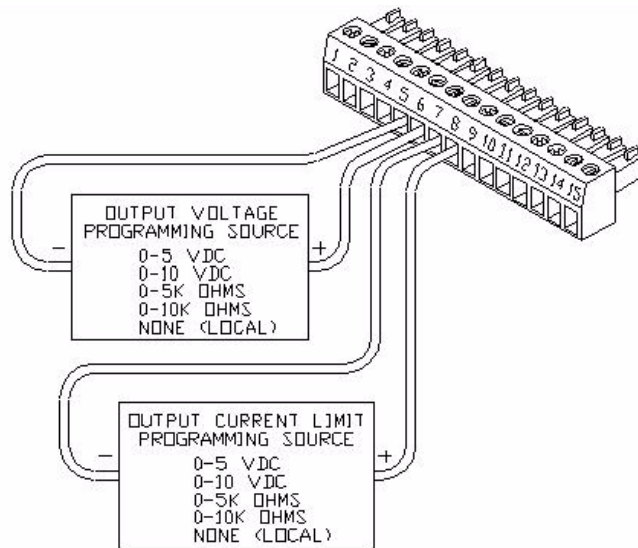

Figure 4-1 Connecting Programming Sources to J2 Connector

Table 4-2 Power Supply Settings for Different Programming Sources

Output Voltage Programming Source	Output Current Limit Programming Source				
	0-5 Vdc	0-10 Vdc	0-5 k Resistor	0-10 k Resistor	None (Front Panel Control)
0-5 Vdc	SW1: set 3 and 4 open. J2: jumper 1 to 3 and 2 to 3.	SW1: set 3 open. J2: jumper 1 to 3 and 2 to 3.	SW1: set 2 closed, 3 and 4 open. J2: jumper 1 to 3 and 2 to 3.	SW1: set 2 closed, 3 open. J2: jumper 1 to 3 and 2 to 3.	SW1: set 3 open. J2: jumper 1 to 3.
0-10 Vdc	SW1: set 4 open. J2: jumper 1 to 3 and 2 to 3.	SW1: default settings. J2: jumper 1 to 3 and 2 to 3.	SW1: set 2 closed, 4 open. J2: jumper 1 to 3 and 2 to 3.	SW1: set 2 closed. J2: jumper 1 to 3 and 2 to 3.	SW1: default settings. J2: jumper 1 to 3.
0-5 k Resistor	SW1: set 1 closed, 3 and 4 open. J2: jumper 1 to 3 and 2 to 3.	SW1: set 1 closed, 3 open. J2: jumper 1 to 3 and 2 to 3.	SW1: set 1 and 2 closed, 3 and 4 open. J2: jumper 1 to 3 and 2 to 3.	SW1: set 1 and 2 closed, 3 open. J2: jumper 1 to 3 and 2 to 3.	SW1: set 3 open, 1 closed. J2: jumper 1 to 3.
0-10 k Resistor	SW1: set 1 closed, 4 open. J2: jumper 1 to 3 and 2 to 3.	SW1: set 1 closed. J2: jumper 1 to 3 and 2 to 3.	SW1: set 1 and 2 closed, 4 open. J2: jumper 1 to 3 and 2 to 3.	SW1: set 1 and 2 closed. J2: jumper 1 to 3 and 2 to 3.	SW1: set 1 closed. J2: jumper 1 to 3.
None (Front Panel Control)	SW1: set 4 open. J2: jumper 2 to 3.	SW1: default settings. J2: jumper 2 to 3.	SW1: set 2 closed, 4 open. J2: jumper 2 to 3.	SW1: set 2 closed. J2: jumper 2 to 3.	SW1: default settings. J2: no jumper

Remote Monitoring of Output Voltage and Current

Readback Signals

The J2 connector on the rear panel provides access to calibrated readback signals for remote monitoring of the output voltage and current. Rear panel switches SW1-5 and SW1-6 allow you to select either a 0-5 Vdc or a 0-10 Vdc range for the output. The readback signal represents 0 to 100% of the power supply's output.

See [Table 4-3](#) for the required J2 connections and switch settings for remote monitoring of readback signals with 0-5 Vdc or 0-10 Vdc outputs. Use shielded pair wiring (20 to 24 AWG) and ground the shield to J10 sense connector terminal 1 (return sense) or to the chassis.

Table 4-3 Settings for Remote Monitoring of Readback Signals

Readback Signal	J2 Connection Signal (+)	J2 Connection Return (-)	Switch SW1 Setting
Output Voltage (0-5 Vdc)	J2-10	J2-9	SW1-5 OFF (OPEN)
Output Voltage (0-10 Vdc)	J2-10	J2-9	SW1-5 ON (CLOSED)
Output Current (0-5 Vdc)	J2-12	J2-11	SW1-6 OFF (OPEN)
Output Current (0-10 Vdc)	J2-12	J2-11	SW1-6 ON (CLOSED)

Important: Check the readback accuracy any time you reset switches SW1-5 and SW1-6. See [“Calibration and Troubleshooting”](#).

5

Calibration and Troubleshooting

Chapter 5 details remote analog programming operation and remote monitoring of output voltage and current. It also provides troubleshooting information.

Introduction



WARNING: High energy and high voltage

Exercise caution when using and calibrating a power supply. High energy levels can be stored at the output voltage terminals on a power supply in normal operation. In addition, potentially lethal voltages exist in the power circuit and on the output and sense connectors of a power supply with a rated output greater than 40 V. Filter capacitors store potentially dangerous energy for some time after power is removed.

Adjustments to programming and readback accuracy for the power supply are made using cover-off procedures which must be performed by a service technician.

Calibration Setup

Service Environment and Precautions

- Follow established antistatic procedures.
- Work at a bench with adequate room and support for the test unit and for all equipment required.
- To reduce shock hazard, use only an insulated, straight-bladed screwdriver when calibrating trim potentiometers.
- NEVER calibrate these units alone. Ensure that someone is present who can help should an accident occur.

Equipment Required

You will need the following equipment when calibrating your power supply.

- 5 1/2-digit true RMS voltmeters (DVMs) ($\pm 0.05\%$ accuracy) with test leads
- Current shunt 1 mV/AMP ($\pm 0.25\%$) and connecting wire. The recommended current ratings for the DC shunt and connecting wire must be at least 10% greater than the power supply's output current rating. See also [Table 2-4 on page 2-14](#).
- Non-conducting, straight-bladed screwdriver

Accessing Calibration Potentiometer

**WARNING**

Disconnect AC power from the unit before removing the cover. Even with the front panel power switch in the OFF position, live line voltages are exposed when the cover is removed. Repairs and adjustments must be made by experienced service technicians only.

**WARNING**

Use a non-conducting, straight-bladed screwdriver to adjust the trim pots.

**CAUTION**

Follow established antistatic procedures. There are static-sensitive parts on the printed circuit boards.

You will need to remove the power supply's cover to access the programming and readback calibration potentiometers which are located on the A2 PCB. See [Figure 5-1](#) to locate the potentiometers.

Removing Option Card

If there is a GPIB or RS-232 option card (PCB) installed inside the power supply, you will have to remove it to access the calibration potentiometers.

Tool Required: Phillips #2 screwdriver

To remove the option card:

1. Turn OFF the power supply. Disconnect AC Power. Remove the cover.
2. Remove four screws from their standoffs inside the power supply to release the option card.
3. Remove two screws at the rear panel to release the option card's subplate.
4. Unplug the ribbon cable connectors from the option card. Lift out card.

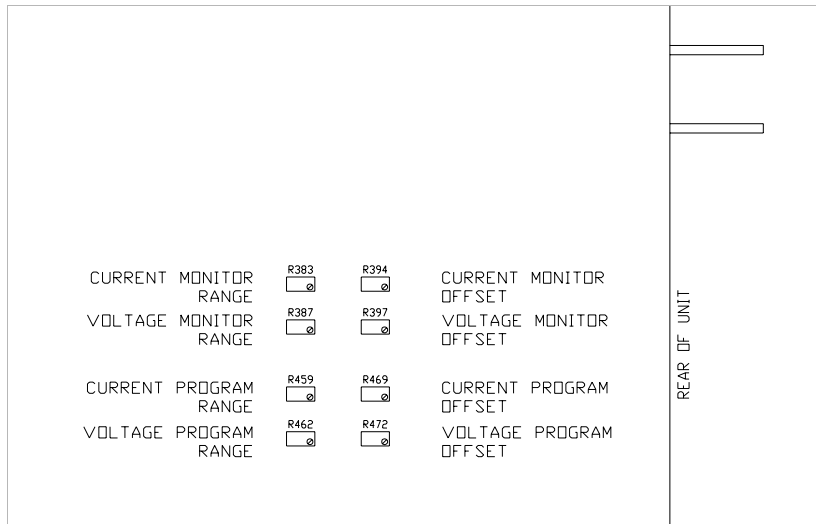

Figure 5-1 Programming and Monitoring Calibration Locations
(Top view.)

Calibrating for Programming Accuracy

The factory calibrates the offset and range of the voltage and current programming circuits to within 1% for the default 0-10 Vdc programming signals. You may need to recalibrate when you use 0-5 Vdc programming or when you switch back to 0-10 Vdc programming after previously calibrating for 0-5 Vdc programming.

See “[Calibration Setup](#)” on page 5–2 for the procedures to remove the cover and any option card. Follow all procedure steps in the sequence given.

Voltage Programming Circuit Calibration

To perform voltage programming circuit calibration:

1. Ensure that the power supply is turned OFF. Disconnect any load.
2. Connect the program source between J2 connector terminals 6 (output voltage program input) and 5 (voltage program signal return).
3. Connect the DVM across the power supply output.
4. Turn the power supply ON.
5. Apply 1% of program voltage.
6. Adjust the voltage program offset potentiometer (R472) until the DVM reads 1% of the model-rated output voltage.
7. Apply 100% of program voltage.
8. Adjust the voltage program range potentiometer (R462) until the DVM reads the model-rated output voltage.

Repeat this procedure until output levels are adjusted to specifications (see “[Specifications](#)”) or to the accuracy that your application requires.

Current Limit Programming Circuit Calibration

To perform current limit programming circuit calibration:

1. Ensure that the power supply is turned OFF. Disconnect any load.
2. Connect the program source between J2 connector terminals 8 (output current limit programming input) and 7 (current program signal return).
3. Connect the shunt and DVM across the power supply output.
4. Turn the power supply ON.
5. Apply 1% of program voltage.
6. Adjust the current limit program offset (R469) until the shunt/DVM indicates 1% of the model-rated output current. See Note.
7. Apply 100% of program voltage.
8. Adjust the current limit program range (R459) until the shunt/DVM indicates the model-rated output current. See Note.

Repeat this procedure until output levels are adjusted to specifications (see “[Specifications](#)”) or to the accuracy that your application requires.

Important: Calculate the required DVM reading using $V = IR$ where V is the DVM reading, I is the current, and R is the DC shunt resistance.

Calibrating for Readback Accuracy

The factory calibrates the offset and range of the output voltage and current monitor circuits to within 1% for the default 0-10 Vdc scales. You may need to recalibrate when you select the 0-5 Vdc scale or when you switch back to the 0-10 Vdc scale after previously calibrating for 0-5 Vdc operation.

See “[Calibration Setup](#)” on page 5–2 for the procedures to remove the cover and any option card. Follow all procedure steps in the sequence given.

Output Voltage Monitor Circuit Calibration

To perform output voltage monitor circuit calibration:

1. Ensure that the power supply is turned OFF. Disconnect any load.
2. Set SW1 switch 5 OPEN to select 0-5 V output voltage monitor range, CLOSED for 0-10 V.
3. Connect a DVM across the power supply output to read the output voltage. Connect a second DVM between the rear panel J2 connector terminals 10 (output voltage monitor) and 9 (voltage monitor signal return).
4. Turn the power supply ON.
5. Set the power supply output voltage to 1% of the model-rated output.
6. Adjust the output voltage monitor offset (R397) until the monitor DVM reads 1% of the readback scale. (50 mVdc for 0-5 V readback or 100 mVdc for 0-10 Vdc readback.)
7. Set the power supply output voltage to the model-rated maximum.
8. Adjust the output voltage monitor range (R387) until the monitor DVM reads 100% of the readback scale. (5 Vdc for 0-5 V readback or 10 Vdc for 0-10 Vdc readback.)

Repeat this procedure until the monitor signal is adjusted to specifications (see “[Specifications](#)”) or to the accuracy that your application requires.

Output Current Monitor Circuit Calibration

To perform output current monitor circuit calibration:

1. Ensure that the power supply is turned OFF. Disconnect any load.
2. Set SW1 switch 6 OPEN to select 0-5 V output current monitor range, CLOSED for 0-10 V.
3. Connect the shunt and DVM across the power supply output to read the output current. Connect a second DVM between the rear panel J2 connector terminals 12 (output current monitor) and 11 (current monitor signal return).
4. Turn the current control fully counter-clockwise, then turn on the power supply.
5. Set the power supply's output current to 1% of the model-rated output. See Note.
6. Adjust the output current monitor offset (R394) until the monitor DVM indicates 1% of the readback scale. (50 mVdc for 0-5 V readback or 100 mVdc for 0-10 Vdc readback.)
7. Set the power supply output current to the model-rated output.
8. Adjust the output current monitor range (R383) until the monitor DVM indicates 100% of the readback scale. (5 Vdc for 0-5 V readback or 10 Vdc for 0-10 Vdc readback.)

Repeat this procedure until the monitor signal is adjusted to specifications (see “[Specifications](#)”) or to the accuracy that your application requires.

Important: Calculate the required DVM reading using $V = IR$ where V is the DVM reading, I is the current, and R is the DC shunt resistance.

User Diagnostics

If your power supply is not performing as described in this manual, run through the procedures and checks in this section before calling your service technician. These procedures are confined to operator level functions only and do not require cover-off servicing.

Emergency Shutdown

In an emergency, carry out both of these steps:

1. Shut the power supply OFF immediately.
2. Disconnect the power supply from the load.

Unusual or Erratic Operation

If the power supply displays any unusual or erratic operation, follow these steps:

1. Shut the power supply OFF immediately.
2. Disconnect the power supply from the load.
3. Test the power supply with no load, running the tests in [“Functional Tests” on page 2–10](#).
4. If the tests show that the power supply is functioning normally, check all load, programming, and monitoring connections and circuits.
5. Check the AC input for correct voltage and frequency.

If the problem is not solved after following this procedure, or if the unit fails to operate correctly upon retesting, call your service technician.

Turn to the next page for more information about troubleshooting for operators.

Troubleshooting for Operators

Use the checks in [Table 5-1](#) to ensure that the power supply is configured and connected for normal operation. If you need any further troubleshooting, call your service technician.

Abbreviated References Used in Table

ACF	AC Fail
OTP	over temperature protection
OVP	over voltage protection
REM	remote mode
S/D	shutdown

Table 5-1 User Diagnostics

Symptom	Check	Further Checks and Corrections
No output and the display is blank.	Is input voltage within specified range?	Connect to appropriate voltage source. See page 2-6 .
	Power switch ON?	Turn on power.
	Internal circuit?	See your service technician.
No output but the display turns on.	OVP LED turned on?	See page 3-7 .
	Front panel S/D LED turned on?	See page 3-9 .
	OTP LED turned on?	See page 3-16 .
	Current limit set to zero?	See page 3-6 .
	Voltage control set to zero?	See page 3-6 .
	REM LED turned on?	If using remote analog control, check your analog programming source (Chapter 4). If not, refer to your digital interface manual.
	Is front panel ACF LED turned on?	Connect unit to AC supply in specified range. See page 2-6 .
	Internal circuit.	See your service technician.

Table 5-1 User Diagnostics

Symptom	Check	Further Checks and Corrections
Output not adjustable.	Is unit in current limit mode? (Red Current Mode LED turned on.)	Turn current knob clockwise to increase current limit. Reduce load if current is at maximum. See page 3–6 .
	Is unit in remote mode? (Green REM LED turned on.)	If using remote analog control, check your analog programming source (Chapter 4). If not, refer to your digital interface manual.
	Is unit at maximum voltage or current limit?	Reduce load for lower voltage or current requirement.
Output voltage fluctuating or regulation poor.	Is unit at current limit?	Increase current limit setting or reduce load. See page 3–6 .
	Is input voltage within specified range?	Connect to appropriate AC voltage source. See page 2–6 .
	Are sense lines connected?	See page 2–10 and page 2–20 .
	Is unit under remote analog control?	Ensure program source is stable.
	Internal circuit.	See your service technician.
Output oscillating.	Internal circuit.	See your service technician.

A

Specifications

[Appendix A](#) contains electrical, mechanical and environmental specifications and characteristics of the XFR 1200 Watt Series Programmable DC Power Supply.

These specifications are warranted over a temperature range of 0 °C to 50 °C.

Nominal ambient temperature assumed is 25 °C.

Nominal line voltages are 120 Vac and 230 Vac.

See [Table A-1](#) and [Table A-2](#) for maximum values for model-dependent specifications.

Specifications are subject to change without notice.

Electrical Specifications

Table A-1 Electrical Specifications for 6 V to 35 V Models

Models	6-200	7.5-140	12-100	20-60	35-35
Output Ratings:					
Output Voltage ^a	0-6 V	0-7.5 V	0-12 V	0-20 V	0-35 V
Output Current ^b	0-200 A ^c	0-140 A	0-100 A	0-60 A	0-35 A
Output Power	1200 W	1050 W	1200 W	1200 W	1225 W
Line Regulation: ^d					
Voltage (0.01% of Vmax + 2 mV)	2.6 mV	2.75 mV	3.2 mV	4 mV	5.5 mV
Current (0.01% of Imax + 2 mA)	22 mA	16 mA	12 mA	8 mA	5.5 mA
Load Regulation: ^e					
Voltage (0.02% of Vmax + 5 mV)	8.2 mV	6.5 mV	7.4 mV	9 mV	12 mV
Current (0.02% of Imax + 5 mA)	45 mA	33 mA	25 mA	17 mA	12 mV
Meter Accuracy:					
Voltage (1% of Vmax + 1 count)	0.07 V	0.09 V	0.13 V	0.3 V	0.4 V
Current (1% of Imax + 1 count)	2.5 A	1.5 A	1.1 A	0.7 A	0.45 A
Output Noise (0-20 MHz):					
Voltage (p-p)	75 mV	75 mV	75 mV	75 mV	120 mV
Output Ripple (rms):					
Voltage	10 mV	10 mV	10 mV	10 mV	10 mV
Current ^f	750 mA	500 mA	500 mA	500 mA	300 mA
Drift (30 minutes): ^g					
Voltage (0.05% of Vmax)	3 mV	3.75 mV	6 mV	10 mV	17.5 mV
Current (0.8% of Imax)	2400 mA	1120 mA	800 mA	480 mA	280 mA
For Resistive Programming:					
Voltage (0.6% of Vmax)	36 mV	45 mV	72 mV	120 mV	210 mV
Current (0.6% of Imax)	2400 mA	840 mA	600 mA	360 mA	210 mA
Drift (8 hours): ^h					
Voltage (0.05% of Vmax)	3 mV	3.75 mV	6 mV	10 mV	17.5 mV
Current (0.05% of Imax)	200 mA	70 mA	50 mA	30 mA	17.5 mA
For Resistive Programming:					
Voltage (0.3% of Vmax)	18 mV	22 mV	36 mV	60 mV	105 mV
Current (0.3% of Imax)	600 mA	420 mA	300 mA	180 mA	105 mA

Table A-1 Electrical Specifications for 6 V to 35 V Models

Temperature Coefficient: ⁱ					
Voltage (0.02% of Vmax/°C)	1.2 mV	1.5 mV	2.4 mV	4 mV	7 mV
Current (0.03% of Imax/°C)	60 mA	42 mA	30 mA	18 mA	10.5 mA
For Resistive Programming:					
Voltage (0.06% of Vmax/°C)	3.6 mV	4.5 mV	7.2 mV	12 mV	21 mV
Current (0.06% of Imax/°C)	120 mA	84 mA	60 mA	36 mA	21 mA
OVP Adjustment Range: (5% to 110% of Vmax)	0.3-6.6 V	0.375-8.25 V	0.6-13.2 V	1-22 V	1.75-38.5 V
Efficiency: ^j	0.75	0.78	0.81	0.81	0.83

- a. Minimum output voltage is <0.15% of rated voltage at zero output setting.
- b. Minimum output current is <0.5% of model-rated current at zero output setting, when measured on minimum 10% of full power load.
- c. For rack mounted 6 V models, derate output current by 1.5 A per °C for operating temperatures between 30 °C and 50 °C. See “Environmental Specification” on page A-10.
- d. For input voltage variation over the AC input voltage range, with constant rated load.
- e. For 0-100% load variation, with constant nominal line voltage.
- f. Current mode noise is measured from 10% to 100% of rated output voltage, full current. For 6 V models, current noise is measured from 2 V to 6 V, full current.
- g. Maximum drift over 30 minutes with constant line, load, and temperature, after power on.
- h. Maximum drift over 8 hours with constant line, load, and temperature, after 30-minute warm-up.
- i. Change in output per °C change in ambient temperature, with constant line and load.
- j. Typical efficiency at 100 Vac input voltage and full output power.

Table A-2 Electrical Specifications for 40 V to 600 V Models

Models	40-30	60-20	100-12	150-8	300-4	600-2
Output Ratings:						
Output Voltage ^a	0-40 V	0-60 V	0-100 V	0-150 V	0-300 V	0-600 V
Output Current ^b	0-30 A	0-20 A	0-12 A	0-8 A	0-4 A	0-2 A
Output Power	1200 W	1200 W	1200 W	1200 W	1200 W	1200 W
Line Regulation: ^c						
Voltage (0.01% of Vmax + 2 mV)	6 mV	8 mV	12 mV	17 mV	32 mV	62 mV
Current (0.01% of Imax + 2 mA)	5 mA	4 mA	3.2 mA	2.8 mA	2.4 mA	2.2 mA
Load Regulation: ^d						
Voltage (0.02% of Vmax + 5 mV)	13 mV	17 mV	27 mV	35 mV	65 mV	125 mV
Current (0.02% of Imax + 5 mA)	11 mA	9 mA	7.4 mA	6.6 mA	5.8 mA	5.4 mA
Meter Accuracy:						
Voltage (1% of Vmax + 1 count)	0.5 V	0.7 V	1.1 V	1.6 V	4 V	7 V
Current (1% of Imax + 1 count)	0.4 A	0.3 A	0.13 A	0.09 A	0.05 A	0.03 A
Output Noise (0-20 MHz):						
Voltage (p-p)	150 mV	150 mV	150 mV	150 mV	200 mV	400 mV
Output Ripple (rms):						
Voltage	10 mV	10 mV	10 mV	20 mV	30 mV	80 mV
Current ^e	200 mA	100 mA	100 mA	50 mA	25 mA	15 mA
Drift (30 minutes): ^f						
Voltage (0.05% of Vmax)	20 mV	30 mV	50 mV	75 mV	150 mV	300 mV
Current (0.8% of Imax)	240 mA	160 mA	96 mA	64 mA	32 mA	16 mA
For Resistive Programming:						
Voltage (0.6% of Vmax)	240 mV	360 mV	600 mV	900 mV	1800 mV	3600 mV
Current (0.6% of Imax)	180 mA	120 mA	72 mA	48 mA	24 mA	12 mA
Drift (8 hours): ^g						
Voltage (0.05% of Vmax)	20 mV	30 mV	50 mV	75 mV	150 mV	300 mV
Current (0.05% of Imax)	15 mA	10 mA	6 mA	4 mA	2 mA	1 mA
For Resistive Programming:						
Voltage (0.3% of Vmax)	120 mV	180 mV	300 mV	450 mV	900 mV	1800 mV
Current (0.3% of Imax)	90 mA	60 mA	36 mA	24 mA	12 mA	6 mA

Table A-2 Electrical Specifications for 40 V to 600 V Models

Temperature Coefficient: ^h						
Voltage (0.02% of V _{max} /°C)	8 mV	12 mV	20 mV	30 mV	60 mV	120 mV
Current (0.03% of I _{max} /°C)	9 mA	6 mA	3.6 mA	2.4 mA	1.2 mA	0.6 mA
For Resistive Programming:						
Voltage (0.06% of V _{max} /°C)	24 mV	36 mV	60 mV	90 mV	180 mV	360 mV
Current (0.06% of I _{max} /°C)	18 mA	12 mA	7.2 mA	4.8 mA	4.2 mA	1.2 mA
OVP Adjustment Range: (5% to 110% of V _{max})	2-44 V	3-66 V	5-110 V	7.5-165 V	15-330 V	30-660 V
Efficiency: ⁱ	0.83	0.86	0.84	0.84	0.85	0.85

- a. Minimum output voltage is <0.15% of rated voltage at zero output setting.
- b. Minimum output current is <0.5% of model-rated current at zero output setting, when measured on minimum 10% of full power load.
- c. For input voltage variation over the AC input voltage range, with constant rated load.
- d. For 0-100% load variation, with constant nominal line voltage.
- e. Current mode noise is measured from 10% to 100% of rated output voltage, full current. For 6 V models, current noise is measured from 2 V to 6 V, full current.
- f. Maximum drift over 30 minutes with constant line, load, and temperature, after power on.
- g. Maximum drift over 8 hours with constant line, load, and temperature, after 30-minute warm-up.
- h. Change in output per °C change in ambient temperature, with constant line and load.
- i. Typical efficiency at 100 Vac input voltage and full output power.

Additional Specifications

Rise Time (No Load, Full Load): ^a	6 V to 60 V models: 100 ms; 100 V to 600 V models: 170 ms
Fall Time (No Load): ^a	6 V model: 1.5 s; 7.5 V to 60 V models: 3 s; 100 V to 600 V models: 4 s
Fall Time (Full Load): ^a	6 V model: 10 ms; 7.5 V to 60 V models: 100 ms; 100 V to 600 V models: 170 ms
Voltage Mode Transient Response: ^b	<3 ms
Time Delay from power on until output stable	7 s maximum

- a. Measured with stepped 0-10 V analog programming source and a resistive load.
- b. Time for the output voltage to recover within 0.5% of its rated value after a step change in load current of 10% to 90% of rated output with an output setpoint between 50-100% of rated value. Load slew rate <6 A/ms.

Input Conditions

Rated AC Input Voltage	100/120/200/220/230/240 Vac (nominal) $\pm 10\%$
Maximum AC Input Power	2600 VA
Operational AC Input Voltage	85-130 Vac or 190-264 Vac, 1 ϕ ; 6 V model: 95-130 Vac or 190-264 Vac, 1 ϕ . Auto range select function.
Maximum Input Current	20 A maximum at 120 Vac, 12 A maximum at 230 Vac.
Input Frequency Range	47-63 Hz
Power Factor	0.65 minimum at full load and 100 Vac input; 0.55 minimum at full load and 200 Vac input.

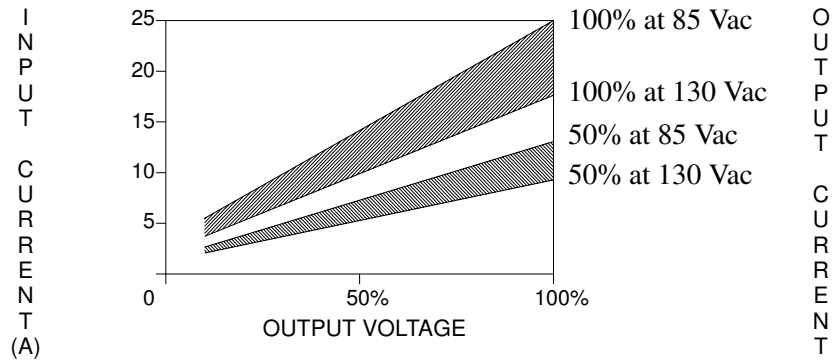

Figure A-1 Typical Input Current Characteristics, 85-130 Vac Range
(Based on 60 V, 20 A model)

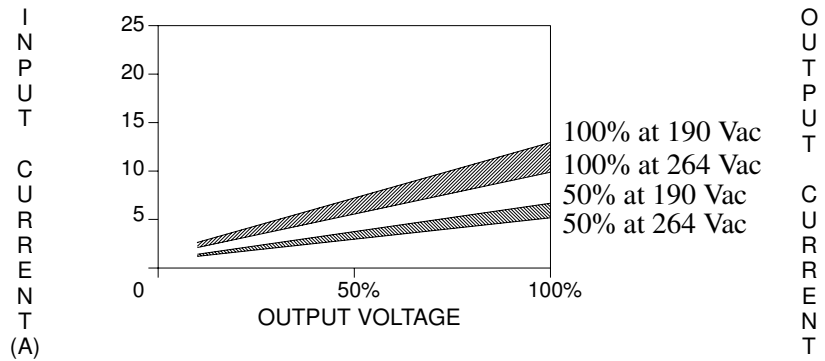

Figure A-2 Typical Input Current Characteristics, 190-264 Vac Range
(Based on 60 V, 20 A model)

Additional Features

Switching Frequency	6 V to 40 V models: nominal 78 kHz (156 kHz output ripple); 60 V to 600 V models: nominal 62.5 kHz (125 kHz output ripple).
Output Hold-up Time	Greater than 20 ms (6 V model: 16 ms) with interruption of AC line, for nominal AC input and full load.
Maximum Voltage Differential from either output to safety ground	± 600 Vdc
Insulation Resistance	Input to chassis: >30 M Ω , with 500 Vdc; ^a Output to chassis: >20 M Ω , with 1000 Vdc.
Isolation Voltage	Input to output: 1350 Vac

- a. To protect from power surges, the units have a 420 Vac varistor built in to act as an over-voltage clamp. The above insulation resistance specification is subject to be measured with the varistors taken out of the circuit

Remote Programming and Monitoring

Remote Start/Stop and Interlock	2.5-15 V signal or TTL-compatible input, selectable logic. TTL input impedance: 2 k (in series with one diode drop).
Remote Analog Programming (Full Scale Input)	Voltage and current programming inputs (source must be isolated): 0-5 k, 0-10 k resistances; 0-5 V, 0-10 V (default) voltage sources. Input impedance (V and I): approximately 100 k.
Remote Monitoring	Output voltage and current: 0-5 V, 0-10 V (default); Output impedance (V and I): approximately 221 Ω Output short circuit current: approximately 50 mA.
Remote Programming and Monitoring Accuracy	1% zero to full scale output for the default range.
Maximum Remote Sense Line Drop Compensation	5 V/line (Line drop is subtracted from total voltage available at supply output.)
Optional Isolated Program and Readback (V&I)	0-5 V (ISOL interface); input impedance: approx. 200 k; output impedance: low
Optional Digital Control	RS-232, GPIB interfaces

Environmental Specification

Operating Temperature Range 0 °C to 50 °C.
 6 V model: for rack mounted units, derate output current by 1.5 A per °C for operating temperatures between 30 °C and 50 °C. See [Figure A-3](#).

Storage Temperature Range	-20 °C to +70 °C
Humidity Range	up to 90% RH non-condensing
Operating Altitude	Up to 6,500 feet (2000 m)
Storage Altitude	Up to 50,000 feet (15 000 m)
Installation Category	II
Pollution Degree	2

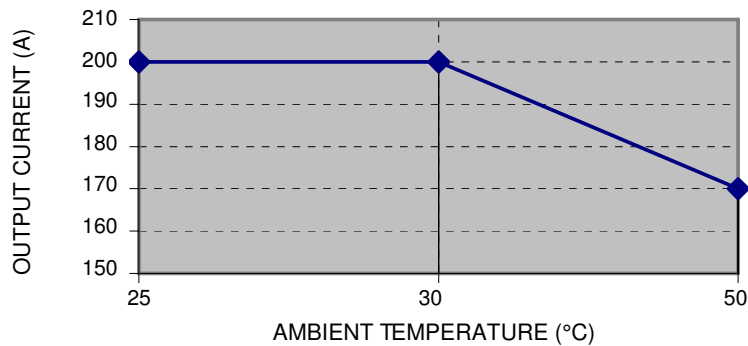

Figure A-3 Current Derating for Rack Mounted 6 V Models

Mechanical Specifications

Front Panel V and I Control	10-turn voltage and current potentiometers
Front Panel Voltage Control Resolution	0.02% of maximum voltage
Front Panel Voltage and Current Meters	3.5-digit green numeric LED displays. For accuracy specifications, see Table A-1 and Table A-2 .
AC Input Connector Type	3-terminal 34 A, 250 V, right angle, PC mount, wire clamp connector with removable strain relief cover
Input Fuses ^a	1 A, 250 V, 5 x 20 mm slow fuse (T), location: F34; 2 A, 250 V, 5 x 20 mm time delay (T), location: F95; 10 A, 250 Vac, 5 x 20 mm fast high interrupt (F), location: F29; 30 A, 300 Vac, 10.3 x 41.3 mm medium time lag (T), locations: F2, F4.
Output Connector	6 V to 40 V models: nickel-plated copper bus bars with removable bus bar shield; bus bar holes: 0.332 in. (8.17 mm) diameter (D) (1), 0.197 in. (5.0 mm) D (2); 60 V to 600 V models: 4-terminal wire clamp connector.
Sense Connector	5-terminal wire clamp connector (2 piece)
Analog Programming Connector	15-terminal wire clamp connector (2 piece)
Chassis Ground	Two chassis ground screws located on rear panel for bonding connections
Cooling	Fan cooled. Air exhausts to rear. Over temperature shutdown: automatic restart or latch off (switch-selectable).
Mounting	Rack mount ears integral to the front panel.
Weight	Approximately 18 lb. (8.2 kg)
Approvals	CE mark: Meets EMC standards EN50081-2 and EN50082-2 and safety standard IEC1010-1 c(UL)us: UL certified to UL3111-1, 1st edition and to CAN/CSA C22.2 No. 1010.1-92 FCC: Meets Class A limits of Part 15 subpart B

- a. Fuses are located on the A4 PCB (printed circuit board). The fuses are NOT operator-replaceable.

Specifications

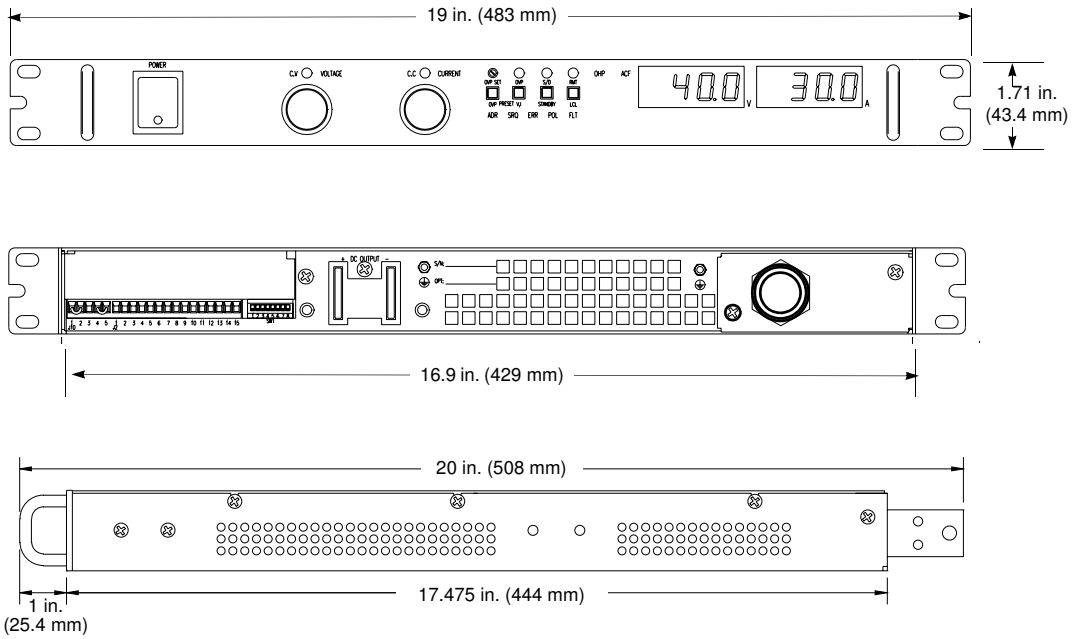

Figure A-4 Dimensional Drawings
(Dimensions given are nominal)