

# LC103

“ReZolver”™

## Capacitor & Inductor Analyzer

### Operation and Application Manual

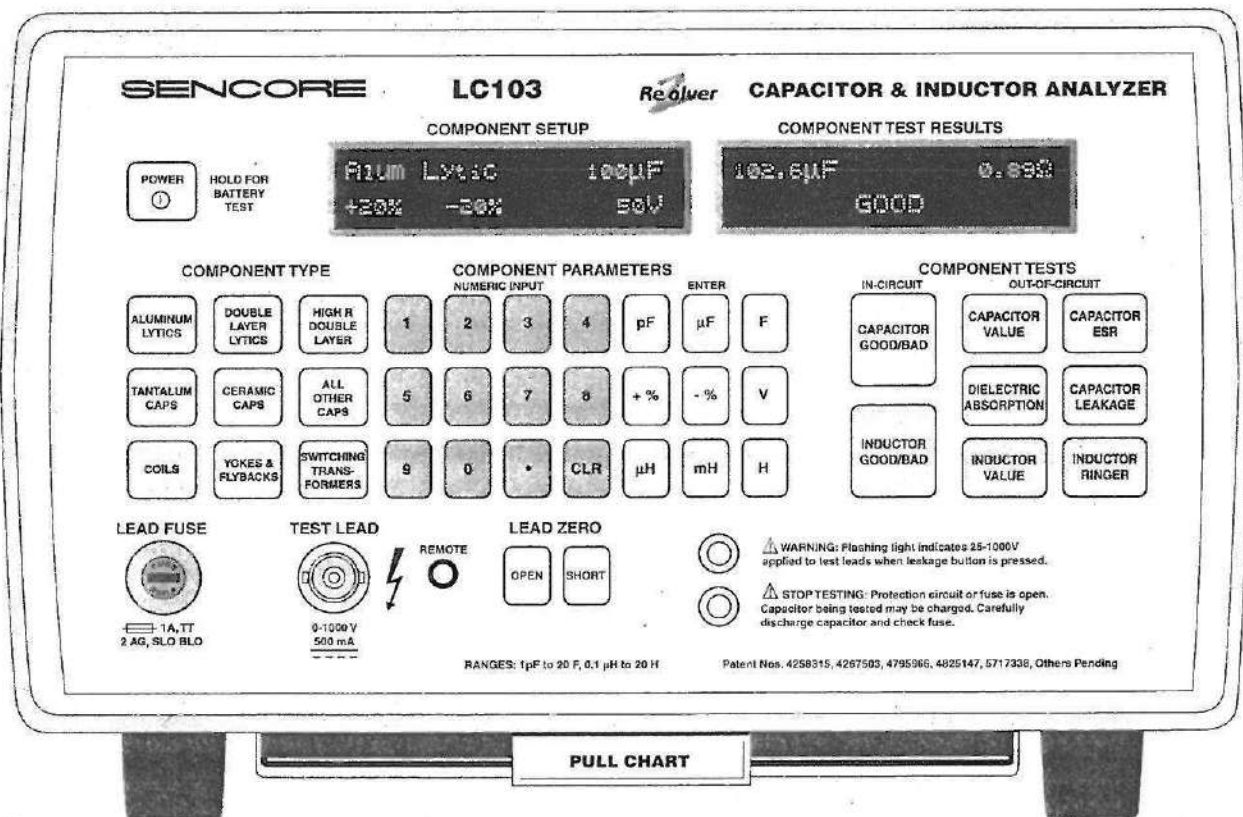

# SENCORE

3200 Sencore Drive, Sioux Falls, SD 57107

# WARNING

## PLEASE OBSERVE THESE SAFETY PRECAUTIONS

There is always a danger present when testing electronic equipment. Unexpected high voltages can be present at unusual locations in defective equipment. Every precaution has been taken in the design of your instrument to insure that it is as safe as possible. However, safe operation depends on you, the operator. Become familiar with the equipment you are working with, and observe the following safety precautions:

1. **Never exceed the limits of this instrument** as given in the specifications section and the additional special warnings in this manual.
2. **A severe shock hazard can result** if the chassis of the equipment being serviced is tied to the "hot" side of the AC line. An isolation transformer should always be used with hot-chassis equipment. Also, be sure that the top of your workbench and the floor underneath it are dry and made of non-conductive materials.
3. **Remove the circuit power before making connections** to high voltage points. If this cannot be done, be sure to avoid contact with other equipment or metal objects. Place one hand in your pocket and stand on an insulated floor to reduce the possibility of shock.
4. **Discharge filter capacitors** (after removing power) before connecting to any part of the circuit requiring power to be removed.
5. **Be sure your equipment is in good order.** Broken or frayed test leads can be extremely dangerous and can expose you to dangerous voltages.
6. **Remove the test lead immediately** after the test has been completed to reduce the possibility of shock.
7. **Do not work alone when working on hazardous circuits.** Always have another person close by in case of an accident. Remember, even a minor shock can be the cause of a more serious accident, such as falling against the equipment, or coming in contact with high voltages.
8. **Improper Fuse(s) Void Warranty.** Fuses are for your protection, so always replace fuse with proper type and current rating. The proper fuse type description is marked near the fuse holder and in the manual. Always:
  - A. **Be sure you are replacing the right fuse.** On units with more than one fuse, be sure you are placing the proper fuse value in the fuse holder.
  - B. **Have the proper size replacement fuse in stock.** With each new instrument, be sure to update your fuse inventory with any special value fuses your instrument may require.
9. **Explanation of symbols.**



This marking indicates that the operator must refer to an explanation in the operating instructions.



A terminal at which a voltage with respect to another terminal or part exists or may be adjusted to 1,000 volts or more.



# LC103

## “ReZolver”

### Capacitor & Inductor Analyzer

#### Operation and Application Manual

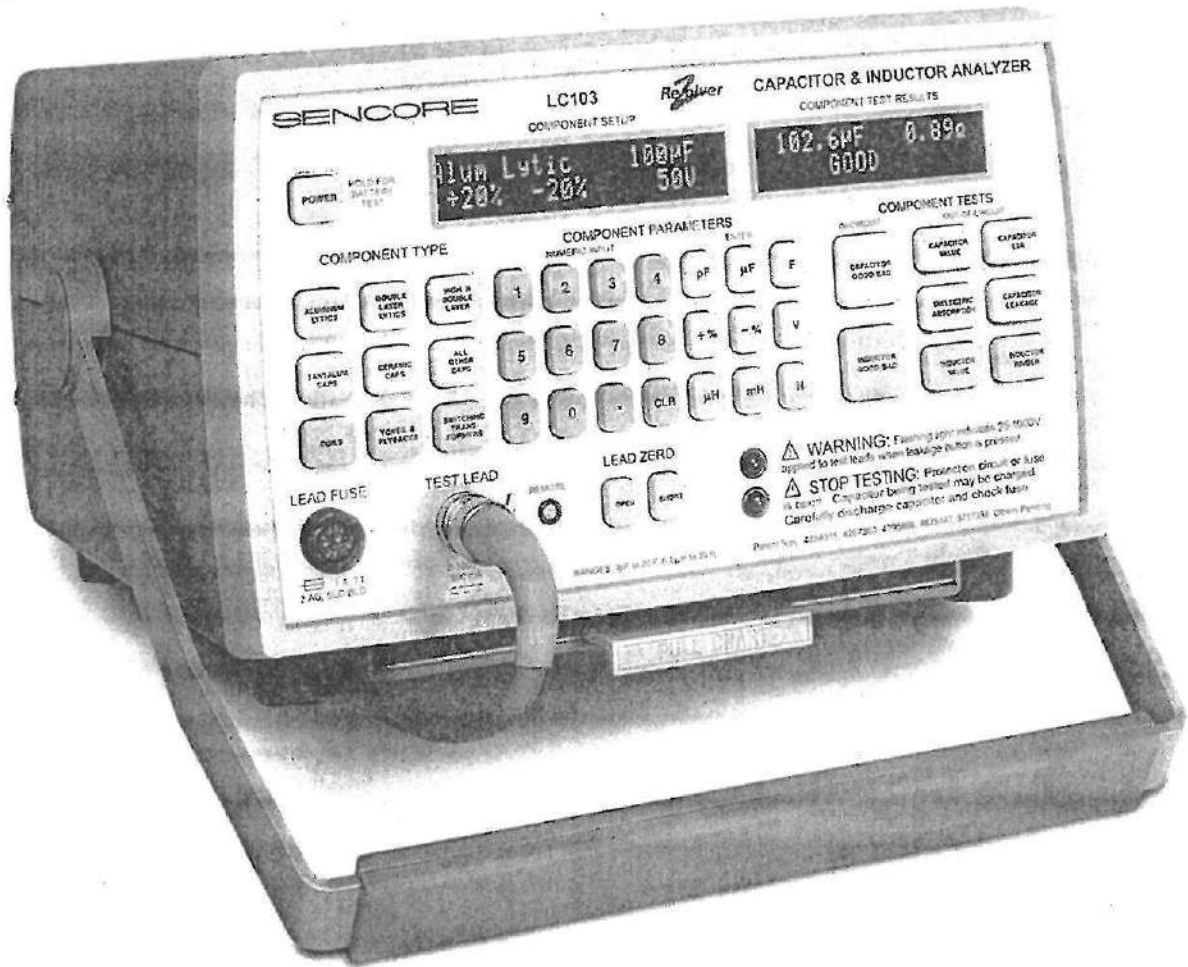

# SENCORE

3200 Sencore Drive • Sioux Falls, SD 57107

# TABLE OF CONTENTS

**SAFETY PRECAUTIONS** .....Inside Front Cover

## DESCRIPTION

Introduction .....	4
Features .....	4
Specifications .....	5
Front Panel Controls .....	7
Rear Panel Features .....	8
Supplied Accessories .....	8
Optional Accessories .....	9

## OPERATION

Introduction .....	10
AC Power Operation .....	10
Battery Operation .....	11
Battery Test.....	12
Recharging the Battery .....	12
Auto-Off .....	12

<b>STOP TESTING</b> Indication.....	13
Test Lead Fuse .....	13

<b>Test Leads</b> .....	13
Adjustable In- Circuit Test Probe .....	13
Test Lead Mounting Clip .....	14
Lead and Probe Zeroing .....	14

<b>Entering Component Data</b> .....	15
Component Type .....	15
Component Value .....	15
Tolerance .....	15
Leakage Voltage.....	16

<b>In-Circuit Capacitor Testing</b> .....	17
Value and ESR Testing .....	17
Automatic EIA GOOD/BAD Testing .....	17
SUGGEST REMOVAL Indication.....	17

<b>Out-of-Circuit Capacitor Testing</b> .....	18
---	----

<b>Out-of-Circuit Capacitor Parameter Testing</b> .....	18
Component Test Results .....	18
Measuring Capacitor Value.....	18
Measuring Capacitor ESR .....	18
Measuring Capacitor D/A.....	19
Measuring Capacitor Leakage .....	20
Leakage In Paper, Mica and Film Capacitors .....	21
Leakage In Ceramic Capacitors .....	21
Leakage In Aluminum Electrolysis .....	21
Leakage In Tantalum Electrolysis .....	21
Leakage In Non-Polarized (Bi-Polar) Electrolytics.....	21
Leakage Charts .....	22

<b>Automatic GOOD/BAD Capacitor Testing</b> .....	24
<b>In-Circuit Inductor Testing</b> .....	25
<b>Out-of-Circuit Inductor Testing</b> .....	25

Measuring Inductor Value .....	25
Automatic GOOD/BAD Inductor Value Testing .....	26
Inductor Ringer Test.....	26

<b>Error Messages</b> .....	27
-----------------------------	----

<b>RS-232 OPERATION</b> .....	28
-------------------------------	----

<b>Connecting To The Computer</b> .....	28
---	----

<b>Sending Data To The LC103</b> .....	28
--	----

Component Type Commands .....	29
Value Multipliers.....	29
Setting The Leakage Voltage .....	30
Test Function Commands .....	30
General Codes.....	30

<b>Receiving Data From The LC103</b> .....	31
--	----

Data Format.....	31
Error Testing.....	32
Shorted Capacitors .....	32
Open Inductors.....	32
Making Leakage Tests .....	32
Making ESR Tests .....	33

## APPLICATIONS

<b>Introduction</b> .....	34
---------------------------	----

<b>Identifying Capacitor Types</b> .....	34
--	----

Aluminum Electrolytics .....	35
Tantalum Electrolytics.....	35
Double Layer and "High R" Electrolytics.....	36
Ceramic Capacitors .....	36
Other Capacitor Types .....	36

<b>Identifying Inductor Types</b> .....	37
---	----

Yokes and Flybacks.....	37
Switching Transformers .....	37
Coils .....	37

<b>Identifying Unknown Components</b> .....	38
---	----

<b>Capacitor Testing</b> .....	38
--------------------------------	----

Capacitance Measurement Accuracy .....	38
Measuring Small Capacitance Values	
In Noisy Environments .....	38
Interpreting Capacitor Value Readings .....	39
In-Circuit Capacitor Test.....	39
Testing Non-Polarized (Bi-Polar) Electrolytics .....	40
Checking Leakage in a Multi-Section Electrolytic ....	40
Dielectric Stress .....	40
Intermittent Capacitors .....	40
Checking Ceramic Capacitor	
Temperature Characteristics.....	40

<b>Inductor Testing</b> .....	41
-------------------------------	----

In-Circuit Inductor Test .....	41
Mutual Inductance .....	41
Ringing Peaking Coils .....	41
Ringing Metal Shielded Coils .....	41



Testing Flyback Transformers and Deflection Yokes .....	41
Ringing Flyback Transformers .....	41
Leakage Testing Flyback Transformers .....	42
Ringing Deflection Yokes .....	43
<b>Transmission Cable Testing</b> .....	43
Testing Coaxial Cable .....	43
Determining a Cable's Length or Distance To An Open .....	44
Locating A Short In Coaxial Cable .....	44
Determining Capacitance and Inductance Per Foot .....	45
Identifying Aging Cable.....	45
<b>Testing High Voltage Diodes</b> .....	46
<b>High Potential Testing</b> .....	46
<b>Measuring High Voltage Resistors to 1 Gigohm</b> .....	47
 <b>APPENDIX</b>	
<b>Introduction</b> .....	48
<b>Capacitor Theory</b> .....	48
<b>Capacitor Types</b> .....	49
Aluminum Electrolytics .....	49
Tantalum Electrolytics.....	49
Ceramics .....	49
<b>Capacitor Failure Modes</b> .....	51
Value Change .....	51
ESR .....	51
D/A.....	52
Leakage.....	52
 <b>GLOSSARY</b> .....	57
 <b>WARRANTY AND SERVICE</b> .....	Inside Back Cover

# DESCRIPTION

## INTRODUCTION

---

Capacitors and inductors are widely used in electronic systems. Capacitor and inductor usage continues to increase since neither of these components can be physically incorporated into ICs on a broad basis. Though capacitors and inductors have changed in physical size, they still perform the same basic functions. In today's high tech electronic circuits, capacitors and inductors are critical to normal circuit operation.

In today's high performance circuits, value, leakage, dielectric absorption, and ESR are important indicators of a capacitor's ability to perform properly in-circuit. Inductors too, must be of proper value and quality. Unless all of these parameters are thoroughly analyzed, problem capacitors and inductors may be missed and troubleshooting becomes a guessing game.

The Sencore LC103 ReZolver takes the guesswork out of capacitor and inductor testing. It provides in-circuit capacitor value and ESR tests along with automatic out-of-circuit tests for capacitor value, leakage, ESR, and dielectric absorption. Inductors are automatically analyzed in-circuit for value or out-of-circuit for value and quality with patented tests.

The LC103 is a complete, automatic, microprocessor-controlled capacitor and inductor analyzer. Its features make it ideally suited for both single component analyzing in service or maintenance work, or for large volume, batch testing in a lab or incoming inspection.

## FEATURES

---

The Sencore LC103 ReZolver is a dynamic, portable, automatic, in or out-of-circuit capacitor and inductor analyzer. It is designed to quickly identify defective capacitors and inductors by providing fast in-circuit tests and complete analyzing out-of-circuit. The test results are displayed on an easy-to-read fluorescent display in common terms. All capacitor and inductor test results may also be displayed as GOOD/BAD compared to standards adopted by the Electronic Industries Association (EIA).

In addition to testing capacitors for value up to 20 Farads, the LC103 checks capacitors for leakage at their rated working voltage, up to 1000 Volts. ESR is checked with a patented test, and an automatic, patented test checks for excessive dielectric absorption. A patented inductance value test provides a fast, accurate test of true inductance. A patented ringing test checks coils, deflection yokes, switching power supply transformers, and other non-iron core inductors with a fast, reliable GOOD/BAD test.

Automatic lead zeroing balances out test lead capacitance, resistance, and inductance for accurate test results. The LC103 is protected from external voltages applied to the test leads by a fuse located on the front panel. Stop-testing circuitry locks out all test buttons when voltage is sensed on the test leads.

Battery operation makes the LC103 completely portable for on-location troubleshooting in all types of servicing including industrial equipment, avionics, and cable fault locating. An optional SCR250 SCR & TRIAC TEST ACCESSORY extends the LC103 test capabilities to provide a fast, accurate test of these components. The LC103 may be used with an RS-232 computer interface for fully automatic, computer controlled testing in a laboratory or incoming inspection area.



# SPECIFICATIONS

## IN-CIRCUIT TESTS (Capacitors and Inductors)

Dynamic in-circuit tests to determine whether the capacitor or inductor is good or bad.

COMPONENT TYPES: Electrolytic, double layer lytic, tantalum, ceramic, and other capacitors. Yokes, flybacks, switching transformers, and coils.

RANGE: INDUCTORS - 3.18 uH to 3.18 H

CAPACITORS:

VALUE: 0.002 uF - 20,000 uF

ESR: 0.02 uF - 20,000 uF

ACCURACY: Same as Out-of-Circuit tests for known good inductors and capacitors with no parallel components.

## CAPACITORS (Out-of-circuit)

### VALUE

Dynamic test of capacity value is determined by applying a constant current to the capacitor and measuring the  $dV/dt$ :

10 uA	1.0 pF to 0.2 uF
100 uA	0.2uF to 2 uF
60 mA	2.0 uF to 2,000 uF
416 mA	2,000 uF to 20,000 uF

capacitors from 20,000 uF to 20 F are pulsed with 100 mA

ACCURACY: +/- 1%; +/- 1 pF; +/- 1 digit for values to 1990 uF; +/- 5%; +/- 0.1% of range full scale for values 2000 uF to 19.99 F.

RESOLUTION AND RANGES: 1.0 pF to 19.99 F, fully autoranged

0.1 pF	1.0 pF to 199.9 pF
1.0 pF	200 pF to 1999 pF
0.00001 uF	0.002 uF to 0.01999uF
0.0001 uF	0.02 uF to 0.1999 uF
0.001 uF	0.2 uF to 1.999 uF
0.01 uF	2.0uF to 19.99 uF
0.1 uF	20.0 uF to 199.9 uF
1.0 uF	200 uF to 1,999 uF
10 uF	2,000 uF to 19,990 uF
100 uF	20,000 uF to 199,900 uF
0.001 F	0.2 F to 1.999 F
0.01 F	2.0 F to 19.99 F

### LEAKAGE

ACCURACY: +/- 5%; +/- 1 digit

APPLIED VOLTAGE: Keyboard entry; 1.0 to 1000 volts in 0.1 volt steps; accuracy +0% -5%. Short circuit current limited to 900 mA, power limited to 9 Watts.

RESOLUTION AND RANGES: 0.01 uA to 20 mA, fully autoranged

0.01 uA	0.01 uA to 19.99 uA
0.1 uA	20.0 uA to 199.9 uA
1.0 uA	200 uA to 1999 uA
0.01 mA	2.00 mA to 19.99 mA

## EQUIVALENT SERIES RESISTANCE (ESR)

(U.S Patent #4,795,966)

ACCURACY: +/-5%; +/-1 digit

CAPACITOR RANGE: 0.01 uF to 19.99 F

RESOLUTION AND RANGES: 0.1 ohm to 1999 ohms, fully autoranged for capacitor values greater than or equal to 1 uF

0.01 ohm	0.1 ohm to 1.99 ohms
0.1ohm	2.0 ohms to 19.9 ohms
1 ohm	20 ohms to 1999 ohms

for capacitor values less than 1 uF 1ohm 1ohm to 1999 ohms

## DIELECTRIC ABSORPTION (U.S. Patent #4,267,503)

ACCURACY: +/- 5% of reading +/- 1 count

RANGE: 1 to 100%

CAPACITOR RANGE: 0.01 uF to 19.99 F

## INDUCTORS (Out-of-Circuit)

VALUE (U.S. Patent #4,258,315)

A dynamic test of value determined by measuring the EMF produced when a changing current is applied to the coil under test.

CURRENT RATES: automatically selected

19.5 mA/uSec	0.1 uH to 18 uH
1.95 mA/uSec	18 uH to 180 uH
0.195 mA/uSec	180 uH to 1.8 mH
19.5 mA/mSec	1.8 mH to 18 mH
1.95 mA/mSec	18 mH to 180 mH
0.195 mA/mSec	180 mH to 1.8 H
17.5 mA/Sec	1.8 H to 19.99 H

ACCURACY: +/-2%; +/-1 digit +/-0.1 uH

RESOLUTION AND RANGES: 0.10 uH to 20 H, fully autoranged

0.01 uH	0.1 uH to 19.99 uH
0.1uH	20.0 uH to 199.9 uH
1.0 uH	200 uH to 999 uH
0.001 mH	1.000 mH to 1.999 mH
0.01 mH	2.00 mH to 19.99 mH
0.1 mH	20.0 mH to 199.9 mH
1 mH	200 mH to 999 mH
0.001 H	1.000 H to 1.999 H
0.01 H	2.00 H to 19.99 H

## RINGING TEST (U.S. Patent #3,990,002)

A dynamic test of inductor quality determined by applying an exciting pulse to the inductor and counting the number of cycles the inductor rings before reaching a preset damping point.

INDUCTOR RANGE: 10 uH and larger, non-iron core  
ACCURACY: +/- 1 count on readings between 8 and 13

Rings

RESOLUTION: +/- 1 count

EXCITING PULSE: 5 volts peak

## SPECIFICATIONS CONTINUED

---

### DISPLAY

#### COMPONENT TEST RESULTS

TYPE: 2 x 17 Alphanumeric Vacuum Fluorescent

READINGS: Fully autoranged with auto decimal placement. One or two place holding zeros added as needed to provide standard value readouts of pF, uF, uH, or mH.

#### COMPONENT SETUP

TYPE: 2 x 20 Alphanumeric Vacuum Fluorescent

READINGS: All component types, component value, tolerance, and voltage rating.

### GENERAL

TEMPERATURE: operating range: 32° to 104° F (0° to 40° C) range for specified accuracy (after 10 minute warm-up): 50° to 86° F (10° to 30° C)

HUMIDITY: 0-90%, no condensation

MAXIMUM ALTITUDE: 4,000 meters

POWER: 105-130V AC, 60Hz, 30 watts with supplied PA251 power adapter. Battery operation with optional BY289 rechargeable battery. 210-230V AC operation with optional PA252 Power Adapter.

AUTO-OFF: Removes power during battery operation if unit sits idle longer than 5 minutes.

BATTERY LIFE: 2 hours for typical operation.

SIZE: 6" x 9" x 11.5" (15.2 cm x 22.9 cm x 29.1 cm) HWD

WEIGHT: 6.0 lbs. (2.7 kg) without battery, 7.6 lbs. (3.4 kg) with battery

GOOD/BAD INDICATION: Functions on all tests.

Requires user input of component type and value, or input of desired limits.

*Specifications subject to change without notice*



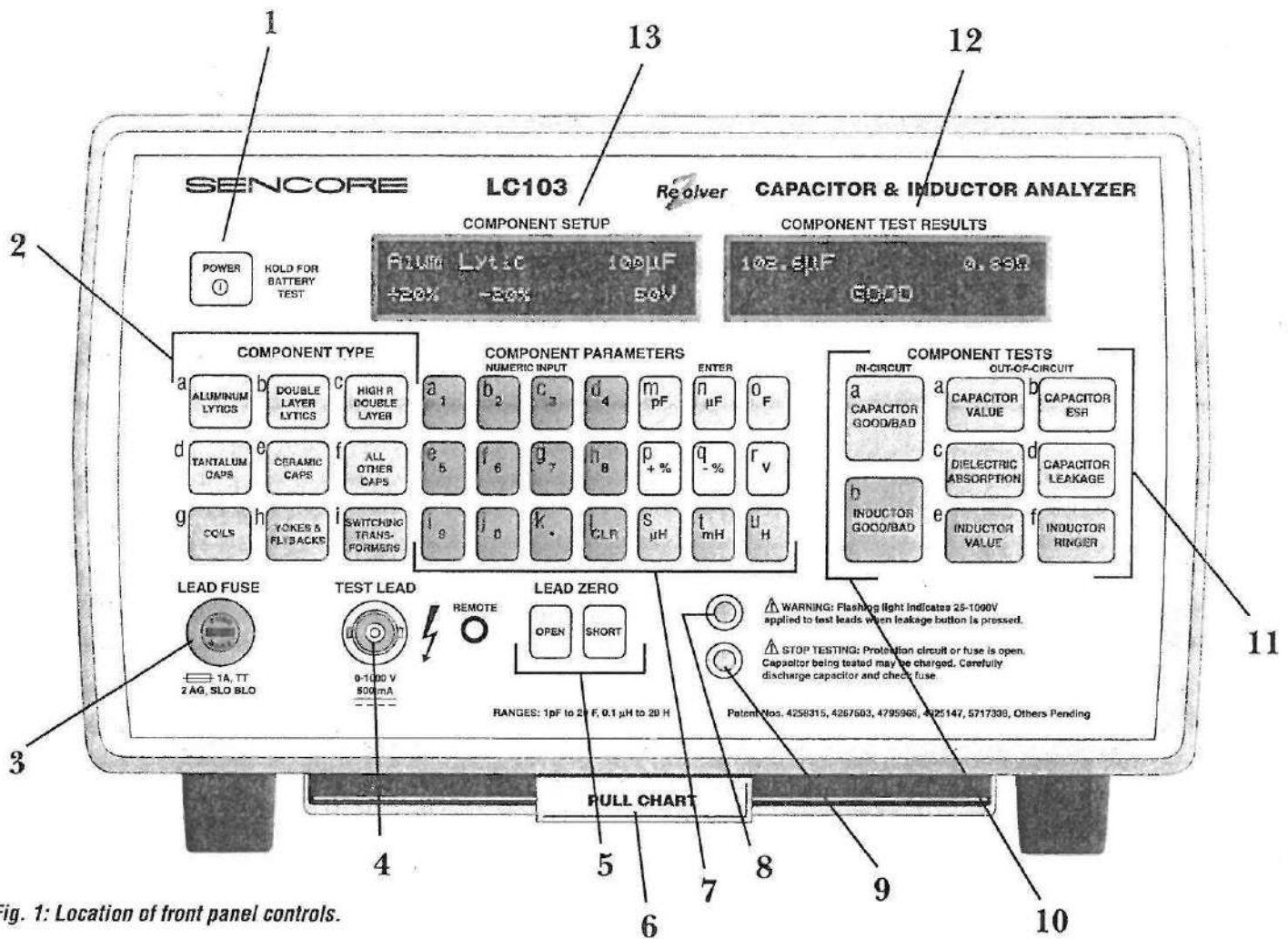

Fig. 1: Location of front panel controls.

## FRONT PANEL CONTROLS

1. **POWER Button** - Press to power unit on or off. Press and hold for Battery Test.
2. **COMPONENT TYPE Buttons** - Use to select component type to be tested.
  - a-f Press to select desired capacitor type
  - g-i Press to select desired inductor type
3. **LEAD FUSE** - Unscrew for access to the test lead fuse.
4. **TEST LEAD Jack** - BNC type jack to connect test leads to unit.
5. **LEAD ZERO Buttons** - Use to compensate for test lead impedance.
  - a. **OPEN** - Press to compensate for test lead capacitance with test leads open.
  - b. **SHORT** - Press to compensate for test lead inductance and resistance with test leads shorted.
6. **PULL CHART** - Provides simplified operating instructions and quick reference tables.
7. **COMPONENT PARAMETERS Buttons** - Use to enter component parameters for limit testing.
  - a-k Use to enter numerical portion of parameters.
  - l. **CLR** - Press once to clear numeric input. Press twice to clear all component parameters.
  - m-o Capacitor Value Multipliers: Use after numeric input to enter capacitor value.
  - p-q Percentage buttons: Use after numeric input to enter component tolerance.
  - r. Volts: Use after numeric input to enter voltage for capacitor leakage test.
- s-u Inductor Value Multipliers: Use after numeric input to enter inductor value.
8. **WARNING LED** - Flashes to indicate leakage voltage has been set to 25 volts or more. Voltage is only present when CAPACITOR LEAKAGE button is pressed.
9. **STOP TESTING LED** - Flashes along with an audible alarm and "FUSE OPEN" message to indicate test lead fuse is open.
10. **IN-CIRCUIT Test Buttons** - Press to test capacitors or inductors in-circuit.
11. **OUT-OF-CIRCUIT Test Buttons**
  - a. **Capacitor GOOD/BAD** - Press to measure capacitor value and ESR in-circuit.
  - b. **Inductor GOOD/BAD** - Press to measure inductance value in-circuit.
  - c. **Dielectric Absorption** - Press to measure percentage of dielectric absorption.
  - d. **Capacitor Leakage** - Press to measure the amount of leakage after a voltage has been entered with the COMPONENT PARAMETERS keypad (6).
  - e. **Inductor Value** - Press to measure inductance value.
  - f. **Inductor Ringer** - Press to activate Ringer test after selecting inductor type (2g-i).
12. **COMPONENT TEST RESULTS Display** - Displays the resultant value of test.
13. **COMPONENT SETUP Display** - Displays entered component type, value, tolerance, and voltage rating.

## REAR PANEL FEATURES

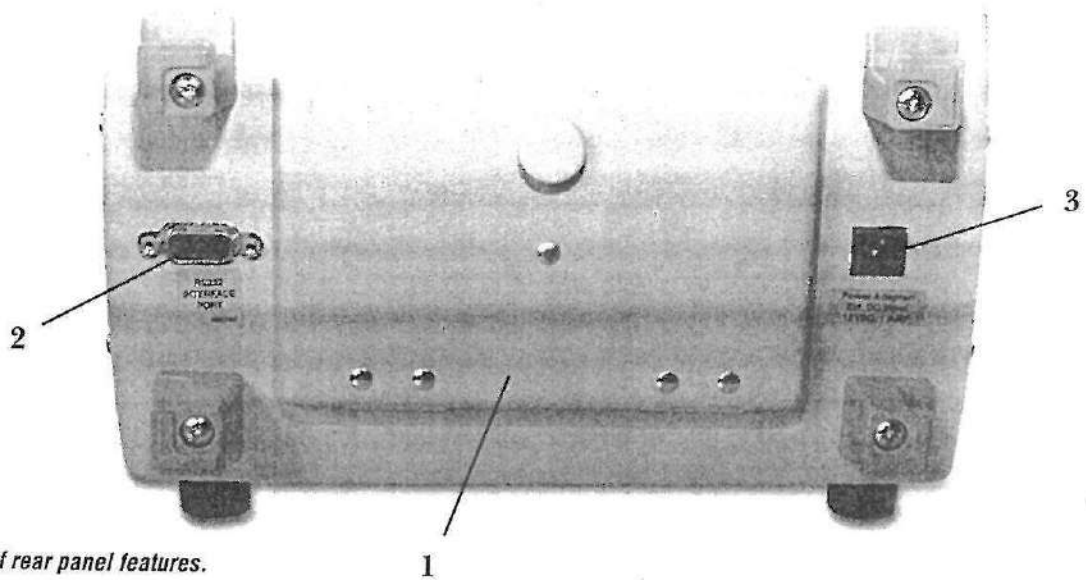

Fig. 2: Location of rear panel features.

1. **BATTERY COMPARTMENT COVER** - Provides access to the (optional) BY289 rechargeable battery.
2. **RS-232 SERIAL CONNECTOR** - Allows connection to a computer for automated operation.
3. **POWER ADAPTER Jack** - Connects to supplied PA251 POWER ADAPTER for 110 VAC operation, or to (optional) PA252 for 220 VAC operation.

## SUPPLIED ACCESSORIES

1. **Out-of-Circuit Test Leads (39G219)** - Special low capacity cable with E-Z Hook® clips. Connect to TEST LEAD jack.
2. **Adjustable In-Circuit Test Probe (AP291) patent pending** - Exclusive in-circuit probe with width adjustment wheel and test activation switch. Connect to TEST LEAD jack.
3. **Test Lead Mounting Clip (64G37)** - Use to hold test leads when not in use.
4. **Power Adapter/Charger (PA251)** - Plugs into POWER INPUT to power unit from 105-130 VAC line. Also recharges the (optional) BY289 battery when installed inside the LC103.

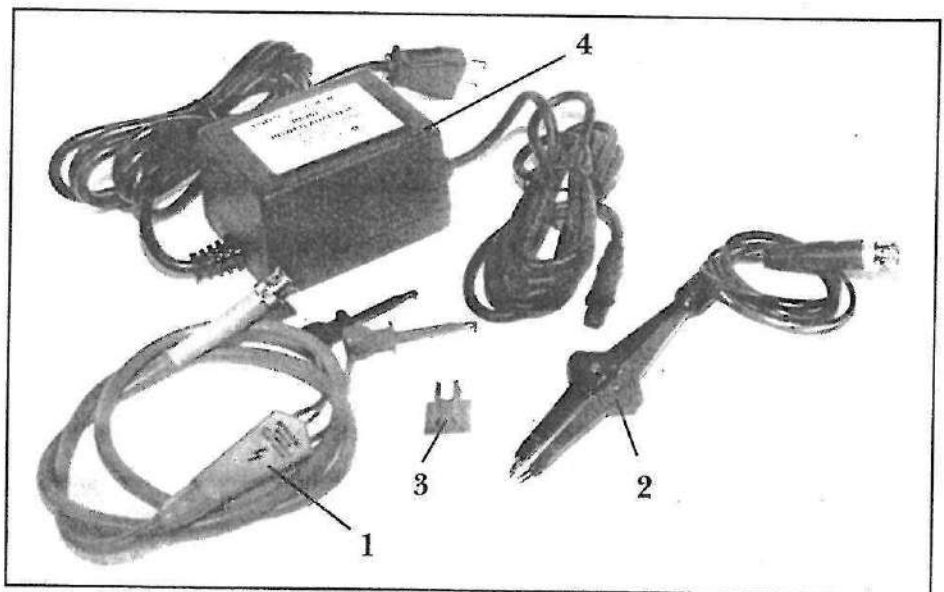

Fig. 3: Supplied Accessories



## OPTIONAL ACCESSORIES

1. **Test Lead Adapter (39GI44)** – Use to adapt Out-Of-Circuit Test Leads to large, screw terminal capacitors.
2. **220 VAC Power Adapter/Charger (PA252)** – Plugs into POWER INPUT to power the unit from 210-230 VAC line. Also recharges the (optional) BY289 battery when installed inside the LC103.
3. **Touch Test Probe (39G85)** – Use for Hi-Pot testing of circuit board traces.
4. **Field Calibrator (FC221)** – Use to periodically check the calibration of the LC103.
5. **Rechargeable Battery (BY289)** – Lead acid battery provides portable operation for the LC103.
6. **SCR/TRIAC Test Accessory (SCR250)** – Use to test SCRs and TRIACs.
7. **Carrying Case (CC254)** – Provides protection and easy carrying for the LC103 and its accessories.
8. **Component Holder (CH255)** – Use to hold components for fast tests when doing volume testing.
9. **Chip Component Test Lead (CH256)** – Special shielded test leads for testing small surface mount (chip) components out-of-circuit.

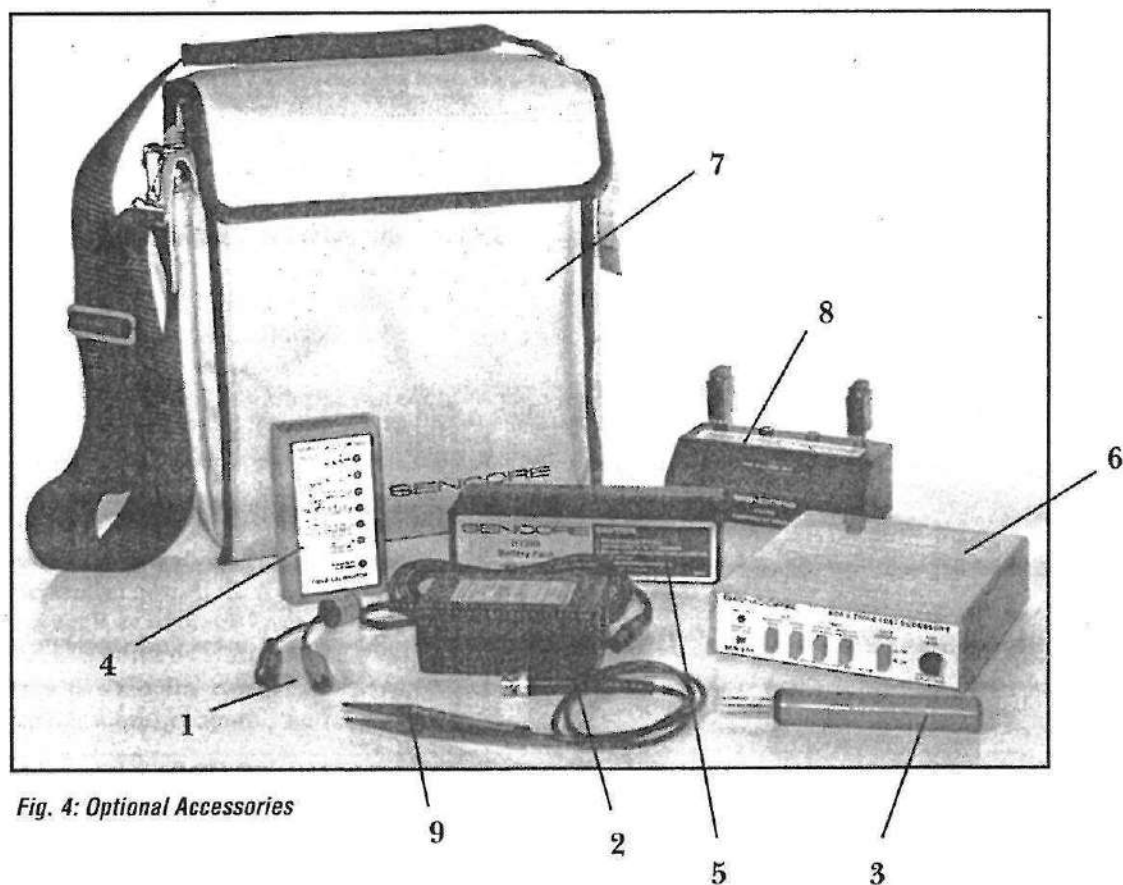

Fig. 4: Optional Accessories

# OPERATION

## INTRODUCTION

Before you begin to use the LC103 ReZolver, take a few minutes to read this section and the Applications sections of this manual to become familiar with the features and

capabilities of your instrument. After you have familiarized yourself with the general operation of the LC103, most tests can be performed with the information on the front panel

## AC POWER OPERATION

For continuous bench operation, the LC103 is powered from any standard 105-130 V (50-60 Hz) AC line using the PA251 Power Adapter. When 220 VAC operation is required, power the LC103 with the optional PA252 220 VAC Power Adapter. Connect the Power Adapter to the POWER IN jack located on the rear panel of the LC103.

The power adapter serves as a battery charger to recharge the (optional) BY289 battery when it is installed in the unit. The BY289 may be left installed in the LC103 at all times without danger of over charging. Connecting the Power Adapter bypasses the auto-off circuitry in the LC103 and allows uninterrupted operation.

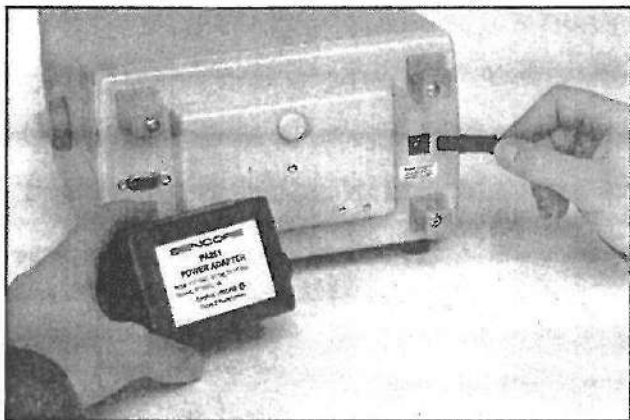

Fig. 5: Connect the PA251 to the 12 VDC input for AC bench operation and to recharge the optional battery.

### WARNING

Only use a Sencore PA251 or PA252 Power Adapter for AC operation. Using an AC adapter other than the PA251 or PA252 may cause damage to the LC103, may cause the optional battery (if installed) to improperly charge, or may cause measurement errors on low value components.

### ATTENTION

Utilisez seulement le PA251 ou PA252 de Sencore comme adaptateur secteur. L'utilisation d'un adaptateur secteur pour le LC103 différent du PA251 ou du PA252 peut endommager l'appareil, peut empêcher la batterie (si installée) de se charger correctement et peut altérer les mesures en affichant des résultats bas.

### To operate the LC103 from an AC line:

1. Connect the AC line cord of the power adapter to an adequate source of AC power.
2. Connect the power adapter to the POWER INPUT JACK on the back of the LC103, as shown in Figure 5.
3. Push the POWER button on the LC103 and release. The WARNING LED should momentarily blink to indicate the unit is operational and the displays will reset and read "LC103 ReZolver" - "Ready."
4. The LC103 is now ready for use. If precise measurements are required, allow the unit to operate for 20 minutes to reach specified accuracy.

### WARNING

The STOP TESTING indicator LED should momentarily blink when the POWER button is first pressed turning the LC103 on. Failure of the light to flash indicates a problem with the LED or safety circuits. DO NOT operate the LC103 in this condition, since it may expose the operator to dangerous voltages without adequate warning.

### ATTENTION

La LED d'indication d'erreur doit clignoter pour quelques instants lorsque le bouton de marche/arrêt est utilisé pour la mise en marche du LC103. Si cette LED ne clignote pas, cela indique un problème avec la LED ou le circuit de sécurité. NE PAS utiliser le LC103 dans ces conditions, car l'utilisateur peut être exposé à des voltages élevés sans le savoir.



## BATTERY OPERATION

The LC103 is designed to operate as a completely portable unit with the optional BY289 rechargeable battery installed. The operation of the LC103 when it is battery powered is the same as when it is AC powered except that the display will dim slightly to reduce the power consumption and increase battery life. The length of time the LC103 will operate before the battery needs recharging depends on several factors: 1. the test functions used; 2. temperature; 3. battery age.

Leakage tests place the heaviest current drain on the battery — greater currents result in shorter battery life between charging. Value tests place the least drain on the battery. The LC103 provides approximately 2 hours of typical operation using battery power. These times, of course, will vary with temperature and battery age.

As the temperature of the battery decreases, its capacity also decreases. The operating time between recharging decreases at the rate of approximately 1 hour for every 20° F drop in temperature below 70° F. The BY289 battery is a sealed, lead acid type that requires no maintenance other than recharging. As a battery ages, it will require more frequent recharging. If used properly, the BY289 will provide several years of service before needing replacement.

**You can maximize the lifetime of the BY289 several ways:**

1. Never allow the battery to deeply discharge. The LC103 has a built-in battery test and low battery shut off circuitry. Check the remaining charge periodically and recharge the battery before the low battery circuit shuts the unit off.
2. Keep the battery fully charged. The BY289 will not be harmed if it is left installed in the LC103 during AC operation. Instead, this will keep the battery fresh and ready for use and will actually lengthen its useful lifetime.
3. Recharge the battery before using it if it has sat idle for more than a couple of weeks. Lead acid batteries may lose some of their charge if they sit idle for a period of time.

### WARNING

**Observe these precautions when using lead acid batteries:**

1. Do not dispose of old lead-acid batteries in fire. This may cause them to burst, spraying acid through the air.
2. Do not short the "+" and "-" terminals together. This will burn open internal connections, making the battery useless.
3. Do not charge 12 volt lead-acid batteries with a voltage greater than 13.8 VDC. High charging voltage may damage the battery or cause it to explode.
4. Do not drop the battery. While lead-acid batteries are well sealed, they may break if dropped or subjected to a strong mechanical shock. If the battery does break and the jelled electrolyte leaks out, neutralize the acid with baking soda and water.

5. Do not charge the battery below 0° C or above +40° C. (32° to 104° F).

### ATTENTION

**Prenez ces précautions lorsque vous utilisez des batteries à acide de plomb:**

1. Ne pas jeter les batteries à acide de plombs dans le feu. Cela peut entraîner leur explosion et des jets d'acides.
2. Ne pas court-circuiter le "+" et le "-". Cela grille l'intérieur de la batterie et rend la batterie inutilisable.
3. Ne pas charger la batterie 12V avec un voltage supérieur à 13,8 V. Un voltage trop élevé peut entraîner l'explosion de la batterie ou peut l'abîmer.
4. Ne pas laisser tomber la batterie. Même si les batteries à acide de plomb sont hermétiques, elles peuvent se casser si on les laisse tomber ou on les soumis à un choc mécanique important. Si la batterie se casse et le produit se repent, neutralisez l'acide avec de l'eau et du bicarbonate de soude.
5. Ne pas charger la batterie en-dessous de 0° C ou au-dessus de +40° C. (32° - 104° F).

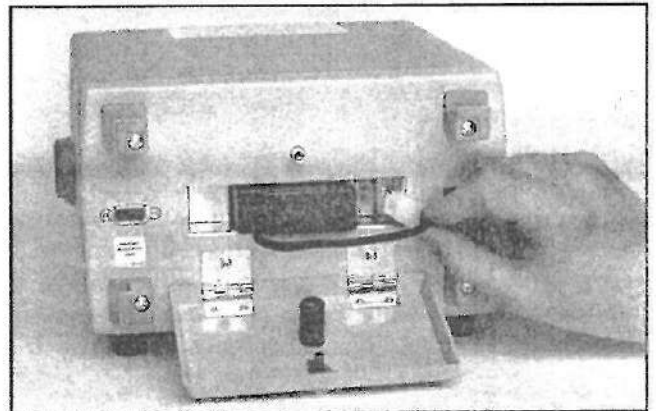

**Fig. 6: The optional BY289 is installed in the LC103 for portable operation.**

**To install the optional BY289 Battery:**

1. Open the BATTERY COMPARTMENT COVER located on the rear of the unit by unscrewing the thumbscrew. Fold the cover down on its hinge.
2. Slide the battery end that does not have the connector attached into the battery compartment. (The wire should be facing out after the battery is in place.)
3. Connect the plug from the battery to the jack inside the battery compartment. Close the battery compartment cover and tighten the thumbscrew to hold the door and battery in place.

*Note: Recharge the BY289 overnight before using it for the first time.*



## Battery Test

The LC103 has a built-in battery test feature that shows the remaining battery charge. A reading of 100% indicates that the battery is fully charged. As the battery charge is used up, the reading will drop. The low battery circuits will turn the unit off shortly after the battery test reading drops to 0%, and before the battery level drops too low for reliable operation. The LC103 never fully discharges the battery, which helps extend the life of the BY289.

### To perform the battery test:

1. With a BY289 installed, press and hold the POWER button.
2. Read the graph and numerical percentage of remaining battery charge in the DISPLAY.
3. If the reading shows 0%, the unit may not operate, or operate for just a short time since the low battery circuit turns the LC103 off at this battery level.



Fig. 7: Press and hold the Power button to read the remaining battery charge.

## Recharging the Battery

The BY289 battery should never be allowed to remain discharged for more than a few hours, since this will shorten its lifetime. The battery must be recharged whenever the battery test reads 0%. However, you should recharge the battery more often than this to lengthen the battery's lifetime and keep the LC103 ready for portable use at all times.

To recharge the battery, simply leave it installed inside the LC103 while the unit is connected to the AC Power Adapter and the Power Adapter is connected to a source of AC power. The charging time required to return the battery to 100% depends on how far it is discharged. The battery will trickle charge while the LC103 is in use and powered from the AC adapter, but it will recharge the quickest if the POWER is turned off. Normally, a battery will completely recharge in about 8 hours with the POWER off.

To operate the LC103 using the optional BY289 battery:

1. Install the BY289 battery into the LC103 battery compartment.

*NOTE: If you are using the BY289 for the first time, be sure to charge the battery before using the LC103. Though factory tested, the BY289 may not be charged when you receive it.*

2. Press the POWER button and release. The WARNING LED will momentarily blink to indicate it is operational and the displays will read "LC103 ReZolver" and "Ready."
3. The LC103 is immediately ready for use. If precise measurements are required, allow the unit to operate for 20 minutes to reach specified accuracy.

## Auto-Off

To conserve battery charge, the LC103 contains an auto-off circuit. This circuit keeps the battery from running down if you should forget to turn the unit off, but keeps the

ReZolver powered up during use. The auto-off circuit will shut the LC103 off after approximately 5 minutes if none of the front panel buttons have been pushed. Pressing any COMPONENT TYPE button, COMPONENT PARAMETERS button, COMPONENT TEST button, or the POWER button reset the auto off circuits. The auto-off circuits are bypassed when the LC103 is operated from the AC Power Adapter.





## STOP TESTING INDICATIONS

The LC103 is designed to provide you with the safest possible method of testing capacitors and inductors. The STOP TESTING indications of the LC103 include a flashing LED indicator on the front panel, a warning message in the display, and an audible alarm. These important features alert you when a potential shock hazard exists in the component or circuit being tested. A hazard may be caused by a blown test lead fuse which prevents the capacitor from discharging, or a circuit charge of 10 volts or more.

### WARNING

When the STOP TESTING LED flashes and the alarm sounds, stop all testing with the LC103. The capacitor may be charged. Follow the procedure below.

### ATTENTION

Lorsque la LED d'arrêt du test clignote et que l'alarme sonore est active, arrêter tous les tests avec le LC103. La capacité peut être chargée. Suivre la procédure suivante.

#### If the STOP TESTING indicators activate:

1. Stop all testing with the LC103.
2. Carefully discharge the capacitor you are testing by connecting a 10 kilohm 1 Watt resistor across the terminals or remove the voltage from the circuit points the test leads are connected to.

## TEST LEADS

The two sets of test leads supplied with the LC103 are made of special, low capacity coaxial cable. Using any other cable may add extra capacity, inductance, and resistance, which may not be within the range of the LC103's lead zeroing circuits. Attempting to zero the leads with another, higher capacitance cable connected may cause the COMPONENT TEST RESULTS DISPLAY to show a "VALUE BEYOND ZEROING LIMIT" message. This indicates that the cable's resistance, capacitance, or inductance is beyond the zeroing limits of the LC103.

#### Adjustable In-Circuit Test Probe

The In-Circuit Test Probe was designed to test as many components in-circuit as possible. The spacing width is adjusted using the knurled wheel. A test activation switch is molded into the probe to make in-circuit testing easier. When a COMPONENT TYPE is selected, pressing the activation switch activates the In-Circuit Capacitor or Inductor test depending on COMPONENT TYPE selection. If no COMPONENT TYPE is selected the LC103 will display an error message stating that you need to enter the type of component under test.

3. Replace the Lead Fuse if blown (see below).
4. Resume testing.

#### Lead Fuse

A 1 amp, Slo-Blo (2AG) fuse is located on the front panel of the ReZolver. This fuse protects the unit from external voltages and current overloads. For your safety, the LC103 ReZolver is equipped with a stop testing alarm. This alarm is triggered when either the fuse blows or the protection circuits open. If either of these conditions occur, the STOP TESTING LED will flash and an audible alarm will be activated.

#### Fuse Replacement

The Lead Fuse is located on the front panel for ease of replacement. Always replace the fuse with a fuse of the same type and rating.

#### To replace the fuse:

1. Remove power from the LC103.
2. Use a small blade screwdriver to turn the fuse holder counterclockwise until the fuse releases.
3. Replace the fuse with the same type and rating. (1 amp, 2AG Slo-Blo)
4. Use the screwdriver to gently push inward while turning the fuse holder clockwise back into place.

### WARNING

Always remove AC power from the circuit when performing any of the LC103's In-Circuit test functions. Failure to do so may result in a shock hazard and damage to the test instrument.

### ATTENTION

Toujours retirer la prise secteur lorsque vous faites des tests dans le circuit. Si cela n'est pas réalisé, l'utilisateur peut recevoir des chocs électriques et l'équipement peut être endommagé.

The test activation button only activates the in-circuit tests, it will not activate any of the out-of-circuit test functions. When an in-circuit test is activated by the test activation button on the probe, the LC103 will display the results for 3 seconds after the button is released. This allows for component testing without having to look away from the circuit. In addition, a short beep will be heard once the LC103 has finished the first complete measurement.



## WARNING

Do not use the Adjustable In-Circuit Test Probe (AP291) to perform the Leakage test. Always use the Test Leads (39G219) when performing the Leakage test.

## ATTENTION

Ne pas utiliser la sonde ajustable pour les test en circuit pendant le test de fuite. Toujours utiliser la sonde (39G219) pour les tests de fuite.

### To use the In-Circuit Test Probe:

1. Remove power from the circuit.
2. Connect the In-Circuit Test Probe (AP291) to the LC103.
3. Zero the test probe.
4. Select a COMPONENT TYPE.
5. Connect the probe tips to the leads of the component under test.
6. Press and hold the In-Circuit Test Probe's test activation button. When the LC103 has finished the first complete update, three short beeps will sound.

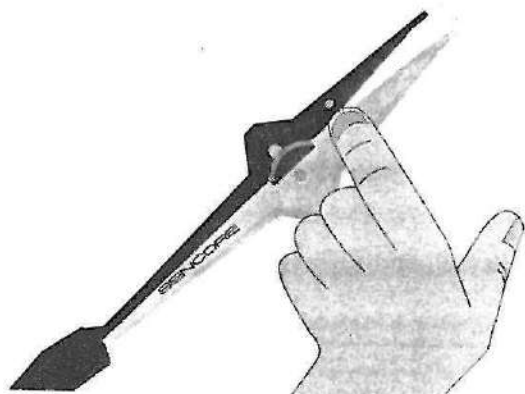

Fig. 8: The test activation button molded into the In-Circuit Test Probe allows easy in-circuit testing without taking your eyes off the circuit.

### Test Lead Mounting Clip

A TEST LEAD MOUNTING CLIP (64G37) is supplied with the LC103. This clip is useful to hold the test leads out of the way when not in use, but keeps them ready and within reach at any time. The mounting clip may be attached on the top of the LC103, on the side of the handle, or wherever it is most convenient. To mount the clip, peel off the backing, place the clip in the desired location and press it firmly in place.

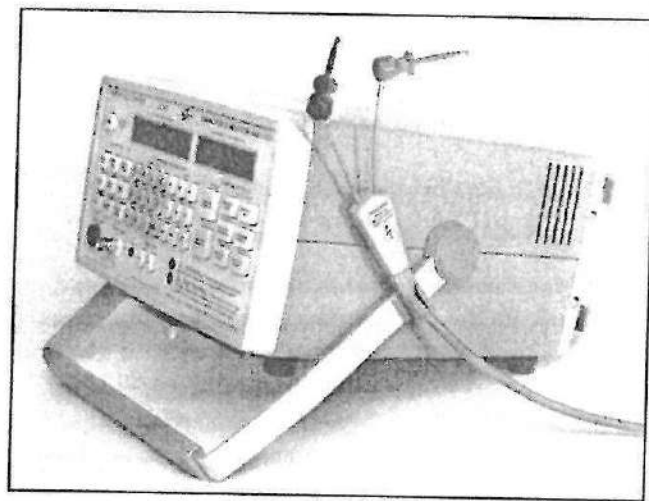

Fig. 9: The test lead mounting clip holds the test leads out of the way, yet ready for use at anytime.

**NOTE:** Mounting the TEST LEAD MOUNTING CLIP to the sides of the ReZolver, will interfere with the handle movement.

### Lead and Probe Zeroing

The Adjustable In-Circuit Test Probe and Out-Of-Circuit Test Leads used with the LC103 have a small amount of capacitance, resistance, and inductance. These must be balanced out before measuring small value capacitors and inductors or before measuring capacitor ESR. The test lead impedance should be zeroed when the LC103 is first turned on. It remains zeroed as long as the unit is powered on. If the LC103 is battery operated and is turned off by the auto-off circuits, however, the leads must be re-zeroed. You will need to re-zero the leads when switching from the in-circuit to out-of circuit leads and vice-versa.

#### To zero the test leads:

1. Turn the LC103 on by pressing the POWER button.
2. Connect the In-Circuit Test Probes or Out-Of-Circuit Test Leads to the TEST LEAD INPUT jack on the front of the ReZolver.
3. Open the In-Circuit Test Probe or place the Out-of-Circuit Test Leads on the work area with the red and black test clips next to each other, but not touching.
4. Press the LEAD ZERO "OPEN" button.
5. The LC103 will display "Lead Zero Open In Progress" and "Done" when finished.
6. Close the In-Circuit Test Probe or connect the red and black test clips together.
7. Momentarily press the LEAD ZERO "SHORT" button.
8. The LC103 will display "Lead Zero Short In Progress" and "Done" when finished.



# ENTERING COMPONENT DATA

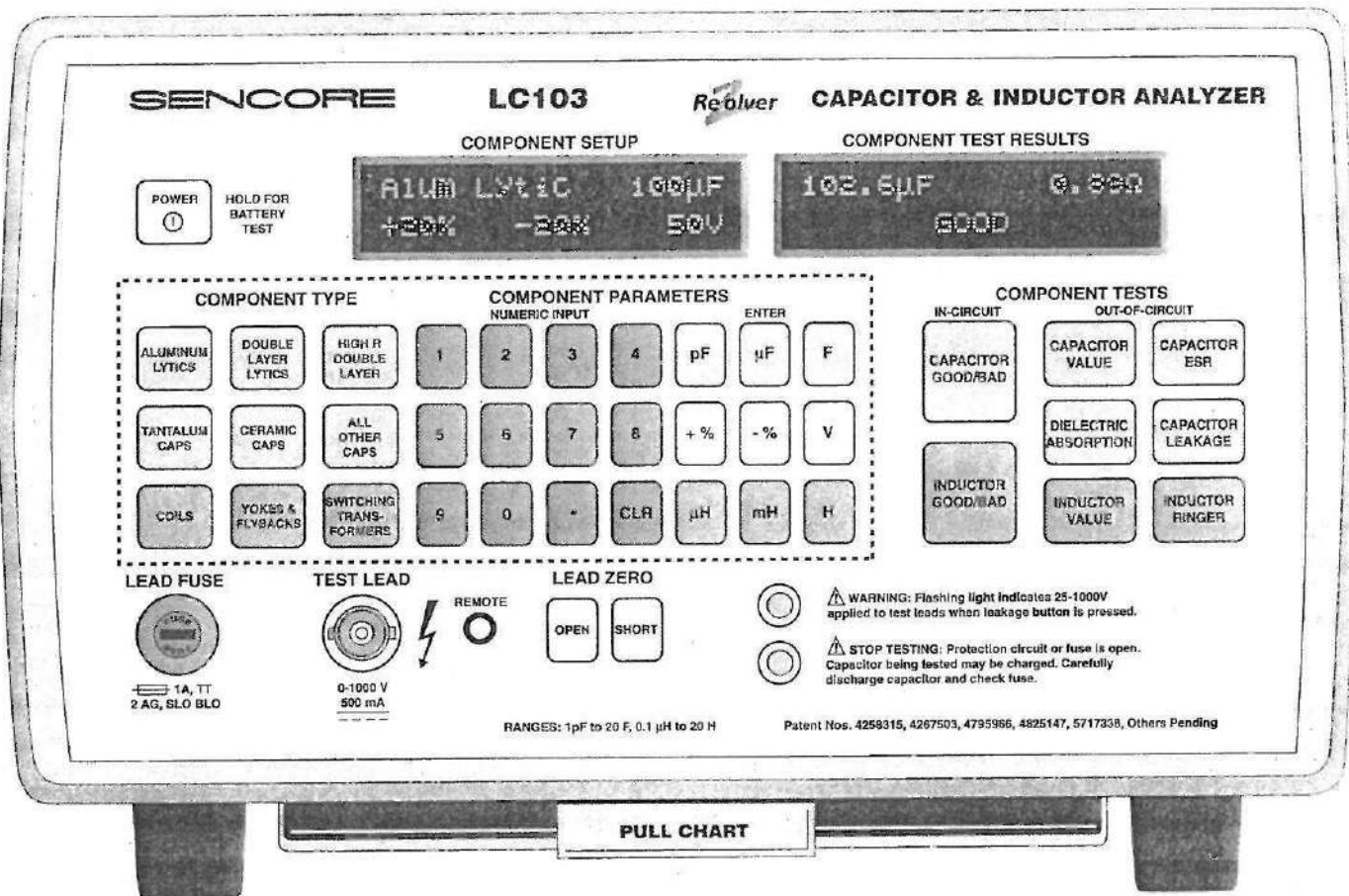

Fig. 10: Controls used for entering component data.

To perform the automatic EIA GOOD/BAD tests with the LC103, you must enter data about the component under test. (All component tests can be performed without entering component data if automatic EIA GOOD/BAD test indications are not desired). The component data is used by the LC103 to make GOOD/BAD determinations.

The component data, which can be entered into the LC103, includes: component type, value, tolerance, and rated working voltage for capacitors, and component type, value, and tolerance for inductors. These parameters are usually marked on the component, or can be determined by looking the component up in a parts list or replacement guide. The APPLICATIONS section of this manual contains information on how to identify capacitor and inductor types.

**NOTE:** All component data can be cleared by pressing the "CLR" button twice on the gray COMPONENT PARAMETERS keypad.

### To enter component type:

1. Press the desired COMPONENT TYPE button. Use the beige color coded buttons when checking capacitors and the blue buttons when checking inductors.
2. The COMPONENT TYPE selected will be shown on the COMPONENT SETUP display.

### To enter component value:

1. Enter a number, up to 6 characters, equal to the value of the capacitor or inductor. Each character will appear in the display as a key is pushed.
  - a. The LC103 accepts numbers up to 6 places before the decimal. (Example: "123456").
  - b. The LC103 accepts numbers up to 4 places after the decimal. (Example: "1.2345").
  - c. Push the "CLR" button once to clear the value entry and start over.
2. Enter the desired capacitor value multiplier or inductor value multiplier.
  - a. The capacitor value range is 1 pF to 20 F. The inductor value range is 0.1 uH to 20 H.
  - b. The LC103 accepts non-conventional value notations, such as ".00001 F", "00002 uF", or "100000 pF"
3. After entering the multiplier, the value will now be shown on the COMPONENT SETUP display. The LC103 is now ready for the next parameter entry.
4. To change an entered value parameter, repeat steps 1 & 2.

### To enter component tolerance:

1. Enter a 1, 2, or 3 digit number up to 100 which equals the "+" value tolerance of the capacitor or inductor under test. If a decimal is included, the LC103 will round to the nearest whole number.



- Press the white "+ %" COMPONENT PARAMETERS button. The "+" tolerance will now be shown on the COMPONENT SETUP display.
- Enter a 1 or 2 digit number up to 99 which equals to the "-" value tolerance of the capacitor or inductor. If a decimal is included, the LC103 will round to the nearest whole number.
- Press the white "- %" COMPONENT PARAMETERS button. The "-" tolerance will now be shown on the COMPONENT SETUP display.

*NOTE: If the "+" and "-" tolerances are the same, simply enter that value and press the "+ %" button followed by the "- %" button.*

**To enter leakage voltage:**

- Enter the desired voltage from 1 to 1000 using the gray keys on the NUMERIC INPUT keypad. A decimal, followed by one digit may be entered, but is not necessary.
- Push the white "V" key to enter the voltage. The voltage will be shown on the COMPONENT SETUP display. For values greater than 25 volts the red WARNING indicator LED will blink.

*NOTE: The voltage is applied to the component Test Leads when the CAPACITOR LEAKAGE test button is pushed.*

- To enter a different voltage, repeat steps 1 & 2.

**⚠ WARNING INDICATION ⚠**

The Warning Indicator LED on the LC103 front panel alerts the user that 25-1,000 V will be applied to the test leads when the leakage button is pressed.

**a. Enter Component Type**

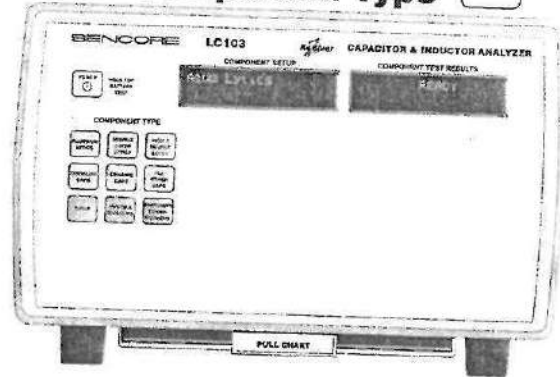

**b. Enter Component Value**

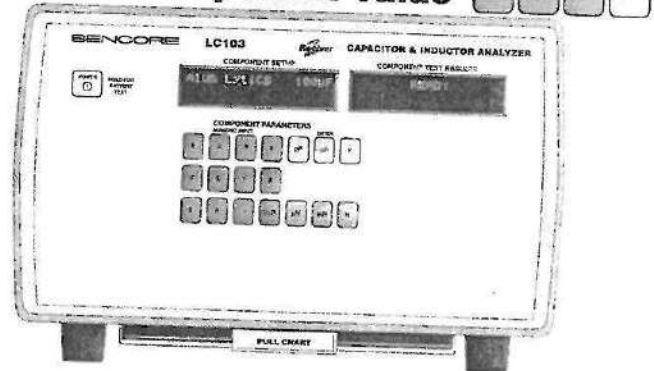

**c. Enter Component Tolerance**

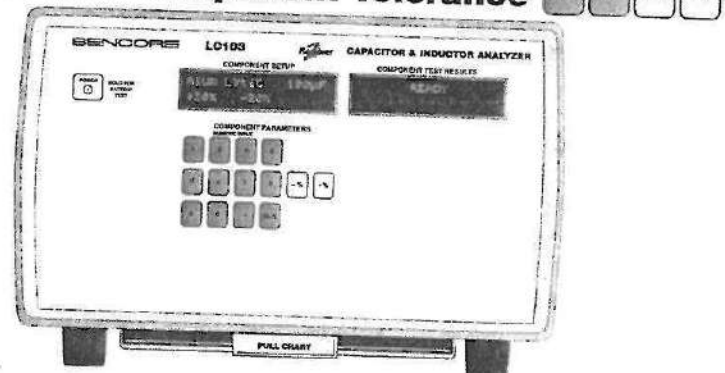

**d. Enter Leakage Voltage**

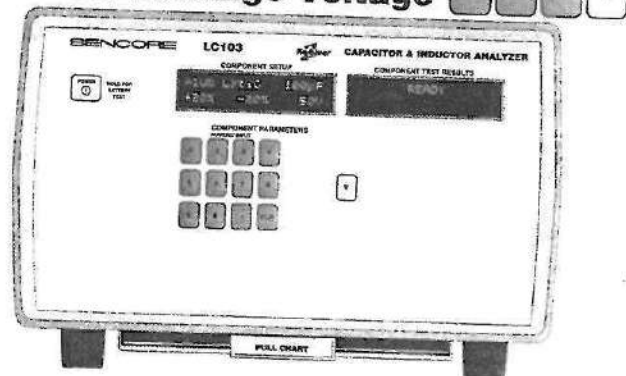

**Fig. 11: Example of entering component data for an Aluminum Electrolytic (a) Component Type = Aluminum Ltyics (b) Value = 100 uF (c) Tolerance = +20%, -20% (d) Leakage Voltage 250V.**



## IN-CIRCUIT CAPACITOR TESTING

The LC103 dynamically tests and measures capacitors greater than 0.002  $\mu\text{F}$  in-circuit for value and greater than 0.02  $\mu\text{F}$  for ESR. Two checks for parallel components that may impact the accuracy of the in-circuit tests are also performed. If parallel components are indicated the LC103 displays a "SUGGEST REMOVAL" message in the COMPONENT TEST RESULTS display. Both a basic test and an automatic EIA GOOD/BAD test can be performed.

When performing the basic test, the LC103 will give a GOOD??/BAD??/SUGGEST REMOVAL indication. The question marks are included because without knowing the component type, value, tolerance, and rated voltage the LC103 cannot determine if the measurements are within specifications.

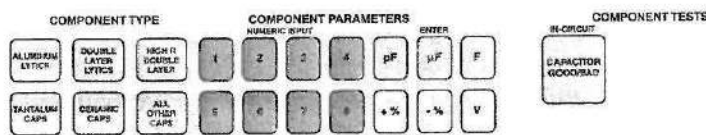

Fig. 12: Controls used for in-circuit capacitor test.

### WARNING

Always remove AC power from the circuit when performing any of the LC103's In-Circuit test functions. Failure to do so may result in a shock hazard and damage to the test instrument.

### ATTENTION

Toujours retirer la prise secteur lorsque vous faites des tests dans le circuit. Si cela n'est pas réalisé, l'utilisateur peut recevoir des chocs électriques et l'équipement peut être endommagé.

### Value And ESR Testing

To perform the basic in-circuit capacitor test:

1. Remove power from the circuit.
2. Connect the in-circuit test probe to the LC103.
3. Zero the test probe.
4. Adjust the probe width to the lead width of the capacitor under test.
5. Touch the probe tips to the capacitor leads.
6. Press and hold the IN-CIRCUIT CAPACITOR TEST button and read the value, ESR, (if the value is greater than 0.02  $\mu\text{F}$ ) and component evaluation results in the COMPONENT TEST RESULTS display.

**NOTE:** The TEST ACTIVATION button on the probe can be used if a capacitor COMPONENT TYPE is selected.

### Automatic EIA GOOD/BAD Testing

To perform the automatic EIA GOOD/BAD test simply enter the capacitors value, tolerance, and voltage rating. When the LC103 returns a GOOD reading that capacitor under test is good. If the display shows BAD, the capacitor should be replaced. If SUGGEST REMOVAL is displayed, the capacitor should be removed from the circuit to be tested.

To perform the automatic EIA GOOD/BAD in-circuit capacitor test:

1. Connect and zero the test probe.
2. Enter the COMPONENT TYPE, rated VALUE, TOLERANCE, and VOLTAGE.
3. Connect to the capacitor under test.
4. Press and hold the TEST ACTIVATION button on the probe or the IN-CIRCUIT CAPACITOR TEST button on the front panel. When using the TEST ACTIVATION button on the probe, wait for the short beep to sound, release the button, and read the display.
5. Read the VALUE and ESR (if the value is greater than 0.02  $\mu\text{F}$ ) measurements on the MEASUREMENT display along with the GOOD/BAD indication.

### SUGGEST REMOVAL Indication

The LC103 may display SUGGEST REMOVAL along with the value and ESR readings. This indicates that the parallel component tests have determined that there is a component that has altered the capacitor measurements. Remove the capacitor to test it more accurately.

### IMPORTANT

Do not hold in the CAPACITOR GOOD/BAD button or Adjustable In-Circuit Test Probe switch while connecting to an In-Circuit capacitor. The LC103 circuitry may be damaged because capacitor discharge protection is lost.



## OUT-OF-CIRCUIT CAPACITOR TESTING

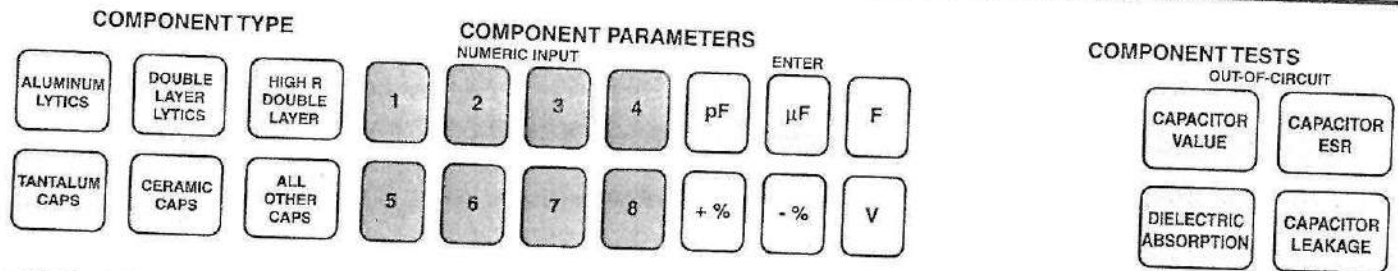

Fig. 13: Controls used for out-of-circuit capacitor tests.

The LC103 ReZolver checks capacitors out-of-circuit for value from 1.0 pF to 20 F in 12 automatically selected ranges. The automatic features of the LC103 ReZolver allow you to perform two levels of automated capacitor testing: basic parameter testing, and automatic GOOD/BAD testing. For basic parameter testing, you simply connect the component to the test leads and push the test button. The LC103 measures the capacitor and displays the test result. You must look up the values of leakage, ESR and dielectric absorption in a table to determine if the capacitor is good or bad.

For automatic GOOD/BAD testing, you first enter the parameters of the capacitor before performing the test. Then the LC103 will display the test results along with a GOOD/BAD indication of the capacitor. Only selected parameters need to be entered into the LC103, depending upon which tests you desire a GOOD/BAD readout for.

## OUT-OF-CIRCUIT CAPACITOR PARAMETER TESTING

The LC103 checks capacitors out-of-circuit for value, leakage, dielectric absorption and equivalent series resistance (ESR). These tests are made directly using the four beige colored OUT-OF-CIRCUIT TEST buttons. Simply connect the component to the Out-Of-Circuit Test Leads, push the desired CAPACITOR TEST button, and read the test result in the display. You can determine if the component is good or bad by comparing the measured ESR and leakage values to the standard values listed in the tables in this manual and in the PULL CHART located conveniently in the LC103.

**NOTE:** Except for the capacitor leakage test, no component parameters need to be entered to perform any out-of-circuit capacitor parameter test. If any blue Inductor Component Type button is selected, "Component Type Selection Error" will appear in the display when you attempt to make a capacitor test. Push the "CLR" key on the gray NUMERIC keypad twice to clear any parameters.

### Component Test Results

The following procedures provide all the necessary information required to perform the out-of-circuit capacitor parameter tests. A more detailed description of each of the capacitor tests and failure modes can be found in the APPLICATIONS section of this manual.

### Measuring Capacitor Value

#### To measure capacitor value:

1. Connect the Out-of-Circuit test leads.
2. Zero the test leads.
3. Connect the capacitor to the test leads. If the capacitor is polarized, be sure to connect the black test clip to the "-" terminal of the capacitor and the red test clip to the "+" capacitor terminal.
4. Press the CAPACITOR VALUE button.
5. Read the value of the capacitor in the COMPONENT TEST RESULTS display.

**NOTE:** The "SHORT" message appearing in the display when the CAPACITOR VALUE button is depressed indicates a resistance of 1 ohm or less at the test leads. Check the test leads. If they are not shorted, the capacitor is bad.

### Measuring Capacitor ESR

Equivalent Series Resistance (ESR) occurs when a capacitor develops abnormally high internal resistance. The LC103 tests capacitors for abnormal amounts of internal resistance using a patented ESR test.

To test a capacitor for excessive ESR, simply press the



CAPACITOR ESR button and compare the measured ESR to the maximum allowable ESR listed in Table 1 for aluminum electrolytic capacitors, and Table 2 for tantalum capacitors. These values are worst-case conditions as defined by the EIA. Some circuits may malfunction due to a capacitor's increasing ESR even if it falls within these limits. If the capacitor is questionable, compare it to a known-good capacitor of the same type, value, and voltage rating.

**To measure capacitor ESR:**

1. Connect the out-of-circuit test leads.
2. Zero the test leads.
3. Connect the capacitor to the test leads. If the capacitor is polarized, be sure to connect the black test clip to the "-" terminal of the capacitor and the red test clip to the "+" capacitor terminal.
4. Press the CAPACITOR ESR button and read the amount of ESR in ohms on the COMPONENT TEST RESULTS display.
5. Compare the measured ESR to the value listed in the following ESR tables for the capacitor type, value, and voltage rating of the capacitor you are testing.

*NOTE: By entering the component type, working voltage, and value parameters for the capacitor, the LC103 will automatically display the measured ESR along with the same GOOD/BAD indication as the ESR tables.*

**Measuring Capacitor Dielectric Absorption**

Dielectric Absorption is often called "battery action" or "capacitor memory" and is the inability of the capacitor to completely discharge. While all capacitors have some minute amounts of dielectric absorption, electrolytics may often develop excessive amounts which affect the operation of the circuit they are used in.

To check a capacitor for dielectric absorption, press the DIELECTRIC ABSORPTION button and compare the value to the chart. A fully automatic EIA GOOD/BAD test may also be used to test for dielectric absorption when COMPONENT TYPE and COMPONENT PARAMETERS are entered.

**To measure capacitor dielectric absorption:**

1. Connect the out-of-circuit test leads.
2. Connect the capacitor to the test leads. If the capacitor is polarized, connect the red test clip to the "+" capacitor terminal and the black test clip to the "-" terminal.
3. Press and hold the DIELECTRIC ABSORPTION button. An arrow (—>) will appear and slowly move through the display indicating that the test is in progress.
4. Read the percentage of dielectric absorption on the COMPONENT TEST RESULTS display.

**Standard Aluminum Electrolytic Capacitors**

Capacity in uF	1.5V	3.0V	6.0V	10V	15V	20V	25V	35V	50V	100V	200V	300V	400V	500V	600V	1000V
<1.0	1411	1411	1411	1411	988	988	988	705	705	564	564	564	564	564	564	564
1.0	663	663	663	663	464	464	464	464	332	332	265	265	265	265	265	265
1.5	442	442	442	442	310	310	310	221	221	177	177	177	177	177	177	177
2.2	302	302	302	302	211	211	211	151	151	121	121	121	121	121	121	121
3.3	201	201	201	201	141	141	141	101	101	80	80	80	80	80	80	80
4.7	141	141	141	141	99	99	99	71	71	56	56	56	56	56	56	56
6.8	98	98	98	98	68	68	68	49	49	39	39	39	39	39	39	39
10	66	66	66	66	46	46	46	33	33	27	27	27	27	27	27	27
15	44	44	44	44	31	31	31	22	22	18	18	18	18	18	18	18
22	30	30	30	30	21	21	21	15	15	12	12	12	12	12	12	12
33	20	20	20	20	14	14	14	10	10	8.04	8.04	8.04	8.04	8.04	8.04	8.04
47	14	14	14	14	9.88	9.88	9.88	7.06	7.06	5.65	5.65	5.65	5.65	5.65	5.65	5.65
68	9.76	9.76	9.76	9.76	6.83	6.83	6.83	4.88	4.88	3.90	3.90	3.90	3.90	3.90	3.90	3.90
100	6.63	6.63	6.63	6.63	4.64	4.64	4.64	3.32	3.32	2.65	2.65	2.65	2.65	2.65	2.65	2.65
150	4.42	4.42	4.42	4.42	3.10	3.10	3.10	2.21	2.21	1.77	1.77	1.77	1.77	1.77	1.77	1.77
220	3.02	3.02	3.02	3.02	2.11	2.11	2.11	1.51	1.51	1.21	1.21	1.21	1.21	1.21	1.21	1.21
330	2.01	2.01	2.01	2.01	1.41	1.41	1.41	1.01	1.01	.804	.804	.804	.804	.804	.804	.804
470	1.41	1.41	1.41	1.41	.988	.988	.988	.706	.706	.565	.565	.565	.565	.565	.565	.565
680	9.76	9.76	9.76	9.76	.683	.683	.683	.488	.488	.390	.390	.390	.390	.390	.390	.390
1000	6.63	6.63	6.63	6.63	.464	.464	.464	.332	.332	.265	.265	.265	.265	.265	.265	.265
1500	4.42	4.42	4.42	4.42	.310	.310	.310	.221	.221	.177	.177	.177	.177	.177	.177	.177
2200	3.02	3.02	3.02	3.02	.211	.211	.211	.151	.151	.121	.121	.121	.121	.121	.121	.121
3300	2.01	2.01	2.01	2.01	.141	.141	.141	.101	.101	.080	.080	.080	.080	.080	.080	.080
4700	1.41	1.41	1.41	1.41	.099	.099	.099	.071	.071	.056	.056	.056	.056	.056	.056	.056
6800	.988	.988	.988	.988	.068	.068	.068	.049	.049	.039	.039	.039	.039	.039	.039	.039
10000	.666	.666	.666	.666	.046	.046	.046	.033	.033	.027	.027	.027	.027	.027	.027	.027
15000	.444	.444	.444	.444	.031	.031	.031	.022	.022	.018	.018	.018	.018	.018	.018	.018
22000	.303	.303	.303	.303	.021	.021	.021	.015	.015	.012	.012	.012	.012	.012	.012	.012
33000	.202	.202	.202	.202	.014	.014	.014	.010	.010							
47000	.141	.141	.141	.141	.010	.010	.010									
56000	.012	.012	.012	.012												
68000	.010	.010	.010	.010												

Table 1 - Maximum allowable ESR for aluminum electrolytics per EIA standards.



# Dipped Solid Tantalum Capacitors

Capacity in $\mu\text{F}$	1.5V	3.0V	6.0V	10V	15V	20V	25V	35V	50V	100V	200V	300V	400V	500V	600V	1000V
<1.0	282	282	282	169.3	169.3	169.3	169.3	141.1	141.1	141.1	141.1	141.1	141.1	141.1	141.1	141.1
1.0	133	133	133	79.6	79.6	79.6	79.6	66.3	66.3	66.3	66.3	66.3	66.3	66.3	66.3	66.3
1.5	88.4	88.4	88.4	53.1	53.1	53.1	53.1	44.2	44.2	44.2	44.2	44.2	44.2	44.2	44.2	44.2
2.2	60.3	60.3	60.3	36.2	36.2	36.2	36.2	30.1	30.1	30.1	30.1	30.1	30.1	30.1	30.1	30.1
3.3	40.2	40.2	40.2	24.1	24.1	24.1	24.1	20.1	20.1	20.1	20.1	20.1	20.1	20.1	20.1	20.1
4.7	28.2	28.2	28.2	16.9	16.9	16.9	16.9	14.1	14.1	14.1	14.1	14.1	14.1	14.1	14.1	14.1
6.8	19.5	19.5	19.5	11.7	11.7	11.7	11.7	11.7	11.7	11.7	11.7	11.7	11.7	11.7	11.7	11.7
10	13.3	13.3	13.3	7.96	7.96	7.96	7.96	7.96	7.96	7.96	7.96	7.96	7.96	7.96	7.96	7.96
15	8.84	8.84	8.84	5.31	5.31	5.31	5.31	5.31	5.31	5.31	5.31	5.31	5.31	5.31	5.31	5.31
22	6.03	6.03	6.03	3.62	3.62	3.62	3.62	3.62	3.62	3.62	3.62	3.62	3.62	3.62	3.62	3.62
33	4.02	4.02	4.02	2.41	2.41	2.41	2.41	2.41	2.41	2.41	2.41	2.41	2.41	2.41	2.41	2.41
47	2.82	2.82	2.82	1.69	1.69	1.69	1.69	1.69	1.69	1.69	1.69	1.69	1.69	1.69	1.69	1.69
68	1.95	1.95	1.95	1.17	1.17	1.17	1.17	1.17	1.17	1.17	1.17	1.17	1.17	1.17	1.17	1.17
100	1.33	1.33	1.33	0.80	0.80	0.80	0.80	0.80	0.80	0.80	0.80	0.80	0.80	0.80	0.80	0.80
150	0.88	0.88	0.88	0.88	0.88	0.88	0.88	0.53	0.53	0.53	0.53	0.53	0.53	0.53	0.53	0.53
220	0.60	0.60	0.60	0.60	0.60	0.60	0.60	0.36	0.36	0.36	0.36	0.36	0.36	0.36	0.36	0.36
330	0.40	0.40	0.40	0.40	0.40	0.40	0.40	0.24	0.24	0.24	0.24	0.24	0.24	0.24	0.24	0.24
470	0.28	0.28	0.28	0.28	0.28	0.28	0.28	0.17	0.17	0.17	0.17	0.17	0.17	0.17	0.17	0.17
680	0.20	0.20	0.20	0.20	0.20	0.20	0.20	0.12	0.12	0.12	0.12	0.12	0.12	0.12	0.12	0.12
1000	0.13	0.13	0.13	0.13	0.13	0.13	0.13	0.08	0.08	0.08	0.08	0.08	0.08	0.08	0.08	0.08
1500	0.09	0.09	0.09	0.09	0.09	0.09	0.09	0.05	0.05	0.05	0.05	0.05	0.05	0.05	0.05	0.05
2200	0.06	0.06	0.06	0.06	0.06	0.06	0.06	0.04	0.04	0.04	0.04	0.04	0.04	0.04	0.04	0.04
3300	0.04	0.04	0.04	0.04	0.04	0.04	0.04	0.02	0.02	0.02	0.02	0.02	0.02	0.02	0.02	0.02
4700	0.03	0.03	0.03	0.03	0.03	0.03	0.03	0.02	0.02	0.02	0.02	0.02	0.02	0.02	0.02	0.02
6800	0.02	0.02	0.02	0.02	0.02	0.02	0.02	0.01	0.01	0.01	0.01	0.01	0.01	0.01	0.01	0.01

Table 2 - Maximum allowable ESR for tantalum electrolytics per EIA standards.

Compare the measured D/A to the amount listed in Table 3 for the capacitor type you are testing to determine if the capacitor is good or bad.

*NOTE: Measurement time varies with the capacitor's value, type, and actual D/A. Most D/A measurements take only a few seconds but on occasion the reading may take up to 10 seconds.*

Maximum Allowable Percent Of D/A	
Capacitor type	Maximum % of D/A
Double Layer Lytic	Meaningless. D/A may normally be very high
Aluminum Lytic	15%
Tantalum Lytic	15%
Ceramic	10%
All others	1%

Table 3 - Maximum amounts of Dielectric Absorption.

## Measuring Capacitor Leakage

Capacitor leakage occurs when current flows (leaks) from one plate through the dielectric to the other plate. The amount of leakage current through the dielectric depends on the voltage applied across the plates. You should always check a capacitor for leakage at (or as close as possible to) its rated voltage. Voltages up to 1000 volts may be applied with the LC103.

Although the EIA specifies the amount of leakage in  $\mu\text{A}$ , at times it is useful to know the amount of capacitor leakage in terms of resistance. For example, it is often easier to visualize what effect a 1 Megohm resistor will have on a high impedance circuit than it is to translate the effect of a capacitor having 1 microamp of leakage. Yet, as far as the circuit is concerned, the DC loading is the same. The LC103 uses a regulated DC power supply to provide voltages for checking capacitor leakage. Because a DC voltage is used, the leakage currents can easily be converted to a resistance. The ReZolver simultaneously displays the leakage in both  $\mu\text{A}$  and Ohms.

To check capacitors for leakage, enter the working voltage of the capacitor and press the CAPACITOR LEAKAGE button. Compare the measured leakage current to the



maximum allowable amounts in the leakage charts. The capacitor is good if the measured leakage is below the amount shown in the chart. A fully automatic GOOD/BAD test may also be used to check capacitors for leakage.

#### To measure capacitor leakage:

1. Connect the capacitor to the test leads. If the capacitor is polarized, connect the red test clip to the "+" capacitor terminal and the black test clip to the "-" terminal.
2. Enter the rated working voltage of the capacitor.

---

#### WARNING

---

The LC103 is designed to be operated by a technically trained person who understands the shock hazard of up to 1000 volts applied to the test leads during the capacitor leakage test. DO NOT hold the capacitor in your hand, or touch the test leads or capacitor leads when making the leakage test.

---

---

#### ATTENTION

---

Le LC103 est fait pour être utilisé par une personne qui est techniquement capable et qui comprend les chocs que peut produire l'équipement (jusqu'à 1000 V) lorsque le test de fuite est utilisé. NE PAS tenir la capacité dans la main ou toucher la sonde ou la patte de la capacité pendant le test de fuite.

---

3. Press the CAPACITOR LEAKAGE button and read the amount of leakage current or dielectric resistance in the COMPONENT TEST RESULTS display.
4. Compare the measured leakage to the maximum allowable amount listed in the Leakage Charts on pages 22 and 23 for the type, value, and voltage rating of the capacitor you are testing.

*NOTE: By entering the Component Type and Value parameters for the capacitor, the LC103 will automatically display the measured leakage along with the same GOOD/BAD indication as the Leakage Charts.*

Voltage will be applied to the capacitor as long as the CAPACITOR LEAKAGE button is pressed. The leakage readings will decrease as the capacitor nears full charge. Some capacitors take only a few seconds to charge up to the applied voltage, while others take longer. The display shows a bar graph estimating the charge on the capacitor. Continue to depress the CAPACITOR LEAKAGE button until the bar graph shows a full charge. Read the leakage reading and compare it to the maximum allowable amount listed in the Leakage Chart.

When the CAPACITOR LEAKAGE button is released, the LC103 discharges the capacitor through an active load. The LC103 contains safety circuits which sense the voltage

across the test leads. Therefore, when you release the CAPACITOR LEAKAGE button after checking a large value capacitor, or after applying a high leakage voltage, the display may show "DISCHARGING CAPACITOR" and the STOP TESTING alarm may activate until the voltage is gone from the test leads. All data input and test buttons will be locked out until the display returns to "Ready."

#### Leakage In Paper, Mica and Film Capacitors

Paper, mica and film capacitors should have extremely small amounts of leakage. Measuring any leakage when checking these types of capacitors indicates a bad component. The leakage test takes several seconds to charge the capacitor before an accurate leakage reading is displayed.

#### Leakage In Ceramic Capacitors

Leakage in ceramic capacitors is generally very low. Ceramic disc capacitors, however, may have small amounts of normal leakage. Ceramic disc capacitors with voltage ratings above 50 WVDC should have less than 1 uA of leakage. Some discs with working voltages less than 50 WVDC may have a lower insulation resistance, and therefore may show somewhat more leakage, depending upon manufacturer. In general, a 10 WVDC ceramic disc capacitor may show as much as 16 uA of leakage, and 25 WVDC ceramic disc may read up to 2.5 uA of leakage and still be considered good.

#### Leakage In Aluminum Electrolytics

Because of their larger value and higher leakage characteristics, aluminum electrolytics take longer to charge. When the capacitor reaches full charge the LC103 displays a current and resistance reading. The leakage current progressively decreases as the dielectric reforms. Initial reading properly indicates leakage current. Compare readings to the maximum amount shown in leakage chart.

#### Leakage In Tantalum Electrolytics

Tantalum electrolytic capacitors have much lower leakage than aluminum electrolytics of the same size and voltage rating. Therefore, tantalum lytics will give a leakage reading in a much shorter time than an aluminum lytic - typically within 2 to 5 seconds. Compare the measured leakage with the amounts shown in the leakage charts to determine if the capacitor is good or bad.

#### Leakage In Non-Polarized (Bi-Polar) Electrolytics

Electrolytic capacitors which are non-polarized should be checked for leakage in both directions. This requires that you measure leakage twice, reversing the LC103 test lead connections for the second test. The maximum allowable leakage for a non-polarized electrolytic in either direction is twice that of a similar polarized electrolytic of similar capacitance value and voltage rating.



# Aluminum Electrolytics

Capacity	1.5V	3.0V	6.0V	10V	15V	20V	25V	35V	50V	100V	200V	300V	400V	500V	600V	1000V
<1.0	5	5	5	5	5	5	5	5	5	5	10	15	20	25	30	50
1.0	5	5	5	5	5	5	5	5	5	5	10	15	20	25	30	50
1.5	5	5	5	5	5	5	5	5	5	8	15	23	30	38	45	232
2.2	5	5	5	5	5	5	5	5	6	11	22	33	44	199	218	281
3.3	5	5	5	5	5	5	5	6	8	17	33	50	218	244	267	345
4.7	5	5	5	5	5	5	6	8	12	23	47	225	260	291	319	411
6.8	5	5	5	5	5	7	9	12	17	34	221	271	313	350	383	495
10	5	5	5	5	8	10	13	18	25	50	268	329	379	424	465	600
15	5	5	5	8	11	15	19	26	38	232	329	402	465	520	569	735
22	5	5	7	11	17	22	28	39	199	281	398	487	563	629	689	890
33	5	5	10	17	25	33	41	204	244	345	487	597	689	771	844	1090
47	5	7	14	24	35	47	206	243	291	411	582	712	823	920	1008	1301
68	5	10	20	34	192	221	247	293	350	495	700	857	990	1106	1212	1565
100	8	15	30	50	232	268	300	355	424	600	849	1039	1200	1342	1470	1897
150	11	23	45	232	285	329	367	435	520	735	1039	1273	1470	1643	1800	2324
220	17	33	218	281	345	398	445	526	629	890	1259	1541	1780	1990	2180	2814
330	25	50	267	345	422	487	545	645	771	1090	1541	1888	2180	2437	2670	3447
470	35	225	319	411	504	582	650	770	920	1301	1840	2253	2602	2909	3186	4113
680	192	271	383	495	606	700	782	926	1106	1565	2213	2710	3129	3499	3832	4948
1000	232	329	465	600	735	849	949	1122	1342	1897	2683	3286	3795	4243	4648	6000
1500	285	402	569	735	900	1039	1162	1375	1643	2324	3286	4025	4648	5196	5692	7348
2200	345	487	689	890	1090	1259	1407	1665	1990	2814	3980	4874	5628	6293	6893	8899
3300	422	597	844	1090	1335	1541	1723	2039	2437	3447	4874	5970	6893	7707	8443	
4700	504	712	1008	1301	1593	1840	2057	2434	2909	4113	5817	7125	8227	9198		
6800	606	857	1212	1565	1916	2213	2474	2927	3499	4948	6997	8570	9895			
10000	735	1039	1470	1897	2324	2683	3000	3550	4243	6000	8485					
15000	900	1273	1800	2324	2846	3286	3674	4347	5196	7348						
22000	1090	1541	2180	2814	3447	3980	4450	5265	6293	8899						
33000	1335	1888	2670	3447	4221	4874	5450	6448	7707							
47000	1593	2253	3186	4113	5038	5817	6504	7695	9198							
56000	1739	2459	3478	4490	5499	6350	7099	8400								
68000	1916	2710	3832	4948	6060	6997	7823	9256								
100000	2324	2396	4648	6000	7348	8485	9487									
150000	2846	4025	5692	7348	9000											
200000	3447	4874	6893	8899												

**Table 4 - Maximum allowable leakage for aluminum electrolytics per EIA standards.**

### Leakage charts

The following leakage charts list the maximum amount of allowable leakage for the most common aluminum electrolytics and dipped solid tantalum capacitors. These charts are duplicated on the PULL CHART below the LC103. Good capacitors (as far as leakage is concerned) will measure lower than the amounts shown in the Leakage Charts. When measuring leakage, you do not need to wait for the readings to drop to zero or to its lowest point. The capacitor is good for any leakage reading which is lower than the amount shown in the chart.

Leakage values shown in Table 4 for aluminum electrolytic capacitors are the worst-case conditions, as specified by the

Electronic Industries Association (EIA) standard RS-395. The values are determined by the formulas:  $L = 0.05 \times CV$  (for CV products less than 1000) or  $L = 6 \times \text{square root of } CV$  (for CV products greater than 1000). (The CV product is equal to the capacitance value multiplied by the voltage rating).

The tantalum capacitor leakage values listed in Table 5 are for the most common type of tantalum capacitors - dipped solid, type 3.3. These values are specified by EIA standard RS-228B, following the formula:  $L = 0.35 \times \text{square root of } CV$ . In a few applications outside of consumer service, tantalum capacitors other than type 3.3 may be encountered. Refer to the manufacturers specifications for the maximum allowable leakage for these special capacitor types.



## Dipped Solid Tantalum Capacitors

Capacity	1.5V	3.0V	6.0V	10V	15V	20V	25V	35V	50V	100V	200V	300V	400V	500V	600V	1000V
<1.0	1.0	1.0	1.0	1.0	1.0	1.0	1.0	1.0	1.0	3.5	4.9	6.1	7.0	7.8	8.6	11
1.0	1.0	1.0	1.0	1.0	1.0	1.0	1.0	1.0	1.0	3.5	4.9	6.1	7.0	7.8	8.6	11
1.5	1.0	1.0	1.0	1.0	1.0	1.0	1.4	1.0	2.0	4.3	6.1	7.4	8.6	9.6	11	14
2.2	1.0	1.0	1.0	1.0	1.0	1.0	1.8	1.2	2.0	5.2	7.3	9.0	10	12	13	16
3.3	1.0	1.0	1.0	1.0	1.0	1.5	2.2	2.0	3.0	6.4	9.0	11	13	14	16	20
4.7	1.0	1.0	1.0	1.0	1.5	2.0	2.6	2.5	3.5	7.6	11	13	15	17	19	24
6.8	1.0	1.0	1.0	1.5	2.0	2.5	3.0	3.0	6.5	9.1	13	16	18	20	22	29
10	1.6	1.6	1.6	2.0	2.5	3.0	4.0	5.0	7.8	11	16	19	22	25	27	35
15	2.2	2.2	2.2	2.5	3.0	4.0	7.0	5.0	9.6	14	19	23	27	30	33	43
22	2.8	2.8	2.8	3.0	5.0	9.5	10	10	12	16	23	28	33	37	40	52
33	3.4	3.4	3.4	5.0	7.5	15	10	11	14	20	28	35	40	45	49	64
47	4.0	4.0	4.0	10	10	15	15	16	17	24	34	42	48	54	59	76
68	5.0	5.0	5.0	15	15	20	15	17	20	29	41	50	58	65	71	91
100	10	10	10	15	20	20	17	21	25	35	49	61	70	78	86	111
150	15	15	15	20	20	19	21	25	30	43	61	74	86	96	105	136
220	20	20	20	20	20	23	26	31	37	52	73	90	104	116	127	164
330	20	20	20	20	25	28	32	38	45	64	90	110	127	142	156	201
470	24	24	24	24	29	34	38	45	54	76	107	131	152	170	186	240
680	29	29	29	29	35	41	46	54	65	91	129	158	183	204	224	289
1000	35	35	35	35	43	49	55	65	78	111	157	192	221	247	271	350
1500	43	43	43	43	53	61	68	80	96	136	192	235	271	303	332	429
2200	52	52	52	52	64	73	82	97	116	164	232	284	328	367	402	519
3300	64	64	64	64	78	90	101	119	142	201	284	348	402	450	492	636
4700	76	76	76	76	93	107	120	142	170	240	339	416	480	537	588	759
6800	91	91	91	91	112	129	144	171	204	289	408	500	577	645	707	913
10000	111	111	111	111	136	157	175	207	247	350	495	606	700	783	857	1107
15000	136	136	136	136	166	192	214	254	303	429	606	742	857	959	1050	1356
22000	164	164	164	164	201	232	260	307	367	519	734	899	1038	1161	1272	1642
33000	201	201	201	201	246	284	318	376	450	636	899	1101	1272	1422	1557	2011
47000	240	240	240	240	294	339	379	449	537	759	1073	1314	1518	1697	1859	2399
68000	289	289	289	289	353	408	456	540	645	913	1291	1581	1825	2041	2236	2886
100000	350	350	350	350	429	495	553	655	783	1107	1565	1917	2214	2475	2711	3500
150000	429	429	429	429	535	606	678	802	959	1356	1917	2348	2711	3031	3320	4287
200000	495	495	495	495	606	734	783	971	1100	1570	2210	2710	3130	3500	3830	5191

*Table 5 - Maximum allowable leakage for solid tantalum electrolytics per EIA standards.*



# AUTOMATIC GOOD/BAD CAPACITOR TESTING

CAPACITOR TYPE	TESTS TO PERFORM			
	Value	Leakage	D/A	ESR
Aluminum Lytic	X	X	X	X
Double Layer Lytic	X			
Tanfalum	X	X	X	X
Ceramic	X	X		X
All other caps (paper, film, mylar, etc.)	X	X		X

Table 6 - The LC103 will provide an automatic GOOD/BAD test of the capacitor parameters shown here.

The LC103 ReZolver can automatically display a "GOOD/BAD" indication for capacitor parameter tests. The automatic tests are much faster than manual parameter tests, since you do not have to look up the result in a chart, or interpolate between listed values. The LC103 compares the measured values of dielectric absorption, leakage, and ESR to tables and formulas stored in its microprocessor memory. The tables and formulas in the ReZolver memory are the same as those in figures 1 and 2, and are based on EIA standards and manufacturers data. Not every parameter for some capacitor types are specified by EIA standards or manufacturer's data. The LC103 will not produce a "GOOD/ BAD" display for capacitor parameters not covered by industry accepted standards. The capacitor types and parameters which will produce a "GOOD/BAD" indication are listed in Table 7.

These values are worst-case conditions as defined by the EIA. Some circuits may malfunction due to a capacitor's increasing ESR even if it falls within these limits. If the capacitor is questionable, compare it to a known-good capacitor of the same type, value, and voltage rating.

To perform an automatic GOOD/BAD test, enter the capacitor type, capacitance value, and voltage rating of the capacitor to be tested. The LC103 determines the GOOD/BAD limits. If you desire to grade capacitors

according to value, you must also enter the desired "+%" and "-%" value tolerances. The value tolerances, however do not need to be entered for automatic GOOD/BAD tests of leakage, ESR, or dielectric absorption.

### To perform an out-of-circuit, automatic GOOD/BAD capacitor test:

1. Connect the out-of-circuit test leads.
2. Zero the test leads.
3. Connect the capacitor to the test leads.
4. Enter the component type, value, tolerance, and voltage rating of the capacitor to be tested.
5. Press and hold the desired capacitor OUT-OF-CIRCUIT TEST button.
6. Read the test result in the COMPONENT TEST RESULTS display along with the GOOD/BAD indication.
7. The display must show a "GOOD" reading for all of the tests listed in table 6 under the type of capacitor being tested.

**NOTE:** The values listed in the tables and LC103 memory for GOOD/BAD indicating are values as defined by the EIA. Some circuits may malfunction with degraded value, leakage, ESR or dielectric absorption values that are within the EIA established limits. If a capacitor is questionable, compare it to a known good capacitor at the same type, value, and voltage rating.

TEST	Cap Type	Cap Value	+%	-%	Cap Voltage
Cap. Value		X	X	X	
Cap. Leakage	X	X			X
Cap. ESR	X	X			X
Cap. D/A	X	X			X

Table 7 - These parameters must be entered into the ReZolver for complete GOOD/BAD test of a capacitor.



## IN-CIRCUIT INDUCTOR TESTING

The LC103 provides an in-circuit inductor value test for inductor values from 3.18  $\mu\text{H}$  to 3.18 H. When this test is performed, the LC103 also checks for parallel components that may upset the measurement. If there are no parallel components that will upset the measurement, the ReZolver will return an inductance value reading. If the LC103 determines that parallel components will alter the reading it will display SUGGEST REMOVAL along with the measured value.

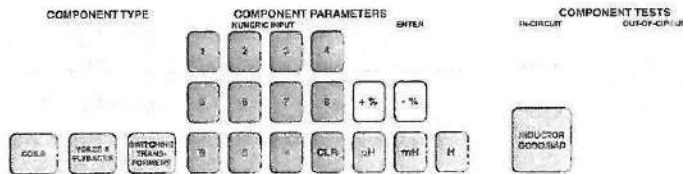

Fig. 14 : Controls used for in-circuit inductor testing.

### WARNING

Always remove AC power from the circuit when performing any of the LC103's In-Circuit test functions. Failure to do so may result in a shock hazard and damage to the test instrument.

### ATTENTION

Toujours retirer la prise secteur lorsque vous faites des tests dans le circuit. Si cela n'est pas réalisé, l'utilisateur peut recevoir des chocs électriques et l'équipement peut être endommagé.

To value test an inductor in-circuit:

1. Connect the in-circuit test probe.
2. Zero the test probe.
3. Adjust the width of the probe tips to the inductor under test.
4. Touch the tips of the probe to the leads of the inductor.
5. Press and hold the IN-CIRCUIT INDUCTOR TEST button and read the results in the COMPONENT TEST RESULTS display.

The LC103 can also perform an automatic GOOD/BAD in-circuit inductor value test. By selecting an inductor COMPONENT TYPE and entering the value and tolerance the ReZolver will return a GOOD or BAD message along with the value measurement.

To perform the automatic GOOD/BAD in-circuit inductor value test:

1. Connect the in-circuit test probe.
2. Zero the test probe.
3. Select an inductor component type.
4. Enter the rated value and tolerance of the inductor.
5. Connect to the inductor under test.
6. Press and hold the TEST ACTIVATION button on the probe or the IN-CIRCUIT INDUCTOR TEST button on the front panel.

## OUT-OF-CIRCUIT INDUCTOR TESTING

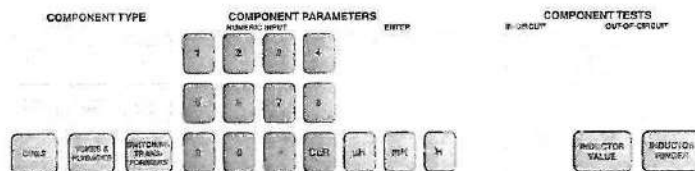

Fig. 15: Controls used for out-of-circuit inductor testing.

The LC103 ReZolver measures the true inductance of coils using a fast, reliable patented test. Coils from 0.1  $\mu\text{H}$  to 19.99 H are automatically measured for value by connecting the test leads and pressing the test button. A patented Ringer test dynamically checks the "Q" of the coil and provides a proven GOOD/BAD check.

### Measuring Inductor Value

Inductors are tested out-of-circuit for value with the LC103 by simply connecting the inductor to the test leads and pushing the INDUCTOR VALUE button. No component type switches need to be selected to measure inductance value. Make sure none of the beige capacitor type buttons are selected, or the LC103 will display "Component Type Selection Error" when the inductor test button is pressed.

To measure inductance value out-of-circuit:

1. Connect the out-of-circuit test leads.
2. Zero the test leads.
3. Connect the inductor to the test leads.
4. Push the INDUCTOR VALUE button.
5. Read the inductance value on the COMPONENT TEST RESULTS display.



**NOTE:** The LC103's display will read "OPEN" if the component connected to the test leads has more than 8 kohms of resistance when the INDUCTOR VALUE button is pressed. Check the connections to the inductor. If you are testing a multi-tap coil or transformer, be sure you are connected to the proper taps. If the connections are good, the inductor has an open winding and is bad.

### Automatic GOOD/BAD Inductor Value Testing

The LC103 will automatically compare the measured value of an inductor to its marked value and display a good or bad result, based on the component being in or out of tolerance. In order for the ReZolver to compare the marked value to the measured value you must program the inductance value and tolerance into the LC103 using the NUMERIC keypad. Then when you push the INDUCTOR VALUE button, the measured inductance value will be displayed along with a GOOD/BAD reading based on the programmed tolerance.

#### To perform the GOOD/BAD inductance value test:

1. Zero the test leads.
2. Connect the inductor to the test leads.
3. Enter the marked value, along with the "+" and "-" tolerance of the inductor to be tested.
4. Press and hold the INDUCTOR VALUE button.
5. If the measured inductance value is within the programmed value tolerance the display will show "GOOD" along with the measured value.
6. If the measured inductance value is outside the programmed value tolerance, the display will show "BAD" along with the measured value.

### The Inductor Ringer Test

A shorted turn in many coils will go unnoticed with a value test, since the shorted turn changes the inductance value only a small amount. The patented Ringer test, however, provides a fast and accurate GOOD/BAD indication of non-iron core coils larger than 10 uH by checking their quality or "Q" factor. The Ringer test is sensitive enough to detect even a single shorted turn on a coil. The ReZolver measures Q by applying a pulse to the coil and counting the number of ringing cycles until the ringing dampens to a preset level. A good coil will indicate "GOOD", and 10 or more rings will be shown in the LC103 display. A shorted turn will lower the Q of the coil, causing the LC103 display to read "BAD" and show less than ten rings.

In addition to air core coils and RF chokes, vertical deflection yokes, horizontal flyback transformers and switching power supply transformers are reliably checked with the Ringer test. The LC103 automatically matches the coil impedance to the necessary testing parameters for the inductor type when the proper Inductor COMPONENT

TYPE switch is selected. Simply select the component type and press the INDUCTOR RINGER test button to obtain the GOOD/BAD indication. Refer to the APPLICATIONS section of this manual for more details on inductor types. The Ringer test can be performed with the coil in-circuit without risk of damage. However, good inductors may not normally produce more than 10 rings when connected in-circuit unless the parallel impedance is quite high. If an inductor does ring good in-circuit, it does not have a shorted turn and can be considered good.

COMPONENT TYPE



**Fig. 16:** The inductor COMPONENT TYPE switches match the Ringer test circuits to the inductor impedance.

#### To perform the Ringer test:

1. Connect the inductor to the LC103 test leads.
2. Select the proper inductor COMPONENT TYPE switch.
3. Press and hold the INDUCTOR RINGER button.
4. Read the number of rings and the condition of the coil as "GOOD" or "BAD" in the LC103 display.

#### Special Notes On Using The Ringing Test:

1. Do not ring coils and transformers having laminated iron cores, such as power transformers, filter chokes and audio output transformers. The iron core will absorb the ringing energy and produce unreliable test results.
2. Good coils below 10 uH may not read "GOOD" because the small inductance value may not allow the coil to ring. Compare the number of rings to a known good coil. The patented Sencore Ringing test is based on the Q of the coil. However, the readings on the ReZolver may not agree with the Q readings obtained using a "Q Meter" or bridge. This is because the Ringing test has been simplified to provide a simple GOOD/BAD test, rather than a frequency dependent reactance/resistance ratio.



## ERROR MESSAGES

---

Several error conditions may occur while using the LC103 which cause an error message to appear in the COMPONENT TEST RESULTS display. These are usually caused by small errors in the operation of the LC103, although severely defective components may also cause certain error conditions. The error conditions are explained below.

**Component Type Selection Error** – This error occurs when a component test is attempted, and either an incorrect COMPONENT TYPE switch is selected for the test, or no COMPONENT TYPE switch is selected when required.

**Possible causes:**

1. Performing a capacitor test with an inductor COMPONENT TYPE switch selected.
2. Performing an inductor test with a capacitor COMPONENT TYPE switch selected.
3. Performing the INDUCTOR RINGER test without an inductor COMPONENT TYPE switch selected.

**Entered Value Beyond Range of Unit** – The component parameter entered via the keypad or RS-232 is beyond the measuring range of the LC103.

**Possible causes:**

1. Entering a capacitance value greater than 19.9 Farads, or less than 1.0 picofarad.
2. Entering an inductance value greater than 19.9 Henrys, or less than 0.1 microhenrys.
3. Entering a leakage voltage greater than 1000 volts.
4. Entering a tolerance percentage greater than +100%, or less than -99%.
5. Entering a tolerance percentage that includes a decimal.

*NOTE: Entering a leakage voltage less than 1 volt will set the leakage supply to 0 volts.*

**Entered Value Beyond Range of Test** – The component parameter entered via the keypad or RS-232 is beyond the limits of the automatic GOOD/BAD test. The component may still be able to be tested, but not for a GOOD/BAD indication.

**Possible causes:**

1. Performing an ESR test with a capacitor value of less than 0.02 uF entered.
2. Performing a D/A test with a capacitor value of less than 0.01 uF entered.
3. Performing an INDUCTOR RINGER test with an inductor value of less than 10 uH entered.

**Value Beyond Zeroing Limit** - The amount of inductance or capacitance at the TEST LEAD INPUT is beyond the range of the zeroing circuits. An open (greater than 20 kohms) or shorted (less than 1 ohm) test lead will cause the display to show "OPEN" or "SHORT."

**Possible causes:**

1. The capacitance at the TEST LEAD input is greater than 1800 pF.
2. The inductance at the TEST LEAD input is greater than 18 uH.
3. The resistance at the TEST LEAD input is greater than 5 ohms.

**No Voltage Entered** - This error occurs when the CAPACITOR LEAKAGE button is pushed and no test voltage has been entered.

**Invalid RS-232 Command** - An improper command was sent to the LC103 via the computer interface.

**Possible causes:**

1. Sending a command that is not recognized by the LC103.
2. Wrong command syntax.

*NOTE: Refer to the COMPUTER INTERFACE section of this manual for information on using the ReZolver with computer control.*

**Component Out Of Test Range** - The component under test exceeds the limits of the test which was attempted.

**Possible causes:**

1. Measuring ESR of a capacitor having a value less than 0.02 uF.
2. Measuring capacitance value on an extremely leaky capacitor.
3. Attempting a capacitor value test with 1 ohm to 2 Megohms of resistance connected across test leads.



# RS-232 OPERATION

All of the LC103 ReZolver tests may be totally automated or incorporated into a computer controlled, automated test system using an RS-232 serial interface. The LC103 may have either of two functions. As a "listener" it can receive instructions from the computer to change functions or ranges. The LC103 listener functions provide complete

automation, as the computer is able to send any values or tolerances needed for good/bad testing comparisons and can select any of the ReZolver test functions.

As a "talker" the LC103 can send readings back to the computer as the computer requests them.

## CONNECTING TO THE COMPUTER

Use a cable with straight through connections on the ground, transmit data, and receive data lines to connect between the computer's serial port and the RS-232 INTERFACE JACK on the rear panel of the LC103. Software handshaking (Xon/Xoff) is used, so hardware handshaking connections on the connector are not needed. The LC103 is configured for 9600 Baud, 8 data bits, 1 stop bit, and no parity. The computer's serial port should be configured the same way. Communications software used in the terminal mode and commercial instrument control software have menu options for setting the port configuration. If you write your own control software, you should specify the serial port configuration when you address the port (in a Basic "open" command, for example).

The LC103 is configured as a DCE (Data Communications Equipment) device, which means that it should be connected to your computer with a cable having DB9 connectors on both ends and straight-through wiring between pins 2, 3, and 5.

Following is a list of the RS-232 9-pin connector lines used by the LC103:

Pin No.	Pin Name	Description
2	RXD	Data received by the computer from the CM125
3	TXD	Data transmitted by the computer to the CM125
5	Gnd	Signal Ground

*Fig. 18: Use a cable having straight through connections for transmit, receive, and ground.*

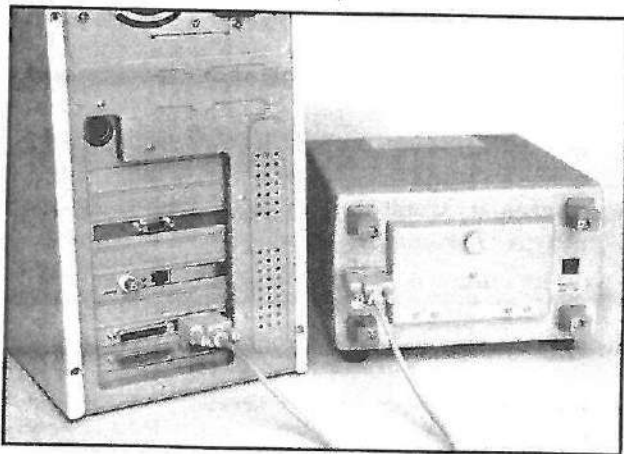

*Fig. 17: Connecting the LC103 to a computer for automated control.*

There are two types of handshaking used by RS-232 devices, software and hardware. With software handshaking, Xon (CTRL-Q) and Xoff (CTRL-S) characters are automatically transmitted on the data lines to control data flow. With hardware handshaking, voltages are placed on separate handshaking lines to control data flow. The LC103 supports only Xon/Xoff software handshaking, which means that hardware handshaking lines are not needed.

## SENDING DATA TO THE LC103

As a listener, the LC103 accepts commands from the computer. These commands can be used to select a function or to send parameters to the LC103 for GOOD/BAD comparison testing. The commands sent to the ReZolver during bus operation duplicate the front panel push buttons. Follow the same programming sequence and range limits as for manual (non-RS-232) operation.

The listener codes consist of one, two, or three characters, and relate to the function being selected or the data being entered. Most listener codes consist only of the code characters. The listener codes used to enter data for good/bad testing consist of a number, followed by the character code.



The codes may be sent by the computer as either upper or lower case letters.

All data sent to the LC103 must end with a carriage return character to be recognized by the LC103. Some computers automatically add this character to the end of every string of data, while others have a special function which adds the carriage return when activated with a software command. If your computer has neither of these options, you can add a linefeed character by storing the character in a variable and then adding this variable to your data before sending it to the bus.

The data or listener codes sent to the LC103 fall into four groups: 1. Component Type Commands, 2. Value Multipliers, 3. Test Function Commands, and 4. General Commands. All listener codes are listed in Table 8. They are also listed in the Simplified Operating Instructions on the PULL-CHART under the unit for ready reference.

**COMPONENT TYPE COMMANDS**

Command	Description
ALM	Aluminum Electrolytics
DBL	Double Layer
TAN	Tantalum Caps
CER	Ceramic Caps
AOC	All Other Caps
HIR	High Resistance Double Layer Lytics
COL	Coils
YFB	Yokes and Flybacks
SWX	Switching Transformers

**VALUE MULTIPLIERS**

Command	Description
pF	PicoFarad
uF	MicroFarad
F	Farad
uH	MicroHenry
mH	MilliHenry
H	Henry
+%	Positive tolerance in percent
-%	Negative tolerance in percent
V	Voltage rating, leakage voltage

**TEST FUNCTION COMMANDS**

Command	Description
CAP	Capacitor value
LKI	Leakage current
LKR	Leakage resistance
D/A	Dielectric Absorption
ESR	Equivalent series resistance
IND	Inductance
RIN	Ringer
CIC	Capacitor in circuit
EIC	ESR in circuit
IIC	Inductance in circuit

**GENERAL COMMANDS**

Command	Description
LDO	Lead zero open
LDS	Lead zero short
NFC	No Function
CPO	Control panel on (front panel operation)
Ctrl R	Continue taking/sending test data
Ctrl O	Return a single reading, (default)

**Table 8 - RS-232 control codes for the LC103.**

**Component Type Commands**

These codes duplicate the front panel COMPONENT TYPE switches and must be sent to the LC103 if you want the test results to be compared to the tables and calculations associated with the LC103 microprocessor. As in non-RS-232 operation, the LC103 uses these to establish the GOOD/BAD limits for the leakage, ESR, dielectric absorption, and coil ringing tests. The good/ bad results may be in error if the wrong Component Type Command is sent.

**Value Multipliers**

These listener codes let the computer send component data information to the LC103 including the ideal component value and value tolerance limits. The codes

duplicate the non-RS-232 operation of the component parameters keypad for entering component data.

As with manual operation, each Value Multiplier Command includes a number, followed by the listener code. There are four types of Value Multipliers for RS-232 programming: 1. Capacitor value, 2. Inductor Value, 3. Percent tolerance, and 4. Capacitor voltage. The first three are only used for LC103 automatic GOOD/BAD comparisons. The capacitor voltage code also sets the LC103 power supply to the selected voltage for the leakage test

When sending a component value to the LC103 it is not necessary to send long strings of zeros to establish decimal readings. Instead, use the value multipliers uF (microfarads), pF (picofarads), and F (farads) for capacitors and uH (microhenries), mH (millihenries), and H (henries) for inductors. The characters may be sent in

upper or lower case. For example, "uF", "UF", or even "Uf" will all produce the same results. The LC103 also ignores any blank spaces between listener code characters. This means that "10UF", "10 UF" and even "10 U F" work equally well.

The complete Value Multiplier code consists of the correct numeric value, the Value Multiplier, and the End Terminator. The following examples show valid commands, with the End Terminators not shown:

**4.7uF**

(enters capacitor value of 4.7 microfarad)

**100 pF**

(enters capacitor value of 100 picofarads)

**15 V**

(enters leakage voltage of 15 volts)

**20+%**

(enters value tolerance of + 20%)

**5H**

(enters inductance value of 5 henries)

**NOTE:** When using multipliers, the numeric portion of the string should be limited to 10 characters.



The amount of Component data which needs to be entered with the RS-232 Value Multiplier codes for a GOOD/BAD test depends on the LC103 function. The chart in Table 9 shows the component parameters needed for each GOOD/BAD test. Sending additional data to the LC103 will not affect the tests.

TEST	Cap Value	Ind Value	+%	-%	Cap Voltage	Compon. Type
Cap. Value	X		*	*		
Cap. Leakage	X				X	X
Cap. ESR	X				X	X
Cap. D/A	X				X	X
Ind. Value		X	*	*		
Ind. Ringing						X

X = Must be entered for GOOD/BAD results.  
 \* = Tolerance are set to zero percent at power-up.

Table 9 - These parameters must be entered for the LC103 to produce a good/bad test result.

**NOTE:** The LC103 will send good/bad indicators back to the computer for each reading if all necessary information has been supplied. To stop the LC103 from sending the "G" or the "B" as part of its returned data, simply send a zero value reading, such as "0 pF". The other Value Multipliers (such as percentages or voltage) will remain in the LC103 memory until changed or until power is removed from the unit.

The plus and minus component tolerance limits must be sent in the correct form. First, the number must be a whole number, with no decimal. Then, the percentages must be within the allowable range. The largest negative number allowed is 99 percent (-99%), and the largest positive number allowed is 100 percent (+100%). Numbers that are outside this range, or that contain a decimal, produce an Error 2 condition.

### Setting the Leakage Voltage

The leakage power supply must be set to the desired voltage before selecting a leakage test with the LKI or the LKR codes. The supply can be set to the nearest tenth of a volt. The listener code simply consists of the desired voltage followed by the letter V and the End Terminator. For example, "100V" sets the supply to produce 100 volts when a leakage function is activated.

The highest voltage which can be programmed into the LC103 is 1000 volts the lowest is 1 volt. Attempting to enter a voltage higher or lower than this range will produce an Error 2 condition.

The leakage power supply only applies power to the test leads after one of the two leakage functions have been selected with the "LKI" or "LKR" listener code. The power supply automatically removes voltage from the test leads when the computer sends any other listener code, or when the front-panel button is pressed.

### WARNING

The warning LED on the front of the LC103 will flash as a reminder that a shock hazard of up to 1000 volts may be applied to the test leads when a leakage test is selected. Use extreme caution when the LED is blinking.

### ATTENTION

La LED d'alerte sur la face avant du LC103 clignote lorsque qu'un risque de choc est possible car plus de 1000V peut être appliqué à la sonde lorsque le test de fuite est utilisé. Faites très attention lorsque la LED est allumée.

**NOTE:** When not using a leakage test, send the listener code "OV" to the LC103 to prevent accidentally applying a voltage to the test leads, unless you want an ESR GOOD/BAD indication.

### Test Function Commands

One of the seven listener Test Function Codes must be sent to the LC103 before the computer can request a reading. The selected function is cancelled by any other listener code sent to the LC103, meaning that a Test Function Command must be the last listener code sent before a reading is requested.

The LC103 will remain in the last function selected until it receives another test function command or listener code. The computer can select an LC103 test, go on to other instruments on the bus, and then come back to the LC103 at a later time to request a reading. This allows tests which require longer times, such as capacitor leakage, to be used without slowing the operation of other instruments on the bus.

The LC103 starts a test from its beginning every time it receives another Test Function Code. Therefore, if the LC103 has been preset to a function for a delayed reading, make certain that the computer does not resend the code just before a reading is taken.

### General Codes

The four general listener codes activate special functions when sent to the LC103. The codes let the computer instruct the LC103 to compensate for the test leads, clear a function, or return control of the LC103 to the front-panel switches.

The LC103 must subtract residual effects of the test leads when testing ESR, and small capacitor or inductor values. The Lead Zero (LDO) and Lead Short (LDS) listener codes duplicate the operation of the front panel LEAD ZERO button to null out the effects of the residual resistance, capacitance, and inductance of the test leads and test fixture. The leads must be shorted before sending



the LDS command and opened before sending the LDO command. If not, the test lead impedance will not be compensated for.

*NOTE: The leads can be nulled manually before turning control of the LC103 over to the automated system. Simply follow the procedures for manually nulling the effects of the leads, as explained on page 14. The LC103 will remember the correct compensation until the power is turned off.*

The No Function Command (NFC) cancels any test that is in progress and places the LC103 into the standby mode (no button pressed). You only need to send "NFC" if you want to clear a test. For example, you may wish to turn off the capacitor value test function while you remove one component and replace it with a different one. It is not necessary to send "NFC" when changing functions with a Test Function Command or when changing component parameters with a Value Multiplier command, since any listener code clears the current function. Sending the "NFC" command when the LC103 is not in a test function has no effect.

## RECEIVING DATA FROM THE LC103

The LC103 will send data to the computer whenever the computer sends the correct "Talk" command. The data returned over the bus will be the same as the reading appearing in the display.

Sending a "Ctrl R" command tells the LC103 to send a reading over the bus every time it updates the reading on the display. The software in the computer determines how many readings are recorded. Some applications only need a single reading, while other applications may require collecting several readings in a row.

Sending a "Ctrl O" command puts the LC103 in a single reading mode. The LC103 will remain in the test function, but the readings will not be sent to the computer until a carriage return or another "Ctrl O" is sent.

A second method to stop the LC103 from sending readings is to send any listener code, including the No Function Code (NFC), to the LC103. This will both stop the readings and place the LC103 into its standby mode. Always use this method if a different component is going to be connected to the LC103.

### IMPORTANT

Do not disconnect or connect any components to the LC103 after performing any capacitor or inductor test without first sending a No Function Command (NFC) or other command first to clear the test function. The LC103 may be damaged if a charged capacitor or static voltage is connected to it. Also, a severe shock hazard may exist to the user if a capacitor is removed after a leakage test without first being discharged.

### ATTENTION

Ne pas déconnecter ou connecter un composant au LC103 après avoir fait un test sur une capacité ou une inductance avant d'avoir d'abord utiliser la commande de -pas de commande- (NFC) ou une autre commande afin de vider la fonction de test. Le LC103 peut être endommagé si une capacité chargée ou une tension statique lui est connectée. De plus, l'utilisateur peut recevoir une décharge électrique importante si la capacité est retirée sans avoir été déchargé après un test de fuite.

The front panel switches are automatically disabled whenever the LC103 receives its first command. The panel will remain locked out for all functions until the Control Panel On (CPO) code is sent or until power to the LC103 is removed.

*NOTE: One exception is the capacitor leakage function. Pressing any of the front-panel buttons will manually unlatch the RS-232 use of the leakage power supply.*

### Data Format

All data returned from the LC103 falls into a standard data format. Each data string is 17 characters long and contains information in four data fields. The software can keep the entire string of characters together, or it can separate the data into three parts for calculations or processing.



*Fig. 19: The data format returned by the LC103 is a string of 17 characters long.*

The four fields of the data string are: 1. Header, 2. Numerical Data Field, 3. GOOD/BAD Indicator, and 4. End Terminator. Each field has the same number of characters for all test functions, allowing the same subroutines to process any returned data. Here are the details for each field of data.



**Header:** The first three characters identify the test function which produced the reading. The three characters sent back from the instrument are usually the same as the test function commands used to select a function when the LC103 acts as a listener. These codes let the software identify the source of the data, confirm that the correct function is producing readings, or label the data for future retrieval.

In certain cases, the Header identifies some special conditions, such as errors or shorted or open components. The computer software should test for these conditions before processing readings for accurate test results, as explained in the section Error Testing below.

**Numerical Data Field:** The 11 spaces following the Header (characters 4 through 14) contain the numerical results of a talker function. The values returned from a test function are in scientific notation, allowing any value to be represented with the same number of characters. Error codes appear as a single digit (from 1 to 7) without the scientific notation.

**GOOD/BAD Indicator:** The single space following the Numerical Data Field (the fifteenth character) is reserved for the results of the automatic LC103 GOOD/BAD tests. The single letter "G", "B", or "R" appears in this position when the LC103 has sufficient information to determine if the reading is good or bad or if the component needs to be removed from the circuit. If a piece of data (such as the tolerance or ideal value) is missing, the position occupied by the GOOD/BAD Indicator is left blank.

*NOTE: A leakage test function may require from 4 to 8 readings for the leakage to settle before providing a GOOD/BAD indication.*

**End Terminator:** All data ends with both a carriage return (ASCII decimal 13) and a linefeed (ASCII decimal 10) character. Many programs respond to either character, while others only respond if the linefeed is present. A few programs, however, may stop accepting data when the carriage-return character is sent, leaving the LC103 hung up waiting to send its last (linefeed) character. If this happens, you may need to put an extra GET or INPUT statement into your program to let the LC103 send its last character into an unused variable.

### Error Testing

Your computer software should test for error conditions (often called "error trapping") after every reading has been collected from the LC103 to prevent an error from causing unexpected results. The software can either report the error or skip over it, but should do one or the other without crashing the program. If your program is particularly advanced, it may test for the type of error (as indicated by the error number returned in the Numerical Data Field) and then branch to different parts of the program which can take the correct action to compensate for the error.

Error	Description
1	Component Type selection error
2	Entered value beyond range of unit
3	Entered value beyond range of test
4	Value beyond zeroing limit
5	No voltage entered
6	Invalid RS232 command
7	Component out of test range
8	Entered string is too long

*Table 10: Error codes returned by the LC103 during RS-232 operation.*

Most errors cause the LC103 to return a Header with the three letters "ERR." A simple test for this Header allows the program to be alerted to the error. The value of the Numerical Data Field tells the computer which of eight errors have occurred. The error codes are summarized in Table 10. Refer to the section entitled "Error Messages" for a more detailed explanation of each error condition.

### Shorted Capacitors

The LC103 automatically senses if a capacitor is shorted before performing a capacitor value test. If a short is detected, the LC103 sends the letters "SHT" as the Header Field of the returned data and displays "SHORT" in the display. Adding one line of program code will test for this condition. This line should appear before any part of the software program which depends on a value reading, so that the value test will be skipped in case of a shorted capacitor.

### Open Inductors

The LC103 automatically senses if an inductor is open (or if the test leads are not connected to the coil) before performing an inductor value test. If an open is detected, the LC103 sends the letters "OPN" as the Header and displays "OPEN" in the display. One additional program line will test for this condition. Place this line before any portion of the program which depends on an inductor value reading, so that the value test will be skipped in case of an open inductor.

### Making Leakage Tests

When testing for leakage on large capacitors, the first reading returned by the LC103 may be outside the normal leakage limits because the capacitor is charging. In the case of electrolytics, several readings may be needed before the capacitor drops to a "GOOD" level, since an electrolytic usually takes some time to charge. This means that the computer software should ignore the first few readings in order to accept a meaningful reading.

There are several ways to handle this in the software. For example, the program could place the LC103 into the leakage function (with the "LKI" listener code) and then set a software timer to insert the correct delay (based on



the normal charging time of the capacitor) before reading the leakage value. During this time, the computer could work with other instruments on the bus to keep the delay from slowing down other steps in the automated system. Rather than a fixed time delay, the software can be written to ignore a certain number of readings before recording the one which is to be checked for value.

In either case, the computer can base its decision on whether the capacitor is good or bad by using the GOOD/BAD Indicator in the returned data. For the automatic GOOD/BAD test to function the capacitor's value, voltage, and type must be sent to the LC103 prior to the test. This allows the LC103 microprocessor to compare the leakage readings to the internal formulas and tables.

### **Making ESR Tests**

The capacitor test for Equivalent Series Resistance may cause unexpected program errors if your software does not handle the returned data correctly. Remember that ESR tests are only valid on electrolytic capacitors with values larger than 0.01 microfarad. Also remember that some

capacitors may have such high levels of ESR that the value is above the measuring range of the test. Therefore, make certain that your software tests for the following conditions.

1. An "ERR 1" occurs if any component type other than ALM, DBL, HIR, or TAN has been sent to the LC103 in its listener mode.
2. An "ERR 3" occurs if the capacitor under test measures less than 0.02 microfarad.
3. An "ERR 7" occurs if the amount of ESR is above 2000 ohms.
4. The leads must be zeroed (either manually or by using the "LDS" listener function) before making ESR tests, or the added lead resistance may cause erroneous results.



# APPLICATIONS

## INTRODUCTION

The procedures explained in the OPERATION section of this manual explain how to use the LC103 ReZolver. Once you become familiar with the basic operation of the ReZolver, you will discover many additional applications of

the unit. This section will provide you with further information on using the LC103 features for extended capacitor and inductor tests, as well as other special applications.

## IDENTIFYING CAPACITOR TYPES

Capacitors are often grouped according to the kind of dielectric that is used to separate the plates, and are named accordingly. For example, an aluminum electrolytic capacitor has an aluminum oxide dielectric, while a mylar capacitor uses mylar dielectric. (Refer to the APPENDIX for an explanation of dielectric and other capacitor theory).

Many different types of capacitors are used in electronics. Each type has certain properties that make it better suited for particular applications. Properties such as temperature coefficient, ESR, dielectric absorption, leakage, voltage break down, and frequency characteristics are taken into account when selecting the capacitor type to be used. When troubleshooting a circuit, it is not important to know why a certain type of capacitor was selected. It is best to simply

replace a bad capacitor with a good capacitor of the same type value and voltage rating. This is especially true when the component is in a "Safety Critical" circuit. Because different capacitor types have different characteristics, it is important that you know what type of capacitor you are testing in order to know if the LC103 test results are acceptable or not.

Capacitors are divided into five different types for testing with the LC103. Each has different parameters which require different GOOD/BAD limits. These five capacitor types have different physical characteristics to determine an unknown capacitor type. These characteristics are explained in the following paragraphs and are summarized in Figure 20.

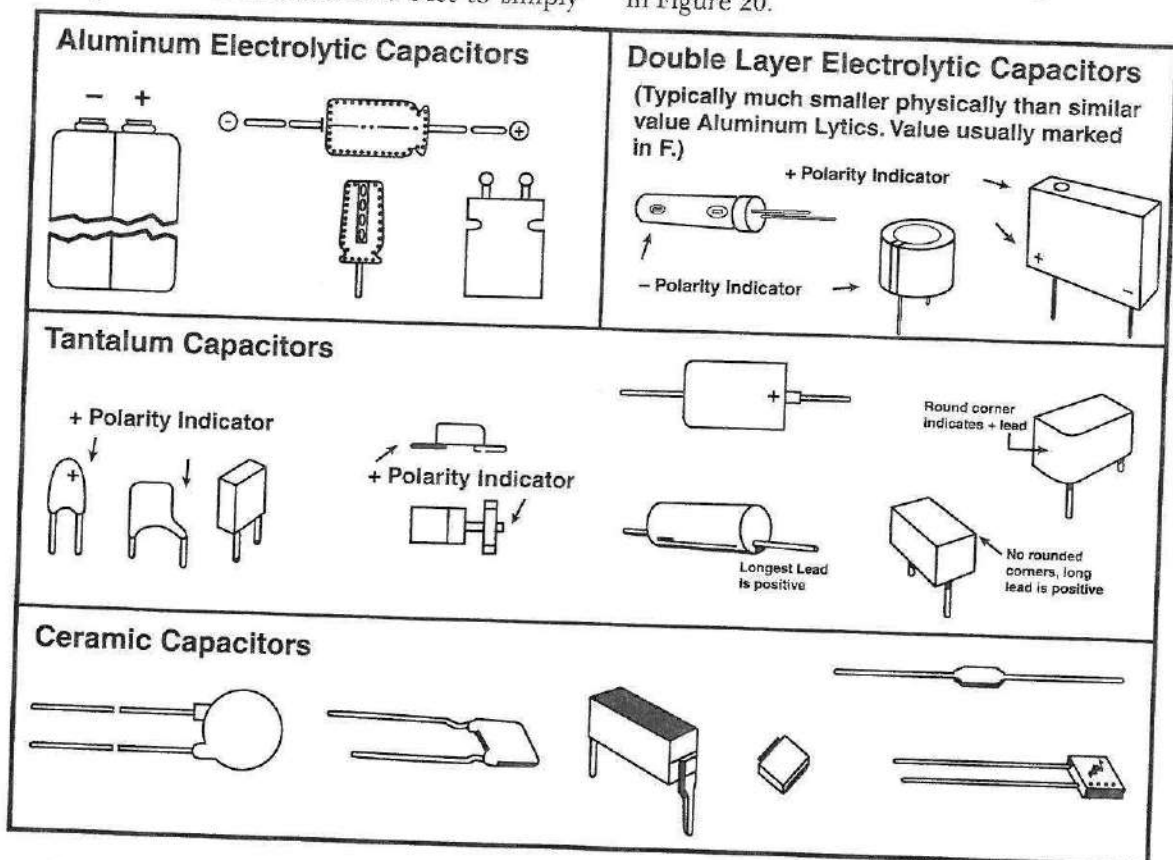

Fig. 20: Each capacitor type may be identified by its unique physical characteristics.



## Aluminum Electrolytics

Aluminum electrolytic capacitors (ALUMINUM LYTICS) are the easiest capacitor type to identify. They are most commonly cylinder shaped and have radial or axial leads. Large value aluminum lytics often have screw terminals or solder lugs. The case of an aluminum lytic usually is rolled in or formed out near the lead end to hold the end cap and seal. All aluminum lytics have a seal that is soft and rubber like to allow gasses to vent. Depending on the physical size of the case, the soft seal may make up the entire end of the case, or it may be just a small section of a hard end cap. Aluminum lytics have the largest physical size to capacity ratio of all capacitor types. These capacitors may also have several sections, with each section having a different capacitance value but sharing the same negative terminal, usually the case. This is unique to aluminum electrolytics, so whenever you encounter a capacitor having several different capacitance value sections, it will be an aluminum electrolytic.

Because of their unique physical characteristics, most aluminum lytics usually aren't easily confused with other capacitor types. Axial lead aluminum lytics, however, may possibly be mistaken for axial lead tantalum lytics. The lead weld is an identifying characteristic of the tantalum electrolytic and is a quick way to differentiate between an axial lead aluminum lytic and a tantalum lytic. Aluminum lytics do not have a lead weld on either terminal.

In addition, surface mount aluminum electrolytic capacitors are becoming increasingly popular. They resemble leaded aluminum lytics in their shape but are much smaller and have very short legs for mounting. Surface mount aluminum lytics can fail in all of the same ways as a standard size capacitor.

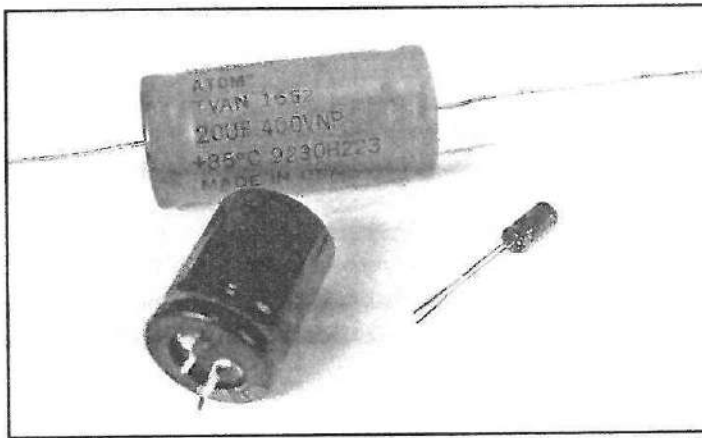

Fig. 21: Various types of aluminum electrolytic capacitors.

## Tantalum Electrolytics

Dipped tantalum electrolytics are replacing aluminum lytics in many electronic circuits. They have less leakage and higher value tolerances than aluminum lytics. Tantalum

electrolytic capacitors are about one half the size of a similar aluminum electrolytic of the same value and voltage rating.

While they may have many shapes, tantalum capacitors always have polarized leads. Lead polarization is often the only way to distinguish a tantalum lytic from another type of capacitor. Once you become familiar with the polarity markings used, tantalum lytics are not difficult to identify. The polarity markings are not meant to be difficult to notice or understand, although if you are not aware of them, they might be overlooked. Pay careful attention so that you do not overlook the polarity indication and misidentify a tantalum capacitor as another type.

The simplest and most common polarity indicator is a "+" sign near one of the leads. This is often used along with a second type of indicator. In addition to the "+" sign, each capacitor shown has a second indication of the "+" lead: a lead weld, a tapered case, a rounded corner, a line, or an extra ridge near the "+" lead.

A "+" indicator is not printed on all tantalum capacitors. In many cases the polarity indicator will simply be the lead weld, a tapered case or rounded corner, a line, or an extra ridge on the case. Several other polarity identifiers are also used. The end or side nearest the plus lead may be painted one color. Also at times, just a dot or a line on the side of the package will be used.

*NOTE: Tantalum capacitors may use dots or stripes to indicate value or tolerance. Do not confuse the value color code for the polarity indicator of a tantalum capacitor. The polarity indicator will be larger and isolated from the color code.*

Tantalum capacitors are also available in the small surface mount or "chip" type. Tantalum chip caps could be confused with ceramic chip caps, since they are similar in size and appearance at first glance. But, a tantalum chip capacitor is polarized and has an easily identifiable positive lead. The polarity identification that may give you the most difficulty in identifying a tantalum capacitor is lead length. The only identification of the positive lead on some tantalum capacitors is that it is longer than the other lead. Of course, this presents no problem when the capacitor is new, but once it has been installed into a circuit board, the

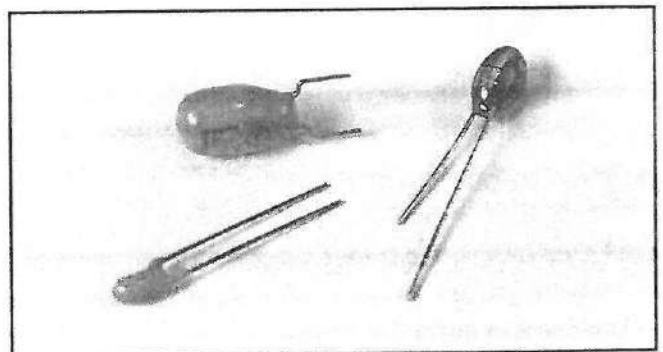

Fig. 22: Various types of tantalum electrolytic capacitors.



leads are cut off to the same length. In this situation, use the circuit as the clue to the cap's type and polarity.

### Double Layer and "High R" Electrolytics

Double layer electrolytic capacitors are commonly known by trade names such as "Supercap" or "Gold Cap." These capacitors are quite easy to identify. Double layer electrolytics have an extremely large capacitance value for their physical size. They are found in various physical shapes and sizes. Their value is marked in Farads, rather than in picofarads or microfarads.

The polarity of a double layer lytic is often printed on the case, although a longer lead may also be used to identify the positive terminal. Some double layer electrolytics use a line next to one lead which may be either "+" or "-". If there is no other marking, the terminal that is part of the metal case is the negative lead.

There are two main types of double layer electrolytics. They are divided between capacitors needed to supply current in the  $\mu\text{A}$  range and capacitors needed to supply current in the mA range. Essentially, the difference is that capacitors needed to supply current in the mA range are typically two or more capacitors in series and have a higher resistance characteristic. For this reason, the LC103 contains two selections for double layer lytic component types, DOUBLE LAYER LYTIC and HIGH R DOUBLE LAYER. Typically, double layer electrolytics having a voltage rating of higher than 4 volts will be "High R."

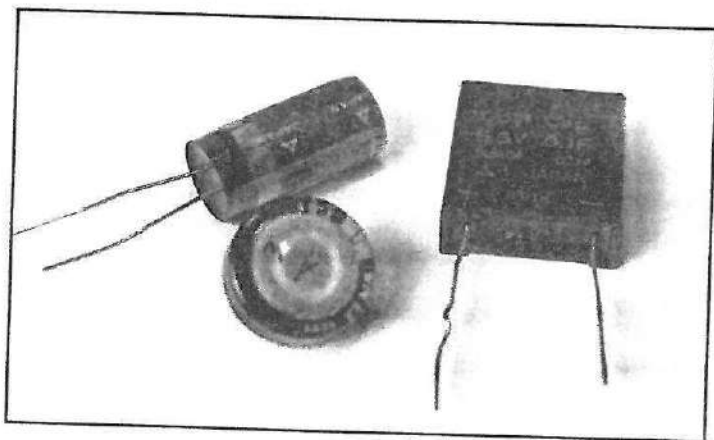

Fig. 23: Various types of double layer electrolytic capacitors.

### Ceramic Capacitors

Ceramic capacitors may be found in many different sizes and shapes. The most common type of ceramic capacitor is the flat, round ceramic disc. The ceramic disc is unique in its shape, and is easily identifiable from other ceramics, and other types of capacitors. The ceramic disc is also unique from other types of ceramic capacitors in that it may have small amounts of normal leakage.

Two other kinds of ceramic capacitors which are easily identified are the axial lead and chip types. Some axial lead ceramic capacitors may look the same as resistors and inductors which also use the same case type. You can easily determine if the component is a resistor, capacitor or inductor from its location in the circuit. The LC103 can also be used to help identify these unknown components as explained in a following section, "Identifying Unknown Components."

There are a few other kinds of ceramic capacitors besides the three types identified here. These types, such as molded ceramics and encapsulated ceramics, are very similar in appearance to film capacitors, and are difficult to differentiate from films by physical appearance. This presents no problem, when testing these ceramics with the LC103 since any leakage or D/A in a ceramic capacitor, other than a ceramic disc, is not allowable. If you are unable to identify the capacitor as a ceramic, test it as an "ALL OTHER CAPS" type.

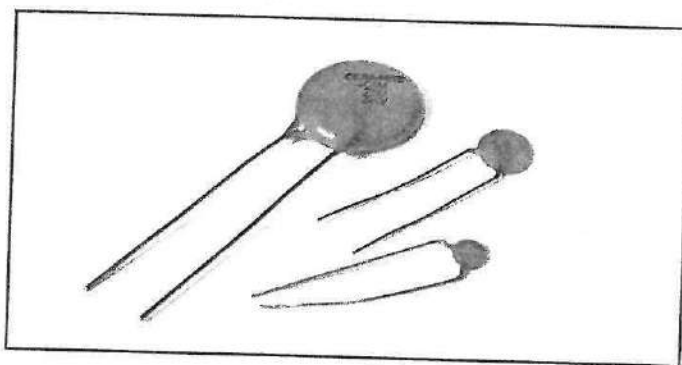

Fig. 24: Various types of ceramic capacitors.

### All Other Capacitors

The final capacitor type grouping for LC103 ReZolver GOOD/BAD testing is "ALL OTHER CAPACITORS." As its name implies, capacitors in this category do not have the electrical (or physical) characteristics to fit into any of the other categories. Capacitors included in this grouping are films, micas, air dielectrics, papers, oil filled capacitors, and other similar types. (There are numerous types of film capacitors such as mylar, polyester, polycarbonate, polystyrene, and polypropylene). Though each of these capacitor types have different dielectrics and somewhat different parameters, they are all similar in that when tested with the LC103, they should have no dielectric absorption or leakage. If you measure any leakage, or D/A in an "ALL OTHER CAPACITOR" type it is bad.

**NOTE:** When replacing any of these capacitors, always replace it with the same type originally used in the circuit. For example, a mylar film capacitor should only be replaced with another mylar film. This is especially important for components in areas of the schematic designated as "Safety Critical."



## IDENTIFYING INDUCTOR TYPES

Inductors, like capacitors, may be found in many shapes and sizes depending on the application in which they are used. The LC103 will provide an accurate Ringer test on all types of air core and ferrite core inductors, provided the proper Inductor COMPONENT TYPE switch is selected. Each inductor type has a normal range of impedance, and the Inductor COMPONENT TYPE switches match the impedance of the LC103 Ringer circuits to the particular inductor type being tested. With the proper COMPONENT TYPE switch selected, an inductor with just a single shorted turn will produce a "BAD" indication in the Ringer test.

Air and ferrite core inductors break into three, easy to identify types: Yokes and Flybacks, Switching Transformers, and Coils. Select one of these three Inductor COMPONENT TYPE switches when performing the Ringer test.

### Yokes and Flybacks

Yokes are used exclusively in video applications to deflect a CRT electron beam. They can not be easily mistaken for any other type of inductor. Yokes have a ferrite core, surrounded by two pairs of windings, which fits over the CRT neck. It is held in place with a plastic shell attached to the CRT neck.

Flyback transformers are also easy to identify. They too are used exclusively in video applications, and produce high voltage for the CRT. A flyback has several terminals which are often soldered to a PC board chassis. One or two heavily insulated leads exit the flyback to carry high voltage to a tripler, or to the CRT directly.

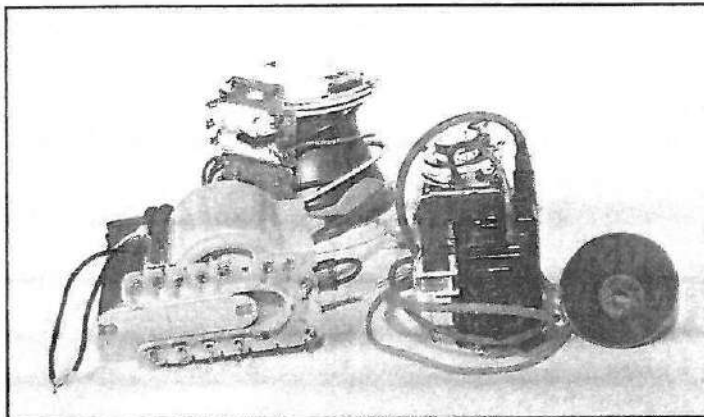

*Fig. 25: Yokes and flybacks are easily identified.*

### Switching Transformers

Switching transformers are used in power supply circuits to step voltages up or down. However, they are much different from conventional power transformers in both appearance and operation. Power transformers usually operate at 60 Hz, and therefore contain a laminated iron core which is often

visible. Because the iron core is low Q and absorbs all ringing energy, power transformers cannot be tested with the LC103.

Switching transformers, on the other hand, are much smaller and lighter than power transformers. They are wound around a ferrite core which easily rings when good. Switching transformers operate at much lower currents and much higher frequencies than power transformers.

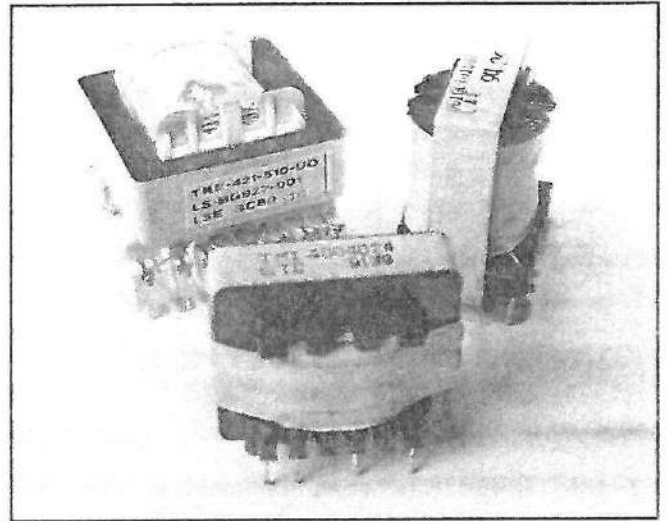

*Fig. 26: Common types of switching transformers.*

### Coils

All non-iron core inductors which can not be classified as yokes, flybacks, or switching transformers are tested with the "COILS" INDUCTOR COMPONENT TYPE switch selected. These include RF/IF transformers, RF chokes, postage stamp inductors, axial lead inductors, free form coils, as well as some other types.

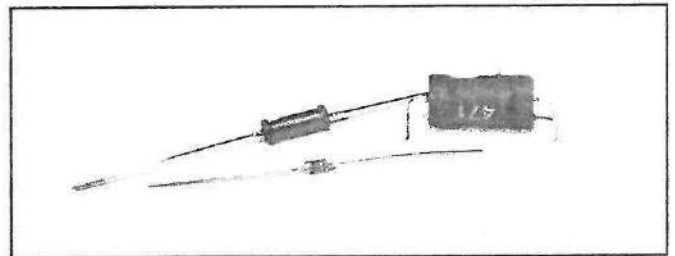

*Fig. 27: Common types of coils.*



# IDENTIFYING UNKNOWN COMPONENTS

Occasionally you may encounter small value inductors and axial lead ceramic capacitors which look like the more common axial lead film resistor. If these components get mixed up in your parts bin, you may have difficulty identifying the component. This may also be a concern with chip capacitors, chip inductors, and a few other axial lead inductors and capacitors on which the markings are difficult to interpret or are not visible.

You can use the LC103 tests to sort these component types from each other. Figure 28 shows, in flow chart form, the procedure you need to follow. Before beginning the test, zero the test leads. You begin identifying the component with a capacitor value test. Depending on the reading, you either use the leakage test or inductor value test to further isolate the component. Finally, if the component appears to be an inductor, you use the ringing test as confirmation.

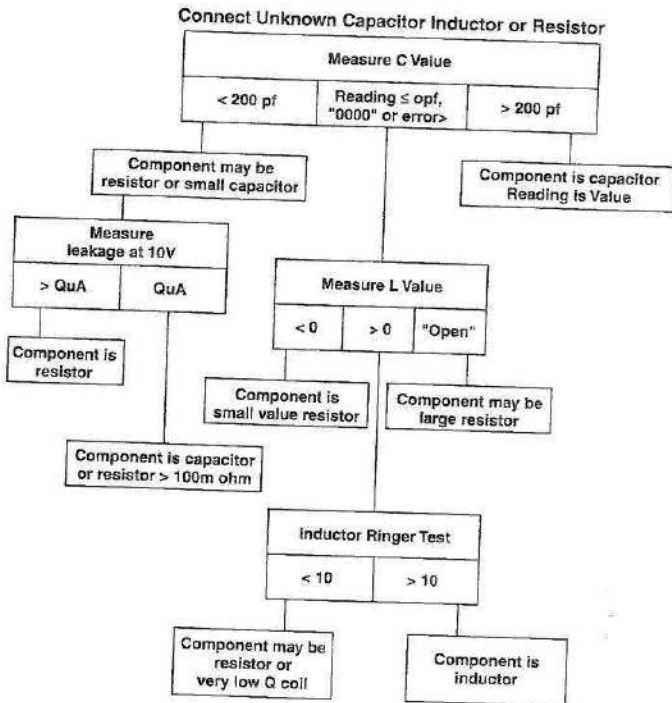

Fig. 28: Use this flow chart to help identify small axial lead inductors, capacitors, and resistors from one another.

## WARNING

Do not apply more than 10 volts across an unknown capacitor resistor or inductor. Most chip, "film" package, and axial lead inductors and capacitors will have voltage ratings greater than 10 volts. If in doubt about an unknown component's voltage rating, use another method to identify it, if possible, or use a lower test voltage.

## ATTENTION

Ne pas appliquer plus de 10 volts sur une capacité, une résistance ou une bobine de valeur inconnue. La plupart des capacités, et inducteurs demandent un voltage supérieur à 10V. Si vous avez des doutes sur le voltage du composant utiliser une autre méthode pour l'identifier, si c'est possible, ou utiliser le test avec un voltage bas.

NOTE: This test is only intended to help you sort inductors, capacitors and resistors in "film resistor" type, chip type or small axial lead packages which are difficult to identify by physical appearance or any other means.

## CAPACITOR TESTING

### Capacitance Measurement Accuracy

The LC103 measures the capacitor charge time as the capacitor is charged with a constant current. This gives the most accurate measurement of true capacity available. Capacity values measured with the ReZolver may or may not exactly match readings on other instruments which use a different measuring technique. Bridges, for example, measure capacitive reactance using an AC signal. Capacitive reactance changes with frequency. Therefore, two bridges operating at different frequencies will give different capacity readings.

Electrolytic capacitors normally read up to or slightly higher than their marked value when measured with the LC103. This is because electrolytics are marked according to their value as measured on an AC-type impedance bridge. The value of an electrolytic changes greatly with the

measurement frequency. In addition, electrolytics most commonly fail due to leakage, dielectric absorption, or ESR. When an electrolytic does change value, the value drops far below the marked value.

### Measuring Small Capacitance Values In Noisy Environments

The sensitive ReZolver measuring circuits may be affected by large, outside signals (such as the AC fields radiated by some lights and power transformers) when small capacitance values are being measured. Special circuits in the LC103 help minimize noise pickup and stabilize the readings.

Measurements of small value capacitors in noisy environments may be further improved by grounding the LC103 case to earth ground. When possible, power the



Change From	To	Farads	Microfarads	Nanofarads	Picofarads
Farads			move decimal 6 places right	move decimal 9 places right	move decimal 12 places right
Microfarads		move decimal 6 places left		move decimal 3 places right	move decimal 6 places right
Nanofarads		move decimal 9 places left	move decimal 3 places left		move decimal 3 places right
Picofarads		move decimal 12 places left	move decimal 6 places left	move decimal 3 places left	

Table 11 - Capacitor value conversion chart

LC103 with the PA251 AC Power Adapter connected to a properly grounded AC outlet. The PA251 Power Adapter maintains the third wire ground shield and keeps the noise away from the measuring circuits inside the ReZolver.

### Interpreting Capacitor Value Readings

The LC103 ReZolver automatically displays the three most common capacitor values of picofarads (pF), microfarads (uF), and Farads (F). When measuring capacitors with the LC103, you may encounter some capacitors with a value marked without a decimal, such as "25000 pF", but that read ".0250 uF" on the LC103 display. You may also encounter, as an example, a capacitor which is marked "3300 pF" by some manufacturers, yet an identical replacement is marked ".0033 uF" by another manufacturer.

As these examples illustrate, capacitors can be marked in pF, uF or even F. A fourth value multiplier, the nanofarad (nF) is seldom used to mark a capacitor, but is used occasionally in design and industry. Table 11 will help you to easily convert from one reading to another.

### In-Circuit Capacitor Test

In many cases it is desirable to test a capacitor in-circuit and then, if necessary, remove it to test it more completely out-of-circuit. Reliably testing capacitors in circuit can be tremendously time saving. Due to the wide variety of circuits, there are a few things to keep in mind as you use the LC103 to test capacitors in-circuit.

1. Many circuits, especially power supplies, place two or more capacitors in parallel. In this case, you will see a high capacitor value reading. This is normal since parallel capacitance adds. When the

LC103 returns a capacitor value that is higher than the capacitor being tested you may want to remove the suspect capacitor to test it accurately.

2. Sometimes the LC103 will return a value and ESR reading accompanied by "SUGGEST REMOVAL." In this case, there are components surrounding the capacitor that have upset the measurements. For reliable test results this capacitor would be best tested out-of-circuit.
3. Some circuits require capacitors with less ESR than the EIA specifies. When testing these capacitors, the LC103 may show a "GOOD" reading but the capacitor may not work in the circuit. Refer to the manufacturer's specifications or compare to a known-good capacitor.

The following flow chart explains how the ReZolver decides which indicator to display with the value and ESR readings when performing an in-circuit capacitor test.

When the In-Circuit Capacitor Test button is pressed the LC103 begins its parallel component checks. If this test fails the ReZolver displays the value and ESR measurements along with SUGGEST REMOVAL message. If the parallel component check passes the LC103 checks to see if the COMPONENT PARAMETERS have been entered. If so, it compares all measurements to these values and displays a GOOD message along with the value and ESR measurements if they fall within the specified parameters

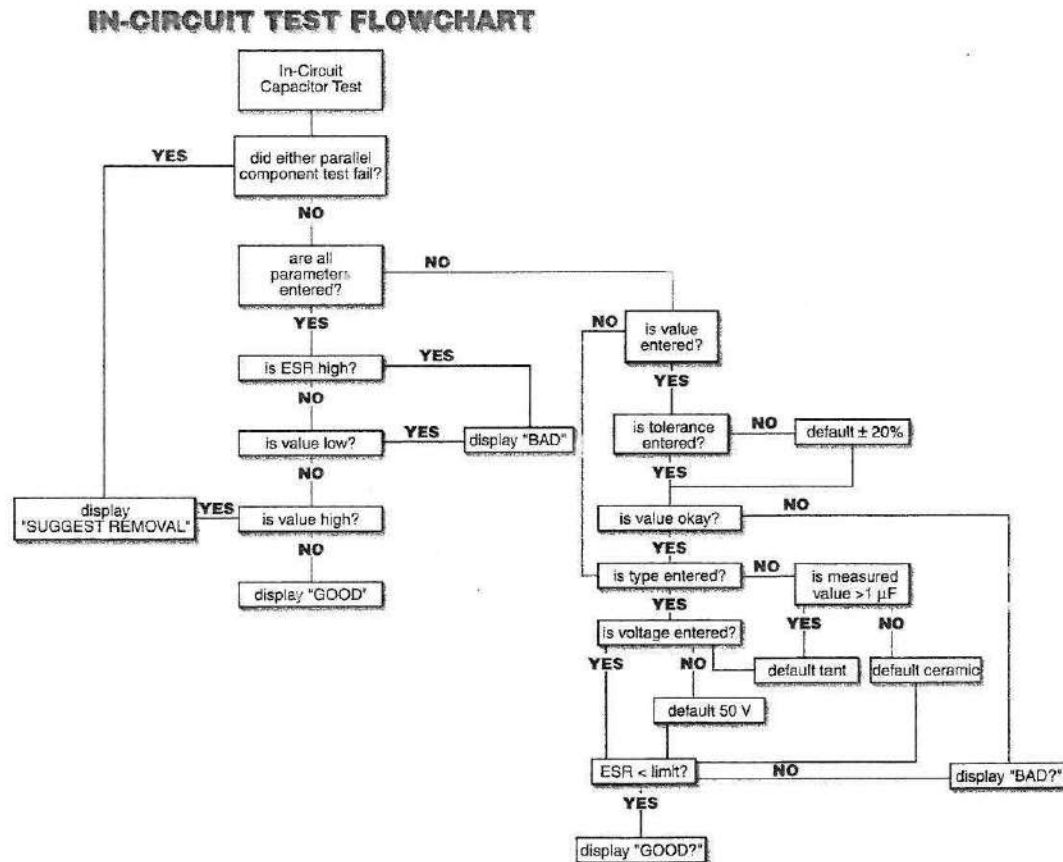

Fig. 29: In-Circuit Capacitor Test flow chart.



or BAD if they do not. If not all of the parameters are entered the LC103 checks to see which, if any, are. Depending on which parameters are entered the LC103 sets different defaults to which it compares the capacitor under test. If none of the component parameters are entered the LC103 defaults to tantalum for measured values above 1 uF and ceramic for measured values below 1 uF. The tolerance will default to +/-20% and the voltage will be 50 V. These defaults do not appear in the display and are only used by the LC103 determine if it will display "GOOD???" or "BAD???"

### Testing Non-Polarized (Bi-Polar) Electrolytics

Non-polarized aluminum electrolytic capacitors typically look very similar to standard aluminum electrolytics except for the polarity marking. Non-polarized electrolytics are typically used in circuits having no DC voltage or established polarity. Two common circuits that use non-polarized electrolytics are audio crossovers and AC motor start circuits. These circuits use non-polarized electrolytics for filtering or inducing phase shifts.

### Checking Leakage Between Sections Of A Multi-Section Lytic

Multiple section aluminum electrolytic capacitors are common, especially in many older power supplies. Such capacitors are actually several capacitors inside one can sharing the same negative terminal.

Leakage sometimes develops between one or two sections of multi-section lytics. This leakage is especially difficult to troubleshoot without the LC103 leakage test because signals from one section of the capacitor are coupled to another section. This results in multiple symptoms in the operation of the device in which the capacitor is used. An ohmmeter will not show leakage between sections of a multi-section cap because the leakage only occurs near the capacitor's operating voltage.

To isolate this type of leakage with the LC103 you simply perform the standard leakage test. As you test each section, short each of the remaining sections to ground. Any increase in leakage when a section is shorted to ground indicates leakage between sections.

#### WARNING

This test should only be performed by a person who understands the shock hazard of up to 1000 volts applied to the test leads during the capacitor leakage test. DO NOT hold the capacitor in your hand, or touch the test leads or capacitor leads when making this leakage test.

#### ATTENTION

Le LC103 est fait pour être utilisé par une personne qui est techniquement capable et qui comprend les chocs que peut produire l'équipement (jusqu'à 1000 V) lorsque le test de fuite est utilisé. NE PAS tenir la capacité dans la main ou toucher la sonde ou la patte de la capacité pendant le test de fuite.

To check for leakage between sections of a multi-section capacitor:

1. Connect one section of the capacitor to the LC103 test leads. Be sure to observe proper polarity.
2. Enter the working voltage of the section being tested.  
*NOTE: A multi-section lytic may have a different working voltage for each section.*
3. Press the CAPACITOR LEAKAGE button and read the amount of leakage on the display. It must be within the maximum allowable leakage limits for its value and voltage rating.
4. Connect one end of a short jumper to the common terminal of the capacitor.
5. While pressing the CAPACITOR LEAKAGE button, connect the other end of the jumper to each of the capacitor terminals not already connected to the LC103 test leads.
6. A good multi-section electrolytic will show no increase in the leakage as the jumper is connected to each terminal.

### Dielectric Stress

Many ceramic capacitors change value when they are DC biased. The applied DC voltage causes physical stress within the ceramic dielectric, causing it to decrease in value. This value change is called "dielectric stress." Normally a ceramic capacitor will return to its normal value within several seconds after the voltage is removed.

You will not normally notice dielectric stress when checking a ceramic capacitor with the ReZolver, unless you apply a voltage to it with the capacitor leakage test. Then you may find that the capacitance value has decreased by as much as 50% in ceramic capacitors having values 10 pF or smaller. This is a normal characteristic of small value ceramics.

### Intermittent Capacitors

Occasionally an electrolytic capacitor may become intermittent. A poor weld of the lead to the internal foil plates or other mechanical problem can cause the capacitor to function randomly. Often such capacitors will also exhibit high ESR when they are working. (The internal construction of an electrolytic capacitor is shown in the APPENDIX).

If you suspect an intermittent capacitor, move its leads around and pull on them as you perform a capacitor value test. A change in capacitance indicates an intermittent component which should be replaced.

### Checking Ceramic Capacitor Temperature Characteristics

Ceramic capacitors are designed to have a wide range of capacitance value and temperature characteristics, (More details are given in the APPENDIX.) Replacing a capacitor with one that has the same characteristics is especially important in certain oscillators and other temperature critical circuits. You can quickly determine the basic temperature characteristics of a ceramic using the LC103 and a heat source, such as a heat gun.



Simply connect the capacitor to the LC103 and measure its value. Then apply heat to the capacitor while you continue to measure its value. A COG or NPO type capacitor will not

change in value, or change very slightly as heat is applied. An N type ceramic will decrease in value, while a P type ceramic will increase in capacitance.

## INDUCTOR TESTING

### In-Circuit Inductor Test

The LC103 ReZolver can be used to measure the inductance of a coil with the component still in circuit. The actual measurement test is very similar to the out-of-circuit test except for an additional parallel component check. This check is done automatically when the in-circuit test is activated. If this test fails the LC103 will return a measured value along with a "SUGGEST REMOVAL" message. If the parallel component check passes, the ReZolver will measure the true inductance of the coil by measuring the counter EMF produced as a changing current is applied.

### Mutual Inductance

Mutual inductance occurs when two or more coils are wound on the same form and connected together. In such cases, the total inductance measured across the windings will not equal the sum of the measured inductances of the individual coils. This is due to the mutual inductance of the coils. The total measured value may be higher or lower than the individual inductances, depending on whether the coils are aiding or opposing. In addition, the effects of mutual inductance depend on the type of core material, the spacing of the turns, and the type of turns used. The amount of inductance measured by the ReZolver will be the same inductance seen by the circuit.

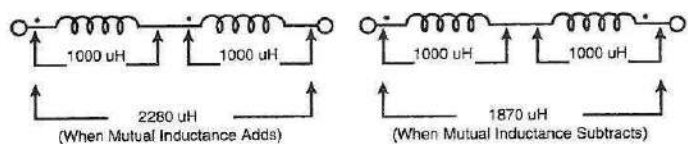

**Fig. 30:** The effects of mutual inductance may add or subtract from the sum of the individual.

### Ringling Peaking Coils

Peaking coils are often wound around a resistor. The resistor serves to lower the Q of the coil to prevent ringling. For this reason, some good peaking coils will not read good on the INDUCTOR RINGER test. The lower the resistor value, the fewer rings the coil will read.

The best test for peaking coils is to observe the number of rings, rather than the GOOD/BAD indication, and compare the coil to an identical known good component.

### Ringling Metal Shielded Coils

Sometimes coils, such as IF transformers, may be placed

inside a shield to reduce in-circuit interference. These shielded coils may not ring good when tested with the INDUCTOR RINGER test because the metal shield absorbs some of the ring energy. A shielded coil is good if it rings ten or more. However, if it rings less than ten, remove the metal shield, if possible, and test the coil again. If it now rings 10 or more, the coil is good. If you are unable to remove the metal shield, make a comparison test using an identical, known good component.

### Testing Flyback Transformers and Deflection Yokes

A flyback transformer is a special type of transformer which produces the focus and second anode voltages for a CRT. Many flybacks also have several lower voltage, relatively high current windings which power other circuits and the CRT filament. Because of the high voltages present, a flyback transformer may develop an internal shorted turn or leakage between windings. A shorted turn reduces the efficiency of the transformer and usually causes severe circuit problems. Inductance measurements are of little value when troubleshooting a flyback, since a shorted turn causes little change in inductance value. In addition, the inductance value is seldom known. The LC103 INDUCTOR RINGER test will detect a shorted turn in any of the primary or secondary windings of a flyback. Using the LC103's leakage supply, you can find any leakage between windings.

### Ringling Flyback Transformers

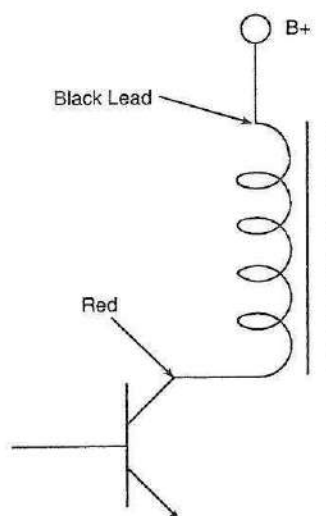

**Fig. 31:** Connect to the primary side of a flyback to do the ringling test.

A flyback transformer may be tested in or out of circuit with the LC103 Ringer test, although several external loads may need to be disconnected before a good flyback will produce



more than 10 rings. Connect the LC103 to the primary of the flyback and select the "YOKES & FLYBACKS" COMPONENT TYPE switch. Press and hold the Inductor Ringer test button and read the condition of the flyback as "GOOD" or "BAD" in the LC103 display. If the flyback rings "BAD", disconnect any loads until the display reads "GOOD." If the flyback is completely disconnected and still rings "BAD" the flyback has a shorted turn, or the winding to which the test leads are connected is open. In either case, the flyback should be considered bad.

*NOTE: Certain flybacks have removable cores. The ferrite core must be installed inside the windings in order for the flyback to ring "GOOD."*

A few flybacks used in some small solid state chassis have a low impedance primary which will not ring when good. However, these flybacks will always have a secondary winding which will ring good if the transformer is good. Simply ring the secondary windings. If one rings good the flyback does not have any shorted turns. If no winding rings good the flyback is bad.

A winding in the secondary of a flyback may occasionally open, rather than short. An open winding will not load the other windings as a short does. If the operation of the chassis indicates the possibility of an open winding, leave the LC103 connected to the primary winding and short each of the windings with a jumper. Shorting out a winding will reflect back to the primary and cause the ring test to go from "GOOD" to "BAD." If the ring test does not change, the winding being shorted with the jumper is open.

---

#### WARNING

---

**Do not connect the LC103 test leads to a flyback in-circuit until all power to the chassis has been removed, and the AC line cord has been disconnected.**

---

---

#### ATTENTION

---

**Ne pas connecter la sonde du LC103 à un transformateur en circuit avant de vous assurer que le châssis n'est plus sous tension et que le cordon secteur est déconnecté.**

---

#### To ring a flyback transformer:

1. Connect the test leads or probe across the primary winding of the flyback.
2. If the filament is powered by a scan derived supply disconnect the CRT socket board from the CRT to prevent the filaments from loading the secondary and giving a false ringing indication.
3. Press and hold the INDUCTOR RINGER test button. If the LC103 display reads "GOOD" the flyback is good, and the remaining steps are not necessary. A "BAD" reading indicates that either the flyback has a shorted turn or that it is being loaded down. The following steps will locate the defect. Continue disconnecting the loads

in the following order until the flyback rings "GOOD."

1. B+ supply
  2. Horizontal yoke
  3. Damper diode
  4. H.O.T. collector
  5. Scan derived supplies
4. If the flyback rings "GOOD" after you disconnect a load, the flyback does not have a shorted turn. If the flyback rings "GOOD" after disconnecting a scan derived supply, double check the components in that supply to make sure none of them are shorted or leaky.
  5. If all the loads are disconnected and the ringing test still indicates BAD, completely remove it from the circuit. If the flyback primary still rings less than 10, the flyback has a shorted turn and must be replaced.

#### Leakage Testing Flyback Transformers

In some cases, a flyback may develop a short or leakage from one winding to another or between a winding and the core or mounting bracket. Such a leakage path will often pull down the B+ supply. Sometimes this will be a zero resistance short that can be found with an ohmmeter, but many times the leakage only occurs when a higher voltage is applied. If the flyback passes the Ringer Test and you suspect possible leakage (the chassis draws excessive current, blows H.O.T.s, or shuts down) check the flyback using the LC103's LEAKAGE function. You should measure no leakage between separate windings or between any winding and the core or mounting bracket with 1000 volts applied. When checking an IHVT for leakage use both polarities of voltage to make sure the leakage path does not involve a diode.

*NOTE: Leakage between windings is different than a shorted turn. A Hi Pot test is needed to find leakage between windings. The Ringer test will find the more common shorted turn but will not find leakage or shorts between windings.*

#### To perform the flyback leakage test:

1. Completely remove the flyback from the chassis.
2. Connect the test leads across two separate windings.
3. Enter 1000 volts into the LC103.

*NOTE: You can select any type of capacitor or no component at all.*

4. Press and hold the LEAKAGE button and read the amount of leakage. It should drop to 0.0 uA. If the current does not drop to 0.0 uA the flyback is bad and should be replaced.
5. Repeat steps 3-5 for all combinations of windings.

Many flybacks have the high voltage rectifier diodes (tripler) built into the secondary winding. These flybacks are called Integrated High Voltage Transformers (IHVTs). The Ringing test will locate defective turns in these types of flybacks as well. A problem with the diodes will result in problems with the high voltage, even though the Ringing test indicates "GOOD." If the flyback rings "GOOD" but produces no high voltage, one of the diodes is open. If the



high voltage is several thousand volts too low and the flyback rings good, one or more of the diodes is shorted. In either case the flyback is defective and must be replaced.

### Ringling Deflection Yokes

Video deflection yokes are special inductors which are used to move a CRT electron beam both vertically and horizontally. As with flybacks, the LC103 Ringing test provides a quick and reliable GOOD/BAD test. Yokes should be tested while they are still mounted on the CRT, since a shorted winding may be caused by the pressure of the yoke mounting. Relieving the pressure may cause the short to go away.

A deflection yoke has two sets of windings (horizontal and vertical) which must both test good. The yoke leads must be disconnected from the circuit. This is often accomplished by simply pulling the yoke plug from the chassis. The vertical windings often have damping resistors across them which also must be disconnected. These resistors may be on the chassis, in which case simply pulling the yoke plug will disconnect them. They may also be soldered right to the yoke, meaning you will need to unsolder one side of the resistor. Test both yoke windings with the "YOKES & FLYBACK" COMPONENT TYPE button selected.

*NOTE: Test the vertical windings individually on yokes that have series connected vertical windings. The vertical windings should read within 3 rings of each other, but may not necessarily ring "GOOD" with 10 or more rings. Any such yoke that has a ring difference greater than 3 rings, or an inductance value difference greater than 10% will give problems in the chassis.*

#### WARNING

Do not connect the LC103 to the yoke in the chassis until all power has been removed and the AC plug has been disconnected.

#### ATTENTION

Ne pas connecter la sonde du LC103 à un tube en circuit avant de vous assurer que le châssis n'est plus sous tension et que le cordon secteur est déconnecté.

#### To test horizontal yoke windings:

1. Remove power from the chassis.
2. Disconnect the yoke from the circuit by pulling the yoke plug or unsoldering the wires.
3. Connect the test leads to the horizontal winding.
4. Select the "YOKES & FLYBACKS" COMPONENT TYPE button.
5. Press and hold the INDUCTOR RINGER test button and read the test result in the LC103 display.
6. If the ringer test result is 10 or more the horizontal yoke is good. If it rings less than 10, the horizontal yoke is defective.

#### To test the vertical windings:

1. Remove power from the chassis.
2. Disconnect the yoke from the circuit by pulling the yoke plug or unsoldering the wires.
3. If the yoke has damping resistors across the vertical winding, unsolder one end of the resistor.
4. Connect the test leads to the vertical winding.
5. Select the "YOKES & FLYBACKS" COMPONENT TYPE button.
6. Press and hold the INDUCTOR RINGER test button and read the test result in the LC103 display.
7. If the ringer test result is 10 or more the vertical yoke is good. If the vertical windings do not test "GOOD", try ringing each winding separately.

#### Special Note on Yokes and Flybacks:

A few yokes and flybacks have very low Q for use in certain solid state chassis. These components may not ring "GOOD" but may rather ring only 8 or 9 times. To determine if they are good or bad simply add a "shorted turn" and again check the number of rings. If the yoke or flyback is good, the number of rings will drop drastically when the short is added. A defective yoke or flyback will not be affected by the shorted turn and the number of rings will change only 1 or 2 counts if at all.

A simple "shorted turn" is a piece of solder or heavy gauge wire formed into a loop. Press the loop close to the windings of the yoke or wrap it around the core or windings of the flyback.

## TRANSMISSION CABLE TESTING

### Testing Coaxial Cable

Coaxial cables and transmission lines have characteristics of both an inductor and a capacitor, as illustrated in figure 32. The LC103 ReZolver can be used to determine the length of a piece of coaxial cable (or the distance to a break) and the distance to a short between the center conductor and shield. Any breakdown in the dielectric can also be detected using the LC103 leakage power supply.

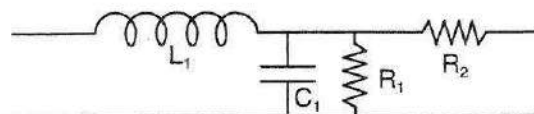

- $L_1$  = Series Inductance
- $C_1$  = Shunt Capacitance
- $R_1$  = Shunt Resistance (dielectric leakage)
- $R_2$  = Series Resistance

Fig. 32: A length of coaxial cable consists of capacitance and inductance distributed throughout the cable's length.



## Determining A Cable's Length or Distance To An Open

A length of coaxial cable open at both ends is equivalent to a long capacitor, with the two conductors forming the plates. Every type of coaxial cable has a normal amount of capacitance per foot, specified in picofarads per foot (pF/ft). The capacitance per foot values for some common coaxial cable types are listed in Table 12. The length of a piece of cable, as well as the distance to an open, is found by simply measuring the capacitance between the center and outer conductors and dividing this total capacitance by the cable's capacitance per foot value. If possible, measure from both ends of the cable to more accurately pinpoint the break. In most cases, the length of a cable can be determined within 1-2%.

### To measure the length of a cable:

1. Zero the LC103 test leads.
2. Connect the red test lead to the center conductor and the black test lead to the braided shield outer conductor of an open (unterminated) cable.
3. Press the CAPACITOR VALUE test button and read the total capacitance of the cable.
4. Divide the LC103 capacitance reading by the cable's capacitance per foot value. This gives the length of the cable, or the distance to the break in feet.

### 50-55 Ohm

RG/U Cable Type	Nominal Impedence	Nominal Cap in pF/FT	Nominal Inductance
5B/U	50	29.5	
8U	52	29.5	
8U Foam	50	26	
8A/U	52	29.5	
10A/U	52	29.5	
18A/U	52	29.5	
58/U	53.5	28.5	
58/U Foam	50	26	
58A/U	50	30.8	
58C/U	50	29.5	
58C/U Foam	50	26	
74A/U	52	29.5	
174/U	50	30-30.8	
177/U	50	30	
212/U	50	29.5	
213/U	50	30.5	
214/U	50	30.5	
215/U	50	30.5	
219/U	50	30	
225/U	50	30	
224/U	50	30	

### 70-75 Ohm

RG/U Cable Type	Nominal Impedence	Nominal Cap in pF	Nominal Inductance uH/FT
6A/U	75	20	
6A/U Foam	75	20	
11U	75	20.5	
11U Foam	75	17.3	
11A/U	75	20.5	
12A/U	75	20.5	
13A/U	74	20.5	
34B/U	75	20	
35B/U	75	20.5	
59/U	73	21	
59/U Foam	75	17.3	
59/BU	75	20.5	
164/U	75	20.5	
216/U	75	20.5	

### 90-125 Ohm

RG/U Cable Type	Nominal Impedence	Nominal Cap in pF	Nominal Inductance uH/FT
62/U	93	13.5	
62A/U	93	13.5	
63B/U	125	10	
71B/U	93	13.5	
79B/U	125	10	

You can also use this test to determine the length or to pinpoint a break in multi-conductor cable that has 3 or more conductors. Due to variations in conductor spacing and noise pickup, however, the accuracy will not be as good as for coaxial cable. Follow the same procedure as above except tie all but one of the conductors together to form the outer "shield." Measure the capacitance between this "shield" and the remaining single wire. You can determine the capacitance per foot for the cable using the procedure in the section "Determining Capacitance and Inductance Per Foot."

*NOTES: 1. The accuracy of these measurements depends on the cable tolerance. The values listed in Table 12 are nominal amounts which may vary slightly (within 2%) with cable manufacturer. 2. Excessive crimping or clamping along the cable will change the total capacitance reading.*

### Locating A Short In Coaxial Cable

A coaxial cable which has a short between its center conductor and outer conductor is similar to a very long inductor. The LC103 can be used to determine the distance to a short using the INDUCTOR VALUE test. The amount of inductance per foot of a coaxial cable is not usually published by the cable manufacturer, and the

Table 12 - Capacitance per foot values for common coaxial cable types.



amount for the same type of cable may vary significantly from one manufacturer to another. Therefore, to calculate the distance to a short you must first use a sample length of cable to determine the inductance per foot value, as explained in the following section. Record this amount in Table 12 for each type and manufacturer of cable you encounter.

#### To determine the distance to a short:

1. Zero the LC103 test leads.
2. Connect the red test lead to the center conductor and the black test lead to the braided shield outer conductor of a shorted cable.
3. Press the INDUCTOR VALUE test button and read the total inductance of the cable.
4. Divide the LC103 inductance reading by the cable's inductance per foot value. This gives the distance to the short in feet.

*NOTE: To help pinpoint the short with greater accuracy, measure the inductance from both ends of the cable.*

#### Determining Capacitance and Inductance Per Foot

The capacitance and inductance per foot values for a particular type of coaxial cable can be determined by measuring a sample cable of known length. After you measure the amount of capacitance and inductance with the LC103, simply divide the total amount by the length of the sample. A sample length of at least 10 feet is recommended for an accurate capacitance measurement, and 25 feet for accurate inductance measurement.

#### To determine capacitance and inductance per foot:

1. Zero the LC103 test leads.
2. Connect the red test lead to the center conductor and the black test lead to the braided shield outer conductor at one end of the sample cable.
3. Leave the other end of the cable open to measure capacitance. Short them together to measure inductance.
4. Press the CAPACITOR VALUE or INDUCTOR VALUE test button and read the total capacitance or inductance of the cable.
5. Divide the LC103 reading by the length of the sample cable.

#### Identifying Aging Cable

All coaxial cables eventually degrade to the point where they need to be replaced. The LC103 can be used for preventative maintenance checks of coaxial cable to determine if deterioration is beginning to occur. As a cable begins to fail, the dielectric separating the conductors becomes contaminated, causing a change in the cable's capacitance and the DC leakage through the dielectric.

All cable has a normal amount of capacitance per foot and any significant change that occurs over a period of time indicates a developing problem. The best check for aging cable is to measure and record the total capacitance of the installation when it is first installed. If the initial value is not known, you can multiply the length of the cable by its nominal capacitance per foot. Then compare periodic capacitance measurements back to the initial amount and look for any changes. As the dielectric becomes contaminated, the LC103 capacitance reading will increase.

The LC103 leakage power supply also provides a good test of a cable's condition. Simply measure the amount of leakage through the dielectric between the conductors. Most cables have a maximum operating voltage of 1000 volts or more and should be tested with the LC103 leakage supply set to 999.9 volts. A few "air space" dielectric types of coaxial cable, such as RG37, RG62, RG71, and RG72 have a maximum operating voltage of 750 volts and should be tested at this lower voltage.

---

#### WARNING

---

**This test should only be performed by a qualified person who understands the shock and safety hazards of up to 1000 volts applied to the test leads and open ends on the coaxial cable.**

---

---

#### ATTENTION

---

**Le LC103 est fait pour être utilisé par une personne qui est techniquement capable et qui comprend les chocs que peut produire l'équipement (jusqu'à 1000 V) à la sortie de la sonde ou du câble coaxial.**

---

A good piece of cable should have no leakage when the voltage from the LC103 is applied between the center conductor and outside shield. The length of the cable being tested will make no difference on the leakage reading. Any leakage reading indicates the dielectric is breaking down.



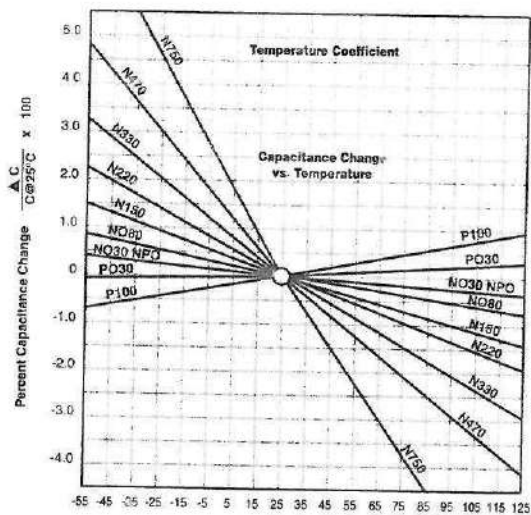

Fig. 39: Temperature change versus capacity change of P100 to N750 temperature compensated ceramic disc capacitors.

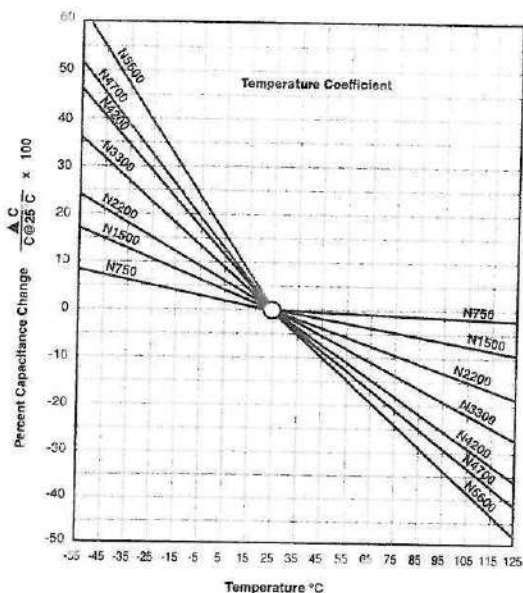

Fig. 40: Temperature change versus capacity change of N750 to N5600 temperature compensated ceramic disc capacitors.

type characteristics will have wider temperature variations and can vary both positive and negative with temperature changes. The Z5U probably has the greatest change and will only be found in non-critical applications such as B+ power supply decoupling. These type of capacitors should not be used in critical applications such as oscillator and timing circuits.

A ceramic capacitor marked GMV means that the value marked on the capacitor is the Guaranteed Minimum Value of capacity at room temperature. The actual value of the capacitor can be much higher. This type of capacitor is

used in bypass applications where the actual value of capacity is not critical.

Ceramic capacitors have been the most popular capacitors in electronics because of the versatility of the different temperature coefficients and the cost. When replacing a ceramic disc capacitor, be sure to replace the defective capacitor with one having the same characteristics and voltage rating.

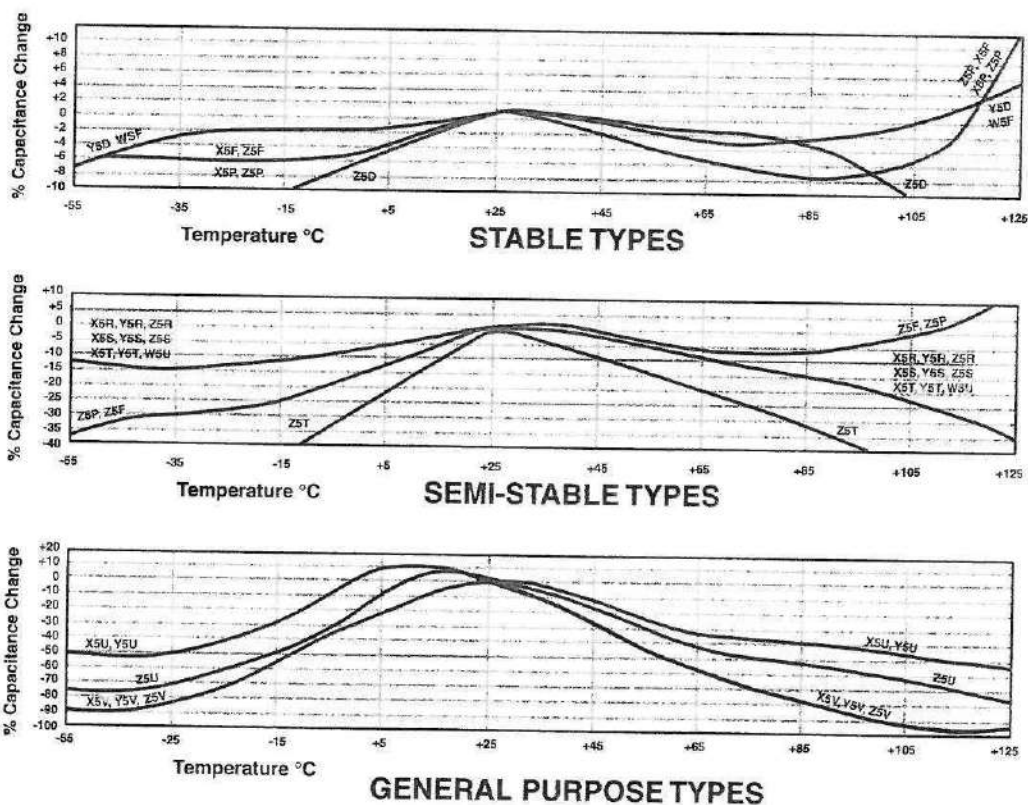

Fig. 41: Temperature change versus capacity change of non-temperature compensated ceramic disc capacitors.



## CAPACITOR FAILURE MODES

An ideal capacitor is defined as "a device consisting of two electrodes, separated by a dielectric, for introducing capacitance into an electric circuit." Unfortunately, we don't work with ideal components. The capacitors we encounter every day in our service work are much more complex than this simple definition. In an actual capacitor, a certain amount of current leaks through the dielectric or the insulation. Capacitors have internal series resistances, can exhibit an effect called dielectric absorption, and the capacitance can change in value. If we were to draw a circuit to represent an actual capacitor, it might look like the circuit in Figure 42.

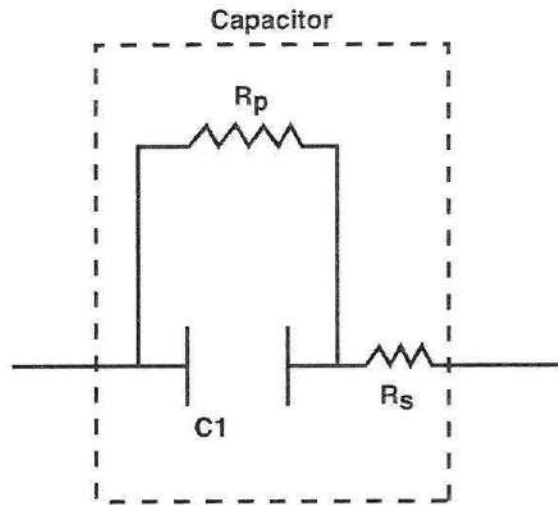

Fig. 42: Equivalent circuit of a practical capacitor.

The capacitor C1 represents the true capacitance, the resistance Rp represents the leakage path through the capacitor, and the resistance Rs, called the Equivalent Series Resistance (ESR) represents all of the combined internal series resistances in the capacitor.

### Value Change

Capacitors can change value. On some multi-layer foil capacitors, poor welding or soldering of the foil to the leads can cause an open to one of the foils to develop due to stress of voltage or temperature. This can result in a loss of almost one-half of the capacitor's marked capacity. Ceramic disc capacitors can also change value due to fissures or cracks. Small fissures or cracks in the ceramic insulating material can be created by thermal stress from exposure to heat and cold. Sometimes very small fissures develop which do not affect the capacitor until much later. Although the ceramic is still connected to the leads, the actual value of capacity could be a very small portion of the original value depending upon where the crack occurs. The ReZolver will let you know what the value of the capacitor is regardless of its marked value.

Electrolytic capacitors are another example of capacitors that can change value in circuit or on the shelf. As these capacitors dry out, they eventually lose their capacitance due to the failure of the aluminum oxide film making up the dielectric. A change in value in an aluminum electrolytic will often also be preceded by other defects, such as high leakage, high dielectric absorption and/or high internal resistance.

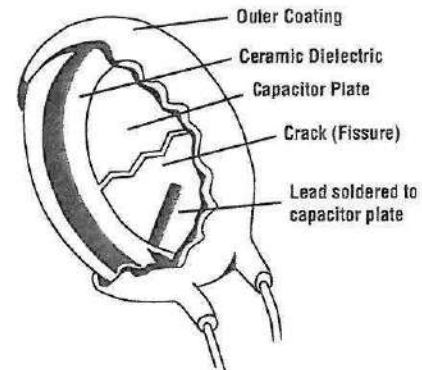

Fig. 43: A ceramic disc is made of a silver coated ceramic dielectric which is coated with a protective coating. Large cracks or fissures in the dielectric may develop which change the capacitance value.

### Equivalent Series Resistance (ESR)

Another problem which develops in capacitors is excessive Equivalent Series Resistance (ESR). All capacitors have a certain amount of ESR. Sources that contribute to ESR include lead resistance, dissipation in the dielectric material, and foil resistance. Small, non-electrolytic capacitors should have extremely small amounts of ESR. An electrolytic capacitor which has excessive ESR will develop internal heat which greatly reduces the life of the capacitor. In addition, ESR changes the impedance of the capacitor in circuit since it has the same effect as adding an external resistor in series with the component.

As Figure 44 shows, the ESR is the combined resistances of the connecting leads, the electrode plates, the resistance of the lead to plate connections, and the losses associated with the dielectric. All capacitors have some ESR. Normal amounts of ESR are tolerated by the capacitor and the circuit it is used in. Defects can occur, however, in the capacitor which will increase the ESR in the capacitor. Any increase in ESR can affect the circuit in which the capacitor is used, as well as the capacitor itself.

Excessive ESR causes heat to build up within the capacitor, causing it to fail at an accelerated rate. ESR also reduces the ability of a capacitor to filter AC. As the model in Figure 45 shows, the series resistance RS isolates the capacitor from the AC it is to filter.



**Impedance** – the total opposition of a circuit to the flow of an alternating or pulsating current.

**Insulation Resistance** – the ratio of the DC working voltage and the resulting leakage current through the dielectric. Generally a minimum value is specified, usually in the several thousand megohms range.

**Iron Core** – the central portion of a coil or transformer. Can be a powdered iron core as in small coils used in RF to the large iron sheets used in power transformers.

**Leakage Current** – stray direct current flowing through the dielectric or around it in a capacitor when a voltage is applied to its terminals.

**Metalized Capacitor** – one in which a thin film of metal has been vacuum plated on the dielectric. When a breakdown occurs, the metal film around it immediately burns away. Sometimes called a self-healing capacitor.

**Monolithic Ceramic Capacitor** – a small capacitor made up of several layers of ceramic dielectric separated by precious metal electrodes.

**Mutual Inductance** – the common property of two inductors whereby the induced voltage from one is induced into the other. The magnitude is dependent upon the spacing.

**NPO** – an ultra stable temperature coefficient in a ceramic disc capacitor. Derived from “negative-positive-zero”. Does not change capacity with temperature changes.

**Padder** – a high capacity variable capacitor placed in series with a fixed capacitor to vary the total capacity of the circuit by a small amount.

**Power Factor** – the ratio of the effective resistance of a capacitor to its impedance.

**Reactance** – the opposition of a capacitor or inductor to the flow of an AC current or a pulsating DC current.

**Self-Healing** – term used with metalized foil capacitors.

**Solid Tantalum Capacitor** – an electrolytic capacitor with a solid tantalum electrolyte instead of a liquid. Also called a solid electrolyte tantalum capacitor.

**Surge Voltage** – the maximum safe voltage in peaks to which a capacitor can be subjected to and remain within the operating specifications. This is not the working voltage of the capacitor.

**Temperature Coefficient (TC)** – the changes in capacity per degree change in temperature. It can be positive,

negative, or zero. Expressed in parts per million per degree Celsius for linear types. For non-linear types, it is expressed as a percent of room temperature.

**Time Constant** – the number of seconds required for a capacitor to reach 63.2% of its full charge after a voltage is applied. The time constant is the capacity in farads times the resistance in ohms expressed in seconds ( $T = RC$ ).

**Trimmer** – a low value variable capacitor placed in parallel with a fixed capacitor of higher value so that the total capacity of the circuit may be adjusted to a given value.

**Variable Capacitor** – a capacitor that can be changed in value by varying the distance between the plates or the useful area of its plates.

**Voltage Rating** – see working voltage.

**Wet (slug) Tantalum Capacitor** – an electrolytic capacitor having a liquid cathode.

**Working Voltage** – the maximum DC voltage that can be applied to a capacitor for continuous operation at the maximum rated temperature.







NOTES

---

Lined area for notes, consisting of multiple horizontal lines.