

Smart Instruments™
The new product family
from
Rohde & Schwarz

Operating Manual

Spectrum Analyzer with Tracking Generator R&S®FS3 I 5

Order No. 1147.1000.03



ROHDE & SCHWARZ

© Copyright 2005

ROHDE & SCHWARZ GmbH & Co. KG
Test and Measurement Division
Mühl Dorfstraße 15
81671 München, Germany

1st edition 08/2005
Printed in Germany.
Printed on FFC bleached paper.

Subject to alterations, Errors excepted.
Reprints, also in extracts, are only allowed with written permission of the manufacturer.
All rights reserved.

Chapter Overview

General	Content of the Manual for Spectrum Analyzer R&S FS315 Data Sheet Safety Instructions Certificate of Quality EC Certificate of Conformity Customer Support List of Rohde & Schwarz Offices
----------------	--

Chapter 1	Introduction
------------------	---------------------

Chapter 2	Control Elements
------------------	-------------------------

Chapter 3	Putting the R&S FS315 into Operation
------------------	---

Chapter 4	Getting Started
------------------	------------------------

Chapter 5	Manual Operating Concept
------------------	---------------------------------

Chapter 6	Using the R&S FS315
------------------	--------------------------------

Chapter 7	Remote Control/PC Software R&S FS315-K1
------------------	--

Chapter 8	Instrument Interfaces
------------------	------------------------------

Chapter 9	Error Messages
------------------	-----------------------

Chapter 10	Index
-------------------	--------------

Content of the Manual

Operating Manual

Introduction

This operating manual provides information about:

- Technical characteristics of the instrument
- Putting into operation
- Basic operating procedures and control elements
- Operation via menus and remote control

By way of an introduction, a typical R&S FS315 measurement is described.

The operating manual also contains information about maintenance and troubleshooting based on the warnings and error messages issued by the instrument.

Table of Contents

Chapter Overview	0-3
Content of the Manual	0-4
Operating Manual	0-4
Table of Contents	0-5
Data Sheet	0-12
Frequency.....	0-12
Level	0-13
Trigger	0-15
Tracking Generator.....	0-15
Inputs	0-16
Outputs	0-16
Interfaces	0-17
General Data	0-17
Safety Instructions	0-18
Certificate of Quality	0-21
EC Certificate of Conformity	0-22
Customer Support	0-23
List of Rohde & Schwarz Offices	0-24
1 Introduction	1-33
1.1 Applications for the R&S FS315.....	1-33
1.2 Supplied Accessories	1-34
1.3 Warranty	1-34
2 Control Elements	2-35
2.1 Front View	2-35
2.2 Rear View.....	2-36
3 Putting the R&S FS315 into Operation	3-37
3.1 Unpacking the R&S FS315.....	3-37
3.2 Setting up the Instrument	3-37
3.3 Connecting the R&S FS315 to the AC Line.....	3-39
3.4 Switching On the R&S FS315.....	3-39
3.5 Function Test	3-40
3.6 EMC.....	3-40
3.7 Connecting an External Keyboard.....	3-41
3.8 Connecting a USB Stick.....	3-42

4	Getting Started.....	4-43
4.1	Level and Frequency Measurements.....	4-43
4.1.1	Measurement Task.....	4-43
4.1.2	Measurement Procedure.....	4-44
4.2	Measuring the Frequency Response of a Twoport.....	4-45
4.2.1	Measurement Task.....	4-45
4.2.2	Measurement.....	4-45
5	Manual Operating Concept.....	5-47
5.1	Making Entries from the Keypad.....	5-47
5.1.1	Numerical Keys.....	5-47
5.1.2	Unit Keys.....	5-47
5.1.3	Rotary Knob.....	5-48
5.1.4	Cursor Keys.....	5-48
5.1.5	Function Keys.....	5-48
5.1.6	Action Keys.....	5-49
5.1.7	BACK/SYS Key.....	5-49
5.2	Screen Display.....	5-50
5.2.1	Diagram Area.....	5-51
5.2.2	Menu Area.....	5-52
5.2.3	Function Area.....	5-52
5.3	Calling and Changing Menus.....	5-53
5.4	Setting Parameters.....	5-55
5.4.1	Direct Selection of Instrument Functions.....	5-55
5.4.2	Selecting Settings.....	5-56
5.4.3	Entering Numerical Parameters.....	5-57
5.4.3.1	Entry with the Numerical Keys.....	5-57
5.4.3.2	Entry using the Cursor Keys and the Rotary Knob.....	5-59
5.5	Overview of all Menus and Functions.....	5-61
5.5.1	Spectrum Analyzer.....	5-61
5.5.1.1	FREQ/SPAN Menu.....	5-61
5.5.1.2	AMPT Menu.....	5-62
5.5.1.3	MKR Menu.....	5-62
5.5.1.4	BW/SWEEP Menu.....	5-64
5.5.1.5	TRACE Menu.....	5-65
5.5.1.6	TRIG Menu.....	5-65
5.5.1.7	MEAS Menu.....	5-66
5.5.2	SYSTEM Functions.....	5-68
5.5.2.1	PRESET Menu.....	5-68
5.5.2.2	STATUS Menu.....	5-68
5.5.2.3	FILE Menu.....	5-68
5.5.2.4	CONFIG Menu.....	5-68
5.5.2.5	SERVICE Menu.....	5-69
5.5.2.6	INFO Menu.....	5-69

6	Using the R&S FS315	6-70
6.1	R&S FS315 Factory Settings	6-70
6.2	Spectrum Analyzer	6-71
6.2.1	Selecting the Frequency Span (FREQ/SPAN Menu)	6-72
6.2.1.1	Entering the Center Frequency	6-73
6.2.1.2	Frequency-Axis Display Modes	6-74
6.2.1.2.1	Entering the Span	6-75
6.2.1.2.2	Displaying the Whole Frequency Range	6-76
6.2.1.2.3	Switching over to the ZERO SPAN	6-77
6.2.1.2.4	ZOOM Functions	6-78
6.2.1.3	Entering the Start Frequency and the Stop Frequency	6-79
6.2.1.4	Entering the Step Width of the Center Frequency	6-80
6.2.1.4.1	Setting the Step Size	6-81
6.2.1.5	Activating Signal Tracking	6-82
6.2.2	Setting the Level Axis and the RF Input (AMPT Menu)	6-83
6.2.2.1	Entering the Reference Level	6-84
6.2.2.2	Entering a Level Offset	6-85
6.2.2.3	Selecting the Level Display Range	6-86
6.2.2.4	Selecting the Level Display Unit	6-87
6.2.2.5	Setting the RF Input Attenuation Manually	6-89
6.2.2.6	Setting the RF Input Attenuation Automatically	6-90
6.2.2.7	Selecting the Setting High Sensitivity	6-92
6.2.3	Signal Analysis using Marker Functions (MKR Menu)	6-93
6.2.3.1	Activating Marker 1	6-94
6.2.3.1.1	Reading off Measured Values with Marker 1	6-95
6.2.3.1.2	Frequency Measurements using the Frequency Counter	6-97
6.2.3.2	Activating Marker 2	6-98
6.2.3.2.1	Reading off Measured Values with Marker 2	6-99
6.2.3.2.2	Reading off Level Differences	6-100
6.2.3.3	Accepting Marker Values as Settings	6-101
6.2.3.3.1	Moving Trace Sections in the Measurement Diagram	6-102
6.2.3.3.2	Setting the Step Size to the Marker Frequency	6-104
6.2.3.4	Marker Measurement Functions	6-105
6.2.3.4.1	Measuring the Noise Power Density	6-106
6.2.3.4.2	Measuring the Filter or Signal Bandwidth	6-108
6.2.3.5	Activating a Display Line	6-110
6.2.3.6	Setting the Search Criterion of Functions NEXT PEAK LEFT/RIGHT	6-111
6.2.3.6.1	Entering the Peak Excursion	6-112
6.2.3.7	Setting Reference Points for Level-Difference Measurements	6-114
6.2.3.7.1	Manual Entry of Reference Points	6-115
6.2.4	Setting the Bandwidths and the Sweep Time (BW/SWEEP Menu)	6-118
6.2.4.1	Setting the Resolution Bandwidth	6-119
6.2.4.2	Setting the Video Bandwidth	6-120
6.2.4.3	RBW, VBW and SPAN Coupling Ratio	6-121
6.2.4.3.1	Changing the Coupling Ratio RBW/VBW	6-122
6.2.4.3.2	Switching Over the Coupling RBW/SPAN to Low Noise	6-123
6.2.4.4	Setting the Sweep	6-124
6.2.4.4.1	Selecting the Frequency Sweep	6-125
6.2.4.4.2	Setting the Sweep Time	6-126

6.2.4.5	Evaluating the Individual Pixels of a Trace	6-128
6.2.4.5.1	Selecting the Detector	6-129
6.2.5	Measured-Value Display (TRACE Menu).....	6-131
6.2.5.1	Selecting the Active Trace.....	6-132
6.2.5.1.1	Activating Traces	6-133
6.2.5.2	Displaying the Active Trace.....	6-135
6.2.5.3	Trace Difference Function.....	6-138
6.2.5.3.1	Activating the Trace Difference Function.....	6-139
6.2.6	Triggering Measurements (TRIG Menu).....	6-140
6.2.6.1	Internal Trigger Sources.....	6-141
6.2.6.2	External Trigger Sources.....	6-142
6.2.6.3	Setting a Trigger Offset	6-142
6.2.7	Measurement Functions (MEAS Menu)	6-143
6.2.7.1	Measuring the Power in the Time Domain	6-144
6.2.7.1.1	Measuring the Power.....	6-145
6.2.7.2	Measuring the Channel Power	6-148
6.2.7.2.1	Measuring the Channel Power	6-149
6.2.7.2.2	Measuring the Occupied Bandwidth.....	6-151
6.2.7.3	Configuring the Built-In Generator	6-152
6.2.7.3.1	Selecting the Operating Mode	6-154
6.2.7.3.2	“Tracking Generator” Mode	6-154
6.2.7.3.3	“Freq Fixed” Mode	6-159
6.2.7.4	AM/FM Demodulation.....	6-160
6.2.7.4.1	Demodulating Signals.....	6-161
6.2.7.5	Measuring the Third-Order Intercept Point.....	6-162
6.2.7.6	Activating the Transducer Function.....	6-164
6.2.7.6.1	Using Transducer Sets	6-165
6.3	SYSTEM Functions (BACK/SYS Key).....	6-167
6.3.1	Instrument Default Setting (Menu PRESET)	6-169
6.3.1.1	Selecting and Calling the Instrument Default Setting.....	6-170
6.3.2	Displaying the Current Instrument Setting (STATUS Menu).....	6-171
6.3.2.1	Spectrum Analyzer Settings	6-172
6.3.2.2	Settings for the Channel Power Measurement	6-173
6.3.2.3	Tracking Generator Settings	6-174
6.3.2.4	Demodulation Settings	6-175
6.3.2.5	Settings for Transducer Sets.....	6-176
6.3.3	User-Defined Settings (FILE Menu)	6-177
6.3.3.1	Saving and Loading User-Defined Settings	6-178
6.3.3.2	Printing out a Screenshot.....	6-180
6.3.4	System Settings (CONFIG Menu)	6-184
6.3.4.1	Setting the Date and Time of Day	6-185
6.3.4.2	Selecting an Internal or External Reference Source.....	6-187
6.3.4.3	Configuring the Instrument Interfaces	6-188
6.3.4.4	Setting the Screen Saver Mode	6-190
6.3.4.5	Selecting an Internal or External Monitor	6-193
6.3.5	Service Functions (SERVICE Menu).....	6-194
6.3.5.1	Performing Selftests	6-194
6.3.6	System Information (INFO Menu).....	6-195

6.3.6.1	Displaying Module Data	6-196
6.3.6.2	Displaying Instrument Statistics	6-196
6.3.6.3	Displaying System Messages	6-197
7	Remote Control/PC Software R&S FS315-K1	7-199
7.1	Applications of PC Software	7-199
7.2	Installation and Configuration.....	7-200
7.2.1	Installing the PC Software	7-200
7.2.1.1	Installing the Program	7-200
7.2.1.2	Installing the Device Drivers.....	7-203
7.2.1.2.1	Installing Steps for Windows™ 2000	7-203
7.2.1.2.2	Installing Steps for Windows™ XP.....	7-207
7.2.2	Connecting the PC-Software with the R&S FS315.....	7-211
7.2.2.1	Starting the Series 300 Software Manager	7-211
7.2.2.2	Creating the Program Version.....	7-212
7.2.3	Uninstalling the PC Software	7-213
7.2.4	Update PC Software	7-214
7.3	Starting the Remote Control.....	7-216
7.3.1	Connecting the Instrument to the PC.....	7-216
7.3.2	Starting the Program.....	7-217
7.3.3	Closing the Remote Control.....	7-219
7.4	Getting Started.....	7-219
7.4.1	Level and Frequency Measurement	7-219
7.4.1.1	Measuring Task.....	7-219
7.4.1.2	Measuring Sequence	7-220
7.5	Control Concept.....	7-222
7.5.1	PC Monitor Display	7-222
7.5.1.1	Diagram.....	7-223
7.5.1.2	Menus.....	7-224
7.5.1.3	Functions.....	7-225
7.5.2	Input via Keyboard and Mouse	7-226
7.5.2.1	Numeric Keys	7-226
7.5.2.2	Arrow Keys	7-226
7.5.2.3	Function Keys.....	7-227
7.5.2.4	Action Keys (Enter, Esc)	7-228
7.5.2.5	Tab Key	7-228
7.5.2.6	Space Key	7-228
7.5.2.7	Mouse Buttons.....	7-229
7.5.3	Calling up and Changing the Menus	7-230
7.5.4	Setting the Parameters	7-231
7.5.4.1	Direct Selection of a Instrument Function	7-231
7.5.4.2	Selecting the Settings.....	7-232
7.5.4.3	Inputting the Numerical Parameters.....	7-232
7.5.4.4	Moving the Markers.....	7-234
7.6	Overview of all Menus and Functions (Shortcuts).....	7-234

7.6.1	File	7-234
7.6.2	Function	7-235
7.6.2.1	FREQ Menu.....	7-236
7.6.2.2	Amp Menu	7-237
7.6.2.3	Marker Menu	7-238
7.6.2.4	BW/Sweep Menu.....	7-240
7.6.2.5	Trace Menu	7-241
7.6.2.6	Trigger Menu	7-242
7.6.2.7	Measure Menu.....	7-243
7.6.3	View	7-245
7.6.4	? Help.....	7-245
7.6.5	Zoom Functions	7-245
7.7	Saving/Exporting Data (File).....	7-246
7.7.1	Opening the Session	7-246
7.7.1.1	Beginning New Measurement	7-246
7.7.1.2	Loading the Saved Settings	7-247
7.7.2	Saving the Session	7-248
7.7.3	Monitoring the Measuring Values	7-249
7.7.3.1	Inserting the Limit Lines	7-249
7.7.3.2	Monitoring.....	7-252
7.7.3.3	Analyzing the Logfile	7-254
7.7.4	Exporting the Measuring Data	7-255
7.7.4.1	Creating the ASCII File.....	7-255
7.7.4.2	Creating the Screenshot.....	7-256
7.7.5	Printing the Window.....	7-257
7.8	Transducer Factors	7-258
7.8.1	Creating Transducer List	7-260
7.8.2	Creating Transducer Set.....	7-263
7.8.3	Activating Transducer Factors	7-265
7.9	Customizing the Working Window (View)	7-266
7.9.1	Adjusting the Window Size	7-266
7.9.2	Changing the Window Color	7-267
7.10	Getting Help (?).....	7-268
7.10.1	Starting the Help	7-268
7.10.2	Displaying the Program Version	7-268
7.10.3	Displaying Module Data	7-269
8	Instrument Interfaces	8-270
8.1	Keyboard Connector (KEYB).....	8-270
8.2	Monitor Connector (MON).....	8-270
8.3	Input for External Trigger (EXT TRIG)	8-271
8.4	Reference Input and Output (REF IN and REF OUT)	8-271
8.5	USB Interface (PC, DEV)	8-271
8.6	Headphone Output (AF OUT)	8-271

9 Error Messages 9-272

9.1 System Messages 9-272

9.2 Warnings Indicating Impermissible Operating States 9-273

10 Index 10-275

Data Sheet

**Note**

For the R&S FS315 a calibration cycle of 1 year is recommended.

Frequency

Frequency range		9 kHz to 3 GHz
Frequency resolution		0.1 Hz
Reference frequency		10 MHz, nominal
Aging		2×10^{-6} /year
Temperature drift	5° C to 30° C	1×10^{-6}
External reference		10 MHz
Frequency counter		
Resolution		1 Hz, 10 Hz
Count accuracy	S/N > 25 dB	± (marker frequency x reference error + ½ (last digit))
Frequency span		1 kHz to 3 GHz, 0 Hz
Span accuracy		< 1 %
Spectral purity		
SSB phase noise	$9 \text{ kHz} \leq f \leq 3 \text{ GHz}$	
	10 kHz carrier offset	< -90 dBc (1Hz), -95 dBc (1Hz) typ.
	100 kHz carrier offset	-100 dBc (1Hz) typ.
	1 MHz carrier offset	-110 dBc (1Hz) typ.
Residual FM	RBW 1 kHz, VBW 1 kHz $9 \text{ kHz} \leq f \leq 3 \text{ GHz}$, weighting to CCITT	< 100 Hz
Sweep time		
Span > 1 kHz		30 ms to 1000 s
Max. deviation		1 %
Span = 0 Hz		5 μs to 10 s
Resolution		20 ns

Bandwidths		
Resolution bandwidths (-3 dB)	in 1, 2, 3, 5 sequence	200 Hz to 20 MHz
Bandwidth accuracy		
	RBW \leq 1 MHz	< 1 %
	2 MHz \leq RBW \leq 10 MHz	< 5 %
	RBW 10 MHz, 20 MHz	< 10 %
Shape factor 60 dB/3 dB	RBW \leq 3 MHz	< 4.6:1
Video bandwidths	In 1/2/3/5 sequence	10 Hz to 20 MHz

Level

Display range		displayed average noise level to + 33 dBm
Display scaling		80 dB, 40 dB, 16 dB, 8 dB, linear
Display units		
Logarithmic		dBm, dB μ V, dBmV
Linear		V, W
Maximum input level		
DC voltage		30 V
	-30 V to 30 V step	1200 V/ μ s
CW RF power		
	RF attenuator < 20 dB	+13 dBm
	RF attenuator \geq 20 dB	
	50 MHz to 3 GHz	+33 dBm
	20 MHz to 50 MHz	+26 dBm
	9 kHz to 20 MHz	+20 dBm
1dB compression point of 1st mixer		
	RF attenuation 0 dB, f > 100 kHz	-10 dB, nominal
Linearity		
Harmonics	-40 dBm input level, RF attenuation 0 dB	< -60 dBc
Intermodulation-free dynamic range for third-order intermodulation	two-tone signal with level 2 x -30 dBm, RF attenuation 6 dB	< -70 dBc

Displayed average noise level		
	9 kHz to 3 GHz, RF attenuator 0 dB, RBW 300 Hz, VBW 10 Hz	< -110 dBm, typ. -115 dBm
Spurious		
Inherent spurious	RF attenuator 0 dB, input terminated	< -85 dBm
Other spurious	10 MHz to 3 GHz, level at 1 st mixer -35 dBm	< -60 dBc
Level settings		
Setting range of reference level		-110 dBm to +36 dBm
Resolution		0.1 dB
RF attenuation range	manual selection or automati- cally coupled to reference level	0 dB to 70 dB
Resolution		2 dB
Traces		1 active trace and 1 stored trace
Trace detectors		max peak, min peak, sample, average, RMS
Trace functions		clear/write, max hold, min hold, average
Max. uncertainty of level meas- urement		
Frequency response	9 kHz to 3 GHz, RF attenuation 0 dB to 70 dB	< 1.0 dB
Reference level accuracy		< 0.3 dB
Display nonlinearity		
	0 dB to -60 dB	< 0.3 dB
	-60 dB to -70 dB	< 1 dB
Bandwidth switching uncertainty		< 0.3 dB
Total measurement uncertainty	0 dB to -60 dB down from ref. level, RBW \leq 5 MHz	1.5 dB, typ. 0.7dB
Markers		
Number of markers and delta mark- ers		1 marker and 1 delta marker
Marker functions		peak, next peak left, next peak right, center = marker fre- quency, ref level = marker level
Marker displays		normal (level), noise marker, frequency counter, n-dB down (bandwidth)
Audio demodulation	zero-span only, RBW \leq 1 MHz	AM and FM

Trigger

Span \geq 1 kHz		
Trigger source		free run, external
Trigger offset	Sweep time > 100 ms	$0 \text{ s} \leq \text{Trigger offset} \leq 100 \text{ ms}$, resolution 25 ns
Span = 0 Hz		
Trigger source		free run, external, video
Trigger offset	negative offset limited by sweep time	$-100 \text{ ms} \leq \text{Trigger Offset} \leq 10 \text{ s}$, resolution 25 ns

Tracking Generator

Frequency		
Frequency range		9 kHz to 3 GHz
Frequency offset		
Setting range		0 Hz to 3 GHz
Resolution		0.1 Hz
Spectral purity		
SSB phase noise	10 kHz carrier offset $9 \text{ kHz} \leq f \leq 3 \text{ GHz}$	< -90 dBc (1Hz)
Level		
Level setting range		0 dBm to -50 dBm
Resolution		0.1 dB
Max. deviation of output level	9 kHz to 3 GHz, 20° C to 30° C, $50 \text{ kHz} \leq \text{RBW} \leq 3 \text{ MHz}$	< 1 dB
Spurious		
Harmonics	output level -10 dBm	< -20 dBc
Nonharmonics	output level 0 dBm	< -30 dBm

Inputs

RF input		
Connector		N female (front panel)
Input impedance		50 Ω
VSWR	RF attenuation 20 dB	< 1.5
LO radiation	RF attenuation 10 dB	< -50 dBm
External trigger input		
Connector		N female (front panel)
Voltage level		TTL
Reference frequency input		
Connector		BNC female (rear panel)
Reference frequency		10 MHz \pm 50 Hz
Impedance		50 Ω
Input level		0 dBm to 20 dBm

Outputs

RF out (tracking generator)		
Connector		N female (front panel)
Output impedance		50 Ω
VSWR		< 1.6
Reference frequency output		
Connector		BNC female (rear panel)
Reference frequency		10 MHz
Output impedance		50 Ω
Output level		7 dBm, nominal
AF output		
Connector		3.5 mm mini jack for headhhone (rear panel)
Output impedance		15 Ω

Interfaces

USB host	device-specific command set, remote control via supplied Windows driver (Windows XP/2000)	A plug, protocol version 1.1
USB device		B plug, protocol version 1.1
Connector for external monitor (VGA)		15-pin D-SUB female
Keyboard connector		PS/2 female

General Data

Display		
Type		5.4" active TFT color display
Resolution		320 x 240 pixels
Max. refresh rate		10 pictures/s, nominal
Power supply		
Input voltage range	autoranging	100 V to 240 V (AC) 50 Hz to 60 Hz
Power consumption		< 60 W
Ambient conditions		
Permissible temperature range	meets DIN EN 60068-2-1/2	+ 5° C to + 45° C
Storage temperature range		-20° C to + 70° C
Relative humidity	meets DIN EN 60068-2-3 (non-condensing)	95 % at + 40° C
Mechanical resistance		
Sinusoidal vibration	meets DIN EN 60068-2-6, DIN EN 61010-1 and MIL-T-28800D class 5	5 Hz to 150 Hz: max. 2g at 5 Hz, 55 Hz to 150 Hz: 0.5g constant
Random vibration	meets DIN EN 60068-2-64	10 Hz to 500 Hz: 1.9g
Shock	meets DIN EN 60068-2-27 and MIL-STD-810	shock spectrum
Electromagnetic compatibility	meets EN 55011 class B and EN 61326 (EMC Directive of EU (89/336/EEC))	
EMI field strength		10 V/m
Safety	DIN EN 616010-1/IEC61010-1 UL3111-1; CSA22.2 No:1010.1	
Dimensions (W x H x D)		219 mm x 147 mm x 350 mm
Weight		approx. 9 kg









Safety Instructions

 **Note**

This unit has been designed and tested in accordance with the EC Certificate of Conformity and has left the manufacturer's plant in a condition fully complying with safety standards.

To maintain this condition and to ensure safe operation, the user must observe all instructions and warnings given in this operating manual.

Safety-related symbols used on equipment and documentation from R&S

 <p>Observe operating instructions</p>	 <p>Weight indication for units > 18 kg</p>	 <p>PE terminal</p>	 <p>Ground terminal</p>
 <p>Danger! Shock hazard</p>	 <p>Warning! Hot surfaces</p>	 <p>Ground</p>	 <p>Attention! Electrostatic sensitive devices require special care</p>

Safety instructions

1. The unit may be used only in the operating conditions and positions specified by the manufacturer. Unless otherwise agreed, the following applies to R&S products:
IP degree of protection 2X, pollution severity 2 overvoltage category 2, only for indoor use, altitude max. 2000 m.
Unless specified otherwise in the data sheet, a tolerance of $\pm 10\%$ shall apply to the nominal voltage and of $\pm 5\%$ to the nominal frequency.
2. For measurements in circuits with voltages $V_{\text{rms}} > 30\text{ V}$, suitable measures should be taken to avoid any hazards (using, for example, appropriate measuring equipment, fusing, current limiting, electrical separation, insulation).
3. If the unit is to be permanently wired, the PE terminal of the unit must first be connected to the PE conductor on site before any other connections are made. Installation and cabling of the unit to be performed only by qualified technical personnel.
4. For permanently installed units without built-in fuses, circuit breakers or similar protective devices, the supply circuit must be fused such as to provide suitable protection for the users and equipment.
5. Prior to switching on the unit, it must be ensured that the nominal voltage set on the unit matches the nominal voltage of the AC supply network.
If a different voltage is to be set, the power fuse of the unit may have to be changed accordingly.
6. Units of protection class I with disconnectible AC supply cable and appliance connector may be operated only from a power socket with earthing contact and with the PE conductor connected.
7. It is not permissible to interrupt the PE conductor intentionally, neither in the incoming cable nor on the unit itself as this may cause the unit to become electrically hazardous.
Any extension lines or multiple socket outlets used must be checked for compliance with relevant safety standards at regular intervals.
8. If the unit has no power switch for disconnection from the AC supply, the plug of the connecting cable is regarded as the disconnecting device.
In such cases it must be ensured that the power plug is easily reachable and accessible at all times (length of connecting cable approx. 2 m). Functional or electronic switches are not suitable for providing disconnection from the AC supply.
If units without power switches are integrated in racks or systems, a disconnecting device must be provided at system level.
9. Applicable local or national safety regulations and rules for the prevention of accidents must be observed in all work performed.
Prior to performing any work on the unit or opening the unit, the latter must be disconnected from the supply network.
Any adjustments, replacements of parts, maintenance or repair may be carried out only by authorized R&S technical personnel.
Only original parts may be used for replacing parts relevant to safety (e.g. power switches, power transformers, fuses). A safety test must be performed after each replacement of parts relevant to safety (visual inspection, PE conductor test, insulation-resistance, leakage-current measurement, functional test).
10. Ensure that the connections with information technology equipment comply with IEC950/EN60950.

11. Lithium batteries must not be exposed to high temperatures or fire. Keep batteries away from children. If the battery is replaced improperly, there is danger of explosion. Only replace the battery by R&S type (see spare part list). Lithium batteries are suitable for environmentally-friendly disposal or specialized recycling. Dispose them into appropriate containers, only. Do not short-circuit the battery.
12. Equipment returned or sent in for repair must be packed in the original packing or in packing with electrostatic and mechanical protection.
13. Electrostatics via the connectors may damage the equipment. For the safe handling and operation of the equipment, appropriate measures against electrostatics should be implemented.
14. The outside of the instrument is suitably cleaned using a soft, lint-free dust-cloth. Never use solvents such as thinners, acetone and similar things, as they may damage the front panel labeling or plastic parts.
15. Any additional safety instructions given in this manual are also to be observed.

Certificate of Quality

Certified Quality System ISO 9001

DQS REG. NO 1954-04

Certificate of quality

Dear Customer,

You have decided to buy a Rohde & Schwarz product. You are thus assured of receiving a product that is manufactured using the most modern methods available. This product was developed, manufactured and tested in compliance with our quality management system standards.

The Rohde & Schwarz quality management system is certified according to ISO 9001.





Certificate No.: 2005-23

This is to certify that:

Equipment type	Stock No.	Designation
FS315	1147.1000.03	Spectrum Analyzer

complies with the provisions of the Directive of the Council of the European Union on the approximation of the laws of the Member States

- relating to electrical equipment for use within defined voltage limits (73/23/EEC revised by 93/68/EEC)
- relating to electromagnetic compatibility (89/336/EEC revised by 91/263/EEC, 92/31/EEC, 93/68/EEC)

Conformity is proven by compliance with the following standards:

EN61010-1 : 2001-12
 EN55011 : 1998 + A1 : 1999, Class B
 EN61326 : 1997 + A1 : 1998 + A2 : 2001

For the assessment of electromagnetic compatibility, the limits of radio interference for Class B equipment as well as the immunity to interference for operation in industry have been used as a basis.

Affixing the EC conformity mark as from 2005

ROHDE & SCHWARZ GmbH & Co. KG
 Mühldorfstr. 15, D-81671 München

Munich, 2005-06-07

Central Quality Management MF-QZ / Radde

1147.1000.03

CE

E-1

Customer Support

Technical support – where and when you need it

For quick, expert help with any Rohde & Schwarz equipment, contact one of our Customer Support Centers. A team of highly qualified engineers provides telephone support and will work with you to find a solution to your query on any aspect of the operation, programming or applications of Rohde & Schwarz equipment.

Up-to-date information and upgrades

To keep your Rohde & Schwarz equipment always up-to-date, please subscribe to an electronic newsletter at

<http://www.rohde-schwarz.com/www/response.nsf/newsletterpreselection>

or request the desired information and upgrades via email from your Customer Support Center (addresses see below).

Feedback

We want to know if we are meeting your support needs. If you have any comments please email us and let us know

CustomerSupport.Feedback@rohde-schwarz.com

Customer support center

USA & Canada

Monday to Friday (except US-state holidays)
8:00 AM – 8:00 PM Eastern Standard Time (EST)

USA: 888-test-rsa (888-837-8772) (opt 2)
From outside USA: +1 410 910 7800 (opt 2)
Fax: 410 910 7801

E-Mail: Customer.Support@rsa.rohde-schwarz.com

Rest of World

Monday to Friday (except German-state holidays)
08:00 – 17:00 Central European Time (CET)

Europe: +49 (0) 180 512 42 42
From outside Europe: +49 89 4129 13776
Fax: +49 (0) 89 41 29 637 78

E-Mail: CustomerSupport@rohde-schwarz.com

List of Rohde & Schwarz Offices

	HEADQUARTERS	Phone Fax E-mail
Germany	Rohde & Schwarz GmbH & Co. KG Mühlendorfstraße 15 · D-81671 München Postfach 801469 · D-81614 München	+49 (89) 4129-0 +49 (89) 4129-12164 -
	PLANTS	
	Rohde & Schwarz Messgerätebau GmbH Riedbachstraße 58 · D-87700 Memmingen Postfach 1652 · D-87686 Memmingen	+49 (8331) 108-0 +49 (8331) 108-11 24 -
	Rohde & Schwarz GmbH & Co. KG Werk Teisnach Kaikenrieder Straße 27 · D-94244 Teisnach Postfach 1149 · D-94240 Teisnach	+49 (9923) 850-0 +49 (9923) 850-11 74 -
	Rohde & Schwarz GmbH & Co. KG Dienstleistungszentrum Köln Graf-Zeppelin-Straße 18 · D-51147 Köln Postfach 98 02 60 · D-51130 Köln	+49 (2203) 49-0 +49 (2203) 49 51- 229 info@rsdc.rohde-schwarz.com service@rsdc.rohde-schwarz.com
	SUBSIDIARIES	
	Rohde & Schwarz Vertriebs-GmbH Mühlendorfstraße 15 · D-81671 München Postfach 80 14 69 · D-81614 München	+49 (89) 41 29-137 +49 (89) 41 29-137 77 -
	Rohde & Schwarz International GmbH Mühlendorfstraße 15 · D-81671 München Postfach 80 14 60 · D-81614 München	+49 (89) 41 29-129 84 +49 (89) 41 29-120 50 -
	ROHDE & SCHWARZ Europe GmbH Mühlendorfstraße 15, D-81671 München	+49(89) 41 29-137 11 +49 (89)4129-137 23 info.rse@rohde-schwarz.com
	Rohde & Schwarz Engineering and Sales GmbH Mühlendorfstraße 15 · D-81671 München Postfach 80 14 29 · D-81614 München	+49 (89) 41 29-137 11 +49 (89) 41 29-137 23 -
	R&S BICK Mobilfunk GmbH Fritz-Hahne-Str. 7 · D-31848 Bad Münder Postfach 2062 · D-31844 Bad Münder	+49 (5042) 998-0 +49 (5042) 998-105 -
	Rohde & Schwarz FTK GmbH Wendenschloßstraße 168, Haus 28 D-12557 Berlin	+49 (30) 658 91-122 +49 (30) 655 50-221 -
	R&S Systems GmbH Graf-Zeppelin-Straße 18 D-51147 Köln	+49 (22 03) 49-5 23 25 +49 (22 03) 49-5 23 36
	Rohde & Schwarz SIT GmbH Agastraße 3 D-12489 Berlin	+49 (30) 658 84-0 +49 (30) 658 84-183 -
	ADDRESSES GERMANY	
	Rohde & Schwarz Vertriebs-GmbH Mühlendorfstraße 15 · D-81671 München Postfach 80 14 69 · D-81614 München	+49 (89) 4129-133 74 +49 (89) 4129-133 77 -

Branch offices of Rohde & Schwarz Vertriebs-GmbH

Zweigniederlassung Nord, Geschäftsstelle Berlin Ernst-Reuter-Platz 10 · D-10587 Berlin Postfach 100620 · D-10566 Berlin	+49 (30) 34 79 48-0 +49 (30) 34 79 48 48 -
Zweigniederlassung Büro Bonn Josef-Wirmer-Straße 1-3 · D-53123 Bonn Postfach 140264 · D-53057 Bonn	+49 (228) 918 90-0 +49 (228) 25 50 87 -
Zweigniederlassung Nord, Geschäftsstelle Hamburg Steilshooper Alle 47 · D-22309 Hamburg Postfach 60 22 40 · D-22232 Hamburg	+49 (40) 38 61 83-00 +49 (40) 38 61 83-20 -
Zweigniederlassung Mitte, Geschäftsstelle Köln Niederlasser Straße 33 · D-51147 Köln Postfach 900 149 · D-51111 Köln	+49 (2203) 807-0 +49 (2203) 807-650 -
Zweigniederlassung Süd, Geschäftsstelle München Mühldorfstraße 15 · D-81671 München Postfach 80 14 69 · D-81614 München	+49 (89) 41 86 95-0 +49 (89) 40 47 64 -
Zweigniederlassung Süd, Geschäftsstelle Nürnberg Donaustraße 36 D-90451 Nürnberg	+49 (911) 642 03-0 +49 (911) 642 03-33 -
Zweigniederlassung Mitte, Geschäftsstelle Neu-Isenburg Siemensstraße 20 D-63263 Neu-Isenburg	+49 (6102) 20 07-0 +49 (6102) 20 07 12 -

ADDRESSES WORLDWIDE

Albania	see Austria	
Algeria	ROHDE & SCHWARZ Bureau d'Alger 5B Place de Laperrine 16035 Hydra-Alger	+213 (20) 28 10-21 or 22 +213 (21) 69 46 08 -
Argentina	PRECISION ELECTRONICA S.R.L. Av. Pde Julio A. Roca 710 - 6° Piso (C1067ABP) Buenos Aires	+541 (14) 331 10 67 +541 (14) 334 51 11 alberto_lombardi@prec-elec.com.ar
Australia	ROHDE & SCHWARZ (AUSTRALIA) Pty. Ltd. Sales Support Unit 6 2-8 South Street Rydalmere, N.S.W. 2116	+61 (2) 88 45 41 00 +61 (2) 96 38 39 88 lyndell.james@rsaus.rohde-schwarz.com
Austria	ROHDE & SCHWARZ-ÖSTERREICH Ges.m.b.H. Am Europlatz 3 1120 Wien	+43 (1) 602 61 41-0 +43 (1) 602 61 41-14 rs-austria@rsoe.rohde-schwarz.com
Azerbaijan	ROHDE & SCHWARZ Azerbaijan Liaison Office Baku ISR Plaza, 5 th floor 340 Nizami Str. 370000 Baku	+994 (12) 493 31 38 +994 (12) 493 03 14 RS-Azerbaijan@RUS.Rohde-Schwarz.com
Bangladesh	BIL Consortium Ltd. House 33, Block - 'F' Road No. 4, Banani Dhaka-1213	+880 (2) 881 06 53 +880 (2) 882 82 91 -
Belgium	ROHDE & SCHWARZ BELGIUM N.V. Excelsiorlaan 31 Bus 1 1930 Zaventem	+32 (2) 721 50 02 +32 (2) 725 09 36 info@rsb.rohde-schwarz.com

List of Rohde & Schwarz Offices

R&S FS315

Bosnia-Herzegovina	See Slovenia	
Brasil	ROHDE & SCHWARZ DO BRASIL LTDA. Av. Alfredo Egidio de Souza Aranha, 177, 1º andar - Santo Amaro 04726-170 Sao Paulo – SP	+55 (11) 56 44 86 11 (general) +55 (11) 56 44 86 25 (sales) +55 (11) 56 44 86 36 sales-brazil@rsdb.rohde-schwarz.com
Brunei	GKL Equipment PTE. Ltd. #11-01 BP Tower 396 Alexandra Road Singapore 119954	+65 (6) 276 06 26 +65 (6) 276 06 29 gkleqpt@singnet.com.sg
Bulgaria	ROHDE & SCHWARZ ÖSTERREICH Representation Office Bulgaria 39, Fridtjof Nansen Blvd. 1000 Sofia	+359 (2) 963 43 34 +359 (2) 963 21 97 rs-bulgaria@rsbg.rohde-schwarz
Canada	ROHDE & SCHWARZ CANADA Inc. 555 March Rd. Kanata, Ontario K2K 2M5	+1 (613) 592 80 00 Toll free: +1 (877) 438 28 80 +1 (613) 592 80 09 cgirwarnauth@rscanada.ca
Chile	DYMEQ Ltda. Av. Principe de Gales 6225, La Reina, Santiago Chile	+56 (2) 339 20 00 +56 (2) 339 20 10 dymeq@dymeq.com
China	ROHDE & SCHWARZ China Ltd. Representative Office Shanghai Central Plaza, Room 807-809 227 Huangpi North Road RM 807/809 Shanghai 200003	+86 (21) 63 75 00 18 +86 (21) 63 75 91 70 -
China	ROHDE & SCHWARZ China Ltd. Representative Office Beijing Room 6F, Parkview Center 2 Jiangtai Road Chao Yang District Beijing 100016	+86 (10) 64 31 28 28 +86 (10) 64 37 98 88 info.rschina@rsbp.rohde-schwarz.com
China	ROHDE & SCHWARZ China Ltd. Representative Office Guangzhou Room 2903, Metro Plaza 183 Tianhe North Road Guangzhou 510075	+86 (20) 87 55 47 58 +86 (20) 87 55 47 59 -
China	ROHDE & SCHWARZ China Ltd. Representative Office Chengdu Unit G, 28/F, First City Plaza 308 Shuncheng Avenue Chengdu 610017	+86 (28) 86 52 76 06 +86 (28) 86 52 76 10 rsbpc@mail.sc.cninfo.net
China	ROHDE & SCHWARZ China Ltd. Representative Office Xi'an Room 603, Jin Xin International No. 99, Heping Road Xi'an 710048	+86 (29) 87 41 53 77 +86 (29) 87 20 65 00 sherry.yu@rsbp.rohde-schwarz.com
China	Rohde & Schwarz China Ltd. Representative Office Shenzhen Central Business Building, No. 88, Room 1901, Fuhua Yilu, Futian District Shenzhen 518026	+86 (755) 82 03 1198 +86 (755) 82 03 30 70 jessica.lia@rsbp.rohde-schwarz.com
Croatia	see Slovenia	
Cyprus	HINIS TELECAST LTD. Agiou Thoma 18 Kiti Larnaca 7550	+357 (24) 42 51 78 +357 (24) 42 46 21 hinis@logos.cy.net

Czech Republic	ROHDE & SCHWARZ - Praha s.r.o. Hadovka Office Park Evropská 2590 / 33c 16000 Praha 6	+420 (2) 24 31 12 32 +420 (2) 24 31 70 43 office@rscz.rohde-schwarz.com
Denmark	ROHDE & SCHWARZ DANMARK A/S Ejby Industrivej 40 2600 Glostrup	+45 (43) 43 66 99 +45 (43) 43 77 44 -
Egypt	U.A.S. Universal Advanced Systems 31 Manshiet El-Bakry Street Heliopolis 11341 Cairo	+20 (2) 455 67 44 +20 (2) 256 17 40 an_uas@link.net
El Salvador	see Mexico (EPSA)	
Estonia	ROHDE & SCHWARZ DANMARK A/S Estonian Branch Office Narva mt. 13 10151 Tallinn	+372 (6) 14 31 20 +372 (6) 14 31 21 margo.fingling@rsdk.rohde-schwarz.com
Finland	ROHDE & SCHWARZ Finland Oy Tuivaltie 5 01610 Vantaa	+358 (207) 600 04 00 +358 (207) 60 04 17 info.rsfin@rohde-schwarz.com
France	ROHDE & SCHWARZ FRANCE Immeuble "Le Newton" 9-11, rue Jeanne Braconnier 92366 Meudon La Forêt Cédex	+33 (1) 41 36 10 00 +33 (1) 41 36 11 11 -
France	Office Rennes 37 Rue du Bignon Bât. A F-35510 Cesson Sevigne	+33 (2) 99 51 97 00 +33 (2) 99 51 98 77 -
Ghana	KOP Engineering Ltd. P.O. Box 11012 3rd Floor Akai House, Osu Accra North	+233 (21) 77 89 13 +233 (21) 701 06 20 -
Greece	MERCURY S.A. 6, Loukianou Str. 10675 Athens	+302 (10) 722 92 13 +302 (10) 721 51 98 mercury@hol.gr
Guatemala	see Mexico	
Honduras	see Mexico	
Hongkong	Electronic Scientific Engineering Ltd. 9/F North Somerset House Taikoo Place 979 King's Road Quarry Bay, Hong Kong	+852 (25) 07 03 33 +852 (25) 07 09 25 stephenchau@ese.com.hk
Hungary	ROHDE & SCHWARZ Budapesti Iroda Váci út 169 1138 Budapest	+36 (1) 412 44 60 +36 (1) 412 44 61 rs-hungary@rshu.rohdeschwarz.com
Iceland	see Denmark	
India	ROHDE & SCHWARZ India Pvt. Ltd. Bangalore Office No. 24, Service Road, Domlur 2nd Stage Extension Bangalore – 560 071	+91 (80) 25 35 23 62 +91 (80) 25 35 03 61 rsindiab@rsnl.net

List of Rohde & Schwarz Offices**R&S FS315**

India	ROHDE & SCHWARZ India Pvt. Ltd. Hyderabad Office 302 & 303, Millenium Centre 6-3-1099/1100, Somajiguda Hyderabad - 500 016	+91 (40) 23 32 24 16 +91 (40) 23 32 27 32 rsindiah@nd2.dot.net.in
India	ROHDE & SCHWARZ India Pvt. Ltd. 244, Okhla Industrial Estate, Phase-III New Delhi 110020	+91 (11) 26 32 63 81 +91 (11) 26 32 63 73 sales@rsindia.rohde-schwarz services@rsindia.rohde-schwarz.com
India	ROHDE & SCHWARZ India Pvt. Ltd. Mumbai Office B-603, Remi Bizcourt, Shah Industrial Estate, Off Veera Desai Road, Andheri West Mumbai - 400 058	+91 (22) 56 99 38 77 +91 (22) 26 73 20 81 rsindiam@rsnl.net
Indonesia	PT ROHDE & SCHWARZ Indonesia Graha Paramita 5th Floor Jln. Denpasar Raya Blok D-2 Jakarta 12940	+62 (21) 252 36 08 +62 (21) 252 36 07 sales@rsbj.rohde-schwarz.com services@rsbj.rohde-schwarz.com
Iran	ROHDE & SCHWARZ IRAN Liason Office Teheran Groundfloor No. 1, 14th Street Khaled Eslamboli (Vozara) Ave. 15117 Tehran	+98 (21) 872 42 96 +98 (21) 871 90 12 rs-tehran@neda.net
Ireland	see United Kingdom	
Israel	Test & Measurement EASTRONICS LTD. 11 Rozanis St. P.O.Box 39300 Tel Aviv 61392	+972 (3) 645 87 77 +972 (3) 648 66 66 david_hasky@easx.co.il
Israel	Communications Equipment J.M. Moss Engineering Ltd. 9 Oded Street P.O.Box 967 52109 Ramat Gan	+972 (3) 631 20 57 +972 (3) 631 40 58 jmmoss@zahav.net.il
Italy	ROHDE & SCHWARZ ITALIA S.p.a. Centro Direzionale Lombardo Via Roma 108 20060 Cassina de Pecchi (MI)	+39 (02) 957 04-1 +39 (02) 957 04-608 ornella.crippa@rsi.rohde-schwarz.com
Italy	ROHDE & SCHWARZ ITALIA S.p.a. Via Tiburtina 1182 00156 Roma	+39 (06) 415 98-1 +39 (06) 415 98-308
Japan	Rohde & Schwarz 711 bldg., Room 501 (5th floor) 7-11-18 Nishi-Shinjuku Shinjuku-ku Tokyo 160-0023	+81 (3) 59 25 12 88 +81 (3) 59 25 12 90
Jordan	Jordan Crown Engineering & Trading Co. Jabal Amman, Second Circle Youssef Ezzideen Street P.O.Box 830414 Amman, 11183	+962 (6) 462 17 29 +962 (6) 465 96 72 jocrown@go.com.jo
Kazakhstan	ROHDE & SCHWARZ Kazakhstan Representative Office Almaty Pl. Respubliki 15 480013 Almaty	+7 (32) 72 67 23 54 +7 (32) 72 67 23 46 RS-Kazakhstan@RUS-Rohde- Schwarz.com
Kenya	Excel Enterprises Ltd Dunga Road P.O.Box 42 788 Nairobi	+254 (2) 55 80 88 +254 (2) 54 46 79 -

Korea	ROHDE & SCHWARZ Korea Ltd. 83-29 Nonhyun-Dong, Kangnam-Ku Seoul 135-010	+82 (2) 3485 1900 +82 (2) 5474 300 sales@rskor.rohde-schwarz.com service@rskor.rohde-schwarz.com
Latvia	ROHDE & SCHWARZ DANMARK A/S Latvian Branch Office Merkela iela 21-301 1050 Riga	+371 (7) 50 23 55 +371 (7) 50 23 60 rsdk@rsdk.rohde-schwarz.com
Lebanon	ROHDE & SCHWARZ Liaison Office Liaison Office Riyadh P.O.Box 361 Riyadh 11411	+966 (1) 293 20 35 +966 (1) 456 16 57 chris.porzky@rsd.rohde-schwarz.com
Lebanon	Netcom Horsh Tabet P.O.Box 55199 Beirut	+961-1-48 69 99 +961-1-49 05 11 netcom@inco.com.lb
Liechtenstein	see Switzerland	
Lithuania	ROHDE & SCHWARZ DANMARK A/S Lithuanian Branch Office Laisves pr.3 04132 Vilnius	+370 (5) 239 50 10 +370 (5) 239 50 11 -
Luxembourg	see Belgium	
Macedonia	NETRA Leukata 2 Skopje	+389 (2) 309 28 20 +389 (2) 306 79 20
Malaysia	ROHDE & SCHWARZ Malaysia No. 9, Jalan SS 4D/2 Selangor Darul Ehsan 47301 Petaling Jaya	+60 (3) 78 03 55 68 +60 (3) 78 03 34 39 maryanne@danik.com.my
Malta	Tektraco International Technology Ltd 121 B*Kara Road San Gwann SGN 08	+356 (21) 37 43 00 oder 37 80 88 +356 (21) 37 66 67 sales@itec.com.mt
Mexico	Rohde & Schwarz de Mexico German Centre Oficina 4-2-2 Av. Santa Fé 170 Col. Lomas de Santa Fé 01210 Mexico D.F.	+52 (55) 85 03 99 13 +52 (55) 85 03 99 16 latinoamerica@rsd.rohde-schwarz.com
Mexico	Rohde & Schwarz de Mexico Av. Prol. Americas No. 1600, 2° Piso Country Club Guadalajara, Jal. Mexico CP, 44610	+52 (33) 36 78 91 70 +52 (33) 36 78 92 00
Moldavia	see Romania	
Nepal	ICTC Pvt. Ltd. Hattisar, Post Box No. 660 Kathmandu	+977 (1) 443 48 95 +977 (1) 443 49 37 ictc@mos.com.np
Netherlands	ROHDE & SCHWARZ NEDERLAND B.V. Perkinsbaan 1 3439 ND Nieuwegein	+31 (30) 600 17 00 +31 (30) 600 17 99 info@rsn.rohde-schwarz.com
New Zealand	Nichecom 1 Lincoln Ave. Tawa, Wellington	+64 (4) 232 32 33 +64 (4) 232 32 30 rob@nichecom.co.nz
Nicaragua	see Mexico	

Nigeria	Ferrostaal Abuja Plot 3323, Barada Close P.O.Box 8513, Wuse, Victoria Island Off Amazon Street Maitama, Abuja	+234 (9) 413 52 51 +234 (9) 413 52 50 fsabuja@rosecom.net
Norway	ROHDE & SCHWARZ NORGE AS Enebakkveien 302 B 1188 Oslo	+47 (23) 38 66 00 +47 (23) 38 66 01 -
Oman	T&M and Broadcasting Equipment Mustafa Sultan Science & Industry Co.LLC. Way No. 3503 Building No. 241 Postal Code 112 Al Khuwair, Muscat	+968 63 60 00 +968 60 70 66 m-aziz@mustafasultan.com
Pakistan	Head office Islamabad: Sardar Mansion 21 West Jinnah Avenue Fazal-ul-Haq Road, Blue Area Islamabad	+92 51 111 050 050 +92 51 2879 298
Pakistan	Branch office Karachi: 8-N, Block-6, P.E.C.H.S, Karachi - 75400	+92 21 4398554 47 48 +92 21 4398549
Panama	see Mexico	
Papua-New Guinea	see Australia	
Philippines	Rohde & Schwarz (Philippines) Ltd. Unit 2301, PBCom Tower Ayala Ave. cor. Herrera Sts. Makati City	+63 (2) 753 14 44 +63 (2) 753 14 56
Poland	ROHDE & SCHWARZ Österreich SP.z o.o. Przedstawicielstwo w Polsce ul. Stawki 2, Pietro 28 00-193 Warszawa	+48 (22) 860 64 94 +48 (22) 860 64 99 rs-poland@rspl.rohde-schwarz.com
Portugal	Rohde & Schwarz Portugal, Lda. Alameda Antonio Sergio, 7-R/C - Sala A 2795-023 Linda-a-Velha	+351 (21) 415 57 00 +351 (21) 415 57 10 info@rspt.rohde-schwarz.com
Romania	ROHDE & SCHWARZ Representation Office Bucharest 89 Eroii Sanitari Blvd., 050472 Bucuresti, Sector 5	+40 (1) 411 20 13 +40 (21) 410 68 46 rs-romania@rsro.rohde-schwarz.com
Russian Federation	ROHDE & SCHWARZ Representative Office Moscow ul. 1-st Brestskaya 29, 9 th floor 125047 Moscow	+7 (095) 981 35 60 +7 (095) 981 35 65 rs-russia@rsru.rohde-schwarz.com
Saudi Arabia	Rohde & Schwarz Liaison Office Riyadh c/o Haji Abdullah Alireza Co. Ltd. P.O.Box 361 Riyadh 11411	+966 (1) 293 20 35 +966 (1) 466 16 57 chris.porzky@rsd.rohde-schwarz.com
Serbia-Montenegro	ROHDE & SCHWARZ Representative Office Belgrade Tose Jovanovica 7 11030 Beograd	+381 (11) 305 50 25 +381 (11) 305 50 24 -

Singapore	Rohde & Schwarz Regional Headquarters Singapore Pte. Ltd. 1 Kaki Bukit View #04-01/07 Techview Singapore 415 941	+65 (6) 846 1872 +65 (6) 846 1252 rsca@rssg.rohde-schwarz.com
Slovak Republic	Specialne systémy a software, a.s. Svrčia ul. 841 04 Bratislava	+421 (2) 65 42 24 88 +421 (2) 65 42 07 68 stefan.lozek@special.sk
Slovenia	ROHDE & SCHWARZ Representation Ljubljana Tbilisijska 89 1000 Ljubljana	+386 (1) 423 46 51 +386 (1) 423 46 11 rs-slovenia@rssi.rohde-schwarz.com
South Africa	Protea Data Systems (Pty.) Ltd. Communications and Measurement Division Private Bag X19 Bramley 2018	+27 (11) 719 57 00 +27 (11) 786 58 91 unicm@protea.co.za
South Africa	Protea Data Systems (Pty.) Ltd. Cape Town Branch Unit G9, Centurion Business Park Bosmandam Road Milnerton Cape Town, 7441	+27 (21) 555 36 32 +27 (21) 555 42 67 unicm@protea.co.za
Spain	ROHDE & SCHWARZ ESPANA S.A. Salcedo, 11 28034 Madrid	+34 (91) 334 10 70 +34 (91) 329 05 06 rses@rses-rohde-schwarz.com
Sri Lanka	Dynatel Communications (PTE) Ltd. 451/A Kandy Road Kelaniya	+94 (1) 90 80 01 +94 (1) 91 04 69 dyna-svc@sltnet.lk
Sudan	SolarMan Co. Ltd. P.O.Box 11 545 North of Fraouq Cementry 6/7/9 Bldg. 16 Karthoum	+249 (11) 47 31 08 +249 (11) 47 31 38 solarman29@hotmail.com
Sweden	ROHDE & SCHWARZ SVERIGE AB Flygfältsgatan 15 128 30 Skarpnäck	+46 (8) 605 19 00 +46 (8) 605 19 80 info@rss.se
Switzerland	Roschi Rohde & Schwarz AG Mühlestr. 7 3063 Ittigen	+41 (31) 922 15 22 +41 (31) 921 81 01 sales@roschi.rohde-schwarz.com
Syria	Electro Scientific Office Baghdad Street Dawara Clinical Lab. Bldg P.O.Box 8162 Damascus	+963 (11) 231 59 74 +963 (11) 231 88 75 memo@hamshointl.com
Taiwan	Rohde & Schwarz Taiwan (Pvt.) Ltd. Floor 14, No. 13, Sec. 2, Pei-Tou Road Taipei 112	+886 (2) 28 93 10 88 +886 (2) 28 91 72 60 celine.tu@rstw.rohde-schwarz.com
Tanzania	SSTL Group P.O. Box 7512 Dunga Street Plot 343/345 Dar es Salaam	+255 (22) 276 00 37 +255 (22) 276 02 93 sstl@twiga.com
Thailand	Test & Measurement: Schmidt Electronics (Thailand) Ltd. 202 Le Concorde Tower, 23 rd floor, Ratcha- daphisek Road, Huaykwang, Bangkok 10320	+66 (2) 69 41 47 05 +66 (2) 69 41 47 6 kamthoninthuyot@schmidttailand.com
Trinidad & Tobago	see Mexico	

List of Rohde & Schwarz Offices**R&S FS315**

Tunisia	TELETEK 71, Rue Alain Savary Residence Alain Savary (C64) 1003 Tunis	+216 (71) 77 33 88 +216 (71) 77 05 53
Turkey	ROHDE & SCHWARZ International GmbH Liaison Office Istanbul Bagdad Cad. 191/3, Arda Apt. B-Blok 81030 Selamicesme-Istanbul	+90 (216) 385 19 17 +90 (216) 385 19 18 rsturk@superonline.com
Ukraine	ROHDE & SCHWARZ Representative Office Kiev 4, Patris Loumoumba ul 252042 Kiev	+38 (044) 268 83 64 +38 (044) 268 60 55 rsbkiev@public.ua.net
United Arab Emirates	ROHDE & SCHWARZ International GmbH Liaison Office Middle East P.O. Box 31156 Abu Dhabi	+971 (2) 633 56 70 +971 (4) 633 56 71 michael.rogler@rsd.rohde-schwarz.com
United Arab Emirates	Professional Mobile Radio ROHDE & SCHWARZ Bick Mobile Communication P.O.Box 17466 Dubai	+971 (4) 883 71 35 +971 (4) 883 71 36
United Arab Emirates	Service Center for the Middle East ROHDE & SCHWARZ Emirates L.L.C. ESNAAD Premises at Mussafah P.O.Box 31156 Abu Dhabi	+971 (2) 55 49 411 +971 (2) 55 49 433 rsuaeam@emirates.net.ae
United Kingdom	ROHDE & SCHWARZ UK Ltd. Ancells Business Park Fleet Hampshire GU 51 2UZ	+44 (1252) 81 88 88 +44 (1252) 81 14 47 sales@rsuk.rohde-schwarz.com
Uruguay	AEROMARINE S.A. Cerro Largo 1497 11200 Montevideo	+598 (2) 400 39 62 +598 (2) 401 85 97 mjn@aeromarine.com.uy
USA	Service and Calibration Center: Rohde & Schwarz, Inc. 8661-A Robert Fulton Drive Columbia, MD 21046-2265	+1 (410) 910 50 02 +1 (410) 910 79 31 rsatv@rsa.rohde-schwarz.com rsacomms@rsa.rohde-schwarz.com
USA	R&D and Application Support Rohde & Schwarz Inc. 8905 SW Nimbus Ave., Suite 240 Beaverton, OR 97008	+1 (503) 40 34 700 +1 (503) 40 34 701 info@rsa.rohde-schwarz.com
USA	Central Regional Office: Rohde & Schwarz Inc. 8080 Tristar Drive Suite 120 Irving, Texas 75063	+1 (469) 713 53 00 +1 (469) 713 53 01 info@rsa.rohde-schwarz.com
Vietnam	ROHDE & SCHWARZ Representative Office Vietnam, Unit 807, 8/F, Schmidt Tower 239 Xuan Thuy Road Cau Giay District Hanoi	+84 (4) 834 20 46 svnhn@schmidtgroup.com

1 Introduction

This chapter	Chapter 1 describes the uses of the R&S FS315 and also provides information on the storage and transportation procedures that should be adopted for the instrument. Warranty conditions are also explained.
Further information	Chapter 2 contains an overview of the R&S FS315's control elements, indicators, etc. Chapter 3 describes how to put the R&S FS315 into operation.

1.1 Applications for the R&S FS315

Uses	<p>RF signals are used by telecommunication systems to transmit information. The transmitted power must remain within strictly specified frequency bands, otherwise interference with other services on adjacent channels would occur.</p> <p>To ensure that the stringent requirements laid down for RF communication systems are met, it is essential to have measuring equipment that can precisely measure and analyze the modulated and unmodulated signals involved.</p>
Performance features	<p>The Spectrum Analyzer R&S FS315 has all the performance features required to perform precise level and frequency measurements.</p> <p>The key features are:</p> <ul style="list-style-type: none">▪ High-Quality RF characteristics▪ Resolution bandwidth from 200 Hz to 1 MHz▪ Frequency counter with 1 Hz resolution▪ Maximum input level +33 dBm▪ Ergonomic user interface
Operation from keypad	<p>All functions and measurement parameters can be set via menus using a keypad and a rotary knob.</p> <p>The current trace, along with the key parameters and status indicators needed to evaluate the results, can be read at a glance from the TFT colour screen.</p>
Remote control via PC	<p>The R&S FS315 is equipped as standard with a USB interface so that it can communicate with a PC. All functions and parameters can be set.</p>

1.2 Supplied Accessories

Content	1 power cord Europe
	1 country specific power cord (if different from Europe)
	1 manual German/English
	1 USB cable
	1 CD (Content: operating manual German/English, data sheet German/English PC software R&S FS315-K1, Acrobat Reader™)

1.3 Warranty

Warranty conditions	The General Terms and Conditions of Rohde & Schwarz shall apply.
Returning a defective R&S FS315	Please observe the packaging instructions (➤ 0-18). You will find the addresses of your nearest R&S representative and of the support center at the front of the manual.
Indicating claims under the warranty	We would also ask you to state clearly if you are making a claim for repairs under warranty, preferably by including your delivery note. Repair requests that do not explicitly refer to the warranty will, in the first instance, incur charges. If your warranty has expired, we will, of course, repair your R&S FS315 in accordance with our general installation and service conditions.

2 Control Elements

2.1 Front View

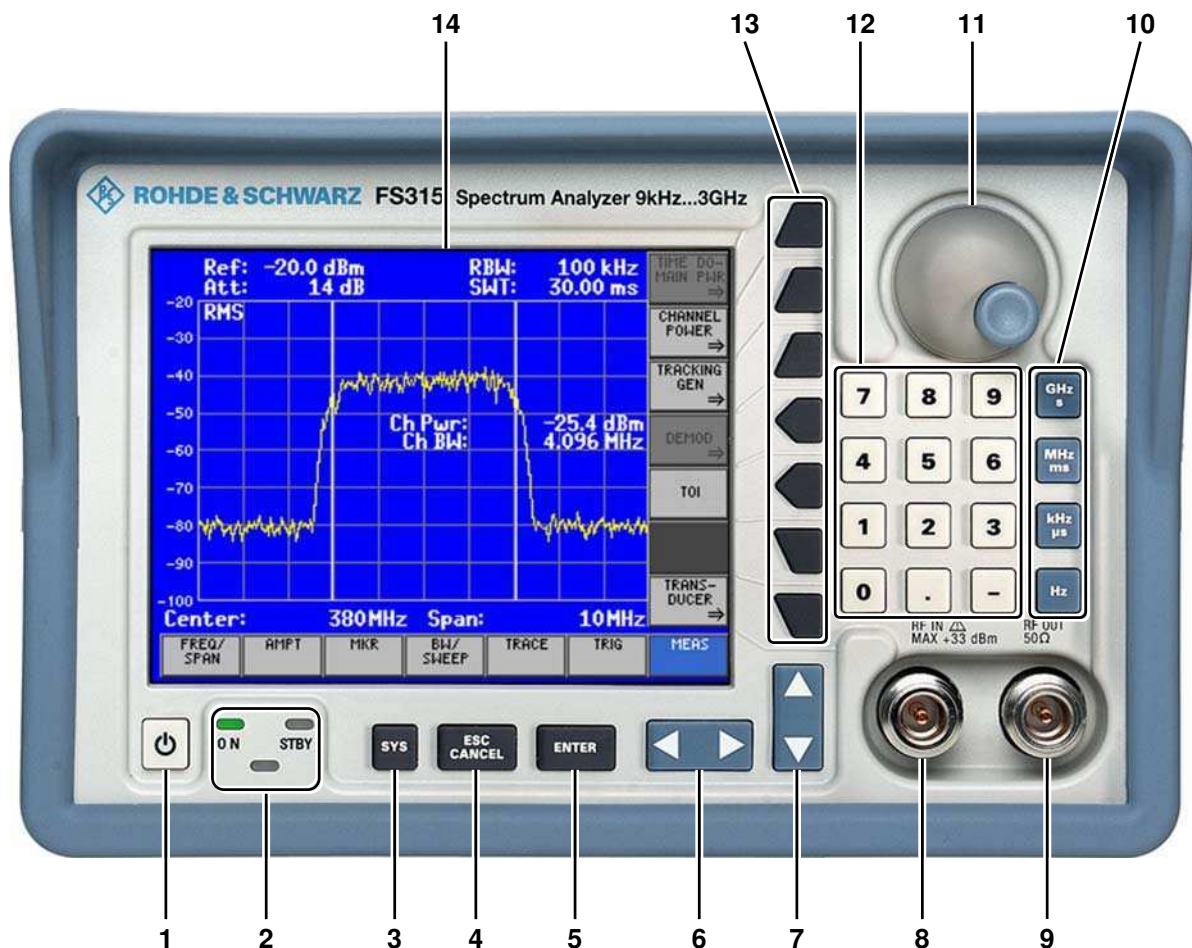

- | | | | |
|---|----------------------|----|-----------------------------|
| 1 | ON/STANDBY switch | 8 | RF IN, RF input connector |
| 2 | ON/STANDBY indicator | 9 | RF OUT, RF output connector |
| 3 | BACK/SYS key | 10 | Unit keys |
| 4 | ESC/CANCEL key | 11 | Rotary knob |
| 5 | ENTER key | 12 | Numerical keys |
| 6 | Cursor keys ◀ / ▶ | 13 | Function keys |
| 7 | Cursor keys ▼ / ▲ | 14 | Screen |

2.2 Rear View

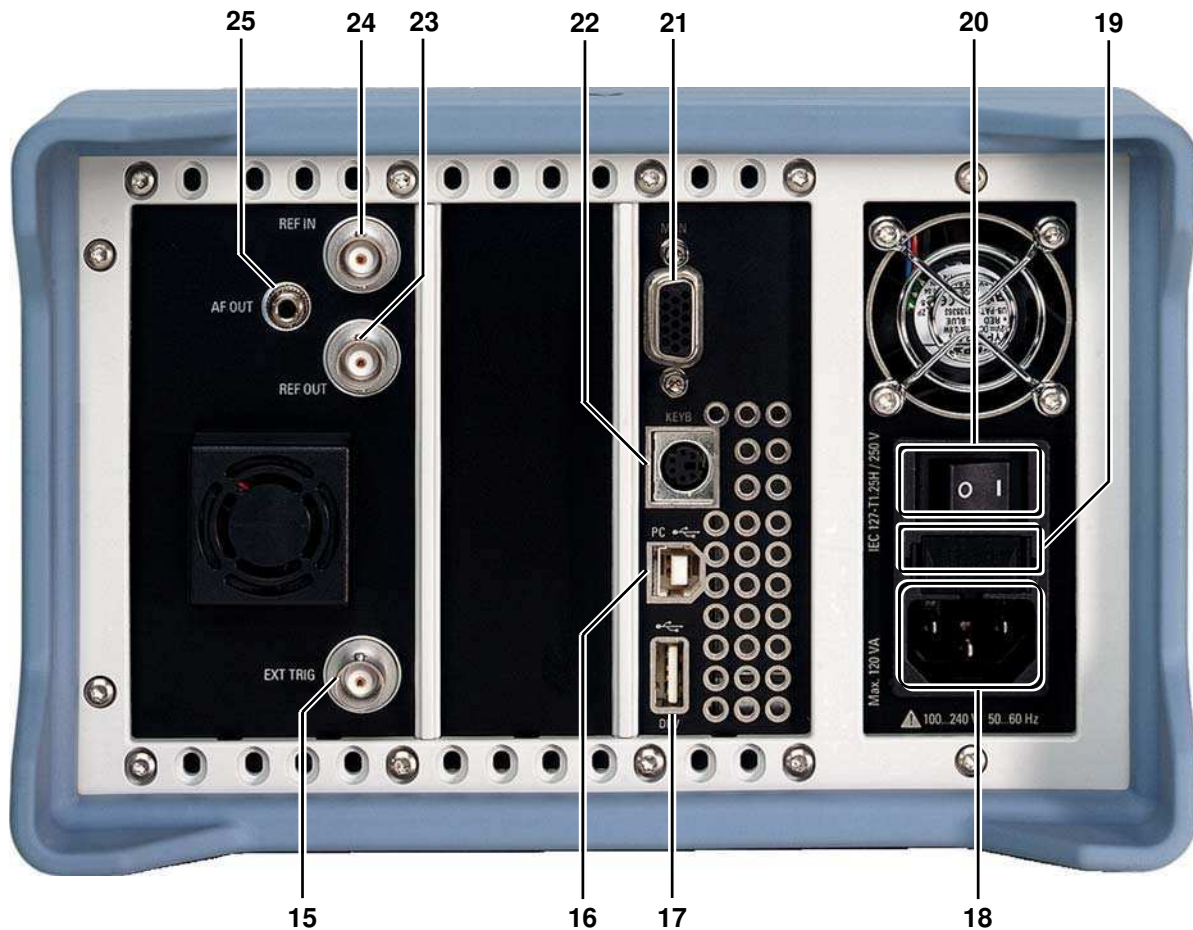

- | | | | |
|----|--|----|---|
| 15 | Input connector for external trigger | 20 | AC line switch |
| 16 | Connector for external USB host | 21 | Connector for external monitor |
| 17 | Output connector for USB device
(e. g. printer) | 22 | Connector for external keyboard |
| 18 | Power supply connector | 23 | Output of internal/external reference
(10 MHz) |
| 19 | AC line fuses | 24 | Input for external reference (10 MHz) |
| | | 25 | Headphone output |

3 Putting the R&S FS315 into Operation

This chapter

Chapter 3 describes how to put the R&S FS315 into operation.

Further information

Chapter 2 contains an overview of the R&S FS315's control elements, indicators, etc.

Chapter 4 "Getting started", takes you step-by-step through a number of simple measurements.

Chapter 8 is an in-depth description of the instrument's interfaces.



Caution

Before putting the R&S FS315 into operation, make the following checks:

- Ensure that the ventilation holes are free of obstructions.
- Ensure that there are no unsuitable signal voltages connected to the input.
- The R&S FS315's outputs may not be overloaded and correct polarity must be ensured.

The instrument may be damaged if the above checks are not performed.

3.1 Unpacking the R&S FS315

Recommended procedure

When you unpack the R&S FS315, proceed as follows:

1. Remove the R&S FS315 from its packaging and check that the delivery is complete using the accessory list (↗ 1-34).
2. Carefully check the R&S FS315 for any damage.
3. If there is damage, immediately contact the carrier who delivered the instrument. Under these circumstances, it is essential to keep the box in which the R&S FS315 was transported and the packaging material (↗ 0-18).

3.2 Setting up the Instrument



Caution

There is a risk of injury from sharp edges and becoming wedged between the setting lever and the handle.

Setup instructions

The R&S FS315 must be assembled on a firm, level surface only. The instrument has a carrying handle which is also used for various setup options. This handle can be moved into any position, depending on the particular field of application.

Setting the handle

1. Place the thumb and two fingers around the side-mounted setting lever and loosen it with a turning action.



2. Slide the handle lengthwise while twisting it radially in steps of about 12°.

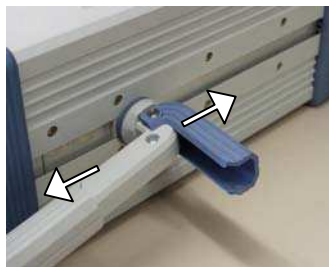

3. Close the setting lever by pressing on the outer surface.

Caution: There is a risk of injury from sharp edges and becoming wedged between the setting lever and the handle.



4. Remove the protective film from the screen glass if necessary.

Caution: Use no pointed or sharp objects.



3.3 Connecting the R&S FS315 to the AC Line



Caution

The R&S FS315 meets the requirements for Safety Class I to DIN EN 61010-1/IEC 61010-1, e.g. all metal parts that can be touched or accessed without removing the enclosure are connected to the protective ground of the power supply network.

The connection to the AC line is made via a power cord and a connector with a protective ground contact.

Automatic AC line voltage detection

When the R&S FS315 is connected to the AC line, it automatically sets itself to the correct voltage (range: AC voltage 100 V to 240 V, AC frequency 50 Hz to 60 Hz). There is no need to set the voltage manually or change the fuse.

Connecting the AC line

1. Use the supplied power cord to connect the R&S FS315 to the AC line.
The power supply connector [18] is at the rear of the instrument.
2. Connect the power cord to the AC line.

3.4 Switching On the R&S FS315



Hazard

The AC line is still connected to the R&S FS315 when the instrument is in the standby mode.

AC line switch on the rear panel

The R&S FS315 is connected to the AC line via power supply connector [18]. AC line switch [20] which isolates the R&S FS315 from the AC line is located next to the power supply connector.

ON/STANDBY switch on the front panel

ON operating state

After switching on the R&S FS315 by means of the AC line switch [20] at the rear panel, it is in standby mode and the yellow LED [2] comes on. If you press the ON/STANDBY switch [1], the instrument is switched on and the green LED [2] comes on.

STANDBY operating state

To switch the R&S FS315 from the operating mode to standby mode, press the ON/STANDBY switch [1] for approx. 2 seconds. After switching off the ON/STANDBY switch [1] the yellow LED [2] comes on.

Switching on the R&S FS315

1. Press the AC line switch [20] on the rear panel in the I position.
2. Press the ON/STANDBY switch [1] on the front panel.
The green ON LED [2] should come on.

3.5 Function Test

**Caution**

When performing service procedures, follow the requirements of VDE 0701. Only properly qualified technicians are allowed to repair the R&S FS315. The instrument does not contain any parts the operator can repair.

Function test

After the R&S FS315 has been switched on (↗ 3-39), the green LED ON [2] on the instrument's front panel comes on. During booting, the "R&S Smart Instruments" symbol appears on a blue screen background [14]. Booting the R&S FS315 is completed when the measurement mask (↗ 5-50) and the trace appear. If the measurement trace does not appear on the screen, the sweep time (↗ 6-126) may have been too long.

In error case

If the measurement mask (↗ 5-50) does not appear and the red or the red or green LED flash alternately, switch the R&S FS315 off and on. In case the error continues, return the instrument to our service center for checking. If the instrument shows an error message after booting, then follow the instructions in the chapter "Error messages" (↗ 9-272).

**Note**

If the measurement trace does not appear on the screen shortly after booting, the sweep time may have been too long. In this case, reset the R&S FS315 by means of PRESET (↗ 6-169). If the trace still fails to appear, an error occurred and our service center must check the instrument.

3.6 EMC

EMC requirements

The R&S FS315 meets the EMC Directive 89/336/EEC (applied standards EN 55011 Class B and EN 61326).

To prevent EMI, the R&S FS315 may only be operated with its enclosure closed. Only appropriately shielded signal and control cables may be used. External units, such as keyboard, printer or monitor, that are to be connected to the R&S FS315 must comply with EMC directives.

3.7 Connecting an External Keyboard



Caution

Only connect the keyboard when the R&S FS315 is off or in the STANDBY mode, otherwise malfunctions may occur at a later date.

Use

You can connect an external PC keyboard via the 6-pin PS/2 KEYBOARD connector [22] on the R&S FS315's rear panel. The keyboard makes it easier to enter file names. The keyboard allows data entry as well as operation of the R&S FS315.

The keyboard is detected automatically when it is connected.

Key assignment for operating the R&S FS315

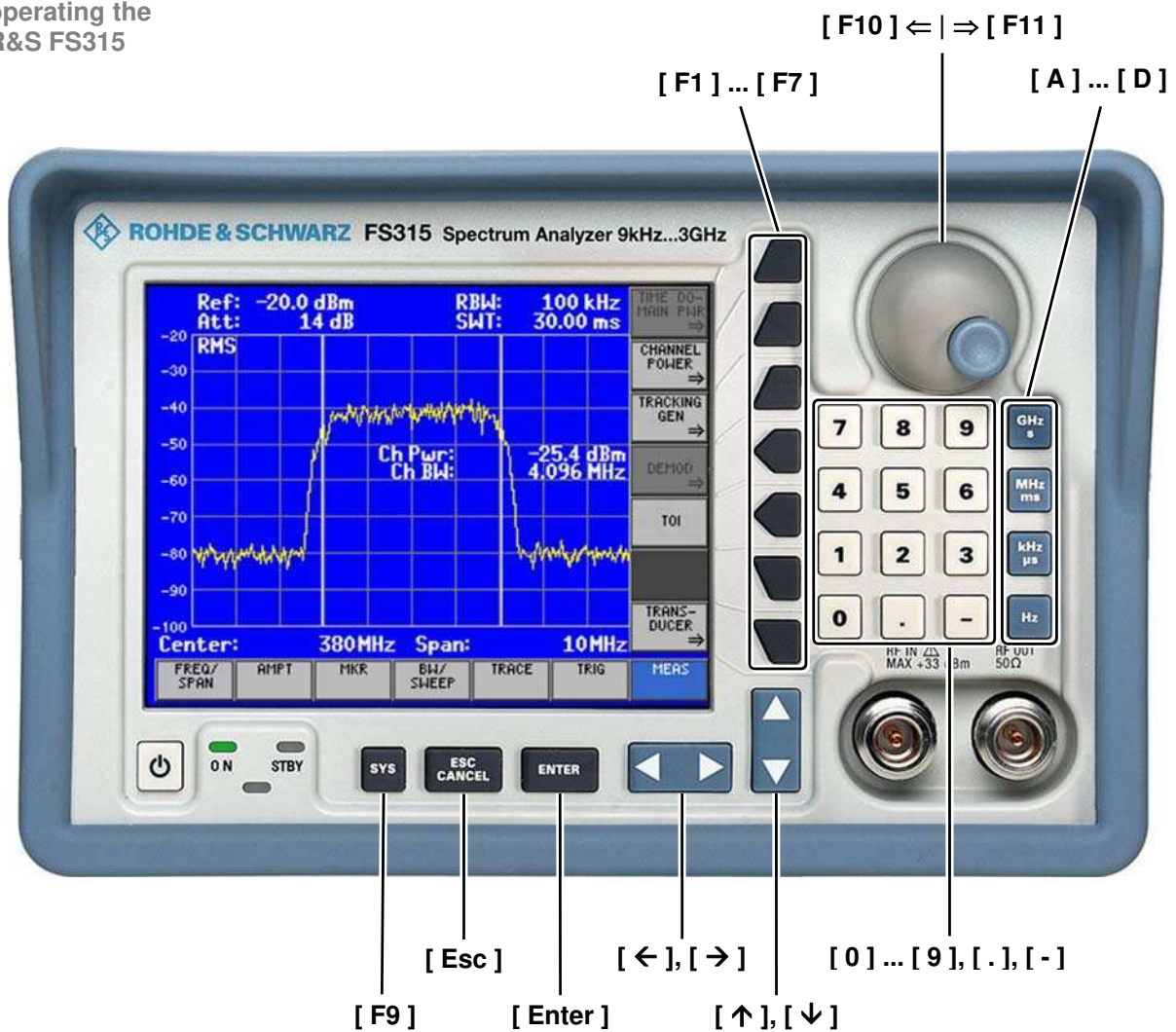

3.8 Connecting a USB Stick



Caution

To ensure that the USB stick is detected by the R&S FS315, the stick must be formatted in the FAT32 file system.

Use

You can connect an external USB stick to the USB device interface [17] at the rear of the R&S FS315. The USB stick is an extension of the internal memory. You can use it to save or load instrument settings, to print into a file on the USB stick or to transfer trace data to a PC. You can also use it to load transducer lists (↗ 6-164) that have been created using the PC software, to the instrument.

4 Getting Started

This chapter	Chapter 4 uses a number of simple measurements to illustrate how to operate the R&S FS315. For the following example, the initial setting for instrument is the default setting (factory). This is set by pressing the PRESET key in the menu (↗ 6-169). The full default setup is described in chapter 6.
Further information	Chapter 5 contains an in-depth explanation of the basic operating steps, for example selecting menus and setting parameters. The layout of the screen and the information displayed on the screen are also described. Chapter 6 describes all the R&S FS315's menus and the associated functions in detail.

4.1 Level and Frequency Measurements

4.1.1 Measurement Task



Caution

The input stage of the R&S FS315 can be destroyed by overloads or DC components. If there is a possibility that the limits specified in the data sheet may be violated, the input must be protected with an attenuator and/or a DC block.

Measurement problem

Determining the level and frequency of a signal is one of the most common measurements a spectrum analyzer is used to make. Often, when making these measurements on an unknown signal, the PRESET settings (factory) are chosen as a suitable initial setup (↗ 6-169).

Solution

The center frequency (CENTER), the SPAN and the MARKER functions play a key role in level and frequency measurements.

4.1.2 Measurement Procedure

Introduction

In this example, a signal with a frequency of 200 MHz and a level of -30 dBm is applied to the RF input [8]. The center frequency and the span are set manually.

Measurement steps

Perform the following steps:

1. Reset the R&S FS315.

- Press the **SYS** key.
- Select **PRESET** in the bottom menu bar using the  cursor keys.
- Press the **PRESET** function key.

2. Apply the signal.

3. Set the center frequency (CENTER) to 200 MHz.

- Select **FREQ/SPAN** in the bottom menu bar using the  cursor keys.
- Press the **CENTER** function key.
- Enter **2 0 0** using the numerical keys. Terminate the entry by pressing the unit key **MHz ms**.

4. Reduce the SPAN to 1 MHz.

- Stay in the **FREQ/SPAN** menu.
- Press the **SPAN** function key.
- Enter **1** from the numerical keys. Terminate the entry by pressing the unit key **MHz ms**.

5. Measure the level and frequency with the marker.

- Select **MKR** in the bottom menu bar using the  cursor keys.
- Press the **MARKER 1** function key.
- Press the **PEAK** function key in the submenu that appears. The

marker jumps to the signal peak. Turn the rotary knob  to change the position of the marker.

6. Frequency measurements with the built-in frequency counter.

- Press the **SIGNAL COUNT** function key in the **MARKER 1** submenu. You can change the resolution of the frequency counter in the same submenu with the **COUNT RESOL** function key.

4.2 Measuring the Frequency Response of a Twoport

4.2.1 Measurement Task

**Caution**

If the DUT is an amplifier, the input stage of the R&S FS315 can be destroyed by overloads or DC components. If there is a possibility that the limits specified in the data sheet could be violated, the input must be protected with a power attenuator and/or a DC block.

It is important to ensure that the set output power of the tracking generator does not exceed the maximum permissible input power of the DUT.

Initial situation

Determining the frequency response of a twoport (e.g. filter, amplifier) is a common measurement task and requires the built-in tracking generator. The measurement described below is performed based on the PRESET settings (factory) of the R&S FS315 (↗ 6-169).

Solution

To measure the frequency response of a twoport, the DUT must be connected between the output of the tracking generator [9] and the input of the spectrum analyzer [8]. With directional DUTs (e.g. amplifiers), make sure that the input and output of the DUT are connected correctly:

- DUT input → Generator output [9]
- DUT output → Analyzer input [8]

You should select a span that will make the transmission characteristics of the DUT visible. If you want the effect of the cables or an attenuator to be omitted from the measurement result, you can perform calibration.





4.2.2 Measurement

Introduction





In the example below, a bandpass filter with a center frequency of 1 GHz and a bandwidth of 80 MHz is to be measured.

Measurement steps Perform the following steps:







1. Reset the instrument.

- Press the  key.
- Select  in the menu bar using the  cursor keys.
- Press the  function key.





2. Set the center frequency (CENTER) to 1 GHz.

- Select  in the menu bar using the  cursor keys.
- Enter  using the numerical keys. Complete the entry by pressing the unit key .

3. Reduce the SPAN to 150 MHz.

- Stay in the  menu.
- Press the  function key.
- Enter    using the numerical keys. Complete the entry by pressing the unit key .

4. Switch on the tracking generator.

- Select  in the menu bar using the  cursor keys.
- Open the  submenu.
- Press the  function key.
- Turn the rotary knob  to select the “Tracking Generator” setting.

5. Calibrate the measurement.

- Use cables to connect the output of the tracking generator [9] to the input of the spectrum analyzer [8].
- Press the  function key.
- Remove the connection between the input and output.

6. Connect the DUT between the N connectors on the front panel.

- Connect the DUT between the N connectors on the front panel. With directional DUTs (e. g. amplifiers), make sure that the input and output of the DUT are connected correctly:



7. Change the position of the trace.

- Press the  function key and change the value using the keyboard, rotary knob or cursor keys.

5 Manual Operating Concept

This chapter Chapter 5 contains an overview of the R&S FS315's basic manual operating concept. This includes a description of the keypad, the screen layout, menu operation and how to set parameters. There is an overview of the menus and functions at the end of this chapter.

Further information Chapter 4 contains a brief introduction that takes you step-by-step through some simple measurements.

Chapter 6 contains an in-depth description of the menu functions.

Chapter 7 contains note for remote control the R&S FS315 via a USB interface.

5.1 Making Entries from the Keypad

Introduction The R&S FS315 is operated using menus in conjunction with a keypad and a rotary knob. The keypad comprises the following sections:

- Numerical keys [12]
- Unit keys [9]
- Cursor keys [6, 7]
- Function keys [13]
- Action keys [4, 5]
- BACK/SYS key [3]

5.1.1 Numerical Keys

Function The numerical keys are used to enter numerical parameters.

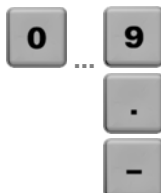

- Inserts one of the digits “0” to “9” at the cursor position.
- Inserts a decimal point “.” at the cursor position.
- Inserts a minus sign “-” at the cursor position.

5.1.2 Unit Keys

Function The unit keys are used to assign the appropriate unit to the number that has been entered, simultaneously terminating the entry.



- Assigns **GHz** when a **frequency setting** is being made
- Assigns **s** when a **time setting** is being made



- Assigns **MHz** when a **frequency setting** is being made
- Assigns **ms** when a **time setting** is being made



- Assigns **kHz** when a **frequency setting** is being made
- Assigns **μs** when a **time setting** is being made



- Assigns **Hz** when a **frequency setting** is being made



Note

In the case of all other entries, the unit keys assume the same function as the Enter key. (↗ 5-49).

5.1.3 Rotary Knob

Function

As well as the numerical keys and the cursor keys, the rotary knob is also used to set parameters.



The rotary knob has several functions:

- **Incrementing** (turn clockwise) or **decrementing** (turn counter-clockwise) numerical instrument parameters using a specified step size.
- **Positioning** markers, limits, etc on the screen.

5.1.4 Cursor Keys

Function

As well as the numerical keys and the rotary knob, the cursor keys are also used for entering parameters and to navigate through the menus.



The cursor keys have the following functions:

- **Navigating** through menus and selection fields
- The ◀ or ▶ cursor keys **move** the cursor to the position you want within the numerical editing line.
- The ▼ or ▲ cursor keys **increment** or **decrement** numerical parameter entries.

5.1.5 Function Keys

Function

In the function area, various instrument functions are displayed depending on which menu has been selected.

The displayed instrument functions are assigned to the seven function keys down the right side of the screen. This means that each function key can have a variety of functions (↗ 5-52).



When a function key is pressed, various responses can be elicited:

- Immediate activation of a function or toggling between settings
- Entry of a value or selection of a setting/function
- Confirmation of a new setting and opening of a new menu item
- Branching to a submenu

5.1.6 Action Keys

Function

The action keys are used to complete menu-guided settings.



- With numerical entries, pressing this key completes an entry without closing the entry field.
- With a selection field, the setting is adopted and the selection window is closed.
- Pressing this key assigns Hz as the unit of measurement when a frequency setting is being made.

Note: Pressing a unit key will also complete the entry of setting data.



- Pressing this key closes the entry field or selection field after data has been entered. The new value is set.

5.1.7 BACK/SYS Key

Function 1

If the **entry field is closed** the BACK/SYS [3] key will open or close the system menu (SYS).

- SYS**
- When you press the key, the measuring menu is blanked out and replaced by the SYS menu. Other functions are assigned to the function keys [13] and the measurement diagram is replaced by the system parameters (↗ 6-167).
 - By repeatedly pressing the key, you can quit the SYS menu and accept the new settings.

Function 2

If the **entry field is open** the BACK/SYS [3] key can be used to correct numerical inputs.

- BACK**
- If the parameter entry field is open, the key functions as a BACK key (i.e. a value entered using the keyboard can be deleted again one character at a time). The key has no effect if the value in an entry field was changed using the cursor keys or rotary knob.

5.2 Screen Display

Introduction

The screen [14] provides on-going information about events and the parameters associated with the selected measurement functions.

The display mode for the measurement results, the lettering of the function keys and the type of menu all depend on the current settings.

Screen layout

The screen is divided into three areas:

- I Diagram area
- II Menu area
- III Function area

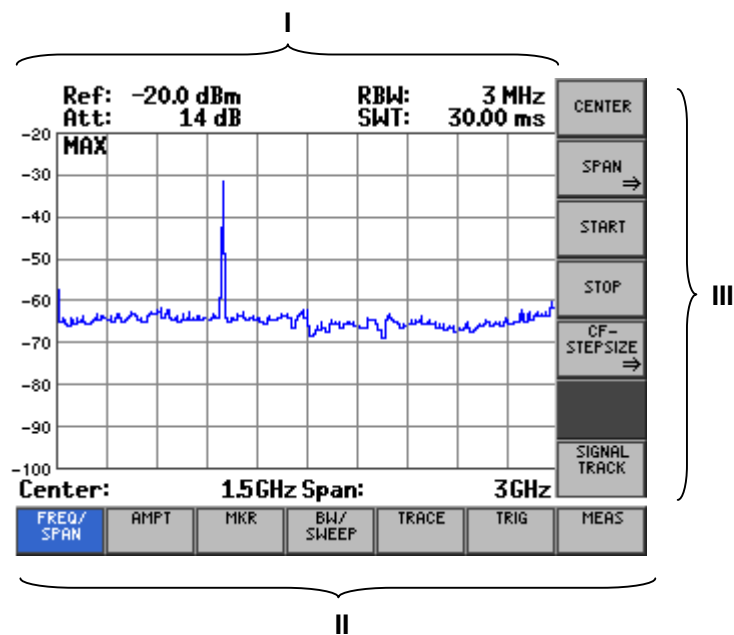

5.2.1 Diagram Area

Displays in the diagram area

The diagram area contains:

- Measurement diagrams and the associated scales (h) and traces (e)
- Measured value displays, e. g. display line (d) and markers (c)
- Parameter field (b) and status displays (a)
- Selection fields and entry fields that come up on the screen (g)
- Error messages that come up on the screen (f)

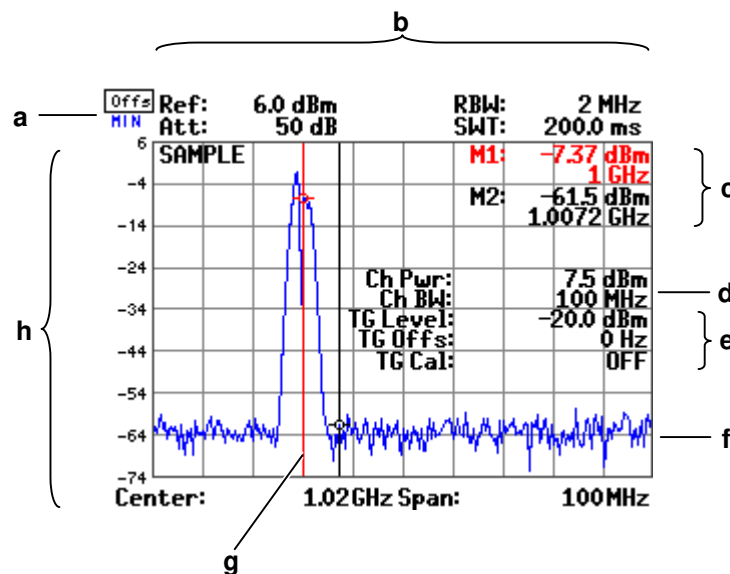

Status display

The status display provides the following information:

- Offs** - level offset is on
MIN - current trace display mode, e. g. min hold

Parameter field

The following are displayed in the parameter field:

- Ref:** - upper diagram limit (reference level)
Att: - RF input attenuation
RBW: - current resolution bandwidth
SWT: - sweep speed

Measurement diagram

A 10 x 8 grid is superimposed on the diagram area to make it easier to analyze traces.

The following settings are displayed in the measurement diagram:

- SAMPLE** - selected detector (Min Peak, Max Peak, Sample, RMS, Average)
M1: - marker 1 plus marker position and level
M2: - marker 2 plus marker position and level
CH Pwr: - channel power at set channel bandwidth
TG: - level, frequency and calibration of tracking generator

5.2.2 Menu Area

Menu display Menus for setting the measurement parameters and the measurement functions are displayed in the menu area. The selected menu is highlighted, e.g. **FREQ/SPAN** menu:

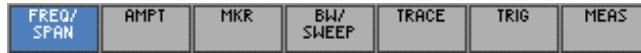

5.2.3 Function Area

Displaying the current assignment for the function keys

When a menu is selected, the associated instrument functions are displayed in the function area.

The displayed instrument functions are assigned to the seven function keys down the right-hand side of the screen. If a key in the function area does not have any lettering, the key has not been assigned a function in the menu in question. If a key has lettering, but not in full brightness, the key has temporarily (current setting) not been assigned a function.

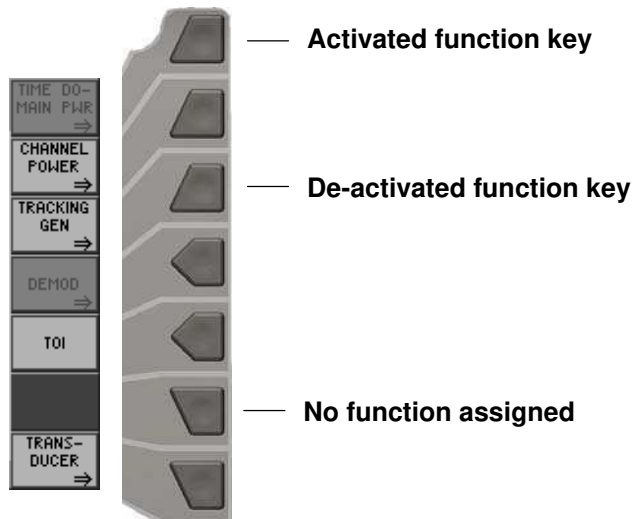

5.3 Calling and Changing Menus

Introduction

Operating the R&S FS315 is menu-guided. All the menus used to set the measurement parameters and measurement functions are displayed in the menu area. The instrument functions associated with any menu you select are displayed in the function area.

Pressing a function key has one of the following effects:

- Direct execution of an instrument function
- Opening of entry or selection windows
- Opening of submenus

The ◀ or ▶ cursor keys [6] are used for menu navigation.

Calling or changing menus

1. Select a **menu**, e.g. MKR, with the ◀ or ▶ [6] **cursor keys**.

The menu name is highlighted and the appropriate function is assigned to the function keys [13].

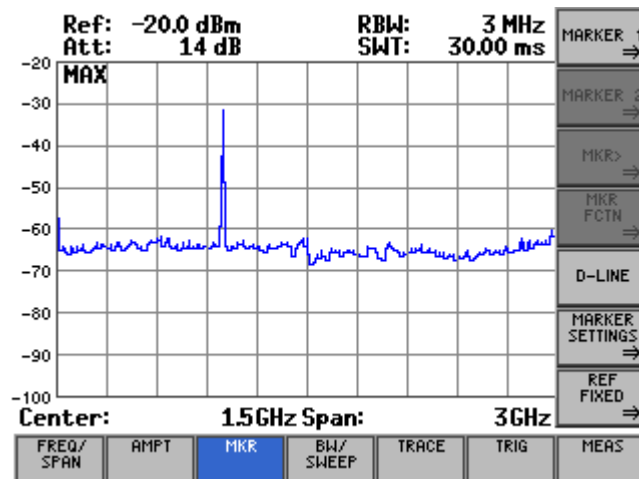

Note

A double arrow ⇒ pointing to a function key, e.g. MARKER 1 ⇒, tells you that pressing this key will call a submenu.

Calling/quitting submenus

- Press the **MARKER 1** function key in the **MKR** menu.

The MARKER 1 submenu opens and the new functions are assigned to the function keys [13].

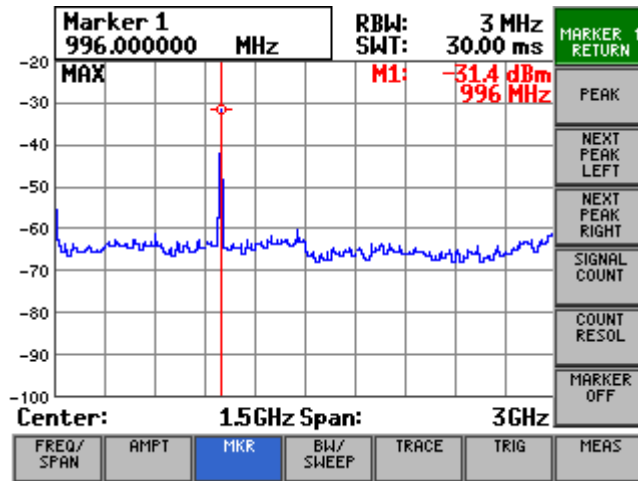

- Press the **MARKER 1 RETURN** function key in the **MARKER 1** submenu.

The submenu is closed and the previous functions remain assigned to the function keys [13].

5.4 Setting Parameters

There is a choice of methods

Parameters can be set in a number of ways:

- Direct selection of an instrument function (function key)
- Selecting settings from selection fields
- Entering numerical parameters in entry fields

The numerical keys [12], the unit keys [9], the rotary knob [11], the cursor keys [6, 7] and the action keys [4, 5] can all be used to select and enter instrument parameters.

5.4.1 Direct Selection of Instrument Functions

Introduction

When you select a menu, various instrument functions are displayed in the function area. Some instrument functions can be set directly by pressing a function key.

The function key you select is highlighted.

e.g. :
Displaying marker 1
(↗ 6-95)

1. Press the **PEAK** function key in the **MARKER 1** submenu.

Marker 1 is turned on and placed on the trace maximum. The M1 marker values are displayed in the parameter field.

2. Press the **NEXT PEAK RIGHT** function key in the **MARKER 1** submenu.

Marker 1 moves from the maximum value of the trace to the next lowest value to the right of the maximum value.

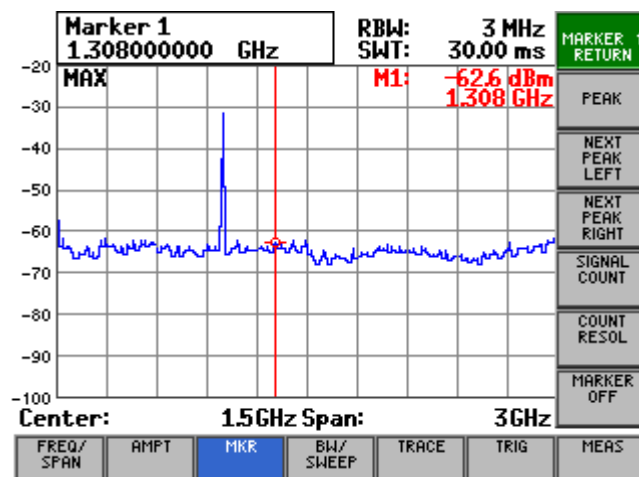

3. Press the **MARKER OFF** function key in the **MARKER 1** submenu.

Marker 1 disappears from the diagram area and the M1 marker values are blanked out.

5.4.2 Selecting Settings

Introduction

When you select a menu, a number of instrument functions are displayed in the function area. If certain function keys are then pressed, a selection field is displayed in the diagram area. You can then choose and activate any of the settings offered for selection.

The function key you select is highlighted.

e.g. :
Setting the level
display range
(↗ 6-86)

1. Press the **RANGE** function key in the **AMPT** menu.

A selection field containing the available settings is displayed. The default setting is "80 dB".

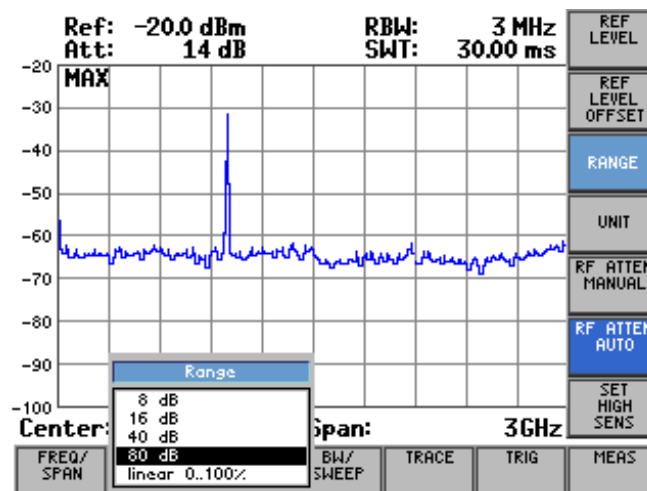

2. Select a level display range with **rotary knob** [11].
3. Press the **ENTER key** [5] to close the selection field.

The new setting is saved.

If you want to keep the old setting, close the entry field with the **ESC/CANCEL key** [4].

Note

If there are more than five options, a scroll bar is displayed on the right next to the selection field. At any one time, only five options are displayed on the screen.

5.4.3 Entering Numerical Parameters

Introduction

When you select a menu, a number of instrument functions will be displayed in the function area. If you press certain function keys, an entry field will be displayed in the diagram area.

The function key you select is highlighted.

There are two ways of entering numerical parameters:

- **Entry** of a number with the **numerical keys**
- **Entry** of a number with the **cursor keys** and **rotary knob**

The entry with the cursor keys and rotary knob is useful if you only have a rough idea of what the measurement parameters should be. As the screen is continuously updated as the value is varied, a search is possible.

5.4.3.1 Entry with the Numerical Keys

e.g. :
Setting the
center frequency
(↗ 6-73)

1. Press the **CENTER** function key in the **FREQ/SPAN** menu.

An entry field containing the current setting is displayed in the top left-hand corner.

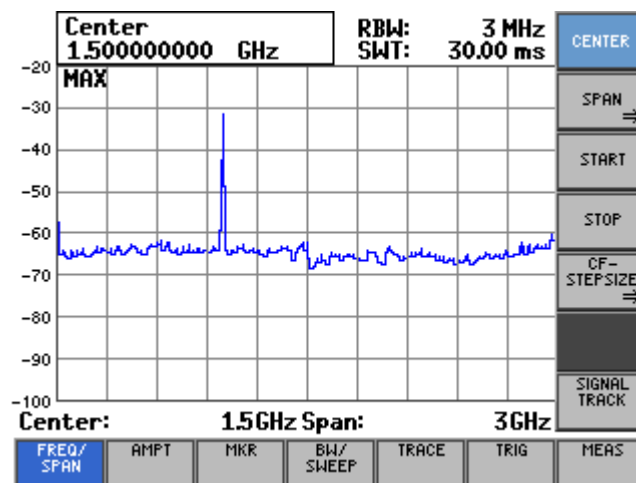

Entering
a new value

2. Overwrite the old value, e.g. **1234 MHz**, with the **numerical keys** [12].



The frequency is adopted immediately in the selected unit and set by the R&S FS315. The entry window remains open and the value can be overwritten by a new value at any time.

Note: If you press ENTER instead of a unit key, the smallest unit will be assigned (e.g. Hz).

- Correcting an entry** 3. Press the **SYS/BACK key** [3] repeatedly until you have deleted the incorrect digit (e.g. the second two in 1.224 MHz).

2 ×  ⇒

Center	
12	MHz

Then enter the correct final digits.

  ⇒

Center	
1234	MHz

- Terminating entries** 4. Press the **ESC/CANCEL key** [4] to abort the entry. The **old value** is retained. The entry window is closed.
- Invalid parameter entry**
- Invalid parameter entry (e.g. 1234 GHz): If the entered value is outside the permissible range, the largest or smallest permissible value is set and a message containing the value range appears below the entry window.

Out of Range! 500 Hz ... 2,9999995 GHz
--



Note

When numbers are displayed, only the digit sequences 1 to 999 appear before the decimal point. In other words, if the digit sequence <5000> and the unit <kHz> are entered, <5 MHz> appears in the display. Trailing zeros will be eliminated in the display area.

5.4.3.2 Entry using the Cursor Keys and the Rotary Knob

e.g. :
Setting the span
(↗ 6-73)

1. Press the **SPAN** function key in the **FREQ/SPAN** menu.

An entry field containing the current setting appears in the top left-hand corner.

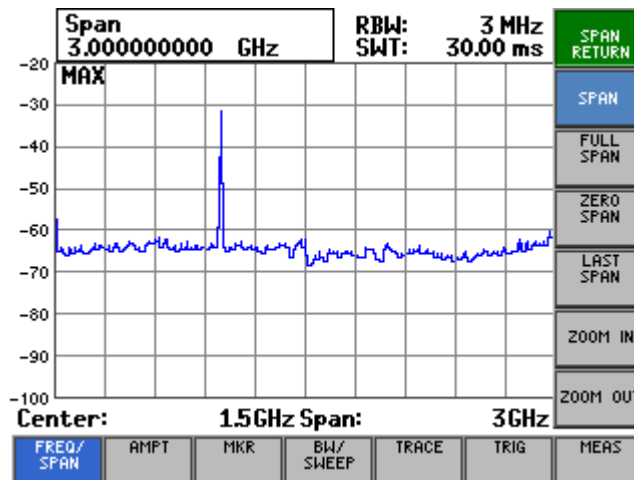

Entering
a new value

The step width for the change is different for the cursor keys and rotary knob. The cursor keys change the value in large steps, whereas the rotary knob allows a more precise setting. The span is changed in the following preset step widths:

- **Cursor keys:** Steps 1-2-5-10
- **Rotary knob:** The third digit is changed.

- 2a. Press the **cursor key** ▾ [7] once so that a span of 2 GHz is displayed.

Pressing the ▲ cursor key once increments the value by one; pressing the ▾ cursor key once decrements the value by one.

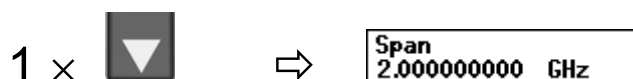

- 2b. Turn the **rotary knob** [11] to left until you obtain the value you want, e.g. 1.95 GHz.

Turning clockwise increases the value; turning counter-clockwise reduces the value.

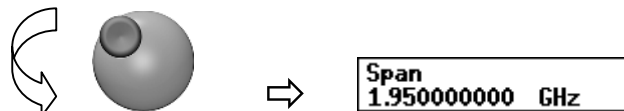

Note

When you enter the center frequency, you can specify the step width of the rotary knob. (↗ 6-80). In this case, the value is incremented or decremented in accordance with the specified step width, with the cursor always moving to the highest value, irrespective of its earlier position.

Terminating entries

3. Press the **ESC/CANCEL key** [4] to abort the entry.
The **old value** is retained. The entry window is closed.

Invalid parameter entry

If the limit value is reached, the numeric value in the entry window remains the same and is neither increased nor decreased. No error message is issued.

**Note**



















When numbers are displayed, only the digit sequences 1 to 999 appear before the decimal point. In other words, if the digit sequence <5000> and the unit <kHz> are entered, <5 MHz> appears in the display. Trailing zeros will be eliminated in the display area.

5.5 Overview of all Menus and Functions

5.5.1 Spectrum Analyzer

5.5.1.1 FREQ/SPAN Menu

Function key assignment

	Entering the center frequency	(↗ 6-73)
	Open submenu: Display modes for the frequency axis	
	Quitting the submenu	
	Entering the span	(↗ 6-75)
	Displaying the whole frequency range	(↗ 6-76)
	Switching over to the ZERO SPAN	(↗ 6-77)
	Restoring the previous setting	(↗ 6-77)
	Reducing the span	(↗ 6-78)
	Increasing the span	(↗ 6-78)
	Entering the start frequency	(↗ 6-79)
	Entering the stop frequency	(↗ 6-79)
	Open submenu: Entering the step width of the center frequency	
	Quitting the submenu	
	Setting the step size manually	(↗ 6-81)
	Setting the step size automatically	(↗ 6-81)
	Setting the step size to the center frequency	(↗ 6-81)
	Setting the step size to the marker frequency	(↗ 6-81)
	Signal tracking	(↗ 6-82)

5.5.1.2 AMPT Menu

Function key assignment

REF LEVEL	Entering the reference level	(↗ 6-84)
REF LEVEL OFFSET	Entering a level offset	(↗ 6-85)
RANGE	Selecting the level display range	(↗ 6-86)
UNIT	Selecting a unit for the level display	(↗ 6-87)
RF ATTEN MANUAL	Setting the RF input attenuation manually	(↗ 6-89)
RF ATTEN AUTO	Setting the RF input attenuation automatically	(↗ 6-90)
SET HIGH SENS	Selecting the setting High Sensitivity	(↗ 6-92)

5.5.1.3 MKR Menu























Function key assignment

MARKER 1 ⇒	Open submenu: Activate marker 1	
MARKER 1 RETURN	Quitting the submenu	
PEAK	Place marker 1 on the trace maximum	(↗ 6-95)
NEXT PEAK LEFT	Place marker 1 on the next trace maximum to the left	(↗ 6-95)
NEXT PEAK RIGHT	Place marker 1 on the next trace maximum to the right	(↗ 6-95)
SIGNAL COUNT	Measure the signal frequency: Start measurement	(↗ 6-97)
COUNT RESOL	Measure signal frequency: Set resolution	(↗ 6-97)
MARKER OFF	De-activate marker 1	(↗ 6-95)
MARKER 2 ⇒	Open submenu: Activate marker 2	
MARKER 2 RETURN	Quitting the submenu	
PEAK	Place marker 2 on the trace maximum	(↗ 6-99)
NEXT PEAK LEFT	Place marker 2 on the next trace maximum to the left	(↗ 6-99)
NEXT PEAK RIGHT	Place marker 2 on the next trace maximum to the right	(↗ 6-99)
MARKER NORM	Set marker 2 as a normal marker (NORM)	(↗ 6-100)
MARKER DELTA	Set marker 2 as a delta marker (DELTA)	(↗ 6-100)
MARKER OFF	De-activate marker 2	(↗ 6-99)

<div style="border: 1px solid black; padding: 2px; width: fit-content;">MKR> ⇒</div>	<p>Open submenu: Accepting marker values as settings</p>		
	<div style="border: 1px solid black; padding: 2px; width: fit-content;">MKR> RETURN</div>	Quitting the submenu	
	<div style="border: 1px solid black; padding: 2px; width: fit-content;">CENTER = MKR FREQ</div>	Set the center frequency to the marker frequency	(↗ 6-102)
	<div style="border: 1px solid black; padding: 2px; width: fit-content;">REF LVL = MKR LVL</div>	Set the marker level as a reference level	(↗ 6-102)
	<div style="border: 1px solid black; padding: 2px; width: fit-content;">MKR -> CF STEP SIZE</div>	Set the step size for entering the center frequency to the marker frequency	(↗ 6-104)
<div style="border: 1px solid black; padding: 2px; width: fit-content;">MKR FCTN ⇒</div>	<p>Open submenu: Marker measurement functions</p>		
	<div style="border: 1px solid black; padding: 2px; width: fit-content;">MKR FCTN RETURN</div>	Quitting the submenu	
	<div style="border: 1px solid black; padding: 2px; width: fit-content;">NOISE MARKER</div>	Measuring noise power density	(↗ 6-106)
	<div style="border: 1px solid black; padding: 2px; width: fit-content;">N dB DOWN</div>	Measuring signal bandwidth	(↗ 6-108)
<div style="border: 1px solid black; padding: 2px; width: fit-content;">D-LINE</div>	Bring display line up on screen		(↗ 6-110)
<div style="border: 1px solid black; padding: 2px; width: fit-content;">MARKER SETTINGS ⇒</div>	<p>Open submenu: Search criterion of functions NEXT PEAK LEFT/RIGHT</p>		
	<div style="border: 1px solid black; padding: 2px; width: fit-content;">MARKER SETTINGS RETURN</div>	Quitting the submenu	
	<div style="border: 1px solid black; padding: 2px; width: fit-content;">PEAK EXCURS</div>	Entering the peak excursion	(↗ 6-112)
<div style="border: 1px solid black; padding: 2px; width: fit-content;">REF FIXED ⇒</div>	<p>Open submenu: Reference points for measuring level differences</p>		
	<div style="border: 1px solid black; padding: 2px; width: fit-content;">REF FIXED RETURN</div>	Quitting the submenu	
	<div style="border: 1px solid black; padding: 2px; width: fit-content;">REF FIXED ON</div>	Activating the entry of arbitrary reference points	(↗ 6-115)
	<div style="border: 1px solid black; padding: 2px; width: fit-content;">REF FIXED OFF</div>	Using M1 marker values as a reference point	(↗ 6-115)
	<div style="border: 1px solid black; padding: 2px; width: fit-content;">REF POINT LEVEL</div>	Entering the reference-point level	(↗ 6-115)
	<div style="border: 1px solid black; padding: 2px; width: fit-content;">REF POINT FREQ</div>	Entering the reference-point frequency	(↗ 6-115)
	<div style="border: 1px solid black; padding: 2px; width: fit-content;">REF POINT TIME</div>	Entering the reference-point time	(↗ 6-115)















5.5.1.4 BW/SWEEP Menu

Function key assignment

	Setting the resolution bandwidth manually	(↗ 6-119)
	Activating automatic resolution bandwidth setting	(↗ 6-119)
	Setting the video bandwidth manually	(↗ 6-120)
	Activating automatic video bandwidth setting	(↗ 6-120)
	Open submenu: Setting the RBW/VBW coupling ratio	
	Quitting the submenu	
	Setting the coupling ratio RBW/VBW manually	(↗ 6-122)
	Activating the default setting for the coupling ratio RBW/VBW	(↗ 6-122)
	Switching over the coupling RBW/SPAN to low noise	(↗ 6-123)
	Open submenu: Setting the sweep time	
	Quitting the submenu	
	Starting a continuous frequency sweep	(↗ 6-125)
	Performing an n-times sweep	(↗ 6-125)
	Setting the number of sweeps	(↗ 6-125)
	Repeating n-times sweeps	(↗ 6-126)
	Setting the sweep time manually	(↗ 6-126)
	Activating automatic sweep-time setting	(↗ 6-126)
	Open submenu: Evaluating the individual pixels of a trace	
	PEAK detector is active	(↗ 6-129)
	SAMPLE detector is active	(↗ 6-129)
	RMS detector is active	(↗ 6-129)
	AVERAGE detector is active	(↗ 6-129)





5.5.1.5 TRACE Menu

Function key assignment

	Open submenu: Selecting the active trace	
	Quitting the submenu	
	Turning on and activating Trace 1	(↗ 6-133)
	Turning on and activating Trace 2	(↗ 6-133)
	Trace display mode: Overwrite mode	(↗ 6-135)
	Trace display mode: Min./Max. hold	(↗ 6-135)
	Trace display mode: Averaging	(↗ 6-135)
	Freezing the trace	(↗ 6-135)
	Blanking out the trace	(↗ 6-135)
	Open submenu: Trace difference	
	Quitting the submenu	
	Turning on the trace-difference mode	(↗ 6-139)
	Repositioning Trace 1 (result)	(↗ 6-139)
	Turning off the trace-difference mode	(↗ 6-139)

5.5.1.6 TRIG Menu

Function key assignment

	Free-running measurements	(↗ 6-141)
	Triggering by an external TTL signal	(↗ 6-142)
	Triggering by the display level	(↗ 6-141)
	Selecting the trigger edge	(↗ 6-142)
	Entering a trigger offset	(↗ 6-142)

5.5.1.7 MEAS Menu

Function key assignment



Open submenu:

Measure the power in the time domain (ZERO SPAN)



Quitting the submenu



Output the peak value within the section (↗ 6-145)



Output the mean value within the section (↗ 6-145)



Output the mean square within the time domain (↗ 6-145)



Insert a vertical line to limit the lower (left) part of a section (↗ 6-145)



Insert a vertical line to limit the upper (right) part of a section (↗ 6-145)



Switch off the power measurement (↗ 6-145)



Open submenu:

Measuring the channel power



Quitting the submenu



Measure the channel power (↗ 6-149)



Set the channel bandwidth (↗ 6-149)



Measure the occupied bandwidth (↗ 6-151)



Set the power bandwidth (↗ 6-151)



Open submenu:

Configuring the built-in generator



Quitting the submenu



Enter the output level (↗ 6-159)



Enter the frequency or frequency offset (↗ 6-159)



Calibrate the test setup and activate the calibration (↗ 6-154)



Enter the reference position (↗ 6-154)



Enter the level offset (↗ 6-154)



Select the tracking generator operating mode (↗ 6-154)



**Open submenu:
AM/FM demodulation**

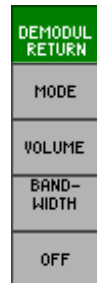

- Quitting the submenu
- Select the AM/FM demodulation mode (↗ 6-161)
- Adjust the headphone volume (↗ 6-161)
- Set the demodulation bandwidth (↗ 6-161)
- Switching off the AM/FM demodulation (↗ 6-161)



- Measure the third-order intercept point (↗ 6-162)



**Open submenu:
Activating the transducer function**



- Quitting the submenu
- Load a transducer set from a USB stick (↗ 6-165)
- Load a transducer set from the internal memory (↗ 6-165)
- Save a transducer set to the internal memory (↗ 6-165)
- Delete a transducer set from the internal memory (↗ 6-165)
- Deactivate a transducer set (↗ 6-165)

5.5.2 SYSTEM Functions

5.5.2.1 PRESET Menu

Function key assignment

PRESET	Calls an instrument default setting	(↗ 6-170)
PRESET SETTINGS	Selects an instrument default setting	(↗ 6-170)

5.5.2.2 STATUS Menu

Function key assignment

ANALYZER	Spectrum analyzer settings	(↗ 6-171)
POWER	Settings for the channel power measurement	(↗ 6-173)
TRACKING GEN	Tracking generator settings	(↗ 6-174)
DEMOD	Demodulation settings	(↗ 6-175)
TRANS-DUCER	Settings for transducer sets	(↗ 6-176)

5.5.2.3 FILE Menu

Function key assignment

SAVE	Saves a user-defined setting	(↗ 6-178)
RECALL	Loads a user-defined setting	(↗ 6-178)
PRINT	Prints out a screenshot	(↗ 6-180)

5.5.2.4 CONFIG Menu

Function key assignment

DATE/TIME	Sets the date and time	(↗ 6-185)
REF	Selects an internal or external reference source	(↗ 6-187)
INTERFACE	Configures the instrument interfaces	(↗ 6-188)
SCREEN	Sets the screen saver mode	(↗ 6-190)
MONITOR	Selects an internal or external monitor	(↗ 6-193)
FUNCTIONS	Enable new functions	

5.5.2.5 SERVICE Menu

Function key
assignment



Performs a selftest

(↗ 6-194)

5.5.2.6 INFO Menu

Function key
assignment

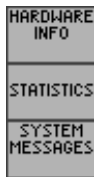

Displays module data

(↗ 6-196)

Displays instrument statistics

(↗ 6-196)

Displays system messages

(↗ 6-197)

6 Using the R&S FS315

This chapter All the spectrum analyzer functions and their uses are fully described in chapter 6. The order in which the menus are described follows that of the procedures for configuring and starting measurements:

- R&S FS315 default settings
- Setting measurement parameters
- Selecting and configuring measurement functions

Further information The operating concept is explained in chapter 5, which also contains an overview of the menus and functions. The index at the end of this manual will also help you find the information you want.

6.1 R&S FS315 Factory Settings

Switching on for the first time When you switch on the R&S FS315 (➤ 3-39), the settings you were using when the instrument was last switched off are restored. When you switch on for the first time, the factory default settings are activated:

	Parameter	Setting
Frequency axis	Center frequency (CENTER)	1.5 GHz
	Frequency span (SPAN)	3 GHz
	Step size for center frequency	150 MHz
Level axis	Reference level (REF LEVEL)	-20 dBm
	Level offset (REF LEVEL OFFSET)	0 dB
	Level range (RANGE)	80 dB
	Level unit (UNIT)	dBm
RF input	Input attenuation (RF ATTEN)	AUTO (NORMAL)
Bandwidth	Sweep time (SWEEP TIME)	AUTO
	Resolution bandwidth (RES BW)	AUTO (1 MHz)
	Video bandwidth (VIDEO BW)	AUTO (1 MHz)
Frequency sweep	Sweep	CONT SWEEP
Trace	Trace	CLEAR/WRITE
Trigger	Trigger	FREE RUN
Markers	Marker 1 and marker 2	OFF
Tracking Generator (Frequency Fixed)	Mode	OFF
	Output level	-20 dBm
(Tracking Mode)	Output frequency	1.5 GHz
	Output level	-20 dBm
	Referency position	100 %
	Trace Offset	0 dB



Note

The factory default setting is stored in non-volatile memory in the R&S FS315 and can be reloaded at any time (➤ 6-169).

6.2 Spectrum Analyzer

Introduction

The R&S FS315 measures signal spectra over the selected frequency range using the selected resolution bandwidth and sweep. The time characteristic of the amplitude at the set frequency is displayed in zero span.

User interface

When the R&S FS315 is switched on and the selftest passed, the spectrum analyzer's user interface is activated. The following is displayed on the screen [14]:

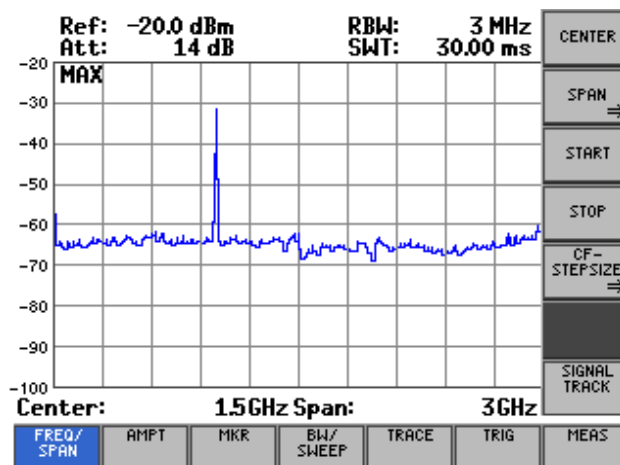

Menus for configuring and starting measurements

The menus used to set the spectrum analyzer are displayed in the menu area. The order of the menus mirrors that of the procedure for configuring and starting measurements:

FREQ/ SPAN	Selecting the frequency span (setting the x axis in the diagram area)	(↗ 6-72)
AMPT	Setting the level axis and the RF input (setting the y axis in the diagram area)	(↗ 6-83)
MKR	Signal analysis with marker functions	(↗ 6-93)
BW/ SWEEP	Setting the bandwidths and the sweep time	(↗ 6-118)
TRACE	Displaying the trace	(↗ 6-131)
TRIG	Triggering the measurement	(↗ 6-140)
MEAS	Measurement functions	(↗ 6-143)

6.2.1 Selecting the Frequency Span (FREQ/SPAN Menu)

What the settings are for

Use the FREQ/SPAN menu to specify the frequency range.

Selecting the FREQ/SPAN menu

- Select the **FREQ/SPAN** menu using the ◀ or ▶ cursor key [6].

The menu name is highlighted and the appropriate functions are assigned to the function keys [13].

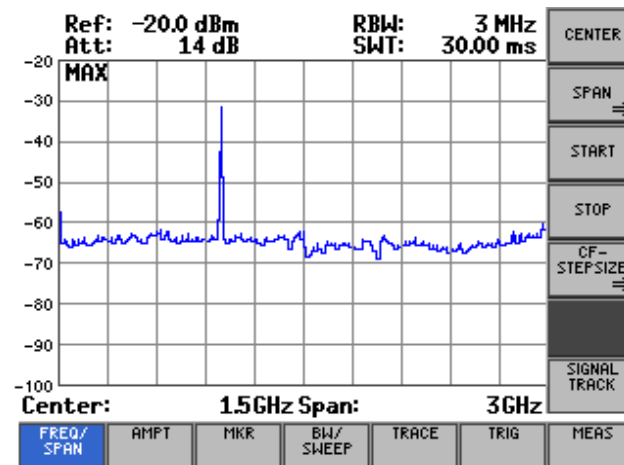

Function key assignment

1st variant: Setting the frequency range



Enter the center frequency

(↗ 6-73)



Open submenu:

Enter the SPAN

(↗ 6-75)

2nd variant: Setting the frequency range



Enter the START frequencies

(↗ 6-79)



Enter the STOP frequencies

(↗ 6-79)



Open submenu:

Entering the step width of the center frequency

(↗ 6-80)



Switching on/off signal tracking

(↗ 6-82)

6.2.1.1 Entering the Center Frequency

Use

If you know the frequency of the signal you want to measure, you can set the x axis of the diagram area accordingly. Enter the signal frequency as the center frequency (CENTER) and specify a SPAN (↗ 6-75).

Entering the center frequency

1. Press the **CENTER** function key in the **FREQ/SPAN** menu.

An entry field containing the current setting is displayed in the top left-hand corner.

Center
1.50000000 GHz

2. Enter the new value (↗ 5-57).

The entry range for the center frequency is:

$$500 \text{ Hz} \leq \text{Center} \leq 2.9999995 \text{ GHz}$$

The new setting is saved and displayed in the diagram area.

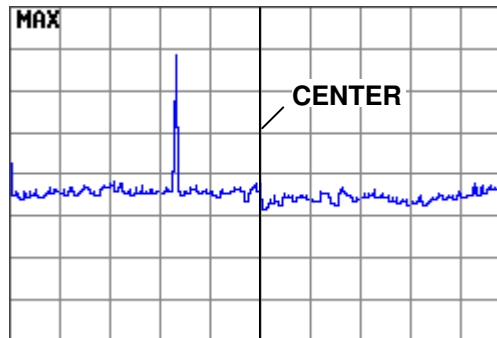

6.2.1.2 Frequency-Axis Display Modes

What the settings are for

The frequency axis (x axis) can be displayed in a number of ways. Using the SPAN SETTINGS submenu, you can display the whole frequency range, zoom in on subranges of the frequency axis or project the diagram area onto the whole of the screen, if and when you require.

If you switchover to the time domain (ZERO SPAN), you can display the amplitude of the carrier signal as functions of time.





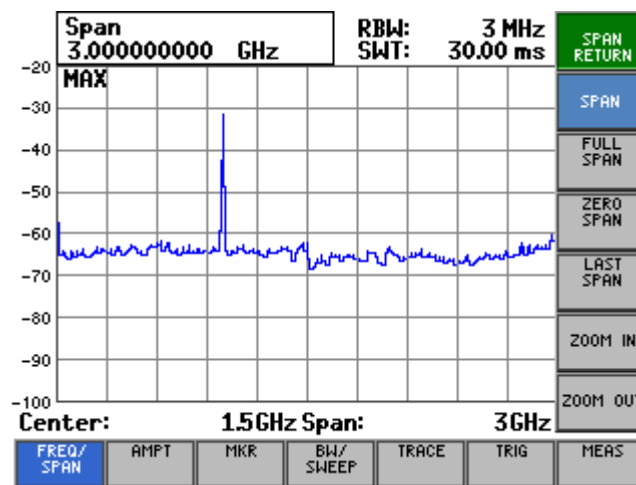

Selecting the SPAN SETTINGS submenu

- Press the  function key in the  menu.

The submenu opens and the appropriate functions are assigned to the function keys [13].



Function key assignment

	Quitting the submenu	
	Enter the SPAN	(↗ 6-75)
	Displaying the whole frequency range	(↗ 6-76)
	Switching over to the ZERO SPAN	(↗ 6-77)
	Restoring the previous setting	(↗ 6-77)
	Zoom function: Reducing the span	(↗ 6-78)
	Zoom function: Increasing the span	(↗ 6-78)

6.2.1.2.1 Entering the Span

Use If you know the frequency of the signal you want to measure, you can set the SPAN.

Setting the span

1. Press the **SPAN** function key in the **FREQ/SPAN** menu.

An entry field containing the current setting is displayed in the top left-hand corner.

Span
3.000000000 GHz

2. Enter the new value (↗ 5-57).

The span entry range is:

$$1 \text{ kHz} \leq \text{Span} \leq 3 \text{ GHz}$$

The new setting is saved and displayed in the diagram area. The grid lines associated with the frequency axis represent 1/10 of the current span.

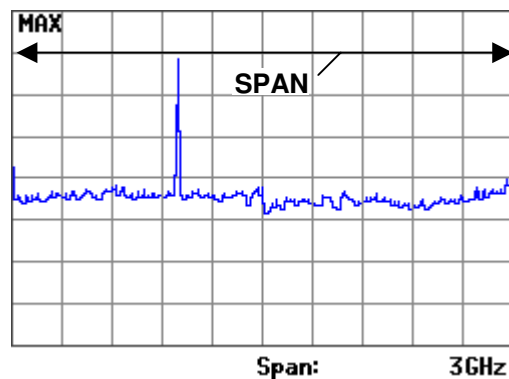

6.2.1.2.2 Displaying the Whole Frequency Range

Use

If you do not know the frequency of the signal to be investigated, you can display the R&S FS315's whole frequency range along the x axis of the diagram area. You can then systematically reduce the span to the appropriate size (➤ 6-75).

The whole frequency range display can also be used to swap backwards and forwards between an overview measurement (FULL SPAN) and a detailed measurement (LAST SPAN, e.g. center frequency and span set manually).

Displaying the whole frequency range

1. Press the **FULL SPAN** function key in the **SPAN** menu.

The old setting is saved and the R&S FS315's whole frequency range is displayed in the diagram area.

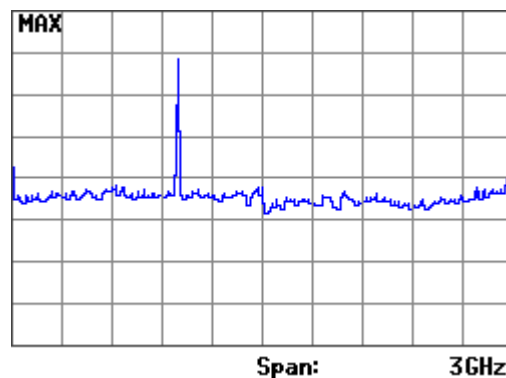

Displaying the last span

2. Press the **LAST SPAN** function key in the **SPAN** menu.

The last span setting is displayed in the diagram area, e.g. 1 MHz:

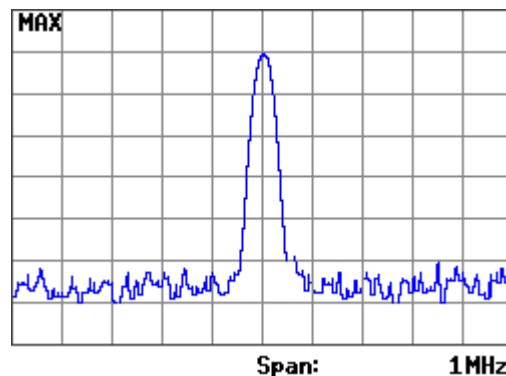

Note

The last span is restored if and only if the span is > 0, in other words, the time domain (ZERO SPAN) will not be selected automatically.

6.2.1.2.3 Switching over to the ZERO SPAN

Use The amplitude of a particular signal component in the frequency spectrum can be displayed as a function of time. To activate this mode, enter the frequency of the signal component as the center frequency. You can then define the x axis to be the time axis.

Specifying the signal component

1. Press the **CENTER** function key in the **FREQ/SPAN** menu.

An entry field containing the current setting is displayed in the top left-hand corner.

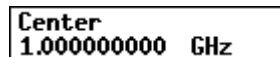

2. Enter the frequency of the signal component you want to display in the time domain (↗ 6-73).

Switching over to the ZERO SPAN

3. Press the **ZERO SPAN** function key in the **SPAN** submenu.

The x axis becomes the time axis and the signal amplitude at the current center frequency is displayed as a function of time (current sweep time). The grid line spacing represents 1/10 of the current sweep time (↗ 6-124).

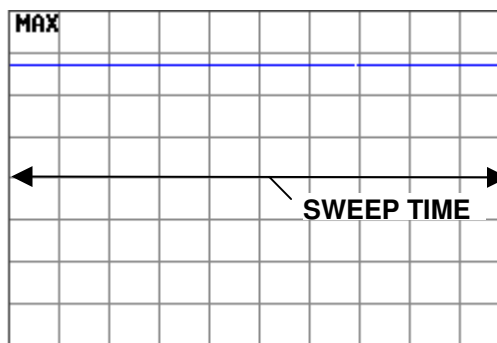

Center: 1GHz Time: 5ms/div

Switching over to the frequency domain

4. Press the **LAST SPAN** function key in the **SPAN** submenu.

The last span is displayed in the diagram area.

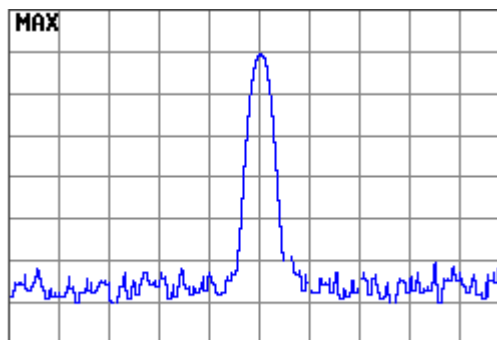

Center: 1GHz Span: 1MHz

6.2.1.2.4 ZOOM Functions

Use

If you want to increase or decrease the size of the screen window to analyze traces, you can zoom onto sections of the span or fill the whole screen with the current screen window.

Reducing the span

- Press the **ZOOM IN** function key in the **SPAN** submenu.

The span is reduced by a factor of two. The center frequency remains the same.

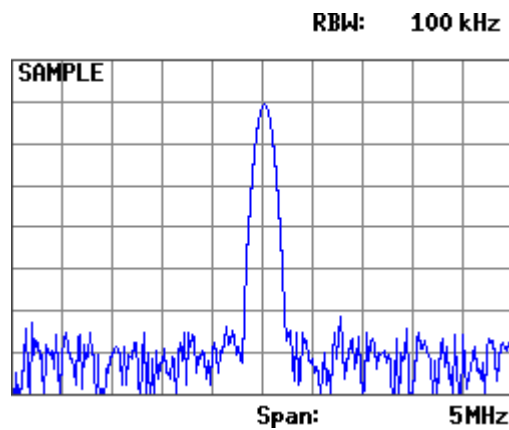

Increasing the span

- Press the **ZOOM OUT** function key in the **SPAN** submenu.

The span is increased by a factor of two. The center frequency remains the same. The center frequency will be adapted if the new display frequency range exceeds the maximum permissible start or stop frequency.

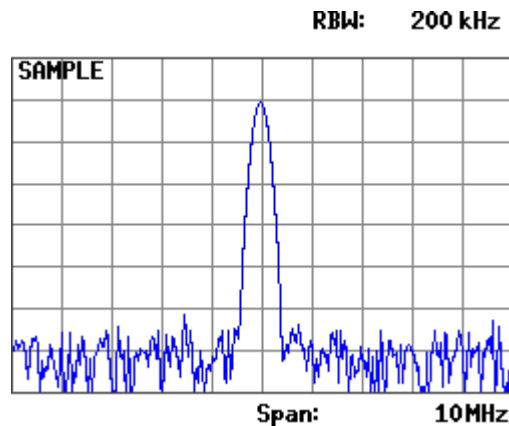

6.2.1.3 Entering the Start Frequency and the Stop Frequency

Use If you want to analyze a specific frequency range, you can enter a start frequency and a stop frequency. The frequency range is shown along the x axis of the diagram area.

Entering a start frequency

1. Press the **START** function key in the **FREQ/SPAN** menu.

An entry field containing the current setting is displayed in the top left-hand corner.

Start
0 Hz

2. Enter the new value (↗ 5-57).

The entry range for the start frequency is:

$0 \leq \text{Start} \leq 2.999999 \text{ GHz}$

Entering a stop frequency

3. Press the **STOP** function key in the **FREQ/SPAN** menu.

An entry field containing the current setting is displayed in the top left-hand corner.

Stop
3.000000000 GHz

4. Enter the new value (↗ 5-57).

The entry range for the stop frequency is:

$1 \text{ kHz} \leq \text{Stop} \leq 3 \text{ GHz}$

The new setting is saved and displayed in the diagram area. The grid lines associated with the frequency axis represent 1/10 of the current span.

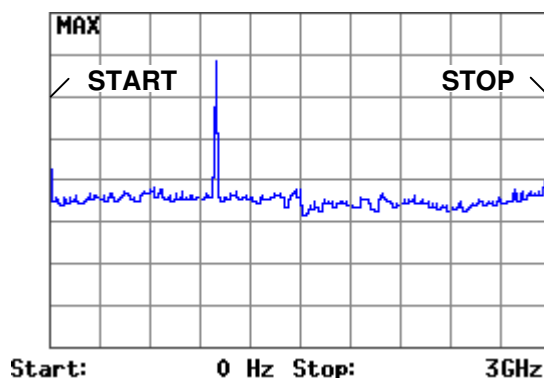

Note

The effect of pressing the **START** or the **STOP** function key is to switch the lettering of the frequency axis in the diagram area to the display showing the current start and stop frequencies.

6.2.1.4 Entering the Step Width of the Center Frequency

What the settings are for

Using the CF STEP SIZE submenu, you can set any step size of the rotary knob you want or have the R&S FS315 set a step size that is a function of the measurement parameters.



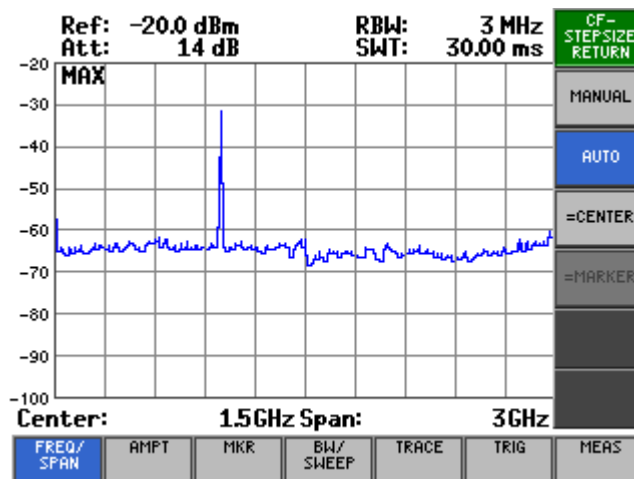

Selecting the CF STEP SIZE submenu

- Press the  function key in the  menu.

The submenu opens and the appropriate functions are assigned to the function keys [13].





Function key assignment

	Quitting the submenu	
	Setting the step size manually	(↗ 6-81)
	Setting the step size automatically	(↗ 6-81)
	Setting the step size to the center frequency	(↗ 6-81)
	Setting the step size to the marker frequency	(↗ 6-81)



Note

The  and  function keys are selection keys. In other words, only one setting can be activated at any one time. The function key in question is highlighted.

The AUTO function is the default setting.

The  function key is available only when marker 1 is turned on.

6.2.1.4.1 Setting the Step Size

Setting the step size manually

If you want to examine the frequency spectrum at certain intervals, you can enter the value of your choice for the step size of the rotary knob.

1. Press the **MANUAL** function key in the **CF-STEP SIZE** submenu.

An entry field containing the current setting is displayed in the top left-hand corner.

StepSize 1.50000000 GHz

2. Enter the new value (↗ 5-57).

The entry range for the step size is:

$$1 \text{ Hz} \leq \text{Step Size} \leq 2.999999 \text{ GHz}$$

Setting the step size automatically

If you want to change the center frequency using steps that are small compared with the span, select the automatic setting mode.

- Press the **AUTO** function key in the **CF-STEP SIZE** submenu.

The step size is set to a tenth of the current span.

Setting the step size to the center frequency

If you make the step size equal to the center frequency (or an integer multiple of the center frequency), it is easy to find harmonics which are multiples of the center frequency.

- Press the **=CENTER** function key in the **CF-STEP SIZE** submenu.

The step size is made equal to the current center frequency.

Setting the step size to the marker frequency

If you make the step size equal the marker frequency, you can search through the frequency spectrum and quickly jump back to the frequency at which you started.

- Press the **=MARKER** function key in the **CF-STEP SIZE** submenu.

The step size is made equal to the current marker frequency (↗ 6-101).

6.2.1.5 Activating Signal Tracking

Use

If the frequency of the signal being analyzed is continually varying, you can use this function to obtain a display that appears to be stationary. The power of signals of this kind can then be measured over long periods.

When signal tracking is selected, the center frequency of the R&S FS315 is continually set to the frequency of the signal with most power. This means that a signal whose frequency is changing slowly in comparison with the sweep time can be kept in the center of the screen. The capture range of the function is $\pm \text{span}/2$ referring to the center frequency. The spectrum analyzer's center frequency is adjusted after each sweep.

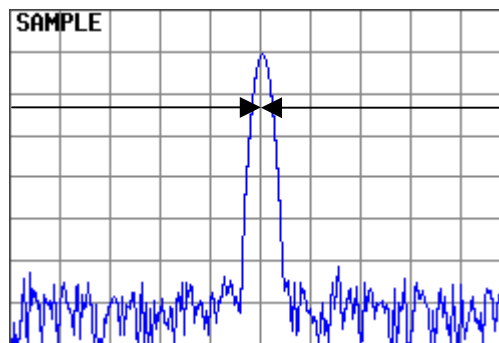

Activating signal tracking

- Press the **FREQ/SPAN** function key in the **SIGNAL TRACK** submenu.

The center frequency is constantly adjusted so that the signal peak is always in the middle of the screen. The latest center frequency to be set is displayed. The peak will continue to be tracked provided it remains within the span referring to the center frequency.

De-activating signal tracking

- Press the **FREQ/SPAN** function key in the **SIGNAL TRACK** submenu.

The center frequency ceases to be tracked and remains at its last value.

6.2.2 Setting the Level Axis and the RF Input (AMPT Menu)

What the settings are for

From the AMPT menu, you can define the y axis of the measurement diagram as the level axis. You can also specify the attenuation of the RF input.

Selecting the AMPT menu

- Select the **AMPT** menu with the **◀** or **▶** cursor key [6].

The menu name is highlighted and the appropriate functions are assigned to the function keys [13].

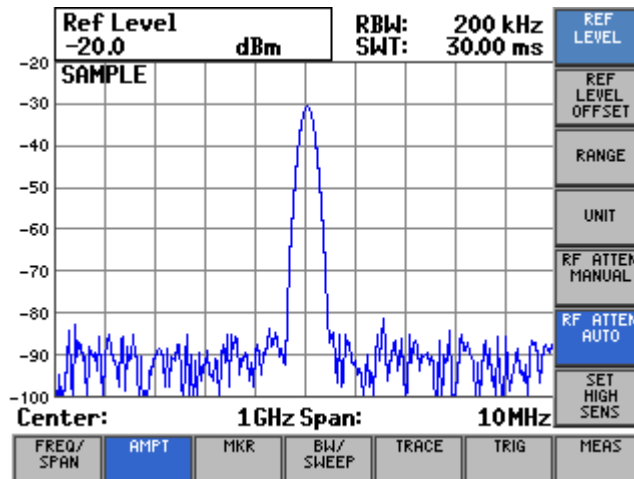

Function key assignment

REF LEVEL	Entering the reference level	(↗ 6-84)
REF LEVEL OFFSET	Entering a level offset	(↗ 6-85)
RANGE	Selecting the level display range	(↗ 6-86)
UNIT	Selecting the level display unit	(↗ 6-87)
RF ATTEN MANUAL	Setting the RF input attenuation manually	(↗ 6-89)
RF ATTEN AUTO	Setting the RF input attenuation automatically	(↗ 6-90)
SET HIGH SENS	Selecting the setting High Sensitivity	(↗ 6-92)

Note

The **RF ATTEN MANUAL** and **RF ATTEN AUTO** function keys are selection keys. In other words, only one setting can be activated at any one time. The function key in question is highlighted. The RF ATTEN AUTO function is the default setting.

The **UNIT** function key is only available for activated transducer factors if the unit of the antenna factors is dB.

6.2.2.1 Entering the Reference Level

Use The upper diagram limit is specified with the reference level.

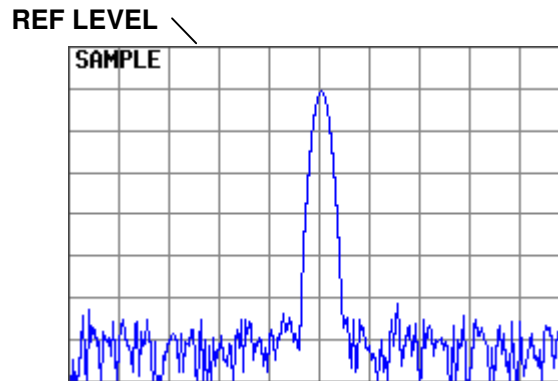

 **Note**

The currently activated unit is used as the unit for reference level entries (↗ 6-87). The default setting is “dBm”.

Entering the reference level

1. Press the  function key in the  menu.

An entry field containing the current setting is displayed in the top left-hand corner. The default setting is -20 dBm.

Ref Level	dBm
-20,0	

2. Enter a new value in 0.1 dB steps (↗ 5-57).

The entry range for the reference level is:

$$-110 \text{ [dBm]} \leq \text{Reference} \leq +36 \text{ [dBm]}$$

The new setting is saved and displayed in the diagram area. The reference level defines the upper limit of the diagram.

Ref: -20.0 dBm

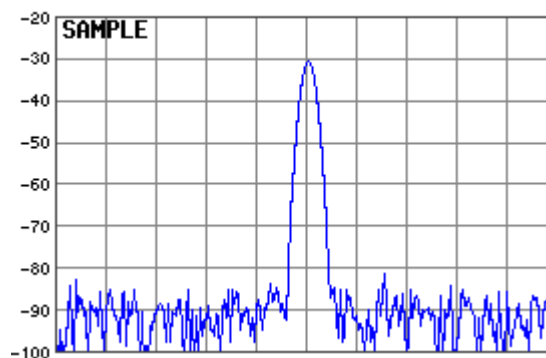

6.2.2.2 Entering a Level Offset

Use If you have connected external attenuators or amplifiers between the DUT and the RF input, you can enter a level offset to adjust the level display. The level offset is added to the reference level.

REF LEVEL + REF LEVEL OFFSET

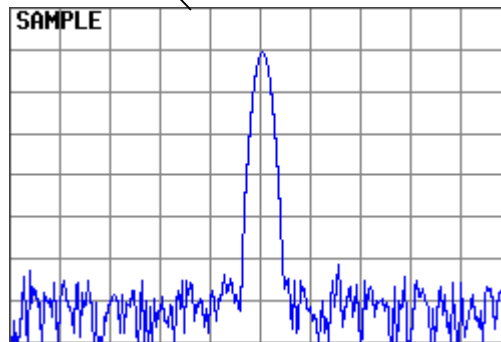

Entering a level offset

1. Press the **REF LEVEL OFFSET** function key in the **AMPT** menu.

An entry field containing the current setting is displayed in the top left-hand corner. The default setting is 0 dB.

Ref Lvl Offset
0.0 dB

2. Enter a new value in 0.1 dB steps (↵ 5-57).

The entry range for the level offset is:

$$-100 \text{ [dB]} \leq \text{Ref Lvl Offset} \leq +50 \text{ [dB]}$$

The new setting is saved and displayed in the diagram area. The text "Offs" is also displayed in the top left of the diagram.

The level offset is always entered in dB no matter what unit is used for the reference level. If the units mV or mW are used, the offset is automatically converted so that the reference level is displayed correctly:

$$\text{REF LEVEL}_{\text{Display}} = \text{REF LEVEL} + \text{REF LEVEL OFFSET}$$

e.g. $-20 \text{ dBm} + 40 \text{ dB} = 20 \text{ dBm}$

Offs Ref: 20.0 dBm

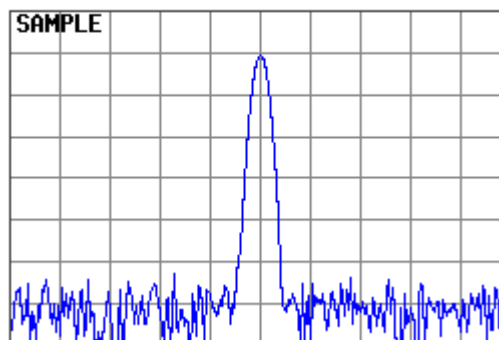

6.2.2.3 Selecting the Level Display Range

Use Use the level display range to define the “visible” level range and set the measurement diagram scale.

Levels can be displayed using either logarithmic or linear scales. The lettering of the grid lines is automatically adapted.

- **8 dB**
1 dB/div.
- **16 dB**
2 dB/div.
- **40 dB**
5 dB/div.
- **80 dB**
10 dB/div.
- **linear 0..100%**
12.5 %/div., linear scale, 100 % corresponds to the reference level, 0 % to 0 V or 0 W

Entering the level display range

1. Press the **RANGE** function key in the **AMPT** menu.

A selection field containing the available settings is displayed. The default setting is 80 dB.

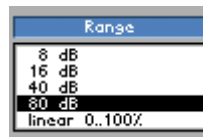

2. Select a level display range with **rotary knob** [11].
3. Press the **ENTER key** [5] to close the selection field.

The new setting is saved and displayed in inverse video in the diagram area. The level display range is referred to the reference level. This determines how the grid lines are lettered, for example, for REF LEVEL = -20 dBm and RANGE = 80 dB, the first grid line is at -20 dBm and the second at -30 dBm, and so on.

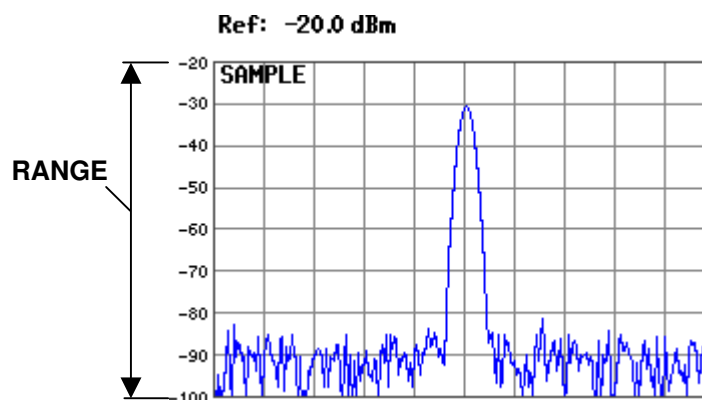

Note

The level display range uses the currently activated unit (↗ 6-87).

6.2.2.4 Selecting the Level Display Unit



Note

The **UNIT** function key is only available for activated transducer factors if the unit of the antenna factors is dB.

Use

To make it easier to analyze results, you can display levels in **dBm**, **dBmV**, **dB μ V**, **dB μ A**, **mV** and **mW**.

Selecting the unit for the level display

1. Press the **UNIT** function key in the **AMPT** menu.

A selection field containing the available settings is displayed. The default setting is dBm.

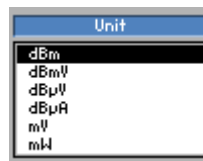

2. Select a unit for the level display with **rotary knob** [11].
3. Press the **ENTER** key [5] to close the selection field.
The new setting is saved and displayed in the diagram area.

How RANGE and UNIT are related

Log display/RANGE in dBx (The letter x is a wildcard character for the letters m, mV or μ V.)

If a dB display has been selected for RANGE (↵ 6-86) and a dBx display for UNIT, the vertical-scale unit is dB. The values indicated by the level markers and the relevant level entries are in dBx.

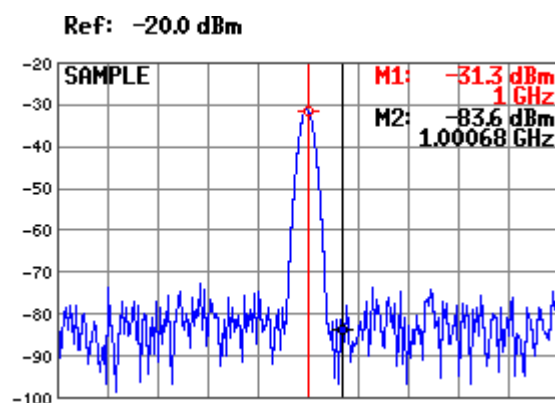

Log display/RANGE in xV, xA or xW (The letter x is a wildcard character for the letters m or μ .)

If a mV or mW has been selected for UNIT, only the reference level is displayed in the selected unit. There is no grid lettering. The values shown by the level markers and the relevant level entries are in the selected unit.

Ref: 22.4 mV

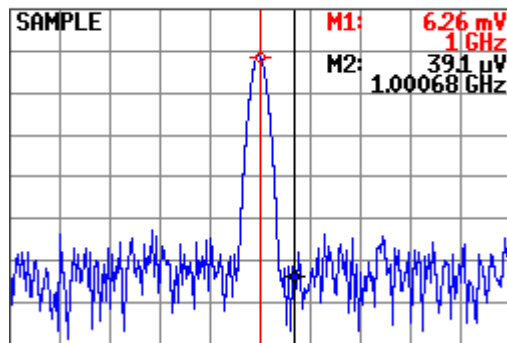

Linear display/RANGE in xV, xA or xW (The letter x is a wildcard character for the letters m or μ .)

If the linear scale is selected for RANGE, the scale lettering indicates percent, e.g. 0 %, 25 %, 50 %, 75 % and 100 %. The values indicated by the level markers and the relevant level entries are in the selected unit.

Ref: 22.4 mV

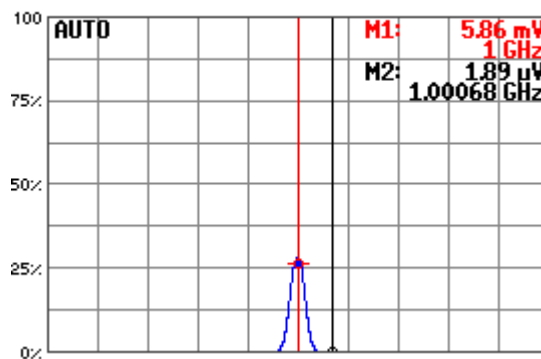

6.2.2.5 Setting the RF Input Attenuation Manually

Use

In the default setting, the input attenuation is coupled to the reference level. In most cases, this is the setting that will be used because it prevents the input stages from being overdriven and so, consequently, any incorrect measurements.

In exceptional cases, it may be necessary to adjust the input attenuation manually with input attenuations from **0** to **70 dB**.

Setting the input attenuation manually

1. Press the  function key in the  menu.

An entry field containing the current setting is displayed in the top left-hand corner. The default setting is 16 dB.

RF Atten Manual
14.0 dBm

2. Enter a new value in 2 dB steps (↗ 5-57).

The entry range for the input attenuation is:

$$0 \text{ [dB]} \leq \text{RF Atten Manual} \leq 70 \text{ [dB]}$$

The new setting is saved and the RF input is re-configured.



Note

If you enter an intermediate value (e.g. 3 dB) which the R&S FS315 cannot set, the next largest value will be set instead (4 dB).

6.2.2.6 Setting the RF Input Attenuation Automatically

Use

The input attenuation should be set automatically to prevent the R&S FS315's input mixer from being overloaded. There are three RF input modes you can choose from (coupling between reference level and input attenuation) to optimize measurements:

- **NORMAL**
Normal setting for measurements

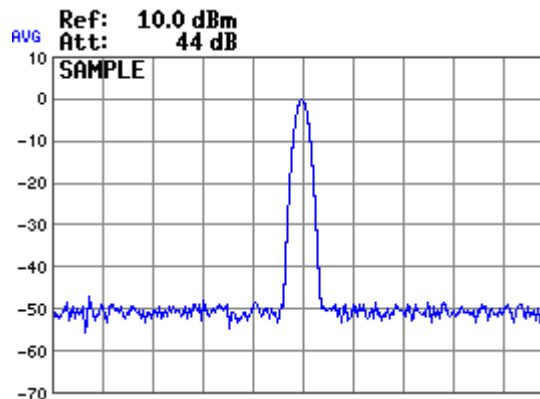

- **LOW NOISE**
Settings for measurements with low displayed average noise level of the analyzer

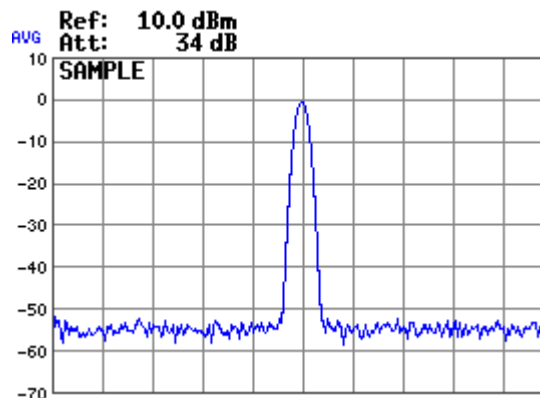

- **LOW DISTORTION**
Setting for measurements with low inherent distortion of the analyzer

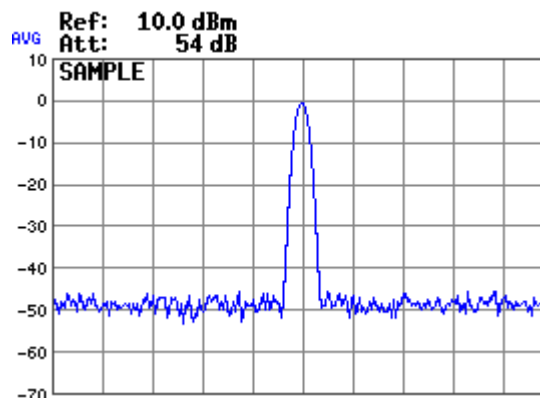

Activating the automatic input attenuation setting mode

1. Press the  function key in the  menu.

A selection field containing the available settings is displayed. The default setting is NORMAL.

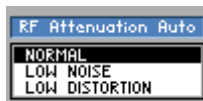

2. Using the **rotary knob** [11] select a criterion for autosetting the input attenuation.
3. Press the **ENTER key** [5] to close the selection field.
The new setting is saved and the RF input is configured automatically according to the setting.

6.2.2.7 Selecting the Setting High Sensitivity

Use

By setting SET HIGH SENS, you can change several settings in the device in order to increase the input and measurement sensitivity of the analyzer in comparison to the normal setting. This function is helpful when you want to measure weak antenna signals with the analyzer.

SET HIGH SENS influences the following settings in the R&S FS315:

- Sets the **reference level** (REF LEVEL, ↗ 6-84) to -10 dBm.
- Sets the **input attenuation** (RF ATTEN, ↗ 6-89) to 0 dB.
- Activates the **coupling** (RBW/SPAN LOW NOISE, ↗ 6-123).
If RES BW was set to MANUAL, the analyzer switches to AUTO.

Selecting the Setting High Sensitivity

- Press the  function key in the  menu.

The setting RBW/SPAN LOW NOISE is indicated by the letters LN next to the RBW display.

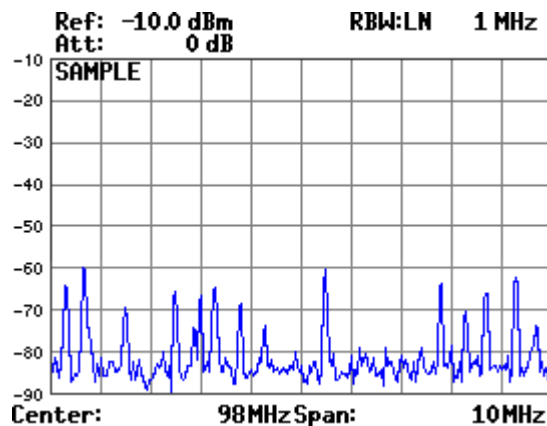

Note

You can switch the input attenuation of the analyzer to 0 dB by means of SET HIGH SENS. To ensure that the R&S FS315 is not overdriven, the level at the analyzer input must not exceed the reference level that has been set minus 15 dB. (↗ 6-84).

6.2.3 Signal Analysis using Marker Functions (MKR Menu)

What the settings are for

Using the MKR menu, you can position markers on any point on the trace to read off any levels or level differences of interest. The measured values indicated by the markers (marker values) are displayed in the parameter field (↗ 5-51).

A scrollable display line can also be shown on-screen.





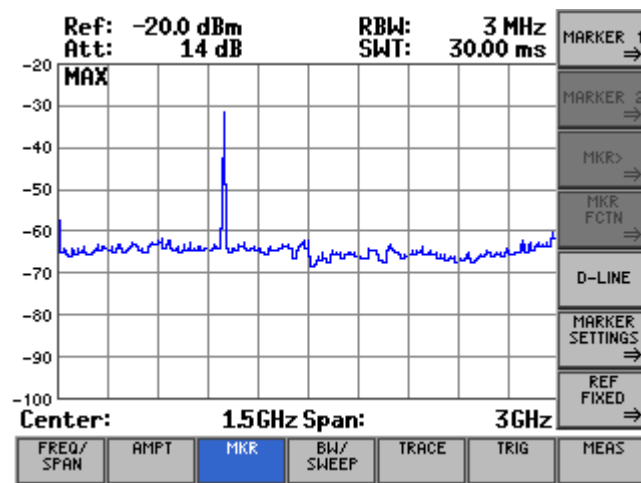

Selecting the MKR menu

- Select the  menu with the ◀ or ▶ cursor key [6].

The menu name is highlighted and the appropriate functions are assigned to the function keys [13].



Function key assignment



	Open submenu: Activate marker 1	(↗ 6-94)
	Open submenu: Activate marker 2	(↗ 6-98)
	Open submenu: Accepting marker values as settings	(↗ 6-101)
	Open submenu: Marker measurement functions	(↗ 6-105)
	Show display line	(↗ 6-110)
	Open submenu: Search criterion of functions NEXT PEAK LEFT/RIGHT	(↗ 6-111)
	Open submenu: Reference points for level-difference measurements	(↗ 6-114)



Note

The  and  function keys are selection keys.

The  function key is available only when marker 1 is turned on.

The ,  and  function keys are available only when marker 1 is turned on.

6.2.3.1 Activating Marker 1

What the settings are for

From the MARKER 1 submenu, you can activate a marker and position it on the trace. All the current level and frequency values (marker values) are displayed.

The frequency indicated by the marker can be measured more accurately with the FREQ COUNT function.

Selecting the MARKER 1 submenu

- Press the **MARKER 1** function key in the **MKR** menu.

If marker 1 is not yet activated, the marker is set to the strongest signal (peak). An entry field containing the current marker frequency appears in the top left-hand corner. The submenu is opened and the respective functions are assigned to the function keys [13].

If the marker is already activated, the entry field opens without the position of the marker being changed.

Function key assignment

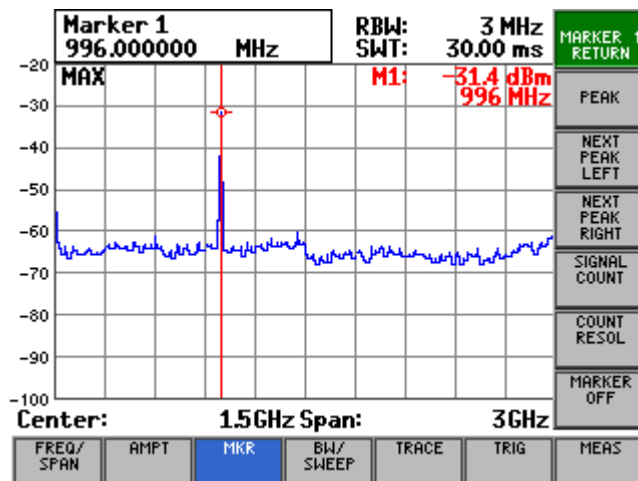

MARKER 1 RETURN	Quitting the submenu	
PEAK	Activate marker 1 and place it on the trace maximum	(↗ 6-95)
NEXT PEAK LEFT	Place marker 1 on the next peak to the left	(↗ 6-95)
NEXT PEAK RIGHT	Place marker 1 on the next peak to the right	(↗ 6-95)
SIGNAL COUNT	Measure the signal frequency: Start the measurement	(↗ 6-97)
COUNT RESOL	Measure the signal frequency: Set the resolution	(↗ 6-97)
MARKER OFF	De-activate marker 1	(↗ 6-95)

Note The **SIGNAL COUNT** and **COUNT RESOL** function keys are available only when marker 1 has been activated.

6.2.3.1.1 Reading off Measured Values with Marker 1

Use You can position marker 1 on the trace to read off specific levels and frequencies (marker values).

Activating marker 1 and placing it on the trace maximum

1. Press the **PEAK** function key in the **MARKER 1** submenu.

Marker 1 is activated and placed on the current trace maximum. M1 marker values are displayed in the parameter field.

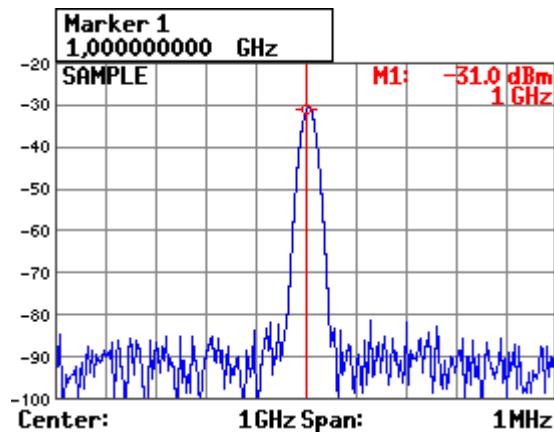

Placing marker 1 on the next trace maximum

2. Press the **NEXT PEAK RIGHT** or **NEXT PEAK LEFT** function key in the **MARKER 1** submenu.

Marker 1 is positioned on the next trace maximum to the right (or left). The new M1 marker values are displayed in the parameter field.

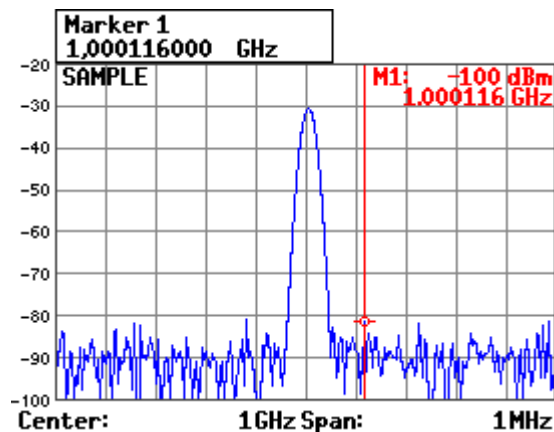

Note

The search criterion of functions NEXT PEAK LEFT/RIGHT can be changed by using the function key **PEAK EXCURS** (↗ 6-112).

Moving marker 1 to any position

- Enter a new value for the marker frequency using the numerical keys [12], rotary knob [11] or cursor keys [7]. The permissible entry range is:

$$f_{\text{Center}} - \text{Span}/2 \leq f_{\text{Marker}} \leq f_{\text{Center}} + \text{Span}/2$$

- where f_{Marker} - Marker frequency
 f_{Center} - current center frequency (↗ 6-73)
 Span - current Span (↗ 6-75)

The current M1 marker values are displayed in the parameter field.

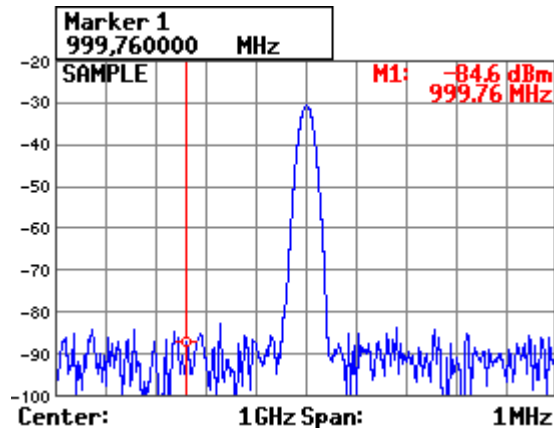

De-activating marker 1

- Press the **MARKER OFF** function key in the **MARKER 1** submenu.

Marker 1 (and marker 2, if activated) disappears from the diagram area and the M1 (M2) marker values are blanked out.

Note

The marker can only be moved if the entry window is open. If you closed the entry window with ESC/CANCEL key [4], you must briefly leave the Marker 1 menu before you can open the entry window again. Then press the **MKR**

function key in the **MARKER 1** menu to open the entry window again.

If the center frequency setting is such that the set marker is outside the frequency span, the last value is frozen as the reference.

6.2.3.1.2 Frequency Measurements using the Frequency Counter

Use

The normal marker indicates the frequency represented by the pixel on which it is placed. The measurement uncertainty is relatively large because the number of pixels is limited to 250.

When a measurement is made with the frequency counter, the sweep is stopped at the frequency indicated by marker 1, the frequency is counted using the required resolution (**10 Hz**, **1 Hz**) and then the sweep is restarted. There must be a periodic signal at the marker position if the measurement is to be successful.

Setting the resolution

1. Position marker 1 on the trace (↗ 6-94).

The current M1 marker values are displayed in the parameter field.

2. Press the **COUNT RESOL** function key in the **MARKER 1** submenu.

A selection field containing the available settings is displayed. The default setting is 1 Hz.



3. Select a resolution for the internal frequency counter with **rotary knob** [11], e.g. 10 Hz.
4. Press the **ENTER** key [5] to close the selection field.

The new setting is saved.

Measuring the signal frequency

5. Press the **SIGNAL COUNT** function key in the **MARKER 1** submenu.

The frequency is counted with the internal counter. The result (C1) is displayed in the parameter field instead of the marker frequency (M1).

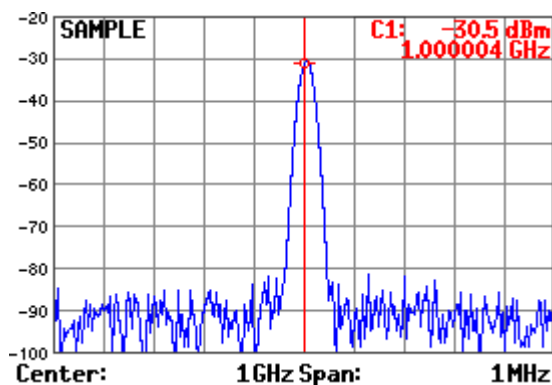

De-activating the measurement

- Press the **SIGNAL COUNT** function key in the **MARKER 1** submenu.

The internal counter is turned off. The current M1 marker values are again displayed in the parameter field.



Note

The absolute accuracy of the frequency measurement depends on the frequency stability of the reference-oscillator. When the internal reference is used, the accuracy is given according to the values specified in the data sheet. (↗ 0-12).

6.2.3.2 Activating Marker 2

What the settings are for

From the MARKER 2 submenu, you can activate a second marker and position it on the trace. Marker 2 can be used either as a normal marker (NORM) or as a delta marker (DELTA). The delta marker function expands the R&S FS315's analysis capability and can be used as a basis for a variety of measurement techniques (↗ 6-143).

Marker 2 can only be activated if marker 1 has been activated.

Selecting the MARKER 2 submenu

- Press the **MARKER 2** function key in the **MKR** menu.

If marker 2 is not yet activated, the marker is set to the strongest signal (peak). An entry field containing the current marker frequency appears in the top left-hand corner. The submenu is opened and the respective functions are assigned to the function keys [13].

If the marker is already activated, the entry field opens without the position of the marker being changed.

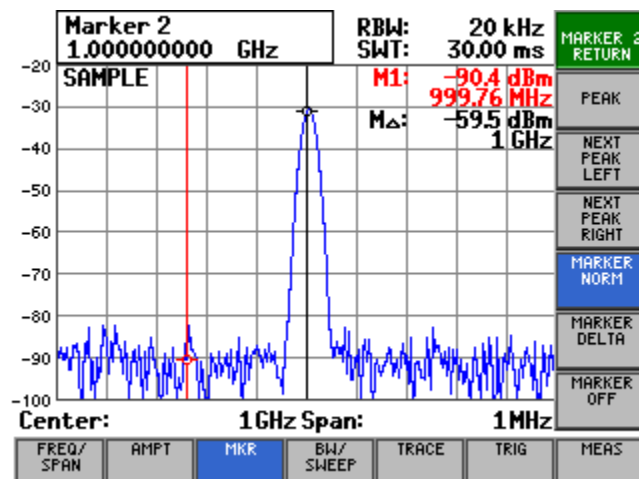

Function key assignment

MARKER 2 RETURN	Quitting the submenu	
PEAK	Activate marker 2 and position it on the trace maximum	(↗ 6-99)
NEXT PEAK LEFT	Place marker 2 on the next peak to the left	(↗ 6-99)
NEXT PEAK RIGHT	Place marker 2 on the next peak to the right	(↗ 6-99)
MARKER NORM	Set marker 2 as a normal marker (NORM)	(↗ 6-100)
MARKER DELTA	Set marker 2 as a delta marker (DELTA)	(↗ 6-100)
MARKER OFF	De-activate marker 2	(↗ 6-99)

Note

The **MARKER NORM** and **MARKER DELTA** function keys are selection keys. In other words, only one setting can be activated at any one time. The function key in question is highlighted. The MARKER NORM function is the default setting.

6.2.3.2.1 Reading off Measured Values with Marker 2

Use

To read off specific levels, you can activate marker 2 as a normal marker (in addition to marker 1) and position it on the trace. The current level and frequency can be displayed in this way (M2 marker values).

Activating marker 2 as a normal marker (NORM)

1. Press the **MARKER NORM** function key in the **MARKER 2** submenu.

Marker 2 is defined as a normal marker. The M2 absolute marker values are displayed in the parameter field.

2. Position marker 2 on the trace (↗ 6-95).

The current M2 marker values are displayed in the parameter field.

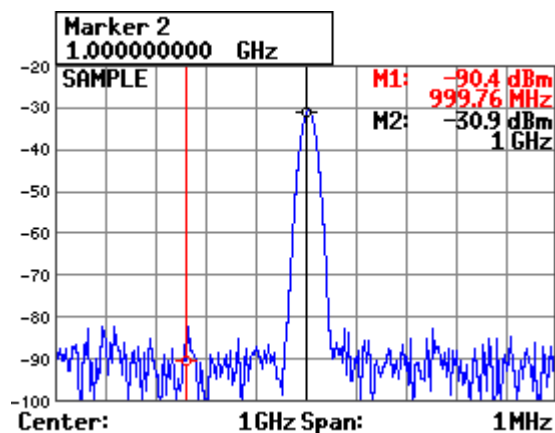

De-activating marker 2

- Press the **MARKER OFF** function key in the **MARKER 2** submenu.

Marker 2 disappears from the diagram area and the M2 marker values are blanked out.

6.2.3.2.2 Reading off Level Differences

Use

You can define marker 2 as a delta marker to read off level differences from the trace. The level difference between marker 2 and a reference point is displayed. Marker 1 (↗ 6-94) or reference values that have been set manually (↗ 6-114) can be used as reference points.

Defining marker 2 as a delta marker (DELTA)

1. Press the **MARKER DELTA** function key in the **MARKER 2** submenu.

Marker 2 is defined as a delta marker. The relative delta marker values (M), which represent the level difference between marker 2 and a reference point, e. g. marker 1, are displayed in the parameter field.

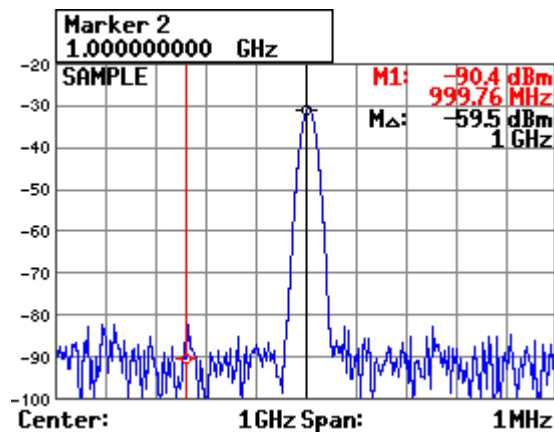

De-activating marker 2

2. Press the **MARKER OFF** function key in the **MARKER 2** submenu.

Marker 2 disappears from the diagram area and the M2 marker values are blanked out.

6.2.3.3 Accepting Marker Values as Settings

What the settings are for

From the MKR> submenu, you can accept the marker values of the active marker as settings for level, frequency or frequency steps.

The step size used to enter the center frequency with the help of the rotary knob can also be the marker frequency.



Note

The function key is only available when the markers are activated.

Selecting the MKR> submenu

- Press the function key in the menu.

The submenu is opened and the appropriate functions are assigned to the function keys [13].

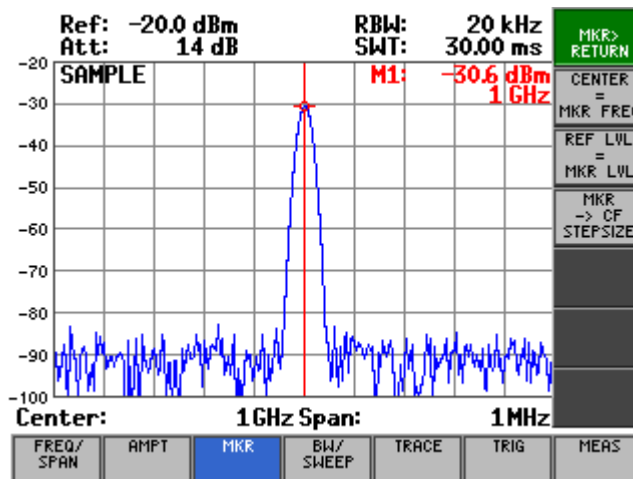

Function key assignment



Quitting the submenu



Set the center frequency (CENTER) to the marker frequency
Moving the trace in the diagram area (x axis) (↗ 6-102)



Set the reference level (REF LEVEL) to the marker level
Moving the trace in the diagram area (y axis) (↗ 6-102)



Set the step size for entering the center frequency to the marker frequency (↗ 6-104)



Note

In the time-domain mode (ZERO SPAN), the function key is not available.

6.2.3.3.1 Moving Trace Sections in the Measurement Diagram

Use

If you want to analyze a section of the trace more closely, you can change its location within the measurement diagram using the active marker. The marker frequency becomes the center frequency and the marker level becomes the upper diagram boundary.

You can then analyze the trace section using a smaller span (↗ 6-75).

Positioning markers on the trace

1. Activate the markers (↗ 6-94, 6-98).

2. Press the  or  function key in the  menu.

The selected marker is activated. All further marker settings are for the active marker, e. g. marker 1.

3. Position the active marker on the trace (↗ 6-95, 6-99).

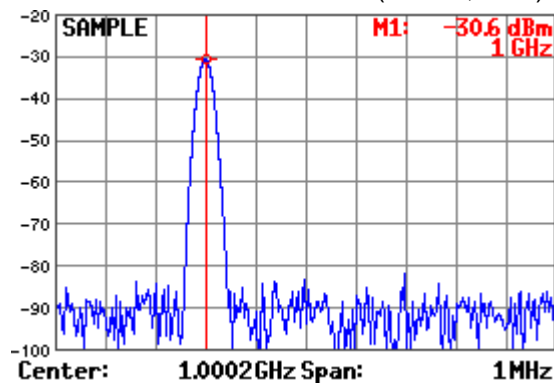

Setting the center frequency to the marker frequency

4. Press the  function key in the  menu.

The marker frequency is made the current center frequency (↗ 6-73). The trace is shifted horizontally to bring marker 1 into the center of the measurement diagram.

The span remains unchanged provided the limits of 9 kHz or 3 GHz are not reached. Otherwise the span is reduced symmetrically about the center frequency. The lower limit for the span is 1 kHz.

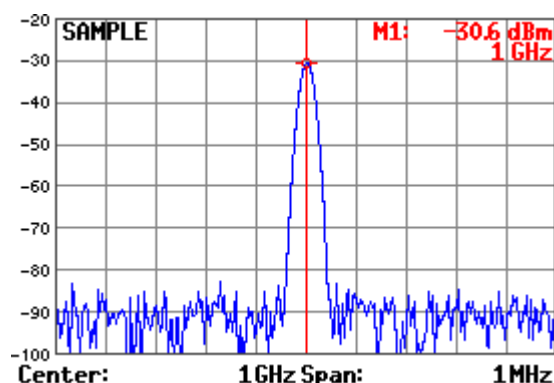

Note

In the time-domain mode (ZERO SPAN), the  function key is not available.

**Setting the
reference level to
the marker level**

5. Press the  function key in the  submenu.

The current marker level is set as the reference level (↗ 6-84). The trace is shifted vertically until the marker level forms the upper limit of the measurement diagram. The minimum value that can be set is -110 dBm.

Ref: -30.6 dBm

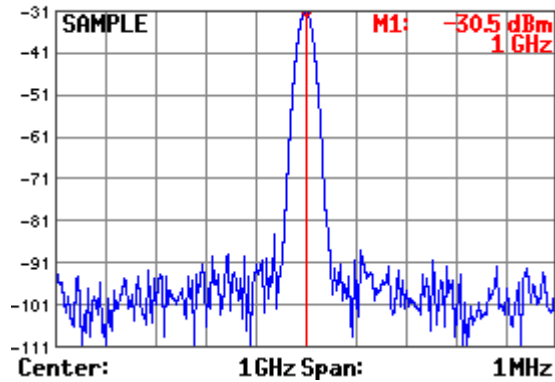

6.2.3.3.2 Setting the Step Size to the Marker Frequency

Use If you set the step size to the marker frequency, you will find that you can quickly jump back to the start frequency when you are stepping through the frequency spectrum with the help of the rotary knob.

Positioning markers on the trace

1. Turn on the markers (↗ 6-94, 6-98).

2. Press the **MARKER 1** or **MARKER 2** function key in the **MKR** menu.

The selected marker is activated. All further marker settings are for the active marker, e.g. marker 1.

3. Position the activated marker on the trace (↗ 6-95, 6-99).

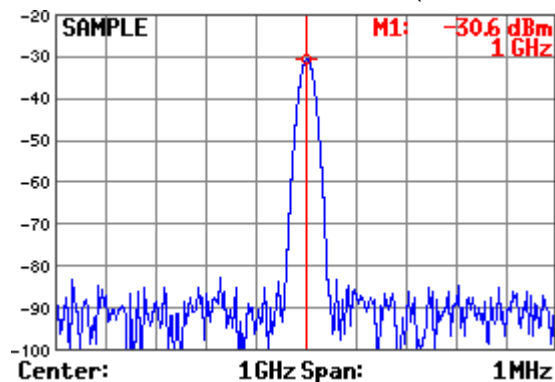

4. Press the **=MARKER** function key in the **MKR → CF STEPSIZE** submenu.

The step size is set to the current marker frequency.



Note

“Setting the step size to the marker frequency” has the same function as the setting “step size for entering the center frequency” (↗ 6-80).

6.2.3.4 Marker Measurement Functions

What the settings are for From the MKR FCTN submenu, using the markers, you can select certain spectral components of the input signal to measure the noise power density and the signal bandwidth.



Note

The  function key is available only when the markers are turned on.

Selecting the submenu MKR FCTN

- Press the  function key in the  menu.

The submenu is opened and the appropriate functions are assigned to the function keys [13].

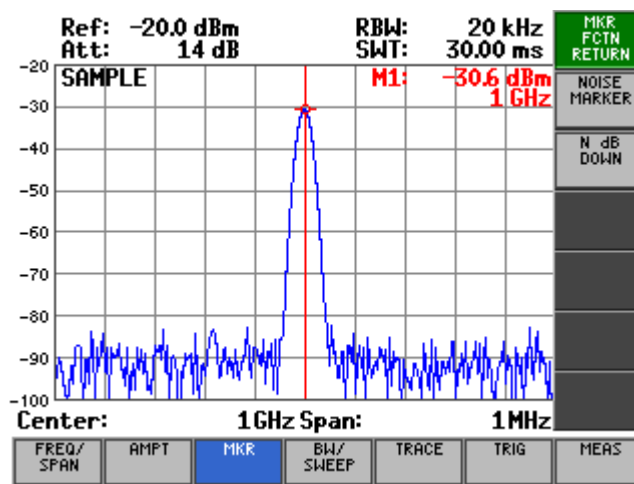

Function key assignment



Quitting the submenu



Measuring the noise power density (↗ 6-106)



Measuring the signal bandwidth (↗ 6-108)

6.2.3.4.1 Measuring the Noise Power Density

Use The R&S FS315 allows you to measure the noise power density at the active marker position.

Measuring noise power density

1. Turn on the markers (↗ 6-94, 6-98).
2. Position the activated marker (↗ 6-95, 6-99) as desired.

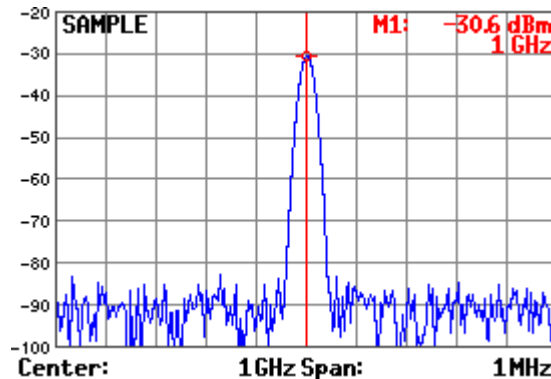

3. Press the **NOISE MARKER** function key in the **MKR FCTN** submenu.

The noise power density measurement is started at the frequency indicated by a marker. If marker 1 is the only marker that has been turned on, the measurement is made at its position. If marker 2 has also been turned on, the measurement is made at its position.

Two points in the frequency domain (one to the right and one to left of the marker) are used in the calculation to obtain a stable measurement result. All points in the time domain are used to calculate the noise power density. The noise power density is displayed in the marker field of the appropriate marker.

Measurement display

If only one marker is activated, the noise power density is displayed as an absolute value in the selected unit:

- **dBm/Hz, W/Hz** for powers
- **dB μ V/ $\sqrt{\text{Hz}}$, mV/ $\sqrt{\text{Hz}}$** for voltages

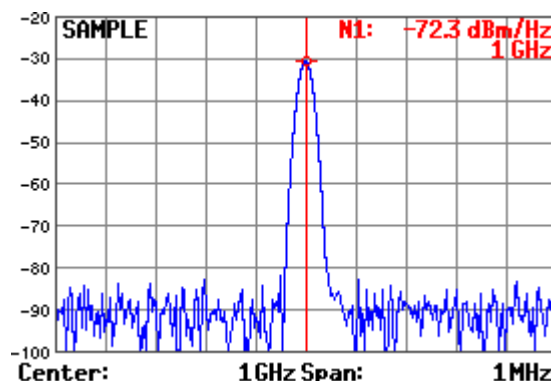

If marker 2 is activated as a delta marker, the noise power density is displayed relative to marker 1 in **dBc/Hz**.

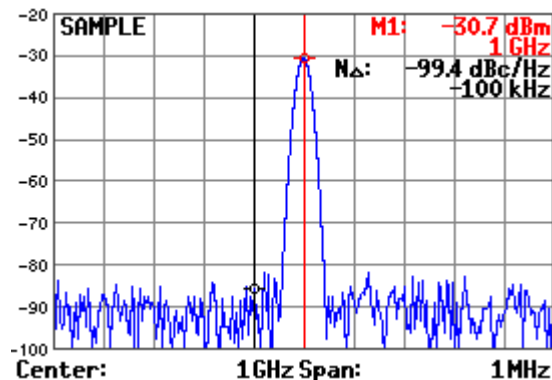

Additional measurement settings

The following additional settings must be made to ensure that the noise power density measurement returns correct values:

- **Detector**
Sample or RMS (↗ 6-129)
- **Video bandwidth:**
≤ 0.1 x resolution bandwidth for sample detector
≥ 3 x resolution bandwidth for RMS detector
- **Trace display mode**
With the sample detector, the trace can also be displayed in Trace Average mode in order to stabilize the measurements. If the RMS detector is used, trace averaging should not be used. Instead, the sweep time can be increased to provide stable measurement results.

The R&S FS315 uses the following correction factors to determine the noise power density from the marker level:

- **General**
Since the noise power is displayed referred to 1 Hz bandwidth, the bandwidth correction value is subtracted from the marker level. This correction value is $10 \times \lg(1\text{Hz}/\text{BW}_{\text{noise}})$, where BW_{noise} is the noise or power bandwidth of the set resolution filter (RBW).
- **Sample detector**
2.5 dB are added to the marker level as a result of averaging by the video filter, trace averaging and logarithmic scale. This is the difference between the displayed average value and rms value of white noise.
- **RMS detector**
Apart from bandwidth correction, no other correction values are required for the RMS detector as the RMS detector already indicates the power in every pixel of the trace.

De-activating the measurement

- Press the **NOISE MARKER** function key in the **MKR FCTN** submenu.

The noise power measurement is terminated. The marker used for the measurement reverts to being a normal marker. Marker values are again displayed in the parameter field.

6.2.3.4.2 Measuring the Filter or Signal Bandwidth

Use

If you want to measure the bandwidth of a certain signal spectrum shown in the measurement diagram, you can do this with the N dB DOWN function. Two lines one of which is n dB down on the active reference marker are displayed on the screen [14]. The difference between the measured frequencies is displayed on the screen as the bandwidth.

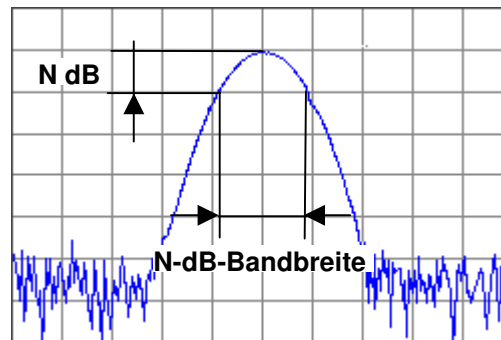

Selecting the signal spectrum

1. Position marker 1 on the trace maximum which is to form the reference for the bandwidth measurement (➔ 6-94).

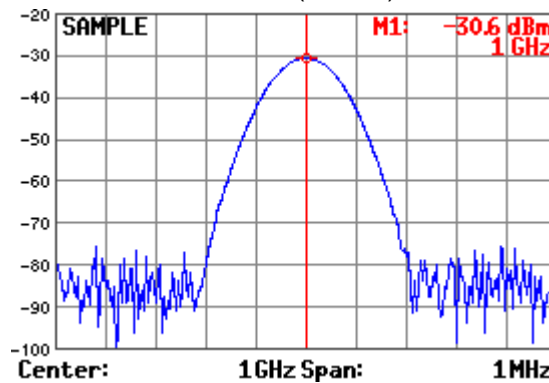

Measuring the signal bandwidth

2. Press the **N dB DOWN** function key in the **MKR FCTN** submenu.

An entry field containing the current attenuation setting of N dB is displayed in the top left-hand corner. The default setting is 3 dB.

N dB Down	dB
3	

3. Enter a new value (➔ 5-57).

The entry range for the attenuation N is:

$$0 \leq \text{down} \leq 100 \text{ dB}$$

The temporary markers T1 and T2 which are positioned to the right and left of marker 1 on the trace are activated. The levels at markers T1 and T2 are N dB less than the level at marker 1. The frequency difference between the markers T1 and T2 (N dB bandwidth) is displayed in the parameter field instead of the M2 marker values.

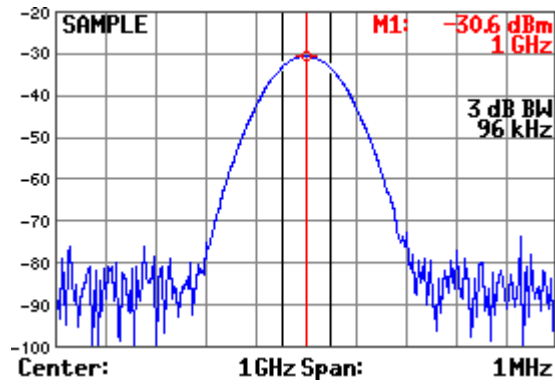

Terminating the measurement

- Press the **N dB DOWN** function key in the **MKR FCTN** submenu.

The signal or filter bandwidth measurement is terminated and the temporary markers T1 and T2 disappear from the screen.

6.2.3.5 Activating a Display Line

Use If you want to observe whether a signal exceeds or falls below a certain level you can activate a horizontal display line in the measurement diagram and adjust its position.

Activating the display line

1. Press the **D-LINE** function key in the **MKR** menu.

The display line appears and an entry field containing the current setting for position is displayed in the top left-hand corner. The default setting is 50 %.

D-Line	
50.00	%

Moving the display line

2. Enter a new value (↗ 5-57).

The entry range for the position is:

$$0\% \leq \text{D-Line} \leq 100\%$$

The current level is displayed on the left above the display line.

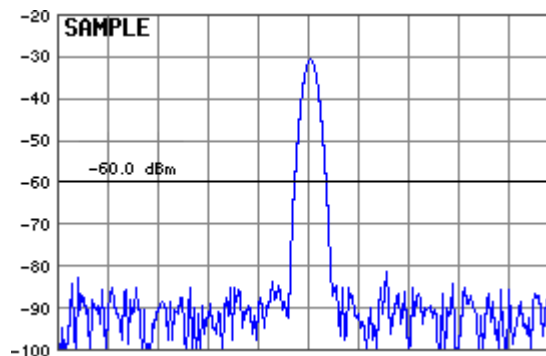

De-activating the display line

3. Press the **D-LINE** function key again in the **MKR** menu.

The display line disappears from the diagram area.

6.2.3.6 Setting the Search Criterion of Functions NEXT PEAK LEFT/RIGHT

What the settings are for

From the MARKER SETTINGS submenu, you can set the search criterion of functions NEXT PEAK LEFT/RIGHT. The PEAK EXCURSION function key enables – for level measurements – the entry of a minimum level value by which a signal must fall so that it will be identified as a maximum by the NEXT PEAK LEFT and NEXT NEXT PEAK RIGHT search functions.

Selecting the MARKER SETTINGS submenu

- Press the  function key in the  menu.

The submenu is opened and the appropriate functions are assigned to the function keys [13].

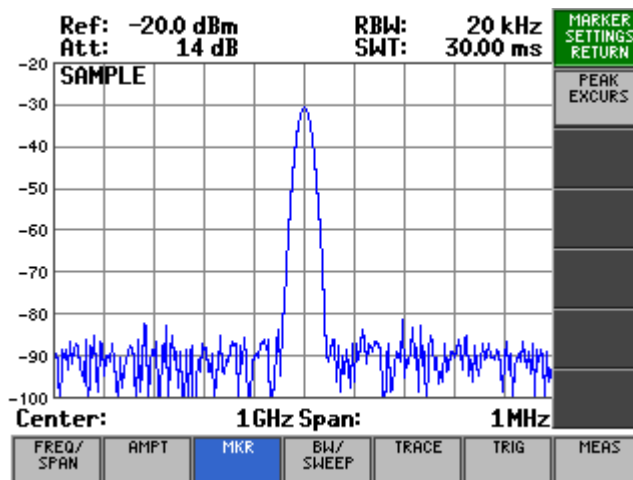

Function key assignment



Quitting the submenu



Entering the peak excursion

(↗ 6-112)

6.2.3.6.1 Entering the Peak Excursion

Use

If NEXT PEAK LEFT or NEXT PEAK RIGHT is selected, these functions search for the next relative maximum left or right of the current marker position irrespective of the current signal amplitude. When the signal level decreases for a definite amount, the peak excursion, to either side of the maximum a relative maximum is given.

Entering the peak excursion

1. Press the **PEAK EXCURS** function key in the **MARKER SETTINGS** submenu.

An entry field containing the current setting is displayed in the top left-hand corner. The default setting is 6 dB.

Peak Excursion
6 dB

2. Enter a new value in 0.1 dB steps (↗ 5-57).

The entry range for the reference-point level is:

$$0 \leq \text{Peak Excursion} \leq 80 \text{ dB}$$

The new setting is saved and it is the current search criterion when you use the functions NEXT PEAK LEFT/RIGHT (↗ 6-95).

Examples of level measurement with different settings of PEAK EXCURSION

The following example illustrates the effect of different settings of the PEAK EXCURSION.

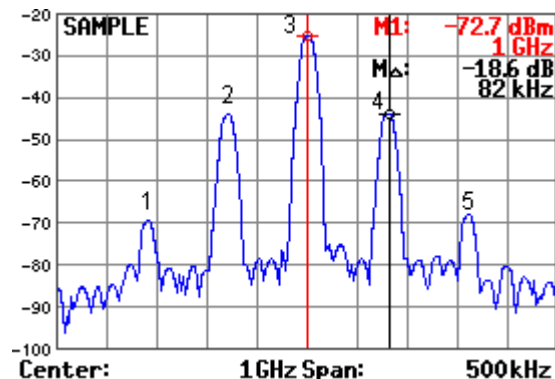

The following table lists the signals as indicated by numbers in the measuring diagram above, as well as the minimum of the amplitude decrease to both sides of the signal:

Signal #	Min. amplitude decrease to both sides of the signal
1	10 dB
2	35 dB
3	48 dB
4	35 dB
5	10 dB

**50 dB
peak excursion**

With this setting, NEXT PEAK LEFT and NEXT PEAK RIGHT will not find any signal, as the signal level does not decrease by more than 48 dB to either side of any signal.

Order of signals detected:

PEAK: signal 3
NEXT PEAK LEFT: signal 3 (no further signal detected)
NEXT PEAK RIGHT: signal 3 (no further signal detected)

**30 dB
peak excursion**

With this setting, NEXT PEAK LEFT and NEXT PEAK RIGHT will also detect signals 2 and 4, as the signal level decreases at least by 35 dB to either side of this signal, which is now greater than the peak excursion.

Order of signals detected:

PEAK: signal 3
NEXT PEAK LEFT: signal 2
NEXT PEAK LEFT: signal 2 (no further signal detected)
NEXT PEAK RIGHT: signal 3
NEXT PEAK RIGHT: signal 4
NEXT PEAK RIGHT: signal 4 (no further signal detected)

**6 dB
peak excursion**

With this setting, all signals will be detected with NEXT PEAK RIGHT or NEXT PEAK LEFT.

Order of signals detected:

PEAK: signal 3
NEXT PEAK LEFT: signal 2
NEXT PEAK LEFT: signal 1
NEXT PEAK LEFT: signal 1 (no further signal detected)
NEXT PEAK RIGHT: signal 2
NEXT PEAK RIGHT: signal 3
NEXT PEAK RIGHT: signal 4
NEXT PEAK RIGHT: signal 5
NEXT PEAK RIGHT: signal 5 (no further signal detected)

6.2.3.7 Setting Reference Points for Level-Difference Measurements

What the settings are for

From the REF FIXED submenu, you can define any reference point within the R&S FS315's measurement range. You can use this point as a fixed reference for level-difference measurements using the delta marker (↗ 6-100).





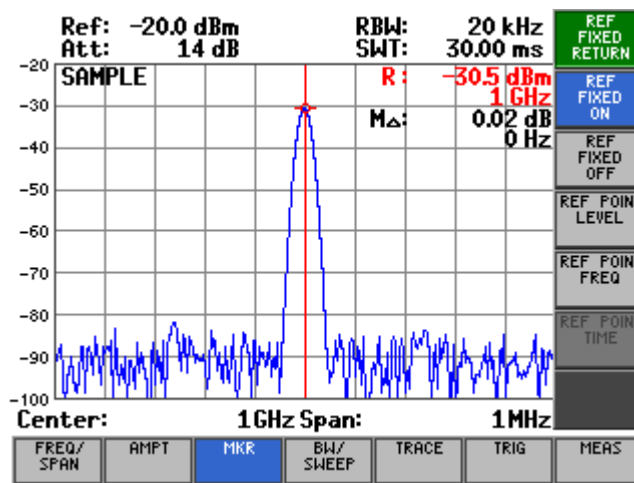

Selecting the REF FIXED submenu

- Press the  function key in the  menu.



The reference marker and delta marker (marker 2) are placed on the strongest signal (peak). The submenu is opened and the appropriate functions are assigned to the function keys [13].





Function key assignment

	Quitting the submenu	
	Activate the reference marker	(↗ 6-115)
	Deactivate the reference marker	(↗ 6-115)
	Enter the level for the reference marker	(↗ 6-115)
	Enter the reference point frequency	(↗ 6-115)
	Enter the reference point time	(↗ 6-115)

Note

The  and  function keys are selection keys. In other words, only one setting can be activated at any one time. The function key in question is highlighted.

The  function key is available only in the frequency domain (SPAN > 0). The  function key is available only in the time domain (ZERO SPAN).

6.2.3.7.1 Manual Entry of Reference Points

Use

There are two methods you can use to find level differences on the trace. The first method is to define a reference point on the trace using marker 1, whereby the entered level values must be within a specific range (↗ 6-94).

The second possibility is to use a reference marker which can be placed at any position, even outside the measurement diagram.

Marker 1 is replaced by the reference marker. The reference values R appear in the measurement diagram. Marker M2 indicates the level difference referred to the reference point.

Entering reference point levels

1. Press the  function key in the  submenu.

An entry field containing the current setting (frozen marker level) is displayed in the top left-hand corner.

Ref point level -54.1 dBm

2. Enter a new value in 0.1 dB steps (↗ 5-57).

The entry range for the reference-point level is:

$$-200 \text{ [dBm]} \leq \text{Ref point level} \leq +200 \text{ [dBm]}$$

The new setting is saved and displayed in the diagram area. The value is not displayed if it is outside the diagram area.

Entering a reference point frequency

3a) Frequency-domain display mode (SPAN > 0, ↗ 6-72):

- Press the  function key in the  submenu.

An entry field containing the current setting (frozen marker frequency) is displayed in the top left-hand corner.

Ref point freq
999.900000 MHz

- Enter a new value (↗ 5-57).

The entry range for the reference point frequency is:

$$0 \leq \text{Ref point freq} \leq 3 \text{ GHz}$$

The new setting is saved and displayed in the diagram area. If the value is outside the diagram area, a small blue arrow pointing toward the marker appears in the bottom half of the measurement diagram.

The level and the frequency at the reference point form the fixed reference point for level-difference measurements with the delta marker in the frequency domain (↗ 6-100).

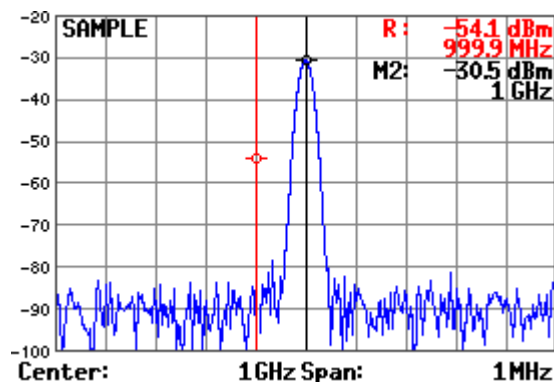

Entering a reference point time

3b) Time-domain display mode (ZERO SPAN, ↗ 6-77):

- Press the  function key in the  submenu.

An entry field containing the current setting (frozen marker time) is displayed in the top left-hand corner.

Ref point time
10 ms

- Enter a new value (↗ 5-57).

The entry range for the reference-point time is:

$$0 \text{ s} \leq \text{Ref point time} \leq t_{\text{SWEEP}}$$

where t_{SWEEP} - current SWEEP time (↗ 6-126)

The new setting is saved and displayed in the diagram area. If the value is outside the diagram area, it is not displayed.

The reference point level and time form a fixed reference point for level difference measurements with the delta marker in the time domain (↗ 6-100).

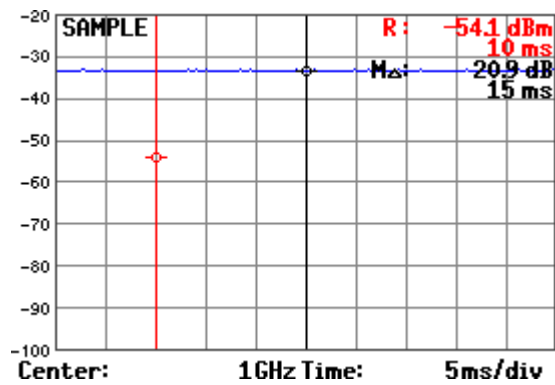

Activating M1
marker values as
reference points

- Press the **REF FIXED OFF** function key in the **REF FIXED** submenu.

The reference values (R) disappear from the screen and the M1 marker values are again activated. Marker 1 is positioned on the last reference point frequency on the trace and can again be moved, e.g. in the frequency-domain display mode.

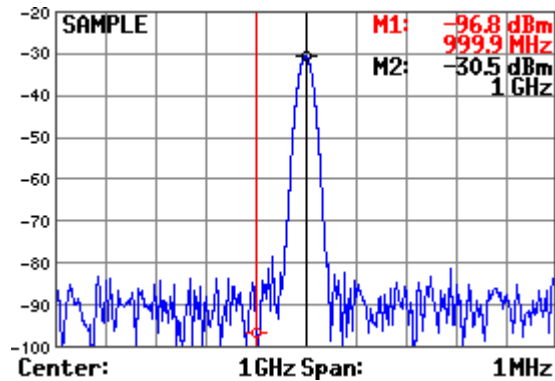

6.2.4 Setting the Bandwidths and the Sweep Time (BW/SWEEP Menu)

What the settings are for

You can set the resolution bandwidth (RBW), the video bandwidth (VBW) and the sweep time using the BW/SWEEP menu. The parameters determine the measurement procedure and can be coupled as a function of the SPAN or set independently. If the value is outside the diagram area, a small blue arrow pointing toward the marker appears in the bottom half of the measurement diagram.

Selecting the BW/SWEEP menu

- Select the **BW/SWEEP** menu with the **◀** or **▶** cursor key [6].

The menu name is highlighted and the appropriate functions are assigned to the function keys [13].

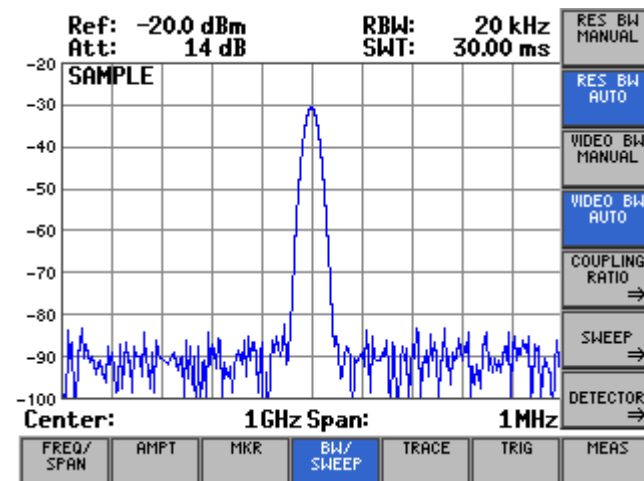

Function key assignment

RES BW MANUAL	Setting the resolution bandwidth manually	(↗ 6-119)
RES BW AUTO	Activating automatic resolution bandwidth setting	(↗ 6-119)
VIDEO BW MANUAL	Setting the video bandwidth manually	(↗ 6-120)
VIDEO BW AUTO	Activating automatic video bandwidth setting	(↗ 6-120)
COUPL RATIO →	Open submenu: Setting the RBW/VBW coupling ratio	(↗ 6-121)
SWEEP →	Open submenu: Setting the sweep time	(↗ 6-124)
DETECTOR →	Open submenu: Evaluation of the individual pixels of a trace	(↗ 6-128)

Note

The **RES BW MANUAL**, **RES BW AUTO** function keys and the **VIDEO BW MANUAL**, **VIDEO BW AUTO** function keys are selection keys. In other words, only one setting can be activated at any one time. The function key in question is highlighted. The RES BW AUTO and VIDEO BW AUTO functions are the default settings.

The **RES BW AUTO** function key is not available in the time-domain display mode (ZERO SPAN).

6.2.4.1 Setting the Resolution Bandwidth

Use

The span and the resolution bandwidth can be set independently. In the default setting, however, these two parameters are coupled to make operating the instrument easier. This setting is recommended for many applications because operating errors are prevented. To make certain measurements, it may be necessary to set the resolution bandwidth and the span independently. With the R&S FS315, you can manually set resolution bandwidths from 200 Hz to 20 MHz in a 1, 2, 3, 5, 10 sequence.

Setting the resolution bandwidth manually

1. Press the  function key in the  menu.

A selection field containing the available settings is displayed. The default setting is 3 MHz.

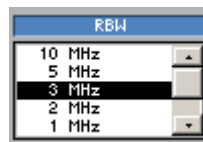

2. Select a resolution bandwidth with **rotary knob** [11].
3. Press the **ENTER key** [5] to close the selection field.
The new setting is saved and the resolution filter is configured.

Activating automatic resolution bandwidth setting

- Press the  function key in the  menu.

The resolution bandwidth is set to $\frac{1}{50}$ of the span. If the span is changed, the resolution bandwidth is adjusted automatically.



Note

The  function key is not available in the time-domain display mode (ZERO SPAN).

6.2.4.2 Setting the Video Bandwidth

Use

You can set a variety of video bandwidths to smooth the trace. You can set video bandwidths from 10 Hz to 20 MHz in a 1, 2, 3, 5, 10 sequence on the R&S FS315.

Setting the video bandwidth manually

1. Press the  function key in the  menu.

A selection field containing the available settings is displayed. The default setting is 10 MHz.

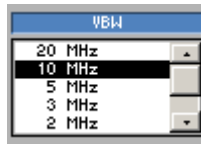

2. Select a video bandwidth with **rotary knob** [11].
3. Press the **ENTER** key [5] to close the selection field.
The new setting is saved and the selected video bandwidth is set.

Activating automatic video bandwidth setting

- Press the  function key in the  menu.

The R&S FS315's video bandwidth is set to three times the resolution bandwidth. If the resolution bandwidth is changed, the video bandwidth is adjusted automatically.

Within the permissible setting range, the video bandwidth is set to the value that is closest to three times the value of the resolution bandwidth.

The coupling ratio can be changed (↗ 6-121).

6.2.4.3 RBW, VBW and SPAN Coupling Ratio

What the settings are for

You can set the coupling ratio between the video bandwidth, the resolution bandwidth and the frequency display span using the COUPLING RATIO sub-menu.

Selecting the COUPLING RATIO submenu

- Press the **COUPL RATIO** function key in the **BW/ SWEEP** menu.

The submenu is opened and the appropriate functions are assigned to the function keys [13].

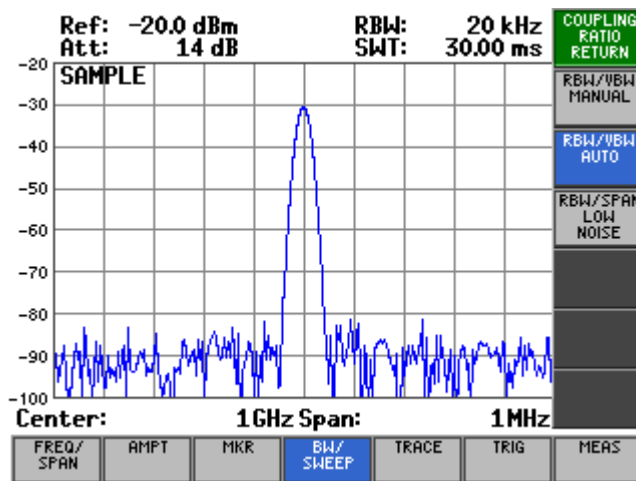

Function key assignment



Quitting the submenu



Setting the coupling ratio RBW/VBW manually

(↗ 6-122)



Activating the default setting for the coupling ratio RBW/VBW

(↗ 6-122)



Switching over the coupling RBW/SPAN to low noise

(↗ 6-123)



Note

The **RBW/VBW MANUAL** and **RBW/VBW AUTO** function keys are selection keys. In other words, only one setting can be activated at any one time. The function key in question is highlighted. The RBW/VBW AUTO function is the default setting.

6.2.4.3.1 Changing the Coupling Ratio RBW/VBW

Use

You can change the automatic coupling between resolution bandwidth (RBW) and the video bandwidth (VBW) by means of the RBW/VBW MANUAL function. This makes it possible to increase the display accuracy of the analyzer in comparison to the default setting (RBW/VBW AUTO).

Setting the coupling ratio manually

1. Press the  function key in the  submenu.

An entry field containing the current setting is displayed in the top left-hand corner. The default setting is 0.3.

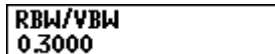

2. Enter a new value (↗ 5-57).

The entry range for the coupling ratio is:

$$0.001 \leq \text{RBW/VBW} \leq 1000$$

The new setting is saved and the VBW/RBW coupling ratio is set. If the resolution bandwidth is changed, the video bandwidth is adjusted automatically.

Activating the default setting for the coupling ratio

- Press the  function key in the  submenu.

The R&S FS315's video bandwidth is set to three times the resolution bandwidth.

6.2.4.3.2 Switching Over the Coupling RBW/SPAN to Low Noise

Use You can change the automatic coupling between frequency display span (SPAN) and resolution bandwidth (RBW) by means of the RBW/SPAN LOW NOISE function. This makes it possible to increase the measurement sensitivity of the analyzer in comparison to the normal setting.

If the span is < 1 GHz in the Low Noise setting, the setting for the resolution bandwidth is as shown in the following table:

SPAN	RBW
SPAN > 1 GHz	1 MHz
1 GHz ≥ SPAN > 50 MHz	300 kHz
50 MHz ≥ SPAN > 10 MHz	100 kHz
10 MHz ≥ SPAN > 5 MHz	30 kHz
5 MHz ≥ SPAN > 1 MHz	10 kHz
1 MHz ≥ SPAN > 200 kHz	3 kHz
200 kHz ≥ SPAN > 100 kHz	1 kHz
100 kHz ≥ SPAN > 50 kHz	500 Hz
50 kHz ≥ SPAN > 20 kHz	300 Hz
20 kHz ≥ SPAN > 1 kHz	200 Hz

Switching on the coupling RBW/SPAN LOW NOISE

- Press the **RBW/SPAN LOW NOISE** function key in the **COUPL RATIO** submenu. The ratio between frequency display span (SPAN) and resolution bandwidth (RBW) is set consequently.

The setting is indicated by the letters LN next to the RBW display.

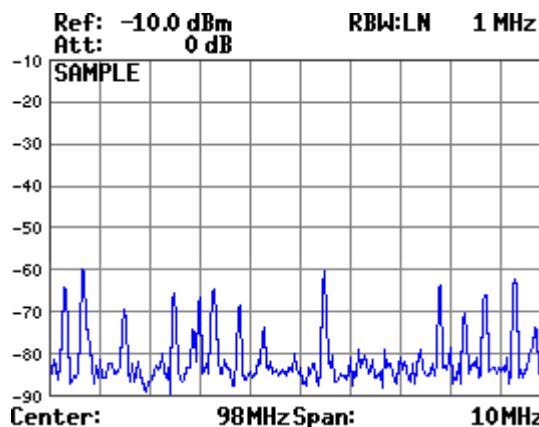

Switching off the coupling RBW/SPAN LOW NOISE

- Press the **RBW/SPAN LOW NOISE** function key in the **COUPL RATIO** submenu. The ratio between frequency display span (SPAN) and resolution bandwidth (RBW) is set normally and provides the shortest possible sweep times for a set SPAN.

The letters LN next to the RBW display are blanked out.

6.2.4.4 Setting the Sweep

What the settings are for

Selecting the SWEEP submenu

You can select the type of sweep and the sweep time from the SWEEP submenu.

- Press the **SWEEP** function key in the **BW/SWEEP** menu.

The submenu opens and the appropriate functions are assigned to the function keys [13].

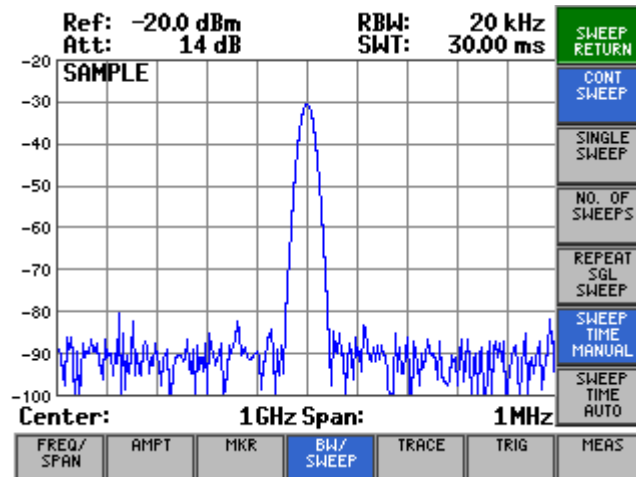

Function key assignment

SWEEP RETURN	Quitting the submenu	
CONT SWEEP	Starting the continuous sweep	(↗ 6-125)
SINGLE SWEEP	Performing an n-times sweep	(↗ 6-125)
NO. OF SWEEPS	Setting the number of sweeps	(↗ 6-125)
REPEAT SGL SWEEP	Repeating an n-times sweep	(↗ 6-126)
SWEEP TIME MANUAL	Setting the sweep time manually	(↗ 6-126)
SWEEP TIME AUTO	Activating automatic sweep time setting	(↗ 6-126)

Note

The **CONT SWEEP**, **SINGLE SWEEP** function keys and the **SWEEP TIME MANUAL**, **SWEEP TIME AUTO** function keys are selection keys. In other words, only one setting is activated at any one time. The function key in question is highlighted. The COUNT SWEEP and SWEEP TIME AUTO functions are the default settings.

The **RES BW AUTO** function key is not available in the time-domain display mode (ZERO SPAN).

6.2.4.4.1 Selecting the Frequency Sweep

Use Frequency sweep is the process where the resolution filter covers a defined frequency range. Sweeps may be performed continuously (CONT SWEEP) or once (SINGLE SWEEP).

Starting a continuous sweep

- Press the  function key in the  submenu.

The sweep repeats continuously when the trigger event is detected (↗ 6-140).

Performing an n-times sweep

- Press the  function key in the  submenu.

An n-times sweep is started when the trigger event is detected. The number of sweeps is specified with the NO. OF SWEEPS setting (↗ below).

When you repeatedly press the  function key, the previous trace is cleared and a new frequency sweep (n times) is started.

Setting the number of sweeps

- Press the  function key in the  submenu.

An entry field containing the current setting is displayed in the top left-hand corner. The default setting is 0 (endless sweeps).

No. Of Sweeps
0

- Enter a new value (↗ 5-57).

The entry range for the number of sweeps is:

$$0 \leq \text{Cycle Count} \leq 32767$$

The new setting is saved and when a single sweep has been started, the sweep is repeated n times.

Repeating an n-times sweep

- Press the  function key in the  submenu.

An n-times sweep is started when the trigger event is detected. The trace is not cleared on completion of the sweep as would be the case with the single-sweep function.

This is most relevant in relation to the TRACE AVERAGE and HOLD functions if measured values that have already been recorded have to be taken into account for averaging and finding the minimum/maximum.

6.2.4.4.2 Setting the Sweep Time

Use

In normal span (SPAN > 0 Hz) the sweep time is the time taken by the resolution filter set to a specific bandwidth (RBW) to sweep a particular frequency range or span. In the default setting, the sweep time is coupled to the span (SPAN), the resolution bandwidth (RBW) and the video filter (VBW).

In zero span (SPAN = 0 Hz) the sweep time determines the length of the time interval displayed on the screen. Because it is not required in zero span to wait until RBW and VBW have been settled the sweep time can be much shorter than in normal span for the same filter settings.

Setting the sweep time manually (normal span)

1. Press the  function key in the  submenu.

An entry field containing the current setting is displayed in the top left-hand corner. The default setting is 15.5 ms. The default setting is at FULL SPAN (3 GHz) and at RBW = 1 MHz:30 ms.

Sweep Time
30 ms

2. Enter a new value (↗ 5-57).

The entry range for the sweep time is (SPAN > 1 kHz):

$$30 \text{ ms} \leq \text{Sweep Time} \leq 1000 \text{ s}$$



The new setting is saved and the new sweep time activated.



Note

The maximum sweep time of 1000 s can be reached only for SPAN > 4 MHz. For smaller spans the maximum sweep time is reduced depending on the setting for RBW.

Setting the sweep time manually (zero span)

1. Change to Zero-Span (↗ 6-77).
2. Press the  function key in the  submenu.

An entry field containing the current setting is displayed in the top left-hand corner. The default setting is 50 ms.

Sweep Time
50 ms

3. Enter a new value (↗ 5-57).

The entry range for the sweep time is (SPAN > 1 kHz):

$$5 \text{ } \mu\text{s} \leq \text{Sweep Time} \leq 10 \text{ s}$$

The new setting is saved and the new sweep time activated.

Activating automatic sweep time setting

The automatic sweep time setting is only available in the normal span mode.

- Press the  function key in the  submenu.

The sweep time is coupled to the span, the resolution bandwidth (RBW) and the video bandwidth (VBW). The sweep time is automatically adjusted if either the span, the RBW or the VBW are changed.

The R&S FS315 always selects the shortest possible sweep time consistent with valid results. The maximum level error trade-off for a longer sweep time is < 0.1 dB. If you do not want the additional bandwidth and level error, set the sweep time manually to three times the suggested value (↗ above).

6.2.4.5 Evaluating the Individual Pixels of a Trace

What the settings are for

The detectors are used to reduce the number of sampled level measurements to be displayed on the screen to 250 pixels. A total of six different detectors are available in the R&S FS315. The default setting is the MAX PEAK detector. The MAX PEAK detector and MIN PEAK detector select the maximum and minimum value from the measured level values and display them on screen. With the SAMPLE detector, however, the measurement values are displayed without prior evaluation. The RMS detector calculates the effective power (rms value) from the measured level values for each pixel, and the AVERAGE detector calculates the average value.

Selecting the DETECTOR submenu

- Press the **DETECTOR** function key in the **BW/SWEEP** menu.

The submenu opens and the appropriate functions are assigned to the function keys [13].

Function key assignment

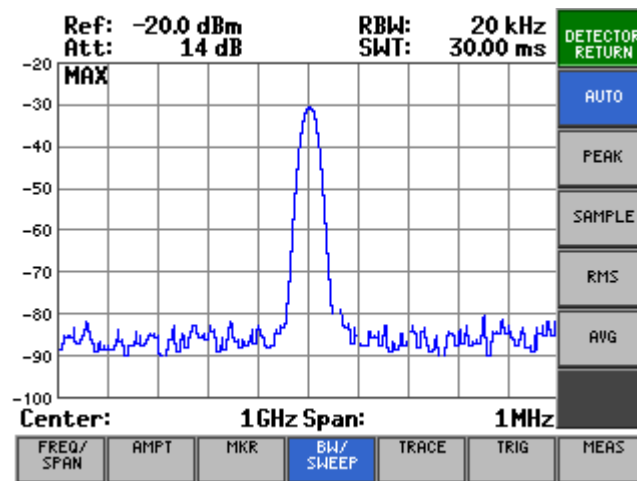

DETECTOR RETURN

Quitting the submenu

PEAK

PEAK detector is active

(↗ 6-129)

SAMPLE

SAMPLE detector is active

(↗ 6-129)

RMS

RMS detector is active

(↗ 6-129)

AVG

AVERAGE detector is active

(↗ 6-129)

Note

The function keys are selection keys. In other words, only one setting can be activated at any one time. The function key in question is highlighted. The MAX PEAK function is the default setting.

6.2.4.5.1 Selecting the Detector

Use

- **MAX/MIN PEAK**

The peak detectors determine the largest of all positive (MAX PEAK) or the smallest of all negative (MIN PEAK) peak values of the measured levels for the individual frequencies, which are represented by one of the 250 pixels. It repeats this for all other pixels so that a considerably larger number of individual measurements are taken into consideration for displaying the spectrum for broad frequency spans despite the limited resolution of the display.

The MAX PEAK detector is recommended if pulse-like signals are to be measured.

The MIN PEAK detector makes weak sinewave signals clearly visible in noise. The pulse signals are suppressed in composite signals consisting of sinewave and pulse signals.

- **SAMPLE**

The SAMPLE detector passes on all samples without further evaluation and displays them immediately. Data reduction (i.e. the combination of measurement values of adjacent frequencies or time samples) is not performed here. If a frequency sweep produces more measurement values than can be displayed, measurement values will be discarded. Discrete signals may be lost as a result.

The SAMPLE detector is therefore only recommended for span/RBW ratios of approx. 250 since no signals are suppressed at such ratios. (Example: Span = 1 MHz, -> min. RBW = 5 kHz.)

The SAMPLE detector is used if uncorrelated signals such as noise are to be measured.

- **RMS**

The RMS detector generates the rms value of the measurement values within a pixel. It therefore always returns the signal power irrespective of the signal shape. To do so, the mean square of all sampled level values is calculated during the sweep of a pixel.

Note: The video bandwidth (VBW) must be at least 3 times the resolution bandwidth (RBW) so that the rms value of the measurement signal is not corrupted by the video filtering.

- **AVG**

The AVERAGE detector generates the average value of the measurement values within a pixel. Unlike the RMS detector, it returns the linear average of all sampled level values during the sweep of a pixel.

It involves the same dependencies as the RMS detector (↗ above).

Selecting detector

When the R&S FS315 is switched on, trace 1 is active and is displayed in the CLEAR/WRITE display mode. The MAX PEAK detector is active (default setting).

1. Press the appropriate **function key** in the  **menu**.

Pressing the PEAK function key opens a selection field containing predefined settings. The default setting is Max Peak.

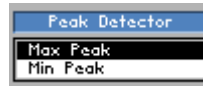

2. Select a setting with the **rotary knob** [11].
3. Press the **ENTER key** [5] to close the selection field.

The new setting is saved and the selected video bandwidth is set. The active detector is displayed in the top left-hand corner of the measurement diagram:

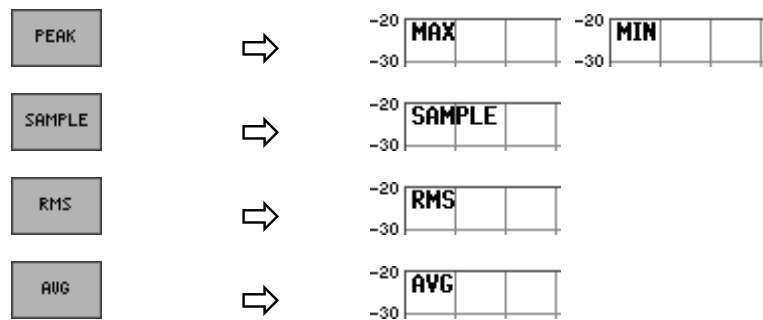

6.2.5 Measured-Value Display (TRACE Menu)

What the settings are for

Using the TRACE menu, you can apply various display modes to the input-signal results. Two traces (Trace 1, Trace 2) are provided for this purpose.

Selecting the TRACE menu

- Select the **TRACE** menu with the ◀ or ▶ cursor key [6].

The menu name is highlighted and the appropriate functions are assigned to the function keys [13].

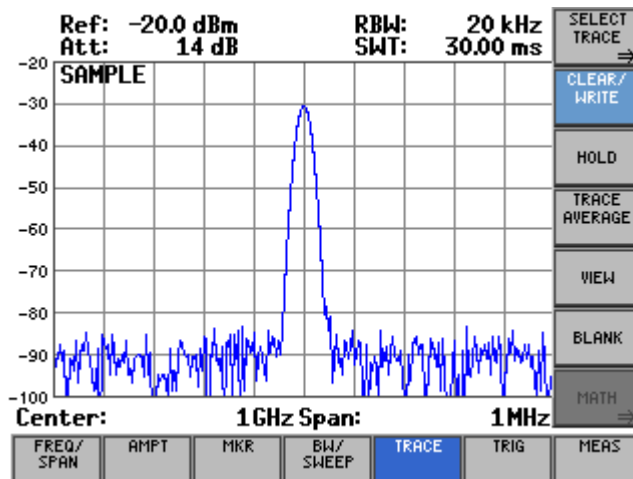

Function key assignments

	Open submenu: Selecting the active trace	(↗ 6-132)
	Trace display mode: Overwrite mode	(↗ 6-135)
	Trace display mode: Min/Max Hold	(↗ 6-135)
	Trace display mode: Averaging	(↗ 6-135)
	Freezing the trace	(↗ 6-135)
	Blanking out the trace	(↗ 6-135)
	Open submenu: Trace difference function	(↗ 6-138)



Note

The function keys , , , or are selection keys. In other words, only one setting can be active at any one time. The function key in question is highlighted. The CLEAR/WRITE function is the default setting.

The function key is only available when both traces are on (↗ 6-132).

6.2.5.1 Selecting the Active Trace

What the settings are for

Via the SELECT TRACE submenu, you can activate a second trace and select the current trace (Trace 1, Trace 2) to which all the following settings will be applied.

Selecting the SELECT TRACE submenu

- Press the  function key in the  menu.

The submenu opens and the appropriate functions are assigned to the function keys [13].

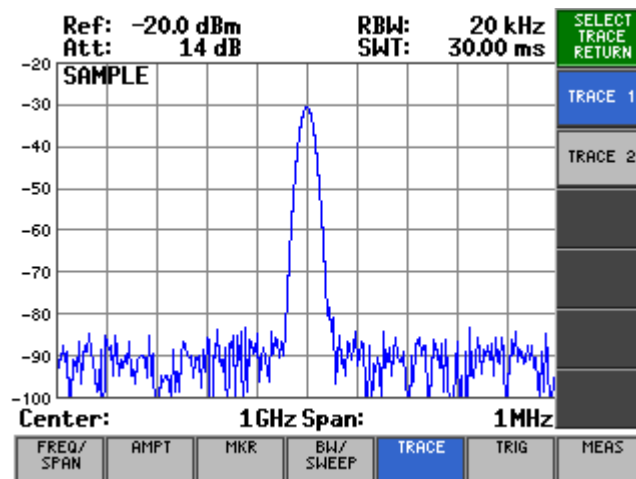

Function key assignment



Quitting the submenu



Turn on and activate Trace 1



(↗ 6-133)



Turn on and activate Trace 2

(↗ 6-133)

Note

The function keys  and  are selection keys. In other words, only one setting can be active at any one time. The function key in question is highlighted. The TRACE 1 function is the default setting.

6.2.5.1.1 Activating Traces

Use

The measured values for the input signal can be displayed using two different traces (Trace 1 and Trace 2). However, only one trace is active and can be used at any one time. The other trace is frozen and displayed. This means that the two traces can be compared.

Activating Trace 1

When you switch on the R&S FS315, Trace 1 is automatically turned on and activated. Trace 2 is turned off. All the settings are for Trace 1.

- In the **SELECT TRACE** submenu, press the **TRACE 1** function key if Trace 2 is turned on and active.

Trace 1 becomes the active trace. All the following settings are for this trace. The current display mode, e.g. MAX HOLD (MAX, ↗ 6-135), is displayed in the top left of the diagram area in the trace colour:

MAX

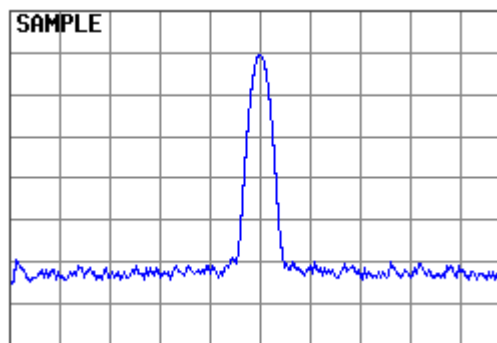

Turning on and activating Trace 2

When the R&S FS315 is turned on, Trace 2 is turned off. When the trace is called for the first time, the CLEAR/WRITE display mode is set.





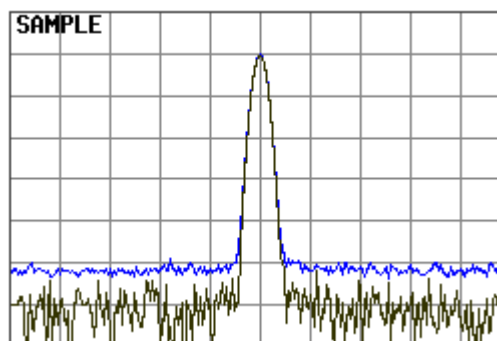

- Press the **TRACE 2** function key in the **SELECT TRACE** submenu.

Trace 2 becomes the active trace. All subsequent settings are for this trace. In the top left of the diagram area, the current display mode is shown in the trace colour, e.g. CLEAR/WRITE (CLR, ↗ 6-135):

CLR



**Turning off
Trace 2**

1. Press the  function key in the  submenu.
Trace 2 is now active.
2. Press the  function key in the  menu.
Trace 2 is blanked out.
3. Press the  function key in the  submenu.
Trace 1 is activated and Trace 2 is turned off.

**Note**

The current values are displayed in the trace colour. This means that you can quickly tell which trace has been activated.

6.2.5.2 Displaying the Active Trace

Use

You can select the following settings for displaying the active trace:

- **CLEAR/WRITE**

Overwrites the trace on every frequency sweep.

- **HOLD**

Displays the minimum/maximum over several sweeps.

This function is used to find the minimum/maximum value of a signal over several frequency sweeps (↗ CONT. SWEEP, 6-125). This is particularly useful in the case of modulated or pulse-like signals. On every sweep, more data is added to the signal spectrum until all the signal components are displayed using a type of “envelope curve”.

- **AVERAGE**

Displays the average over several frequency sweeps.

This function is used to display the signal average over several frequency sweeps. This function is most useful for sine signals which have been degraded by noise. Essentially, noise can be eliminated by averaging the samples over several frequency sweeps.

After a measurement has been performed, the trace can be frozen (**VIEW**) or blanked out (**BLANK**).

Displaying current measured values

When the R&S FS315 is switched on, Trace 1 is active and is displayed in the CLEAR/WRITE display mode.

- Press the  function key in the  menu.

The overwrite mode is set. This means that the trace is overwritten on every frequency sweep.

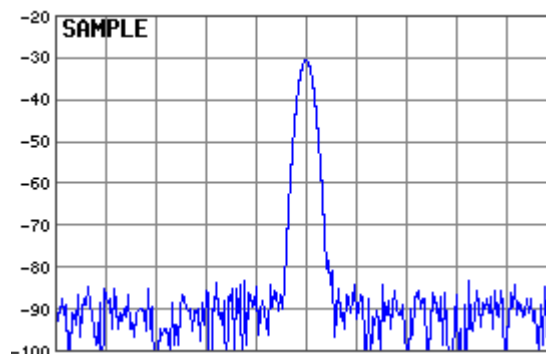

Displaying signal minimum/maximum

1. Press the **HOLD** function key in the **TRACE** menu.

A selection field containing the available settings is displayed. The default setting is Min Hold.



2. Select a settings for displaying the active trace with **rotary knob** [11].
3. Press the **ENTER** key [5] to close the selection field.

The MIN/MAX function is activated. This means that, after every sweep, the R&S FS315 only transfers the new measured value to the measured value memory if it is smaller/greater than the previous value. The current display mode, e. g. MAX, is displayed in the top left of the diagram area.

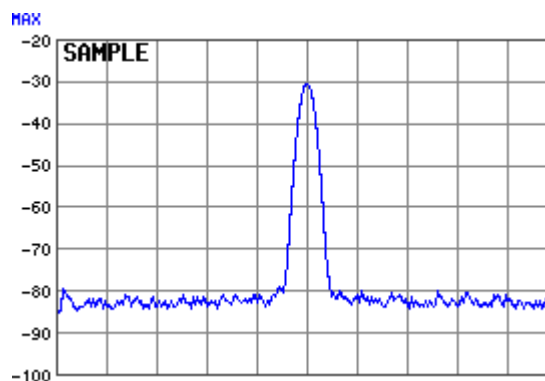

Displaying average values

1. Press the **TRACE AVERAGE** function key in the **TRACE** menu.

Averaging is activated. The average is taken over several frequency sweeps.

An entry field for entering the number of frequency sweeps is displayed in the top left-hand corner. The default setting is 0.

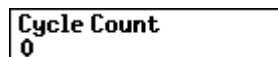

2. Enter a new value (↗ 5-57).

The entry range for the number of frequency sweeps is:

$$0 \leq \text{Sweep Count} \leq 100$$

where:

Sweep Count = 0	Continuous averaging
Sweep Count = 1	No averaging
Sweep Count > 1	Averaging over the specified number of frequency sweeps

If the continuous sweep mode (↗ CONT. SWEEP, 6-125) has been selected, continuous averaging is automatically activated when the specified number of sweeps has been performed.

The new setting is saved. Averaging is started and the result is displayed. The current display mode **AVG** is shown in the top left of the diagram area.

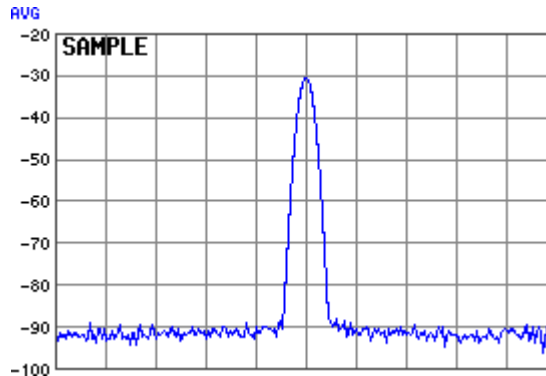

Freezing traces

1. Press the **VIEW** function key in the **TRACE** menu.
The current trace is frozen and displayed.
2. Press the **CLEAR/ WRITE**, **HOLD** or **TRACE AVERAGE** function key in the **TRACE** menu when you want to update the trace.

Blanking traces

- Press the **BLANK** function key in the **TRACE** menu.
The trace is blanked out of the measurement diagram.
If the trace has been frozen previously at some time, it can be returned to the display by pressing the **VIEW** function key. Otherwise, the trace is deleted.

6.2.5.3 Trace Difference Function



Note

The  function key is available only if both traces are turned on (↗ 6-132).

What the settings are for

You can activate the difference function for two traces (Trace 1, Trace 2) from the MATH submenu and use this function to analyze the input signal.



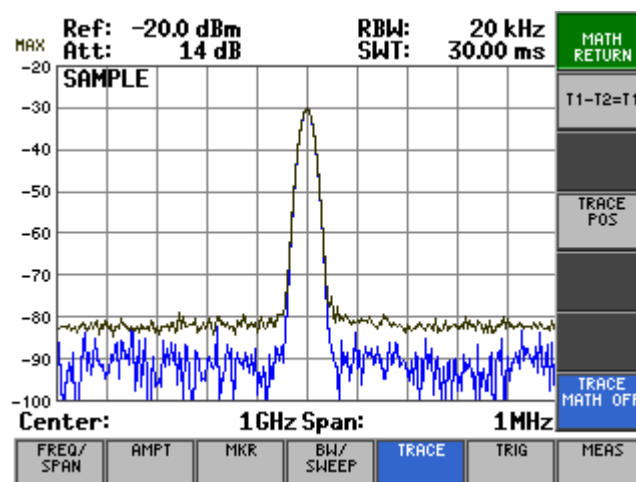

Selecting the MATH submenu

- Press the  function key in the  menu.

The submenu opens and the appropriate functions are assigned to the function keys [13].



Function key assignment

	Quitting the submenu	
	Activating the trace difference function	(↗ 6-139)
	Repositioning Trace 1 (result)	(↗ 6-139)
	Turning off the trace difference function	(↗ 6-139)

6.2.5.3.1 Activating the Trace Difference Function

Use

You can use the R&S FS315's MATH function to directly determine differences between signals by forming the difference of two traces. The new reference for the difference trace is in the center of the measurement diagram (50 %). The difference trace can be moved within the measurement diagram by changing the reference.

Turning on the difference function

1. Press the **T1-T2=T1** function key in the **MATH** submenu.

The new trace, Trace 1, is the difference of the old traces: $T1 = T1 - T2$.

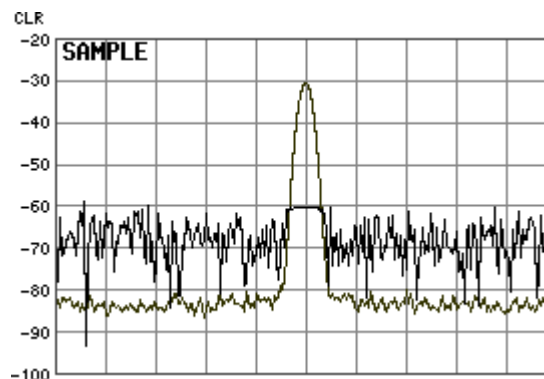

Repositioning Trace 1 (result)

2. Press the **TRACE POS** function key in the **MATH** submenu.

An entry field for entering the trace position is displayed in the top left-hand corner. The default setting is 50 %.

Trace Pos
50 %

3. Enter a new value (↗ 5-57).

The entry range for the reference-point time is:

$$0\% \leq \text{Trace Pos} \leq 100\%$$

The new setting is saved and displayed in the diagram area.

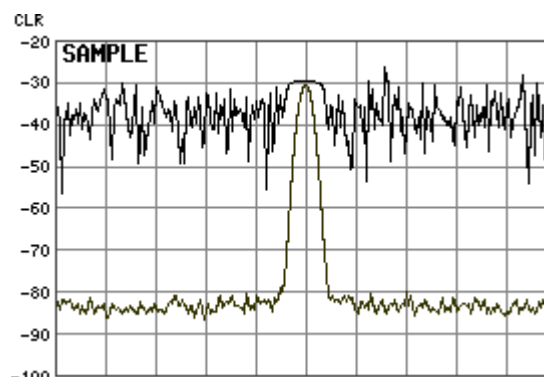

Turning off the trace difference function

- Press the **TRACE MATH OFF** function key in the **MATH** submenu.

The difference function for the two traces ($T1=T1-T2$) is turned off and the two traces are again displayed independently.



Note

While a math function is being performed on both traces, it is not possible to change the active trace.

6.2.6 Triggering Measurements (TRIG Menu)

What the settings are for

From the TRIG menu, you can select a variety of trigger sources. You can set the trigger edge and the measurement time for external trigger signals (TTL).

Selecting the TRIG menu

- Select the **TRIG** menu with the ◀ or ▶ cursor key [6].

The menu name is highlighted and the appropriate functions are assigned to the function keys [13].

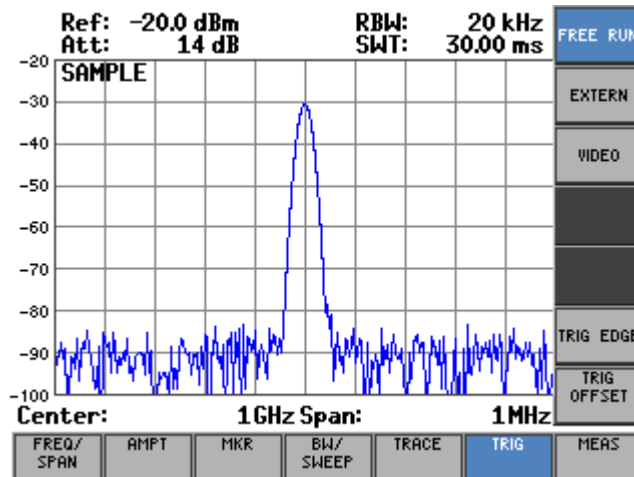

Function key assignment

FREE RUN	Free-running measurement. No explicit triggering of the start of measurement (↗ 6-141)
EXTERN	Triggering by an external TTL signal (↗ 6-142)
VIDEO	Triggering by the display level (↗ 6-141)
TRIG EDGE	Selecting the trigger slope for external trigger signal (↗ 6-142)
TRIG OFFSET	Enter trigger offset (↗ 6-142)

Note

The **FREE RUN**, **EXTERN** and **VIDEO** functions keys are selection keys. In other words, only one setting can be activated at any one time. The function key in question is highlighted. The FREE RUN function is the default setting.

The **VIDEO** function key is available only in the time-domain display mode (ZERO SPAN).

6.2.6.1 Internal Trigger Sources

Use Depending on the measurement, you can use a variety of criteria for triggering measurements in the frequency domain (SPAN > 0) or in the time domain (ZERO SPAN).

- Free-running triggering
- Triggering by the display level (only in the time domain, ZERO SPAN)

Free-running triggering

Suitable for measurements on stationary signals where a time reference is not necessary.

- Press the **FREE RUN** function key in the **TRIG** menu.

There is no explicit triggering of the start of measurements. When one measurement has been completed, another is started immediately.

Triggering by display level (only available in time domain, ZERO SPAN)

If the video trigger is used, triggering on signals whose carrier amplitude is a function of time is possible. This means that measurements can be made on bursts which are often encountered in mobile radio applications.

1. Press the **VIDEO** function key in the **TRIG** menu.

A horizontal trigger line is displayed in the diagram area. The associated trigger level is displayed above the trigger line on the left.

An entry field for entering the trigger level is also displayed. The trigger level can be set to between 0 % and 100 % of the diagram height. The default setting is 50 % corresponding to e. g. -60.0 dBm.

Trig. Video	%
50	

2. Enter a new value (↗ 5-57).

The entry range for the trigger level is:

$$0 \% \leq \text{Trigger Video} \leq 100 \%$$

The trigger line is in its new position and the current trigger level indicates how large the input level must be to start the next measurement.

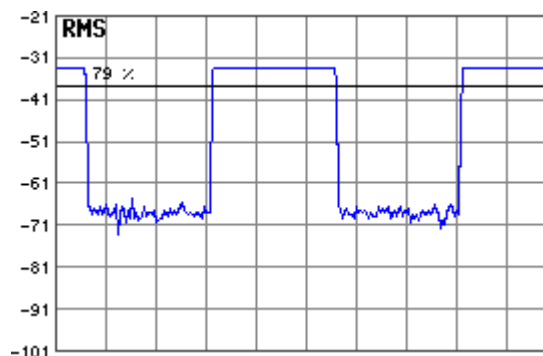

6.2.6.2 External Trigger Sources

Use For certain measurements, you can use an external TTL signal (squarewave signal) as a trigger. The trigger period is user-selectable. The R&S FS315 allows you to set triggering on a rising or on a falling edge of the squarewave.

External triggering 1. Connect the external signal source to the R&S FS315's input connector [15].

2. Press the **EXTERN** function key in the **TRIG** menu.

Triggering is executed by means of the external TTL signal (squarewave signal).

Setting trigger slope

3. Press the **TRIG EDGE** function key in the **TRIG** menu.

A selection field containing the available settings is displayed. The default setting is Rising.



4. Select a resolution for the internal frequency counter with **rotary knob** [11].

5. Press the **ENTER** key [5] to close the selection field.

The new setting is saved and triggering is executed at the selected trigger slope.

6.2.6.3 Setting a Trigger Offset

Use If the time difference between the signal to be measured and the trigger event is too great ($t > t_{\text{sweep}}$), you can enter a time (trigger offset) by which the trigger point will be advanced or delayed.

Entering a trigger offset

1. Press the **TRIG OFFSET** function key in the **TRIG** menu.

An entry field containing the current setting is displayed in the top left-hand corner. The default setting is 0.000 ms.

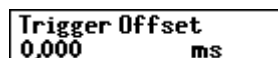

2. Enter a new value (↻ 5-57).

The entry range for the trigger offset is:

$$0 \text{ s} \leq \text{Trigger Delay} \leq 100 \text{ ms} \quad (\text{SPAN} > 0)$$

$$-t_{\text{sweep}} \leq \text{Trigger Offset} \leq 100 \text{ ms} \quad (\text{ZERO SPAN})$$

where t_{SWEEP} - current sweep time (↻ 6-126)

The new setting is saved and the trigger offset is added to the trigger point.

6.2.7 Measurement Functions (MEAS Menu)

What the settings are for

From the MEAS menu, you can select the following settings:

- Power measurement in the time domain
- Channel power measurement and measurement of the occupied bandwidth
- Tracking generator settings
- AM/FM demodulator settings
- TOI
- Selection of transducer factors





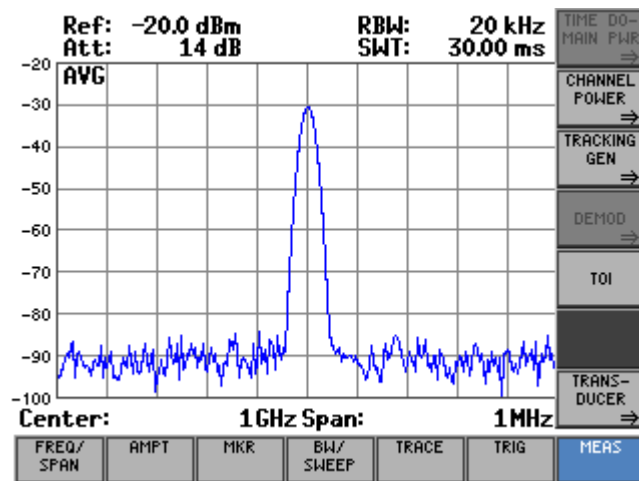

Selecting the MEAS menu

- Select the **MEAS** menu with the ◀ or ▶ cursor key [6].



The menu name is highlighted and the appropriate functions are assigned to the function keys [13].





Function key assignment

	Open submenu: Measure the power in the time domain (ZERO SPAN)	(↗ 6-144)
	Open submenu: Measure the channel power and the occupied bandwidth	(↗ 6-148)
	Open submenu: Configure the tracking generator	(↗ 6-152)
	Open submenu: AM/FM demodulation	(↗ 6-160)
	Measure the third-order intercept point	(↗ 6-162)
	Open submenu: Activate the transducer function	(↗ 6-164)

Note

The  and  function keys are only available in the time domain (ZERO SPAN).



The  and  function keys are only available in the normal frequency.

6.2.7.1 Measuring the Power in the Time Domain

What the settings are for

From the TIME DOMAIN PWR submenu, you can determine the trace section for which the power measurement is to be performed. You can measure either the mean square (RMS), arithmetic mean (MEAN) or maximum value (PEAK).





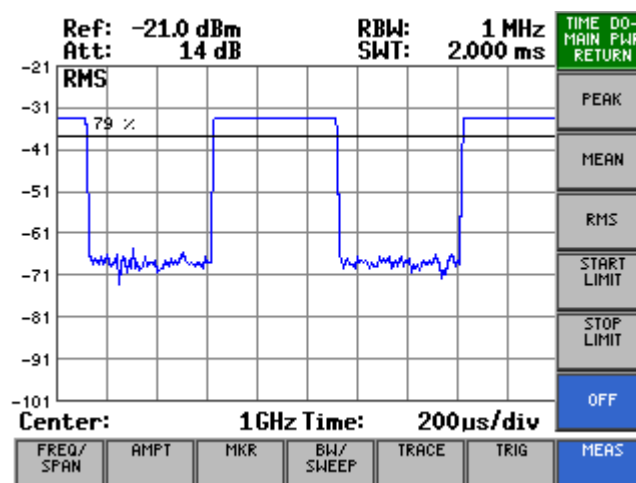

Selecting the TIME DOMAIN PWR submenu

1. Switch the R&S FS315 to the time-domain mode (ZERO SPAN, ↗ 6-77).
2. Press the  function key in the  menu.

The submenu opens and the appropriate functions are assigned to the function keys [13].



Function key assignment

	Quitting the submenu	
	Output the peak power within the section	(↗ 6-145)
	Output the mean power within the section	(↗ 6-145)
	Output the mean square within the time domain	(↗ 6-145)
	Insert a vertical line to limit the lower (left) part of a section	(↗ 6-145)
	Insert a vertical line to limit the upper (right) part of a section	(↗ 6-145)
	Switch off the power measurement	(↗ 6-145)

6.2.7.1.1 Measuring the Power

Use

By using the "Time Domain Power" measurement function, the R&S FS315 determines in the time domain (ZERO SPAN) the power of the signal by integrating the pixels within the selected section. This allows you to measure the power of TDMA signals, for example, during the transmission phase or during the mute phase. You can measure either the mean square (RMS), the mean power (MEAN) or the peak power (PEAK).

If both the switch-on and the switch-off phase of a burst signal are displayed, you can limit the measurement range to the transmission phase or the mute phase by means of the vertical lines. Since both phases are measured separately, you can determine the S/N power ratio of a TDMA signal, for example.

Activating the measurement

1. Press the **PEAK** function key in the **TIME DO-MAIN PWR** submenu.

The maximum power is measured within the limit lines T1 and T2 and displayed in the measurement diagram (PEAK:). In the default setting, these are the left (T1) and the right (T2) limit lines of the measurement diagram.

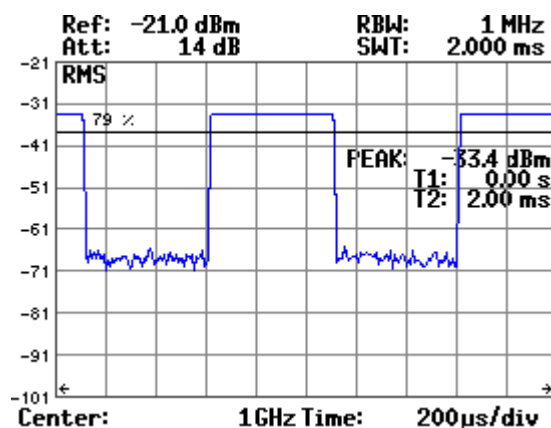

2. Press the **MEAN** function key in the **TIME DO-MAIN PWR** submenu.

The mean power is measured within the limit lines T1 and T2 and displayed in the measurement diagram (MEAN:). In the default setting, these are the left and the right limit lines of the measurement diagram.

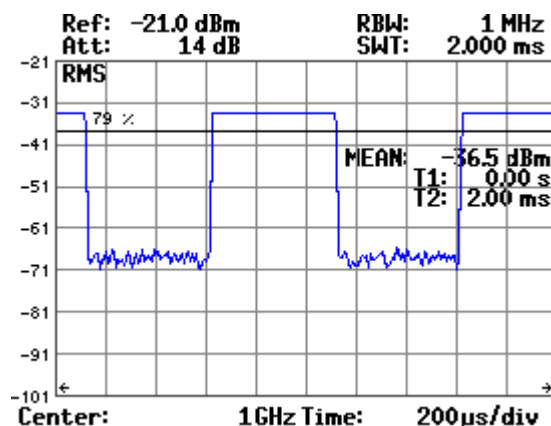

3. Press the **RMS** function key in the **TIME DO-MAIN PWR** submenu.

The mean square is measured within the limit lines T1 and T2 and displayed in the measurement diagram (RMS:). In the default setting, these are the left and the right limit lines of the measurement diagram.

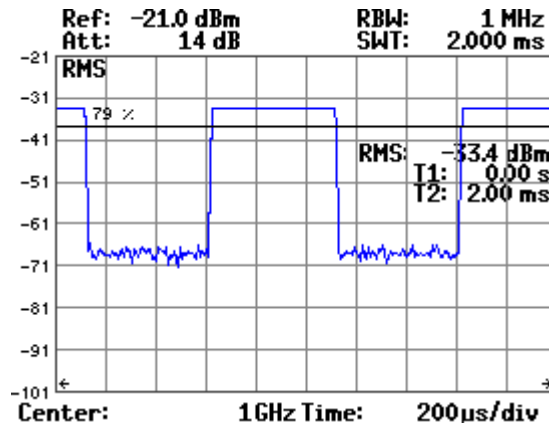

Changing the measurement range (limit lines)

1. Press the **START LIMIT** function key in the **TIME DO-MAIN PWR** submenu.

An entry field containing the current setting of the limit line is displayed. The default setting is the left side of the diagram.

2. Enter a new value (↵ 5-57).

The entry range for the position of the limit line is:

$$0s \leq \text{Start Limit} \leq t_{\text{SWEEP}} \quad \text{and} \quad T1 < T2$$

within t_{SWEEP} - current sweep time (↵ 6-126)

T1 - left limit line

T2 - right limit line

The current position T1 of the left limit line and the new measured parameter are displayed in the parameter field.

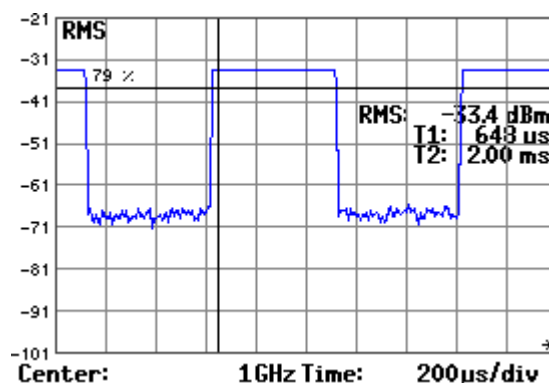

3. Press the **STOP LIMIT** function key in the **TIME DO-MAIN PWR** submenu.

An entry field containing the current setting of the limit line is displayed in the top left-hand corner. The default setting is the right side of the diagram.

Stop Limit
2.000 ms

4. Enter a new value (↗ 5-57).

The entry range for the position of the limit line is:

$$0s \leq \text{Start Limit} \leq t_{\text{SWEEP}} \quad \text{and} \quad T1 < T2$$

within t_{SWEEP} - current sweep time (↗ 6-126)

T1 - left limit line

T2 - right limit line

The current position T2 of the right limit line and the new measured parameter are displayed in the parameter field.

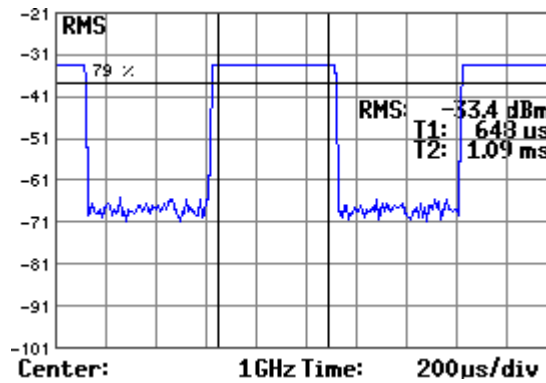

Deactivating the measurement

- Press the **OFF** function key in the **TIME DO-MAIN PWR** submenu.

The "Time Domain Power" measurement function is deactivated.

6.2.7.2 Measuring the Channel Power

What the settings are for

From the CHANNEL POWER submenu, you can measure the channel power for a predefined channel bandwidth or determine the occupied bandwidth (OBW).



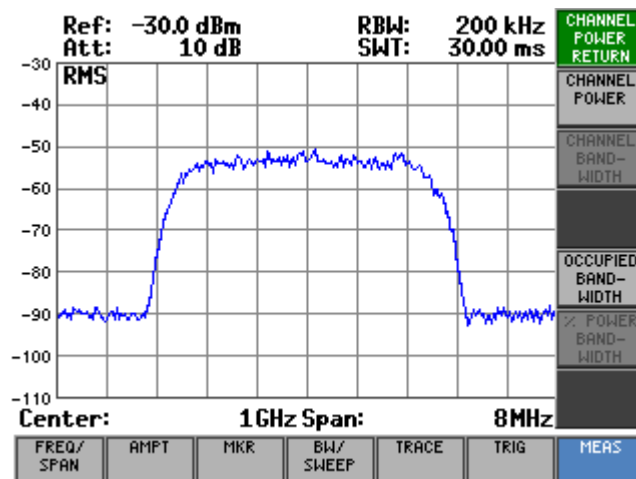

Selecting the CHANNEL POWER submenu

- Press the  function key in the  menu.

The submenu opens and the appropriate functions are assigned to the function keys [13].





Function key assignment

	Quitting the submenu	
	Measure the channel power	(↗ 6-149)
	Set the channel bandwidth	(↗ 6-149)
	Measure the occupied bandwidth	(↗ 6-151)
	Set the power bandwidth	(↗ 6-151)



Note



The  and  functions keys are selection keys. In other words, only one setting can be activated at any one time. The function key in question is highlighted. The CH POWER function is the default setting.

6.2.7.2.1 Measuring the Channel Power

Use

When the channel power is measured, the displayed level values are integrated within a predefined bandwidth. In combination with the RMS detector, this allows the rms value of a transmit signal to be determined. The channel power is defined by the set center frequency, the set channel bandwidth and the trace detector.

Measuring channel power

1. Set the center frequency according to the nominal channel frequency (↗ 6-73).
2. Set the frequency span so that it is approx. 2 to 3 times larger than the channel bandwidth (↗ 6-75).
3. Set the resolution bandwidth to approx. $\frac{1}{20}$ of the occupied channel bandwidth (↗ 6-119).
4. Set the CHANNEL BANDWIDTH (↗ below).
5. Press the  function key in the  submenu.

The measurement is performed by adding together the powers at the display points within the specified bandwidth and the result is then displayed in the measurement diagram.

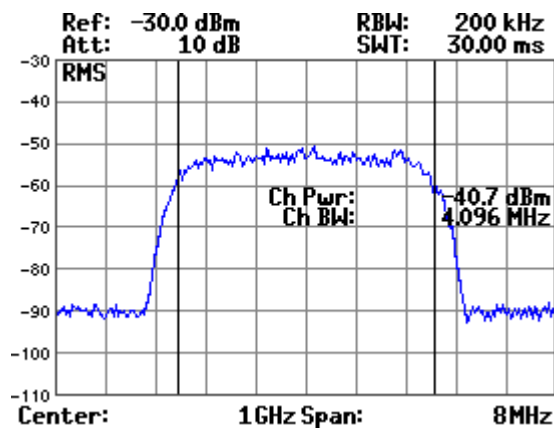

Changing the bandwidth

1. Press the  function key in the  submenu.

An entry field containing the current setting is displayed in the top left-hand corner. The default setting is "current Span".

Channel Bandwidth
8.000000 MHz

2. Enter a new value (↗ 5-57).

The entry range for the bandwidth is:

$$1.5 \text{ kHz} \leq \text{Channel Bandwidth} \leq \text{Span}$$

The current bandwidth is indicated by vertical lines. If the set bandwidth is greater than the current span, the message "Range!" appears and no measurement is performed.

A new measurement is performed within the new bandwidth and the result is shown in the measurement diagram (↗ above).

Correct power measurement of noise signals

To ensure that power measurements are performed correctly (especially in the case of noise signals) and, therefore, that the effective power can be measured, it is important to make the following settings:

- **RBW** (↗ 6-119)
 << occupied bandwidth (approx. $\frac{1}{20}$ of the occupied bandwidth: typ. 30 kHz or 100 kHz for W-CDMA)
- **VBW** (↗ 6-120)
 = 3 x RBW
- **Detector** (↗ 6-129)
 = RMS
- **Span** (↗ 6-75)
 = 2 - 3 x channel bandwidth

Measurement bandwidths (RBW) for various mobile radio systems (standard)

Standard	Channel bandwidth	Channel spacing	RBW
3GPP W-CDMA	3.84 MHz	5 MHz	30 kHz
TDS-CDMA	1.28 MHz	1.6 MHz	30 kHz
cdma2000	3.75 MHz	n/a	30 kHz
cdmaOne	1.2288 MHz	n/a	10 kHz
TETRA	24.3 kHz	25 kHz	300 Hz
NADC IS136	25 kHz	30 kHz	1 kHz
PDC	21 kHz	50 kHz	300 Hz

6.2.7.2.2 Measuring the Occupied Bandwidth

Use

An important characteristic of a modulated signal is its occupied bandwidth. In a radio transmission system, for example, the occupied bandwidth must remain within specific limits to ensure unimpaired transmission in adjacent channels. The occupied bandwidth is defined as the bandwidth in which 99% of the entire power of a transmitter is contained.

Measuring occupied bandwidth

1. Set the center frequency according to the nominal channel frequency (➤ 6-73).
2. Set the frequency span so that it is approx. 2 to 3 times larger than the occupied bandwidth to be measured (➤ 6-75).
3. Press the **OCCUPIED BAND-WIDTH** function key in the **CHANNEL POWER** submenu.

First, the total power of all displayed points on the trace is calculated. Next, the measurement points starting from the right-hand edge of the trace are integrated until 0.5 % of the total power is reached. Temporary marker 1 is positioned at the appropriate frequency. The R&S FS315 then integrates correspondingly from the left-hand edge of the trace until 0.5 % of the power is reached. It positions temporary marker 2 at this point. 99 % of the power is thus located between the two markers. The gap between the two frequency markers is the occupied bandwidth. It is shown in the measurement diagram.

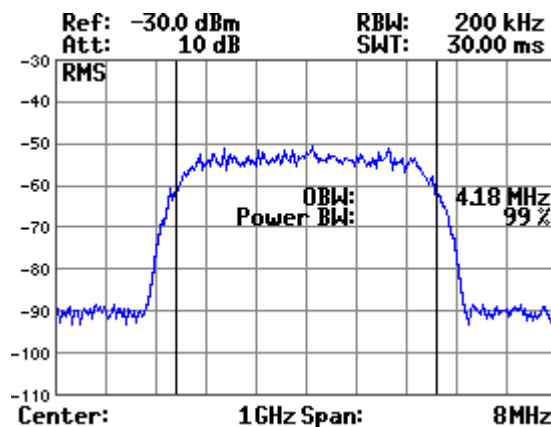

Changing the occupied bandwidth

1. Press the **% POWER BAND-WIDTH** function key in the **CHANNEL POWER** submenu.

An entry field containing the current setting of the limit line is displayed in the top left-hand corner. The default setting is 99 %.

% Power Bandwidth
99 %

2. Enter a new value (➤ 5-57).

The entry range for the bandwidth is:

$$10 \% \leq \text{Power Bandwidth} \leq 100 \%$$

Temporary markers 1 and 2 are repositioned and the gap between the two frequency markers is the new occupied bandwidth. It is shown in the measurement diagram.

6.2.7.3 Configuring the Built-In Generator

What the settings are for

From the TRACKING GEN submenu, you can enter the generator operating mode, the frequency and output level, the frequency offset for frequency-converting measurements and a level offset. The configuration options for the generator differ depending on the selected operating mode.

- **Tracking Generator:**

The output frequency of the generator runs in synchronism with the analyzer (tracking generator mode). This operating mode can be used to determine the transmission characteristics of a DUT. The setting parameters are:

LEVEL, FREQ OFFSET, CAL TRANSMISSION, REF POSITION, REF OFFSET

- **Fixed Frequency:**

The output frequency of the generator is fixed and can be set manually within the permissible limits. In this operating mode, the internal generator substitutes an external CW signal source that is often required for various measurements. The setting parameters are:

LEVEL, FREQ

Selecting the TRACKING GEN submenu

- Press the  function key in the  menu.

The submenu opens and the appropriate functions are assigned to the function keys [13].

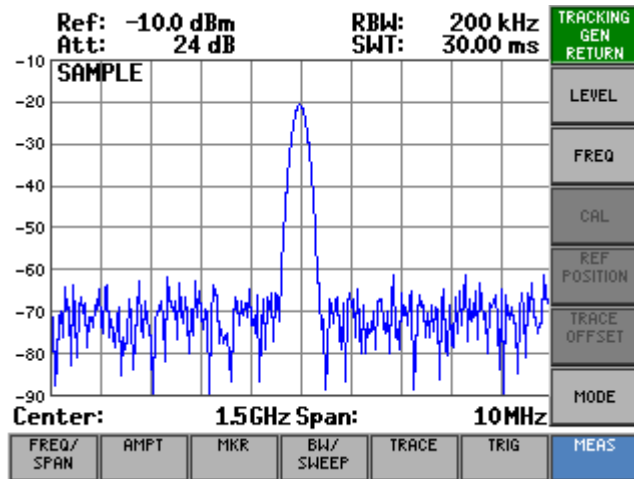

Function key assignment



Quitting the submenu



Enter the output level

(↗ 6-159)



Enter the frequency or enter the frequency offset (Tracking Generator)

(↗ 6-159)

(↗ 6-154)



Calibrate the test setup and activate the calibration

(↗ 6-154)



Enter the reference position

(↗ 6-154)



Enter the level offset

(↗ 6-154)





Select the tracking generator operating mode

(↗ 6-154)



Note

The ,  and  function keys are only available if the calibration is activated.

The “Tracking Generator” operating mode is not available in zero-span mode.

6.2.7.3.1 Selecting the Operating Mode

 Note

The “Tracking Generator” operating mode is not available in zero-span mode.

Use

The generator is switched off when in its initial state. You can select two different operating modes:

- **Tracking Generator**
The generator operates at the same frequency as the analyzer.
- **Freq Fixed**
The generator operates at a fixed frequency irrespective of the analyzer frequency.

Selecting operating mode

1. Press the  function key in the  submenu.

A selection field containing the available settings is displayed. The default setting is off.



2. Select a operating mode with **rotary knob** [11].
3. Press the **ENTER key** [5] to close the selection field.

The generator is switched on and a signal is applied at the output [9]. The level and frequency of the generator are displayed in the measurement diagram (e.g. “Freq Fixed” operating mode).

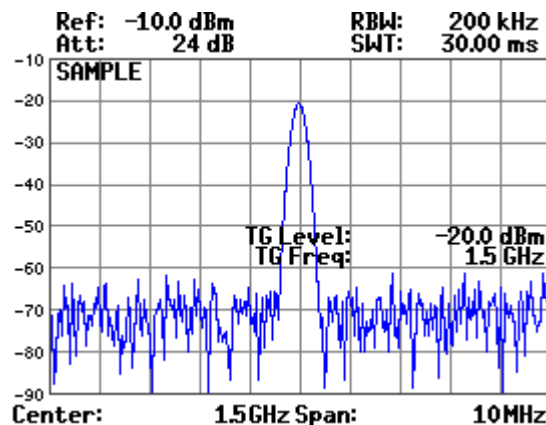

6.2.7.3.2 “Tracking Generator” Mode

Use

In “Tracking” mode, the generator runs at the same frequency as the spectrum analyzer. Measurement can be performed either uncalibrated in absolute levels or calibrated referred to a measured trace.

By using an external bridge (e.g. R&S), you can determine in this mode the percentage of power that is reflected by a test port.



You can freely select a frequency offset to allow frequency-converting DUTs to be measured.

Performing transmission measurement

The transmission measurement measures the transmission characteristics of a twoport. The built-in tracking generator is used as the signal source. It is connected to the input connector of the DUT. The input of the R&S FS315 is supplied from the output of the DUT.

Calibration can be performed in order to compensate the effects caused by the test setup (e.g. frequency response of the connecting cables) during the transmission measurement.

Note: If a calibration is not desired, steps 1 and 6 can be omitted.

1. Connect the output of the tracking generator [9] directly to the input of the spectrum analyzer [8] (measurement cable without DUT).
2. Select the center frequency (↗ 6-73) and frequency span (↗ 6-75).
3. Select the "Tracking" mode (↗ 6-154).
4. If necessary, adjust the output level of the tracking generator (↗ 6-159). Make sure that the permissible input power of your DUT is not exceeded.
5. With active DUTs, make sure that the sum of tracking generator output level plus amplifier gain does not exceed the selected reference level of the spectrum analyzer. If necessary, adjust the reference level (↗ 6-84).
6. Press the  function key in the  submenu.

A frequency sweep which plots a reference trace is started. This trace together with the used instrument setup is saved and is used to form the difference with respect to the current measurement values. When the reference measurement has been completed, the trace is normalized automatically and displayed in the diagram area.

7. Connect the DUT (e.g. bandpass) in the test setup and perform the transmission measurement.

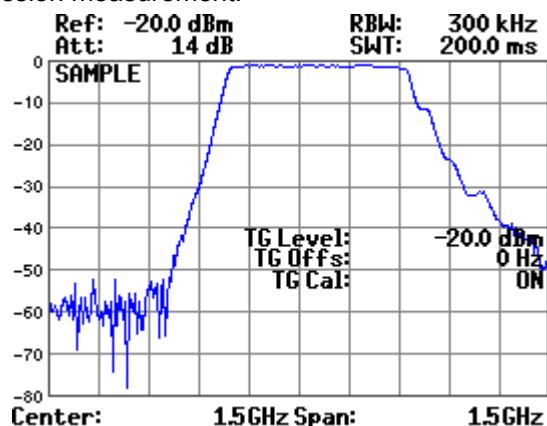

Performing reflection measurement

The reflection measurement is used to determine the percentage of power versus frequency that is reflected by a DUT port. An external bridge that is connected between the tracking generator output and the analyzer input is necessary for the measurement. The reflected power is displayed as return loss in dB.

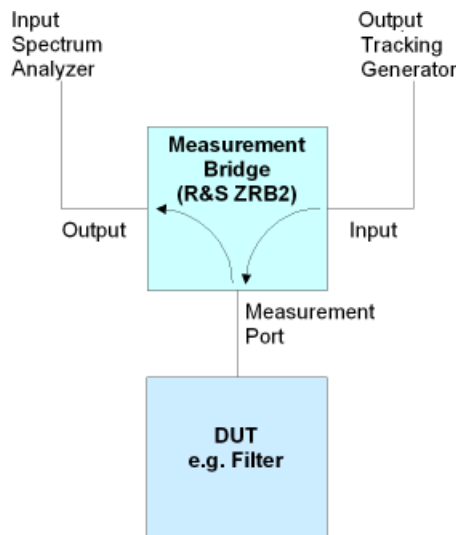

The test setup must be calibrated in order to take losses of the bridge into account.

1. Connect the bridge between the output of the tracking generator [9] and the input of the spectrum analyzer [8]. For calibrating the test setup, the test port of the bridge must be terminated with either an open or a short calibration standard.
2. Select the center frequency (↗ 6-73) and frequency span (↗ 6-75).
3. Select the "Tracking" mode (↗ 6-154).
4. If necessary, adjust the output level of the tracking generator (↗ 6-159).
5. Press the **CAL** function key in the **TRACKING GENER** submenu.
6. Connect the DUT (e.g. filter) in the test setup and perform the transmission measurement.

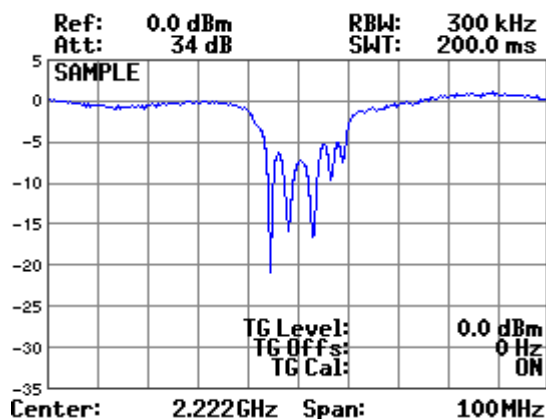

Entering frequency offset

1. Press the **FREQ** function key in the **TRACKING GENER** submenu.

An entry field containing the current setting of the limit line is displayed in the top left-hand corner. The default setting is 0 Hz.

TG Freq Offset
0 Hz

2. Enter a new value (↗ 5-57).

The entry range for the frequency offset is:

$$0 \text{ Hz} \leq \text{TG Freq Offset} \leq 3 \text{ GHz}$$

The new setting is saved and displayed in the diagram area. The tracking generator is switched on.

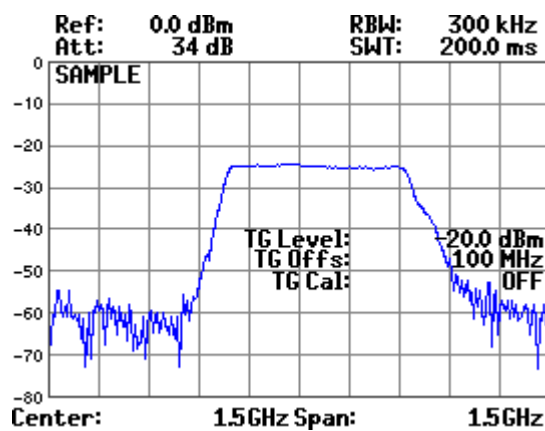

The output frequency of the tracking generator is calculated as follows:

$$\text{TG frequency} = \text{Receive frequency} + \text{Frequency offset}$$

Note

The display shows a red dot next to the TG CAL sign in the measurement diagram if any of the following parameters is changed after the calibration:

- center frequency
- span
- reference level
- resolution bandwidth
- sweep time

The red dot visualizes that the calibration conditions are not valid for the current measurement. It vanishes when the instrument is recalibrated with the new parameters.

Setting reference position

To display the gain of active components, you must shift the reference position of the trace.

1. Press the **REF POSITION** function key in the **TRACKING GENER** submenu.

An entry field containing the current setting of the limit line is displayed in the top left-hand corner. The default setting is 100 %.

TG Ref. Position 100 %

2. Enter a new value (↗ 5-57).

The entry range for the referency position is:

$$0 \% \leq \text{TG Ref. Position} \leq 100 \%$$

The new setting is saved and adopted in the diagram area. The tracking generator is switched on.

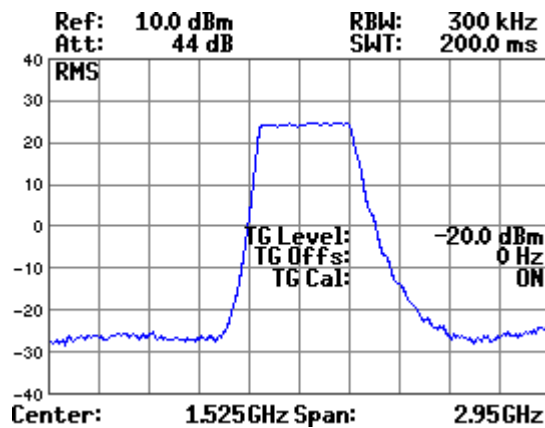

Setting level offset

If the level offset of the test setup is known, you can take this into account by entering a level offset.

1. Press the **TRACE OFFSET** function key in the **TRACKING GENER** submenu.

An entry field containing the current setting of the limit line is displayed in the top left-hand corner. The default setting is 0 dB.

TG Trace Offset 0.0 dB

2. Enter a new value (↗ 5-57).

The entry range for the frequency offset is:

$$-100 \text{ dB} \leq \text{TG Trace Offset} \leq 50 \text{ dB}$$

The new setting is saved and adopted in the diagram area. The tracking generator is switched on.

6.2.7.3.3 “Freq Fixed” Mode

Use

In “Freq Fixed” mode, the generator operates independently of the spectrum analyzer. You can freely select the frequency and level of the generator.

Entering the level

1. Press the **LEVEL** function key in the **TRACKING GENER** submenu.

An entry field containing the current setting of the limit line is displayed in the top left-hand corner. The default setting is -20 dBm.

TG Level
-20.0 dB

2. Enter a new value in 0.1 dB steps (↗ 5-57).

The entry range for the output level is:

$$-50 \text{ [dBm]} \leq \text{TG Level} \leq +0 \text{ [dBm]}$$

The new setting is saved and displayed in the diagram area (↗ below).

Entering the frequency

1. Selecting the operating mode “Freq Fixed“ (↗ 6-154).
2. Press the **FREQ** function key in the **TRACKING GENER** submenu.

An entry field containing the current setting of the limit line is displayed in the top left-hand corner. The default setting is 0 Hz.

TG Freq Fixed
0 Hz

3. Enter a new value (↗ 5-57).

The entry range for the frequency is:

$$0 \text{ Hz} \leq \text{TG Freq Fixed} \leq 3 \text{ GHz}$$

The new setting is saved and displayed in the diagram area. The generator is switched on.

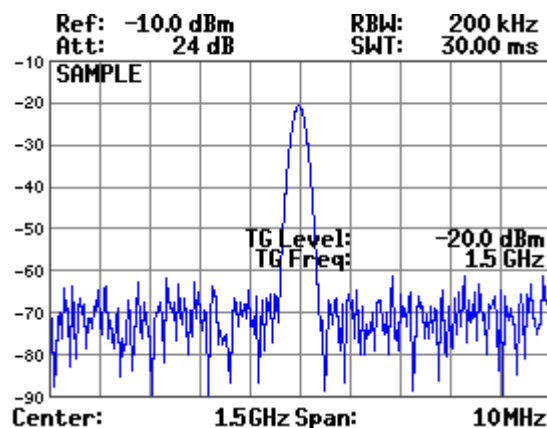



6.2.7.4 AM/FM Demodulation

What the settings are for

From the DEMOD submenu, you can demodulate AM or FM signals and identify them using connected headphones.



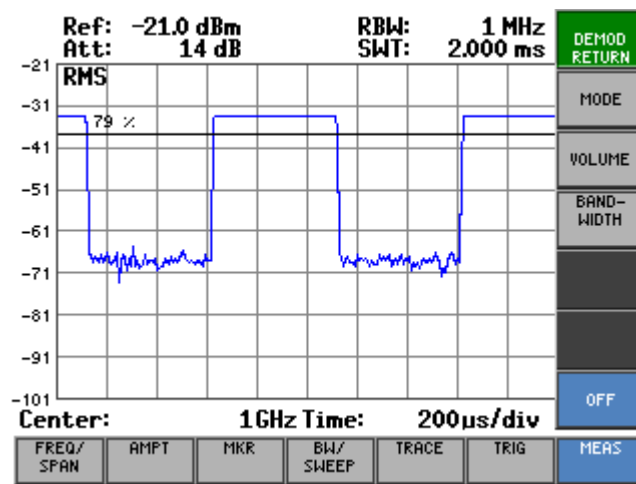

Selecting the DEMOD submenu

1. Switch the R&S FS315 to the time-domain mode (ZERO SPAN, ↗ 6-75).
2. Press the  function key in the  menu.

The submenu opens and the appropriate functions are assigned to the function keys [13].



Function key assignment

	Quitting the submenu	
	Select the AM/FM demodulation mode	(↗ 6-161)
	Adjust the headphone volume	(↗ 6-161)
	Set the demodulation bandwidth	(↗ 6-161)
	Switching off the AM/FM demodulation	(↗ 6-161)

6.2.7.4.1 Demodulating Signals

Use

You can use the AM/FM demodulator of the R&S FS315 to demodulate the input signal (AM, FM) and to monitor it using headphones connected to the socket [25].

You can limit the signal bandwidth of the signal to be demodulated by selecting a resolution bandwidth.

Setting demodulation mode

1. Press the **MODE** function key in the **DEMOD** submenu.

A selection field containing the available settings is displayed. The default setting is AM.

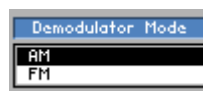

2. Select a demodulation mode with **rotary knob** [11].
3. Press the **ENTER** key [5] to close the selection field.

The new setting is saved and the selected demodulation mode is activated.

Adjusting monitoring volume

1. Press the **VOLUME** function key in the **DEMOD** submenu.

An entry field containing the current setting of the limit line is displayed in the top left-hand corner. The default setting is 0.0 %.

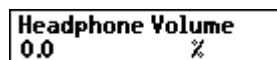

2. Enter a new value (↻ 5-57).

The entry range for the headphone volume is:

$$0 \% \leq \text{Headphone Volume} \leq 100 \%$$

The new setting is saved and the monitoring volume of the AM/FM demodulator is set to the new value.

Setting filter bandwidth

1. Press the **BAND-WIDTH** function key in the **DEMOD** submenu.

A selection field containing the available settings is displayed. The selected resolution bandwidth is adopted (e.g. 1 MHz).

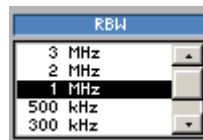

2. Select a filter bandwidth with **rotary knob** [11].
 3. Press the **ENTER** key [5] to close the selection field.
- The new setting is saved and the selected filter bandwidth is set.

Switching off demodulation

- Press the **OFF** function key in the **DEMOD** submenu.

The AM/FM demodulator is switched off.

6.2.7.5 Measuring the Third-Order Intercept Point

Use

If two signals with different frequencies are applied to a DUT with non-linear characteristic, intermodulation products occur at the output. Third-order mixture products are of particular importance since they are close to the useful signals.

The frequencies of the noise products f_{s1} and f_{s2} are located above and below the frequencies of the input signals f_{n1} and f_{n2} :

$$F_{s1} = 2 \times f_{n1} - f_{n2}$$

$$F_{s2} = 2 \times f_{n2} - f_{n1}$$

A third-order intercept point can be easily calculated with the input signals at the same level P_n plus the measured value of an intermodulation product:

$$IP3 = a_{d3}/2 + P_n$$

- where: IP3: Third-order intercept point (=TOI)
 a_{d3} : Level difference (in dB) between the input signal and a third-order intermodulation product
 P_n : Level of the input signal

When the TOI function is activated, the R&S FS315 detects a two-tone signal at the input and uses the signal frequencies to calculate the position of the intermodulation products. Marker 1 is automatically placed on the largest input signal. Marker 2 is placed on the larger of the two intermodulation products and the third-order intercept point is calculated from the difference in level between the input signal and the intermodulation product.

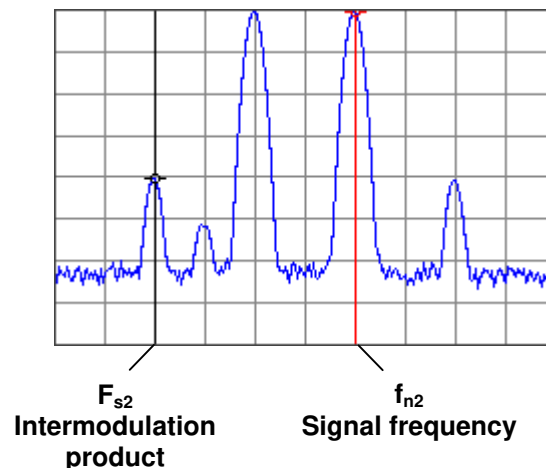

Activating the measurement

1. Adjust the **frequency span** (↗ 6-75).
The intercept point can only be calculated correctly if the input signals have approximately the same level (± 1.5 dB) and the intermodulation products are within the selected frequency span.
2. Adjust the **reference level** (↗ 6-84).
To prevent the spectrum analyzer overload from being measured, make sure that the input levels are not higher than the selected reference level.

3. Press the **TOI** function key in the **MEAS** submenu.

The TOI measurement is activated and the function key is highlighted. The value calculated for the TOI is displayed in the parameter field.

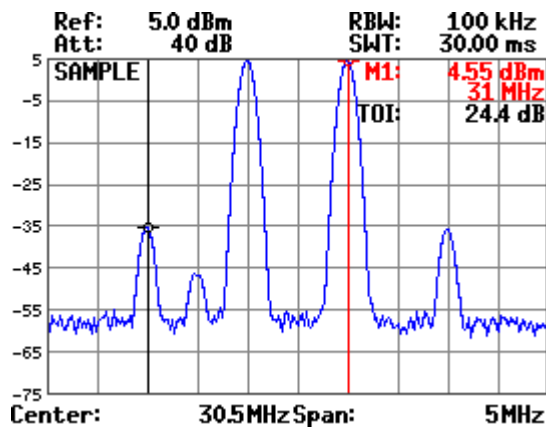

Deactivating the measurement

- Press the **TOI** function key in the **MEAS** submenu.

The TOI measurement is deactivated and the function key is no longer highlighted.

6.2.7.6 Activating the Transducer Function

What the settings are for

From the TRANSDUCER submenu, you can load, save, activate or deactivate transducer sets created using the PC software R&S FS315-K1 (↗ 7-258).





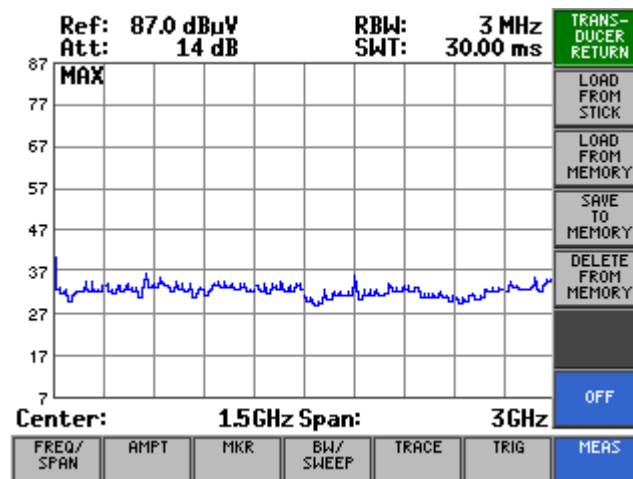

Selecting the TRANSDUCER submenu

- Press the  function key in the  menu.

The submenu opens and the appropriate functions are assigned to the function keys [13].



Function key assignment

	Quitting the submenu	
	Load a transducer set from a USB stick	(↗ 6-165)
	Load a transducer set from the internal memory	(↗ 6-165)
	Save a transducer set to the internal memory	(↗ 6-165)
	Delete a transducer set from the internal memory	(↗ 6-165)
	Deactivate a transducer set	(↗ 6-165)

6.2.7.6.1 Using Transducer Sets

Use

You can load a transducer set from a USB stick to the R&S FS315 and save it in the internal memory. To do this, you must connect the USB stick to the USB device connector [17] at the rear of the instrument. After you have selected and loaded a transducer set, it becomes active and the transducer function is switched on. You can create transducer sets using the PC software R&S FS315-K1 (↗ 7-258).

During the sweep, the values from the active transducer set are added to the result of the level measurement. The correction values are recalculated if the sweep range is changed. If an activated transducer set is not defined across the entire sweep range for the measurement, the missing values are replaced by zero.

The selected level unit is determined by the transducer set and cannot be changed in the AMPT menu.

Loading and activating transducer set from USB stick

1. Press the **LOAD FROM STICK** function key in the **TRANS-DUCER** submenu.

A selection field containing the available transducer sets is displayed.

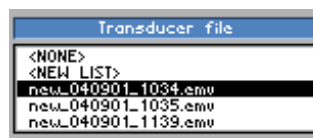

2. Select a transducer set with **rotary knob** [11].
3. Press the **ENTER key** [5] to close the selection field.

The transducer set is loaded and activated.

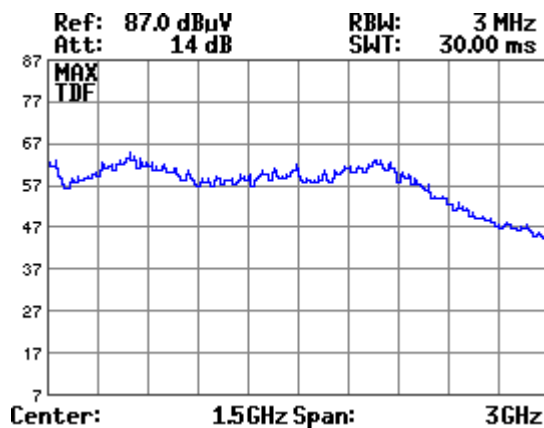

Loading and activating transducer set from internal memory

1. Press the **LOAD FROM MEMORY** function key in the **TRANS-DUCER** submenu.

A selection field containing the available transducer sets is displayed.

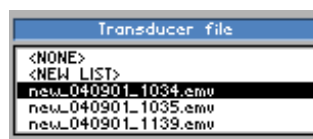

2. Select a transducer set with **rotary knob** [11].
3. Press the **ENTER key** [5] to close the selection field.
The transducer set is loaded and activated (↗ above).

Saving transducer set to internal memory

1. Press the  function key in the  submenu.

A selection field containing the available transducer sets on the USB stick is displayed.

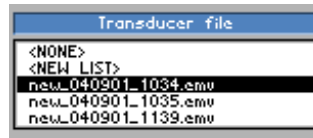

2. Select a transducer set with **rotary knob** [11].
3. Press the **ENTER key** [5] to close the selection field.
The transducer set is saved to the internal memory.

Deactivating active transducer set

- Press the  function key in the  submenu.

The active transducer set is deactivated and the correction values are no longer taken into consideration in traces.

Deleting transducer set from internal memory

1. Press the  function key in the  submenu.

A selection field containing the available transducer sets is displayed.

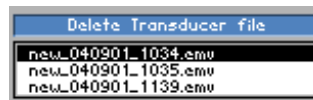

2. Select a transducer set with **rotary knob** [11].
3. Press the **ENTER key** [5] to close the selection field.
The transducer set is deleted.

6.3 SYSTEM Functions (BACK/SYS Key)

Introduction

The R&S FS315 has system and service functions as well as measurement functions.

All current settings can be called so that they can be viewed at a glance, and saved for use at a later date, a selftest can be run on the R&S FS315 and the system settings configured. Furthermore, the R&S FS315 switched over from remote control to local mode.

Switching over the user interface

When the R&S FS315 has been switched on and the selftest has run without detecting any faults, the spectrum analyzer's user interface is activated.

1. Press the **BACK/SYS key** [3].

The measurement diagram and the parameter field are blanked out. The menus for the system and service functions are brought up on the screen in the menu area and the appropriate functions are assigned to the function keys [13]. Depending on the function key assignment, the associated parameters are listed as tables in the diagram area.

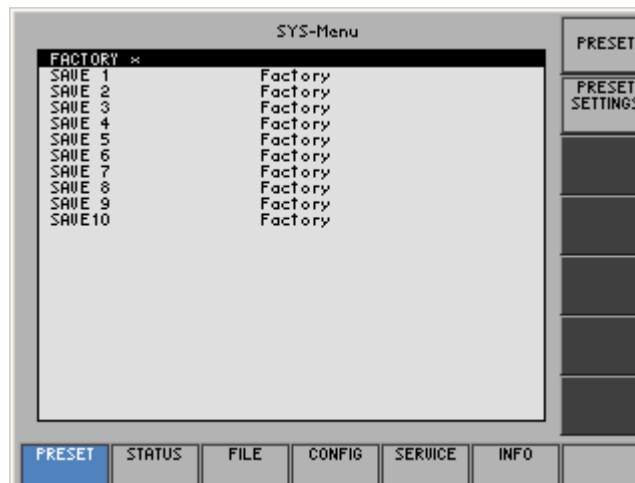







2. Press the **BACK/SYS key** [3].

The **new** settings are saved and the spectrum analyzer's user interface is activated again.

Press the **ESC/CANCEL key** [4].

The **old** settings are retained and the spectrum analyzer's user interface is activated again.

**Menus for
system and
service functions**

	Selects and calls the instrument's default setting	(↗ 6-169)
	Displays the current instrument settings	(↗ 6-171)
	Saves and loads user-defined settings	(↗ 6-177)
	System settings	(↗ 6-184)
	Service functions	(↗ 6-194)
	System information	(↗ 6-195)

6.3.1 Instrument Default Setting (Menu PRESET)

What the settings are for

From the PRESET menu, you can specify a user-defined instrument setting as the instrument default setting and directly call it.

Selecting the PRESET menu

1. Press the **BACK/SYS key** [3].
2. Select the menu  with the **◀** or **▶** cursor key [6].

The menu name is highlighted and the appropriate functions are assigned to the function keys [13].



Function key assignment



Calls an instrument default setting

(↗ 6-170)



Selects an instrument default setting

(↗ 6-170)

6.3.1.1 Selecting and Calling the Instrument Default Setting

Use When you switch on the R&S FS315, those settings that were valid when the R&S FS315 was last switched off are restored.

The R&S FS315 also lets you save and call user-defined instrument settings. If you frequently use one of these settings and want to load it quickly, you can define this setting to be the PRESET (default setting) and call it directly at any time.

Selecting user-defined settings

1. Save the user-defined settings (↗ 6-178).
2. Select the **menu**  with the ◀ or ▶ **cursor key** [6].

A table containing the available settings is displayed. The current setting is marked with the sign x.



FACTORY x	
SAVE 1	Factory
SAVE 2	Factory
SAVE 3	Factory
SAVE 4	Factory
SAVE 5	user saved; 09.01.2005 12:00
SAVE 6	Factory
SAVE 7	Factory
SAVE 8	Factory
SAVE 9	Factory
SAVE 10	Factory

3. Select a setting with the ▲ or ▼ **cursor key** [7].
The selected option is highlighted.
The PRESET memory location FACTORY contains the factory setting (↗ 6-70).

FACTORY x	
SAVE 1	Factory
SAVE 2	Factory
SAVE 3	Factory
SAVE 4	Factory
SAVE 5	user saved; 09.01.2005 12:00
SAVE 6	Factory
SAVE 7	Factory
SAVE 8	Factory
SAVE 9	Factory
SAVE 10	Factory

4. Press the **function key** .
The setting is defined to be the instrument default setting and is marked with the sign x.

Activating the instrument default setting

5. Press the  **function key** in the  **menu**.
The current instrument default setting is loaded and the SYS menu is leaved. The spectrum analyzer's user interface is activated again.

Note

If no user-defined settings have been defined, the PRESET function key  is assigned the FACTORY PRESET, e.g. the factory default setting (↗ 6-70).

6.3.2.1 Spectrum Analyzer Settings

Application

If you wish to see all the spectrum analyzer settings at a glance, you can have the parameters clearly displayed for you together with their current settings.

Displaying settings

- In the **ANALYZER** menu press the **STATUS** function key.

All the parameters are listed in a table showing their current settings.

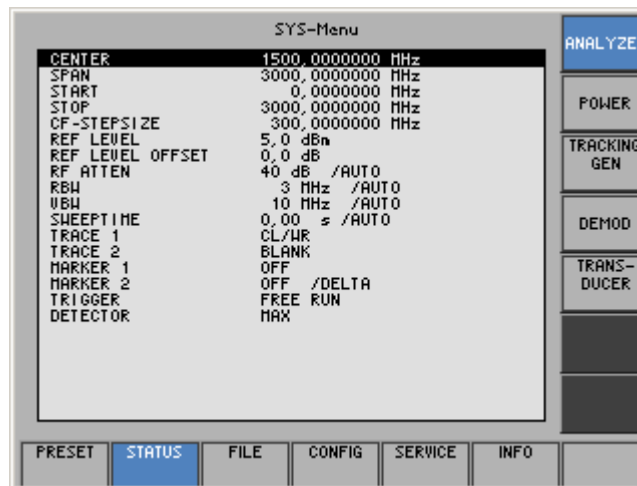

Explanation of parameters

CENTER	Center frequency	(↗ 6-73)
SPAN	Frequency span	(↗ 6-73)
START	Start frequency for span	(↗ 6-79)
STOP	Stop frequency for span	(↗ 6-79)
CF-STEPSIZE	Entering the step width of the center frequency	(↗ 6-80)
REF LEVEL	Reference level	(↗ 6-84)
REF LEVEL OFFSET	Reference level offset	(↗ 6-85)
RF ATTEN	RF input attenuation	(↗ 6-89)
RBW	Resolution bandwidth	(↗ 6-119)
VBW	Video bandwidth	(↗ 6-120)
SWEPTIME	Sweep time	(↗ 6-124)
TRACE 1	Display mode for Trace 1	(↗ 6-132)
TRACE 2	Display mode for Trace 2	(↗ 6-132)
MARKER 1	Marker 1 display	(↗ 6-94)
MARKER 2	Marker 2 display	(↗ 6-98)
TRIGGER	Trigger source	(↗ 6-140)
DETECTOR	Detector	(↗ 6-129)

6.3.2.2 Settings for the Channel Power Measurement

Application

If you wish to see all settings for measuring the channel power at a glance, you can have the parameters clearly displayed for you together with their current settings.

Displaying settings

- In the **POWER** menu press the **STATUS** function key.

All the parameters are listed in a table showing their current settings.

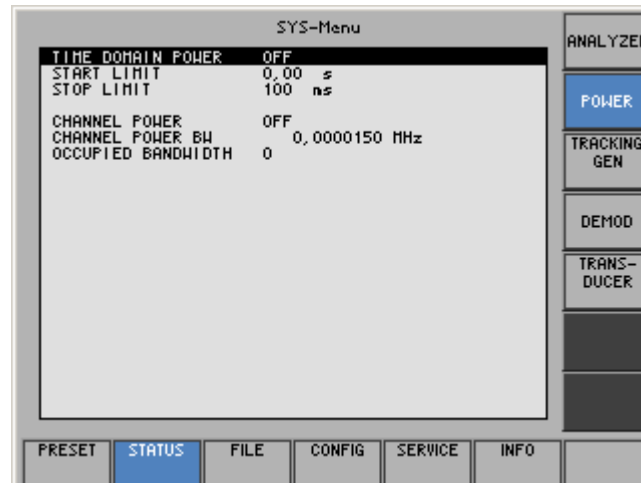

Explanation of parameters

TIME DOMAIN POWER	Status of power measurement in the time domain	(↗ 6-145)
START LIMIT	Lower (left) limit of the time domain	(↗ 6-145)
STOP LIMIT	Upper (right) limit of the time domain	(↗ 6-145)
CHANNEL POWER	Status of channel power in the frequency domain	(↗ 6-149)
CHANNEL POWER BW	Selected channel bandwidth	(↗ 6-149)
OCCUPIED BANDWIDTH	Occupied bandwidth	(↗ 6-151)

6.3.2.3 Tracking Generator Settings

Application If you wish to see all the tracking generator settings at a glance, you can have the parameters clearly displayed for you together with their current settings.

Displaying settings

- In the **STATUS** menu press the **TRACKING GEN** function key.

All the parameters are listed in a table showing their current settings.

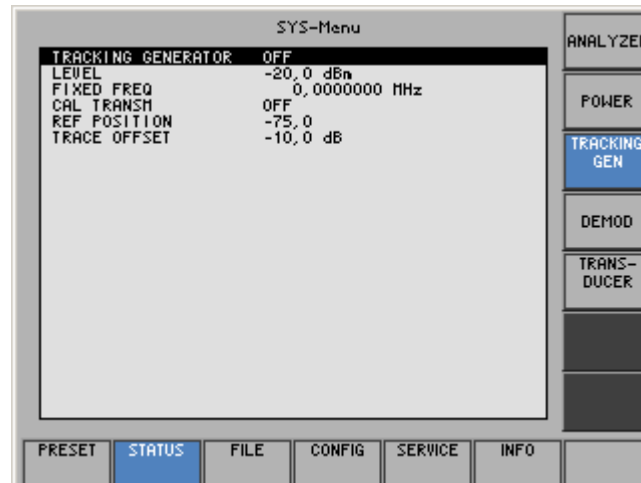

Explanation of parameters

TRACKING GENERATOR	Tracking generator mode	(↗ 6-154)
LEVEL	TG output level	(↗ 6-159)
FIXED FREQ	TG frequency in Freq Fixed mode	(↗ 6-159)
CAL TRANSM	Status of calibration in Tracking Generator mode	(↗ 6-154)
REF POSITION	Reference position in Tracking Generator mode	(↗ 6-154)
TRACE OFFSET	Level offset in Tracking Generator mode	(↗ 6-154)

6.3.2.4 Demodulation Settings

Application

If you wish to see all the settings for demodulation at a glance, you can have the parameters clearly displayed for you together with their current settings.

Displaying settings

- In the **DEMOM** menu press the **STATUS** function key.

All the parameters are listed in a table showing their current settings.

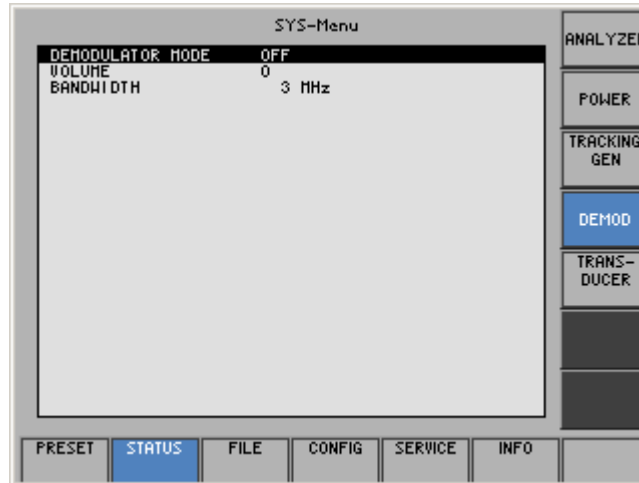

Explanation of parameters

DEMODULATOR MODE	AM/FM demodulation mode	(↗ 6-161)
VOLUME	Headphone volume	(↗ 6-161)
BANDWIDTH	Demodulation bandwidth	(↗ 6-161)

6.3.2.5 Settings for Transducer Sets

Application If you wish to see all settings for transducer sets at a glance, you can have the parameters clearly displayed for you together with their current settings.

Displaying settings

- In the **TRANS-DUCER** menu press the **STATUS** function key.

All the parameters are listed in a table showing their current settings.

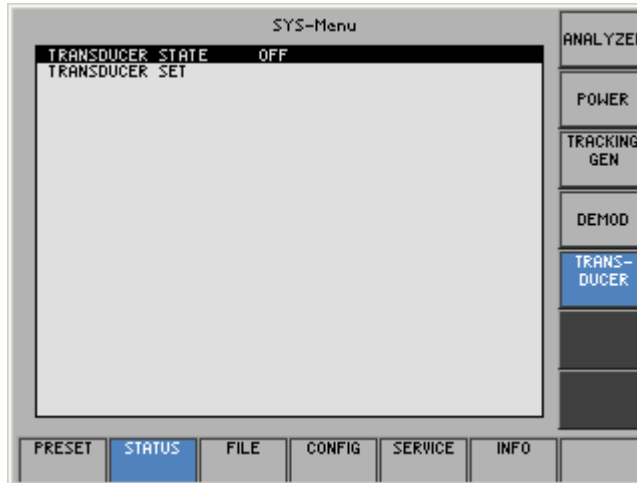

Explanation of parameters

TRANS-DUCER STATE	State of the transducer list	(↗ 6-165)
TRANS-DUCER SET	Transducer list setting	(↗ 6-165)

6.3.3 User-Defined Settings (FILE Menu)

What the settings are for

You can save user-defined settings and load them when required from the FILE menu. You can also print out a screenshot.



Selecting the FILE menu

1. Press the **BACK/SYS key** [3].
2. Select the **FILE** menu with the **◀** or **▶** cursor key [6].

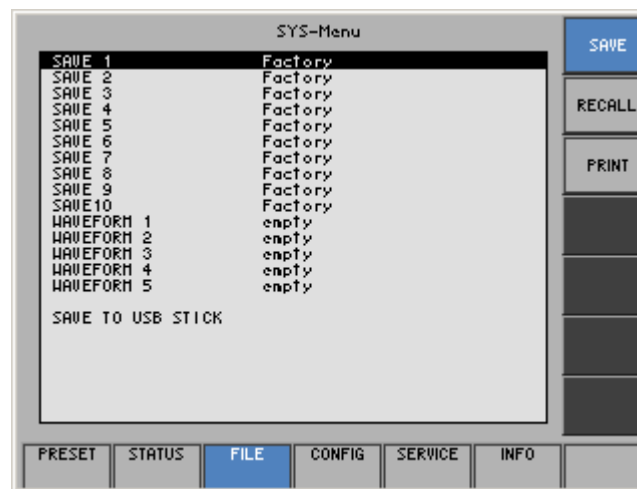
The menu name is highlighted and the appropriate functions are assigned to the function keys [13].



Function key assignment

	Saves a user-defined setting	(↗ 6-178)
	Loads a user-defined setting	(↗ 6-178)
	Prints out a screenshot	(↗ 6-180)

6.3.3.1 Saving and Loading User-Defined Settings

Use When you switch on the R&S FS315, those settings that were valid when the R&S FS315 was last switched off are restored.

The R&S FS315 also lets you save and load user-defined settings.

You can save 10 different settings (SAVE 1 to 10) and 5 traces (WAVE 1 to 5). When the R&S FS315 is delivered, the factory settings are loaded in the SAVE memory locations. The WAVE memory locations are empty.

Saving user-defined settings

1. Set up the R&S FS315 for the measurement you want to perform (➤ 6-70).
2. Connect the USB stick to the **USB connector DEV** [17] if the USB stick is where the settings are to be saved.

3. Press the **SAVE** function key in the **FILE** menu.

A table containing the available settings is displayed (memory locations).

SAVE 1	Factory
SAVE 2	Factory
SAVE 3	Factory
SAVE 4	Factory
SAVE 5	Factory
SAVE 6	Factory
SAVE 7	Factory
SAVE 8	Factory
SAVE 9	Factory
SAVE 10	Factory
WAVEFORM 1	empty
WAVEFORM 2	empty
WAVEFORM 3	empty
WAVEFORM 4	empty
WAVEFORM 5	empty
SAVE TO USB STICK	

4. Select a setting with the **▲** or **▼** cursor key [7].

The selected option is highlighted.

5. Press the **ENTER** key [5].

An entry field for entering a file name is displayed. The default setting is “user saved” or “empty”.

SAVE 5	<input type="text" value="user saved"/>
--------	---

6. Enter a new file name from the **numerical keys** [12] or from an external keyboard (➤ 3-41).

7. Press the **ENTER** key [5].

The current setting is saved and the text “Factory” is replaced by the file name, the date and time.

SAVE 1	Factory
SAVE 2	Factory
SAVE 3	Factory
SAVE 4	Factory
SAVE 5	user saved; 09.01.2005 08:50
SAVE 6	Factory
SAVE 7	Factory
SAVE 8	Factory
SAVE 9	Factory
SAVE 10	Factory
WAVEFORM 1	empty
WAVEFORM 2	empty
WAVEFORM 3	empty
WAVEFORM 4	empty
WAVEFORM 5	empty
SAVE TO USB STICK	

Loading user-defined settings

1. Connect the USB stick to the **USB connector DEV** [17] if the USB stick is where the settings are saved.
2. Press the **RECALL** function key in the **FILE** menu.

A table containing the available settings is displayed (memory locations).

SAVE 1	Factory
SAVE 2	Factory
SAVE 3	Factory
SAVE 4	Factory
SAVE 5	user saved; 09.01.2005 08:50
SAVE 6	Factory
SAVE 7	Factory
SAVE 8	Factory
SAVE 9	Factory
SAVE10	Factory
WAVEFORM 1	empty
WAVEFORM 2	empty
WAVEFORM 3	empty
WAVEFORM 4	empty
WAVEFORM 5	empty

RECALL FROM USB STICK

3. Select a setting with the **▲** or **▼** cursor key [7].
The FACTORY memory location contains the factory setting (↗ 6-70).

SAVE 1	Factory
SAVE 2	Factory
SAVE 3	Factory
SAVE 4	Factory
SAVE 5	user saved; 09.01.2005 08:50
SAVE 6	Factory
SAVE 7	Factory
SAVE 8	Factory
SAVE 9	Factory
SAVE10	Factory
WAVEFORM 1	empty
WAVEFORM 2	empty
WAVEFORM 3	empty
WAVEFORM 4	empty
WAVEFORM 5	empty

SAVE TO USB STICK

4. Press the **ENTER** key [5].
The following message is displayed.

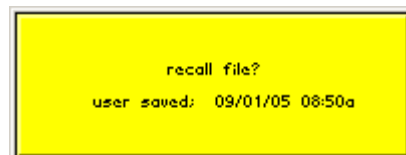

5. Press the **ENTER** key [5].
The setting you have selected is loaded and the SYS menu is leaved. The spectrum analyzer's user interface is activated again.

 **Note**

If you frequently use one of the saved settings and want to load it quickly, you can define this setting to be the PRESET (default setting) and call it directly at any time. (↗ 6-170).

6.3.3.2 Printing out a Screenshot

Use The R&S FS315 prints out (printer) or saves (USB stick) a current screenshot when you press the BACK/SYS key and an overview of the principal current instrument settings. A printer with a USB device connector or a USB stick is required.

Selecting an output unit

1. Press the **PRINT** function key in the **FILE** menu.

A table containing the available parameters is displayed.

2. Select the **PRINTER** parameter with the **▲** or **▼** cursor key [7].

PRINT SCREEN	Press Enter
PRINTER	HP DeskJet mono
ASCII TO USB-STICK	Press Enter

3. Press the **ENTER** key [5].

A selection field containing the available settings is displayed. The default setting is "HP DeskJet mono".

PRINTER
HP DeskJet mono
HP DeskJet color
HP LaserJet III
HP LaserJet IV
HP LaserJet V
USB Stick

4. Select a setting with the **rotary knob** [11].
5. Press the **ENTER** key [5] to close the selection field.

The setting is saved and the printer driver is loaded.

Printing out a screenshot

1. Connect a printer to the **USB connector DEV** [17].
2. Select a printer for the output unit (↗ 6-180).
3. Press the **PRINT** function key in the **FILE** menu.

A table containing the available parameters is displayed.

4. Select the **PRINT SCREEN** parameter with the ▲ or ▼ cursor key [7].

PRINT SCREEN	Press Enter
PRINTER	HP DeskJet mono
ASCII TO USB-STICK	Press Enter

5. Press the **ENTER** key [5].

The following message is displayed.



A current screenshot and an overview of the principal current instrument settings (↗ 6-171) is printed out, e. g.:

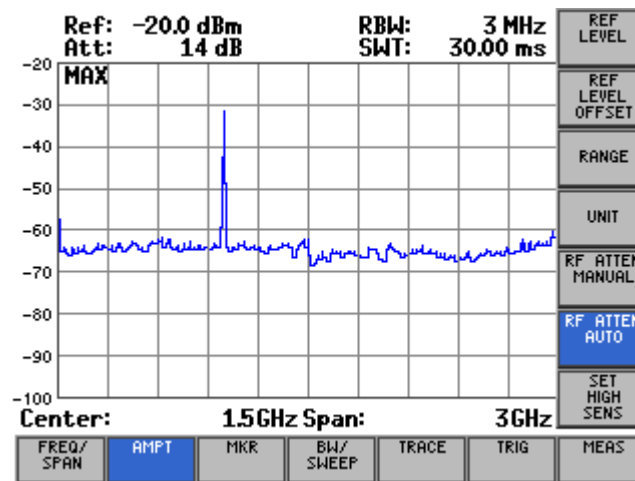

FS315 - Spectrum Analyser

Rohde & Schwarz, Munich

Mon Feb 7 14:35:43 2005

Version 0.40

from 02.02.2005

```

CENTER          1500.000000 MHz
SPAN            3000.000000 MHz
START           0.000000 MHz
STOP            3000.000000 MHz
CF-STEPSIZE     300.000000 MHz
REF LEVEL       -20.0 dBm
REF LEVEL OFFSET 0.0 dB
RF ATTEN        14 dB /AUTO
RBW             3 MHz /AUTO
VBW            10 MHz /AUTO
SWEPTIME        30.0 ms /AUTO
TRACE 1        CL/WK
TRACE 2        BLANK
MARKER 1       OFF
MARKER 2       OFF /NORMAL
TRIGGER        FREE RUN
    
```

Saving the screenshot as a bitmap (.bmp) in the USB stick

1. Connect the USB stick to the **USB connector DEV** [17].
2. Select the USB stick for the output unit (↗ 6-180).
3. Press the **PRINT** function key in the **FILE** menu.

A table containing the available parameters is displayed.

4. Select the **PRINT SCREEN** parameter with the ▲ or ▼ **cursor key** [7].

PRINT SCREEN	Press Enter
PRINTER	HP DeskJet mono
ASCII TO USB-STICK	Press Enter

5. Press the **ENTER key** [5].

An entry field for entering a file name is displayed. The default setting is "FS_Date_Time".



Note: If you wish you can enter a new file name from the **numerical keys** [12] or from an external keyboard (↗ 3-41).

6. Press the **ENTER key** [5].

The current screenshot before you press the BACK/SYS button is saved as a bitmap (.bmp) in the USB stick.



Note

When the USB stick is not connected the following message is displayed:



- Connect the USB stick to the **USB connector DEV** [17] and confirm the message by pressing the **ENTER key** [5].

Saving the waveform data as an ASCII file (.asc) in the USB stick

1. Connect the USB stick to the **USB connector DEV** [17].
2. Press the **PRINT** function key in the **FILE** menu.
A table containing the available parameters is displayed.
3. Select the **ASCII TO USB-STICK** parameter with the **▲** or **▼** cursor key [7].

PRINT SCREEN	Press Enter
PRINTER	HP DeskJet mono
ASCII TO USB-STICK	Press Enter

4. Press the **ENTER** key [5].
An entry field for entering a file name is displayed. The default setting is "FS_Date_Time".

file name

Note: If you wish you can enter a new file name from the **numerical keys** [12] or from an external keyboard (↵ 3-41).

5. Press the **ENTER** key [5].
The current screenshot before you press the BACK/SYS button is saved as an ASCII file (.asc) in the USB stick.



Note

When the USB stick is not connected the following message is displayed:

No Stick!
Please plug usb stick on device.
Confirm Message with ENTER

- Connect the USB stick to the **USB connector DEV** [17] and confirm the message by pressing the **ENTER** key [5].

6.3.4 System Settings (CONFIG Menu)

What the settings are for

You can configure the general system parameters for time/date, reference source, instrument interface and screen saver from the CONFIG menu.

Selecting the CONFIG menu

1. Press the **BACK/SYS key** [3].
2. Select the **CONFIG** menu with the **◀** or **▶** cursor key [6].

The menu name is highlighted and the appropriate functions are assigned to the function keys [13].

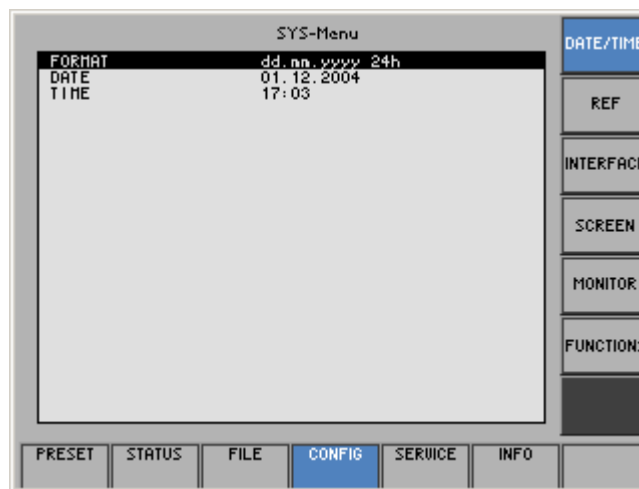

Function key assignment

DATE/TIME	Sets the date and time	(↗ 6-185)
REF	Selects an internal or external reference source	(↗ 6-187)
INTERFACE	Configures the instrument interfaces	(↗ 6-188)
SCREEN	Sets the screen saver mode	(↗ 6-190)
MONITOR	Selects an internal or external monitor	(↗ 6-193)
FUNCTIONS	Enable new functions	

6.3.4.1 Setting the Date and Time of Day

Use

When you save a setting, it is time-stamped using the time provided by the internal real-time clock (➔ 6-178).

When you set the internal real-time clock, you can choose between two date and time display format options and modify the parameters.

- **dd.mm.yyyy** **24 h clock**
- **mm/dd/yyyy** **12 h clock**

where: d - day
 m - month
 y - year

Selecting the display format

1. Press the **DATE/TIME** functions key in the **CONFIG** menu.
 A table containing the available parameters is displayed.
2. Select the **FORMAT** parameter with the **▲** or **▼** cursor key [7].



3. Press the **ENTER** key [5].
 A selection field containing the available settings is displayed. The default setting is "dd.mm.yyyy".

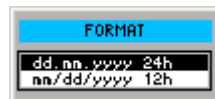

4. Select a setting with the **rotary knob** [11].
5. Press the **ENTER** key [5] to close the selection field.
 The setting is saved and the display format updated.

Setting
the date

1. Press the **DATE/TIME** function key in the **CONFIG** menu.
A table containing the available parameters is displayed.
2. Select the **DATE** parameter with the **▲** or **▼** cursor key [7].

FORMAT	dd. mm. yyyy 24h
DATE	01.12.2004
TIME	17:03

3. Press the **ENTER** key [5].
An entry field containing the current setting is displayed.

Date	01.12.2004
------	------------

4. Enter a new value (↵ 5-57).
5. Press the **ENTER** key [5].
The setting is saved and displayed.

Setting
the time

1. Press the **DATE/TIME** function key in the **CONFIG** menu.
A table listing the available parameters is displayed.
2. Select the **TIME** parameter with the **▲** or **▼** cursor key [7].

FORMAT	dd. mm. yyyy 24h
DATE	01.12.2004
TIME	17:03

3. Press the **ENTER** key [5].
An entry field containing the current setting is displayed.

Time	17:18
------	-------

4. Enter a new value (↵ 5-57).
5. Press the **ENTER** key [5].
The setting is saved and displayed.

6.3.4.2 Selecting an Internal or External Reference Source

Use

The R&S FS315 acting as the frequency standard for all internal oscillators can use the internal reference source (**internal**) or an external reference source (**external**). A 10 MHz crystal oscillator is used as the internal reference source. When the default setting is activated (internal reference), a 10 MHz frequency is output at the REF OUT rear-panel connector [23] to synchronize other devices to the R&S FS315 reference frequency, for example.

When the “REFERENCE external” setting is activated, the REF IN connector [24] is used as the input for an external frequency standard. All the R&S FS315’s internal oscillators are synchronized to this external reference frequency (also 10 MHz).

Selecting the reference source

1. When required, connect the external reference source to the REF IN connector [24].

2. Press the  function key in the  menu.

The current reference source setting is displayed.



3. Press the **ENTER** key [5].

A selection field containing the available settings is displayed. The default setting is “internal”.

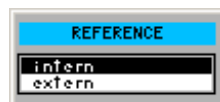

4. Select a reference source with **rotary knob** [11].
5. Press the **ENTER** key [5].

The setting is saved and the R&S FS315 frequency standard is taken from a new source.

Note

If there is no reference signal when you switch over to an external reference, the message PLL UNLOCK is output after a short delay to indicate that there is no sync.

6.3.4.3 Configuring the Instrument Interfaces

Use

The R&S FS315 can be remote-controlled via the existing USB host interface [16]. The R&S FS315 automatically detects an existing connection to a PC and also automatically switches to remote control in the default setting (AUTO).

Switchover between internal USB master (local control on the instrument) and external USB master (remote control via PC) is effected by means of a USB master switch.

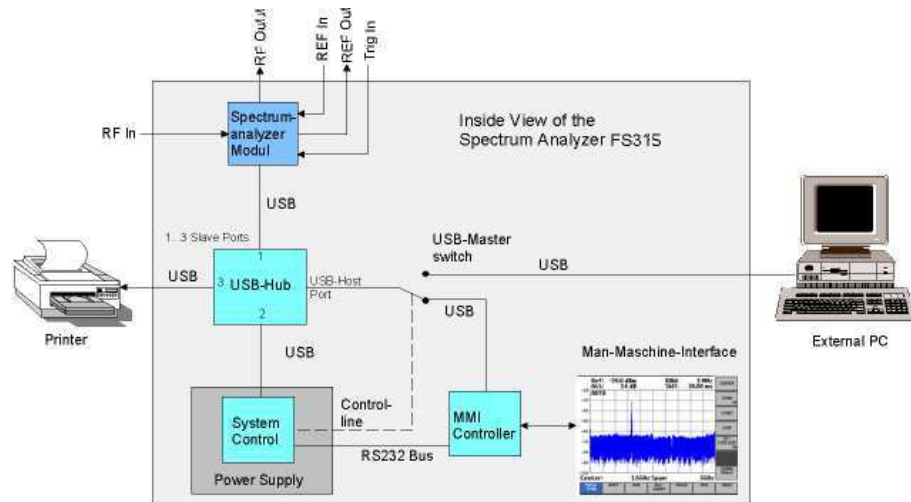

The behaviour of the USB master switch can be controlled via the following settings:

- **AUTO**

The AUTO setting is the standard configuration of the USB master switch and allows flexible switching between the local control mode on the R&S FS315 and remote control via PC. This setting allows the instrument to automatically find a connected PC and switch immediately to “remote control”. Under Windows™, the R&S FS315 is recognized as a new USB device, and is thus available for software applications on the PC.

When you press the BACK/SYS key [3], the R&S FS315 can be switched to “local mode” at any time. The PC and the R&S FS315 are thus physically disconnected. Reactivate the AUTO setting to switch the R&S FS315 again to “remote control”.

- **INSTRUMENT**

The INSTRUMENT setting is required if the R&S FS315 is to be controlled only via the front panel (local control), irrespective of a PC connection. This setting avoids automatic switchover to “remote control”.

When you switch the INSTRUMENT setting to AUTO, an existing PC is recognized, and the R&S FS315 automatically switches to “remote control”.

- **EXTERN**

If EXTERNAL is set, the USB master switch is in the “remote control” mode and the R&S FS315 can only be controlled via a PC.

When you press the BACK/SYS key [3], the R&S FS315 can be switched again to “local mode” at any time, for example for changing settings. Re-activate the EXTERNAL setting to switch the R&S FS315 again to “remote control”.

Setting the USB master selector

1. Press the **INTERFACE** function key in the **CONFIG** menu.
The current USB master setting is displayed.



2. Press the **ENTER** key [5].
A selection field containing the available settings is displayed. The default setting is AUTO.



3. Select a setting with **rotary knob** [11].
4. Press the **ENTER** key [5] to close the selection field.
The setting is saved.



Note

With remote control, the local control mode of the R&S FS315 is deactivated and can only be reactivated by pressing the BACK/SYS key [3] on the front panel. Switching between remote control and local control takes approx. 2 s.

6.3.4.4 Setting the Screen Saver Mode

Activating the screen saver

The R&S FS315 has a screen-saver function that turns off the screen [14] after a certain time. There are a number of timing options for screen turn-off:

- **none**
The screen is always on.
- **5 min**
The screen is turned off after 5 minutes.
- **30 min**
The screen is turned off after 30 minutes.

1. Press the **SCREEN** function key in the **CONFIG** menu.

A table listing the available parameters is displayed.

2. Select the **SCREEN SAVER** parameter with the **▲** or **▼** cursor key [7].

SCREEN SAVER	none
REMOTE	picture
SCREEN COLOR	black

3. Press the **ENTER** key [5].

A selection field containing the available settings is displayed. The default setting is "none".

SCREEN SAVER
none
5 min
30 min

4. Select a setting with **rotary knob** [11].
5. Press the **ENTER** key [5].

The setting is saved and the screen saver is activated or de-activated.

Activating the Screen saver in remote-control mode

If the instrument is in remote-control mode and the results are being displayed on the controller (PC monitor) the screen can be switched off.

- **picture**
The screen displays when the instrument is in remote-control mode.
- **black**
The screen is switched off.

1. Press the **SCREEN** function key in the **CONFIG** menu.

A table listing the available parameters is displayed.

2. Select the **REMOTE** parameter with the **▲** or **▼** cursor key [7].

SCREEN SAUER	none
REMOTE	picture
SCREEN COLOR	black

3. Press the **ENTER** key [5].

A selection field containing the available settings is displayed. The default setting is "black".



4. Select a setting with **rotary knob** [11].

5. Press the **ENTER** key [5].

The setting is saved and the screen disconnection in the remote-control mode is activated or de-activated.

With the "black" setting, the screen is, of course, black, and only the green LED [2] indicates that the R&S FS315 is in remote-control mode.

With the "picture" setting, the following message is displayed on the screen with the R&S FS315 in remote-control mode:

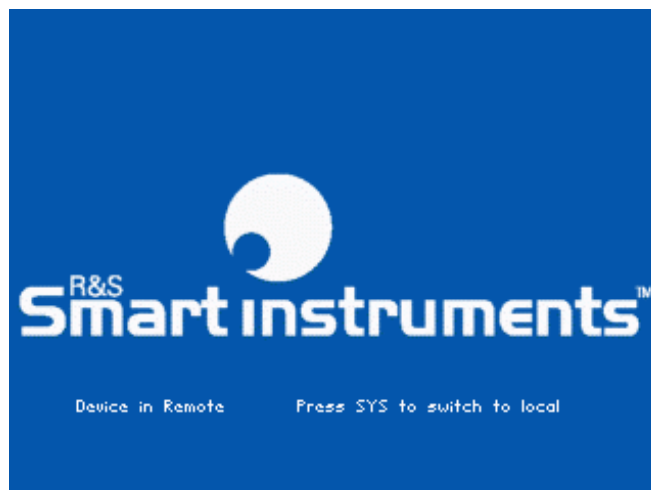

Note

With remote control, the local control mode of the R&S FS315 is deactivated and can only be reactivated by pressing the BACK/SYS key [3] on the front panel. Switching between remote control and local control takes approx. 2 s.

Setting screen background color

You can select the following background colors for the screen [14] of the R&S FS315:

- **black**
The screen background is black.
- **blue**
The screen background is blue.
- **white**
The screen background is white.

1. Press the **SCREEN** function key in the **CONFIG** menu.

A table listing the available parameters is displayed.

2. Select the **SCREEN COLOR** parameter with the **▲** or **▼** cursor key [7].

SCREEN SAVER	none
REMOTE	picture
SCREEN COLOR	blue

3. Press the **ENTER** key [5].

A selection field containing the available settings is displayed. The default setting is blue.

SCREEN COLOR
black
blue
white

4. Select a setting with **rotary knob** [11].

5. Press the **ENTER** key [5].

The setting is saved and the screen background is displayed in the selected color.

6.3.4.5 Selecting an Internal or External Monitor

Use Screen display is possible via the internal monitor or an external monitor.

- **intern**
Screen display is via the built-in colour TFT display.
- **extern**
Screen display is via the connected monitor.

Selecting the monitor

1. If required, connect a monitor to the MONITOR connector [21].
2. Press the **MONITOR** function key in the **CONFIG** menu.
The current screen setting is displayed.



3. Press the **ENTER** key [5].
A selection field containing the available settings is displayed. The default setting is "intern".



4. Select a setting with **rotary knob** [11].
5. Press the **ENTER** key [5].
The setting is saved.
If the "external" setting is selected, the connected screen shows the active user interface. The internal monitor is switched off.

6.3.5 Service Functions (SERVICE Menu)

What the settings are for

You can call a number of auxiliary functions to be used for servicing or troubleshooting from the SERVICE menu. These functions are not required for normal measurements with the R&S FS315.

Selecting the SERVICE menu

1. Press the **BACK/SYS key** [3].
2. Select the **SERVICE** menu with the **◀** or **▶** cursor key [6].

The menu name is highlighted and the appropriate functions are assigned to the function keys [13].



Function key assignment



Performs a selftest

(↗ 6-194)

6.3.5.1 Performing Selftests

Use

The R&S FS315 can perform a module selftest. If there is a fault, the R&S FS315 itself is capable of localizing the defective module.

Starting selftests

1. Press the **SELFTEST** function key in the **SERVICE** menu.

The text SELFTEST is displayed (↗ below).

2. Press the **ENTER key** [5].

The selftest starts. All modules are checked one after the other and the result, "passed" or "failed", is output.

6.3.6 System Information (INFO Menu)

What the settings are for

You can obtain information such as module data, instrument statistics and system messages from the INFO menu.



Selecting the INFO menu

1. Press the **BACK/SYS key** [3].
2. Select the  menu with the **◀** or **▶** **cursor key** [6].

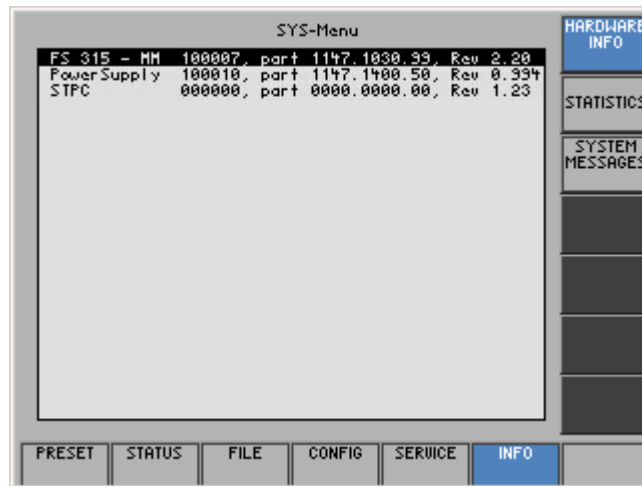
The menu name is highlighted and the appropriate functions are assigned the function keys [13].



Function key assignment

	Displays module data	(↗ 6-196)
	Displays instrument statistics	(↗ 6-196)
	Displays system messages	(↗ 6-197)

6.3.6.1 Displaying Module Data

Use You can display the serial number of the modules installed in the R&S FS315.

Calling module data

- Press the **HARDWARE INFO** function key in the **INFO** menu.

A table listing the current modules and the serial number is displayed.

FS 315 - MM	100007, part 1147.1030.39, Rev 2.20
Power Supply	100010, part 1147.1400.50, Rev 0.334
STFC	000000, part 0000.0000.00, Rev 1.23

6.3.6.2 Displaying Instrument Statistics

Use You can display the following R&S FS315 statistics:

- MODEL** - model designation
- SERIAL NUMBER** - serial number
- FW VERSION** - firmware version
- OPERATION TIME** - operating hours
- POWER ON CYCLES** - on/off cycles

Direct selection

- Press the **STATISTICS** function key in the **INFO** menu.

A table listing the current data is displayed.

MODEL	FS315
SERIAL NUMBER	100015, part 1147.0331.03
FW VERSION	MM10.26 from 04.11.2004
OPERATION TIME	745 h
POWER ON CYCLES	473

6.3.6.3 Displaying System Messages

Use

You can display the most recent R&S FS315 system messages in their order of occurrence. Operating errors are neither saved nor displayed.

System messages help the service personnel to analyze the instrument and handle errors, and should therefore only be deleted by them.

Displaying system messages

1. Press the **SYSTEM MESSAGES** function key in the **INFO** menu.

A table listing the current system messages is displayed.

2. Select a system message with the **▲** or **▼** cursor key [7].

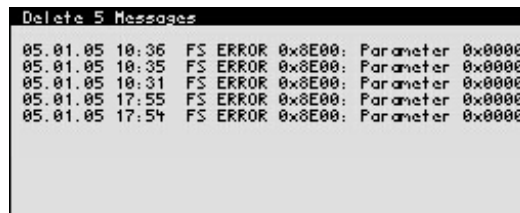

Delete 5 Messages				
05.01.05	10:36	FS	ERROR 0x8E00	Parameter 0x0000
05.01.05	10:35	FS	ERROR 0x8E00	Parameter 0x0000
05.01.05	10:31	FS	ERROR 0x8E00	Parameter 0x0000
05.01.05	17:55	FS	ERROR 0x8E00	Parameter 0x0000
05.01.05	17:54	FS	ERROR 0x8E00	Parameter 0x0000

3. Press the **ENTER** key [5].

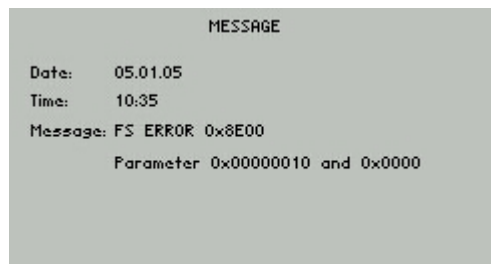

The current system message is clearly displayed with the date and time of their occurrence and the error code.



MESSAGE	
Date:	05.01.05
Time:	10:35
Message:	FS ERROR 0x8E00
	Parameter 0x00000010 and 0x0000

4. Press the **ENTER** key [5] for closing the display.

Deleting system messages (only for service)

1. Press the  function key in the  menu.
The table of current system messages is displayed.
2. Select the first line with the \blacktriangle or \blacktriangledown cursor key [7].



3. Press the **ENTER** key [5].
The field for the input of the password is displayed.



4. Enter the right password and confirm with the **ENTER** key [5].
The error messages are deleted.

Invalid password

If the password is invalid, the following message is displayed:



- Confirm the error message with the **ENTER** key [5].
The deleting of the error messages is broken off.

7 Remote Control/PC Software R&S FS315-K1

**Note**

The latest remote control commands and software drivers for the USB-interface of the R&S FS315 can be downloaded from the R&S Smart Instruments internet site:

www.smart-instruments.de

7.1 Applications of PC Software

Performance features

The PC Software R&S FS315-K1 allows convenient operation of the R&S FS315 by remote control via a PC. All the functions of the spectrum analyzer are supported. In addition, you can create test reports on your PC. Highlights of the software features are:

- Fast and simple transfer of measurements between the R&S FS315 and the PC
- Permanent analysis of ongoing sweeps to the PC with evaluation capabilities (Marker, Zoom, etc.)
- Practically unlimited memory capacity for storing traces and measurement information (comparison of current and previous information)
- Extended range of functions (Limit Lines, Log File)
- Creation of transducer sets
- Export of trace values (700 points) in .txt format for import into Microsoft Excel™
- Export of displayed data (screenshots) in JPEG format
- Printing the working window by standard Windows™ printer

Remote control using the keyboard and the mouse

All functions and measuring parameters can be set with the keyboard and the mouse using menus, toolbars or short keys.

Large display on the PC monitor

The monitor displays the current trace, the parameters and status fields required for measuring result analysis.

7.2 Installation and Configuration

System requirements The PC software runs on Windows™ 2000 and XP operating systems with USB interface.

7.2.1 Installing the PC Software

**Note**

To install the PC software, you must have administrator rights on your PC. (↗ Windows™ help).

Introduction

The PC software is installed in two steps. Firstly the remote control program for the R&S FS315 is installed. The R&S FS315 must not be connected at this time. Secondly the drivers are installed; at this time the instrument has to be connected.

7.2.1.1 Installing the Program

**Note**

The <Back> button enables the user to go back one step during installation. Installation can be interrupted by pressing <Cancel>.

Installation steps

1. Place the CD ROM, which came with the product, in your installation drive. The autorun function automatically initiates installation. Alternatively you may also initiate the installation in the start menu of Windows™ **Start\Run** using the **Setup.exe** from the CD.

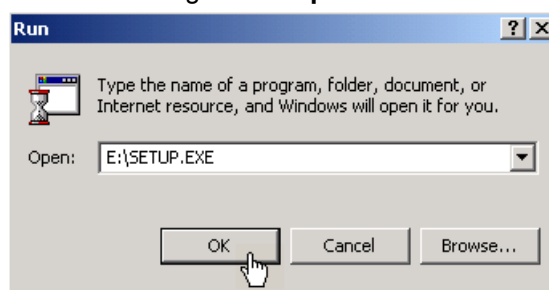

The installation is prepared and the installation wizard appears.

2. Click **<Next>** to continue the installation.



3. Click **<Browse>** to assign a new directory if you wish to install the program in another directory than proposed. Click **<Next>** to continue the installation.

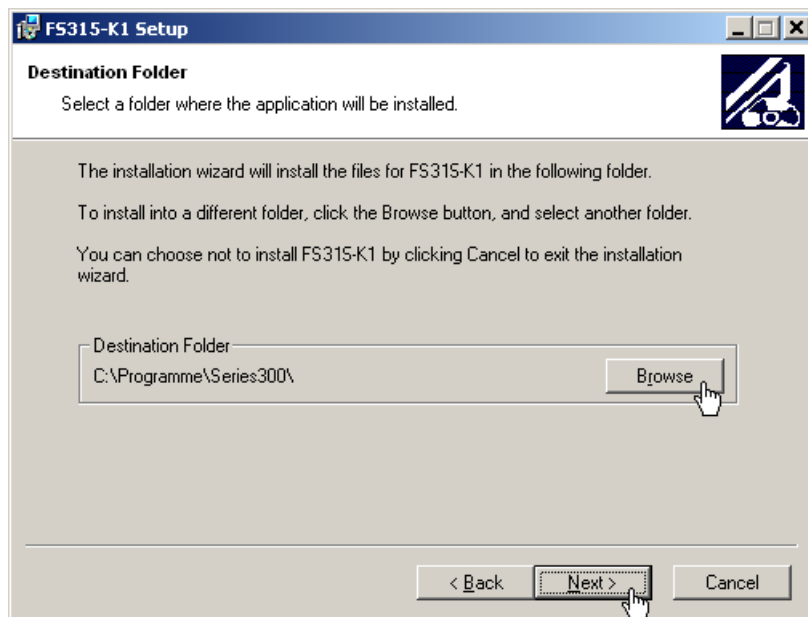

- 4. Click **<Next>** to continue the installation. Installation begins and the data are transferred to the PC. Please wait a moment.

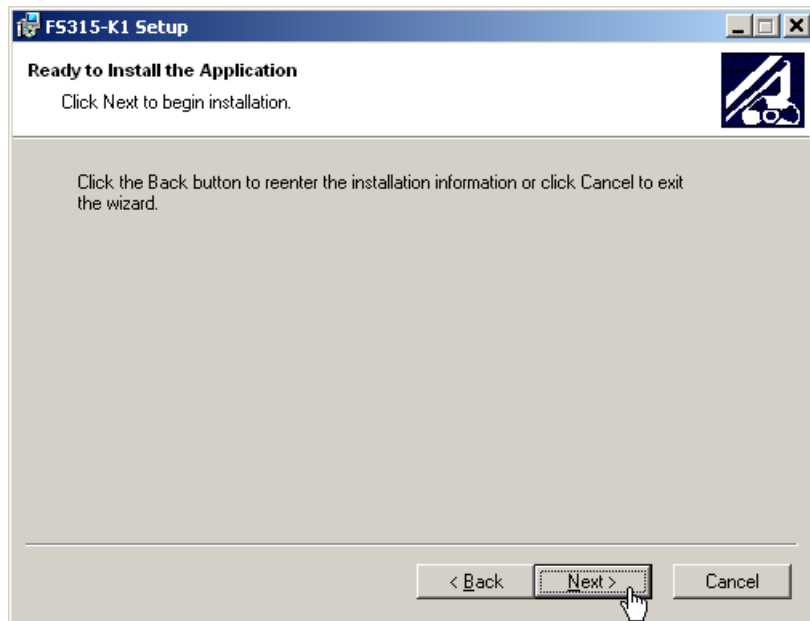

- 5. Click **<Finish>** to successfully complete the installation.



- 6. Click **<Yes>** to restart the computer.

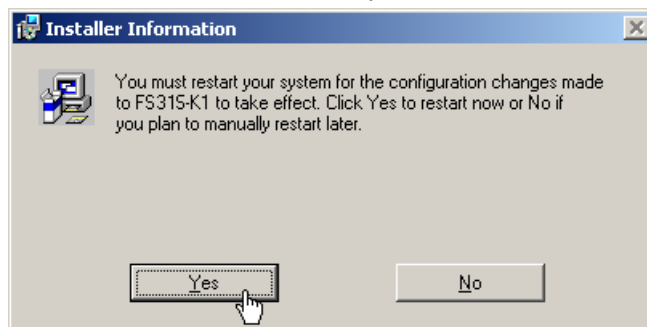

All new settings are now effective and the following appears in the Windows™ **Start\Programs\Rohde&Schwarz\Series300** start-up menu:

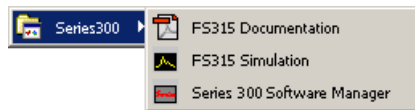

7. Install the device driver now (➤ next section).

7.2.1.2 Installing the Device Drivers

7.2.1.2.1 Installing Steps for Windows™ 2000

Connecting R&S FS315 to the PC

R&S FS315 is connected to the PC via the USB interface. The connection cable has two plug types. Plug A is connected to the computer (➤ computer manual) and plug B is connected to the R&S FS315 (➤ 2-36).

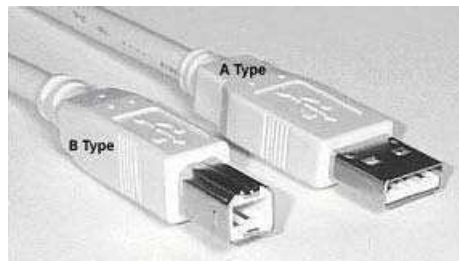

The CD ROM must be in the installation drive in order to install the driver.

1. Switch on the R&S FS315 and the PC.
2. Connect the instrument to the PC with the USB cable. The PC (Windows™) recognizes the connected instrument and reports new hardware. This message appears only when an R&S FS315 is installed for the first time.

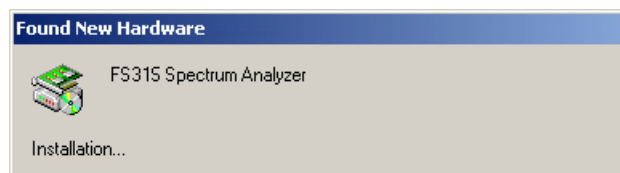

If the R&S FS315 is not automatically recognized, check that the USB master switch of the R&S FS315 is at **AUTO** (➤ 6-188).

Installing device drivers

3. Click **<Next>** to continue the installation.

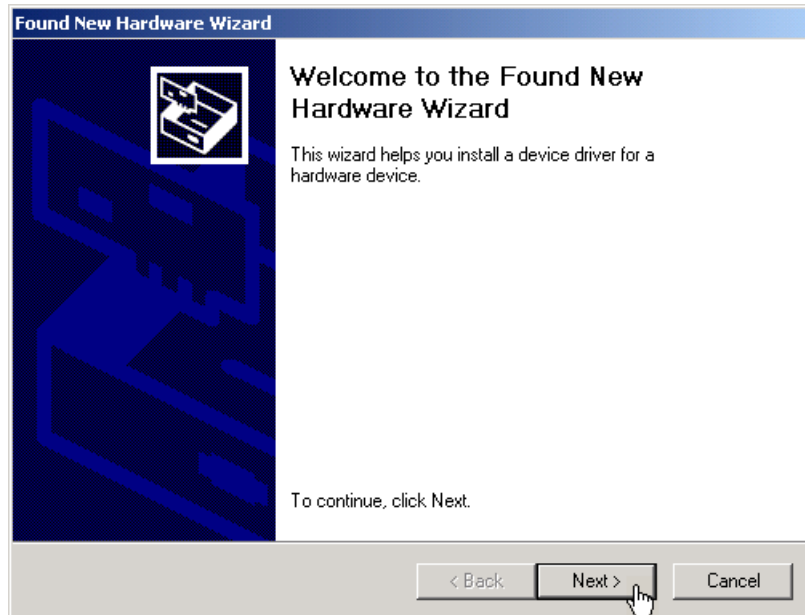

4. Select **Search for a suitable driver for my device** and click **<Next>** to continue the installation.



5. Select **CD-ROM drives** and click **<Next>** to continue the installation.

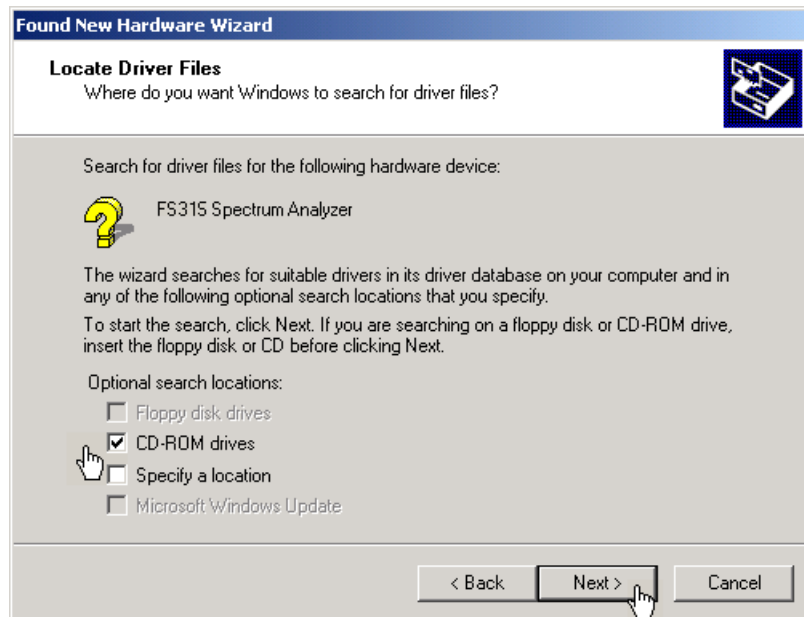

Then the search results for the driver data are displayed.

6. Click **<Next>** to continue the installation.

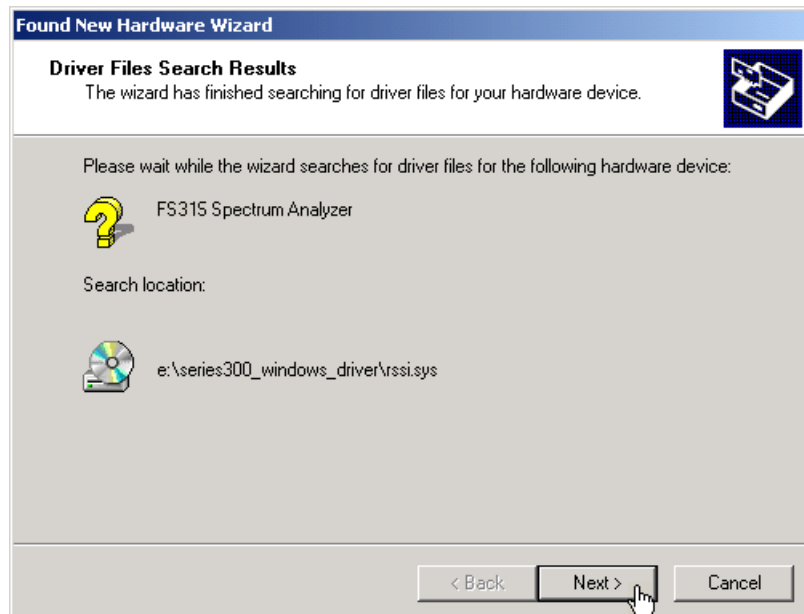

7. Click **<Finish>** to complete the installation.

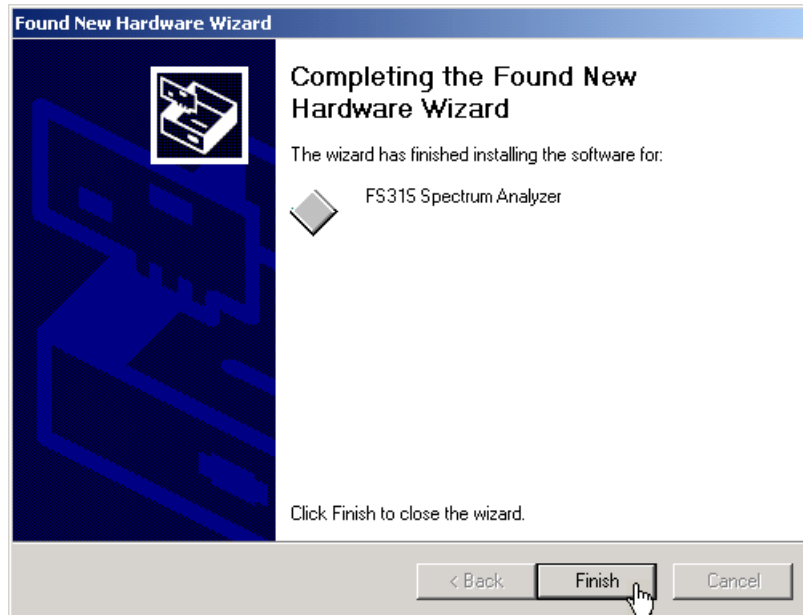

This is followed by the installation of the device driver for the **Rohde & Schwarz Power Supply**. Windows generally "remembers" all the necessary information when installing the Spectrum Analyzer R&S FS315 and installs the Rohde & Schwarz Power Supply without a query. However, depending on the system, the installation assistant might be activated.

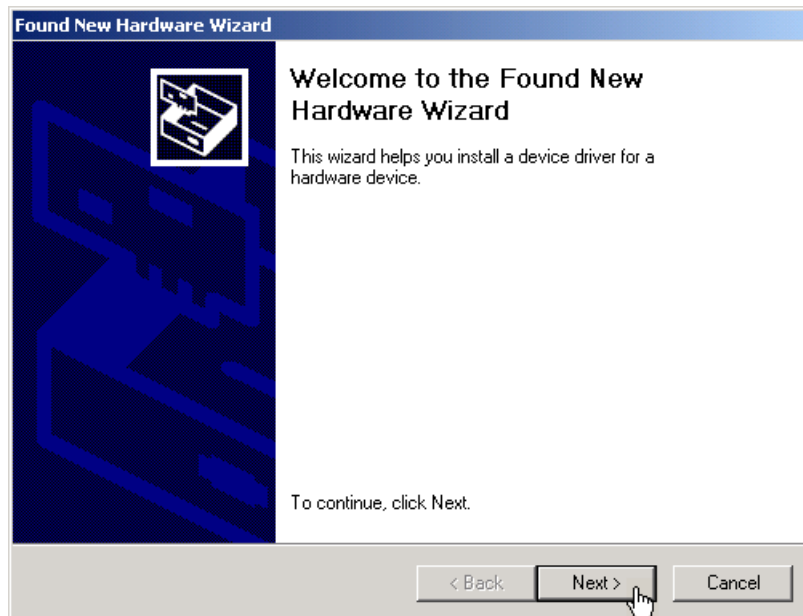

In this case, repeat instructions 3. to 7. to successfully complete the installation.

The drivers are now correctly installed and this can be checked using the device manager.

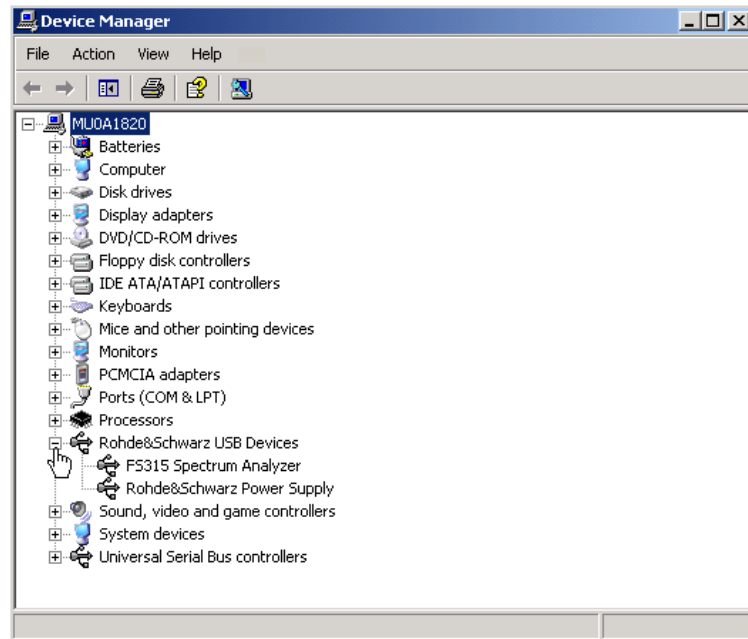

8. Create now the program version for specific instrument (↗ 7-212).

7.2.1.2.2 Installing Steps for Windows™ XP

Connecting R&S FS315 to the PC

R&S FS315 is connected to the PC via the USB interface. The connection cable has two plug types. Plug A is connected to the computer (↗ computer manual) and plug B is connected to the R&S FS315 (↗ 2-36).

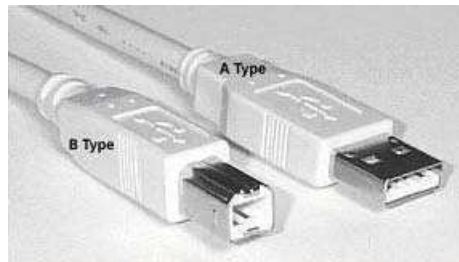

The CD ROM must be in the installation drive in order to install the driver.

1. Switch on the R&S FS315 and the PC.
2. Connect the instrument to the PC with the USB cable. The PC (Windows™) recognizes the instrument when it is connected and reports new hardware. This message appears only when an R&S FS315 is installed for the first time.

Installing device drivers

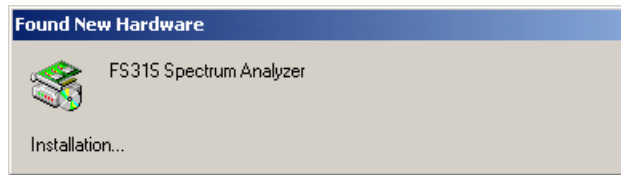

- If the R&S FS315 is not automatically recognized, check that the USB master switch of the R&S FS315 is at **AUTO** (↗ 6-188).
3. Select **Install the software automatically** and click **<Next>** to continue the installation.



4. Click **<OK>** to continue the installation.

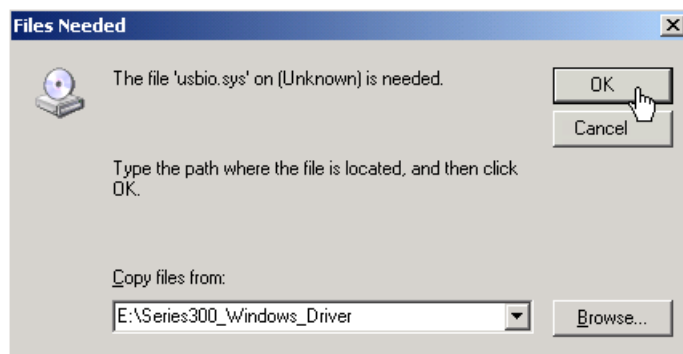

5. Click **<Finish>** to successfully complete the installation.

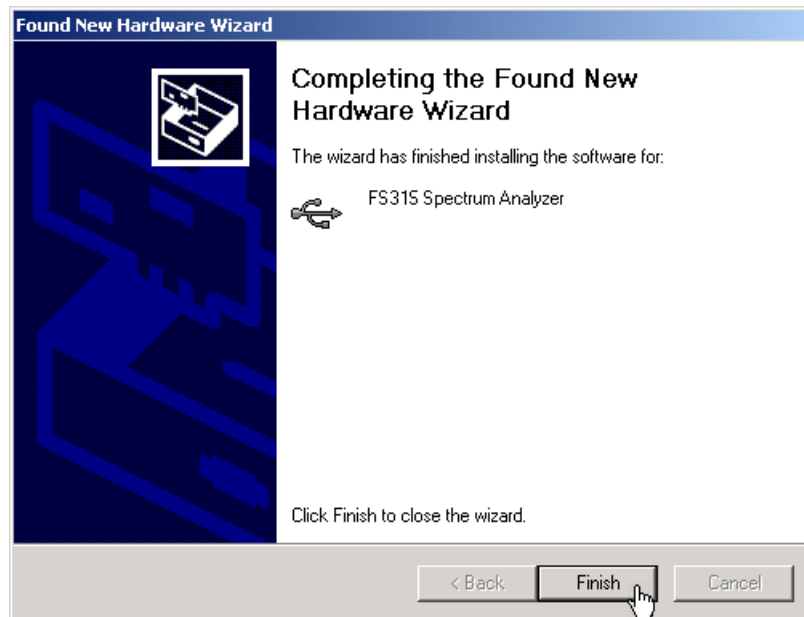

This is followed by the installation of the device driver for the **Rohde & Schwarz Power Supply**. Windows generally "remembers" all the necessary information when installing the Spectrum Analyzer R&S FS315 and installs the Rohde & Schwarz Power Supply without a query. However, depending on the system, the installation assistant might be activated.



In this case, repeat instructions 3. to 5. to successfully complete the installation.

The drivers are now correctly installed and this can be checked using the device manager.

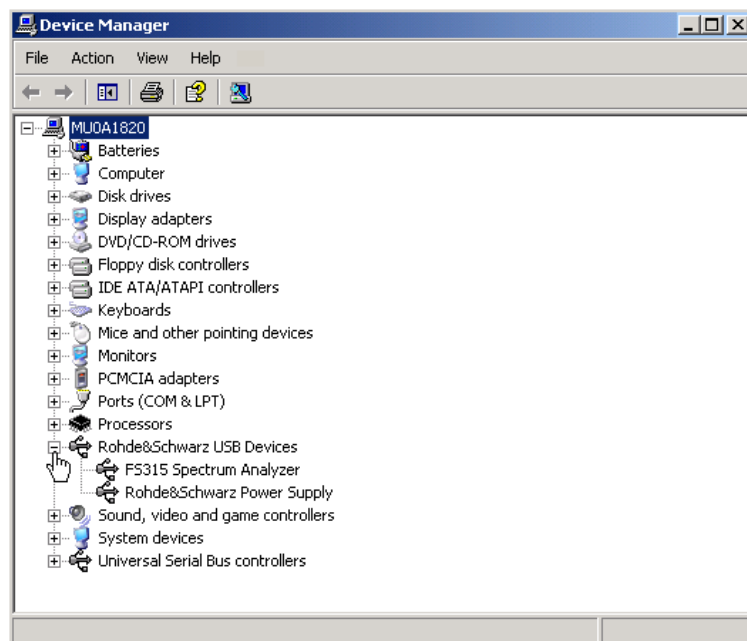

6. Create now the program version for specific instrument ([↗ 7-212](#)).

7.2.2 Connecting the PC-Software with the R&S FS315

Introduction

Due to the USB-Technology which is used in the R&S FS315, more than one instrument in the 300 Series can be connected with a PC at the same time. For each instrument a connection with the respective software which allows the opening and remote controlling of the specific instrument has to be created.

The creation of an instrument-specific connection of the Software R&S FS315-K1 by using the provided Series 300 Software Manager is explained in the following section. Before this process can be started, the R&S FS315-K1 Software needs to be installed on your PC (↗ 7-200) and one or more instruments have to be connected to the PC via USB-cable (↗ 7-216).

7.2.2.1 Starting the Series 300 Software Manager

Starting the service program

- In the Windows™ start-up directory select:
Start\Programs\Rohde&Schwarz\Series300\Series 300 Software Manager

The service program initializes. The program interface is divided into two areas:

- I A list of all previously connected Smart instruments
- II Information, status fields and command buttons for authorization

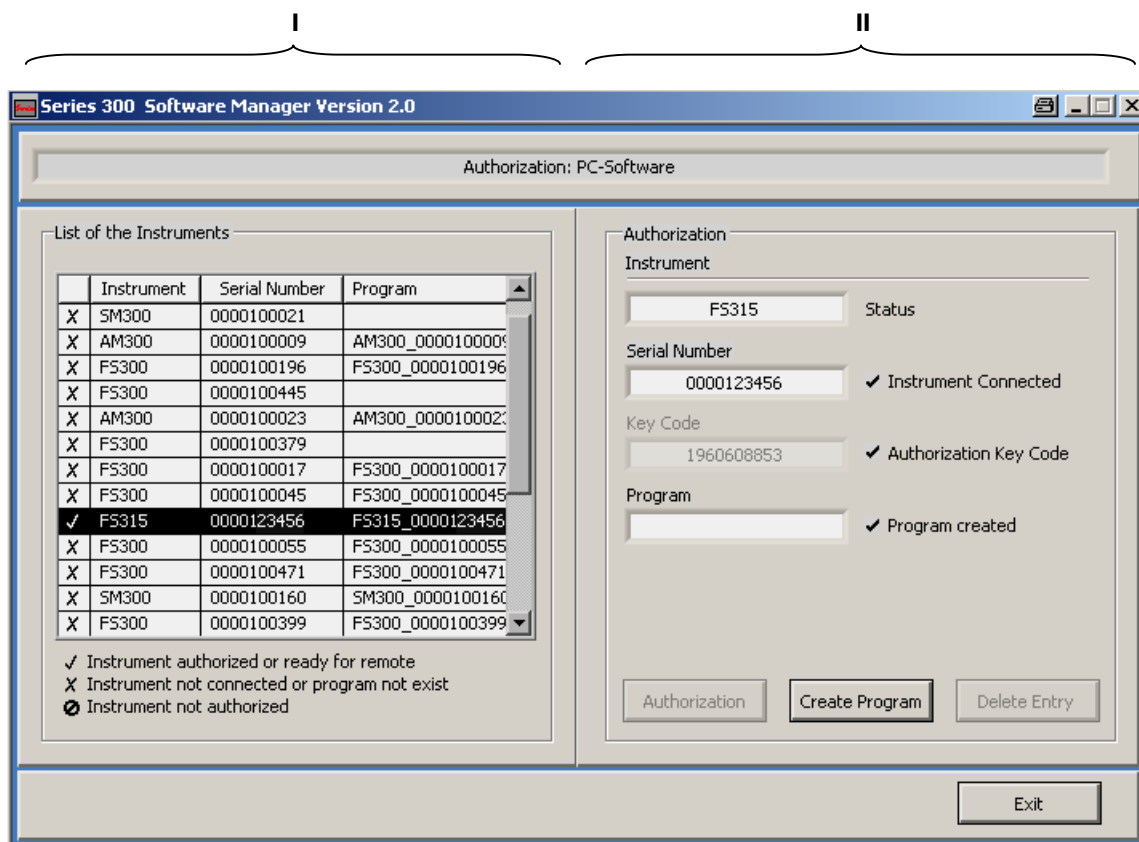

7.2.2.2 Creating the Program Version

Selecting the instrument

- In I click on the instrument for which you create a link.

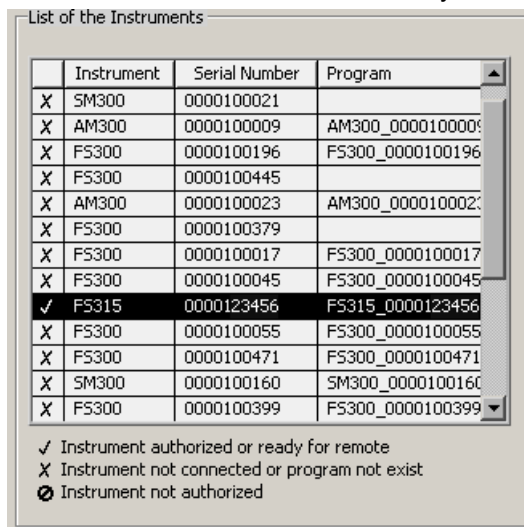

Creating the program version for specific instrument

- Click <Create Program>. A program version for specific instrument is created and displayed in II with the status (✓). The program number is created from the instrument name (FS315) and the serial number (0000xxxxxx).

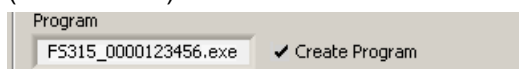

- In II click <Exit> to close the service program. After correctly creating the program version, the option **FS315 0000xxxxxx** is available in the Windows™ start-up menu **Start\Programs\Rohde & Schwarz\Series300**.

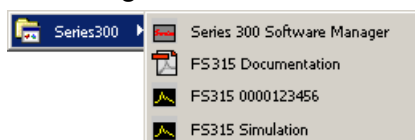

Now the program **FS315 0000xxxxxx** can be started (↗ 7-217)

7.2.3 Uninstalling the PC Software

Installation steps for
Windows™ 2000

1. Place the CD ROM, which came with the product, in the installation drive. The autorun function automatically initiates installation. Alternatively you may also initiate the installation in the start menu of Windows™ **Start\Run** using the **Setup.exe** from the CD. The uninstallation is prepared and the uninstallation assistant appears.



2. Click <Next> to continue the uninstallation.



3. Click <Finish> to complete the uninstallation.

 **Note**

The PC software can also be uninstalled using the Windows™ control panel.

7.2.4 Update PC Software

Introduction

Old versions of the PC-Software can be updated with the Series 300 Software Manager. Therefore the old version has to be uninstalled (↗ 7-213). The new version can then be installed (↗ 7-200). After that, the links which already existing to the listed instruments have to be updated manually.

Starting the service program

1. Start the Series 300 Software Manager (↗ 7-211).
The service program initializes and the window „Authorization: PC-Software“ is displayed.
2. Click on the top bar **Authorization: PC-Software** and choose “Service: Update PC-Software” from the menu.

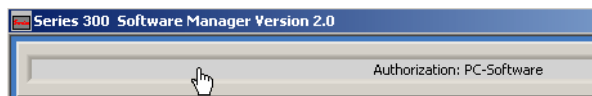

The “Update PC-Software” window is displayed and has the following two partitions:

- I List of all Smart-Instruments that have been previously connected
- II Display of the current version of the program and the available version

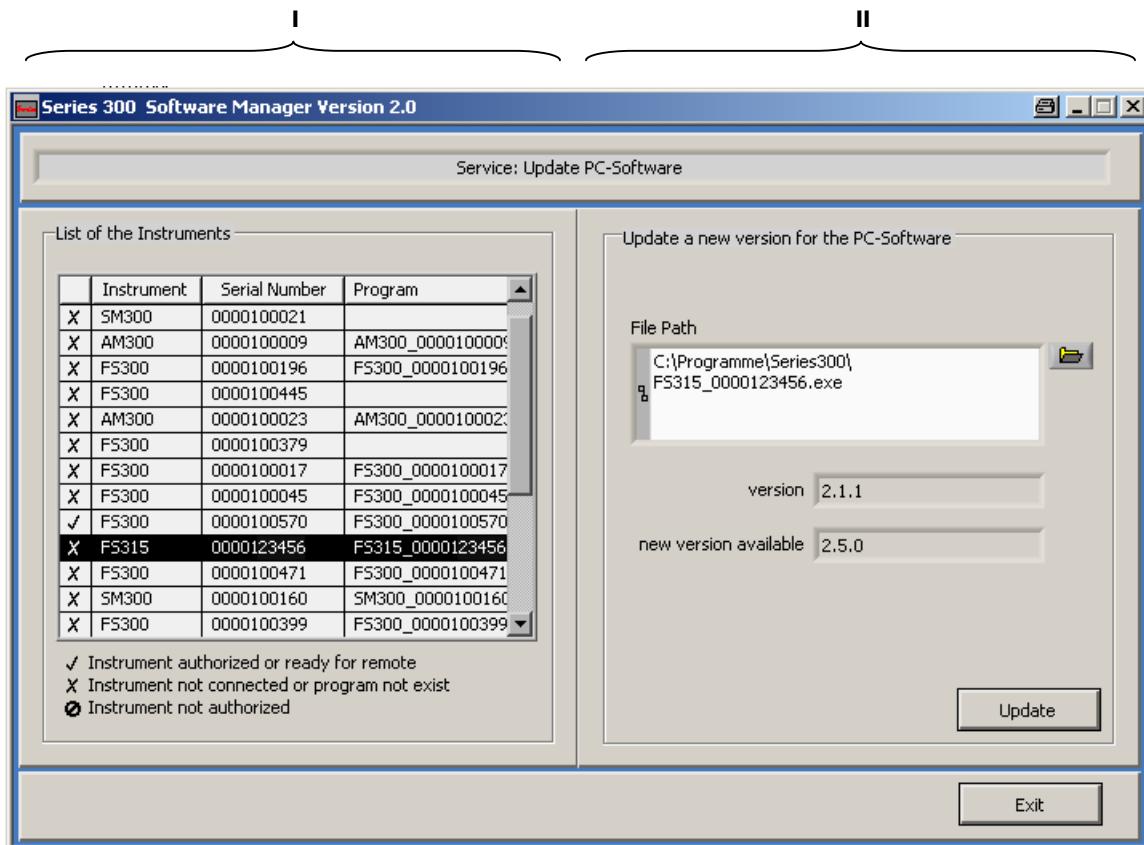

Selecting the instrument

- In I click on the instrument for which you wish to update a link.

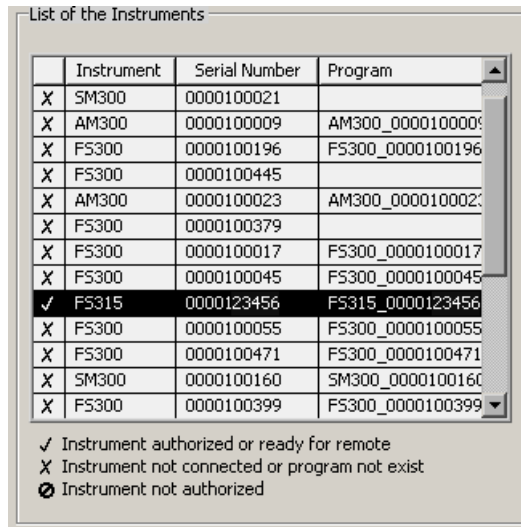

Updating the link

- Click in II on <Update>, to update the displayed link.
- Click in II on <Exit>, to shut down the service program. The updated connection **FS315 0000xxxxxx** is displayed in the Windows™ Start Menu **Start\Programme\Rohde & Schwarz\Series300**.

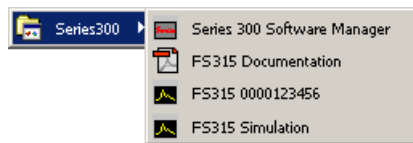

Now the program **FS315 0000xxxxxx** can be started (↗ 7-217).

7.3 Starting the Remote Control

7.3.1 Connecting the Instrument to the PC

**Note**

PC software R&S FS315-K1 must be installed before you can connect the R&S FS315 to the PC (➔ 7-200).

Introduction

R&S FS315 is connected to the PC via the USB interface. The connection cable has two plug types. Plug A is connected to the computer (➔ computer manual) and plug B is connected to the R&S FS315 (➔ 2-36).

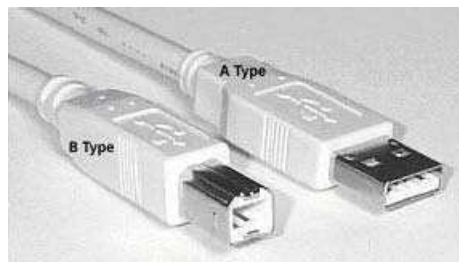
**Prepare remote control**

1. Switch on the R&S FS315 and the computer.

Connect instrument to PC

2. Connect the instrument to the computer with the USB cable. The computer recognizes the attached instrument and sets up a connection. The following message appears on the monitor of the R&S FS315:

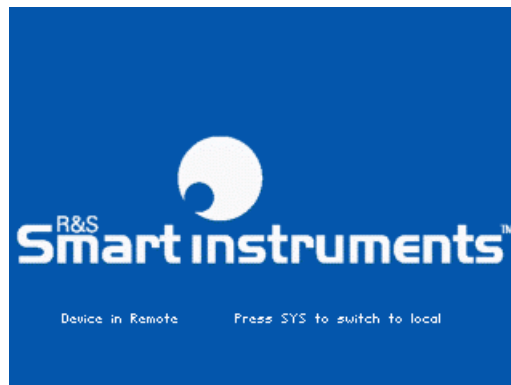

If the R&S FS315 is not automatically recognized, please check that the USB master switch of the R&S FS315 is at position **AUTO** (➔ 6-188).

**Note**

In remote control mode, control of the R&S FS315 is deactivated and can only be reactivated by pressing the BACK/SYS key at the front panel of the instrument. Switching from remote to local control takes approximately 5 seconds.

7.3.2 Starting the Program

- Starting the program
1. In the Windows™ start-up directory click on:
Start\Programs\Rohde&Schwarz\Series300\FS315 0000xxxxxx

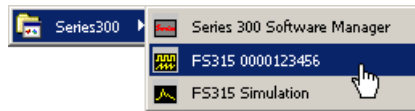

If the link is not available

2. If the program does not start, then click with the right mouse button in the Windows™ start-up directory on:
Start\Programs\Rohde&Schwarz\Series300\FS315 0000xxxxxx
Click **Properties**.

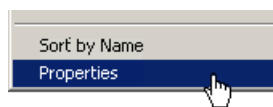

Click **<OK>** to create a link between the program and start-up directory.

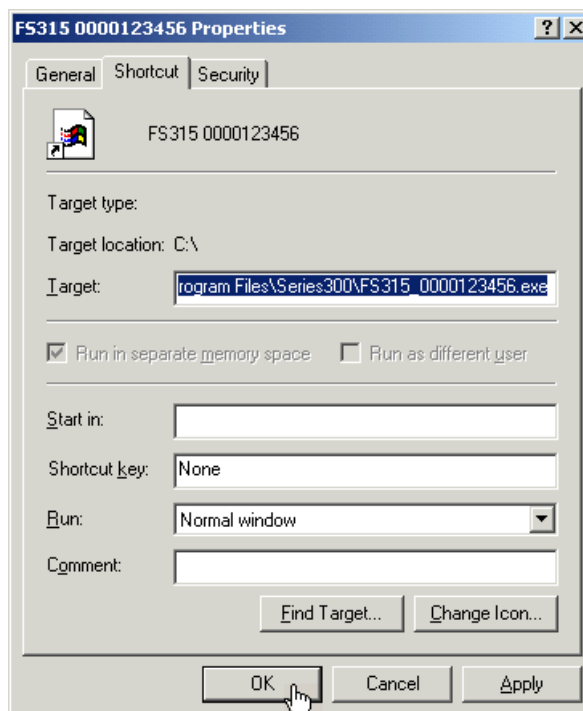

Start the program again (↖ above, instruction 1.)

Program interface

The program starts up and you may begin using the R&S FS315 remote control.

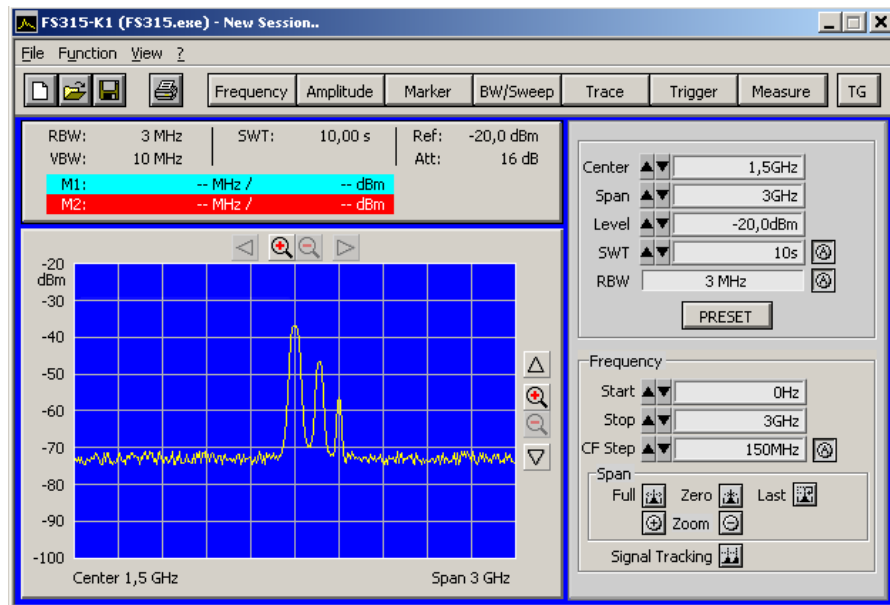

Loading the current instrument settings

A new session opens automatically when you start the program. The current R&S FS315 settings are loaded. The following settings are display and evaluation functions and are not transferred to the PC software:

- Marker functions (↗ 7-238)
- Scale of measuring diagram (Range, Unit)
- Trace functions (↗ 7-241)
- Measure functions (↗ 7-243)

 **Note**

If the message **Device not connected** appears on the program interface, you need to check the connection to the instrument (↗ 7-216).

7.3.3 Closing the Remote Control

Closing the program 1. In Windows™ click on the close symbol **x**.

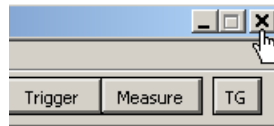

You may also select the option **Exit** in the pull-down menu **File**.

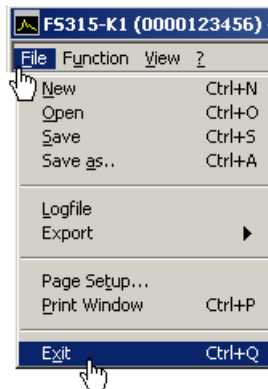

Closing the remote control

2. Remove the USB cable from one side or press the BACK/SYS key at the front panel of the R&S FS315.

Switching between remote and local control takes approximately 5 seconds.

7.4 Getting Started

7.4.1 Level and Frequency Measurement

7.4.1.1 Measuring Task



Caution

The input stage of the R&S FS315 can be destroyed by overloads or DC components. If there is a possibility that the limits specified in the data sheet may be violated, the input must be protected with an attenuator and/or a DC block.

Measurement problem

Determining the level and frequency of a signal is one of the most common measuring tasks which can be solved with a spectrum analyzer. When measuring an unknown signal the PRESET (factory) setting (↷ 6-70) is used as a start-up setting.

Solution

Important functions for the level and frequency measurement are setting the center frequency (CENTER) and the frequency display span (SPAN) as well as the MARKER functions.

7.4.1.2 Measuring Sequence

Introduction

In this example, a signal with a frequency of 200 MHz and a level of –30 dBm is applied to the HF input of the R&S FS315. The center frequency and the frequency display span are set manually. Carry out the following steps:

- Reset the R&S FS315
- Apply a signal to the R&S FS315
- Set the center frequency (Center) to 200 MHz
- Reduce frequency display span (Span) to 1 MHz
- Measure the level and frequency with the marker
- Measure the frequency with the built-in frequency counter

Resetting the R&S FS315

1. Start the PC software (FS315 0000123456.EXE) on your PC.



Alternatively you may also open a new session when the PC software is already started. To do so, press **<Ctrl+N>**. The default settings are now active (➔ 6-70).

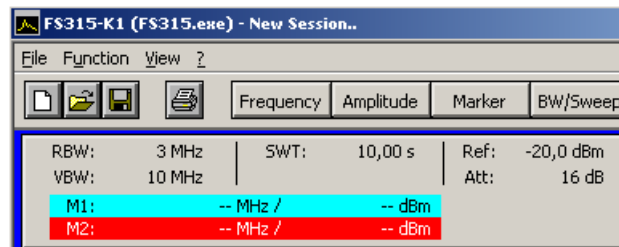

Applying a signal to the R&S FS315

2. Apply the measuring signal to the HF input socket.



Setting the center frequency (Center) to 200 MHz

3. Press **<Ctrl+Shift+C>**. The input window **Center** is activ.



4. Enter the value **<200M>** with the alphanumeric keys. Complete the input by pressing **<Enter>**.

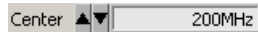

Reducing the frequency display span (Span) to 1 MHz

5. Press **<Ctrl+Shift+S>**. The input window **Span** is active.



6. Enter the value **<1M>** with the numeric keys. Complete the input by pressing **<Enter>**.

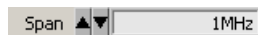

Measuring the level and frequency with the marker

7. Press **<Ctrl+Shift+M>**. The marker jumps to the signal peak. An arrow appears above of the diagram at the position of the marker.

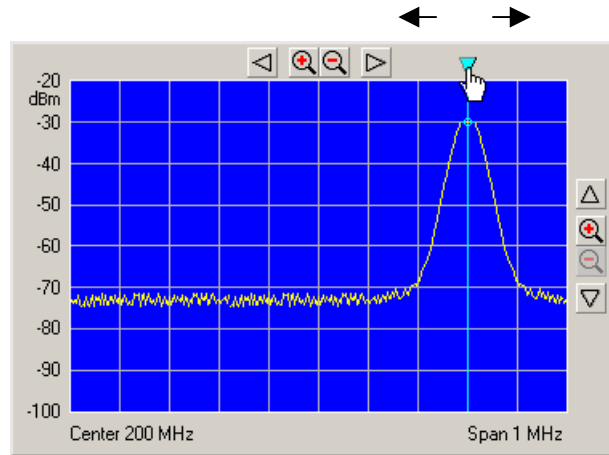

8. You can change the position of the marker by moving the arrow with the left **<Mouse Button>**. The parameter field above shows the marker values M1.

RBW:	20 kHz	SWT:	10,00 s	Ref:	-30,0 dBm
VBW:	50 kHz			Att:	6 dB
M1:	200 MHz /				-30,0 dBm
M2:	-- MHz /				-- dBm

Measuring the frequency with the built-in frequency counter

9. In the **Function display Marker** click on **<Counter>** with the left **<Mouse Button>**

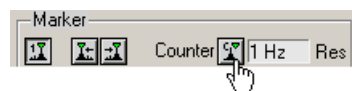

10. Set the resolution of the frequency counter in the selection window **<Res>**.



The exact frequency value C1 can be seen in the parameter field above.

RBW:	20 kHz	SWT:	10,00 s	Ref:	-30,0 dBm
VBW:	50 kHz			Att:	6 dB
C1:	200003520 Hz /				-30,0 dBm
M2:	-- MHz /				-- dBm

7.5 Control Concept

7.5.1 PC Monitor Display

Introduction

The PC monitor provides continuous information about the results and parameters of the selected measuring functions. The display format for the measuring results and the insertion of the function displays depend on the current settings.

Structure of the program interface

The program interface is divided into three areas:

- I Diagram
- II Menus
- III Functions

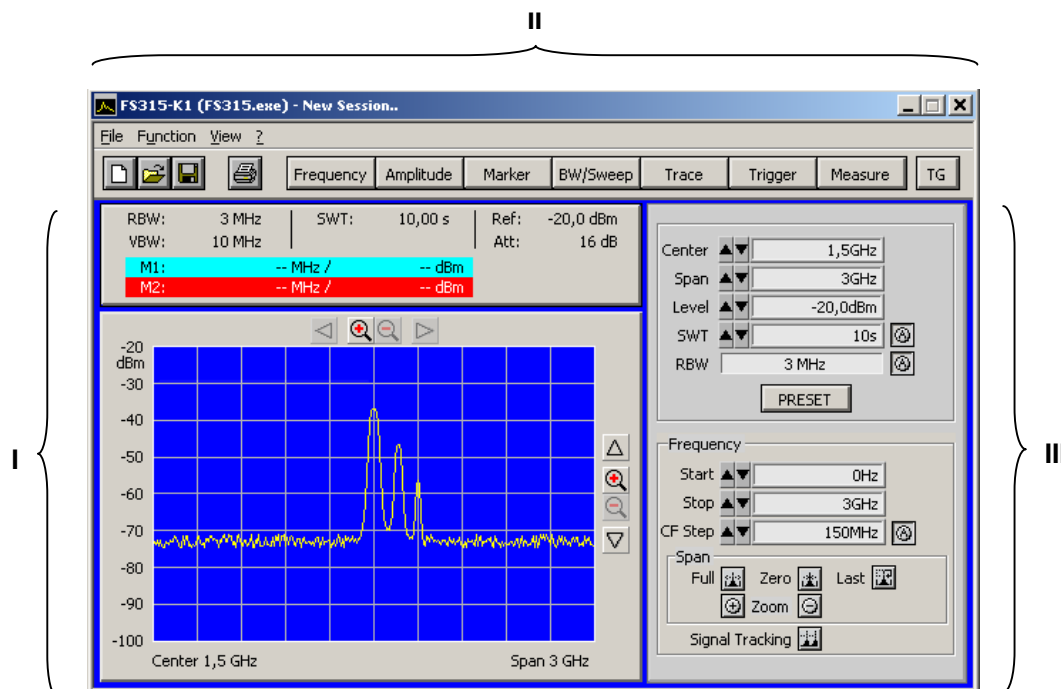

7.5.1.1 Diagram

Diagram displays

The diagram area contains:

- Measuring diagram with scale (a) and traces (i)
- Measuring value displays, e.g., display lines (h) and markers (f)
- Limit lines (k)
- Parameter field (c) and status displays (e)
- Navigation elements in x (b) and y direction (g)
- Pop-up error messages (d)

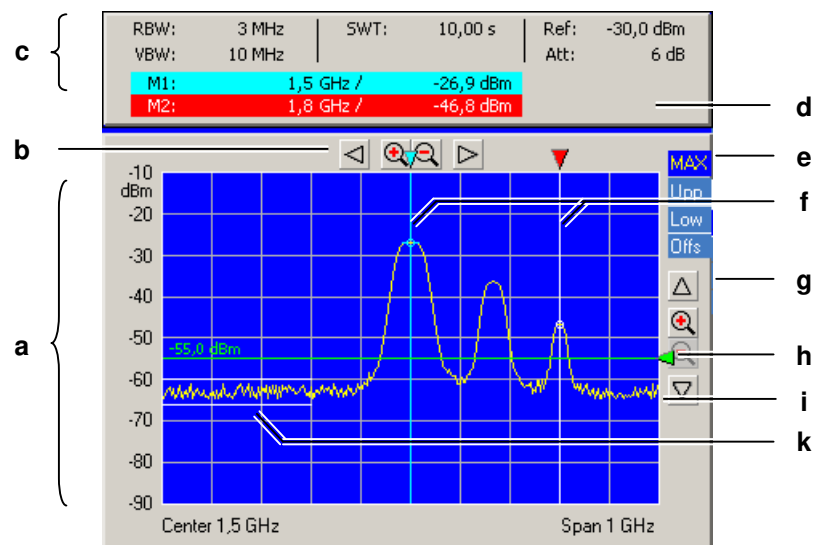

Measuring diagram

A 10 x 8 grid is superimposed on the diagram to facilitate traces analysis.

Parameter field and status display

The following values are displayed in the parameter field:

- RBW:** - current resolution bandwidth (LN for max. sensitivity)
- VBW:** - current video bandwidth
- SWT:** - current sweep time
- M1:** - marker 1 with marker position and level value
- M2:** - marker 2 with marker position and level value
- Ref:** - current reference level
- Att:** - current input attenuation

The status display provides information about:

- MAX** - current trace display, e.g., maximum value
- Upp** - limit line Upp is switched on
- Low** - limit line Low is switched on
- Offs** - level offset is switched on

Note

Error messages are closed after several seconds.

Further system messages and warnings in illegal modes of operation are described in detail in chapter 9.

7.5.1.2 Menus

Calling up and displaying menus

Different pull-down menus can be accessed in the menu area.

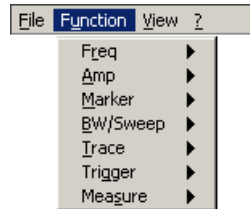

In addition, Windows™-typical menu items can be called up via a toolbar (icons).



Menus for setting the measuring parameters and functions are also available as a toolbar and can be selected directly.

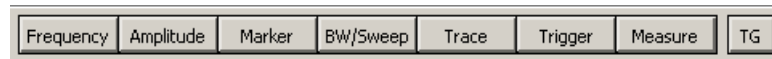

Note

The ► arrow after a menu option in the pull-down menu indicates that a sub-menu will appear after opening, e.g., **Amp** ►.

7.5.1.3 Functions

Main functions display

The **main functions** of the R&S FS315 are always displayed in the top part of the function display. These are:

- Center frequency (Center)
- Frequency display span (Span)
- Reference level (Level)
- Sweep time (SWT)
- Resolution band width (RBW)

These may be changed at any time.

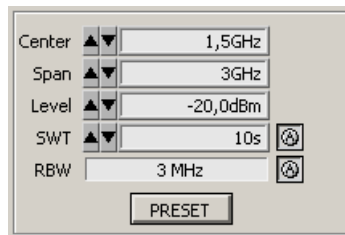

Inserting specific functions

In the lower part of the function display, different function displays with input fields (1), selection fields (2) and control buttons (3) are displayed e.g., **Amplitude** or **Trigger** etc., according to menu selection (↗ 7-230).

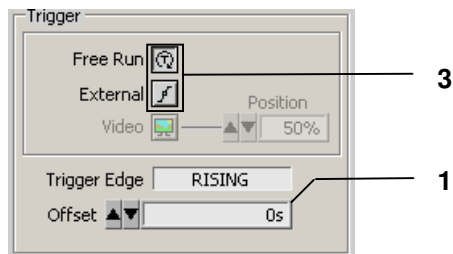
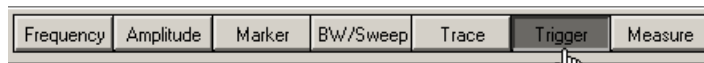
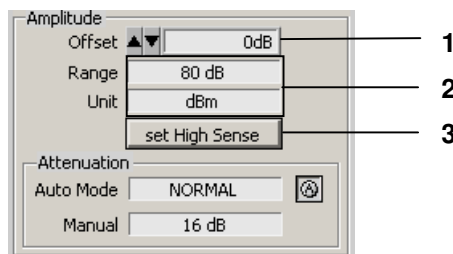
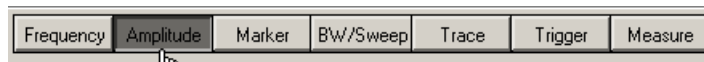

Note: If a selection is not highlighted, it has currently no function (current setting).

7.5.2 Input via Keyboard and Mouse

Introduction The R&S FS315 is remote controlled via PC keyboard and mouse with the help of menus. The most important keys are:

- Numeric keys 0 ... 9
- Arrow keys ◀ / ▶ / ▼ / ▲
- Function keys F5 ... F11
- Action keys Enter, Esc
- Tab key Tab
- Space bar Space
- Mouse buttons left, right

7.5.2.1 Numeric Keys

Function The numeric keys are used to enter numerical parameters.

- 0 ... 9 – At cursor, insert numbers <0> ... <9>



- ,
- At cursor, insert decimal separating sign <,> or <.> dependent on PC system settings



- – At cursor, insert minus sign <->



7.5.2.2 Arrow Keys

Function In addition to numeric keys, the arrow keys are used to enter parameters. They can also be used to navigate through the menus.

- ◀ / ▶ / ▼ / ▲ The arrow keys have the following functions:

- **Navigating the pull-down menus** with all arrow keys

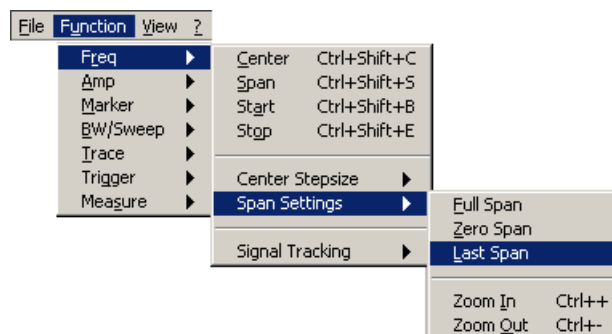

- **Positioning** the cursor in the input fields with the ◀ / ▶ arrow keys

Center ▲▼ | 1,5GHz

- **Increasing** or **decreasing** numerical parameter inputs with the ▼ / ▲ arrow keys

Center ▲▼ | 1,5GHz → 4 x ▼ Center ▲▼ | 1,1GHz

Center ▲▼ | 1,5GHz → 4 x ▲ Center ▲▼ | 1,9GHz

7.5.2.3 Function Keys

Function

Function keys open the menus to set the measuring parameters and measuring functions and insert the corresponding function display.

F5	– Inserts the Frequency function display	(↗ 7-236)
F6	– Inserts the Amplitude function display	(↗ 7-237)
F7	– Inserts the Marker function display	(↗ 7-238)
F8	– Inserts the BW/Sweep function display	(↗ 7-240)
F9	– Inserts the Trace function display	(↗ 7-241)
F10	– Inserts the Trigger function display	(↗ 7-242)
F11	– Inserts the Measure function display	(↗ 7-243)

7.5.2.4 Action Keys (Enter, Esc)

Function The action keys complete the menu-operated settings.

- Enter key** – This key **closes the input or selection**. The **new value** now applies.
- Esc key** – This key **closes the selection**. The **old value** is preserved.

7.5.2.5 Tab Key

Function The tab key activates the input fields, the selection fields and the buttons within a function display.

- Tab key** – Jumps from one control element to another in a function display

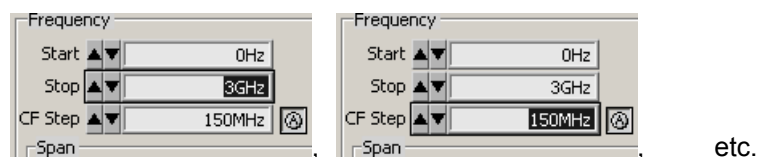

Note: The tab key can be only used to make selections when an input field, a selection field or a control button has been selected in the function display via a menu (↵ 7-230) or with the mouse (↵ 7-229).

7.5.2.6 Space Key

Function After selecting an input field, a selection field or a control button with the tab key, different actions are initiated by pressing the space key:

- Space key** – Immediate function **execution** of the function e.g., Zoom +

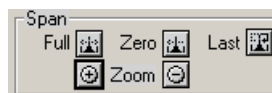

- **Toggle** a setting, e.g., switch on/off signal tracking



- **Open** selection fields, e.g., set the measuring unit for Amplitude

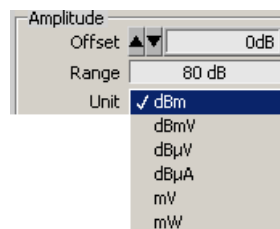

7.5.2.7 Mouse Buttons

Function Placing the mouse pointer over and clicking on any program interface item will allow for different actions.

- Left mouse button – Pull-down menus can be **opened** with the mouse

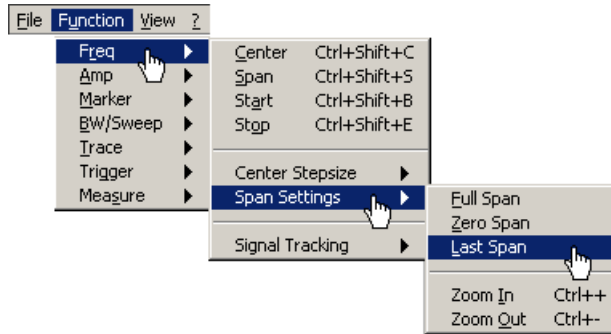

- The contents of input fields can be **highlighted** with mouse button pressed and held



- The cursor can be **positioned** in the input fields by clicking the mouse button



- Selection fields can be **opened** and settings can be **selected** with mouse button pressed and held



- Immediate **execution** of any function by clicking the mouse button

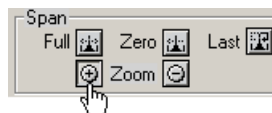

- **Toggling** a setting with multiple mouse clicks



- **Moving** markers and limits, also in the diagram area, with mouse button pressed and held

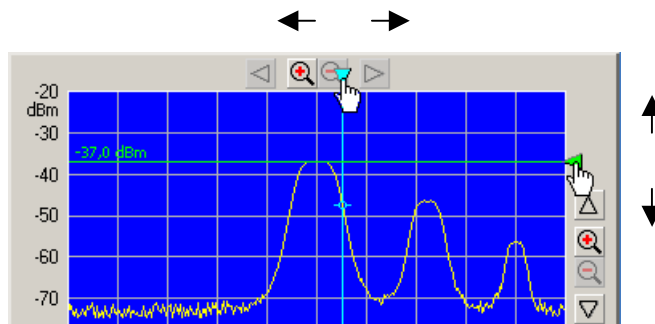

7.5.3 Calling up and Changing the Menus

Various methods are possible

The R&S FS315 is remote controlled via a menu. The keyboard and the mouse can be used to select a menu (↗ 7-226).

Instrument parameters (and program functions) can be selected in different ways on the PC interface, e.g., unit for the level display:

- **Selecting with the pull-down menu**

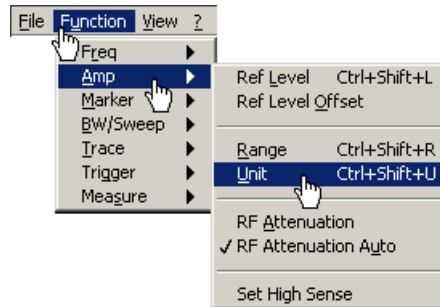

- **Selecting with short keys**

Unit Ctrl+Shift+U

- **Selecting with the toolbar menu and selecting the selection field directly in the function display**

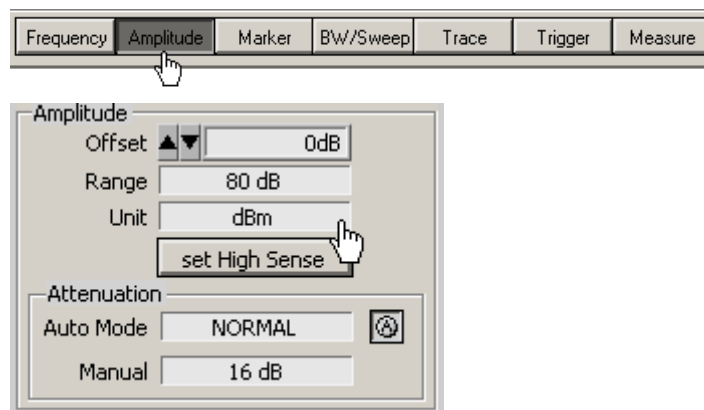

Note

The ▶ arrow after a menu option in the pull-down menu indicates that a sub-menu will appear after opening, e.g. Amp ▶.

7.5.4 Setting the Parameters

Introduction

Parameters can be set in different ways:

- Selecting an instrument function directly (command button)
- Selecting settings in the selection fields
- Inputting numerical parameters in the input fields
- Moving markers

The keyboard and mouse can be used for the settings (➔ 7-226).

7.5.4.1 Direct Selection of a Instrument Function

Various methods are possible

Some instrument functions are executed immediately after selection, e.g., automatic setting of the HF input attenuator.

Instrument parameters (control buttons) can be selected in different ways:

- **Selecting and switching on using a pull-down menu.** The current setting is indicated by a tick mark (✓).

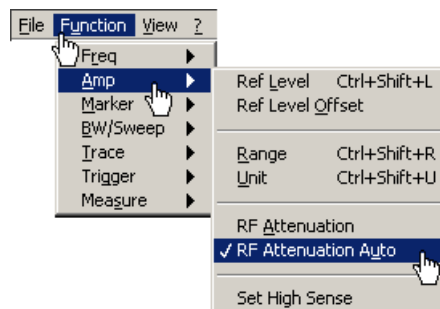

- **Selecting using a toolbar menu and switching on in the function display**

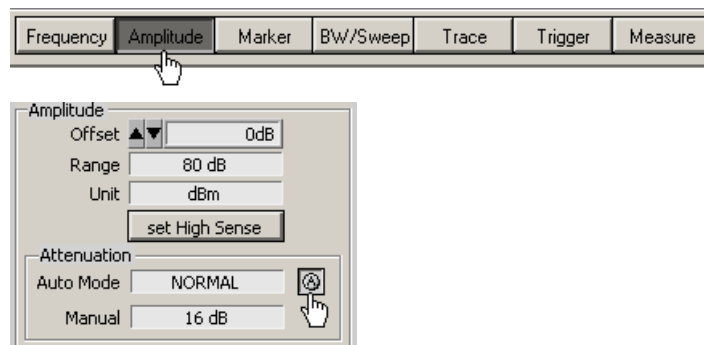

7.5.4.2 Selecting the Settings

Setting the instrument functions in selection windows

Several settings are available for certain instrument functions, e.g., level display unit.

The **selection window** can be reached in a number of different ways (↗ 7-230), e.g., selection using the toolbar menu.

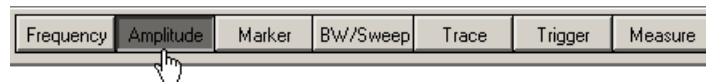

Opening the selection window and selecting the instrument functions takes place in the **function display**. The current setting is indicated by a tick mark (✓).

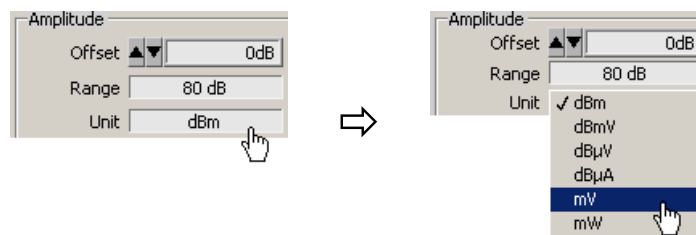

7.5.4.3 Inputting the Numerical Parameters

Setting instrument functions in the input window

Two methods are available for entering the numerical parameters, e.g., inputting the frequency display range:

- **Inputting** a value with **numeric keys**
- **Inputting** a value with **arrow keys**

You should use the arrow keys for inputting if the value to be measured cannot be determined accurately beforehand. Given that the screen is constantly updated while the values are changing, browsing is possible.

Selecting input window

The input fields can be selected in a number of different ways (↗ 7-230), e.g., using short keys:



Inputting with numeric keys

Inputting using the numeric keys can be done in a number of different ways:

- **Highlighting and overwriting numbers**

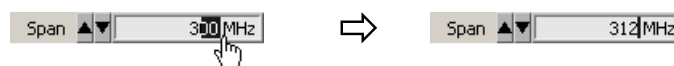

- **Selecting a decimal point and inserting numbers**

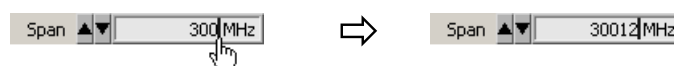

Selecting the unit

The entry is made in the active measurement unit, which is indicated after the numeric value in the entry field and can be changed. Make sure that there are no spaces between the numeric figure and the measurement unit.

You may omit the base unit (e.g. Hz, s, dBm). However, you must specify the unit size (valid values: G, M, k, m, u, n, p).

Input examples

- **Span:**

15k ⇨ 

15kHz ⇨ 

150000 ⇨ 

15M ⇨ 

- **Sweep Time:**

34m ⇨ 

34ms ⇨ 

34 ⇨ 

34u ⇨ 

Inputting with arrow keys

Inputting using the arrow keys can be done in a number of different ways:

- Selecting a decimal point and incrementation or decrementation **with the**
 ▼ / ▲ **arrow keys on the keyboard**

 ⇨ 4 x ▼ 

- Incrementing or decrementing **with the arrow keys on the user interface**

 ⇨ 4 x 

Note: When entering the center frequency, increment size can be set with the arrow keys (↵ 7-236). The value is then incremented or decremented according to this set value.

Invalid parameter entry

If a parameter entry is invalid, the value will automatically be limited.

7.5.4.4 Moving the Markers

Introduction

In the diagram area, lines (markers, limits, etc.) can be inserted to analyze the trace. In addition, an arrow is displayed at the edge of the diagram at the position of the corresponding line. The position of the line can be changed by moving the arrow with the left mouse button.

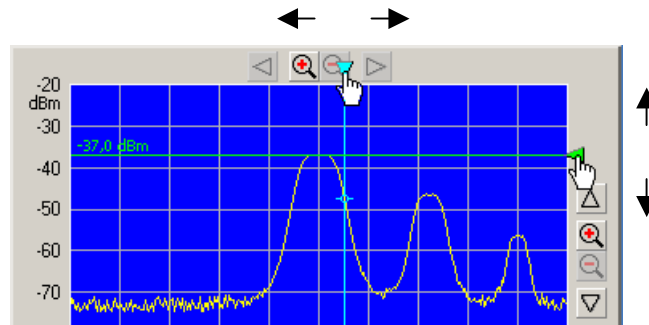

The marker values can be read in the parameter fields above.

RBW:	1 MHz	SWT:	10,00 s	Ref:	-20,0 dBm
VBW:	1 MHz			Att:	16 dB
M1:	1,538709677 GHz /				-46,8 dBm
M2:	-- MHz /				-- dBm

7.6 Overview of all Menus and Functions (Shortcuts)

7.6.1 File

Menus to prepare for a Session

The following options are available in the pull-down menu **File**: open, save and close a session; create a log file; export data; print screen.

New	Ctrl+N	Begin new session	(↗ 7-246)
Open	Ctrl+O	Open saved session	(↗ 7-247)
Save	Ctrl+S	Save current session	(↗ 7-248)
Save as..	Ctrl+A	Save current session as	(↗ 7-248)
Logfile		Create a log file for the current session	(↗ 7-249)
Export	▶	Export data	(↗ 7-255)
Page Setup...		Page setup for printing	(↗ 7-257)
Print Window	Ctrl+P	Print current window	(↗ 7-257)
Exit	Ctrl+Q	Exit program	(↗ 7-219)

7.6.2 Function

**Note**

Instrument functions are accurately described in chapter 6 of the R&S FS315 manual.

Menus for configuring and starting measurements

The menus used to set the spectrum analyzer are displayed in the pull down menu **Functions** or in the toolbar menu. The order of the menus mirrors that of the procedure for configuring and starting measurements.

F req ▶	Selecting the frequency span (setting the x axis in the diagram area)
A mp ▶	Setting the level axis and the RF input (setting the y axis in the diagram area)
M arker ▶	Signal analysis with marker functions
BW/S weep ▶	Setting the bandwidths and the sweep time
T race ▶	Displaying the trace
T rigger ▶	Triggering the measurement
M easure ▶	Measurement functions

7.6.2.1 FREQ Menu

Main function display (always visible)

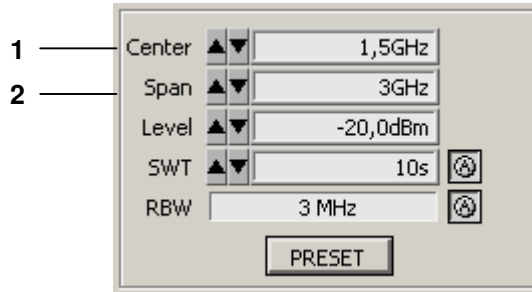

Function display (insert with F5 key)

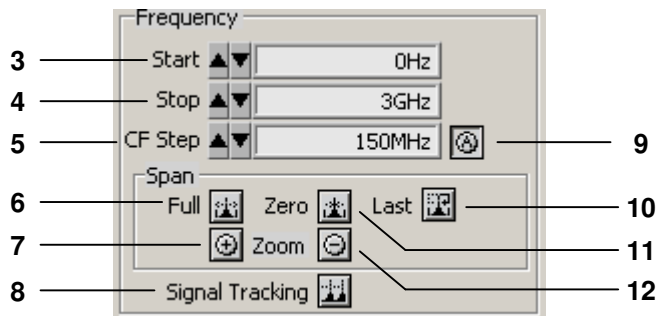

Function and shortcut

Center	Ctrl+Shift+C	Entering the center frequency	(1)
Span	Ctrl+Shift+S	Entering the span	(2)
Start	Ctrl+Shift+B	Entering the start frequency	(3)
Stop	Ctrl+Shift+E	Entering the stop frequency	(4)
Center Stepsize	▶	Open submenu: Entering the step width of the center frequency	
manual		Setting the step size manually	(5)
auto		Setting the step size automatically	(9)
= Centerfrequency		Setting the step size to the center frequency	
= Markerfrequency		Setting the step size to the marker frequency	
Span Settings	▶	Open submenu: Display modes for the frequency axis	
Full Span		Displaying the whole frequency range	(6)
Zero Span		Switching over to the ZERO SPAN	(11)
Last Span		Restoring the previous setting	(10)
Zoom In	Ctrl++	Reducing the span	(7)
Zoom Out	Ctrl+-	Increasing the span	(12)
Signal Tracking	▶	Open submenu: Signal tracking	
on		Activating signal tracking	(8)
off		De-activating signal tracking	(8)

7.6.2.2 Amp Menu

Main function display (always visible)

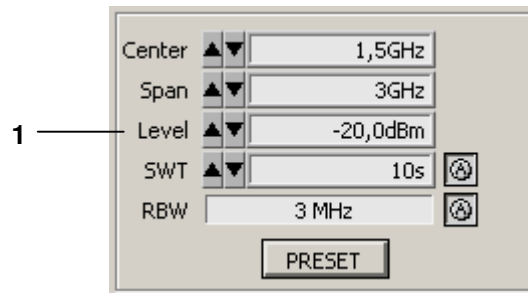

Function display (insert with F6 key)

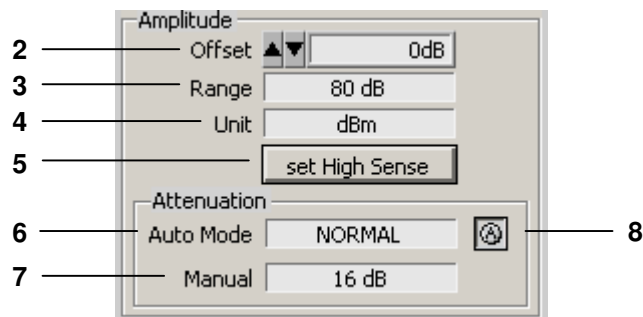

Function and shortcut

Ref <u>L</u> ev <u>e</u> l	Ctrl+Shift+L	Entering the reference level	(1)
Ref Level <u>O</u> ffset		Entering a level offset	(2)
<u>R</u> ange	Ctrl+Shift+R	Selecting the level display range	(3)
<u>U</u> nit	Ctrl+Shift+U	Selecting a unit for the level display	(4)
Set High Sense		Setting the high sensitivity automatically	(5)
RF <u>A</u> ttenuation		Setting the RF input attenuation manually	(7)
RF Attenuation <u>A</u> uto		Setting the RF input attenuation automatically	(6), (8)

7.6.2.3 Marker Menu

Function display
(insert with F7 key)

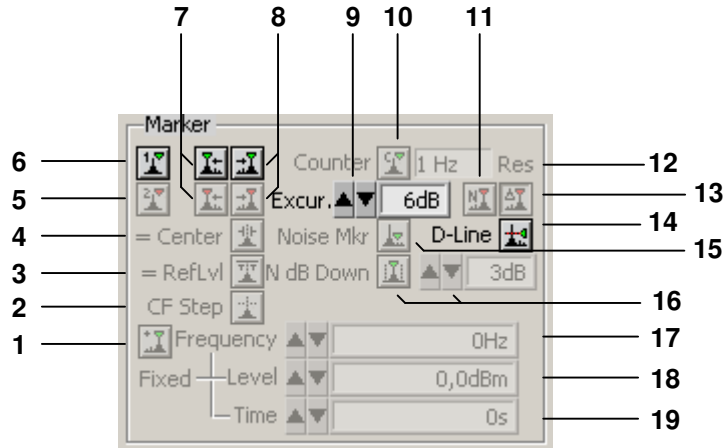

Function and
shortcut

Marker 1	▶	Open submenu: Activate marker 1		
Peak	Ctrl+Shift+M	Place marker 1 on the trace maximum		(6)
next Peak left		Place marker 1 on the next trace maximum to the left		(7)
next Peak right		Place marker 1 on the next trace maximum to the right		(8)
Signal Count		Measure the signal frequency: Start measurement		(10)
Signal Count Resolution		Measure signal frequency: Set resolution		(12)
off		De-activate marker 1		(6)
Marker 2	▶	Open submenu: Activate marker 2		
Peak		Place marker 2 on the trace maximum		(5)
next Peak left		Place marker 2 on the next trace maximum to the left		(7)
next Peak right		Place marker 2 on the next trace maximum to the right		(8)
Marker norm		Set marker 2 as a normal marker (NORM)		(11)
Marker delta		Set marker 2 as a delta marker (DELTA)		(13)
off		De-activate marker 2		(5)
Marker >	▶	Open submenu: Accepting marker values as settings		
Center = Marker Freq		Set the center frequency to the marker frequency		(4)
Ref Level = Marker Level		Set the marker level as a reference level		(3)
Center Stepsize = Marker Freq		Set the step size for entering the center frequency to the marker frequency		(2)

Marker Functions	▶	Open submenu: Marker measurement functions	
	Noise Marker	Measuring noise power density	(15)
	n dB down	Measuring signal bandwidth	(16)
D-Line	Ctrl+Shift+D	Bring display line up on screen	(14)
Limit Line		Bring limit line up on screen	(↗ 7-249)
Ref fixed	▶	Open submenu: Reference points for measuring level differences	
	on	Activating the entry of arbitrary reference points	(1)
	off	Using M1 marker values as a reference point	(1)
	Ref Point Level	Entering the reference-point level	(18)
	Ref Point Freq	Entering the reference-point frequency	(17)
	Ref Point Time	Entering the reference-point time	(19)
Marker Settings	▶	Open submenu: Search criterion of functions NEXT PEAK LEFT/RIGHT	
	Peak Excursion	Entering the peak excursion	(9)

7.6.2.4 BW/Sweep Menu

Main function display (always visible)

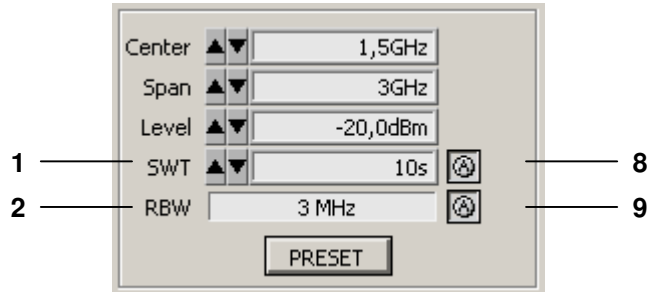

Function display (insert with F8 key)

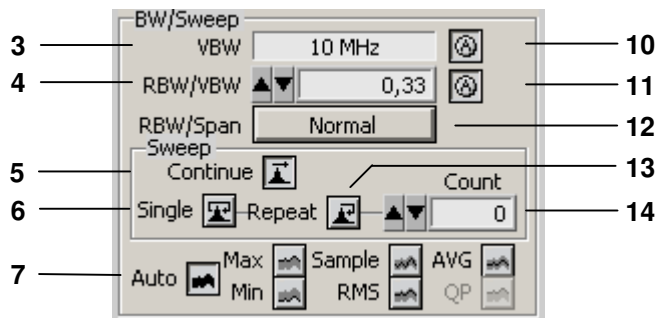

Function and shortcut

Res BW manual Ctrl+Shift+W	Setting the resolution bandwidth manually	(2)
Res BW auto	Activating automatic resolution bandwidth setting	(9)
Video BW manual	Setting the video bandwidth manually	(3)
Video BW auto	Activating automatic video bandwidth setting	(10)
Coupl Ratio ▶	Open submenu: Setting the RBW/VBW coupling ratio	
RBW/VBW manual	Setting the coupling ratio manually	(4)
RBW/VBW auto	Activating the default setting for the coupling ratio	(11)
Sweep ▶	Open submenu: Setting the sweep time	
Cont Sweep Ctrl+!	Starting a continuous frequency sweep	(5)
Single Sweep Ctrl+"	Performing an n-times sweep	(6)
No. of Sweeps	Setting the number of sweeps	(14)
Repeat Single Sweep	Repeating n-times sweeps	(13)
Sweep time manual	Setting the sweep time manually	(1)
Sweep time auto	Activating automatic sweep-time setting	(8)
RBW/Span Low Noise	Changing automatic resolution bandwidth setting	(12)
Normal	Automatic RBW limits for normal sensitivity	
Low Noise	Automatic RBW limits for maximal sensitivity	

Detector	▶	Open submenu: Setting the detector	
Max Peak		PEAK detector is active	(7)
Min Peak		MIN PEAK detector is active	(7)
Sample		SAMPLE detector is active	(7)
RMS		RMS detector is active	(7)
AVG		AVERAGE detector is active	(7)

7.6.2.5 Trace Menu

Function display
(insert with F9 key)

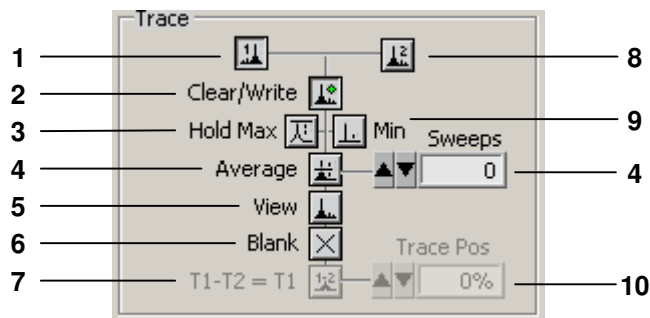

Function and
shortcut

Select Trace	▶	Open submenu: Selecting the active trace	
Trace <u>1</u>		Turning on and activating Trace 1	(1)
Trace <u>2</u>		Turning on and activating Trace 2	(8)
C <u>l</u> ear/W <u>r</u> ite		Trace display mode: Overwrite mode	(2)
M <u>a</u> x H <u>o</u> ld		Trace display mode: Max. hold	(3)
M <u>i</u> n H <u>o</u> ld		Trace display mode: Min. hold	(9)
T <u>r</u> ace <u>A</u> verage		Trace display mode: Averaging	(4)
V <u>i</u> ew		Freezing the trace	(5)
B <u>l</u> ank		Blanking out the trace	(6)
M <u>a</u> th	▶	Open submenu: Trace difference	
T <u>1</u> -T <u>2</u> =>T <u>1</u>		Turning on the trace-difference mode	(7)
T <u>r</u> ace <u>P</u> os		Repositioning Trace 1 (result)	(10)
o <u>ff</u>		Turning off the trace-difference mode	(7)

7.6.2.6 Trigger Menu

Function display
(insert with F10 key)

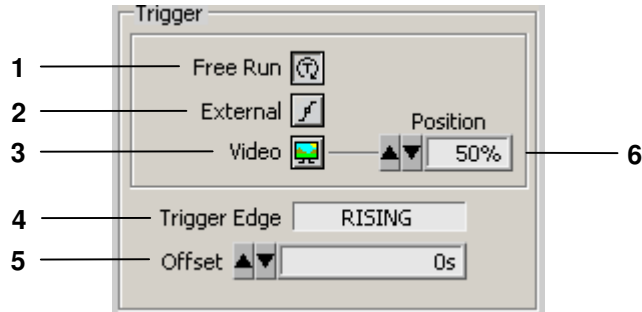

Function and
shortcut

Free Run	Free-running measurements	(1)
External	Triggering by an external TTL signal	(2)
Video	Triggering by the display level	(3), (6)
Edge	Setting the trigger edge	
	RISING	Triggering on positive-going edge (4)
	FALLING	Triggering on negative-going edge (4)
Offset	Entering a trigger offset	(5)



Note

The trigger function **LINE** (triggering by the AC-line frequency) is not supported.

7.6.2.7 Measure Menu

Function display
(insert with F11 key)

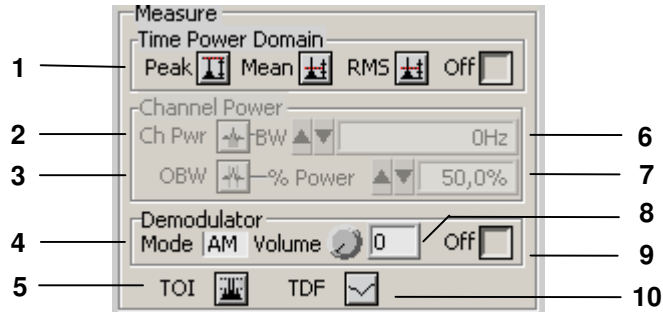

Function and
shortcut

Time Power Domain	▶	Open submenu: Measure the power in the time domain (ZERO SPAN)	
Peak		Output the peak value within the section	(1)
Mean		Output the mean value within the section	(1)
RMS		Output the rms value within the section	(1)
		Marker T1 in the measuring diagram	Moving the vertical line to limit the lower (left) part of a section
		Marker T2 in the measuring diagram	Moving the vertical line to limit the upper (right) part of a section
off		Switch off the power measurement	(1)
Channel Power	▶	Open submenu: Measuring the channel power and the occupied bandwidth	
Channel Power		Measure the channel power	(2)
Channel Power Bandwidth		Set the channel bandwidth	(6)
Occupied Bandwidth		Measure the occupied bandwidth	(3)
%Power Bandwidth		Set the power bandwidth	(7)
Demodulator	▶	Open submenu: AM/FM demodulation	
Mode		Select the AM/FM demodulation mode	(4)
Volume		Adjust the headphone volume	(8)
RBW in MAIN function display		Set the demodulation bandwidth	
off		Switching off the AM/FM demodulation	(9)
TOI		Measure the third-order intercept point	(5)
Transducer		Activating the transducer function	(10), (↗ 6-164)

Function display
(insert with TG key)

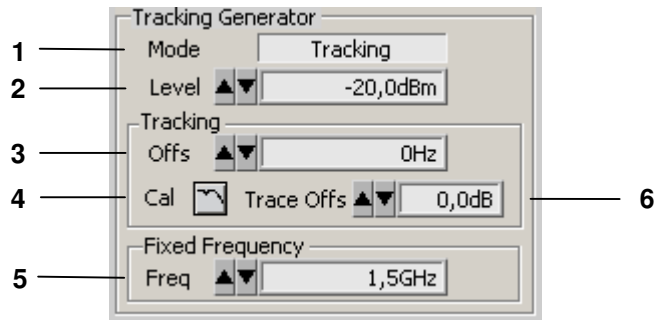

Function and
shortcut

Tracking Generator ▶

Open submenu:

Configuring the built-in generator

Level	Enter the output level	(2)
Frequency	Enter the frequency or enter the frequency offset (Tracking Generator)	(5)
Cal Transm	Calibrate the test setup and activate the calibration	(4)
Ref Position	Enter the reference position	(3)
Trace Offset	Enter the level offset	(6)
Mode	Select the tracking generator operating mode	(1)

7.6.3 View

Menus for configuring the program interface

Menus for resizing the window and setting screen colors are available in the pull-down menu **View**.

large Window	Ctrl+W	Switch on/off large window	(↗ 7-266)
Color	Ctrl+L	Set screen color	(↗ 7-267)

7.6.4 ? Help

Help menus

Menus for opening the help function and displaying the program information are available in the pull-down menu **Help**.

Help		Start help function	(↗ 7-268)
Info	Ctrl+I	Display program information	(↗ 7-268)
Service		Displaying module data and performing the selftest	(↗ 7-269)

7.6.5 Zoom Functions

Diagram area
(always visible)

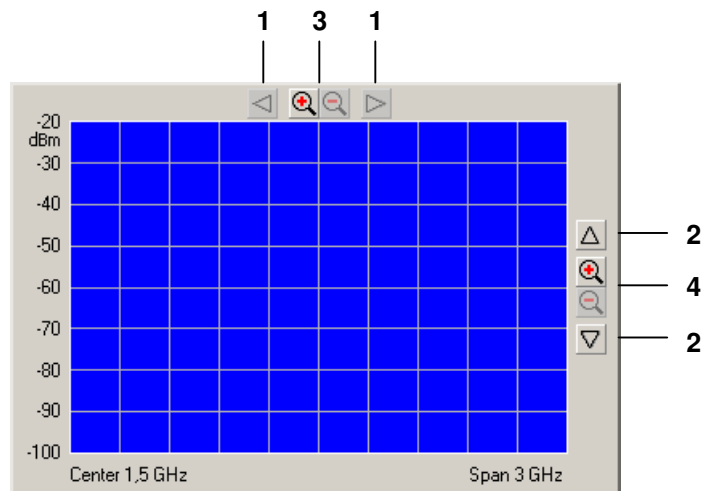

Functions

- Zoom** Zoom the screen window
- (1) Move screen window in X direction (one grid unit)
 - (2) Move screen window in Y direction (one grid unit)
 - (3) Zoom screen window in/out in X direction
 - (4) Zoom screen window in/out in Y direction

 **Note**

Zoom function (3) corresponds to the Zoom In/Out functions (↗ 7-236).
Zoom function (4) corresponds to the Range functions (↗ 7-237).

7.7 Saving/Exporting Data (File)

7.7.1 Opening the Session

Application

A new session is opened automatically when the program is started (↗ 7-217). The current R&S FS315 settings are loaded. The following settings are display and evaluation functions and are not transferred to the PC software:

- Marker functions (↗ 7-238)
- Scale of measuring diagram (Range, Unit)
- Trace functions (↗ 7-241)
- Measure functions (↗ 7-243)

However, you may also open a new session while in remote control mode. Default settings are automatically loaded (↗ 6-70).

You can save and load specific instrument settings if you plan to work with these on a regular basis.

7.7.1.1 Beginning New Measurement

Beginning the measurement with current instrument setting

- Start the PC software on your PC.



Beginning the measurement with factory setting

- Select menu item: **New**.

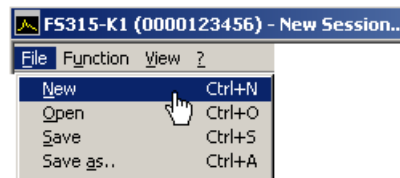

7.7.1.2 Loading the Saved Settings

Note

If you drag and drop an *.fs file (saved instrument settings) to the FS315-K1.exe icon while the program is closed, the program will open using the settings from this *.fs file.

Beginning the measurement with saved instrument settings

1. Select menu item: **Open**.

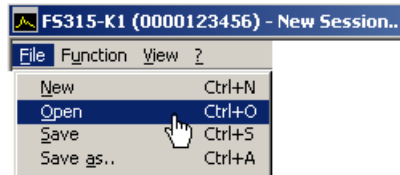

2. Select a file from the directory and click **<Open>**.

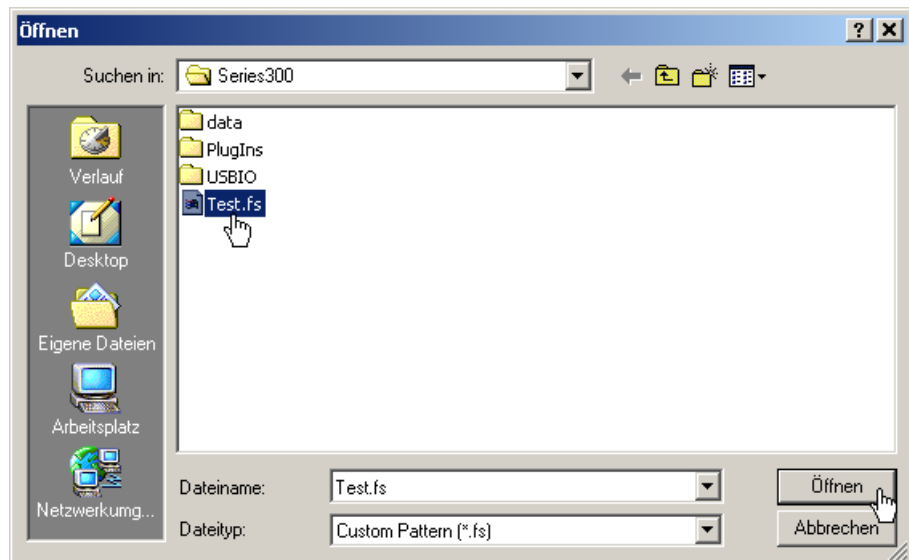

Resetting the instrument settings

- To load the instrument settings that were last loaded or the factory settings, press **<Preset>** in the main function display.



7.7.2 Saving the Session

Application

You can save specific instrument settings if you plan to work with them on a regular basis (Save Session).

You may also change a previously saved instrument setting and save it under a different file name (Save Session as..).

Saving instrument settings

1. Select menu item: **Save** or **Save as...**

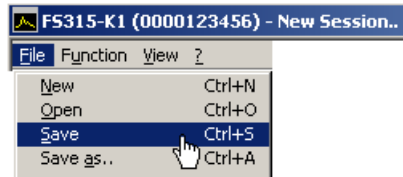

2. Select a directory, enter a file name and click **<Save>**.

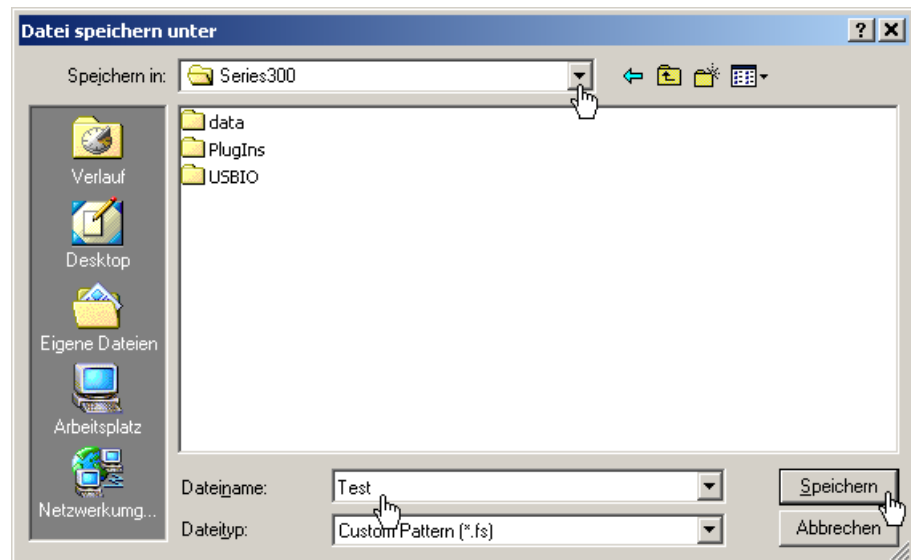

7.7.3 Monitoring the Measuring Values

Introduction If you wish to monitor deviation of measuring values you may set limit lines (Limit Lines) to monitor them. A logfile is created which can be opened with any text editor or with Microsoft Excel™.

7.7.3.1 Inserting the Limit Lines

Application Measuring values which **overshoot** the limit lines are monitored with an **Upper Line** and measuring values which undershoot the limit lines are monitored with a **Lower Line**. The shape of the limit lines are entered into a table in value pairs (frequency, amplitude), they may then be inserted into the measuring diagram.

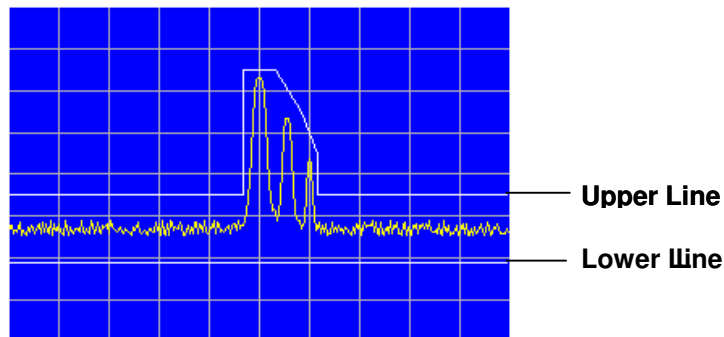

You can create limit lines with up to 50 value pairs, these may be saved and loaded for later use.

Entering limit lines

1. Select menu item: **Limit Line**.

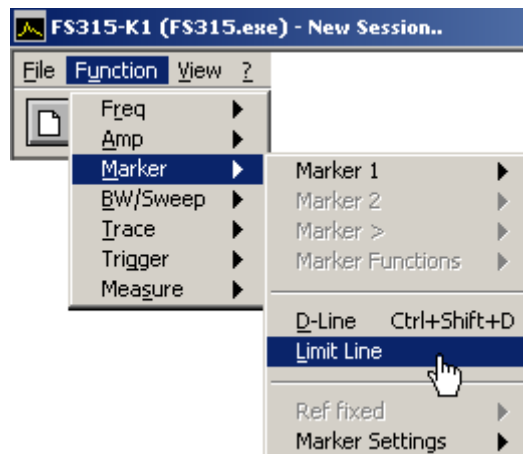

Edit Limit Lines window opens.

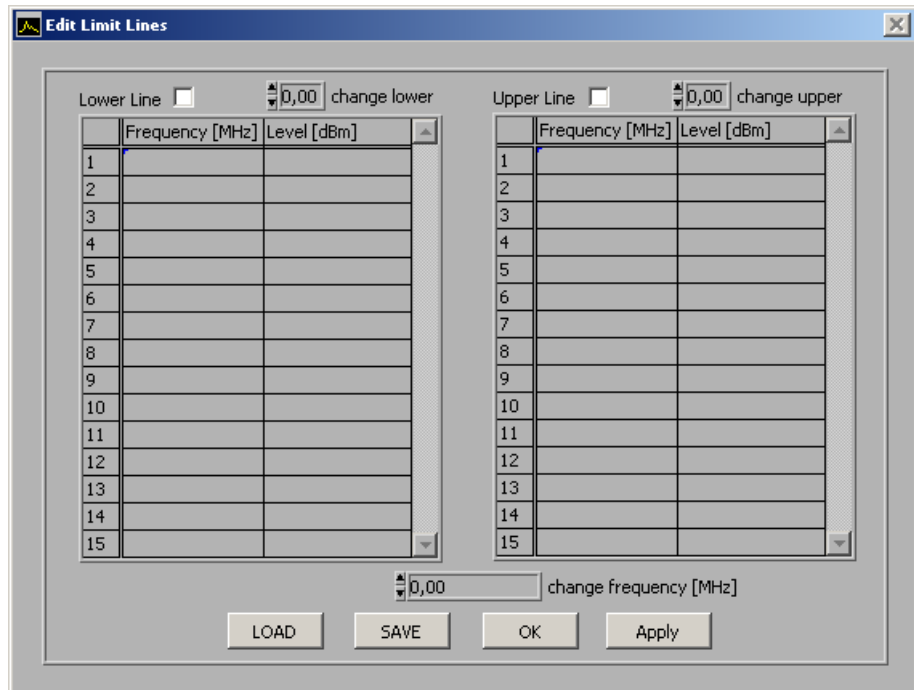

- Use the left-hand table to enter the frequency and amplitude values for the **Lower Line** and use the right-hand table to enter the **Upper Line**. Each row in the table describes a reference point on the limit line. At least 2 value pairs (reference points) per line must be entered, e.g., lower line: -80 dB for full span.

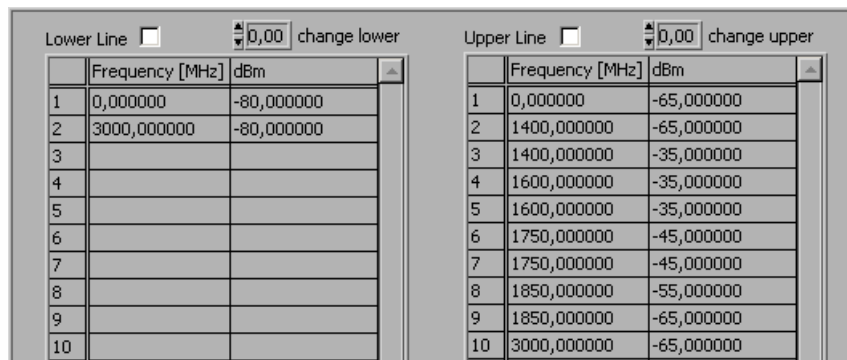

Note: You may increase and decrease the amplitude values of a limit line for all value pairs with the input fields: **change lower/change upper**.

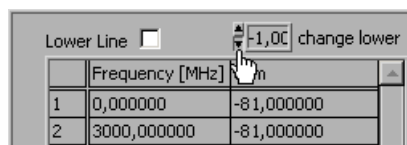

You may increase and decrease the frequency values of a limit line for all value pairs with the input fields: **change frequency [MHz]**.

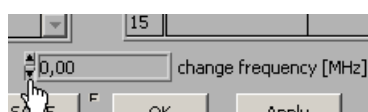

Inserting limit lines

1. Tick the check boxes for **Lower Line** and/or **Upper Line** to activate the limit line(s).

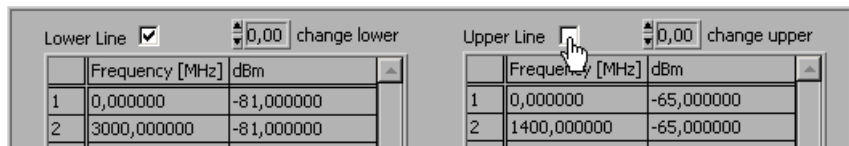

2. Click **<APPLY>** to activate the limit line(s). The status information **Upp** and/or **Low** are displayed in the diagram.

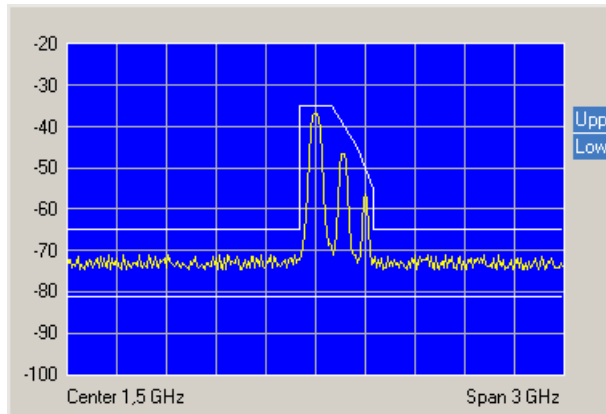

Saving and loading limit lines

1. Press **<SAVE>** if you plan to use the current settings again.



The **Save File as** window opens.

2. Select a directory, enter a file name and click **<Save>**. The current settings are saved.
3. Press **<LOAD>** if you wish to use the saved settings again.

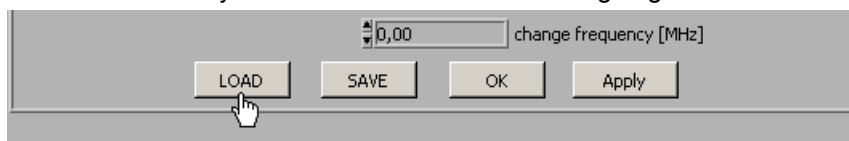

The **File open** window opens.

4. Select the **(.lim)** file from your directory and click **<Open>**. The saved settings (frequency and amplitude values) are loaded.
- Press **<OK>** to close the **Edit Limit Lines** window. The current settings remain active in the diagram.

Closing the window

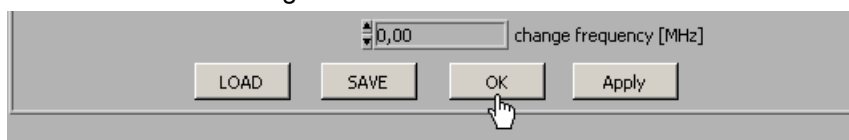

7.7.3.2 Monitoring

Aim A logfile is created during the monitoring process, which documents over- and undershooting of a limit line. This allows random events to be captured.

Creating the logfile 1. Select menu item: **Logfile**.

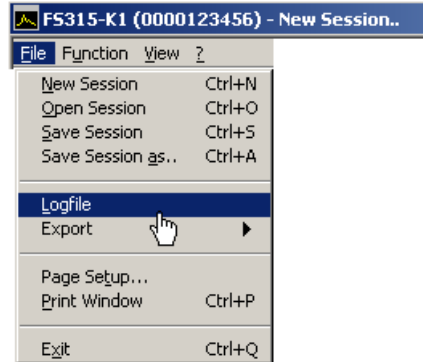

The **Logfile** window opens.

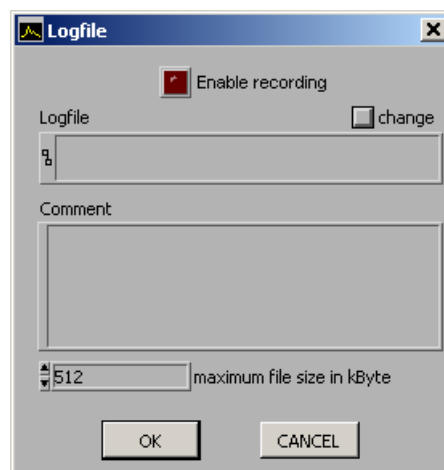

2. Click **<change>** if a logfile has not yet been created.

The **Save File as** window opens. Select a directory, enter a file name and click **<Save>**. The current logfile path is displayed.

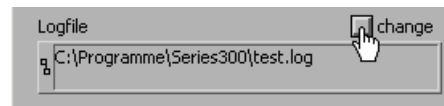

3. Click in the **Comment** window to enter a logfile comment.



Starting the monitoring

1. Enter the maximum logfile memory size in KB. The default setting is "512 KB".



2. Click **<Enable recording>** to start the monitoring process. The button lights up red.



If an over- or undershoot of a limit is detected, the corresponding status information **Upp** and/or **Low** flashes in the diagram. The measuring values are monitored 10x per second and each over- or undershoot of a limit line is recorded.

Stopping the monitoring

1. Click **<Enable recording>** to finish the monitoring process. The button no longer lights up red.
2. Click **<OK>** to close the **Logfile** window.



7.7.3.3 Analyzing the Logfile

Logfile content

The logfile contains the measuring data, which were recorded during the monitoring process. A record is created from the following parameters when a limit line has been over- or undershot.

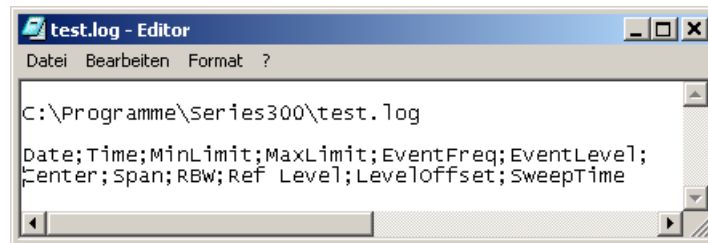

- **Date** - event date
- **Time** - event time
- **MinLimit (1)** - limit line level Upp
- **MaxLimit** - limit line level Low
- **EventFreq (2)** - event frequency value
- **EventLevel (3)** - event maximum level
- **Center** - center frequency
- **Span** - span
- **RBW** - resolution bandwidth
- **Ref Level** - reference level
- **Leveloffset** - level offset
- **SweepTime** - sweep time

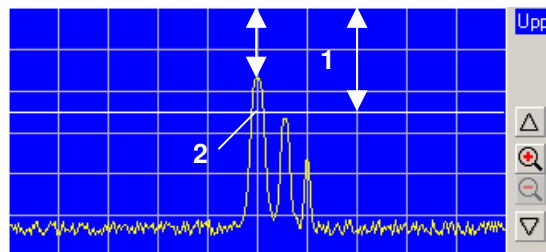

Analyzing the logfile

If the logfile (.log) is saved as a text file (.txt) the data can be opened and analyzed in Microsoft Excel™.

7.7.4 Exporting the Measuring Data

Application To record the measurements, you can save the current diagram with the most important parameter settings in ASCII code or you can save a screenshot of the current window as a JPEG.

7.7.4.1 Creating the ASCII File

Creating the ASCII file

1. Select menu item: **ASCII file**.

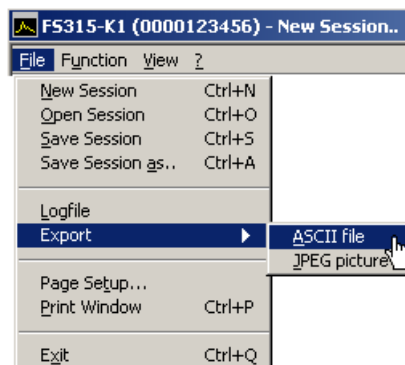

The **Export ASCII** window opens.

2. Click in the **Please change comment** window to enter a logfile comment and click **<OK>**.

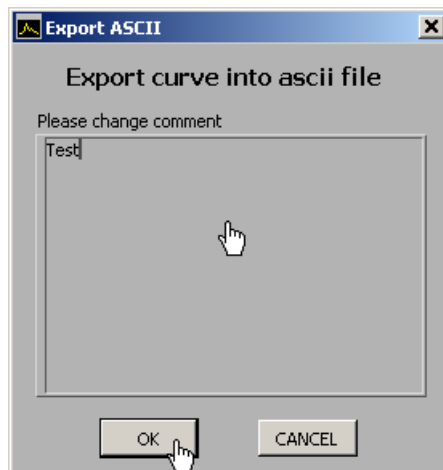

The **Save File as** window opens.

3. Select a directory, enter a file name and click **<Save>**.

ASCII File contents

The ASCII file contains the following parameters:

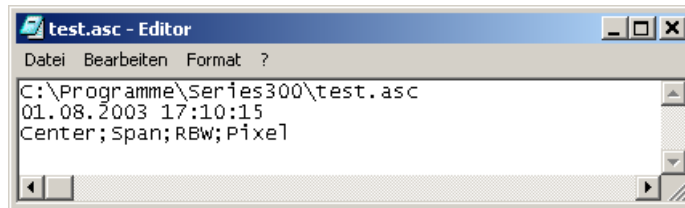

- **Center** - center frequency
- **Span** - span
- **RBW** - resolution bandwidth
- **Pixel** - level values of the trace

**Note**

The number of exported level values (pixels) depends on the setting for the size of the window. (↗ 7-266, small window: 310 pixels, large window: 700 pixels)

7.7.4.2 Creating the Screenshot

Creating the screenshot

1. Select menu item: **JPEG picture**.

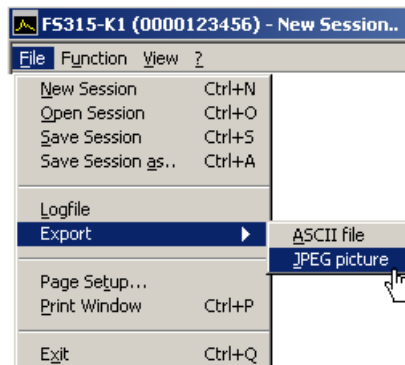

The **Save File as** window opens.

2. Select a directory, enter a file name and click **<Save>**.

7.7.5 Printing the Window

Page setup

1. Select menu item: **Page setup**.

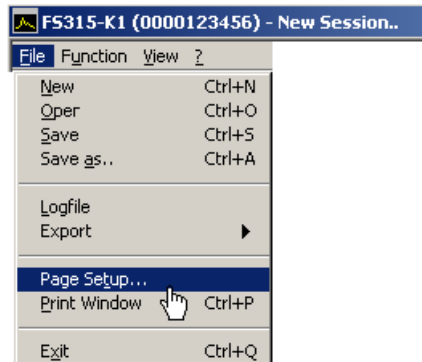

The **Page setup** opens.

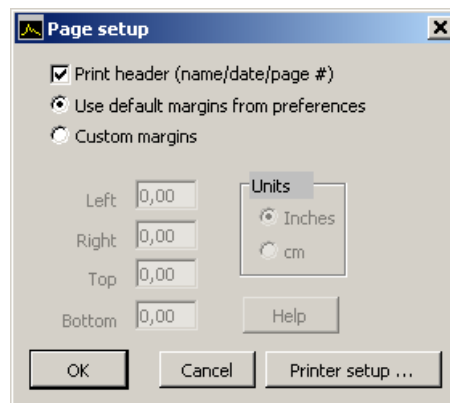

2. Check the **<Print header>** box (✓) to print a header with the file name, date and page number.
 3. Check **<Use default margins from preferences>** to print page with the presettings.
You may also check **<Custom margins>** to print page with user-defined settings. You may then adjust the page margins: **<Left>**, **<Right>**, **<Top>** and **<Bottom>**.
 4. Click **<Printer setup>** to select your printer settings.
 5. Click **<OK>** to close the **Page setup** window.
- Printing the window**
6. Select menu item: **Print Window** from the **File** pull-down menu to print the current program window.

7.8 Transducer Factors

Use

Antenna factors (transducer factors) are necessary to allow the field strength received using an antenna to be displayed on a spectrum analyzer with the correct level.

Antenna factors are supplied by the antenna manufacturers in the form of calibration reports or as simple ASCII or text files.

Antenna factors are specified at various reference points across the frequency range. The values are interpolated linearly between the reference points. Depending on which unit is used for the antenna factors, calculation is performed based on the respective basic unit. If the values are returned referred to $\text{dB}\mu\text{V}$, the antenna factors are added to the trace scaled in $\text{dB}\mu\text{V}$.

Calling up entry window

1. Select the **Transducer** menu item.

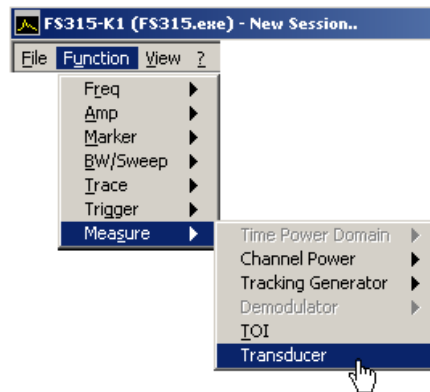

The **Transducer Factor** entry window is opened.

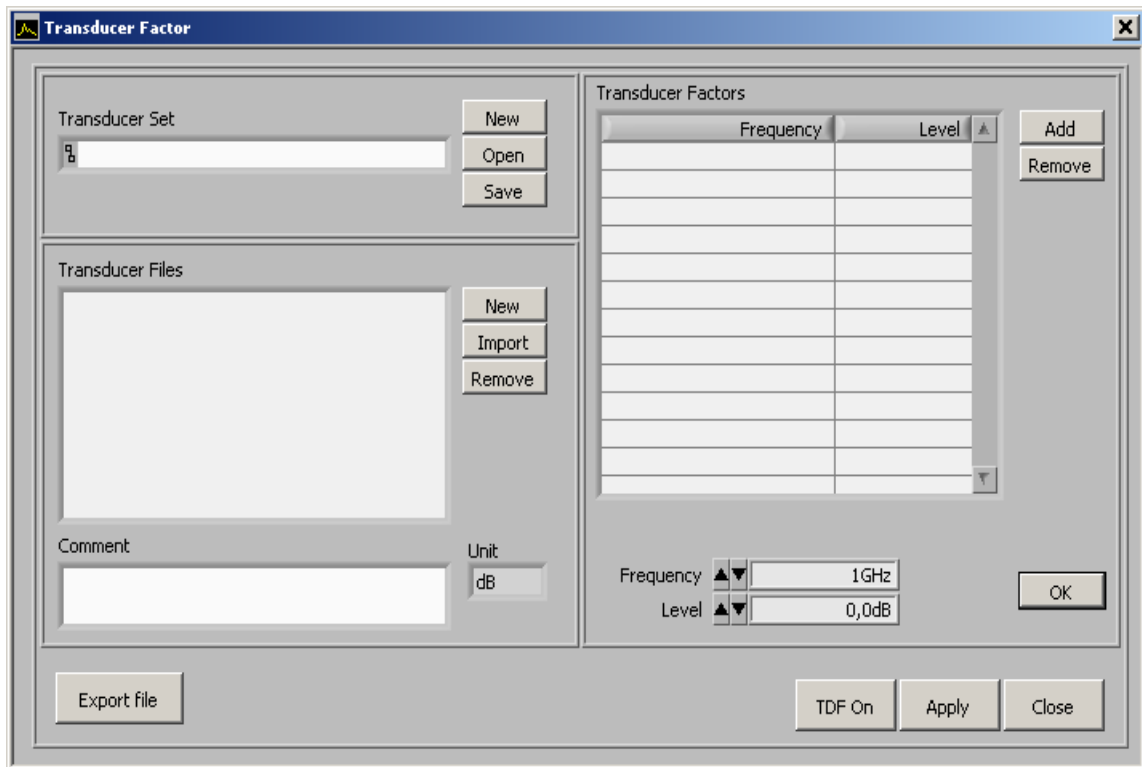

Meaning of buttons and entry fields

Transducer Set

- <New> Creating transducer set
- <Open> Opening transducer set
- <Save> Saving transducer set

Transducer Files

- <New> Creating transducer list
- <Import> Importing transducer list
- <Remove> Deleting transducer list
- Unit** Selecting unit of the transducer list
- Comment** Editing a comment for transducer list

Transducer Factors

- <Add> Adding transducer factor
- <Remove> Deleting transducer factor
- <Frequency> Editing frequency value of transducer factor
- <Level> Editing level value of transducer factor
- <OK> Quitting entry of transducer factor
- <Export File> Saving transducer factors on USB stick
- <TDF On> Activating transducer factors in the PC software R&S FS315-K1
- <Apply> Updating switched transducer factors
- <Close> Closing entry window

7.8.1 Creating Transducer List

Use Antenna factors will be supplied in calibration certificates on paper or electronically as ASCII-files by the antenna manufacturers.

They specify discrete level correction values over the frequency range of the antenna. For frequencies not included in the correction list, level correction values are determined by linear interpolation. The unit of the antenna factors determines the level unit in the R&S FS315.

You can create new transducer lists. The PC software R&S FS315-K1 allows you to save a comment with every transducer list.

Creating transducer list

1. Click on **<New>** in the field **Transducer Files**.
A new transducer-list will be created, e.g. "created file 0".

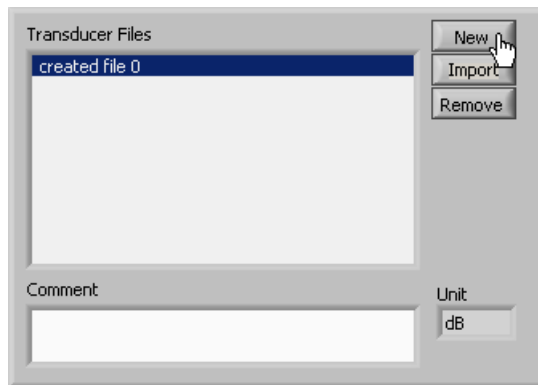

2. Set the unit of the transducer factors by clicking on the selection window **Unit** in the **Transducer Files** field.

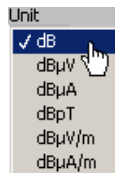

3. Add a **Comment** by clicking on entry field **Comment** in the **Transducer Files** field.



Editing transducer factors

1. Click on **<Add>** in the field **Transducer Factors**.
A new line (correction value) will be created in the transducer list.
2. Click repeatedly on **<Add>** to create the wished number of correction values.

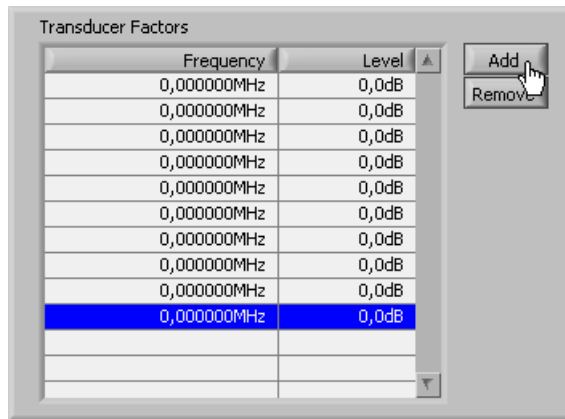

3. Click in the field **Transducer Factors** on the line you want to edit.
The cursor jumps to the entry field **Frequency**.

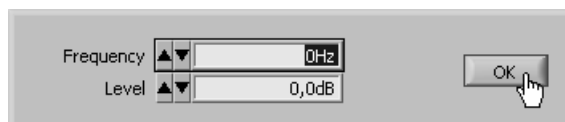

4. Enter a new value.
The entry range for the **Frequency** is:
0 Hz ≤ Frequency ≤ 3 GHz
5. Press the **Tab** key.
The cursor jumps to the entry field **Level**.
6. Enter a new value.
The entry range for the **Level** is:
0 dB(x) ≤ Level ≤ 100 dB(x)
7. Click on **<OK>** in the **Transducer Factors** field to complete the input.
The transducer list will be updated and the entries will be sorted by the frequency values.
Note: Press **Enter** key will also complete the input.
8. If you like to remove a correction factor from the list click on the respective line in in the **Transducer Factors** list. Click on **<Remove>** to delete the entry.
The transducer list will be updated.

Saving transducer list

1. Click on **<Save>** in the field **Transducer Set**.
The window **Save File** will be opened.
2. Choose a Directory and type in the file name. Click on **<Save>**.
The transducer list will be saved (*.tds)

Importing transducer list

1. Click on **<Import>** in the field **Transducer Files**.
The window open file will be opened.
2. Select the text file with the transducer factors in the directory and click on **<Open>**.
The imported transducer list will be loaded.

Deleting transducer list

- Select the correction factor in the **Transducer Files** you want to delete and then click on **<Remove>**.
The selected transducer list will be removed.

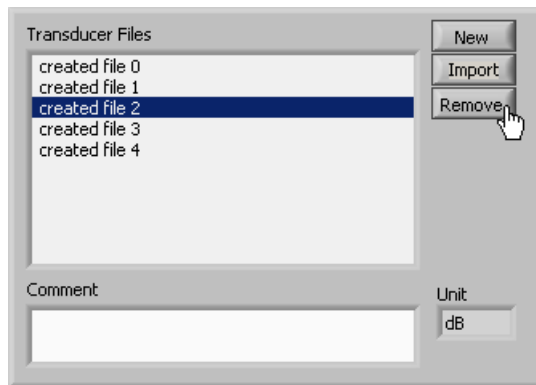

7.8.2 Creating Transducer Set

Use

In addition to the antenna factors, it is also possible to take the damping factor of a cable or the gain of an amplifier into consideration.

A complete system can consist of several components (up to 10 transducer lists) for which a cumulative correction factor (transducer set) is calculated.

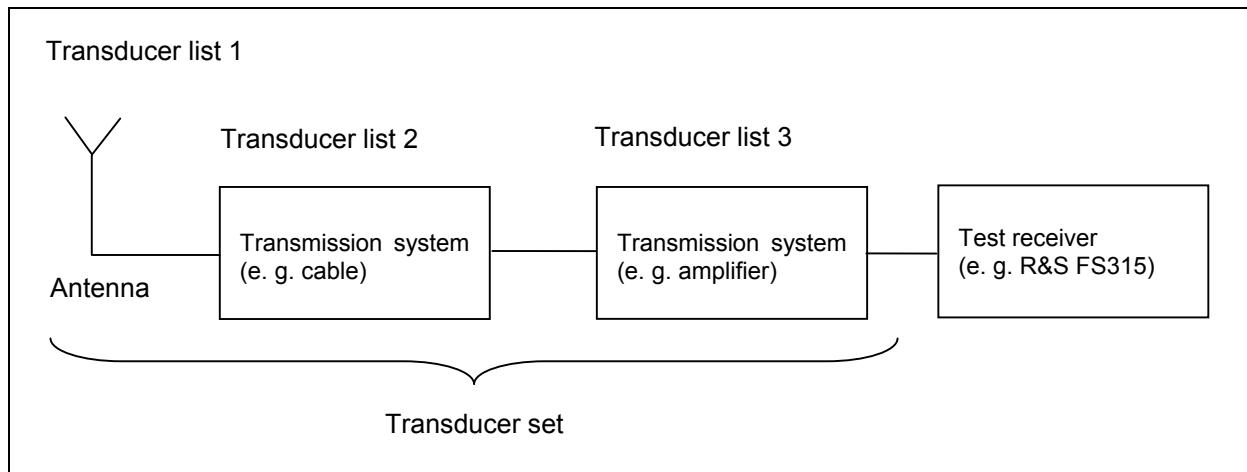

The following combinations of units are possible in a transducer set:

	$\text{dB}\mu\text{V}/\text{m}$	$\text{dB}\mu\text{A}/\text{m}$	$\text{dB}\mu\text{V}$	$\text{dB}\mu\text{A}$	dBpT	dB
$\text{dB}\mu\text{V}/\text{m}$	-	-	-	-	-	√
$\text{dB}\mu\text{A}/\text{m}$		-	-	-	-	√
$\text{dB}\mu\text{V}$			-	-	-	√
$\text{dB}\mu\text{A}$				-	-	√
dBpT					-	√
dB						√

The transducer lists can have different start and end points and different numbers of reference points. The number of resulting reference points is based on the transducer list with the most reference points.

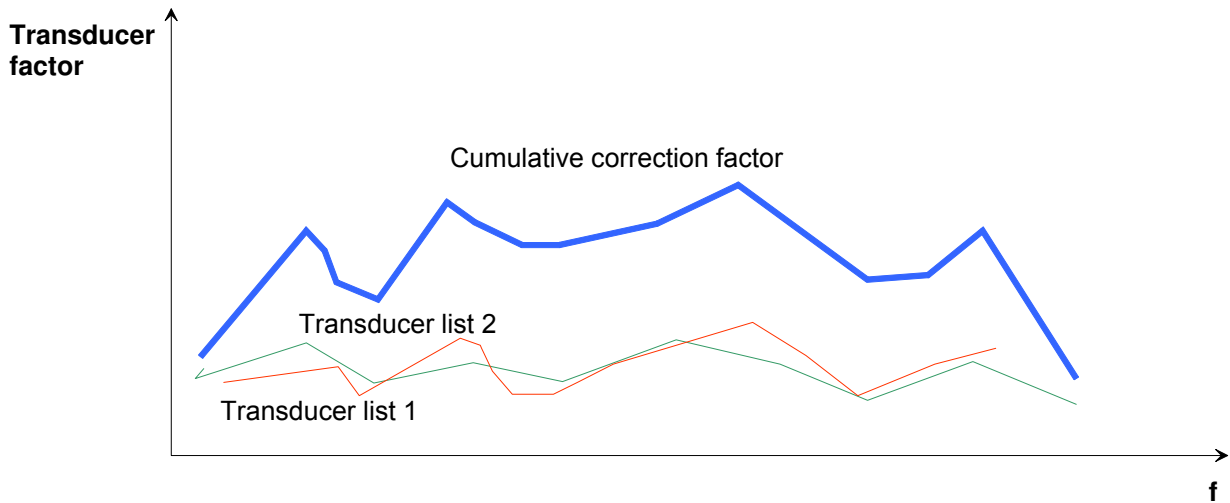

You can create new transducer sets and load and edit existing transducer sets. The save function saves all information from the transducer set.

Only the cumulative correction factor is used when a transducer set is transferred to the R&S FS315 from a USB stick.

Creating transducer set

1. Click on **<New>** in **Transducer Set**.

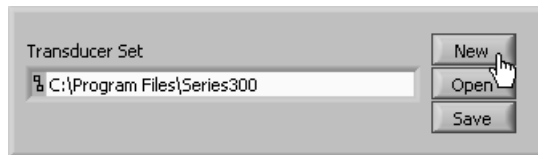

2. Click on **<Import>** in **Transducer Files** and load the required transducer lists.



3. If necessary, adapt the selected transducer list (↗ 7-261).

Saving transducer set

1. Click on **<Save>** in **Transducer Set**.
The **Save File As** entry window is opened.
2. Select the directory to which you want to save the file, enter a file name and click on **<Save>**.
The current transducer lists are saved as a transducer set.

Loading transducer set

1. Click on **<Open>** in **Transducer Set**.
The **Open File** entry window is opened.
2. Select the file (**.tds**) in the directory in which it is saved, and then click on **<Open>**.
The saved transducer sets are loaded.

7.8.3 Activating Transducer Factors

Use

The transducer factors and transducer sets are calculated and edited using the PC software R&S FS315-K1. If the R&S FS315 is remote-controlled from the PC, the selected transducer set is applied directly to the displayed trace.

You can also use a USB stick to load/save transducer sets to/from the R&S FS315 (➤ 6-164). However, it is not possible to edit a transducer set on the instrument.

Activating/ deactivating trans- ducer factors

1. Click on **<TDF On>**, to activate the transducer factors in the PC software R&S FS315-K1.

The button is highlighted.



During the sweep, the values from the active transducer list are added to the result of the level measurement. The correction values are recalculated if the display range is changed. If an activated transducer list is not defined across the entire sweep range for the measurement, the missing values are replaced by zero.

The selected level unit is determined by the transducer list and cannot be changed in the AMPT menu.

2. Click on **<Apply>** to update the transducer factors in the PC-Software R&S FS315-K1.

Changes in the transducer list do not have an immediate effect on measurement curve in the PC-Software R&S FS315-K1. The button **<Apply>** will cause that the measurement curve is updated with new transducer factors.

3. Click on **<Activate TDF>** to deactivate the transducer factors.

The button is no longer highlighted.

The transducer factors no longer influence the displayed trace and the level unit can be changed again.

Saving transducer factors on USB stick

1. Connect a USB stick to the PC.
2. Click on **<Export File>** to save the current transducer set on the USB stick.

The cumulative correction factor of all loaded transducer lists is saved on the USB stick. The source information is not supplied. The PC software R&S FS315-K1 cannot therefore be used to re-edit this file (*.tdf).

Closing entry win- dow

- Click on **<Close>** to close the entry window.

7.9 Customizing the Working Window (View)

7.9.1 Adjusting the Window Size

Adjusting the window size

1. Select menu item: **Large Window** to enlarge the program window.

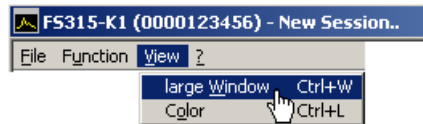

The diagram is enlarged by a factor of 2. In addition to the **Main Settings**, two function displays appear in the function display area. The first function display (e.g., **Amplitude**) refers to the current menu selection and the second function display (e.g., **Trace**) refers to the last menu selection.

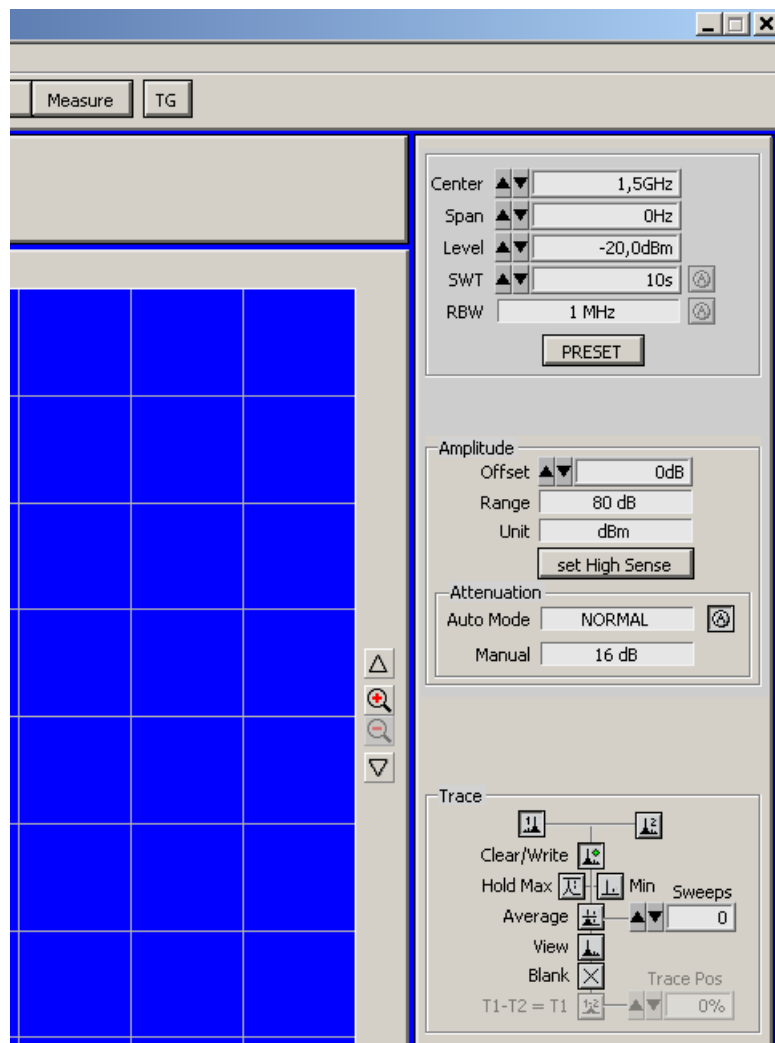

2. Select the **Large Window** menu item again to reduce the window size.

7.9.2 Changing the Window Color

Changing the window color

1. Select menu item: **Color**.

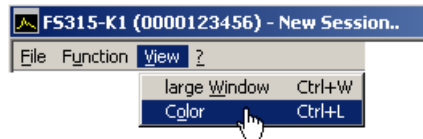

The **Screen Color** window opens. Colors for the listed window elements can be changed.

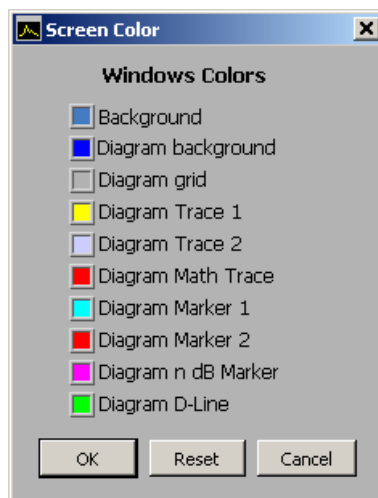

2. Click on a color field to change the color for the corresponding windows element. A color scheme opens.



3. Move the mouse over the color bars and click on your preferred color. The color scheme closes and the new color appears in the color field of the window element.
4. Click **<OK>** to close the **Screen Color** window and to activate the new window colors.

You may also click **<Reset>** and **<OK>** to revert to the default color settings.

7.10 Getting Help (?)

7.10.1 Starting the Help

Starting the help

- Select menu item: **Help** to start the Windows™ Help for program **FS315 0000xxxxxx**.

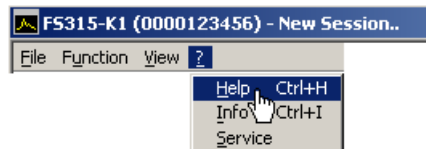

Acrobat Reader™ (↗ CD-ROM) starts up and the English R&S FS315 operating manual opens.

7.10.2 Displaying the Program Version

Opening/closing the program version

1. Select menu item: **Info** for information about the **FS315 0000xxxxxx** program.

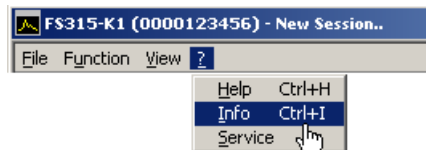

An information field opens.

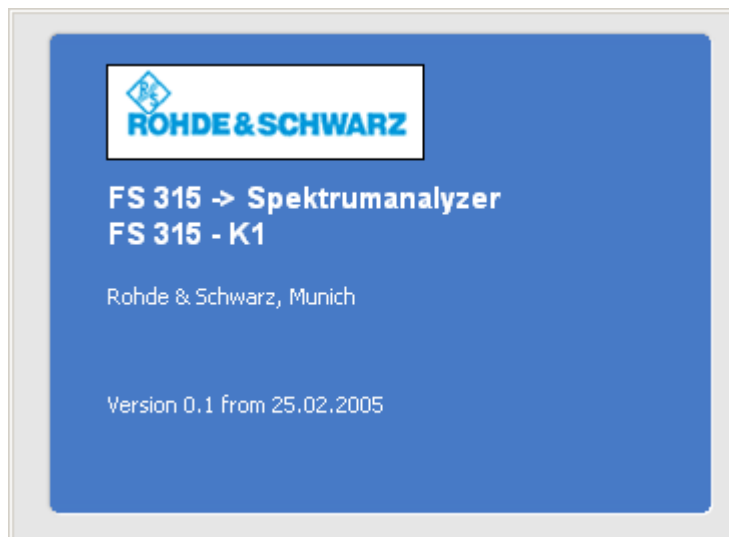

2. Click in the information field with the mouse to close.

You may also wait approximately 10 seconds for the information field to close automatically.

7.10.3 Displaying Module Data

Displaying module data

1. Select menu item: **Service** to obtain information about the individual modules.

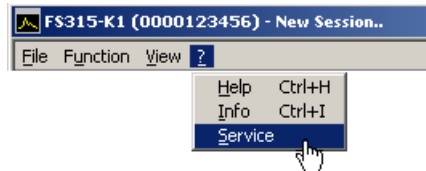

The modules of the R&S FS315 will be output and displayed.

The 'Service' window displays a table of installed modules. The table has four columns: 'Modul', 'Serial Number', 'part ID', and 'Revision'. The 'PowerSupply' row is highlighted in blue.

Modul	Serial Number	part ID	Revision
FS315	0000100015	0000.0000.00	0.0
PowerSupply	0000100677	1147.1400.50	0.989

Starting self-diagnostics

2. Click the line <FS315> to select the generator module.
3. Click <Self test> to start self-diagnostics.

All modules are checked one after the other and the result, "Passed" or "Error", is output.

The 'Self test' window displays a table of test results. The table has two columns: 'Part' and 'Result'. The 'Result' column shows 'Passed' for most items and 'Error' for others. An 'OK' button is visible at the bottom right.

Part	Result
✓ SRAM	Passed
✓ I2C	Passed
✓ FPGA	Passed
✓ WFMEM No. 1	Passed
✓ WFMEM No. 2	Passed
✓ WFMEM No. 3	Passed
X EEB DB	Error
X EEB AB	Error
X TEMPERATURE AB	Error
X TEMPERATURE DB	Error
X TEMPERATURE OSC	Error
✓ VOLTAGE AB	Passed
X VOLTAGE DB	Error

4. Click <OK> to close the Service window.

8 Instrument Interfaces

This chapter The chapter 8 contains a description of the R&S FS315's interfaces.

Further information The address of our Support Center and a list of Rohde & Schwarz service centers will be found at the front of this manual.

8.1 Keyboard Connector (KEYB)

Connector There is a 6-pin PS/2 connector KEYBOARD [22] on the R&S FS315's rear panel for an external keyboard.

Pin assignment	Pin	Signal
	1	KEYBOARDDATA
	2	MOUSEDATA
	3	GND
	4	5V, KEYBOARD
	5	KEYBOARDCLK
	6	MOUSECLK

8.2 Monitor Connector (MON)

Connector There is connector MONITOR [21] on the rear panel of the R&S FS315 for an external monitor.

Pin assignment	Pin	Signal
	1	R
	2	G
	3	B
	4	(NC)
	5	GND
	6	GND
	7	GND
	8	GND
	9	GND
	10	GND
	11	(NC)
	12	(NC)
	13	HSYNC
	14	VSYNC
	15	(NC)

8.3 Input for External Trigger (EXT TRIG)

Specification	The connector EXT TRIG/GATE IN [15] is for an external signal which is used to control measurements. The signal has TTL levels (low < 0.7 V, high > 1.4 V), and the typical impedance is 10 k Ω .
Instrument setting	The TRIG menu (\rightarrow 6-142) allows you to make the appropriate settings when an external signal is used to trigger measurements.

8.4 Reference Input and Output (REF IN and REF OUT)

External reference	If an external reference is used, the internal reference oscillator is synchronized to the 10 MHz reference signal at connector REF IN [24]. The input level must be 0.5 to 2 V.
Internal reference	The 10 MHz signal from the internal reference oscillator is available at the REF OUT connector [23] so that other devices can be synchronized to the R&S FS315. The output level is 7 dBm.
Instrument setting	You can switch over between the internal and external reference in the CONFIG menu (\rightarrow 6-187).

8.5 USB Interface (PC, DEV)

Connector The USB-Host [16] and USB-Device [17] connectors on the rear panel of the R&S FS315 are for a USB device.

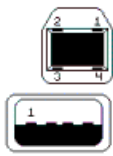
Pin assignment	Pin	Signal
	1	Vbus (Vcc)
	2	D-
	3	D+
	4	GND
	Shell	Shield

8.6 Headphone Output (AF OUT)

Connector	There is a connector AF Output [25] on the rear panel of the R&S FS315 for a headphone to listen to the demodulated AM/FM signal.
Specification	Connector: mini jack 3,5 mm Output impedance: 15 Ohm Voltage (100% Demod. Volume): 1 V (without load)
Instrument setting	The MEAS menu allows you to make the appropriate settings when an external headphone is used to listen to the demodulated signal (\rightarrow 6-148).

9 Error Messages

This chapter

Refer to chapter 8 for a detailed description of errors that may occur in the R&S FS315. You will also find notes on troubleshooting.

The R&S FS315 displays detected errors and warnings on the screen. The various types of messages are described in the following:

- System messages
- Warnings indicating impermissible operating states

Further information

Chapter 6 describes all the R&S FS315's menus and the associated functions in detail.

9.1 System Messages

System messages

System messages inform you of internally detected errors. The following informs are displayed, e. g.:

- Type of error (**x**)
- Four-digit error number (**y**)
- Request for closing the system messages (**z**)



The error number allows the service shop to determine the type of error. In the event of an system message, please write down the error number and proceed according to the following steps.

Device Error "Error number"

A system error was detected in the instrument.

1. Please write down the error number and the corresponding instrument settings.
2. Contact your nearest Rohde & Schwarz representative (0-24). The instrument may have to be checked in the service shop.

Overtemperature Error "Error number"

An impermissibly high temperature was detected in the instrument. The internal fans are switched to full power for approx. 30 seconds, and then the R&S FS315 is automatically switched off to prevent further overheating.

The overtemperature could be caused by too high an ambient temperature and/or reduced air circulation.

1. Let the instrument cool off for a while and remove any obstructions that could hinder air circulation.
2. If this doesn't eliminate the overtemperature, have the instrument checked by the service shop.

Note

Some errors can cause the instrument or parts of the instrument to be switched off immediately in order to avoid destruction of components. Whenever an system message occurs, an entry is made under SYSTEM MESSAGES (➔ 6-197).

9.2 Warnings Indicating Impermissible Operating States

Warnings

Red labels at the upper left corner of the measurement grid tell the user that the measurement results may be incorrect. This can be caused by excessively high signal levels at the input or by incorrect settings on the instrument. The warning remains on the screen until the problem has been eliminated.

There are several types of messages that can be displayed on the screen:

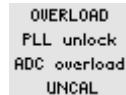

OVERLOAD A level above 13 dBm is detected at the R&S FS315 input and the current input attenuation setting is less than 20 dB. In this case, the instrument automatically increases the input attenuation by 20 dB to prevent the subsequent stages from being overdriven. The displayed signal level decreases by 20 dB as a result of the additional attenuation, without the display being corrected.

1. To obtain a correct level display, the reference level must be increased (↗ 6-84) until the message disappears.
2. If the message does not disappear, it is possible that the input attenuation is set to Manual. Raise the input attenuation above 20 dB (↗ 6-89), or switch to automatic setting of the input attenuation (↗ 6-90).

Note: This display will appear even if the signal is outside the currently selected span. In FULL SPAN mode (↗ 6-76), check whether a signal exceeds the permissible value and reduce the level if necessary.

PLL unlock The control loop, which is used to set the frequency of the internal reference oscillator with crystal accuracy, does not lock. This causes a frequency error, and the spectrum analyzer no longer operates according to specifications. The cause for this may be an internal instrument error or the absence of the 10 MHz reference signal at the external input REF IN. The absence of the reference signal, however, is not indicated unless the reference has been switched to “external”.

1. If the missing external reference signal is the cause of this error message, connect a 10 MHz signal to the REF IN [24] input or switch the reference to “internal” (↗ 6-187).
2. If the missing external reference signal is not the cause of this error message, an internal instrument error has occurred. In this case, switch the instrument off and on again. If the error message is still present, the instrument must be sent to the service shop to be checked.

ADC overload the level of the input signal is approx. 10 dB above the set reference level. In this case, the analog/digital converter is being overdriven, causing intermodulation products and distortions in the spectrum.

- This can be remedied by increasing the value for the reference level in the instrument (↗ 6-84).

UNCAL The message UNCAL appears if the resolution filter (RBW) and/or the video bandwidth (VBW) can no longer settle properly; this fault could result in level and frequency errors. The error is caused by the sweep time (↗ 6-126) being too short (this error can only occur if settings are made manually). The message will disappear if you switch the sweep time to AUTO mode.

Other parameters which influence this error are SPAN (↗ 6-75) and resolution bandwidth (RBW, ↗ 6-119).

10 Index

A

AC line
 Connection 3-39
 Voltage..... 3-39
 AC line fuse 2-36
 AC line switch 2-36
 Action keys 5-49, 7-228
 ADC overload (warnings) 9-273
 Adjust (window size)..... 7-266
 AM/FM demodulation 6-160
 Analyze (logfile)..... 7-254
 Arrow keys (description)..... 7-226
 ASCII file (measuring data) 7-255
 Attenuation..... *See* Input attenuation
 Averaging..... 6-135
 AVG (trace info)..... 6-137
 AVG detector 6-129

B

Back key 5-49
 Bandwidth
 Channel power 6-149
 Demodulation 6-161
 Occupied (channel power) 6-151
 Resolution..... 6-119
 Video..... 6-120
 Begin (measurement)..... 7-246

C

Call up
 Input field 7-231, 7-232
 Menu..... 7-230
 Center frequency
 Entry 6-73
 Step size 6-80, 6-104
 Change
 Input fields 7-228
 Menu..... 7-230
 Window color 7-267
 Channel power
 Bandwidth 6-149
 Measure..... 6-149
 Configuration (program) 7-200
 Connection (USB)..... 7-203, 7-207, 7-216
 Connectors 8-270
 Control
 With arrow keys 7-226
 With mouse..... 7-229
 With space key 7-228
 With tab key 7-228
 Control (program)..... 7-222
 Control elements 2-35
 Coupling
 Default 6-122
 Input attenuation..... 6-90

RBW, VBW and SPAN 6-121
 RBW/SPAN..... 6-123
 Reference level 6-90
 Sweep time 6-126
 Create (Program)..... 7-211
 Cursor keys
 Description 5-48
 Parameter entry 5-59

D

Date 6-185
 Default setting
 Coupling RBW/SPAN 6-123
 Default settings
 Coupling..... 6-91, 6-122
 Instrument 6-70
 Demodulation
 Filter bandwidth..... 6-161
 Mode 6-161
 Monitoring volume..... 6-161
 Detector 6-128
 Device Drivers
 Windows™ 2000 7-203
 Windows™ XP 7-207
 Device Error (system messages) 9-272
 Diagram area 5-51
 Diagram display 7-223
 Display
 Demodulation settings 6-175
 Diagram 7-223
 Frequency 6-72, 6-73, 6-75, 6-79
 Instrument settings 6-171
 Marker 6-95, 6-99
 Module data 7-269
 Program version..... 7-268
 Settings for the channel power measurement
 6-173
 Settings for transducer sets 6-176
 Spectrum analyzer settings 6-172
 Statistics..... 6-196
 Trace 6-131
 Tracking generator settings 6-174
 Window 7-222
 Display line..... 6-110
 Display mode, trace 6-135
 Displaying module data 7-269

E

ENTER..... 5-49
 Enter (action key)..... 7-228
 Entry..... *See* Parameter entry
 Error messages 9-272
 Esc (action key) 7-228
 ESC/CANCEL 5-49
 Exit (program) 7-217, 7-219
 Export (measuring data) 7-255

- External triggering input.....8-271
- F**
- Find maximum 6-95, 6-99
- Frequency
- Counter6-97
 - Measurement.....6-97
 - Range 6-75, 6-79
- Frequency (tracking generator)6-159
- Frequency axis
- Display mode6-76
 - Display modes6-78
 - Setting..... 6-73, 6-75, 6-79
- Frequency offset (tracking generator)6-154
- FS315 (USB connection).. 7-203, 7-207, 7-216
- Function
- Display7-225
 - Keys (description).....7-227
- Function key area, key assignment.....5-52
- Function keys
- Assignment.....5-61
 - Description..... 5-48, 5-52
- Function test3-40
- Functions (overview)7-234
- Fuse2-36
- H**
- Handle3-37
- Headphones8-271
- Help (start).....7-268
- Hz5-47
- I**
- Input..... See parameter input
- Input attenuation
- Automatic.....6-90
 - Coupling.....6-90
 - LOW DISTORTION6-90
 - LOW NOISE6-90
 - Manual6-89
 - NORMAL6-90
- Input field
- Call up.....7-231
 - Edit.....7-230
 - Exit.....7-228
- Input sensitivity6-92
- Inputs8-270
- Install (program)7-200
- Instrument
- Functions (overview)7-234
 - USB connection 7-203, 7-207, 7-216
- Instrument functions5-61
- Instrument interfaces6-188
- Instrument Interfaces.....8-270
- Instrument settings
- Displaying 5-68, 6-171
 - PRESET6-169
 - Save.....7-248
 - User-defined6-177
- K**
- Key assignment See Function key area
- Function keys..... 5-61
- Keyboard connector..... 8-270
- L**
- Level (tracking generator)..... 6-159
- Level axis
- Display range 6-86
 - Offset 6-85
 - Reference value6-84
- Level display range6-86
- Level offset.....6-85
- Tracking generator..... 6-158
- Limit lines (display) 7-249
- Logfile
- Analyze 7-254
 - Save7-252
- M**
- Marker
- Display7-220, 7-223, 7-234
 - Move 7-234
 - Peak excursion 6-112
 - Values 7-220, 7-223, 7-234
- Markers
- Center frequency 6-102
 - Display 5-51
 - Frequency measurements 6-97
 - Level differences..... 6-100
 - Maximum 6-95, 6-99
 - Noise power density 6-106
 - Signal bandwidth..... 6-108
 - Step size 6-104
 - Trace6-95
 - Values 5-51
- Math6-138
- MAX6-136
- Max. Hold6-135
- Maximum6-95
- Measurement
- AM/FM demodulation..... 6-160
 - Channel Power 6-148
 - Exit7-219
 - Frequency 6-97
 - Monitore 7-249
 - Noise power density 6-106
 - Occupied bandwidth 6-151
 - Power6-145
 - Signal bandwidth..... 6-108
 - Start.....7-246
 - TOI6-162
 - Tracking generator..... 6-152
 - Transducer function 6-164
- Measurement example
- Frequency 4-43
 - Frequency response 4-45
 - Level 4-43
 - Twoport 4-45

- Measurement sensitivity 6-92
- Measuring data (export) 7-255
- Measuring example
 - Frequency 7-219
 - Level 7-219
- Menu
 - AMPT 5-62, 6-83
 - BW/SWEEP 5-64, 6-118
 - Call up and change 7-230
 - Calling and changing 5-53
 - Display 7-224
 - FREQ/SPAN 5-61, 6-72
 - MEAS 5-66, 6-143
 - MKR 5-62, 6-93
 - Overview 5-61
 - TRACE 5-65, 6-131
 - TRIG 5-65, 6-140
- Menu area 5-52
- Menus (overview) 7-237
 - BW/Sweep 7-240
 - File (pull-down) 7-234
 - Frequency 7-236
 - Function (pull-down) 7-235
 - Help (pull-down) 7-245
 - Marker 7-238
 - Measure 7-243
 - Trace 7-241
 - Trigger 7-242
 - View (pull-down) 7-245
- Min. Hold 6-135
- Model designation 6-196
- Monitor
 - Display 7-222
 - Measuring values 7-249
- Monitor connector 8-270
- Mouse (control) 7-220, 7-229, 7-234
- N**
- Navigate
 - With arrow keys 7-226
 - With mouse 7-229
 - With space key 7-228
 - With tab key 7-228
- Noise power density 6-106
- Numeric keys (description) 7-226
- Numerical keys
 - Description 5-47
 - Parameter entry 5-57
- O**
- Offset
 - Level 6-85
 - Trigger 6-142
- Operating hours 6-196
- Operating mode
 - Freq Fixed (tracking generator) 6-159
 - Spectrum analyzer 6-71
 - System settings 6-167
 - Tracking (tracking generator) 6-154
- Operation
 - Manual 5-47
- Outputs 8-270
- OVERLOAD (warnings) 9-273
- Overtemperature Error (system messages) ... 9-272
- Overview
 - Functions 7-234
 - Menus 7-234
 - Shortcuts 7-234
- Overwrite mode 6-135
- P**
- Parameter entry
 - Direct 5-55
 - Numerical entry 5-57
 - Selection 5-56
- Parameter input
 - Direct 7-231
 - Select 7-232
 - With arrow keys 7-232
 - With numeric keys 7-232
- PC
 - System requirements 7-200
 - USB connection 7-203, 7-207, 7-216
- PC monitor *See monitor*
- PC software *See program*
- PEAK detector 6-129
- Peak excursion 6-112
- PLL unlock (warnings) 9-273
- Power
 - Measurement in the time domain (ZERO SPAN) 6-144
 - Measuring the channel power (SPAN < 0) . 6-148
 - Noise power density 6-106
- Power-on cycles 6-196
- Preset 6-169
- Print
 - Window (screenshot) 7-257
- Program
 - Control 7-222
 - Create 7-211
 - Exit 7-219
 - Install 7-200
 - Start 7-217
 - Uninstall 7-213
 - update 7-214
 - Version (display) 7-268
- Putting into operation 3-37
- Q**
- QUASI PEAK detector 6-129
- R**
- RBW *See Resolution bandwidth*
- Reference
 - Input and Output 8-271
 - Point on measurement diagram 6-115

- Point on trace 6-115
- Reference level
 - Coupling..... 6-90
 - Entry 6-84
- Reference point
 - on measurement diagram 6-115
 - on trace..... 6-115
- Reference position of trace (tracking generator) 6-158
- Reference source
 - External..... 6-187
 - Internal..... 6-187
- Reset 6-169
- Resolution bandwidth 6-119
- RF attenuation See Input attenuation
- RF input 6-83
- RMS detector..... 6-129
- Rotary knob
 - Description..... 5-48
 - Parameter entry 5-59
- S**
- SAMPLE detector 6-129
- Save
 - Instrument settings 7-248
 - Logfile 7-252
 - Measuring data (ASCII file) 7-255
 - Screenshot (window) 7-256
- Screen
 - Layout..... 5-50
 - Zooming..... 6-78
- Screen saver 6-190
- Screenshot
 - Print window 7-257
 - Save Window..... 7-256
- Self-diagnostics 7-269
- Selftests 6-194
- Service Manager Series 300
 - start..... 7-211
- Setting lever..... 3-37
- Setting up the Instrument 3-37
- Settings (instrument)
 - Save..... 7-248
- Shortcuts (overview)..... 7-234
- Signal
 - Marker functions 6-93
- Signal bandwidth 6-108
- Space key 7-228
- Span
 - changing the 6-76, 6-78
 - Entry 6-75
- Start
 - Help 7-268
 - Measurement..... 7-246
 - Program 7-217
- Start (Service Manager Series 300)..... 7-211
- Start frequency 6-79
- Step size center frequency 6-104
- Step size, center frequency..... 6-80
- Stock number..... 6-196
- Stop frequency..... 6-79
- Sweep See Frequency sweep
 - Continuous..... 6-125
 - n-times 6-125
 - Number of 6-125
 - Time 6-126
- SYS
 - Key 5-49
 - System functions..... 6-167
- System information 6-195
- System messages 9-272
 - Device Error 9-272
 - Overtemperature Error..... 9-272
- System requirements (PC) 7-200
- T**
- Tab key 7-228
- Third-order intercept point 6-162
- Time 6-185
- Time axis..... 6-77
- Time domain (ZERO SPAN)
 - Power measurement..... 6-144
 - Switchover 6-77
- TOI 6-162
- Trace See Trace
 - Averaging..... 6-135
 - Difference function 6-138
 - Math 6-138
 - Max. Hold 6-135
 - Min. Hold..... 6-135
 - Overwrite mode..... 6-135
 - Selection 6-132
- Traces
 - Blanking 6-137
 - Freezing 6-137
- Tracking generator
 - Entering frequency..... 6-159
 - Entering level 6-159
 - Freq Fixed..... 6-159
 - Frequency offset 6-154
 - Level offset..... 6-158
 - Reference position of trace..... 6-158
 - Selecting mode 6-154
 - Tracking 6-154
 - Transmission measurement 6-154
- Transducer factors
 - Creating 7-258
- Transducer function 6-164
- Transducer Sets
 - Using..... 6-165
- Transmission measurement 6-154
- Trigger
 - Free-running 6-141
 - Internal 6-141
 - Offset 6-142
 - Video 6-141

U	
UNCAL (warning)	9-274
Uninstall (program).....	7-213
Unit keys	5-47
Update (Program).....	7-214
USB connection.....	7-203, 7-207, 7-216
USB interface	8-271
USB stick	3-42
V	
VBW.....	See Video bandwidth
Video bandwidth	6-120
Volume (demodulation)	6-161
W	
Warnings	7-223, 9-273
Z	
ADC overload.....	9-273
OVERLOAD	9-273
PLL unlock	9-273
UNCAL	9-274
Window	
Adjust window size	7-266
Change window color	7-267
Display	7-222
Print screenshot.....	7-257
Save screenshot.....	7-256
Z	
Zoom.....	6-78
Zoom functions	7-245