

R&S® EX-IQ-Box (Model K04) Digital Signal Interface Module Specifications

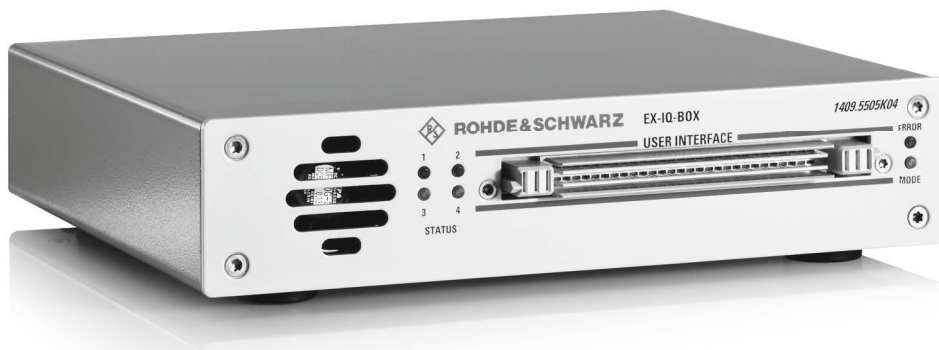

CONTENTS

Definitions	3
Introduction	4
Key features	5
General concept of operation	6
R&S® DigIConf digital interface configuration software.....	7
Test of DigRFSM modules	8
Test of CPRITM modules	10
Overview of the Rohde & Schwarz instruments that work with the R&S® EX-IQ-BOX and list of the required options.....	12
Signal interfaces	13
User-defined digital interface protocol	14
I/Q data	14
Clock	14
DigRFSM digital interface protocol (R&S® EXBOX-B81/-K13 options).....	15
CPRITM digital interface protocol (R&S® EXBOX-B85/-K10/-K11 options).....	18
Waveform memory (R&S® EXBOX-K90/-K91 options)	21
Recording memory (R&S® EXBOX-K94 option).....	22
Digital standards with R&S® WinIQSIM2TM (for R&S® EXBOX-K90/-K91 options).....	23
General data	24
Ordering information	25

Definitions

General

Product data applies under the following conditions:

- Three hours storage at ambient temperature followed by 30 minutes warm-up operation
- Specified environmental conditions met
- Recommended calibration interval adhered to
- All internal automatic adjustments performed, if applicable

Specifications with limits

Represent warranted product performance by means of a range of values for the specified parameter. These specifications are marked with limiting symbols such as $<$, \leq , $>$, \geq , \pm , or descriptions such as maximum, limit of, minimum. Compliance is ensured by testing or is derived from the design. Test limits are narrowed by guard bands to take into account measurement uncertainties, drift and aging, if applicable.

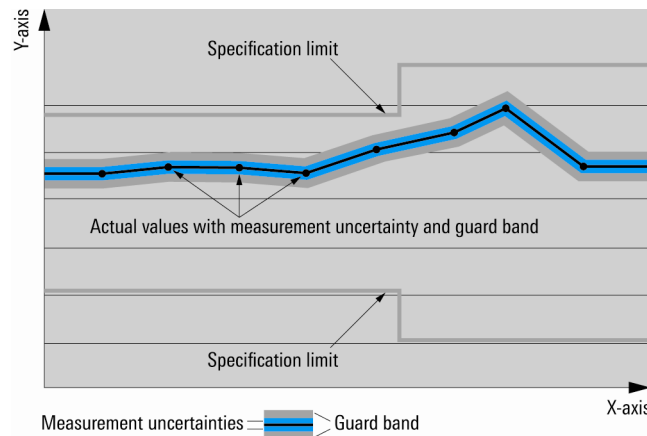

Specifications without limits

Represent warranted product performance for the specified parameter. These specifications are not specially marked and represent values with no or negligible deviations from the given value (e.g. dimensions or resolution of a setting parameter). Compliance is ensured by design.

Typical data (typ.)

Characterizes product performance by means of representative information for the given parameter. When marked with $<$, $>$ or as a range, it represents the performance met by approximately 80 % of the instruments at production time. Otherwise, it represents the mean value.

Nominal values (nom.)

Characterize product performance by means of a representative value for the given parameter (e.g. nominal impedance). In contrast to typical data, a statistical evaluation does not take place and the parameter is not tested during production.

Measured values (meas.)

Characterize expected product performance by means of measurement results gained from individual samples.

Uncertainties

Represent limits of measurement uncertainty for a given measurand. Uncertainty is defined with a coverage factor of 2 and has been calculated in line with the rules of the Guide to the Expression of Uncertainty in Measurement (GUM), taking into account environmental conditions, aging, wear and tear.

Device settings and GUI parameters are designated with the format "parameter: value".

Typical data as well as nominal and measured values are not warranted by Rohde & Schwarz.

Introduction

The R&S®EX-IQ-BOX is a digital signal interface module that provides flexible digital baseband inputs or outputs for Rohde & Schwarz signal generators, signal analyzers and communications testers. The main application field of this device is the conversion of digital I/Q signals of Rohde & Schwarz instruments into user-defined or standardized digital signal formats, and vice versa.

For applications with user-defined protocols, the R&S®EX-IQ-BOX enables either serial or parallel transmission of I/Q signals to a DUT, including variable clock modes, various data rates as well as different logical signal levels. The device under test is connected via adapter boards (= breakout boards) that are plugged directly into the R&S®EX-IQ-BOX.

In applications with standardized protocols, the R&S®EX-IQ-BOX provides not only the I/Q data, but also control information of the respective standard. Equipped with the corresponding options, the R&S®EX-IQ-BOX supports the standardized interface protocols CPRI™ (common public radio interface) as well as DigRFSM. Both define an interface for the transmission of I/Q and control data between baseband and RF module of a base station or mobile terminals respectively.

The parameters can conveniently be set via the R&S®DiglConf digital interface configuration software.

When equipped with the R&S®EX-IQ-BOX, a Rohde & Schwarz vector signal generator delivers realistic digital baseband signals for testing digital transceivers or other components. It can thus cover all common state-of-the-art standards such as LTE, WiMAX™ and 3GPP including HSPA, as well as user-defined signals and effects such as fading, AWGN or I/Q impairments. The R&S®EX-IQ-BOX plus a Rohde & Schwarz signal analyzer enable the reliable analysis of digital baseband components.

As an accessory for a Rohde & Schwarz communications tester, the R&S®EX-IQ-BOX acts as a versatile digital baseband interface for signal generation and signal evaluation.

WiMAX Forum is a registered trademark of the WiMAX Forum. WiMAX, the WiMAX Forum logo, WiMAX Forum Certified, and the WiMAX Forum Certified logo are trademarks of the WiMAX Forum.

CDMA2000® is a registered trademark of the Telecommunications Industry Association (TIA - USA).

CPRI™ is a trademark of Nokia Siemens Networks.

DigRFSM is a trademark of MIPI.

Key features

- Digital I/Q interface for signal generators, analyzers and communications testers from Rohde & Schwarz
 - Standard-compliant digital baseband signals
 - Signal generation for all important state-of-the-art standards such as EUTRA/LTE, 3GPP FDD, HSPA, WiMAX™, GSM/EDGE (together with the R&S®SMW200A, R&S®SMU200A, R&S®SMJ100A, R&S®SMBV100A or R&S®AMU200A)
 - Versatile signal processing functionalities including AWGN generation and I/Q impairments (together with the R&S®SMW200A, R&S®SMU200A, R&S®SMJ100A, R&S®SMBV100A or R&S®AMU200A)
 - Fading simulation (together with the R&S®SMW200A, R&S®SMU200A, R&S®AMU200A)
 - Simple and flexible conversion of digital baseband signals into analog IF or RF signals (together with the R&S®SMW200A, R&S®SMU200A, R&S®SMBV100A or R&S®AMU200A)
 - Vector signal analysis of digital baseband signals of all important modern standards such as EUTRA/LTE, 3GPP FDD, HSPA, WiMAX™, GSM/EDGE (together with the R&S®FSW, R&S®FSQ, R&S®FSG, R&S®FSV, R&S®FSVR or R&S®FMU)
 - State-of-the-art test solution for wideband radiocommunications tests at the digital baseband interface of components (together with the R&S®CMW500)
- Digital interface protocol “user-defined”
 - Flexible data formats
 - Maximum data rate of 100 MHz/200 MHz (SN>102000) , variable resampling in conjunction with the Rohde & Schwarz instrument
 - Variable word size from 4 bit to 18 bit for I and Q
 - Parallel and serial formats
 - SDR and DDR data rates
 - Non-interleaved and I/Q and Q/I interleaved formats
 - Selectable bit order and word alignment
 - Two's complement and binary offset representation
 - Negate I and Q data
 - Positive and negative logic
 - Flexible clock generation
 - Maximum clock rate of up to 100 MHz/200 MHz (SN>102000) for parallel formats and up to 400 MHz for serial formats
 - Internal and external clock reference
 - Selectable clock phase (90° steps) and skew (±5 ns)
 - Variable signal interface
 - LVTTTL, CMOS (1.2 V, 1.5 V, 1.8 V, 2.5 V and 3.3 V) and LVDS logic standards
 - Two breakout boards included (single-ended, differential connectors) for connection of the device under test
- Digital interface protocol DigRFSM (with R&S®EXBOX-B81 and R&S®EXBOX-K13)
 - Test of DigRFSM 3G RFICs by means of R&S®EXBOX-K13 option
 - Flexible hardware configuration and test case definition via freely configurable scripts
 - Hardware scheduler with timing resolution of 6.4 ns
 - PN16 and sine test signal generator for the physical layer DigRFSM signal
 - DigRFSM specific breakout board for interfacing with the DUT (R&S®EXBOX-B81 option)
 - Support of DigRFSM 3G signals
 - Clock frequencies of 19.2/26/38.4/52 MHz
 - GPIO and GPIO group signals as well as SPI, I2C and RFFE buses for communications with external devices
 - Four user I/O BNC connectors with freely assignable function (trigger, marker, etc.)
- Digital interface protocol CPRI™ (with R&S®EXBOX-B85 and R&S®EXBOX-K10/-K11 options)
 - Test of CPRI™ radio equipment (RE) by means of R&S®EXBOX-K10 option
 - Test of CPRI™ radio equipment control (REC) by means of R&S®EXBOX-K11 option
 - Predefined interface settings for 3GPP FDD (incl. HSDPA, HSUPA, HSPA+), LTE, WiMAX™, GSM/EDGE, CDMA2000® as well as user-defined configuration
 - Supported line bit rates:
 - 1228.8 Mbit/s (= 2 ×), 2457.6 Mbit/s (= 4 ×) and 3072.0 Mbit/s (= 5 ×) with R&S®EXBOX-B85 (1409.7208.02)
 - 1228.8 Mbit/s (= 2 ×), 2457.6 Mbit/s (= 4 ×) and 3072.0 Mbit/s (= 5 ×), 4815.2 Mbit/s (= 8 ×), 6144.0 Mbit/s (= 10 ×) and 9830.4 Mbit/s (= 16 ×) with R&S®EXBOX-B85 (1409.7208.04)
 - Flexible/packed antenna carrier (AxC) allocation with antenna carrier (AxC) grouping
 - Vendor-specific data
 - Versatile trigger and synchronization capabilities
 - Control and management (C&M): fast C&M (realtime via Ethernet) and slow C&M (HDLC, realtime via RS-232)
 - CPRI™ specific breakout board for interfacing with the DUT (R&S®EXBOX-B85 option)
 - Support of standard small form factor pluggable (SFP) modules for optical link
 - Additional SMA connectors for simultaneous monitoring of the CPRI™ output or for supply of the RX input signal
- Waveform playback and recording (for CPRI™ and DigRFSM)
 - Direct playback from the R&S®EX-IQ-BOX waveform memory (64 Msample) by means of the R&S®EXBOX-K90 option
 - Multi-waveform playback for simultaneous output of up to four waveforms by means of the R&S®EXBOX-K91 option
 - Support of R&S®WinIQSIM2™ waveform creation software
 - Recording memory (512 Mbyte) for capturing of data that is received via the CPRI™ or DigRFSM link
- Easy interface configuration via enclosed R&S®DigIConf software
 - Transient recorder for visual control of the generated digital signals (I/Q diagram, vector diagram, CCDF, spectrum)
 - Remote control of all parameters via LAN

General concept of operation

The R&S[®]EX-IQ-BOX digital signal interface module can be used in multiple ways. It either acts as an input interface to the DUT or as an output interface for data from the DUT. Signal generation and/or signal analysis are performed by the connected Rohde & Schwarz instrument that is used in conjunction with the R&S[®]EX-IQ-BOX.

Breakout boards are used to adapt the digital signal of the R&S[®]EX-IQ-BOX to different physical digital interfaces (single-ended, differential, etc.). The use of user-designed breakout boards is also possible. The R&S[®]EX-IQ-BOX digital interface module is configured via the enclosed R&S[®]DigiConf software or directly via the controlling instrument (instrument-dependent).

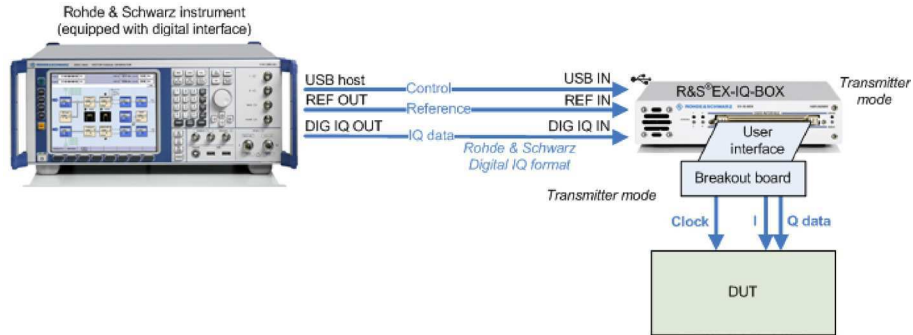

Configuration example: R&S[®]EX-IQ-BOX as a signal output interface, directly controlled by a Rohde & Schwarz instrument (R&S[®]SMU200A, R&S[®]SMJ100A or R&S[®]AMU200A).

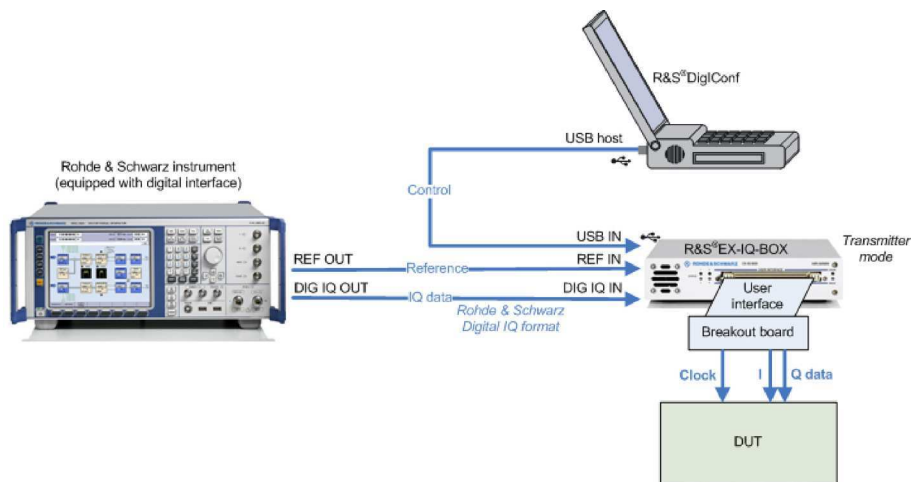

Configuration example: R&S[®]EX-IQ-BOX as a signal output interface, controlled via the R&S[®]DigiConf configuration software.

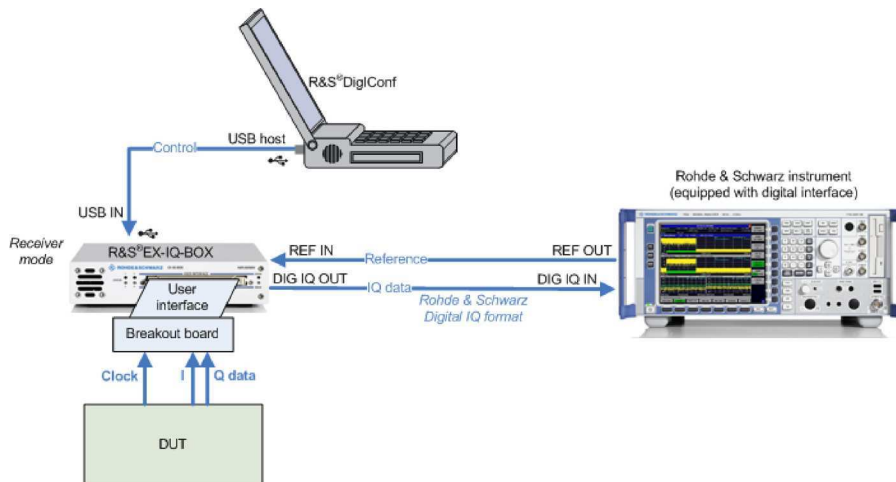

Configuration example: R&S[®]EX-IQ-BOX as a signal input interface, controlled via the R&S[®]DigiConf configuration software.

R&S® DigIConf digital interface configuration software

The R&S® DigIConf controls the protocol, data, level and clock settings of the R&S® EX-IQ-BOX. R&S® DigIConf allows all interface settings to be selected independently of the connected Rohde & Schwarz instrument. Up to four R&S® EX-IQ-BOX instruments can be controlled directly from the R&S® DigIConf software. The program is to be installed on a PC running a Windows 2000/XP (Service Pack 2 required) or Windows 7 (32 bit/64 bit) operating system.

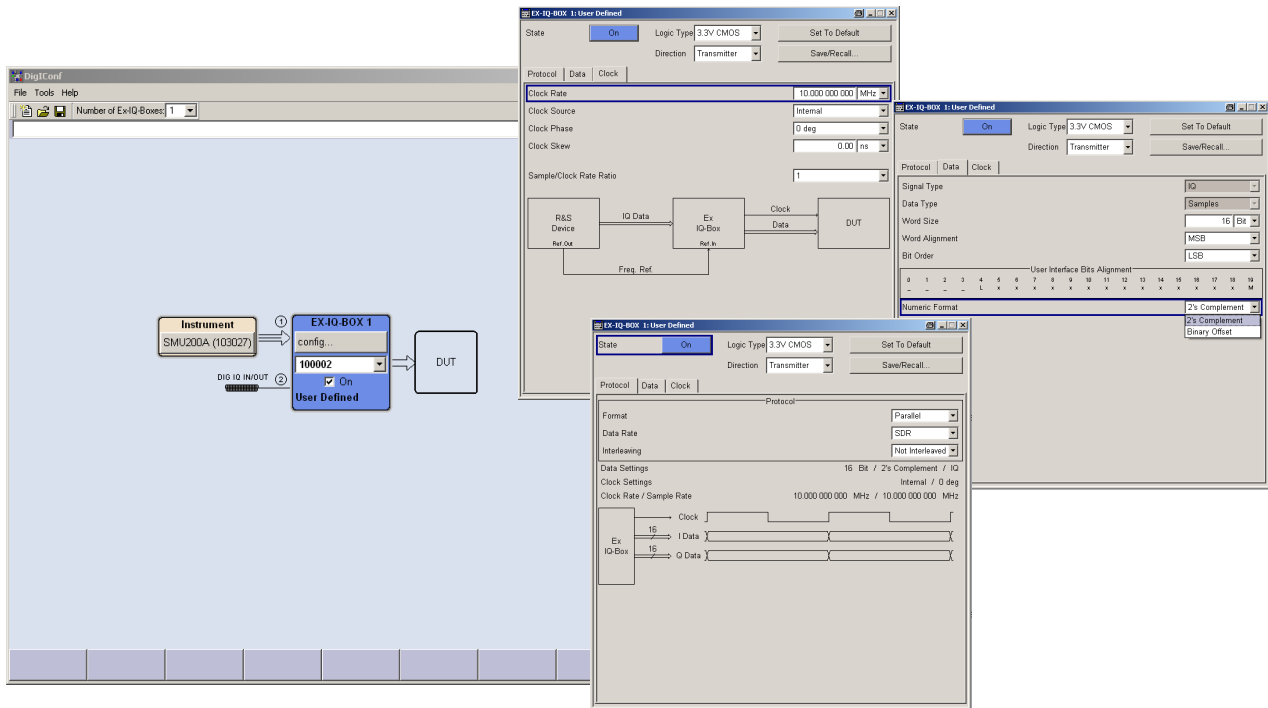

R&S® DigIConf digital interface configuration software; flexible control of up to four R&S® EX-IQ-BOX instruments.

Test of DigRFSM modules

Together with the R&S[®]EXBOX-B81 and R&S[®]EXBOX-K13 options, the R&S[®]EX-IQ-BOX generates and receives signals in line with the DigRFSM digital interface protocol standard. The test solution allows physical layer verification of RF-ICs that communicate via DigRFSM 3G (by means of R&S[®]EXBOX-K13). The device under test (DUT) is connected via the DigRFSM specific breakout board (R&S[®]EXBOX-B81 option). Without the need for a fully functioning BB-IC, stand-alone RF-IC testing is made easy and the design cycle can be shortened.

Flexible test setup control is provided by the R&S[®]DigIConf configuration software: all relevant R&S[®]Ex-IQ-BOX settings are accessible in a straight-forward manner. The chip at test is controlled via DigRFSM scripts that are first loaded to R&S[®]DigIConf and compiled therein. Second, the compiled script is transferred to the R&S[®]EX-IQ-BOX for execution. DigRFSM parameters as well as additional user data are also exchanged with the R&S[®]EX-IQ-BOX via R&S[®]DigIConf. I/Q waveform files (e.g. from R&S[®]WinIQSIM2[™] or MATLAB[®]) can be loaded to the optional arbitrary memory (ARB) of the R&S[®]EX-IQ-BOX, and recorded I/Q data can be read out from the optional recording memory of the R&S[®]EX-IQ-BOX. Alternatively, the R&S[®]EX-IQ-BOX can communicate with attached Rohde & Schwarz instruments via the Rohde & Schwarz digital I/Q interface.

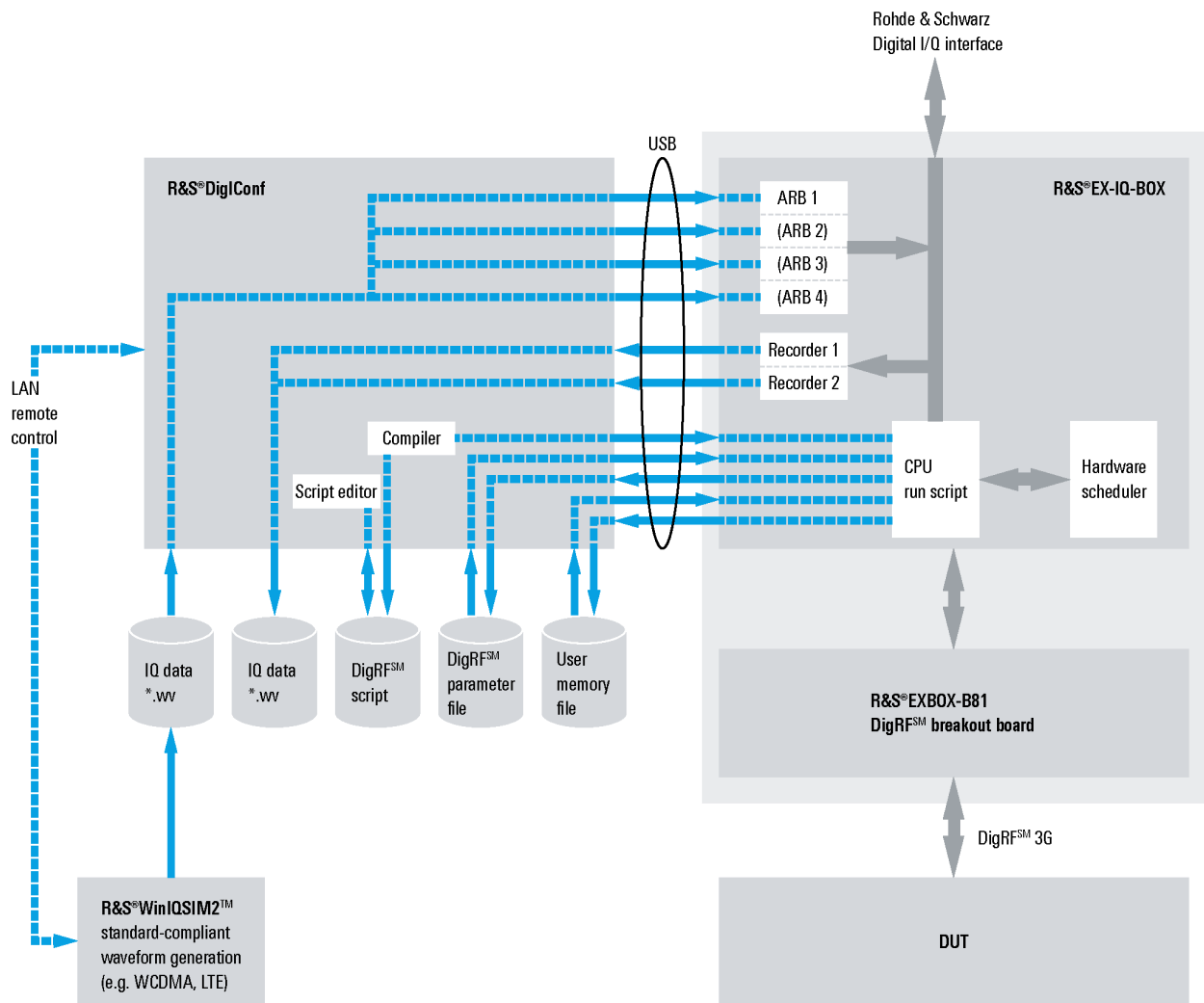

R&S[®]EX-IQ-BOX, connectivity for DigRFSM.

Further information on DigRFSM can be found at www.mipi.org.

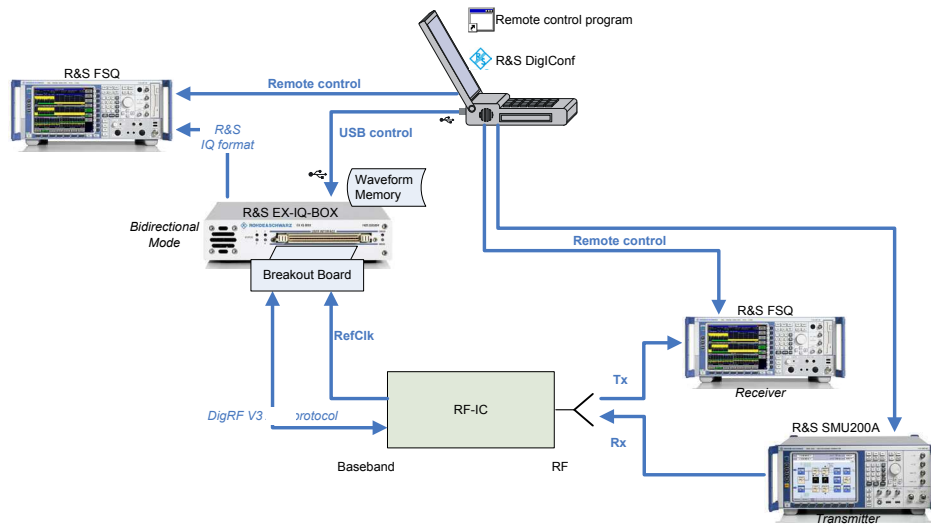

Test setup example for full-duplex DigRFSM RF-IC test using R&S[®] EX-IQ-BOX (with R&S[®] EXBOX-B81 and R&S[®] EXBOX-K13 options), R&S[®] SMU200A and R&S[®] F&S&Q.

Test of CPRI™ modules

When equipped with the R&S®EXBOX-B85 and R&S®EXBOX-K10/-K11 options, the R&S®EX-IQ-BOX generates and receives signals in line with the common public radio interface (CPRI™) protocol standard by converting the data accordingly.

This enables the user to perform tests directly by using the CPRI™ interface between the base station radio equipment control (REC) and the base station radio equipment (RE). Straightforward connection to the device under test (DUT) is achieved via the CPRI™ specific breakout board (R&S®EXBOX-B85 option). Both entities, the RE (by means of R&S®EXBOX-K10) as well as the REC (by means of R&S®EXBOX-K11) can be tested independently from each other. This helps to speed up time to market and to save valuable resources in research, development, verification and production.

Easy CPRI™ interface configuration is ensured by the R&S®DiglConf configuration software. All state-of-the-art standards such as 3GPP FDD (incl. HSDPA, HSUPA, HSPA+), LTE, WiMAX™, CDMA2000® and GSM/EDGE are supported as predefined interface settings. Additionally, the CPRI™ interface can be configured manually. The test solution provides individual uplink or downlink operation as well as full-duplex operation. Control and management information can be inserted in realtime.

The R&S®EX-IQ-BOX can also be equipped with an internal waveform memory option (R&S®EXBOX-K90/-K91) that allows playback of precalculated waveforms (e.g. generated by R&S®WinIQSIM2™ or MATLAB®). The R&S®EXBOX-K91 option makes it possible to play back up to four waveforms at the same time. As a result, up to four different signals can be simultaneously transmitted via the same CPRI™ link (e.g. for multistandard, diversity or MIMO applications).

A complementary recording memory option (R&S®EXBOX-K94) captures the I/Q data that is received by the R&S®EX-IQ-BOX via the CPRI™ link from the DUT. The received I/Q samples are stored in an internal memory of 512 Mbyte and are available for offline signal analysis and customer-specific post-processing by use of third-party tools.

Furthermore – when combined with the Rohde & Schwarz signal generators and spectrum analyzers – the R&S®EX-IQ-BOX is able to utilize the enhanced functions of the signal generators (e.g. digital communications standards, fading, AWGN, impairments) and the vast signal analysis features of the spectrum analyzers (e.g. ACP and EVM measurements for digital standards) even at the digital signal interface. The elaborate CPRI™ test solution from Rohde & Schwarz is a straightforward approach to test CPRI™ modules (RE and/or REC) and additionally offers the flexibility to tailor the test solution to customer needs.

Further information on CPRI™ can be found at www.cpri.info.

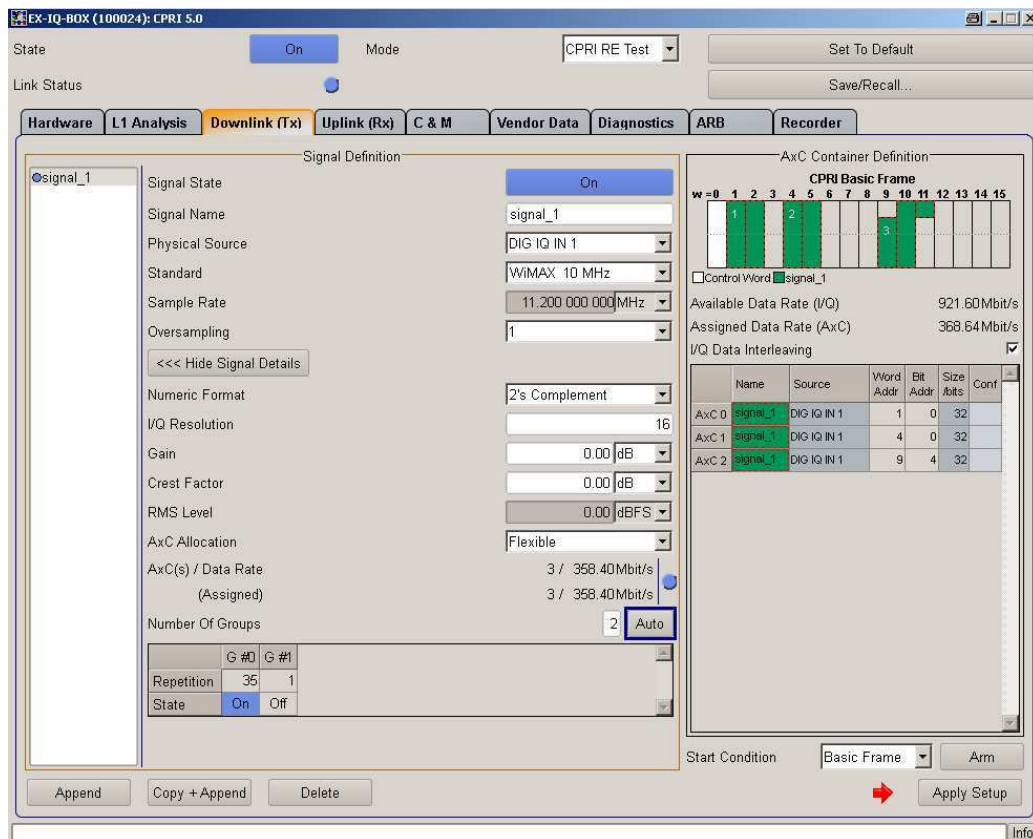

Configuration of the CPRI™ interface via the R&S®DiglConf digital interface configuration software.

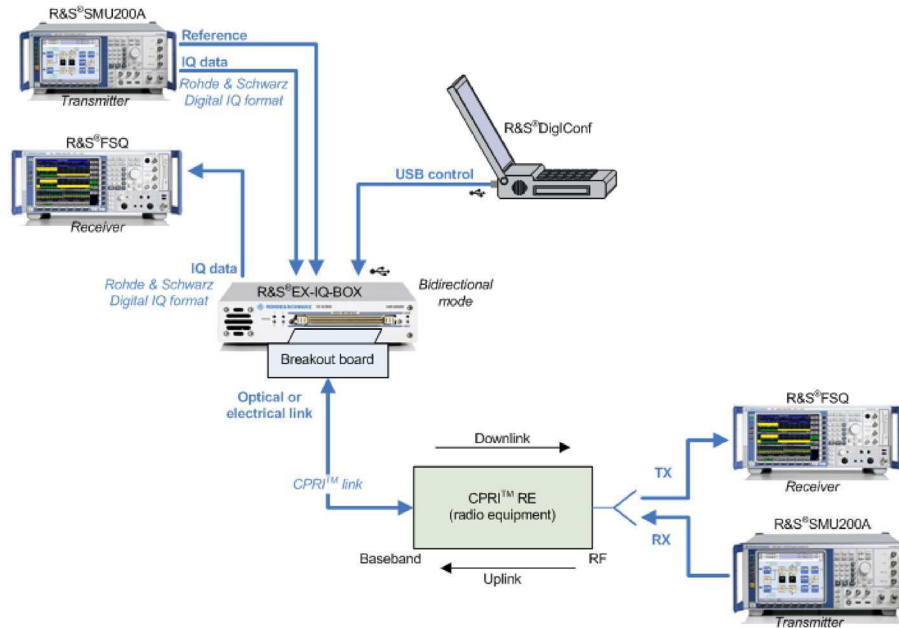

Test setup example for full-duplex CPRI™ radio equipment (RE) test using R&S®EX-IQ-BOX (with R&S®EXBOX-B85 and R&S®EXBOX-K10 options), R&S®SMU200A and R&S®FSQ.

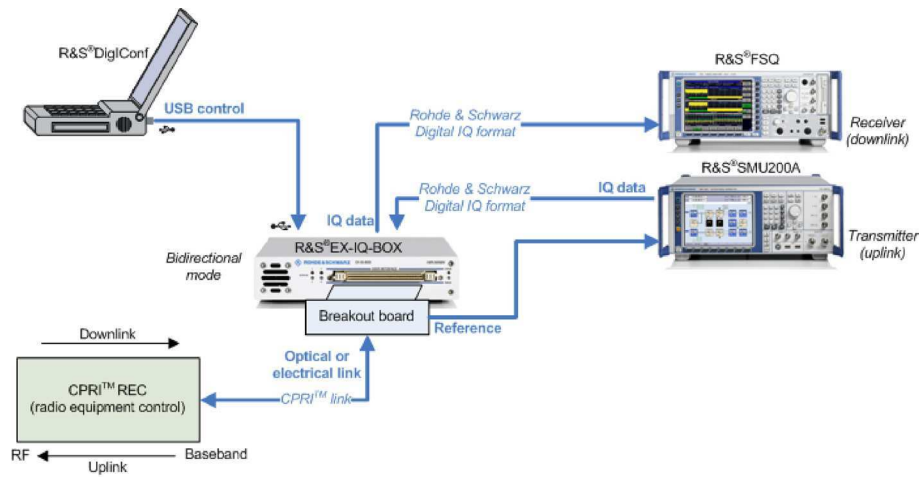

Test setup example for full-duplex CPRI™ radio equipment control (REC) test using R&S®EX-IQ-BOX (with R&S®EXBOX-B85 and R&S®EXBOX-K11 options), R&S®SMU200A and R&S®FSQ.

Overview of the Rohde & Schwarz instruments that work with the R&S®EX-IQ-BOX and list of the required options

Rohde & Schwarz instrument	Digital I/Q input option	Digital I/Q output option
Signal generators		
R&S®AMU200A baseband signal generator and fading simulator	R&S®AMU-B17 ¹ analog/digital baseband inputs	R&S®AMU-B18 ² digital baseband output
R&S®SMW200A vector signal generator	R&S®SMW-B10 ¹ baseband generator	R&S®SMW-K18 ² digital baseband output
R&S®SMU200A vector signal generator	R&S®SMU-B17 analog/digital baseband inputs	R&S®SMU-B18 digital baseband output
R&S®SMJ100A vector signal generator	–	R&S®SMJ-B18 digital baseband output
R&S®SMBV100A vector signal generator	R&S®SMBV-K18 digital baseband connectivity	R&S®SMBV-K18 digital baseband connectivity
Signal analysis		
R&S®FSW signal and spectrum analyzer	R&S®FSW-B17 digital baseband interface	R&S®FSW-B17 digital baseband interface
R&S®FSQ signal analyzer	R&S®FSQ-B17 digital baseband interface	R&S®FSQ-B17 digital baseband interface
R&S®FSG signal analyzer	R&S®FSQ-B17 digital baseband interface	R&S®FSQ-B17 digital baseband interface
R&S®FMU36 baseband signal analyzer	R&S®FSQ-B17 digital baseband interface	R&S®FSQ-B17 digital baseband interface
R&S®FSV signal and spectrum analyzer	R&S®FSV-B17 digital baseband interface	R&S®FSV-B17 digital baseband interface
R&S®FSVR signal and spectrum analyzer	R&S®FSV-B17 digital baseband interface	R&S®FSV-B17 digital baseband interface
Communications testers		
R&S®CMW500 wideband radio communication tester	R&S®CMW-B510A digital I/Q	R&S®CMW-B510A digital I/Q
Data recorders		
R&S®IQR I/Q data recorder	standard	standard

¹ With two path-instruments that are equipped with a second digital baseband input option, a second R&S®EX-IQ-BOX can be connected.

² With two path-instruments that are equipped with a second digital baseband output option, a second R&S®EX-IQ-BOX can be connected.

Signal interfaces

User signal interface	direction	input, output
	signals	bidirectional, dual 18-bit data buses for I and Q signals; two marker, trigger and auxiliary signals each
	connector	168-pin Tyco Z-Dok connects to breakout boards (included) with the following connector types:
		2 × 50-pin dual 0.1 in header (single ended)
		2 × 100-pin dual Samtec (LVDS)
	absolute maximum input level	
LVTTL, 3.3 V CMOS	−0.5 V, +3.8 V	
1.2 V CMOS, 1.5 V CMOS, 1.8 V CMOS, 2.5 V CMOS	−0.5 V, $V_{cc} + 0.4 V$	
LVDS	−0.5 V, +2.9 V	
Interface I/Q in, I/Q out	interface for connecting the Rohde & Schwarz instrument	Rohde & Schwarz digital I/Q Interface, I/Q data and control signals, data and interface clock ³
	logic level	LVDS
	connector	26-pin MDR
	clock rate	66 MHz to 100 MHz/200 MHz (SN>102000)
	max. data rate	clock rate

³ Rohde & Schwarz Digital I/Q Interface is a Rohde & Schwarz company standard for the transmission of digital I/Q data. It is supported by a wide range of instruments (signal generators, signal analyzers and communications testers).

User-defined digital interface protocol

Enables the generation and reception of signals with user-defined protocols.

I/Q data

Format		parallel, serial
Serial format	strobe position	0 to word size – 1
	strobe polarity	positive, negative
Sample rate		1 kHz to 100 MHz/200 MHz (SN>102000)
Resampling		automatically performed by the Rohde & Schwarz instrument if required
I/Q impairments, I/Q swap		by the Rohde & Schwarz instrument
Signal type		I/Q, IF (complex)
IF frequency		(clock rate)/4
Numeric format		two's complement, binary offset
Word size		4 bit to 18 bit (depending on the Rohde & Schwarz instrument)
Data protocol		SDR, DDR
Ratio of sample rate to clock rate		1, 4/5, 2/5, 1/5, 1/10, 1/20
Interleaving		none, I/Q, Q/I
Word alignment		MSB, LSB
Bit order		MSB, LSB
Negate data		I, Q, I + Q
Logic type		positive, negative
Logic level	single-ended	LVTTTL, 1.2 V CMOS, 1.5 V CMOS, 1.8 V CMOS, 2.5 V CMOS, 3.3 V CMOS
	differential	LVDS

Clock

Clock rate	reference source, internal		
	LVTTTL/CMOS logic level	1 kHz to 100 MHz/200 MHz (SN>102000)	
	LVDS logic level	1 kHz to 400 MHz	
	reference source, external		
	LVTTTL/CMOS logic level	25 kHz to 100 MHz/200 MHz (SN>102000)	
	LVDS logic level	25 kHz to 400 MHz	
Reference	source	internal (from Rohde & Schwarz instrument) external from user interface	
	internal input		
	impedance	50 Ω (nom.)	
	frequency	5 MHz, 10 MHz, 13 MHz (automatically selected)	
	level	–3 dBm to 10 dBm	
	external user interface input frequency		
	LVTTTL/CMOS logic level	25 kHz to 100 MHz/200 MHz (SN>102000)	
	LVDS logic level	25 kHz to 400 MHz	
	Clock polarity	user interface	positive, negative
	Clock phase (relative to data)		0°, 90°, 180°, 270°
Clock skew (relative to data)	range	–5 ns to +5 ns	
	resolution	50 ps	

DigRFSM digital interface protocol (R&S[®]EXBOX-B81/-K13 options)

Enables the R&S[®]EX-IQ-BOX to generate and receive signals in line with the DigRFSM digital interface protocol standard. The R&S[®]EXBOX-B81 (DigRFSM breakout board) option is a mandatory prerequisite for R&S[®]EXBOX-K13 (DigRFSM 3G RF-IC test option). Only available for R&S[®]EX-IQ-BOX with serial number > 102000.

Applications		simulation of BB-IC to test a RF-IC
Protocol version	with R&S [®] EXBOX-K13 option	DigRF SM 3G 3.09.04
		all frame types and payload sizes
		all line rates
		sleep mode
Operation		hardware configuration and script operation via enclosed R&S [®] DigIConf software; DigRF test cases can be covered via user-programmed scripts
	script language	Pawn
	script commands	common Pawn script commands; R&S [®] EX-IQ-BOX interface configuration (e.g. line rate, sleep mode); sending and receiving of control and data frames; sending and receiving of data frames via streams; operation of GPIO, GPIO Group, SPI, I ² C and RFFE; operation of user memory (e.g. for boot or calibration data); operation of script parameter; operation of hardware scheduler (for timing critical sequences); wait, halt, resume
	script parameter	
	number	32
	size	32 bit (each)
	script memory	16 Mbyte
	user memory	
	number	2
	size	1 Mbyte (each)
	hardware scheduler	
	number	2
	stages	512 (each)
	timing resolution	6.4 ns
	commands	GPIO out, send control frame, wait, send single frame with stream
	I/Q payload input for streams	payload for one logical data channel can be input in realtime via the Rohde & Schwarz digital I/Q interface; PN16 via internal test generator; sine test generator; waveform memory (R&S [®] EXBOX-K90/-K91 options)
	I/Q payload output for streams	payload from one received logical data channel can be output in realtime via the Rohde & Schwarz digital I/Q interface; recording memory (R&S [®] EXBOX-K94 option); payload tester
	marker	
	number	4
	trigger source	frame header (1 byte) and payload (3 byte)
	testing, diagnosis	payload tester; status and error information

DigRF SM breakout board (R&S [®] EXBOX-B81 option)		
Clock	RF-IC test: the breakout board generates an additional synchronous reference frequency for auxiliary equipment from the fed SysClk (RefClk)	
	clock 1	SysClk (RefClk)
	direction	input or output
	frequency	19.2/26/38.4/52 MHz
	level	1.1 V to 1.9 V
	output spectral purity	
	integrated phase noise from 10 kHz to 10 MHz	-66 dBc (nom.)
	noise floor density from 50 kHz to 10 MHz	-140 dBc(1 Hz) (nom.)
	clock 2	reference signal output for auxiliary instruments, synchronous to SysClk (RefClk)
	direction	output
	frequency	5/10 MHz
	level	1.1 V to 3.4 V
	connector	SMA
	DigRF control	DigRF control signals
DigRF SM 3G		
signals		SysClkEn, InterfaceEn
level		1.1 V to 1.9 V
connector		ERNI SMC-1.27 mm, 50 pins (DigRF control)
DigRF SM 3G	the breakout board supports two TX data and RX data links	
	TX	
	number	2 (differential)
	line rates	low speed (SysClk/4)
		high speed (312 Mbps)
	polarity	normal, inverted
	differential impedance	100 Ω (nom.)
	return loss (≤ 156 MHz)	-13 dB (nom.)
	TX 1	
	common mode offset	0.1 V to 1.5 V
	differential level	0.05 V to 0.4 V (Vpp)
	slew rate	normal, slow
	shutdown mode	yes
	TX 2	
	common mode offset	1.2 V (nom.)
	differential level	0.4 V (Vpp) (nom.)
	RX	
	number	2 (differential)
	line rate	low speed (SysClk/4)
		medium speed(SysClk)
		high speed (312 Mbps)
	polarity	normal, inverted
	differential impedance	100 Ω (nom.)
	common mode voltage range	0.1 V to 3.2 V
	differential level range	0.1 V to 1 V (Vpp)
	connectors	SMA

GPIO/GPIO group/SPI/I2C/RFFE	GPIO	a 24 signals wide bidirectional bus as stimulus of proprietary interfaces
	direction	input or output, individually configurable for each signal
	level	1.2 V to 3 V (nom.)
	connector	ERNI SMC-1.27 mm, 50 pins (GPIO/SPI/I2C/RFFE)
	GPIO group	a 40 signals wide (5 groups with 8 signals each) bidirectional bus as stimulus of proprietary interfaces
	direction	input or output, individually configurable for each group
	level	1.2 V to 3 V (nom.), individually configurable for each group
	connector	ERNI SMC-1.27 mm, 50 pins (GPIO group)
	SPI	SPI bus for communications with external devices
	signals	SCLK, 2 MISO, 2 SS, 1 MOSI
	level	1.2 V to 3 V (nom.)
	connector	ERNI SMC-1.27 mm, 50 pins (GPIO/SPI/I2C/RFFE)
	I ² C	I2C master for communication with external I2C devices
	signals	SCL, SDA
	levels	1.2 V to 3 V (nom.)
	connector	ERNI SMC-1.27 mm, 50 pins (GPIO/SPI/I2C/RFFE)
RFFE	RFFE master and slave busses for communications with RF front-end components (e.g. filters, converters, sensors)	
signals	2 × SCLK, 2 × SDATA	
levels	1.2 V to 1.8 V (nom.)	
connector	ERNI SMC-1.27 mm, 50 pins (GPIO/SPI/I2C/RFFE)	
User I/O	4 bidirectional signals (2 groups with 2 signals each) with freely assignable operation (e.g. trigger, marker, user signals)	
	direction	input or output, individually configurable for each group
	level	3.3 V
	connectors	BNC

CPRI™ digital interface protocol (R&S®EXBOX-B85/-K10/-K11 options)

Enables the R&S®EX-IQ-BOX to generate and receive signals in line with the CPRI™ digital interface protocol standard. The R&S®EXBOX-B85 (CPRI™ breakout board) option is a mandatory prerequisite for R&S®EXBOX-K10 (CPRI™ RE test option) and/or R&S®EXBOX-K11 (CPRI™ REC test option). Only available for R&S®EX-IQ-BOX.

Applications	simulation of radio equipment control (REC) to test a radio equipment (RE), simulation of radio equipment (RE) to test a radio equipment control (REC)		
CPRI™ digital interface protocol	with R&S®EXBOX-B85 breakout board variant 1409.7208.02	in line with CPRI™ standard, version 4.0	
	with R&S®EXBOX-B85 breakout board variant 1409.7208.04	in line with CPRI™ standard, version 5.0	
Simulation mode	with R&S®EXBOX-K10 option	REC (to test RE)	
	with R&S®EXBOX-K11 option	RE (to test REC)	
Mobile standards	3G	3GPP FDD, 3GPP FDD HSDPA, 3GPP FDD HSUPA, 3GPP FDD HSPA+, CDMA2000®	
	beyond 3G	LTE, WiMAX™, GSM/EDGE	
CPRI™ configuration			
Link directions		uplink	
		downlink	
Signal definition	signal = I/Q stream with settable sample rate to be mapped to AxC(s)		
	number of configurable signals	1 to 4 (depending on configuration)	
	I/Q payload input	realtime via the R&S®Digital I/Q Interface; PN16 via internal test generator; user-definable 36-bit pattern via internal test generator; waveform memory (R&S®EXBOX-K90/-K91 options)	
	I/Q payload output	one selectable I/Q signal inside the received CPRI™ frame can be output in realtime via the R&S®Digital I/Q Interface. recording memory (R&S®EXBOX-K94 option)	
	I/Q format	two's complement, 10-bit floating point format with common exponent (9E2)	
	signal standard	3GPP FDD	
		CDMA2000®	
		LTE: 1.4/2.5/5/10/15/20 MHz	
		WiMAX™: 3.5/5/7/8.75/10/20 MHz	
	sample rate	user-defined	
		GSM/EDGE	
	sample rate	automatic in line with selected standard user-defined: 1 kHz to 100 MHz	
	oversampling		
	uplink	1, 2, 4	
	downlink	1, 2, 4	
	I/Q resolution		
	uplink	4 bit to 18 bit	
	downlink	4 bit to 18 bit	
	AxC allocation		
	packed	word and bit address set automatically	
flexible	user-definable word and bit address		
assigned AxCs	full AxCs automatically assigned depending on signal data rate		
assigned data rate adaptation for non-3.84 MHz multiple signal data rates	via user-definable AxC over time assignment configuration		

Control and management (C&M)	fast C&M	Ethernet (realtime)
	slow C&M	via integrated terminal window in R&S®DigiConf bit rates 240/480/960/1920/2400//3840/4800/ 7680 kbit/s (depending on line bit rate); HDLC-coded data in realtime via RS-232
	vendor-specific data	input and display of vendor data
	layer 1 in band protocol	
	with R&S®EXBOX-K10 option	
	TX	generate RE Reset, SDI
	RX	evaluate LOS, LOF, RAI, SDI
	with R&S®EXBOX-K11 option	
	RX	evaluate LOS, LOF, RAI, SDI, RE Reset
	Layer 1 analysis	layer 1 in band protocol
	link status	local and remote alarms (LOS,LOF,RAI, SDI, RESET)
	link events	generate reset, SDI
Visualization	framing	graphical display of CPRI™ basic frame configuration
Testing		loopback mode
		low level BER measurement at physical layer
Start condition	TX	Software
		Ext trigger 1, 2,3
		TX basic frame
		TX hyper frame
		TX NodeB frame
	RX	Software
		Ext trigger 1, 2,3
		RX basic frame
		RX hyper frame
		RX NodeB frame
	recorder	sync pattern
		Software
		Ext trigger 1, 2,3
		RX basic frame
		RX hyper frame
RX NodeB frame		
sync pattern		
TX basic frame		
TX hyper frame		
TX NodeB frame		
Interleaving	TX interleaving	off/on (according to standard)
	RX Deinterleaving	off/on (according to standard)

CPRI™ breakout board (R&S® EXBOX-B85 option)		
Connection of DUT		via CPRI™ specific breakout board
Interfaces (general)	small form factor pluggable (SFP) cage in line with multisource agreement (MSA), September 14, 2000	basic SFP control (LVCMOS) enhanced SFP control (I ² C) module diagnostics
	SFP cages	
	with R&S® EXBOX-B85 breakout board variant 1409.7208.02	2
	with R&S® EXBOX-B85 breakout board variant 1409.7208.04	1
	SFP module	to be supplied by user
	SMA	TX level adjustment (02 board variant) RX equalizer (02 board variant) simultaneous CPRI™ output for signal monitoring (02 board variant)
	line bit rate	
	with R&S® EXBOX-B85 breakout board variant 1409.7208.02	2 × (1228.8 Mbit/s)
		4 × (2457.6 Mbit/s)
		5 × (3072.0 Mbit/s)
	with R&S® EXBOX-B85 breakout board variant 1409.7208.04	1 × (614.4 Mbit/s)
		2 × (1228.8 Mbit/s)
		4 × (2457.6 Mbit/s)
		5 × (3072.0 Mbit/s)
8 × (4915.2 Mbit/s)		
10 × (6144.0 Mbit/s)		
	16 × (9830.4 Mbit/s)	
TX interfaces	total jitter	in line with CPRI™ req. 0.35 SI _{pp}
	SMA connectors	
	number	1 (differential)
	logic type	CML (in line with XAUI)
	differential level (with R&S® EXBOX-B85 breakout board variant) 1409.7208.02	0.1 V to 1.6 V (V _{pp})
	differential level (with R&S® EXBOX-B85 breakout board variant) 1409.7208.04	0.8 V (V _{pp})
	coupling	DC
	common mode offset	1.65 V (nom.)
differential impedance	100 Ω (nom.)	
RX interfaces	total jitter tolerance	in line with CPRI™ req. 0.35 SI _{pp}
	SMA connectors	
	number	1 (differential)
	logic type	CML (in line with XAUI)
	differential level	> 100 mV (V _{pp})
	coupling	AC
	differential impedance	100 Ω (nom.)
	return loss (at line bit rate)	-12 dB (nom.)
Fast C&M	type	Ethernet
	connectors	RJ-45
	number	1
	rate	10/100 Mbit/s
Slow C&M	type	HDLC
	connectors	DB9
	number	1
	level	LVCMOS 3.3 V
General purpose input and output (GPIO)	application	marker output clock output
	connectors	BNC
	number	3
	direction	output
	level	LVCMOS3.3

Waveform memory (R&S® EXBOX-K90/-K91 options)

Enables the use of I/Q waveforms (together with the R&S® EXBOX-K10, R&S® EXBOX-K11 or R&S® EXBOX-K13 option). Waveforms can be generated by means of the R&S® WinIQSIM2™ waveform creation software, for example.

R&S® EX-IQ-BOX and R&S® EXBOX-B85 as well as R&S® EXBOX-K10 or -K11 options or R&S® EXBOX-B81 as well as R&S® EXBOX-K13 option are required.

Waveform memory	size (shared by all active waveforms)	64 Msample
	resolution	16 bit I and 16 bit Q (output resolution depending on application settings)
	waveform length	1 sample to 64 Msamples in one-sample steps
	number of waveforms in parallel	
	with R&S® EXBOX-K90 option	1
	with R&S® EXBOX-K90 and -K91 options	4
Sample rate	setting	
	with R&S® EXBOX-K10/-K11	depending on the sample rate set in the option where the waveform is referenced
	with R&S® EXBOX-K13	controlled by RF-IC
	maximum rate	
	for one active recording or waveform playback	100 Msample/s
	sum data rate for multiple active recordings and/or waveform playbacks	160 Msample/s

Recording memory (R&S®EXBOX-K94 option)

Allows recording of the I/Q data that is received by the R&S®EX-IQ-BOX via the CPRI™ or DigRFSM link from the DUT. With the DigRFSM link, data can also be recorded in raw mode.

R&S®EX-IQ-BOX and R&S®EXBOX-B85 as well as R&S®EXBOX-K10 or -K11 options or R&S®EXBOX-B81 as well as R&S®EXBOX-K13 option are required.

Recording memory	size (shared by all active recordings)	512 Mbyte
	recording mode	
	with R&S®EXBOX-K10/-K11	I/Q samples
	with R&S®EXBOX-K13	I/Q samples, raw data
	number of recordings in parallel	2
	maximum data rate	
	for one active recording or waveform playback	100 Msample/s
sum data rate for multiple active recordings and/or waveform playbacks	160 Msample/s	
Recording mode I/Q samples	data length	1 sample to 128 Msample in one-sample steps
	resolution	16 bit I and 16 bit Q (effective resolution depending on application settings)
	data rate settings	
	with R&S®EXBOX-K10/-K11	depending on the sample rate set in the option where the data is referenced
	with R&S®EXBOX-K13	controlled by RF-IC
Recording mode raw	data length	1 word to 128 Mword in one-word steps
	word size	32 bit
	data rate settings	
	with R&S®EXBOX-K13	controlled by DigRF link settings

Digital standards with R&S® WinIQSIM2™ (for R&S® EXBOX-K90/-K91 options)

R&S® WinIQSIM2™ requires an external PC.

Standard	Option
GSM/EDGE	R&S® EXBOXK240
EDGE Evolution	R&S® EXBOXK241
3GPP FDD	R&S® EXBOXK242
3GPP FDD enhanced BS/MS tests including HSDPA	R&S® EXBOXK243
3GPP FDD enhanced BS/MS tests including HSUPA	R&S® EXBOXK245
CDMA2000®	R&S® EXBOXK246
1xEV-DO	R&S® EXBOXK247
IEEE 802.16	R&S® EXBOXK249
TD-SCDMA (3GPP TDD LCR)	R&S® EXBOXK250
TD-SCDMA (3GPP TDD LCR) enhanced BS/MS tests including HSDPA	R&S® EXBOXK251
IEEE 802.11n	R&S® EXBOXK254
EUTRA/LTE	R&S® EXBOXK255
HSPA+	R&S® EXBOXK259
EUTRA/LTE Release 9 and enhanced features	R&S® EXBOXK284
EUTRA/LTE Release 10	R&S® EXBOXK285
IEEE 802.11ac	R&S® EXBOXK286

The options are described in the R&S® WinIQSIM2™ data sheet (PD 5213.7460.22).

General data

Power supply (included)	input voltage range, AC, nominal	100 V to 240 V (AC), 50 Hz to 60 Hz
EMC		in line with EMC directive of EU (2004/108/EC), applied standard: EN 61326-1, EN 61326-2-1, EN 55011 (immunity for industrial environment, class A emissions) ⁴
Environmental conditions	operating temperature range	+5 °C to +40 °C in line with EN 60068-2-1, EN 60068-2-2
	storage temperature range	-20 °C to +60 °C
	climatic resistance	+40 °C/90 % rel. humidity in line with EN 60068-2-30
Mechanical resistance	vibration, sinusoidal	5 Hz to 150 Hz, max. 2 g at 55 Hz, const. 0.5 g at 55 Hz to 150 Hz, in line with EN 60068-2-6
	vibration, random	10 Hz to 300 Hz, acceleration 1.2 g (RMS), in line with EN 60068-2-64
	shock	in line with MIL-STD-810E, method no. 516.4, procedure I, 40 g shock spectrum
Electrical safety		In line with IEC 61010-1, EN 61010-1, UL 61010-1, CAN/CSA-C22.2 No. 61010-1-04
Approvals		VDE-GS, cCSA _{US}
Dimensions (W × H × D)	R&S [®] EX-IQ-BOX	198 mm × 47 mm × 190 mm (7.80 in × 1.85 in × 7.48 in)
	R&S [®] EXBOX-B81 breakout board	205 mm × 37 mm × 195 mm (8.07 in × 1.46 in × 7.68 in)
	R&S [®] EXBOX-B85 breakout board	190 mm × 37 mm × 135 mm (7.48 in × 1.46 in × 5.32 in)
Weight	R&S [®] EX-IQ-BOX	1 kg (2.2 lb)
	R&S [®] EXBOX-B81 breakout board	1 kg (2.2 lb)
	R&S [®] EXBOX-B85 breakout board	1 kg (2.2 lb)

⁴ The instrument complies with the emission requirements stipulated by EN 55011 class A. This means that the instrument is suitable for use in industrial environments. In line with EN61000-6-4, operation in residential, commercial and business areas or in small-size companies is not covered. Thus, the instrument may not be operated in residential, commercial and business areas or in small-size companies, unless additional measures are taken to ensure that EN 61000-6-3 is complied with.

Ordering information

Designation	Type	Order No.
Digital Signal Interface Module	R&S®EX-IQ-BOX	1409.5505K04
including power supply, 1 USB and 1 LVDS cable, 2 breakout boards, quick start guide, CD-ROM (with operating and service manual and R&S®DiglConf software)		
Options		
CPRI™ Breakout Board	R&S®EXBOX-B85	1409.7208.04
CPRI™ RE Test	R&S®EXBOX-K10	1417.1170.02
CPRI™ REC Test	R&S®EXBOX-K11	1417.1186.02
DigRF SM Breakout Board	R&S®EXBOX-B81	1409.7008.02
DigRF SM 3G RF-IC Test	R&S®EXBOX-K13	1417.1192.02
Waveform Memory (64 Msample)	R&S®EXBOX-K90	1417.1005.02
Multiwaveform Playback	R&S®EXBOX-K91	1417.1011.02
Recording Memory (512 Mbyte)	R&S®EXBOX-K94	1417.1028.02
Digital modulation systems using R&S®WinIQSIM2™ ⁵		
GSM/EDGE	R&S®EXBOXK240	1417.1034.02
EDGE Evolution	R&S®EXBOXK241	1417.1040.02
3GPP FDD	R&S®EXBOXK242	1417.1057.02
3GPP FDD Enhanced BS/MS Tests including HSDPA	R&S®EXBOXK243	1417.1063.02
3GPP FDD Enhanced BS/MS Tests including HSUPA	R&S®EXBOXK245	1417.1070.02
CDMA2000®	R&S®EXBOXK246	1417.1086.02
1xEV-DO	R&S®EXBOXK247	1417.1092.02
IEEE 802.16	R&S®EXBOXK249	1417.1111.02
TD-SCDMA (3GPP TDD LCR)	R&S®EXBOXK250	1417.1128.02
TD-SCDMA (3GPP TDD LCR) Enhanced BS/MS Tests including HSDPA	R&S®EXBOXK251	1417.1134.02
IEEE 802.11n	R&S®EXBOXK254	1417.1105.02
EUTRA/LTE	R&S®EXBOXK255	1417.1140.02
HSPA+	R&S®EXBOXK259	1417.1157.02
EUTRA/LTE Release 9 and enhanced features	R&S®EXBOXK284	1417.1240.02
EUTRA/LTE Release 10	R&S®EXBOXK285	1417.1257.02
IEEE 802.11ac	R&S®EXBOXK286	1417.1263.02
Accessories		
User Signal Interface Adapter (Tyco 128-pin Z-Dok adapter)	R&S®EXBOX-Z1	1409.7437.02
Cadence Paladium Breakout Board	R&S®EXBOX-Z3	1417.3566.02
LVDS Cable for connecting digital baseband interfaces	R&S®SMU-Z6	1415.0201.02

Service options		
Extended Warranty, one year	R&S®WE1	Please contact your local Rohde & Schwarz sales office.
Extended Warranty, two years	R&S®WE2	
Extended Warranty, three years	R&S®WE3	
Extended Warranty, four years	R&S®WE4	
Extended Warranty with Calibration Coverage, one year	R&S®CW1	
Extended Warranty with Calibration Coverage, two years	R&S®CW2	
Extended Warranty with Calibration Coverage, three years	R&S®CW3	
Extended Warranty with Calibration Coverage, four years	R&S®CW4	

Extended warranty with a term of one to four years (WE1 to WE4)

Repairs carried out during the contract term are free of charge⁶. Necessary calibration and adjustments carried out during repairs are also covered. Simply contact the forwarding agent we name; your product will be picked up free of charge and returned to you in top condition a couple of days later.

Extended warranty with calibration (CW1 to CW4)

Enhance your extended warranty by adding calibration coverage at a package price. This package ensures that your Rohde & Schwarz product is regularly calibrated, inspected and maintained during the term of the contract. It includes all repairs⁶ and calibration at the recommended intervals as well as any calibration carried out during repairs or option upgrades.

For product brochure, see PD 5213.9511.12 and www.rohde-schwarz.com

⁵ R&S®WinIQSIM2™ requires an external PC.

⁶ Excluding defects caused by incorrect operation or handling and force majeure. Wear-and-tear parts are not included.

Service that adds value

- | Worldwide
- | Local and personalized
- | Customized and flexible
- | Uncompromising quality
- | Long-term dependability

About Rohde & Schwarz

Rohde & Schwarz is an independent group of companies specializing in electronics. It is a leading supplier of solutions in the fields of test and measurement, broadcasting, radiomonitoring and radiolocation, as well as secure communications. Established more than 80 years ago, Rohde & Schwarz has a global presence and a dedicated service network in over 70 countries. Company headquarters are in Munich, Germany.

Quality management and environmental management

Rohde & Schwarz is certified in line with the ISO 9001 and ISO 14001 management systems.

Certified Quality Management

ISO 9001

Certified Environmental Management

ISO 14001**Rohde & Schwarz GmbH & Co. KG**www.rohde-schwarz.com**Regional contact**

- | Europe, Africa, Middle East | +49 89 4129 12345
customersupport@rohde-schwarz.com
- | North America | 1 888 TEST RSA (1 888 837 87 72)
customer.support@rsa.rohde-schwarz.com
- | Latin America | +1 410 910 79 88
customersupport.la@rohde-schwarz.com
- | Asia/Pacific | +65 65 13 04 88
customersupport.asia@rohde-schwarz.com
- | China | +86 800 810 8228/+86 400 650 5896
customersupport.china@rohde-schwarz.com

R&S® is a registered trademark of Rohde & Schwarz GmbH & Co. KG

Trade names are trademarks of the owners

PD 5214.2840.22 | Version 09.00 | January 2014 (as)

R&S®EX-IQ-Box (Model K04) Digital Signal Interface Module

Data without tolerance limits is not binding | Subject to change

© 2009 - 2014 Rohde & Schwarz GmbH & Co. KG | 81671 München, Germany



5214284022