

# R&S<sup>®</sup> SMW-K46

## CDMA2000<sup>®</sup>

### User Manual



1175675502  
Version 15

**ROHDE & SCHWARZ**  
Make ideas real



This document describes the following software options:

- R&S®SMW-K46 CDMA2000® (1413.3884.xx)

This manual describes firmware version FW 4.80.041.xx and later of the R&S®SMW200A.

© 2020 Rohde & Schwarz GmbH & Co. KG

Mühlhofstr. 15, 81671 München, Germany

Phone: +49 89 41 29 - 0

Email: [info@rohde-schwarz.com](mailto:info@rohde-schwarz.com)

Internet: [www.rohde-schwarz.com](http://www.rohde-schwarz.com)

Subject to change – Data without tolerance limits is not binding.

R&S® is a registered trademark of Rohde & Schwarz GmbH & Co. KG.

CDMA2000® is a registered trademark of the Telecommunications Industry Association (TIA -USA).

Trade names are trademarks of the owners.

1175.6755.02 | Version 15 | R&S®SMW-K46

The following abbreviations are used throughout this manual: R&S®SMW200A is abbreviated as R&S SMW, R&S®WinIQSIM2™ is abbreviated as R&S WinIQSIM2; the license types 02/03/07/11/13/16/12 are abbreviated as xx.

# Contents

<b>1</b>	<b>Welcome to the CDMA2000 Digital Standard</b>	<b>7</b>
<b>1.1</b>	<b>Accessing the CDMA2000 Dialog</b>	<b>7</b>
<b>1.2</b>	<b>Documentation Overview</b>	<b>8</b>
1.2.1	Getting Started Manual	8
1.2.2	User Manuals and Help	8
1.2.3	Tutorials	8
1.2.4	Service Manual	8
1.2.5	Instrument Security Procedures	9
1.2.6	Printed Safety Instructions	9
1.2.7	Data Sheets and Brochures	9
1.2.8	Release Notes and Open Source Acknowledgment (OSA)	9
1.2.9	Application Notes, Application Cards, White Papers, etc	9
<b>1.3</b>	<b>Scope</b>	<b>10</b>
<b>1.4</b>	<b>Notes on Screenshots</b>	<b>10</b>
<b>2</b>	<b>About this Digital Standard</b>	<b>11</b>
<b>2.1</b>	<b>Modulation System CDMA2000</b>	<b>13</b>
2.1.1	Modulation System CDMA2000 in the Downlink (Forward)	13
2.1.2	Modulation System CDMA2000 in the Uplink (Reverse)	13
2.1.3	Data Source - Uplink and Downlink	14
2.1.4	Channel Coding - Uplink and Downlink	14
2.1.5	Long-Code Scrambling Generator - Downlink	15
2.1.6	Power Control Puncturing - Downlink	15
2.1.7	Variable-Length Walsh Spreading - Downlink	16
2.1.8	PN Short-Code Scrambling - Downlink	16
2.1.9	Spreading - Uplink	16
2.1.9.1	Variable Length Walsh Spreading	16
2.1.9.2	64-Ary Orthogonal Modulator	16
2.1.10	Scrambling - Uplink	17
2.1.10.1	Scrambling for Radio Configuration 1 and 2	17
2.1.10.2	Scrambling for Radio Configuration 3, 4 and 5	18
2.1.11	Baseband Filtering - Uplink and Downlink	19

2.1.12	I/Q Modulator - Uplink and Downlink.....	19
2.1.13	Constellation of I/Q Signals - Downlink.....	20
2.1.13.1	BPSK Channels.....	20
2.1.13.2	QPSK Channels.....	21
2.1.14	Power Control - Downlink and Uplink.....	22
<b>3</b>	<b>CDMA2000 Configuration and Settings.....</b>	<b>23</b>
<b>3.1</b>	<b>General Settings for CDMA2000 Signals.....</b>	<b>23</b>
<b>3.2</b>	<b>Trigger Settings.....</b>	<b>26</b>
<b>3.3</b>	<b>Marker Settings.....</b>	<b>31</b>
<b>3.4</b>	<b>Clock Settings.....</b>	<b>32</b>
<b>3.5</b>	<b>Local and Global Connector Settings.....</b>	<b>34</b>
<b>3.6</b>	<b>CDMA2000 Basestations and Mobile Stations Settings.....</b>	<b>34</b>
3.6.1	Configure Base Station or Mobile Station.....	34
3.6.2	Predefined Settings - Downlink.....	38
3.6.3	Additional Mobile Station - Uplink.....	41
3.6.4	Base Station Configuration.....	43
3.6.4.1	Common Settings.....	43
3.6.4.2	Channel Table - BS.....	45
3.6.4.3	Code Domain and Channel Graphs.....	51
3.6.5	More Parameters - BS Channel Table.....	56
3.6.5.1	General Settings.....	57
3.6.5.2	Power Control.....	57
3.6.5.3	Channel Coding.....	60
3.6.5.4	Additional Sync Channel Parameters.....	63
3.6.6	More Parameters for F-PDCH - BS.....	65
3.6.6.1	General Settings for Packet Channel.....	66
3.6.6.2	Subpacket Table Settings.....	67
3.6.6.3	Subpacket Graph.....	69
3.6.7	Mobile Station Configuration (MS).....	70
3.6.7.1	Common Settings - MS.....	70
3.6.7.2	Power Control - MS.....	72
3.6.7.3	Channel Table - MS.....	74
<b>3.7</b>	<b>Filter / Clipping / ARB Settings.....</b>	<b>78</b>

3.7.1	Filter Settings.....	78
3.7.2	Clipping Settings.....	80
3.7.3	ARB Settings.....	81
3.7.4	I/Q Setting.....	81
<b>4</b>	<b>Remote-Control Commands.....</b>	<b>83</b>
<b>4.1</b>	<b>Primary Commands.....</b>	<b>84</b>
<b>4.2</b>	<b>Filter/Clipping Settings.....</b>	<b>91</b>
4.2.1	Filter Settings.....	91
4.2.2	Clipping Settings.....	94
<b>4.3</b>	<b>Trigger Settings.....</b>	<b>95</b>
<b>4.4</b>	<b>Marker Settings.....</b>	<b>99</b>
<b>4.5</b>	<b>Clock Settings.....</b>	<b>101</b>
<b>4.6</b>	<b>Predefined Settings.....</b>	<b>102</b>
<b>4.7</b>	<b>Base Stations Settings.....</b>	<b>107</b>
<b>4.8</b>	<b>Mobile Station Settings.....</b>	<b>137</b>
	<b>List of commands.....</b>	<b>150</b>
	<b>Index.....</b>	<b>153</b>



# 1 Welcome to the CDMA2000 Digital Standard

The R&S SMW-K46 is a firmware application that adds functionality to generate signals in accordance with the CDMA2000 standard 3GPP2 C.S0002-C, version 1.0, May 2002 (release C). CDMA2000® is a registered trademark of the Telecommunications Industry Association (TIA –USA).

The R&S SMW simulates CDMA2000 at the physical channel level. The following list gives an overview of the R&S SMW-K46 features:

- Configuration of up to four base stations or four mobile stations
- All special channels and up to 78 channels on the downlink (depending on the radio configuration)
- Packet channel according to 1xEV-DV on the downlink
- Operating modes "Traffic", "Access", "Enhanced Access" and "Common Control" on the uplink
- "Misuse For Output Power Control" parameter for varying the original normal transmit power over time
- Simulation of up to 64 additional mobile stations
- Clipping for reducing the crest factor
- All channel coding modes included in IS-2000 (Frame Quality Indicator, Convolutional Encoder, Turbo Encoder, Symbol Puncture, Interleaver, etc.)

This user manual contains a description of the functionality that the application provides, including remote control operation.

All functions not discussed in this manual are the same as in the base unit and are described in the R&S SMW user manual. The latest version is available at:

[www.rohde-schwarz.com/manual/SMW200A](http://www.rohde-schwarz.com/manual/SMW200A)

## Installation

You can find detailed installation instructions in the delivery of the option or in the R&S SMW service manual.

## 1.1 Accessing the CDMA2000 Dialog

### To open the dialog with CDMA2000 settings

- ▶ In the block diagram of the R&S SMW, select "Baseband > CDMA2000".

A dialog box opens that displays the provided general settings.

The signal generation is not started immediately. To start signal generation with the default settings, select "State > On".

## 1.2 Documentation Overview

This section provides an overview of the R&S SMW user documentation. Unless specified otherwise, you find the documents on the R&S SMW product page at:

[www.rohde-schwarz.com/manual/smw200a](http://www.rohde-schwarz.com/manual/smw200a)

### 1.2.1 Getting Started Manual

Introduces the R&S SMW and describes how to set up and start working with the product. Includes basic operations, typical measurement examples, and general information, e.g. safety instructions, etc. A printed version is delivered with the instrument.

### 1.2.2 User Manuals and Help

Separate manuals for the base unit and the software options are provided for download:

- **Base unit manual**  
Contains the description of all instrument modes and functions. It also provides an introduction to remote control, a complete description of the remote control commands with programming examples, and information on maintenance, instrument interfaces and error messages. Includes the contents of the getting started manual.
- **Software option manual**  
Contains the description of the specific functions of an option. Basic information on operating the R&S SMW is not included.

The contents of the user manuals are available as help in the R&S SMW. The help offers quick, context-sensitive access to the complete information for the base unit and the software options.

All user manuals are also available for download or for immediate display on the Internet.

### 1.2.3 Tutorials

The R&S SMW provides interactive examples and demonstrations on operating the instrument in form of tutorials. A set of tutorials is available directly on the instrument.

### 1.2.4 Service Manual

Describes the performance test for checking compliance with rated specifications, firmware update, troubleshooting, adjustments, installing options and maintenance.

The service manual is available for registered users on the global Rohde & Schwarz information system (GLORIS):

<https://gloris.rohde-schwarz.com>

### 1.2.5 Instrument Security Procedures

Deals with security issues when working with the R&S SMW in secure areas. It is available for download on the Internet.

### 1.2.6 Printed Safety Instructions

Provides safety information in many languages. The printed document is delivered with the product.

### 1.2.7 Data Sheets and Brochures

The data sheet contains the technical specifications of the R&S SMW. It also lists the options and their order numbers and optional accessories.

The brochure provides an overview of the instrument and deals with the specific characteristics.

See [www.rohde-schwarz.com/brochure-datasheet/smw200a](http://www.rohde-schwarz.com/brochure-datasheet/smw200a)

### 1.2.8 Release Notes and Open Source Acknowledgment (OSA)

The release notes list new features, improvements and known issues of the current firmware version, and describe the firmware installation.

The open-source acknowledgment document provides verbatim license texts of the used open source software.

See [www.rohde-schwarz.com/firmware/smw200a](http://www.rohde-schwarz.com/firmware/smw200a)

### 1.2.9 Application Notes, Application Cards, White Papers, etc.

These documents deal with special applications or background information on particular topics.

See [www.rohde-schwarz.com/application/smw200a](http://www.rohde-schwarz.com/application/smw200a) and [www.rohde-schwarz.com/manual/smw200a](http://www.rohde-schwarz.com/manual/smw200a)

## 1.3 Scope



Tasks (in manual or remote operation) that are also performed in the base unit in the same way are not described here.

In particular, it includes:

- Managing settings and data lists, like saving and loading settings, creating and accessing data lists, or accessing files in a particular directory.
- Information on regular trigger, marker and clock signals and filter settings, if appropriate.
- General instrument configuration, such as checking the system configuration, configuring networks and remote operation
- Using the common status registers

For a description of such tasks, see the R&S SMW user manual.

## 1.4 Notes on Screenshots

When describing the functions of the product, we use sample screenshots. These screenshots are meant to illustrate as many as possible of the provided functions and possible interdependencies between parameters. The shown values may not represent realistic usage scenarios.

The screenshots usually show a fully equipped product, that is: with all options installed. Thus, some functions shown in the screenshots may not be available in your particular product configuration.

## 2 About this Digital Standard

CDMA2000 is the North American standard for the third mobile radio generation (3G). It is a further development of the North American mobile radio system of the second-generation IS95 (CDMA).

### Required options

The basic equipment layout for generating CDMA2000 signals includes the options:

- Standard or wideband baseband generator (R&S SMW-B10/-B9)
- Baseband main module (R&S SMW-B13) or wideband baseband main module (R&S SMW-B13XT)
- Option CDMA2000 (R&S SMW-K46)
- Frequency option (e.g. R&S SMW-B1003)

You can generate signals via play-back of waveform files at the signal generator. To create the waveform file using R&S WinIQSIM2, you do not need a specific option.

To play back the waveform file at the signal generator, you have two options:

- Install the R&S WinIQSIM2 option of the digital standard, e.g. R&S SMW-K255 for playing LTE waveforms
- If supported, install the real-time option of the digital standard, e.g. R&S SMW-K55 for playing LTE waveforms

For more information, see data sheet.

### Overview of main CDMA2000 parameters

The R&S SMW generates the CDMA2000 signals with a chip rate of 1,2288 Mcps, corresponding to the so-called "Spreading Rate 1".

The CDMA2000 signal is generated in arbitrary waveform mode, i.e. the signal is first calculated and then output.

The following table gives an overview of parameters of the modulation system CDMA2000.

**Table 2-1: Parameters of the modulation system**

Parameter	Value
Spreading rate	1.2288 MHz
Channel types	Downlink: <ul style="list-style-type: none"> <li>• Forward Pilot (F-PICH)</li> <li>• Sync (F-SYNC)</li> <li>• Paging (F-PCH)</li> <li>• Transmit Diversity Pilot (F-TDPICH)</li> <li>• Auxiliary Pilot (F-APICH)</li> <li>• Auxiliary Transmit Diversity Pilot (F-ATDPCH)</li> <li>• Broadcast (F-BCH)</li> <li>• Quick Paging (F-QPCH)</li> <li>• Common Power Control (F-CPCCH)</li> <li>• Common Assignment (F-CACH)</li> <li>• Forward Common Control (F-CCCH)</li> <li>• Packet Channels</li> <li>• Forward Packet Data Control (F-PDCCH)</li> <li>• Forward Packet Data (F-PDCH)</li> <li>• Traffic Channels</li> <li>• Forward Dedicated Control (F-DCCH)</li> <li>• Forward Fundamental (F-FCH)</li> <li>• Forward Supplemental (F-SCH)</li> </ul> Uplink: <ul style="list-style-type: none"> <li>• Reverse Pilot (R-PICH)</li> <li>• Access (R-ACH)</li> <li>• Enhanced Access (R-EACH)</li> <li>• Reverse Common Control (R-CCCH)</li> <li>• Traffic Channel</li> <li>• Reverse Dedicated Control (R-DCCH)</li> <li>• Reverse Fundamental (R-FCH)</li> <li>• Reverse Supplemental Code (R-SCCH)</li> <li>• Reverse Supplemental (R-SCH)</li> </ul>
Channel count	In downlink 4 base stations each with up to 78 code channels (depending on the radio configuration). In uplink 4 mobile stations with up to 8 code channels (depending on the radio configuration).
Radio configuration	RC 1 – RC 5 & RC10
Frame length	Radio frame: 5 ms, 10 ms, 20 ms, 40 ms, 80 ms, 160 ms (depending on the channel type and the radio configuration)
PN offset	0 ... 511
Quasi Orthogonal Walsh Set	set 1 – set 3
Channel coding	All channel coding modes included in IS-2000 (Frame Quality Indicator, Convolutional Encoder, Turbo Encoder, Symbol Puncture, Interleaver, etc.)
Long Code Mask	0 ... 3FF FFFF FFFF hex

The following sections provide some background information on basic terms and principles used in the CDMA2000 modulation system.

## 2.1 Modulation System CDMA2000

The following simplified diagram is used to explain the system principle of CDMA2000 in the forward (down) and reverse (up) link. The exact system configuration depends on parameters like link direction, spreading rate, mode, radio configuration and channel type. A detailed description cannot be given in this manual. For further information, refer to the IS2000 standard.

### 2.1.1 Modulation System CDMA2000 in the Downlink (Forward)

The following block diagram shows the components of the CDMA2000 transmission system in the downlink.

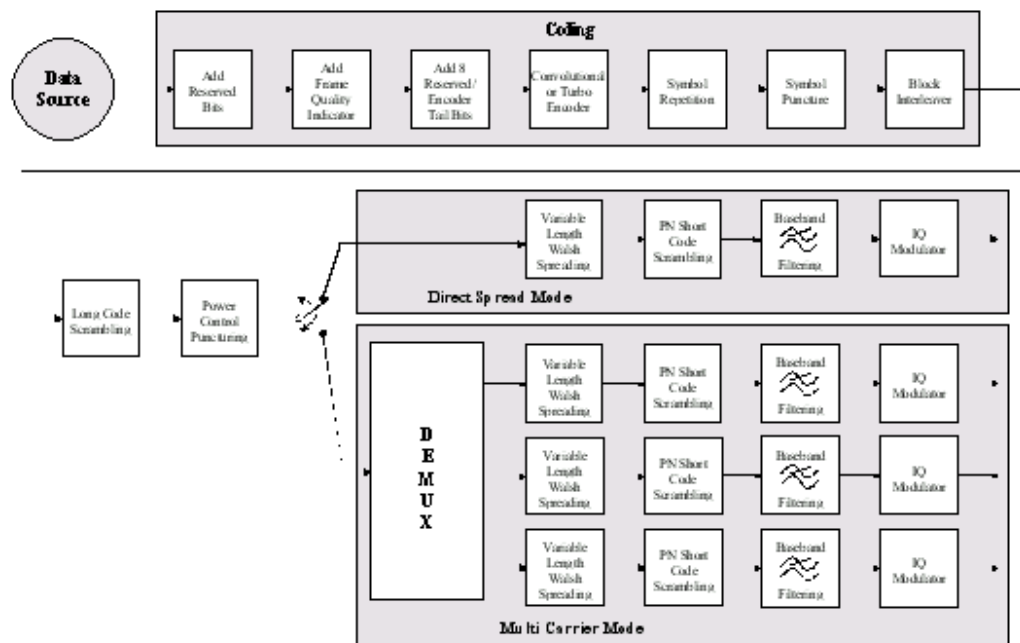

Figure 2-1: Components of the CDMA2000 transmission system in the downlink (forward)

### 2.1.2 Modulation System CDMA2000 in the Uplink (Reverse)

The following block diagram shows the components of the CDMA2000 transmission system in the uplink.

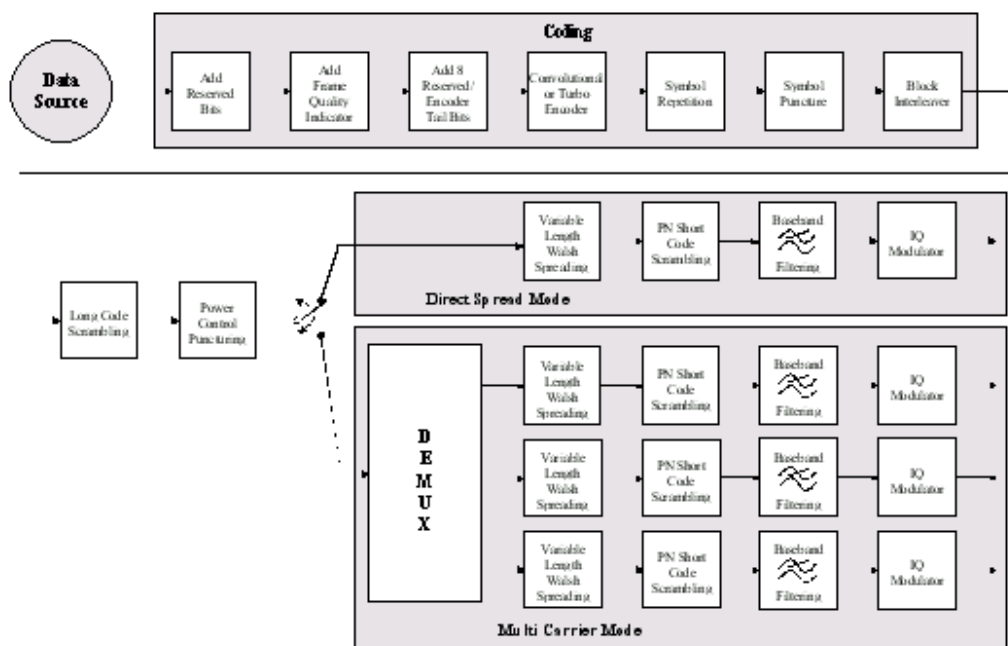

Figure 2-2: Components of the CDMA2000 transmission system in the uplink (reverse)

### 2.1.3 Data Source - Uplink and Downlink

The data fields of all channels can be filled from all possible data sources: pattern (all1, all0, user-defined up to 64 bits), PRBS data, data lists and external data.

### 2.1.4 Channel Coding - Uplink and Downlink

In contrast to 3GPP FDD, channel coding with CDMA2000 is part of the physical layer. The channel coding procedure can slightly vary depending on channel type, frame length and data rate. The basic coding procedure is illustrated by the coding block in the diagram above.

For a more exact definition, refer to the standard.

<b>Add reserved bits:</b>	filled with "0" bits
<b>Add frame quality indicator:</b>	calculation and insertion of a CRC (cyclic redundancy code) checksum for error identification.
<b>Add 8 reserved/encoder</b>	
<b>Tail bits:</b>	reserved, tail bits which set the subsequent coder to a defined final state.
<b>Convolutional or turbo encoder:</b>	error correction code, depending on data rate and other parameters either by convolutional coding or turbo codes.

<b>Symbol repetition:</b>	symbol repetition is used together with block symbol puncture for adapting the convolutional or turbo coder output data rate to the required input data rate of the interleaver.
<b>Symbol puncture:</b>	symbol puncturing (elimination) is used together with block symbol repetition for adapting the convolutional or turbo coder output data rate to the required input data rate of the interleaver.
<b>Block interleaver:</b>	block-wise permutation of input data sequence of interleaver to reduce bit errors.

### 2.1.5 Long-Code Scrambling Generator - Downlink

The long-code generator is also referred to as scrambling code generator since it scrambles the chip sequence in a user-specific way (long-code mask).

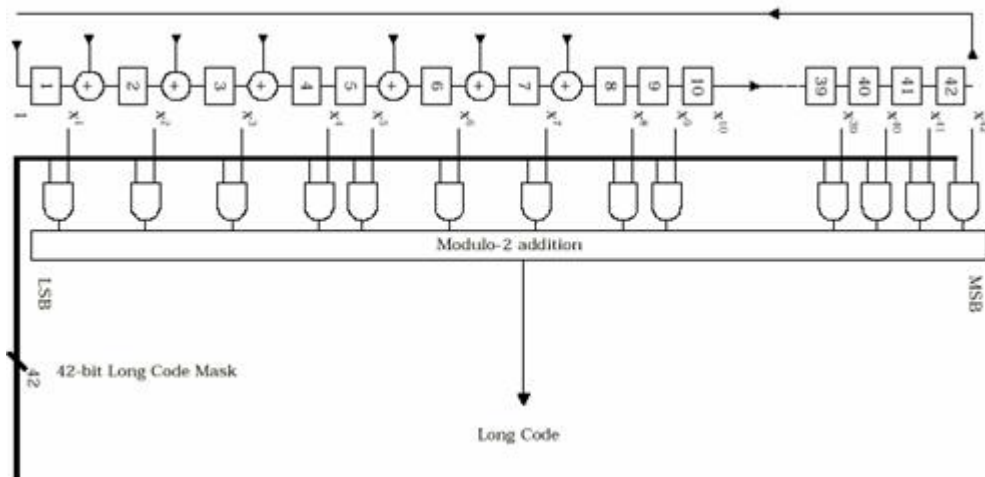

Figure 2-3: Long-code generator CDMA2000

The long-code generator is a feedback 42-bit shift register with its status vector linked to a user-specific long-code mask to form the specific long-code sequence.

The generator polynomial of the shift-register section of the long-code generator is:

$$p(x) = x^{42} + x^{35} + x^{33} + x^{31} + x^{27} + x^{26} + x^{25} + x^{22} + x^{21} + x^{19} + x^{18} + x^{17} + x^{16} + x^{10} + x^7 + x^6 + x^5 + x^3 + x^2 + x^1 + 1$$

A real long code is used in the forward link. In the reverse link, a complex long code with I and Q component is required. The long code for the I component is derived directly from the 1X generator, that for the Q component corresponds to the I long code delayed by one chip.

### 2.1.6 Power Control Puncturing - Downlink

To control the output power of the mobile station, the BS sends power control bits in the traffic channel at an 800 Hz rate instead of the scrambled data bits. Depending on the power control bits, the mobile station increases or reduces its output power.

### 2.1.7 Variable-Length Walsh Spreading - Downlink

Spreading of the CDMA2000 signal is performed in this block. Walsh codes with a variable spreading factor are used. The spreading factor and the Walsh code depend on the spreading rate, channel type, frame length and data rate. To extend the base-station capacity, so-called 'quasi-orthogonal Walsh sets' can be used in addition to the Walsh codes. The input data stream of the spreading unit is already complex ( $I + jQ$ ). If a standard Walsh code is used, spreading is performed by multiplying the input symbol (modulo 2 multiplication) with the real Walsh code. The quasi-orthogonal Walsh code results in complex spreading through an additional rotation of the output phase (the spreading code then consists of a real and an imaginary part).

### 2.1.8 PN Short-Code Scrambling - Downlink

The (complex) input data stream of the PN short-code scrambler is multiplied by a complex PN sequence ( $I_{PN} + j Q_{PN}$ ). This is also called 'quadrature spreading'. With channels of the radio configurations 1 and 2, whose generation is comparable with that of IS-95 systems, this block splits up the input stream in I and Q components.

The base-station-specific parameter PN offset determines the start phase of these PN short-code sequences. This permits signals of different base stations to be distinguished.

Generator polynomial for I and Q components of the PN short code:

$$P_I(x) = x^{15} + x^{13} + x^9 + x^8 + x^7 + x^5 + 1$$

$$P_Q(x) = X^{15} + x^{12} + x^{11} + x^{10} + x^6 + x^5 + x^4 + x^3 + 1$$

The period of a PN short-code sequence is 26.666 ms.

### 2.1.9 Spreading - Uplink

Increasing the data rate or spreading in the reverse link is performed in different ways depending on the radio configuration and the channel type.

#### 2.1.9.1 Variable Length Walsh Spreading

Walsh codes with a variable spread factor are used for spreading. The spreading factor and the Walsh code depend on the spreading rate, channel type, frame length and the data rate. Spreading is obtained by multiplication of the input symbol (modulo 2 multiplication) by the real Walsh code.

#### 2.1.9.2 64-Ary Orthogonal Modulator

Groups of 6 input bits are used for addressing a line of the Walsh code table with the spread code length of 64. This 'modulator' increases the data rate by a factor of 64/6.

This type of rate increase comes from IS-95 and is used in the radio configurations 1 and 2.

### 2.1.10 Scrambling - Uplink

In the scrambling block of the uplink system, the spread data stream is scrambled with the long code and the PN short code. Different methods are used for the radio configurations 1, 2 and RC3 to RC5.

#### 2.1.10.1 Scrambling for Radio Configuration 1 and 2

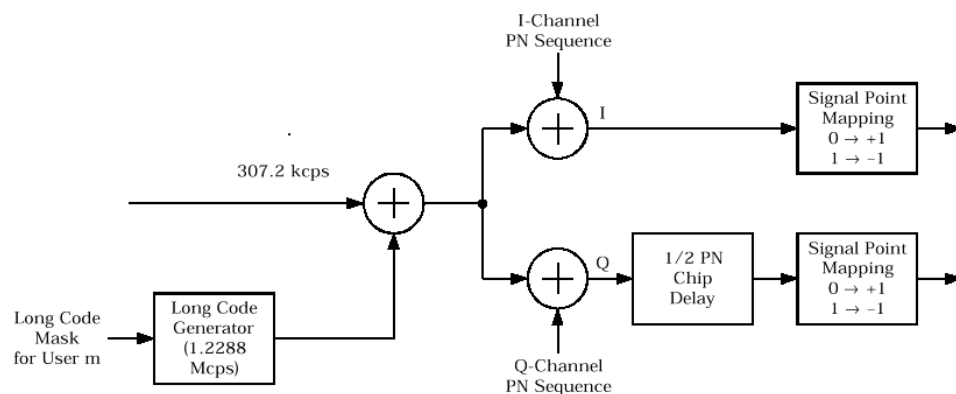

Figure 2-4: Scrambling in the uplink RC 1 and RC2

The output data stream of the spreading block is scrambled with the **long code**. The rate is increased in addition by a factor of four. The long-code generator is also referred to as scrambling code generator since it scrambles the chip sequence in a user-specific way (long-code mask). This generator exactly corresponds to the generation described in [Chapter 2.1.5, "Long-Code Scrambling Generator - Downlink"](#), on page 15 for the downlink.

The real input data stream of the **PN short-code** scrambler is multiplied by a complex PN sequence ( $I_{PN} + j Q_{PN}$ ). This procedure is also called 'quadrature spreading'. With channels of the radio configurations 1 and 2, whose generation is comparable with that of IS-95 systems, this block splits up the input stream in I and Q components.

In contrast to the downlink, no variable PN offset parameter is available for the PN short code in the reverse link. The PN offset is always 0.

Different generation rules are used for the PN short codes depending on the mode and spreading rate. The generator polynomials of the PN short codes correspond to the polynomials in the downlink (see [Chapter 2.1.8, "PN Short-Code Scrambling - Downlink"](#), on page 16). The I and Q data streams consisting of {0, 1} sequences are then mapped to {+1, -1} in the **signal point mapping** block.

Because of the delay of the Q component, offset QPSK constellation known from the reverse link of IS-95 is obtained from the QPSK constellation. Due to the Q delay, the transfer of the I and Q signal components from one chip to the next is never synchro-

nous. For this reason, there are no zero crossings in the transfer from one chip to the next. This behavior can be seen in the vector diagram below.

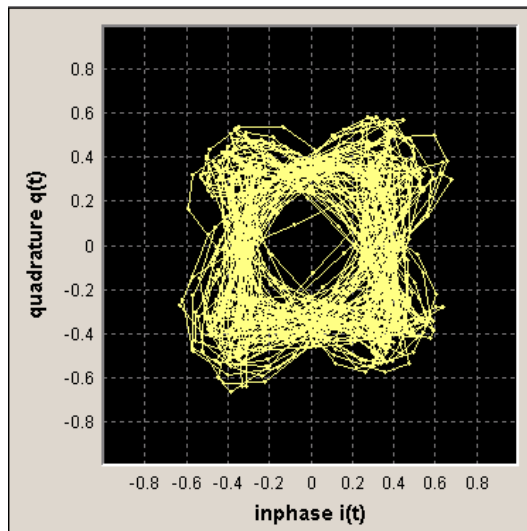

Figure 2-5: Scrambling in the uplink RC 1 and RC2

### 2.1.10.2 Scrambling for Radio Configuration 3, 4 and 5

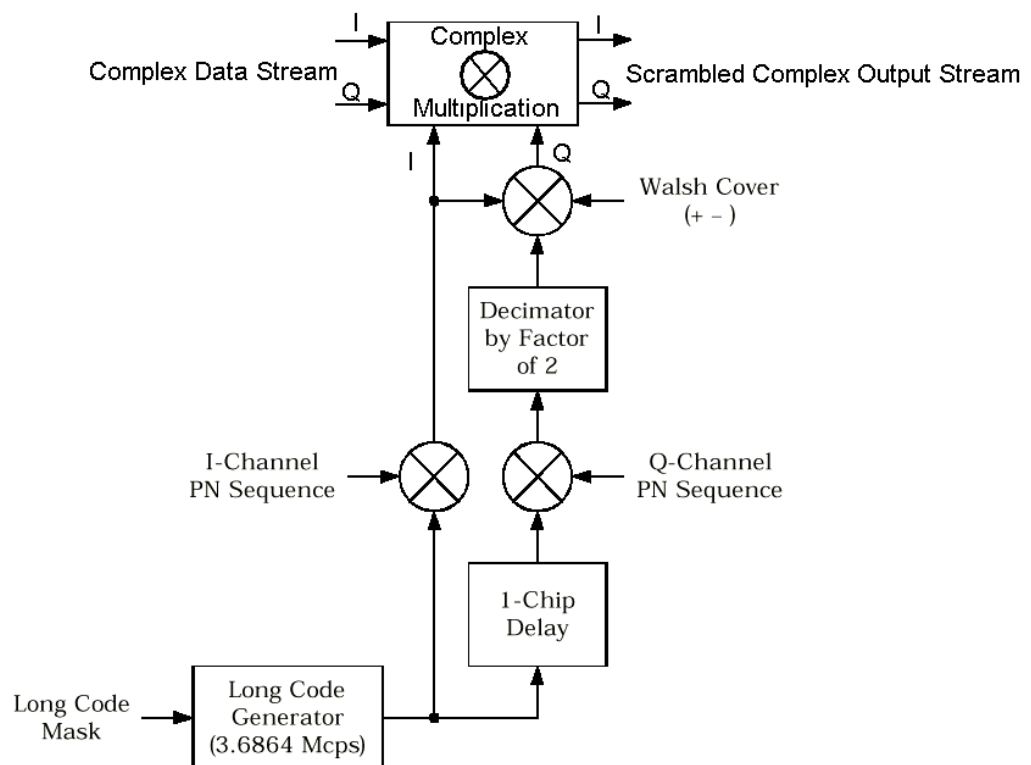

Figure 2-6: Scrambling in the uplink RC3, RC4 and RC5

Here too, the long-code generator defined in [Chapter 2.1.5, "Long-Code Scrambling Generator - Downlink"](#), on page 15 for the downlink is used. A complex long-code sequence is required. For this purpose, the output sequence of the generator is used as the I component and the sequence delayed by one chip as the Q component.

The I component of the long code is then multiplied by the I component of the PN short code. The same applies for the Q component. The definition of the PN short code is given in [Chapter 2.1.8, "PN Short-Code Scrambling - Downlink"](#), on page 16.

The subsequent operations decimate by factor of 2 and link the Q component to the Walsh sequence (+-) and the I component. They serve for reducing the zero crossings of the I/Q signal at the end of the whole scrambling process. Thus a behavior similar to behavior in the uplink of 3GPP is obtained. It is also known as **HPSK** (hybrid phase shift keying).

The resulting I/Q output stream is obtained by complex multiplication (modulo 2) of the I/Q input sequence of the scrambler by the complex scramble sequence. The complex scramble sequence is obtained from the long code and the PN short code. The constellation obtained is a combination of QPSK and offset QPSK.

In this mode, the traffic data streams of a channel are mapped either to the I or to the Q path of the complex data stream (see [Figure 2-6](#)). With these so-called BPSK channels, the channel component at the scrambler input consists of a real or an imaginary component. As can be seen in the table below, the constellation after complex scrambling is again at the angle bisector.

**Table 2-2: Output combinations with BPSK channels**

$d(n) \setminus S\text{-Code}(n)$	-1-j	-1+j	+1-j	+1+j
-1	+1+j	+1-j	-1+j	-1-j
+1	-1-j	-1+j	+1-j	+1+j
-j	-1+j	+1+j	-1-j	+1-j
+j	+1-j	-1-j	+1+j	-1+j

### 2.1.11 Baseband Filtering - Uplink and Downlink

This block performs baseband filtering (pulse shaping and band limiting) of the I/Q signal. In addition to the filters specified in the standard, the signal generator also provides equalizer filters with a better adjacent-channel leakage ratio.

### 2.1.12 I/Q Modulator - Uplink and Downlink

The I/Q modulator defined in the IS2000 standard differs from the definition in this implementation. The definition on which the implementation is based is used by virtually all digital communication standards, except IS95 and IS2000.

In the final step, the filtered IQ signal is modulated to the desired RF in a different way in the I/Q modulator:

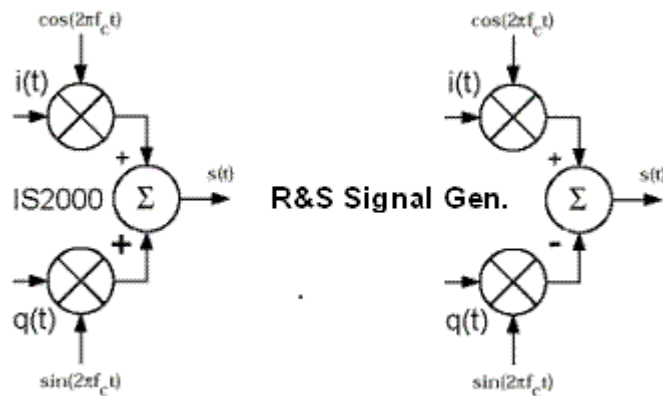

Figure 2-7: Definition of I/Q modulator in IS2000 and the R&S SMW

IS2000 = the RF signal  $s(t)$  is derived from the baseband I/Q signal as  $s(t) = i(t)\cos(2\pi f_c t) + q(t)\sin(2\pi f_c t)$

R&S SMW = the RF signal  $s(t)$  is based on the definition  $s(t) = i(t)\cos(2\pi f_c t) - q(t)\sin(2\pi f_c t)$

To generate baseband signals according to IS2000 (CDMA200 standard) invert the Q-part of the signal, i.e. select "I/Q Modulator > I/Q Swap > On".

See also R&S SMW user manual, section "Applying I/Q Vector Modulation".

### 2.1.13 Constellation of I/Q Signals - Downlink

Depending on radio configuration and channel type, the signal components in the different channels create different subconstellations.

#### 2.1.13.1 BPSK Channels

With some channel types (in RC1/2 and in the pilot channel), the data stream is split up in I and Q components in the **PN short code scrambling** block. The input data stream of this block is a real +/-1 sequence similar to BPSK. The complex output data sequence is then as follows:

$$S_{\text{out}}(n) = d_{\text{in}}(n) (PN_I(n) + j PN_Q(n)), \text{ with } d_{\text{in}}(n), PN_I(n), PN_Q(n) \in \{-1, +1\}.$$

This yields four different output combinations for  $S_{\text{out}}$ :

$$(-1 -j), (-1 +j), (+1 -j), (+1 +j),$$

i.e. all points are on one of the two angle bisectors at the I/Q level.

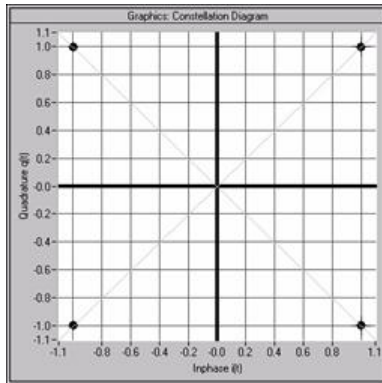

Figure 2-8: Constellation diagram of a BPSK channel with 0 dB power

### 2.1.13.2 QPSK Channels

With other channel types, the input data stream of the **PN short code scrambling** block is a complex  $\pm 1 \pm j$  sequence similar to QPSK. The complex output data sequence is then as follows:

$$S_{\text{out}}(n) = (d_I(n) + jd_Q(n)) (PN_I(n) + j PN_Q(n)), \text{ with } d_I(n), d_Q(n), PN_I(n), PN_Q(n) \in \{-1, +1\}.$$

Table 2-3: Output combinations with QPSK channels

PN(n) \ d(n)	-1-j	-1+j	+1-j	+1+j
-1-j	+2j	+2	-2	-2j
-1+j	+2	-2j	+2j	-2
+1-j	-2	+2j	-2j	+2
+1+j	-2j	-2	+2	+2j

This again yields four different output combinations for  $S_{\text{out}}$ :

-2j, 2j, -2, 2,

i.e. all points are on one of the two axes at the I/Q level.

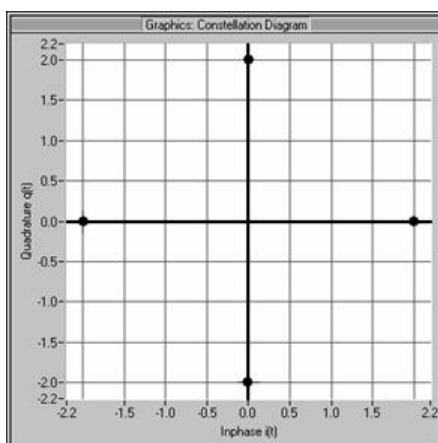

Figure 2-9: Constellation diagram of a QPSK channel with 0 dB power

### 2.1.14 Power Control - Downlink and Uplink

After spreading and scrambling, a channel-specific power factor  $p$  is applied to the signal. For example, a value of -6 dB therefore results in half the level (or 1/4 power).

## 3 CDMA2000 Configuration and Settings

- ▶ To access the CDMA2000 settings, select "Baseband > CDMA2000".

**Tip:** The dialog is comprehensive. To simplify the description and the orientation through this documentation, the headings of the following section follow a common naming convention:

<DialogName/TabName>< - ><SourceDialog>

This common structure is intended to identify your current location in the dialog.

The remote commands required to define these settings are described in [Chapter 4](#), "Remote-Control Commands", on page 83.

• <a href="#">General Settings for CDMA2000 Signals</a> .....	23
• <a href="#">Trigger Settings</a> .....	26
• <a href="#">Marker Settings</a> .....	31
• <a href="#">Clock Settings</a> .....	32
• <a href="#">Local and Global Connector Settings</a> .....	34
• <a href="#">CDMA2000 Basestations and Mobile Stations Settings</a> .....	34
• <a href="#">Filter / Clipping / ARB Settings</a> .....	78

### 3.1 General Settings for CDMA2000 Signals

This tab provides access to the default and the "Save/Recall" settings, and displays the valid CDMA2000 version and the spreading rate. The selected link direction determines the available parameters.

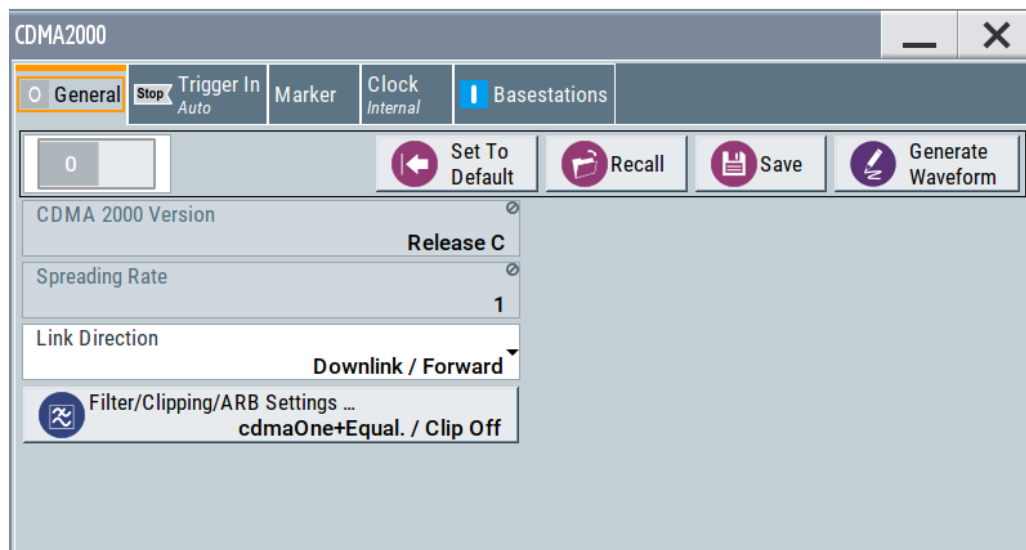

<a href="#">State</a> .....	24
<a href="#">Set to Default</a> .....	24
<a href="#">Save/Recall</a> .....	25
<a href="#">Generate Waveform File</a> .....	25

CDMA 2000 Version.....	25
Spreading Rate.....	25
Link Direction.....	25
Filter / Clipping / ARB Settings.....	26

### State

Activates the standard and deactivates all the other digital standards and digital modulation modes in the same path.

Remote command:

[ :SOURce<hw> ] :BB:C2K:STATe on page 90

### Set to Default

Calls the default settings. The values of the main parameters are listed in the following table.

Parameter	Value
State	Not affected by "Set to default"
Link Direction	Downlink
Filter	CdmaOne + Equalizer
Clipping	Off
Trigger	Auto
Clock	Internal
<b>Base Station Configuration</b>	
State	Off
Radio Configuration Traffic Channels 1 and 2	RC3
Radio Configuration other Traffic Channels	RC1
Time Delay	0 chips
PN Offset	0
Transmit Diversity	Off
Quasi Orthogonal Walsh Set	1
<b>Mobile Station Configuration</b>	
State	Off
Mode	Traffic
Radio Configuration	RC3
Channel Coding	Complete
LC Mask (hex)	0
State (all Channels)	Off
Power Control	Off

Remote command:

[ :SOURce<hw> ] :BB:C2K:PRESet on page 88

### Save/Recall

Accesses the "Save/Recall" dialog, that is the standard instrument function for saving and recalling the complete dialog-related settings in a file. The provided navigation possibilities in the dialog are self-explanatory.

The settings are saved in a file with predefined extension. You can define the filename and the directory, in that you want to save the file.

See also, chapter "File and Data Management" in the R&S SMW user manual.

Remote command:

[ :SOURce<hw> ] :BB:C2K:SETTing:CATalog? on page 88

[ :SOURce<hw> ] :BB:C2K:SETTing:LOAD on page 89

[ :SOURce<hw> ] :BB:C2K:SETTing:STORe on page 89

[ :SOURce<hw> ] :BB:C2K:SETTing:DELete on page 88

### Generate Waveform File

With enabled signal generation, triggers the instrument to save the current settings of an arbitrary waveform signal in a waveform file with predefined extension \* .wv. You can define the filename and the directory, in that you want to save the file.

Using the ARB modulation source, you can play back waveform files and/or process the file to generate multi-carrier or multi-segment signals.

Remote command:

[ :SOURce<hw> ] :BB:C2K:WAVEform:CREate on page 90

### CDMA 2000 Version

Displays the current version of the CDMA2000 standard.

The default settings and parameters provided are oriented towards the specifications of the version displayed.

Remote command:

[ :SOURce ] :BB:C2K:VERSion? on page 90

### Spreading Rate

Displays the spreading rate.

Mode Spreading Rate 1 ("Direct Spread 1X") is used:

The "Chip Rate" parameter which determines the rate of the spread symbols that is used for signal output, can be varied in the Filter, Clipping, ARB Settings dialog (see [Chapter 3.7, "Filter / Clipping / ARB Settings"](#), on page 78 ).

Remote command:

[ :SOURce<hw> ] :BB:C2K:CRATe? on page 86

### Link Direction

Selects the transmission direction.

The settings of the base station or the mobile station are provided in the following dialog section in accordance with the selection.

**"Downlink/ Forward Link"**

The transmission direction selected is base station to mobile station.  
The signal corresponds to that of a base station.

**"Uplink/ Reverse Link"**

The transmission direction selected is mobile station to base station.  
The signal corresponds to that of a mobile station.

Remote command:

[ :SOURce<hw> ] :BB:C2K:LINK on page 87

**Filter / Clipping / ARB Settings**

Provides access to the dialog for setting baseband filtering, clipping and the sequence length of the arbitrary waveform component, see [Chapter 3.7, "Filter / Clipping / ARB Settings"](#), on page 78.

## 3.2 Trigger Settings

This dialog provides access to the settings necessary to select and configure the trigger, like trigger source, mode, trigger delay and trigger suppression, as well as to arm or trigger an internal trigger manually. The current signal generation status is displayed in the header of the dialog together with information on the enabled trigger mode. As in the "Marker" and "Clock" dialogs, this dialog provides also access to the settings of the related connectors.



This section focuses on the available settings.

For information on how these settings affect the signal, refer to section "Basics on ..." in the R&S SMW user manual.

- ▶ To access this dialog, select "Baseband > CDMA2000 > Trigger In".

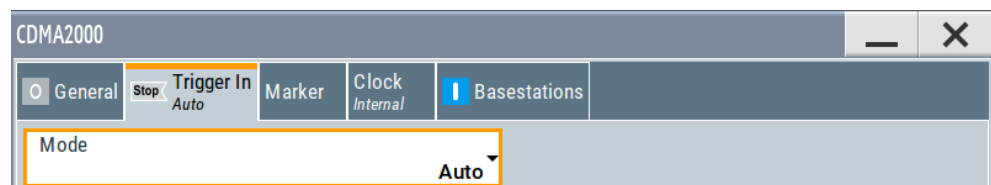

This dialog comprises the settings required for configuring the trigger signal.



### Routing and enabling a trigger

The provided trigger signals are not dedicated to a particular connector. Trigger signals can be mapped to one or more USER x or T/M connectors.

Use the [Local and Global Connector Settings](#) to configure the signal mapping, the polarity, the trigger threshold and the input impedance of the input connectors.

To route and enable a trigger signal, perform the following *general steps*:

- Define the signal source and the effect of a trigger event.  
Select the "Trigger In > Mode" and "Trigger In > Source".
- Define the connector where the selected signal is provided.  
Use the "Global Connectors" settings.

Provided are the following settings:

### Trigger Settings Common to All Basebands

To enable simultaneous signal generation in all basebands, the R&S SMW couples the trigger settings in the available basebands in any instrument's configuration involving signal routing with signal addition. For example, in MIMO configuration, routing and summing of basebands or of streams.

The icon  indicates that common trigger settings are applied.

You can access and configure the common trigger source and trigger mode settings in any of the basebands. An arm or a restart trigger event applies to all basebands, too. You can still apply different delay to each of the triggers individually.

### Trigger Mode

Selects trigger mode, i.e. determines the effect of a trigger event on the signal generation.

For more information, refer to chapter "Basics" in the R&S SMW user manual.

- "Auto"  
The signal is generated continuously.
- "Retrigger"  
The signal is generated continuously. A trigger event (internal or external) causes a restart.
- "Armed Auto"  
The signal is generated only when a trigger event occurs. Then the signal is generated continuously.  
An "Arm" stops the signal generation. A subsequent trigger event (internal or external) causes a restart.
- "Armed Retrigger"  
The signal is generated only when a trigger event occurs. Then the signal is generated continuously. Every subsequent trigger event causes a restart.  
An "Arm" stops signal generation. A subsequent trigger event (internal or external) causes a restart.
- "Single"  
The signal is generated only when a trigger event occurs. Then the signal is generated once to the length specified at "Signal Duration".  
Every subsequent trigger event (internal or external) causes a restart.

Remote command:

[\[:SOURce<hw>\]:BB:C2K\[:TRIGger\]:SEQuence](#) on page 96

### Signal Duration Unit

Defines the unit for describing the length of the signal sequence to be output in the "Single" trigger mode.

Available units are chip sequence length (CLS), chips or frames.

Remote command:

[\[:SOURce<hw>\]:BB:C2K:TRIGger:SLUNit](#) on page 99

### Trigger Signal Duration

Enters the length of the signal sequence to be output in the "Single" trigger mode.

Use this parameter to output part of the signal deliberately, an exact sequence of the signal, or a defined number of repetitions of the signal.

Remote command:

[\[:SOURce<hw>\]:BB:C2K:TRIGger:SLENgth](#) on page 99

### Running/Stopped

With enabled modulation, displays the status of signal generation for all trigger modes.

- "Running"  
The signal is generated; a trigger was (internally or externally) initiated in triggered mode.
- "Stopped"  
The signal is not generated and the instrument waits for a trigger event.

Remote command:

[\[:SOURce<hw>\]:BB:C2K:TRIGger:RMODE?](#) on page 98

### Arm

Stops the signal generation until subsequent trigger event occurs.

Remote command:

[\[:SOURce<hw>\]:BB:C2K:TRIGger:ARM:EXECute](#) on page 97

### Execute Trigger

For internal trigger source, executes trigger manually.

Remote command:

[\[:SOURce<hw>\]:BB:C2K:TRIGger:EXECute](#) on page 97

### Trigger Source

The following sources of the trigger signal are available:

- "Internal"  
The trigger event is executed manually by the "Execute Trigger".
- "Internal (Baseband A/B)"  
The trigger event is provided by the trigger signal from the other basebands. If common trigger settings are applied, this trigger source is disabled.
- "External Global Trigger"  
The trigger event is the active edge of an external trigger signal provided and configured at the USER x connectors.

- "External Local Trigger"  
The trigger event is the active edge of an external trigger signal provided and configured at the local T/M/C connector.  
With coupled trigger settings, the signal has to be provided at the T/M/C1/2/3 connectors.
- "External Local Clock"  
The trigger event is the active edge of an external local clock signal provided and configured at the local T/M/C connector.  
With coupled trigger settings, the signal has to be provided at the T/M/C1 connector.
- "Baseband Sync In"  
Option: R&S SMW-B9  
In master-slave mode, slave instruments are triggered by the active edge of the synchronization signal.

"External Local Clock/Trigger" require R&S SMW-B10.

Remote command:

`[ :SOURce<hw> ] :BB:C2K:TRIGger:SOURce` on page 96

### Sync. Output to External Trigger/Sync. Output to Trigger

Enables signal output synchronous to the trigger event.

- "On"  
Corresponds to the default state of this parameter.  
The signal calculation starts simultaneously with the trigger event. Because of the processing time of the instrument, the first samples are cut off and no signal is output. After elapsing of the internal processing time, the output signal is synchronous to the trigger event.

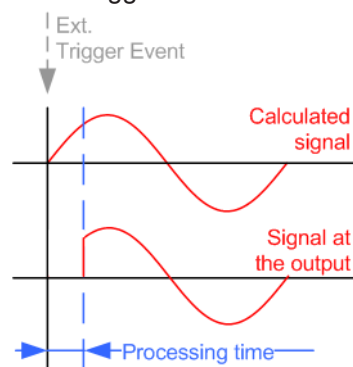

- "Off"  
The signal output begins after elapsing of the processing time. Signal output starts with sample 0. The complete signal is output.  
This mode is recommended for triggering of short signal sequences. Short sequences are sequences with signal duration comparable with the processing time of the instrument.

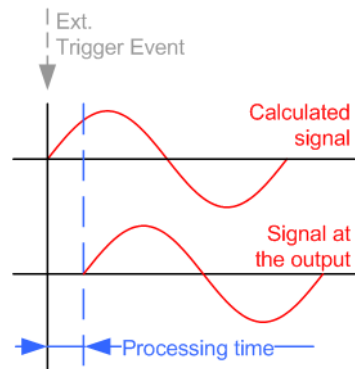

In master-slave mode, this setting ensures that once achieved, synchronization is not lost if the baseband signal sampling rate changes.

Remote command:

`[ :SOURce<hw> ] :BB:C2K:TRIGger:EXTernal:SYNChronize:OUTPut`  
on page 97

### External Trigger Inhibit

Applies for external trigger signal or trigger signal from the other path.

Sets the duration with that any following trigger event is suppressed. In "Retrigger" mode, for example, a new trigger event does not cause a restart of the signal generation until the specified inhibit duration does not expire.

For more information, see chapter "Basics" in the R&S SMW user manual.

Remote command:

`[ :SOURce<hw> ] :BB:C2K:TRIGger [ :EXTernal ] :INHibit` on page 98  
`[ :SOURce<hw> ] :BB:C2K:TRIGger:OBASeband:INHibit` on page 98

### Trigger Delay

Delays the trigger event of the signal from:

- The external trigger source
- The other path
- The other basebands (internal trigger), if common trigger settings are used.

Use this setting to:

- Synchronize the instrument with the device under test (DUT) or other external devices
- Postpone the signal generation start in the basebands compared to each other
- Compensate delays and align the signal generation start in multi-instrument setup

For more information, see chapter "Basics on ..." in the R&S SMW user manual.

Remote command:

`[ :SOURce<hw> ] :BB:C2K:TRIGger [ :EXTernal ] :DELay` on page 98  
`[ :SOURce<hw> ] :BB:C2K:TRIGger:OBASeband:DELay` on page 97

### 3.3 Marker Settings

This dialog provides access to the settings necessary to select and configure the marker output signal, like the marker mode or marker delay settings.



This section focuses on the available settings.

For information on how these settings affect the signal, refer to section "Basics on ..." in the R&S SMW user manual.

- ▶ To access this dialog, select "Baseband > CDMA2000 > Marker".



This dialog comprises the settings required for configuring the marker mode and the marker delay.



#### Routing and enabling a marker

The provided marker signals are not dedicated to a particular connector. They can be mapped to one or more USER x or T/M connectors.

To route and enable a marker signal, perform the following *general steps*:

- Define the shape of the generated marker, i.e. select the "Marker > Mode".
- Define the connector where the selected signal is provided.  
Use the [Local and Global Connector Settings](#).

#### Settings:

##### Marker Mode

Marker configuration for up to 3 markers. The settings are used to select the marker mode defining the shape and periodicity of the markers. The contents of the dialog change with the selected marker mode.

"Power Control Group (1.25 ms)"

A marker signal is generated at the start of each Power Control Group (every 1.25 ms).

**"Radio Frame (20 ms)"**

A marker signal is generated every 20 ms (traffic channel frame clock).

**"Sync Channel Frame (26.6 ms)"**

A marker signal is generated at the beginning of each Sync Channel Frame (every 26.6 ms).

**"Superframe (80 ms)"**

A marker signal is generated every 80 ms (super frame clock).

**"Even Second Mark (2 s)"**

A marker signal is generated every 2 seconds.

**"Chip Sequence Period (ARB)"**

A marker signal is generated at the beginning of every Arbitrary Waveform sequence (depending on the set sequence length). The marker signal is generated regardless of whether an ARB component is used.

**"ON/OFF Period"**

A regular marker signal that is defined by an ON/OFF ratio is generated. A period lasts one ON and OFF cycle.

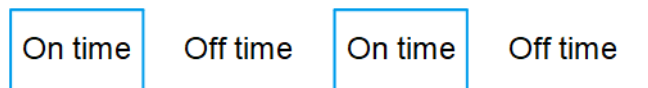

Remote command:

[\[:SOURCE<hw>\]:BB:C2K:TRIGGER:OUTPUT<ch>:ONTime](#) on page 100

[\[:SOURCE<hw>\]:BB:C2K:TRIGGER:OUTPUT<ch>:OFFTime](#) on page 100

**"User Period"** A marker signal is generated at the beginning of every user-defined period. The period is defined in "Period".

Remote command:

[\[:SOURCE<hw>\]:BB:C2K:TRIGGER:OUTPUT<ch>:PERIOD](#) on page 100

Remote command:

[\[:SOURCE<hw>\]:BB:C2K:TRIGGER:OUTPUT<ch>:MODE](#) on page 99

**Marker x Delay**

Delays the marker signal at the marker output relative to the signal generation start.

Variation of the parameter "Marker x Delay" causes signal recalculation.

Remote command:

[\[:SOURCE<hw>\]:BB:C2K:TRIGGER:OUTPUT<ch>:DELAY](#) on page 101

## 3.4 Clock Settings

This tab provides access to the settings necessary to select and configure the clock signal, like the clock source and clock mode.



This section focuses on the available settings.

For information on how these settings affect the signal, refer to section "Basics on ..." in the R&S SMW user manual.

- ▶ To access this dialog, select "Baseband > CDMA2000 > Clock".

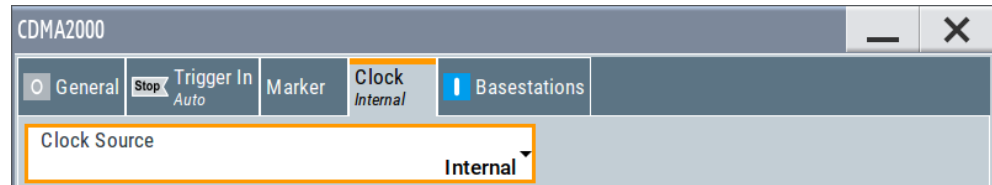

This dialog comprises the settings required for configuring the clock signal.



### Defining the clock

The provided clock signals are not dedicated to a particular connector. They can be mapped to one or more USER x and T/M/C connectors.

Use the [Local and Global Connector Settings](#) to configure the signal mapping, the polarity, the trigger threshold, and the input impedance of the input connectors.

To route and enable a trigger signal, perform the following *general steps*:

- Define the signal source, that is select the "Clock > Source".
- Define the connector where the selected signal is provided.  
Use the [Local and Global Connector Settings](#).

#### Clock Source

Selects the clock source.

- "Internal"  
The instrument uses its internal clock reference.
- "External Local Clock"  
Option: R&S SMW-B10  
The instrument expects an external clock reference at the local T/M/C connector.

"External Local Clock" requires R&S SMW-B10.

Remote command:

[ :SOURce<hw> ] :BB:C2K:CLOCK:SOURce on page 102

#### Clock Mode

Option: R&S SMW-B10

Sets the type of externally supplied clock.

Remote command:

[ :SOURce<hw> ] :BB:C2K:CLOCK:MODE on page 101

#### Measured External Clock

Provided for permanent monitoring of the enabled and externally supplied clock signal.

Remote command:

CLOCK:INPut:FREQuency?

## 3.5 Local and Global Connector Settings

Each of the "Trigger In", "Marker" and "Clock" dialogs and the "Trigger Marker Clock" dialog provides a quick access to the related connector settings.



See also chapter "Local and Global Connector Settings" in the user manual.

## 3.6 CDMA2000 Basestations and Mobile Stations Settings

Depending on the selected transmission direction, the last dialog contains either the "Basestations" or the "Mobile Stations" common settings.

### 3.6.1 Configure Base Station or Mobile Station

#### How to configure the base stations settings

Access:

1. Select "CDMA 2000 > General > Transmission Direction > Downlink / Forward".
2. Select the "Base Stations" dialog.

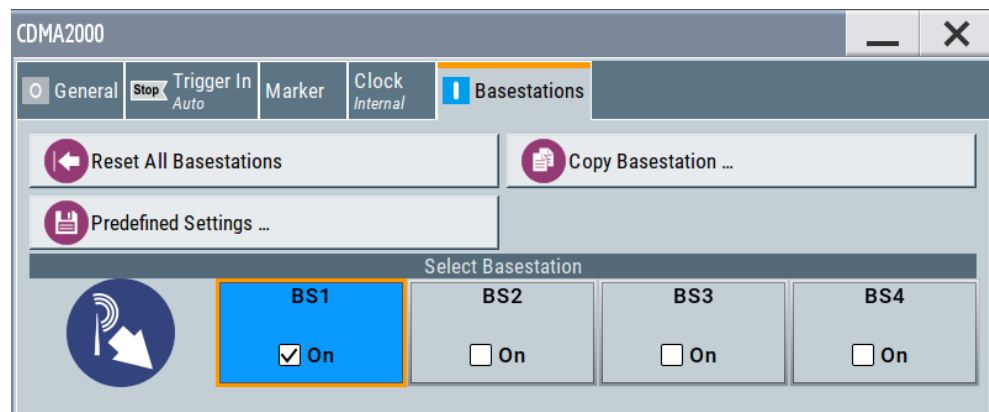

This dialog provides access to the appropriate settings dialogs for configuring the base stations.

#### How to configure the mobile stations settings

1. To access the mobile stations settings, select "CDMA 2000 > General > Link Direction > Uplink / Reverse".

2. Select the "Mobile Stations" dialog.

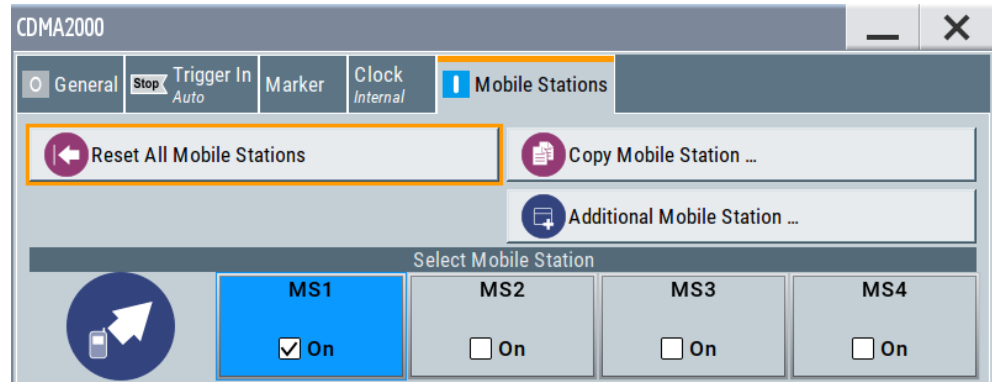

Provides access to the appropriate settings dialogs for configuring the mobile stations.

### Reset All Base Stations

Resets all base stations to the predefined settings. The following table gives an overview of the settings. The preset value for each parameter is specified in the description of the remote-control commands.

Parameter	Value
<b>Base Station Configuration</b>	
State	Off
Time Delay	0 chips
PN Offset	0
Transmit Diversity	Off
Quasi-orthogonal Walsh set	1
State (all channels)	Off
Frame Length (0-5 / 0-7 / 0-10)	26.6 ms / 40 ms / 5 ms
Frame Length (all other channels)	20 ms
Data Rate (0-6,0-10,0-11,1-1,1-4,2-1,2-4)	9.6 kbps
Data Rate (0-7,0-9,1-2,1-3,2-2,2-3)	19.2 kbps
Data Rate (all other channels)	1.2 kbps
Walsh (0-2 / 0-5)	16 / 32
Walsh (1-1 / 1-2 / 1-3 / 2-1 / 2-2 / 2-3)	8 / 17 / 18 / 9 / 19 / 20
Walsh (all other channels)	0
Power (0-1 / 0-6 )	-7 dB / -6.62 dB
Power (0-5 , 1-1, 2-1 / 1-2, 1-3, 2-2, 2-3)	-12.72 dB / -9.72 dB
Power (all other channels)	0 dB
Data Source (0-1, 0-2, 0-3, 0-4)	All0

Parameter	Value
Data Source (all other channels)	PN9
Channel Coding (all Channels)	Complete

Remote command:

[\[:SOURCE<hw>\]:BB:C2K:BSTation:PRESet](#) on page 109

### Reset All Mobile Stations

Resets all mobile stations to the predefined settings. The following table gives an overview of the settings. The preset value for each parameter is specified in the description of the remote-control commands.

Parameter	Value
Mobile Station Configuration	
State	Off
Mode	Traffic
Radio Configuration	3
Channel Coding	Complete
LC Mask (hex)	0
State (all Channels)	Off
Frame Length	20 ms
Data Rate (2 / 3, 4, 5)	9.6 kbps / 1.5 kbps
Walsh (0 / 8 / 4 / 2 / 6)	0 / 8 / 4 / 2 / 6
Spread (2 / 3, 4, 5)	32 / 16
Power	0 dB
Data Source	PN9

Remote command:

[\[:SOURCE<hw>\]:BB:C2K:MSTation:PRESet](#) on page 139

### Copy ...

Copies the settings of a base or mobile station to a second base or mobile station. A window opens for creating the destination station.

"Downlink / Forward" link direction	"Uplink / Reverse"

#### "Copy from Source"

Selects the base station or mobile station whose settings are to be copied.

**"To Destination"**

Selects the base station or mobile station whose settings are to be overwritten.

**"Walsh Code Offset (Base Station only)"**

Enters the offset to be applied when copying the base station to the Walsh codes of the destination base station. The minimum value is 0 (Walsh codes are identical), the maximum value is 255.

**"Accept"**

Starts the copy process.

Remote command:

[ :SOURce<hw> ] :BB:C2K:COPIY:SOURce on page 85

[ :SOURce<hw> ] :BB:C2K:COPIY:DESTInation on page 85

[ :SOURce<hw> ] :BB:C2K:COPIY:COFFset on page 84

[ :SOURce<hw> ] :BB:C2K:COPIY:EXECute on page 85

**Predefined Settings**

Accesses the dialog for setting predefined configurations in "Downlink / Forward" direction, see [Chapter 3.6.2, "Predefined Settings - Downlink"](#), on page 38.

**Additional Mobile Station**

Accesses the dialog for simulating up to 64 additional mobile stations, see [Chapter 3.6.3, "Additional Mobile Station - Uplink"](#), on page 41.

**Adjust Total Power to 0dB**

Sets the power of an enabled channel so that the total power of all the active channels is 0 dB. This does not change the power ratio among the individual channels.

This parameter is available when the "CDMA2000 > State > On".

Remote command:

[ :SOURce<hw> ] :BB:C2K:POWer:ADJust on page 87

**Total Power**

Displays the total power of the active channels.

The total power is calculated from the power ratio of the powered up code channels with modulation on. If the value is not equal to 0 dB, the individual code channels are internally adapted so that the "Total Power" for achieving the set output level is 0 dB. Power ratios between the channels are retained.

Remote command:

[ :SOURce<hw> ] :BB:C2K:POWer [ :TOTal ] ? on page 87

**Select ...**

Selects the base or mobile station and opens a dialog for editing the selected base or mobile station.

The dialogs are described in [Chapter 3.6.4, "Base Station Configuration"](#), on page 43 and [Chapter 3.6.7, "Mobile Station Configuration \(MS\)"](#), on page 70.

Remote command:

(the base station or mobile station is selected by the keyword index `BSTation<i>` or `MSTation<i>`.)

**Base Station/Mobile Station State**

Activates a base or mobile station.

Remote command:

[ :SOURCE<hw> ] :BB:C2K:BSTation<st>:STATE on page 135

[ :SOURCE<hw> ] :BB:C2K:MSTation<st>:STATE on page 146

**3.6.2 Predefined Settings - Downlink**

1. To access this dialog, select "CDMA 2000 > General > Link Direction > Downlink / Forward".
2. Select "Basestations > Predefined Settings".

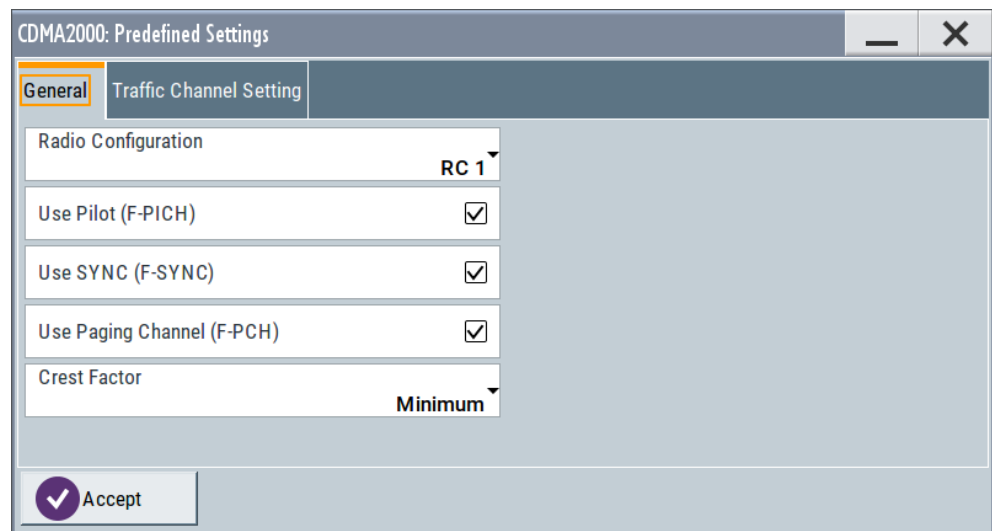

This dialog contains the predefined settings.

The channel table of base station 1 is filled (preset) with the set parameters.

With the "Predefined Settings" function, it is possible to create highly complex scenarios with just a few keystrokes. This function is of use if, say, just the envelope of the signal is of interest.

A separate set of settings of all predefined parameters is provided for each radio configuration. If the radio configuration is changed, the set of traffic channel settings belonging to this RC is automatically indicated.

In the "Traffic Channel Settings" section, the number and the structure of the traffic channels used in the test scenario is set. The selected structure is valid for all activated traffic channels.

The indicated parameters depend on the radio configuration. Their settings are specific for the selected radio configuration.

Also, the desired range for the crest factor is selected. Button "Accept" presets the channel table of base station 1 with the predefined parameters.

**Radio Configuration**

Selects the radio configuration (RC).

The R&S SMW provides a separate set of settings of all predefined traffic channel parameters for each radio configuration. If the radio configuration is changed, the set of traffic channel table values belonging to this RC is automatically activated.

Remote command:

`[ :SOURCE<hw> ] :BB:C2K:PPARAmeter:RCONfiguration` on page 104

**Use Pilot (F-PICH)**

Selects if pilot channel F-PICH is used in the scenario or not.

Remote command:

`[ :SOURCE<hw> ] :BB:C2K:PPARAmeter:PICHannel [ :STATe ]` on page 104

**Use Sync (F-Sync)**

Selects if sync channel F-SYNC is used in the scenario or not.

Remote command:

`[ :SOURCE<hw> ] :BB:C2K:PPARAmeter:SCHannel [ :STATe ]` on page 104

**Use Paging Channel (F-PCH)**

Selects if paging channel F-PCH is used in the scenario or not.

Remote command:

`[ :SOURCE<hw> ] :BB:C2K:PPARAmeter:PCChannel [ :STATe ]` on page 103

**Crest Factor**

Selects the desired range for the crest factor of the test scenario. The crest factor of the signal is kept in the desired range by automatically setting appropriate Walsh Code Numbers.

"Minimum"	The crest factor is minimized by assigning Walsh codes which are chosen as close as possible.
"Average"	An average crest factor is set. The Walsh codes are distributed uniformly over the code domain.
"Worst"	The crest factor is set to an unfavorable value (i.e. maximum) by assigning Walsh codes which are separated as widely as possible.

Remote command:

`[ :SOURCE<hw> ] :BB:C2K:PPARAmeter:CRESt` on page 102

**Traffic Channel Setting**

Access:

"CDMA 2000 > General > Link Direction > Downlink / Forward > Basestations > Predefined Settings > Traffic Channel Setting"

CDMA2000: Predefined Settings	
<div style="display: flex; justify-content: space-between;"> <span>General</span> <span>Traffic Channel Setting</span> </div>	
Number Of Traffic Channels	1
Number Of Supplemental (F-SCH)	1
Use Fundamental (F-FCH)	<input checked="" type="checkbox"/>
Frame Length / ms	20.0
Data Rate / kbps	1.2
<input checked="" type="button" value="Accept"/>	

#### Number of Traffic Channels ← Traffic Channel Setting

Sets the number of activated traffic channels. Channels F-DCCH, F-FCH, and F-SCH form a traffic channel.

Remote command:

`[ :SOURce<hw> ] :BB:C2K:PPARameter:TCHannel:COUNT` on page 104

#### Use Dedicated Control (F-DCCH) ← Traffic Channel Setting

Selects if the dedicated control channel F-DCCH is activated for the traffic channel or not. PN9 is used as a data source for F-DCCH.

The set state is specific for the selected radio configuration.

F-DCCH cannot be activated for radio configuration RC1 and RC2.

Remote command:

`[ :SOURce<hw> ] :BB:C2K:PPARameter:TCHannel:DCCHannel [ :STATe ]`  
on page 105

#### Use Fundamental (F-FCH) ← Traffic Channel Setting

Selects if the fundamental channel F-FCH is activated for the traffic channel or not. PN9 is used as data source for F-FCH. The set value is specific for the selected radio configuration.

Remote command:

`[ :SOURce<hw> ] :BB:C2K:PPARameter:TCHannel:FCHannel [ :STATe ]`  
on page 106

#### Number of Supplemental (F-SCH) ← Traffic Channel Setting

Sets the number of activated supplemental channels F-SCH. PN9 is used as data source for F-SCH. The set value is specific for the selected radio configuration.

The maximum number depends on the selected radio configuration:

- RC1 and RC2: 0 ... 7
- RC3, RC4, and RC5: 0 ... 2

Remote command:

`[ :SOURce<hw> ] :BB:C2K:PPARameter:TCHannel:SCHannel:COUNT`

on page 106

#### **Frame Length ← Traffic Channel Setting**

Sets the frame length of the traffic channel. The set value is specific for the selected radio configuration.

The value range for the frame length depends on the selected radio configuration:

- RC1 and RC2: 20 ms
- RC3 to RC5: 5, 20, 40 ms and 80 ms

Remote command:

`[ :SOURce<hw> ] :BB:C2K:PPARameter:TCHannel:FLENgth` on page 106

#### **Data Rate ← Traffic Channel Setting**

Sets the data rate for F-FCH and all F-SCH. The set value is specific for the selected radio configuration.

The value range depends on the set frame length.

Remote command:

`[ :SOURce<hw> ] :BB:C2K:PPARameter:TCHannel:DATA:RATE` on page 105

#### **Accept**

Presets the channel table of base station 1 with the parameters defined in the "Predefined Settings" dialog. Base station one is switched on, the other base stations are switched off.

Remote command:

`[ :SOURce<hw> ] :BB:C2K:PPARameter:EXECute` on page 103

### **3.6.3 Additional Mobile Station - Uplink**

1. To access the additional mobile station settings, select "CDMA 2000 > General > Link Direction > Uplink / Reverse".

2. Select "Mobile Stations > Additional Mobile Station".

CDMA2000: Add MS (Based On MS4)	
State	0
Number Of Additional MS	4
LC Mask Step	00 0001
Power Offset	0.00 dB
Time Delay Step	0 Chips

The dialog provides the settings for configuring additional mobile stations.

It is possible to simulate up to 64 additional mobile stations and thus to generate a signal that corresponds to the received signal for a base station with high capacity utilization.

The fourth mobile station (MS4) serves as a template for all other stations. The following parameters are the only ones modified for the additional mobile stations:

- LC Mask Step (different for all stations)
- Power (different to MS4, but identical among themselves)

#### State

Activates additional mobile stations. At "State Off", all the additional mobile stations are switched off.

Remote command:

`[ :SOURCE<hw> ] :BB:C2K:MSTation:ADDITIONAL:STATE` on page 139

#### Number of Additional MS

Sets the number of additional mobile stations. As many as 64 additional mobile stations can be simulated.

Remote command:

`[ :SOURCE<hw> ] :BB:C2K:MSTation:ADDITIONAL:COUNT` on page 138

#### LC Mask Step

Enters the step width for increasing the LC mask of the additional mobile stations. The start value is the scrambling code of MS4.

The Long Code generator mask serves for channel-specific and user-specific scrambling of the code channel.

Remote command:

`[ :SOURCE<hw> ] :BB:C2K:MSTation:ADDITIONAL:LCMask:STEP` on page 138

#### **Power Offset**

Sets the power offset of the active channels of the additional mobile stations to the power outputs of the active channels of MS4.

The resultant power must fall within the range 0 ... - 80 dB. If the value is above or below this range, it is limited automatically.

Remote command:

`[ :SOURCE<hw> ] :BB:C2K:MSTation:ADDITIONAL:POWER:OFFSET` on page 138

#### **Time Delay Step**

Enters the step width for the time delay of the additional mobile stations to one another. The start value returns the time delay of MS4. Entry is made in chips and can be a maximum of one frame.

The time delay allows mobile stations to be simulated even if the arrival of their signals is not synchronized at the base station.

Remote command:

`[ :SOURCE<hw> ] :BB:C2K:MSTation:ADDITIONAL:TDElay:STEP` on page 139

### **3.6.4 Base Station Configuration**

1. To access this dialog, select "CDMA 2000 > General > Transmission Direction > Downlink / Forward".
2. Select "Basestations > Basestation > BS1...BS4".

Base stations can be configured independently of one another.

#### **3.6.4.1 Common Settings**

1. To access this dialog select "Basestations > Basestation > BS1...BS4".
2. Select "BS1...BS4 > Common".

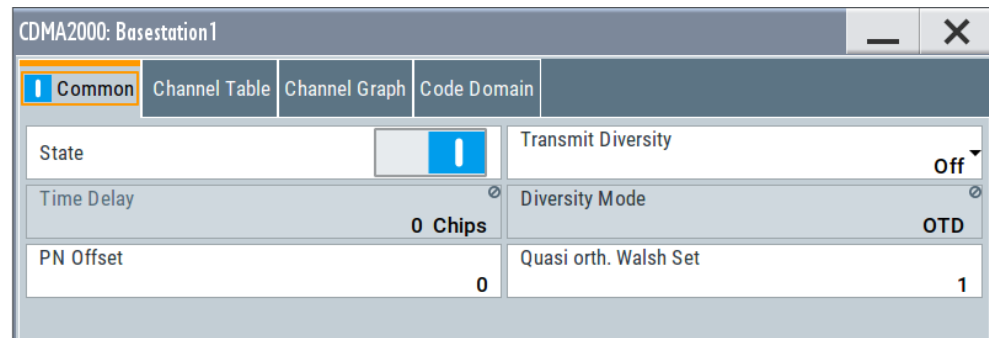

This dialog comprises the common settings required for configuring the basestation.

### State

Activates or deactivates the selected base station.

Remote command:

[\[:SOURCE<hw>\]:BB:C2K:BSTation<st>:STATE](#) on page 135

### Transmit Diversity

Switches transmit diversity on and off.

The signal can be sent simultaneously on several antennas. Various forms of transmit diversity are described in the CDMA2000 standard. Different coding is used to divide the signal between the two antennas. As a result, the receiver can decode the traffic signal from the two input signals and is less liable to fading and other interference. The R&S SMW can simulate the signal of one of the two antennas.

To activate transmit diversity, the antennas whose signals are to be simulated must be specified. The signal is generated differently depending on the selected antenna.

Additionally two diversity schemes for the calculation of the signals are available for selection at "Diversity Mode".

"Off" No transmit diversity

"Antenna 1" Calculates and applies the output signal for antenna 1. The diversity scheme is selected at "Diversity Mode".

"Antenna 2" Calculates and applies the output signal for antenna 2. The diversity scheme is selected at "Diversity Mode".

Remote command:

[\[:SOURCE<hw>\]:BB:C2K:BSTation<st>:TDIVersity](#) on page 136

### Time Delay

Enters the time delay of the signal of the selected basestation compared to the signal of BS1.

**Note:** For BS1, this value is always 0 and read-only.

Remote command:

[\[:SOURCE<hw>\]:BB:C2K:BSTation<st>:TDELay](#) on page 135

### Diversity Mode

Selects the diversity scheme for "Transmit Diversity".

The diversity scheme defines the calculation mode of the signal for the selected antenna (at Transmit Diversity).

"OTD"	Orthogonal Transmit Diversity Mode. A forward link transmission method which distributes forward link channel symbols among multiple antennas and spreads the symbols with a unique Walsh or quasi-orthogonal function associated with each antenna.
"STS"	Space Time Spreading Mode. A forward link transmission method which transmits all forward link channel symbols on multiple antennas and spreads the symbols with complementary Walsh or quasi-orthogonal functions.

Remote command:

`[ :SOURCE<hw> ] :BB:C2K:BSTation<st>:TDIVersity:MODE` on page 136

#### PN Offset

Enters the PN offset (short code).

The PN offset determines the start phase of these PN short-code sequences (see [Chapter 2.1.8, "PN Short-Code Scrambling - Downlink"](#), on page 16).

This permits signals of different basestations to be distinguished.

Remote command:

`[ :SOURCE<hw> ] :BB:C2K:BSTation<st>:PNOffset` on page 135

#### Quasi orth Walsh Set

Selects the Quasi Orthogonal Walsh Set. The standard defines three different sets.

The so-called 'quasi-orthogonal Walsh sets' can be used in addition to the Walsh codes. They increase the number of possible channels and thus extend the basestation capacity. When the quasi-orthogonal Walsh code is used, spreading the data stream results in complex spreading also through an additional rotation of the output phase (the spreading code then consists of a real and an imaginary part).

In the channel table, a decision can be made for each channel whether the Walsh code of the standard set or of the quasi-orthogonal set should be used. The quasi-orthogonal Walsh codes are used if "On" is activated in column "Q. Orth".

Remote command:

`[ :SOURCE<hw> ] :BB:C2K:BSTation<st>:QWSet` on page 135

#### 3.6.4.2 Channel Table - BS

1. To access this dialog select "Base Stations > Base Station > BS1...BS4".
2. Select "BS1...BS4 > Channel Table".

	Channel Type	Real Time	RC	Frame Length /ms	Data Rate /kbps	Walsh	Q. Orth.	Power /dB	Data	Dlist Pattern	More Params	State	Dom Conf
0-1	F-PICH			20.0	NotUsd	0/64		-7.00	All 0		Config..	On	
0-2	F-TDPICH			20.0	NotUsd	16/128		0.00	All 0		Config..	Off	
0-3	F-APICH			20.0	NotUsd	0/64		0.00	All 0		Config..	Off	
0-4	F-ATDPICH			20.0	NotUsd	0/64		0.00	All 0		Config..	Off	
0-5	F-SYNC	Off		26.6	1.2	32/64		-12.72	PN 9		Config..	On	
0-6	F-PCH			20.0	9.6	1/64		-6.72	PN 9		Config..	On	

In this tab, you can set the channel parameters individually.

Up to 78 channels are available for each base station. Channels 0 to 1 to 0 to 11 are assigned to the special channels which are responsible for the correct communication between base station and mobile station. The packet channels (0-12 to 0-14) and the traffic channels (1-0 and above) transmit the data.

A traffic channel is used for transmitting the radio link information, i.e. for communication with the addressee. The traffic channels consist of a dedicated channel, a fundamental channel and, depending on the radio configuration, of up to seven supplemental channels.

The packet data channel and the packet data control channels are used for transmitting data packets usually at higher data rates than is the case with purely circuit-mode traffic channels. The radio configuration of these channels is defined as 10 in accordance with the CDMA2000 standard.

The number of sub channels and the sub channel types of a traffic channel depend on the selected radio configuration. The radio configuration can be set separately for each traffic channel and is the same for all sub channels of this traffic channel. It determines among other things the channel coding types, the frame lengths and the data rates that can be used and the settings of fixed parameter, e.g. CRC length. The R&S SMW provides a separate set of settings of all channel table parameters for each radio configuration. Thus, when the radio configuration is changed, the current set of settings is internally stored for the old radio configuration. The complete set of settings belonging to the new radio configuration is activated and indicated in the channel table.

### Channel Number

Displays the channel numbers.

The channel number is made up of two numbers. If the first number is 0 it identifies the special channels, i.e. the control channels and packet channels. A first number of 1 to 8 designates the traffic channels. The second number refers consecutively to the special channels or the subchannels of a traffic channel.

All available channels are always displayed, even the channels that are inactive. The number of subchannels per traffic channel 1 (four or eight) depends on the chosen radio configuration.

Each channel is switched on and off by the "On/Off" button in the "State" column.

Remote command:

In remote control, the channel is selected via the suffix to the keywords :CGRoup<n>:COFFset<n>.

CGRoup0 selects the special channels group, CGRoup1 to 8 the traffic channel.

COFFset1 to 14 selects either the special channel or the code channel of a traffic channel. E

For example, :CGRoup0:COFFset14 selects the packet channel F-PDCH, :CGRoup3:COFFset1 selects the F-FCH of traffic channel 3.

### Channel Type

Indication of the channel type (see following table).

**Table 3-1: List of supported channel types and their sequence in the CDMA2000 channel table**

Index	Short form	Name	Function
0-1	F-PICH	Forward Pilot Channel	The base station continuously transmits the pilot channel. This channel provides capabilities for soft <b>handoff</b> and coherent detection. Handoff is a procedure where a mobile with an on-going call changes channel and/or base station under the supervision of the network. The Walsh code is 0.
0-2	F-TDPICH	Forward Transmit Diversity Pilot Channel	The base station continuously transmits this pilot channel from the secondary antenna when transmit diversity is enabled.
0-3	F-APICH	Forward Auxiliary Pilot Channel	This pilot channel transmits the base station as an option.
0-4	F-ATDPICH	Forward Auxiliary Transmit Diversity Pilot Channel	The base station optionally transmits this pilot channel from the secondary antenna when transmit diversity is enabled.
0-5	F-SYNC	Forward Synchronization Channel	The synchronization channel enables the mobile station to synchronize with the base station. It contains the PN offset, the system time and the long code status, information about the paging channel, together with the system ID and the network ID. The Walsh code is 32.
0-6	F-PCH	Forward Paging Channel	The paging channel carries control information specific to a mobile station when the network does not know where the mobile station is located.
0-7	F-BCCH	Forward Broadcast Channel	The broadcast channel is used to broadcast system- and cell-specific information.
0-8	F-QPCH	Forward Quick Paging Channel	The paging channel contains short form information for the mobile station, particularly if the latter is not transmitting.

Index	Short form	Name	Function
0-9	F-CPCCH	Forward Common Power Control Channel	
0-10	F-CACH	Forward Common Assignment Channel	
0-11	F-CCCH	Forward Common Control Channel	General channel for transmitting control information. It also provides a mean for paging functions but it supports different data rates. It provides capability for short burst data communications.
0-12/13	F-PDCCH	Forward Packet Data Control Channel	The F-PDCCH carries the control information for the F-PDCH.
0-14	F-PDCH	Forward Packet Data Channel	Packet-oriented data channel, supports high data rates
1-1	F-FCH	Forward Fundamental Channel	Subchannel of a traffic channel. Contains control data and user data.
1-2	F-SCCH1	Forward Supplemental Code Channel	Subchannel of a traffic channel. Enables higher data rates for control and user data.
1-2	F-SCH1	Forward Supplemental Channel	Subchannel of a traffic channel. Enables higher data rates for control and user data.
...			
1-4	F-DCCH	Forward Dedicated Control Channel (RC3, RC4 and RC5)	Subchannel of a traffic channel. It transports specific control information.

Remote command:

`[ :SOURCE<hw> ] :BB:C2K:BSTation<st>:CGROUP<di0>:COFFset<ch>:TYPE?`  
on page 124

### Radio Configuration (RC)

Selects radio configuration of the traffic channel.

The radio configuration determines the channel types, the frame lengths, the channel coding types and the data rates that can be used.

The radio configuration is the same for all sub channels of a traffic channel. If the radio configuration is modified for one of the sub channels, the new value is then automatically used by all other subchannels of this traffic channel.

The radio configuration for the packet channels F-PDCCH and F-PDCH is fixed to RC10.

The R&S SMW provides a separate set of settings of all channel table parameters for each radio configuration. Changing the radio configuration causes the settings belonging to the new RC value to be activated in the channel table (the settings belonging to the old RC value are stored).

The radio configuration determines the permissible frame lengths. The frame length defines the permitted data rate and channel coding type which in turn determine the permitted Walsh codes.

This relation causes a hierarchy within the following parameters:

"Frame Length" -> "Data Rate + Channel Coding Type" -> "Walsh Code"

Changing one of the parameters in this hierarchy automatically causes the lower-level settings to be changed if they are no longer permitted following the change to the higher-level parameter.

Remote command:

`[ :SOURce<hw> ] :BB:C2K:BSTation<st>:CGRoup<di0>:RCONfiguration`  
on page 126

### Frame Length

Enters the frame length of the channel. The set value is specific for the selected radio configuration.

The value range depends on the channel type and radio configuration. The frame length of the F-SCH is fixed to 26.6.ms. The maximum frame length is 160 ms, the minimum frame length is 5 ms.

The frame length affects the data rates and the channel coding types that are possible within a channel. Changing the frame length can lead to a change of data rate and/or the channel coding type, which in turn can bring about a change of the Walsh code.

Remote command:

`[ :SOURce<hw> ] :BB:C2K:BSTation<st>:CGRoup<di0>:COFFset<ch>:`  
`FLENgth` on page 118

### Data Rate

Enters the data rate of the channel. The set value is specific for the selected radio configuration.

The R&S SMW supports all data rates between 1.2 kbps and 1,036.8 kbps defined in the standard.

The value range depends on the frame length. If the frame length is changed so that the set data rate becomes invalid, the next permissible value is automatically set.

The data rate affects the Walsh code (spreading factor) that is possible within a channel. If a data rate is changed so that the selected Walsh code becomes invalid, the next permissible value is automatically set.

Remote command:

`[ :SOURce<hw> ] :BB:C2K:BSTation<st>:CGRoup<di0>:COFFset<ch>:DATA:`  
`RATE` on page 118

### Walsh

Assigns the Walsh code to the channel (see [Chapter 2.1.7, "Variable-Length Walsh Spreading - Downlink"](#), on page 16, and see ["Code domain "](#) on page 54). The set value is specific for the selected radio configuration.

The code channel is spread with the set Walsh code (spreading code).

The value range of the Walsh code depends on the frame length, the channel coding type and the data rate.

If one of these parameters is changed so that the set Walsh code gets invalid, the next permissible value is automatically set.

The standard assigns a fixed Walsh code to some channels (F-PICH, for example, always uses Walsh code 0). Generally, the Walsh code can only be varied within the range specified by the standard.

Remote command:

```
[ :SOURCE<hw> ] :BB:C2K:BSTation<st>:CGROUP<di0>:COFFset<ch>:WCODE
```

on page 125

### Quasi Orthogonal Walsh Code State

Activates/deactivates the use of the quasi-orthogonal Walsh codes for the channel. The set state is specific for the selected radio configuration.

Depending on the channel type and other parameters, the standard does not allow the use of quasi-orthogonal codes. In this case, the selection field is dimmed.

The quasi-orthogonal Walsh code set is selected for all channels of the base station in the upper area of the CDMA200 dialog.

Remote command:

```
[ :SOURCE<hw> ] :BB:C2K:BSTation<st>:CGROUP<di0>:COFFset<ch>:QWCode:STATE
```

on page 120

### Power

Sets the channel power in dB. The set value is specific for the selected radio configuration.

The power entered is relative to the powers outputs of the other channels. If "Adjust Total Power to 0 dB" is executed (top level of the CDMA dialog), all the power data is relative to 0 dB.

The set "Power" value is also the start power of the channel, if "For Output Power Control > (Mis-)Use" is activated.

**Note:** The maximum channel power of 0 dB applies to non-blanked channels (duty cycle 100%).

With blanked channels, the maximum value can be increased to values greater than 0 dB. Where the maximum value is calculated as:

$$10 * \log_{10} 1 / \text{duty\_cycle}$$

Remote command:

```
[ :SOURCE<hw> ] :BB:C2K:BSTation<st>:CGROUP<di0>:COFFset<ch>:POWER
```

on page 119

### Data

Selects data source. The set value is specific for the selected radio configuration.

The following standard data sources are available:

- "All 0, All 1"  
An internally generated sequence containing 0 data or 1 data.
- "PNxx"  
An internally generated pseudo-random noise sequence.
- "Pattern"  
An internally generated sequence according to a bit pattern.  
Use the "Pattern" box to define the bit pattern.
- "Data List/Select DList"  
A binary data from a data list, internally or externally generated.

Select "Select DList" to access the standard "Select List" dialog.

- Select the "Select Data List > navigate to the list file \*.dm\_iqd > Select" to select an existing data list.
- Use the "New" and "Edit" functions to create internally new data list or to edit an existing one.
- Use the standard "File Manager" function to transfer external data lists to the instrument.

See also:

- Section "Modulation Data" in the R&S SMW user manual.
- Section "File and Data Management" in the R&S SMW user manual.
- Section "Data List Editor" in the R&S SMW user manual

Remote command:

`[ :SOURce<hw> ] :BB:C2K:BSTation<st>:CGROUP<di0>:COFFset<ch>:DATA`  
on page 116

`[ :SOURce<hw> ] :BB:C2K:BSTation<st>:CGROUP<di0>:COFFset<ch>:DATA:`  
`PATtern` on page 117

`[ :SOURce<hw> ] :BB:C2K:BSTation<st>:CGROUP<di0>:COFFset<ch>:DATA:`  
`DSElect` on page 117

### More Params

Provides access to a dialog covering additional parameters of the selected channel (see [Chapter 3.6.5, "More Parameters - BS Channel Table"](#), on page 56 ).

Remote command:

n.a.

### Channel State

Activates or deactivates the channel. The set state is specific for the selected radio configuration.

Remote command:

`[ :SOURce<hw> ] :BB:C2K:BSTation<st>:CGROUP<di0>:COFFset<ch>:STATe`  
on page 120

### Domain Conflict

Displays whether the channel has a code domain conflict with another channel. If there is a conflict, an attention triangle appears and the column is colored soft orange. If there is no conflict, the column is colored soft gray. The indicated value is specific for the selected radio configuration.

To access the graphical display of code domain occupancy by all the active code channels, see the "Code Domain" dialog (also see ["Code domain "](#) on page 54).

Remote command:

`[ :SOURce<hw> ] :BB:C2K:BSTation<st>:DCONflict [ :STATe ] ?` on page 127

`[ :SOURce<hw> ] :BB:C2K:BSTation<st>:DCONflict:RESolve` on page 127

#### 3.6.4.3 Code Domain and Channel Graphs

The Walsh codes of variable length used by CDMA2000 are the so-called Hadamard codes.

The structure of these codes is explained below. The code matrix of the order N+1 is obtained from the matrix N by extending the latter to the right and downwards through copying and downwards to the right by copying and inversion.

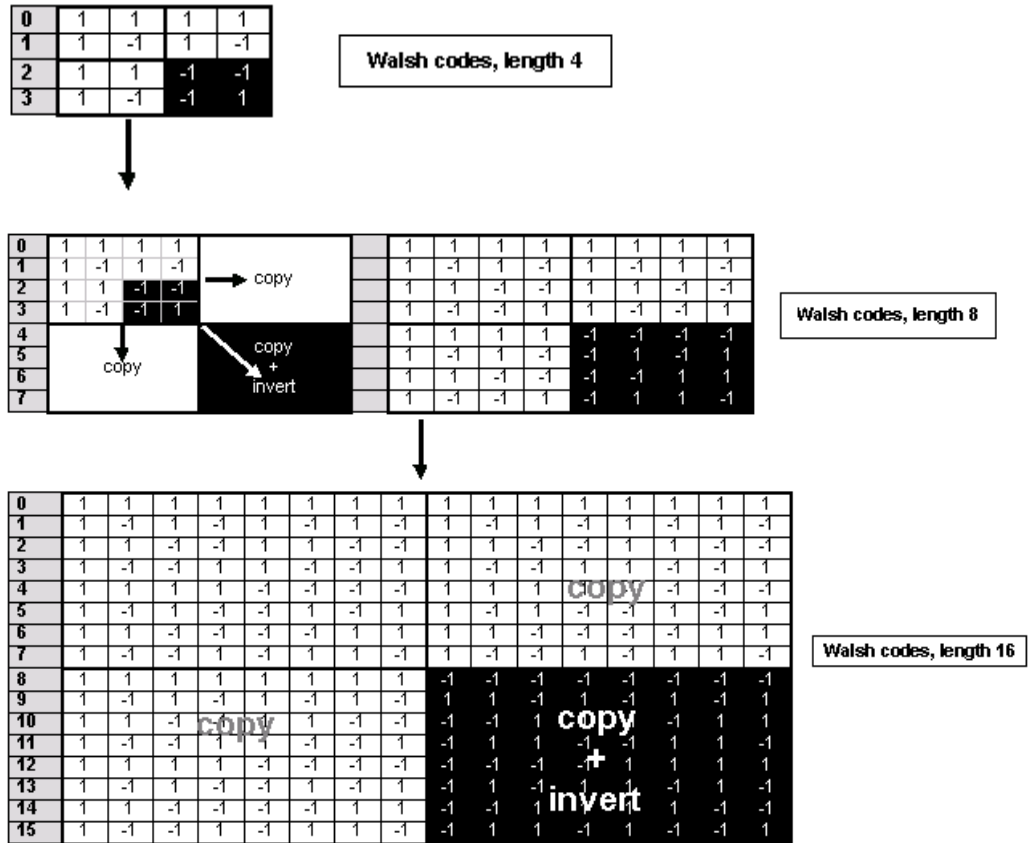

Figure 3-1: Generation scheme of Walsh code

Walsh codes of the lengths 4, 8, 16, 32, 64, and 128 are used in CDMA2000 with spreading rate 1. The greater the spreading factor / Walsh code length, the smaller the useful symbol rate prior to spreading and vice versa.

In contrast to the spreading codes of 3GPP, Walsh codes of short lengths (low spreading factor) do not occupy a block area in a Walsh matrix of larger spreading factor. Several lines (ratio of the two spreading factors) are occupied in the matrix with a higher spreading factor, distributed over the whole matrix. This behavior is illustrated in the diagram below. This results from the structuring scheme of the Walsh codes that are obtained by copying and inverting the next smaller matrix.

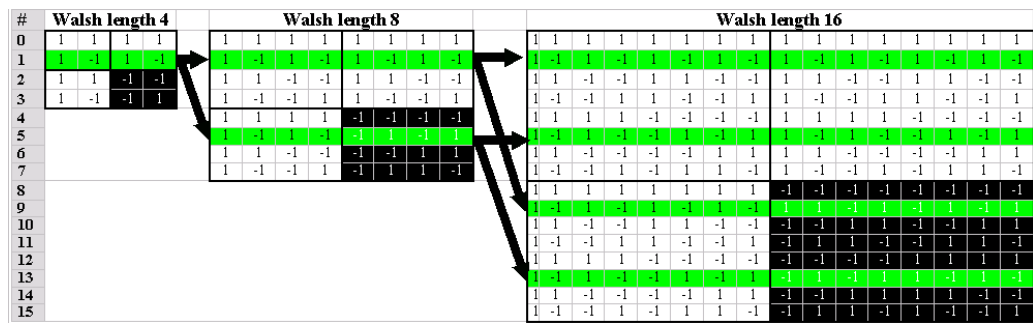

Figure 3-2: Walsh code tree

If a Walsh code with the length 4 and index 1 is used, codes 1 and 5 are disabled at the length 8, and codes 1, 5, 9 and 13 at the length 16 because codes of greater length contain the output code of shorter length (or its inversion).

When using such conflicting Walsh codes simultaneously, the signals of the associated code channels are mixed so that they can no longer be separated in the receiver. Orthogonality then is lost.

The matrix range with the highest spreading factor (i.e. 128), which is based on the spreading code selected in the code tree, is then defined as domain of a specific Walsh spreading code. Using a spreading code means that its entire domain is used.

**Channel graph**

1. To access the channel graph, select "Basestations > Basestation > BS1...BS4".
2. Select "BS1...BS4 > Channel Graph".

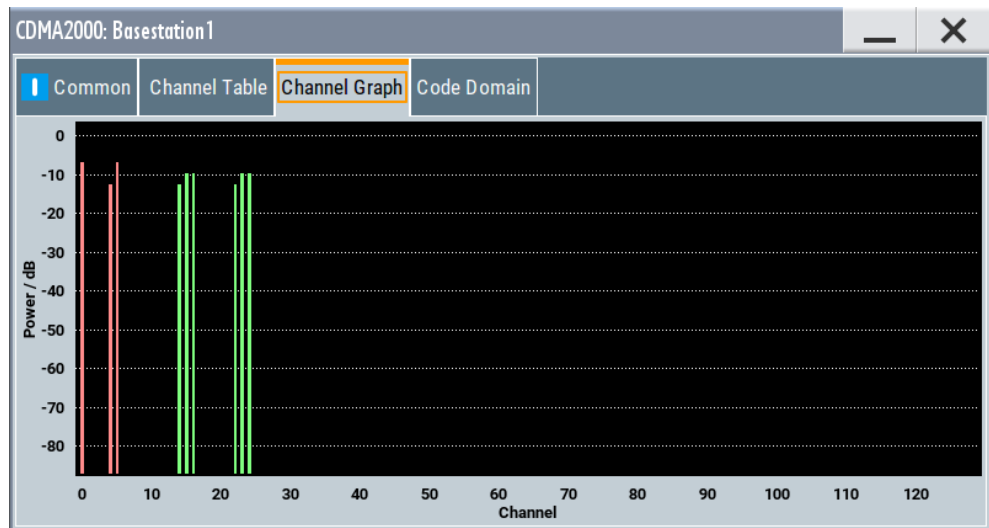

This tab graphically shows the active code channels. The channel number is plotted on the X axis. The red bars represent the special channels, the green bars the traffic channels. The channel index is plotted on the X-axes. The height of the bars shows the relative power of the channel.

### Code domain

1. To access this dialog select "Basestations > Basestation > BS1...BS4".
2. Select "BS1...BS4 > Code Domain".

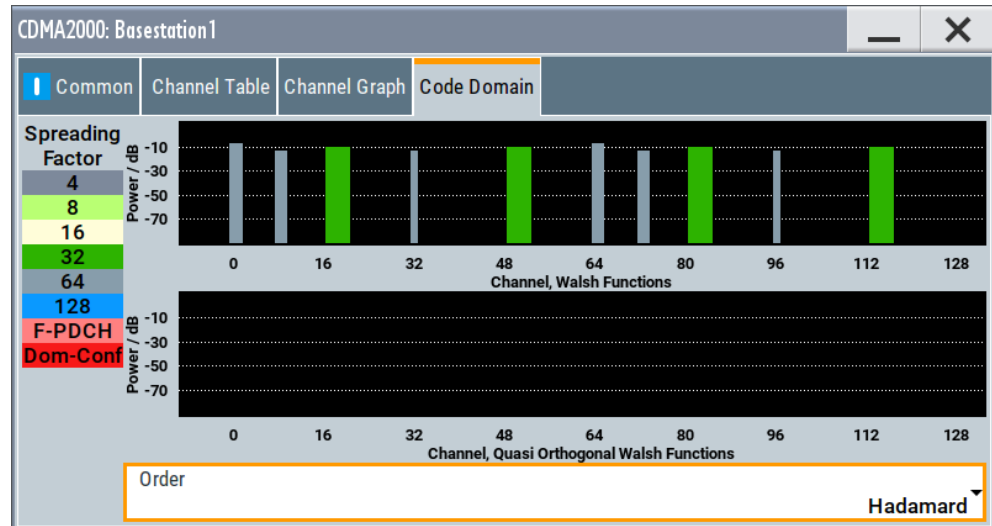

This tab shows the code domain of the standard Walsh set and the quasi-orthogonal Walsh sets graphically.

The "Code Domain" graphic shows the assignment of active code channels in the code domain.

The code numbers are plotted on the X axes, the colored bars show the code channels. The legend at the left of the graph indicates the assignment of colors to the spreading factors. An additional color is reserved for the packet channel F-PDCH because this channel can be assigned to more than one code channel. The height of the bars indicates the power of the code channel.

In this display assignment of the domains can be seen at a glance. Compared to 3GPP it is however much more difficult to see whether the code domains of different channels overlap, i.e. whether there is a domain conflict. This is due to the structure of the Walsh codes described above. The reason is that no block areas are occupied in the domain but several areas of minimum width are distributed over the whole domain.

Therefore, the occurrence of a domain conflict is indicated by a red dot marking of the involved channels. In addition, in the channel table, a code domain conflict is indicated in the column "Dom Conf" on the far right of the graph by an orange-colored column.

CDMA2000: Basestation 1													
Common		! Channel Table		Channel Graph			Code Domain						
	Channel Type	Real Time	RC	Frame Length /ms	Data Rate /kbps	Walsh	Q. Orth.	Power /dB	Data	Dlist Pattern	More Params	State	Dom Conf
0-1	F-PICH			20.0	NotUsd	0/64		-7.00	All 0		Config..	On	!
0-2	F-TDPICH			20.0	NotUsd	16/128		0.00	All 0		Config..	On	
0-3	F-APICH			20.0	NotUsd	0/64		0.00	All 0		Config..	On	!
0-4	F-ATDPICH			20.0	NotUsd	0/64		0.00	All 0		Config..	On	!
0-5	F-SYNC	Off		26.6	1.2	32/64		-12.72	PN 9		Config..	Off	
0-6	F-PCH			20.0	9.6	1/64		-6.72	PN 9		Config..	Off	



The graph is calculated from the settings that have been made. A change in the settings results at once in a change of the graphical display.

#### Order - Code Domain BS

Switches the order of the spreading codes.

"Hadamard" The code channels are displayed in the order determined by the Hadamard matrix. The codes are numbered as Walsh codes according to the standard.

"Bit reversed" The code channels are displayed in the order defined by the Orthogonal Variable Spreading Factor (OVSF) code tree (3GPP code). The Walsh codes and their generation scheme are closely related to the spreading codes of 3GPP. Basically, the same spreading sequences are used, only the order in the respective code trees is different. According to 3GPP TS 25.213, the following code tree is used:

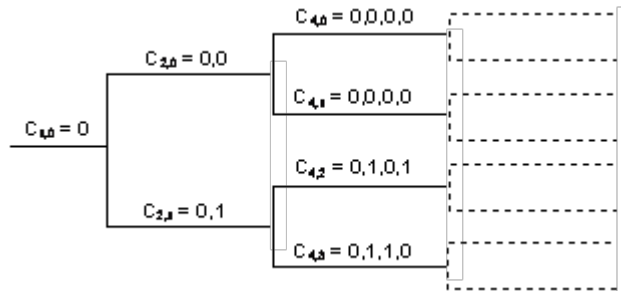

To find a 3GPP code that corresponds to a CDMA2000 code, the bit-inverted line (line index) has to be selected in the 3GPP matrix of identical spreading factor.

#### Example:

The 3GPP spreading code matching line 10 of the 16-bit Walsh code matrix is searched for. The binary form of the line index 10 (with 4 bits, because of Walsh length  $16 = 2^4$ ) is 1010. The bit-inverted index is 0101, i.e. 5 in decimal notation. This means that the Walsh code No. 10 with the length 16 corresponds to the 3GPP spreading code 5 of the same length (spreading factor).

Remote command:

`[ :SOURCE<hw> ] :BB:C2K:BSStation<st>:DCONflict:MODE` on page 126

### 3.6.5 More Parameters - BS Channel Table

1. To access this dialog, select "CDMA 2000 > General > Link Direction > Downlink / Forward".
2. Select "Base Stations > Select Base Station > BS1...BS4".
3. Select "Channel Table > Channel# > More Params > Config"

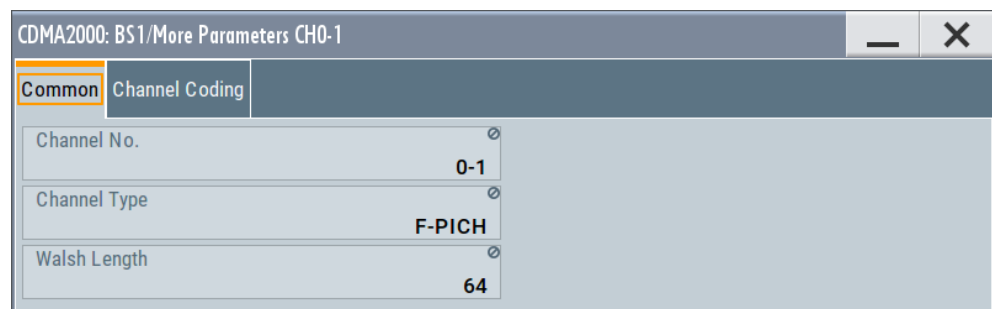

This dialog contains the parameters required for configuring the channel coding.

The settings for the packet channel F-PDCH channel and all other channels are different (see [Chapter 3.6.6, "More Parameters for F-PDCH - BS"](#), on page 65). The dialog for the special channels and the traffic channels is described below.

### 3.6.5.1 General Settings

In the upper section, the channel number, channel type and Walsh length of the selected channel are displayed.

#### Channel No - More Parameters BS

Displays the channel number of the channel.

Remote command:

n.a.

#### Channel Type - More Parameters BS

Displays the type of the channel.

Remote command:

n.a.

#### Walsh Length - More Parameters BS

Displays the Walsh code of the channel. The indicated value is specific for the selected radio configuration.

Remote command:

`[ :SOURCE<hw> ] :BB:C2K:BSTation<st>:CGRoup<di0>:COFFset<ch>:WLENgth?` on page 125

#### LC Mask (hex) - More Parameters BS

Enters the mask of the long-code generator in hexadecimal form. The set value is specific for the selected radio configuration.

The long-code mask is a 42-bit value. The mask serves for channel-specific and user-specific scrambling of the code channel.

The LC Mask is the same for all sub channels of a traffic channel. If the mask is modified for one of the sub channels, the new value is then automatically used by all other subchannels of this traffic channel.

Remote command:

`[ :SOURCE<hw> ] :BB:C2K:BSTation<st>:CGRoup<di0>:COFFset<ch>:LCMask` on page 119

### 3.6.5.2 Power Control

In this section, you can configure the settings for the power control bits. These bits are used to control the transmission power.

1. To access this dialog, select "CDMA 2000 > General > Link Direction > Downlink / Forward".

2. Select "Base Stations > Select Base Station > BS1...BS4".
3. Select "Channel Table > F-FCH/F-DCCH > More Params > Config".

CDMA2000: BS1/More Parameters CH1-1		
Common	Power Control	Channel Coding
Data Source	All 0	
Read Out Mode	Continuous	
For Output Power Control <i>is Not (Mis-)Use</i>	<input type="checkbox"/>	
Power Step	0.00 dB	

This section contains the parameters required for configuring the power control for the channel types F-FCH and F-DCCH.

#### Data Source - Power Control - BS

Defines the data source for the power control bits of the channel. The set value is specific for the selected radio configuration.

The following standard data sources are available:

- "All 0, All 1"  
An internally generated sequence containing 0 data or 1 data.
- "PNxx"  
An internally generated pseudo-random noise sequence.
- "Pattern"  
An internally generated sequence according to a bit pattern.  
Use the "Pattern" box to define the bit pattern.
- "Data List/Select DList"  
A binary data from a data list, internally or externally generated.  
Select "Select DList" to access the standard "Select List" dialog.
  - Select the "Select Data List > navigate to the list file \*.dm\_iqd > Select" to select an existing data list.
  - Use the "New" and "Edit" functions to create internally new data list or to edit an existing one.
  - Use the standard "File Manager" function to transfer external data lists to the instrument.

See also:

- Section "Modulation Data" in the R&S SMW user manual.
- Section "File and Data Management" in the R&S SMW user manual.
- Section "Data List Editor" in the R&S SMW user manual

Remote command:

[ :SOURce<hw> ] :BB:C2K:BSTation<st>:CGROUP<di0>:COFFset<ch>:TPC:  
DATA on page 120

[ :SOURce<hw> ] :BB:C2K:BSTation<st>:CGROUP<di0>:COFFset<ch>:TPC:  
DATA:PATtern on page 122

[ :SOURce<hw> ] :BB:C2K:BSTation<st>:CGROUP<di0>:COFFset<ch>:TPC:  
DATA:DSElect on page 121

### Read Out Mode (Power Control) - BS

Defines power control bits usage. The set value is specific for the selected radio configuration.

With CDMA, the power control bits are used to signal the increase or reduction in transmit power to the called station.

The BS sends power control bits in the traffic channel at an 800 Hz rate instead of the scrambled data bits. The mobile station increases or decrease its output power depending on these power control bits. One to four data bits (depending on the data rate) are replaced a corresponding number of power control bits ("0...0" or "1...1").

With all read out modes, 1 bit is taken from the power control, multiplied and entered into the bitstream. The difference between the modes lies in the usage of the power control bits.

These different modes can be used to set a BS to a specific output power (e.g. with the pattern 11111) and then let it oscillate around this power. This behavior allows power measurements to be carried out at the BS (at quasi-constant power).

Together with the option misuse output power control (see [For Output Power Control - BS](#)), this parameter can also be used to generate various output power profiles.

"Continuous" The power control bits are used cyclically.

"Single + All 0" The power control bits are used once, and then the power control sequence is continued with 0 bits.

"Single + All 1" The power control bits are used once, and then the power control sequence is continued with 1 bit.

"Single + alt. 01"

The power control bits are used once. The power control sequence is continued with 0 bits and 1 bit alternately (in multiples, depending on the data rate, for example, 00001111).

"Single + alt. 10"

The power control bits are used once. The power control bit sequence is continued with 1 bit and 0 bits alternately (in multiples, depending on the data rate, for example, 11110000).

Remote command:

[ :SOURce<hw> ] :BB:C2K:BSTation<st>:CGROUP<di0>:COFFset<ch>:TPC:  
READ on page 124

### For Output Power Control - BS

Activates "(Mis-)Use" of the power control data. The set value is specific for the selected radio configuration.

The power control bits are used to signal the increase or reduction of transmit power to the called station.

If "For Output Power Control > (Mis-)Use" is activated, the specified pattern is used to vary the intrinsic transmit power over time. Every 1.25 ms (800 Hz) a bit of this pattern is removed in order to increase (bit = "1") or reduce (bit = "0") the channel power by the specified "Power Step". The upper limit is 0 dB and the lower limit -80 dB.

The following envelope is produced with the settings:

- Channel power = 0 dB
- Power step = 1.0 dB
- Pattern = "001110100000011"
- "TPC Read Out Mode = Continuous"

**Note:** The first bit is assigned to the first power control section. In this first section, the start power specified in the channel table is always used. Only in the next power control section (with the second power control bit) will the defined power change be effective.

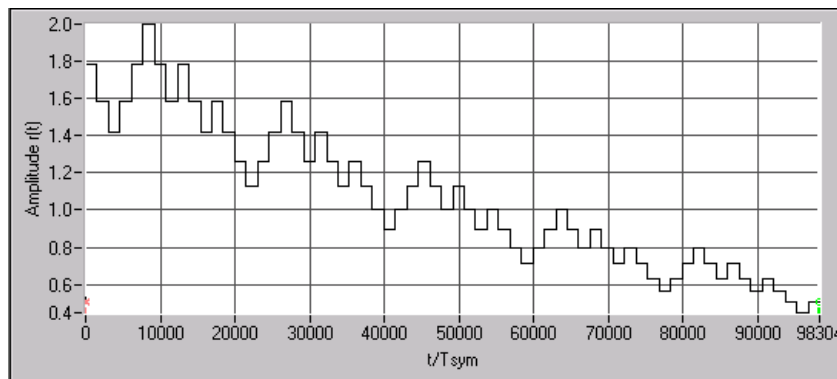

Figure 3-3: Dynamic change of channel power (continuous)

Remote command:

`[ :SOURce<hw> ] :BB:C2K:BSTation<st>:CGRoup<di0>:COFFset<ch>:TPC: MISuse` on page 122

#### Power Step (DPCCH) - BS

Sets the step width of the power change in dB for "(Mis-) use TPC for output power control".

The set value is specific for the selected radio configuration.

Remote command:

`[ :SOURce<hw> ] :BB:C2K:BSTation<st>:CGRoup<di0>:COFFset<ch>:TPC: PSTep` on page 123

### 3.6.5.3 Channel Coding

1. To access this dialog, select "CDMA 2000 > General > Link Direction > Downlink / Forward".
2. Select "Base Stations > Select Base Station > BS1...BS4".

3. Select "Channel Table > Channel# > More Params > Config > Channel Coding"

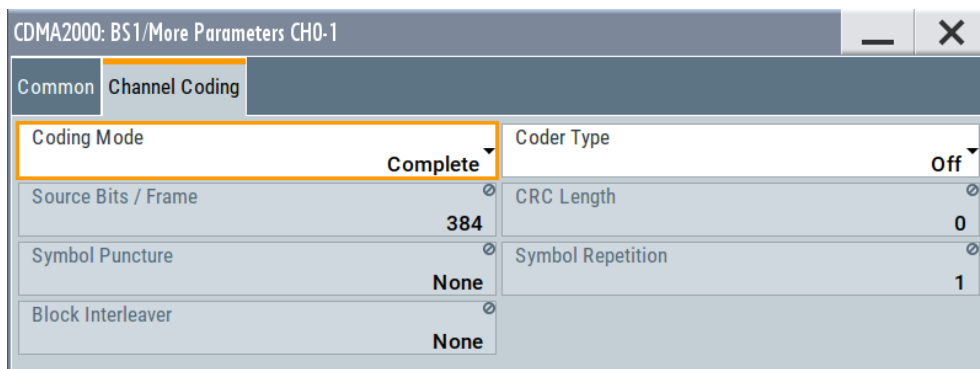

In this section, you can configure the settings for the channel coding. The indicated values and the settings are specific for the selected radio configuration.

In contrast to 3GPP FDD, channel coding with CDMA2000 is part of the physical layer. The channel coding procedure can slightly vary depending on channel type, frame length and data rate.

### Coding Mode

Activates or deactivates channel coding. The set state is specific for the selected radio configuration.

"Off"	Channel coding is deactivated. Channel coding is not performed. The data sources of the individual channels apply their data stream directly to the long-code scrambler. The data source supplies the traffic data with the data rate that would be available at the long-code scrambler after coding is switched on. This effective data rate, which is used for reading off from the data source, is indicated with the parameter "Effective Data Rate". The <code>Data Rate</code> parameter displayed in the channel table continues to affect the "Effective Data Rate", but no longer agrees with it.
"Complete"	The complete channel coding is performed. The channel coding procedure can slightly vary depending on channel type, frame length and data rate.
"Without Inter-leaving"	Except for the block interleaver, the whole channel coding procedure is carried out. In this mode, the frame structure and the convolutional coder of a receiver can be tested.
"Interleaving Only"	In this mode, only a block interleaver is used for coding. This behavior allows the deinterleaver in the receiver to be tested independently of the remaining (de-)coding process.

Remote command:

```
[ :SOURce<hw> ] :BB:C2K:BSTation<st>:CGRoup<di0>:COFFset<ch>:
CCODing:MODE on page 114
```

### Coder Type

Selects error protection. The set value is specific for the selected radio configuration.

Which coder types are available depends on the channel type and other channel settings such as frame length.

If one of these parameters is changed so that the set channel coding type gets invalid, the next permissible value is automatically set.

"Off"	No error protection. This selection is available for the pilot channels only.
"Conv Encoder"	Convolution coder with generator polynomials defined by CDMA. The numeric value defines the rate of the convolution coder.
"Turbo Encoder"	Turbo coder of rate 1/3 in accordance with the CDMA specifications. The numeric value defines the rate of the turbo coder.

Remote command:

```
[ :SOURce<hw> ] :BB:C2K:BSTation<st>:CGROUP<di0>:COFFset<ch>:
CCODing:TYPE on page 115
```

### Source Bits / Frame

Indicates the number of input bits per frame for the channel coder. The indicated value is specific for the selected radio configuration.

Remote command:

```
[ :SOURce<hw> ] :BB:C2K:BSTation<st>:CGROUP<di0>:COFFset<ch>:
CCODing:BITFrame? on page 112
```

### CRC Length

Indicates the CRC (cyclic redundancy code) type (length) for error identification. The indicated value is specific for the selected radio configuration.

Remote command:

n.a.

### Symbol Repetition

Indicates the symbol repetition rate. The value is specific for the selected radio configuration.

Symbol repetition is used together with block symbol puncture for adapting the convolutional or turbo coder output data rate to the required input data rate of the interleaver.

Remote command:

```
[ :SOURce<hw> ] :BB:C2K:BSTation<st>:CGROUP<di0>:COFFset<ch>:
CCODing:SREPetition? on page 115
```

### Symbol Puncture

Indicates the symbol puncture rate. The value is specific for the selected radio configuration.

Symbol puncturing (elimination) is used together with block symbol repetition for adapting the convolutional or turbo coder output data rate to the required input data rate of the interleaver.

Remote command:

```
[ :SOURce<hw> ] :BB:C2K:BSTation<st>:CGROUP<di0>:COFFset<ch>:
CCODing:SPUNcture? on page 114
```

### Data Rate

Indicates the effective data rate. The value is specific for the selected radio configuration.

For coding modes "Interleaving Only" and "Coding Off", the effective data rate differs from the set data rate. This is because no increase in the data rate is brought about by the convolution coder. The data rate set in the channel table is therefore not correct.

For coding modes "Without Interleaving" and "Complete", the data rate in the channel table agrees with the effective data rate. This is because there is an increase in the data rate due to the convolution coder.

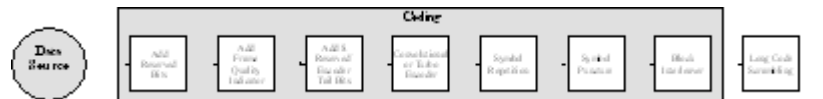

Remote command:

`[ :SOURCE<hw> ] :BB:C2K:BSTation<st>:CGROUP<di0>:COFFset<ch>:CCoding:DATA:RATE?` on page 113

### Block Interleaver

Displays the number of symbols that the interleaver processes per block. The indicated value is specific for the selected radio configuration.

Remote command:

`[ :SOURCE<hw> ] :BB:C2K:BSTation<st>:CGROUP<di0>:COFFset<ch>:CCoding:BINterleaver?` on page 112

#### 3.6.5.4 Additional Sync Channel Parameters

1. To access this dialog, select "CDMA 2000 > General > Link Direction > Downlink / Forward".
2. Select "Base Stations > Select Base Station > BS1...BS4".
3. Select "Channel Table > F-SYNC > More Params > Config".

CDMA2000: BS1/More Parameters CH0-5		
Common	Channel Coding	Additional Sync. Channel
CDMA Channel Number		387
P_REV		6
MIN_P_REV		2
SID		10
NID		1

This section contains the additional parameters for the channel type F-SYNC.

#### CDMA Channel Number - More Params BS

Displays the CDMA channel number which corresponds to the RF.

Remote command:

`[ :SOURCE<hw> ] :BB:C2K:BSTation:SYNC:CNUMBER` on page 109

#### System Time - More Params BS

Displays the system time.

Remote command:

`[ :SOURCE<hw> ] :BB:C2K:BSTation:SYNC:STIME` on page 111

#### LC State (hex) - More Params BS

Defines the long code state in hexadecimal format.

Remote command:

`[ :SOURCE<hw> ] :BB:C2K:BSTation:SYNC:LCSTATE` on page 109

#### P\_REV - More Params BS

Displays the Protocol revision level that specifies the CDMA2000 system release number.

The table below gives the cross-reference between the P\_REV values and the CDMA2000 releases.

P_REV	CDMA2000 release
1	Korean PCS(Band Class4), USPCS(Band Class1)
2	IS-95
3	TBS74
4	IS-95A
5	IS-95B
6	IS2000 Release 0
7	IS2000 Release A
8	IS2000 Release B

Remote command:

`[ :SOURCE<hw> ] :BB:C2K:BSTation:SYNC:PREV` on page 110

#### MIN\_P\_REV - More Params BS

Displays the minimum protocol revision level.

The BS sets this field to prevent mobile stations which cannot be supported by the BS from accessing the CDMA system.

Remote command:

`[ :SOURCE<hw> ] :BB:C2K:BSTation:SYNC:MPREV` on page 110

**SID - More Params BS**

Displays the system identification.

The BS sets the system identification number.

Remote command:

`[ :SOURCE<hw> ] :BB:C2K:BSTation:SYNC:SID` on page 111

**NID - More Params BS**

Displays the network identification.

The NID serves as a subidentifier of a CDMA system as defined by the owner of the SID.

Remote command:

`[ :SOURCE<hw> ] :BB:C2K:BSTation:SYNC:NID` on page 110

**3.6.6 More Parameters for F-PDCH - BS**

1. To access this dialog, select "CDMA 2000 > General > Link Direction > Downlink / Forward".
2. Select "Basestations > Basestation > BS1...BS4".
3. Select "Channel Table > F-PDCH > More Params > Config".

State	SPID	Time Slot Offset	Number of Bits per Encoder Packet	Number of 32-Chip Walsh Channels	Subpacket Data Rate (kbps)	Number of Slots per Subpacket	Modulation
On	0	0	2328	28	1862.4	1	8-PSK
On	0	1	2328	28	1862.4	1	8-PSK
On	0	2	2328	28	1862.4	1	8-PSK

Subpacket # 1 :  
 31, 15, 23, 7, 27, 11,  
 19, 3, 30, 14, 22, 6,  
 26, 10, 18, 2, 29, 13,  
 21, 5, 25, 9, 17, 1,  
 28, 12, 20, 4

Legend:  
 SPID = 0 (Cyan)  
 SPID = 1 (Red)  
 SPID = 2 (Yellow)  
 SPID = 3 (Green)

Power / dB vs Time / ms plot showing Walsh codes for SPID 0 (Cyan) at 0, 2.5, and 5 ms.

This dialog contains the settings required for configuring the packet channel F-PDCH.

The settings for the packet channel F-PDCH channel and all other channels are different (see [Chapter 3.6.5, "More Parameters - BS Channel Table"](#), on page 56 ). The dialog for the special channels and the traffic channels is described below.

The channel coding for the F-PDCHs is always carried out in full (see 3GPP2 C.S0002-C figure 3.1.3.1.1.1-19).

The parameters of both F-PDCCHs (such as Number of Slots per Subpacket, Subpacket Position) are implicitly defined by the F-PDCH settings, since both these channels are always transmitted simultaneously with the F-PDCH. The "More Parameters" dialog for these F-PDCCHs is therefore mostly for display, it only enables you to select the channel coding mode.

The left part is used to enter the general settings for the packet channel.

The right, upper part contains a table for setting the parameters of the subpackets. Up to eight subpackets can be transmitted for each regular packet.

The right, lower part displays the current configuration of the packet channel in graphical form.

### 3.6.6.1 General Settings for Packet Channel

In the left section, you can configure the general settings for the packet channel.

#### Packet Interval - More Params F-PDCHs BS

Selects the interval at which new data packets arrive.

New F-PDCH packets are generated in this interval. Within an interval, up to eight subpackets of a data packet can be transmitted with any required time offset.

The value range depends on the set sequence length (ARB settings). The values 80 ms, 40 ms, 20 ms, 10 ms and 5 ms can always be set, and the maximum value is 2000 ms. All intermediate values must satisfy the condition:

$$\text{Sequence Length} = * 80\text{ms}/2^n$$

where n is a whole number.

#### Example:

Sequence length = one 80 ms frame.

The possible values for the packet interval are 80 ms, 40 ms, 20 ms, 10 ms and 5 ms.

Sequence length = three 80 ms frames.

The possible values for the packet interval are 240 ms, 120 ms, 80 ms, 40 ms, 20 ms, 10 ms and 5 ms.

Remote command:

[\[:SOURCE<hw>\]:BB:C2K:BSTation<st>:PDCHannel:PINTERval](#) on page 127

#### Walsh Code Column Index - More Params F-PDCHs BS

Selects the standard-compliant set of available Walsh codes for the F\_PDCH (see 3GPP2 C.S0003-C, table 2-35).

Remote command:

[\[:SOURCE<hw>\]:BB:C2K:BSTation<st>:PDCHannel:WINDEX](#) on page 134

#### Same Packet Setup for all Subpackets - More Params F-PDCHs BS

Activates that all subpackets are generated with the same settings.

If enabled, you can only set the parameters of subpackage1 (number of bits, etc., see [Subpacket Table Settings](#)). The same settings are automatically assigned to all sub-packets.

The "Off" setting allows individual settings for each subpacket.

Remote command:

`[ :SOURCE<hw> ] :BB:C2K:BSTation<st>:PDCHannel:PSETup` on page 128

### 3.6.6.2 Subpacket Table Settings

The middle part contains a table for setting the parameters of the subpackets. Up to eight subpackets can be transmitted for each regular packet (Encoder Packet).

	State	SPID	Time Slot Offset	Number of Bits per Encoder Packet	Number of 32-Chip Walsh Channels	Subpacket Data Rate (kbps)	Number of Slots per Subpacket	Modulation
1	On	0	0	2328	28	1862.4	1	8-PSK
2	On	0	1	2328	28	1862.4	1	8-PSK
3	On	0	2	2328	28	1862.4	1	8-PSK
4	On	0	3	2328	28	1862.4	1	8-PSK

#### Subpacket Number - More Params F-PDCHs BS

Denotes the index number of the subpackets in the selected channel. Each packet can include up to eight subpackets.

The subpacket is selected by the suffix to `SUBPacket` in remote control.

#### Subpacket State - More Params F-PDCHs BS

Activates a subpacket.

Subpacket 1 is always active. The rest can be turned on and off.

Remote command:

`[ :SOURCE<hw> ] :BB:C2K:BSTation<st>:PDCHannel:SUBPacket<di>:STATE` on page 133

#### Subpacket ID (SPID) - More Params F-PDCHs BS

Selects the subpacket ID.

The subpacket ID controls the subpacket symbol selection and adopts one of four possible subpackets from the encoder packet.

The ID of the first subpacket is fixed at 0. The ID can be chosen for each of the rest.

Remote command:

`[ :SOURCE<hw> ] :BB:C2K:BSTation<st>:PDCHannel:SUBPacket<di>:ID` on page 128

#### Time Slot Offset - More Params F-PDCHs BS

Sets the starting time of the subpacket relative to the starting time of the packet interval.

The first subpacket always has an offset of 0, which cannot be changed.

The value range for the individual subpackets depends on the settings of the other subpackets:

The time slot offsets of the remaining subpackets must be entered in ascending order. Also it is not permitted to transmit two packets simultaneously.

**Example:**

Subpacket 2 is transmitted in time slot 5 and is four slots long. Subpacket 3 can only be transmitted in time slot 9 and no sooner.

In total, the value range is 0 to (Packet Interval/1.25 ms -Number of Slots per Subpacket).

**Example:**

Packet Interval = 20 ms, Number of Slots per Subpacket = 2. The value range is 0 to 14.

The entry for "Number of Slots per Subpacket" defines the length of a packet.

Remote command:

```
[ :SOURce<hw> ] :BB:C2K:BSTation<st>:PDCHannel:SUBPacket<di>:
TOFFset on page 133
```

**PDCH Subpacket Table Parameters - More Params F-PDCHs BS**

Only certain combinations of this parameter with the parameters of the last five table columns are possible. These combinations are shown in the selection list in the form of a table for all five parameters.

"Number of Bits per Encoder Packet"

Sets the number of bits per encoder packet.

The "Number of Bits per Encoder Packet" defines the number of data bits that can be read from the data source for an encoder packet. Due to the channel coding, this number is multiplied by a factor of about 5. The subsequent subpacket symbol selection then divides these bits into four different subpackets which can be selected via the SPID parameter.

The "Number of Bits per Encoder Packet" can only be changed for subpacket 1. This value must be identical for the remaining subpackets, since they are all part of a single encoder packet.

"Number of 32-Chip Walsh Channels"

Selects the number of 32-chip Walsh channels.

"Subpacket Data Rate (kbps)"

Selects the data rate of the subpacket.

The data rate is the result of the "Number of Bits per Encoder Packet" divided by the duration of the subpacket (= "Number of Slots per Subpacket"). Therefore only specified combinations of the "Subpacket Data Rate" with the "Number of Slots per Subpacket" at a specified "Number of Bits per Encoder Packet" are possible.

**"Number of Slots per Subpacket"**

Selects the number of slots per subpacket. This parameter defines the duration of the subpacket. A slot equals 1.25 ms.

The "Number of Slots per Subpacket" is the result of the "Number of Bits per Encoder Packet" divided by the data rate. Therefore only specified combinations of the Subpacket Data Rate with the "Number of Slots per Subpacket" at a specified "Number of Bits per Encoder Packet" are possible.

**"Modulation"**

Indication of the modulation type.

The modulation type is fix for each combination of the above parameters.

Remote command:

```
[ :SOURce<hw> ] :BB:C2K:BSTation<st>:PDCHannel:SUBPacket<di>:
PARAmeters on page 128
```

**Resulting Walsh Codes - More Params F-PDCHs BS**

Indicates the resulting Walsh codes for the subpacket.

Remote command:

```
[ :SOURce<hw> ] :BB:C2K:BSTation<st>:PDCHannel:SUBPacket<di>:
WCODes? on page 134
```

**3.6.6.3 Subpacket Graph**

Displays the current configuration of the packet channel and its active subpackets graphically.

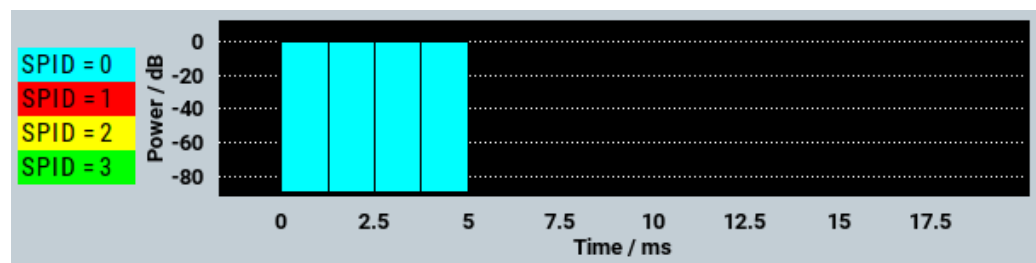

The X axis is the length of the set packet interval in ms, i.e. the duration of the transmission of an encoder packet.

The relative power of the subpackets is represented on the Y axis. The subpackets are shown as bars and are one, two or four time slots wide according to the configuration. The position on the X axis corresponds to the selected time slot offset.

The color of the bar depends on the sub packet ID (SPID). The assignment of colors to SPIDs is shown below the graph.

### 3.6.7 Mobile Station Configuration (MS)

1. To access this dialog, select "CDMA 2000 > General > Transmission Direction > Uplink / Reverse".
2. Select "Mobile Stations > Mobile Station > MS1...MS4".

The structure of the channel table depends on the selected operating mode and - for the traffic channel - on the selected radio configuration.

#### 3.6.7.1 Common Settings - MS

1. To access this dialog select "CDMA2000 > Mobile Station > MS1..MS4".
2. Select "MS1...MS4 > Common".

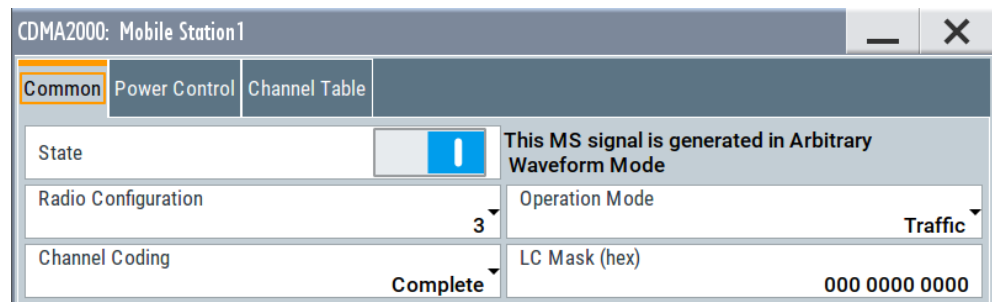

This dialog comprises the common settings required for configuring the mobile station.

#### State - MS

Activates or deactivates the selected mobile station. The number of the selected mobile station is specified in the dialog header.

Remote command:

[\[:SOURCE<hw>\]:BB:C2K:MSTation<st>:STATE](#) on page 146

#### Operation Mode - MS

Selects the mode in which the mobile station is to work.

The operation mode defines the generated channel types. The lower part of the dialog changes in accordance with the mode. The following modes are available:

- |           |  |
|-----------|--|
| "Traffic" | In this mode, the instrument generates a single traffic channel. A traffic channel consists of up to eight sub channels depending on the selected radio configuration.<br>This mode corresponds to the standard mode of a mobile station during voice and data transmission. |
| "Access"  | In this mode, the instrument generates an access channel (R-ACH). This channel is needed to set up the connection between the mobile station and the base station.   |

"Enhanced Access" In this mode, the instrument generates an enhanced access channel (R-ACH) and a pilot channel (R-PICH). These channels are used to set up the connection between the mobile station and the BS.

"Common Control" In this mode, the instrument generates a common control channel (R-ACH) and a pilot channel (R-PICH).

Remote command:

`[ :SOURce<hw> ] :BB:C2K:MSTation<st>:MODE` on page 145

### Radio Configuration - MS

Selects the radio configuration for the traffic channel.

In the reverse link, the channel scenario with the spreading codes of the individual channels is predefined by selecting the radio configuration. For this reason, the channel table does not contain selection parameters for the Walsh code.

A separate set of settings of all channel table parameters is provided for each radio configuration. Changing the radio configuration causes the settings belonging to the new RC value to be activated in the channel table. The settings belonging to the old RC value are not lost.

The radio configuration determines the permissible frame lengths and the frame length defines the permitted data rate.

Changing the frame length automatically causes the data rate to be changed if it is no longer permitted.

Remote command:

`[ :SOURce<hw> ] :BB:C2K:MSTation<st>:RCONfiguration` on page 146

### Channel Coding - MS

Activates or deactivates channel coding.

"Off" Channel coding is deactivated.

"Complete" The complete channel coding is performed. The channel coding procedure can slightly vary depending on channel type, frame length and data rate.

"Without Interleaving" Except for the block interleaver, the whole channel coding procedure is carried out.

"Interleaving Only" In this mode, only block interleaver is used for coding.

Remote command:

`[ :SOURce<hw> ] :BB:C2K:MSTation<st>:CCODing:MODE` on page 140

### LC Mask (hex) - MS

Enters the mask of the long-code generator in hexadecimal form.

The long-code mask is a 42-bit value. The mask serves for channel-specific and user-specific scrambling of the code channel.

Remote command:

`[ :SOURce<hw> ] :BB:C2K:MSTation<st>:LCMask` on page 145

### 3.6.7.2 Power Control - MS

1. To access this dialog select "Mobile Stations > Select Mobile Station> MS1..MS4".
2. Select "MS1...MS4 > Power Control".

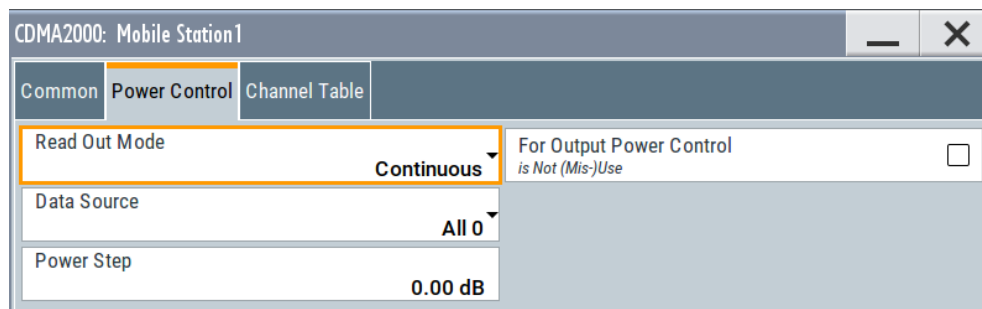

This dialog contains the parameters for configuring the power control bits for mobile stations.

In the uplink, the bits are used exclusively for controlling the mobile station output power by activating the "(Mis-)Use Power Control" function. Power control puncturing of the data bits of the traffic channels for controlling the base station power is not performed.

This section is only available for the traffic channel.

#### Read Out Mode (Power Control) - MS

Defines a read-out mode of power control bits.

Together with the parameter [For Output Power Control - MS](#), this parameter can also be used to generate various output power profiles.

- |                    |  |
|--------------------|--|
| "Continuous"       | The power control bits are used cyclically.  |
| "Single + All 0"   | The power control bits are used once and then the power control sequence is continued with 0 bits.                       |
| "Single + All 1"   | The power control bits are used once and then the power control sequence is continued with 1 bit.                        |
| "Single + Alt. 01" | The power control bits are used once and then the power control sequence is continued with 0 bits and 1 bit alternately. |
| "Single + Alt. 10" | The power control bits are used once and then the power control sequence is continued with 1 bit and 0 bits alternately. |

Remote command:

[\[:SOURCE<hw>\]:BB:C2K:MSTation<st>:TPC:READ](#) on page 148

#### Data Source (Power Control) - MS

Defines the data source for the power control bits of the channel.

The following standard data sources are available:

- "All 0, All 1"  
An internally generated sequence containing 0 data or 1 data.
- "PNxx"

- An internally generated pseudo-random noise sequence.
- "Pattern"
  - An internally generated sequence according to a bit pattern.
  - Use the "Pattern" box to define the bit pattern.
- "Data List/Select DList"
  - A binary data from a data list, internally or externally generated.
  - Select "Select DList" to access the standard "Select List" dialog.
    - Select the "Select Data List > navigate to the list file \*.dm\_iqd > Select" to select an existing data list.
    - Use the "New" and "Edit" functions to create internally new data list or to edit an existing one.
    - Use the standard "File Manager" function to transfer external data lists to the instrument.

See also:

- Section "Modulation Data" in the R&S SMW user manual.
- Section "File and Data Management" in the R&S SMW user manual.
- Section "Data List Editor" in the R&S SMW user manual

Remote command:

[\[:SOURce<hw>\]:BB:C2K:MSTation<st>:TPC:DATA](#) on page 146

[\[:SOURce<hw>\]:BB:C2K:MSTation<st>:TPC:DATA:PATtern](#) on page 147

[\[:SOURce<hw>\]:BB:C2K:MSTation<st>:TPC:DATA:DSElect](#) on page 147

### For Output Power Control - MS

Activates "(Mis-)Use" of the power control data.

In the uplink, the power control bits are used exclusively for controlling the mobile station output power. Power control puncturing is not defined for controlling the BS power.

If "For Output Power Control > (Mis-)Use" is activated, the specified pattern is used to vary the intrinsic transmit power over time. Every 1.25 ms (800 Hz) a bit of this pattern is removed in order to increase (bit = "1") or reduce (bit = "0") the channel power by the specified "Power Step". The upper limit is 0 dB and the lower limit -80 dB.

The following envelope is produced with the settings:

- Channel power = 0 dB
- Power step = 1.0 dB
- Pattern = "001110100000011"
- "TPC Read Out Mode = Continuous"

**Note:** The first bit is assigned to the first power control section. In this first section, the start power specified in the channel table is always used. Only in the next power control section (with the second power control bit) will the defined power change be effective.

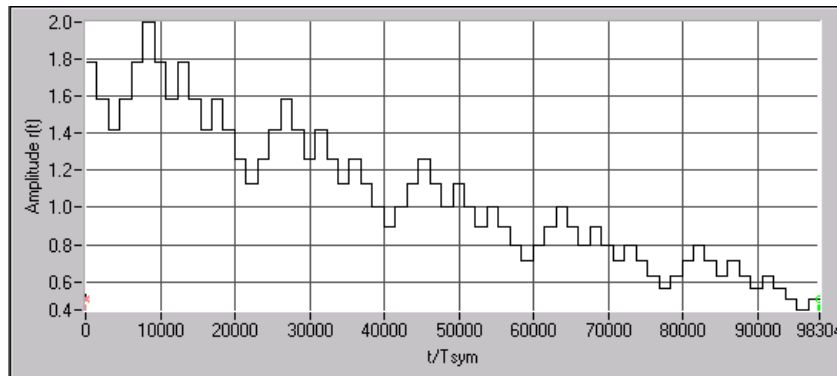

Figure 3-4: Dynamic change of channel power (continuous)

Remote command:

`[ :SOURCE<hw> ] :BB:C2K:MSTation<st>:TPC:MISuse` on page 148

### Power Step - MS

Sets the step width of the power change in dB for "(Mis-) use TPC for output power control".

Remote command:

`[ :SOURCE<hw> ] :BB:C2K:MSTation<st>:TPC:PSTep` on page 148

### 3.6.7.3 Channel Table - MS

1. To access this dialog select "Mobile Stations > Select Mobile Station> MS1..MS4".
2. Select "MS1...MS4 > Channel Table".

CDMA2000: Mobile Station1									
Common		Power Control		Channel Table					
Channel Type	Frame Length / ms	Data Rate / kbps	Walsh	Spread	Power / dB	Data	Dist Pattern	State	
1 R-PICH	20.0	NotUsd	0	32	0.00	PN 9		On	
2 R-DCCH	20.0	9.6	8	16	0.00	PN 9		Off	
3 R-FCH	20.0	1.5	4	16	0.00	PN 9		Off	
4 R-SCH1	20.0	1.5	2	16	0.00	PN 9		Off	
5 R-SCH2	20.0	1.5	6	16	0.00	PN 9		Off	

This table contains the channel table for configuring the channel parameters individually.

The structure of the channel table depends on the selected operating mode and - for the traffic channel - on the selected radio configuration. Also, for the traffic channels, the indicated values and the settings are specific for the selected radio configuration.

In uplink, the employed Walsh code is determined by the radio configuration and cannot be chosen.

The following combinations between the operating modes of the four mobile stations are allowed:

	Traffic, RC1 & RC 2	Traffic, RC3 & RC 4	Access	Enhanced access	Common Control
Traffic, RC1 & RC 2	X		X		
Traffic, RC3 & RC 4		X		X	X
Access	X		X		
Enhanced access		X		X	X
Common control		X		X	X

#### Channel Number- MS

Displays the channel number.

All channels of the selected operating mode are listed. The channels are switched on and off with the "On/Off" button in the "State" column.

Remote command:

n.a.

#### Channel Type - MS

Indicates the channel type (see [Table 3-2](#)). The possible channel types depend on the selected operating mode of the mobile station.

**Table 3-2: List of supported channel types**

Short form	Name	Function
<b>Traffic</b>		
R-PICH	Reverse Pilot Channel	Provides the capabilities for coherent detection.
R-DCCH	Reverse Dedicated Control Channel	Transports mobile-specific control information.
R-FCH	Reverse Fundamental Channel	Similar to F-FCH; designed to transport dedicated data.
R-SCH	Reverse Supplemental Channel (RC 3...5)	Allocated dynamically to meet a required data rate.
R-SCCH	Reverse Supplemental Code Channel (RC 1 / 2)	Allocated dynamically to meet a required data rate.
<b>Access</b>		
R-ACH	Reverse Access Channel	Required connection set up between the mobile station and the base station.

Short form	Name	Function
<b>Enhanced Access</b>		
R-EACH	Reverse Enhanced Access Channel	Required connection set up between the mobile station and the base station.
R-PICH	Reverse Pilot Channel	Provides the capabilities for coherent detection.
<b>Common Control</b>		
R-CCCH	Reverse Common Control Channel	Similar to R-ACH but it is meant to transport control information.

Remote command:

`[ :SOURCE<hw> ] :BB:C2K:MSTation<st>:CHANnel<ch>:TYPE?` on page 144

### Frame Length - MS

Sets the frame length of the channel. For the traffic channels, the indicated value is specific for the selected radio configuration.

The value range depends on the channel type and the selected radio configuration. The frame length of some channels is fixed. The maximum frame length is 80 ms, the minimum frame length is 5 ms.

The frame length affects the data rates that are possible within a channel. If a frame length is changed so that the set data rate becomes invalid, the next permissible value is automatically set.

Remote command:

`[ :SOURCE<hw> ] :BB:C2K:MSTation<st>:CHANnel<ch>:FLENgth` on page 142

### Data Rate - MS

Sets the data rate of the channel. For the traffic channels, the indicated value is specific for the selected radio configuration.

The R&S SMW supports all data rates between 1.2 kbps and 1,036.8 kbps defined in the standard.

The value range depends on the frame length. If one of these parameters is changed so that the set data rate becomes invalid, the next permissible value is automatically set.

Remote command:

`[ :SOURCE<hw> ] :BB:C2K:MSTation<st>:CHANnel<ch>:DATA:RATE`  
on page 142

### Walsh - MS

Assigns the Walsh code to the channel (see [Chapter 2.1.9, "Spreading - Uplink"](#), on page 16). For the traffic channels, the indicated value is specific for the selected radio configuration.

The code channel is spread with the set Walsh code (spreading code). The Walsh codes to be used are specified by the standard and cannot be chosen.

Remote command:

[ :SOURce<hw> ] :BB:C2K:MSTation<st>:CHANnel<ch>:WCOde? on page 144

### Spread- MS

Indication of the spreading factor of the channel. For the traffic channels, the indicated value is specific for the selected radio configuration.

The spreading factor corresponds to the length of the employed Walsh code. The Walsh codes to be used are specified by the standard and cannot be chosen.

Remote command:

[ :SOURce<hw> ] :BB:C2K:MSTation<st>:CHANnel<ch>:SPReading?  
on page 143

### Power - MS

Enters the channel power in dB. For the traffic channels, the set value is specific for the selected radio configuration.

The power entered is relative to the power's output of the other channels. If "Adjust Total Power to 0 dB" is executed (top level of the CDMA2000 dialog), all the power data is relative to 0 dB.

The set power value is also the start power of the channel, if "For Output Power Control > (Mis-)Use" is activated.

**Note:** The maximum channel power of 0 dB applies to non-blanked channels (duty cycle 100%). With blanked channels, the maximum value can be increased (by "Adjust Total Power") to values greater than 0 dB.

Remote command:

[ :SOURce<hw> ] :BB:C2K:MSTation<st>:CHANnel<ch>:POWER on page 143

### Data - MS

Selects data source. For the traffic channels, the set value is specific for the selected radio configuration.

The following standard data sources are available:

- "All 0, All 1"  
An internally generated sequence containing 0 data or 1 data.
- "PNxx"  
An internally generated pseudo-random noise sequence.
- "Pattern"  
An internally generated sequence according to a bit pattern.  
Use the "Pattern" box to define the bit pattern.
- "Data List/Select DList"  
A binary data from a data list, internally or externally generated.  
Select "Select DList" to access the standard "Select List" dialog.
  - Select the "Select Data List > navigate to the list file \*.dm\_iqd > Select" to select an existing data list.
  - Use the "New" and "Edit" functions to create internally new data list or to edit an existing one.
  - Use the standard "File Manager" function to transfer external data lists to the instrument.

See also:

- Section "Modulation Data" in the R&S SMW user manual.
- Section "File and Data Management" in the R&S SMW user manual.
- Section "Data List Editor" in the R&S SMW user manual

Remote command:

`[ :SOURce<hw> ] :BB:C2K:MSTation<st>:CHANnel<ch>:DATA` on page 140

`[ :SOURce<hw> ] :BB:C2K:MSTation<st>:CHANnel<ch>:DATA:PATtern`

on page 141

`[ :SOURce<hw> ] :BB:C2K:MSTation<st>:CHANnel<ch>:DATA:DSElect`

on page 141

### Channel State - MS

Activates/deactivates the channel. For the traffic channels, the indicated value is specific for the selected radio configuration.

Remote command:

`[ :SOURce<hw> ] :BB:C2K:MSTation<st>:CHANnel<ch>:STATe` on page 143

## 3.7 Filter / Clipping / ARB Settings

Access:

- ▶ Select "General > Filter/Clipping/ARB Settings".

The dialog comprises the settings, necessary to configure the baseband filter, to enable clipping and adjust the sequence length of the arbitrary waveform component.

### 3.7.1 Filter Settings

Access:

- ▶ Select "Filter".

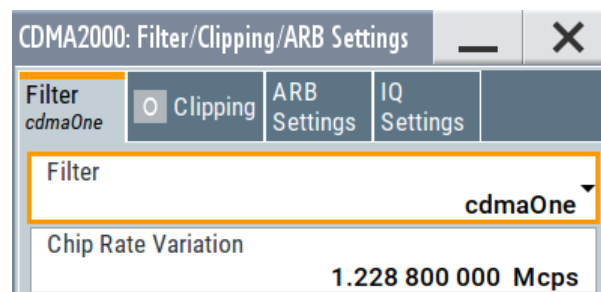

The dialog contains the parameters required for configuring the baseband filter.

**Settings:****Filter**

Selects the baseband filter.

Remote command:

[ :SOURce<hw> ] :BB:C2K:FILTER:TYPE on page 91

**Chip Rate Variation**

Enters the chip rate.

Remote command:

[ :SOURce<hw> ] :BB:C2K:CRATE:VARIation on page 86

**Roll Off Factor or BxT**

Sets the filter parameter.

The filter parameter ("Roll off Factor" or "BxT") depends on the currently selected filter type. This parameter is preset to the default for each of the predefined filters.

Remote command:

[ :SOURce<hw> ] :BB:C2K:FILTER:PARAMeter:APCO25 on page 91

[ :SOURce<hw> ] :BB:C2K:FILTER:PARAMeter:COSine on page 91

[ :SOURce<hw> ] :BB:C2K:FILTER:PARAMeter:GAUSS on page 92

[ :SOURce<hw> ] :BB:C2K:FILTER:PARAMeter:PGAuss on page 93

[ :SOURce<hw> ] :BB:C2K:FILTER:PARAMeter:RCOSine on page 93

[ :SOURce<hw> ] :BB:C2K:FILTER:PARAMeter:SPHase on page 93

**Cutoff Frequency Factor**

Sets the value for the cutoff frequency factor. The cutoff frequency of the filter can be adjusted to reach spectrum mask requirements.

Remote command:

[ :SOURce<hw> ] :BB:C2K:FILTER:PARAMeter:LPASs on page 92

[ :SOURce<hw> ] :BB:C2K:FILTER:PARAMeter:LPASSEVM on page 92

### 3.7.2 Clipping Settings

- ▶ To access this dialog, select "Clipping".

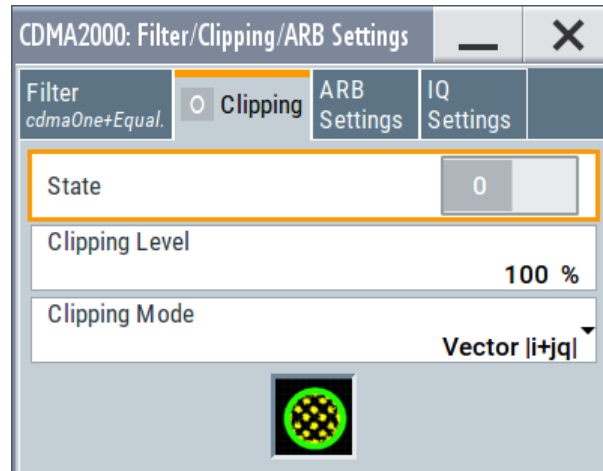

The dialog comprises the settings, necessary to configure the clipping.

#### Clipping State

Switches baseband clipping on and off.

Baseband clipping is a simple and effective way of reducing the crest factor of the signal. Since clipping is done before to filtering, the procedure does not influence the spectrum. The EVM however increases.

Remote command:

[\[:SOURCE<hw>\]:BB:C2K:CLIPPING:STATE](#) on page 95

#### Clipping Level

Sets the limit for clipping.

This value indicates at what point the signal is clipped. It is specified as a percentage, relative to the highest level. 100% indicates that clipping does not take place.

Remote command:

[\[:SOURCE<hw>\]:BB:C2K:CLIPPING:LEVEL](#) on page 94

#### Clipping Mode

Selects the clipping method. The dialog displays a graphical illustration on how this two methods work.

- "Vector  $|i + jq|$ "  
The limit is related to the amplitude  $|i + q|$ . The I and Q components are mapped together, the angle is retained.
- "Scalar  $|i|, |q|$ "  
The limit is related to the absolute maximum of all the I and Q values  $|i| + |q|$ . The I and Q components are mapped separately, the angle changes.

Remote command:

[\[:SOURCE<hw>\]:BB:C2K:CLIPPING:MODE](#) on page 94

### 3.7.3 ARB Settings

- ▶ To access this dialog, select "ARB Settings".

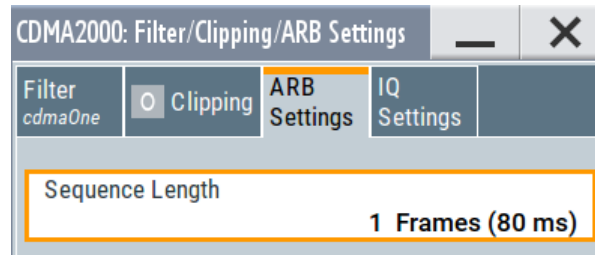

The dialog comprises the settings, required to adjust the sequence length of the arbitrary waveform component.

#### Sequence Length ARB

Changes the sequence length of the arbitrary waveform component of the signal. This component is calculated in advance and output in the arbitrary waveform generator.

The number of chips is determined from this sequence length (1 Frame = 80 ms) and the chip rate. At 1.2288 MChips/s, a frame equals 98.304 chips.

In pure amplifier tests with several channels and no realtime channels, it is possible to improve the statistical properties of the signal by increasing the sequence length.

**Note:** Unlike for 3GPP, in the case of CDMA2000 the length of a frame is not uniformly defined. This implementation uses a frame length of 80 ms. Division into 80 ms frames was chosen because in this time grid the frame lengths for both the SYNC channel, with its cycle duration of 26.67 ms, and all other channels work out to 5 ms, 10 ms, 20 ms or 80 ms. The F-BCH has a frame length of 160 ms. In order to use this channel, an even number of 80 ms frames has to be set.

Remote command:

[ :SOURce<hw> ] :BB:C2K:SLENgth on page 89

### 3.7.4 I/Q Setting

- ▶ To access this dialog, select "IQ Settings".

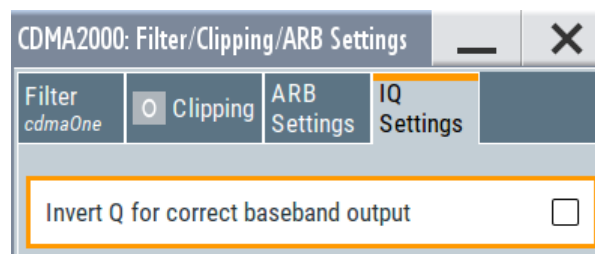

This dialog contains the parameters for configuring the IQ settings.

**Invert Q for Correct Baseband Output**

Inverts Q-part of the baseband signal, see [Chapter 2.1.12, "I/Q Modulator - Uplink and Downlink"](#), on page 19.

With its default CDMA2000 settings, the R&S SMW generates a standard compliant *RF* signal.

If a standard compliant *baseband* signal is required, enable this parameter to invert the Q-part of the baseband signal.

If both, the RF signal and baseband signal have to be compliant with the CDMA2000 standard:

- Set "Invert Q for Correct Baseband Output > On"
- Set "I/Q Mod > I/Q Settings > I/Q Swap > On"

See also R&S SMW user manual, section "Applying I/Q Vector Modulation".

Remote command:

`[ :SOURCE<hw> ] :BB:C2K:IQSWap [ :STATe ]` on page 87

## 4 Remote-Control Commands

The following commands are required to perform signal generation with the CDMA2000 options in a remote environment. We assume that the R&S SMW has already been set up for remote operation in a network as described in the R&S SMW documentation. Knowledge of the remote control operation and the SCPI command syntax is assumed.



### Conventions used in SCPI command descriptions

For a description of the conventions used in the remote command descriptions, see section "Remote Control Commands" in the R&S SMW user manual.

The commands in the `SOURCE:BB:C2K` subsystem are described in several sections, separated into general remote commands, commands for base station settings and commands for mobile station settings.

### Common suffixes

The following common suffixes are used in remote commands:

Suffix	Value range	Description
ENTity<ch>	1 to 4	entity in a multiple entity configuration with separate base-band sources ENTity3 4 require option R&S SMW-K76
SOURCE<hw>	[1] to 4	available baseband signals only SOURCE1 possible, if the keyword ENTity is used
OUTPut<ch>	1 to 3	available markers
BSTation<st>	[1] 2 3 4	base station
CGRoup<di0> COFFset<ch>	0 [1]..8 [1]..13	See "Suffixes" on page 107
MSTation<st>	[1] 2 3 4	mobile station
CHANnel<ch>	0 [1]..8	uplink channel



### Using SCPI command aliases for advanced mode with multiple entities

You can address multiple entities configurations by using the SCPI commands starting with the keyword `SOURCE` or the alias commands starting with the keyword `ENTity`.

Note that the meaning of the keyword `SOURCE<hw>` changes in the second case.

For details, see section "SCPI Command Aliases for Advanced Mode with Multiple Entities" in the R&S SMW user manual.

The following commands specific to the CDMA2000 are described here:

• Primary Commands.....	84
• Filter/Clipping Settings.....	91
• Trigger Settings.....	95
• Marker Settings.....	99
• Clock Settings.....	101
• Predefined Settings.....	102
• Base Stations Settings.....	107
• Mobile Station Settings.....	137

## 4.1 Primary Commands

[:SOURce<hw>]:BB:C2K:COPIY:COFFset.....	84
[:SOURce<hw>]:BB:C2K:COPIY:DESTination.....	85
[:SOURce<hw>]:BB:C2K:COPIY:EXECute.....	85
[:SOURce<hw>]:BB:C2K:COPIY:SOURce.....	85
[:SOURce<hw>]:BB:C2K:CRATe?.....	86
[:SOURce<hw>]:BB:C2K:CRATe:VARiation.....	86
[:SOURce<hw>]:BB:C2K:IQSWap[:STATe].....	87
[:SOURce<hw>]:BB:C2K:LINK.....	87
[:SOURce<hw>]:BB:C2K:POWer:ADJust.....	87
[:SOURce<hw>]:BB:C2K:POWer[:TOTal]?.....	87
[:SOURce<hw>]:BB:C2K:PRESet.....	88
[:SOURce<hw>]:BB:C2K:SETTing:CATalog?.....	88
[:SOURce<hw>]:BB:C2K:SETTing:DELeTe.....	88
[:SOURce<hw>]:BB:C2K:SETTing:LOAD.....	89
[:SOURce<hw>]:BB:C2K:SETTing:STORE.....	89
[:SOURce<hw>]:BB:C2K:SLENgth.....	89
[:SOURce<hw>]:BB:C2K:STATe.....	90
[:SOURce<hw>]:BB:C2K:WAVEform:CREate.....	90
[:SOURce]:BB:C2K:VERSion?.....	90

---

### [:SOURce<hw>]:BB:C2K:COPIY:COFFset <COFFset>

The command sets the offset for the Walsh code in the destination base station. The minimum value is 0 (Walsh codes are identical), the maximum value is 255.

This command is only available in the downlink (SOUR:BB:C2K:LINK FORW/DOWN).

#### Parameters:

<COFFset>	integer
	Range: 0 to 255
	Increment: 1
	*RST: 0

#### Example:

BB:C2K:COPIY:COFF 10  
the Walsh code is shifted by 10 when the source base station is copied to the destination base station.

**Manual operation:** See " Copy ... " on page 36

**[[:SOURce<hw>]:BB:C2K:COPY:DESTination <Destination>**

The command selects the station to which data is to be copied. Whether the data is copied to a base station or a mobile station depends on which transmission direction is selected (command `C2K:LINK UP | DOWN`).

**Parameters:**

<Destination>            1 | 2 | 3 | 4  
 Range:                    1 to 4  
 \*RST:                     2

**Example:**

`BB:C2K:LINK DOWN`  
 selects the downlink transmit direction (base station to mobile station).  
`BB:C2K:COPY:SOUR 1`  
 selects base station 1 as the source.  
`BB:C2K:COPY:DEST 4`  
 selects base station 4 as the destination.  
`BB:C2K:COPY:EXEC`  
 starts copying the parameter set of base station 1 to base station 4.

**Manual operation:** See "[Copy ...](#)" on page 36

**[[:SOURce<hw>]:BB:C2K:COPY:EXECute**

The command starts the copy process. The dataset of the source station is copied to the destination station. Whether the data is copied to a base station or a mobile station depends on which transmission direction is selected (command `:BB:C2K:LINK UP | DOWN`).

**Example:**

`BB:C2K:COPY:EXEC`  
 starts copying the parameter set of the selected source station to the selected destination station.

**Usage:** Event

**Manual operation:** See "[Copy ...](#)" on page 36

**[[:SOURce<hw>]:BB:C2K:COPY:SOURce <Source>**

The command selects the station that has data to be copied. Whether the station copied is a base or mobile station depends on which transmission direction is selected (command `C2K:LINK UP | DOWN`).

**Parameters:**

<Source>                    1 | 2 | 3 | 4  
 Range:                    1 to 4  
 \*RST:                     1

**Example:** `BB:C2K:LINK UP`  
selects the uplink transmit direction (mobile station to base station).

`BB:C2K:COPY:SOUR 1`  
selects mobile station 1 as the source.

`BB:C2K:COPY:DEST 4`  
selects mobile station 4 as the destination.

`BB:C2K:COPY:EXEC`  
starts copying the parameter set of mobile station 1 to mobile station 4.

**Manual operation:** See "[Copy ...](#)" on page 36

### **[:SOURce<hw>]:BB:C2K:CRATe?**

The command queries the spreading rate. The output chip rate which determines the rate of the spread symbols as is used for signal output can be set with the command `SOUR:BB:C2K:CRAT:VAR`.

**Return values:**

<CRate> R1M2  
\*RST: R1M2

**Example:** `BB:C2K:CRAT?`  
queries the system chip rate.  
Response:R1M2  
the system chip rate is 1.2288 Mcps.

**Usage:** Query only

**Manual operation:** See "[Spreading Rate](#)" on page 25

### **[:SOURce<hw>]:BB:C2K:CRATe:VARiation <Variation>**

Sets the output chip rate.

The output chip rate changes the output clock and the modulation bandwidth, as well as the synchronization signals that are output. It does not affect the calculated chip sequence.

**Parameters:**

<Variation> float  
Range: 400 to 5E6  
Increment: 1E-3  
\*RST: 1.2288E6

**Example:** `BB:C2K:CRAT:VAR 4086001`  
sets the chip rate to 4.08 Mcps.

**Manual operation:** See "[Chip Rate Variation](#)" on page 79

---

**[ :SOURce<hw>]:BB:C2K:IQSWap[:STATe] <State>**

This command inverts the Q-part of the baseband signal if set to ON. The signal on the baseband outputs meets the cdma2000 standard. In order to generate an RF signal that conforms to the standard, the "I/Q Swap" function in the "I/Q Modulator" menu must be enabled ("On") (SOURce:IQ:SWAP ON).

**Parameters:**

<State>                    0 | 1 | OFF | ON  
 \*RST:                    OFF

**Example:**                    BB:C2K:IQSW:STAT ON  
 inverts the Q-part of the baseband signal.

**Manual operation:**    See "[Invert Q for Correct Baseband Output](#)" on page 82

---

**[ :SOURce<hw>]:BB:C2K:LINK <Link>**

The command defines the transmission direction. The signal either corresponds to that of a base station (FORWARD | DOWN) or that of a mobile station (REVERSE | UP).

**Parameters:**

<Link>                    DOWN | UP | FORWARD | REVERSE  
 \*RST:                    DOWN

**Example:**                    BB:C2K:LINK DOWN  
 the transmission direction selected is base station to mobile station. The signal corresponds to that of a base station.

**Manual operation:**    See "[Link Direction](#)" on page 25

---

**[ :SOURce<hw>]:BB:C2K:POWER:ADJust**

The command sets the power of the active channels in such a way that the total power of the active channels is 0 dB. This does not change the power ratio among the individual channels.

**Example:**                    BB:C2K:POW:ADJ  
 The total power of the active channels is set to 0 dB, the power ratio among the individual channels is unchanged.

**Usage:**                    Event

**Manual operation:**    See "[Adjust Total Power to 0dB](#)" on page 37

---

**[ :SOURce<hw>]:BB:C2K:POWER[:TOTal]?**

The command queries the total power of the active channels. After "Power Adjust", this power corresponds to 0 dB.

**Return values:**

<Total> float  
 Range: -80 dB to 30 dB  
 Increment: 0.01 dB  
 \*RST: 0 dB

**Example:**

BB:C2K:POW?  
 queries the total power of the active channels.  
 Response: -22.5  
 the total power is -25 dB.

**Usage:** Query only

**Manual operation:** See "[Total Power](#)" on page 37

**[[:SOURce<hw>]:BB:C2K:PRESet**

Sets the parameters of the digital standard to their default values (\*RST values specified for the commands).

Not affected is the state set with the command `SOURce<hw>:BB:C2K:STATe`.

**Example:** `SOURce1:BB:C2K:PRESet`

**Usage:** Event

**Manual operation:** See "[Set to Default](#)" on page 24

**[[:SOURce<hw>]:BB:C2K:SETTing:CATalog?**

Queries the files with settings in the default directory. Listed are files with the file extension \*.cdma2k.

For general information on file handling in the default and in a specific directory, see section "MMEMory Subsystem" in the R&S SMW operating manual.

**Return values:**

<Catalog> <filename1>,<filename2>,...  
 Returns a string of filenames separated by commas.

**Example:**

```
MMEM:CDIR '/var/user/cdma'
SOURce1:BB:C2K:SETTing:CATalog?
// Response: "cdma_up", "cdma_down"
SOURce1:BB:C2K:SETTing:DELeTe "cdma_down"
SOURce1:BB:C2K:SETTing:LOAD "cdma_up"
```

**Usage:** Query only

**Manual operation:** See "[Save/Recall](#)" on page 25

**[[:SOURce<hw>]:BB:C2K:SETTing:DELeTe <Filename>**

Deletes the selected file from the default or the specified directory. Deleted are files with extension \*.cdma2k.

**Setting parameters:**

<Filename> string

**Example:** See `[ :SOURce<hw> ] :BB:C2K:SETTING:CATalog?`  
on page 88

**Usage:** Setting only

**Manual operation:** See "Save/Recall" on page 25

**[ :SOURce<hw> ] :BB:C2K:SETTING:LOAD <Filename>**

Loads the selected file from the default or the specified directory. Loaded are files with extension \*.cdma2k.

**Setting parameters:**

<Filename> "<filename>"

Filename or complete file path; file extension can be omitted

**Example:** See `[ :SOURce<hw> ] :BB:C2K:SETTING:CATalog?`  
on page 88

**Usage:** Setting only

**Manual operation:** See "Save/Recall" on page 25

**[ :SOURce<hw> ] :BB:C2K:SETTING:STORE <Filename>**

Stores the current settings into the selected file; the file extension (\*.cdma2k) is assigned automatically.

**Setting parameters:**

<Filename> string

Filename or complete file path

**Example:** `BB:C2K:SETT:STOR 'CDMA_UP'`

**Usage:** Setting only

**Manual operation:** See "Save/Recall" on page 25

**[ :SOURce<hw> ] :BB:C2K:SLENgth <SLength>**

Sets the sequence length of the arbitrary waveform component of the CDMA2000 signal in the number of frames.

**Parameters:**

<SLength> integer

Range: 1 to max

\*RST: 1

**Example:** `BB:C2K:SLEN 10`  
sets the sequence length to 10 frames.

**Manual operation:** See ["Sequence Length ARB"](#) on page 81

---

**[[:SOURce<hw>]:BB:C2K:STATe <State>**

Activates the standard and deactivates all the other digital standards and digital modulation modes in the same path.

**Parameters:**

<State>                    0 | 1 | OFF | ON  
 \*RST:                    0

**Example:**                    SOURce1:BB:C2K:STATe ON

**Manual operation:** See ["State"](#) on page 24

---

**[[:SOURce<hw>]:BB:C2K:WAVeform:CREate <Filename>**

This command creates a waveform using the current settings of the "CDMA2000" menu. The file name is entered with the command. The file is stored with the predefined file extension \*.wv. The file name and the directory it is stored in are user-definable.

**Setting parameters:**

<Filename>                string

**Example:**                    MMEM:CDIR "/var/user/temp/waveform"  
 sets the default directory to /var/user/temp/waveform.  
 BB:C2K:WAV:CRE "cdma\_bs"  
 creates the waveform file cdma\_bs.wv in the default directory.

**Usage:**                    Setting only

**Manual operation:** See ["Generate Waveform File"](#) on page 25

---

**[[:SOURce]:BB:C2K:VERSion?**

The command queries the version of the CDMA standard underlying the definitions.

**Return values:**

<Version>                string

**Example:**                    BB:C2K:VERS?  
 queries the CDMA version.  
 Response: Release C  
 CDMA Release 5

**Usage:**                    Query only

**Manual operation:** See ["CDMA 2000 Version"](#) on page 25

## 4.2 Filter/Clipping Settings

### 4.2.1 Filter Settings

<code>[:SOURce&lt;hw&gt;]:BB:C2K:FILTer:TYPe</code> .....	91
<code>[:SOURce&lt;hw&gt;]:BB:C2K:FILTer:PARAmeter:APCO25</code> .....	91
<code>[:SOURce&lt;hw&gt;]:BB:C2K:FILTer:PARAmeter:COSSine</code> .....	91
<code>[:SOURce&lt;hw&gt;]:BB:C2K:FILTer:PARAmeter:GAUSSs</code> .....	92
<code>[:SOURce&lt;hw&gt;]:BB:C2K:FILTer:PARAmeter:LPASs</code> .....	92
<code>[:SOURce&lt;hw&gt;]:BB:C2K:FILTer:PARAmeter:LPASSEVM</code> .....	92
<code>[:SOURce&lt;hw&gt;]:BB:C2K:FILTer:PARAmeter:PGAuss</code> .....	93
<code>[:SOURce&lt;hw&gt;]:BB:C2K:FILTer:PARAmeter:RCOSSine</code> .....	93
<code>[:SOURce&lt;hw&gt;]:BB:C2K:FILTer:PARAmeter:SPHase</code> .....	93

---

#### `[:SOURce<hw>]:BB:C2K:FILTer:TYPe <Type>`

The command selects the filter type.

##### Parameters:

<Type> RCOSine | COSine | GAUSSs | LGAuss | CONE | COF705 |  
COEQUALizer | COFEQUALizer | C2K3x | APCO25 | SPHase |  
RECTangle | PGAuss | LPASs | DIRac | ENPSHape |  
EWPSHape | LPASSEVM  
\*RST: Downlink:COEF; Uplink: CONE

##### Example:

`BB:C2K:FILT:TYPE CONE`  
sets the filter type CdmaOne. This filter type is defined by the  
standard for the uplink.

**Manual operation:** See "[Filter](#)" on page 79

---

#### `[:SOURce<hw>]:BB:C2K:FILTer:PARAmeter:APCO25 <Apco25>`

Sets the roll-off factor for filter type APCO25.

##### Parameters:

<Apco25> float  
Range: 0.05 to 0.99  
Increment: 0.01  
\*RST: 0.20

##### Example:

`BB:C2K:FILT:PAR:APCO25 0.2`  
Sets the roll-off factor to 0.2 for filter type APCO25.

**Manual operation:** See "[Roll Off Factor or BxT](#)" on page 79

---

#### `[:SOURce<hw>]:BB:C2K:FILTer:PARAmeter:COSSine <Cosine>`

Sets the roll-off factor for the Cosine filter type.

**Parameters:**

<Cosine> float  
 Range: 0 to 1.0  
 Increment: 0.01  
 \*RST: 0.35

**Example:**

BB:C2K:FILT:PAR:COS 0.35  
 Sets the roll-off factor to 0.35 for filter type Cosine.

**Manual operation:** See "[Roll Off Factor or BxT](#)" on page 79

**[:SOURCE<hw>]:BB:C2K:FILT:PAR:GAUSS <Gauss>**

Sets the roll-off factor for the Gauss filter type.

**Parameters:**

<Gauss> float  
 Range: 0.15 to 2.5  
 Increment: 0.01  
 \*RST: 0.5

**Example:**

BB:C2K:FILT:PAR:GAUS 0.5  
 Sets B x T to 0.5 for the Gauss filter type.

**Manual operation:** See "[Roll Off Factor or BxT](#)" on page 79

**[:SOURCE<hw>]:BB:C2K:FILT:PAR:LPASS <LPass>**

The command sets the cut-off frequency factor for the Lowpass (ACP Opt.) filter type.

**Parameters:**

<LPass> float  
 Range: 0.05 to 2  
 Increment: 0.01  
 \*RST: 0.5

**Example:**

BB:C2K:FILT:PAR:LPAS 0.5  
 The cut-off frequency factor is set to 0.5.

**Manual operation:** See "[Cutoff Frequency Factor](#)" on page 79

**[:SOURCE<hw>]:BB:C2K:FILT:PAR:LPASSEVM <LPassEvm>**

The command sets the cut-off frequency factor for the Lowpass (EVM Opt.) filter type.

**Parameters:**

<LPassEvm> float  
 Range: 0.05 to 2  
 Increment: 0.01  
 \*RST: 0.5

**Example:** `BB:C2K:FILT:PAR:LPASSEVM 0.5`  
The cut-off frequency factor is set to 0.5.

**Manual operation:** See "[Cutoff Frequency Factor](#)" on page 79

**[[:SOURce<hw>]:BB:C2K:FILT:PAR:PGAuss <PGauss>**

The command sets the roll-off factor for the Pure Gauss filter type.

**Parameters:**

<PGauss> float  
Range: 0.15 to 2.5  
Increment: 0.01  
\*RST: 0.5

**Example:** `BB:C2K:FILT:PAR:GAUS 0.5`  
sets B x T to 0.5 for the Pure Gauss filter type.

**Manual operation:** See "[Roll Off Factor or BxT](#)" on page 79

**[[:SOURce<hw>]:BB:C2K:FILT:PAR:RCOSine <RCosine>**

The command sets the roll-off factor for the Root Cosine filter type.

**Parameters:**

<RCosine> float  
Range: 0.00 to 1.0  
Increment: 0.01  
\*RST: 0.22

**Example:** `BB:C2K:FILT:PAR:RCOS 0.22`  
sets the roll-off factor to 0.22 for filter type Root Cosine.

**Manual operation:** See "[Roll Off Factor or BxT](#)" on page 79

**[[:SOURce<hw>]:BB:C2K:FILT:PAR:SPHase <SPHase>**

The command sets B x T for the Split Phase filter type.

**Parameters:**

<SPHase> float  
Range: 0.15 to 2.5  
Increment: 0.01  
\*RST: 2.00

**Example:** `BB:C2K:FILT:PAR:SPH 0.5`  
sets B x T to 0.5 for the Split Phase filter type.

**Manual operation:** See "[Roll Off Factor or BxT](#)" on page 79

## 4.2.2 Clipping Settings

<code>[ :SOURce&lt;hw&gt;]:BB:C2K:CLIPping:LEVel</code> .....	94
<code>[ :SOURce&lt;hw&gt;]:BB:C2K:CLIPping:MODE</code> .....	94
<code>[ :SOURce&lt;hw&gt;]:BB:C2K:CLIPping:STATe</code> .....	95

---

### `[ :SOURce<hw>]:BB:C2K:CLIPping:LEVel <Level>`

The command sets the limit for level clipping (Clipping). This value indicates at what point the signal is clipped. It is specified as a percentage, relative to the highest level. 100% indicates that clipping does not take place.

Level clipping is activated with the command `[ :SOURce<hw>]:BB:C2K:CLIPping:STATe`

#### Parameters:

<Level>	integer
	Range: 1 PCT to 100
	Increment: 1
	*RST: 100 PCT

#### Example:

```
BB:C2K:CLIP:LEV 80PCT
sets the limit for level clipping to 80% of the maximum level.
BB:C2K:CLIP:STAT ON
activates level clipping.
```

**Manual operation:** See "[Clipping Level](#)" on page 80

---

### `[ :SOURce<hw>]:BB:C2K:CLIPping:MODE <Mode>`

The command sets the method for level clipping (Clipping).

#### Parameters:

<Mode>	VECTor   SCALar
	<b>VECTor</b>
	The reference level is the amplitude $ i+jq $
	<b>SCALar</b>
	The reference level is the absolute maximum of the I and Q values.
	*RST: VECTor

#### Example:

```
BB:C2K:CLIP:MODE SCAL
selects the absolute maximum of all the I and Q values as the
reference level.
BB:C2K:CLIP:LEV 80PCT
sets the limit for level clipping to 80% of this maximum level.
BB:C2K:CLIP:STAT ON
activates level clipping.
```

**Manual operation:** See "[Clipping Mode](#)" on page 80

**[ :SOURce<hw>]:BB:C2K:CLIPping:STATe <State>**

The command activates level clipping (Clipping). The value is defined with the command [ :SOURce<hw>]:BB:C2K:CLIPping:LEVEl, the mode of calculation with the command [ :SOURce<hw>]:BB:C2K:CLIPping:MODE.

**Parameters:**

<State>                   0 | 1 | OFF | ON  
\*RST:                   OFF

**Example:**               BB:C2K:CLIP:STAT ON  
                          activates level clipping.

**Manual operation:**   See "[Clipping State](#)" on page 80

## 4.3 Trigger Settings

**Example: Trigger configuration**

```
SOURce1:BB:C2K:TRIGger:SOURce INTernal
SOURce1:BB:C2K:TRIGger:SEQuence ARETrigger
SOURce1:BB:C2K:STAT ON
SOURce1:BB:C2K:TRIGger:EXECute
SOURce1:BB:C2K:TRIGger:ARM:EXECute
SOURce1:BB:C2K:TRIGger:RMODE?
// stopped
SOURce1:BB:C2K:TRIGger:EXECute
SOURce1:BB:C2K:TRIGger:RMODE?
// run

// SOURce1:BB:C2K:TRIGger:SEQuence SING
// SOURce1:BB:C2K:TRIGger:SLUNit SEQ
// SOURce1:BB:C2K:TRIGger:SLENgth 2

// SOURce1:BB:C2K:TRIGger:SEQuence ARET
// SOURce1:BB:C2K:TRIGger:SOURce EGT1
// SOURce1:BB:C2K:TRIGger:EXTernal:SYNChronize:OUTPut 1
// SOURce1:BB:C2K:TRIGger:EXTernal:INHibit 100
// SOURce1:BB:C2K:TRIGger:EXTernal:DELay 10
```

[ :SOURce<hw>]:BB:C2K[:TRIGger]:SEQuence.....	96
[ :SOURce<hw>]:BB:C2K:TRIGger:SOURce.....	96
[ :SOURce<hw>]:BB:C2K:TRIGger:ARM:EXECute.....	97
[ :SOURce<hw>]:BB:C2K:TRIGger:EXECute.....	97
[ :SOURce<hw>]:BB:C2K:TRIGger:EXTernal:SYNChronize:OUTPut.....	97
[ :SOURce<hw>]:BB:C2K:TRIGger:OBASeband:DELay.....	97
[ :SOURce<hw>]:BB:C2K:TRIGger:OBASeband:INHibit.....	98
[ :SOURce<hw>]:BB:C2K:TRIGger[:EXTernal]:DELay.....	98
[ :SOURce<hw>]:BB:C2K:TRIGger[:EXTernal]:INHibit.....	98

<a href="#">[:SOURce&lt;hw&gt;]:BB:C2K:TRIGger:RMODE?</a> .....	98
<a href="#">[:SOURce&lt;hw&gt;]:BB:C2K:TRIGger:SLENgth</a> .....	99
<a href="#">[:SOURce&lt;hw&gt;]:BB:C2K:TRIGger:SLUNit</a> .....	99

---

### **[:SOURce<hw>]:BB:C2K[:TRIGger]:SEQuence <Sequence>**

Selects the trigger mode:

- AUTO = auto
- RETRigger = retrigger
- AAUTo = armed auto
- ARETRigger = armed retrigger
- SINGle = single

#### **Parameters:**

<Sequence>            AUTO | RETRigger | AAUTo | ARETRigger | SINGle  
 \*RST:                AUTO

**Example:**            See [Example "Trigger configuration"](#) on page 95

**Manual operation:** See ["Trigger Mode"](#) on page 27

---

### **[:SOURce<hw>]:BB:C2K:TRIGger:SOURce <Source>**

Selects the trigger signal source and determines the way the triggering is executed. Provided are:

- Internal triggering by a command (INTernal)
- External trigger signal via one of the local or global connectors
  - EGT1 | EGT2: External global trigger
  - EGC1 | EGC2: External global clock
  - ELTRigger: External local trigger
  - ELCLock: External local clock
- Internal triggering by a signal from the other basebands (INTA | INTB)
- In master-slave mode, the external baseband synchronization signal (BBSY)
- OBASEband | BEXTernal | EXTernal: Setting only  
 Provided only for backward compatibility with other Rohde & Schwarz signal generators.  
 The R&S SMW accepts these values and maps them automatically as follows:  
 EXTernal = EGT1, BEXTernal = EGT2, OBASEband = INTA or INTB  
 (depending on the current baseband)

#### **Parameters:**

<Source>                INTB|INTernal|OBASEband|EGT1|EGT2|EGC1|EGC2|ELTRigger|INTA|ELCLock|BEXTernal|EXTernal | BBSY  
 \*RST:                INTernal

**Example:**            See [Example "Trigger configuration"](#) on page 95

**Options:**             ELTRigger|ELCLock require R&S SMW-B10

BBSY require R&S SMW-B9

**Manual operation:** See ["Trigger Source"](#) on page 28

#### **[:SOURce<hw>]:BB:C2K:TRIGger:ARM:EXECute**

Stops signal generation; a subsequent trigger event restarts signal generation.

**Example:** See [Example "Trigger configuration"](#) on page 95

**Usage:** Event

**Manual operation:** See ["Arm"](#) on page 28

#### **[:SOURce<hw>]:BB:C2K:TRIGger:EXECute**

Executes a trigger.

**Example:** See [Example "Trigger configuration"](#) on page 95

**Usage:** Event

**Manual operation:** See ["Execute Trigger"](#) on page 28

#### **[:SOURce<hw>]:BB:C2K:TRIGger:EXtErnal:SYNChronize:OUTPut <Output>**

Enables signal output synchronous to the trigger event.

**Parameters:**

<Output> 0 | 1 | OFF | ON  
\*RST: 1

**Example:** See [Example "Trigger configuration"](#) on page 95

**Manual operation:** See ["Sync. Output to External Trigger/Sync. Output to Trigger"](#) on page 29

#### **[:SOURce<hw>]:BB:C2K:TRIGger:OBASeband:DELay <Delay>**

Specifies the trigger delay for triggering by the trigger signal from the other baseband.

**Parameters:**

<Delay> float  
Range: 0 to 2147483647  
Increment: 0.01  
\*RST: 0

**Example:**  
SOURce1:BB:C2K:TRIGger:SOURce INTB  
SOURce1:BB:C2K:TRIGger:OBASeband:DELay 100  
SOURce1:BB:C2K:TRIGger:OBASeband:INHibit 10

**Manual operation:** See ["Trigger Delay"](#) on page 30

---

**[ :SOURce<hw>]:BB:C2K:TRIGger:OBASeband:INHibit <Inhibit>**

For triggering via the other path, specifies the duration by which a restart is inhibited.

**Parameters:**

<Inhibit> integer  
 Range: 0 to 67108863  
 \*RST: 0

**Example:** See [\[:SOURce<hw>\]:BB:C2K:TRIGger:OBASeband:DELay](#) on page 97

**Manual operation:** See ["External Trigger Inhibit"](#) on page 30

---

**[ :SOURce<hw>]:BB:C2K:TRIGger[:EXTernal]:DELay <Delay>**

Sets the trigger delay.

**Parameters:**

<Delay> float  
 Range: 0 to 2147483647  
 Increment: 0.01  
 \*RST: 0

**Example:** See [Example "Trigger configuration"](#) on page 95

**Manual operation:** See ["Trigger Delay"](#) on page 30

---

**[ :SOURce<hw>]:BB:C2K:TRIGger[:EXTernal]:INHibit <Inhibit>**

Specifies the duration by which a restart is inhibited.

**Parameters:**

<Inhibit> integer  
 Range: 0 to 21.47\*chipRate  
 \*RST: 0

**Example:** See [Example "Trigger configuration"](#) on page 95

**Manual operation:** See ["External Trigger Inhibit"](#) on page 30

---

**[ :SOURce<hw>]:BB:C2K:TRIGger:RMODE?**

Queries the signal generation status.

**Return values:**

<RMode> STOP | RUN

**Example:** See [Example "Trigger configuration"](#) on page 95

**Usage:** Query only

**Manual operation:** See ["Running/Stopped"](#) on page 28

---

**[[:SOURce<hw>]:BB:C2K:TRIGger:SLENgth <SLength>**

Defines the length of the signal sequence that is output in the `SINGLE` trigger mode.

**Parameters:**

<SLength>                    integer  
                                  Range:        1 to INT\_MAX  
                                  \*RST:        98304

**Example:**                    See [Example "Trigger configuration"](#) on page 95

**Manual operation:**        See ["Trigger Signal Duration"](#) on page 28

---

**[[:SOURce<hw>]:BB:C2K:TRIGger:SLUNit <SIUnit>**

Defines the unit for the entry of the signal sequence length.

**Parameters:**

<SIUnit>                      FRAME | CHIP | SEQUENCE  
                                  \*RST:        SEQUENCE

**Example:**                    See [Example "Trigger configuration"](#) on page 95

**Manual operation:**        See ["Signal Duration Unit"](#) on page 28

---

## 4.4 Marker Settings

**Example: Configure and enable standard marker signals**

```
SOURce1:BB:C2K:TRIGger:OUTPut2:MODE RAT
SOURce1:BB:C2K:TRIGger:OUTPut2:ONTime 20
SOURce1:BB:C2K:TRIGger:OUTPut2:OFFTime 200

SOURce1:BB:C2K:TRIGger:OUTPut3:MODE USER
SOURce1:BB:C2K:TRIGger:OUTPut3:PERiod 100

SOURce1:BB:C2K:TRIGger:OUTPut3:DELay 1000
```

<a href="#">[:SOURce&lt;hw&gt;]:BB:C2K:TRIGger:OUTPut&lt;ch&gt;:MODE</a> .....	99
<a href="#">[:SOURce&lt;hw&gt;]:BB:C2K:TRIGger:OUTPut&lt;ch&gt;:ONTime</a> .....	100
<a href="#">[:SOURce&lt;hw&gt;]:BB:C2K:TRIGger:OUTPut&lt;ch&gt;:OFFTime</a> .....	100
<a href="#">[:SOURce&lt;hw&gt;]:BB:C2K:TRIGger:OUTPut&lt;ch&gt;:PERiod</a> .....	100
<a href="#">[:SOURce&lt;hw&gt;]:BB:C2K:TRIGger:OUTPut&lt;ch&gt;:DELay</a> .....	101

---

**[[:SOURce<hw>]:BB:C2K:TRIGger:OUTPut<ch>:MODE <Mode>**

Defines the signal for the selected marker output.

**Parameters:**

<Mode>                        PCGRoup | RFRame | SCFRame | SFRame | ESECond |  
                                  CSPeriod | RATio | USER

Marker signal that marks:

**PCGRoup**

The start of each power control group (every 1.25 ms).

**RFRame**

Every 20 ms (traffic channel clock).

**SCFRame**

The start of each sync channel frame (every 26.6 ms).

**SFRame**

Every 80 ms (super frame clock).

**ESECond**

Every 2 s (even second mark).

**CSPeriod**

The start of each arbitrary waveform sequence

**RATio**

Off / On times

**USER**

The beginning of every user-defined period

\*RST: PCGRoup

**Example:** See [Example "Configure and enable standard marker signals"](#) on page 99

**Manual operation:** See ["Marker Mode"](#) on page 31

```
[ :SOURce<hw>]:BB:C2K:TRIGger:OUTPut<ch>:ONTime <OnTime>
[:SOURce<hw>]:BB:C2K:TRIGger:OUTPut<ch>:OFFTime <OffTime>
```

Sets the duration during which the marker output is on or off.

\*) If R&S SMW-B9 is installed, the minimum marker duration depends on the sample/symbol rate.

See chapter "Basics on ..." in the R&S SMW user manual.

**Parameters:**

<OffTime>	integer
Range:	1 (R&S SMW-B10) / 1* (R&S SMW-B9) to 16777215
*RST:	1

**Example:** See [Example "Configure and enable standard marker signals"](#) on page 99.

**Manual operation:** See ["Marker Mode"](#) on page 31

```
[ :SOURce<hw>]:BB:C2K:TRIGger:OUTPut<ch>:PERiod <Period>
```

Sets the repetition rate for the signal at the marker outputs.

<sup>\*)</sup> If R&S SMW-B9 is installed, the minimum marker duration depends on the sample/symbol rate.

See chapter "Basics on ..." in the R&S SMW user manual.

**Parameters:**

<Period> integer  
 Range: 1 (R&S SMW-B10) / 1\* (R&S SMW-B9) to max  
 \*RST: 2

**Example:** See [Example "Configure and enable standard marker signals"](#) on page 99

**Manual operation:** See ["Marker Mode"](#) on page 31

**[ :SOURce<hw>]:BB:C2K:TRIGger:OUTPut<ch>:DELay <Delay>**

Defines the delay between the signal on the marker outputs and the start of the signals.

**Parameters:**

<Delay> float  
 Range: 0 to max  
 Increment: 0.001  
 \*RST: 0

**Example:** See [Example "Configure and enable standard marker signals"](#) on page 99

**Manual operation:** See ["Marker x Delay"](#) on page 32

## 4.5 Clock Settings

This section lists the remote control commands, necessary to configure the clock.

<a href="#">[:SOURce&lt;hw&gt;]:BB:C2K:CLOCK:MODE</a> .....	101
<a href="#">[:SOURce&lt;hw&gt;]:BB:C2K:CLOCK:SOURce</a> .....	102

**[ :SOURce<hw>]:BB:C2K:CLOCK:MODE <Mode>**

Sets the type of externally supplied clock.

**Parameters:**

<Mode> CHIP  
 \*RST: CHIP

**Example:** SOURce1:BB:C2K:CLOCK:MODE CHIP

**Options:** R&S SMW-B10

**Manual operation:** See ["Clock Mode"](#) on page 33

---

**[ :SOURce<hw>]:BB:C2K:CLOCK:SOURce <Source>**

Selects the clock source:

- **INTernal**: Internal clock reference
- **ELCLock**: External local clock
- **EXTernal = ELCLock**: Setting only  
Provided for backward compatibility with other Rohde & Schwarz signal generators

**Parameters:**

<Source>                   INTernal|ELCLock|EXTernal  
\*RST:                    INTernal

**Example:**                SOURce1:BB:C2K:CLOCK:SOURce INTernal  
Selects an internal clock reference.

**Options:**                ELCLock requires R&S SMW-B10

**Manual operation:**    See "[Clock Source](#)" on page 33

## 4.6 Predefined Settings

The R&S SMW gives you the opportunity to generate predefined test settings for base station 1. These predefined settings enable the creation of highly complex scenarios for the downlink by presetting the channel table of base station 1. The settings take effect only after execution of command `[ :SOURce<hw>]:BB:C2K:PPARameter:EXECute`.

<code>[ :SOURce&lt;hw&gt;]:BB:C2K:PPARameter:CRESt</code> .....	102
<code>[ :SOURce&lt;hw&gt;]:BB:C2K:PPARameter:EXECute</code> .....	103
<code>[ :SOURce&lt;hw&gt;]:BB:C2K:PPARameter:PCHannel[:STATe]</code> .....	103
<code>[ :SOURce&lt;hw&gt;]:BB:C2K:PPARameter:PICHannel[:STATe]</code> .....	104
<code>[ :SOURce&lt;hw&gt;]:BB:C2K:PPARameter:RCONfiguration</code> .....	104
<code>[ :SOURce&lt;hw&gt;]:BB:C2K:PPARameter:SCHannel[:STATe]</code> .....	104
<code>[ :SOURce&lt;hw&gt;]:BB:C2K:PPARameter:TCHannel:COUNT</code> .....	104
<code>[ :SOURce&lt;hw&gt;]:BB:C2K:PPARameter:TCHannel:DATA:RATE</code> .....	105
<code>[ :SOURce&lt;hw&gt;]:BB:C2K:PPARameter:TCHannel:DCCHannel[:STATe]</code> .....	105
<code>[ :SOURce&lt;hw&gt;]:BB:C2K:PPARameter:TCHannel:FCHannel[:STATe]</code> .....	106
<code>[ :SOURce&lt;hw&gt;]:BB:C2K:PPARameter:TCHannel:FLENGth</code> .....	106
<code>[ :SOURce&lt;hw&gt;]:BB:C2K:PPARameter:TCHannel:SCHannel:COUNT</code> .....	106

---

**[ :SOURce<hw>]:BB:C2K:PPARameter:CRESt <Crest>**

This command selects the desired range for the crest factor of the test scenario. The crest factor of the signal is kept in the desired range by automatically setting appropriate Walsh codes and timing offsets.

The setting takes effect only after execution of command `[ :SOURce<hw>]:BB:C2K:PPARameter:EXECute`.

The setting of command `[ :SOURce<hw> ] :BB:C2K:BSTation<st> :CGRoup<di0> :COFFset<ch> :WCODe` is adjusted according to the selection.

**Parameters:**

&lt;Crest&gt;

MINimum | AVERage | WORSt

**MINimum**

The crest factor is minimized. The Walsh codes are spaced as closely as possible.

**AVERage**

An average crest factor is set. The Walsh codes are distributed uniformly over the code domain.

**WORSt**

The crest factor is set to an unfavorable value (i.e. maximum). The Walsh codes are as wildly spaced as possible.

\*RST: MINimum

**Example:**

BB:C2K:PPAR:CRES WORS

Sets the crest factor to an unfavorable value.

**Manual operation:** See " [Crest Factor](#) " on page 39**[ :SOURce<hw> ] :BB:C2K:PPARameter:EXECute**

This command presets the channel table of base station 1 with the parameters defined by the `PPARameter` commands.

**Example:**

BB:C2K:PPAR:EXEC

configures the signal sequence as defined by the `:BB:C2K:PPARameter` commands.

**Usage:**

Event

**Manual operation:** See " [Accept](#) " on page 41**[ :SOURce<hw> ] :BB:C2K:PPARameter:PCHannel[::STATe] <State>**

The command activates/deactivates the paging channel.

The setting takes effect only after execution of command `[ :SOURce<hw> ] :BB:C2K:PPARameter:EXECute`.

**Parameters:**

&lt;State&gt;

0 | 1 | OFF | ON

\*RST: ON

**Example:**

BB:C2K:PPAR:PCH ON

activates F-PCH.

**Manual operation:** See " [Use Paging Channel \(F-PCH\)](#) " on page 39

---

**[ :SOURce<hw>]:BB:C2K:PPARameter:PICHannel[:STATe] <State>**

The command activates/deactivates the pilot channel.

The setting takes effect only after execution of command `[ :SOURce<hw>]:BB:C2K:PPARameter:EXECute`.

**Parameters:**

<State>            0 | 1 | OFF | ON  
 \*RST:            ON

**Example:**            BB:C2K:PPAR:PICH ON  
 activates F-PICH.

**Manual operation:**    See " [Use Pilot \(F-PICH\)](#) " on page 39

---

**[ :SOURce<hw>]:BB:C2K:PPARameter:RCONfiguration <RConfiguration>**

Selects the radio configuration for the traffic channel.

The setting takes effect only after execution of command `[ :SOURce<hw>]:BB:C2K:PPARameter:EXECute`.

**Parameters:**

<RConfiguration>    1 | 2 | 3 | 4 | 5  
 \*RST:            1

**Example:**            BB:C2K:PPAR:RCON 1  
 selects radio configuration 1.

**Manual operation:**    See " [Radio Configuration](#) " on page 39

---

**[ :SOURce<hw>]:BB:C2K:PPARameter:SCHannel[:STATe] <State>**

Activates/deactivates the F-SYNC.

The setting takes effect only after execution of command `[ :SOURce<hw>]:BB:C2K:PPARameter:EXECute`.

**Parameters:**

<State>            0 | 1 | OFF | ON  
 \*RST:            1

**Example:**            BB:C2K:PPAR:SCH ON  
 activates the F-SYNC.

**Manual operation:**    See " [Use Sync \(F-Sync\)](#) " on page 39

---

**[ :SOURce<hw>]:BB:C2K:PPARameter:TCHannel:COUNT <Count>**

This command sets the number of activated traffic channels.

The setting takes effect only after execution of command `[ :SOURce<hw>]:BB:C2K:PPARameter:EXECute`.

**Parameters:**

<Count> integer  
 Range: 0 to 8  
 \*RST: 1

**Example:**

BB:C2K:PPAR:TCH:COUN 2  
 the predefined signal contains 2 traffic channels.

**Manual operation:** See " [Number of Traffic Channels](#) " on page 40

**[ :SOURce<hw>]:BB:C2K:PPARameter:TCHannel:DATA:RATE <Rate>**

This command sets the data rate of F-FCH and F-SCH. The set value is specific for the selected radio configuration.

The setting takes effect only after execution of command [\[ :SOURce<hw>\]:BB:C2K:PPARameter:EXECute](#). It is specific for the selected radio configuration.

The value range depends on the frame length. If the frame length is changed so that the set data rate becomes invalid, the next permissible value is automatically set.

The data rate affects the Walsh code (spreading factor) that are possible within a channel. If a data rate is changed so that the selected Walsh code becomes invalid, the next permissible value is automatically set.

**Parameters:**

<Rate> DR1K2 | DR1K3 | DR1K5 | DR1K8 | DR2K4 | DR2K7 | DR3K6 |  
 DR4K8 | DR7K2 | DR9K6 | DR14K4 | DR19K2 | DR28K8 |  
 DR38K4 | DR57K6 | DR76K8 | DR115K2 | DR153K6 |  
 DR230K4 | DR259K2 | DR307K2 | DR460K8 | DR518K4 |  
 DR614K4 | DR1036K8 | NUSed  
 \*RST: DR1K2

**Example:**

BB:C2K:PPAR:TCH:DATA:RATE D240K  
 sets the data rate of F-FCH and F-SCH to 240 ksps.

**Manual operation:** See " [Data Rate](#) " on page 41

**[ :SOURce<hw>]:BB:C2K:PPARameter:TCHannel:DCCHannel[:STATE] <State>**

Activates/deactivates the dedicated control channel. F-DCCH cannot be selected for RC1 and RC2.

The setting takes effect only after execution of command [\[ :SOURce<hw>\]:BB:C2K:PPARameter:EXECute](#). It is specific for the selected radio configuration.

**Parameters:**

<State> 0 | 1 | OFF | ON  
 \*RST: 1

**Example:**

BB:C2K:PPAR:TCH:DCCH ON  
 Activates F-DCCH.

**Manual operation:** See " [Use Dedicated Control \(F-DCCH\)](#) " on page 40

---

**[ :SOURce<hw>]:BB:C2K:PPARameter:TCHannel:FCHannel[:STATe] <State>**

Activates/deactivates the fundamental channel.

The setting takes effect only after execution of command `[ :SOURce<hw>]:BB:C2K:PPARameter:EXECute`. It is specific for the selected radio configuration.

**Parameters:**

<State>            0 | 1 | OFF | ON  
 \*RST:            1

**Example:**

BB:C2K:PPAR:TCH:FCH ON  
 activates F-FCH.

**Manual operation:** See " [Use Fundamental \(F-FCH\)](#) " on page 40

---

**[ :SOURce<hw>]:BB:C2K:PPARameter:TCHannel:FLENGth <FLength>**

The command activates/deactivates the fundamental channel. The set value is specific for the selected radio configuration.

The setting takes effect only after execution of command `[ :SOURce<hw>]:BB:C2K:PPARameter:EXECute`. It is specific for the selected radio configuration.

The frame length affects the data rates that are possible within a channel. Changing the frame length can lead to a change of data rate and this in turn can bring about a change of Walsh code.

**Parameters:**

<FLength>        20 | 40 | 80  
 \*RST:            20 ms

**Example:**

BB:C2K:PPAR:TCH:FLEN 20 ms  
 Sets the frame length of the code channels to 20 ms.

**Manual operation:** See " [Frame Length](#) " on page 41

---

**[ :SOURce<hw>]:BB:C2K:PPARameter:TCHannel:SCHannel:COUNT <Count>**

Sets the number of supplemental channels. The maximum number of supplemental channels depends on the selected radio configuration.

The setting takes effect only after execution of command `[ :SOURce<hw>]:BB:C2K:PPARameter:EXECute`. It is specific for the selected radio configuration.

**Parameters:**

<Count>            integer  
 Range:            0 to 7  
 \*RST:            1

**Example:**

BB:C2K:PPAR:TCH:SCH:COUN 2  
 selects two F-SCHs.

**Manual operation:** See " [Number of Supplemental \(F-SCH\)](#) " on page 40

## 4.7 Base Stations Settings

The `SOURce:BB:C2K:BSTation` system contains commands for setting base stations.

The commands of this system only take effect if the CDMA2000 standard is activated, the DOWN transmission direction is selected and the particular base station is enabled:

- `SOURce:BB:C2K:STATe ON`
- `SOURce:BB:C2K:LINK DOWN`
- `SOURce:BB:C2K:BSTation2:STATe ON`

### Suffixes



The channel table for the base station is configured from 14 special channels and up to eight traffic channels. Each traffic channel consists of four to eight code channels. The type and number of code channels depends on the radio configuration chosen for the traffic channel.

The individual channels are selected in SCPI via the suffixes to keywords `CGRoup` and `COFFset`.

The special channels have the suffix 0 to `CGRoup` and 1 to 14 to `COFFset` corresponding to the channel index 0 to 1 to 0 to 14 in the channel table.

The code channels of a traffic channel are addressed by means of suffixes 1 to 8 for the traffic channel and 1 to 8 to `COFFset` for the sub channels of the selected traffic channel. Thus `CGRoup2:COFFset1` is the code channel F-FCH of the traffic channel 2 and equates to the channel index 2 to 1 in the channel table.

**Table 4-1: Structure of the traffic channel for different radio configurations.**

	Radio Configuration 1, 2	Radio Configuration 3, 4, 5
1-1 ( <code>CGRoup1:COFFset1</code> )	F-FCH	F-FCH
1-2 ( <code>CGRoup1:COFFset2</code> )	F-SCH1	F-SCH1
1-3 ( <code>CGRoup1:COFFset3</code> )	F-SCH2	F-SCH2
1-4 ( <code>CGRoup1:COFFset4</code> )	F-SCH3	F-DCCH
1-5 ( <code>CGRoup1:COFFset5</code> )	F-SCH4	-
1-6 ( <code>CGRoup1:COFFset6</code> )	F-SCH5	-
1-7 ( <code>CGRoup1:COFFset7</code> )	F-SCH6	-
1-8 ( <code>CGRoup1:COFFset8</code> )	F-SCH7	-

Regardless of the radio configuration, in all traffic channels the `COFFset1` corresponds to the F-FCH, and the `COFFset2` and `COFFset3` correspond to the F-SCH1 and F-SCH2, respectively. In radio configurations 1 and 2 the `COFFset4` corresponds to the F-SCH3, and in radio configurations 3, 4, 5 to the F-DCCH. `COFFset5`,

COFFset6,COFFset7 and COFFset8 exist only in radio configurations 1 and 2, where they correspond to the F-SCH4 to F-SCH7.



For the code channels of a traffic channels, the settings of the channel table parameters are specific for the selected radio configuration. I.e. a complete set of settings exists for each of the five possible radio configurations.

See also "Common suffixes" on page 83.

[SOURce<hw>]:BB:C2K:BSTation:PRESet.....	109
[SOURce<hw>]:BB:C2K:BSTation:SYNC:CNUMber.....	109
[SOURce<hw>]:BB:C2K:BSTation:SYNC:LCSTate.....	109
[SOURce<hw>]:BB:C2K:BSTation:SYNC:MPRev.....	110
[SOURce<hw>]:BB:C2K:BSTation:SYNC:NID.....	110
[SOURce<hw>]:BB:C2K:BSTation:SYNC:PREV.....	110
[SOURce<hw>]:BB:C2K:BSTation:SYNC:SID.....	111
[SOURce<hw>]:BB:C2K:BSTation:SYNC:STIME.....	111
[SOURce<hw>]:BB:C2K:BSTation<st>:CGRoup<di0>:COFFset<ch>:CCODing: BINTerleaver?.....	112
[SOURce<hw>]:BB:C2K:BSTation<st>:CGRoup<di0>:COFFset<ch>:CCODing:BITFrame?..	112
[SOURce<hw>]:BB:C2K:BSTation<st>:CGRoup<di0>:COFFset<ch>:CCODing:CRc?.....	113
[SOURce<hw>]:BB:C2K:BSTation<st>:CGRoup<di0>:COFFset<ch>:CCODing:DATA: RATE?.....	113
[SOURce<hw>]:BB:C2K:BSTation<st>:CGRoup<di0>:COFFset<ch>:CCODing:MODE.....	114
[SOURce<hw>]:BB:C2K:BSTation<st>:CGRoup<di0>:COFFset<ch>:CCODing: SPUNcture?.....	114
[SOURce<hw>]:BB:C2K:BSTation<st>:CGRoup<di0>:COFFset<ch>:CCODing: SREPetition?.....	115
[SOURce<hw>]:BB:C2K:BSTation<st>:CGRoup<di0>:COFFset<ch>:CCODing:TYPE.....	115
[SOURce<hw>]:BB:C2K:BSTation<st>:CGRoup<di0>:COFFset<ch>:DATA.....	116
[SOURce<hw>]:BB:C2K:BSTation<st>:CGRoup<di0>:COFFset<ch>:DATA:DSElect.....	117
[SOURce<hw>]:BB:C2K:BSTation<st>:CGRoup<di0>:COFFset<ch>:DATA:PATtern.....	117
[SOURce<hw>]:BB:C2K:BSTation<st>:CGRoup<di0>:COFFset<ch>:DATA:RATE.....	118
[SOURce<hw>]:BB:C2K:BSTation<st>:CGRoup<di0>:COFFset<ch>:FLENgth.....	118
[SOURce<hw>]:BB:C2K:BSTation<st>:CGRoup<di0>:COFFset<ch>:LCMask.....	119
[SOURce<hw>]:BB:C2K:BSTation<st>:CGRoup<di0>:COFFset<ch>:POWER.....	119
[SOURce<hw>]:BB:C2K:BSTation<st>:CGRoup<di0>:COFFset<ch>:QWCode:STATe.....	120
[SOURce<hw>]:BB:C2K:BSTation<st>:CGRoup<di0>:COFFset<ch>:STATe.....	120
[SOURce<hw>]:BB:C2K:BSTation<st>:CGRoup<di0>:COFFset<ch>:TPC:DATA.....	120
[SOURce<hw>]:BB:C2K:BSTation<st>:CGRoup<di0>:COFFset<ch>:TPC:DATA:DSElect...	121
[SOURce<hw>]:BB:C2K:BSTation<st>:CGRoup<di0>:COFFset<ch>:TPC:DATA:PATtern....	122
[SOURce<hw>]:BB:C2K:BSTation<st>:CGRoup<di0>:COFFset<ch>:TPC:MISuse.....	122
[SOURce<hw>]:BB:C2K:BSTation<st>:CGRoup<di0>:COFFset<ch>:TPC:PSTep.....	123
[SOURce<hw>]:BB:C2K:BSTation<st>:CGRoup<di0>:COFFset<ch>:TPC:READ.....	124
[SOURce<hw>]:BB:C2K:BSTation<st>:CGRoup<di0>:COFFset<ch>:TYPE?.....	124
[SOURce<hw>]:BB:C2K:BSTation<st>:CGRoup<di0>:COFFset<ch>:WCODE.....	125
[SOURce<hw>]:BB:C2K:BSTation<st>:CGRoup<di0>:COFFset<ch>:WLENgth?.....	125
[SOURce<hw>]:BB:C2K:BSTation<st>:CGRoup<di0>:RCONfiguration.....	126
[SOURce<hw>]:BB:C2K:BSTation<st>:DCONflict:MODE.....	126
[SOURce<hw>]:BB:C2K:BSTation<st>:DCONflict:RESolve.....	127

<code>[:SOURce&lt;hw&gt;]:BB:C2K:BSTation&lt;st&gt;:DCONflict[:STATe]?</code> .....	127
<code>[:SOURce&lt;hw&gt;]:BB:C2K:BSTation&lt;st&gt;:PDCHannel:PINTerval</code> .....	127
<code>[:SOURce&lt;hw&gt;]:BB:C2K:BSTation&lt;st&gt;:PDCHannel:PSETup</code> .....	128
<code>[:SOURce&lt;hw&gt;]:BB:C2K:BSTation&lt;st&gt;:PDCHannel:SUBPacket&lt;di&gt;:ID</code> .....	128
<code>[:SOURce&lt;hw&gt;]:BB:C2K:BSTation&lt;st&gt;:PDCHannel:SUBPacket&lt;di&gt;:PARAmeters</code> .....	128
<code>[:SOURce&lt;hw&gt;]:BB:C2K:BSTation&lt;st&gt;:PDCHannel:SUBPacket&lt;di&gt;:STATe</code> .....	133
<code>[:SOURce&lt;hw&gt;]:BB:C2K:BSTation&lt;st&gt;:PDCHannel:SUBPacket&lt;di&gt;:TOFFset</code> .....	133
<code>[:SOURce&lt;hw&gt;]:BB:C2K:BSTation&lt;st&gt;:PDCHannel:SUBPacket&lt;di&gt;:WCODes?</code> .....	134
<code>[:SOURce&lt;hw&gt;]:BB:C2K:BSTation&lt;st&gt;:PDCHannel:WINDex</code> .....	134
<code>[:SOURce&lt;hw&gt;]:BB:C2K:BSTation&lt;st&gt;:PNOFFset</code> .....	135
<code>[:SOURce&lt;hw&gt;]:BB:C2K:BSTation&lt;st&gt;:QWSet</code> .....	135
<code>[:SOURce&lt;hw&gt;]:BB:C2K:BSTation&lt;st&gt;:STATe</code> .....	135
<code>[:SOURce&lt;hw&gt;]:BB:C2K:BSTation&lt;st&gt;:TDELay</code> .....	135
<code>[:SOURce&lt;hw&gt;]:BB:C2K:BSTation&lt;st&gt;:TDIVersity</code> .....	136
<code>[:SOURce&lt;hw&gt;]:BB:C2K:BSTation&lt;st&gt;:TDIVersity:MODE</code> .....	136

---

### `[:SOURce<hw>]:BB:C2K:BSTation:PRESet`

A standardized default for all the base stations (\*RST values specified for the commands).

See "[Reset All Base Stations](#)" on page 35 for an overview.

**Example:** `SOURce1:BB:C2K:BSTation:PRESet`

**Usage:** Event

**Manual operation:** See "[Reset All Base Stations](#)" on page 35

---

### `[:SOURce<hw>]:BB:C2K:BSTation:SYNC:CNUMber <CNumber>`

Sets the CDMA Channel Number which corresponds to the RF.

**Parameters:**

<code>&lt;CNumber&gt;</code>	integer
Range:	0 to 2047
*RST:	387

**Example:** `BB:C2K:BST:SYNC:CNUM 400`  
sets the channel number

**Manual operation:** See "[CDMA Channel Number - More Params BS](#)" on page 64

---

### `[:SOURce<hw>]:BB:C2K:BSTation:SYNC:LCState <LcState>`

Defines the long code state in hexadecimal format.

**Parameters:**

<code>&lt;LcState&gt;</code>	42 bit
Range:	0 to 3FFFFFFFFF
*RST:	0

**Example:** `BB:C2K:BST:SYNC:LCST #H0001F3A002E1`  
sets the Long Code state parameter.

**Manual operation:** See "[LC State \(hex\) - More Params BS](#)" on page 64

**[[:SOURce<hw>]:BB:C2K:BSTation:SYNC:MPRev <MPrev>**

Sets the Minimum Protocol Revision Level.

The base station sets this field to prevent mobile stations which cannot be supported by the base station from accessing the CDMA system.

**Parameters:**

<MPrev>                    2 | 8  
Range:                    2 to 8  
\*RST:                    2

**Example:** `BB:C2K:BST:SYNC:MPR 3`  
Sets the MIN\_P\_REV parameter

**Manual operation:** See "[MIN\\_P\\_REV - More Params BS](#)" on page 64

**[[:SOURce<hw>]:BB:C2K:BSTation:SYNC:NID <Nid>**

Sets the Network Identification.

The NID serves as a sub-identifier of a CDMA system as defined by the owner of the SID.

**Parameters:**

<Nid>                    integer  
Range:                    0 to 65535  
\*RST:                    1

**Example:** `BB:C2K:BST:SYNC:NID 5`  
sets the network identification parameter

**Manual operation:** See "[NID - More Params BS](#)" on page 65

**[[:SOURce<hw>]:BB:C2K:BSTation:SYNC:PREV <Prev>**

Sets the Protocol Revision Level, i.e. specifies the CDMA2000 system release number.

The table below gives the cross-reference between the P\_REV values and the CDMA2000 Releases.

P_REV	CDMA2000 Release
1	Korean PCS(Band Class4), USPCS(Band Class1)
2	IS-95
3	TBS74
4	IS-95A

P_REV	CDMA2000 Release
5	IS-95B
6	IS2000 Release 0
7	IS2000 Release A
8	IS2000 Release B

**Parameters:**

<Prev> integer  
 Range: 1 to 8  
 \*RST: 6

**Example:** BB:C2K:BST:SYNC:PREV 4  
 sets the P\_REV parameter

**Manual operation:** See "[P\\_REV - More Params BS](#)" on page 64

**[:SOURCE<hw>]:BB:C2K:BSTation:SYNC:SID <Sid>**

Displays the System Identification.

The base station sets the system identification number.

**Parameters:**

<Sid> integer  
 Range: 0 to 32767  
 \*RST: 10

**Example:** BB:C2K:BST:SYNC:SID 10  
 sets the system identification parameter

**Manual operation:** See "[SID - More Params BS](#)" on page 65

**[:SOURCE<hw>]:BB:C2K:BSTation:SYNC:STIME <SystTime>**

Displays the system time.

**Parameters:**

<SystTime> integer  
 Range: 0 to 68719476735  
 \*RST: 0

**Example:** BB:C2K:BST:SYNC:STIM 4  
 sets the system time.

**Manual operation:** See "[System Time - More Params BS](#)" on page 64

---

**[ :SOURce<hw>]:BB:C2K:BSTation<st>:CGRoup<di0>:COFFset<ch>:CCODing:  
BINTerleaver?**

The command queries the number of symbols per block which are processed by the interleaver. This value is only available for channel coding modes "Complete" and "Without Interleaving"

(SOURce:BB:C2K:BST<n>:CGRoup<n>:COFFset<n>:CCODing:MODE COMP | NOIN).

For the traffic channels, this value is specific for the selected radio configuration.

**Return values:**

<BInterleaver> 48 | 96 | 128 | 144 | 192 | 288 | 384 | 576 | 768 | 1152 | 1536 |  
2304 | 3072 | 4608 | 6144 | 9216 | 12288 | 18432 | 36864 |  
NONE

**Example:**

BB:C2K:BST:CGR3:COFF1:CCOD:MODE COMP  
selects channel coding mode "Complete" for F-FCH of the third  
traffic channel.

BB:C2K:BST:CGR3:COFF1:CCOD:BINT?  
queries the number of symbols per block which are processed  
by the interleaver.

Response: 384

384 symbols per block are processed.

**Usage:** Query only

**Manual operation:** See "[Block Interleaver](#)" on page 63

---

**[ :SOURce<hw>]:BB:C2K:BSTation<st>:CGRoup<di0>:COFFset<ch>:CCODing:  
BITFrame?**

Queries the number of input bits per frame for the channel coder. This value is only available for channel coding modes "Complete" and "Without Interleaving"

(SOURce:BB:C2K:BST<n>:CGRoup<n>:COFFset<n>:CCODing:MODE COMP | NOIN).

For the traffic channels, this value is specific for the selected radio configuration.

**Return values:**

<BitFrame> integer  
Range: 16 to 20712  
\*RST: 16

**Example:**

BB:C2K:BST:CGR3:COFF1:CCOD:MODE COMP  
selects channel coding mode "Complete" for F-FCH of the third  
traffic channel.

BB:C2K:BST:CGR3:COFF1:CCOD:BITF?  
queries the number of input bits per frame.

Response: 16

16 bits per frame.

**Usage:** Query only

**Manual operation:** See "Source Bits / Frame" on page 62

---

**[ :SOURce<hw>]:BB:C2K:BSTation<st>:CGRoup<di0>:COFFset<ch>:CCODing:  
CRC?**

Queries the CRC (cyclic redundancy code) type (length). This value is only available for channel coding modes "Complete" and "Without Interleaving"

(SOURce:BB:C2K:BST<n>:CGRoup<n>:COFFset<n>:CCODing:MODE COMP | NOIN).

For the traffic channels, this value is specific for the selected radio configuration.

**Return values:**

<Crc> integer  
Range: 0 to 16  
\*RST: 0

**Example:**

BB:C2K:BST:CGR1:COFF1:CCOD:MODE COMP  
selects channel coding mode "Complete" for F-FCH of the first traffic channel.

BB:C2K:BST:CGR1:COFF1:CCOD:CRC?

queries the CRC type.

Response: 6

CRC type 6 is used.

**Usage:** Query only

---

**[ :SOURce<hw>]:BB:C2K:BSTation<st>:CGRoup<di0>:COFFset<ch>:CCODing:  
DATA:RATE?**

The command queries the effective data rate in Hz. This value is only available for channel coding modes "Off" and "Interleaving Only"

(SOURce:BB:C2K:BST<n>:CGRoup<n>:COFFset<n>:CCODing:MODE OFF | OINT).

When channel coding is switched off, the effective data rate differs from the data rate set in the channel table. The data are read out with the effective rate.

For the traffic channels, this value is specific for the selected radio configuration.

**Return values:**

<Rate> float

**Example:**

BB:C2K:BST:CGR3:COFF1:CCOD:MODE OINT

selects channel coding mode "Interleaving Only" for F-FCH of the third traffic channel.

BB:C2K:BST:CGR3:COFF1:CCOD:DATA:RATE?

queries the effective data rate.

Response: 19200

the effective data is 19.2 kbps.

**Usage:** Query only

**Manual operation:** See ["Data Rate"](#) on page 63

---

**[:SOURce<hw>]:BB:C2K:BSTation<st>:CGRoup<di0>:COFFset<ch>:CCODing:  
MODE <Mode>**

Selects channel coding mode. For the traffic channels, this value is specific for the selected radio configuration.

**Parameters:**

<Mode>

OFF | COMPlete | NOINterleaving | OINTerleaving

**OFF**

Channel coding is deactivated.

**COMPlete**

The complete channel coding is performed. The channel coding procedure can slightly vary depending on channel type, frame length and data rate.

**OINTerleaving**

Except for the block interleaver, the whole channel coding procedure is carried out. In this mode, the frame structure and the convolutional coder of a receiver can be tested.

**NOINterleaving**

In this mode, only block interleaver is used for coding. This allows the deinterleaver in the receiver to be tested independently of the remaining (de-)coding process.

\*RST: COMPlete

**Example:**

BB:C2K:BST:CGR3:COFF1:CCOD:MODE OFF

Deactivates channel coding for F-FCH of the third traffic channel.

**Manual operation:** See ["Coding Mode"](#) on page 61

---

**[:SOURce<hw>]:BB:C2K:BSTation<st>:CGRoup<di0>:COFFset<ch>:CCODing:  
SPUNcture?**

The command queries the symbol puncture rate. This value is only available for channel coding modes "Complete" and "Without Interleaving"

(SOURce:BB:C2K:BST<n>:CGRoup<n>:COFFset<n>:CCODing:MODE COMP | NOIN).

For the traffic channels, this value is specific for the selected radio configuration.

**Return values:**

<SPuncture>

8OF24 | 1OF5 | 1OF9 | 4OF12 | 2OF18 | 2OF6 | T2OF18 |  
T4OF12 | NONE

**xOFy**

a symbol puncture rate of x out of y is used

**TxOFy**

a symbol puncture rate of x out of y Turbo is used

**Example:** BB:C2K:BST:CGR3:COFF1:CCOD:MODE COMP  
selects channel coding mode "Complete" for F-FCH of the third traffic channel.  
BB:C2K:BST:CGR3:COFF1:CCOD:SPUN?  
queries the symbol puncture rate.  
Response: 80F24  
a symbol puncture rate of 8 out of 24 is used.

**Usage:** Query only

**Manual operation:** See "[Symbol Puncture](#)" on page 62

**[:SOURCE<hw>]:BB:C2K:BSTation<st>:CGRoup<di0>:COFFset<ch>:CCODing:  
SREPetition?**

Queries symbol repetition rate. This value is only available for channel coding modes "Complete" and "Without Interleaving"

(SOURCE:BB:C2K:BST<n>:CGRoup<n>:COFFset<n>:CCODing:MODE COMP | NOIN).

For the traffic channels, this value is specific for the selected radio configuration.

**Return values:**

<SRepetition> integer  
Range: 1 to 16  
\*RST: 0

**Example:** BB:C2K:BST:CGR3:COFF1:CCOD:MODE COMP  
selects channel coding mode "Complete" for F-FCH of the third traffic channel.  
BB:C2K:BST:CGR3:COFF1:CCOD:SREP?  
queries symbol repetition rate.  
Response: 8  
a symbol repetition rate of 8 is used.

**Usage:** Query only

**Manual operation:** See "[Symbol Repetition](#)" on page 62

**[:SOURCE<hw>]:BB:C2K:BSTation<st>:CGRoup<di0>:COFFset<ch>:CCODing:  
TYPE <Type>**

The command sets the channel coding type.

This value is only available for channel coding modes "Complete" and "Without Interleaving" (SOURCE:BB:C2K:BST<n>:CGRoup<n>:COFFset<n>:CCODing:MODE COMP | NOIN). For the traffic channels, this value is specific for the selected radio configuration.

**Parameters:**

<Type> CON2 | CON3 | CON4 | CON6 | TUR2 | TUR3 | TUR4 | TUR5 |  
OFF | DEFault

**NONE**

No error protection

**TURx**

Turbo Coder of rate 1/x in accordance with the CDMA specifications.

**CONx**

Convolution Coder of rate 1/x with generator polynomials defined by CDMA.

\*RST: Channel-specific

**Example:**

BB:C2K:BST:CGR3:COFF2:CCOD:MODE COMP

selects channel coding mode "Complete" for F-SCH1 of the third traffic channel.

BB:C2K:BST:CGR3:COFF2:CCOD:TYPE TURB4

selects turbo coder with a rate of 1/4 for F-SCH1 of the third traffic channel.

**Manual operation:** See "Coder Type" on page 61

---

**[:SOURCE<hw>]:BB:C2K:BSTation<st>:CGRoup<di0>:COFFset<ch>:DATA**  
<Data>

The command selects the data source for the specified channel.

For the traffic channels, this value is specific for the selected radio configuration.

The data source for the power control bits is selected with the command :BB:C2K:BST<n>:CGRoup<n>:COFFset<n>:TPC:DATA.

**Parameters:**

<Data>

ZERO | ONE | PATtern | PN9 | PN11 | PN15 | PN16 | PN20 | PN21 | PN23 | DLISt

**PNxx**

The pseudo-random sequence generator is used as the data source. Different random sequence lengths can be selected.

**DLISt**

A data list is used. The data list is selected with the command :BB:C2K:BST<n>:CGRoup<n>:COFFset<n>:DATA:DSEL.

**ZERO | ONE**

Internal 0 and 1 data is used.

**PATtern**

Internal data is used. The bit pattern for the data is defined by the command :BB:C2K:BST:CGRoup:COFFset:DATA:PATT.

\*RST: F-PICH; F-TDPICH; F-APICH; F-ATDPICH: ALL0;  
all other channels: PN9

**Example:** `BB:C2K:BST2:CGR3:COFF1:DATA PATT`  
 Selects as the data source for the F-FCH of the third traffic channel of base station 2, the bit pattern defined with the following command:  
`BB:C2K:BST2:CGR3:COFF1:DATA:PATT #H3F,8`  
 Defines the bit pattern.

**Manual operation:** See "Data" on page 50

**[:SOURCE<hw>]:BB:C2K:BSTation<st>:CGRoup<di0>:COFFset<ch>:DATA:  
 DSElect <DSelect>**

The command selects the data list for the DLIS data source selection.

The lists are stored as files with the fixed file extensions `*.dm_iqd` in a directory of the user's choice. The directory applicable to the following commands is defined with the command `MMEMoRY:CDIR`. To access the files in this directory, you only have to give the file name, without the path and the file extension.

For the traffic channels, this value is specific for the selected radio configuration.

**Parameters:**

<DSelect>                    string

**Example:**

`BB:C2K:BST2:CGR3:COFF1:DATA DLIS`  
 selects the Data Lists data source for the F-FCH of the third traffic channel of basestation2.  
`MMEMoRY:CDIR "/var/user/temp/Lists"`  
 selects the directory for the data lists.  
`BB:C2K:BST2:CGR3:COFF1:DATA:DLIS "cdma_list1"`  
 selects file "cdma\_list1" as the data source. This file must be in specified directory and it must have the file extension `*.dm_iqd`.

**Manual operation:** See "Data" on page 50

**[:SOURCE<hw>]:BB:C2K:BSTation<st>:CGRoup<di0>:COFFset<ch>:DATA:  
 PATtern <Pattern>, <BitCount>**

Sets the bit pattern for the PATtern selection. The first parameter determines the bit pattern (choice of hexadecimal, octal or binary notation), the second specifies the number of bits to use.

For the traffic channels, this value is specific for the selected radio configuration.

**Parameters:**

<Pattern>                    numeric  
                               \*RST:        #H0

<BitCount>                  integer  
                               Range:        1 to 64  
                               \*RST:        1

**Example:** BB:C2K:BST2:CGR3:COFF1:DATA:PATT #H800FE038, 30  
defines the bit pattern.

**Manual operation:** See "Data" on page 50

**[:SOURCE<hw>]:BB:C2K:BSTation<st>:CGRoup<di0>:COFFset<ch>:DATA:RATE  
<Rate>**

The command sets the data rate for the specified channel. The value range depends on the channel type, the selected radio configuration and the frame length. Parameter NUSed is returned for channel 0-1 to 0-4.

For the traffic channels, this value is specific for the selected radio configuration.

The value range depends on the frame length. If the frame length is changed so that the set data rate becomes invalid, the next permissible value is automatically set.

The data rate affects the Walsh code (spreading factor) that are possible within a channel. If a data rate is changed so that the selected Walsh code becomes invalid, the next permissible value is automatically set.

**Parameters:**

<Rate> DR1K2 | DR1K3 | DR1K5 | DR1K8 | DR2K4 | DR2K7 | DR3K6 |  
DR4K8 | DR7K2 | DR9K6 | DR14K4 | DR19K2 | DR28K8 |  
DR38K4 | DR57K6 | DR76K8 | DR115K2 | DR153K6 |  
DR230K4 | DR307K2 | NUSed  
\*RST: Channel-specific

**Example:** BB:C2K:BST2:CGR3:COFF1:DATA:RATE DR4K8  
sets a data rate of 4.8 kbps for F-FCH of the third traffic channel of base station 2.

**Manual operation:** See "Data Rate" on page 49

**[:SOURCE<hw>]:BB:C2K:BSTation<st>:CGRoup<di0>:COFFset<ch>:FLENgth  
<FLength>**

The command sets the frame length of the selected channel. The value range is channel specific.

For the traffic channels, this value is specific for the selected radio configuration.

The value range of the frame length depends on the channel type and the selected radio configuration.

The frame length affects the data rates that are possible within a channel. Changing the frame length can lead to a change of data rate and this in turn can bring about a change of Walsh code.

**Parameters:**

<FLength> 5 | 10 | 20 | 26.6 | 40 | 80 | 160 | NUSed

**26 ms**

Frame length of 26.6. Also all inputs 26.6 ms and 26.7 ms are allowed.

\*RST: F-SYNC: 26.6; F\_BCH: 40 ms; F\_CACH: 5 ms; all other channels: 20 ms

**Example:**

BB:C2K:BST:CGR3:COFF4:FLEN 5 ms

Sets the frame length of sub channel 3 ms to 4 ms to 5 ms.

**Manual operation:** See "[Frame Length](#)" on page 49

**[ :SOURce<hw>]:BB:C2K:BSTation<st>:CGRoup<di0>:COFFset<ch>:LCMask  
<LcMask>**

The command sets the mask of the Long Code Generator of the base station.

For the traffic channels, this value is specific for the selected radio configuration.

The LC Mask is the same for all sub channels of a traffic channel. If the mask is modified for one of the sub channels, the new value is then automatically used by all other subchannels of this traffic channel.

**Parameters:**

<LcMask> integer

Range: #H0 to #H3FF FFFF FFFF

\*RST: #H0

**Example:**

BB:C2K:BST1:CGR2:COFF1:LCM #H55

Sets the Long Code Mask to #H55.

**Manual operation:** See "[LC Mask \(hex\) - More Parameters BS](#)" on page 57

**[ :SOURce<hw>]:BB:C2K:BSTation<st>:CGRoup<di0>:COFFset<ch>:POWER  
<Power>**

Sets the channel power relative to the powers of the other channels. This setting also determines the starting power of the channel for Misuse Output Power Control.

With the command [ :SOURce<hw>]:BB:C2K:POWER:ADJust, the power of all the activated channels is adapted so that the total power corresponds to 0 dB. This does not change the power ratio among the individual channels.

For the traffic channels, this value is specific for the selected radio configuration.

**Parameters:**

<Power> float

Range: -80 to depends on channel

Increment: 0.01

\*RST: 0

**Example:** `BB:C2K:BST2:CGR3:COFF4:POW -10dB`  
Sets the channel power of sub channel 3 to 4 of base station 2 dB to -10 dB relative to the power of the other channels.

**Manual operation:** See ["Power"](#) on page 50

**[:SOURCE<hw>]:BB:C2K:BSTation<st>:CGRoup<di0>:COFFset<ch>:QWCode:STATE <State>**

Activates/deactivates the use of the quasi orthogonal Walsh codes for the channel.

The quasi orthogonal Walsh Code set is selected for all channels of the base station with command `[:SOURCE<hw>]:BB:C2K:BSTation<st>:QWSet`.

For the traffic channels, this value is specific for the selected radio configuration. It is only available for radio configuration 3 and higher.

**Parameters:**

<State> 0 | 1 | OFF | ON

\*RST: 0

**Example:** `BB:C2K:BST1:QWS 3`  
selects quasi orthogonal Walsh code set 3 for base station 1.  
`BB:C2K:BST1:CGR3:COFF4:QWC:STAT ON`  
activates the use of the quasi orthogonal Walsh code for sub channel 3-4.

**Manual operation:** See ["Quasi Orthogonal Walsh Code State"](#) on page 50

**[:SOURCE<hw>]:BB:C2K:BSTation<st>:CGRoup<di0>:COFFset<ch>:STATE <State>**

This command activates/deactivates the selected channel.

For the traffic channels, this value is specific for the selected radio configuration.

**Parameters:**

<State> 0 | 1 | OFF | ON

\*RST: OFF

**Example:** `BB:C2K:BST2:CGR1:COFF2:STAT OFF`  
Deactivates sub channel 1 to 2 of base station 1.

**Manual operation:** See ["Channel State"](#) on page 51

**[:SOURCE<hw>]:BB:C2K:BSTation<st>:CGRoup<di0>:COFFset<ch>:TPC:DATA <Data>**

Sets the data source for the power control bits of the selected F-FCH or F-DCCH.

Power control is available for sub channel types F-FCH and F-DCCH. F-DCCH is only generated for radio configurations 3, 4 and 5.

For the traffic channels, this value is specific for the selected radio configuration.

**Parameters:**

<Data> ZERO | ONE | PATtern | DLISt

**DLISt**

A data list is used. The data list is selected with the command  
[:SOURce<hw>]:BB:C2K:BSTation<st>:CGRoup<di0>:  
COFFset<ch>:TPC:DATA:DSElect.

**ZERO | ONE**

Internal 0 and 1 data is used.

**PATtern**

Internal data is used. The bit pattern for the data is defined by the command [:SOURce<hw>]:BB:C2K:BSTation<st>:CGRoup<di0>:COFFset<ch>:TPC:DATA:PATtern. The maximum length is 64 bits.

\*RST: ZERO

**Example:**

BB:C2K:BST2:CGR1:RCON 4

Selects radio configuration4 for the first traffic channel of base station 2. This setting is valid for all sub channels of this traffic channel. With RC4, the traffic channel includes an F-DCCH.

BB:C2K:BST2:CGR1:COFF4:TPC:DATA PATT

Selects as the data source for the power control bits of F-DCCH the bit pattern defined with the following command.

BB:C2K:BST2:CGR1:COFF4:TPC:DATA:PATT #HF0C20,19

Defines the bit pattern.

**Manual operation:** See "Data Source - Power Control - BS" on page 58

---

**[:SOURce<hw>]:BB:C2K:BSTation<st>:CGRoup<di0>:COFFset<ch>:TPC:DATA:  
DSElect <DSelect>**

The command selects the data list for the DLISt data source selection.

Power control is available for sub channel types F-DCCH and F-FCH. F-DCCH is only generated for radio configurations 3, 4 and 5.

The lists are stored as files with the fixed file extensions \*.dm\_iqd in a directory of the user's choice. The directory applicable to the following commands is defined with the command MMEMory:CDIR. To access the files in this directory, you only have to give the file name, without the path and the file extension.

For the traffic channels, this value is specific for the selected radio configuration.

**Parameters:**

<DSelect> string

**Example:** `BB:C2K:BST2:CGR1:RCON 4`  
 selects radio configuration RC4 for the first traffic channel of base station 2. This setting is valid for all sub channels of the traffic channel. With RC4, the traffic channel includes a F-DCCH.

`:BB:C2K:BST2:CGR1:COFF4:TPC:DATA DLIS`  
 selects the DLIS data source.

`MMEM:CDIR "/var/user/temp/Lists"`  
 selects the directory for the data lists.

`BB:C2K:BST2:CGR1:COFF4:TPC:DATA:DSEL "cdma_ch4"`  
 selects the file `cdma_ch4` as the data source. This file must be in specified directory and it must have the file extension `*.dm_iqd`.

**Manual operation:** See ["Data Source - Power Control - BS"](#) on page 58

**[:SOURCE<hw>]:BB:C2K:BSTation<st>:CGRoup<di0>:COFFset<ch>:TPC:DATA: PATTern <Pattern>, <BitCount>**

Sets the bit pattern for the `PATTern` selection.

Power control is available for sub channel types F-DCCH and F-FCH. F-DCCH is only generated for radio configurations 3, 4 and 5.

For the traffic channels, this value is specific for the selected radio configuration.

**Parameters:**

<code>&lt;Pattern&gt;</code>	numeric
	*RST: #H0
<code>&lt;BitCount&gt;</code>	integer
	Range: 1 to 64
	*RST: 1

**Example:** `BB:C2K:BST2:CGR1:RCON 4`  
 selects radio configuration RC4 for the first traffic channel of base station 2. This setting is valid for all sub channels of the traffic channel. With RC4, the traffic channel includes a F-DCCH.

`BB:C2K:BST2:CGR1:COFF4:TPC:DATA:PATT #H3F,8`  
 defines the bit pattern for the power control-bits.

**Manual operation:** See ["Data Source - Power Control - BS"](#) on page 58

**[:SOURCE<hw>]:BB:C2K:BSTation<st>:CGRoup<di0>:COFFset<ch>:TPC:MISuse <MisUse>**

The command activates "mis-" use of the power control bits of the selected F-DCCH or F-FCH for controlling the channel powers of these channels.

Power control is available for sub channel types F-DCCH and F-FCH. F-DCCH is only generated for radio configurations 3, 4 and 5.

The bit pattern (see commands `:BB:C2K:BSTation<n>:CGRoup<n>:COFFset<n>:TPC...`) of the power control bits of each channel is used to control the channel power. A "1" leads to an increase of channel powers, a "0" to a reduction of channel powers. Channel power is limited to the range 0 dB to -80 dB. The step width of the change is defined with the command `[ :SOURce<hw> ] :BB:C2K:BSTation<st>:CGRoup<di0>:COFFset<ch>:TPC:PSTep`.

For the traffic channels, this value is specific for the selected radio configuration.

**Parameters:**

<MisUse> 0 | 1 | OFF | ON  
\*RST: OFF

**Example:**

`BB:C2K:BST2:CGR1:RCON 4`  
selects radio configuration RC4 for the first traffic channel of base station 2. This setting is valid for all sub channels of the traffic channel. With RC4, the traffic channel includes a F-DCCH.  
`BB:C2K:BST2:CGR1:COFF4:TPC:MIS ON`  
activates regulation of channel power for DCCH of the first traffic channel of base station 2 via the power control bit pattern.  
`BB:C2K:BST2:CGR1:COFF4:TPC:PST 1 dB`  
sets the step width for the change of channel powers to 1 dB.

**Manual operation:** See ["For Output Power Control - BS"](#) on page 59

`[ :SOURce<hw> ] :BB:C2K:BSTation<st>:CGRoup<di0>:COFFset<ch>:TPC:PSTep <PStep>`

The command defines the step width for the change of channel powers in the case of "mis-" use of the power control bits.

Power control is available for sub channel types F-DCCH and F-FCH. F-DCCH is only generated for radio configurations 3, 4 and 5.

For the traffic channels, this value is specific for the selected radio configuration.

**Parameters:**

<PStep> float  
Range: -10 dB to 10 dB  
Increment: 0.01 dB  
\*RST: 0 dB

**Example:**

`BB:C2K:BST2:CGR1:RCON 4`  
selects radio configuration RC4 for the first traffic channel of base station 2. This setting is valid for all sub channels of the traffic channel. With RC4, the traffic channel includes a F-DCCH.  
`BB:C2K:BST2:CGR1:COFF4:TPC:PST 1 dB`  
sets the step width for the change of channel powers to 1 dB.

**Manual operation:** See ["Power Step \(DPCCH\) - BS"](#) on page 60

---

**[ :SOURce<hw>]:BB:C2K:BSTation<st>:CGRoup<di0>:COFFset<ch>:TPC:READ**  
 <Read>

The command sets the read out mode for the bit pattern of the power control bits.

The bit pattern is defined with the commands :BB:C2K:BST<n>:CGRoup<n>:COFFset<n>:TPC . . . .

Power control is available for sub channel types F-DCCH and F-FCH. F-DCCH is only generated for radio configurations 3, 4 and 5.

For the traffic channels, this value is specific for the selected radio configuration.

**Parameters:**

<Read> CONTInuous | S0A | S1A | S01A | S10A

**CONTInuous**

The bit pattern is used cyclically.

**S0A**

The bit pattern is used once, then the power control bit sequence continues with 0 bits.

**S1A**

The bit pattern is used once, then the power control bit sequence continues with 1 bit.

**S01A**

The bit pattern is used once and then the power control bit sequence is continued with 0 bits and 1 bit alternately.

**S10A**

The bit pattern is used once and then the power control bit sequence is continued with 1 bit and 0 bits alternately.

\*RST: CONTInuous

**Example:**

BB:C2K:BST2:CGR1:RCON 4

Selects radio configuration RC4 for the first traffic channel of base station 2. This setting is valid for all sub channels of the traffic channel. With RC4, the traffic channel includes an F-DCCH.

BB:C2K:BST2:CGR1:COFF4:TPC:READ S0A

'the bit pattern is used once, after which a 0 sequence is generated (applies to F-DCCH of the first traffic channel of base station 2).

**Manual operation:** See "[Read Out Mode \(Power Control\) - BS](#)" on page 59

---

**[ :SOURce<hw>]:BB:C2K:BSTation<st>:CGRoup<di0>:COFFset<ch>:TYPE?**

Queries the channel type.

The channel type is firmly fixed for channel numbers 0-1 to 0-14 (CGR0:COFF1 to CGR0:COFF14), i.e. for the special channels (control and packet channels). The remaining channel numbers are assigned to the individual code channels of the eight possible traffic channels. In this case, the first traffic channel occupies the range 1-1 to 1-8 (CGR1:COFF1 to CGR1:COFF8), the second occupies the range 2-1 to 2-8 (CGR2:COFF1 to CGR2:COFF8), etc. Since the type and number of code channels depends on the radio configuration of the channel, the channels x-2 to x-8 are variously occupied. X-1 is always the fundamental channel (F-FCH) of the traffic channel.

**Return values:**

<Type> F-PICH | F-SYNC | F-PCH | F-TDPICH | F-APICH |  
F-ATDPICH | F-BCH | F-QPCH | F-CPCCH | F-CACH |  
F-CCCH | F-DCCH | F-FCH | F-SCH | F-PDCCH | F-PDCH

**Example:**

BB:C2K:BST2:CGR0:COFF12:TYPE?

Queries type of channel 0 to 12 of base station 2.

Response: F-PDCCH

**Usage:**

Query only

**Manual operation:** See "[Channel Type](#)" on page 47

**[:SOURCE<hw>]:BB:C2K:BSTation<st>:CGRoup<di0>:COFFset<ch>:WCODE**  
<WCode>

Assigns the Walsh Code to the channel. The standard assigns a fixed walsh code to some channels (F-PICH, for example, always uses Walsh code 0). Generally, the Walsh code can only be varied within the range specified by the standard.

For the traffic channels, this value is specific for the selected radio configuration.

The value range of the Walsh code depends on the frame length, the channel coding type and the data rate.

If one of these parameters is changed so that the set Walsh code gets invalid, the next permissible value is automatically set.

**Parameters:**

<WCode> integer  
Range: 0 to 255  
\*RST: 0

**Example:**

BB:C2K:BST1:CGR3:COFF5:WCOD 23

Assigns Walsh code 23 to sub channel 3 to 5 of base station 1.

**Manual operation:** See "[Walsh](#)" on page 49

**[:SOURCE<hw>]:BB:C2K:BSTation<st>:CGRoup<di0>:COFFset<ch>:WLENgth?**

Queries the Walsh Code length of the channel. For the traffic channels, this value is specific for the selected radio configuration.

**Return values:**

<WLength> integer  
 Range: 0 to 255  
 \*RST: 0

**Example:**

BB:C2K:BST1:CGR3:COFF5:WLEN?  
 queries Walsh code length of sub channel 3-5 of base station 1.  
 Response: 64  
 the Walsh code length is 64.

**Usage:** Query only

**Manual operation:** See "[Walsh Length - More Parameters BS](#)" on page 57

**[:SOURCE<hw>]:BB:C2K:BSTation<st>:CGROUP<di0>:RCONfiguration**  
 <RConfiguration>

Selects the radio configuration for the traffic channel. The settings of the channel table parameters are specific for the selected radio configuration.

**Parameters:**

<RConfiguration> 1 | 2 | 3 | 4 | 5  
 \*RST: Traffic channel 1/2: 3; all other traffic channels: 1

**Example:**

BB:C2K:BST2:CGR1:RCON 4  
 selects radio configuration RC4 for the first traffic channel of base station 2. This setting is valid for all sub channels of the traffic channel. With RC4, the traffic channel includes a F-DCCH.

**Manual operation:** See "[Radio Configuration \(RC\)](#)" on page 48

**[:SOURCE<hw>]:BB:C2K:BSTation<st>:DCONflict:MODE <Mode>**

The command switches the order of the spreading codes.

**Parameters:**

<Mode> HAD | BREV  
**HAD**  
 the code channels are displayed in the order determined by the Hadamard matrix. The codes are numbered as Walsh codes according to the standard.  
**BREV**  
 the code channels are displayed in the order defined by the Orthogonal Variable Spreading Factor (OVSF) code tree (3GPP code).  
 \*RST: HAD

**Example:**

BB:C2K:BST2:DCON:MODE HAD  
 selects that the codes are numbered as Walsh codes according to the standard.

**Manual operation:** See "Order - Code Domain BS" on page 55

---

**[[:SOURce<hw>]:BB:C2K:BSTation<st>:DCONflict:RESolve**

The command resolves existing domain conflicts by modifying the Walsh codes of the affected channels.

**Example:**

BB:C2K:BST2:DCON:STAT?

queries whether a code domain conflict exists for base station 2.

Response: 1

there is a conflict.

BB:C2K:BST2:DCON:RES

resolves the code domain error by modifying the Walsh codes of the affected channels.

**Usage:** Event

**Manual operation:** See "Domain Conflict" on page 51

---

**[[:SOURce<hw>]:BB:C2K:BSTation<st>:DCONflict[:STATe]?**

The command queries whether there is (response 1) or is not (response 0) a conflict (overlap) in the hierarchically-structured Walsh codes.

**Return values:**

<State> 0 | 1 | OFF | ON

**Example:**

BB:C2K:BST2:DCON:STAT?

queries whether a code domain conflict exists for base station 2.

Response: 0

there is no conflict.

**Usage:** Query only

**Manual operation:** See "Domain Conflict" on page 51

---

**[[:SOURce<hw>]:BB:C2K:BSTation<st>:PDCHannel:PINTerval <PInterval>**

The command sets the interval between two data packets for F-PDCH. The range depends on the ARB settings sequence length (:BB:C2K:SLENGth). The values 80 ms, 40 ms, 20 ms, 10 ms and 5 ms can always be set, and the maximum value is 2000 ms. All intermediate values must satisfy the condition:

**Sequence Length \* 80ms/2<sup>n</sup>**, where n is a whole number.

**Parameters:**

<PInterval> float

Range: 5 ms to 2000 ms

Increment: 0.005

\*RST: 20 ms

**Example:**

BB:C2K:BST2:PDCH:PINT 10 ms

sets an interval of 10 ms between two data packets.

**Manual operation:** See "[Packet Interval - More Params F-PDCHs BS](#)" on page 66

**[:SOURce<hw>]:BB:C2K:BSTation<st>:PDCHannel:PSETup <PSetup>**

Selects for F-PDCH if all subpackets are generated using the same settings or if the settings of subchannel 1 are valid for all sub channels. However, the value of "Number of Bits per Encoder Packet" is a quality of the complete encoder packet, therefore it is always set for all sub packet channels via the entry for sub channel 1.

**Parameters:**

<PSetup> 0 | 1 | OFF | ON

**ON**

Packet parameters can be changed only for sub packet 1, all sub packets are generated with these settings.

**OFF**

Packet parameters can be set individually for each sub packet.

\*RST: 1

**Example:**

BB:C2K:BST2:PDCH:PSET OFF

selects that all sub packets can be configured separately.

**Manual operation:** See "[Same Packet Setup for all Subpackets - More Params F-PDCHs BS](#)" on page 66

**[:SOURce<hw>]:BB:C2K:BSTation<st>:PDCHannel:SUBPacket<di>:ID <Id>**

The command selects the sub packet ID for F\_PDCH. The sub packet ID determines the sub packet symbol selection and selects one of four available subpackets of the encoder packets. The SPID of sub packet 1 is always 1.

**Parameters:**

<Id> 0 | 1 | 2 | 3

Range: 0 to 3

\*RST: 0

**Example:**

BB:C2K:BST2:PDCH:SUBP3:ID 3

selects SPID 3 for sub packet 3.

**Manual operation:** See "[Subpacket ID \(SPID\) - More Params F-PDCHs BS](#)" on page 67

**[:SOURce<hw>]:BB:C2K:BSTation<st>:PDCHannel:SUBPacket<di>:PARAMeters <Parameters>**

Selects a fixed combination of parameters "Bits per Encoder Packet", "Number of 32-Chip Walsh Channels", "Subpacket Data Rate", "Number of Slots per Subpackets" and "Modulation Order". These combinations are shown in the following list in the form of a table for all five parameters.

The complete range of 127 possible combinations is only available for subpacket 1. If "Same Packet Setup for all Subpackets" is enabled

(SOUR:BB:C2K:BST:PDCH:PSET ON), this command is only valid for subpacket 1.

Parameter of command SOUR:BB: C2K:BST: PDCH:PAR	Number of Bits per Encoder Packet	Number of 32-Chip Walsh Channels	Subpacket Data Rate (kbps)	Number of Slots per Subpacket	Modulation Order
1	2328	28	1862.4	1	8-PSK
2	3864	27	1545.6	2	QPSK
3	3096	26	2476.8	1	16-QAM
4	3864	26	3091.2	1	16-QAM
5	1560	25	1248.0	1	QPSK
6	2328	25	1862.4	1	8-PSK
7	3096	25	1238.4	2	QPSK
8	3864	25	1545.6	2	8-PSK
9	2328	23	931.2	2	QPSK
10	2328	23	1862.4	1	16-QAM
11	3096	23	2476.8	1	16-QAM
12	3864	23	1545.6	2	8-PSK
13	1560	22	1248.0	1	QPSK
14	3096	22	1238.4	2	QPSK
15	1560	21	1248.0	1	8-PSK
16	3096	21	1238.4	2	8-PSK
17	3096	21	2476.8	1	16-QAM
18	3864	21	1545.6	2	8-PSK
19	1560	20	624.0	2	QPSK
20	2328	20	465.6	4	QPSK
21	2328	20	931.2	2	QPSK
22	2328	20	1862.4	1	16-QAM
23	3096	20	619.2	4	QPSK
24	408	19	326.4	1	QPSK
25	792	19	316.8	2	QPSK
26	792	19	633.6	1	QPSK
27	1560	19	1248.0	1	8-PSK
28	3096	19	1238.4	2	8-PSK

Parameter of command SOUR:BB: C2K:BST: PDCH:PAR	Number of Bits per Encoder Packet	Number of 32-Chip Walsh Channels	Subpacket Data Rate (kbps)	Number of Slots per Subpacket	Modulation Order
29	3864	19	772.8	4	QPSK
30	3864	19	1545.6	2	16-QAM
31	2328	18	1862.4	1	16-QAM
32	1560	17	1248.0	1	8-PSK
33	2328	17	931.2	2	QPSK
34	3096	17	1238.4	2	8-PSK
35	3864	17	1545.6	2	16-QAM
36	2328	16	1862.4	1	16-QAM
37	3096	16	619.2	4	QPSK
38	3864	16	772.8	4	QPSK
39	792	15	633.6	1	QPSK
40	1560	15	624.0	2	QPSK
41	1560	15	1248.0	1	16-QAM
42	2328	15	931.2	2	8-PSK
43	3096	15	1238.4	2	16-QAM
44	3864	15	1545.6	2	16-QAM
45	1560	14	312.0	4	QPSK
46	2328	14	465.6	4	QPSK
47	3864	14	772.8	4	QPSK
48	3864	14	1545.6	2	16-QAM
49	792	13	633.6	1	QPSK
50	1560	13	624.0	2	QPSK
51	1560	13	1248.0	1	16-QAM
52	2328	13	931.2	2	8-PSK
53	3096	13	619.2	4	QPSK
54	3096	13	1238.4	2	16-QAM
55	3864	13	1545.6	2	16-QAM
56	1560	12	1248.0	1	16-QAM
57	3096	12	1238.4	2	16-QAM
58	3864	12	772.8	4	8-PSK
59	408	11	326.4	1	QPSK

Parameter of command SOUR:BB: C2K:BST: PDCH:PAR	Number of Bits per Encoder Packet	Number of 32-Chip Walsh Channels	Subpacket Data Rate (kbps)	Number of Slots per Subpacket	Modulation Order
60	792	11	158.4	4	QPSK
61	792	11	316.8	2	QPSK
62	792	11	633.6	1	QPSK
63	1560	11	624.0	2	QPSK
64	1560	11	1248.0	1	16-QAM
65	2328	11	465.6	4	QPSK
66	2328	11	931.2	2	16-QAM
67	3096	11	619.2	4	QPSK
68	3096	11	1238.4	2	16-QAM
69	3864	11	772.8	4	8-PSK
70	792	10	633.6	1	8-PSK
71	1560	10	624.0	2	8-PSK
72	2328	10	931.2	2	16-QAM
73	3096	10	619.2	4	8-PSK
74	792	9	633.6	1	8-PSK
75	1560	9	312.0	4	QPSK
76	1560	9	624.0	2	8-PSK
77	2328	9	465.6	4	QPSK
78	2328	9	931.2	2	16-QAM
79	3096	9	619.2	4	8-PSK
80	3864	9	772.8	4	16-QAM
81	408	8	163.2	2	QPSK
82	408	8	326.4	1	QPSK
83	792	8	316.8	2	QPSK
84	792	8	633.6	1	16-QAM
85	1560	8	624.0	2	16-QAM
86	2328	8	465.6	4	8-PSK
87	2328	8	931.2	2	16-QAM
88	3096	8	619.2	4	16-QAM
89	3864	8	772.8	4	16-QAM
90	408	7	326.4	1	QPSK

Parameter of command SOUR:BB: C2K:BST: PDCH:PAR	Number of Bits per Encoder Packet	Number of 32-Chip Walsh Channels	Subpacket Data Rate (kbps)	Number of Slots per Subpacket	Modulation Order
91	792	7	316.8	2	QPSK
92	792	7	633.6	1	16-QAM
93	1560	7	312.0	4	QPSK
94	1560	7	624.0	2	16-QAM
95	2328	7	465.6	4	8-PSK
96	3096	7	619.2	4	16-QAM
97	3864	7	772.8	4	16-QAM
98	408	6	326.4	1	QPSK
99	792	6	158.4	4	QPSK
100	792	6	316.8	2	QPSK
101	792	6	633.6	1	16-QAM
102	1560	6	312.0	4	QPSK
103	1560	6	624.0	2	16-QAM
104	2328	6	465.6	4	16-QAM
105	3096	6	619.2	4	16-QAM
106	408	5	163.2	2	QPSK
107	408	5	326.4	1	8-PSK
108	792	5	316.8	2	8-PSK
109	1560	5	312.0	4	8-PSK
110	2328	5	465.6	4	16-QAM
111	408	4	81.6	4	QPSK
112	408	4	163.2	2	QPSK
113	408	4	326.4	1	16-QAM
114	792	4	158.4	4	QPSK
115	792	4	316.8	2	16-QAM
116	1560	4	312.0	4	16-QAM
117	2328	4	465.6	4	16-QAM
118	408	3	81.6	4	QPSK
119	408	3	163.2	2	QPSK
120	408	3	326.4	1	16-QAM
121	792	3	158.4	4	QPSK

Parameter of command SOUR:BB: C2K:BST: PDCH:PAR	Number of Bits per Encoder Packet	Number of 32-Chip Walsh Channels	Subpacket Data Rate (kbps)	Number of Slots per Subpacket	Modulation Order
122	792	3	316.8	2	16-QAM
123	1560	3	312.0	4	16-QAM
124	408	2	81.6	4	QPSK
125	408	2	163.2	2	16-QAM
126	792	2	158.4	4	16-QAM
127	408	1	81.6	4	16-QAM

**Parameters:**

&lt;Parameters&gt; 1 to 127

\*RST: 1

**Example:**

BB:C2K:BST2:PDCH:SUBP1:PAR 48

selects combination of parameters with index 48 (see following table).

**Manual operation:**See " [PDCH Subpacket Table Parameters - More Params F-PDCHs BS](#) " on page 68

**[:SOURce<hw>]:BB:C2K:BSTation<st>:PDCHannel:SUBPacket<di>:STATe**  
<State>

This command activates/deactivates the selected sub packet for F\_PDCH. Sub packet 1 is always active.

**Parameters:**

&lt;State&gt; 0 | 1 | OFF | ON

\*RST: OFF

**Example:**

BB:C2K:BST2:PDCH:SUBP3:STAT ON

activates sub packet 3.

**Manual operation:**See " [Subpacket State - More Params F-PDCHs BS](#) " on page 67

**[:SOURce<hw>]:BB:C2K:BSTation<st>:PDCHannel:SUBPacket<di>:TOFFset**  
<TOffset>

Sets start of the sub packet relative to the start of the packet interval. The offset is entered in slots. Sub packet 1 has offset 0. The value range for the individual subpackets depends on the settings of the other subpackets. The time slot offsets of the other sub packet have to be entered in ascending order. Also, two packets cannot be sent at the same time.

In total the maximum value depends on the selected packet interval and the number of slots per sub packet as follows:

#### Packet Interval/1.25 ms - Number of Slots per Subpacket.

##### Parameters:

<TOffset> integer  
 Range: 0 to max  
 \*RST: 0|1|2|3

##### Example:

BB:C2K:BST2:PDCH:SUBP3:TOFF 4  
 enters at time slot offset of 4 slots. Sub packet 3 is sent 4 slots after the begin of the packet interval.

**Manual operation:** See "[Time Slot Offset - More Params F-PDCHs BS](#)" on page 67

#### [[:SOURce<hw>]:BB:C2K:BSTation<st>:PDCHannel:SUBPacket<di>:WCODes?

The command queries the resulting Walsh codes for the selected sub packet of F-PDCH. Packet channels may be assigned to more than one code channel.

##### Return values:

<WCodes> string

##### Example:

BB:C2K:BST2:PDCH:SUBP3:RES:WCOD?  
 queries the resulting Walsh codes for sub packet 3 of F-PDCH of base station 2.  
 Response: "31, 15, 23"  
 the resulting walsh codes are 31,15,23.

**Usage:** Query only

**Manual operation:** See "[Resulting Walsh Codes - More Params F-PDCHs BS](#)" on page 69

#### [[:SOURce<hw>]:BB:C2K:BSTation<st>:PDCHannel:WINDex <WIndex>

The command selects a standard Walsh set for F-PDCH. Four different sets are defined in the standard.

##### Parameters:

<WIndex> 0 | 1 | 2 | 3  
 \*RST: 0

##### Example:

BB:C2K:BST2:PDCH:WIND 2  
 selects set 2 for PDCH of base station 2.

**Manual operation:** See "[Walsh Code Column Index - More Params F-PDCHs BS](#)" on page 66

---

**[ :SOURce<hw>]:BB:C2K:BSTation<st>:PNOFset <PnOffset>**

The command sets the PN offset (short code) of the base station. The PN offset permits signals of different base stations to be distinguished.

**Parameters:**

<PnOffset>                    integer  
                                  Range:        0 to 511  
                                  \*RST:        0

**Example:**                    BB:C2K:BST3:PNOF 123  
                                  sets a PN offset of 123 for base station 3.

**Manual operation:**    See "[PN Offset](#)" on page 45

---

**[ :SOURce<hw>]:BB:C2K:BSTation<st>:QWSet <QwSet>**

The command selects the quasi orthogonal Walsh code set. The standard defines three different sets.

The quasi-orthogonal Walsh codes are used for a given channel if `[ :SOURce<hw> ] : BB:C2K:BSTation<st>:CGRoup<di0>:COFFset<ch>:QWCode:STATe` is ON.

**Parameters:**

<QwSet>                        integer  
                                  Range:        1 to 3  
                                  \*RST:        1

**Example:**                    BB:C2K:BST2:QWS 2  
                                  selects set 2 for base station 2.

**Manual operation:**    See "[Quasi orth Walsh Set](#)" on page 45

---

**[ :SOURce<hw>]:BB:C2K:BSTation<st>:STATe <State>**

The command activates and deactivates the specified base station.

**Parameters:**

<State>                        0 | 1 | OFF | ON  
                                  \*RST:        OFF

**Example:**                    BB:C2K:BST2:STAT OFF  
                                  deactivates base station 2.

**Manual operation:**    See "[Base Station/Mobile Station State](#)" on page 38

---

**[ :SOURce<hw>]:BB:C2K:BSTation<st>:TDELay <TDelay>**

Sets the time shift of the selected base station compared to base station 1.

**Parameters:**

<TDelay> integer  
 Range: 0 to dynamic  
 \*RST: 0  
 Default unit: chip

**Example:**

BB:C2K:BST2:TDEL 256  
 shifts base station 2 by 256 chips compared to base station 1.

**Manual operation:** See ["Time Delay"](#) on page 44

**[ :SOURce<hw>]:BB:C2K:BSTation<st>:TDIVersity <TDiversity>**

The command activates and deactivates signal calculation with transmit diversity (OFF). To activate transmit diversity, the antenna must be specified whose signals are to be simulated (ANT1 or ANT2).

The diversity scheme is selected using command `[ :SOURce<hw> ] :BB:C2K:BSTation<st>:TDIVersity:MODE`.

**Parameters:**

<TDiversity> OFF | ANT1 | ANT2  
**OFF**  
 No transmit diversity.  
**ANT1**  
 Calculate and apply the output signal for antenna 1.  
**ANT2**  
 Calculate and apply the output signal for antenna 2.  
 \*RST: OFF

**Example:**

BB:C2K:BST2:TDIV ANT2  
 Activates transmit diversity, the signal of antenna 2 is simulated.

**Manual operation:** See ["Transmit Diversity"](#) on page 44

**[ :SOURce<hw>]:BB:C2K:BSTation<st>:TDIVersity:MODE <Mode>**

The command selects the diversity scheme.

Command `[ :SOURce<hw> ] :BB:C2K:BSTation<st>:TDIVersity` activates transmit diversity and selects the antenna.

**Parameters:**

<Mode> OTD | STS  
**OTD**  
 Orthogonal Transmit Diversity Mode.  
**STS**  
 Space Time Spreading Mode.  
 \*RST: OTD

**Example:**                   BB:C2K:BST2:TDiv:MODE OTD  
 selects scheme OTD for Transmit Diversity.  
 BB:C2K:BST2:TDiv ANT2  
 activates transmit diversity, the signal of antenna 2 is simulated.

**Manual operation:** See "Diversity Mode" on page 44

## 4.8 Mobile Station Settings

The `SOURCE:BB:C2K:MSTation` system contains commands for setting mobile stations.

The commands of this system only take effect when the CDMA2000 standard is activated, the UP transmission direction is selected and the particular mobile station is enabled:

- `SOURCE:BB:C2K:STATE ON`
- `SOURCE:BB:C2K:LINK UP`
- `SOURCE:BB:C2K:MSTation2:STATE ON`



For the code channels of a traffic channels, the settings of the channel table parameters are specific for the selected radio configuration. I.e. a complete set of settings exists for each of the four possible radio configurations.

<code>[:SOURCE&lt;hw&gt;]:BB:C2K:MSTation:ADDITIONAL:COUNT</code> .....	138
<code>[:SOURCE&lt;hw&gt;]:BB:C2K:MSTation:ADDITIONAL:LCMASK:STEP</code> .....	138
<code>[:SOURCE&lt;hw&gt;]:BB:C2K:MSTation:ADDITIONAL:POWER:OFFSET</code> .....	138
<code>[:SOURCE&lt;hw&gt;]:BB:C2K:MSTation:ADDITIONAL:STATE</code> .....	139
<code>[:SOURCE&lt;hw&gt;]:BB:C2K:MSTation:ADDITIONAL:TDELAY:STEP</code> .....	139
<code>[:SOURCE&lt;hw&gt;]:BB:C2K:MSTation:PRESET</code> .....	139
<code>[:SOURCE&lt;hw&gt;]:BB:C2K:MSTation&lt;st&gt;:CCODING:MODE</code> .....	140
<code>[:SOURCE&lt;hw&gt;]:BB:C2K:MSTation&lt;st&gt;:CHANnel&lt;ch&gt;:DATA</code> .....	140
<code>[:SOURCE&lt;hw&gt;]:BB:C2K:MSTation&lt;st&gt;:CHANnel&lt;ch&gt;:DATA:DSElect</code> .....	141
<code>[:SOURCE&lt;hw&gt;]:BB:C2K:MSTation&lt;st&gt;:CHANnel&lt;ch&gt;:DATA:PATTERN</code> .....	141
<code>[:SOURCE&lt;hw&gt;]:BB:C2K:MSTation&lt;st&gt;:CHANnel&lt;ch&gt;:DATA:RATE</code> .....	142
<code>[:SOURCE&lt;hw&gt;]:BB:C2K:MSTation&lt;st&gt;:CHANnel&lt;ch&gt;:FLenGth</code> .....	142
<code>[:SOURCE&lt;hw&gt;]:BB:C2K:MSTation&lt;st&gt;:CHANnel&lt;ch&gt;:POWER</code> .....	143
<code>[:SOURCE&lt;hw&gt;]:BB:C2K:MSTation&lt;st&gt;:CHANnel&lt;ch&gt;:SPReading?</code> .....	143
<code>[:SOURCE&lt;hw&gt;]:BB:C2K:MSTation&lt;st&gt;:CHANnel&lt;ch&gt;:STATE</code> .....	143
<code>[:SOURCE&lt;hw&gt;]:BB:C2K:MSTation&lt;st&gt;:CHANnel&lt;ch&gt;:TYPE?</code> .....	144
<code>[:SOURCE&lt;hw&gt;]:BB:C2K:MSTation&lt;st&gt;:CHANnel&lt;ch&gt;:WCODE?</code> .....	144
<code>[:SOURCE&lt;hw&gt;]:BB:C2K:MSTation&lt;st&gt;:LCMASK</code> .....	145
<code>[:SOURCE&lt;hw&gt;]:BB:C2K:MSTation&lt;st&gt;:MODE</code> .....	145
<code>[:SOURCE&lt;hw&gt;]:BB:C2K:MSTation&lt;st&gt;:RCONfiguration</code> .....	146
<code>[:SOURCE&lt;hw&gt;]:BB:C2K:MSTation&lt;st&gt;:STATE</code> .....	146
<code>[:SOURCE&lt;hw&gt;]:BB:C2K:MSTation&lt;st&gt;:TPC:DATA</code> .....	146
<code>[:SOURCE&lt;hw&gt;]:BB:C2K:MSTation&lt;st&gt;:TPC:DATA:DSElect</code> .....	147
<code>[:SOURCE&lt;hw&gt;]:BB:C2K:MSTation&lt;st&gt;:TPC:DATA:PATTERN</code> .....	147

<a href="#">[:SOURce&lt;hw&gt;]:BB:C2K:MSTation&lt;st&gt;:TPC:MISuse.....</a>	148
<a href="#">[:SOURce&lt;hw&gt;]:BB:C2K:MSTation&lt;st&gt;:TPC:PSTep.....</a>	148
<a href="#">[:SOURce&lt;hw&gt;]:BB:C2K:MSTation&lt;st&gt;:TPC:READ.....</a>	148

---

#### **[:SOURce<hw>]:BB:C2K:MSTation:ADDITIONAL:COUNT <Count>**

Sets the number of additional mobile stations.

##### **Parameters:**

<Count>                    integer  
 Range:                    1 to 64  
 \*RST:                    4

##### **Example:**

```
BB:C2K:MST:ADD:COUN 20
sets 20 additional mobile stations.
BB:C2K:MST:ADD:POW:OFFS -3.0
sets the power offset to -3 dB.
BB:C2K:MST:ADD:LCM:STEP #H1
sets the step width for increasing the LC mask to 1.
BB:C2K:MST:ADD:STAT ON
connects the 20 mobile stations to the CDMA signal.
```

**Manual operation:** See " [Number of Additional MS](#) " on page 42

---

#### **[:SOURce<hw>]:BB:C2K:MSTation:ADDITIONAL:LCMask:STEP <Step>**

Sets the step width for increasing the LC mask of the additional mobile stations. The start value is the LC mask of MS4.

##### **Parameters:**

<Step>                    24 bits  
 \*RST:                    #H1

##### **Example:**

```
BB:C2K:MST:ADD:LCM:STEP #H55
sets the step width for increasing the long code mask to #H55.
```

**Manual operation:** See " [LC Mask Step](#) " on page 42

---

#### **[:SOURce<hw>]:BB:C2K:MSTation:ADDITIONAL:POWER:OFFSet <Offset>**

The command sets the power offset of the active channels of the additional mobile stations relative to the power of the active channels of the reference station MS4.

The offset applies to all the additional mobile stations. The resultant overall power must fall within the range 0 ... - 80 dB. If the value is above or below this range, it is limited automatically.

##### **Parameters:**

<Offset>                    float  
 Range:                    -80 dB to 0 dB  
 Increment:                0.01 dB  
 \*RST:                    0 dB

**Example:** `BB:C2K:MST:ADD:POW:OFFS -3.0`  
sets the offset to -3 dB.

**Manual operation:** See " [Power Offset](#) " on page 43

**[:SOURCE<hw>]:BB:C2K:MSTation:ADDITIONal:STATe <State>**

The command activates additional mobile stations.

**Parameters:**

<State> 0 | 1 | OFF | ON  
\*RST: OFF

**Example:** `BB:C2K:MST:ADD:STAT ON`  
connects the additional mobile stations to the CDMA2000 signal.

**Manual operation:** See " [State](#) " on page 42

**[:SOURCE<hw>]:BB:C2K:MSTation:ADDITIONal:TDELay:STEP <Step>**

Sets the step width for the time delay of the additional mobile stations to one another. The start value returns the time delay of MS4.

**Parameters:**

<Step> integer  
Range: 0 to 1535 (1 frame)  
Increment: 1  
\*RST: 0  
Default unit: chip

**Example:** `BB:C2K:MST:ADD:TDEL:STEP 256`  
shifts each of the mobile stations 256 chips apart, starting from the time delay of MS4.

**Manual operation:** See " [Time Delay Step](#) " on page 43

**[:SOURCE<hw>]:BB:C2K:MSTation:PRESet**

A standardized default for all the mobile stations (\*RST values specified for the commands).

See " [Reset All Mobile Stations](#) " on page 36 for an overview.

**Example:** `SOURCE1:BB:C2K:MSTation:PRESet`

**Usage:** Event

**Manual operation:** See " [Reset All Mobile Stations](#) " on page 36

---

```
[ :SOURce<hw>]:BB:C2K:MSTation<st>:CCODing:MODE <Mode>
```

The command selects the channel coding mode.

**Parameters:**

<Mode>                    OFF | COMPlete | NOINterleaving | OINterleaving

**OFF**  
Channel coding is deactivated.

**COMPlete**  
The complete channel coding is performed. The channel coding procedure can slightly vary depending on channel type, frame length and data rate.

**OINterleaving**  
Except for the block interleaver, the whole channel coding procedure is carried out.

**NOINterleaving**  
In this mode, only block interleaver is used for coding.

\*RST:            COMPlete

**Example:**

```
BB:C2K:MST:CCOD:MODE OFF
```

Deactivates channel coding for mobile station 1.

**Manual operation:** See "[Channel Coding - MS](#)" on page 71

---

```
[ :SOURce<hw>]:BB:C2K:MSTation<st>:CHANnel<ch>:DATA <Data>
```

The command sets the data source for the specified channel.

The data source for the power control bits is selected with the command [ :[SOURce<hw>](#)]:[BB:C2K:MSTation<st>](#):[TPC:DATA](#). For the traffic channels, this value is specific for the selected radio configuration.

**Parameters:**

<Data>                    ZERO | ONE | PATTern | PN9 | PN11 | PN15 | PN16 | PN20 | PN21 | PN23 | DLISt

**PNxx**  
The pseudo-random sequence generator is used as the data source. Different random sequence lengths can be selected.

**DLISt**  
A data list is used. The data list is selected with the command [ :[SOURce<hw>](#)]:[BB:C2K:MSTation<st>](#):[CHANnel<ch>](#):[DATA:DSElect](#).

**ZERO | ONE**  
Internal 0 and 1 data is used.

**PATTern**  
Internal data is used. The bit pattern for the data is defined by the command [ :[SOURce<hw>](#)]:[BB:C2K:MSTation<st>](#):[CHANnel<ch>](#):[DATA:PATTern](#).

\*RST:            PN9

**Example:** `BB:C2K:MST1:CHAN2:DATA PN16`  
 Selects as the data source for channel 2 of mobile station 1, internal PRBS data with a sequence length of  $2^{16}-1$ .

**Manual operation:** See "Data - MS" on page 77

**[:SOURCE<hw>]:BB:C2K:MSTation<st>:CHANNEL<ch>:DATA:DSElect <DSelect>**

The command selects the data list for the DLIS data source selection.

The lists are stored as files with the fixed file extensions `*.dm_iqd` in a directory of the user's choice. The directory applicable to the following commands is defined with the command `MMEMoRY:CDIR`. To access the files in this directory, you only have to give the file name, without the path and the file extension.

For the traffic channels, this value is specific for the selected radio configuration.

**Parameters:**

<DSelect>                    string

**Example:**

`BB:C2K:MST1:CHAN1:DATA DLIS`  
 selects the Data Lists data source.  
`MMEMoRY:CDIR "/var/user/temp/Lists"`  
 selects the directory for the data lists.  
`BB:C2K:MST1:CHAN1:DATA:DSEL "dpcch_13"`  
 selects file 'cdma\_13' as the data source. This file must be in specified directory and it must have the file extension `*.dm_iqd`.

**Manual operation:** See "Data - MS" on page 77

**[:SOURCE<hw>]:BB:C2K:MSTation<st>:CHANNEL<ch>:DATA:PATtern <Pattern>, <BitCount>**

Sets the bit pattern for the data component when the PATtern data source is selected. The first parameter determines the bit pattern (choice of hexadecimal, octal or binary notation), the second specifies the number of bits to use.

For the traffic channels, this value is specific for the selected radio configuration.

**Parameters:**

<Pattern>                    numeric  
                               \*RST:        #H0

<BitCount>                  integer  
                               Range:        1 to 64  
                               \*RST:        1

**Example:**

`BB:C2K:MST1:CHAN1:DATA PATT`  
 selects Pattern data source.  
`BB:C2K:MST1:CHAN1:DATA:PATT #H800FFFF80003FFE,`  
`60`  
 defines the bit pattern.

**Manual operation:** See " [Data - MS](#) " on page 77

---

**[ :SOURce<hw>]:BB:C2K:MSTation<st>:CHANnel<ch>:DATA:RATE <Rate>**

The command sets the data rate for the specified channel. The value range depends on the channel type, the selected radio configuration and the frame length.

For the traffic channels, this value is specific for the selected radio configuration.

The value range of the data rate depends on the channel type and the frame length. If the frame length is changed so that the set data rate becomes invalid, the next permissible value is automatically set.

**Parameters:**

<Rate> DR1K2 | DR1K3 | DR1K5 | DR1K8 | DR2K4 | DR2K7 | DR3K6 |  
 DR4K8 | DR7K2 | DR9K6 | DR14K4 | DR19K2 | DR28K8 |  
 DR38K4 | DR57K6 | DR76K8 | DR115K2 | DR153K6 |  
 DR230K4 | DR259K2 | DR307K2 | DR460K8 | DR518K4 |  
 DR614K4 | DR1036K8 | NUSed  
 \*RST: R-DCCH: DR9K6; R-FCH: DR1K5; R-SCH: DR1K5;  
 R-ACC: DR4K8

**Example:**

BB:C2K:MST2:MODE TRAF  
 selects operating mode traffic.  
 BB:C2K:MST2:RCON 3  
 selects radio configuration 3 for the traffic channel.  
 BB:C2K:MST2:CHAN3:DATA:RATE DR4K8  
 sets a data rate of 4.8 kbps for channel 3 f mobile station 2 (R-FCH in this configuration).

**Manual operation:** See " [Data Rate - MS](#) " on page 76

---

**[ :SOURce<hw>]:BB:C2K:MSTation<st>:CHANnel<ch>:FLENgth <FLength>**

The command sets the frame length of the selected channel. The value range depends on the channel type and the selected radio configuration

For the traffic channels, this value is specific for the selected radio configuration.

The frame length affects the data rates that are possible within a channel. Changing the frame length may lead to a change of data rate.

**Parameters:**

<FLength> 5 | 10 | 20 | 26.6 | 40 | 80  
 \*RST: 20 ms

**Example:**

BB:C2K:MST:CHAN3:FLEN 5 ms  
 sets the frame length of sub channel 3 to 5 ms.

**Manual operation:** See " [Frame Length - MS](#) " on page 76

---

**[:SOURCE<hw>]:BB:C2K:MSTation<st>:CHANNEL<ch>:POWER <Power>**

Sets the channel power relative to the powers of the other channels. This setting also determines the starting power of the channel for Misuse Output Power Control.

With the command `[ :SOURCE<hw> ] :BB:C2K:POWER:ADJUST`, the power of all the activated channels is adapted so that the total power corresponds to 0 dB. This does not change the power ratio among the individual channels.

For the traffic channels, this value is specific for the selected radio configuration.

**Parameters:**

<Power> float  
 Range: -80 to 0  
 Increment: 0.01  
 \*RST: 0

**Example:**

BB:C2K:MST2:CHAN3:POW -10dB

Sets the channel power of sub channel 3 of mobile station 2 dB to -10 dB relative to the power of the other channels.

**Manual operation:** See " [Power - MS](#) " on page 77

---

**[:SOURCE<hw>]:BB:C2K:MSTation<st>:CHANNEL<ch>:SPREADING?**

Queries the spreading factor of the channel. The spreading factor corresponds to the length of the employed Walsh code. The Walsh codes to be used are specified by the standard and cannot be chosen.

For the traffic channels, this value is specific for the selected radio configuration.

**Return values:**

<Spreading> integer  
 Range: 0 to 255  
 \*RST: 0

**Example:**

BB:C2K:MST2:CHAN1:SPR?

Queries the spreading factor of channel 1 of mobile station 2.

Response: 32

**Usage:** Query only

**Manual operation:** See " [Spread- MS](#) " on page 77

---

**[:SOURCE<hw>]:BB:C2K:MSTation<st>:CHANNEL<ch>:STATE <State>**

This command activates/deactivates the selected channel.

For the traffic channels, this value is specific for the selected radio configuration.

**Parameters:**

<State> 0 | 1 | OFF | ON  
 \*RST: OFF

**Example:** BB:C2K:MST2:CHAN2:STAT OFF  
deactivates sub channel 2 of mobile station 2.

**Manual operation:** See " [Channel State - MS](#) " on page 78

**[:SOURCE<hw>]:BB:C2K:MSTation<st>:CHANnel<ch>:TYPE?**

The command queries the channel type. The channel type depends on the selected operating mode and, for the sub channels of the traffic channel, from the selected radio configuration.

**Return values:**

<Type> R-PICH | R-ACH | R-EACH | R-CCCH | R-DCCH | R-FCH |  
R-SCCH | R-SCH2 | R-SCH1

**R-ACH**

Access Channel.

**R-EACH**

Enhanced Access Channel

**R-CCCH**

Common Control Channel

**R-PICH**

Pilot Channel.

**R-DCCH**

Dedicated Control Channel

**R-FCH**

Fundamental Channel

**R-SCHx**

Supplemental Channel 1 | 2

**R-SCCH**

Supplemental Control Channel

**Example:** BB:C2K:MST2:CHAN2:TYPE?  
queries type of channel 2.  
Response: R-SCCH  
channel 2 is a Supplemental Control Channel.

**Usage:** Query only

**Manual operation:** See " [Channel Type - MS](#) " on page 75

**[:SOURCE<hw>]:BB:C2K:MSTation<st>:CHANnel<ch>:WCODe?**

Queries the Walsh code. The standard assigns a fixed walsh code to some channels. For the traffic channels, this value is specific for the selected radio configuration.

**Return values:**

<WCode> integer  
Range: 0 to 255  
\*RST: 0

**Example:** `BB:C2K:MST1:CHAN3:WCOD?`  
 Queries the Walsh code of channel 3 of mobile station 1.  
 Response: 3  
 The Walsh code is 3.

**Usage:** Query only

**Manual operation:** See " [Walsh - MS](#) " on page 76

**[:SOURCE<hw>]:BB:C2K:MSTation<st>:LCMask <LcMask>**

Sets the mask of the Long Code Generator of the mobile station.

**Parameters:**

<LcMask> 42 bits  
 \*RST: #H0

**Example:** `BB:C2K:MST1:LCM #H55`  
 sets the Long Codes to #H55.

**Manual operation:** See " [LC Mask \(hex\) - MS](#) " on page 71

**[:SOURCE<hw>]:BB:C2K:MSTation<st>:MODE <Mode>**

The command selects operating mode for the mobile station. The channel-specific parameters are set with commands `SOUR:BB:C2K:MST<n>:CHANnel<n>: . . . n.`

**Parameters:**

<Mode> TRAFFic | ACCess | EACCess | CCONtrol

**TRAFFic**

The mobile station generates a single traffic channel. A traffic channel consists of up to eight sub channels depending on the selected radio configuration (R-FCH, R-SCCH, R-SCH, R-DCCH). This mode corresponds to the standard mode of a mobile station during voice and data transmission.

**ACCess**

The mobile station generates an access channel (R-ACH). This channel is needed to set up the connection between the mobile station and the base station.

**EACCess**

The mobile station generates an enhanced access channel (R-ACH) and a pilot channel (R-PICH).

**CCONtrol**

The mobile station generates a common control channel (R-ACH) and a pilot channel (R-PICH).

\*RST: TRAFFic

**Example:** `BB:C2K:MST1:MODE TRAF`  
 Switches the mobile station into standard mode - voice and data transmission.

**Manual operation:** See " [Operation Mode - MS](#) " on page 70

---

**[ :SOURce<hw>]:BB:C2K:MSTation<st>:RCONfiguration <RConfiguration>**

The command selects the radio configuration for the traffic channel.

The settings of the channel table parameters are specific for the selected radio configuration.

A separate set of settings of all channel table parameters for each radio configuration is provided. If the radio configuration is changed, the set of channel table values belonging to this RC is automatically activated.

**Parameters:**

<RConfiguration> 1 | 2 | 3 | 4  
\*RST: 3

**Example:**

BB:C2K:MST2:MODE TRAF  
switches mobile station 2 into standard mode - voice and data transmission.  
BB:C2K:MST2:RCON 3  
selects radio configuration 3. With RC3, the traffic channel includes five sub channels.

**Manual operation:** See " [Radio Configuration - MS](#) " on page 71

---

**[ :SOURce<hw>]:BB:C2K:MSTation<st>:STATE <State>**

The command activates and deactivates the specified mobile station.

**Parameters:**

<State> 0 | 1 | OFF | ON  
\*RST: OFF

**Example:**

BB:C2K:MST2:STAT OFF  
deactivates mobile station 2.

**Manual operation:** See " [Base Station/Mobile Station State](#) " on page 38

---

**[ :SOURce<hw>]:BB:C2K:MSTation<st>:TPC:DATA <Data>**

Sets the data source for the power control bits of the traffic channels.

**Parameters:**

<Data> ZERO | ONE | PATtern | DLISt

**DLISt**

A data list is used. The data list is selected with the command  
[\[:SOURce<hw>\]:BB:C2K:MSTation<st>:TPC:DATA:DSElect](#).

**ZERO | ONE**

Internal 0 and 1 data is used.

**PATtern**

Internal data is used. The bit pattern for the data is defined by the command `[ :SOURce<hw> ] :BB:C2K:MSTation<st> :TPC:DATA:PATtern`. The maximum length is 64 bits.

\*RST: ZERO

**Example:**

```
BB:C2K:MST2:TPC:DATA PATT
```

Selects Pattern data source for the power control bits. The bit pattern is defined with the following command.

```
BB:C2K:MST2:TPC:DATA:PATT #H3F,8
```

Defines the bit pattern.

**Manual operation:** See " [Data Source \(Power Control\) - MS](#) " on page 72

**[ :SOURce<hw> ] :BB:C2K:MSTation<st> :TPC:DATA:DSElect <DSelect>**

The command selects the data list for the DLIS data source selection.

The lists are stored as files with the fixed file extensions `*.dm_iqd` in a directory of the user's choice. The directory applicable to the following commands is defined with the command `MMEMoRY:CDIR`. To access the files in this directory, you only have to give the file name, without the path and the file extension.

**Parameters:**

<DSelect> <data list name>

**Example:**

```
BB:C2K:MST2:TPC:DATA DLIS
```

selects the DLIS data source.

```
MMEMoRY:CDIR "/var/user/temp/Lists"
```

selects the directory for the data lists.

```
BB:C2K:MST2:TPC:DATA:DSEL 'cdma_ch4'
```

'selects the file "cdma\_ch4" as the data source. This file must be in specified directory and it must have the file extension `*.dm_iqd`.

**Manual operation:** See " [Data Source \(Power Control\) - MS](#) " on page 72

**[ :SOURce<hw> ] :BB:C2K:MSTation<st> :TPC:DATA:PATtern <Pattern>, <BitCount>**

Sets the bit pattern for the PATtern selection.

**Parameters:**

<Pattern> numeric

\*RST: #H0

<BitCount> integer

Range: 1 to 64

\*RST: 1

**Example:**

```
BB:C2K:MST2:TPC:DATA:PATT #H3F,8
```

defines the bit pattern for the power control-bits.

**Manual operation:** See " [Data Source \(Power Control\) - MS](#) " on page 72

**[ :SOURce<hw>]:BB:C2K:MSTation<st>:TPC:MISuse <MisUse>**

The command activates/deactivates the use of the power control data for controlling the mobile station output power. On the uplink, the power control bits are used exclusively for controlling the mobile station output power. Power control puncturing is not defined for controlling the base station power.

The bit pattern (see commands `:BB:C2K:MSTation<n>:TPC...`) of the power control bits `w` is used to control the channel power. A "1" leads to an increase of channel powers, a "0" to a reduction of channel powers. Channel power is limited to the range 0 dB to -80 dB. The step width of the change is defined with the command `[ :SOURce<hw>]:BB:C2K:MSTation<st>:TPC:PSTep`.

**Parameters:**

<MisUse>            0 | 1 | OFF | ON  
\*RST:                OFF

**Example:**

`BB:C2K:MST2:TPC:MIS ON`  
activates regulation of channel power for mobile station 2 via the power control bit pattern.  
`BB:C2K:MST2:TPC:PST 1 dB`  
sets the step width for the change of channel powers to 1 dB.

**Manual operation:** See "[For Output Power Control - MS](#)" on page 73

**[ :SOURce<hw>]:BB:C2K:MSTation<st>:TPC:PSTep <PStep>**

The command defines the step width for the change of channel powers in the case of "mis-" use of the power control bits.

**Parameters:**

<PStep>             float  
Range:               -10 to 10 dB  
Increment:          0.01 dB  
\*RST:                0 dB

**Example:**

`BB:C2K:MST2:TPC:PST 0.1 dB`  
sets the step width for the change of channel powers to 1 dB.

**Manual operation:** See "[Power Step - MS](#)" on page 74

**[ :SOURce<hw>]:BB:C2K:MSTation<st>:TPC:READ <Read>**

The command sets the read out mode for the bit pattern of the power control bits.

The bit pattern is defined with the commands `:BB:C2K:MST<n>:TPC...`

**Parameters:**

<Read>              CONTinuous | S0A | S1A | S01A | S10A

**CONTinuous**

The bit pattern is used cyclically.

**S0A**

The bit pattern is used once, then the power control bit sequence continues with 0 bits.

**S1A**

The bit pattern is used once, then the power control bit sequence continues with 1 bit.

**S01A**

The bit pattern is used once and then the power control bit sequence is continued with 0 bits and 1 bit alternately.

**S10A**

The bit pattern is used once and then the power control bit sequence is continued with 1 bit and 0 bits alternately.

\*RST: CONTInuous

**Example:**

BB:C2K:MST2:TPC:READ S0A

The bit pattern is used once, after which a 0 sequence is generated (applies to R-DCCH of mobile station 2).

**Manual operation:** See "[Read Out Mode \(Power Control\) - MS](#)" on page 72

## List of commands

[:SOURce]:BB:C2K:VERSion?	90
[:SOURce<hw>]:BB:C2K:BSTation:PRESet	109
[:SOURce<hw>]:BB:C2K:BSTation:SYNC:CNUMBER	109
[:SOURce<hw>]:BB:C2K:BSTation:SYNC:LCState	109
[:SOURce<hw>]:BB:C2K:BSTation:SYNC:MPRev	110
[:SOURce<hw>]:BB:C2K:BSTation:SYNC:NID	110
[:SOURce<hw>]:BB:C2K:BSTation:SYNC:PREV	110
[:SOURce<hw>]:BB:C2K:BSTation:SYNC:SID	111
[:SOURce<hw>]:BB:C2K:BSTation:SYNC:STIME	111
[:SOURce<hw>]:BB:C2K:BSTation<st>:CGROUP<di0>:COFFset<ch>:CCODing:BINTerleaver?	112
[:SOURce<hw>]:BB:C2K:BSTation<st>:CGROUP<di0>:COFFset<ch>:CCODing:BITFrame?	112
[:SOURce<hw>]:BB:C2K:BSTation<st>:CGROUP<di0>:COFFset<ch>:CCODing:CRc?	113
[:SOURce<hw>]:BB:C2K:BSTation<st>:CGROUP<di0>:COFFset<ch>:CCODing:DATA:RATE?	113
[:SOURce<hw>]:BB:C2K:BSTation<st>:CGROUP<di0>:COFFset<ch>:CCODing:MODE	114
[:SOURce<hw>]:BB:C2K:BSTation<st>:CGROUP<di0>:COFFset<ch>:CCODing:SPUNcture?	114
[:SOURce<hw>]:BB:C2K:BSTation<st>:CGROUP<di0>:COFFset<ch>:CCODing:SREPetition?	115
[:SOURce<hw>]:BB:C2K:BSTation<st>:CGROUP<di0>:COFFset<ch>:CCODing:TYPE	115
[:SOURce<hw>]:BB:C2K:BSTation<st>:CGROUP<di0>:COFFset<ch>:DATA	116
[:SOURce<hw>]:BB:C2K:BSTation<st>:CGROUP<di0>:COFFset<ch>:DATA:DSElect	117
[:SOURce<hw>]:BB:C2K:BSTation<st>:CGROUP<di0>:COFFset<ch>:DATA:PATtern	117
[:SOURce<hw>]:BB:C2K:BSTation<st>:CGROUP<di0>:COFFset<ch>:DATA:RATE	118
[:SOURce<hw>]:BB:C2K:BSTation<st>:CGROUP<di0>:COFFset<ch>:FLENgth	118
[:SOURce<hw>]:BB:C2K:BSTation<st>:CGROUP<di0>:COFFset<ch>:LCMask	119
[:SOURce<hw>]:BB:C2K:BSTation<st>:CGROUP<di0>:COFFset<ch>:POWer	119
[:SOURce<hw>]:BB:C2K:BSTation<st>:CGROUP<di0>:COFFset<ch>:QWCode:STATE	120
[:SOURce<hw>]:BB:C2K:BSTation<st>:CGROUP<di0>:COFFset<ch>:STATE	120
[:SOURce<hw>]:BB:C2K:BSTation<st>:CGROUP<di0>:COFFset<ch>:TPC:DATA	120
[:SOURce<hw>]:BB:C2K:BSTation<st>:CGROUP<di0>:COFFset<ch>:TPC:DATA:DSElect	121
[:SOURce<hw>]:BB:C2K:BSTation<st>:CGROUP<di0>:COFFset<ch>:TPC:DATA:PATtern	122
[:SOURce<hw>]:BB:C2K:BSTation<st>:CGROUP<di0>:COFFset<ch>:TPC:MISuse	122
[:SOURce<hw>]:BB:C2K:BSTation<st>:CGROUP<di0>:COFFset<ch>:TPC:PSTep	123
[:SOURce<hw>]:BB:C2K:BSTation<st>:CGROUP<di0>:COFFset<ch>:TPC:READ	124
[:SOURce<hw>]:BB:C2K:BSTation<st>:CGROUP<di0>:COFFset<ch>:TYPE?	124
[:SOURce<hw>]:BB:C2K:BSTation<st>:CGROUP<di0>:COFFset<ch>:WCODE	125
[:SOURce<hw>]:BB:C2K:BSTation<st>:CGROUP<di0>:COFFset<ch>:WLENgth?	125
[:SOURce<hw>]:BB:C2K:BSTation<st>:CGROUP<di0>:RCONfiguration	126
[:SOURce<hw>]:BB:C2K:BSTation<st>:DCONflict:MODE	126
[:SOURce<hw>]:BB:C2K:BSTation<st>:DCONflict:RESolve	127
[:SOURce<hw>]:BB:C2K:BSTation<st>:DCONflict[:STATE]?	127
[:SOURce<hw>]:BB:C2K:BSTation<st>:PDCHannel:PINTEval	127
[:SOURce<hw>]:BB:C2K:BSTation<st>:PDCHannel:PSETup	128
[:SOURce<hw>]:BB:C2K:BSTation<st>:PDCHannel:SUBPacket<di>:ID	128
[:SOURce<hw>]:BB:C2K:BSTation<st>:PDCHannel:SUBPacket<di>:PARAmeters	128
[:SOURce<hw>]:BB:C2K:BSTation<st>:PDCHannel:SUBPacket<di>:STATE	133
[:SOURce<hw>]:BB:C2K:BSTation<st>:PDCHannel:SUBPacket<di>:TOFFset	133
[:SOURce<hw>]:BB:C2K:BSTation<st>:PDCHannel:SUBPacket<di>:WCODes?	134
[:SOURce<hw>]:BB:C2K:BSTation<st>:PDCHannel:WINDex	134

[:SOURce<hw>]:BB:C2K:BSTation<st>:PNOFset.....	135
[:SOURce<hw>]:BB:C2K:BSTation<st>:QWSet.....	135
[:SOURce<hw>]:BB:C2K:BSTation<st>:STATe.....	135
[:SOURce<hw>]:BB:C2K:BSTation<st>:TDElay.....	135
[:SOURce<hw>]:BB:C2K:BSTation<st>:TDIVersity.....	136
[:SOURce<hw>]:BB:C2K:BSTation<st>:TDIVersity:MODE.....	136
[:SOURce<hw>]:BB:C2K:CLIPping:LEVel.....	94
[:SOURce<hw>]:BB:C2K:CLIPping:MODE.....	94
[:SOURce<hw>]:BB:C2K:CLIPping:STATe.....	95
[:SOURce<hw>]:BB:C2K:CLOCK:MODE.....	101
[:SOURce<hw>]:BB:C2K:CLOCK:SOURce.....	102
[:SOURce<hw>]:BB:C2K:COPY:COFFset.....	84
[:SOURce<hw>]:BB:C2K:COPY:DESTination.....	85
[:SOURce<hw>]:BB:C2K:COPY:EXECute.....	85
[:SOURce<hw>]:BB:C2K:COPY:SOURce.....	85
[:SOURce<hw>]:BB:C2K:CRAtE:VARiation.....	86
[:SOURce<hw>]:BB:C2K:CRAtE?.....	86
[:SOURce<hw>]:BB:C2K:FILTer:PARAmeter:APCO25.....	91
[:SOURce<hw>]:BB:C2K:FILTer:PARAmeter:COSSine.....	91
[:SOURce<hw>]:BB:C2K:FILTer:PARAmeter:GAUSS.....	92
[:SOURce<hw>]:BB:C2K:FILTer:PARAmeter:LPASS.....	92
[:SOURce<hw>]:BB:C2K:FILTer:PARAmeter:LPASSEVM.....	92
[:SOURce<hw>]:BB:C2K:FILTer:PARAmeter:PGAuss.....	93
[:SOURce<hw>]:BB:C2K:FILTer:PARAmeter:RCOSSine.....	93
[:SOURce<hw>]:BB:C2K:FILTer:PARAmeter:SPHase.....	93
[:SOURce<hw>]:BB:C2K:FILTer:TYPE.....	91
[:SOURce<hw>]:BB:C2K:IQSWap[STATe].....	87
[:SOURce<hw>]:BB:C2K:LINK.....	87
[:SOURce<hw>]:BB:C2K:MSTation:ADDITIONal:COUNT.....	138
[:SOURce<hw>]:BB:C2K:MSTation:ADDITIONal:LCMask:STEP.....	138
[:SOURce<hw>]:BB:C2K:MSTation:ADDITIONal:POWER:OFFSet.....	138
[:SOURce<hw>]:BB:C2K:MSTation:ADDITIONal:STATe.....	139
[:SOURce<hw>]:BB:C2K:MSTation:ADDITIONal:TDElay:STEP.....	139
[:SOURce<hw>]:BB:C2K:MSTation:PRESet.....	139
[:SOURce<hw>]:BB:C2K:MSTation<st>:CCODing:MODE.....	140
[:SOURce<hw>]:BB:C2K:MSTation<st>:CHANnel<ch>:DATA.....	140
[:SOURce<hw>]:BB:C2K:MSTation<st>:CHANnel<ch>:DATA:DSElect.....	141
[:SOURce<hw>]:BB:C2K:MSTation<st>:CHANnel<ch>:DATA:PATtern.....	141
[:SOURce<hw>]:BB:C2K:MSTation<st>:CHANnel<ch>:DATA:RATE.....	142
[:SOURce<hw>]:BB:C2K:MSTation<st>:CHANnel<ch>:FLEngth.....	142
[:SOURce<hw>]:BB:C2K:MSTation<st>:CHANnel<ch>:POWER.....	143
[:SOURce<hw>]:BB:C2K:MSTation<st>:CHANnel<ch>:SPReading?.....	143
[:SOURce<hw>]:BB:C2K:MSTation<st>:CHANnel<ch>:STATe.....	143
[:SOURce<hw>]:BB:C2K:MSTation<st>:CHANnel<ch>:TYPE?.....	144
[:SOURce<hw>]:BB:C2K:MSTation<st>:CHANnel<ch>:WCODE?.....	144
[:SOURce<hw>]:BB:C2K:MSTation<st>:LCMask.....	145
[:SOURce<hw>]:BB:C2K:MSTation<st>:MODE.....	145
[:SOURce<hw>]:BB:C2K:MSTation<st>:RCONfiguration.....	146
[:SOURce<hw>]:BB:C2K:MSTation<st>:STATe.....	146
[:SOURce<hw>]:BB:C2K:MSTation<st>:TPC:DATA.....	146

[:SOURce<hw>]:BB:C2K:MSTation<st>:TPC:DATA:DSElect.....	147
[:SOURce<hw>]:BB:C2K:MSTation<st>:TPC:DATA:PATtern.....	147
[:SOURce<hw>]:BB:C2K:MSTation<st>:TPC:MISuse.....	148
[:SOURce<hw>]:BB:C2K:MSTation<st>:TPC:PSStep.....	148
[:SOURce<hw>]:BB:C2K:MSTation<st>:TPC:READ.....	148
[:SOURce<hw>]:BB:C2K:POWer:ADJust.....	87
[:SOURce<hw>]:BB:C2K:POWer[:TOTal]?.....	87
[:SOURce<hw>]:BB:C2K:PPARameter:CRESt.....	102
[:SOURce<hw>]:BB:C2K:PPARameter:EXECute.....	103
[:SOURce<hw>]:BB:C2K:PPARameter:PCHannel[:STATe].....	103
[:SOURce<hw>]:BB:C2K:PPARameter:PICHannel[:STATe].....	104
[:SOURce<hw>]:BB:C2K:PPARameter:RCONfiguration.....	104
[:SOURce<hw>]:BB:C2K:PPARameter:SCHannel[:STATe].....	104
[:SOURce<hw>]:BB:C2K:PPARameter:TCHannel:COUNT.....	104
[:SOURce<hw>]:BB:C2K:PPARameter:TCHannel:DATA:RATE.....	105
[:SOURce<hw>]:BB:C2K:PPARameter:TCHannel:DCCHannel[:STATe].....	105
[:SOURce<hw>]:BB:C2K:PPARameter:TCHannel:FCHannel[:STATe].....	106
[:SOURce<hw>]:BB:C2K:PPARameter:TCHannel:FLENgth.....	106
[:SOURce<hw>]:BB:C2K:PPARameter:TCHannel:SCHannel:COUNT.....	106
[:SOURce<hw>]:BB:C2K:PRESet.....	88
[:SOURce<hw>]:BB:C2K:SETTing:CATalog?.....	88
[:SOURce<hw>]:BB:C2K:SETTing:DELeTe.....	88
[:SOURce<hw>]:BB:C2K:SETTing:LOAD.....	89
[:SOURce<hw>]:BB:C2K:SETTing:STORe.....	89
[:SOURce<hw>]:BB:C2K:SLENgth.....	89
[:SOURce<hw>]:BB:C2K:STATe.....	90
[:SOURce<hw>]:BB:C2K:TRIGger:ARM:EXECute.....	97
[:SOURce<hw>]:BB:C2K:TRIGger:EXECute.....	97
[:SOURce<hw>]:BB:C2K:TRIGger:EXTernal:SYNChronize:OUTPut.....	97
[:SOURce<hw>]:BB:C2K:TRIGger:OBASeband:DELay.....	97
[:SOURce<hw>]:BB:C2K:TRIGger:OBASeband:INHibit.....	98
[:SOURce<hw>]:BB:C2K:TRIGger:OUTPut<ch>:DELay.....	101
[:SOURce<hw>]:BB:C2K:TRIGger:OUTPut<ch>:MODE.....	99
[:SOURce<hw>]:BB:C2K:TRIGger:OUTPut<ch>:OFFTime.....	100
[:SOURce<hw>]:BB:C2K:TRIGger:OUTPut<ch>:ONTime.....	100
[:SOURce<hw>]:BB:C2K:TRIGger:OUTPut<ch>:PERiod.....	100
[:SOURce<hw>]:BB:C2K:TRIGger:RMODE?.....	98
[:SOURce<hw>]:BB:C2K:TRIGger:SLENgth.....	99
[:SOURce<hw>]:BB:C2K:TRIGger:SLUNit.....	99
[:SOURce<hw>]:BB:C2K:TRIGger:SOURce.....	96
[:SOURce<hw>]:BB:C2K:TRIGger[:EXTernal]:DELay.....	98
[:SOURce<hw>]:BB:C2K:TRIGger[:EXTernal]:INHibit.....	98
[:SOURce<hw>]:BB:C2K:WAVEform:CREate.....	90
[:SOURce<hw>]:BB:C2K[:TRIGger]:SEQuence.....	96

# Index

## Symbols

(Mis-) use for output power control - BS ..... 59, 122  
 (Mis-) use for output power control - MS ..... 148

## A

Accept - Copy ..... 85  
 Accept - predefined settings ..... 41  
 Accept - Predefined Settings ..... 103  
 Access ..... 70  
 Additional MS ..... 42, 139  
 Adjust total Power to 0 dB ..... 37  
 Application cards ..... 9  
 Application notes ..... 9  
 Arm ..... 28  
 Armed\_Auto ..... 27  
 Armed\_Retrigger ..... 27  
 Auto ..... 27

## B

B x T ..... 79  
 Base station default values ..... 35  
 Baseband Clipping ..... 80  
 Baseband filter ..... 79, 91  
 Bit reversed ..... 55, 126  
 Block interleaver - BS ..... 63  
 Block Interleaver - BS ..... 112  
 Brochures ..... 9

## C

CDMA channel number ..... 64  
 CDMA Channel Number - BS ..... 109  
 CDMA Version ..... 90  
 Channel Coding Mode - BS ..... 61  
 Channel Coding Mode - MS ..... 71  
 Channel number ..... 46  
 Channel Number- MS ..... 75  
 Channel Power ..... 50  
 Channel Power - MS ..... 77  
 Channel state ..... 51  
 Channel state - MS ..... 78  
 Channel State - MS ..... 143  
 Channel Type ..... 47  
 Channel Type - MS ..... 75, 144  
 Chip rate variation ..... 79  
 Clipping Level ..... 80, 94  
 Clipping Mode ..... 80, 94  
 Clipping state ..... 80  
 Clock Mode ..... 33  
 Clock Source ..... 33  
 Code domain ..... 51  
 Code domain - BS ..... 54  
 Code domain conflict ..... 51  
 Code domain conflict - BS ..... 51  
 Code Domain Conflict - BS ..... 127  
 Coder Type ..... 61  
 Coder Type - BS ..... 115  
 Common control ..... 70  
 Common trigger settings ..... 27  
 Conventions  
   SCPI commands ..... 83

Convolution coder ..... 61  
 Convolution Code - BS ..... 115  
 Copy Base Station ..... 36, 85  
 Copy from Source ..... 36, 85  
 Copy Mobile Station ..... 36, 85  
 Coupled trigger settings ..... 27  
 CRC Length - BS ..... 62  
 Crest factor ..... 80  
 Crest factor - Clipping ..... 94  
 Crest Factor, desired range ..... 39  
 Cutoff Frequency factor ..... 79

## D

Data pattern ..... 50  
   MS ..... 77  
 Data Rate ..... 49  
 Data Rate - BS ..... 118  
 Data Rate - MS ..... 76, 142  
 Data Rate - predefined settings ..... 41  
 Data Rate - Predefined Settings ..... 105  
 Data sheets ..... 9  
 Data source  
   BS ..... 50  
   MS ..... 77  
   Power control ..... 72  
   Power Control ..... 58  
 Default settings ..... 24, 35  
 Default values MS ..... 36  
 Delay  
   Marker ..... 32  
   Trigger ..... 30  
 Diversity Mode- BS ..... 44, 136  
 Do Conf - BS ..... 127  
 Documentation overview ..... 8  
 Downlink ..... 25

## E

Effective Data Rate - BS ..... 63, 113  
 Enhanced access ..... 70  
 Error Protection ..... 61  
 Error Protection - BS ..... 115  
 External trigger  
   Delay ..... 30

## F

Filter parameter ..... 79  
 Filter Type ..... 79, 91  
 Filtering, Clipping, ARB Settings ..... 78  
 For output power control - MS ..... 73  
 Frame Length ..... 49  
 Frame Length - MS ..... 76, 142  
 Frame Length - predefined settings ..... 41

## G

Generate  
   Waveform file ..... 25  
 Getting started ..... 8

**H**

Hadamard .....	55, 126
Help .....	8

**I**

I/Q swap .....	82
I/Q-Swap .....	87
Installation .....	7
Instrument help .....	8
Instrument security procedures .....	9
Invert Q for correct Baseband Output .....	82
Invert Q for Correct Baseband Output .....	87

**L**

LC Mask .....	57, 71
LC Mask Step - additional MS .....	42
LC state (hex) - BS .....	64
Link Direction .....	25, 87

**M**

Marker Delay .....	32
Marker Mode .....	31
Marker Period .....	31
Measured external clock .....	33
Minimum protocol revision level .....	64
Mobile station default values .....	36
Modulation .....	68
Modulation data	
BS .....	50
More parameters	
BS channel table .....	56
More Params F-PDCH .....	65

**N**

Network identification .....	65
Number of 32-Chip Walsh Channels - BS .....	68
Number of additional MS .....	42
Number of bits per Encoder Packet .....	68
Number of Slots per subpacket .....	68
Number of Supplemental Channels - Predef .....	40
Number of Traffic Channels - Predef .....	40, 104
Nyquist filter .....	79, 91

**O**

ON/OFF Ratio Marker .....	31
Open source acknowledgment (OSA) .....	9
Operation mode .....	70
Order code domain - BS .....	55
Order Code Domain - BS .....	126

**P**

Packet interval - BS .....	66
Packet Interval - BS .....	127
Packet Setup - BS .....	66
PN Offset - BS .....	45, 135
Power Offset - additional MS .....	43
Power Offset - Additional MS .....	138
Power step - BS .....	60
Power Step - BS .....	123
Power step - MS .....	74
Power Step - MS .....	148

Power/dB .....	50
Power/dB - MS .....	77
Protocol revision level .....	64
Protocol Revision Level - BS .....	110

**Q**

Quasi Orthogonal Walsh Set - BS .....	45, 135
Quasi-orthogonal Walsh code .....	50

**R**

Radio configuration .....	39
Radio Configuration .....	48
Radio Configuration - MS .....	71, 146
Raised cosine filter	
see Cosine filter .....	79
Read out mode .....	59
Read out mode - MS .....	72
Release notes .....	9
Reset all Base Stations .....	35
Reset all Mobile Stations .....	36
Resulting Walsh code for subpacket - BS .....	69
Resulting Walsh Code for Subpacket - BS .....	134
Retrigger .....	27
Roll Off .....	79
Root raised cosine filter	
see Root Cosine .....	79
RRC filter	
see Root Cosine filter .....	79

**S**

Safety instructions .....	9
Same Packet Setup - BS .....	66
Save/Recall	
CDMA2000 .....	25
Security procedures .....	9
Select Base Station .....	37
Select Mobile Station .....	37
Sequence Length (ARB) .....	81
Service manual .....	8
Set to default .....	24
Signal duration unit .....	28
Signal generation status .....	28
Single .....	27
Source bits / Frame - BS .....	62
Spread - MS .....	77
Spreading code number .....	49
Spreading Rate .....	25, 86
Standard settings .....	24
State	
Clipping .....	95
State - BS .....	135
State - MS .....	70, 146
Subpacket # .....	67
Subpacket Data Rate - BS .....	68
Subpacket ID - BS .....	67, 128
Subpacket state - BS .....	67
Subpacket State - BS .....	133
Symbol puncture - BS .....	62
Symbol Puncture - BS .....	114
Symbol repetition - BS .....	62
System identification .....	65
System Identification - BS .....	111
System Time - BS .....	64

**T**

Time Delay - BS .....	44
Time delay step - additional MS .....	43
Time Slot Offset - BS .....	67
To destination .....	36
To Destination .....	85
Total Power .....	37, 87
Traffic .....	70
Transmission direction .....	25, 87
Transmit Diversity - BS .....	44
Transmit Diversity Mode - BS .....	44, 136
Trigger	
Sync. output .....	29
Trigger delay .....	30
Trigger mode .....	27
Trigger signal duration .....	28
Trigger source .....	28
Turbo coder .....	61
Turbo Coder - BS .....	115
Tutorials .....	8

**U**

Uplink .....	25
Use Dedicated Control (F-DCCH) - Predef .....	40
Use Fundamental (F-FCH) - Predef .....	40
Use paging channel (F-PCH) - Predef .....	39
Use Paging Channel (F-PCH) - Predef .....	103
Use pilot (F-PICH) - Predef .....	39
Use Pilot (F-Pich) - Predef .....	104
Use Sync (F-Sync) - Predef .....	39
User manual .....	8
User Period .....	31

**V**

Version .....	25, 90
---------------	--------

**W**

Walsh - MS .....	76
Walsh code .....	49
Walsh code column index - BS .....	66
Walsh Code Column Index - BS .....	134
Walsh code Offset .....	36
Walsh Code Offset .....	84
Walsh Length - BS .....	57
Waveform file	
Create .....	25
White papers .....	9