

R&S[®]SMCVB-K168

DVB-S2

User Manual



1179106402
Version 03

ROHDE & SCHWARZ
Make ideas real



This document describes the following software option:

- R&S®SMCVB-K168 DVB-S2x (1434.3919.xx)

This manual describes firmware version FW 4.90.002.xx and later of the R&S®SMCV100B.

© 2021 Rohde & Schwarz GmbH & Co. KG

Mühlhofstr. 15, 81671 München, Germany

Phone: +49 89 41 29 - 0

Email: info@rohde-schwarz.com

Internet: www.rohde-schwarz.com

Subject to change – data without tolerance limits is not binding.

R&S® is a registered trademark of Rohde & Schwarz GmbH & Co. KG.

Trade names are trademarks of the owners.

1179.1064.02 | Version 03 | R&S®SMCVB-K168

The following abbreviations are used throughout this manual: R&S®SMCV100B is abbreviated as R&S SMCVB, R&S®WinIQSIM2 is abbreviated as R&S WinIQSIM2

Contents

1	Welcome to the DVB-S2x Option.....	5
1.1	Accessing the DVB-S2x Dialog.....	5
1.2	Documentation Overview.....	5
1.2.1	Getting Started Manual.....	5
1.2.2	User Manuals and Help.....	6
1.2.3	Service Manual.....	6
1.2.4	Instrument Security Procedures.....	6
1.2.5	Printed Safety Instructions.....	6
1.2.6	Data Sheets and Brochures.....	6
1.2.7	Release Notes and Open Source Acknowledgment (OSA).....	7
1.2.8	Application Notes, Application Cards, White Papers, etc.....	7
1.3	Scope.....	7
1.4	Notes on Screenshots.....	7
2	About the DVB-S2x Option.....	9
2.1	Required Options.....	9
3	DVB-S2 Configuration and Settings.....	10
3.1	General Settings.....	10
3.2	Input Signal Settings.....	15
3.2.1	General Settings.....	16
3.2.2	Info.....	18
3.2.3	Test Signal Settings.....	20
3.2.4	IP Channel x Settings.....	22
3.3	Coding Settings.....	25
3.3.1	General Settings.....	26
3.3.2	IS1/TSL1 Settings.....	29
3.3.3	IS 2 - x Settings.....	35
3.3.4	TSL 2 - x Settings.....	36
3.4	Special Settings.....	37
3.5	Global Connector Settings.....	39
3.6	TS Player.....	39
3.6.1	TS Player Settings.....	40

3.6.2	Player Output Settings.....	43
3.6.2.1	General Settings.....	44
3.6.2.2	Stuffing Settings.....	45
3.6.3	Seamless Loop Settings.....	47
3.7	Local IP Data Network Settings.....	48
4	Performing DVB-S2x Signal Generation Tasks.....	51
4.1	Configuring the Input Signal.....	51
4.1.1	How to Apply an External IP Input Signal.....	51
4.1.2	How to Apply an External TS Input Signal.....	54
4.1.3	How to Generate an Internal TS Signal.....	55
4.2	Monitoring the Input Signal.....	56
4.2.1	How to Monitor External IP Input Data.....	56
4.2.2	How to Monitor an External TS Input Signal.....	57
4.2.3	How to Monitor an Internal TS Player Signal.....	57
5	Remote-Control Commands.....	58
5.1	General Commands.....	59
5.2	Input Commands.....	61
5.2.1	General Commands.....	61
5.2.2	Info Commands.....	62
5.2.3	Test Signal Commands.....	64
5.2.4	IP Subsystem.....	65
5.3	Coding Commands.....	69
5.3.1	General Commands.....	69
5.3.2	TSL Commands.....	70
5.4	Special Commands.....	72
5.5	TSGen Subsystem.....	73
5.6	BCIP Subsystem.....	81
	Glossary: Abbreviations.....	85
	Glossary: Specifications.....	87
	List of commands.....	88
	Index.....	90

1 Welcome to the DVB-S2x Option

The R&S SMCVB-K168 is a firmware application that adds functionality to generate signals in accordance with the DVB-S2x digital standard.

The R&S SMCVB-K168 option features:

- DVB-S2 signal generation
- DVB-S2x signal generation

This user manual contains a description of the functionality that the application provides, including remote control operation.

All functions not discussed in this manual are the same as in the base unit and are described in the R&S SMCV100B user manual. The latest version is available at:

www.rohde-schwarz.com/manual/SMCV100B

Installation

You can find detailed installation instructions in the delivery of the option or in the R&S SMCV100B service manual.

1.1 Accessing the DVB-S2x Dialog

To open the dialog with DVB-S2x settings

- ▶ In the block diagram of the R&S SMCV100B, select "Baseband > DVB-S2".

A dialog box opens that displays the provided general settings.

The signal generation is not started immediately. To start signal generation with the default settings, select "State > On".

1.2 Documentation Overview

This section provides an overview of the R&S SMCV100B user documentation. Unless specified otherwise, you find the documents on the R&S SMCV100B product page at:

www.rohde-schwarz.com/manual/smcv100b

1.2.1 Getting Started Manual

Introduces the R&S SMCV100B and describes how to set up and start working with the product. Includes basic operations, typical measurement examples, and general information, e.g. safety instructions, etc. A printed version is delivered with the instrument.

1.2.2 User Manuals and Help

Separate manuals for the base unit and the software options are provided for download:

- **Base unit manual**
Contains the description of all instrument modes and functions. It also provides an introduction to remote control, a complete description of the remote control commands with programming examples, and information on maintenance, instrument interfaces and error messages. Includes the contents of the getting started manual.
- **Software option manual**
Contains the description of the specific functions of an option. Basic information on operating the R&S SMCV100B is not included.

The contents of the user manuals are available as help in the R&S SMCV100B. The help offers quick, context-sensitive access to the complete information for the base unit and the software options.

All user manuals are also available for download or for immediate display on the Internet.

1.2.3 Service Manual

Describes the performance test for checking compliance with rated specifications, firmware update, troubleshooting, adjustments, installing options and maintenance.

The service manual is available for registered users on the global Rohde & Schwarz information system (GLORIS):

<https://gloris.rohde-schwarz.com>

1.2.4 Instrument Security Procedures

Deals with security issues when working with the R&S SMCV100B in secure areas. It is available for download on the Internet.

1.2.5 Printed Safety Instructions

Provides safety information in many languages. The printed document is delivered with the product.

1.2.6 Data Sheets and Brochures

The data sheet contains the technical specifications of the R&S SMCV100B. It also lists the options and their order numbers and optional accessories.

The brochure provides an overview of the instrument and deals with the specific characteristics.

See www.rohde-schwarz.com/brochure-datasheet/smcv100b

1.2.7 Release Notes and Open Source Acknowledgment (OSA)

The release notes list new features, improvements and known issues of the current firmware version, and describe the firmware installation.

The open-source acknowledgment document provides verbatim license texts of the used open source software.

See www.rohde-schwarz.com/firmware/smcv100b

1.2.8 Application Notes, Application Cards, White Papers, etc.

These documents deal with special applications or background information on particular topics.

See www.rohde-schwarz.com/application/smcv100b

1.3 Scope



Tasks (in manual or remote operation) that are also performed in the base unit in the same way are not described here.

In particular, it includes:

- Managing settings and data lists, like saving and loading settings, creating and accessing data lists, or accessing files in a particular directory.
- Information on regular trigger, marker and clock signals and filter settings, if appropriate.
- General instrument configuration, such as checking the system configuration, configuring networks and remote operation
- Using the common status registers

For a description of such tasks, see the R&S SMCV100B user manual.

1.4 Notes on Screenshots

When describing the functions of the product, we use sample screenshots. These screenshots are meant to illustrate as many as possible of the provided functions and possible interdependencies between parameters. The shown values may not represent realistic usage scenarios.

The screenshots usually show a fully equipped product, that is: with all options installed. Thus, some functions shown in the screenshots may not be available in your particular product configuration.

2 About the DVB-S2x Option

DVB-S2 is the second-generation [DVB](#) standards for satellite services. It has evolved from DVB-S. Comparing DVB-S2 with DVB-S at the same transponder bandwidth and [EIRP](#) shows the following. By using innovative and more efficient channel coding methods, combined with higher-order modulation modes, 30 % more data can be transmitted with DVB-S2.

DVB-S2 complies with specification [EN 302 307](#).

2.1 Required Options

The equipment layout for generating DVB-S2x signals includes:

- Base unit
- Option Enable Broadcast Standard (R&S SMCVB-K519)
- Option DVB-S / DVB-S2 (R&S SMCVB-K167)
- Option DVB-S2x (R&S SMCVB-K168)

3 DVB-S2 Configuration and Settings

Access:

- ▶ Select "Baseband > DVB-S2".

This section provides an overview on the DVB-S2x settings.

The remote commands required to define these settings are described in [Chapter 5, "Remote-Control Commands"](#), on page 58.

Settings:

- [General Settings](#)..... 10
- [Input Signal Settings](#)..... 15
- [Coding Settings](#)..... 25
- [Special Settings](#)..... 37
- [Global Connector Settings](#)..... 39
- [TS Player](#)..... 39
- [Local IP Data Network Settings](#)..... 48

3.1 General Settings

Access:

- ▶ Select "Baseband > DVB-S2".

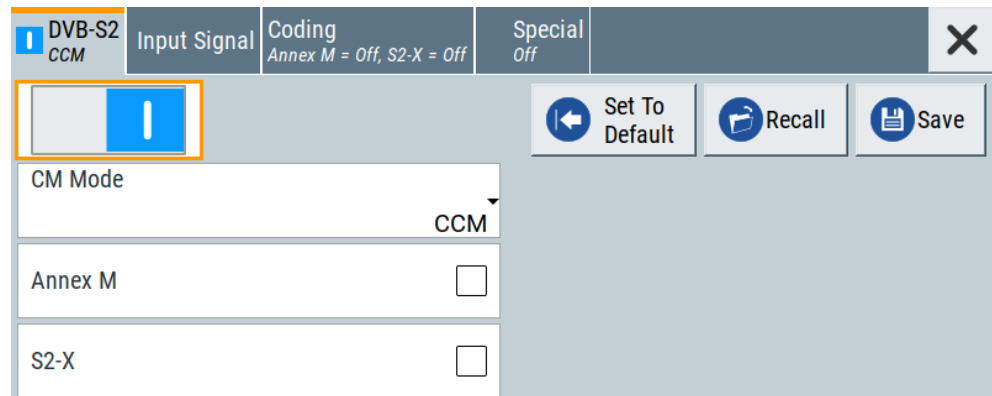

The tab provides functionality for calling default settings, save and recall settings. Also it provides settings to set coding and modulation mode, S2x operation and time-slicing as specified in annex M of specification [EN 302 307](#).

Settings:

- [State](#)..... 11
- [Set To Default](#)..... 11
- [Save/Recall](#)..... 11

CM Mode.....	11
Annex M.....	13
S2-X.....	14

State

Activates the standard and deactivates all the other digital standards and digital modulation modes in the same path.

Remote command:

`[:SOURce<hw>] :BB:DVBS2:STATe` on page 59

Set To Default

Calls the default settings. The values of the main parameters are listed in the following table.

Parameter	Value
State	Not affected by the "Set to Default"

Remote command:

`[:SOURce<hw>] :BB:DVBS2:PRESet` on page 59

Save/Recall

Accesses the "Save/Recall" dialog, that is the standard instrument function for saving and recalling the complete dialog-related settings in a file. The provided navigation possibilities in the dialog are self-explanatory.

The settings are saved in a file with predefined extension. You can define the filename and the directory, in that you want to save the file.

See also, chapter "File and Data Management" in the R&S SMCV100B user manual.

Remote command:

`[:SOURce<hw>] :BB:DVBS2:SETTing:CATalog` on page 59

`[:SOURce<hw>] :BB:DVBS2:SETTing:DELeTe` on page 59

`[:SOURce<hw>] :BB:DVBS2:SETTing:LOAD` on page 60

`[:SOURce<hw>] :BB:DVBS2:SETTing:STORe` on page 60

CM Mode

Sets the coding and modulation (CM) mode.

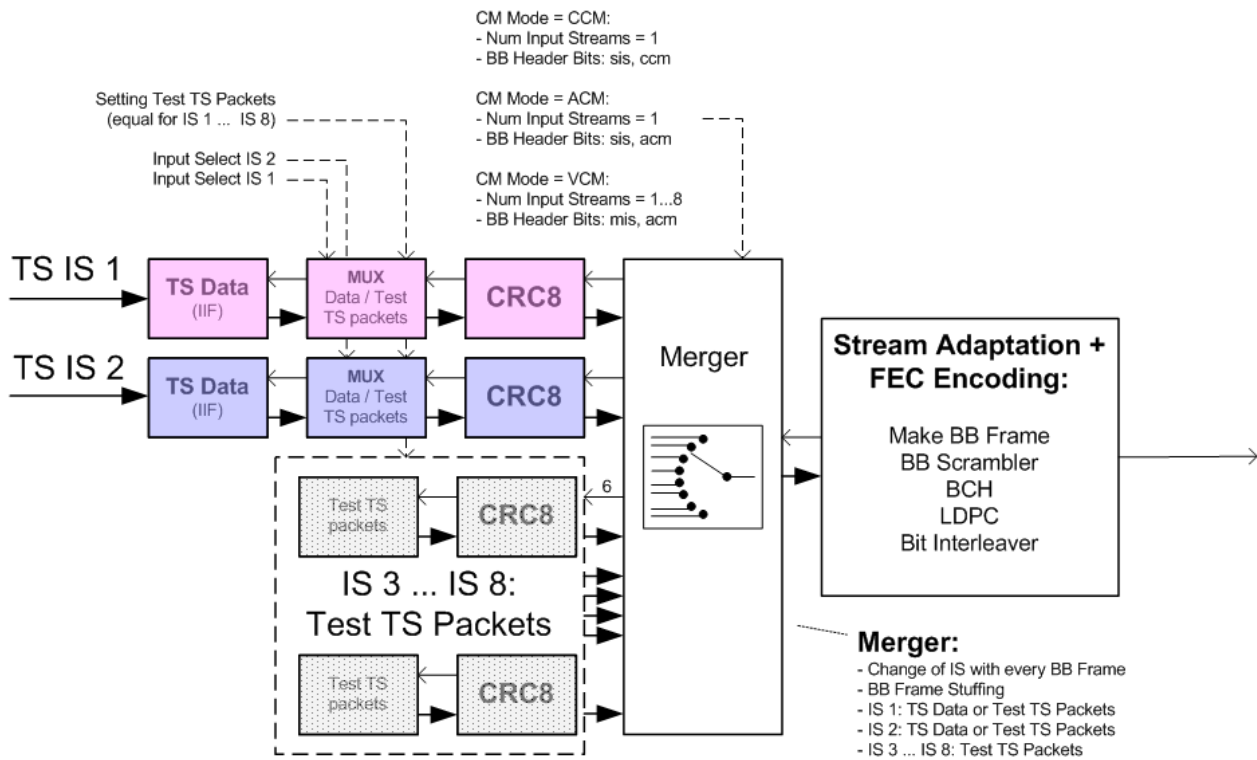

Figure 3-1: CM mode block diagram

Example: VCM merger cycle with 3 input streams

- BB frame #1: IS 1, settings of IS 1, padding to complete BB frame #1.
- BB frame #2: IS 2, settings of IS 2, padding to complete BB frame #2.
- BB frame #3: IS 3, settings of IS 3, padding to complete BB frame #3.
- BB frame #4: IS 1, (next merger cycle)

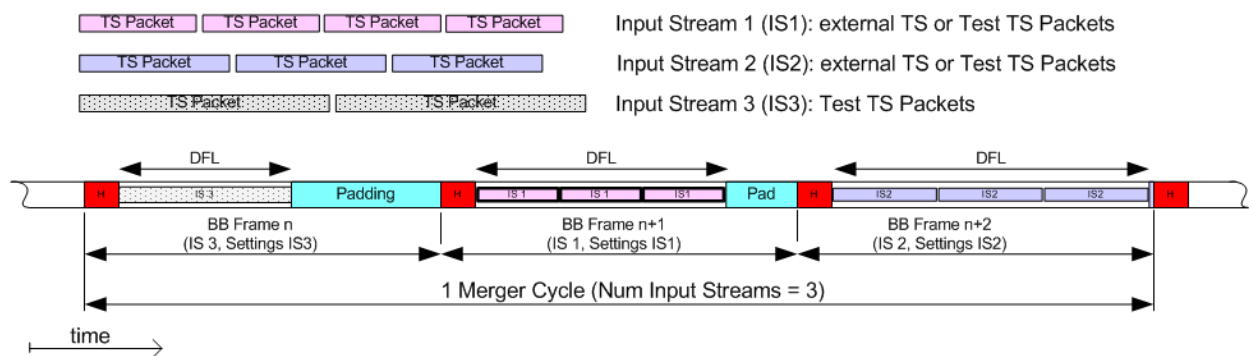

Figure 3-2: VCM multiple input stream (timing diagram)

"CCM" Constant coding and modulation (CCM). Uses one input stream. PCR correction is active.

- "ACM" Variable coding and modulation. Changes of settings are executed seamlessly at the end of a complete PL frame.
- "VCM" Enables multiple input streams (MIS). Depending on the [Num. Input Streams](#), you can set the input signal parameters individually for 2 input streams. For all other input streams, test TS packets are used. All input streams are using different PIDs for the TS test packets. Thus, you can perform a BER measurement on every input stream, if the PID filter of the BER measurement is enabled. For input stream 1, set the PID of the TS test packets, see "[PID \(Hex\)](#)" on page 21. For all subsequent input streams, the PID is derived from its predecessor by subtracting 1.

Example:

For input stream 1, set "PID > 1FFF" (0x1FFF). The PIDs of the other input streams (IS) are as follows: IS2: 0x1FFE, IS3: 0x1FFD, IS4: 0x1FFC, IS5: 0x1FFB, IS6: 0x1FFA, IS7: 0x1FF9, IS8: 0x1FF8.

After completing one BB frame, the next input stream is used to fill one BB frame.

If necessary, padding is performed to complete the BB frame. A new BB frame uses the next input stream. After the last input stream, a new merger cycle starts, and the next BB frame uses input stream 1.

Remote command:

`[:SOURCE<hw>] :BB:DVBS2 [:INPut] :CMMode` on page 61

Annex M

Enables the annex M features as specified in [EN 302 307](#). Depending on this setting, a different PL header is used.

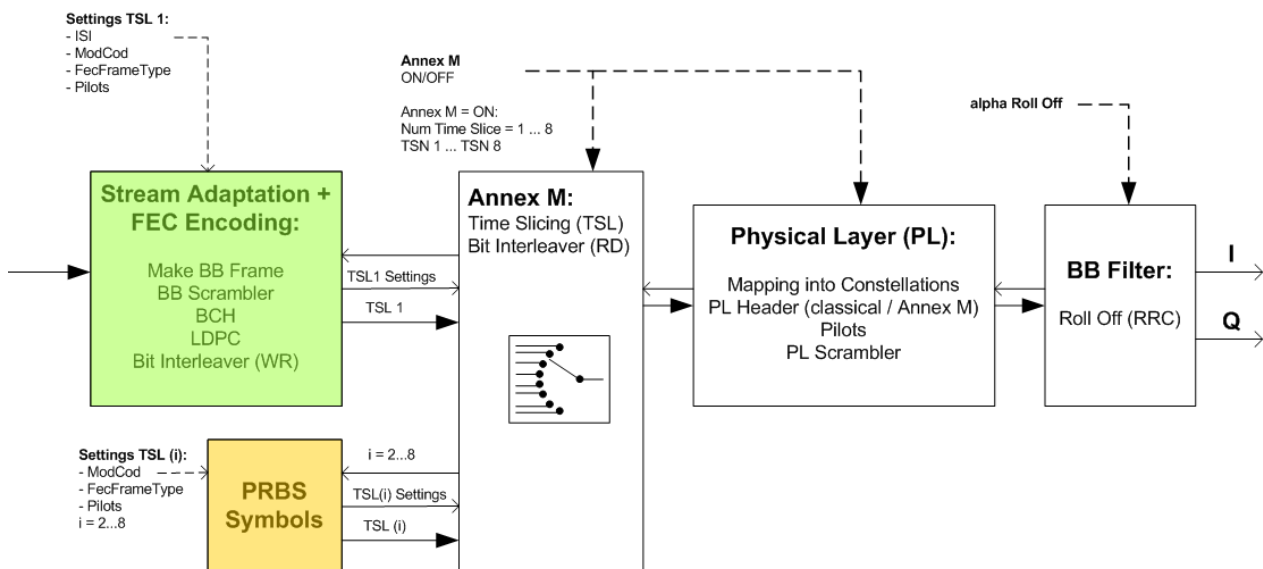

Figure 3-3: Annex M block diagram

Example: Annex M with 3 time slices

Time slice #1: TSN 1, data symbols from FEC encoding

Time slice #2: TSN 2, PRBS data symbols

Time slice #3: TSN 3, PRBS data symbols

Time slice #4: TSN 1, data symbols from FEC encoding (next time slice cycle)

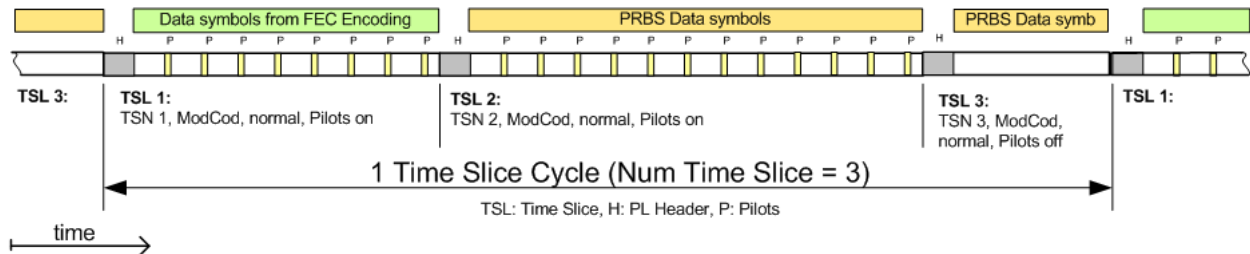

Figure 3-4: Annex M time slicing (timing diagram)

"On" Time-slicing can be activated and more modulation coding settings can be signaled.

"Off" No time-slicing.

Remote command:

[:SOURCE<hw>] :BB:DVBS2:ANNM on page 69

S2-X

Enables S2-X features.

For DVB-S2-X, additional modulation coding settings are defined to obtain a finer SNR granularity compared to classical S2 modulation coding:

- Clear sky conditions (e.g. 256 APSK)
- Linear channel models (marked with "-L")
- Very low SNR conditions (VL-SNR)
- ...

Related to a DVB-S2-X modulation coding setting is a corresponding LDPC code rate and a FEC frame type. If the order of the modulation coding is higher than QPSK, a bit interleaver pattern is related to this modulation coding setting.

Note: VL-SNR modulation coding, super frame and channel bonding are released in a later version.

Remote command:

[:SOURCE<hw>] :BB:DVBS2:S2X on page 60

3.2 Input Signal Settings

Access:

- ▶ Select "Baseband > DVB-S2 > Input Signal".

The dialog provides access to settings necessary to configure the input signal.

Input signal tasks

The settings allow you to perform the following tasks:

- Selecting an [MPEG TS](#) source
- Displaying information about the selected MPEG TS (e.g. data rate)
- Configuring the internal MPEG TS test packets or internal IP test packets
- Selecting the CM mode. If "CM Mode > VCM", you can also select the number of input streams.

How to: [Chapter 4.1, "Configuring the Input Signal"](#), on page 51.



Common input signal settings

The setting of the following parameters is used for all broadcast standards.

- "Source"
- "Input/Input Type"
- "IP TS Channel"

Settings:

• General Settings	16
• Info	18
• Test Signal Settings	20
• IP Channel x Settings	22

3.2.1 General Settings

Access:

- ▶ Select "Input Signal > General".

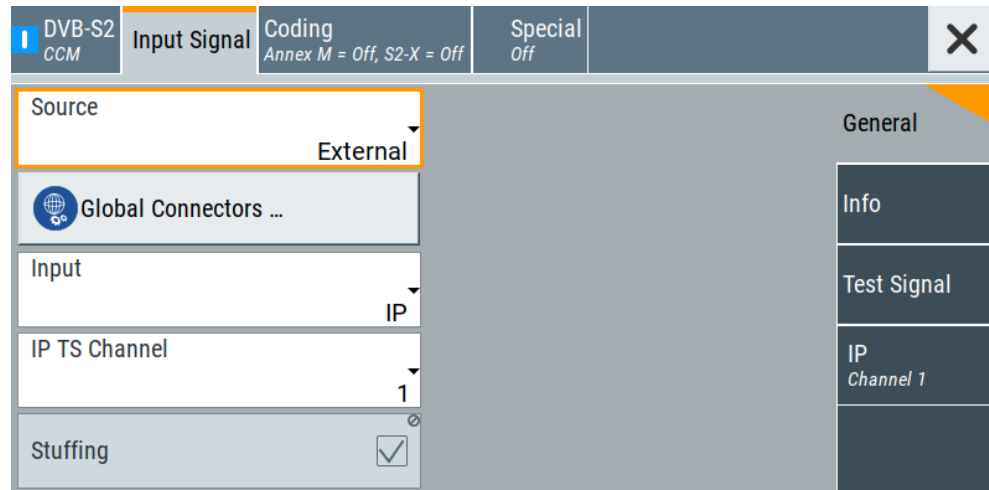

The tab provides general settings necessary to configure the input signal.

Settings:

Num. Input Streams.....	16
Source	16
Input	17
Input Format.....	17
IP TS Channel.....	17
Stuffing.....	18
Test Signal.....	18

Num. Input Streams

Requires "CM Mode > VCM".

Sets the number of input streams. Maximum 8 input streams are possible.

You can configure the first 2 input streams individually. All other input streams are using test TS packets.

Remote command:

[:SOURce<hw>] :BB:DVBS2 [:INPut] :NIS on page 61

Source

Sets the modulation source for the input signal.

Note: If "CCM > VCM", you can set this parameter for 2 input streams individually. The source of all other input streams is automatically set to "Test Signal".

- "External" Uses a transport stream, that is input at the "TS IN"/"IP Data" interface.
- For more information about connecting to the interfaces, see also:
- "TS IN" interface: Section "Configuring the Global Connectors" in the R&S SMCV100B user manual.
 - "IP Data" interface: [Chapter 3.7, "Local IP Data Network Settings"](#), on page 48.
- "TS Player" Uses an internal transport stream with TS packet data played from a file. The player requires no option. Playing encrypted files with extension `_c` requires a stream library option R&S SMCVB-KSx.
- See also:
- [Chapter 3.6, "TS Player"](#), on page 39
 - [Supported TS player file types](#)
- "Test Signal" Uses an internal test signal as specified in [Chapter 3.2.3, "Test Signal Settings"](#), on page 20.

Remote command:

`[:SOURce<hw>] :BB:DVBS2 :SOURce` on page 61

Input

Requires "Source > External".

Sets the external input interface.

- "TS IN" Input for serial transport stream data. The signal is input at the "User 1" connector.
- "IP" Input for IP-based transport stream data (TSoverIP). The signal is input at the "IP Data" connector.

Remote command:

`[:SOURce<hw>] :BB:DVBS2 :INPut [:IS<ch>]` on page 62

Input Format

Requires "Source > External" and "Input > TS IN".

Sets the format of the input signal.

- "ASI" [ASI](#) format
- "SMPTE 310" [SMPTE 310](#) format

Remote command:

`[:SOURce<hw>] :BB:DVBS2 :INPut [:IS<ch>] :FORMat` on page 62

IP TS Channel

Requires "Source > External" and "Input > IP".

Selects the IP-based transport stream (TS) channel. You can select 1 out of 4 IP TS channels as input at the "IP Data" interface.

To configure a particular channel, see [Chapter 3.2.4, "IP Channel x Settings"](#), on page 22.

Remote command:

`[:SOURce<hw>] :BB:DVBS2 :INPut [:IS<ch>] :TSCChannel` on page 62

Stuffing

Requires "Source > External/TS Player" and "CM Mode > CCM/ACM".

Activates stuffing.

"On" The installed input interface provides the transport stream data rate required for the current modulation parameters (regardless of the input data rate of the external transport stream).
The setting is fixed.

"Off" Not available if "CM Mode > VCM".
The data rate of the transport stream source must match the data rate required for the current modulation parameters.
The value equals the "[Max. Useful Data Rate](#)" on page 19.

Remote command:

[\[:SOURce<hw>\]:BB:DVBS2\[:IS<ch>\]:STUFFing](#) on page 62

Test Signal

Requires "Source > Test Signal".

Defines the test signal data.

The data consists of test [TS](#) packets.

"Test TS Packet"

Standardized packet data used as modulation data in the transport stream. To configure the packet structure, select the side tab "Test Signal > Test TS Packet".

See also "[Test TS Packet](#)" on page 21.

Remote command:

[\[:SOURce<hw>\]:BB:DVBS2\[:IS<ch>\]:TESTsignal](#) on page 64

3.2.2 Info

Access:

- ▶ Select "Input Signal > Info".

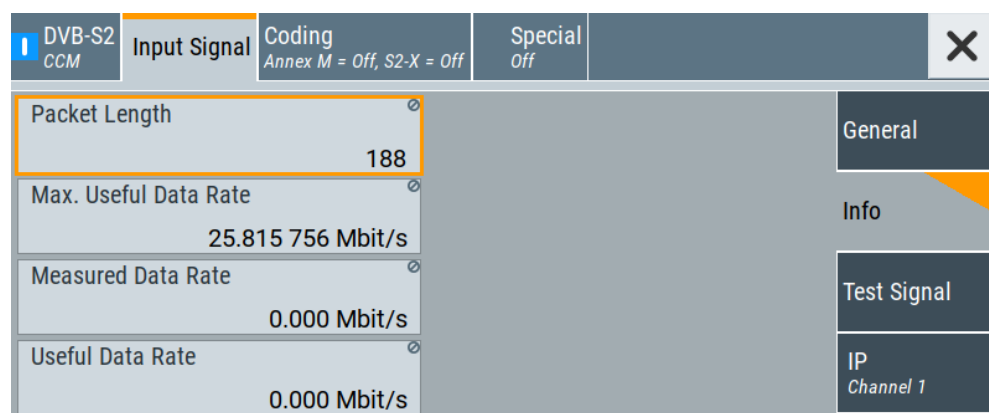

The tab displays information on the input signal.

The displayed information depends on the coding and modulation mode:

- "CM Mode > CCM/ACM": Single input stream information.
- "CM Mode > VCM": Multiple input stream information displayed in the "Input Stream <num>" table.

See "Input Stream <num> table" on page 19.

Settings:

Input Stream <num> table.....	19
L Packet Length	19
L Max. Useful Data Rate.....	19
L Measured Data Rate	20
L Useful Data Rate	20

Input Stream <num> table

Displays individual parameters for each input stream <num>. The table displays information of up to 8 input streams with <num> ranging from 1 to 8.

For 2 input streams, you can set and read the input signal parameters individually. For all other input streams, the source is fixed to "Test Signal" and only displayed in the table.

Packet Length ← Input Stream <num> table

Requires "Source > External".

Displays the packet length of the external transport stream in bytes.

If the packet length does not match the specified length, the output signal is erroneous. "Packet Length > Invalid" is displayed.

"188"	188 byte packets specified for serial input ("Input > TS IN") and parallel input ("Input > IP"). If stuffing is disabled, only this value is allowed.
"204"	204 byte packets specified for serial input and parallel input.
"Invalid"	Packet length does not match the specified length.

Remote command:

[:SOURce<hw>] :BB:DVBS2 [:IS<ch>] :PACKetlength? on page 63

Max. Useful Data Rate ← Input Stream <num> table

Requires "Source > External/TS Player".

Displays the maximum data rate, that is derived from the current modulation parameter settings.

The value is the optimal value at the TS input interface, that is necessary for the modulator.

If "Stuffing > On", the value indicates the maximum useful data rate, that is allowed in the transport stream.

If "Stuffing > Off", the value indicates the transport stream input data rate that is required for the transport stream.

Remote command:

[:SOURce<hw>] :BB:DVBS2 [:IS<ch>] :USEFul [:RATE] :MAX? on page 63

Measured Data Rate ← Input Stream <num> table

Requires "Source > External".

Displays the measured value of the data rate r_{meas} of one of the following:

- External transport stream including null packets input at "User 1" connector
- External transport stream including null packets input at "IP Data/LAN" connector (TSoverIP)

The value r_{meas} equals the sum of useful data rate r_{useful} and the rate of null packets r_0 :

If "Stuffing > Off", ensure that the measured data rate equals the maximum useful data rate ($r_{\text{meas}} = r_{\text{max. useful}}$).

Remote command:

`[:SOURce<hw>] :BB:DVBS2 [:INPut] [:IS<ch>] :DATarate?` on page 64

Useful Data Rate ← Input Stream <num> table

Requires "Source > External/TS Player".

Displays the data rate of useful data r_{useful} of the external transport stream. The data rate is measured at the input of the installed input interface.

Remote command:

`[:SOURce<hw>] :BB:DVBS2 [:IS<ch>] :USEFu1 [:RaTE]` on page 63

3.2.3 Test Signal Settings

Access:

- ▶ Select "Input Signal > Test Signal".

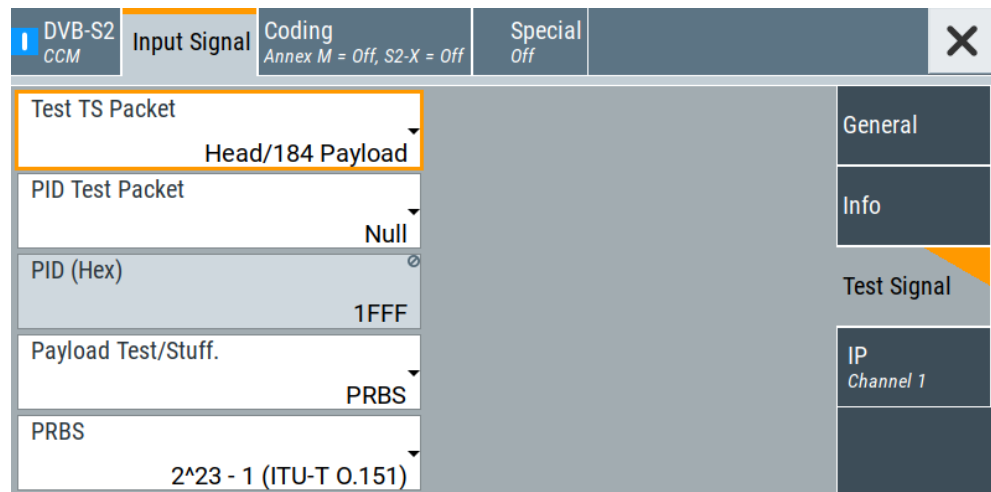

The tab provides settings necessary to configure the input test signal.

Settings:

Test TS Packet	21
PID Test Packet	21
PID (Hex)	21
Payload Test/Stuff.	21
PRBS.....	21

Test TS Packet

Specifies the structure of the test transport stream packet that is fed to the modulator.

"Head/184 Payload"

A sync byte (0x47) followed by three header bytes and 184 payload bytes.

"Sync/187 Payload"

A sync byte (0x47) followed by 187 payload bytes.

Remote command:

[:SOURCE<hw>] :BB:DVBS2:TSPacket on page 64

PID Test Packet

If a header is present in the test packet ("Test TS Packet > Head/184 Payload"), you can specify a fixed or variable packet identifier (PID).

"Null" The header of the test transport stream packets has a fixed setting of null packet header 1FFF (hex).

"Variable" Uses the header value defined with [PID \(Hex\)](#).

Remote command:

[:SOURCE<hw>] :BB:DVBS2:PIDTestpack on page 65

PID (Hex)

Sets the [PID](#).

If "PID Test Packet > Null", "PID (Hex) = 1FFF" is fixed.

If "PID Test Packet > Variable", you can edit the value.

Remote command:

[:SOURCE<hw>] :BB:DVBS2:PID on page 65

Payload Test/Stuff.

Defines the payload area content of the [TS](#) packet.

You can select [PRBS](#) or exclusively data in hexadecimal format as payload.

For "Source > Test Signal", the packet is a test packet.

For "Stuffing > On", the packet is a null packet. Null packets are inserted into the external transport stream to adapt the stream data rate. See also "[Measured Data Rate](#)" on page 20.

Remote command:

[:SOURCE<hw>] :BB:DVBS2:PAYLoad on page 65

PRBS

Sets the length of the PRBS sequence.

You can select a PRBS 15 or a PRBS 23 sequence as specified by ITU-T O.151.

Remote command:

[:SOURce<hw>] :BB:DVBS2:PRBS [:SEquence] on page 65

3.2.4 IP Channel x Settings

Access:

1. Select "Input Signal > General".
2. Select "Source > External"
3. Select "Input > IP"
4. Select "Input Signal > IP Channel x"

Input IP <input type="checkbox"/>	Alias	Alias 1	General
Type Unicast	Multicast Address	226.0.0.0	Info
Port 6 002	IGMPv3 Source Address	0.0.0.0	Test Signal
Ping Source Address	Local IP Data Network ...		IP Channel 1
Ping Result			

The tab provides settings necessary to configure IP channel x.

You can configure settings for 4 IP channels $x = 1$ to 4 individually, see also "Input Signal > General > IP TS Channel".



IP channel settings affect input IP data of the local IP data network. The settings are independent from the used broadcast standard configuration.

Saving/recalling a certain IP channel or local IP data network configuration is not possible via the broadcast standard-specific functionality.

Use the global save/recall functionality instead, see section "Saving and Recalling Instrument Settings" in the R&S SMCV100B user manual.

The table below shows the availability of the tab in the broadcast standard configuration.

Table 3-1: IP channel configuration support in broadcast standards

Baseband standard	"IP Channel x"	Baseband standard	"IP Channel x"
"ATSC/ATSC-M/H"	Yes	"T-DMB/DAB"	Yes
"ATSC 3.0"	No	"DVB-S"	Yes
"DTMB"	Yes	"DVB-S2"	Yes
"DVB-T"	Yes	"DRM"	No
"DVB-T2"	Yes	"Audio AM"	No
"ISDB-T"	Yes	"Audio FM"	No

See also:

- [Chapter 4.1.1, "How to Apply an External IP Input Signal"](#), on page 51
- [Chapter 3.7, "Local IP Data Network Settings"](#), on page 48

Requirements

At your IP source, set the "transport stream packets per internet protocol packet" (TP per IP) parameter as follows:

- If TP packet length = 188 bytes: Set TP per IP to 7 or 6.
- If TP packet length = 204/208 bytes: Set TP per IP to 6.

We recommend that youFurthermore, we recommend that you use a separate LAN infrastructure to stream the transport streams via IP to the IP connector of the baseband board. We recommend that you avoid TS packet losses during IP transmission.

Settings:

Input IP	23
Alias	23
Type	24
Multicast Address	24
Port	24
IGMPv3 Source Address	24
Ping Source Address	24
Ping Result	24
Local IP Data Network	25

Input IP

Activates/deactivates the IP input.

Remote command:

`[:SOURce<hw>] :BB: INPut : IP<ch> [: STATE]` on page 67

Alias

Sets a unique name for the IP connection.

The definition of a name is optional but facilitates identification in the measurement views. The name input fits maximum 16 characters in ASCII format.

Remote command:

[:SOURce<hw>] :BB:INPut:IP<ch>:ALIAS on page 67

Type

Sets the input signal type.

- "Unicast" Analyzes all unicast IP packets that arrive at the specified "Port".
- "Multicast" When an IP address is in the multicast address range, an attempt is made to join a multicast group using IGMP. Set "Multicast Address" and "Port".

Remote command:

[:SOURce<hw>] :BB:INPut:IP<ch>:TYPE on page 67

Multicast Address

Editing requires "Type > Multicast".

Sets the destination IP address (IPv4) of the IP connection.

You can set addresses from "224.0.0.0" to "239.255.255.255".

Remote command:

[:SOURce<hw>] :BB:INPut:IP<ch>:MULTicast:ADDRESS on page 68

Port

Sets the destination UDP port.

Due to UDP/RTP autosensing, we recommend that you set a port offset of at least 6 between neighboring IP TS channels.

Remote command:

[:SOURce<hw>] :BB:INPut:IP<ch>:PORT on page 67

IGMPv3 Source Address

Requires "Type > Multicast".

Sets the IGMPv3 source address.

If you need to filter the data sent to the multicast address, specify the source address. A source address different from "0.0.0.0" accepts only data originating from the specified IP address.

Remote command:

[:SOURce<hw>] :BB:INPut:IP<ch>:IGMP [:SOURce] :ADDRESS on page 68

Ping Source Address

Clicking "Ping Source Address" triggers pinging of the IGMPv3 source address.

If you set a different value from "IGMPv3 Source Address = 0.0.0.0" and click the button, the software checks if the address is reachable.

Remote command:

[:SOURce<hw>] :BB:INPut:IP<ch>:IGMP [:SOURce] :PING on page 68

Ping Result

Displays the result after pinging the source address.

If "Ping Result > Ping: Successful", the source address is available in the network.

If "Ping Result > Ping: Transmit Failed. xxx", the source address is not available in the network. "xxx" can be, e.g. "General Failure". Try another "IGMPv3 Source Address".

Remote command:

[:SOURce<hw>] :BB:INPut:IP<ch>:IGMP[:SOURce]:RESult? on page 68

Local IP Data Network

Accesses local IP data network settings, see [Chapter 3.7, "Local IP Data Network Settings"](#), on page 48.

3.3 Coding Settings

Access:

- ▶ Select "Baseband > DVB-S2 > Coding".

The tab provides settings for coding.

CM Mode > VCM coding tasks

After specifying the number of input streams, "[Num. Input Streams](#)" on page 16, the following actions are possible:

- Setting all coding parameters for input stream 1 on the "IS1/TSL1" subtab, see [Chapter 3.3.2, "IS1/TSL1 Settings"](#), on page 29.
- If "Num. Input Streams > 1", setting all coding parameters for input streams 2 to maximum 8 on the "IS 2 - x" subtab, see [Chapter 3.3.3, "IS 2 - x Settings"](#), on page 35.

CM Mode > CCM/ACM coding tasks

You can enable annex M and specify the number of time slices. The following actions are possible:

- Setting all coding parameters for time slice 1 on the "IS1/TSL1" subtab, see [Chapter 3.3.2, "IS1/TSL1 Settings"](#), on page 29.
- If "Num. Time Slices > 1", setting all coding parameters for time slice 2 to maximum 8 on the "TSL 2 - 8" subtab, see [Chapter 3.3.4, "TSL 2 - x Settings"](#), on page 36.

The PL header is different for annex M.

Settings:

- [General Settings](#)..... 26
- [IS1/TSL1 Settings](#)..... 29
- [IS 2 - x Settings](#)..... 35
- [TSL 2 - x Settings](#)..... 36

3.3.1 General Settings

Access:

- ▶ Select "Coding > General".

DVB-S2 CCM	Input Signal	Coding <i>Annex M = On, S2-X = On</i>	Special <i>Off</i>		
		Annex M <input checked="" type="checkbox"/>	S2-X <input checked="" type="checkbox"/>	General	
	Symbol Rate 20.000 000 MS/s		Roll Off 0.20	IS1/TSL1	
	Num. Time Slices 1		Channel Bonding <input type="checkbox"/>		
	Super Frame <input type="checkbox"/>				

The tab provides general settings to configure coding.

Settings:

Annex M.....	26
Symbol Rate	27
Roll Off	28
Num. Time Slices.....	28
S2-X.....	28
Super Frame.....	29
Channel Bonding.....	29

Annex M

Enables the annex M features as specified in [EN 302 307](#). Depending on this setting, a different PL header is used.

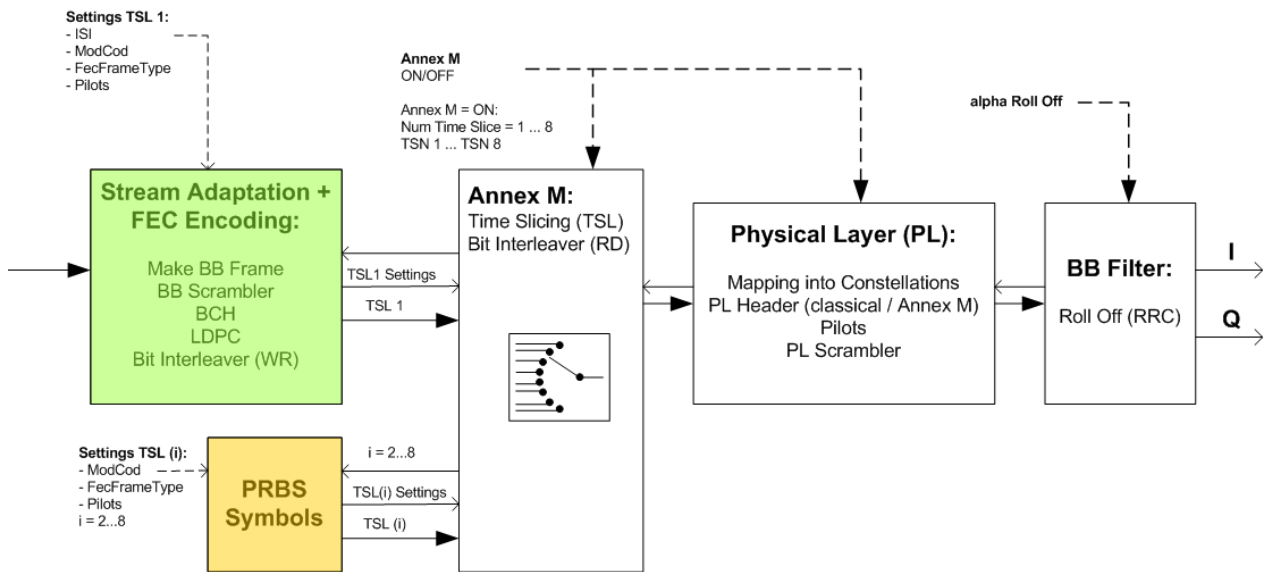

Figure 3-5: Annex M block diagram

Example: Annex M with 3 time slices

Time slice #1: TSN 1, data symbols from FEC encoding

Time slice #2: TSN 2, PRBS data symbols

Time slice #3: TSN 3, PRBS data symbols

Time slice #4: TSN 1, data symbols from FEC encoding (next time slice cycle)

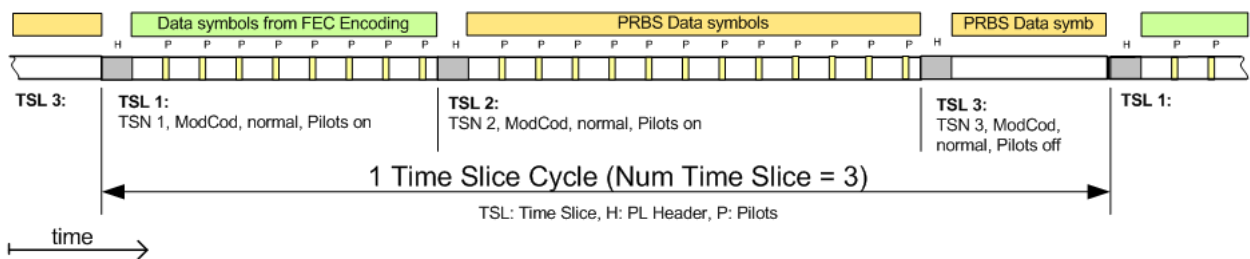

Figure 3-6: Annex M time slicing (timing diagram)

"On" Time-slicing can be activated and more modulation coding settings can be signaled.

"Off" No time-slicing.

Remote command:

`[:SOURCE<hw>] :BB:DVBS2:ANNM` on page 69

Symbol Rate

Sets the symbol rate. In the transmission spectrum, the symbol rate represents the 3 dB bandwidth.

Remote command:

`[:SOURCE<hw>] :BB:DVBS2:SYMBOLS [:RATE]` on page 70

Roll Off

Sets the roll-off alpha factor value.

The output signals are pulse-shaped by an FIR filter, yielding a root raised cosine characteristic. Signaling of RO bits in the MATYPE-1 field of the BB frame header is defined in the specification.

A smaller alpha value produces a steeper drop of the modulation spectrum but the stopband attenuation is lower. A larger alpha value produces a flatter drop of the modulation spectrum. The spectrum is wider but the stopband attenuation is higher.

The 3 dB point of the modulation spectrum is the same for all alpha values.

"0.05"	Signalized as 10 bin alternated with 11 bin.
"0.10"	Signalized as 01 bin alternated with 11 bin.
"0.15"	Signalized as 00 bin alternated with 11 bin.
"0.20"	Default value. Signalized as 10 bin.
"0.25"	Signalized as 01 bin.
"0.35"	Signalized as 00 bin.

Remote command:

[\[:SOURCE<hw>\]:BB:DVBS2:ROLLoff](#) on page 69

Num. Time Slices

Requires "Annex M > On".

Sets the number of time slices

You can set up to 8 time slices. Time slice 1 uses data symbols from FEC encoding, all other time slices use PRBS symbols.

A decoder decodes only one time slice. Real data transmission is only possible with time slice 1.

Every time slice is transmitted once per time slice cycle. The duration of a time slice depends on the settings of this time slice. The duration of a complete time slice cycle depends on the settings of all time slices.

Remote command:

[\[:SOURCE<hw>\]:BB:DVBS2:NTSL](#) on page 70

S2-X

Enables S2-X features.

For DVB-S2-X, additional modulation coding settings are defined to obtain a finer SNR granularity compared to classical S2 modulation coding:

- Clear sky conditions (e.g. 256 APSK)
- Linear channel models (marked with "-L")
- Very low SNR conditions (VL-SNR)
- ...

Related to a DVB-S2-X modulation coding setting is a corresponding LDPC code rate and a FEC frame type. If the order of the modulation coding is higher than QPSK, a bit interleaver pattern is related to this modulation coding setting.

Note: VL-SNR modulation coding, super frame and channel bonding are released in a later version.

Remote command:

[:SOURce<hw>] :BB:DVBS2:S2X on page 60

Super Frame

Requires "S2-X > On".

Enables or disables the super frame.

Remote command:

[:SOURce<hw>] :BB:DVBS2:S2X:SF on page 60

Channel Bonding

Requires "S2-X > On".

Enables or disables the channel bonding.

Remote command:

[:SOURce<hw>] :BB:DVBS2:S2X:CHB on page 69

3.3.2 IS1/TSL1 Settings

Access:

- ▶ Select "Coding > IS1/TSL1".

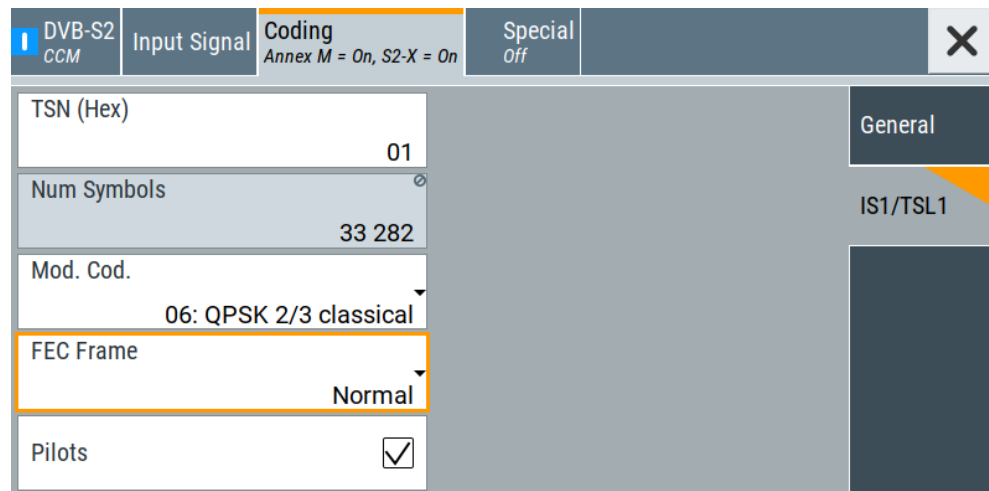

The tab provides coding settings for input stream 1 and time slice 1.

To configure coding settings of the other time slices, see [Chapter 3.3.3, "IS 2 - x Settings"](#), on page 35.

Settings:

TSN (Hex).....	30
ISI (Hex).....	30
Num Symbols.....	30
Mod. Cod.....	30

L Modulation coding values.....	31
FEC Frame.....	34
Pilots.....	35

TSN (Hex)

"TSN (Hex)" requires "CM Mode > CCM/ACM" and "Annex M > On".

Sets the input stream identifier or the time slice number (TSN). This number is used for identification. Each time slice uses a unique TSN.

Configure the TSN for time slice 1. Configure the other time slices in the "TSL 2 - x" tab, see [Chapter 3.3.3, "IS 2 - x Settings"](#), on page 35.

If "CM Mode > VCM", all input streams use the same number and are grouped under time slice 1. You can set the ISI, see ["ISI \(Hex\)"](#) on page 30.

Remote command:

`[:SOURCE<hw>] :BB:DVBS2:TSL<st>:IS<ch>:TSN` on page 72

ISI (Hex)

Requires "CM Mode > VCM".

Sets the input stream identifier (ISI).

All input streams use the same number and are grouped under time slice 1.

If "CM Mode > CCM/ACM", configure the TSN for time slice 1, see ["TSN \(Hex\)"](#) on page 30.

Configure the other time slices in the "TSL 2 - x" tab, see [Chapter 3.3.3, "IS 2 - x Settings"](#), on page 35.

Remote command:

`[:SOURCE<hw>] :BB:DVBS2:TSL<st>:IS<ch>:ISI` on page 70

Num Symbols

Requires "Annex M > On".

Displays the information about the number of symbols.

Note: The setting for time slice 1 is displayed on this side tab, the settings for all time slices > 1 are available on the "TSL 2 - x" side tab. See [Chapter 3.3.3, "IS 2 - x Settings"](#), on page 35.

Remote command:

`[:SOURCE<hw>] :BB:DVBS2:TSL<st>:IS<ch>:NSYM?` on page 71

Mod. Cod.

Defines the modulation coding, a combined setting of constellation and code rate.

Note: The setting for time slice 1 is displayed on this side tab, the settings for all time slices > 1 are available on the "TSL 2 - x" side tab. See [Chapter 3.3.3, "IS 2 - x Settings"](#), on page 35.

For possible values, see ["Modulation coding values"](#) on page 31.

Changes of the modulation coding affect the maximum useful data rate (see ["Max. Useful Data Rate"](#) on page 19): The code rate defines the puncturing rate of the convolutional coder. Since the convolutional coder inserts redundancy into the symbol stream, the code rate influences the max. useful data rate at a given symbol rate.

Remote command:

[:SOURce<hw>] :BB:DVBS2:TSL<st>:IS<ch>:MODCod on page 71

Modulation coding values ← Mod. Cod.

Modulation and coding values depend on the "S2-X" state:

- "S2-X > Off": Classical modulation values only
- "S2-X > On": Classical and S2-X specific coding values

For an overview see [Table 3-2](#), [Table 3-3](#), [Table 3-4](#) and [Table 3-5](#).

Classical modulation coding: If "FEC Frame > Short", not all modulation coding values are available. If the FEC frame is changed to "Short" and the set modulation coding value is not available for this FEC frame value, the modulation coding is automatically changed to the combination with the next lower code rate.

The name of the modulation coding values accords with the canonical name used in the DVB-S2 specifications. It starts with the numeric value that is used as remote command parameter. In the information area, an abbreviation of this name is displayed.

For detailed information about constellation, code rate, bit interleaver pattern and FEC frame type, see the following tables.

Table 3-2: Classical family

Modulation coding value	Bit interleaver pattern	Required FEC frame
1: QPSK 1/4 classical	-	-
2: QPSK 1/3 classical	-	-
3: QPSK 2/5 classical	-	-
4: QPSK 1/2 classical	-	-
5: QPSK 3/5 classical	-	-
6: QPSK 2/3 classical	-	-
7: QPSK 3/4 classical	-	-
8: QPSK 4/5 classical	-	-
9: QPSK 5/6 classical	-	-
10: QPSK 8/9 classical	-	-
11: QPSK 9/10 classical	-	Normal
12: 8PSK 3/5 classical	210	-
13: 8PSK 2/3 classical	012	-
14: 8PSK 3/4 classical	012	-
15: 8PSK 5/6 classical	012	-
16: 8PSK 8/9 classical	012	-
17: 8PSK 9/10 classical	012	Normal
18: 16APSK 2/3 classical	0123	-
19: 16APSK 3/4 classical	0123	-
20: 16APSK 4/5 classical	0123	-

Modulation coding value	Bit interleaver pattern	Required FEC frame
21: 16APSK 5/6 classical	0123	-
22: 16APSK 8/9 classical	0123	-
23: 16APSK 9/10 classical	0123	Normal
24: 32APSK 3/4 classical	01234	-
25: 32APSK 4/5 classical	01234	-
26: 32APSK 5/6 classical	01234	-
27: 32APSK 8/9 classical	01234	-
28: 32APSK 9/10 classical	01234	Normal

Table 3-3: S2-X family for normal FEC frames

Modulation coding value	Implementation description	Bit interleaver pattern	Required FEC frame
29: QPSK 13/45 Sx	QPSK 13/45	-	Normal
30: QPSK 9/20 Sx	QPSK 9/20	-	Normal
31: QPSK 11/20 Sx	QPSK 11/20	-	Normal
32: 8APSK 5/9-L Sx	2+4+2APSK 100/180	012	Normal
33: 8APSK 26/45-L Sx	2+4+2APSK 104/180	012	Normal
34: 8PSK 23/36 Sx	8PSK 23/36	012	Normal
35: 8PSK 25/36 Sx	8PSK 25/36	102	Normal
36: 8PSK 13/18 Sx	8PSK 13/18	102	Normal
37: 16APSK 1/2-L Sx	8+8APSK 90/180	3210	Normal
38: 16APSK 8/15-L Sx	8+8APSK 96/180	2310	Normal
39: 16APSK 5/9-L Sx	8+8APSK 100/180	2301	Normal
40: 16APSK 26/45 Sx	4+12APSK 26/45	3201	Normal
41: 16APSK 3/5 Sx	4+12APSK 3/5	3210	Normal
42: 16APSK 3/5-L Sx	8+8APSK 18/30	0123	Normal
43: 16APSK 28/45 Sx	4+12APSK 28/45	3012	Normal
44: 16APSK 23/36 Sx	4+12APSK 23/36	3021	Normal
45: 16APSK 2/3-L Sx	8+8APSK 20/30	0123	Normal
46: 16APSK 25/36 Sx	4+12APSK 25/36	2310	Normal
47: 16APSK 13/18 Sx	4+12APSK 13/18	3021	Normal
48: 16APSK 7/9 Sx	4+12APSK 140/180	3210	Normal
49: 16APSK 77/90 Sx	4+12APSK 154/180	0321	Normal
50: 32APSK 2/3-L Sx	4+12+16rbAPSK 2/3	21430	Normal

Modulation coding value	Implementation description	Bit interleaver pattern	Required FEC frame
51: 32APSK 32/45 Sx	4+8+4+16APSK 128/180	40312	Normal
52: 32APSK 11/15 Sx	4+8+4+16APSK 132/180	40312	Normal
53: 32APSK 7/9 Sx	4+8+4+16APSK 140/180	40213	Normal
54: 64APSK 32/45-L Sx	16+16+16+16APSK 128/180	305214	Normal
55: 64APSK 11/15 Sx	4+12+20+28APSK 132/180	520143	Normal
56: 64APSK 7/9 Sx	8+16+20+20APSK 7/9	201543	Normal
57: 64APSK 4/5 Sx	8+16+20+20APSK 4/5	124053	Normal
58: 64APSK 5/6 Sx	8+16+20+20APSK 5/6	421053	Normal
59: 128APSK 3/4 Sx	128APSK 135/180	4250316	Normal
60: 128APSK 7/9 Sx	128APSK 140/180	4130256	Normal
61: 256APSK 29/45-L Sx	256APSK 116/180	40372156	Normal
62: 256APSK 2/3-L Sx	256APSK 20/30	01234567	Normal
63: 256APSK 31/45-L Sx	256APSK 124/180	46320571	Normal
64: 256APSK 32/45 Sx	256APSK 128/180	75642301	Normal
65: 256APSK 11/15-L Sx	256APSK 22/30	01234567	Normal
66: 256APSK 3/4 Sx	256APSK 135/180	50743612	Normal

Table 3-4: S2-X family for short FEC frames

Modulation coding value	Implementation description	Bit interleaver pattern	Required FEC frame
67: QPSK 11/45 Sx	QPSK 11/45	-	Short
68: QPSK 4/15 Sx	QPSK 4/15	-	Short
69: QPSK 14/45 Sx	QPSK 14/45	-	Short
70: QPSK 7/15 Sx	QPSK 7/15	-	Short
71: QPSK 8/15 Sx	QPSK 8/15	-	Short
72: QPSK 32/45 Sx	QPSK 32/45	-	Short
73: 8PSK 7/15 Sx	8PSK 7/15	102	Short
74: 8PSK 8/15 Sx	8PSK 8/15	102	Short
75: 8PSK 26/45 Sx	8PSK 26/45	102	Short
76: 8PSK 32/45 Sx	8PSK 32/45	012	Short
77: 16APSK 7/15 Sx	4+12APSK 7/15	2103	Short
78: 16APSK 8/15 Sx	4+12APSK 8/15	2103	Short
79: 16APSK 26/45 Sx	4+12APSK 26/45	2130	Short
80: 16APSK 3/5 Sx	4+12APSK 3/5	3201	Short

Modulation coding value	Implementation description	Bit interleaver pattern	Required FEC frame
81: 16APSK 32/45 Sx	4+12APSK 32/45	0123	Short
82: 32APSK 2/3 Sx	4+12+16rbAPSK 2/3	41230	Short
83: 32APSK 32/45 Sx	4+12+16rbAPSK 32/45	10423	Short

Table 3-5: S2-X family for VL-SNR

Modulation coding value	Implementation description	Required FEC frame
84: VL1 QPSK 2/9 Sx VL-SNR *	QPSK 2/9	Normal
85: VL1 BPSK 1/5 Sx VL-SNR **	$\pi/2$ BPSK 1/5	Medium
86: VL1 BPSK 11/45 Sx VL-SNR **	$\pi/2$ BPSK 11/45	Medium
87: VL1 BPSK 1/3 Sx VL-SNR **	$\pi/2$ BPSK 1/3	Medium
88: VL1 BPSK-S 1/5 Sx VL-SNR	$\pi/2$ BPSK 1/5 Spreading factor 2	Short
89: VL1 BPSK-S 11/45 Sx VL-SNR	$\pi/2$ BPSK 11/45 Spreading factor 2	Short
90: VL2 BPSK 1/5 Sx VL-SNR	$\pi/2$ BPSK 1/5	Short
91: VL2 BPSK 4/15 Sx VL-SNR	$\pi/2$ BPSK 4/15	Short
92: VL2 BPSK 1/3 Sx VL-SNR	$\pi/2$ BPSK 1/3	Short

For all members of this family, the pilot is enabled (fixed setting).
 * For "84: VL1 QPSK 2/9 Sx VL-SNR", the symbol rate is restricted.
 ** For 85, 86, 87: VL1 $\pi/2$ BPSK 1/5, 11/45, 1/3 (medium FEC frame) Sx VL-SNR", padding is performed.

FEC Frame

Sets the length of the FEC frames.

Note: The setting for time slice 1 is displayed on this side tab, the settings for all time slices > 1 are available on the "TSL 2 - x" side tab. See [Chapter 3.3.3, "IS 2 - x Settings"](#), on page 35.

Note: Classical modulation coding: With "Short", not all modulation coding settings are possible. See ["Mod. Cod."](#) on page 30.

FEC frame "Medium" is not available with classical modulation coding.

"Normal"	64800 bit
"Medium"	Requires "S2-X > On". 32400 bit
"Short"	16200 bit

Remote command:

`[:SOURCE<hw>] :BB:DVBS2:TSL<st>:IS<ch>:FECFrame` on page 70

Pilots

Controls the insertion of pilot symbols during the formation of the physical layer frame. Pilot symbols generate an unmodulated carrier and are helpful for synchronizing receivers under difficult transmission conditions.

For all members of the S2-X family VL-SNR, the value is read-only.

"On" Pilot symbols are inserted into the physical layer frame.

"Off" The physical layer frame contains no pilot symbols.

Remote command:

[:SOURce<hw>] :BB:DVBS2:TSL<st>:IS<ch>:PILots on page 71

3.3.3 IS 2 - x Settings

Access:

1. Select "DVB-S2 > CM Mode > VCM", see "CM Mode" on page 11.
2. Select "Input Signal > Num. Input Streams > 1", see "Num. Input Streams" on page 16.
3. Select "Coding > IS 2 - x".

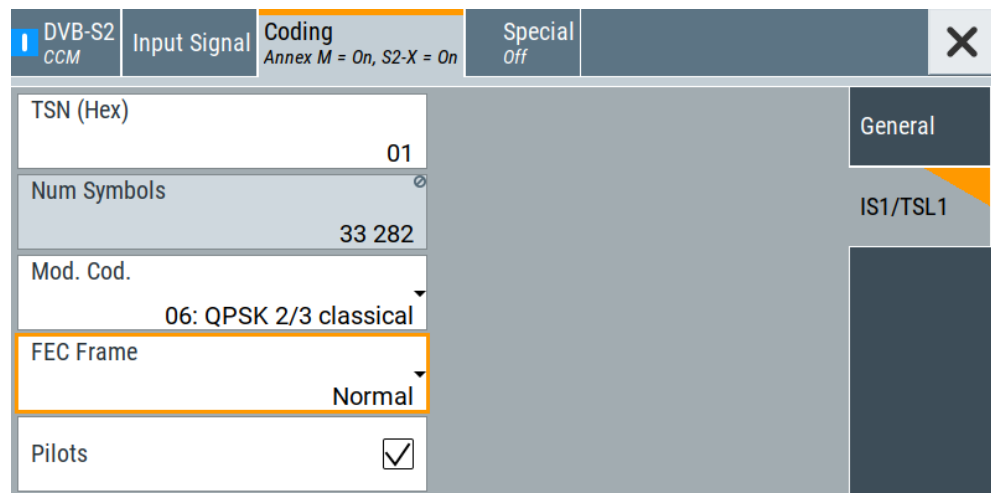

The tab provides coding settings for input stream 2 to maximum 8 in a table, the "Input Stream <num>" table.

The number indicated by x represents the maximum number of input streams set via "Input Signal > Num. Input Streams".

Settings:

[Input Stream <num> table](#).....35

Input Stream <num> table

"Input Stream <num>" table requires "CM Mode > VCM".

The table comprises input stream coding information for input streams 2 to 8, depending on the set number of input streams. See ["Num. Input Streams"](#) on page 16.

You can set and read the following parameters individually:

- [ISI \(Hex\)](#)
- [Mod. Cod.](#)
- [FEC Frame](#)
- [Pilots](#)
- [Num Symbols](#)

3.3.4 TSL 2 - x Settings

Access:

1. Select "DVB-S2 > CM Mode > CCM/ACM", see ["CM Mode"](#) on page 11.
2. Select "Coding > General > Num. Time Slices > 1", see ["Num. Time Slices"](#) on page 28.
3. Select "Coding > TSL 2 - x".

Parameter	Value
TSN (Hex)	01
Num Symbols	33 282
Mod. Cod.	06: QPSK 2/3 classical
FEC Frame	Normal
Pilots	<input checked="" type="checkbox"/>

The tab provides coding settings for time slice 2 to maximum 8 in a table, the "Time Slice <num>" table. The number indicated by x represents the maximum time slice number set via "Num. Time Slices".

Settings:

[Time Slice <num> table](#).....36

Time Slice <num> table

"Time Slice <num>" table requires "CM Mode > CCM/ACM" and "Annex M > On".

The table comprises time slice coding information for time slices 2 to 8, depending on the set number of time slices. See ["Num. Time Slices"](#) on page 28.

You can set and read the following parameters individually:

- [ISI \(Hex\)](#)

- [Mod. Cod.](#)
- [FEC Frame](#)
- [Pilots](#)
- [Num Symbols](#)

3.4 Special Settings

Access:

- ▶ Select "Baseband > DVB-S2 > Special".

Special Settings	
PL Gold Code Index (n)	0
PL Scrambling Sequence ID	0
PL Scrambler	<input checked="" type="checkbox"/>
PL Dataslices PRBS	<input type="checkbox"/>

The tab provides settings, that differ from the specification of the broadcast standard.

If the special settings are active, it is possible that decoding by a DUT is not successful.



Settings different from the broadcast standard can be useful for research and development. Applying these settings requires "Special Settings > On".

If you set a parameter different from the specification, the warning icon is displayed left to the parameter.

Settings:

Special Settings	37
PL Gold Code Index (n)	38
PL Scrambling Sequence ID	38
PL Scrambler	38
PL Dataslices PRBS	38

Special Settings

Enables or disables all special settings.

Remote command:

`[:SOURCE<hw>] :BB:DVBS2 [:SPECial] :SETTings [:STATe]` on page 73

PL Gold Code Index (n)

Requires "PL Scrambling Sequence ID = 0".

Defines the scrambling code number (n) of the gold code used for physical layer (PL) scrambling. This number in turn defines the scrambling sequence within a PL frame.

If "PL Scrambling Sequence ID ≠ 0", the "PL Gold Code Index (n)" is controlled by the "PL Scrambling Sequence ID" and is set internally, but not displayed.

For broadcast applications, set this parameter to "0".

Remote command:

`[:SOURCE<hw>] :BB:DVBS2 [:SPECial] :GOLDCode` on page 72

PL Scrambling Sequence ID

For normal applications, set this parameter to 0.

If ≠ 0 is set, the corresponding line of a hidden file is evaluated. PL header scrambling is performed, and the "PL Gold Code Index (n)" is set using the dedicated values of this line. The results are not displayed and are not readable. Also set the PL scrambling sequence ID in the DVB-S2 receiver.

The maximum value corresponds to the number of active lines in a hidden file, if it exists. In any case, "0" to "16" is possible.

Remote command:

`[:SOURCE<hw>] :BB:DVBS2 [:SPECial] :SCRamble:SEquence` on page 72

PL Scrambler

For test purposes, you can disable the PL scrambler. In normal operation it is enabled.

"On" Normal operation.

"Off" For test purposes, you can disable the PL scrambler.

Remote command:

`[:SOURCE<hw>] :BB:DVBS2 [:SPECial] :SCRamble:STATe` on page 73

PL Dataslices PRBS

Enable for test purposes. PRBS can be inserted into the data slices. The PRBS transmitted in the data slices is continuous, so that a BER measurement on decoded data slices can be performed.

"On" For test purposes, PRBS can be inserted into the data slices. To select the PRBS, see "PRBS" on page 21. The PRBS transmitted in the data slices is continuous, so that a BER measurement on decoded data slices can be performed.

"On" Normal operation.

Remote command:

`[:SOURCE<hw>] :BB:DVBS2 [:SPECial] :DSLPrbs: [STATe]` on page 72

3.5 Global Connector Settings

The "Input Signal" dialog, the "Trigger/Marker/Clock" dialog and "Trigger In", "Marker" and "Clock" tabs in "Baseband > ARB/Custom Digital Mod" configuration dialogs provide quick access to the related connector settings. Click the "Global Connectors" button to access the settings.

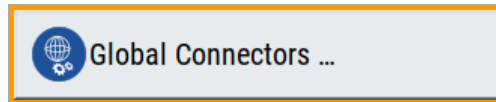

See also chapter "Global Connector Settings" in the user manual.

3.6 TS Player

The "TS Player" application allows you to play stream files for simulation of dedicated transport stream (TS) scenarios. Also, the R&S SMCV100B offers stream libraries containing stream files with a wide range of ready-made signals for testing systems with different transmission parameters. For supported file types, see [Table 3-6](#).

Key features

The key features for playing stream files with "TS Player" application are:

- Support of numerous broadcast transmission standards
- Streaming of high-quality video contents
- Streaming of high-quality audio contents
- Efficient use with dedicated streams

Required options

The equipment layout for processing stream files includes:

- Base unit, including arbitrary waveform generator (64 MSample ARB memory, 60 MHz RF bandwidth)
- Broadcast standard option for the "TS Player" application (R&S SMCVB-Kxxx)
- Enable Broadcast Standards option (R&S SMCVB-K519)
- Optional stream library option (R&S SMCVB-KSxx)

For more information, see data sheet.

To access and download a stream library file

The steps to access a stream library and to download stream library files is analogous as for waveform libraries. See chapter "How to Work with Waveform Libraries" in the R&S SMCV100B user manual.

For information on the content of a stream library, see the user manual of the stream library at:

www.rohde-schwarz.com/manual/smcv100b/ksxx-kvxx-stream-and-waveform-libraries-user-manuals-manuals-gb1_78701-972224.html

To access the "TS Player" application

1. Select "Baseband > DVB-S2 > Input Signal".
2. Select "Source > TS Player".
3. Select "TS Player" button.
Opens the TS player dialog, where you can load files.

Support in broadcast standard configuration

Various broadcast baseband standards of the R&S SMCV100B support the "TS Player" application. For an overview, see the table below.

Baseband standard	"Source > TS Player"	Baseband standard	"Source > TS Player"
"ATSC/ATSC-M/H"	Yes	"T-DMB/DAB"	Yes
"ATSC 3.0"	Yes	"DVB-S"	Yes
"DTMB"	Yes	"DVB-S2"	Yes
"DVB-T"	Yes	"DRM"	No
"DVB-T2"	Yes	"Audio AM"	No
"ISDB-T"	Yes	"Audio FM"	No

The remote commands required to define these settings are described in [Chapter 5.5, "TSGen Subsystem"](#), on page 73.

Settings:

- [TS Player Settings](#)..... 40
- [Player Output Settings](#)..... 43
- [Seamless Loop Settings](#)..... 47

3.6.1 TS Player Settings

Access:

1. Follow the steps in ["To access the "TS Player" application"](#) on page 40.

2. Select "TS Player > TS-Player".

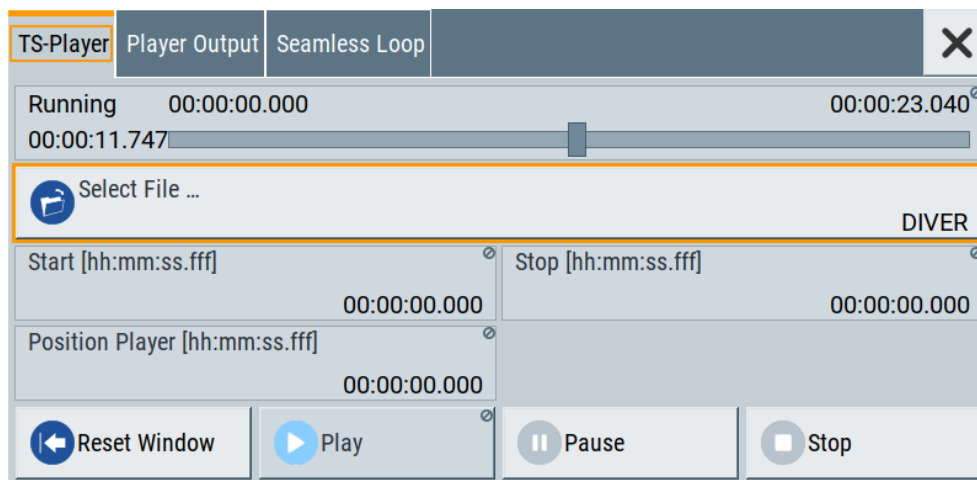

The tab provides settings necessary to configure the general settings of the TS player application.

Settings:

Running/Position Player [hh:mm:ss.fff]..... 41
 Select File..... 41
 Start [hh:mm:ss.fff]..... 42
 Position Player [hh:mm:ss.fff]..... 43
 Stop [hh:mm:ss.fff]..... 43
 Reset Window..... 43
 Play..... 43
 Pause..... 43
 Stop..... 43

Running/Position Player [hh:mm:ss.fff]

Displays the current position in time, while playing the file.

You can set an individual position via [Position Player \[hh:mm:ss.fff\]](#).

Remote command:

:TSGen:CONFigure:SEEK:POSition on page 78

Select File

Provides access to the standard "File Select" function of the instrument. The provided navigation possibilities in the dialog are self-explanatory.

See also, chapter "File and Data Management" in the R&S SMCV100B User Manual.

The dialog allows you to select user-defined, predefined and recent files. [Table 3-6](#) lists file extensions of supported files.

Table 3-6: Supported TS player file types

File extension	Stream libraries	Remark	Option
*.atsc_c	ATSC/ATSC & Mobile DTV	Encrypted	R&S SMCVB-KS13
*.dab	T-DMB/DAB	Unencrypted	-

File extension	Stream libraries	Remark	Option
*.dab_c	T-DMB/DAB	Encrypted	R&S SMCVB-KS10
*.dabp_c	DAB+	Encrypted	R&S SMCVB-KS11
*.eti	T-DMB/DAB	Unencrypted	-
*.xeti	T-DMB/DAB	Unencrypted	-
*.emc_c	EMC	Encrypted	R&S SMCVB-KS15
*.isdbt_c	ISDB-T	Encrypted	R&S SMCVB-KS12
*.pcap	-	Captured IPv4 stream for ATSC 3.0 player	-
*.t2mi ¹⁾	-	Unencrypted	-
*.t2mi_c	DVB-T2 MI	Encrypted	R&S SMCVB-KS14
*.t2trp_c	DVB-T2 MI	Encrypted	R&S SMCVB-KS14
*.trp	-	Unencrypted	-
*.trp_c	-	Encrypted Included in various stream libraries	R&S SMCVB-KS12 R&S SMCVB-KS17 R&S SMCVB-KS18 R&S SMCVB-KS19 R&S SMCVB-KS20
*.bin	-	Unencrypted	-
*.ts	-	Unencrypted	-
*.mpg	-	Unencrypted	-
*.t10	-	-	-

¹⁾ For T2MI stream files, the data rate of a T2MI file is determined automatically, if the following applies:

- Data rate is not part of the TRP file header information.
- PCR information is not available.
- T2MI TRP file is not encrypted, that means not of type *.t2mi_c.
- TRP file has the *.t2mi file extension.

Remote command:

[:TSGen:CONFigure:PLAYfile](#) on page 76

[:TSGen:READ:PLAYfile:LENGth?](#) on page 81

[:TSGen:READ:FMEMorY](#) on page 80

Start [hh:mm:ss.fff]

Sets the start position in the loaded player file. Data which chronologically precedes the start position is not replayed by the player.

The entered time stamp must chronologically always precede the entry under [Stop](#).

Remote command:

[:TSGen:CONFigure:SEEK:STARt](#) on page 78

Position Player [hh:mm:ss.fff]

Displays the current play position in the file.

Remote command:

[:TSGen:CONFigure:SEEK:POSition](#) on page 78

Stop [hh:mm:ss.fff]

Sets the end position in the player file. Data which chronologically follows the end position is not replayed by the player.

When the player reaches the "Stop" position, it returns to the "Start" position (continuous play).

The entered time stamp must chronologically always follow the entry under [Play](#).

Remote command:

[:TSGen:CONFigure:SEEK:STOP](#) on page 79

Reset Window

Resets "Start/Stop/Position Player" parameters.

Remote command:

[:TSGen:CONFigure:SEEK:RESet](#) on page 78

Play

Plays the selected file.

For supported file types, see [Table 3-6](#).

Remote command:

[:TSGen:CONFigure:COMMand<ch>](#) on page 75

Pause

Pauses the player.

After pausing, you can resume playing the file by clicking "Play" again.

Remote command:

[:TSGen:CONFigure:COMMand<ch>](#) on page 75

Stop

Stops the player and returns to the start position.

Remote command:

[:TSGen:CONFigure:COMMand<ch>](#) on page 75

3.6.2 Player Output Settings

Access:

- ▶ Select "TS Player > Player Output".

The tab provides settings necessary to configure the output of the TS player.

3.6.2.1 General Settings

The tab provides settings necessary to configure general player output properties.

Data Rate.....	44
Orig. Data Rate.....	44
Packet Length.....	44
Nullpacket Stuffing.....	44
Stop Data.....	45

Data Rate

Sets the output data rate of the player.

Note: If "Nullpacket Stuffing > Off", we recommend that you set the output data rate equal to the original data rate.

If you want to use a different data rate, activate "Nullpacket Stuffing". The function ensures that the data stream is replayed in the same way as it was recorded. The time references in the tables of the TS stream are also correct during replay.

Remote command:

[:TSGen:CONFigure:TSRate](#) on page 80

Orig. Data Rate

Displays the calculated original TS data rate.

Remote command:

[:TSGen:READ:ORIGtsrate](#) on page 80

Packet Length

Requires a *.trp, *.trp_c, *.emc or *.emc_c file loaded into the "TS Player" dialog. *.trp files are previously recorded files.

Displays the packet length of the loaded TS player file.

Remote command:

[:TSGen:CONFigure:TSPacket](#) on page 79

Nullpacket Stuffing

Requires a *.trp, *.trp_c, *.emc or *.emc_c file loaded into the "TS Player" dialog. *.trp files are previously recorded files.

Enables or disables nullpacket stuffing.

The output data rate of the TS player equals the original data rate. The equality ensures that the time references in the tables of the played TS stream are correct during replay.

- "On" Activate stuffing, if you need a higher rate than the original data rate. Null packets are inserted into the data stream. To ensure correct time references in the stream tables, activate program clock reference correction ("PCR, DTS/PTS > On").
- "Off" Deactivate stuffing, if you want to use the same data rate as the original data rate.

Remote command:

[:TSGen:CONFigure:STUFFing](#) on page 79

Stop Data

Requires a *.trp, *.trp_c, *.emc or *.emc_c file loaded into the "TS Player" dialog. *.trp files are previously recorded files.

Ensures that a standardized TS data stream is always output at the TS output at the rear of the R&S SMCV100B.

In pause or stop status, the TS generator generates "test packets", which have data and header parts, that can be configured using the [Test TS Packet](#).

Remote command:

[:TSGen:CONFigure:STOPdata](#) on page 79

3.6.2.2 Stuffing Settings

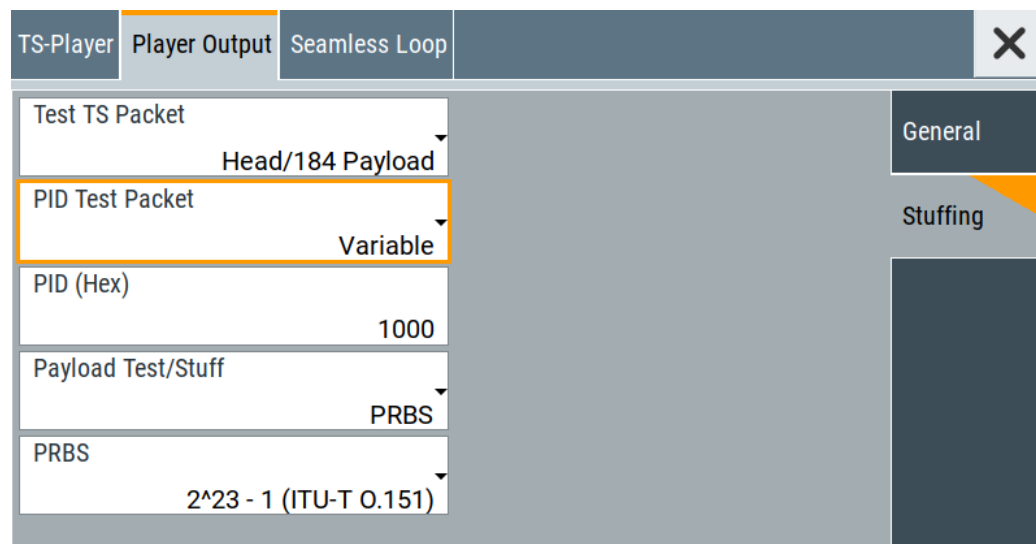

The tab comprises settings necessary to configure stuffing.

Settings

Test TS Packet	46
PID Test Packet	46
PID (Hex)	46
Payload Test/Stuff	46
PRBS	47

Test TS Packet

Specifies the structure of the test transport stream packet that is fed to the modulator.

"Head/184 Payload"

A sync byte (0x47) followed by three header bytes and 184 payload bytes.

"Sync/187 Payload"

A sync byte (0x47) followed by 187 payload bytes.

"Head/200 Payload"

A sync byte (0x47) followed by three header bytes and 200 payload bytes.

"Sync/203 Payload"

A sync byte (0x47) followed) followed by 203 payload bytes.

"Head/204 Payload"

A sync byte (0x47) followed by three header bytes and 204 payload bytes.

"Sync/207 Payload"

A sync byte (0x47) followed) followed by 207 payload bytes.

Remote command:

[:TSGen:CONFigure:TSPacket](#) on page 79

PID Test Packet

If a header is present in the test packet ("Test TS Packet > Head/184 Payload"), you can specify a fixed or variable packet identifier (PID).

"Null" The header of the test transport stream packets has a fixed setting of null packet header 1FFF (hex).

"Variable" Uses the header value defined with [PID \(Hex\)](#).

Remote command:

[:TSGen:CONFigure:PIDTestpack](#) on page 76

PID (Hex)

Sets the [PID](#).

If "PID Test Packet > Null", "PID (Hex) = 1FFF" is fixed.

If "PID Test Packet > Variable", you can edit the value.

Remote command:

[:TSGen:CONFigure:PID](#) on page 76

Payload Test/Stuff

Defines the payload area content of the [TS](#) packet.

"PRBS" PRBS data in accordance with ITU-T O.151
See also chapter "Internal Modulation Data" in the R&S SMCV100B User Manual.

"0x00" Exclusively 00 (hex) data

"0xFF" Exclusively FF (hex) data

Remote command:

:TSGen:CONFigure:PAYLoad on page 75

PRBS

Sets the length of the PRBS sequence.

You can select a PRBS 15 or a PRBS 23 sequence as specified by ITU-T O.151.

Remote command:

:TSGen:CONFigure:PRBS[:SEquence] on page 77

3.6.3 Seamless Loop Settings

Displaying the tab requires a *.trp, *.trp_c, *.emc or *.emc_c file loaded into the "TS Player" dialog. *.trp files are previously recorded files.

Access:

- ▶ Select "TS Player > Seamless Loop".

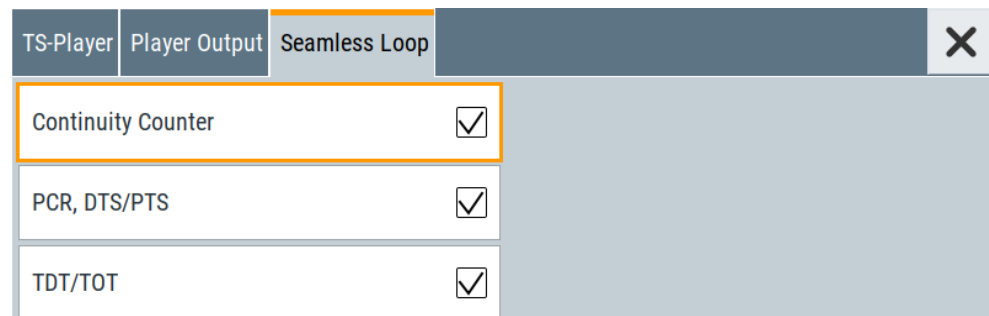

The tab provides settings necessary to configure settings for playing the file in a loop.

Settings:

Continuity Counter.....	47
PCR, DTS/PTS.....	48
TDT/TOT.....	48

Continuity Counter

Activates the correction of the continuity counters in the replayed TS data stream. The correction allows you to decode the stream without interruption when the play file is looping.

Remote command:

:TSGen:CONFigure:SEAMless:CC on page 77

PCR, DTS/PTS

Activates the correction of time stamps in the replayed TS data stream. The correction allows you to decode the stream without interruption when the play file is looping.

If you set "Nullpacket Stuffing = On" and "PCR, DTS/PTS = On", the time stamps in the streams are corrected when nullpackets are inserted into the stream.

Remote command:

:TSGen:CONFigure:SEAMless:PCR on page 77

TDT/TOT

Activates the correction of the time and date table in the replayed TS data stream. The correction allows you to decode the stream without interruption when the play file is looping.

Remote command:

:TSGen:CONFigure:SEAMless:TT on page 78

3.7 Local IP Data Network Settings

Access:

1. Select "Input Signal > General > Source > External".
2. Select "Input Signal > General > Input > IP"
3. Select "Input Signal > IP Channel x > Local IP Data Network".

Board Address		
Address Mode	Protocol	Show Connector ...
Auto (DHCP)	UDP	
IP Address	Subnet Mask	MAC Address
10.214.2.24	255.255.252.0	90:b8:21:71:2e

The tab provides access to local IP data settings necessary to configure the board address.

The remote commands necessary to configure local IP data network settings are described in [Chapter 5.6, "BCIP Subsystem"](#), on page 81.

How to: [Chapter 4.1.1, "How to Apply an External IP Input Signal"](#), on page 51

Settings:

Network Status.....	49
Restart Network.....	49
Hostname.....	49
Address Mode.....	49
IP Address.....	50
Protocol.....	50
Subnet Mask.....	50
Show Connector.....	50
MAC Address.....	50

Network Status

Indicates that the instrument is connected to the network.

If the instrument is disconnected, try "Restart Network".

Remote command:

`:SYSTem:COMMunicate:BCIP<hw>:NETWork:STATus` on page 84

Restart Network

Terminates the network connection of the instrument and sets it up again later. You can use this function to fix network problems.

Note: This function restarts only the connection of the instrument to the network. It does not impact the network itself.

Remote command:

`:SYSTem:COMMunicate:BCIP<hw>:NETWork:REStart` on page 83

Hostname

Displays the hostname.

Displayed is the board name, that is the name of the IP data board of the R&S SMCV100B, e.g. SMCV100B-123456-IP-Data.

Each instrument is delivered with an assigned hostname, a logical name which can be used instead of the IP address. With the default network settings, the IP address is allocated by the DHCP server. This address can change each time the instrument is reconnected. Unlike the IP address, the hostname name does not change.

Note:

This function is password-protected. Unlock the protection level 1 to access it.

We recommend that you do not change the default network settings or the hostname to avoid problems with the network connection.

Remote command:

`:SYSTem:COMMunicate:BCIP<hw>:NETWork:COMMon:HOSTname` on page 82

Address Mode

Selects the mode for assigning the IP address.

"Auto (DHCP)"

Assigns the IP address automatically, provided the network supports DHCP.

"Static"

Enables you to assign the IP address manually.

Remote command:

`:SYSTem:COMMunicate:BCIP<hw>:NETWork:IPADdress:MODE` on page 82

IP Address

Displays the IP address of the instrument in the local IP data network.

By default, the R&S SMCV100B is configured to use dynamic TCP/IP configuration and to obtain the whole address information automatically.

If the network does not support DHCP or the attempt does not succeed, the instrument tries to obtain the IP address via Zeroconf (APIPA) protocol. IP addresses assigned via Zeroconf start with the number blocks 169.254.*.*.

Note: An IP address that is assigned via the Zeroconf protocol although the network requires an IP address assigned via the DHCP server can cause network connection failures.

Remote command:

`:SYSTem:COMMunicate:BCIP<hw>:NETWork:IPADdress` on page 82

Protocol

Sets the protocol type of the input IP data.

The current firmware supports **UDP** and **UDP/RTP**.

Remote command:

`:SYSTem:COMMunicate:BCIP<hw>:NETWork:PROTOcol` on page 83

Subnet Mask

Displays the bit group of the subnet in the host identifier.

To assign the subnet mask manually, select "Address Mode > Static".

Remote command:

`:SYSTem:COMMunicate:BCIP<hw>:NETWork:IPADdress:SUBNet:MASK`
on page 83

Show Connector

Accesses a dialog that displays the physical location of the selected connector on the front/rear panel of the instrument.

MAC Address

Displays the MAC address, a unique identifier of the network adapter in the R&S SMCV100B.

Remote command:

`:SYSTem:COMMunicate:BCIP<hw>:NETWork:MACAddress` on page 83

4 Performing DVB-S2x Signal Generation Tasks

This chapter tells you how to configure the R&S SMCV100B to generate signals for simple receiver tests.

- [Configuring the Input Signal](#).....51
- [Monitoring the Input Signal](#)..... 56

4.1 Configuring the Input Signal

This chapter provides an overview of the different input signals, that the R&S SMCV100B uses as modulation data.

- [How to Apply an External IP Input Signal](#)..... 51
- [How to Apply an External TS Input Signal](#)..... 54
- [How to Generate an Internal TS Signal](#)..... 55

4.1.1 How to Apply an External IP Input Signal

To connect the R&S SMCV100B to local IP data network

1. Connect the IP source to the "IP Data" connector of the R&S SMCV100B.
See chapter "Connecting to IP Data Interface" in the R&S SMCV100B Getting Started user manual.
2. Select "Input Signal > General > Source > External".
3. Select "Input Signal > General > Input > IP".
4. In the "IP Channel x" side tab, click "Local IP Data Network".
By default, the R&S SMCV100B assigns the IP address automatically using **DHCP** ("Address Mode > Auto (DHCP)").
5. If "Network Status > Disconnected", try "Restart Network".

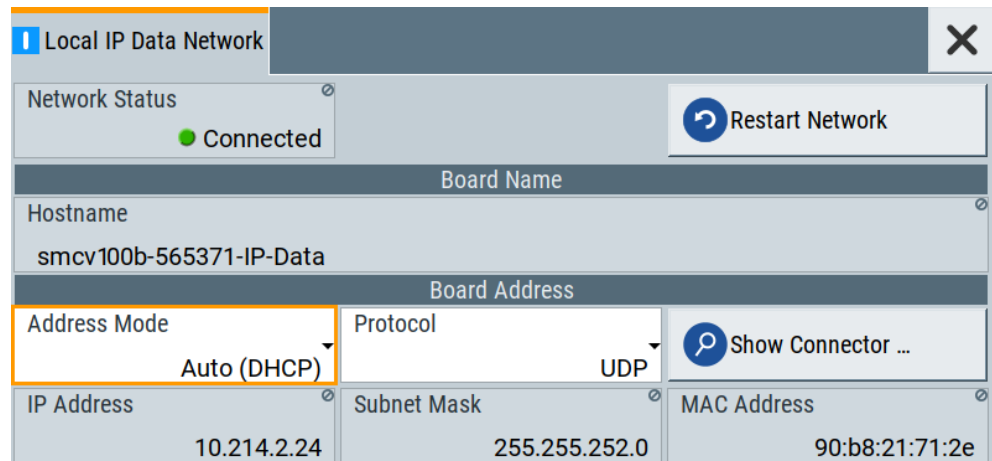

The R&S SMCV100B is connected to the local IP data network.

6. If DHCP does not assign an IP address, assign the IP address manually.
See chapter "How to Assign the IP Address" in the R&S SMCV100B user manual.
7. Specify the protocol type of the input IP data.
The current firmware supports [UDP](#) and [UDP/RTP](#).

To configure an external IP input signal

The R&S SMCV100B is connected to a local IP data network, see ["To connect the R&S SMCV100B to local IP data network"](#) on page 51.

1. Specify general IP input signal properties:
 - a) Select "Input Signal > General > Source > External".
 - b) Select "Input > IP".
 - c) Specify the IP TS Channel, e.g. "IP TS Channel > 1".

The "IP Channel 1" side tab appears, where you can configure the IP connection for channel 1 and channel-independent local IP network settings.

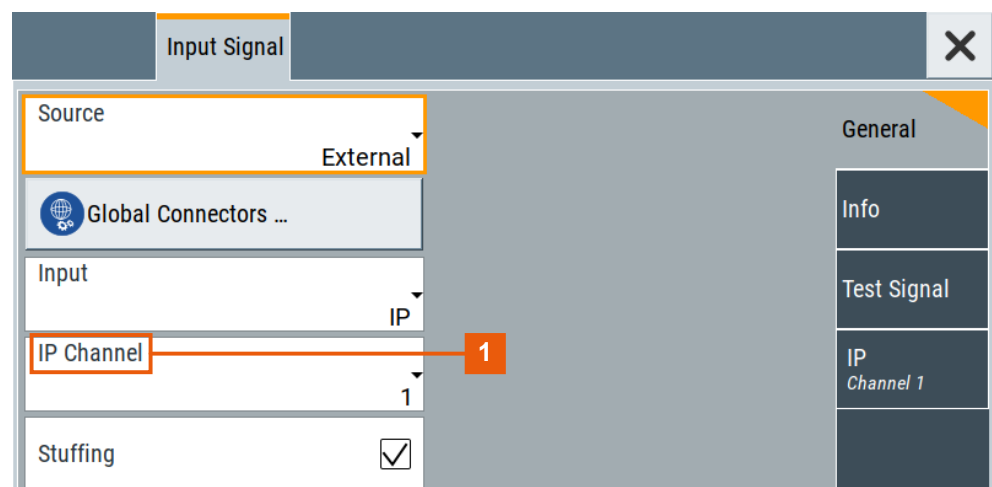

1 = IP channel notation: IP TS Channel

2. Optionally, if supported, activate "Stuffing" to adjust the TS data rate.
3. Specify IP TS channel properties, e.g. for "IP TS Channel > 1":
 - a) Define the input type, e.g. "Type > Multicast".
 - b) Specify the "Multicast Address", that is the destination IPv4 address of the IP connection.
Note: Use the destination address also in the IP data source, e.g. a stream program.
 - c) Specify the port, that is the destination port of the IP connection.
Note: Use the destination port also in the IP data source.
 - d) Specify the **IGMPv3** source address, that is the source IPv4 address of the IP connection.
 A source address different from "0.0.0.0" accepts only data originating from the specified IP address.
 - e) Optionally, to check availability of the "IGMPv3 Source Address", click "Ping Source Address"
 - If "Ping Result > Ping: Successful", the source address is available.
 - If "Ping Result > Ping: Transmit Failed. Destination Host Unreachable", try another address.
 - f) Optionally, specify a name for the IP connection, e.g. "Alias > Service".
 - g) Activate the IP channel, select "Input IP > On".

Input Signal		
Input IP <input checked="" type="checkbox"/>	Alias	General
Type	Service	
Multicast	Multicast Address	Info
	224.3.2.1	
Port	IGMPv3 Source Address	Test Signal
6 002	123.4.5.6	
Ping Source Address	Local IP Data Network ...	IP Channel 1
Ping Result		

The R&S SMCV100B is prepared for receiving IP TS data, that is input at the "IP Data" connector.

Monitor IP data stream properties in the "Info" side tab, see [Chapter 4.2.1, "How to Monitor External IP Input Data"](#), on page 56.

4.1.2 How to Apply an External TS Input Signal

To connect to the external TS input interface

1. Use a double-shielded 75 Ω BNC cable for connection between R&S SMCV100B and the external [MPEG](#) TS data source.
See also Section "Cable selection and electromagnetic interference (EMI)" in the R&S SMCV100B Getting Started user manual.
2. At the R&S SMCV100B, connect the cable to the "User 1" connector.
The connector is on the rear panel of the R&S SMCV100B.
How to: Section "To connect to non-screwable connectors (BNC)" in the R&S SMCV100B Getting Started user manual.

To specify the TS input interface at the R&S SMCV100B

The R&S SMCV100B is [connected](#) to an [MPEG](#) TS data source via the "User 1" connector.

1. Select "Input Signal > General > Source > External".
2. Select "General > Global Connectors".
3. In the "Global Connectors" dialog, configure the "User 1" connector for a TS input signal:
 - a) Select "Direction > Input".
 - b) Select "Signal > TS".

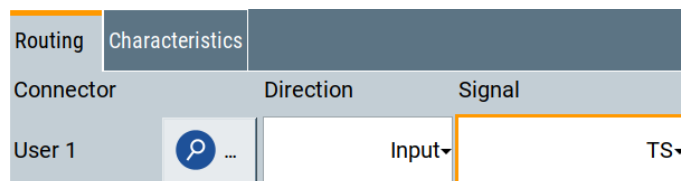

To configure an external TS input signal

The R&S SMCV100B is [prepared](#) for receiving a TS input signal at the "User 1" connector.

1. Specify general TS input signal properties:
 - a) Select "Input Signal > General > Source > External".
 - b) Select "Input > TS IN".
 - c) Specify the format of the input signal:
 - Select "ASI", if you have a source supporting [ASI](#) format.
 - Select "SMPTE 310", if you have a source supporting [SMPTE 310](#) format.
2. Optionally, activate "Stuffing" to adjust the TS data rate.

You can further specify the payload of the stuffing data, see "Test Signal > Payload Test/Stuff."

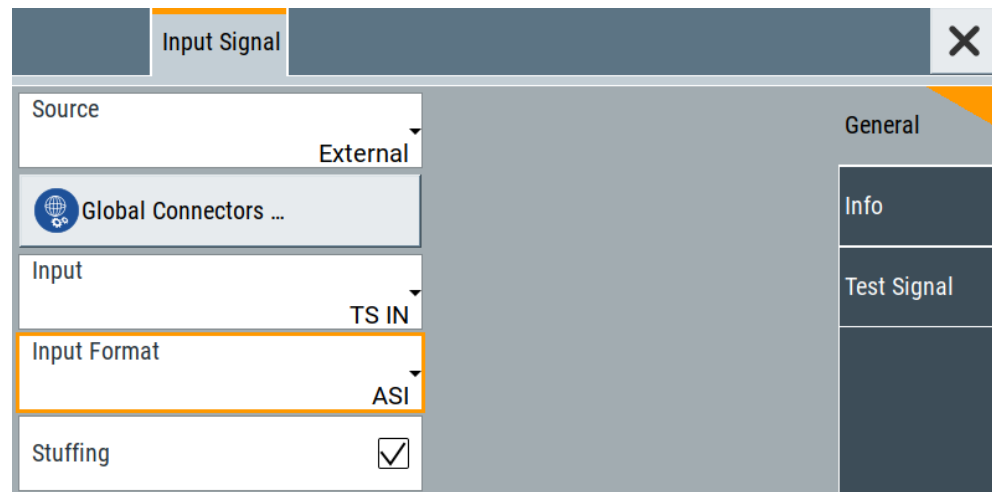

The R&S SMCV100B is prepared for receiving TS data, that is input at the "User 1" connector.

Monitor TS data stream properties in the "Info" side tab, see [Chapter 4.2.2, "How to Monitor an External TS Input Signal"](#), on page 57.

4.1.3 How to Generate an Internal TS Signal

To play a TS file with the "TS Player"

1. Select "Input Signal > Source > TS Player".
The "TS Player" button appears below.
2. Click "TS Player".
The "TS Player" dialog for playing TS data files opens.
3. Click "Play" to play the default file `DIVER.trp`.
Playing the file requires no option.

To play a file of stream library with the "TS Player"

1. Download the
2. Select "Input Signal > Source > TS Player".
The "TS Player" button appears below.
3. Click "TS Player".
The "TS Player" dialog for playing TS data files opens.
4. Click "Play" to play the default file `DIVER.trp`.

Playing the file requires no option.

4.2 Monitoring the Input Signal

This chapter provides an overview of the different input signals, that the R&S SMCV100B uses as modulation data.

- [How to Monitor External IP Input Data](#).....56
- [How to Monitor an External TS Input Signal](#)..... 57
- [How to Monitor an Internal TS Player Signal](#)..... 57

4.2.1 How to Monitor External IP Input Data

The R&S SMCV100B receives external IP input data as described in [Chapter 4.1.1, "How to Apply an External IP Input Signal"](#), on page 51.

- ▶ Select "Input Signal > Info"

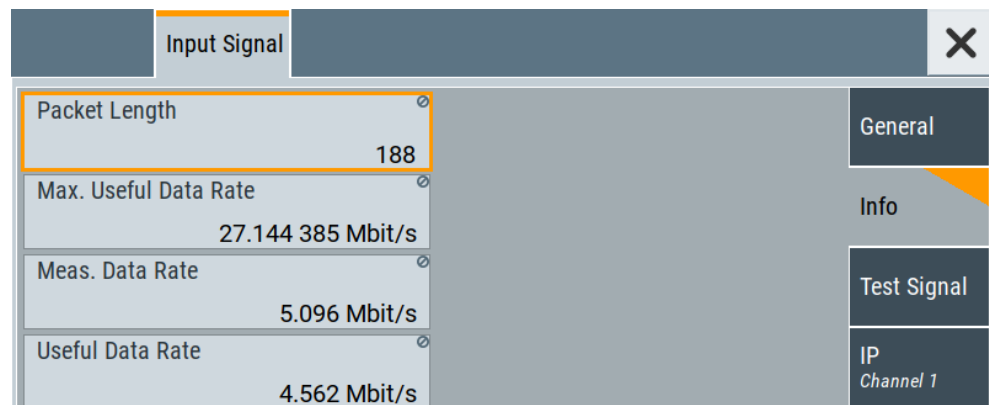

The "Info" side tab displays physical properties of the input IP stream data.

The standard packet length is 188 byte. The maximum useful data rate is specified by the broadcast standard.

The measured data rate is lower and depends on the [TS](#) source settings. The useful data rate is lower than the measured data rate due to null packets present in the transport stream.

If "Stuffing > On", the useful data rate can be lower than the maximum useful data rate.

4.2.2 How to Monitor an External TS Input Signal

The R&S SMCV100B receives external TS input data as described in [Chapter 4.1.2, "How to Apply an External TS Input Signal"](#), on page 54.

- ▶ Select "Input Signal > Info"

Input Signal		General
Packet Length	188	Info
Max. Useful Data Rate	19.392 659 Mbit/s	Test Signal
Measured Data Rate	13.058 Mbit/s	
Useful Data Rate	12.998 Mbit/s	

The "Info" side tab displays physical properties of the input TS stream data.

4.2.3 How to Monitor an Internal TS Player Signal

The R&S SMCV100B receives internal TS input data as described in [Chapter 4.1.3, "How to Generate an Internal TS Signal"](#), on page 55.

- ▶ Select "Input Signal > Info"

Input Signal		General
Max. Useful Data Rate	38.014 706 Mbit/s	Info
Useful Data Rate	21.298 475 Mbit/s	Test Signal

The "Info" side tab displays physical properties of the TS player stream data.

5 Remote-Control Commands

The following commands are required to generate signals with the DVB-S2x option in a remote environment. We assume that the R&S SMCV100B has already been set up for remote operation in a network as described in the R&S SMCV100B documentation. A knowledge about the remote control operation and the SCPI command syntax are assumed.



Conventions used in SCPI command descriptions

For a description of the conventions used in the remote command descriptions, see section "Remote-Control Commands" in the R&S SMCV100B user manual.

Common suffixes

The following common suffixes are used in the remote commands:

Suffix	Value range	Description
SOURce<hw>	1	Available baseband signals
TSL<ch>	1 to 8	Available time slices
IS<ch>	1 to 8	Available input streams

Programming examples

This description provides simple programming examples. The purpose of the examples is to present **all** commands for a given task. In real applications, one would rather reduce the examples to an appropriate subset of commands.

The programming examples have been tested with a software tool which provides an environment for the development and execution of remote tests. To keep the example as simple as possible, only the "clean" SCPI syntax elements are reported. Non-executable command lines (e.g. comments) start with two // characters.

At the beginning of the most remote control program, an instrument preset/reset is recommended to set the instrument to a definite state. The commands *RST and SYSTem:PRESet are equivalent for this purpose. *CLS also resets the status registers and clears the output buffer.

The following commands specific to the DVB-S2x are described here:

- [General Commands](#).....59
- [Input Commands](#).....61
- [Coding Commands](#).....69
- [Special Commands](#).....72
- [TSGen Subsystem](#).....73
- [BCIP Subsystem](#).....81

5.1 General Commands

<code>[:SOURce<hw>]:BB:DVBS2:PRESet</code>	59
<code>[:SOURce<hw>]:BB:DVS2:STATe</code>	59
<code>[:SOURce<hw>]:BB:DVBS2:SETTing:CATalog</code>	59
<code>[:SOURce<hw>]:BB:DVBS2:SETTing:DELete</code>	59
<code>[:SOURce<hw>]:BB:DVBS2:SETTing:LOAD</code>	60
<code>[:SOURce<hw>]:BB:DVBS2:SETTing:STORe</code>	60
<code>[:SOURce<hw>]:BB:DVBS2:S2X</code>	60
<code>[:SOURce<hw>]:BB:DVBS2:S2X:SF</code>	60

`[:SOURce<hw>]:BB:DVBS2:PRESet`

Sets the parameters of the digital standard to their default values (*RST values specified for the commands).

Not affected is the state set with the command `SOURce<hw>:BB:DVBS2:STATe`.

Usage: Event

Manual operation: See "Set To Default" on page 11

`[:SOURce<hw>]:BB:DVS2:STATe <State>`

Activates the standard and deactivates all the other digital standards and digital modulation modes in the same path.

Parameters:

<State> 0 | 1 | OFF | ON

*RST: 0

Manual operation: See "State" on page 11

`[:SOURce<hw>]:BB:DVBS2:SETTing:CATalog`

Queries the files with settings in the default directory. Listed are files with the file extension *.d2vbs.

Return values:

<FileNames> <filename1>,<filename2>,...

Returns a string of filenames separated by commas.

Manual operation: See "Save/Recall" on page 11

`[:SOURce<hw>]:BB:DVBS2:SETTing:DELete <Delete>`

Deletes the selected file from the default or the specified directory. Deleted are files with extension *.d2vbs.

Parameters:

<Filename> "<filename>"
 Filename or complete file path; file extension can be omitted

Usage: Setting only

Manual operation: See ["Save/Recall"](#) on page 11

[:SOURce<hw>]:BB:DVBS2:SETTing:LOAD <Recall>

Loads the selected file from the default or the specified directory. Loaded are files with extension *.d2vbs.

Parameters:

<Filename> "<filename>"
 Filename or complete file path; file extension can be omitted

Manual operation: See ["Save/Recall"](#) on page 11

[:SOURce<hw>]:BB:DVBS2:SETTing:STORe <Save>

Saves the current settings into the selected file; the file extension (*.d2vbs) is assigned automatically.

Parameters:

<Save> "<filename>"
 Filename or complete file path

Manual operation: See ["Save/Recall"](#) on page 11

[:SOURce<hw>]:BB:DVBS2:S2X <S2XState>

Enables S2-X features.

Parameters:

<S2XState> 0 | 1 | OFF | ON
 *RST: 0

Manual operation: See ["S2-X"](#) on page 14

[:SOURce<hw>]:BB:DVBS2:S2X:SF <SuperFrame>

Enables or disables the super frame.

Parameters:

<SuperFrame> 0 | 1 | OFF | ON

Manual operation: See ["Super Frame"](#) on page 29

5.2 Input Commands

- [General Commands](#)..... 61
- [Info Commands](#)..... 62
- [Test Signal Commands](#)..... 64
- [IP Subsystem](#)..... 65

5.2.1 General Commands

[:SOURce<hw>]:BB:DVBS2:SOURce	61
[:SOURce<hw>]:BB:DVBS2[:INPut]:CMMode	61
[:SOURce<hw>]:BB:DVBS2[:INPut]:NIS	61
[:SOURce<hw>]:BB:DVBS2:INPut[:IS<ch>]	62
[:SOURce<hw>]:BB:DVBS2:INPut[:IS<ch>]:FORMat	62
[:SOURce<hw>]:BB:DVBS2:INPut[:IS<ch>]:TSCChannel	62
[:SOURce<hw>]:BB:DVBS2[:IS<ch>]:STUFfing	62

[:SOURce<hw>]:BB:DVBS2:SOURce <Source>

Sets the modulation source for the input signal.

Parameters:

<Source> EXTernal | TSPLayer | TESTsignal
 *RST: EXTernal

Manual operation: See "[Source](#)" on page 16

[:SOURce<hw>]:BB:DVBS2[:INPut]:CMMode <CMMode>

Sets the coding and modulation (CM) mode.

Parameters:

<CMMode> VCM | CCM | ACM
 *RST: CCM

Manual operation: See "[CM Mode](#)" on page 11

[:SOURce<hw>]:BB:DVBS2[:INPut]:NIS <NumInpSig>

Sets the number of input streams. Maximum 8 input streams are possible.

Parameters:

<NumInpSig> float
 Range: 1 to 8
 Increment: 1
 *RST: 1

Manual operation: See "[Num. Input Streams](#)" on page 16

[:SOURce<hw>]:BB:DVBS2:INPut[:IS<ch>] <Input>

Sets the external input interface.

Parameters:

<Input> TS | IP
 *RST: TS

Manual operation: See ["Input "](#) on page 17

[:SOURce<hw>]:BB:DVBS2:INPut[:IS<ch>]:FORMat <InputFormat>

Sets the format of the input signal.

Parameters:

<InputFormat> SMPTE | ASI
 *RST: ASI

Manual operation: See ["Input Format"](#) on page 17

[:SOURce<hw>]:BB:DVBS2:INPut[:IS<ch>]:TSCHeannel <TSChannel>

Selects the IP-based transport stream (TS) channel. You can select 1 out of 4 IP TS channels as input at the "IP Data" interface.

To configure a particular channel, see [Chapter 3.2.4, "IP Channel x Settings"](#), on page 22.

Parameters:

<TSChannel> 1 | 2 | 3 | 4
 *RST: 1

Manual operation: See ["IP TS Channel"](#) on page 17

[:SOURce<hw>]:BB:DVBS2[:IS<ch>]:STUFfing <Stuffing>

Activates stuffing.

Parameters:

<Stuffing> 0 | 1 | OFF | ON
 *RST: 1

Manual operation: See ["Stuffing"](#) on page 18

5.2.2 Info Commands

[:SOURce<hw>]:BB:DVBS2[:IS<ch>]:PACKetlength?	63
[:SOURce<hw>]:BB:DVBS2[:IS<ch>]:USEFul[:RaTE]	63
[:SOURce<hw>]:BB:DVBS2[:IS<ch>]:USEFul[:RATE]:MAX?	63
[:SOURce<hw>]:BB:DVBS2[:INPut[:IS<ch>]:DATarate?	64

[[:SOURce<hw>]:BB:DVBS2[:IS<ch>]:PACKetlength?

Queries the packet length of the external transport stream in bytes.

Return values:

<PacketLength> INValid | P208 | P204 | P188
P188|P204|P208
188/204/208 byte packets specified for serial input and parallel input.

INValid

Packet length does not match the specified length.

*RST: INValid

Usage: Query only

Manual operation: See " [Packet Length](#) " on page 19

[[:SOURce<hw>]:BB:DVBS2[:IS<ch>]:USEFul[:RaTE] <UsefulDataRate>

Displays the data rate of useful data r_{useful} of the external transport stream. The data rate is measured at the input of the installed input interface.

Parameters:

<UsefulDataRate> float
Range: 0 to 999999999
Increment: 0.001
*RST: 0

Manual operation: See " [Useful Data Rate](#) " on page 20

[[:SOURce<hw>]:BB:DVBS2[:IS<ch>]:USEFul[:RATE]:MAX?

Queries the maximum data rate, that is derived from the current modulation parameter settings.

The value is the optimal value at the TS input interface, that is necessary for the modulator.

Return values:

<MaxUseDataRate> float
Range: 0 to 999999999
Increment: 0.000001
*RST: 0

Usage: Query only

Manual operation: See "[Max. Useful Data Rate](#)" on page 19

[:SOURce<hw>]:BB:DVBS2[:INPut][:IS<ch>]:DATarate?

Queries the measured value of the data rate of one of the following:

- External transport stream including null packets input at "User 1" connector
- External transport stream including null packets input at "IP Data/LAN" connector (TSoverIP)

The value equals the sum of useful data rate r_{meas} and the rate of null packets r_0 :

$$r_{\text{meas}} = r_{\text{meas}} + r_0$$

Return values:

<MeasDataRate> float
 Range: 0 to 999999999
 Increment: 0.001
 *RST: 0

Usage: Query only

Manual operation: See " [Measured Data Rate](#) " on page 20

5.2.3 Test Signal Commands

[:SOURce<hw>]:BB:DVBS2:TSPacket	64
[:SOURce<hw>]:BB:DVBS2[:IS<ch>]:TESTsignal	64
[:SOURce<hw>]:BB:DVBS2:PAYLoad	65
[:SOURce<hw>]:BB:DVBS2:PID	65
[:SOURce<hw>]:BB:DVBS2:PIDTestpack	65
[:SOURce<hw>]:BB:DVBS2:PRBS[:SEQUence]	65

[:SOURce<hw>]:BB:DVBS2:TSPacket <TSPacket>

Specifies the structure of the test transport stream packet that is fed to the modulator.

Parameters:

<TSPacket> H184 | S187
 *RST: H184

Manual operation: See " [Test TS Packet](#) " on page 21

[:SOURce<hw>]:BB:DVBS2[:IS<ch>]:TESTsignal <TestSignal>

Defines the test signal data.

Parameters:

<TestSignal> TTSP

Manual operation: See " [Test Signal](#) " on page 18

[[:SOURce<hw>]:BB:DVBS2:PAYLoad <Payload>

Defines the payload area content of the TS packet.

Parameters:

<Payload> 0xFF | 0x00 | PRBS
 *RST: PRBS

Manual operation: See " [Payload Test/Stuff.](#) " on page 21

[[:SOURce<hw>]:BB:DVBS2:PID <PID>

Sets the [PID](#).

Parameters:

<PID> float
 Range: #H0 to #HFFF
 Increment: 1
 *RST: #H0

Manual operation: See " [PID \(Hex\)](#) " on page 21

[[:SOURce<hw>]:BB:DVBS2:PIDTestpack <PIDTestPacket>

If a header is present in the test packet ("Test TS Packet > Head/184 Payload"), you can specify a fixed or variable packet identifier (PID).

Parameters:

<PIDTestPacket> VARIable | NULL
 *RST: NULL

Manual operation: See " [PID Test Packet](#) " on page 21

[[:SOURce<hw>]:BB:DVBS2:PRBS[:SEQUence] <PRBS>

Sets the length of the PRBS sequence.

You can select a PRBS 15 or a PRBS 23 sequence as specified by [ITU-T O.151](#).

Parameters:

<PRBS> P15_1 | P23_1
 *RST: P23_1

Manual operation: See "[PRBS](#)" on page 21

5.2.4 IP Subsystem

The `SOURCE:BB:INPUT:IP` subsystem contains the commands for configuring input IP data from a local IP data network.

To configure local IP data network parameters, see [Chapter 5.6, "BCIP Subsystem"](#), on page 81.

Common suffixes

The following common suffixes are used in the `SOURCE:BB:INPUT:IP` remote commands:

Suffix	Value range	Description
IP<ch>	1 to 4	IP channel number

Example: Configure IP channel 2 properties

```
// Use the data from IP channel 2 as input for modulation data.
:SOURce1:BB:INPut:IP2:STATe ON
// Specify alias as "Alias 2".
:SOURce1:BB:INPut:IP2:ALias "Alias 2"

//*****
// Define Unicast properties.
//*****
:SOURce1:BB:INPut:IP2:TYPe UNI
// Local IP data interface is configured for Unicast reception
:SOURce1:BB:INPut:IP2:PORT 6002

//*****
// Define Multicast properties.
//*****
:SOURce1:BB:INPut:IP2:TYPe MULT
// Local IP data interface is configured for Multicast reception
:SOURce1:BB:INPut:IP2:MULTicast:ADDRes?
// Response: "226.0.0.0"
:SOURce1:BB:INPut:IP2:IGMP:SOURce:ADDRes?
// Response: "0.0.0.0"
:SOURce1:BB:INPut:IP2:IGMP:SOURce:ADDRes "192.168.10.1"
:SOURce1:BB:INPut:IP2:IGMP:SOURce:PING
:SOURce1:BB:INPut:IP2:IGMP:SOURce:RESult?
// Response: "Ping: Successful"
```

Commands

<code>[:SOURCE<hw>]:BB:INPut:IP<ch>[:STATe]</code>	67
<code>[:SOURCE<hw>]:BB:INPut:IP<ch>:ALias</code>	67
<code>[:SOURCE<hw>]:BB:INPut:IP<ch>:PORT</code>	67
<code>[:SOURCE<hw>]:BB:INPut:IP<ch>:TYPe</code>	67
<code>[:SOURCE<hw>]:BB:INPut:IP<ch>:MULTicast:ADDRes</code>	68
<code>[:SOURCE<hw>]:BB:INPut:IP<ch>:IGMP[:SOURce]:ADDRes</code>	68
<code>[:SOURCE<hw>]:BB:INPut:IP<ch>:IGMP[:SOURce]:PING</code>	68
<code>[:SOURCE<hw>]:BB:INPut:IP<ch>:IGMP[:SOURce]:RESult?</code>	68

[:SOURce<hw>]:BB:INPut:IP<ch>[:STATe] <Alias>

Activates/deactivates the "IP Channel x" as IP input.

Specify the current IP TS Channel with the command

SOURce1:BB:DigStd:INPut:TSCHannel. DigStd stands for the IP TS Channel in the corresponding broadcast standard.

Parameters:

<Alias> 0 | 1 | OFF | ON
 *RST: 0

Example: See [Example "Configure IP channel 2 properties"](#) on page 66.

Manual operation: See ["Input IP"](#) on page 23

[:SOURce<hw>]:BB:INPut:IP<ch>:ALIAS <Alias>

Specifies an alias, i.e. name for the IP connection.

Parameters:

<Alias> string

Example: See [Example "Configure IP channel 2 properties"](#) on page 66.

Manual operation: See ["Alias"](#) on page 23

[:SOURce<hw>]:BB:INPut:IP<ch>:PORT <Port>

Sets the port of the input IP data at the "IP Data" connector.

Parameters:

<Port> integer
 Range: 0 to 65535
 *RST: 6002

Example: See [Example "Configure IP channel 2 properties"](#) on page 66.

Manual operation: See ["Port"](#) on page 24

[:SOURce<hw>]:BB:INPut:IP<ch>:TYPE <Type>

Sets the IP input type.

Parameters:

<Type> UNicast | MULTicast

UNicast

Analyzes all unicast IP packets that arrive at the specified port.

See [\[:SOURce<hw>\]:BB:INPut:IP<ch>:PORT](#) on page 67.

MULTicast

When an IP address is in the multicast address range, an attempt is made to join a multicast group using IGMP. Set multicast address and port.

See:

[\[:SOURce<hw>\]:BB:INPut:IP<ch>:MULTicast:ADDRESS](#) on page 68

[\[:SOURce<hw>\]:BB:INPut:IP<ch>:PORT](#) on page 67

*RST: UNicast

Example: See [Example "Configure IP channel 2 properties"](#) on page 66.

Manual operation: See ["Type"](#) on page 24

[:SOURce<hw>]:BB:INPut:IP<ch>:MULTicast:ADDRESS

Sets the destination IP address (IPv4) of the IP connection.

Parameters:

<Address> string
Range: 224.0.0.0 to 239.255.255.255

Example: See [Example "Configure IP channel 2 properties"](#) on page 66.

Manual operation: See ["Multicast Address"](#) on page 24

[:SOURce<hw>]:BB:INPut:IP<ch>:IGMP[:SOURce]:ADDRESS

Specifies the IGMP source address of the network.

Parameters:

<Address> string

Example: See [Example "Configure IP channel 2 properties"](#) on page 66.

Manual operation: See ["IGMPv3 Source Address"](#) on page 24

[:SOURce<hw>]:BB:INPut:IP<ch>:IGMP[:SOURce]:PING

Triggers pinging of the IGMP source address in the local IP data network. Query the result via [\[:SOURce<hw>\]:BB:INPut:IP<ch>:IGMP\[:SOURce\]:RESult?](#) on page 68.

Example: See [Example "Configure IP channel 2 properties"](#) on page 66.

Usage: Event

Manual operation: See ["Ping Source Address"](#) on page 24

[:SOURce<hw>]:BB:INPut:IP<ch>:IGMP[:SOURce]:RESult?

Queries the result of pinging the IGMP source address.

See `[:SOURce<hw>] :BB:INPut:IP<ch>:IGMP [:SOURce] :PING` on page 68.

Return values:

<PingResult> string
Returns ping messages.

Example: See [Example "Configure IP channel 2 properties"](#) on page 66.

Usage: Query only

Manual operation: See ["Ping Result"](#) on page 24

5.3 Coding Commands

- [General Commands](#).....69
- [TSL Commands](#).....70

5.3.1 General Commands

<code>[:SOURce<hw>] :BB:DVBS2:ANNM</code>	69
<code>[:SOURce<hw>] :BB:DVBS2:ROLLoff</code>	69
<code>[:SOURce<hw>] :BB:DVBS2:S2X:CHB</code>	69
<code>[:SOURce<hw>] :BB:DVBS2:NTSL</code>	70
<code>[:SOURce<hw>] :BB:DVBS2:SYMBOLs [:RATE]</code>	70

`[:SOURce<hw>] :BB:DVBS2:ANNM <AnnexN>`

Enables the annex M features as specified in [EN 302 307](#). Depending on this setting, a different PL header is used.

Parameters:

<AnnexN> 0 | 1 | OFF | ON
*RST: 0

Manual operation: See ["Annex M"](#) on page 13

`[:SOURce<hw>] :BB:DVBS2:ROLLoff <RollOff>`

Sets the roll-off alpha factor value.

Parameters:

<RollOff> 0.35 | 0.25 | 0.20 | 0.15 | 0.10 | 0.05
*RST: 0_20

Manual operation: See ["Roll Off"](#) on page 28

`[:SOURce<hw>] :BB:DVBS2:S2X:CHB <ChanBonding>`

Enables or disables the chanel bonding.

Parameters:

<ChanBonding> 0 | 1 | OFF | ON

Manual operation: See "Channel Bonding" on page 29

[[:SOURce<hw>]:BB:DVBS2:NTSL <NumTimeSlice>

Parameters:

<NumTimeSlice> float
 Range: 1 to 8
 Increment: 1
 *RST: 1

Manual operation: See "Num. Time Slices" on page 28

[[:SOURce<hw>]:BB:DVBS2:SYMBOLs[:RATE] <SymbolRate>

Sets the symbol rate. In the transmission spectrum, the symbol rate represents the 3 dB bandwidth.

Parameters:

<SymbolRate> float
 Range: 0,100000 to 90,000000
 Increment: 1
 *RST: 20,000000

Manual operation: See "Symbol Rate" on page 27

5.3.2 TSL Commands

[[:SOURce<hw>]:BB:DVBS2:TSL<st>:IS<ch>:FECFrame.....	70
[[:SOURce<hw>]:BB:DVBS2:TSL<st>:IS<ch>:ISI.....	70
[[:SOURce<hw>]:BB:DVBS2:TSL<st>:IS<ch>:MODCod.....	71
[[:SOURce<hw>]:BB:DVBS2:TSL<st>:IS<ch>:NSYM?.....	71
[[:SOURce<hw>]:BB:DVBS2:TSL<st>:IS<ch>:PILots.....	71
[[:SOURce<hw>]:BB:DVBS2:TSL<st>:IS<ch>:TSN.....	72

[[:SOURce<hw>]:BB:DVBS2:TSL<st>:IS<ch>:FECFrame <FECFrame>

Sets the length of the FEC frames.

Parameters:

<FECFrame> SHORT | NORMAl | MEDium
 *RST: NORMAl

Manual operation: See "FEC Frame" on page 34

[[:SOURce<hw>]:BB:DVBS2:TSL<st>:IS<ch>:ISI <ISI>

Sets the input stream identifier (ISI).

Parameters:

<ISI> integer
 Range: 1 to 8

Manual operation: See "[ISI \(Hex\)](#)" on page 30

[[:SOURce<hw>]:BB:DVBS2:TSL<st>:IS<ch>:MODCod <ModCod>

Defines the modulation coding, a combined setting of constellation and code rate.

Parameters:

<ModCod> 0 | 1 | 10 | 100 | 101 | 102 | 103 | 104 | 105 | 106 | 11 | 12 | 13 |
 14 | 15 | 16 | 17 | 18 | 19 | 2 | 20 | 21 | 22 | 23 | 24 | 25 | 26 | 27 |
 28 | 29 | 3 | 30 | 31 | 32 | 33 | 34 | 35 | 36 | 37 | 38 | 39 | 4 | 40 |
 41 | 42 | 43 | 44 | 45 | 46 | 47 | 48 | 49 | 5 | 50 | 51 | 52 | 53 | 54 |
 55 | 56 | 57 | 58 | 59 | 6 | 60 | 61 | 62 | 63 | 64 | 65 | 66 | 67 | 68 |
 69 | 7 | 70 | 71 | 72 | 73 | 74 | 75 | 76 | 77 | 78 | 79 | 8 | 80 | 81 |
 82 | 83 | 84 | 85 | 86 | 87 | 88 | 89 | 9 | 90 | 91 | 92 | 93 | 94 | 95 |
 96 | 97 | 98 | 99
 *RST: MC6

Manual operation: See "[Mod. Cod.](#)" on page 30

[[:SOURce<hw>]:BB:DVBS2:TSL<st>:IS<ch>:NSYM?

Displays the information about the number of symbols.

Return values:

<NumSym> integer
 Range: 0 to 99999
 *RST: 33372

Usage: Query only

Manual operation: See "[Num Symbols](#)" on page 30

[[:SOURce<hw>]:BB:DVBS2:TSL<st>:IS<ch>:PILots <Pilots>

Controls the insertion of pilot symbols during the formation of the physical layer frame. Pilot symbols generate an unmodulated carrier and are helpful for synchronizing receivers under difficult transmission conditions.

Parameters:

<Pilots> 0 | 1 | OFF | ON
 *RST: 1

Manual operation: See "[Pilots](#)" on page 35

[:SOURce<hw>]:BB:DVBS2:TSL<st>:IS<ch>:TSN <TSN>

Sets the input stream identifier or the time slice number (TSN). This number is used for identification. Each time slice uses a unique TSN.

Parameters:

<TSN> float

Manual operation: See "[TSN \(Hex\)](#)" on page 30

5.4 Special Commands

[:SOURce<hw>]:BB:DVBS2[:SPEcIal]:DSLPrbs[:STATe]	72
[:SOURce<hw>]:BB:DVBS2[:SPEcIal]:GOLDcode	72
[:SOURce<hw>]:BB:DVBS2[:SPEcIal]:SCRamble:SEQUence	72
[:SOURce<hw>]:BB:DVBS2[:SPEcIal]:SCRamble:STATe	73
[:SOURce<hw>]:BB:DVBS2[:SPEcIal]:SETTings[:STATe]	73

[:SOURce<hw>]:BB:DVBS2[:SPEcIal]:DSLPrbs[:STATe] <DataSlicePRBS>

Enable for test purposes. PRBS can be inserted into the data slices. The PRBS transmitted in the data slices is continuous, so that a BER measurement on decoded data slices can be performed.

Parameters:

<DataSlicePRBS> 0 | 1 | OFF | ON
 *RST: 0

Manual operation: See "[PL Dataslices PRBS](#)" on page 38

[:SOURce<hw>]:BB:DVBS2[:SPEcIal]:GOLDcode <ColdCode>

Defines the scrambling code number (n) of the gold code used for physical layer (PL) scrambling. This number in turn defines the scrambling sequence within a PL frame.

Parameters:

<ColdCode> float
 Range: 0 to 262141
 Increment: 1
 *RST: 0

Manual operation: See "[PL Gold Code Index \(n\)](#)" on page 38

[:SOURce<hw>]:BB:DVBS2[:SPEcIal]:SCRamble:SEQUence <ScrSequ>

For normal applications, set this parameter to 0.

If $\neq 0$ is set, the corresponding line of a hidden file is evaluated. PL header scrambling is performed, and the "PL Gold Code Index (n)" is set using the dedicated values of this line. The results are not displayed and are not readable. Also set the PL scrambling sequence ID in the DVB-S2 receiver.

Parameters:

<ScrSequ> float
 Range: 0 to 9999
 Increment: 1
 *RST: 0

Manual operation: See " [PL Scrambling Sequence ID](#) " on page 38

[:SOURce<hw>]:BB:DVBS2[:SPECial]:SCRamble:STATe <Scrambler>

For test purposes, you can disable the PL scrambler. In normal operation it is enabled.

Parameters:

<Scrambler> 0 | 1 | OFF | ON
 *RST: 1

Manual operation: See " [PL Scrambler](#) " on page 38

[:SOURce<hw>]:BB:DVBS2[:SPECial]:SETTings[:STATe] <SpecialSettings>

Enables or disables all special settings.

Parameters:

<SpecialSettings> 0 | 1 | OFF | ON
 *RST: 0

Manual operation: See " [Special Settings](#) " on page 37

5.5 TSGen Subsystem

The TSGen subsystem contains the commands for configuring the TS player.

Example: Play a TS player file

```
//*****
// Select a file, e.g. a user-defined setting.
//*****
:TSGen:CONFigure:PLAYfile "/var/user/my_test_player_test.trp"
// Selects the file "my_test_player_test" with extension *.trp.

//*****
// Within the file, define a section, that you want to play.
// You can set start/stop position for a maximum section length of 10 hours.
//*****
:TSGen:CONFigure:SEEK:START 60000 // milliseconds
```

```

// Section start is after one minute from the original file start.
// The first minute is ignored.
:TSGen:CONFigure:SEEK:STOP 120000 // milliseconds
// Section stop is after one minute from the original file start.
// The total section length is one minute.

//*****
// Navigate to a certain position within the file/section of the file.
//*****
:TSGen:CONFigure:SEEK:POStion 100000 // milliseconds
// The current player position of file/section of the file is at 1 minute 40 seconds.

//*****
// Reset play-related settings
//*****
:TSGen:CONFigure:SEEK:RESet

//*****
// Pause, stop, play the file.
//*****
:TSGen:CONFigure:COMMand PAUS
// Pauses playing the file.
:TSGen:CONFigure:COMMand STOP
// Stops playing the file.
:TSGen:CONFigure:COMMand PLAY
// Activates playing the file.

```

Example: Configure and monitor TS player output

```

//*****
// Configure general and stuffing parameters of the TS player output.
//*****
:TSGen:CONFigure:STUFFing ON
:TSGen:CONFigure:STOPdata TTSP
:TSGen:CONFigure:TSPacket H184
//:TSGen:CONFigure:PIDTestpacket VAR
:TSGen:CONFigure:PIDTestpack VAR
:TSGen:CONFigure:PID 8100
// Corresponds to a PID = 1FA4 in hexadecimal format.
:TSGen:CONFigure:PAYLoad PRBS
:TSGen:CONFigure:PRBS:SEQuence P23_1

//*****
// Monitor TS player output data.
//*****
:TSGen:CONFigure:COMMand STOP
// TSPRate can only be changed if player is in stop mode
:TSGen:CONFigure:TSPRate 350E6 // net data rate = 350 MBit/s
:TSGen:CONFigure:COMMand PLAY

:TSGen:CONFigure:PLENght?
// Response: P188 // packet length = 188 byte

```

```
:TSGen:READ:ORIGtsrate?
// Response: 5018502 bit/s
```

Example: Configure seamless loop parameters

```
:TSGen:CONFigure:SEAMless:CC ON
:TSGen:CONFigure:SEAMless:PCR OFF
:TSGen:CONFigure:SEAMless:TT ON
```

Commands

:TSGen:CONFigure:COMMand<ch>.....	75
:TSGen:CONFigure:PAYLoad.....	75
:TSGen:CONFigure:PID.....	76
:TSGen:CONFigure:PIDTestpack.....	76
:TSGen:CONFigure:PLAYfile.....	76
:TSGen:CONFigure:PLENght.....	77
:TSGen:CONFigure:PRBS[:SEQuence].....	77
:TSGen:CONFigure:SEAMless:CC.....	77
:TSGen:CONFigure:SEAMless:PCR.....	77
:TSGen:CONFigure:SEAMless:TT.....	78
:TSGen:CONFigure:SEEK:POSition.....	78
:TSGen:CONFigure:SEEK:RESet.....	78
:TSGen:CONFigure:SEEK:STARt.....	78
:TSGen:CONFigure:SEEK:STOP.....	79
:TSGen:CONFigure:STOPdata.....	79
:TSGen:CONFigure:STUFfing.....	79
:TSGen:CONFigure:TSPacket.....	79
:TSGen:CONFigure:TSRate.....	80
:TSGen:READ:FMEMemory.....	80
:TSGen:READ:ORIGtsrate.....	80
:TSGen:READ:PLAYfile:LENGth?.....	81

:TSGen:CONFigure:COMMand<ch>

Triggers playing, pausing and stopping of the TS player file selected with `:TSGen:CONFigure:PLAYfile`.

Setting parameters:

```
<PlayerStatus>    STOP | PLAY | PAUSE
                  *RST:    STOP
```

Example: See [Example "Play a TS player file"](#) on page 73.

Usage: Event

Manual operation: See ["Play"](#) on page 43

:TSGen:CONFigure:PAYLoad <PayLoad>

Determines the payload of the test packet. Also influences the payload of the generated stuffing packets while the TS player is running.

Parameters:

<Payload> HFF | H00 | PRBS
 *RST: PRBS

Example: See [Example "Configure and monitor TS player output"](#) on page 74.

Manual operation: See ["Payload Test/Stuff"](#) on page 46

:TSGen:CONFigure:PID <PID>

The available values depend on the settings of `:TSGen:CONFigure:PIDTestpack`.

If `:TSGen:CONFigure:PIDTestpack` is set to NULL,
 then `:TSGen:CONFigure:PID` is 1FFF (hex).

Otherwise the values are variable.

Parameters:

<PID> integer
 Range: 0 to 8191
 *RST: 8191

Example: See [Example "Configure and monitor TS player output"](#) on page 74.

Manual operation: See ["PID \(Hex\)"](#) on page 46

:TSGen:CONFigure:PIDTestpack <PIDTestpack>

Sets the PID, if `:TSGen:CONFigure:TSPacket` is H184 | H200 | H204.

Parameters:

<PIDTestpack> VARIable | NULL
 *RST: NULL

Example: See [Example "Configure and monitor TS player output"](#) on page 74.

Manual operation: See ["PID Test Packet"](#) on page 46

:TSGen:CONFigure:PLAYfile <PlayFile>

Specifies the file path and filename of the TS player file.

Parameters:

<PlayFile> string

Example: See [Example "Play a TS player file"](#) on page 73.

Manual operation: See ["Select File"](#) on page 41

:TSGen:CONFigure:PLENght <PLength>

Queries the packet length of the loaded file.

Parameters:

<PLength> P188 | P204 | P208 | INV
*RST: INV

Example: See [Example "Configure and monitor TS player output"](#) on page 74.

:TSGen:CONFigure:PRBS[:SEQUence] <PRBS>

Sets the length of the PRBS sequence.

Parameters:

<PRBS> P15_1 | P23_1
*RST: P23_1

Example: See [Example "Configure and monitor TS player output"](#) on page 74.

Manual operation: See ["PRBS"](#) on page 47

:TSGen:CONFigure:SEAMless:CC <CC>

Activates the correction of the continuity counters in the replayed TS data stream. The correction allows you to decode the stream without interruption when the play file is looping.

Parameters:

<CC> 0 | 1 | OFF | ON
*RST: 0

Example: See [Example "Configure seamless loop parameters"](#) on page 75.

Manual operation: See ["Continuity Counter"](#) on page 47

:TSGen:CONFigure:SEAMless:PCR <PCR>

Activates the correction of time stamps in the replayed TS data stream. The correction allows you to decode the stream without interruption when the play file is looping.

Parameters:

<PCR> 0 | 1 | OFF | ON
*RST: 0

Example: See [Example "Configure seamless loop parameters"](#) on page 75.

Manual operation: See ["PCR, DTS/PTS"](#) on page 48

:TSGen:CONFigure:SEAMless:TT <TT>

Activates the correction of the time and date table in the replayed TS data stream. The correction allows you to decode the stream without interruption when the play file is looping.

Parameters:

<TT> 0 | 1 | OFF | ON
*RST: 0

Example: See [Example "Configure seamless loop parameters"](#) on page 75.

Manual operation: See ["TDT/TOT"](#) on page 48

:TSGen:CONFigure:SEEK:POSition <Position>

Sets the position, that is the current playing time position.

You can select a value in a 10-hour range.

Parameters:

<Position> float
Range: 0 to 36000000
Increment: 0.1
*RST: 0

Example: See [Example "Play a TS player file"](#) on page 73.

Manual operation: See ["Running/Position Player \[hh:mm:ss:fff\]"](#) on page 41

:TSGen:CONFigure:SEEK:RESet

Resets the following parameters to their default state:

- [:TSGen:CONFigure:SEEK:START](#) on page 78
- [:TSGen:CONFigure:SEEK:STOP](#) on page 79

Example: See [Example "Play a TS player file"](#) on page 73.

Manual operation: See ["Reset Window"](#) on page 43

:TSGen:CONFigure:SEEK:STARt <Start>

Sets an individual start time.

You can select a value in a 10-hour range.

Parameters:

<Start> float
Range: 0 to 36000000
Increment: 0.1
*RST: 0

Example: See [Example "Play a TS player file"](#) on page 73.

Manual operation: See ["Start \[hh:mm:ss.fff\]"](#) on page 42

:TSGen:CONFigure:SEEK:STOP <Stop>

Sets an individual stop time.

You can select a value in a 10-hour range.

Parameters:

<Stop> float
 Range: 0 to 36000000
 Increment: 0.1
 *RST: 23040.2

Example: See [Example "Play a TS player file"](#) on page 73.

Manual operation: See ["Stop \[hh:mm:ss.fff\]"](#) on page 43

:TSGen:CONFigure:STOPdata <StopData>

Ensures that a standardized TS data stream is always output at the TS output at the rear of the R&S SMCV100B.

Parameters:

<StopData> TTSP | NONE
 *RST: NONE

Example: See [Example "Configure and monitor TS player output"](#) on page 74.

Manual operation: See ["Stop Data"](#) on page 45

:TSGen:CONFigure:STUFFing <Stuffing>

Enables or disables nullpacket stuffing.

Parameters:

<Stuffing> 0 | 1 | OFF | ON
 *RST: 0

Example: See [Example "Configure and monitor TS player output"](#) on page 74.

Manual operation: See ["Nullpacket Stuffing"](#) on page 44

:TSGen:CONFigure:TSPacket <TSPaket>

Sets the structure of the generated test packets in pause or stop status.

Parameters:

<TSPaket> H184 | H200 | H204 | S187 | S203 | S207

S187|S203|S207

A sync byte (0x47) followed by 187/203/207 payload bytes.

H184|H200|H204

A sync byte (0x47) followed by three header bytes and 184/200/204 payload bytes.

*RST: H184

Example: See [Example "Configure and monitor TS player output"](#) on page 74.

Manual operation: See ["Packet Length"](#) on page 44

:TSGen:CONFigure:TSRate <TSRate>

Sets the output data rate of the player.

Parameters:

<TSRate> integer
 Range: 1 to 35E7
 *RST: 5018502

Example: See [Example "Configure and monitor TS player output"](#) on page 74.

Manual operation: See ["Data Rate"](#) on page 44

:TSGen:READ:FMEMemory <FMemory>

Queries the file size of the TS player file.

Parameters:

<FMemory> integer
 Range: 0 to 10
 *RST: 0

Example: See [Example "Configure and monitor TS player output"](#) on page 74.

Manual operation: See ["Select File"](#) on page 41

:TSGen:READ:ORIGtsrate <ORIGtsrate>

Displays the calculated original TS data rate.

Parameters:

<ORIGtsrate> integer
 Range: 1 to 350000000
 *RST: 5018502

Example: See [Example "Configure and monitor TS player output"](#) on page 74.

Manual operation: See ["Orig. Data Rate"](#) on page 44

:TSGen:READ:PLAYfile:LENGth?

Queries calculated original loop time.

Return values:

<Length> integer
 Range: 0 to 100
 *RST: 0

Example: See [Example "Configure and monitor TS player output"](#) on page 74.

Usage: Query only

Manual operation: See ["Select File"](#) on page 41

5.6 BCIP Subsystem

The `SYSTEM:COMMunicate:BCIP` subsystem contains the commands for configuring local IP data network parameters.

Common suffixes

The following common suffixes are used in the remote commands:

Suffix	Value range	Description
BCIP<hw>	1	Available local IP LAN interfaces

Example: Retrieving information on local network-related settings

```
//*****
// Monitor IP interface 1 local network status.
//*****
:SYSTEM:COMMunicate:BCIP1:NETWork:STATus?
// Response: "0"
// The instrument is diconnected from the local IP network.
:SYSTEM:COMMunicate:BCIP1:NETWork:REStart
:SYSTEM:COMMunicate:BCIP1:NETWork:STATus?
// Response: "1"

//*****
// Query local IP data network properties.
//*****
:SYSTEM:COMMunicate:BCIP1:NETWork:COMMon:HOSTname?
// Response: "SMCV100B-123456-IP-Data"
:SYSTEM:COMMunicate:BCIP1:NETWork:IPAddress:MODE STAT
:SYSTEM:COMMunicate:BCIP1:NETWork:IPAddress "10.113.0.104"
:SYSTEM:COMMunicate:BCIP1:NETWork:IPAddress:SUBNet:MASK "255.255.252.0"
:SYSTEM:COMMunicate:BCIP1:NETWork:MACAddress?
// Response: "00 90 B8 21 89 F8"
```

```
:SYSTem:COMMunicate:BCIP1:NETWork:PROToCol?
// Response: "UDP"
```

Commands

:SYSTem:COMMunicate:BCIP<hw>:NETWork:COMMon:HOSTname.....	82
:SYSTem:COMMunicate:BCIP<hw>:NETWork:IPADdress.....	82
:SYSTem:COMMunicate:BCIP<hw>:NETWork:IPADdress:MODE.....	82
:SYSTem:COMMunicate:BCIP<hw>:NETWork:IPADdress:SUBNet:MASK.....	83
:SYSTem:COMMunicate:BCIP<hw>:NETWork:MACAdress.....	83
:SYSTem:COMMunicate:BCIP<hw>:NETWork:PROToCol.....	83
:SYSTem:COMMunicate:BCIP<hw>:NETWork:REStart.....	83
:SYSTem:COMMunicate:BCIP<hw>:NETWork:STATus.....	84

:SYSTem:COMMunicate:BCIP<hw>:NETWork:COMMon:HOSTname <Hostname>

Sets an individual hostname for the vector signal generator.

Note: We recommend that you do not change the hostname to avoid problems with the network connection. If you change the hostname, be sure to use a unique name.

Parameters:

<Hostname> string

Example: See [Example "Retrieving information on local network-related settings"](#) on page 81.

Manual operation: See ["Hostname"](#) on page 49

:SYSTem:COMMunicate:BCIP<hw>:NETWork:IPADdress

Sets the IP address.

Parameters:

<IpAddress> string
 Range: 0.0.0.0 to 255.255.255.255
 *RST: 0.0.0.0

Example: See [Example "Retrieving information on local network-related settings"](#) on page 81.

Manual operation: See ["IP Address"](#) on page 50

:SYSTem:COMMunicate:BCIP<hw>:NETWork:IPADdress:MODE <IPMode>

Selects manual or automatic setting of the IP address.

Parameters:

<IPMode> AUTO | STATic
 *RST: AUTO

Example: See [Example "Retrieving information on local network-related settings"](#) on page 81.

Manual operation: See ["Address Mode"](#) on page 49

:SYSTem:COMMunicate:BCIP<hw>:NETWork:IPADdress:SUBNet:MASK

Sets the subnet mask.

Parameters:

<Mask> string
 Range: 0.0.0.0 to 255.255.255.255
 *RST: 0.0.0.0

Example: See [Example "Retrieving information on local network-related settings"](#) on page 81.

Manual operation: See ["Subnet Mask"](#) on page 50

:SYSTem:COMMunicate:BCIP<hw>:NETWork:MACAddress <MACAddress>

Queries the MAC address of the network adapter.

Parameters:

<MACAddress> string
 Range: 00:00:00:00:00:00 to ff:ff:ff:ff:ff:ff

Example: See [Example "Retrieving information on local network-related settings"](#) on page 81.

Manual operation: See ["MAC Address"](#) on page 50

:SYSTem:COMMunicate:BCIP<hw>:NETWork:PROTocol <Protocol>

Specifies the network protocol.

Parameters:

<Protocol> UDP
 *RST: UDP

Example: See [Example "Retrieving information on local network-related settings"](#) on page 81.

Manual operation: See ["Protocol"](#) on page 50

:SYSTem:COMMunicate:BCIP<hw>:NETWork:REStart

Triggers a restart of the network.

Example: See [Example "Retrieving information on local network-related settings"](#) on page 81.

Usage: Event

Manual operation: See ["Restart Network"](#) on page 49

:SYSTem:COMMunicate:BCIP<hw>:NETWork:STATus <NetworkStatus>

Queries the network connection state.

Parameters:

<NetworkStatus> 0 | 1 | OFF | ON

*RST: n.a. (no preset. default: 0)

Example: See [Example "Retrieving information on local network-related settings"](#) on page 81.

Manual operation: See ["Network Status"](#) on page 49

Glossary: Abbreviations

A

ASI: Asynchronous Serial Interface

D

DHCP: Dynamic Host Configuration Protocol

DVB: Digital Video Broadcast

DVB-S: Digital Video Broadcast - Satellite

E

EIRP: Equivalent Isotropically Radiated Power

F

FEC: Forward Error Correction

I

IGMP: Internet Group Management Protocol

IGMPv3: Internet Group Management Protocol version 3

ISI: Input stream identifier

M

MAC: Media Access Control

MIS: Multiple Input Streams

MPEG: Moving Picture Experts Group
<https://mpeg.chiariglione.org/>

O

OFDM: Orthogonal Frequency-Division Multiplexing

P

PCR: Program Clock Reference

PID: Packet Identifier

PL: Physical Layer

PRBS: Pseudo-Random Bit Sequence

PSK: Phase Shift Keying

Q

QAM: Quadrature Amplitude Modulation

QPSK: Quaternary Phase Shift Keying

R

RTP: Real-Time Transport Protocol

S

SMPTE: Society of Motion Picture and Television Engineers
<https://www.smpite.org/>

T

TCP: Transmission Control Protocol

TS: Transport Stream

TSN: Time Slice Number

U

UDP: User Datagram Protocol

Glossary: Specifications

E

EN 302 307: Digital Video Broadcasting (DVB); Second generation framing structure, channel coding and modulation systems for Broadcasting, Interactive Services, News Gathering and other broadband satellite applications (DVB-S2)
https://www.etsi.org/deliver/etsi_en/302300_302399/302307/

I

ITU-T O.151: ITU-T Recommendation O.151
<https://www.itu.int/rec/T-REC-O.151-199210-I/en>

List of commands

:SYSTem:COMMunicate:BCIP<hw>:NETWork:COMMon:HOSTname.....	82
:SYSTem:COMMunicate:BCIP<hw>:NETWork:IPADdress.....	82
:SYSTem:COMMunicate:BCIP<hw>:NETWork:IPADdress:MODE.....	82
:SYSTem:COMMunicate:BCIP<hw>:NETWork:IPADdress:SUNet:MASK.....	83
:SYSTem:COMMunicate:BCIP<hw>:NETWork:MACADdress.....	83
:SYSTem:COMMunicate:BCIP<hw>:NETWork:PROToCol.....	83
:SYSTem:COMMunicate:BCIP<hw>:NETWork:RESArt.....	83
:SYSTem:COMMunicate:BCIP<hw>:NETWork:STATus.....	84
:TSGen:CONFigure:COMManD<ch>.....	75
:TSGen:CONFigure:PAYLoad.....	75
:TSGen:CONFigure:PID.....	76
:TSGen:CONFigure:PIDTestpack.....	76
:TSGen:CONFigure:PLAYfile.....	76
:TSGen:CONFigure:PLENght.....	77
:TSGen:CONFigure:PRBS[:SEQuence].....	77
:TSGen:CONFigure:SEAMless:CC.....	77
:TSGen:CONFigure:SEAMless:PCR.....	77
:TSGen:CONFigure:SEAMless:TT.....	78
:TSGen:CONFigure:SEEK:POStion.....	78
:TSGen:CONFigure:SEEK:RESet.....	78
:TSGen:CONFigure:SEEK:STARt.....	78
:TSGen:CONFigure:SEEK:STOP.....	79
:TSGen:CONFigure:STOPdata.....	79
:TSGen:CONFigure:STUFfing.....	79
:TSGen:CONFigure:TSPacket.....	79
:TSGen:CONFigure:TSRate.....	80
:TSGen:READ:FMEMory.....	80
:TSGen:READ:ORIGtSrate.....	80
:TSGen:READ:PLAYfile:LENGth?.....	81
[:SOURce<hw>]:BB:DVBS2:ANNM.....	69
[:SOURce<hw>]:BB:DVBS2:INPut[:IS<ch>].....	62
[:SOURce<hw>]:BB:DVBS2:INPut[:IS<ch>]:FORMat.....	62
[:SOURce<hw>]:BB:DVBS2:INPut[:IS<ch>]:Tschannel.....	62
[:SOURce<hw>]:BB:DVBS2:NTSL.....	70
[:SOURce<hw>]:BB:DVBS2:PAYLoad.....	65
[:SOURce<hw>]:BB:DVBS2:PID.....	65
[:SOURce<hw>]:BB:DVBS2:PIDTestpack.....	65
[:SOURce<hw>]:BB:DVBS2:PRBS[:SEQuence].....	65
[:SOURce<hw>]:BB:DVBS2:PRESet.....	59
[:SOURce<hw>]:BB:DVBS2:ROLLoff.....	69
[:SOURce<hw>]:BB:DVBS2:S2X.....	60
[:SOURce<hw>]:BB:DVBS2:S2X:CHB.....	69
[:SOURce<hw>]:BB:DVBS2:S2X:SF.....	60
[:SOURce<hw>]:BB:DVBS2:SETTing:CATalog.....	59
[:SOURce<hw>]:BB:DVBS2:SETTing:DELeTe.....	59
[:SOURce<hw>]:BB:DVBS2:SETTing:LOAD.....	60
[:SOURce<hw>]:BB:DVBS2:SETTing:STORe.....	60

[:SOURCE<hw>]:BB:DVBS2:SOURce.....	61
[:SOURCE<hw>]:BB:DVBS2:SYMBOLs[:RATE].....	70
[:SOURCE<hw>]:BB:DVBS2:TSL<st>:IS<ch>:FECFrame.....	70
[:SOURCE<hw>]:BB:DVBS2:TSL<st>:IS<ch>:ISI.....	70
[:SOURCE<hw>]:BB:DVBS2:TSL<st>:IS<ch>:MODCod.....	71
[:SOURCE<hw>]:BB:DVBS2:TSL<st>:IS<ch>:NSYM?.....	71
[:SOURCE<hw>]:BB:DVBS2:TSL<st>:IS<ch>:PILots.....	71
[:SOURCE<hw>]:BB:DVBS2:TSL<st>:IS<ch>:TSN.....	72
[:SOURCE<hw>]:BB:DVBS2:TSPacket.....	64
[:SOURCE<hw>]:BB:DVBS2[:INPut]:CMMode.....	61
[:SOURCE<hw>]:BB:DVBS2[:INPut]:NIS.....	61
[:SOURCE<hw>]:BB:DVBS2[:INPut][:IS<ch>]:DATARate?.....	64
[:SOURCE<hw>]:BB:DVBS2[:IS<ch>]:PACKetlength?.....	63
[:SOURCE<hw>]:BB:DVBS2[:IS<ch>]:STUFFing.....	62
[:SOURCE<hw>]:BB:DVBS2[:IS<ch>]:TESTsignal.....	64
[:SOURCE<hw>]:BB:DVBS2[:IS<ch>]:USEFul[:RaTE].....	63
[:SOURCE<hw>]:BB:DVBS2[:IS<ch>]:USEFul[:RATE]:MAX?.....	63
[:SOURCE<hw>]:BB:DVBS2[:SPECial]:DSLPrbs[:STATe].....	72
[:SOURCE<hw>]:BB:DVBS2[:SPECial]:GOLDcode.....	72
[:SOURCE<hw>]:BB:DVBS2[:SPECial]:SCRamble:SEQUence.....	72
[:SOURCE<hw>]:BB:DVBS2[:SPECial]:SCRamble:STATe.....	73
[:SOURCE<hw>]:BB:DVBS2[:SPECial]:SETTings[:STATe].....	73
[:SOURCE<hw>]:BB:DVBS2:STATe.....	59
[:SOURCE<hw>]:BB:INPut:IP<ch>:ALias.....	67
[:SOURCE<hw>]:BB:INPut:IP<ch>:IGMP[:SOURCE]:ADDRESS.....	68
[:SOURCE<hw>]:BB:INPut:IP<ch>:IGMP[:SOURCE]:PING.....	68
[:SOURCE<hw>]:BB:INPut:IP<ch>:IGMP[:SOURCE]:RESult?.....	68
[:SOURCE<hw>]:BB:INPut:IP<ch>:MULTicast:ADDRESS.....	68
[:SOURCE<hw>]:BB:INPut:IP<ch>:PORT.....	67
[:SOURCE<hw>]:BB:INPut:IP<ch>:TYPE.....	67
[:SOURCE<hw>]:BB:INPut:IP<ch>[:STATe].....	67

Index

A

Annex M	13, 26
Application cards	7
Application notes	7

B

Brochures	6
-----------------	---

C

CM mode	11
Coding	
S2-X	14, 28
Coding settings	25
Channel bonding	29
FEC frame	34
General settings	26
Input stream 2 - x settings	35
Input stream table	35
ISI	30
Modulation coding	30
Num symbols	30
Num time slice	28
Pilots	35
Roll off	28
Super frame	29
Symbol rate	27
Time slice 1 settings	29
Time slice 2 - x settings	36
Time slice table	36
TSN	30
Conventions	
SCPI commands	58

D

Data sheets	6
Default settings	11
Documentation overview	5

G

Getting started	5
-----------------------	---

H

Help	6
------------	---

I

Input signal settings	15
Alias	23
General settings	16
IGMPv3 source address	24
Info	18
Input	17
Input format	17
IP channel x	22
IP input	23
IP network data	48
IP TS channel	17
Local IP data network	25

Maximum useful data rate	19
Measured data rate	20
Multicast address	24
Number of input streams	16
Packet length	19
Payload test/stuff	21
PID	21
PID test packet	21
Ping result	24
Ping source address	24
Port	24
PRBS	21
Source	16
Stuffing	18
Test signal	18
Test signal settings	20
Test TS packet	21
Type	24
Useful data rate	20
Installation	5
Instrument help	6
Instrument security procedures	6
IP input subsystem	
Remote control commands	65

L

Local IP data	
Remote control commands	81
Local IP data network	
Address mode	49
Hostname	49
IP address	50
MAC address	50
Network status	49
Protocol	50
Restart network	49
Show connector	50
Subnet mask	50

O

Open source acknowledgment (OSA)	7
--	---

R

Release notes	7
Remote control	
IP subsystem	65
Local IP data	81
Programming examples	58
TSGen subsystem	73

S

S2-X	14, 28
Safety instructions	6
Save/Recall	11
Security procedures	6
Service manual	6
Set to default	11
Special settings	37
PL dataslices PRBS	38
PL gold code index	38

PL scrambler	38
PL scrambling sequence ID	38
Special settings	37
Standard settings	11
State	11

T

TS player	39
Player output settings	43
Supported file types	41
TS player settings	
Continuity counter	47
Data rate	44
General settings	40
Nullpacket stuffing	44
Orig. data rate	44
Packet length	44
Pause	43
Payload test/stuff	46
PCR, DTS/PTS	48
PID	46
PID test packet	46
Play	43
Position player	43
PRBS	47
Reset window	43
Running	41
Seamless loop settings	47
Select file	41
Start	42
Stop	43
Stop data	45
TDT/TOT	48
Test TS packet	46
TSGen subsystem	
Remote control commands	73

U

User manual	6
-------------------	---

W

White papers	7
--------------------	---