

1260 VXI SWITCHING CARD

1260-20 POWER MODULE

PUBLICATION NO. 980673-004

RACAL INSTRUMENTS

Racal Instruments, Inc.

4 Goodyear St., Irvine, CA 92618-2002
Tel: (800) RACAL-ATE, (800) 722-2528,
(949) 859-8999; FAX: (949) 859-7139

Racal Instruments, Ltd.

480 Bath Road, Slough, Berkshire, SL1 6BE, United Kingdom
Tel: +44 (0) 1628 604455; FAX: +44 (0) 1628 662017

Racal Systems Electronique S.A.

18 Avenue Dutartre, 78150 LeChesnay, France
Tel: +33 (1) 3923 2222; FAX: +33 (1) 3923 2225

Racal Systems Elettronica s.r.l.

Strada 2-Palazzo C4, 20090 Milanofiori Assago, Milan, Italy
Tel: +39 (0)2 5750 1796; FAX +39 (0)2 5750 1828

Racal Elektronik System GmbH.

Technologiepark Bergisch Gladbach, Friedrich-Ebert-Strasse, D-51429 Bergisch Gladbach, Germany
Tel.: +49 2204 8442 00; FAX: +49 2204 8442 19

Racal Australia Pty. Ltd.

3 Powells Road, Brookvale, NSW 2100, Australia
Tel: +612 9936 7000, FAX: +612 9936 7036

Racal Electronics Pte. Ltd.

26 Ayer Rajah Crescent, 04-06/07 Ayer Rajah Industrial Estate, Singapore 0513.
Tel: +65 7792200, FAX: +65 7785400

Racal Instruments, Ltd.

Unit 5, 25F., Mega Trade Center, No 1, Mei Wan Road, Tsuen Wan, Hong Kong, PRC
Tel: +852 2405 5500, FAX: +852 2416 4335

<http://www.racalinstruments.com>



PUBLICATION DATE: August 14, 2000

Copyright 2000 by Racal Instruments, Inc. Printed in the United States of America. All rights reserved.
This book or parts thereof may not be reproduced in any form without written permission of the publisher.

WARRANTY STATEMENT

Products sold by Racal Instruments, Inc. are warranted to be free from defects in workmanship or materials. Racal Instruments, Inc. will, at its option, either repair or replace any hardware products which prove to be defective during the warranty period. You are a valued customer. Our mission is to make any necessary repairs in a reliable and timely manner.

Duration of Warranty

The warranty period for this Racal Instruments, Inc. hardware is three years, except software and firmware products designed for use with Racal Instruments, Inc. Hardware are warranted not to fail to execute their programming instructions due to defect in materials or workmanship for a period of ninety (90) days from the date of delivery to the initial end user.

Return of Product

Authorization is required from Racal Instruments before you send us your product for service or calibration. Call your nearest Racal Instruments support facility. A list is located on the last page of this manual. If you are unsure where to call, contact Racal Instruments, Inc. Customer Support Department in Irvine, California, USA at 1-800-722-3262 or 1-949-859-8999 or via fax at 1-949-859-7309.

Limitation of Warranty

Racal Instruments, Inc. shall be released from all obligations under this warranty in the event repairs or modifications are made by persons other than authorized Racal Instruments service personnel or without the written consent of Racal Instruments.

Racal Instruments, Inc. expressly disclaims any liability to its customers, dealers and representatives and to users of its product, and to any other person or persons, for special or consequential damages of any kind and from any cause whatsoever arising out of or in any way connected with the manufacture, sale, handling, repair, maintenance, replacement or use of said products.

Representations and warranties made by any person including dealers and representatives of Racal Instruments, Inc., which are inconsistent or in conflict with the terms of this warranty (including but not limited to the limitations of the liability of Racal Instruments, Inc. as set forth above), shall not be binding upon Racal Instruments, Inc. unless reduced to writing and approved by an officer of Racal Instruments, Inc.

Except as stated above, Racal Instruments, Inc. makes no warranty, express or implied (either in fact or by operation of law), statutory or otherwise; and except to the extent stated above, Racal Instruments, Inc. shall have no liability under any warranty, express or implied (either in fact or by operation of law), statutory or otherwise.

PROPRIETARY NOTICE

This document and the technical data herein disclosed, are proprietary to Racal Instruments, and shall not, without express written permission of Racal Instruments, be used, in whole or in part to solicit quotations from a competitive source or used for manufacture by anyone other than Racal Instruments. The information herein has been developed at private expense, and may only be used for operation and maintenance reference purposes or for purposes of engineering evaluation and incorporation into technical specifications and other documents which specify procurement of products from Racal Instruments.

FOR YOUR SAFETY

Before undertaking any troubleshooting, maintenance or exploratory procedure, read carefully the **WARNINGS** and **CAUTION** notices.

This equipment contains voltage hazardous to human life and safety, and is capable of inflicting personal injury.

If this instrument is to be powered from the AC line (mains) through an autotransformer, ensure the common connector is connected to the neutral (earth pole) of the power supply.

Before operating the unit, ensure the conductor (green wire) is connected to the ground (earth) conductor of the power outlet. Do not use a two-conductor extension cord or a three-prong/two-prong adapter. This will defeat the protective feature of the third conductor in the power cord.

Maintenance and calibration procedures sometimes call for operation of the unit with power applied and protective covers removed. Read the procedures and heed warnings to avoid "live" circuit points.

Before operating this instrument:

1. Ensure the instrument is configured to operate on the voltage at the power source. See Installation Section.
2. Ensure the proper fuse is in place for the power source to operate.
3. Ensure all other devices connected to or in proximity to this instrument are properly grounded or connected to the protective third-wire earth ground.

If the instrument:

- fails to operate satisfactorily
- shows visible damage
- has been stored under unfavorable conditions
- has sustained stress

Do not operate until performance is checked by qualified personnel.

This page was left intentionally blank.

Table of Contents

Chapter 1	
MODULE SPECIFICATION	1-1
1260-20 Module Specification	1-1
Specifications	1-2
DC Performance	1-2
AC Performance	1-3
Cooling Requirements	1-3
Power Requirements	1-3
Weight	1-3
Minimum Option 01 Firmware	1-3
Chapter 2	
INSTALLATION INSTRUCTIONS	2-1
Unpacking and Inspection	2-1
Reshipment Instructions	2-1
Option 01 Installation	2-2
Module Installation	2-2
Chapter 3	
MODULE SPECIFIC SYNTAX	3-1
1260-20 Module Specific Syntax	3-1
Syntax	3-1
Chapter 4	
DRAWINGS	4-1
Chapter 5	
PARTS LIST	5-1
Chapter 6	
OPTIONAL HARNESS ASSEMBLIES	6-1
Chapter 7	
PRODUCT SUPPORT	7-1
Product Support	7-1

Reshipment Instructions 7-1
Support Offices 7-2

List of Figures

Figure 1-1, 1260-20 Power Module 1-1
Figure 1-2, 1260-20 Relay Diagram..... 1-2
Figure 3-1, 1260-20 Pin Connections 3-3

Chapter 1

MODULE SPECIFICATION

1260-20 Module Specification

The 1260-20 Power Module is a 20-Channel Double-pole, Single-throw power switching module (refer to the diagram in Figure 1-2).

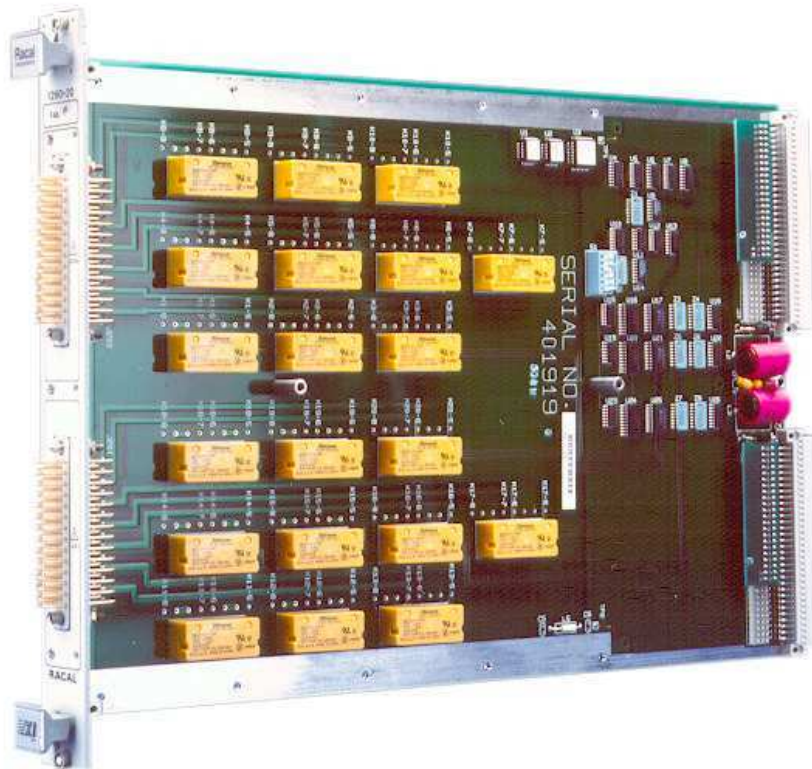

Figure 1-1, 1260-20 Power Module

One channel of model 1260-20 is shown, with provision for addition of series and shunt elements.

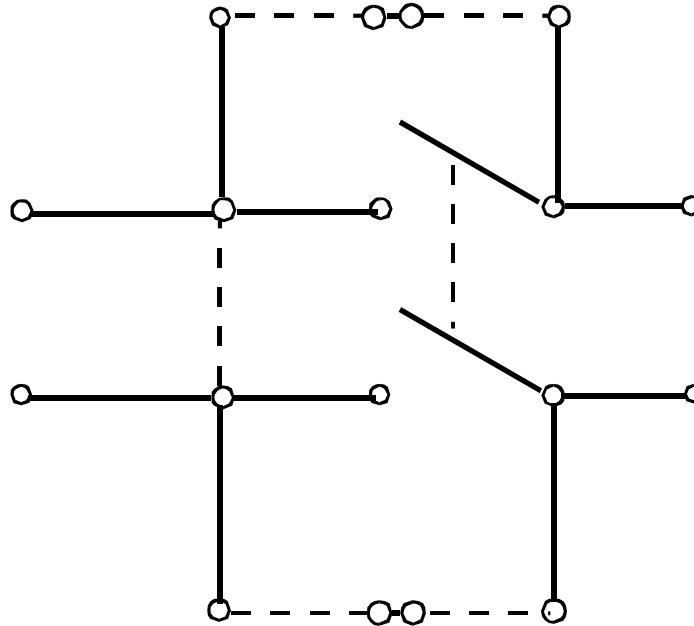

Figure 1-2, 1260-20 Relay Diagram

Specifications

Switch Configuration	20 DPST Relays
User Connector	Positronics GMCT41FOE100JC
Maximum Switchable Voltage	250VDC or 380VAC pk
Maximum Switchable Current (DC or AC RMS) Per Channel	8A
Maximum Switchable Power Per Terminal	150W DC, 2000VA

DC Performance

Path Resistance	150mΩ at 5A DC 50mΩ Typical
Isolation (High-Low)	>10 ⁹ Ω

AC Performance

Capacitance	
Open Channel	< 20pF
Channel-Chassis	< 20pF
Hi-Lo	< 50pF
Bandwidth (-3dB, 50Ω)	30MHz (Typical)
Insertion Loss (50Ω)	< 0.10dB @ 100kHz < 0.10db @ 1MHz < 1.5dB @ 10MHz
Crosstalk (50Ω)	< -60dB @ 100kHz < -40dB @ 1MHz < -20dB @ 10MHz

Cooling Requirements

Airflow	4 liters/sec
Backpressure	0.5mm H ₂ O

Power Requirements

+5V, I _{pm}	0.4A (2.8A with Option 01)
+24V, I _{dm}	10mA per relay

Weight

1.15Kg (2.56lbs) without Option 01 (Smart Card)
1.28Kg (2.84lbs) with Option 01 (Smart Card)

Minimum Option 01 Firmware

Revision	17.1
----------	------

This page was left intentionally blank.

INSTALLATION INSTRUCTIONS

Unpacking and Inspection

1. Before unpacking the switching module, check the exterior of the shipping carton for any signs of damage. All irregularities should be noted on the shipping bill.
2. Remove the instrument from its carton, preserving the factory packaging as much as possible.
3. Inspect the switching module for any defect or damage. Immediately notify the carrier if any damage is apparent.
4. Have a qualified person check the instrument for safety before use.

CAUTION

Proper ESD handling procedures must always be used when packing, unpacking or installing any 1260 Series cards. Failure to do so may cause damage to the unit.

Reshipment Instructions

1. Use the original packing material when returning the switching module to Racal Instruments for calibration or servicing. The original shipping carton and the instrument's plastic foam will provide the necessary support for safe reshipment.
2. If the original packing material is unavailable, wrap the switching module in plastic sheeting and use plastic spray foam to surround and protect the instrument.
3. Reship in either the original or a new shipping carton.

Option 01 Installation

Installation of the Option 01 to the 1260-20 is described in the Installation section of the 1260 Series VXI Switching Cards Manual.

Module Installation

Installation of the 1260-20 Switching Module into a VXI mainframe, including the setting of DIP switches, is described in the Installation section of the 1260 Series VXI Switching Cards Manual. The ID byte DIP switches, SW1-5 and SW1-6, should be set to the OFF state.

Chapter 3

MODULE SPECIFIC SYNTAX

1260-20 Module Specific Syntax

The Module Specific Syntax for the 1260-20 is required in the use of the OPEN and CLOSE commands. It will also appear in data output by the 1260 Master in response to the PDATAOUT and PSETUP commands.

Syntax

The Module Specific Syntax for the 1260-20 Power Switching module is as follows:

<module address>.<switchnumber>

where <module address> is the switch card address.

<switchnumber> is the reference number of the relay to be closed, value 0 - 19.

NOTE

The <module address> used here is NOT the VXibus defined logical address of the 1260 Series Master. It is peculiar to the 1260 Series and describes the switching module in relation to the Master. This address corresponds to the binary value of the switch setting of SW1 on the switching module PCB.

The 1260-20 pin connection made by each <switchnumber> are as follows:

J200		
<switchnumber>	Pin Connection	
0	A to D,	C to K
1	J to L,	E to H
2	M to N,	B to F
3	P to T,	S to Y
4	U to W,	X to e
5	V to a,	R to Z
6	b to j	c to d
7	m to v,	n to h
8	p to r,	f to k
9	x to s,	t to u

J201		
<switchnumber>	Pin Connection	
10	A to D,	C to K
11	J to L,	E to H
12	M to N,	B to F
13	P to T,	S to Y
14	W to X,	U to e
15	V to a,	R to Z
16	b to j	C to d
17	m to v,	N to h
18	p to r,	f to k
19	x to s,	t to u

Refer to Figure 3-1 for the pin configuration of connectors J200 and J201

Revised 8/14/00

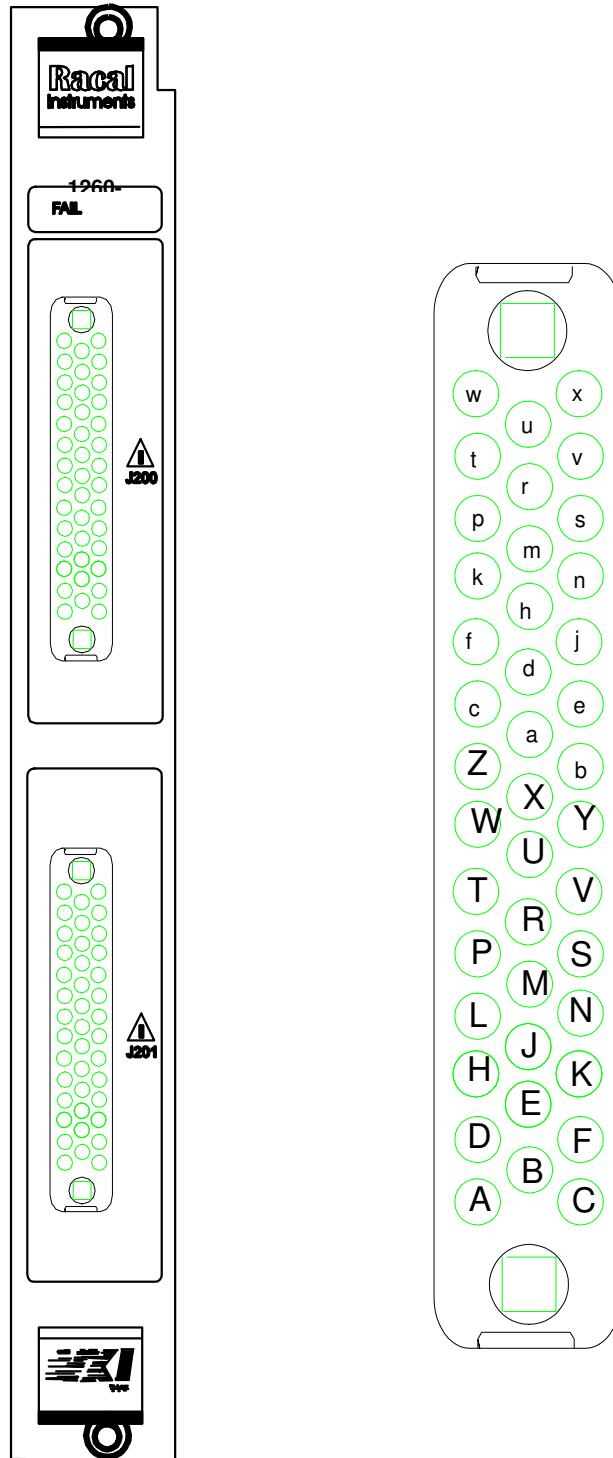

Figure 3-1, 1260-20 Pin Connections

The Racal Instruments part number for the mating connectors for 1260-20 connectors J200 and J201 is 601850, and the contacts required for the mating connectors are Racal Instruments Part Number 601849. 41 contacts are required to fully populate each mating connector.

Chapter 4

DRAWINGS

404773	Final Assy, 1260-20	4-3
401919	PCB Assy, 1260-20.....	4-4
431919	Schematic, 1260-20.....	4-5

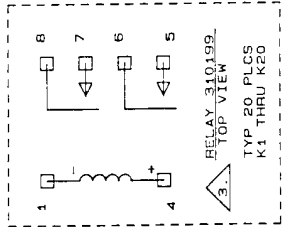

REF. DES.	IC TYPE	PIN NO.	GND PIN NO.
U17, 21, 25	2B03	9	
U16, 20, 24	74HCT273	20	10
U14	74HCT65	15	8
U13	74LS138	16	8
U11, 12, 15, 19, 23	74HCT164	14	7
U10, 18, 22, 26	74HCT166	16	8
U9	LM339	3	12
U7, 8	26LS32	16	8
U6	26LS31	16	8
U4, 5	74HCT253	16	8
U3	231154 (22V10H)	28	14
U2	231153 (16R4)	20	10
U1	231152 (16LBQ)	20	10
	IC	+5V	GND
	TYPE		PIN NO.

IC POWER AND GROUND CONNECTIONS

Z8
W1
U26
S3
P2
L5
K20
J201
C116
HIGHEST REF. DES.

- 4. C5 AND C6 ARE NOT INSTALLED.
 - 3. RELAYS K1 THRU K20 ARE RACAL P/N 310199.
ALL RELAYS SHOWN IN DE-ENERGIZED POSITION.
 - 2. RESISTOR NETWORKS ARE IN OHMS.
 - 1. CAPACITOR VALUES ARE IN MICROFARADS, 50V, +/-20%
- NOTES: UNLESS OTHERWISE SPECIFIED

PROPRIETARY NOTICE
THIS DOCUMENT AND THE TECHNICAL DATA HEREIN DISCLOSED ARE PROPRIETARY TO RACAL INSTRUMENTS INC. AND SHALL NOT, WITHOUT THE EXPRESS WRITTEN PERMISSION OF RACAL INSTRUMENTS INC. BE REPRODUCED, COPIED, OR TRANSMITTED IN ANY FORM OR BY ANY MEANS, ELECTRONIC OR MECHANICAL, INCLUDING PHOTOCOPYING, RECORDING, OR BY ANY INFORMATION STORAGE AND RETRIEVAL SYSTEM. NO PART OF THIS DOCUMENT OR IN ANY PART OR USED TO SOLICIT QUOTATIONS FROM A COMPETITIVE SOURCE OR USED FOR MANUFACTURE BY ANYONE OTHER THAN RACAL INSTRUMENTS INC. THE PRIVATE INFORMATION CONTAINED HEREIN IS UNCLASSIFIED AND IS NOT TO BE RELEASED OR EVALUATED AND FOR INCORPORATION INTO TECHNICAL SPECIFICATIONS AND OTHER DOCUMENTS WHICH SPECIFY REQUIREMENT OF PRODUCTS FROM RACAL INSTRUMENTS INC.

Racal Instruments, Inc.	
4 Goodyear St., Irvine, CA. 92718-2002	
DOCUMENT TITLE	
SCHEM., 1260-20 OPTION	
POWER SWITCH	
SIZE	DOCUMENT NO.
B	4 31919
REV	REV
A	A
SCALE	SHEET 1 OF 10

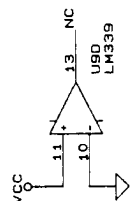
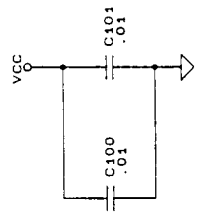
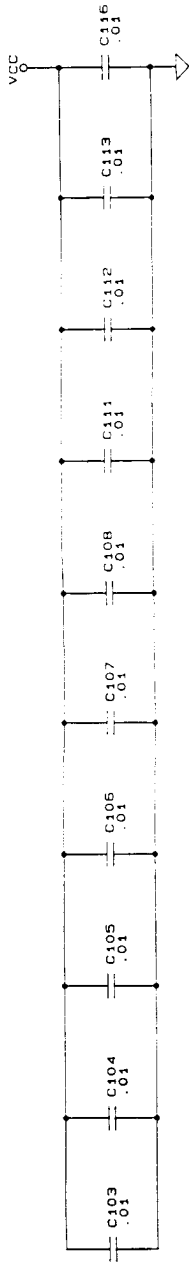

SIZE	CODE IDENT NO.	DOCUMENT NO.	REV.
B	21793	431919	A
SCALE		SHEET 2	OF 10

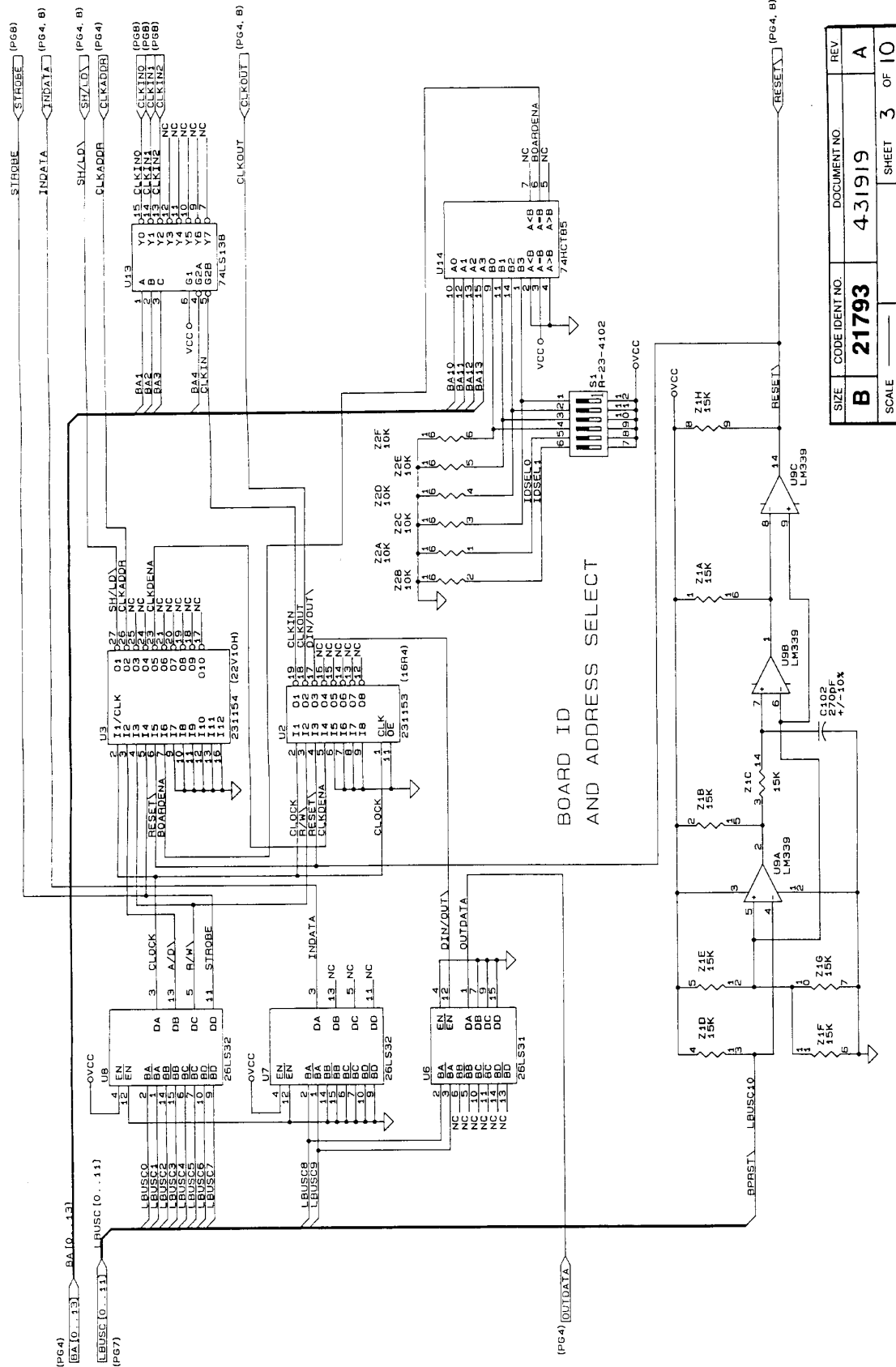

SIZE	CODE IDENT NO.	DOCUMENT NO.	REV
B	21793	4-31919	A
SCALE		SHEET 3	OF 10

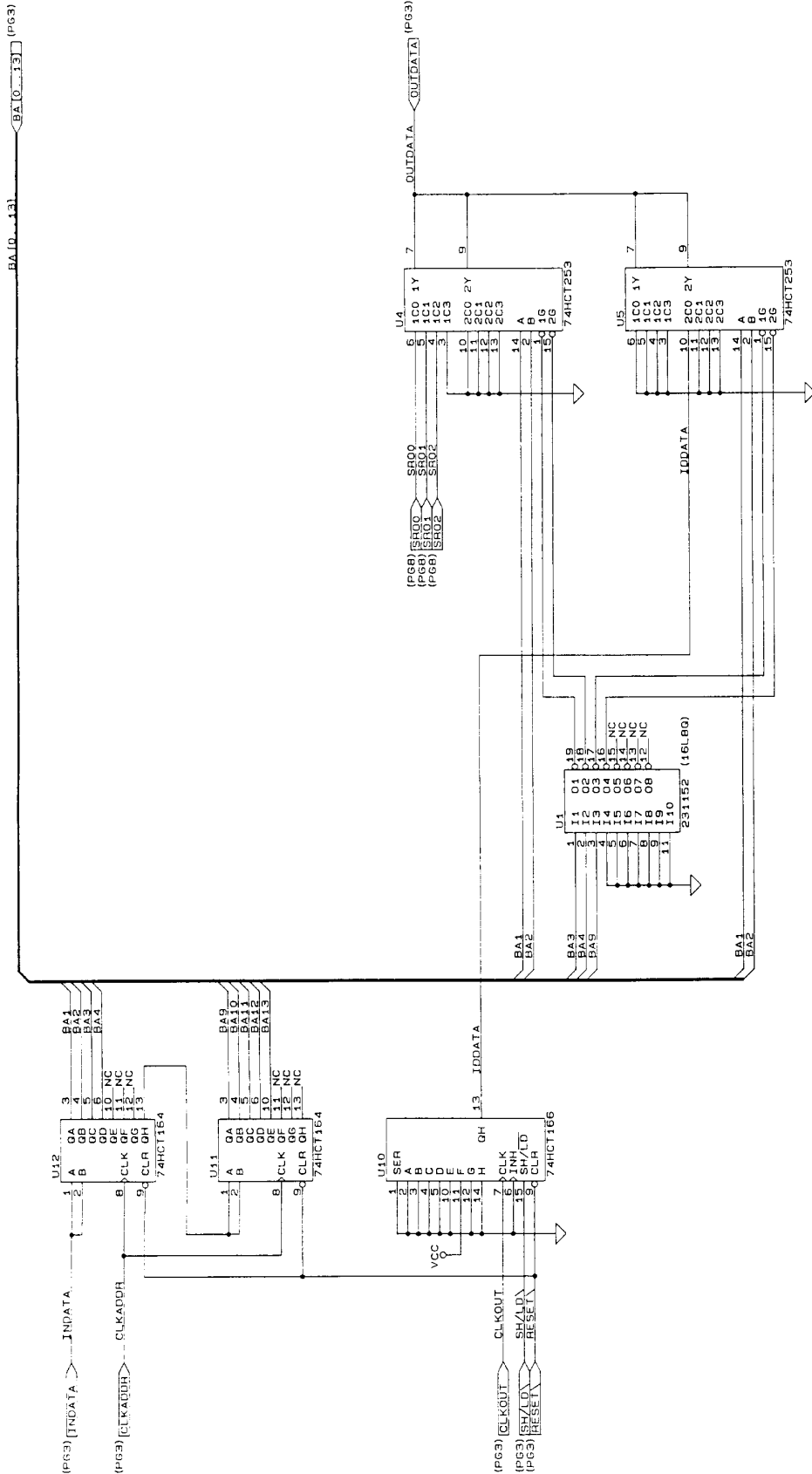

BA10...13 (PG3)

SIZE	CODE IDENT NO.	DOCUMENT NO.	REV.
B	21793	4-31919	A
SCALE		SHEET 4	OF 10

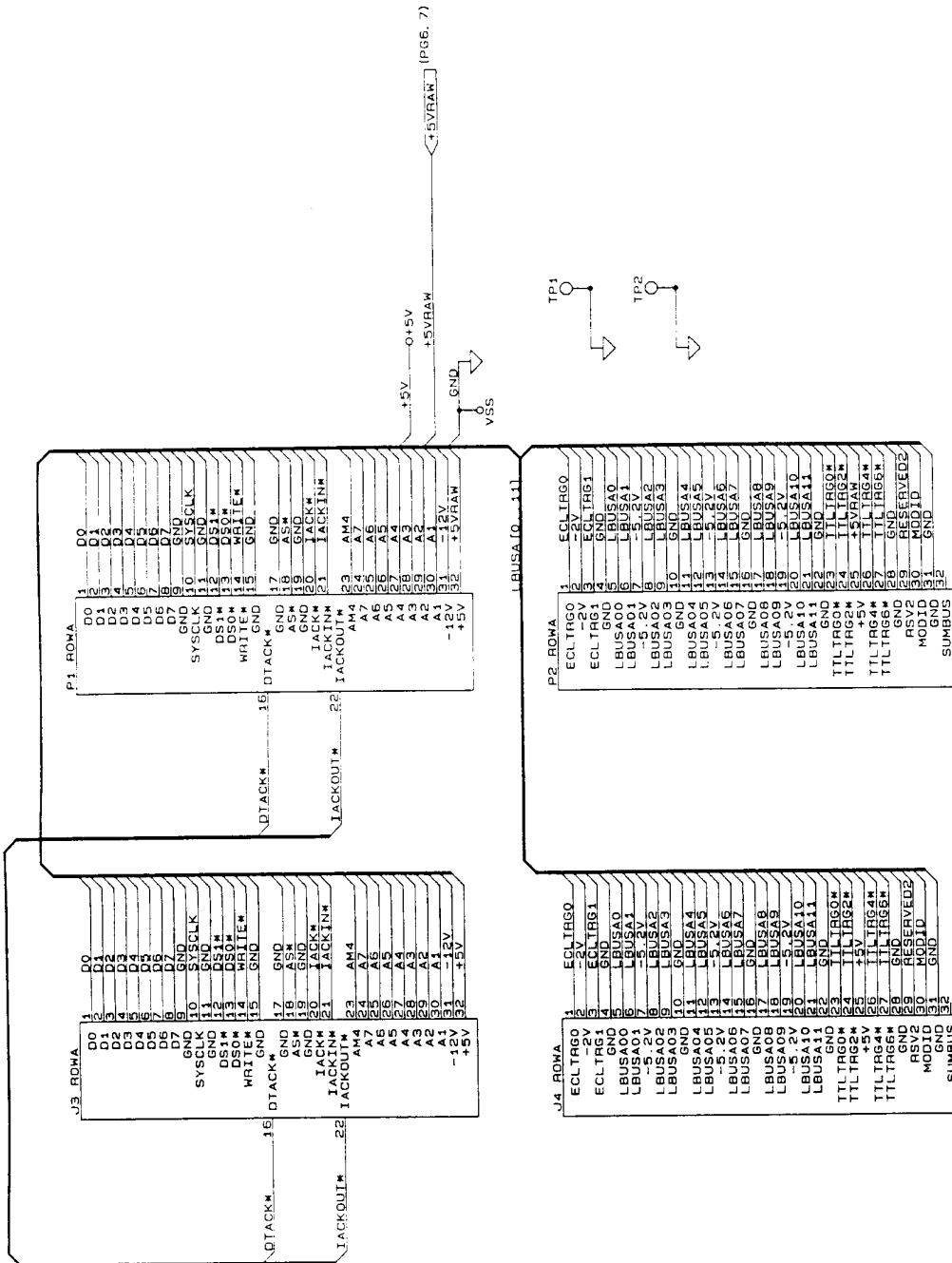

SIZE	CODE IDENT NO	DOCUMENT NO	REV
B	21793	431919	A
SCALE		SHEET 5	OF 10

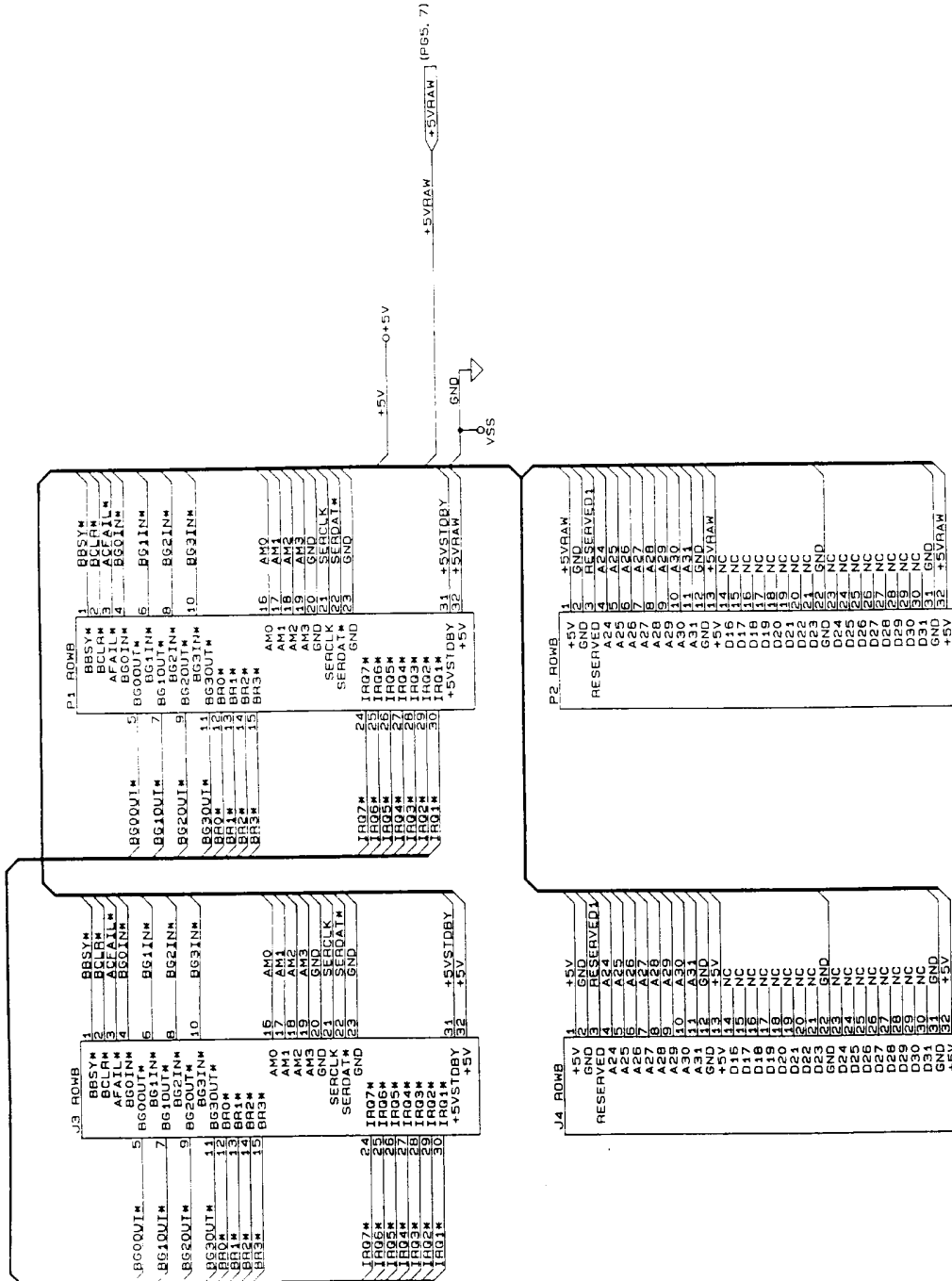

SIZE	CODE IDENT NO	DOCUMENT NO	REV.
B	21793	431919	A
SCALE		SHEET 6	OF 10

RELAY VOLTAGE SELECTOR

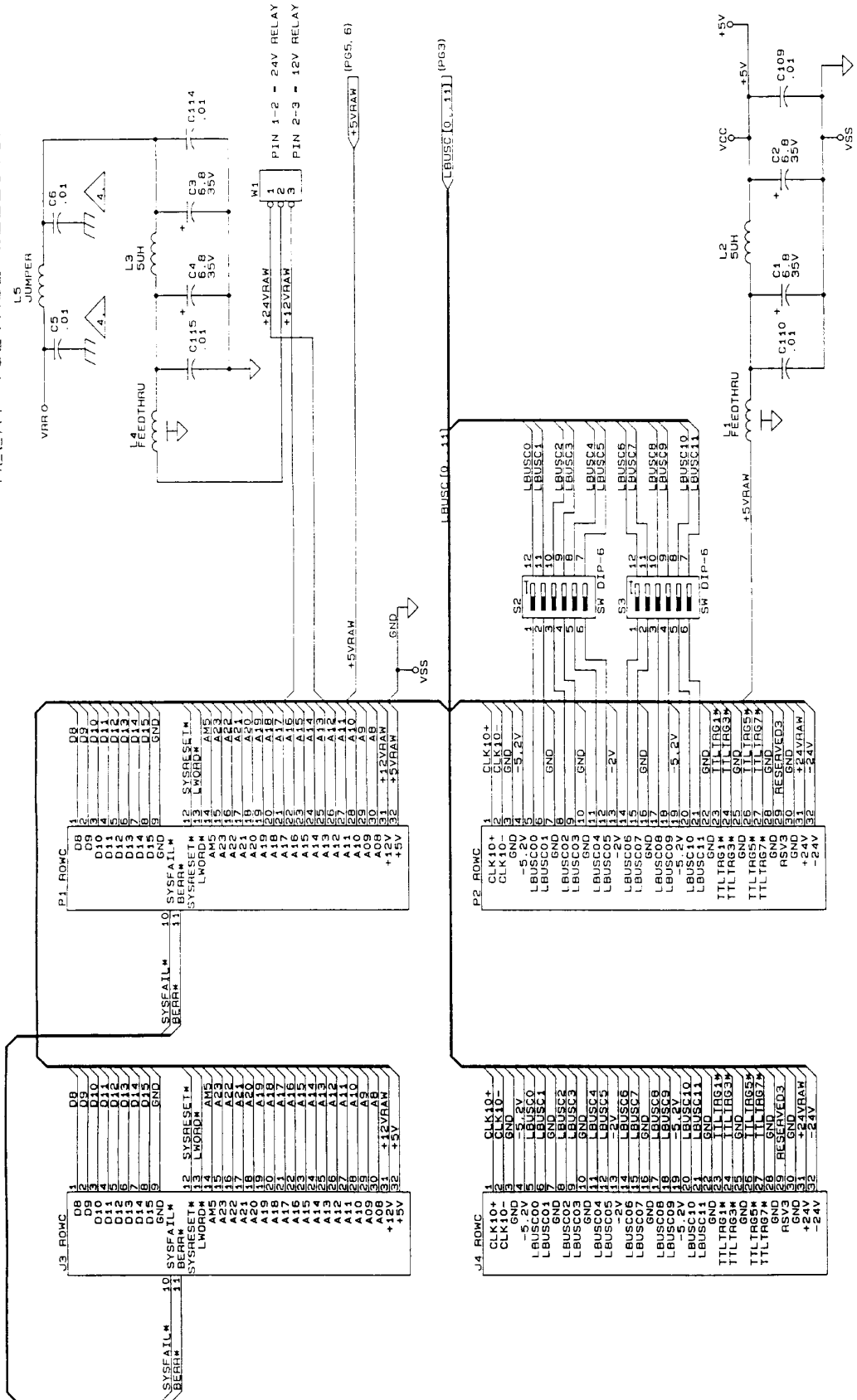

SIZE	CODE IDENT NO.	DOCUMENT NO.	REV.
B	21793	4-31919	A
SCALE		SHEET 7	OF 10

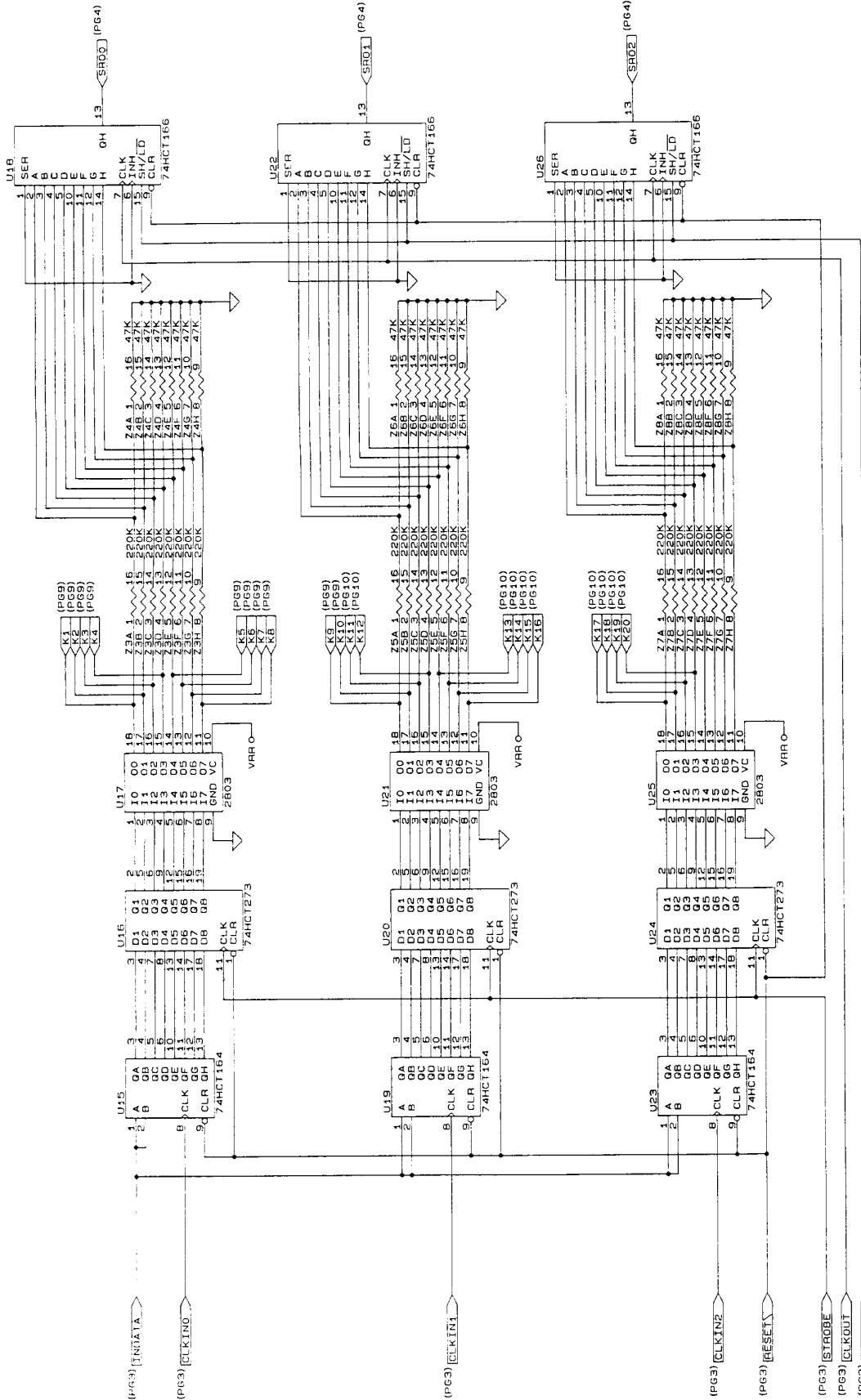

SIZE	CODE IDENT NO.	DOCUMENT NO.	REV
B	21793	4-31919	A
SCALE		SHEET 8	OF 10

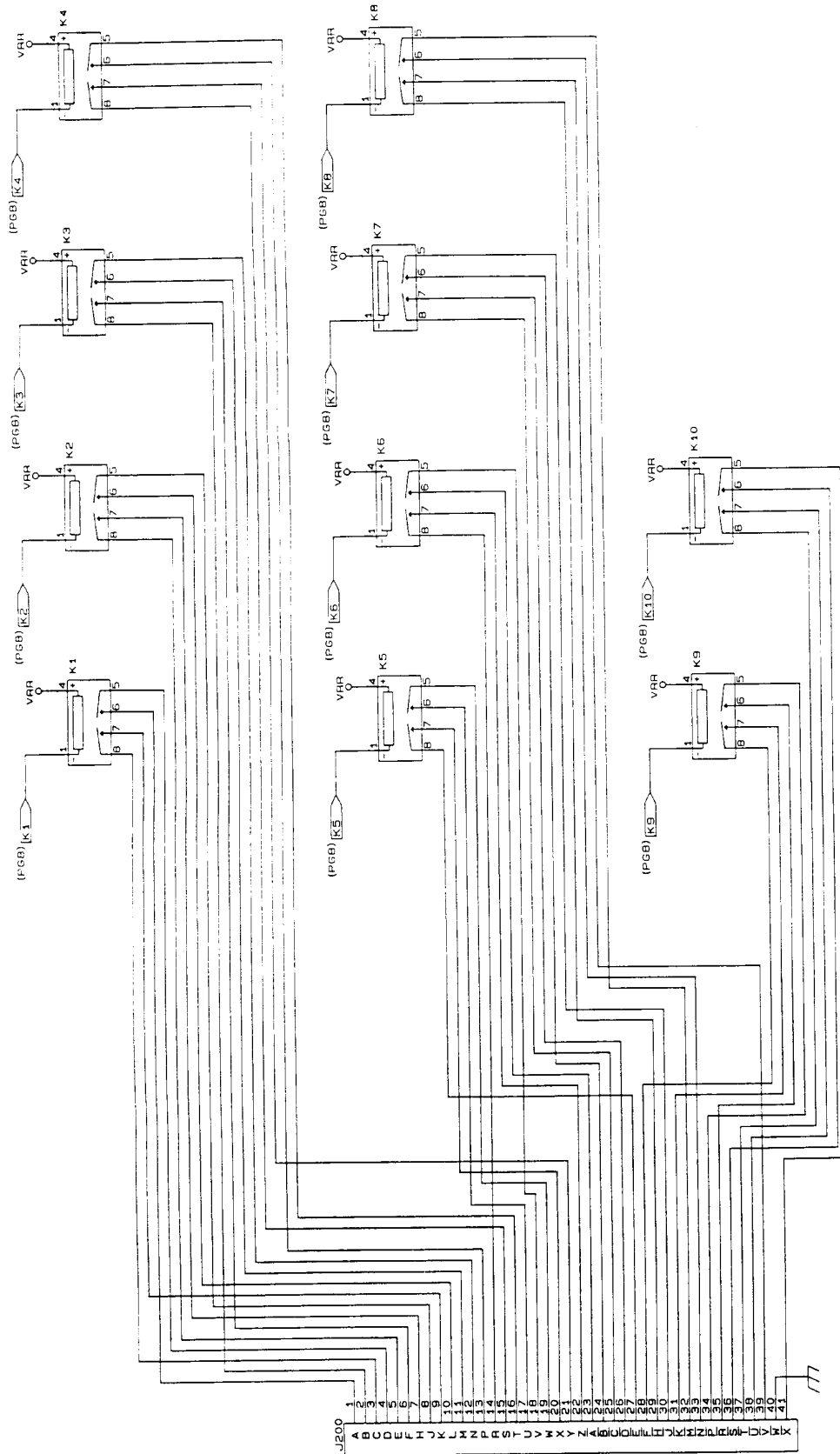

SIZE	CODE IDENT NO.	DOCUMENT NO.	REV.
B	21793	431919	A
SCALE		SHEET 9	OF 10

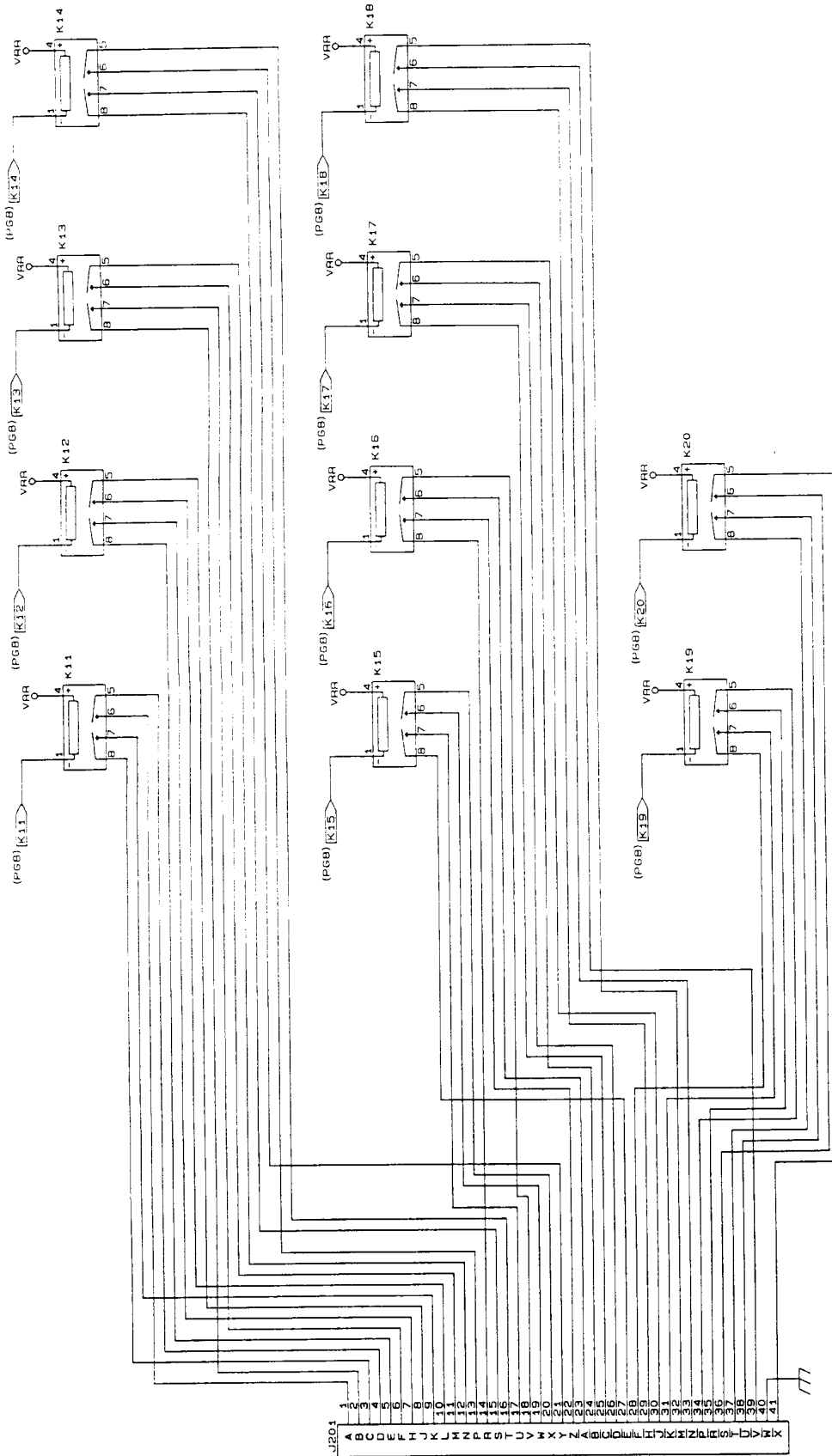

SIZE	CODE IDENT NO	DOCUMENT NO	REV
B	21793	4-31919	A
SCALE		SHEET 10	OF 10

Chapter 5

PARTS LIST

404773	Final Assembly, 1260-20	5-3
404935	Shipping Kit, 1260-20	5-3
401919	PCB Assy, 1260-20	5-4
	List of Suppliers.....	5-6

This page was left intentionally blank.

User Manual 1260-20

404773 - FINAL ASSY., 1260-20

REF DESIG	RACAL P/N	INST {	DESCRIPTION	FSC	MANUFACTURER'S P/N
{1}1	401919		PCB ASSY., 1260-20	21793	401919
{2}1	404935		SHIPPING KIT, 1260-20	21793	404935
{3}1	455523-001		PANEL, FRONT, 1260-20	21793	455523-001
{4}1	455524		COVER, BOTTOM	21793	455524
{5}1	455525		COVER, TOP	21793	455525
{8}1	611264		HANDLE, EXTRACTOR, BOTTOM	62559	20817-327
{9}1	611265		HANDLE, EXTRACTOR, TOP	62559	20817-328
{10}.5	611266		MOUNTING HARDWARE, HANDLE	62559	21100-745
{11}10	617101		WASHER, FLAT, LIGHT SERIES, #2	-	-
{12}10	615014		SCREW, PPH, 2-56 X .250	-	-
{13}3	615049		SCREW, PPH, 4-40 X .875	-	-
{14}6	615512		SCREW, PFH, 2-56X.188	-	-
{15}10	617126		WASHER, LOCK, #2, LIGHT SERIES	-	-
{16}3	617127		WASHER, LOCK, #4, LIGHT SERIES	-	-
{19}1	921148-001		LABEL SET VXI	21793	921148-001
{21}1	921059		LABEL, CAUTION, STATIC	21793	921059
{24}1	921212-003		LABEL, VXI, 1260-20	21793	921212-003
{26}1	921309		LABEL, VXI SWITCH ID	21793	921309

404935 - SHIPPING KIT, 1260-20

REF DESIG	RACAL P/N	INST {	DESCRIPTION	FSC	MANUFACTURER'S P/N
{3}2	455540		KEY, LOCKOUT, TTL, A/C	21793	455540
{4}2	455541		KEY, LOCKOUT, TTL, A/C	21793	455541
{5}2	455542		KEY, LOCKOUT, TTL, A/C	21793	455542
{7}82	601849		TERMINAL, SOLDER	28198	FS116N2
{8}2	601850		CONNECTOR, CAB. RECEPT, 41 PIN	28198	41FOE100JO
{10}3	615014		SCREW, PPH, 2-56 X .250	-	-

401919 - PCB ASSY, 1260-20 OPT.

REF	RACAL INST	DESCRIPTION	FSC	MANUFACTURER'S P/N
DESIG	P/N			
C1-C4	110126	CAP, TANTA, 6.8UF, 35V, 20 PERCENT	05397	T355F685M035A5
C100	R-21-1801	CAP, CHIP, 10 NF	195275	1VJ1206Y103MF
C101	R-21-1801	CAP, CHIP, 10 NF	195275	1VJ1206Y103MF
C102	130177	CAPACITOR, CHIP, SMD, 270PF	195275	1VJ1206A271KXAMT
C103-C116	R-21-1801	CAP, CHIP, 10 NF	195275	1VJ1206Y103MF
J3	1601925	CONNECTOR, PCB, RECEPT, 3 ROW, 96P	152072	1618008
J4	1601925	CONNECTOR, PCB, RECEPT, 3 ROW, 96P	152072	1618008
J200	1601851	CONNECTOR, PCB, PLUG, 41 PIN	128198	1GAPL41MOTOLB
J201	1601851	CONNECTOR, PCB, PLUG, 41 PIN	128198	1GAPL41MOTOLB
K1-K20	1310199	RELAY, POWER, 2 FORM A	161529	1ST2E-DC24V
L1	1100164	CAP, FEED-THRU, 800PF, 50V	100779	1842448-2
L2	1310193	CHOKER, SHIELDED, 5UH	191637	1IH-5-5-10
L3	1310193	CHOKER, SHIELDED, 5UH	191637	1IH-5-5-10
L4	1100164	CAP, FEED-THRU, 800PF, 50V	100779	1842448-2
L5	1600245	JUMPER, INSULATED	152210	1L-2007-1
P1	1601675	CONNECTOR, EUROCARD TYPE C, 96-PIN	100779	1532505-1
P2	1601675	CONNECTOR, EUROCARD TYPE C, 96-PIN	100779	1532505-1
S1	1600814	SWITCH, SLIDE, 6SPST	102660	131-010
S2	1601915	SWITCH, DIP 6 POS, SMD	191506	1ADF-06ST
S3	1601915	SWITCH, DIP 6 POS, SMD	191506	1ADF-06ST
TP1	1601197	POST, TEST, .025 SQ	100779	16-87022-6
TP2	1601197	POST, TEST, .025 SQ	100779	16-87022-6
U1	1231152	IC, PROGRAMMED PIA	121793	1231152
U2	1231153	IC, PROGRAMMED PLA	121793	1231153
U3	1231154	IC, PROGRAMMED PLA	121793	1231154
U4	1231147	IC, MULTIPLEXER	104713	174HC253D
U5	1231147	IC, MULTIPLEXER	104713	174HC253D
U6	1231125	IC, DIGITAL, LINE DRIVER	127014	1DS26LS31MN
U7	1231096	IC, QUAD DIFF RECEIVER	101295	1AM26LS32ACD
U8	1231096	IC, QUAD DIFF RECEIVER	101295	1AM26LS32ACD
U9	1231093	IC, QUAD COMPARATOR	104713	1LM339D
U10	1231120	IC, 8-BIT, PARALLEL/SERIAL OUT S.R.	118324	174HCT166D
U11	1231131	IC, DIGITAL, SHIFT REGISTER	118324	1PC74HCT164D
U12	1231131	IC, DIGITAL, SHIFT REGISTER	118324	1PC74HCT164D
U13	1231094	IC, DEMUX DECODER	118324	1N74LS138D
U14	1231135	IC, DIGITAL, 4-BIT COMPARATOR	118324	1PC74HCT85D
U15	1231131	IC, DIGITAL, SHIFT REGISTER	118324	1PC74HCT164D
U16	1231130	IC, DIGITAL, FLIP FLOP	118324	1PC74HC273
U17	1231098	IC, SOIC TRANSISTOR	156289	1ULN-2803LW
U18	1231120	IC, 8-BIT, PARALLEL/SERIAL OUT S.R.	118324	174HCT166D
U19	1231131	IC, DIGITAL, SHIFT REGISTER	118324	1PC74HCT164D
U20	1231130	IC, DIGITAL, FLIP FLOP	118324	1PC74HC273
U21	1231098	IC, SOIC TRANSISTOR	156289	1ULN-2803LW
U22	1231120	IC, 8-BIT, PARALLEL/SERIAL OUT S.R.	118324	174HCT166D
U23	1231131	IC, DIGITAL, SHIFT REGISTER	118324	1PC74HCT164D
U24	1231130	IC, DIGITAL, FLIP FLOP	118324	1PC74HC273
U25	1231098	IC, SOIC TRANSISTOR	156289	1ULN-2803LW
U26	1231120	IC, 8-BIT, PARALLEL/SERIAL OUT S.R.	118324	174HCT166D
Z1	1080114	RES NETWORK, 16P8R, 15K	173138	1628-AL-153J
Z2	1080120	RES NETWORK, 10K	111236	1767-161R10K
Z3	1080119	RES NETWORK, 220K	191637	1SOMC-1603-224K
Z4	1080117	RES NETWORK, 16P8R, 47K	173138	1628-AL-473J
Z5	1080119	RES NETWORK, 220K	191637	1SOMC-1603-224K
Z6	1080117	RES NETWORK, 16P8R, 47K	173138	1628-AL-473J
Z7	1080119	RES NETWORK, 220K	191637	1SOMC-1603-224K
Z8	1080117	RES NETWORK, 16P8R, 47K	173138	1628-AL-473J
{41}1	1401951	PCB ASSY., LBUS JUMPER	121793	1401951
{42}1	1401951-003	PCB ASSY., P3 JUMPER	121793	1401951-003
{43}1	1411919	PCB, POWER MODULE (UNLOADED)	121793	1411919

User Manual 1260-20

401919 - PCB ASSY, 1260-20 OPT.

REF DESIG	RACAL INST P/N	DESCRIPTION	FSC	MANUFACTURER'S P/N
{46}A/R	1500022	WIRE, BARE COPPER/TIN, 22 GA	121793	1500022
{58}3	1611227	SPACER, PRESS, #4, PCB	146384	1KFSE-116-20
{59}4	1615027	SCREW, PPH, 3-48 X .188	-	-
{61}A/R	1920962	LOCTITE, 242, MED STR.	105972	1272
{66}A/R	1921279	LOCQUIC, PRIMER	105972	174756
{67}A/R	1921280	LOCTITE, HIGH STRENGTH	105972	1271

List of Suppliers

FSC	SUPPLIER
00779	AMP, INC. HARRISBURG, PA
01295	TEXAS INSTRUMENTS, INC. DALLAS, TX
02660	AMPHENOL CORP. BROADVIEW, IL
04713	MOTOROLA, INC. (SEMICONDUCTOR PRODUCTS DIV.) PHOENIX, AZ
05397	UNION CARBIDE CORP. (MATERIALS SYSTEMS DIV.) CLEVELAND, OH
05972	LOCTITE CORP. HARTFORD, CT
11236	CTS OF BERNE, INC. BERNE, IN
18324	SIGNETICS, INC. SUNNYVALE, CA
21793	RACAL INSTRUMENTS INC. IRVINE, CA
27014	NATIONAL SEMI-CONDUCTOR CORP. SANTA CLARA, CA
28198	POSITRONIC INDUSTRIES INC. SPRINGFIELD, MO
46384	PENN ENG. & MFG. CORP DOYLESTOWN, PA
52072	CIRCUIT ASSY. CORP. COSTA MESA, CA
52210	GETTING ENGRG. & MFG. CO. SPRING MILLS, PA
56289	SPAGUE ELECTRIC CO. N. ADAMS, MA
61529	AROMAT CORP. CUPERTINO, CA
62559	SCHROFF, INC. WARWICK, RI
73138	BECKMAN INSTRUMENTS FULLERTON, CA
91506	AUGAT, INC. ATTLEBORO, MA
91637	DALE ELECTRONICS, INC. COLUMBUS, NE
95275	VITRAMON, INC. BRIDGEPORT, CT

Chapter 6

OPTIONAL HARNESS ASSEMBLIES

The following harness assemblies are used to connect Racal Instruments Model 1260-20 to Freedom Series Test Receiver Interfaces.

Each harness documentation consists of an assembly drawing, parts list, system wire list and wire list.

407276 Virginia Panel, Inc. Series VP90 Interface Harness

407277-005 TTI Testron, Inc. Interface Harness

407277-008 TTI Testron, Inc. Interface Harness

For more information on Racal Instruments complete line of Test Receivers Interface solution, contact your Sales Representative.

This page was left intentionally blank.

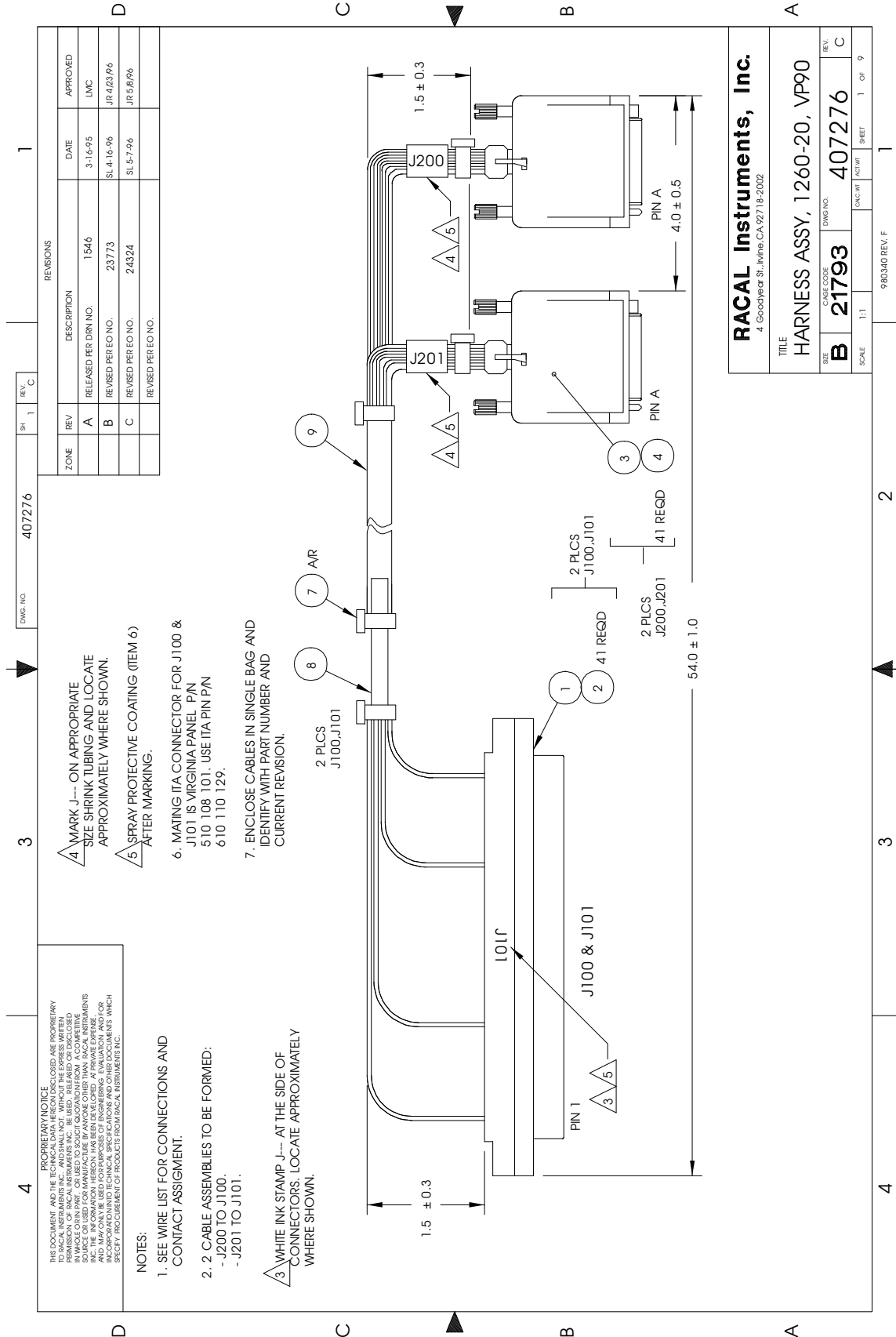

ZONE	REV	DESCRIPTION	DATE	APPROVED
	A	RELEASED PER DRN NO. 1546	3-16-95	LMC
	B	REVISED PER O NO. 23773	SL 4-16-96	JR 4/23/96
	C	REVISED PER O NO. 24324	SL 5-7-96	JR 5/8/96
		REVISED PER O NO.		

REV	DATE	DESCRIPTION
1	1	1

ZONE	REV	DESCRIPTION	DATE	APPROVED
	A	RELEASED PER DRN NO. 1546	3-16-95	LMC
	B	REVISED PER O NO. 23773	SL 4-16-96	JR 4/23/96
	C	REVISED PER O NO. 24324	SL 5-7-96	JR 5/8/96
		REVISED PER O NO.		

PROPRIETARY NOTICE
 THIS DOCUMENT AND THE TECHNICAL DATA HEREON DISCLOSED ARE PROPRIETARY INFORMATION OF RACAL INSTRUMENTS INC. BE USED, REPRODUCED OR DISCLOSED IN ANY MANNER WITHOUT THE WRITTEN PERMISSION OF RACAL INSTRUMENTS INC. THIS INFORMATION HEREON HAS BEEN DEVELOPED AT PRIVATE EXPENSE AND MAY ONLY BE USED FOR PURPOSES OF ENGINEERING EVALUATION AND FOR SPECIFYING REQUIREMENTS OF PRODUCTS FROM RACAL INSTRUMENTS INC.

- NOTES:
- SEE WIRE LIST FOR CONNECTIONS AND CONTACT ASSIGNMENT.
 - 2 CABLE ASSEMBLIES TO BE FORMED:
 - J200 TO J100.
 - J201 TO J101.
 - WHITE INK STAMP J-- AT THE SIDE OF CONNECTORS. LOCATE APPROXIMATELY WHERE SHOWN.
 - MARK J-- ON APPROPRIATE SIZE SHRINK TUBING AND LOCATE APPROXIMATELY WHERE SHOWN.
 - SPRAY PROTECTIVE COATING (ITEM 6) AFTER MARKING.
 - MATING ITA CONNECTOR FOR J100 & J101 IS VIRGINIA PANEL P/N 510 108 101. USE ITA PIN P/N 610 110 129.
 - ENCLOSE CABLES IN SINGLE BAG AND IDENTIFY WITH PART NUMBER AND CURRENT REVISION.

RACAL Instruments, Inc. 4 Goodhyer St. Milpitas, CA 95035	
TITLE HARNESS ASSY, 1260-20, VP90	
SIZE B	DWS NO. 407276
SCALE 1:1	SHEET 1 OF 9

ENGINEERING WIRE LIST

WIRE	FROM	TO	TYPE	PART #	WIRE LEN	REFERENCE
1	J100-1 602201-905	J200-A 602200	20 AWG WHT	520999	54"	CHANNEL 00 IN HI
2	J100-33 602201-905	J200-C 602200	20 AWG WHT	520999	54"	CHANNEL 00 IN LO
3	J100-2 602201-905	J200-D 602200	20 AWG WHT	520999	54"	CHANNEL 00 OUT HI
4	J100-34 602201-905	J200-K 602200	20 AWG WHT	520999	54"	CHANNEL 00 OUT LO
5	J100-3 602201-905	J200-E 602200	20 AWG WHT	520999	54"	CHANNEL 01 IN HI
6	J100-35 602201-905	J200-J 602200	20 AWG WHT	520999	54"	CHANNEL 01 IN LO
7	J100-4 602201-905	J200-H 602200	20 AWG WHT	520999	54"	CHANNEL 01 OUT HI
8	J100-36 602201-905	J200-L 602200	20 AWG WHT	520999	54"	CHANNEL 01 OUT LO
9	J100-5 602201-905	J200-B 602200	20 AWG WHT	520999	54"	CHANNEL 02 IN HI
10	J100-37 602201-905	J200-M 602200	20 AWG WHT	520999	54"	CHANNEL 02 IN LO
11	J100-6 602201-905	J200-F 602200	20 AWG WHT	520999	54"	CHANNEL 02 OUT HI
12	J100-38 602201-905	J200-N 602200	20 AWG WHT	520999	54"	CHANNEL 02 OUT LO
13	J100-7 602201-905	J200-P 602200	20 AWG WHT	520999	54"	CHANNEL 03 IN HI
14	J100-39 602201-905	J200-S 602200	20 AWG WHT	520999	54"	CHANNEL 03 IN LO
15	J100-8 602201-905	J200-T 602200	20 AWG WHT	520999	54"	CHANNEL 03 OUT HI
16	J100-40 602201-905	J200-Y 602200	20 AWG WHT	520999	54"	CHANNEL 03 OUT LO
17	J100-9 602201-905	J200-U 602200	20 AWG WHT	520999	54"	CHANNEL 04 IN HI
18	J100-41 602201-905	J200-X 602200	20 AWG WHT	520999	54"	CHANNEL 04 IN LO
19	J100-10 602201-905	J200-W 602200	20 AWG WHT	520999	54"	CHANNEL 04 OUT HI
20	J100-42 602201-905	J200-e 602200	20 AWG WHT	520999	54"	CHANNEL 04 OUT LO
21	J100-11 602201-905	J200-V 602200	20 AWG WHT	520999	54"	CHANNEL 05 IN HI
22	J100-43 602201-905	J200-R 602200	20 AWG WHT	520999	54"	CHANNEL 05 IN LO
23	J100-12 602201-905	J200-a 602200	20 AWG WHT	520999	54"	CHANNEL 05 OUT HI
24	J100-44 602201-905	J200-Z 602200	20 AWG WHT	520999	54"	CHANNEL 05 OUT LO
25	J100-13 602201-905	J200-b 602200	20 AWG WHT	520999	54"	CHANNEL 06 IN HI

DOC. NO. 407276

RACAL Instruments, Inc., 4 Goodyear St., Irvine, CA 92718

DOCUMENT TITLE	SIZE	CODE NO.	DOCUMENT NO.	REV
HARNESS ASSY, 1260-20, VP90	A	21793	407276	C
	DRN			SHEET 4 of 9

ENGINEERING WIRE LIST

WIRE	FROM	TO	TYPE	PART #	WIRE LEN	REFERENCE
26	J100-45 602201-905	J200-c 602200	20 AWG WHT	520999	54"	CHANNEL 06 IN LO
27	J100-14 602201-905	J200-j 602200	20 AWG WHT	520999	54"	CHANNEL 06 OUT HI
28	J100-46 602201-905	J200-d 602200	20 AWG WHT	520999	54"	CHANNEL 06 OUT LO
29	J100-15 602201-905	J200-m 602200	20 AWG WHT	520999	54"	CHANNEL 07 IN HI
30	J100-47 602201-905	J200-n 602200	20 AWG WHT	520999	54"	CHANNEL 07 IN LO
31	J100-16 602201-905	J200-v 602200	20 AWG WHT	520999	54"	CHANNEL 07 OUT HI
32	J100-48 602201-905	J200-h 602200	20 AWG WHT	520999	54"	CHANNEL 07 OUT LO
33	J100-17 602201-905	J200-p 602200	20 AWG WHT	520999	54"	CHANNEL 08 IN HI
34	J100-49 602201-905	J200-f 602200	20 AWG WHT	520999	54"	CHANNEL 08 IN LO
35	J100-18 602201-905	J200-r 602200	20 AWG WHT	520999	54"	CHANNEL 08 OUT HI
36	J100-50 602201-905	J200-k 602200	20 AWG WHT	520999	54"	CHANNEL 08 OUT LO
37	J100-19 602201-905	J200-x 602200	20 AWG WHT	520999	54"	CHANNEL 09 IN HI
38	J100-51 602201-905	J200-t 602200	20 AWG WHT	520999	54"	CHANNEL 09 IN LO
39	J100-20 602201-905	J200-s 602200	20 AWG WHT	520999	54"	CHANNEL 09 OUT HI
40	J100-52 602201-905	J200-u 602200	20 AWG WHT	520999	54"	CHANNEL 09 OUT LO
41	J100-21 602201-905	J200-w 602200	20 AWG WHT	520999	54"	CHASSIS GND
42	J100-53 NO CONNECT					
43	J100-22 NO CONNECT					
44	J100-54 NO CONNECT					
45	J100-23 NO CONNECT					
46	J100-55 NO CONNECT					
47	J100-24 NO CONNECT					
48	J100-56 NO CONNECT					
49	J100-25 NO CONNECT					
50	J100-57 NO CONNECT					

DOC. NO. 407276

RACAL Instruments, Inc., 4 Goodyear St., Irvine, CA 92718

DOCUMENT TITLE		SIZE	CODE NO.	DOCUMENT NO.	REV
HARNESS ASSY, 1260-20, VP90		A	21793	407276	C
DRN			SHEET 5 of 9		

ENGINEERING WIRE LIST

WIRE	FROM	TO	TYPE	PART #	WIRE LEN	REFERENCE
51	J100-26 NO CONNECT					
52	J100-58 NO CONNECT					
53	J100-27 NO CONNECT					
54	J100-59 NO CONNECT					
55	J100-28 NO CONNECT					
56	J100-60 NO CONNECT					
57	J100-29 NO CONNECT					
58	J100-61 NO CONNECT					
59	J100-30 NO CONNECT					
60	J100-62 NO CONNECT					
61	J100-31 NO CONNECT					
62	J100-63 NO CONNECT					
63	J100-32 NO CONNECT					
64	J100-64 NO CONNECT					
65	J101-1 602201-905	J201-A 602200	20 AWG WHT	520999	54"	CHANNEL 10 IN HI
66	J101-33 602201-905	J201-C 602200	20 AWG WHT	520999	54"	CHANNEL 10 IN LO
67	J101-2 602201-905	J201-D 602200	20 AWG WHT	520999	54"	CHANNEL 10 OUT HI
68	J101-34 602201-905	J201-K 602200	20 AWG WHT	520999	54"	CHANNEL 10 OUT LO
69	J101-3 602201-905	J201-E 602200	20 AWG WHT	520999	54"	CHANNEL 11 IN HI
70	J101-35 602201-905	J201-J 602200	20 AWG WHT	520999	54"	CHANNEL 11 IN LO
71	J101-4 602201-905	J201-H 602200	20 AWG WHT	520999	54"	CHANNEL 11 OUT HI
72	J101-36 602201-905	J201-L 602200	20 AWG WHT	520999	54"	CHANNEL 11 OUT LO
73	J101-5 602201-905	J201-B 602200	20 AWG WHT	520999	54"	CHANNEL 12 IN HI
74	J101-37 602201-905	J201-M 602200	20 AWG WHT	520999	54"	CHANNEL 12 IN LO
75	J101-6 602201-905	J201-F 602200	20 AWG WHT	520999	54"	CHANNEL 12 OUT HI

DOC NO. 407276

RACAL Instruments, Inc., 4 Goodyear St., Irvine, CA 92718

DOCUMENT TITLE:		SIZE	CODE NO.	DOCUMENT NO.	REV
HARNESS ASSY, 1260-20, VP90		A	21793	407276	C
DRN			SHEET 6 of 9		

ENGINEERING WIRE LIST

WIRE	FROM	TO	TYPE	PART #	WIRE LEN	REFERENCE
76	J101-38 602201-905	J201-N 602200	20 AWG WHT	520999	54"	CHANNEL 12 OUT LO
77	J101-7 602201-905	J201-P 602200	20 AWG WHT	520999	54"	CHANNEL 13 IN HI
78	J101-39 602201-905	J201-S 602200	20 AWG WHT	520999	54"	CHANNEL 13 IN LO
79	J101-8 602201-905	J201-T 602200	20 AWG WHT	520999	54"	CHANNEL 13 OUT HI
80	J101-40 602201-905	J201-Y 602200	20 AWG WHT	520999	54"	CHANNEL 13 OUT LO
81	J101-9 602201-905	J201-U 602200	20 AWG WHT	520999	54"	CHANNEL 14 IN HI
82	J101-41 602201-905	J201-X 602200	20 AWG WHT	520999	54"	CHANNEL 14 IN LO
83	J101-10 602201-905	J201-e 602200	20 AWG WHT	520999	54"	CHANNEL 14 OUT HI
84	J101-42 602201-905	J201-W 602200	20 AWG WHT	520999	54"	CHANNEL 14 OUT LO
85	J101-11 602201-905	J201-V 602200	20 AWG WHT	520999	54"	CHANNEL 15 IN HI
86	J101-43 602201-905	J201-R 602200	20 AWG WHT	520999	54"	CHANNEL 15 IN LO
87	J101-12 602201-905	J201-a 602200	20 AWG WHT	520999	54"	CHANNEL 15 OUT HI
88	J101-44 602201-905	J201-Z 602200	20 AWG WHT	520999	54"	CHANNEL 15 OUT LO
89	J101-13 602201-905	J201-b 602200	20 AWG WHT	520999	54"	CHANNEL 16 IN HI
90	J101-45 602201-905	J201-c 602200	20 AWG WHT	520999	54"	CHANNEL 16 IN LO
91	J101-14 602201-905	J201-j 602200	20 AWG WHT	520999	54"	CHANNEL 16 OUT HI
92	J101-46 602201-905	J201-d 602200	20 AWG WHT	520999	54"	CHANNEL 16 OUT LO
93	J101-15 602201-905	J201-m 602200	20 AWG WHT	520999	54"	CHANNEL 17 IN HI
94	J101-47 602201-905	J201-n 602200	20 AWG WHT	520999	54"	CHANNEL 17 IN LO
95	J101-16 602201-905	J201-v 602200	20 AWG WHT	520999	54"	CHANNEL 17 OUT HI
96	J101-48 602201-905	J201-h 602200	20 AWG WHT	520999	54"	CHANNEL 17 OUT LO
97	J101-17 602201-905	J201-p 602200	20 AWG WHT	520999	54"	CHANNEL 18 IN HI
98	J101-49 602201-905	J201-f 602200	20 AWG WHT	520999	54"	CHANNEL 18 IN LO
99	J101-18 602201-905	J201-r 602200	20 AWG WHT	520999	54"	CHANNEL 18 OUT HI
100	J101-50 602201-905	J201-k 602200	20 AWG WHT	520999	54"	CHANNEL 18 OUT LO

DOC. NO. 407276

RACAL Instruments, Inc., 4 Goodyear St., Irvine, CA 92718

DOCUMENT TITLE	SIZE	CODE NO.	DOCUMENT NO.	REV
HARNESS ASSY, 1260-20, VP90	A	21793	407276	C
	DRN		SHEET 7 of 9	

ENGINEERING WIRE LIST

WIRE	FROM	TO	TYPE	PART #	WIRE LEN	REFERENCE
101	J101-19 602201-905	J201-x 602200	20 AWG WHT	520999	54"	CHANNEL 19 IN HI
102	J101-51 602201-905	J201-t 602200	20 AWG WHT	520999	54"	CHANNEL 19 IN LO
103	J101-20 602201-905	J201-s 602200	20 AWG WHT	520999	54"	CHANNEL 19 OUT HI
104	J101-52 602201-905	J201-u 602200	20 AWG WHT	520999	54"	CHANNEL 19 OUT LO
105	J101-21 602201-905	J201-w 602200	20 AWG WHT	520999	54"	CHASSIS GND
106	J101-53 NO CONNECT					
107	J101-22 NO CONNECT					
108	J101-54 NO CONNECT					
109	J101-23 NO CONNECT					
110	J101-55 NO CONNECT					
111	J101-24 NO CONNECT					
112	J101-56 NO CONNECT					
113	J101-25 NO CONNECT					
114	J101-57 NO CONNECT					
115	J101-26 NO CONNECT					
116	J101-58 NO CONNECT					
117	J101-27 NO CONNECT					
118	J101-59 NO CONNECT					
119	J101-28 NO CONNECT					
120	J101-60 NO CONNECT					
121	J101-29 NO CONNECT					
122	J101-61 NO CONNECT					
123	J101-30 NO CONNECT					
124	J101-62 NO CONNECT					
125	J101-31 NO CONNECT					
RACAL Instruments, Inc., 4 Goodyear St., Irvine, CA 92718						
DOCUMENT TITLE			SIZE	CODE NO.	DOCUMENT NO.	REV
HARNESS ASSY, 1260-20, VP90			A	21793	407276	C
			DRN	SHEET 8 of 9		

DOC. NO. 407276

ENGINEERING WIRE LIST

WIRE	FROM	TO	TYPE	PART #	WIRE LEN	REFERENCE
126	J101-63 NO CONNECT					
127	J101-32 NO CONNECT					
128	J101-64 NO CONNECT					
RACAL Instruments, Inc., 4 Goodyear St., Irvine, CA 92718						
DOCUMENT TITLE			SIZE	CODE NO.	DOCUMENT NO.	REV
HARNESS ASSY, 1260-20, VP90			A	21793	407276	C
			DRN	SHEET 9 of 9		

DOC. NO. 407276

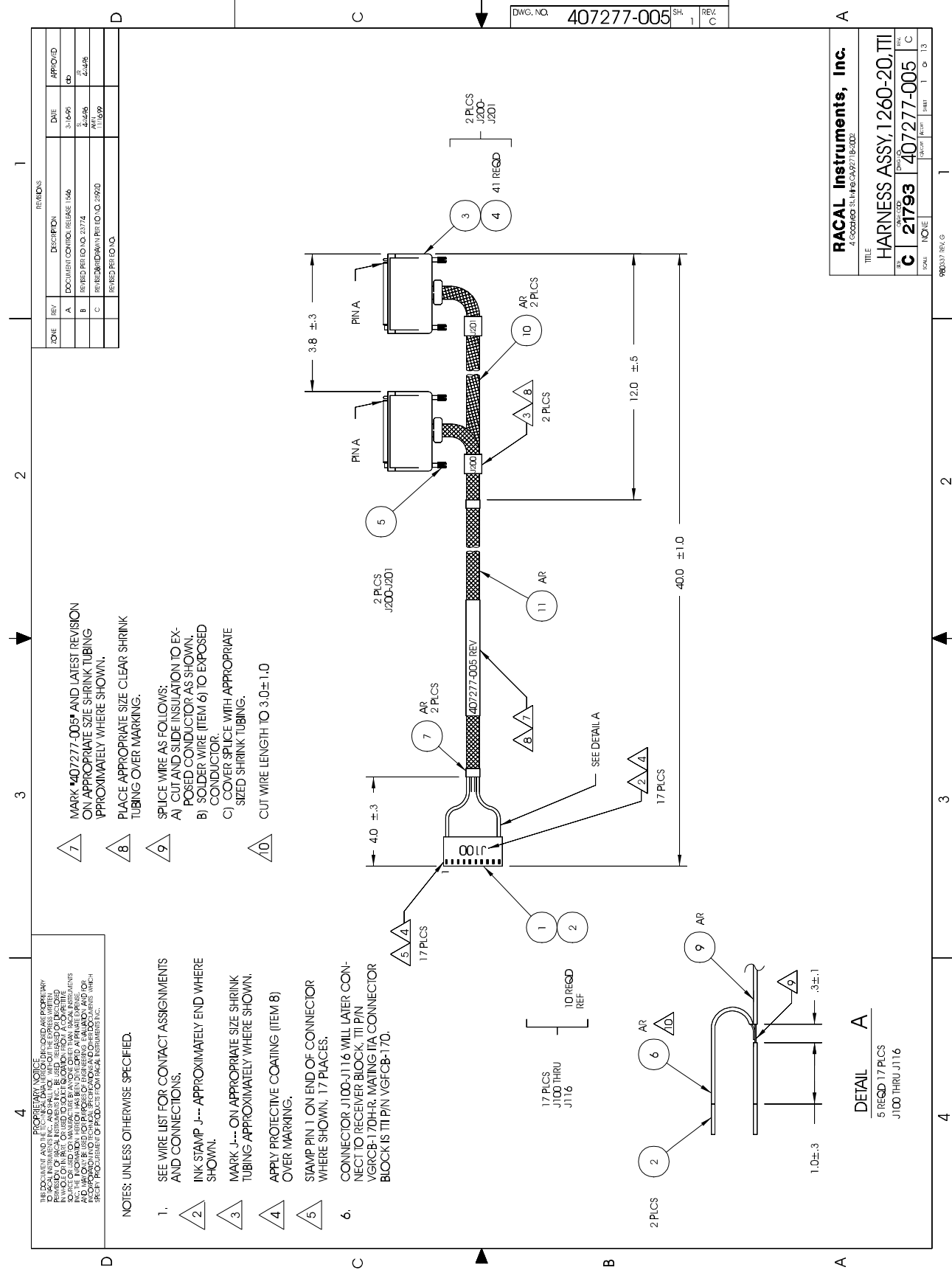

ZONE	REV	DESCRIPTION	DATE	APPRO-ID
A		DOCUMENT CONTROL RELEASE 1946	3-16-69	db
B		REVISED PER D.O. 21774	3-26-69	
C		REVISED PER D.O. 25920	11-11-69	
D		REVISED PER D.O.		

DWG. NO. 407277-005 SH. 1 REV. C

RACAL Instruments, Inc.	
4 GOSWOLD ST. HILLS COMB. 271 8-0022	
TITLE	HARNESS ASSY. 1260-20, ITI
REV.	C
DWG. NO.	407277-005
DATE	11-11-69
BY	21793
CHECKED	
APPROVED	
SCALE	NONE
SHEET	1 OF 13

PROPRIETARY NOTICE:
 THIS DOCUMENT IS THE PROPERTY OF RACAL INSTRUMENTS, INC. AND IS TO BE USED ONLY FOR THE PURPOSES SPECIFIED HEREIN. IT IS TO BE KEPT IN CONFIDENTIALITY AND NOT TO BE DISCLOSED TO ANY OTHER PERSON OR ENTITY WITHOUT THE WRITTEN PERMISSION OF RACAL INSTRUMENTS, INC. ANY UNAUTHORIZED DISCLOSURE OF THIS DOCUMENT IS STRICTLY PROHIBITED AND WILL BE SUBJECT TO LEGAL ACTION.

NOTES: UNLESS OTHERWISE SPECIFIED:

- SEE WIRE LIST FOR CONTACT ASSIGNMENTS AND CONNECTIONS.
- INK STAMP J--- APPROXIMATELY END WHERE SHOWN.
- MARK J--- ON APPROPRIATE SIZE SHRINK TUBING APPROXIMATELY WHERE SHOWN.
- APPLY PROTECTIVE COATING (ITEM 8) OVER MARKING.
- STAMP PIN 1 ON END OF CONNECTOR WHERE SHOWN, 17 PLACES.
- CONNECTOR J100-J116 WILL LATER CONNECT TO RECEIVER BLOCK, ITI PIN VGRCB-170/HR. WATING IFA CONNECTOR BLOCK IS ITI PIN VGFGB-170.

- MARK 407277-005 AND LATEST REVISION ON APPROPRIATE SIZE SHRINK TUBING APPROXIMATELY WHERE SHOWN.
- PLACE APPROPRIATE SIZE CLEAR SHRINK TUBING OVER MARKING.
- SPlice WIRE AS FOLLOWS:
 A) CUT AND SLIDE INSULATION TO EXPOSED CONDUCTOR AS SHOWN.
 B) SOLDER WIRE (ITEM 6) TO EXPOSED CONDUCTOR.
 C) COVER SPlice WITH APPROPRIATE SIZE SHRINK TUBING.
- CUT WIRE LENGTH TO 3.0±1.0

17 PLCS J100 THRU J116
 10 REGD REF

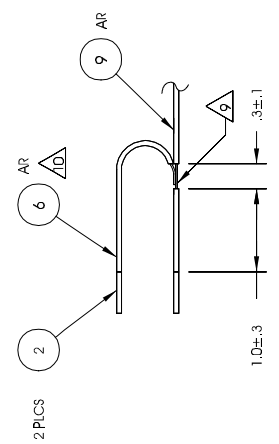

DETAIL A
 5 REGD 17 PLCS
 J100 THRU J116

ENGINEERING WIRE LIST

WIRE	FROM	TO	TYPE	PART #	WIRE LEN	REFERENCE
	BLK AAx RW 01 (J100)	Uxx-SLOT yy (J200)	CABLE	407277-005		SYSTEM WIRE LIST
	BLK AAx RW 02 (J101)	Uxx-SLOT yy (J200)	CABLE	407277-005		
	BLK AAx RW 03 (J102)	Uxx-SLOT yy (J200)	CABLE	407277-005		
	BLK AAx RW 04 (J103)	Uxx-SLOT yy (J200)	CABLE	407277-005		
	BLK AAx RW 05 (J104)	Uxx-SLOT yy (J200)	CABLE	407277-005		
	BLK AAx RW 06 (J105)	Uxx-SLOT yy (J200)	CABLE	407277-005		
	BLK AAx RW 07 (J106)	Uxx-SLOT yy (J200)	CABLE	407277-005		
	BLK AAx RW 08 (J107)	Uxx-SLOT yy (J200)	CABLE	407277-005		
	BLK AAx RW 09 (J108)	Uxx-SLOT yy (J201)	CABLE	407277-005		
	BLK AAx RW 10 (J109)	Uxx-SLOT yy (J201)	CABLE	407277-005		
	BLK AAx RW 11 (J110)	Uxx-SLOT yy (J201)	CABLE	407277-005		
	BLK AAx RW 12 (J111)	Uxx-SLOT yy (J201)	CABLE	407277-005		
	BLK AAx RW 13 (J112)	Uxx-SLOT yy (J201)	CABLE	407277-005		
	BLK AAx RW 14 (J113)	Uxx-SLOT yy (J201)	CABLE	407277-005		
	BLK AAx RW 15 (J114)	Uxx-SLOT yy (J201)	CABLE	407277-005		
	BLK AAx RW 16 (J115)	Uxx-SLOT yy (J201)	CABLE	407277-005		
	BLK AAx RW 17 (J116)	Uxx-SLOT yy (J200,J201)	CABLE	407277-005		
<p>This system wirelist serves as a template for incorporating this harness assembly into the overall system wirelist. It does not in any way affect the fabrication of this harness assembly.</p>						
<p>RACAL Instruments, Inc., 4 Goodyear St., Irvine, CA 92718</p>						
DOCUMENT TITLE			SIZE	CODE NO.	DOCUMENT NO.	REV
HARNESS ASSY, 1260-20, TTI			A	21793	407277-005	C
			DRN	SHEET 3 of 13		

DOC. NO. 407277-005

ENGINEERING WIRE LIST

WIRE	FROM	TO	TYPE	PART #	WIRE LEN	REFERENCE
1	J100-1 602199-001	SPLICE 1 (NEAR J100)	22AWG WHT	523999	3"	CHANNEL 00 IN HI
2	J100-2 602199-001	SPLICE 1 (NEAR J100)	22AWG WHT	523999	3"	CHANNEL 00 IN HI
3	SPLICE 1 (NEAR J100)	J200-A 602200	20AWG WHT	520999	40"	CHANNEL 00 IN HI
4	J100-3 602199-001	SPLICE 2 (NEAR J100)	22AWG WHT	523999	3"	CHANNEL 00 IN LO
5	J100-4 602199-001	SPLICE 2 (NEAR J100)	22AWG WHT	523999	3"	CHANNEL 00 IN LO
6	SPLICE 2 (NEAR J100)	J200-C 602200	20AWG WHT	520999	40"	CHANNEL 00 IN LO
7	J100-5 602199-001	SPLICE 3 (NEAR J100)	22AWG WHT	523999	3"	CHANNEL 00 OUT HI
8	J100-6 602199-001	SPLICE 3 (NEAR J100)	22AWG WHT	523999	3"	CHANNEL 00 OUT HI
9	SPLICE 3 (NEAR J100)	J200-D 602200	20AWG WHT	520999	40"	CHANNEL 00 OUT HI
10	J100-7 602199-001	SPLICE 4 (NEAR J100)	22AWG WHT	523999	3"	CHANNEL 00 OUT LO
11	J100-8 602199-001	SPLICE 4 (NEAR J100)	22AWG WHT	523999	3"	CHANNEL 00 OUT LO
12	SPLICE 4 (NEAR J100)	J200-K 602200	20AWG WHT	520999	40"	CHANNEL 00 OUT LO
13	J100-9 602199-001	SPLICE 5 (NEAR J100)	22AWG WHT	523999	3"	CHANNEL 01 IN HI
14	J100-10 602199-001	SPLICE 5 (NEAR J100)	22AWG WHT	523999	3"	CHANNEL 01 IN HI
15	SPLICE 5 (NEAR J100)	J200-E 602200	20AWG WHT	520999	40"	CHANNEL 01 IN HI
16	J101-1 602199-001	SPLICE 6 (NEAR J101)	22AWG WHT	523999	3"	CHANNEL 01 IN LO
17	J101-2 602199-001	SPLICE 6 (NEAR J101)	22AWG WHT	523999	3"	CHANNEL 01 IN LO
18	SPLICE 6 (NEAR J101)	J200-J 602200	20AWG WHT	520999	40"	CHANNEL 01 IN LO
19	J101-3 602199-001	SPLICE 7 (NEAR J101)	22AWG WHT	523999	3"	CHANNEL 01 OUT HI
20	J101-4 602199-001	SPLICE 7 (NEAR J101)	22AWG WHT	523999	3"	CHANNEL 01 OUT HI
21	SPLICE 7 (NEAR J101)	J200-H 602200	20AWG WHT	520999	40"	CHANNEL 01 OUT HI
22	J101-5 602199-001	SPLICE 8 (NEAR J101)	22AWG WHT	523999	3"	CHANNEL 01 OUT LO
23	J101-6 602199-001	SPLICE 8 (NEAR J101)	22AWG WHT	523999	3"	CHANNEL 01 OUT LO
24	SPLICE 8 (NEAR J101)	J200-L 602200	20AWG WHT	520999	40"	CHANNEL 01 OUT LO
25	J101-7 602199-001	SPLICE 9 (NEAR J101)	22AWG WHT	523999	3"	CHANNEL 02 IN HI

DOC. NO. 407277-005

RACAL Instruments, Inc., 4 Goodyear St., Irvine, CA 92718

DOCUMENT TITLE		SIZE	CODE NO.	DOCUMENT NO.	REV
HARNESS ASSY, 1260-20, TTI		A	21793	407277-005	G
		DRN			

SHEET 4 of 13

ENGINEERING WIRE LIST

WIRE	FROM	TO	TYPE	PART #	WIRE LEN	REFERENCE
26	J101-8 602199-001	SPLICE 9 (NEAR J101)	22AWG WHT	523999	3"	CHANNEL 02 IN HI
27	SPLICE 9 (NEAR J101)	J200-B 602200	20AWG WHT	520999	40"	CHANNEL 02 IN HI
28	J101-9 602199-001	SPLICE 10 (NEAR J101)	22AWG WHT	523999	3"	CHANNEL 02 IN LO
29	J101-10 602199-001	SPLICE 10 (NEAR J101)	22AWG WHT	523999	3"	CHANNEL 02 IN LO
30	SPLICE 10 (NEAR J101)	J200-M 602200	20AWG WHT	520999	40"	CHANNEL 02 IN LO
31	J102-1 602199-001	SPLICE 11 (NEAR J102)	22AWG WHT	523999	3"	CHANNEL 02 OUT HI
32	J102-2 602199-001	SPLICE 11 (NEAR J102)	22AWG WHT	523999	3"	CHANNEL 02 OUT HI
33	SPLICE 11 (NEAR J102)	J200-F 602200	20AWG WHT	520999	40"	CHANNEL 02 OUT HI
34	J102-3 602199-001	SPLICE 12 (NEAR J102)	22AWG WHT	523999	3"	CHANNEL 02 OUT LO
35	J102-4 602199-001	SPLICE 12 (NEAR J102)	22AWG WHT	523999	3"	CHANNEL 02 OUT LO
36	SPLICE 12 (NEAR J102)	J200-N 602200	20AWG WHT	520999	40"	CHANNEL 02 OUT LO
37	J102-5 602199-001	SPLICE 13 (NEAR J102)	22AWG WHT	523999	3"	CHANNEL 03 IN HI
38	J102-6 602199-001	SPLICE 13 (NEAR J102)	22AWG WHT	523999	3"	CHANNEL 03 IN HI
39	SPLICE 13 (NEAR J102)	J200-P 602200	20AWG WHT	520999	40"	CHANNEL 03 IN HI
40	J102-7 602199-001	SPLICE 14 (NEAR J102)	22AWG WHT	523999	3"	CHANNEL 03 IN LO
41	J102-8 602199-001	SPLICE 14 (NEAR J102)	22AWG WHT	523999	3"	CHANNEL 03 IN LO
42	SPLICE 14 (NEAR J102)	J200-S 602200	20AWG WHT	520999	40"	CHANNEL 03 IN LO
43	J102-9 602199-001	SPLICE 15 (NEAR J102)	22AWG WHT	523999	3"	CHANNEL 03 OUT HI
44	J102-10 602199-001	SPLICE 15 (NEAR J102)	22AWG WHT	523999	3"	CHANNEL 03 OUT HI
45	SPLICE 15 (NEAR J102)	J200-T 602200	20AWG WHT	520999	40"	CHANNEL 03 OUT HI
46	J103-1 602199-001	SPLICE 16 (NEAR J103)	22AWG WHT	523999	3"	CHANNEL 03 OUT LO
47	J103-2 602199-001	SPLICE 16 (NEAR J103)	22AWG WHT	523999	3"	CHANNEL 03 OUT LO
48	SPLICE 16 (NEAR J103)	J200-Y 602200	20AWG WHT	520999	40"	CHANNEL 03 OUT LO
49	J103-3 602199-001	SPLICE 17 (NEAR J103)	22AWG WHT	523999	3"	CHANNEL 04 IN HI
50	J103-4 602199-001	SPLICE 17 (NEAR J103)	22AWG WHT	523999	3"	CHANNEL 04 IN HI

DOC. NO. 407277-005

RACAL Instruments, Inc., 4 Goodyear St., Irvine, CA 92718					
DOCUMENT TITLE		SIZE	CODE NO.	DOCUMENT NO.	REV
HARNESS ASSY, 1260-20, TTI		A	21793	407277-005	C
DRN				SHEET 5 of 13	

ENGINEERING WIRE LIST

WIRE	FROM	TO	TYPE	PART #	WIRE LEN	REFERENCE
51	SPLICE 17 (NEAR J103)	J200-U 602200	20AWG WHT	520999	40"	CHANNEL 04 IN HI
52	J103-5 602199-001	SPLICE 18 (NEAR J103)	22AWG WHT	523999	3"	CHANNEL 04 IN LO
53	J103-6 602199-001	SPLICE 18 (NEAR J103)	22AWG WHT	523999	3"	CHANNEL 04 IN LO
54	SPLICE 18 (NEAR J103)	J200-X 602200	20AWG WHT	520999	40"	CHANNEL 04 IN LO
55	J103-7 602199-001	SPLICE 19 (NEAR J103)	22AWG WHT	523999	3"	CHANNEL 04 OUT HI
56	J103-8 602199-001	SPLICE 19 (NEAR J103)	22AWG WHT	523999	3"	CHANNEL 04 OUT HI
57	SPLICE 19 (NEAR J103)	J200-W 602200	20AWG WHT	520999	40"	CHANNEL 04 OUT HI
58	J103-9 602199-001	SPLICE 20 (NEAR J103)	22AWG WHT	523999	3"	CHANNEL 04 OUT LO
59	J103-10 602199-001	SPLICE 20 (NEAR J103)	22AWG WHT	523999	3"	CHANNEL 04 OUT LO
60	SPLICE 20 (NEAR J103)	J200-e 602200	20AWG WHT	520999	40"	CHANNEL 04 OUT LO
61	J104-1 602199-001	SPLICE 21 (NEAR J104)	22AWG WHT	523999	3"	CHANNEL 05 IN HI
62	J104-2 602199-001	SPLICE 21 (NEAR J104)	22AWG WHT	523999	3"	CHANNEL 05 IN HI
63	SPLICE 21 (NEAR J104)	J200-V 602200	20AWG WHT	520999	40"	CHANNEL 05 IN HI
64	J104-3 602199-001	SPLICE 22 (NEAR J104)	22AWG WHT	523999	3"	CHANNEL 05 IN LO
65	J104-4 602199-001	SPLICE 22 (NEAR J104)	22AWG WHT	523999	3"	CHANNEL 05 IN LO
66	SPLICE 22 (NEAR J104)	J200-R 602200	20AWG WHT	520999	40"	CHANNEL 05 IN LO
67	J104-5 602199-001	SPLICE 23 (NEAR J104)	22AWG WHT	523999	3"	CHANNEL 05 OUT HI
68	J104-6 602199-001	SPLICE 23 (NEAR J104)	22AWG WHT	523999	3"	CHANNEL 05 OUT HI
69	SPLICE 23 (NEAR J104)	J200-a 602200	20AWG WHT	520999	40"	CHANNEL 05 OUT HI
70	J104-7 602199-001	SPLICE 24 (NEAR J104)	22AWG WHT	523999	3"	CHANNEL 05 OUT LO
71	J104-8 602199-001	SPLICE 24 (NEAR J104)	22AWG WHT	523999	3"	CHANNEL 05 OUT LO
72	SPLICE 24 (NEAR J104)	J200-Z 602200	20AWG WHT	520999	40"	CHANNEL 05 OUT LO
73	J104-9 602199-001	SPLICE 25 (NEAR J104)	22AWG WHT	523999	3"	CHANNEL 06 IN HI
74	J104-10 602199-001	SPLICE 25 (NEAR J104)	22AWG WHT	523999	3"	CHANNEL 06 IN HI
75	SPLICE 25 (NEAR J104)	J200-b 602200	20AWG WHT	520999	40"	CHANNEL 06 IN HI
RACAL Instruments, Inc., 4 Goodyear St., Irvine, CA 92718						
DOCUMENT TITLE			SIZE	CODE NO.	DOCUMENT NO.	REV
HARNESS ASSY, 1260-20, TTI			A	21793	407277-005	C
			DRN	SHEET 6 of 13		

DOC NO. 407277-005

ENGINEERING WIRE LIST

WIRE	FROM	TO	TYPE	PART #	WIRE LEN	REFERENCE
76	J105-1 602199-001	SPLICE 26 (NEAR J105)	22AWG WHT	523999	3"	CHANNEL 06 IN LO
77	J105-2 602199-001	SPLICE 26 (NEAR J105)	22AWG WHT	523999	3"	CHANNEL 06 IN LO
78	SPLICE 26 (NEAR J105)	J200-c 602200	20AWG WHT	520999	40"	CHANNEL 06 IN LO
79	J105-3 602199-001	SPLICE 27 (NEAR J105)	22AWG WHT	523999	3"	CHANNEL 06 OUT HI
80	J105-4 602199-001	SPLICE 27 (NEAR J105)	22AWG WHT	523999	3"	CHANNEL 06 OUT HI
81	SPLICE 27 (NEAR J105)	J200-j 602200	20AWG WHT	520999	40"	CHANNEL 06 OUT HI
82	J105-5 602199-001	SPLICE 28 (NEAR J105)	22AWG WHT	523999	3"	CHANNEL 06 OUT LO
83	J105-6 602199-001	SPLICE 28 (NEAR J105)	22AWG WHT	523999	3"	CHANNEL 06 OUT LO
84	SPLICE 28 (NEAR J105)	J200-d 602200	20AWG WHT	520999	40"	CHANNEL 06 OUT LO
85	J105-7 602199-001	SPLICE 29 (NEAR J105)	22AWG WHT	523999	3"	CHANNEL 07 IN HI
86	J105-8 602199-001	SPLICE 29 (NEAR J105)	22AWG WHT	523999	3"	CHANNEL 07 IN HI
87	SPLICE 29 (NEAR J105)	J200-m 602200	20AWG WHT	520999	40"	CHANNEL 07 IN HI
88	J105-9 602199-001	SPLICE 30 (NEAR J105)	22AWG WHT	523999	3"	CHANNEL 07 IN LO
89	J105-10 602199-001	SPLICE 30 (NEAR J105)	22AWG WHT	523999	3"	CHANNEL 07 IN LO
90	SPLICE 30 (NEAR J105)	J200-n 602200	20AWG WHT	520999	40"	CHANNEL 07 IN LO
91	J106-1 602199-001	SPLICE 31 (NEAR J106)	22AWG WHT	523999	3"	CHANNEL 07 OUT HI
92	J106-2 602199-001	SPLICE 31 (NEAR J106)	22AWG WHT	523999	3"	CHANNEL 07 OUT HI
93	SPLICE 31 (NEAR J106)	J200-v 602200	20AWG WHT	520999	40"	CHANNEL 07 OUT HI
94	J106-3 602199-001	SPLICE 32 (NEAR J106)	22AWG WHT	523999	3"	CHANNEL 07 OUT LO
95	J106-4 602199-001	SPLICE 32 (NEAR J106)	22AWG WHT	523999	3"	CHANNEL 07 OUT LO
96	SPLICE 32 (NEAR J106)	J200-h 602200	20AWG WHT	520999	40"	CHANNEL 07 OUT LO
97	J106-5 602199-001	SPLICE 33 (NEAR J106)	22AWG WHT	523999	3"	CHANNEL 08 IN HI
98	J106-6 602199-001	SPLICE 33 (NEAR J106)	22AWG WHT	523999	3"	CHANNEL 08 IN HI
99	SPLICE 33 (NEAR J106)	J200-p 602200	20AWG WHT	520999	40"	CHANNEL 08 IN HI
100	J106-7 602199-001	SPLICE 34 (NEAR J106)	22AWG WHT	523999	3"	CHANNEL 08 IN LO

DOC. NO. 407277-005

RACAL Instruments, Inc., 4 Goodyear St., Irvine, CA 92718

DOCUMENT TITLE	SIZE	CODE NO.	DOCUMENT NO.	REV
HARNESS ASSY, 1260-20, TTI	A	21793	407277-005	C
	DRN		SHEET 7 of 13	

ENGINEERING WIRE LIST

WIRE	FROM	TO	TYPE	PART #	WIRE LEN	REFERENCE
101	J106-8 602199-001	SPLICE 34 (NEAR J106)	22AWG WHT	523999	3"	CHANNEL 08 IN LO
102	SPLICE 34 (NEAR J106)	J200-f 602200	20AWG WHT	520999	40"	CHANNEL 08 IN LO
103	J106-9 602199-001	SPLICE 35 (NEAR J106)	22AWG WHT	523999	3"	CHANNEL 08 OUT HI
104	J106-10 602199-001	SPLICE 35 (NEAR J106)	22AWG WHT	523999	3"	CHANNEL 08 OUT HI
105	SPLICE 35 (NEAR J106)	J200-r 602200	20AWG WHT	520999	40"	CHANNEL 08 OUT HI
106	J107-1 602199-001	SPLICE 36 (NEAR J107)	22AWG WHT	523999	3"	CHANNEL 08 OUT LO
107	J107-2 602199-001	SPLICE 36 (NEAR J107)	22AWG WHT	523999	3"	CHANNEL 08 OUT LO
108	SPLICE 36 (NEAR J107)	J200-k 602200	20AWG WHT	520999	40"	CHANNEL 08 OUT LO
109	J107-3 602199-001	SPLICE 37 (NEAR J107)	22AWG WHT	523999	3"	CHANNEL 09 IN HI
110	J107-4 602199-001	SPLICE 37 (NEAR J107)	22AWG WHT	523999	3"	CHANNEL 09 IN HI
111	SPLICE 37 (NEAR J107)	J200-x 602200	20AWG WHT	520999	40"	CHANNEL 09 IN HI
112	J107-5 602199-001	SPLICE 38 (NEAR J107)	22AWG WHT	523999	3"	CHANNEL 09 IN LO
113	J107-6 602199-001	SPLICE 38 (NEAR J107)	22AWG WHT	523999	3"	CHANNEL 09 IN LO
114	SPLICE 38 (NEAR J107)	J200-t 602200	20AWG WHT	520999	40"	CHANNEL 09 IN LO
115	J107-7 602199-001	SPLICE 39 (NEAR J107)	22AWG WHT	523999	3"	CHANNEL 09 OUT HI
116	J107-8 602199-001	SPLICE 39 (NEAR J107)	22AWG WHT	523999	3"	CHANNEL 09 OUT HI
117	SPLICE 39 (NEAR J107)	J200-s 602200	20AWG WHT	520999	40"	CHANNEL 09 OUT HI
118	J107-9 602199-001	SPLICE 40 (NEAR J107)	22AWG WHT	523999	3"	CHANNEL 09 OUT LO
119	J107-10 602199-001	SPLICE 40 (NEAR J107)	22AWG WHT	523999	3"	CHANNEL 09 OUT LO
120	SPLICE 40 (NEAR J107)	J200-u 602200	20AWG WHT	520999	40"	CHANNEL 09 OUT LO
121	J108-1 602199-001	SPLICE 41 (NEAR J108)	22AWG WHT	523999	3"	CHANNEL 10 IN HI
122	J108-2 602199-001	SPLICE 41 (NEAR J108)	22AWG WHT	523999	3"	CHANNEL 10 IN HI
123	SPLICE 41 (NEAR J108)	J201-A 602200	20AWG WHT	520999	40"	CHANNEL 10 IN HI
124	J108-3 602199-001	SPLICE 42 (NEAR J108)	22AWG WHT	523999	3"	CHANNEL 10 IN LO
125	J108-4 602199-001	SPLICE 42 (NEAR J108)	22AWG WHT	523999	3"	CHANNEL 10 IN LO

RACAL Instruments, Inc., 4 Goodyear St., Irvine, CA 92718

DOCUMENT TITLE		SIZE	CODE NO.	DOCUMENT NO.	REV
HARNESS ASSY, 1260-20, TTI		A	21793	407277-005	C
				SHEET 8 of 13	

DOC. NO. 407277-005

ENGINEERING WIRE LIST

WIRE	FROM	TO	TYPE	PART #	WIRE LEN	REFERENCE
126	SPLICE 42 (NEAR J108)	J201-C 602200	20AWG WHT	520999	40"	CHANNEL 10 IN LO
127	J108-5 602199-001	SPLICE 43 (NEAR J108)	22AWG WHT	523999	3"	CHANNEL 10 OUT HI
128	J108-6 602199-001	SPLICE 43 (NEAR J108)	22AWG WHT	523999	3"	CHANNEL 10 OUT HI
129	SPLICE 43 (NEAR J108)	J201-D 602200	20AWG WHT	520999	40"	CHANNEL 10 OUT HI
130	J108-7 602199-001	SPLICE 44 (NEAR J108)	22AWG WHT	523999	3"	CHANNEL 10 OUT LO
131	J108-8 602199-001	SPLICE 44 (NEAR J108)	22AWG WHT	523999	3"	CHANNEL 10 OUT LO
132	SPLICE 44 (NEAR J108)	J201-K 602200	20AWG WHT	520999	40"	CHANNEL 10 OUT LO
133	J108-9 602199-001	SPLICE 45 (NEAR J108)	22AWG WHT	523999	3"	CHANNEL 11 IN HI
134	J108-10 602199-001	SPLICE 45 (NEAR J108)	22AWG WHT	523999	3"	CHANNEL 11 IN HI
135	SPLICE 45 (NEAR J108)	J201-E 602200	20AWG WHT	520999	40"	CHANNEL 11 IN HI
136	J109-1 602199-001	SPLICE 46 (NEAR J109)	22AWG WHT	523999	3"	CHANNEL 11 IN LO
137	J109-2 602199-001	SPLICE 46 (NEAR J109)	22AWG WHT	523999	3"	CHANNEL 11 IN LO
138	SPLICE 46 (NEAR J109)	J201-J 602200	20AWG WHT	520999	40"	CHANNEL 11 IN LO
139	J109-3 602199-001	SPLICE 47 (NEAR J109)	22AWG WHT	523999	3"	CHANNEL 11 OUT HI
140	J109-4 602199-001	SPLICE 47 (NEAR J109)	22AWG WHT	523999	3"	CHANNEL 11 OUT HI
141	SPLICE 47 (NEAR J109)	J201-H 602200	20AWG WHT	520999	40"	CHANNEL 11 OUT HI
142	J109-5 602199-001	SPLICE 48 (NEAR J109)	22AWG WHT	523999	3"	CHANNEL 11 OUT LO
143	J109-6 602199-001	SPLICE 48 (NEAR J109)	22AWG WHT	523999	3"	CHANNEL 11 OUT LO
144	SPLICE 48 (NEAR J109)	J201-L 602200	20AWG WHT	520999	40"	CHANNEL 11 OUT LO
145	J109-7 602199-001	SPLICE 49 (NEAR J109)	22AWG WHT	523999	3"	CHANNEL 12 IN HI
146	J109-8 602199-001	SPLICE 49 (NEAR J109)	22AWG WHT	523999	3"	CHANNEL 12 IN HI
147	SPLICE 49 (NEAR J109)	J201-B 602200	20AWG WHT	520999	40"	CHANNEL 12 IN HI
148	J109-9 602199-001	SPLICE 50 (NEAR J109)	22AWG WHT	523999	3"	CHANNEL 12 IN LO
149	J109-10 602199-001	SPLICE 50 (NEAR J109)	22AWG WHT	523999	3"	CHANNEL 12 IN LO
150	SPLICE 50 (NEAR J109)	J201-M 602200	20AWG WHT	520999	40"	CHANNEL 12 IN LO

DOC. NO. 407277-005

RACAL Instruments, Inc., 4 Goodyear St., Irvine, CA 92718			
DOCUMENT TITLE	SIZE	CODE NO.	DOCUMENT NO.
HARNESS ASSY, 1260-20, TTI	A	21793	407277-005
	DRN		SHEET 9 of 13
			REV C

ENGINEERING WIRE LIST

WIRE	FROM	TO	TYPE	PART #	WIRE LEN	REFERENCE
151	J110-1 602199-001	SPLICE 51 (NEAR J110)	22AWG WHT	523999	3"	CHANNEL 12 OUT HI
152	J110-2 602199-001	SPLICE 51 (NEAR J110)	22AWG WHT	523999	3"	CHANNEL 12 OUT HI
153	SPLICE 51 (NEAR J110)	J201-F 602200	20AWG WHT	520999	40"	CHANNEL 12 OUT HI
154	J110-3 602199-001	SPLICE 52 (NEAR J110)	22AWG WHT	523999	3"	CHANNEL 12 OUT LO
155	J110-4 602199-001	SPLICE 52 (NEAR J110)	22AWG WHT	523999	3"	CHANNEL 12 OUT LO
156	SPLICE 52 (NEAR J110)	J201-N 602200	20AWG WHT	520999	40"	CHANNEL 12 OUT LO
157	J110-5 602199-001	SPLICE 53 (NEAR J110)	22AWG WHT	523999	3"	CHANNEL 13 IN HI
158	J110-6 602199-001	SPLICE 53 (NEAR J110)	22AWG WHT	523999	3"	CHANNEL 13 IN HI
159	SPLICE 53 (NEAR J110)	J201-P 602200	20AWG WHT	520999	40"	CHANNEL 13 IN HI
160	J110-7 602199-001	SPLICE 54 (NEAR J110)	22AWG WHT	523999	3"	CHANNEL 13 IN LO
161	J110-8 602199-001	SPLICE 54 (NEAR J110)	22AWG WHT	523999	3"	CHANNEL 13 IN LO
162	SPLICE 54 (NEAR J110)	J201-S 602200	20AWG WHT	520999	40"	CHANNEL 13 IN LO
163	J110-9 602199-001	SPLICE 55 (NEAR J110)	22AWG WHT	523999	3"	CHANNEL 13 OUT HI
164	J110-10 602199-001	SPLICE 55 (NEAR J110)	22AWG WHT	523999	3"	CHANNEL 13 OUT HI
165	SPLICE 55 (NEAR J110)	J201-T 602200	20AWG WHT	520999	40"	CHANNEL 13 OUT HI
166	J111-1 602199-001	SPLICE 56 (NEAR J111)	22AWG WHT	523999	3"	CHANNEL 13 OUT LO
167	J111-2 602199-001	SPLICE 56 (NEAR J111)	22AWG WH	523999	3"	CHANNEL 13 OUT LO
168	SPLICE 56 (NEAR J111)	J201-Y 602200	20AWG WHT	520999	40"	CHANNEL 13 OUT LO
169	J111-3 602199-001	SPLICE 57 (NEAR J111)	22AWG WHT	523999	3"	CHANNEL 14 IN HI
170	J111-4 602199-001	SPLICE 57 (NEAR J111)	22AWG WHT	523999	3"	CHANNEL 14 IN HI
171	SPLICE 57 (NEAR J111)	J201-U 602200	20AWG WHT	520999	40"	CHANNEL 14 IN HI
172	J111-5 602199-001	SPLICE 58 (NEAR J111)	22AWG WHT	523999	3"	CHANNEL 14 IN LO
173	J111-6 602199-001	SPLICE 58 (NEAR J111)	22AWG WHT	523999	3"	CHANNEL 14 IN LO
174	SPLICE 58 (NEAR J111)	J201-X 602200	20AWG WHT	520999	40"	CHANNEL 14 IN LO
175	J111-7 602199-001	SPLICE 59 (NEAR J111)	22AWG WHT	523999	3"	CHANNEL 14 OUT HI

RACAL Instruments, Inc., 4 Goodyear St., Irvine, CA 92718

DOCUMENT TITLE		SIZE	CODE NO.	DOCUMENT NO.	REV
HARNESS ASSY, 1260-20, TTI		A	21793	407277-005	C
		DRN			SHEET 10 of 13

DOC. NO. 407277-005

ENGINEERING WIRE LIST

WIRE	FROM	TO	TYPE	PART #	WIRE LEN	REFERENCE
176	J111-8 602199-001	SPLICE 59 (NEAR J111)	22AWG WHT	523999	3"	CHANNEL 14 OUT HI
177	SPLICE 59 (NEAR J111)	J201-e 602200	20AWG WHT	520999	40"	CHANNEL 14 OUT HI
178	J111-9 602199-001	SPLICE 60 (NEAR J111)	22AWG WHT	523999	3"	CHANNEL 14 OUT LO
179	J111-10 602199-001	SPLICE 60 (NEAR J111)	22AWG WHT	523999	3"	CHANNEL 14 OUT LO
180	SPLICE 60 (NEAR J111)	J201-W 602200	20AWG WHT	520999	40"	CHANNEL 14 OUT LO
181	J112-1 602199-001	SPLICE 61 (NEAR J112)	22AWG WHT	523999	3"	CHANNEL 15 IN HI
182	J112-2 602199-001	SPLICE 61 (NEAR J112)	22AWG WHT	523999	3"	CHANNEL 15 IN HI
183	SPLICE 61 (NEAR J112)	J201-V 602200	20AWG WHT	520999	40"	CHANNEL 15 IN HI
184	J112-3 602199-001	SPLICE 62 (NEAR J112)	22AWG WHT	523999	3"	CHANNEL 15 IN LO
185	J112-4 602199-001	SPLICE 62 (NEAR J112)	22AWG WHT	523999	3"	CHANNEL 15 IN LO
186	SPLICE 62 (NEAR J112)	J201-R 602200	20AWG WHT	520999	40"	CHANNEL 15 IN LO
187	J112-5 602199-001	SPLICE 63 (NEAR J112)	22AWG WHT	523999	3"	CHANNEL 15 OUT HI
188	J112-6 602199-001	SPLICE 63 (NEAR J112)	22AWG WHT	523999	3"	CHANNEL 15 OUT HI
189	SPLICE 63 (NEAR J112)	J201-a 602200	20AWG WHT	520999	40"	CHANNEL 15 OUT HI
190	J112-7 602199-001	SPLICE 64 (NEAR J112)	22AWG WHT	523999	3"	CHANNEL 15 OUT LO
191	J112-8 602199-001	SPLICE 64 (NEAR J112)	22AWG WHT	523999	3"	CHANNEL 15 OUT LO
192	SPLICE 64 (NEAR J112)	J201-Z 602200	20AWG WHT	520999	40"	CHANNEL 15 OUT LO
193	J112-9 602199-001	SPLICE 65 (NEAR J112)	22AWG WHT	523999	3"	CHANNEL 16 IN HI
194	J112-10 602199-001	SPLICE 65 (NEAR J112)	22AWG WHT	523999	3"	CHANNEL 16 IN HI
195	SPLICE 65 (NEAR J112)	J201-b 602200	20AWG WHT	520999	40"	CHANNEL 16 IN HI
196	J113-1 602199-001	SPLICE 66 (NEAR J113)	22AWG WHT	523999	3"	CHANNEL 16 IN LO
197	J113-2 602199-001	SPLICE 66 (NEAR J113)	22AWG WHT	523999	3"	CHANNEL 16 IN LO
198	SPLICE 66 (NEAR J113)	J201-c 602200	20AWG WHT	520999	40"	CHANNEL 16 IN LO
299	J113-3 602199-001	SPLICE 67 (NEAR J113)	22AWG WHT	523999	3"	CHANNEL 16 OUT HI
200	J113-4 602199-001	SPLICE 67 (NEAR J113)	22AWG WHT	523999	3"	CHANNEL 16 OUT HI

DOC. NO. 407277-005

RACAL Instruments, Inc., 4 Goodyear St., Irvine, CA 92718			
DOCUMENT TITLE	SIZE	CODE NO.	DOCUMENT NO.
HARNESS ASSY, 1260-20, TTI	A	21793	407277-005
	DRN		SHEET 11 of 13
			REV C

ENGINEERING WIRE LIST

WIRE	FROM	TO	TYPE	PART #	WIRE LEN	REFERENCE
201	SPLICE 67 (NEAR J113)	J201-j 602200	20AWG WHT	520999	40"	CHANNEL 16 OUT HI
202	J113-5 602199-001	SPLICE 68 (NEAR J113)	22AWG WHT	523999	3"	CHANNEL 16 OUT LO
203	J113-6 602199-001	SPLICE 68 (NEAR J113)	22AWG WHT	523999	3"	CHANNEL 16 OUT LO
204	SPLICE 68 (NEAR J113)	J201-d 602200	20AWG WHT	520999	40"	CHANNEL 16 OUT LO
205	J113-7 602199-001	SPLICE 69 (NEAR J113)	22AWG WHT	523999	3"	CHANNEL 17 IN HI
206	J113-8 602199-001	SPLICE 69 (NEAR J113)	22AWG WHT	523999	3"	CHANNEL 17 IN HI
207	SPLICE 69 (NEAR J113)	J201-m 602200	20AWG WHT	520999	40"	CHANNEL 17 IN HI
208	J113-9 602199-001	SPLICE 70 (NEAR J113)	22AWG WHT	523999	3"	CHANNEL 17 IN LO
209	J113-10 602199-001	SPLICE 70 (NEAR J113)	22AWG WHT	523999	3"	CHANNEL 17 IN LO
210	SPLICE 70 (NEAR J113)	J201-n 602200	20AWG WHT	520999	40"	CHANNEL 17 IN LO
211	J114-1 602199-001	SPLICE 71 (NEAR J114)	22AWG WHT	523999	3"	CHANNEL 17 OUT HI
212	J114-2 602199-001	SPLICE 71 (NEAR J114)	22AWG WHT	523999	3"	CHANNEL 17 OUT HI
213	SPLICE 71 (NEAR J114)	J201-v 602200	20AWG WHT	520999	40"	CHANNEL 17 OUT HI
214	J114-3 602199-001	SPLICE 72 (NEAR J114)	22AWG WHT	523999	3"	CHANNEL 17 OUT LO
215	J114-4 602199-001	SPLICE 72 (NEAR J114)	22AWG WHT	523999	3"	CHANNEL 17 OUT LO
216	SPLICE 72 (NEAR J114)	J201-h 602200	20AWG WHT	520999	40"	CHANNEL 17 OUT LO
217	J114-5 602199-001	SPLICE 73 (NEAR J114)	22AWG WHT	523999	3"	CHANNEL 18 IN HI
218	J114-6 602199-001	SPLICE 73 (NEAR J114)	22AWG WHT	523999	3"	CHANNEL 18 IN HI
219	SPLICE 73 (NEAR J114)	J201-p 602200	20AWG WHT	520999	40"	CHANNEL 18 IN HI
220	J114-7 602199-001	SPLICE 74 (NEAR J114)	22AWG WHT	523999	3"	CHANNEL 18 IN LO
221	J114-8 602199-001	SPLICE 74 (NEAR J114)	22AWG WHT	523999	3"	CHANNEL 18 IN LO
222	SPLICE 74 (NEAR J114)	J201-f 602200	20AWG WHT	520999	40"	CHANNEL 18 IN LO
223	J114-9 602199-001	SPLICE 75 (NEAR J114)	22AWG WHT	523999	3"	CHANNEL 18 OUT HI
224	J114-10 602199-001	SPLICE 75 (NEAR J114)	22AWG WHT	523999	3"	CHANNEL 18 OUT HI
225	SPLICE 75 (NEAR J114)	J201-r 602200	20AWG WHT	520999	40"	CHANNEL 18 OUT HI

DOC. NO. 407277-005

RACAL Instruments, Inc., 4 Goodyear St., Irvine, CA 92718						
DOCUMENT TITLE			SIZE	CODE NO.	DOCUMENT NO.	REV
HARNESS ASSY, 1260-20, TTI			A	21793	407277-005	C
DRN					SHEET 12 of 13	

ENGINEERING WIRE LIST

WIRE	FROM	TO	TYPE	PART #	WIRE LEN	REFERENCE
226	J115-1 602199-001	SPLICE 76 (NEAR J115)	22AWG WHT	523999	3"	CHANNEL 18 OUT LO
227	J115-2 602199-001	SPLICE 76 (NEAR J115)	22AWG WHT	523999	3"	CHANNEL 18 OUT LO
228	SPLICE 76 (NEAR J115)	J201-k 602200	20AWG WHT	520999	40"	CHANNEL 18 OUT LO
229	J115-3 602199-001	SPLICE 77 (NEAR J115)	22AWG WHT	523999	3"	CHANNEL 19 IN HI
230	J115-4 602199-001	SPLICE 77 (NEAR J115)	22AWG WHT	523999	3"	CHANNEL 19 IN HI
231	SPLICE 77 (NEAR J115)	J201-x 602200	20AWG WHT	520999	40"	CHANNEL 19 IN HI
232	J115-5 602199-001	SPLICE 78 (NEAR J115)	22AWG WHT	523999	3"	CHANNEL 19 IN LO
233	J115-6 602199-001	SPLICE 78 (NEAR J115)	22AWG WHT	523999	3"	CHANNEL 19 IN LO
234	SPLICE 78 (NEAR J115)	J201-t 602200	20AWG WHT	520999	40"	CHANNEL 19 IN LO
235	J115-7 602199-001	SPLICE 79 (NEAR J115)	22AWG WHT	523999	3"	CHANNEL 19 OUT HI
236	J115-8 602199-001	SPLICE 79 (NEAR J115)	22AWG WHT	523999	3"	CHANNEL 19 OUT HI
237	SPLICE 79 (NEAR J115)	J201-s 602200	20AWG WHT	520999	40"	CHANNEL 19 OUT HI
238	J115-9 602199-001	SPLICE 80 (NEAR J115)	22AWG WHT	523999	3"	CHANNEL 19 OUT LO
239	J115-10 602199-001	SPLICE 80 (NEAR J115)	22AWG WHT	523999	3"	CHANNEL 19 OUT LO
240	SPLICE 80 (NEAR J115)	J201-u 602200	20AWG WHT	520999	40"	CHANNEL 19 OUT LO
241	J116-1 602199-001	J200-w 602200	20 AWG WHT	520999	40"	CHASSIS GND
242	J116-2 602199-001	J201-w 602200	20AWG WHT	520999	40"	CHASSIS GND
243	J116-3 602199-001	NO CONNECT				
244	J116-4 602199-001	NO CONNECT				
245	J116-5 602199-001	NO CONNECT				
246	J116-6 602199-001	NO CONNECT				
247	J116-7 602199-001	NO CONNECT				
248	J116-8 602199-001	NO CONNECT				
249	J116-9 602199-001	NO CONNECT				
250	J116-10 602199-001	NO CONNECT				

DOC NO. 407277-005

RACAL Instruments, Inc., 4 Goodyear St., Irvine, CA 92718				
DOCUMENT TITLE	SIZE	CODE NO.	DOCUMENT NO.	REV
HARNESS ASSY, 1260-20, TTI	A	21793	407277-005	.C
	DRN		SHEET 13 of 13	

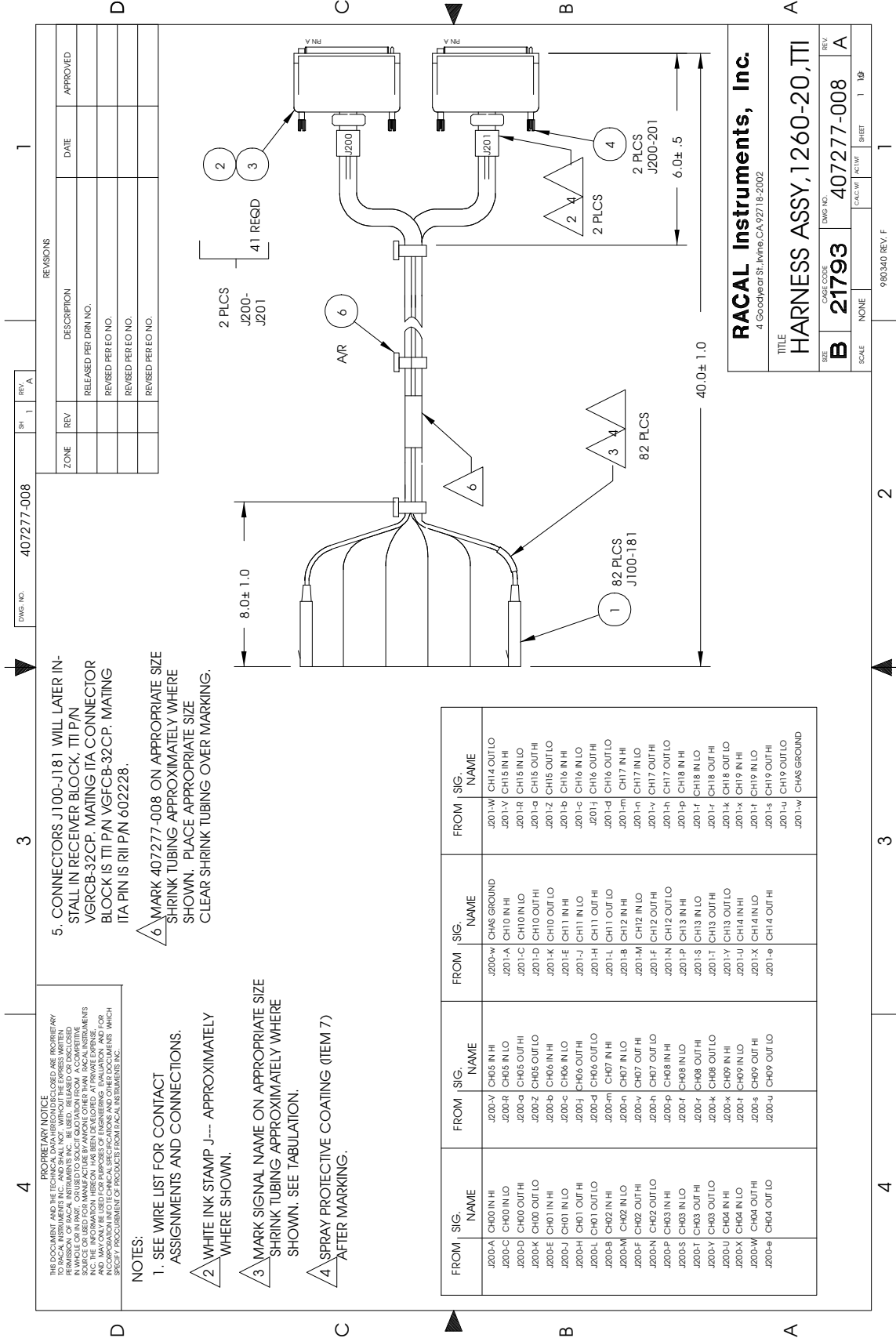

ZONE	REV	DESCRIPTION	DATE	APPROVED
		RELEASED PER DRN NO.		
		REVISED PER ECO NO.		
		REVISED PER ECO NO.		

REV	DATE	DESCRIPTION

REV	DATE	DESCRIPTION

REV	DATE	DESCRIPTION

RACAL Instruments, Inc.	
4 Goodyear St., Irvine, CA 92718-2002	
TITLE	HARNASS ASSY, 1260-20, ITI
SIZE	
CAGE CODE	DWG NO. 407277-008
REV	REV
B	21793
SCALE	NONE
CHECKED	ACT/WT
SHEET	1
TBP	

FROM SIG. NAME	FROM SIG. NAME	FROM SIG. NAME	FROM SIG. NAME	FROM SIG. NAME
J200-A CH00 IN HI	J200-V CH05 IN HI	J200-W CHAS GROUND	J201-W CH14 OUT LO	J201-W CHAS GROUND
J200-C CH00 IN LO	J200-R CH05 IN LO	J201-A CH10 IN HI	J201-V CH15 IN HI	J201-W CHAS GROUND
J200-D CH00 OUT HI	J200-Q CH06 OUT HI	J201-C CH10 IN LO	J201-R CH15 IN LO	J201-W CHAS GROUND
J200-K CH01 IN HI	J200-2 CH06 OUT LO	J201-D CH10 OUT HI	J201-a CH15 OUT HI	J201-W CHAS GROUND
J200-J CH01 IN LO	J200-b CH06 IN HI	J201-K CH10 OUT LO	J201-z CH15 OUT LO	J201-W CHAS GROUND
J200-H CH01 OUT HI	J200-c CH06 IN LO	J201-L CH11 IN HI	J201-b CH16 IN HI	J201-W CHAS GROUND
J200-I CH01 OUT LO	J200-f CH06 OUT HI	J201-M CH11 IN LO	J201-c CH16 IN LO	J201-W CHAS GROUND
J200-L CH01 IN HI	J200-d CH06 OUT LO	J201-N CH11 OUT HI	J201-j CH16 OUT HI	J201-W CHAS GROUND
J200-M CH02 IN HI	J200-m CH07 IN HI	J201-L CH11 OUT LO	J201-d CH16 OUT LO	J201-W CHAS GROUND
J200-N CH02 IN LO	J200-n CH07 IN LO	J201-B CH12 IN HI	J201-m CH17 IN HI	J201-W CHAS GROUND
J200-F CH02 OUT HI	J200-y CH07 OUT HI	J201-M CH12 IN LO	J201-n CH17 IN LO	J201-W CHAS GROUND
J200-N CH02 OUT LO	J200-y CH07 OUT LO	J201-F CH12 OUT HI	J201-v CH17 OUT HI	J201-W CHAS GROUND
J200-P CH03 IN HI	J200-p CH08 IN HI	J201-N CH12 OUT LO	J201-h CH17 OUT LO	J201-W CHAS GROUND
J200-S CH03 IN LO	J200-f CH08 IN LO	J201-P CH13 IN HI	J201-p CH18 IN HI	J201-W CHAS GROUND
J200-Y CH03 OUT HI	J200-f CH08 OUT HI	J201-S CH13 IN LO	J201-q CH18 IN LO	J201-W CHAS GROUND
J200-Y CH03 OUT LO	J200-f CH08 OUT LO	J201-T CH13 OUT HI	J201-r CH18 OUT HI	J201-W CHAS GROUND
J200-U CH04 IN HI	J200-k CH09 IN HI	J201-T CH13 OUT LO	J201-k CH18 OUT LO	J201-W CHAS GROUND
J200-X CH04 IN LO	J200-x CH09 IN LO	J201-Y CH14 IN HI	J201-x CH19 IN HI	J201-W CHAS GROUND
J200-W CH04 OUT HI	J200-f CH09 OUT HI	J201-X CH14 IN LO	J201-x CH19 IN LO	J201-W CHAS GROUND
J200-e CH04 OUT LO	J200-s CH09 OUT LO	J201-e CH14 OUT HI	J201-s CH19 OUT HI	J201-W CHAS GROUND
		J201-e CH14 OUT LO	J201-s CH19 OUT LO	J201-W CHAS GROUND
		J201-w CHAS GROUND	J201-w CHAS GROUND	J201-W CHAS GROUND

PROPRIETARY NOTICE
 THE DOCUMENT AND THE TECHNICAL DRAWINGS DISCLOSED ARE PROPRIETARY TO RACAL INSTRUMENTS INC. AND SHALL NOT, WITHOUT THE EXPRESS WRITTEN PERMISSION OF RACAL INSTRUMENTS INC., BE REPRODUCED, COPIED, OR TRANSMITTED IN ANY MANNER OR BY ANY MEANS, ELECTRONIC OR MECHANICAL, INCLUDING PHOTOCOPYING, RECORDING, OR BY ANY INFORMATION STORAGE AND RETRIEVAL SYSTEM. THIS DOCUMENT IS THE PROPERTY OF RACAL INSTRUMENTS INC. AND IS LOANED TO YOU FOR YOUR USE ONLY. IT IS NOT TO BE DISTRIBUTED TO OTHERS. IT IS TO BE RETURNED TO RACAL INSTRUMENTS INC. UPON COMPLETION OF YOUR PROJECT. RACAL INSTRUMENTS INC. ASSUMES NO LIABILITY FOR ANY DAMAGE TO OR LOSS OF ANY EQUIPMENT OR DATA CAUSED BY THE USE OF THIS DOCUMENT. RACAL INSTRUMENTS INC. IS NOT RESPONSIBLE FOR ANY DAMAGE TO OR LOSS OF ANY EQUIPMENT OR DATA CAUSED BY THE USE OF THIS DOCUMENT. RACAL INSTRUMENTS INC. IS NOT RESPONSIBLE FOR ANY DAMAGE TO OR LOSS OF ANY EQUIPMENT OR DATA CAUSED BY THE USE OF THIS DOCUMENT.

NOTES:
 1. SEE WIRE LIST FOR CONTACT ASSIGNMENTS AND CONNECTIONS.
 2. WHITE INK STAMP J--- APPROXIMATELY WHERE SHOWN.
 3. MARK SIGNAL NAME ON APPROPRIATE SIZE SHRINK TUBING APPROXIMATELY WHERE SHOWN. SEE TABULATION.
 4. SPRAY PROTECTIVE COATING (ITEM 7) AFTER MARKING.

5. CONNECTORS J100-J181 WILL LATER INSTALL IN RECEIVER BLOCK, ITI P/N VGRCB-32CP. MATING ITA CONNECTOR BLOCK IS ITI P/N VGFCB-32CP. MATING ITA PIN IS ITI P/N 602228.
 6. MARK 407277-008 ON APPROPRIATE SIZE SHRINK TUBING APPROXIMATELY WHERE SHOWN. PLACE APPROPRIATE SIZE CLEAR SHRINK TUBING OVER MARKING.

ENGINEERING WIRE LIST

WIRE	FROM	TO	TYPE	PART #	WIRE LEN	REFERENCE	
	BLK AAx PN 01 (J100)	Uxx-SLOT yy (J200)	CABLE	407277-008		SYSTEM WIRE LIST	
	BLK AAx PN 02 (J101)	Uxx-SLOT yy (J200)	CABLE	407277-008			
	BLK AAx PN 03 (J102)	Uxx-SLOT yy (J200)	CABLE	407277-008			
	BLK AAx PN 04 (J103)	Uxx-SLOT yy (J200)	CABLE	407277-008			
	BLK AAx PN 05 (J104)	Uxx-SLOT yy (J200)	CABLE	407277-008			
	BLK AAx PN 06 (J105)	Uxx-SLOT yy (J200)	CABLE	407277-008			
	BLK AAx PN 07 (J106)	Uxx-SLOT yy (J200)	CABLE	407277-008			
	BLK AAx PN 08 (J107)	Uxx-SLOT yy (J200)	CABLE	407277-008			
	BLK AAx PN 09 (J108)	Uxx-SLOT yy (J200)	CABLE	407277-008			
	BLK AAx PN 10 (J109)	Uxx-SLOT yy (J200)	CABLE	407277-008			
	BLK AAx PN 11 (J110)	Uxx-SLOT yy (J200)	CABLE	407277-008			
	BLK AAx PN 12 (J111)	Uxx-SLOT yy (J200)	CABLE	407277-008			
	BLK AAx PN 13 (J112)	Uxx-SLOT yy (J200)	CABLE	407277-008			
	BLK AAx PN 14 (J113)	Uxx-SLOT yy (J200)	CABLE	407277-008			
	BLK AAx PN 15 (J114)	Uxx-SLOT yy (J200)	CABLE	407277-008			
	BLK AAx PN 16 (J115)	Uxx-SLOT yy (J200)	CABLE	407277-008			
	BLK AAx PN 17 (J116)	Uxx-SLOT yy (J200)	CABLE	407277-008			
	BLK AAx PN 18 (J117)	Uxx-SLOT yy (J200)	CABLE	407277-008			
	BLK AAx PN 19 (J118)	Uxx-SLOT yy (J200)	CABLE	407277-008			
	BLK AAx PN 20 (J119)	Uxx-SLOT yy (J200)	CABLE	407277-008			
	BLK AAx PN 21 (J120)	Uxx-SLOT yy (J200)	CABLE	407277-008			
	BLK AAx PN 22 (J121)	Uxx-SLOT yy (J200)	CABLE	407277-008			
	BLK AAx PN 23 (J122)	Uxx-SLOT yy (J200)	CABLE	407277-008			
	BLK AAx PN 24 (J123)	Uxx-SLOT yy (J200)	CABLE	407277-008			
	BLK AAx PN 25 (J124)	Uxx-SLOT yy (J200)	CABLE	407277-008			
RACAL Instruments, Inc., 4 Goodyear St., Irvine, CA 92718							
DOCUMENT TITLE				SIZE	CODE NO.	DOCUMENT NO.	REV
HARNESS ASSY, 1260-20, TTI				A	21793	407277-008	A
				DRN	SHEET 3 of 10		

DOC. NO. 407277-008

ENGINEERING WIRE LIST

WIRE	FROM	TO	TYPE	PART #	WIRE LEN	REFERENCE
	BLK AAx PN 26 (J125)	Uxx-SLOT yy (J200)	CABLE	407277- 008		
	BLK AAx PN 27 (J126)	Uxx-SLOT yy (J200)	CABLE	407277- 008		
	BLK AAx PN 28 (J127)	Uxx-SLOT yy (J200)	CABLE	407277- 008		
	BLK AAx PN 29 (J128)	Uxx-SLOT yy (J200)	CABLE	407277- 008		
	BLK AAx PN 30 (J129)	Uxx-SLOT yy (J200)	CABLE	407277- 008		
	BLK AAx PN 31 (J130)	Uxx-SLOT yy (J200)	CABLE	407277- 008		
	BLK AAx PN 32 (J131)	Uxx-SLOT yy (J200)	CABLE	407277- 008		
	BLK AAx PN 33 (J132)	Uxx-SLOT yy (J200)	CABLE	407277- 008		
	BLK AAx PN 34 (J133)	Uxx-SLOT yy (J200)	CABLE	407277- 008		
	BLK AAx PN 35 (J134)	Uxx-SLOT yy (J200)	CABLE	407277- 008		
	BLK AAx PN 36 (J135)	Uxx-SLOT yy (J200)	CABLE	407277- 008		
	BLK AAx PN 37 (J136)	Uxx-SLOT yy (J200)	CABLE	407277- 008		
	BLK AAx PN 38 (J137)	Uxx-SLOT yy (J200)	CABLE	407277- 008		
	BLK AAx PN 39 (J138)	Uxx-SLOT yy (J200)	CABLE	407277- 008		
	BLK AAx PN 40 (J139)	Uxx-SLOT yy (J200)	CABLE	407277- 008		
	BLK AAx PN 41 (J140)	Uxx-SLOT yy (J200)	CABLE	407277- 008		
	BLK AAx PN 42 (J141)	Uxx-SLOT yy (J201)	CABLE	407277- 008		
	BLK AAx PN 43 (J142)	Uxx-SLOT yy (J201)	CABLE	407277- 008		
	BLK AAx PN 44 (J143)	Uxx-SLOT yy (J201)	CABLE	407277- 008		
	BLK AAx PN 45 (J144)	Uxx-SLOT yy (J201)	CABLE	407277- 008		
	BLK AAx PN 46 (J145)	Uxx-SLOT yy (J201)	CABLE	407277- 008		
	BLK AAx PN 47 (J146)	Uxx-SLOT yy (J201)	CABLE	407277- 008		
	BLK AAx PN 48 (J147)	Uxx-SLOT yy (J201)	CABLE	407277- 008		
	BLK AAx PN 49 (J148)	Uxx-SLOT yy (J201)	CABLE	407277- 008		
	BLK AAx PN 50 (J149)	Uxx-SLOT yy (J201)	CABLE	407277- 008		
RACAL Instruments, Inc., 4 Goodyear St., Irvine, CA 92718						
DOCUMENT TITLE			SIZE	CODE NO.	DOCUMENT NO.	REV
HARNESS ASSY, 1260-20, TTI			A	21793	407277-008	A
			DRN		SHEET 4 of 10	

DOC. NO. 407277-008

ENGINEERING WIRE LIST

WIRE	FROM	TO	TYPE	PART #	WIRE LEN	REFERENCE
	BLK AAx PN 51 (J150)	Uxx-SLOT yy (J201)	CABLE	407277-008		
	BLK AAx PN 52 (J151)	Uxx-SLOT yy (J201)	CABLE	407277-008		
	BLK AAx PN 53 (J152)	Uxx-SLOT yy (J201)	CABLE	407277-008		
	BLK AAx PN 54 (J153)	Uxx-SLOT yy (J201)	CABLE	407277-008		
	BLK AAx PN 55 (J154)	Uxx-SLOT yy (J201)	CABLE	407277-008		
	BLK AAx PN 56 (J155)	Uxx-SLOT yy (J201)	CABLE	407277-008		
	BLK AAx PN 57 (J156)	Uxx-SLOT yy (J201)	CABLE	407277-008		
	BLK AAx PN 58 (J157)	Uxx-SLOT yy (J201)	CABLE	407277-008		
	BLK AAx PN 59 (J158)	Uxx-SLOT yy (J201)	CABLE	407277-008		
	BLK AAx PN 60 (J159)	Uxx-SLOT yy (J201)	CABLE	407277-008		
	BLK AAx PN 61 (J160)	Uxx-SLOT yy (J201)	CABLE	407277-008		
	BLK AAx PN 62 (J161)	Uxx-SLOT yy (J201)	CABLE	407277-008		
	BLK AAx PN 63 (J162)	Uxx-SLOT yy (J201)	CABLE	407277-008		
	BLK AAx PN 64 (J163)	Uxx-SLOT yy (J201)	CABLE	407277-008		
	BLK AAx PN 65 (J164)	Uxx-SLOT yy (J201)	CABLE	407277-008		
	BLK AAx PN 66 (J165)	Uxx-SLOT yy (J201)	CABLE	407277-008		
	BLK AAx PN 67 (J166)	Uxx-SLOT yy (J201)	CABLE	407277-008		
	BLK AAx PN 68 (J167)	Uxx-SLOT yy (J201)	CABLE	407277-008		
	BLK AAx PN 69 (J168)	Uxx-SLOT yy (J201)	CABLE	407277-008		
	BLK AAx PN 70 (J169)	Uxx-SLOT yy (J201)	CABLE	407277-008		
	BLK AAx PN 71 (J170)	Uxx-SLOT yy (J201)	CABLE	407277-008		
	BLK AAx PN 72 (J171)	Uxx-SLOT yy (J201)	CABLE	407277-008		
	BLK AAx PN 73 (J172)	Uxx-SLOT yy (J201)	CABLE	407277-008		
	BLK AAx PN 74 (J173)	Uxx-SLOT yy (J201)	CABLE	407277-008		
	BLK AAx PN 75 (J174)	Uxx-SLOT yy (J201)	CABLE	407277-008		

RACAL Instruments, Inc., 4 Goodyear St., Irvine, CA 92718

DOCUMENT TITLE	SIZE	CODE NO.	DOCUMENT NO.	REV
HARNESS ASSY, 1260-20, TTI	A	21793	407277-008	A
	DRN			SHEET 5 of 10

DOC NO. 407277-008

ENGINEERING WIRE LIST

WIRE	FROM	TO	TYPE	PART #	WIRE LEN	REFERENCE
	BLK AAx PN 76 (J175)	Uxx-SLOT yy (J201)	CABLE	407277-008		
	BLK AAx PN 77 (J176)	Uxx-SLOT yy (J201)	CABLE	407277-008		
	BLK AAx PN 78 (J177)	Uxx-SLOT yy (J201)	CABLE	407277-008		
	BLK AAx PN 79 (J178)	Uxx-SLOT yy (J201)	CABLE	407277-008		
	BLK AAx PN 80 (J179)	Uxx-SLOT yy (J201)	CABLE	407277-008		
	BLK AAx PN 81 (J180)	Uxx-SLOT yy (J201)	CABLE	407277-008		
	BLK AAx PN 82 (J181)	Uxx-SLOT yy (J201)	CABLE	407277-008		
<p>This system wirelist serves as a template for incorporating this harness assembly into the overall system wirelist. It does not in any way affect the fabrication of this harness assembly.</p>						

DOC. NO. 407277-008

RACAL Instruments, Inc., 4 Goodyear St., Irvine, CA 92718				
DOCUMENT TITLE	SIZE	CODE NO.	DOCUMENT NO.	REV
HARNESS ASSY, 1260-20, TTI	A	21793	407277-008	A
	DRN		SHEET 6 of 10	

ENGINEERING WIRE LIST

WIRE	FROM	TO	TYPE	PART #	WIRE LEN	REFERENCE
1	J100 602196-901	J200-A 602200	20 AWG WHT	520999	40"	CH00 IN HI
2	J101 602196-901	J200-C 602200	20 AWG WHT	520999	40"	CH00 IN LO
3	J102 602196-901	J200-D 602200	20 AWG WHT	520999	40"	CH00 OUT HI
4	J103 602196-901	J200-K 602200	20 AWG WHT	520999	40"	CH00 OUT LO
5	J104 602196-901	J200-E 602200	20 AWG WHT	520999	40"	CH01 IN HI
6	J105 602196-901	J200-J 602200	20 AWG WHT	520999	40"	CH01 IN LO
7	J106 602196-901	J200-H 602200	20 AWG WHT	520999	40"	CH01 OUT HI
8	J107 602196-901	J200-L 602200	20 AWG WHT	520999	40"	CH01 OUT LO
9	J108 602196-901	J200-B 602200	20 AWG WHT	520999	40"	CH02 IN HI
10	J109 602196-901	J200-M 602200	20 AWG WHT	520999	40"	CH02 IN LO
11	J110 602196-901	J200-F 602200	20 AWG WHT	520999	40"	CH02 OUT HI
12	J111 602196-901	J200-N 602200	20 AWG WHT	520999	40"	CH02 OUT LO
13	J112 602196-901	J200-P 602200	20 AWG WHT	520999	40"	CH03 IN HI
14	J113 602196-901	J200-S 602200	20 AWG WHT	520999	40"	CH03 IN LO
15	J114 602196-901	J200-T 602200	20 AWG WHT	520999	40"	CH03 OUT HI
16	J115 602196-901	J200-Y 602200	20 AWG WHT	520999	40"	CH03 OUT LO
17	J116 602196-901	J200-U 602200	20 AWG WHT	520999	40"	CH04 IN HI
18	J117 602196-901	J200-X 602200	20 AWG WHT	520999	40"	CH04 IN LO
19	J118 602196-901	J200-W 602200	20 AWG WHT	520999	40"	CH04 OUT HI
20	J119 602196-901	J200-e 602200	20 AWG WHT	520999	40"	CH04 OUT LO
21	J120 602196-901	J200-V 602200	20 AWG WHT	520999	40"	CH05 IN HI
22	J121 602196-901	J200-R 602200	20 AWG WHT	520999	40"	CH05 IN LO
23	J122 602196-901	J200-a 602200	20 AWG WHT	520999	40"	CH05 OUT HI

RACAL Instruments, Inc., 4 Goodyear St., Irvine, CA 92718

DOCUMENT TITLE	SIZE	CODE NO.	DOCUMENT NO.	REV
HARNESS ASSY, 1260-20, TTI	A	21793	407277-008	A
DRN	SHEET 7 of 10			

DOC. NO. 407277-008

ENGINEERING WIRE LIST

WIRE	FROM	TO	TYPE	PART #	WIRE LEN	REFERENCE
24	J123 602196-901	J200-Z 602200	20 AWG WHT	520999	40"	CH05 OUT LO
25	J124 602196-901	J200-b 602200	20 AWG WHT	520999	40"	CH06 IN HI
26	J125 602196-901	J200-c 602200	20 AWG WHT	520999	40"	CH06 IN LO
27	J126 602196-901	J200-j 602200	20 AWG WHT	520999	40"	CH06 OUT HI
28	J127 602196-901	J200-d 602200	20 AWG WHT	520999	40"	CH06 OUT LO
29	J128 602196-901	J200-m 602200	20 AWG WHT	520999	40"	CH07 IN HI
30	J129 602196-901	J200-n 602200	20 AWG WHT	520999	40"	CH07 IN LO
31	J130 602196-901	J200-v 602200	20 AWG WHT	520999	40"	CH07 OUT HI
32	J131 602196-901	J200-h 602200	20 AWG WHT	520999	40"	CH07 OUT LO
33	J132 602196-901	J200-p 602200	20 AWG WHT	520999	40"	CH08 IN HI
34	J133 602196-901	J200-f 602200	20 AWG WHT	520999	40"	CH08 IN LO
35	J134 602196-901	J200-r 602200	20 AWG WHT	520999	40"	CH08 OUT HI
36	J135 602196-901	J200-k 602200	20 AWG WHT	520999	40"	CH08 OUT LO
37	J136 602196-901	J200-x 602200	20 AWG WHT	520999	40"	CH09 IN HI
38	J137 602196-901	J200-t 602200	20 AWG WHT	520999	40"	CH09 IN LO
39	J138 602196-901	J200-s 602200	20 AWG WHT	520999	40"	CH09 OUT HI
40	J139 602196-901	J200-u 602200	20 AWG WHT	520999	40"	CH09 OUT LO
41	J140 602196-901	J200-w 602200	20 AWG WHT	520999	40"	CHASSIS GND
42	J141 602196-901	J201-A 602200	20 AWG WHT	520999	40"	CH10 IN HI
43	J142 602196-901	J201-C 602200	20 AWG WHT	520999	40"	CH10 IN LO
44	J143 602196-901	J201-D 602200	20 AWG WHT	520999	40"	CH10 OUT HI
45	J144 602196-901	J201-K 602200	20 AWG WHT	520999	40"	CH10 OUT LO
46	J145 602196-901	J201-E 602200	20 AWG WHT	520999	40"	CH11 IN HI
RACAL Instruments, Inc., 4 Goodyear St., Irvine, CA 92718						
DOCUMENT TITLE			SIZE	CODE NO.	DOCUMENT NO.	REV
HARNESS ASSY, 1260-20, TTI			A	21793	407277-008	A
			DRN	SHEET 8 of 10		

DOC. NO. 407277-008

ENGINEERING WIRE LIST

WIRE	FROM	TO	TYPE	PART #	WIRE LEN	REFERENCE
47	J146 602196-901	J201-J 602200	20 AWG WHT	520999	40"	CH11 IN LO
48	J147 602196-901	J201-H 602200	20 AWG WHT	520999	40"	CH11 OUT HI
49	J148 602196-901	J201-L 602200	20 AWG WHT	520999	40"	CH11 OUT LO
50	J149 602196-901	J201-B 602200	20 AWG WHT	520999	40"	CH12 IN HI
51	J150 602196-901	J201-M 602200	20 AWG WHT	520999	40"	CH12 IN LO
52	J151 602196-901	J201-F 602200	20 AWG WHT	520999	40"	CH12 OUT HI
53	J152 602196-901	J201-N 602200	20 AWG WHT	520999	40"	CH12 OUT LO
54	J153 602196-901	J201-P 602200	20 AWG WHT	520999	40"	CH13 IN HI
55	J154 602196-901	J201-S 602200	20 AWG WHT	520999	40"	CH13 IN LO
56	J155 602196-901	J201-T 602200	20 AWG WHT	520999	40"	CH13 OUT HI
57	J156 602196-901	J201-Y 602200	20 AWG WHT	520999	40"	CH13 OUT LO
58	J157 602196-901	J201-U 602200	20 AWG WHT	520999	40"	CH14 IN HI
59	J158 602196-901	J201-X 602200	20 AWG WHT	520999	40"	CH14 IN LO
60	J159 602196-901	J201-e 602200	20 AWG WHT	520999	40"	CH14 OUT HI
61	J160 602196-901	J201-W 602200	20 AWG WHT	520999	40"	CH14 OUT LO
62	J161 602196-901	J201-V 602200	20 AWG WHT	520999	40"	CH15 IN HI
63	J162 602196-901	J201-R 602200	20 AWG WHT	520999	40"	CH15 IN LO
64	J163 602196-901	J201-a 602200	20 AWG WHT	520999	40"	CH15 OUT HI
65	J164 602196-901	J201-Z 602200	20 AWG WHT	520999	40"	CH15 OUT LO
66	J165 602196-901	J201-b 602200	20 AWG WHT	520999	40"	CH16 IN HI
67	J166 602196-901	J201-c 602200	20 AWG WHT	520999	40"	CH16 IN LO
68	J167 602196-901	J201-j 602200	20 AWG WHT	520999	40"	CH16 OUT HI
69	J168 602196-901	J201-d 602200	20 AWG WHT	520999	40"	CH16 OUT LO
RACAL Instruments, Inc., 4 Goodyear St., Irvine, CA 92718						
DOCUMENT TITLE			SIZE	CODE NO.	DOCUMENT NO.	REV
HARNESS ASSY, 1260-20, TTI			A	21793	407277-008	A
			DRN	SHEET 9 of 10		

DOC NO. 407277-008

ENGINEERING WIRE LIST

WIRE	FROM	TO	TYPE	PART #	WIRE LEN	REFERENCE
70	J169 602196-901	J201-m 602200	20 AWG WHT	520999	40"	CH17 IN HI
71	J170 602196-901	J201-n 602200	20 AWG WHT	520999	40"	CH17 IN LO
72	J171 602196-901	J201-v 602200	20 AWG WHT	520999	40"	CH17 OUT HI
73	J172 602196-901	J201-h 602200	20 AWG WHT	520999	40"	CH17 OUT LO
74	J173 602196-901	J201-p 602200	20 AWG WHT	520999	40"	CH18 IN HI
75	J174 602196-901	J201-f 602200	20 AWG WHT	520999	40"	CH18 IN LO
76	J175 602196-901	J201-r 602200	20 AWG WHT	520999	40"	CH18 OUT HI
77	J176 602196-901	J201-k 602200	20 AWG WHT	520999	40"	CH18 OUT LO
78	J177 602196-901	J201-x 602200	20 AWG WHT	520999	40"	CH19 IN HI
79	J178 602196-901	J201-t 602200	20 AWG WHT	520999	40"	CH19 IN LO
80	J179 602196-901	J201-s 602200	20 AWG WHT	520999	40"	CH19 OUT HI
81	J180 602196-901	J201-u 602200	20 AWG WHT	520999	40"	CH19 OUT LO
82	J181 602196-901	J201-w 602200	20 AWG WHT	520999	40"	CHASSIS GND
RACAL Instruments, Inc., 4 Goodyear St., Irvine, CA 92718						
DOCUMENT TITLE			SIZE	CODE NO.	DOCUMENT NO.	REV
HARNESS ASSY, 1260-20, TTI			A	21793	407277-008	A
			DRN			SHEET 10 of 10

DOC. NO. 407277-008

Chapter 7

PRODUCT SUPPORT

Product Support

Racal Instruments has a complete Service and Parts Department. If you need technical assistance or should it be necessary to return your product for repair or calibration, call 1-800-722-3262. If parts are required to repair the product at your facility, call 1-949-859-8999 and ask for the Parts Department.

When sending your instrument in for repair, complete the form in the back of this manual.

For worldwide support and the office closes to your facility, refer to the Support Offices section on the following page.

Reshipment Instructions

Use the original packing material when returning the 1260-20 to Racal Instruments for calibration or servicing. The original shipping crate and associated packaging material will provide the necessary protection for safe reshipment.

If the original packing material is unavailable, contact Racal Instruments Customer Service for information.

Support Offices

Racal Instruments, Inc.

4 Goodyear St., Irvine, CA 92618-2002
Tel: (800) 722-3262, FAX: (949) 859-7309

Racal Instruments, Ltd.

480 Bath Road, Slough, Berkshire, SL1 6BE, United Kingdom
Tel: +44 (0) 8706 080134; FAX: +44 (0) 1753 791290

Racal Systems Electronique S.A.

18 Avenue Dutartre, 78150 LeChesnay, France
Tel: +33 (1) 3923 2222; FAX: +33 (1) 3923 2225

Racal Systems Elettronica s.r.l.

Strada 2-Palazzo C4, 20090 Milanofiori Assago, Milan, Italy
Tel: +39 (02) 5750 1796; FAX +39 (02) 5750 1828

Racal Elektronik System GmbH.

Frankenforster Strasse 21, 51427 Bergisch Gladbach, Germany
Tel:+49 2204 92220; FAX: +49 2204 21491

Racal Australia Pty. Ltd.

3 Powells Road, Brookvale, NSW 2100, Australia
Tel: +61 (2) 9936 7000, FAX: +61 (2) 9936 7036

Racal Electronics Pte. Ltd.

26 Ayer Rajah Crescent, 04-06/07 Ayer Rajah Industrial Estate, Singapore 0513.
Tel: +65 7792200, FAX: +65 7785400

Racal Instruments, Ltd.

Unit 5, 25F., Mega Trade Center, No 1, Mei Wan Road, Tsuen Wan, Hong Kong, PRC
Tel: +852 2405 5500, FAX: +852 2416 4335