

GROUND CONTINUITY TESTER

OPERATION AND SERVICE MANUAL

Rod-L Electronics, Inc.
923 Hamilton Avenue
Menlo Park, CA 94025
(415) 322-0711

60002-05
Revised
6 June 1996

CERTIFICATION

Rod-L Electronics, Inc. certifies that this instrument was thoroughly inspected and tested and found to meet its published specifications when it was shipped from the factory.

WARRANTY AND ASSISTANCE

This Rod-L Electronics, Inc. instrument is warranted against defects in materials and workmanship for 5 years following date of delivery. Rod-L Electronics, Inc. will repair or replace this instrument (at our discretion) if proven to be defective during the warranty period provided it is returned to Rod-L Electronics, Inc.

Rod-L Electronics, Inc. recommends that this instrument be calibrated on a 6 month cycle. Under no circumstance should a 12 month cycle be exceeded. This warranty remains valid providing calibration is performed at least once every 12 months by Rod-L Electronics, Inc. or a Rod-L Electronics, Inc. certified calibration service. This warranty is nontransferable and is offered solely to the original purchaser.

This warranty is void if the instrument has been changed, modified, or otherwise altered without the expressed permission of Rod-L Electronics, Inc. Rod-L Electronics, Inc. is not liable for consequential damages. No other warranty is expressed or implied.

Returned Material Authorization must be obtained from Rod-L Electronics, Inc. before returning this instrument for warranty repair. Transportation costs for return of defective instrument for warranty repair must be prepaid and borne by the customer. Rod-L Electronics, Inc. will assume the cost of transportation when returning Warranty Repaired Equipment to the customer. Such method of transportation shall be at the discretion of Rod-L Electronics, Inc.

Table of Contents

Section		Page
1	Introduction	
1-1	Scope of This Manual	5
1-2	General Description and Test Features	5
1-3	Product Specifications (Table 1-1)	6
1-4	Safety Features	7
1-5	Supplied Equipment	7
2	Installation and Operation	
	Safety Warnings	8
2-1	General Information	8
2-2	Unpacking and Inspection	8
2-3	Installation	9
2-4	Power Requirements	9
2-5	Storage	9
2-6	Repackaging for Shipment	9
2-7	Operating Controls	11
2-8	Initial Installation and Power-Up	11
2-9	Operational Check	11
2-10	Total Resistance Trip Set	13
2-11	DUT (Device Under Test) Ground Test	13
2-12	Test Time Adjustment Procedure	14
2-13	Automatic Test Procedure (with a Rod-L Hipot)	15
2-14	GT with M488 Tester Set Up	17
3	Theory of Operation	
3-1	General Introduction	18
3-2	GT Functional Description	18
3-3	GT Electrical Description	19
3-4	A10 Power Supply PCB	20
3-5	A22 Control Logic PCB	20
3-5.1	Total Current Detector	20
3-5.2	Logic Control	20

4	Maintenance and Service	
4-1	Introduction	24
4-2	Equipment Needed	24
4-3	Factory Calibration Procedures	25
4-4	Set Up	25
4-5	Meter Mechanical Zero	25
4-6	Current Meter Calibration	25
4-7	Resistance Calibration	26
4-8	Test Time Calibration	26
4-9	Fail Pots Calibration	26
4-10	List of Adjustment Pots	28
4-11	Trouble Shooting	28

5	Options	
5-1	Remote Control; Options 01 and 19	30
5-1.1	A8 Remote Control PCB Functions	30
5-1.2	A8 Remote Control PCB Theory	30
5-1.3	Analog Option	32
5-1.4	Automatic Reset Option	32
5-2	Option 06, Rear Panel Lockout Cover	33
5-3	Option 07, Extra HV receptacle on Rear Panel	33
5-4	Option 10, Audible Test Tone	33
5-5	Option 15, Rack Mounting	33
5-6	Option 24, Blank FP Start Switch &/or HV Recp	33

6	Bills of Materials, Schematics, Diagrams	
	BOMs for Assy's; Unit, Ship kits, Covers kits, Tested & Untested Units	begin 35
	BOMs for Assy's; Front, Rear, Chassis	begin 42
	BOMs for Assy's; PCBs as plugged in	begin 45
	BOMs for Assy's; HV Recp, Start Switch, Cables, Harnesses	begin 48
	BOMs for Options in Opt # order & with related BOMs	begin 56
	BOMs for Special Units	begin 70
	Wiring Diagrams, Assembly Prints, and Schematics for all PCBs (in same order as BOMs)	begin after 76

List of Figures and Tables

Table 1-1	Model M25 Specifications	6
Figure 2-1	GT Front Panel Controls	10
Figure 2-2	GT Rear Panel Controls	10
Figure 3-1	GT Functional Block Diagram	19
Figure 3-2	General Control Functional Diagram ...	19
Figure 3-3	GT Assembly Diagram	20
Figure 3-4	GT Block Diagram	21
Figure 4-1	Test Set-Up	27

Section 1

INTRODUCTION

1-1. Scope of This Manual

This publication provides operation and service instructions for the **Rod-L Electronics Inc.** Ground Continuity Test Instruments. (It will refer to Model M25, though the M30, M35, and M10 all operate the same. The model number refers to the amount of current it is capable of outputting). The manual is divided into six sections.

- Section 1 - Introduction (capabilities and specifications)
- Section 2 - Installation and Operation
- Section 3 - Theory of Operation
- Section 4 - Service and Calibration
- Section 5 - Options
- Section 6 - Parts Lists, Schematics, Diagrams

1-2. Ground Continuity Tester General Description and Test Features

The **Rod-L** Ground Continuity Test Instruments, Models M25, M30, etc., are rugged, self-contained testers designed for both laboratory and production use. Its purpose is to provide a means for evaluating the ground continuity between a unit's chassis and the ground from the AC power-in cord. This ground must be able to effectively shunt any accidental "leakage" current, usually produced by accidental high voltage spikes, to earth ground.

Certification agencies usually require a 1 ampere ground continuity test to ensure that a ground is capable of diverting any leakage current without getting damaged. Several European and Canadian agencies, including B.S.I., V.D.E., and I.E.C., require a 25 ampere ground continuity test.

The Model M25 Ground Continuity Tester applies a 25 ampere current to the DUT (Device Under Test) for a duration of time, preset from 1 second to 90 seconds. The DUT is plugged into the front panel receptacle (or special rear panel connector option). The total resistance in the ground circuit is measured and displayed on the front panel of the Ground Continuity Tester. Test limits for total resistance are preset by the user via a rear panel control. When the DUT is defective, automatic circuitry turns off the current and meter, turns on a FAIL lamp, and activates an audible alarm. This electronic shutdown circuit turns off the

current within 2ms (two milliseconds) after a fault. These audible and visual alarms must be manually reset at the front panel, or by a Remote Control Option.

Important physical, electrical, and environmental specifications are given in Table 1-1.

1-3. Product Specifications (Table 1-1)

Table 1-1: Model M25 Specifications

Test Voltage and Current	at 0.1 Ω load; 3 VAC RMS, 25 A RMS, 50/60 Hz
Voltage Shutdown	Within 2 milliseconds after a fault or end of test is detected (electronic shut down circuits)
Test Time	1 second to 90 seconds (adjustable)
Initial Turn-On Period	Allow 5 seconds warm-up
Ohm Meter	0 - 0.15 Ω , \pm 5% F.S. accuracy
Ammeter	Up to 40 amps (user specified) \pm 5% F.S. accuracy
Input Power	115/230 VAC, 44-66 Hz., 360 watts, max
Environmental Operating Temperature	0° to 50° C, 32° to 122° F
Exterior Color	Mint grey / Olive grey
Weight	35 lbs (13.5 kg) net
Dimensions	16.75 x 13.25 x 5.5 inches (43 x 34 x 14 cm)

1-4. Safety Features

- A) Loss of Ground connection terminates test cycle
- B) Front panel receptacle accepts 3-pronged power cord from DUT providing maximum safety and significantly reduces time required to perform the test
- C) Recessed START button
- D) Visual alarm at failure
- E) Audible alarm at failure
- F) Fast electronic shut down of voltage
- G) Hard RESET after failure required to perform next test
- H) Complete discharge of Device Under Test (DUT)

1-5. Supplied Equipment

- A) Ground Continuity Tester, Model M25, M30, M35, or M10
- B) Power Cord, three pronged, 6 ft
- C) High Current Ground Sense cable, 18 in
- D) HV Interface Cable (interfaces to Hipot)
- E) Operation/Service Manual
- F) Extra fuse set for the alternate AC supply voltage

Section 2

INSTALLATION AND OPERATION



The exclamation point within a triangle is intended to tell the user that important operating and servicing instructions are in the papers that are provided with the equipment.

WARNING

Verify that the voltage selector switch is positioned and the correct power supply cord is selected to match the voltage source.

WARNING

This product is shipped with a high voltage mating plug and cap installed on the rear panel HV OUT/INTERFACE connector. To reduce the risk of shock, this plug and cap must be used whenever the high voltage interface cable is not installed.

In addition, the high voltage interface cable must only be used when both ends are terminated at their respective equipment connectors. To reduce the risk of electric shock, the equipment must not be operated with one end not terminated.

2-1. General Information

This section contains the recommended procedures for unpacking, inspection, installation, operation, storage, and reshipment.

2-2. Unpacking and Inspection

A shipping carton that appears damaged should be inspected and unpacked with the carrier's agent present. Inspect the instrument for damage (scratches, dents, broken knobs or meters, etc.)

If the instrument is found to be damaged upon receipt, notify the carrier and Rod-L Electronics immediately. Retain the shipping carton and the padding material for the carrier's inspection, and for return shipment.

2-3. Installation

The Rod-L Ground Continuity Test Instrument is suitable for either bench or rack mounting. To rack mount the instrument, use Option 15A. The instructions for rack mounting are on page 33.

2-4. Power Requirements

The Ground Continuity Tester requires a power source of either 115 or 230 volts AC, 44 to 66 Hz single-phase. Prior to applying power to the instrument, ensure the AC line voltage selector switch on the Rear Panel is in the appropriate position. Also, the AC power socket to which the Ground Continuity Tester connects must have a functioning safety ground.

To protect operating personnel, NEMA, the National Electrical Manufacturers Association, recommends that the instrument panel and cabinet be grounded. The Ground Continuity Tester is equipped with a 3-conductor power cord, which, when plugged into an appropriate receptacle, grounds the instrument. The offset pin on the 3-prong connector is the ground pin.

2-5. Storage

It is strongly recommended that the Ground Continuity Tester be packed as if for reshipment. Environmental conditions during storage and reshipment should be as follows:

- A) Maximum temperature: 167°F (75°C)
- B) Minimum temperature: -40°F (-40°C)

2-6. Repackaging for Shipment

If possible, use the original shipping container and packing materials. Otherwise:

- A) Wrap the Ground Continuity Tester in heavy paper or plastic before placing it in the shipping container.
- B) Use plenty of packing material around the instrument, and protect the front panel with cardboard or plastic bubble packing. Protect the instrument with two inch rubberized foam pads placed along all surfaces of the instrument, or with a layer of excelsior about 6 inches thick packed firmly against all surfaces of the instrument.

Figure 2-1: Ground Continuity Tester Front Panel Controls

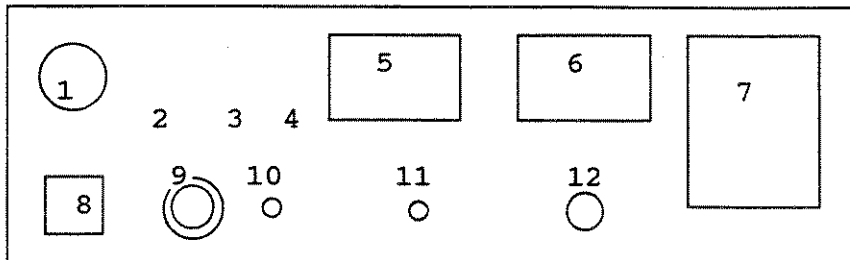

- 1. Alarm emits audible signal on failure
- 2. READY lamp comes on at power up
- 3. TESTING lamp on during a test
- 4. FAIL lamp on if a test fails
- 5. Current (I) meter indicates current (in AC Amps)
- 6. Ohm (R) meter provides direct Resistance reading of DUT's ground loop
- 7. HV Output Block receptacle for DUT's 3-pronged AC power line
- 8. LinePower switch turns on and indicates line power input
- 9. START switch initiates Ground Continuity Test if instrument is grounded properly and not already indicating a ground-test failure
- 10. RESET button resets Ground Continuity Tester
- 11. A/B switch chooses Function; Ground Continuity Test only or Ground Continuity Test and Hipot Test
- 12. Chassis Ground Sense for DUT chassis ground connection

Figure 2-2: Ground Continuity Tester Rear Panel Controls

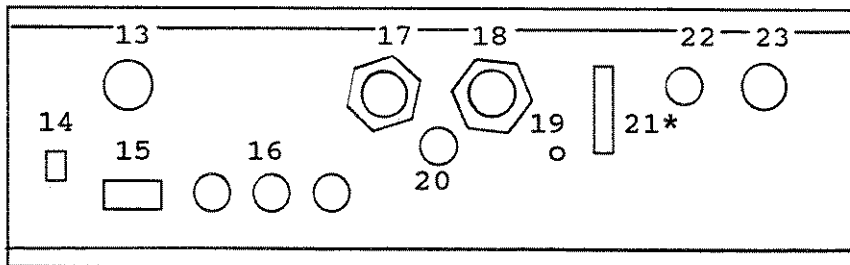

- 13. Low Line Switch S5 compensates for Low Line Voltage inputs; normal, -8%, or -16%
- 14. Voltage Selector Switch chooses 115VAC or 230VAC input; be sure to install correct fuses
- 15. AC line power in receptacle
- 16. AC Fuses F1/F2 3A @ 115VAC, 2A @ 230VAC; F3 .5A @ 115/230VAC
- 17.* HV Out connector (*Optional) hipot HV for Leakage Tester(LT) use
- 18. HV Interface connector for AC Hipot Interface
- 19. Ground jack for connecting chassis' of other testers
- 20. Ground Sense jack connects to Ground Sense of Hipot Tester
- 21.* Remote connector (*Optional) for remote interface
- 22.* Current In jack (*Optional) for input of current from the LT
- 23. Ohms Trip pot R5 calibrates Ohms Trip setting

- C) Use a strong, well-sealed shipping container (350 lb/sq in. bursting test).
- D) Mark the container "FRAGILE - DELICATE INSTRUMENT."

2-7. Operating Controls

The Front panel and rear panel controls are shown in Figures 2-1 and 2-2.

WARNING

This instrument to be used ONLY in THREE WIRE GROUNDED OUTLETS. It is recommended that periodic checks of the outlet and the ground wire be made to ensure operator safety.

2-8. Initial Installation and Power-Up

The Ground Continuity Tester is shipped configured for 115 VAC operation. Appropriate fuses (1.5 ampere) are also provided for 230 VAC operation. Before applying 230 VAC power to the instrument, perform the following:

CAUTION

Changing Fuses: Turn off the Ground Continuity Tester and DISCONNECT THE POWER CORD. Then install the proper fuses. Otherwise, damage to the instrument and/or operator could result.

2-9. Operational Check

This is an operator oriented procedure which allows operational check of the Rod-L Ground Continuity Tester without test equipment. Refer to Section 4 of this manual for a complete calibration procedure.

Place the instrument in a sturdy position, preferably on an insulated surface, with all surrounding metal/conductors grounded. Position the power cord so as to avoid being walked on or pinched by other equipment.

- A) Set LINE POWER switch to OFF.

- B) Validate that the fuses are the proper values.
- C) Verify Input Line Voltage Select Switch position.
- D) Set the OHMS TRIP control to full clockwise position.
- E) With an AC voltmeter, check the primary power line for normal line voltage conditions.
- F) Set the VOLTAGE ADJ switch on the rear panel to appropriate position if the AC input is low line.
- G) Connect AC Power Cord between the AC receptacle on the rear panel and an AC power source.
- H) Set LINE POWER switch to ON.
 - a) The lamp should light.
 - b) The green READY lamp should also illuminate.

NOTE: *If the power ON lamp remains off, check for proper AC line voltage.*

- I) Insert the banana plug of the High Current Chassis Ground Cable into the *Chassis Ground Sense* banana jack. Connect the clamp of that cable to any exposed metal part of the Ground Continuity Tester.
- J) Insure that "OHM TRIP" on the rear panel is set to "10," the maximum.
- K) Push the START button.
 - a) The Testing Lamp should come on for approximately 5 seconds.
 - b) Current Meter should read approximately 30 amps.
 - c) Ohmmeter should read less than .01 Ω . Keep in mind, this reading is with *NO LOAD*. Record this reading on page 13, Section 2-11.
- L) Set "Total Ohm Trip" pot to the minimum, "0."
- M) Push the START button.
 - a) The alarm should sound.
 - b) The red FAIL lamp should illuminate.

NOTE: *If this setting is left as is, turning the M25 off and then on again may cause it to fail as soon as it is turned on.*

- N) Press the RESET button.
 - a) The alarm should go off.
 - b) The red FAIL lamp should go off.

- O) If the above conditions are met, the Ground Continuity Tester is operating properly. If your normal operating voltage is different from what is specified above, refer to Set Up Procedures (4-4), page 25.

2-10. Total Resistance Trip Set

The BSI standard states that the resistance to be measured shall not exceed $(0.1 + R)\Omega$, where R is the resistance of the supply cord. The high current grounding cable must also be considered, and this resistance was measured in Section 2-10, K, c) on page 12.

Each division on the scale of the Total Current Trip pot represents approximately .015 Ω , and this scale is non-linear to the pot.

For accurate failure points, a known value of resistance should be inserted into the Continuity Loop. The trip point pot can then be adjusted from above until a failure is indicated, or in other words, while the test is running, set the trip point pot high enough so that there is no failure, then turn the pot slowly down until a failure occurs.

2-11. DUT (Device Under Test) Ground Continuity Test

- A) Plug the power cord of the DUT into the 3-pronged receptacle on the front panel of the Ground Continuity Tester.
- B) Insert the banana plug of the High Current Chassis Ground Cable into the *Chassis Ground Sense* banana jack.
- C) Connect the clamp of that cable to any exposed metal part of chassis of the DUT. Make sure connections are solid.
- D) Push the START button.
- a) The Testing Lamp should come on.
 - b) If the total resistance of the DUT does not exceed the setting of the Trip pot, the test will run approximately 5 seconds.
 - 1) The Ammeter will indicate the current through the Ground Loop.
 - 2) The Ohmmeter will indicate the resistance of the Ground Loop of the DUT.
 - c) If the total resistance of the DUT is higher than the Trip pot setting, a failure indication will be given, both audible and visual.

d) To test devices that do not have a 3-pronged supply cable, make a suitable grounding cable by using 3 layers of 3/16" flat tinned copper braid tubing, and 2 (each) 25amp battery clamps. To perform a Ground Continuity Test under these conditions:

- 1) Connect banana plug of High Current Cable to the Ground Continuity Tester banana jack.
- 2) Connect clamp to the chassis of DUT.
- 3) Connect one clamp of the cable just made to DUT ground, and other clamp to the chassis of the Ground Continuity Tester. Proceed with Step 3-13,D. (Remember to compensate Trip point for resistance of the newly made cable).

2-12. Test Time Adjustment Procedure

The Test Time Adjustment potentiometer is factory set for 5 to 7 seconds. Reset this control as necessary in accordance with the regulatory agency suggested test time for the DUT.

To reset the test time duration, proceed as follows:

- A) Turn OFF power to the Ground Continuity Tester.
- B) Remove top cover and locate Test Time Adjustment potentiometer, R22 on the A22 Control Logic PCB.
- C) Set the Ground Continuity Tester up for a Ground test; either chassis self-test, or with a device to be tested.
- D) Reapply power to the Ground Continuity Tester.

CAUTION

Do not touch any of the other potentiometers on the PCBs. Otherwise, the calibration of the instrument will be destroyed.

- E) Use a stopwatch to time how long the TESTING lamp remains lit. By adjusting R22 on the A22, and timing the TESTING lamp duration with the stopwatch, any Test duration can be set between 1 second and 90 seconds.

2-13. Automatic Test Procedure: Using the Ground Continuity Tester with a Rod-L Hipot

See the drawings at the rear of this manual, #s 01075-01 and 01076-01. One of these drawings should enable setting up of a Ground Continuity Tester and Hipot Tester for use in tandem.

Connect the Remote Control Cable (with 25p D Sub miniature connector) to the Ground Continuity Tester, and a remote operating device if the Ground Continuity Tester is equipped with Option 01 or 19.

Make sure that the Ground Continuity/Hipot Tester Interface Cable (4pin LGH connector) is in place.

Ensure the Testers are connected to the same AC Line Power source.

Turn AC power switch of the Ground Continuity Tester on first.

NOTE: *If the Hipot is turned on first, the Hipot Tester may immediately start a test when the Ground Continuity Tester is turned on, and high voltage will appear on both output receptacles.*

Then turn on the power switch of the Hipot Tester.

The DUT (Device Under Test) should be plugged into the Ground Continuity Tester receptacle for sequential testing, i.e., Ground Continuity Test first, and then the Hipot Test.

If the Hipot Test only is preferred, the test must be initiated at the Hipot Tester. (The DUT can still be plugged into the Ground Continuity Tester).

A failure of the Ground Continuity Test will not allow the Hipot Test to start. If a failure occurs in the Ground Continuity Test or the Hipot Test, a RESET on the Ground Continuity Tester must be initiated before any further testing can be done. If the Hipot Tester is equipped with the Automatic Reset Option, when a failure occurs in the Hipot Test only, the Tester will automatically reset in 3 seconds.

If the Hipot Tester's Chassis Ground voltage is not connected to BP-2, the Rear Panel Banana Jack of the Ground Continuity Tester, the READY light of the Hipot Tester should not come on, and no Hipot Test can be initiated from the Ground Continuity Tester. If the Hipot Tester's chassis Ground voltage is connected to BP-2, the total safety Ground return, from the DUT to the Hipot Tester, is tested, and the READY light should be on if this resistance is

less than the Hipot Tester's setting (0.5Ω standard). It is assumed that the Hipot Tester controls are already set up according to the respective Operation Manual.

Push the START button on the Ground Continuity Tester.

The READY light of the Hipot Tester should go off since the Safety Ground Return Test from the DUT is taken over by the Ground Continuity Tester using the relays K1 and K2 (see drawing # 00941-XX, or if none, then 00431-XX). The Safety Ground Return is connected to the Ground Continuity Tester Chassis and the Chassis Ground voltage output through BP-1 is connected to the High Current Transformer.

The TESTING light of the Ground Continuity Tester comes on and the Ground Continuity Test is performed. Should a failure occur, the Ground Continuity Tester has to be manually RESET. No Hipot Tester will be automatically started if that occurs.

Put front panel switch in Ground/Hipot Test position for sequential testing. If Ground Continuity Test only is performed, place the switch in the ground position. Sequential testing, or Ground (Continuity only) Test, will be initiated by starting the Ground Continuity Tester. The Hipot Tester's Chassis Ground voltage must be connected to BP-2, the Rear Panel Banana Jack of the Ground Continuity Tester.

If the Ground Continuity Test performs successfully, the TEST light will go off after the preset time. Then the READY light on the Hipot Tester will go on as the Hipot Tester takes over the Safety Ground Return Test. Because the relays K1 and K2 in the Ground Continuity Tester return to normal position, the Safety Ground Return is connected to the Hipot Tester Chassis through the HV Return wire, and the Chassis Ground voltage output BP-1 is connected to BP-2 where the Chassis Ground voltage of the Hipot Tester is connected.

After about 1 second the Hipot Tester is started automatically from the Ground Continuity Tester. The Hipot Tester test light comes on and continues to perform as specified in the respective manual. Pressing the RESET button on the Ground Continuity Tester can, at any given moment, reset the Hipot Tester.

2-14. Ground Continuity Tester with M488 Tester Set Up

The Ground Continuity Tester to Hipot Tester Interface Cable, and the connection between the M488's Chassis Ground and the Ground Continuity Tester BP-2 Rear Panel Banana Jack should be made as described above in section 2-14.

The Ground Continuity Tester must be equipped with Option 01 Remote Control, and the 25-pin Remote connectors on the rear panels of both instruments must be connected together.

Turn the Power Switch of the M488 on first. Then turn on the Ground Continuity Tester.

The DUT (Device Under Test) should be plugged into the Ground Continuity Tester receptacle for sequential testing, i.e., Ground Continuity Test first, and then the Hipot Test.

Sequential testing will be initiated by starting the M488 Hipot Tester according to the instructions described in the M488 Operations Manual.

The A8 Remote PCB should be adjusted, if needed, for putting out 10 VDC when a 0.1Ω load resistor is used. This is for the M488 monitoring of the resistance. Refer to the Options Section, page 30.

Section 3

THEORY OF OPERATION

3-1. General Introduction

This section concerns the circuit theory for the Ground Continuity Tester. This system was designed to ensure high quality, accuracy, flexibility, and safety of operation.

The Grounding system of any electrical product is important in keeping all operator-accessible dead metal parts grounded so that, should insulation fail, hazardous levels of voltage and current would be shunted to "earth" ground. Of course, electrostatic charges and induced electromagnetic eddy currents would also be "earthed."

The Ground Continuity Tester tests the reliability (in the event of a failure) of a Grounding System in an electrical / electronic product; that is, the current carrying capacity. In this manual, we shall refer to this product as the DUT (Device Under Test). The Ground Continuity Tester supplies a test current amplitude which is sufficiently high to effectively "burn out" weak spots in a DUT's Grounding System. The Ground Continuity Tester test also measures the actual resistivity to assure a sound path for current flow to the "earth" ground.

If this Amp Ground Continuity Test is performed before a Hipot (or High Voltage Potential or Dielectric Withstand) Test, it ensures the safety and protection of users during subsequent hipot and leakage current tests. (25 amps at only 3 volts cannot harm any user).

3-2. Ground Continuity Tester Functional Description

Functionally, the Ground Continuity Tester is divided into 3 sections: the High Current Generator, General Control, and an optional Remote Control.

The High Current Generator consists of an AC transformer (50/60 Hz) specially designed to provide the current needed in the Ground Continuity Test. It is activated through a solid state optically isolated relay during an AC input line zero crossing after the corresponding signal is given by the General Control.

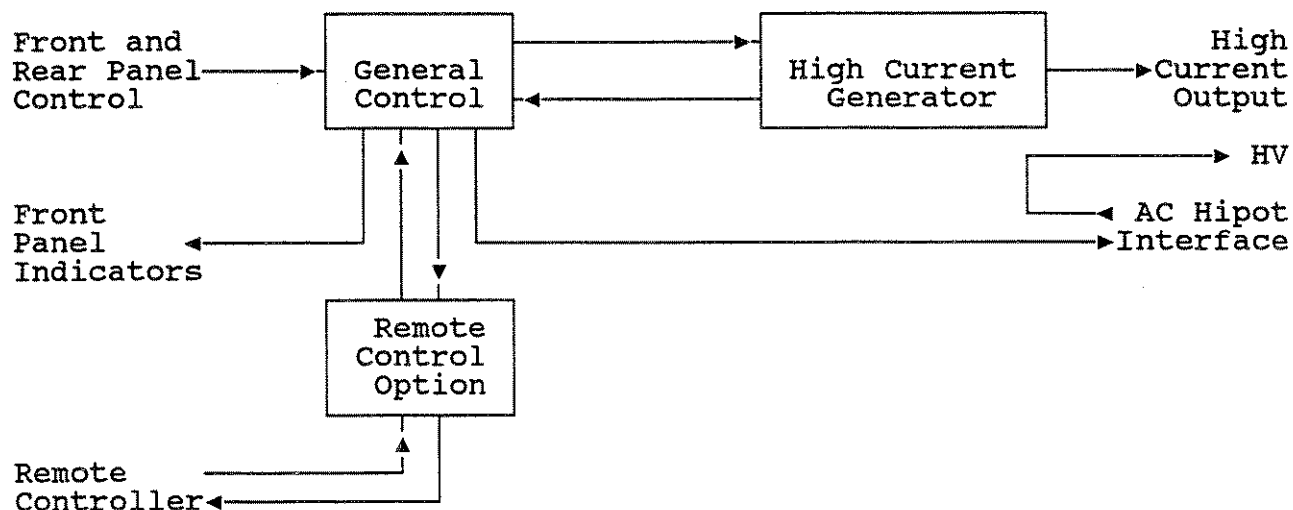

Figure 3-1: Ground Continuity Tester Functional Block Diagram

The General Control performs the coordination of the different activities and monitoring as shown in Figure 3-2. The control can be commanded from the respective front and rear panel controls shown on the left side of the diagram. It takes care of coordinating the different activities and sensing the status of the operation. It provides continuous monitoring through the front panel lights, buzzer, and meters shown on the right side of the figure.

The Remote Option is an isolated interface for most of the control and monitor signals.

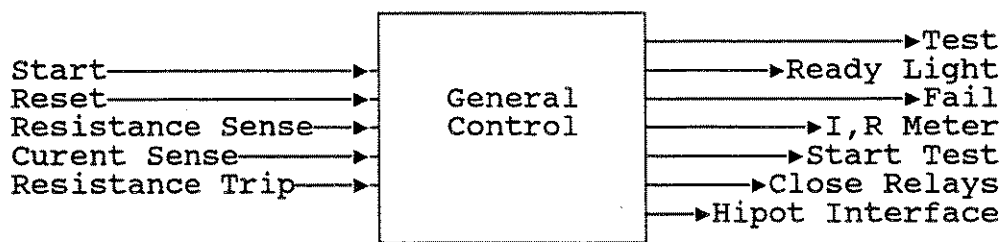

Figure 3-2: General Control Functional Diagram

3-3. Ground Continuity Tester Electrical Description

The Ground Continuity Tester is divided into 2 sections as shown in Figure 3-3. The left side of the diagram is physically separated and contains an A26 Mother PCB, A22 Control Logic PCB, and an A10 Power Supply PCB. It can also contain an A8 Remote

Control PCB. The right side of the figure contains the electrical transformers, relays, and current sense resistors.

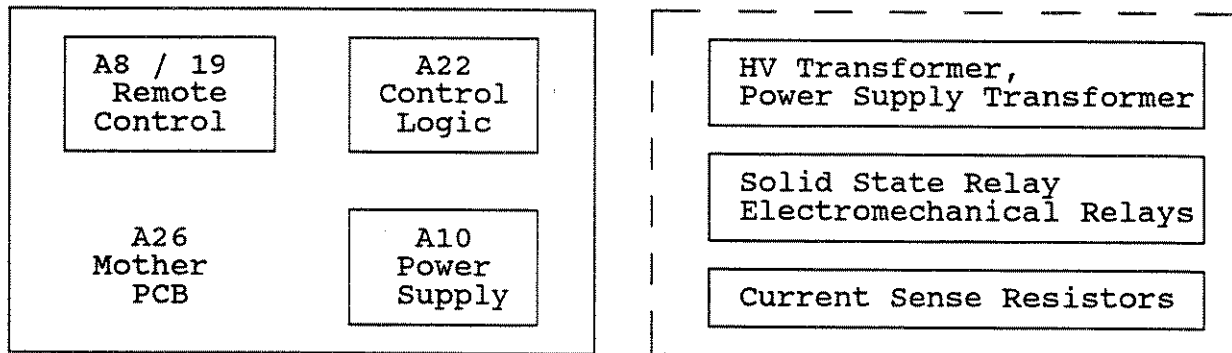

Figure 3-3: Ground Continuity Tester Assembly Diagram

3-4. A10 Power Supply P. C. Board

3-4.1. Description

The A10 generates the regulated +5VDC, +15VDC, and -15VDC power supplies that are used throughout the unit.

3-4.2. Theory

With reference to schematic # 00978-01, the different AC voltages are full wave rectified by U1, 2, and 3, and they are filtered and regulated by VR1, 2, and 3.

3-5. A22 Control Logic P. C. Board

3-5.1. Total Current Detector

The A22 Control Logic PCB receives the voltage from across the current sense resistor set. This resistor set is composed of 8 resistors (on the Ground Continuity Tester, 6-12 on other models), each valued at 2Ω 50W, giving a total resistance of 0.25Ω .

3-5.2. Logic Control

As shown on schematic # 00972-XX, the A22 receives all switch inputs and monitor outputs from the fail comparator. It controls the duration of the test and stops the test when there is an operator reset or fail condition. This PCB keeps the failure signal present until there is a manual reset from the user. It also includes a zero crossing detector using an 18VAC input, and a start generator.

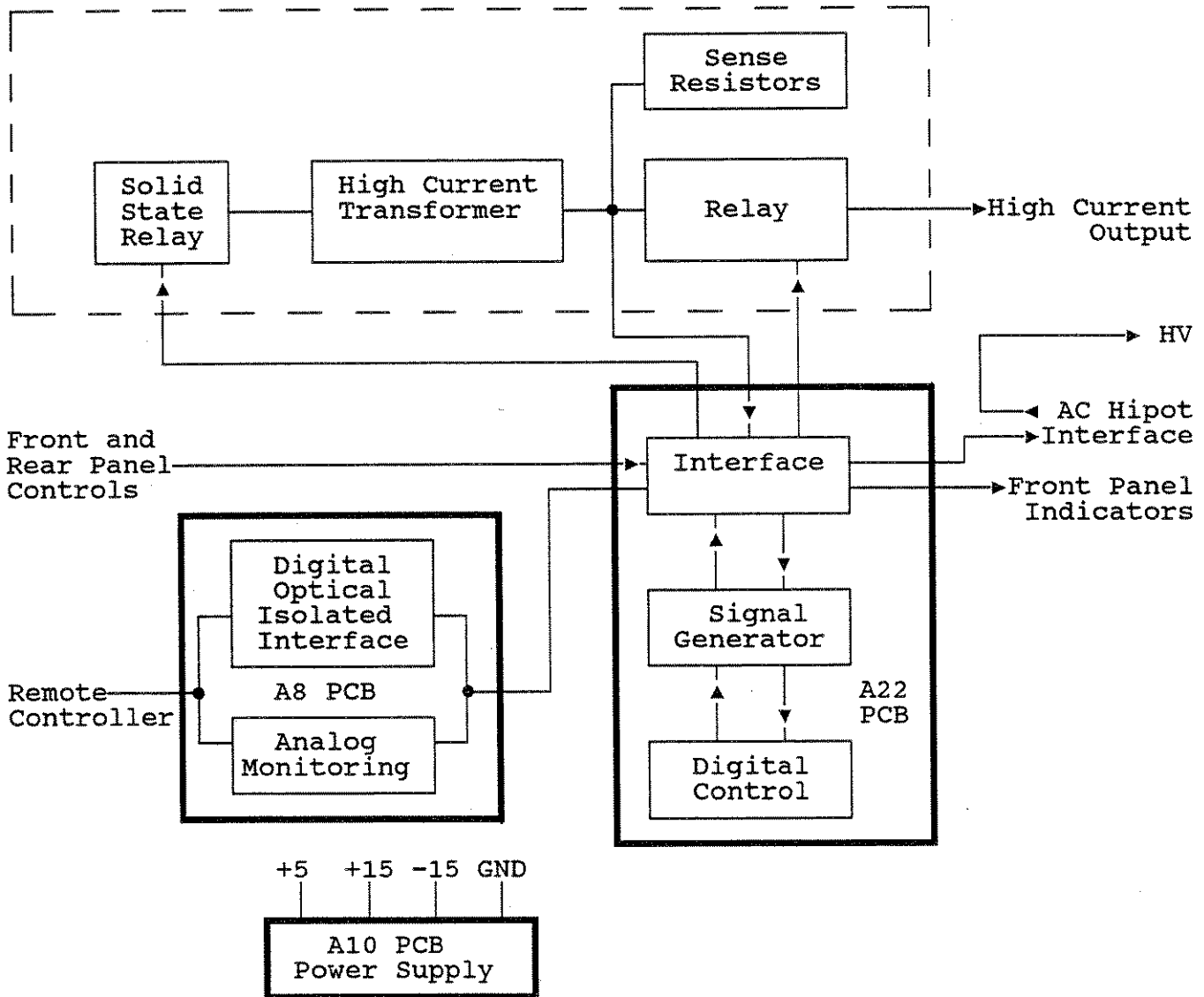

Figure 3-4: Ground Continuity Tester Block Diagram

There are three digital inputs: *START*, *RESET*, and the *FAILURE* from the resistance comparator, U9.

There are status and control outputs: *TEST LIGHT*, *REMOTE TEST*, *FAIL*, *AC HIPOT START*, *AC HIPOT RESET*, *RELAYS*, and an optional pulsing-tone drive.

3-5.3. Theory

Referencing schematic # 00984-XX, with the *START* input from the Edge-card connector Pin 9, two NAND gates (U5, U6) provide a hysteresis buffer. U5-11 (U5, pin 11) provides the *TEST* latch which drives transistor, Q1, to provide a *REMOTE TEST* signal for the Remote Option. U5-11 also drives U7 which drives the *RELAYS* through Edge-card connector Pin D.

The Relays (K1, K2) are high current type, referred to on drawing # 00941-01. When activated, they connect the High Current Transformer to the Output Receptacle, and connect the HV Return on the Front Panel Receptacle Block to the Chassis of the Ground Continuity Tester. When the relays are deactivated, (if the Ground Continuity Tester is interfaced with the Hipot Tester) the high current output is connected to 1.5 VAC Chassis Ground Sense Voltage of the Hipot, and the HV Return is connected to the HV Return of the Hipot. This makes possible performance of a continuous 1 amp Chassis Ground Sense Test during the Hipot Test. It also allows a separate Return, for the high voltage test, from the DUT to the Hipot Tester.

The *START* signal also triggers the DELAY timer, U11, for setting up the RELAYS, and at the end of the delay, the *START PULSE* timer is triggered. This pulse gates the zero crossing pulses produced by Q8, and triggers the TEST TIMER, U11. The duration of the test is controlled by the pot R22. The output of the TEST TIMER drives the *TEST LIGHT* through U8 and drives the analog switches in U3 for enabling the monitoring of current and resistance.

The FAIL LATCH can be set by the output of the resistance comparator in U9, driving the *FAIL* signal through U7. The FAIL LATCH is composed of two NAND gates in U6. The latch can be reset by the *RESET* signal coming through Edge-card connector Pin 5.

The Fail Latch also operates the *SYSTEM RESET* through U10-2 (U10, pin 2). This gate gathers the different signals that can reset the system: the Reset Switch, the Fail Latch, and the Test signal from the Test Timer. The Test signal is fed through a network that produces a pulse at U10-4,5 at the End Of Test, resetting all the timers and the Test Latch. This Reset is also transmitted to the Hipot Tester (when interfaced) through the optical isolator, U2.

At the end of a successful Test, the signal from U5-11 (the Test Latch) goes through a network that produces a pulse at U12-8, triggering a Delay Timer which sets the Hipot before a Start signal is produced by U11. The Delay Timer triggers the Trigger Timer, U11, which produces the *Start Hipot* signal, through the optical isolator, U1. These timers are reset by the system RESET, as in the above paragraph. C22 is larger than C10 to insure the generation of the *Start Hipot* signal even if the system Reset is generated by the End Of Test signal only.

The *Remote* signal at Edge-card connector Pin C can activate the transistor, Q2, when no remote programming is desired, connecting Pin C to +5V. This will put a low level at U3-6 (U3, pin 6) (opening contact C), and a high level at U3-12, (closing contact D). The opposite occurs when the Edge-card connector Pin C is tied to Ground, selecting Remote Programming.

Section 4 MAINTENANCE AND SERVICE

WARNING

These Service Instructions are for use by qualified personnel ONLY. To avoid electric shock, do not perform any servicing other than that contained in the operating instructions unless you are qualified to do so!

4-1. Introduction

This section provides maintenance and service information for the Rod-L Ground Continuity Tester. Included is a list recommended test equipment, trouble shooting procedures, calibration procedures, and adjustment data.

Rod-L recommends that the ground continuity testers be calibrated on a 6 or 12 month cycle at the discretion of the customer based on volume of usage. Under no circumstance should a 12 month cycle be exceeded.

4-2. Equipment Needed

The following equipment will be needed to complete the factory calibration procedures:

- A) Oscilloscope
- B) Digital Multi-Meter (DMM) (Voltage floating input)
(Ammeter RMS reading)
- C) 115 - 230 VAC Line Step Up Transformer
- D) AC Variac
- E) AC Current Sensor (American Aerospace Controls, Inc.
1003A MI-50 or equivalent)
- F) Calibration Standard Resistor 1%: 0.1 Ω 50W
(The accuracy of the Ground Continuity Tester ohmeter depends on accurately determining the value of this resistor. Several resistors of close, yet slightly different value are recommended)

4-3. Factory Calibration Procedures

There are five major calibration points on the Ground Continuity Tester. They are:

- A) Meter Mechanical Zero
- B) Current Meter Calibration
- C) Resistance Meter Calibration
- D) Test Time Calibration
- E) Fail Pot Calibration

4-4. Set Up

The equipment should be set up to ensure testing at 115 VAC or minus 1% (low line switch = "Normal"). Remember to set the line switch to 115 or 230 VAC position depending on the AC input line voltage. It is recommended that calibration be done with the same line input voltage as would be used for normal operation. If line frequency is different from 60Hz, remember that required capacitor values will change.

4-5. Meter Mechanical Zero

With the Ground Continuity Tester turned OFF, note the positions of the ohmmeter and ammeter pointers on the front panel. They should read 0 ± 1 minor division. If they do not, adjust the null screw.

4-6. Current Meter Calibration

Turn the M25 ON and note that the Ammeter Pointer is at 0 ± 1 minor division. The READY light should be on. If not, trouble shoot the A10 Power Supply PCB or the READY light driver on the A22 Control Logic PCB. Insure that the calibration load (see Section 4-2,F) is connected between the Front Panel Receptacle 25 Amp output and the Front Panel Receptacle HV Return (chassis handle could also be used) through the AC Current Sense as shown in Figure 4-1. Turn the OHM TRIP potentiometer fully CW (clockwise).

Push the START button.

The ammeter should deflect to about 25 amperes. The DVM connected with the AC Current Sensor should agree with the ammeter reading within 3%F.S. (Full Scale). If they don't agree, adjust the pot R25 on the A22 PCB until they do.

Push the RESET button.

4-7. Resistance Calibration

- A) Confirm that the current meter has been calibrated as described in Section 4-6.
- B) Connect the 0.1Ω test load as shown in Figure 4-1, page 27.
- C) Initiate the test cycle and make note of the maximum output current while the test is in progress.
- D) Connect an AC voltmeter between the Front Panel Chassis Ground Sense connector and the ground pin of the Front Panel High Voltage Receptacle (best recommendation is on the inside of the front panel).
- E) Initiate the test cycle and make note of the maximum voltage between these two points (step D).
- F) Using the equation $R = V/I$ — where R is load resistance, V is the voltage measured in step E), and I is the current measured in step C) — calculate the load resistance.
- G) Initiate the test cycle and adjust the pot R21 on the A22 PCB until the reading on the resistance meter agrees with the resistance calculated in step F).

4-8. Test Time Calibration

To set a specific test time, follow the instructions in Section 2-12, page 14.

To check test time limits, turn TEST TIME pot R22 on the A22 Control Logic PCB to minimum (fully CW) and maximum (CCW). Minimum should be 1 second and maximum about 90 seconds. If not, troubleshoot timer or call a Rod-L Applications Engineer for assistance.

4-9. Fail Pots Calibration

Turn the OHM TRIP potentiometer on the Rear Panel fully CW (clockwise). With no load connected to the Ground Continuity Tester output, push the START button. The resistance meter should deflect to F.S. (full scale) and a failure mode produced; i.e., constant alarm sound and FAIL light on. Push RESET.

Connect the calibration load to the Ground Continuity Tester output as described in Section 4-6. Push the START button. While the test light is ON, slowly turn the OHM TRIP pot CCW until a failure mode is produced. Push RESET.

Figure 4-1: Test Set-Up

- R25 Current Meter Calibration
- R24 max trip available adjustment
- R22 Test Time Adjustment
- R21 Resistance Meter Calibration

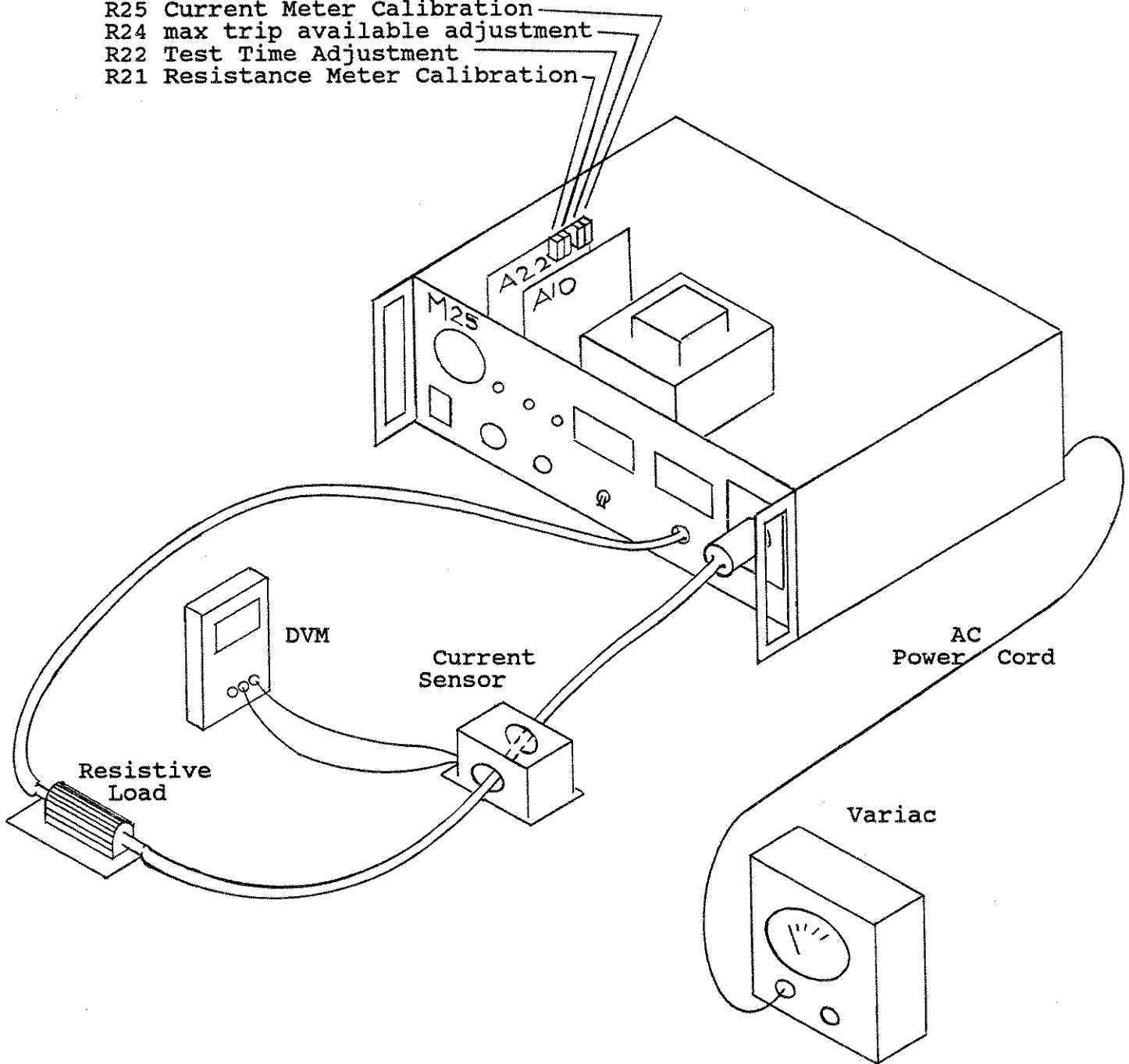

R24 on the A22 Control Logic PCB controls the **MAXIMUM OHM TRIP POINT**, which is the highest resistance level to which the Ohm Trip Pot on the Rear Panel can be set. It should be set before setting the Ohm Trip Point with the Ohm Trip Pot on the Rear Panel. When set at the factory, a load equivalent to the F.S., (usually a 0.15Ω resistor) is used as a calibrating load with the OHM TRIP pot fully CW. Then, when the START button is pushed, the resistance meter should deflect to F.S., and a failure mode be produced. If a failure mode is not produced when the meter is deflecting to F.S., then adjust R24 until it is. Then Push RESET and proceed with Resistance Calibration.

4-10. List of Adjustment Pots

- | | |
|-----------------------|-------------------------------|
| A) R25 on the A22 PCB | Current Meter Calibration |
| B) R24 on the A22 PCB | Maximum Resistance Trip Point |
| C) R22 on the A22 PCB | Test Time Adjustment |
| D) R21 on the A22 PCB | Resistance Meter Calibration |

4-11. Trouble Shooting

Below is a list of problems, probable causes, and remedies for fault location. It should assist the technician in isolating a fault location. This table does not tabulate all the possible symptoms; only those Customer Service has determined most likely to occur.

A) No AC Power

- 1) Check fuses F1 and F2.

Recommended Fuses:

F1,2	115VAC	3A Slow blow
F3	115VAC	.5A Slow blow
F1,2	230VAC	2A Slow blow
F3	230VAC	.5A Slow blow

- 2) Check for bad AC Power Switch (S1) or Line Filter.
- 3) Measure for line voltage between Pin 1 of the solid state relay, K3, and Neutral.

B) Ground Continuity Tester blows fuses

- 1) Check for correct fuses.
- 2) Check for shorted varistors on the A7 PCB.
- 3) Troubleshoot the A10 Power Supply PCB.

C) Ready Lamp does not work

- 1) Check for burnt out bulb.
- 2) Check for bad +5V.
- 3) Check the driver on the A22 PCB.

D) No High Current Output

- 1) Check for bad start switch.
- 2) Check wiring harness for frayed wiring.
- 3) Check the solid state Relay, K3, and the triggering signal from the A22 PCB, pin 11.

E) No High Current with Failure Indication

- 1) Check OHM TRIP pot position. (see Section 4-9)
- 2) Check Load connection between the 25 amp output and the HV Return.
- 3) Check relays closure before the High Current Generation

Section 5

OPTIONS

5-1. Remote Control; Options 01 and 19

The Ground Continuity Tester has remote control capability when one of the Remote Options is used. It would include another PCB, and the signals would come through a DB-25 connector on the rear panel.

Several versions of the Remote Option are available (see schematic 01208-XX or 01306-02 or 00980-XX:) first, either Option 01 Digital or Option 19 Analog and Digital; second, with/without Automatic Reset Option; and third, with/without Pass Signal. The A8 Remote Control PCB is configured differently for the various combinations available.

5-1.1. A8 Remote Control P. C. Board Functions

The *digital* functions concern the status of the instrument and are available with Option 01. There are three inputs: *START*, *RESET*, and *SELECT A*. There are three outputs: *READY*, *TEST*, and *FAIL*. These signals are TTL compatible and optically isolated.

The *analog* functions provide buffering and adjustable gain for the resistance and current signals. The resistance buffer gain is adjusted to get 10VDC out of U11-10 (U11, pin 10) on the A8 PCB for a load of 0.1 Ω .

The *Automatic Reset Option* makes the *FAIL* signal short in duration, and generates a *RESET* pulse after a failure is latched in the A22 Control Logic PCB. At the end of the *Fail* pulse, the system is completely Reset if no restart is attempted.

5-1.2. A8 Remote Control P. C. Board Theory

The *START* input starts a test cycle during the low to high transition. It has to remain high for about 15ms minimum.

RESET resets all Ground Continuity Tester operations when a high level is held.

TEST is a low level output when a test is in progress.

FAILURE is output at low level whenever there is an abortive condition during a test.

SELECT A, when held low, selects the Gnd Test / Hipot Test selection, and when high, selects Gnd Test only.

REMOTE (or *REM* on older units) selects the remote analog monitoring capability when a high level input is held.

The input current requirements for the digital signals are:

High Level	40uA @ +5V
Low Level	1.6mA @ 0.4V

The output current capabilities for the digital signals are:

High Level	2.27mA @ +5V
Low Level	2.27mA max @ +5V

When U3 is driven, a *RESET* signal is produced at Edge-card connector Pin 5, either directly through C, D jumpers or through U1 when the Automatic Reset Option is installed.

When U2 is driven, a *START* signal exits Edge-card connector Pin 9. (U9 driving is used only for M100/500 Hipot Tester versions of the PCB).

When the *GROUND TEST* signal through Edge-card connector Pin 10 is low, U6 is activated, and a low level is available at Edge-card connector Pin L to the Remote Connector.

When *TEST*, from Edge-card connector Pin 11, is low, i.e., a Test in Progress, U7 is activated, and a low level is available from Edge-card connector Pin M to the Remote Connector.

When U8 is activated by the *FAIL* signal, either from Edge-card connector Pin 12 or Edge-card connector Pin B when the Automatic Reset Option is used, a low level is available from Edge-card connector Pin N to the Remote Connector.

The Remote Controller's 5V and GND are fed through Edge-card connector Pins K and 15 respectively. The rest of the DB-25 pin assignments for using the A8 PCB are shown below:

<u>DB 25 Pin #</u>	<u>Signal Name</u>	<u>Analog/Digital</u>
1	EXTGND (Digital Supply)	
2	RMON	A
3	IMON	A
4	GND (GT Chassis)	
5 - 15	not used	
16	EXTGND (Digital Supply)	
17	REM	D
18	RESET	D
19	START	D
20	EXT +5V (Digital Supply)	
21	-READY	D
22	-TEST	D
23	-FAILURE	D
24		
25	SELECTA	D

5-1.3. Analog Option

When the M488 is interfaced with the Ground Continuity Tester, the A8 Remote Control PCB uses U11 as a non-inverting buffer with adjustable gain. R26 is adjusted for getting 10VDC out of Edge-card connector Pin 10 for 0.1Ω resistance. The resistance monitoring signal comes from the A22 Control Logic PCB through Edge-card connector Pin 7. R24 is for adjusting I MON OUT to 10VDC when there is no load on the output. R25 is for adjusting R MON OUT to 10VDC when a 0.1Ω load is connected at the output.

5-1.4. Automatic Reset Option

Referring to the A8 PCB schematic, 00980-XX, while in the TEST mode, a FAIL produces a one shot negative pulse in U4. The falling edge produces a one shot pulse in U5 which drives the alarm through Edge-card connector Pin B with Q2, and resets the system through the Edge-card connector Pin 5 with U1. At the end of the pulse from U5, the system is RESET and the alarm turned off. U1 also resets the system when REMOTE RESET is produced. If this Option is not needed, A, B, C, and D jumpers are placed so that the FAIL signal drives the alarm as normal, and the reset from the remote goes directly to the RESET line.

5-2. Option 06, Rear Panel Lockout Cover

Option 06 is a lexan cover for the rear panel controls. It is installed by removing the top cover to add the standoff hardware to the rear panel.

5-3. Option 07, Extra HV receptacle on Rear Panel

This option provides the rear panel with another 4-pin High Voltage receptacle. It is installed at the factory.

5-4. Option 10, Audible Test Tone

When Option 10 Audible Test Tone is installed in a Ground Continuity Tester, the alarm will sound pulses at 3 to 6 beeps per second whenever a TEST is in progress. This feature is produced by an additional IC and other discreet components on the A22 Control Logic PCB. A timer in U12 generates a pulse train signal, and Q5 drives the signal through Edge-card connector Pin 1 when the Test Latch is set.

5-5. Option 15, Rack Mounting

To rack mount the instrument, use Option 15 A. The procedure for installing the Rack Mounting Kit on the Ground Continuity Tester is as follows:

- A) Remove Extrusion insert (2 each) from both sides of instrument
- B) Place L-Bracket (2) and secure to chassis with four machine screws furnished with Mounting Kit
- C) Check that the screws and brackets are firmly secure

5-6. Option 24, Blank Front Panel Start Switch and/or HV Recp Block

This option removes the start switch, the front panel High Voltage receptacle, or both. A blank plate is installed, instead.

Section 6

BILLS OF MATERIALS, SCHEMATICS, DIAGRAMS

Following are M25 Bills Of Materials for help in identifying typical Rod-L part numbers.

Rod-L Electronics, Inc. -- Bill Of Materials
00701-01 Mdl M 25 25 Amp 0.15 Ohm Ground Tester

Rod-L P/N	Description	qty	Reference
00888-01	Assy Unit M 25 Tested Ground Tester	1.0	Unit
01163-01	Assy Kit Covers @ ButtonUp 5"H units <ND>	1.0	ButtonUp
01170-02	Assy Kit Ship M 25 Box w/ Accessories	1.0	Shipping
REV-A	NIN Rev-A This Assy is at Rev-A	0.0	

Rod-L Electronics, Inc. -- Bill Of Materials
 01170-02 Assy Kit Ship M 25 Box w/ Accessories

od-L P/N	Description	qty	Reference	R
0667-14	Box Shipping 13"x 18"x 21"Letrd M100sA,G,D,R,I,J	1.0	Box	5
0663-11	Foam Shipping EndCap M100 5.5"	2.0	Box	5
7152-01	NIN Envelope 'Packing Slip' Clear Front,Stick Back	1.0	Box	7
0502-01	Bag poly clear 2mil x2x3 w/sealing	1.0	Bag	5
0502-05	Bag poly clear 2mil x4x6 w/sealing	1.0	Bag	5
0015-01	Asm Cable Power AC std 18AWG 1250W 7.5'L	1.0	Power Cord	5
0326-24	Asm Cable Jumper 18AWG StakngBana/StkngBana 24"blk	1.0	Jumper Cable	5
0333-03	Assy Cable Interface M25 to Hipot 3pHVcon(2ea) 16"	1.0	Hipot Intrfc Cable	0
0436-02	Assy Cable Hi Cur Gnd GiantBanaPlug/BatteryClip 4'	1.0	Ground Cable	0
0909-01	Label 'Alert I!' instruction in manual (for UL)	1.0	Label	0
1347-01	Label 'Stop! Use correct voltage/fuse' blk on yelo	1.0	Label	0
0683-01	Label 'Calibration' green & white	1.0	Certification label	5
1372-01	Label 'This product is U.L....' 2x5.5 box outside	1.0	Box label	0
0002-05	Manual M25 Ground Continuity Tester 6 June 96	1.0	Manual	6
0074-01	NIN Form Certificate Technical	1.0	Certification	9
NE-EACH	NIN Of the Following Parts, Only what is Ordered:	0.0	SEE BELOW!!!	0
0063-02	Fuse slo blo .50A 250V 3AG .25x1.25"	1.0	For 115V or 230V Op	5
0063-05	Fuse slo blo 2.00A 250V 3AG .25x1.25"	2.0	S/B for 115V Op	5
0063-08	Fuse slo blo 3.00A 250V 3AG .25x1.25"	0.0	For 230V Op	5
EV-A	NIN Rev-A This Assy is at Rev-A	0.0		R

Rod-L Electronics, Inc. -- Bill Of Materials
 01163-01 Assy Kit Covers @ ButtonUp 5"H units <ND>

Rod-L P/N	Description	qty	Reference
01160-01	Assy Plate Cover Bottom w/ Feet & Stand Instru <ND	1.0	Bottom Cover
01161-01	Assy Plate Cover Top w/ Foam Instrument <ND>	1.0	Top Cover
00455-01	Assy Handle Instrument	2.0	Handle
00339-06	Asmy Plate Cover SideRear Fab vinylBlk2.5x4.5 M100	2.0	SideRear Covers
00338-06	Asmy Plate Cover SideFrnt Fab vnyl black2x4.5 M100	2.0	SideFront Covers
00340-06	Asmy Plate Retainr Handl Fab vinyl Blk 4.5x5 M100	2.0	Handle Covers
50301-01	Asm Kit Con-Cover Cutout DB25 black plastic	1.0	Remote Cover
00858-01	Plate Decor Side Strip .833x4.5" alum no glue ALL	2.0	Side Strip
00620-01	Grip 2.3"L 'A' Plastic Black Molded SideFrame	2.0	Grip
00620-02	Grip 2.3"L 'B' Plastic Black Molded SideFrame	2.0	Grip
50573-01	Nut Push-On U-shape Clip # 6 black Tinnerman	4.0	HW Top & Bottom Cover
50544-01	Nut Kep 4-40 x .250 (1/4) O.D.	2.0	HW Remote Cover
50530-02	Screw PanSem Phl 4-40 x .250	2.0	HW Remote Cover
50532-02	Screw PanSem Phl 8-32 x .250	4.0	HW Handle Covers
50779-02	Screw Fl Hd 100d Phl 6-32 x .250	16.0	HW Side Covers
50779-04	Screw Fl Hd 100d Phl 6-32 x .500	4.0	HW Top & Bottom Cover
REV-A	NIN Rev-A This Assy is at Rev-A	0.0	

Rod-L Electronics, Inc. -- Bill Of Materials
 01160-01 Assy Plate Cover Bottom w/ Feet & Stand Instru <ND

od-L P/N	Description	qty	Reference	
0342-06	Asmy Plate Cover Bot Fab'd 11x16 vinyl black M100	1.0	Cover	01
0619-01	Assy Foot Instrument w/Rivit, Spring, & Washer	5.0	Foot	01
0444-09	Stand Tilt Wire Form Instrument	1.0	Stand	01
EV-A	NIN Rev-A This Assy is at Rev-A	0.0		RI

Rod-L Electronics, Inc. -- Bill Of Materials
00455-01 Assy Handle Instrument

Rod-L P/N	Description	qty	Reference
00669-02	Asmy Handle Instrumnt Finsh (Buffed w/LaborOutside	1.0	Buffed Handle
00668-01	Spring Wire Torsion 3.2" Crooked Ends Handle	1.0	Spring
00857-01	Grip Handle 4.4" L plastic Instrument	1.0	Grip
		1.0	Add Label 00667-01
REV-A	NIN Rev-A This Assy is at Rev-A	0.0	

Rod-L Electronics, Inc. -- Bill Of Materials
 00888-01 Assy Unit M 25 Tested Ground Tester

od-L P/N	Description	qty	Reference	R
0887-01	Assy Unit M 25 Untested Ground Tester	1.0	Untested Unit	0
0949-01	Assy PCB A26 Mother GT Ground Tester	1.0	A26 PCB Assy	0
0459-02	Assy PCB A10 Power Supply	1.0	A10 PCB Assy	0
0972-01	Assy PCB A22 Control Logic GT	1.0	A22 PCB Assy	0
0530-02	Screw PanSem Ph1 4-40 x .250	4.0	HW A26	5
EV-A	NIN Rev-A This Assy is at Rev-A	0.0		R

Rod-L Electronics, Inc. -- Bill Of Materials
00887-01 Assy Unit M 25 Untested Ground Tester

Rod-L P/N	Description	qty	Reference
00672-01	Assy Plate Front M 25	1.0	Front Panel Assy
00673-01	Assy Plate Rear M 25	1.0	Rear Panel Assy
00674-01	Assy Plate Chassis M 25	1.0	Chassis Assy
00343-05	Asmy Plate Frame Side 5x13 fin & polshd M100s	2.0	Frames
00647-01	Label Model No., Logo, U.L. Logo: 1x3 on Pin Feed	2.0	S/N
50532-02	Screw PanSem Phl 8-32 x .250	4.0	HW Frames
50778-03	Screw Fl Hd 100d Phl 8-32 x .375	18.0	HW Frames
90072-01	NIN Form Traveler Mfg Ord, Prod Tst, QC Data M25	1.0	Traveller
REV-A	NIN Rev-A This Assy is at Rev-A	0.0	

Rod-L Electronics, Inc. -- Bill Of Materials
 00672-01 Assy Plate Front M 25

rod-L P/N	Description	qty	Reference	
00996-01	Assy Harness Plate Front M 25	1.0	Wiring	
00164-39	Plate Front M 25 Mint Grey screened	1.0	Front Panel	
00671-01	Assy Con Recp Hi Voltage Block 3P FP All Units	1.0	J2 (Recp)	
00977-01	Assy Switch START Rev A ALL Instruments	1.0	S4 (Start)	
01139-01	Bracket L-Shape 1hole ea side .5Wx.5x.35 mtg ALL	8.0	M1,2,J2	
00608-25	Label Desc and Test Status M 25	1.0	FP Label	
00177-01	Con Jack Banana Giant black HH Smith 286-103	1.0	BP1	
00449-05	Con Terminal Strip 5lug, 1gnd mtg, solder type	1.0	TS1	
00565-02	Switch Toggle DPDT 125VDC O-N-O Alco MTA 206A	1.0	S4 (Gnd/Hipot)	
00710-01	Switch Rocker SPDT w/ Lamp 125VAC sqPnlMnt WireLug	1.0	S1 (AC ON)	
00555-01	Switch PushButton Momntry SPDT wiringLug C&K 8121Z	1.0	S3 (Reset)	
00007-01	Button Red .375 dia x.25 Tall C&K 7527-RED	1.0	S3 (Reset)	
00193-01	Lamp Incand Amber flat cylind lens pnl mnt 6"Leads	1.0	I3 (Test)	
00193-02	Lamp Incand Green flat cylind lens pnl mnt 6"Leads	1.0	I2 (Ready)	
00193-03	Lamp Incand Red flat cylind lens pnl mnt 6" Leads	1.0	I4 (Fail)	
00520-01	Alarm 3-30VDC Sonalert AI 380	1.0	AL1	
00204-45	Meter Analog w/scale 0- 40 A AC	1.0	M1 (Cur)	
00207-02	Meter Analog w/scale 0- .15ohm	1.0	M2 (R)	
00204-00	Meter Analog 0-1mA misc scale KYCO 7521	0.0	M1,2	
00202-03	Lug Solder # 6 1 solder hole, 1 internal lock	6.0	AL1,M1,2	
00173-05	Washer Shoulder # 6 .375 x.031 x.093 nylon	4.0	M1,2	
00588-07	Washer Split-Lock # 10 bronze	1.0	BP1	
00827-01	Nut Push-On Flat 3/16" Clip	3.0	I2-4	
00530-02	Screw PanSem Phl 4-40 x .250	4.0	J2	
REV-B	NIN Rev-B This Assy is at Rev-B	0.0	Sq Sw, Brackets	

Rod-L Electronics, Inc. -- Bill Of Materials
00673-01 Assy Plate Rear M 25

Rod-L P/N	Description	qty	Reference
00997-01	Assy Harness Plate Rear M 25	1.0	Wiring
00463-11	Plate Rear M 25 Ground Continuity T (RevL) screend	1.0	Rear Panel
50706-03	Pot K 10 10 turns pnl mnt 3 lug 2W .875 x.75	1.0	R5 (Ohm Trip Point)
50227-01	Knob Dual Counting Dial w/ Brake 020H 1413-66123	1.0	R5 (Ohm Trip Point)
50527-01	Con Post Binding/StdBanaJack blk .94"base.875"L#10	1.0	BP2
50509-01	Con Recp 4p Cylind HV Housing PnlMtg blk plst Amp	1.0	J4 (HV Recp)
50451-01	Con Nut 1" for HV Con blk plastic	1.0	J4 (HV Recp)
50049-01	Con PowerEntryInt'l Filter 3p115/250VAC 60hz8200pF	1.0	J1 (filter)
50295-01	Con Post Binding/StdBanJk(orPhon/Lug/Clip)8-32octa	1.0	Ground BP
50075-01	Fuse-Holder Littlefuse 342014	3.0	F1-3
50063-02	Fuse slo blo .50A 250V 3AG .25x1.25"	1.0	F3
50063-08	Fuse slo blo 3.00A 250V 3AG .25x1.25"	2.0	F1,2 (for 115V)
50063-05	Fuse slo blo 2.00A 250V 3AG .25x1.25"	0.0	F1,2 (for 230V)
50556-01	Switch Rotary 1P11T 1deck 2"shaft CentraLab PA1001	1.0	(HV Adj)
50560-01	Switch Slide 4PDT 115/230VAC Sel Sw.Crft47227LFE	1.0	A7
50331-01	Relay 250VAC 10A 3-32VDC Control Gordos GA5-4D10	1.0	K1
50191-02	Knob .75 OD x.5 D x.62hi .25 shaft Flange Pointer	1.0	S5 (lo V)
50202-03	Lug Solder # 6 1 solder hole, 1 internal lock	3.0	Ground Lugs
50258-07	Rivet .250" L .120" dia stem A7 Switch	2.0	A7
50585-05	Washer Star # 6	1.0	Ring lug Ground
50074-12	Washer Flat 3/8ID 5/8 OD steel zinc pltg	1.0	(HV Adj)
50587-20	Washer Internal Lock .875 OD x.53125 ID	3.0	F1-3
50544-02	Nut Kep 6-32 x .312 (5/16) O.D.	5.0	J1 (filter), Gnd Lugs
50544-03	Nut Kep 8-32 x .344 (11/32) O.D.	1.0	Ground BP
50544-05	Nut Kep 6-32 x .250 (1/4) O.D.	2.0	K1
50531-03	Screw PanSem Phl 6-32 x .375	6.0	J1 (fltr),GndLugs,K1
REV-A	NIN Rev-A This Assy is at Rev-A	0.0	

Rod-L Electronics, Inc. -- Bill Of Materials
 00674-01 Assy Plate Chassis M 25

Id-L P/N	Description	qty	Reference	RE
0998-01	Assy Harness Plate Chassis M 25	1.0	Wiring	00
0447-05	Plate Chassis M 25	1.0	Chassis Plate	00
0226-07	Trnsfrmr 22W: 18(2),8,1.38V RevB AC,GT PS Q 4495	1.0	PS XF	00
0226-07A	Trnsfrmr 22W 115(2):24,17.1(2),8.5,1.38V M3.125X	0.0	or PS XF	00
0661-01	Trnsfrmr 370W 120(2),110(2),100(2):9.24V GT HI4146	1.0	H I XF	00
0365-03	Res Ohm 2 50W 1% WW pnl mtg	8.0	R3s	50
0449-05	Con Terminal Strip 5lug, lgnd mtg, solder type	1.0	TS1	50
0542-08	Con Barrier Strip 8-32 9/16 CC 8pos TRW 8-542	1.0	BS1	50
0344-01	Relay 12VDC Rate:10a 110VAC,7.5a 220VAC,10a 30VDC	2.0	K1,2	50
0515-01	Relay-Socket 14 holes for wiring SH4B-05	2.0	K1,2	50
0518-01	Relay-Hold-Down Clips (2ea) for 50344-01 SFA-101	2.0	incl. 2 / relay	50
0202-03	Lug Solder # 6 1 solder hole, 1 internal lock	2.0	Chassis Ground	50
0074-10	Washer Flat #10 3/8 OD steel zinc pltg	4.0	H I XF	50
0074-11	Washer Flat # 6 1/4 OD steel zinc pltg	4.0	K1,2	50
0585-04	Washer Star # 4	1.0	Ground Lug	50
0544-01	Nut Kep 4-40 x .250 (1/4) O.D.	17.0	R3s, Grnd Lug	50
0544-05	Nut Kep 6-32 x .250 (1/4) O.D.	8.0	K1,2,BS1	50
0544-03	Nut Kep 8-32 x .344 (11/32) O.D.	3.0	PS XF, Ground	50
0544-04	Nut Kep 10-32 x .375 (3/8) O.D.	4.0	H I XF	50
0530-03	Screw PanSem Phl 4-40 x .375	17.0	R3s, Grnd Lug	50
0531-07	Screw PanSem Phl 6-32 x .875	4.0	BS1	50
0589-10	Screw Rnd Hd Slit 6-32 x 1.250	4.0	K1,2	50
0532-03	Screw PanSem Phl 8-32 x .375	2.0	PS XF	50
0532-04	Screw PanSem Phl 8-32 x .500	1.0	Ground	50
0533-04	Screw PanSem Phl 10-32 x .500	4.0	H I XF	50
IV-A	NIN Rev-A This Assy is at Rev-A	0.0		RE

Rod-L Electronics, Inc. -- Bill Of Materials
 00949-01 Assy PCB A26 Mother GT Ground Tester

Rod-L P/N	Description	qty	Reference
00974-01	NIN Diag Wire PCB A26 Mother Interconnection GT	0.0	Reference
00431-03	PCB Fab A26 Mother M25 (RevD)	1.0	A26 PCB Fab
50409-01	Con Cardedge 30p 15pos PCB mtg pins no Ears	2.0	A10,22
50222-08	Con Header w/FricLock lro .100"C/C .025"sq 8p M	2.0	Chassis, PS XF
50222-12	Con Header w/FricLock lro .100"C/C .025"sq 12p M	2.0	FP,RP
50071-01	Con Guide PCB 3" L 4-40 mtg SAE 1250V	4.0	A10,22
50151-01	Pin-Micro Test .070dia .3/.062 ID x.145 gold	2.0	Test Pins
50817-02	Jumper Wire #22 AWG .2" long	1.0	Set,Reset
50612-01	Standoff 4-40 x .375 x.25 OD FF hexBrassCad	4.0	Mounting
50530-02	Screw PanSem Phl 4-40 x .250	8.0	A10,22
REV-D	NIN Rev-D This Assy is at Rev-D	0.0	

Rod-L Electronics, Inc. -- Bill Of Materials
 00459-02 Assy PCB A10 Power Supply

od-L P/N	Description	qty	Reference	R
0978-01	NIN Schem PCB A10 Power Supply	0.0	Reference	00
0459-03	PCB Fab A10 Power Supply (RevB)	1.0	A10 PCB Fab	00
0130-01	IC V Reg +5 TO-220 UA7805 or LM340T5	1.0	VR1	50
0123-01	IC V Reg -15 TO-220 7915 or K1703-B or LM320T-15	1.0	VR2	50
0169-01	IC V Reg +15 TO-220 UA7815	1.0	VR3	50
0830-01	Fuse-Pico 4A 125V Littlefuse 275004 (251004?)	1.0	F1	50
0030-01	Diode-Bridge CSB05 70V 1A	3.0	U1-3	50
0032-01	Diode 1N4002 Rec 100V 1A	3.0	CR1-3	50
0324-04	Cap 3000 uF 16VDC 10% elect axial	1.0	C1	50
0060-01	Cap 1 uF 35V 10% tant axial	3.0	C2,3,6	50
0320-04	Cap 470 uF 25VDC 20% elect axial	2.0	C4,5	50
0151-01	Pin-Micro Test .070dia .3/.062 ID x.145 gold	4.0	TP1-4	50
0544-01	Nut Kep 4-40 x .250 (1/4) O.D.	3.0	VR1-3	50
0530-02	Screw PanSem Ph1 4-40 x .250	3.0	VR1-3	50
EV-B	NIN Rev-B This Assy is at Rev-B	0.0		R1

Rod-L Electronics, Inc. -- Bill Of Materials
00972-01 Assy PCB A22 Control Logic GT

Rod-L P/N	Description	qty	Reference
00984-01	NIN Schem PCB A22 Control Logic	0.0	Reference
00973-07	PCB Fab A22 Control Logic (RevG)	1.0	A22 PCB Fab
50128-01	IC Op Amp Lo Power quad LM324	2.0	U4,9
50077-01	IC Switch Bilateral CMOS quad CD4066B	1.0	U3
50092-01	IC Timer dual NE556	1.0	U12
50093-01	IC Timer quad NE558	1.0	U11
50135-01	IC NAND 2-In quad 7400	2.0	U5,6
50142-01	IC NAND 4-In dual 7420	1.0	U10
50167-01	IC Driver Peripheral dual 75452	2.0	U7,8
50079-01	IC Optical Coupler H11B1	2.0	U1,2
50264-06	IC-Socket 6p Lo Profile .3 DIP	2.0	X1,2
50264-08	IC-Socket 8p Lo Profile .3 DIP	2.0	X7,8
50264-14	IC-Socket 14p Lo Profile .3 DIP	7.0	X3-6,9,10,12
50264-16	IC-Socket 16p Lo Profile .3 DIP	1.0	X11
50337-01	ResPak SIP K 2.2 8p 4r 1%	1.0	RP1
50338-04	ResPak SIP K 3.3 8p 4r 1%	1.0	RP8
50335-02	ResPak SIP K 4.7 8p 4r 1%	2.0	RP2,6
50335-01	ResPak SIP K 10 8p 4r 1%	3.0	RP4,9,10
50338-03	ResPak SIP K 20 8p 4r 1%	1.0	RP5
50338-01	ResPak SIP K 22 8p 4r 1%	1.0	RP7
50339-01	ResPak SIP K 47 8p 4r 1%	1.0	RP3
50702-07	Pot K 10 20 turns offset pins rectangle	2.0	R21,25
50708-01	Pot K 500 20 turns offset pins rectangle	1.0	R24
50702-12	Pot Meg 1 20 turns offset pins rectangle	1.0	R22
50125-08	Res Ohm 100 1/4W 5% CC	1.0	R10
50125-15	Res Ohm 470 1/4W 5% CC	1.0	R1
50125-31	Res K 1 1/4W 5% CC	2.0	R4,14
50125-32	Res K 1.2 1/4W 5% CC	1.0	R3
50125-40	Res K 4.7 1/4W 5% CC	5.0	R8,9,28,31,32
50125-43	Res K 6.8 1/4W 5% CC	4.0	R5,6,15,33
50125-44	Res K 10 1/4W 5% CC	1.0	R26
50125-79	Res K 20 1/4W 5% CC	2.0	R11,34
50125-52	Res K 36 1/4W 5% CC	1.0	R2
50125-59	Res K 100 1/4W 5% CC	2.0	R7,13
50125-68	Res K 300 1/4W 5% CC	1.0	R12
50126-01	Res Meg 1 1/4W 5% CC	1.0	R20
50126-10	Res Meg 10 1/4W 5% CC	1.0	R30
50126-09	Res Meg 15 1/4W 5% CC	3.0	R16,17,27
50034-01	Diode 1N4005 Rec 600V 1A	1.0	CR5
50036-01	Diode 1N914B Signal 100V	12.0	CR1-4,6,7,10-12,14-16
50040-01	Diode 1N4742 Zen 12V 1A	1.0	CR13
50044-01	Diode 1N750 Zen 4.7V	2.0	CR8,9
50267-01	Trnstor 2N2222 NPN SS Gen Purp Amp 30VbrCEO TO-18	5.0	Q1-4,8
50209-01	Cap .002 uF 1000V 20% cerm disc lo V	1.0	C31
50209-14	Cap .01 uF 100V 20% cerm disc lo V	15.0	C5,7-12,14,16,17,19,
50209-14	Cap .01 uF 100V 20% cerm disc lo V	0.0	23,25,28,30
50064-01	Cap .1 uF 35VDC 10% tant resin dip	1.0	C21
50066-07	Cap .47 uF 50V 20% mono dip .25 leads	2.0	C22,24
50060-16	Cap .47 uF 50V 10% tant axial	1.0	C13
50064-02	Cap 10 uF 20VDC 10% tant resin dip	1.0	C27
50324-05	Cap 10 uF 25VDC 10% elect axial	4.0	C1-3,6
50064-19	Cap 100 uF 6VDC 10% tant resin dip	1.0	C15
77710-01	NIN Dwg Loc not used See Ref	0.0	R23,29,Q6,7,C4,26,29
REV-G	NIN Rev-G This Assy is at Rev-G	0.0	40A METERS R26 WS7.5K

Rod-L Electronics, Inc. -- Bill Of Materials
 00671-01 Assy Con Recp Hi Voltage Block 3P FP All Units

od-L P/N	Description	qty	Reference	R
0110-08	Asmy Hi Voltage FP Recp Block bakelite mach insert	1.0	HV Recp	00
0230-06	Con Pin Contact Clip W-shape copper HV for HV recp	1.0	HV Pin	00
0290-05	Con Pin Contact Clip U-shape copper Gnd for HVrecp	1.0	Gnd Pin	00
0291-05	Plate Mtg gnd contact 6 holes .8x1.05 copper	1.0	Gnd Plate	00
0513-12	Label 'High Voltage' for HV Recp 2x3 blk w/red/wht	1.0	Label	00
0584-02	Washer Fiber # 4 black HH Smith 2161	4.0	HW	50
0530-02	Screw PanSem Phl 4-40 x .250	1.0	HW Grnd Contact Pin	50
0588-04	Washer Split-Lock # 4	1.0	HW Grnd Contact Pin	50
0202-02	Lug Solder # 4 1 solder hole, 1 internal lock	1.0	HW	50
0202-03	Lug Solder # 6 1 solder hole, 1 internal lock	1.0	HW	50
0530-11	Screw PanSem Phl 4-40 x .312	4.0	HW	50
0536-02	Screw Pan Hd Phl 4-40 x .250	1.0	HW	50
0531-02	Screw PanSem Phl 6-32 x .250	1.0	HW	50
EV-A	NIN Rev-A This Assy is at Rev-A	0.0		R

Rod-L Electronics, Inc. -- Bill Of Materials
00977-02 Assy Switch START Rev B ALL Instruments

Rod-L P/N	Description	qty	Reference
00232-01	Bezel Round alum .990dia (Start Switch)	1.0	
00232-02	Button White Plastic .74dia x.6tall (Start Switch)	1.0	
50555-01	Switch PushButton Momntry SPDT wiringLug C&K 8121Z	1.0	
00232-03	Bezel-Nut Knurled alum 1 15/16 I.D. (Start Switch)	1.0	
REV-B	NIN Rev-B This Assy is at Rev-B	0.0	

Rod-L Electronics, Inc. -- Bill Of Materials
 00333-03 Assy Cable Interface M25 to Hipot 3pHVcon(2ea) 16"

od-L P/N	Description	qty	Reference	Re
0510-01	Asm Kit Con Plug HV cord mtg 4pin Amp 863022-2	2.0	HV Con	50
0508-00	Wire 22AWG insul STC UL1015 color undesignated	1.5	Wiring to Pin 2	50
0508-01	Wire 22AWG insul STC UL1015 brown	0.0	Wiring to Pin 2	50
0709-00	Wire 22AWG insul STC UL1061 PVC color undesignate	3.0	Wiring to Pin 3 & 4	50
0709-09	Wire 22AWG insul STC UL1061 PVC white	0.0	Wiring to Pin 4	50
0709-08	Wire 22AWG insul STC UL1061 PVC grey	0.0	Wiring to Pin 3	50
0773-02	Wire 22AWG 20kV insul STC UL3239 red	1.5	Wiring to Pin 1	50
0715-01	Tube Sleeving .375(3/8)ID blk PVC105 deg Type VW-1	1.0	Tubing	50
7137-02	NIN Tool Chem Adhesive/Sealant RTV 108	0.0	Sealant	7'
7100-02	NIN Tool Chem Cleaner Alcohol Denatured	0.0	Cleaner	7'
7141-01	NIN Tool Chem Potting Compound HYSOL 4215 (100part	0.0	Sealant	7'
7141-02	NIN Tool Chem Potting Compound Hardner (15 part)	0.0	Sealant	7'
EV-A	NIN Rev-A This Assy is at Rev-A	0.0		RI

Rod-L Electronics, Inc. -- Bill Of Materials
 00436-02 Assy Cable Hi Cur Gnd GiantBanaPlug/BatteryClip 4'

Rod-L P/N	Description	qty	Reference
50052-01	Con Clip Battery 3/4"open 3"L 75Amp Mueller 25-C	1.0	Clip
50574-01	Con Insulator Vinyl Boot:Battry Clip Type 25C blk	1.0	Boot
50539-01	Con Plug Banana Giant 2.7"Tot blk HH Smith 285-103	1.0	Banana Plug
50684-01	Wire Braid Tube .25 ID TC 53A Alpha 2171	4.0	Braid
50715-06	Tube Sleeving .25(1/4)ID blk PVC105 deg Type VW-1	4.0	Sleeving
REV-B	NIN Rev-B This Assy is at Rev-B	0.0	

Rod-L Electronics, Inc. -- Bill Of Materials
 00996-01 Assy Harness Plate Front M 25

d-L P/N	Description	qty	Reference	Ro
460-12	Con Mascon HousingRecp 1ro F .100"22gauge 12p Pand'	1.0	FP	50
461-12	Con Cover End .100" Mascon Housing 12p P Panduit	1.0	FP	50
581-01	Tie-Mount Cable Tie .75x.75 w/ Adhesive	2.0	Tie Wrap Mounts	50
399-01	TieWrap CableBundle dia .75 SST1M-M	15.0	Tie Wraps	50
709-00	Wire 22AWG insul STC UL1061 PVC color undesignate	10.0	Wiring	50
V-A	NIN Rev-A This Assy is at Rev-A	0.0		RE

Rod-L Electronics, Inc. -- Bill Of Materials
00997-01 Assy Harness Plate Rear M 25

Rod-L P/N	Description	qty	Reference
00112-05	Assy PCB A 7 Voltage Input Select Switch M25	1.0	A7
50452-01	Con Pin Contact HV F 16-18AWG Blue Stripe Amp	4.0	HV Recp
50670-04	Con Terminal Ring 18-22AWG(red) # 8 lug or stud	10.0	TS, Relay, Grounds
50670-05	Con Terminal Ring 18-22AWG(red) # 6 lug or stud	2.0	Relay
50670-08	Con Terminal Ring 18-22AWG(red) #10 lug or stud	1.0	Banana Jack
50460-12	Con Mascon HousingRecp 1ro F .100"22gauge 12p Pand	1.0	RP
50461-12	Con Cover End .100" Mascon Housing 12p P Panduit	1.0	RP
50581-01	Tie-Mount Cable Tie .75x.75 w/ Adhesive	2.0	Tie Wrap Mounts
50399-01	TieWrap CableBundle dia .75 SST1M-M	15.0	Tie Wraps
50820-05	Tube Shrink 0.25 (1/4) dia	2.0	Wiring
50709-00	Wire 22AWG insul STC UL1061 PVC color undesignate	15.0	Wiring
50773-02	Wire 22AWG 20kV insul STC UL3239 red	3.0	Wiring
REV-A	NIN Rev-A This Assy is at Rev-A	0.0	

Rod-L Electronics, Inc. -- Bill Of Materials
 00998-01 Assy Harness Plate Chassis M 25

Qd-L P/N	Description	qty	Reference	R
0150-07	Res Ohm 100 1/2W 5% CC	1.0	R2 (TS1)	50
0316-19	Res Ohm 400 3W 1% WW	1.0	R1 (TS1)	50
0670-01	Con Terminal Ring 10-12AWG(yel) # 6 lug or stud	4.0	Relays	50
0670-05	Con Terminal Ring 18-22AWG(red) # 6 lug or stud	7.0	Relays	50
0670-07	Con Terminal Ring 10-12AWG(y1) # 8 lug orStud thin	3.0	TS,Grnds	50
0670-04	Con Terminal Ring 18-22AWG(red) # 8 lug or stud	7.0	TS,Grnds	50
0670-06	Con Terminal Ring 10-12AWG(y1) #10 lug orStud thin	1.0	FP	50
0230-01	Jumper Barrier Strip Over Slide-inSlot 140J-1	6.0	Relays	50
0230-03	Jumper Barrier Strip Around Flat w/Screw hole	12.0	Relays	50
0460-08	Con Mascon HousingRecp 1ro F .100"22gauge 8p Pand	2.0	Conn	50
0461-08	Con Cover End .100" Mascon Housing 8p P Panduit	2.0	Conn	50
0581-01	Tie-Mount Cable Tie .75x.75 w/ Adhesive	1.0	Tie Wrap Mounts	50
0399-01	TieWrap CableBundle dia .75 SST1M-M	15.0	Tie Wraps	50
0697-09	Wire 12AWG insul BTC TypeTHHN E-123443-X600V white	3.0	Wiring	50
0709-00	Wire 22AWG insul STC UL1061 PVC color undesignate	15.0	Wiring	50
0773-02	Wire 22AWG 20kv insul STC UL3239 red	3.0	Wiring	50
0698-00	Wire 18AWG insul STC ULAWM E-11755 color undesgnt	3.0	Wiring	50
EV-A	NIN Rev-A This Assy is at Rev-A	0.0		RI

Rod-L Electronics, Inc. -- Bill Of Materials
00112-05 Assy PCB A 7 Voltage Input Select Switch M25

Rod-L P/N	Description	qty	Reference
00111-05	PCB Fab A 7 AC Voltage Input Select Switch (RevD)	1.0	A7 PCB Fab
50286-01	Varistor 10 Joules GE VA130LA10A	2.0	V1,2
REV-D	NIN Rev-D This Assy is at Rev-D	0.0	

Rod-L Electronics, Inc. -- Bill Of Materials
 00801-02 Opt 01C Remote Control Digital GT

od-L P/N	Description	qty	Reference	Re
1170-13	Assy Kit Ship Option 01 Remote Accessories	1.0	Ship Kit	0:
0949-01	Assy PCB A26 Mother GT Ground Tester	1.0	A26 PCB Assy OUT	0:
0949-02	Assy PCB A26 Mother GT Ground Tester w/ Remote	1.0	A26 PCB Assy IN	0:
1208-15	Assy PCB A 8 Opt 19, PasSig, no AuRes GT Rev D	1.0	A8 PCB Assy RevB,C ok	0:
1010-03	Assy Cable&Cons: FRC DB25S pemnut, Mascn 26p2ro 12"	1.0	Cable Assy PCB to RP	0:
0185-01	Asm Kit Con HW JackSocket Screw hex4-40 5/16L& HW	1.0	HW	5:
EV-A	NIN Rev-A This Assy is at Rev-A	0.0		RI

Rod-L Electronics, Inc. -- Bill Of Materials
01170-13 Assy Kit Ship Option 01 Remote Accessories

Rod-L P/N	Description	qty	Reference
50301-01	Asm Kit Con-Cover Cutout DB25 black plastic	1.0	Remote cover
50305-03	Cover Hole Plug .25" dia blk plastic HH Smith3089	1.0	Remote swtch covr ACs
50403-01	Con D Sub Min M 25p pnl mtg Solder DB25P	1.0	25P Con
50263-01	Asm Kit Con HW & Shell for DB25 DB51226-1A	1.0	Shell & HW

Rod-L Electronics, Inc. -- Bill Of Materials
 01010-03 Assy Cable&Cons: FRC DB25S pemnut,Mascn 26p2ro 12"

od-L P/N	Description	qty	Reference	R
0418-01	Con Mascon 2ro F 26p FRC Term 3M 3399-6026(6326)	1.0	26p con	5
0430-02	Con D Sub Min F 25p FRC Term Threaded pnl mtg	1.0	DB25S con	5
0185-04	Asm Kit Con HW JackSocket Screw hex4-40 3/8L & HW	2.0	HW DB25S con	5
0253-26	Cable Ribbon 26 conductr 28 AWG	1.0	Ribbon Cable	5
EV-A	NIN Rev-A This Assy is at Rev-A	0.0		R

Rod-L Electronics, Inc. -- Bill Of Materials
01049-01 Assy Cable&Cons& Local/Remote Switch (12pin)

Rod-L P/N	Description	qty	Reference
50564-01	Switch Toggle 4PDT Wire Lugs Alco MTE 406N	1.0	Switch
REV-A	NIN Rev-A This Assy is at Rev-A	0.0	

Rod-L Electronics, Inc. -- Bill Of Materials
 01208-15 Assy PCB A 8 Opt 19, PasSig, no AuRes GT Rev D

od-L P/N	Description	qty	Reference	R
1210-04	NIN Schem PCB A 8 Opt 01 or 19, PasSig RevD GT,AC	0.0	Reference	0
1209-04	PCB Fab A 8 Opt 01 or 19, PasSig, no AuRes RevD GT,AV	1.0	A8 PCB Fab	0
0264-06	IC-Socket 6p Lo Profile .3 DIP	8.0	X1,2,6-8,11,12,13	5
0264-14	IC-Socket 14p Lo Profile .3 DIP	4.0	X3,5,9,10	5
0264-16	IC-Socket 16p Lo Profile .3 DIP	1.0	X4	5
0079-01	IC Optical Coupler H11B1	8.0	U1,2,6-8,11,12,13	5
0149-03	IC AND 2-in Lo pwr Schotky quad 74LS08	1.0	U3	5
0155-03	IC FF Lo Pwr Schotky quad 74LS175	1.0	U4	5
0095-01	IC Inverter/Driver OC hex 7416N	1.0	U5	5
0128-01	IC Op Amp Lo Power quad LM324	1.0	U9	5
0103-01	IC Op Amp dual UA747	1.0	U10	5
0702-07	Pot K 10 20 turns offset pins rectangle	1.0	R23	5
0702-09	Pot K 25 20 turns offset pins rectangle	2.0	R24,25	5
0702-10	Pot K 50 20 turns offset pins rectangle	2.0	R21,22	5
0125-21	Res Ohm 330 1/4W 5% CC	4.0	R14,16-18	5
0125-31	Res K 1 1/4W 5% CC	2.0	R13,26	5
0125-35	Res K 2 1/4W 5% CC	4.0	R11,12,19,27	5
0125-36	Res K 2.2 1/4W 5% CC	1.0	R20	5
0125-41	Res K 5.1 1/4W 5% CC	1.0	R15	5
0125-44	Res K 10 1/4W 5% CC	7.0	R1-7	5
0125-59	Res K 100 1/4W 5% CC	4.0	R8-10,28	5
0267-01	Trnstor 2N2222 NPN SS Gen Purp Amp 30VbrCEO TO-18	1.0	Q1	5
0209-14	Cap .01 uF 100V 20% cerm disc lo V	6.0	C5-9,11	5
0324-05	Cap 10 uF 25VDC 10% elect axial	4.0	C1-3,10	5
0321-09	Cap 47 uF 25V elect radial	1.0	C4	5
0614-26	Con HeaderStrip 2ro .100"C/C .025"sq 26p M PCBmnt	1.0	J1	5
REV-A	NIN Rev-A This Assy is at Rev-A	0.0		R

Rod-L Electronics, Inc. -- Bill Of Materials
 00975-07 Assy PCB A 8 Opt 01 RevD IBMLEX

Rod-L P/N	Description	qty	Reference
00980-07	NIN Schem PCB A 8 Opt 01 RevF AV/BV IBM OPT	0.0	Reference
00324-03	PCB Fab A 8 Opt 01, AutoRes RevD IBMLEX	1.0	A8 PCB Fab
50264-06	IC-Socket 6p Lo Profile .3 DIP	6.0	X2,3,6-9
50089-01	IC Optical Coupler MCT2E (Motorola only)	6.0	U2,3,6-9
50125-13	Res Ohm 220 1/4W 5% CC	6.0	R1-6
50125-31	Res K 1 1/4W 5% CC	1.0	R7
50125-36	Res K 2.2 1/4W 5% CC	4.0	R8-11
50324-05	Cap 10 uF 25VDC 10% elect axial	2.0	C1,2
50272-01	Trnstor 2N3904 NPN SS Gen Purp RF 40VbrCEO TO-92	1.0	Q1
50817-02	Jumper Wire #22 AWG .2" long	2.0	Jumpers
50571-01	Relay 5VDC DPDT 1a 8pin 1495SSDC	1.0	K1
REV-D	NIN Rev-D This Assy is at Rev-D	0.0	

Rod-L Electronics, Inc. -- Bill Of Materials
 00806-04 Opt 06C Cover Lock-Out Rear Panel GT

od-L P/N	Description	qty	Reference	R
1143-01	Cover Protective Rear Panel Clear GT/AV w/ Opt 01	1.0	Cover	0.
0669-03	Standoff 6-32 x1.50 x.25 OD FF rnd alum	4.0	HW	50
0531-03	Screw PanSem Phl 6-32 x .375	8.0	HW	50
EV-A	NIN Rev-A This Assy is at Rev-A	0.0		R

Rod-L Electronics, Inc. -- Bill Of Materials
00807-02 Opt 07B extra HV Con and Opt 14 w/ GT Start

Rod-L P/N	Description	qty	Reference
50509-01	Con Recp 4p Cylind HV Housing PnlMtg blk plst Amp	1.0	HV con
50451-01	Con Nut 1" for HV Con blk plastic	1.0	HV con
50452-01	Con Pin Contact HV F 16-18AWG Blue Stripe Amp	4.0	HV con

Rod-L Electronics, Inc. -- Bill Of Materials
 00810-01 Opt 10 Audible Testing Tone Beep Gnd Tester

od-L P/N	Description	qty	Reference	R
0972-01	Assy PCB A22 Control Logic GT	1.0	A22 PCB Assy OUT	0
0972-02	Assy PCB A22 Control Logic GT w/Opt10 Aud TestTone	1.0	A22 PCB Assy IN	0
0031-01	Diode 1N4001 Rec 50V 1A	1.0	On Mother PCB	5
EV-A	NIN Rev-A This Assy is at Rev-A	0.0		R

Rod-L Electronics, Inc. -- Bill Of Materials
00972-02 Assy PCB A22 Control Logic GT w/Opt10 Aud TestTone

Rod-L P/N	Description	qty	Reference
00984-01	NIN Schem PCB A22 Control Logic	0.0	Reference
00973-01	PCB Fab A22 Control Logic	1.0	A22 PCB Fab
50128-01	IC Op Amp Lo Power quad LM324	2.0	U4,9
50077-01	IC Switch Bilateral CMOS quad CD4066B	1.0	U3
50092-01	IC Timer dual NE556	1.0	U12
50093-01	IC Timer quad NE558	1.0	U11
50135-01	IC NAND 2-In quad 7400	2.0	U5,6
50142-01	IC NAND 4-In dual 7420	1.0	U10
50167-01	IC Driver Peripheral dual 75452	2.0	U7,8
50079-01	IC Optical Coupler H11B1	2.0	U1,2
50264-06	IC-Socket 6p Lo Profile .3 DIP	2.0	X1,2
50264-08	IC-Socket 8p Lo Profile .3 DIP	2.0	X7,8
50264-14	IC-Socket 14p Lo Profile .3 DIP	7.0	X3-6,9,10,12
50264-16	IC-Socket 16p Lo Profile .3 DIP	1.0	X11
50337-01	ResPak SIP K 2.2 8p 4r 1%	1.0	RP1
50338-02	ResPak SIP K 3 8p 4r 1%	1.0	RP8
50335-02	ResPak SIP K 4.7 8p 4r 1%	2.0	RP2,6
50335-01	ResPak SIP K 10 8p 4r 1%	3.0	RP4,9,10
50338-03	ResPak SIP K 20 8p 4r 1%	1.0	RP5
50338-01	ResPak SIP K 22 8p 4r 1%	1.0	RP7
50339-01	ResPak SIP K 47 8p 4r 1%	1.0	RP3
50702-07	Pot K 10 20 turns offset pins rectangle	2.0	R21,25
50708-01	Pot K 500 20 turns offset pins rectangle	1.0	R24
50702-12	Pot Meg 1 20 turns offset pins rectangle	1.0	R22
50125-08	Res Ohm 100 1/4W 5% CC	1.0	R10
50125-15	Res Ohm 470 1/4W 5% CC	1.0	R1
50125-31	Res K 1 1/4W 5% CC	2.0	R4,14
50125-32	Res K 1.2 1/4W 5% CC	1.0	R3
50125-40	Res K 4.7 1/4W 5% CC	5.0	R8,9,28,31,32
50125-43	Res K 6.8 1/4W 5% CC	4.0	R5,6,15,33
50125-44	Res K 10 1/4W 5% CC	1.0	R26
50125-79	Res K 20 1/4W 5% CC	2.0	R11,34
50125-52	Res K 36 1/4W 5% CC	1.0	R2
50125-53	Res K 47 1/4W 5% CC	2.0	R18,19
50125-59	Res K 100 1/4W 5% CC	2.0	R7,13
50125-68	Res K 300 1/4W 5% CC	1.0	R12
50126-01	Res Meg 1 1/4W 5% CC	1.0	R20
50126-10	Res Meg 10 1/4W 5% CC	1.0	R30
50126-09	Res Meg 15 1/4W 5% CC	3.0	R16,17,27
50034-01	Diode 1N4005 Rec 600V 1A	1.0	CR5
50036-01	Diode 1N914B Signal 100V	12.0	CR1-4,6,7,10-12,14-16
50040-01	Diode 1N4742 Zen 12V 1A	1.0	CR13
50044-01	Diode 1N750 Zen 4.7V	2.0	CR8,9
50267-01	Trnstor 2N2222 NPN SS Gen Purp Amp 30VbrCEO TO-18	6.0	Q1-5,8
50209-14	Cap .01 uF 100V 20% cerm disc lo V	17.0	C5,7-12,14,16,17,19,
50209-14	Cap .01 uF 100V 20% cerm disc lo V	0.0	20,23,25,28,30,31
50064-01	Cap .1 uF 35VDC 10% tant resin dip	1.0	C21
50066-07	Cap .47 uF 50V 20% mono dip .25 leads	2.0	C22,24
50060-16	Cap .47 uF 50V 10% tant axial	1.0	C13
50060-01	Cap 1 uF 35V 10% tant axial	1.0	C18
50064-02	Cap 10 uF 20VDC 10% tant resin dip	1.0	C27
50324-05	Cap 10 uF 25VDC 10% elect axial	4.0	C1-3,6
50064-19	Cap 100 uF 6VDC 10% tant resin dip	1.0	C15
50151-01	Pin-Micro Test .070dia .3/.062 ID x.145 gold	8.0	TP1-8
77710-01	NIN Dwg Loc not used See Ref	0.0	R23,29,Q6,7,C4,26,29
REV-G	NIN Rev-G This Assy is at Rev-G	0.0	40A METERS R26 WS7.5K

Rod-L Electronics, Inc. -- Bill Of Materials
 00814-02 Opt 14 Pin Assignment Spcl with Opt 07 con for GT

od-L P/N	Description	qty	Reference	R
1058-02	NIN Diag Wire Unit M 25 Amp GT 2HV Out & BP	0.0	Reference	0
0673-01	Assy Plate Rear M 25	1.0	RP Assy OUT	0
0673-02	Assy Plate Rear M 25 w/ xtr HV con	1.0	RP Assy IN	0

Rod-L Electronics, Inc. -- Bill Of Materials
00815-01 Opt 15 Kit 19" Rack Mount 5.2"tall A,B,G,D,R,I,J

Rod-L P/N	Description	qty	Reference
00511-05	Bracket Rack Mtg Right 1.32x5.2 Tall MintGrey	1.0	Right Bracket
00512-05	Bracket Rack Mtg Left 1.32x5.2 Tall MintGrey	1.0	Left Bracket
50532-04	Screw PanSem Phl 8-32 x .500	4.0	HW

Rod-L Electronics, Inc. -- Bill Of Materials
 00824-02 Opt 24A Blank Front Panel Receptacle Only

od-L P/N	Description	qty	Reference	R
0671-01	Assy Con Recp Hi Voltage Block 3P FP All Units	1.0-Recp	OUT	0
1138-02	Plate Cover FP HV Recp 4screws.7L 2.8x3.8" MintGry	1.0 Recp	replacement	0
0544-02	Nut Kep 6-32 x .312 (5/16) O.D.	4.0 HW		5
0531-04	Screw PanSem Phl 6-32 x .500	4.0 HW		5
EV-A	NIN Rev-A This Assy is at Rev-A	0.0		R

Rod-L Electronics, Inc. -- Bill Of Materials
00824-03 Opt 24B Blank Front Panel Start Switch Only

Rod-L P/N	Description	qty	Reference
00977-01	Assy Switch START Rev A ALL Instruments	1.0	Start Switch OUT
50298-01	Cover Hole Plug 1" Hole metal 12 prong HH S 612	1.0	Start Switch replace
REV-A	NIN Rev-A This Assy is at Rev-A	0.0	

Rod-L Electronics, Inc. -- Bill Of Materials
 00703-01 Mdl M 30 30 Amp 0.15 Ohm Ground Tester

Mod-L P/N	Description	qty	Reference	R
0878-01	Assy Unit M 30 Tested Ground Tester	1.0	Unit	0
1163-01	Assy Kit Covers @ ButtonUp 5"H units <ND>	1.0	ButtonUp	0
1170-02	Assy Kit Ship M 25 Box w/ Accessories	1.0	Shipping	0
EV-A	NIN Rev-A This Assy is at Rev-A	0.0		R

Rod-L Electronics, Inc. -- Bill Of Materials
00703-02 Mdl M 25L (30) Amp 0.3 Ohm GT for use with M450LT

Rod-L P/N	Description	qty	Reference
00701-01	Mdl M 25 25 Amp 0.15 Ohm Ground Tester	1.0	M25
01445-01	Opt X53 Upgrade GT to M25L interface with the M450	1.0	Opt X53

Rod-L Electronics, Inc. -- Bill Of Materials
 00703-03 Mdl M 30L (35) Amp 0.3 Ohm GT for use with M450LT

Mod-L P/N	Description	qty	Reference	R
0701-01	Mdl M 25 25 Amp 0.15 Ohm Ground Tester	1.0	M25	0
1445-01	Opt X53 Upgrade GT to M25L interface with the M450	1.0	Opt X53	0

Rod-L Electronics, Inc. -- Bill Of Materials
00704-01 Mdl M 40 40 Amp 0.15 Ohm Ground Tester

Rod-L P/N	Description	qty	Reference
00880-01	Assy Unit M 40 Tested Ground Tester	1.0	Unit
01163-01	Assy Kit Covers @ ButtonUp 5"H units <ND>	1.0	ButtonUp
01170-02	Assy Kit Ship M 25 Box w/ Accessories	1.0	Shipping
REV-A	NIN Rev-A This Assy is at Rev-A	0.0	

Rod-L Electronics, Inc. -- Bill Of Materials
 00705-01 Mdl IBMLEX4 M 25 (Amp) 0.15 Ohm GT w/ Op1,6,15,24B

od-L P/N	Description	qty	Reference	R
0701-01	Mdl M 25 25 Amp 0.15 Ohm Ground Tester	1.0	M25	0
0801-02	Opt 01C Remote Control Digital GT	1.0	Opt 01C	0
0806-04	Opt 06C Cover Lock-Out Rear Panel GT	1.0	Opt 06C	0
0815-01	Opt 15 Kit 19" Rack Mount 5.2"tall A,B,G,D,R,I,J	1.0	Opt 15A	0
			1.0 18AWG wire on Fuses	
0824-03	Opt 24B Blank Front Panel Start Switch Only	1.0	Opt 24B	0

Rod-L Electronics, Inc. -- Bill Of Materials
 00705-02 Mdl M 25LEXMARK GT w/ Opt 01C,StartSwitch disabled

Rod-L P/N	Description	qty	Reference
00701-01	Mdl M 25 25 Amp 0.15 Ohm Ground Tester	1.0	M25
00801-02	Opt 01C Remote Control Digital GT	1.0	Opt 01C
50527-01	Con Post Binding/StdBanaJack blk .94"base.875"L#10	1.0	Std Chs Grnd Ban jack
		1.0	Start switch disabled
00436-02	Assy Cable Hi Cur Gnd GiantBanaPlug/BatteryClip 4'	1.0	Ground Cable out
00436-03	Assy Cable Hi Cur Gnd GiantBanaPlug/BatteryClip 6'	1.0	Ground Cable in

Rod-L Electronics, Inc. -- Bill Of Materials
 00706-01 Mdl M 35 35 Amp 0.15 Ohm Ground Tester

od-L P/N	Description	qty	Reference	R
0880-02	Assy Unit M 35 Tested Ground Tester	1.0	Unit	0
1163-01	Assy Kit Covers @ ButtonUp 5"H units <ND>	1.0	ButtonUp	0
1170-02	Assy Kit Ship M 25 Box w/ Accessories	1.0	Shipping	0
EV-A	NIN Rev-A This Assy is at Rev-A	0.0		R

REV	DESCRIPTION	DATE	APPROVED
D	REPLACED PINS 00491-02 REV. C	6-4-86	Phassy



— STAMP PART NUMBER HERE

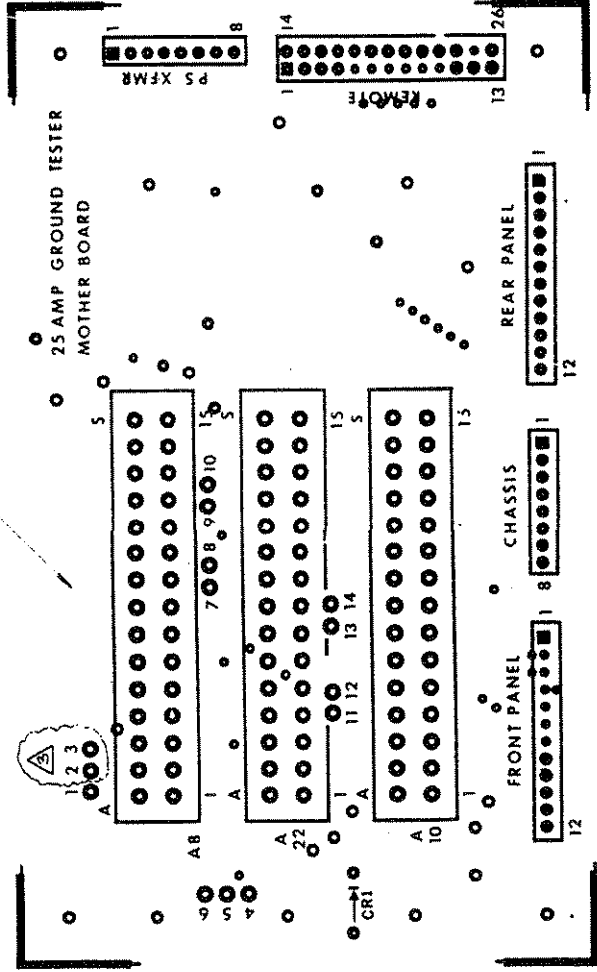

TABULATION BLOCK	
DASH#	DESCRIPTION
-01	GROUND TESTER
-02	4HD TESTER W/ REMOTE

- NOTES:
- REFERENCE WIRING INTERCONNECTION DIAGRAM DRAWING #00974-01
 - SEE SEPARATE PARTS LIST
 - FOR -01 (W/OUT AB REMOTE), JUMPER BETWEEN 2 & 3
 - FOR CRI USE JUMPER EXCEPT WHEN AUDIBLE TEST TONE OPTION IS PRESENT USE IN4002.

DATE	APPROVED	REVISION	DESCRIPTION
JUN 4-85			
COMMENTS		SCALE	SHEET
ASSEMBLY PCB A26		2X	1 OF 1
MOTHER BOARD			
SIZE	FRONT VIEW	DWG. NO.	REV.
C		00949-XX	D
DO NOT SCALE DRAWING			

REV. NO.	REV. DATE	REV. BY
1	5-21-86	W. Jolley
REDESIGNED FROM DINA NO. 00451-01 REV. C		

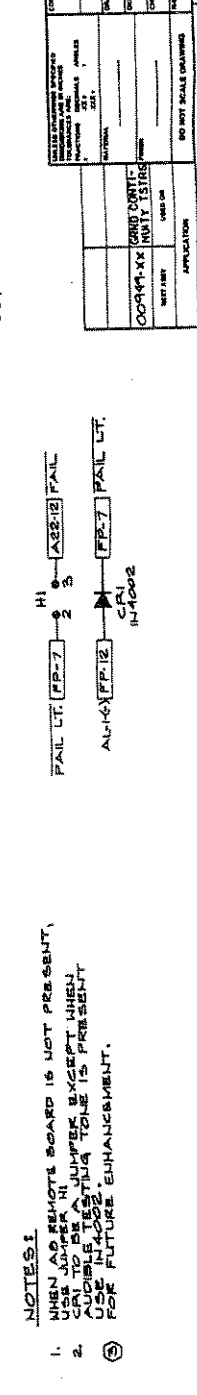
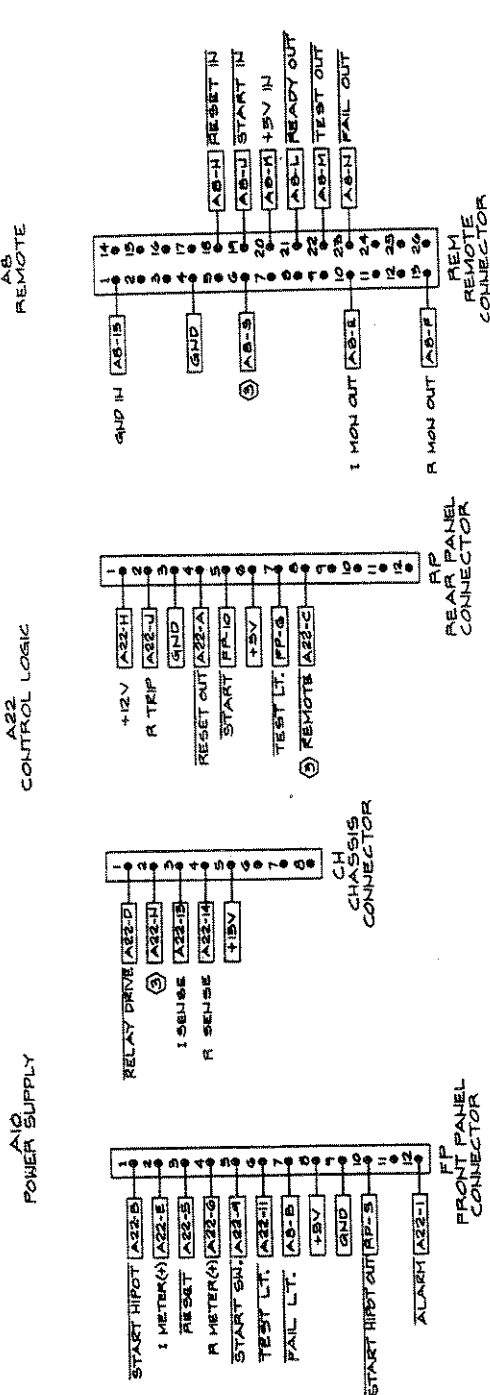
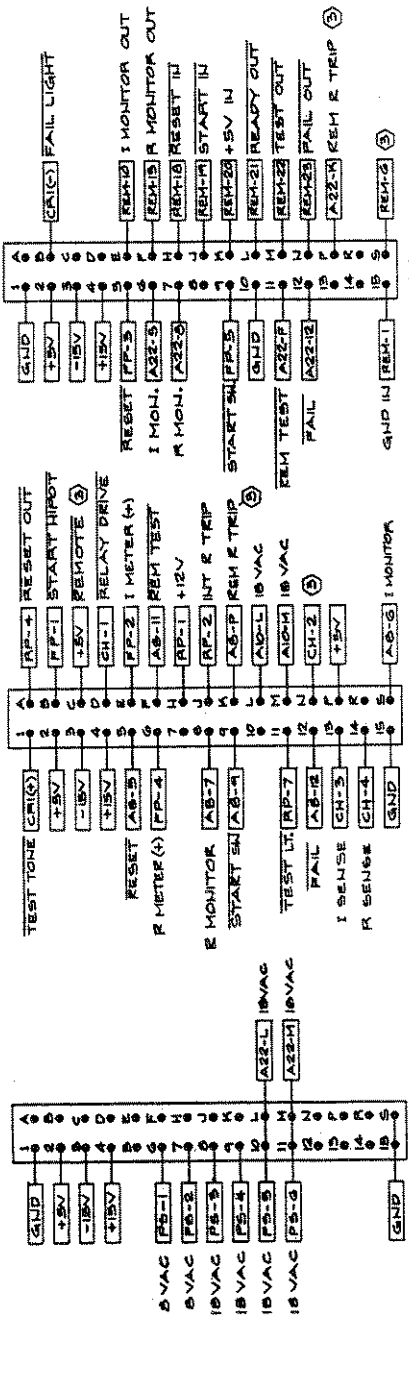

- NOTES:
1. WHEN AB REMOTE BOARD IS NOT PRESENT, USE JUMPER H1 UNLESS EXCEPT WHEN AUDIO BEeping TONE IS PRESENT
 2. AUDIO BEeping TONE IS PRESENT USE IN A22-12 FOR FUTURE ENHANCEMENT.

CONTRACT NO.	DATE	REV.	REV. DATE
00999-XX	JUN 3-86	D	00974-01
DESCRIPTION	TESTER	REV. DATE	REV. DATE
GROUND CONTINITY TESTER			
WIRING A26 MOTHER PCB			

APPROVALS	DATE	REV.	REV. DATE
	JUN 3-86	D	00974-01
DESCRIPTION	TESTER	REV. DATE	REV. DATE
GROUND CONTINITY TESTER			
WIRING A26 MOTHER PCB			

DO NOT SCALE DRAWING	SCALE	REV. DATE	REV. DATE

DIAGRAM INTERCONNECTION	REV. DATE	REV. DATE
GROUND CONTINITY TESTER		
WIRING A26 MOTHER PCB		

REV	DESCRIPTION	DATE	BY
A	CHANGED PARTS CALL OUT	6-84	BILL

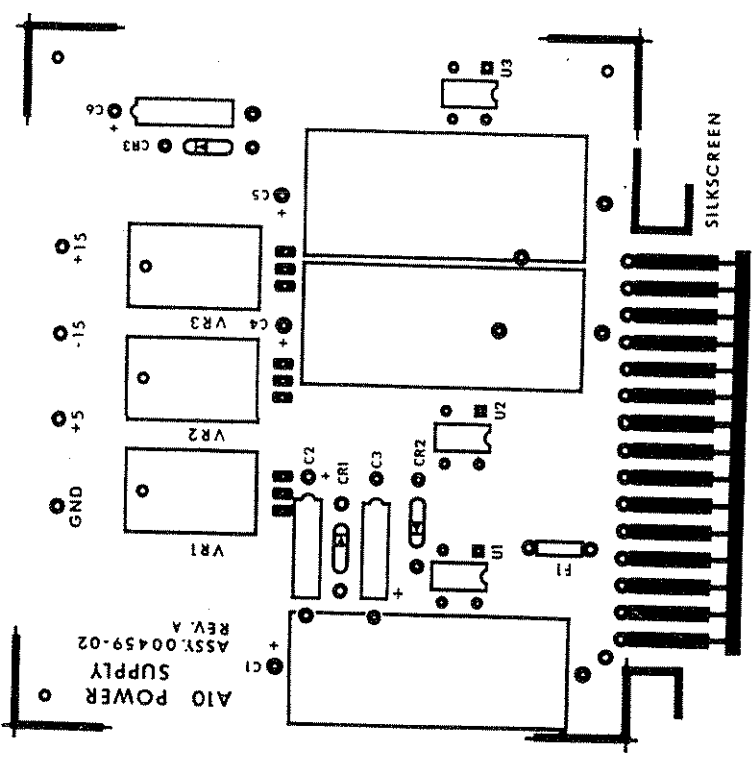

A10 POWER
SUPPLY
ASSY: 00459-02
REV. A

PADMASTER

SILKSCREEN

- NOTES:**
1. REFERENCE SCHEMATIC DRAWING NO. 20978-01
 2. SEE SEPARATE PARTS LIST.

DWG. NO.		REV.	DATE
PARTS LIST		APPROVED	DATE
ROD-I ELECTRONICS, INC.		CHECKED	DATE
ASSEMBLY PCB		DATE	DATE
POWER SUPPLY BOARD		DATE	DATE
DWG. NO. 00459-02		SHEET 2X OF 1	

APPROVED	DATE
CHECKED	DATE
DATE	DATE
DATE	DATE

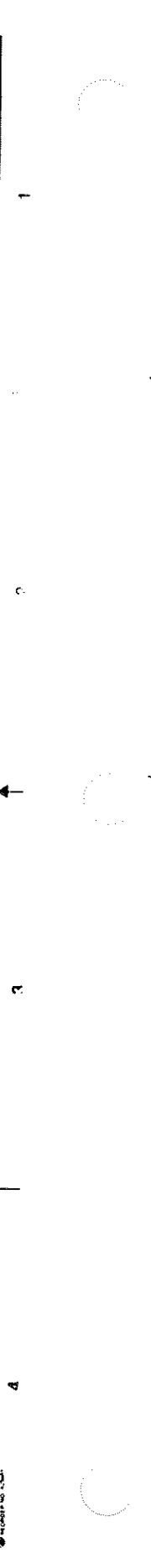

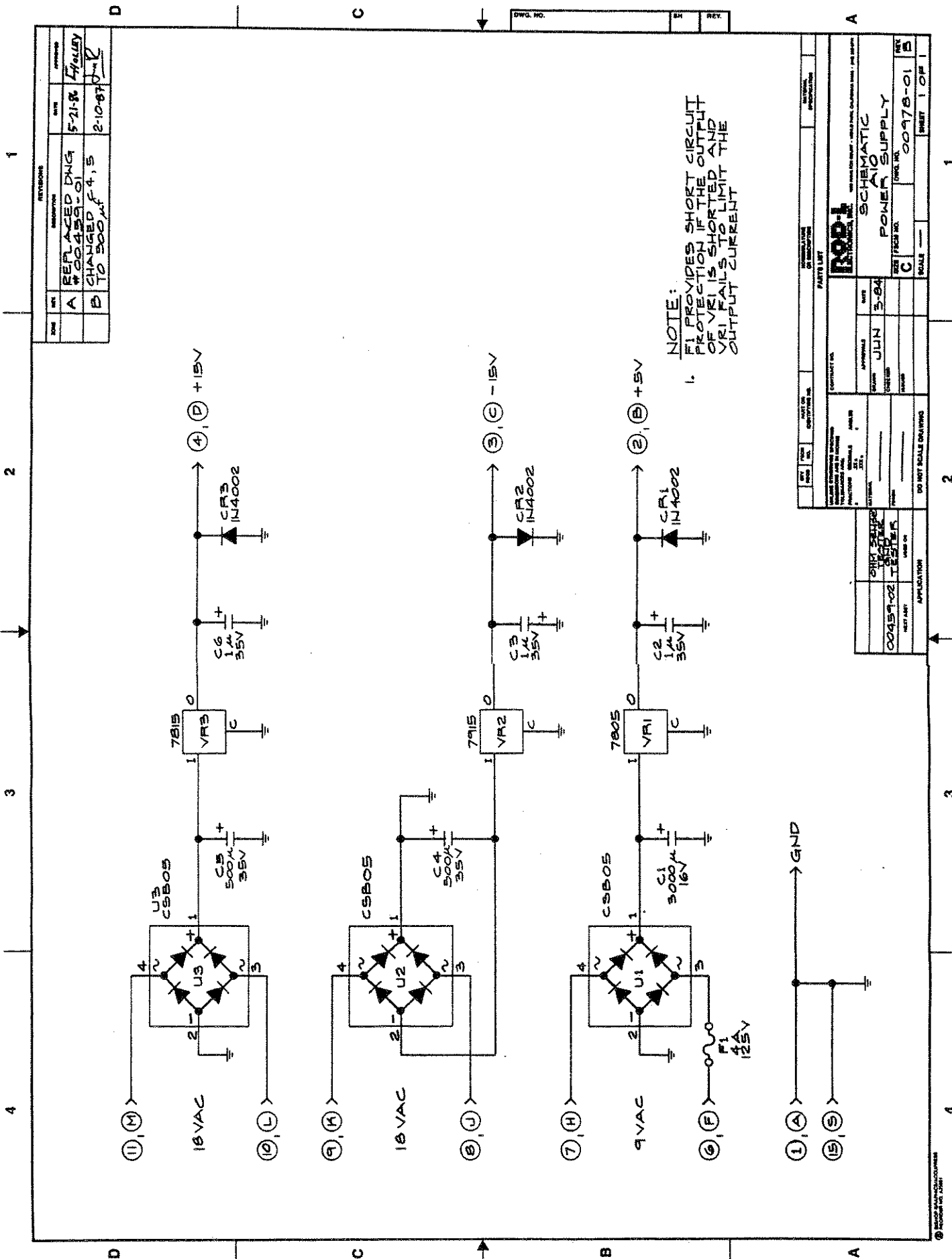

REV	DESCRIPTION	DATE	BY
A	REPLACED DWG #00459-01	5-21-88	Haley
B	CHANGED F 4, 5 TO 500µF	2-10-87	DK

REV	DESCRIPTION	DATE	BY
A	REPLACED DWG #00459-01	5-21-88	Haley
B	CHANGED F 4, 5 TO 500µF	2-10-87	DK

REV	DESCRIPTION	DATE	BY
A	REPLACED DWG #00459-01	5-21-88	Haley
B	CHANGED F 4, 5 TO 500µF	2-10-87	DK

REV	DESCRIPTION	DATE	BY
A	REPLACED DWG #00459-01	5-21-88	Haley
B	CHANGED F 4, 5 TO 500µF	2-10-87	DK

1 2 3 4

REV	DATE	DESCRIPTION	BY	APPROVE
G	6-4-86	CHANGE DRAWING 00448-02 REV. C ADDED TAB BLOCK		Holley

AMMETER ADJ
TEST TIME ADJ
OHMMETER ADJ

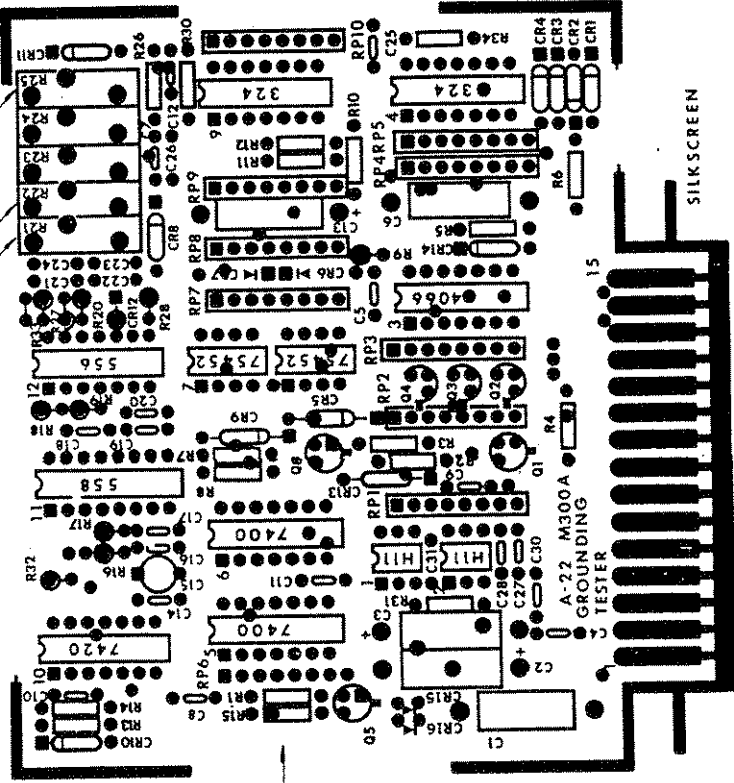

TABULATION BLOCK	
DASH#	DESCRIPTION
-01	CONTROL LOGIC
-02	CTRL LGC N/TEST TONE

- NOTES:
1. REFERENCE SCHEMATIC DRAWING # 00484-XX
 2. SEE SEPARATE PARTS LIST

PARTS LIST	
DATE	1-85
APPROVALS	
DESIGNED BY	
CHECKED	
DRAWN	
SCALE	2:X
SHEET 1 OF 1	

ROD-I ELECTRONICS, INC.	
CONTROL #	ASSEMBLY PCB#
DATE	ASSEMBLY PCB#
JUN 1-85	A22
CHECKER	CONTROL LOGIC BOARD
DRAWN	DWG NO. 00972-XX
SCALE	2:X
SHEET 1 OF 1	

1
2
3
4

REV	DATE	BY	APPROVED
1	5-18-81	PH	PH
REDESIGN, REPLACED DRUG			
00446-01 REV F			
G ADDED TAB BLOCK			

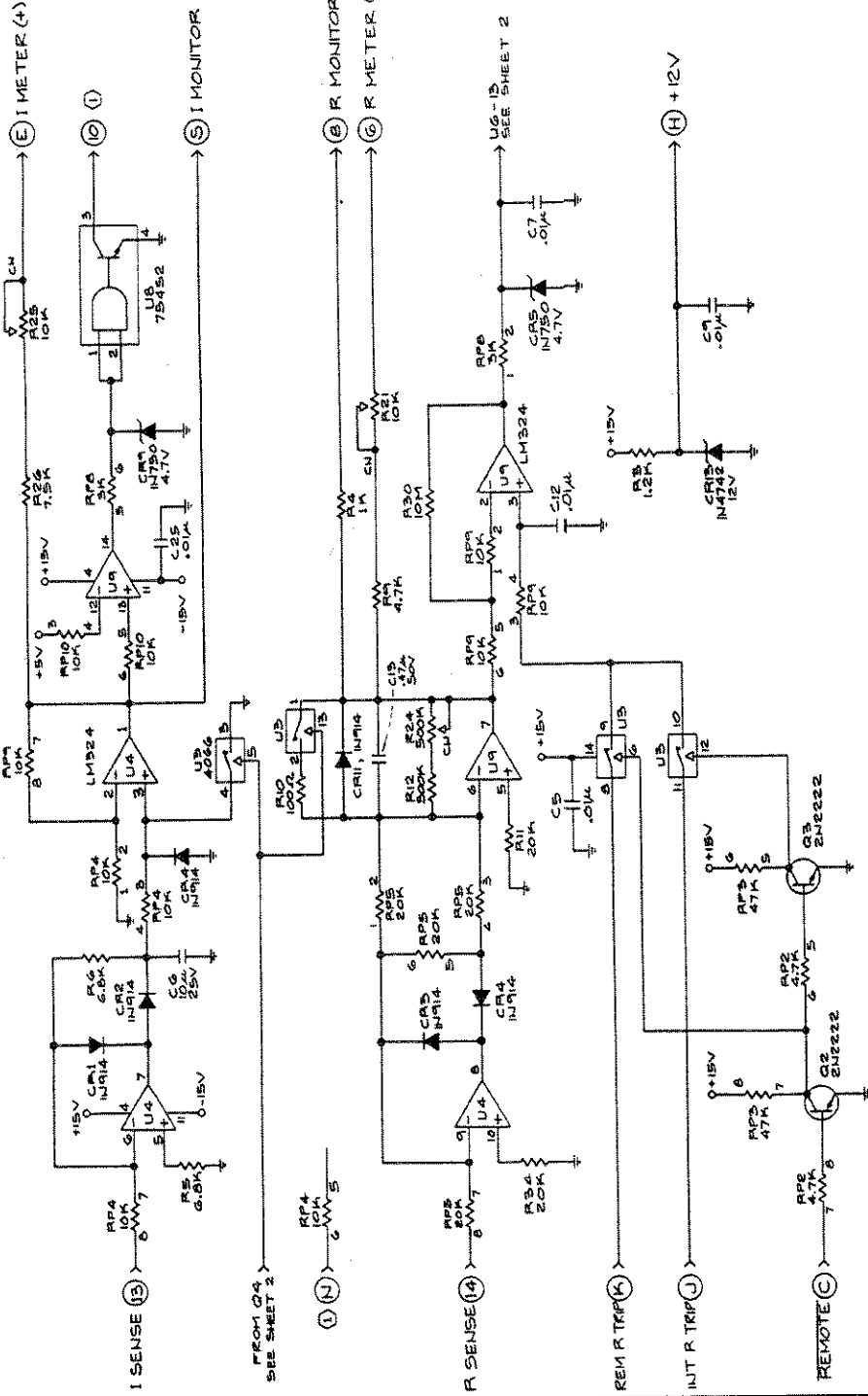

NOTES
 (1) FOR FUTURE ENHANCEMENTS

CONTRACT NO.		DATE	
APPROVALS		JUL 8-86	
DESIGNER		CHECKED	
DRAWN		SCALE	
REVISIONS		DO NOT SCALE DRAWING	
PROJECT NO.		SHEET 1 OF 2	
TESTER		CORP 4-XX	
APPLICATOR		G	

SHEETS		SHEET 1 OF 2	
TITLE		SCHEMATIC	
SUB-TITLE		CONTROL LOGIC	
PART NO.		CORP 4-XX	
SCALE		G	

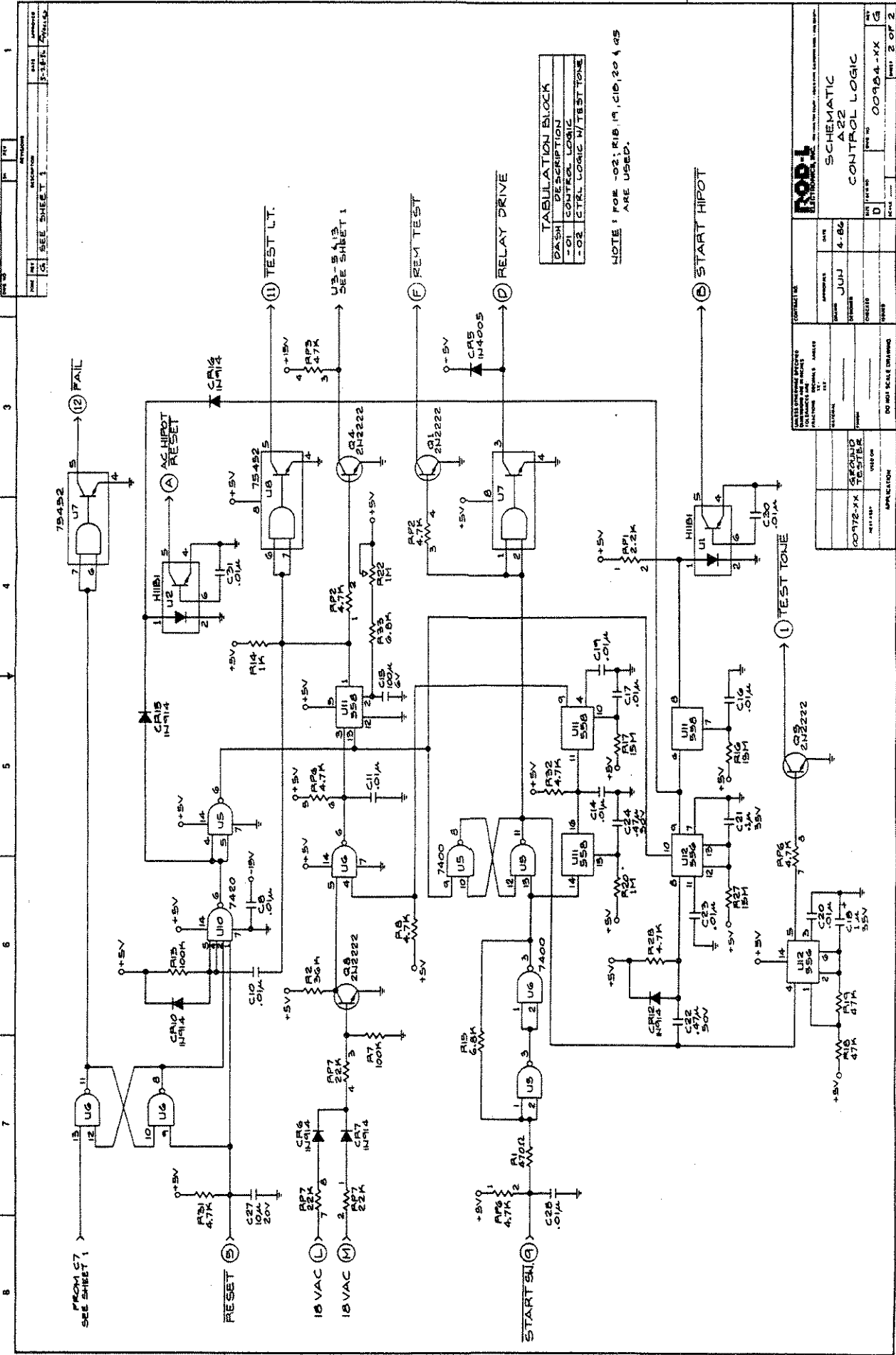

TABULATION BLOCK
DASH DESCRIPTION
-01 CTRL LOGIC
-02 CTRL LOGIC W/ TEST TONE

NOTE: FOR -02; R18, R19, C16, R20 & R25 ARE USED.

NO. 1
 CONTROL LOGIC
 A22

DATE	4-86
DESIGNED BY	JUHJ
CHECKED BY	
OPERATION	
DO NOT SCALE DRAWING	

CONTRACT NO.	
PROJECT NO.	
REV.	
DATE	
BY	
CHKD BY	
APP'D BY	
SCALE	

REV.	00904-KX
DATE	4-86
BY	JUHJ
CHKD BY	
APP'D BY	
SCALE	

REV.	00904-KX
DATE	4-86
BY	JUHJ
CHKD BY	
APP'D BY	
SCALE	

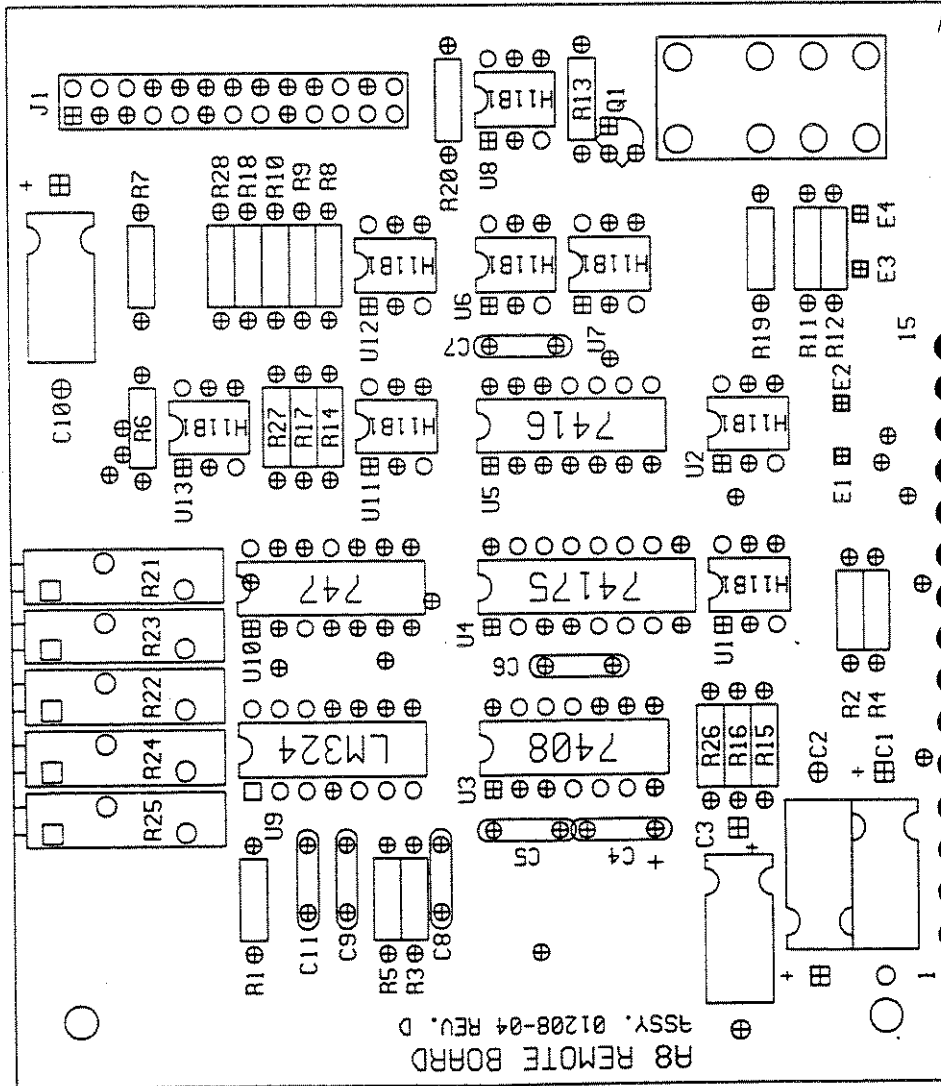

TABULATION BLOCK

DASH #	DESCRIPTION
01208-15	OPT.19, PASS SIGNAL, NO AUTO RESET, FOR GT
01208-16	OPT.01, PASS SIGNAL, NO AUTO RESET, FOR AV
01208-17	OPT.01, PASS SIGNAL, NO AUTO RESET, FOR GT

CONTRACT NO. UNLESS OTHERWISE SPECIFIED DIMENSIONS ARE IN INCHES TOLERANCES ARE: FRACTIONS DECIMALS ANGLES XXX .005 1°		ROD-L ELECTRONICS, INC. 923 HAMILTON AVE. HENLO PARK, CALIFORNIA 94025 (415) 322-8711	
APPROVALS DRAWN CHECKED ISSUED	DATE 11-15-91	SIZE D	QWG. NO. 01208-XX
ASSEMBLY DRAWING A8 REMOTE CONTROL OPTION 01		SCALE NTS	SHEET 1 OF 1

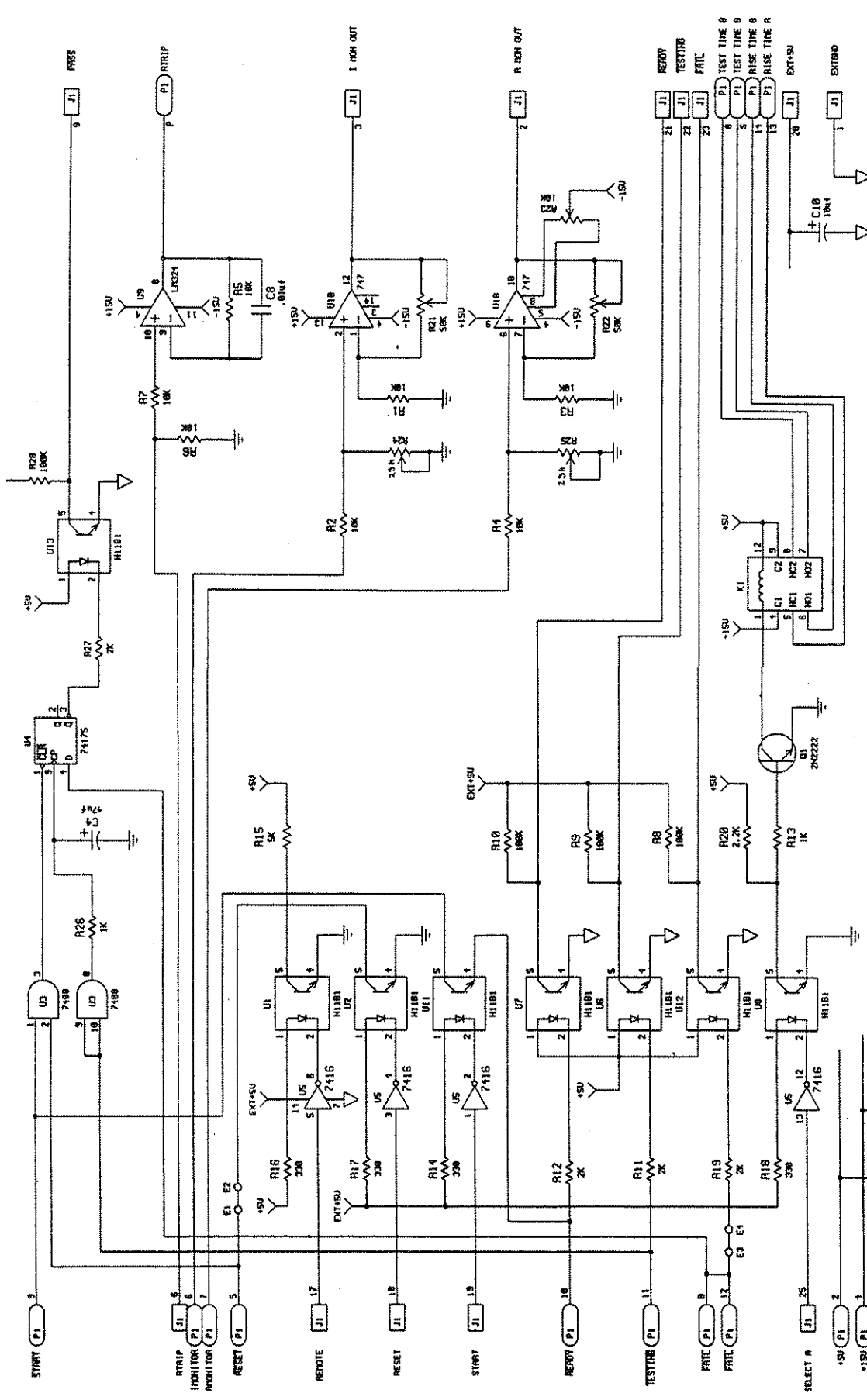

ROD-L ELECTRONICS, INC.
 222 HAMILTON MANOR
 BELLEVILLE, CALIFORNIA 94705
 (415) 322-8711

SCHEMATIC DIAGRAM
 AB REMOTE CONTROL
 OPTION 01, OPTION 19

DATE: 11-15-81
 DRAWN BY: [blank]
 CHECKED BY: [blank]
 TITLE: [blank]

PART NO. 01210-04
 REV. D

SHEET 1 OF 1

EXT+5V

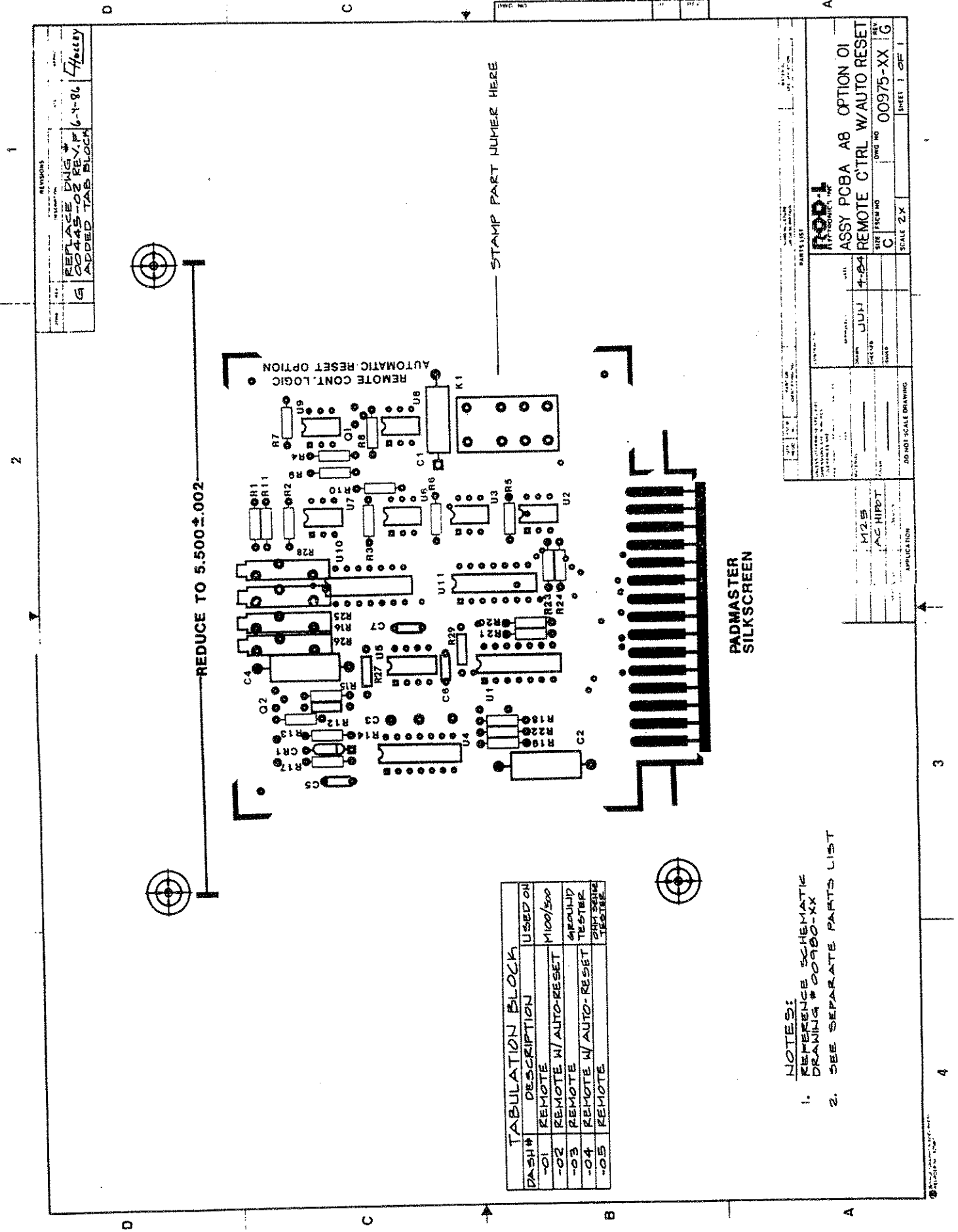

REVISIONS

REV	DESCRIPTION	DATE
1	REPLACE DING	6-1-86
2	COAS-02 REV. F	
3	ADDED TAB BLOCK	

Holley

TABULATION BLOCK

DASH#	DESCRIPTION	USED ON
-01	REMOTE	M100/500
-02	REMOTE W/AUTO-RESET	460411D
-03	REMOTE	TESTER
-04	REMOTE W/AUTO-RESET	2100/2000
-05	REMOTE	

- NOTES:
1. REFERENCE SCHEMATIC DRAWING # 00980-XX
 2. SEE SEPARATE PARTS LIST

ROD-1

ASSY PCB A8 OPTION 01
REMOTE C'TRL W/AUTO RESET

DATE: JUN 4-84

SCALE: 2X

SHEET 1 OF 1

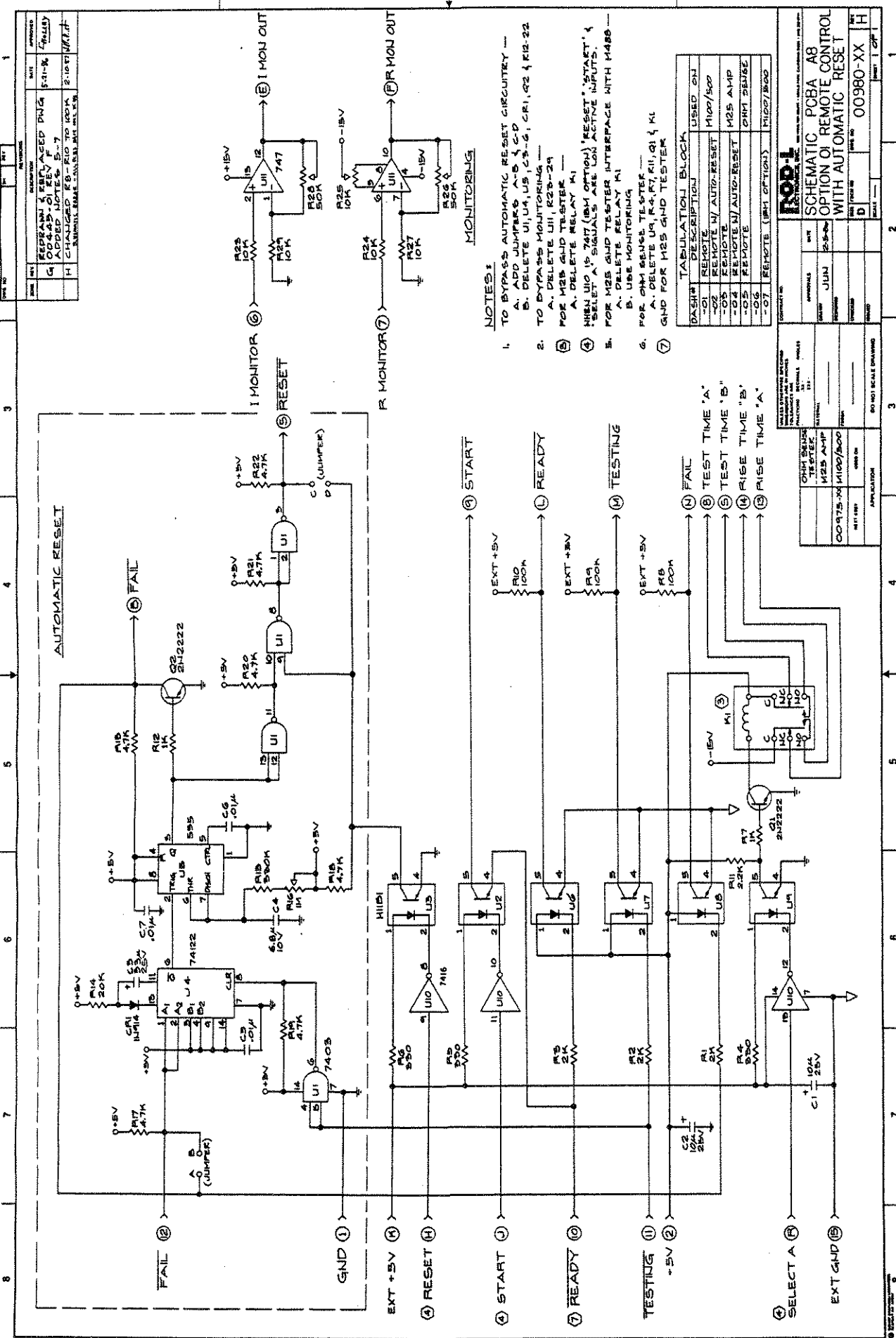

DWG. NO. _____ SH _____ REV _____

REVISIONS		
REV	DESCRIPTION	DATE
A	Initial release	29 AG 86
B	Redrawn, Corrected use	July 94
C	Added Ground	6 Fe 95
D	Added note 3 & moved #5	11 My 95

SYSTEM OBJECTIVE
To perform a Ground Continuity, then an AC Hipot test automatically through one high voltage receptacle and with one press of the start switch.

SYSTEM SELF CHECK
Use the interface cable (P/N 00333-04) to connect the "interface connectors at the rear of each unit to each other.

① Connect "Chassis Ground Sense" (BP2, the black banana jack) at rear of the Ground Continuity Tester to "Chassis Ground Sense" (BP2) at the front the Hipot Tester.

② Connect "Ground" (the metal banana jack) at rear of the Ground Continuity Tester to "Ground" (the metal banana jack) at rear of the Hipot Tester.

③ Connect the High Current Ground Cable (P/N 00436-04; giant banana plug at one end, battery clip at the other) to the "Chassis Ground Sense" at the front of the Ground Continuity Tester and to it's metal chassis frame.

④ The function select switch of the Ground Continuity Tester should be in the "GND/HIPOT" position.

⑤ Plug both units into a common-ground AC outlet. Turn power of the Ground Continuity Tester on first, then power on the Hipot Tester. Both ready lights should then come on.

⑥ Press the Ground Continuity Tester's start button. The test begins, and after the ground continuity test is completed, the Hipot Tester will start automatically.

Now the system is ready for use.

SYSTEM USE
Assuming units are calibrated to the desired trip points, remove ground cable connection to the Ground Continuity Tester and connect it to the metal chassis frame of the Device Under Test (DUT).
Plug the DUT into the high voltage receptacle of the Ground Continuity Tester.
Press the Ground Continuity Tester's start button to begin the test.
For individual machine difficulties, see the appropriate manual.

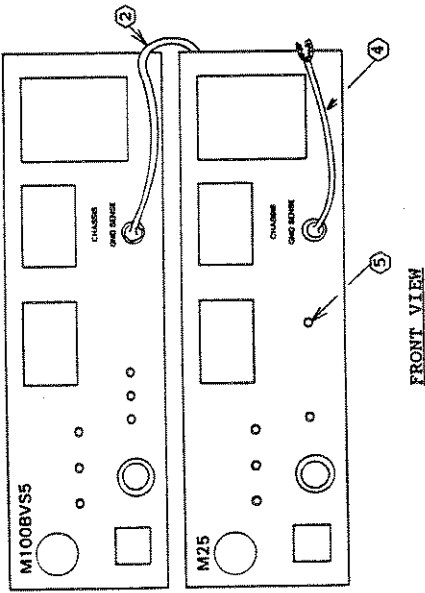

FRONT VIEW

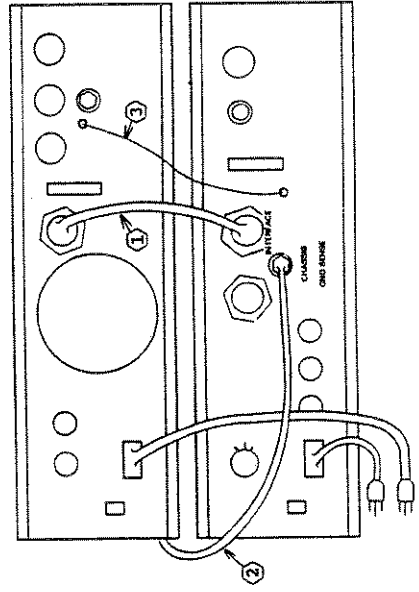

REAR VIEW

UNLESS OTHERWISE SPECIFIED DIMENSIONS ARE IN INCHES FRACTIONS DECIMALS ANGLES 1/8 1/16 1/32 1/64 ±		CONTRACT NO.	
MATERIAL	DATE	APPROVALS	DATE
FRESH	JY 94	EDS	JY 94
DO NOT SCALE DRAWING	DRAWN	CHECKED	REVISED
NEXT ASBY	USED ON	SIZE	FSCM NO.
APPLICATION		B	
		DWG. NO.	01075-01
		SCALE	SHEET
			D



DIAGRAM -- SYSTEM HOOKUP
GT -- AV/BV INTERFACE

REVISIONS

REV.	DESCRIPTION	DATE	APPROVED
A	Initial release	29 AG 86	C Holley
B	Redrawn, Corrected use	July 94	EDS
C	Added ground & moved #s	6 Fe 95	EDS
D		11 My 95	EDS

SYSTEM OBJECTIVE
To perform a Ground Continuity, then a DC Hipot test automatically through one high voltage receptacle and with one press of the start switch.

SYSTEM SELF CHECK
Use the 4-pin-HV-connector interface cable (P/N 00333-04) to connect the "interface" connector at the rear of the Ground Continuity Tester to the "Gnd Tester" connector at the rear of the M100DC.

Connect together the "Chassis Ground Sense" (black banana jack) at rear of each unit using a jumper cable with a standard banana plug at each end.

Connect "Ground" (the metal banana jack) at rear of the Ground Continuity Tester to "Ground" (the metal banana jack) at rear of the Hipot Tester.

Connect the High Current Ground Cable (P/N 00436-04; giant banana plug at one end, battery clip at the other) to the "Chassis Ground Sense" at the front of the Ground Continuity Tester and to it's metal chassis frame.

The function select switch of the Ground Continuity Tester should be in the "GND/HIPOT" position.

Plug both units into a common-ground AC outlet. Turn power of the Ground Continuity Tester on first, then power on the Hipot Tester. Both ready lights should then come on. If the M100DC ready light is not on, press the reset button.

Press the Ground Continuity Tester's start button. The test begins, and after the ground continuity test is completed, the Hipot Tester will start automatically.

Now the system is ready for use.

SYSTEM USE

1 Assuming units are calibrated to the desired trip points, remove ground cable connection to the Ground Continuity Tester and connect it to the metal chassis frame of the Device Under Test (DUT).

2 Plug the DUT into the high voltage receptacle of the Ground Continuity Tester.

3 Press the Ground Continuity Tester's start button to begin the test.

4 For individual machine difficulties, see the appropriate manual.

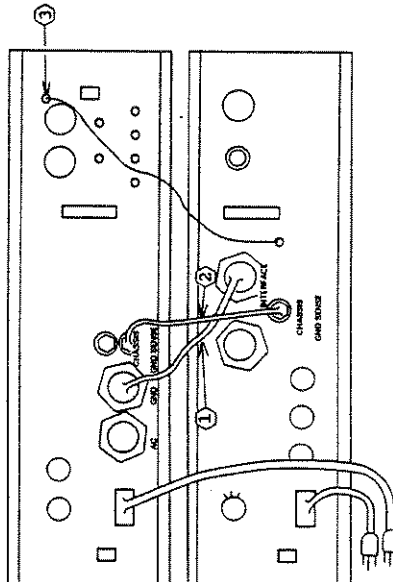
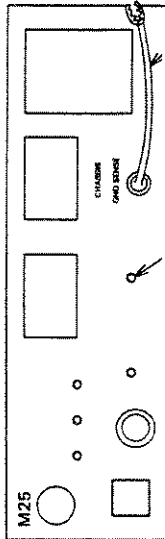
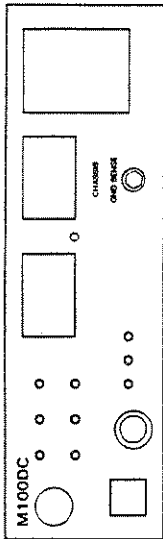

ROD-I ELECTRONICS, INC.
670 HUNTON AVENUE • MEMO PARK, CALIFORNIA 90205 • (415) 362-2711

DIAGRAM - SYSTEM HOOKUP
GT - DC INTERFACE

CONTRACT NO. _____ DATE **JY 94**

APPROVALS: **EDS**

DRAWN: _____ CHECKED: _____

SIZE: **B** DWG. NO. **01076-01**

REVISIONS: **D**

SCALE: _____ SHEET: _____

UNLESS OTHERWISE SPECIFIED	CONTRACT NO.
TOLERANCES ARE:	
FRACTIONS DECIMALS ANGLES	
1/16 0.0625 30	
1/32 0.03125 15	
1/64 0.015625 7.5	
MATERIAL:	
FINISH:	
DO NOT SCALE DRAWING	

APPLICATION
NEXT ASBY
USED ON

DWG. NO.		SH	REV.	REVISIONS	
			A	Initial release	29 AG 86
			B	Redrawn, Corrected use	11 MY 95
					C Holley EDS

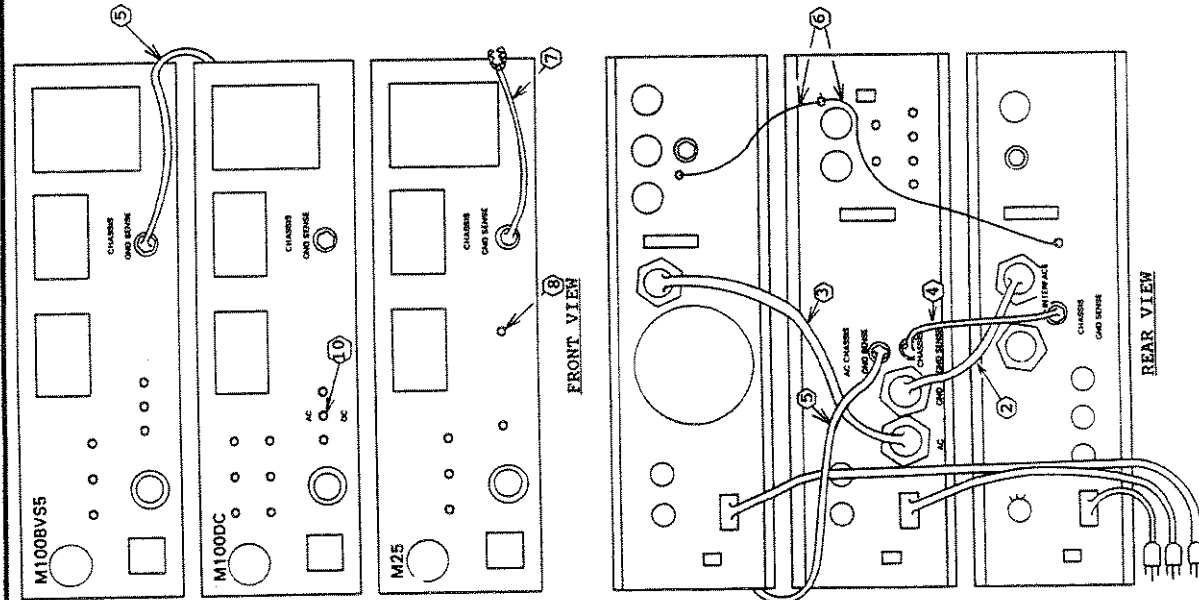

SYSTEM OBJECTIVE
To perform Ground Continuity and AC or DC Hipot tests automatically through one high voltage receptacle.

SYSTEM SELF CHECK

- 1 Stack three units as shown.
- 2 Use a 4-pin-HV-conductor interface cable (P/N 00333-04) to connect the "interface" connector at the rear of the Ground Continuity Tester to the "Grid Tester" connector at the rear of the M100DC.
- 3 Use a 4-pin-HV-conductor interface cable (P/N 00333-04) to connect the "interface" connector at the rear of the AV or BV Hipot Tester to the "AC Hipot" connector at the rear of the M100DC.
- 4 Connect together the "Chassis Ground Sense" (black banana jack) at rear of the Ground Continuity Tester and rear of the M100DC using a jumper cable with a standard banana plug at each end.
- 5 Connect "Chassis Ground Sense" (the black banana jack) at front of the AV or BV Hipot Tester to "AC Chassis Gnd Sense" at the rear of the M100DC Hipot Tester by jumper cable with a standard banana plug at each end.
- 6 Connect all the "Ground"s (the metal banana jack) together at the rear of the Testers.
- 7 Connect the "High Current Ground Cable (P/N 00436-04; giant banana plug at one end, battery clip at the other) to the "Chassis Ground Sense" at the front of the Ground Continuity Tester and to it's metal chassis frame.
- 8 The function select switch of the Ground Continuity Tester should be in the "GND/HIPOT" position.
- 9 Plug the three units into an AC outlet. Turn power of the Ground Continuity Tester on first, then power on the Hipot Testers. The ready lights should then come on. Ready lights for the AV or BV and the M100DC correspond to the position of the "AC/DC" switch on the M100DC. Always press the "reset" button after switching from "AC" to "DC" to ensure the Ready light on the M100DC comes on.
- 10 To perform a DC test, put the "AC/DC" switch on the front of the M100DC in the "DC" position and press the START button of the Ground Continuity Tester. The ground continuity test begins, and when completed, the M100DC Hipot Tester will start automatically.

To perform an AC test, put the "AC/DC" switch on the front of the M100DC in the "AC" position and press the START button of the Ground Continuity Tester. The ground continuity test begins, and when completed, the AC Hipot Tester will start automatically.

Now the system is ready for use.

SYSTEM USE WITH THE DEVICE UNDER TEST

- 1 Assuming units are calibrated to the desired trip points, remove ground cable connection from the frame of the Ground Continuity Tester and connect it to the metal chassis frame of the Device Under Test (DUT).
- 2 Plug the DUT into the high voltage receptacle of the Ground Continuity Tester and follow procedures 10 above.
- 3 For individual machine difficulties, see the appropriate manual. **WARNING!!!** High Voltage is present on both receptacles during the test at "AC" position.

UNLESS OTHERWISE SPECIFIED DIMENSIONS ARE IN INCHES		FRACTIONS: 1/16" 1/8" 1/4" 3/8" 1/2" 5/8" 3/4" 1" 1 1/2" 2" 3" 4" 6" 8" 12"		TOLERANCES ARE:		MATERIAL:		FINISH:	
CONTRACT NO.		APPROVALS		DATE		DRAWN		CHECKED	
		EDS		MY 95					
DRAWN		DATE		APPROVED		DATE		APPROVED	
EDS		MY 95							
CHECKED									
TESTED									
DO NOT SCALE DRAWING		SCALE		SHEET		REV.		REV.	
						B		01078-01	
						SIZE		FSCM NO.	
						DWG. NO.		01078-01	



2021 HAMILTON AVENUE - HENKLO PARK, CALIFORNIA 94532-0111
DIAGRAM - SYSTEM HOOKUP
GT - DC - AV/BV INTERFACE

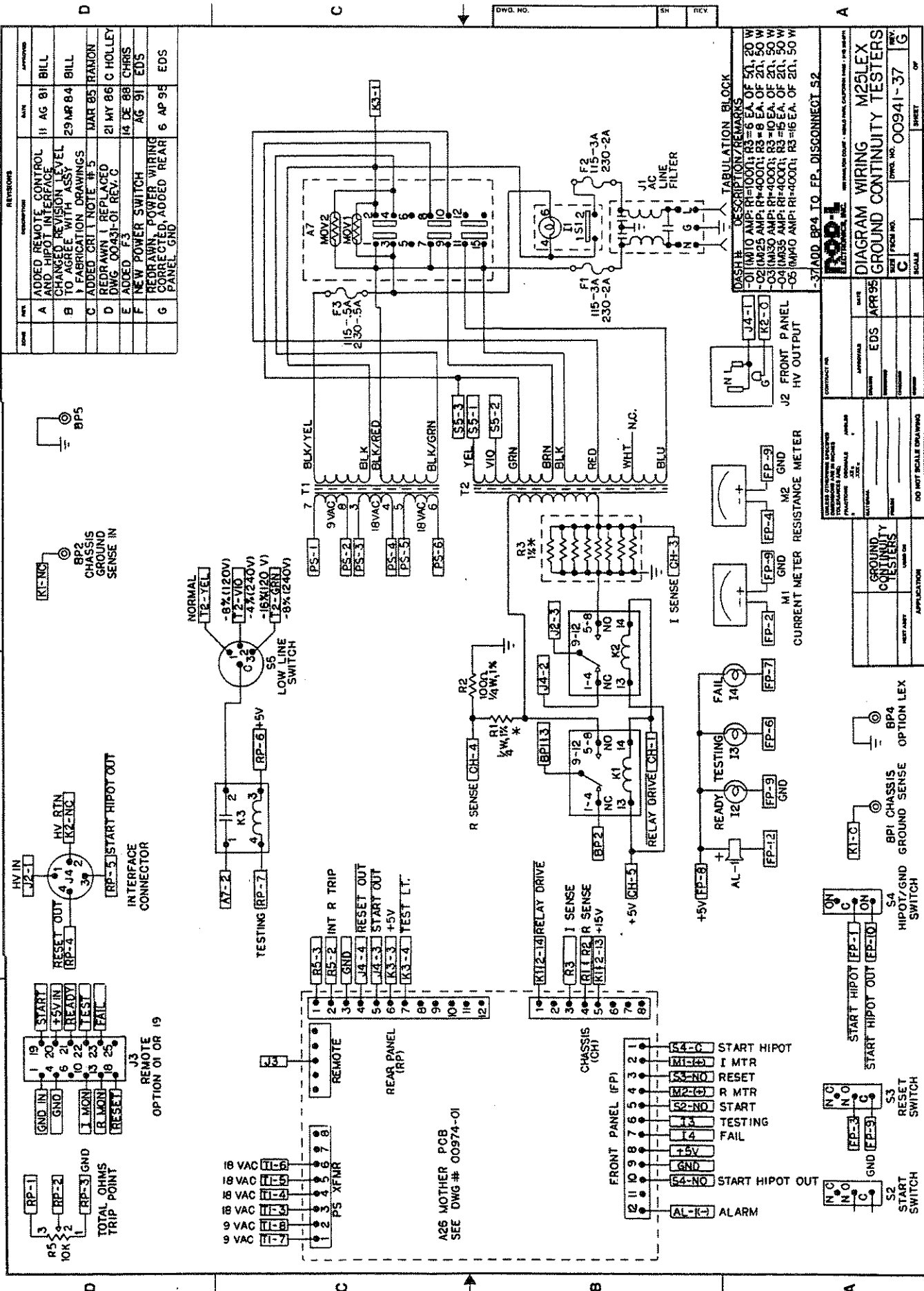

REV	DESCRIPTION	DATE	APPROVED
A	ADDED REMOTE CONTROL AND HIPOUT INTERFACE	11 AG 81	BILL
B	CHANGED REVISION LEVEL TO AGREE WITH ASSY FABRICATION DRAWINGS	29 MAR 84	BILL
C	ADDED CRI NOTE #5	12 MAR 85	RANON
D	REDRAWN I REPLACED DWG 00431-01 REV C	21 MAY 86	C HOLLEY
E	ADDED F3	14 DE 88	CHRIS
F	NEW POWER SWITCH	AG 91	EDS
G	REDRAWN POWER WIRING CORRECTED, ADDED REAR PANEL_GND	6 AP 95	EDS

DASH #	DESCRIPTION/REMARKS
01	100 TO AMP; R1=1000; R3=6 EA. OF 50, 50 W
02	1M25 AMP; R1=400; R3=8 EA. OF 20, 50 W
03	1M50 AMP; R1=400; R3=10 EA. OF 20, 50 W
04	1M55 AMP; R1=400; R3=10 EA. OF 20, 50 W
05	1M60 AMP; R1=400; R3=10 EA. OF 20, 50 W

POE	
DIAGRAM WIRING M25LEX	
GROUND CONTINUITY TESTERS	
DATE	APR 95
DESIGNED BY	EDS
CHECKED BY	EDS
SCALE	C
FIG. NO.	00941-37
REV.	G

1

2

3

4

DO NOT SCALE DRAWING

GROUND CONTINUITY TESTERS

OPTION LEX

BP4

BP1 CHASSIS GROUND SENSE

BP5

BP2 CHASSIS GROUND SENSE IN

BP3

BP4

BP5

BP6

BP7

BP8

BP9

BP10

BP11

BP12

BP13

BP14

BP15

BP16

BP17

BP18

BP19

BP20

BP21

BP22

BP23

BP24

BP25

BP26

BP27

BP28

BP29

BP30

BP31

BP32

BP33

BP34

BP35

BP36

BP37

BP38

BP39

BP40

BP41

BP42

BP43

BP44

BP45

BP46

BP47

BP48

BP49

BP50

BP51

BP52

BP53

BP54

BP55

BP56

BP57

BP58

BP59

BP60

BP61

BP62

BP63

BP64

BP65

BP66

BP67

BP68

BP69

BP70

BP71

BP72

BP73

BP74

BP75

BP76

BP77

BP78

BP79

BP80

BP81

BP82

BP83

BP84

BP85

BP86

BP87

BP88

BP89

BP90

BP91

BP92

BP93

BP94

BP95

BP96

BP97

BP98

BP99

BP100

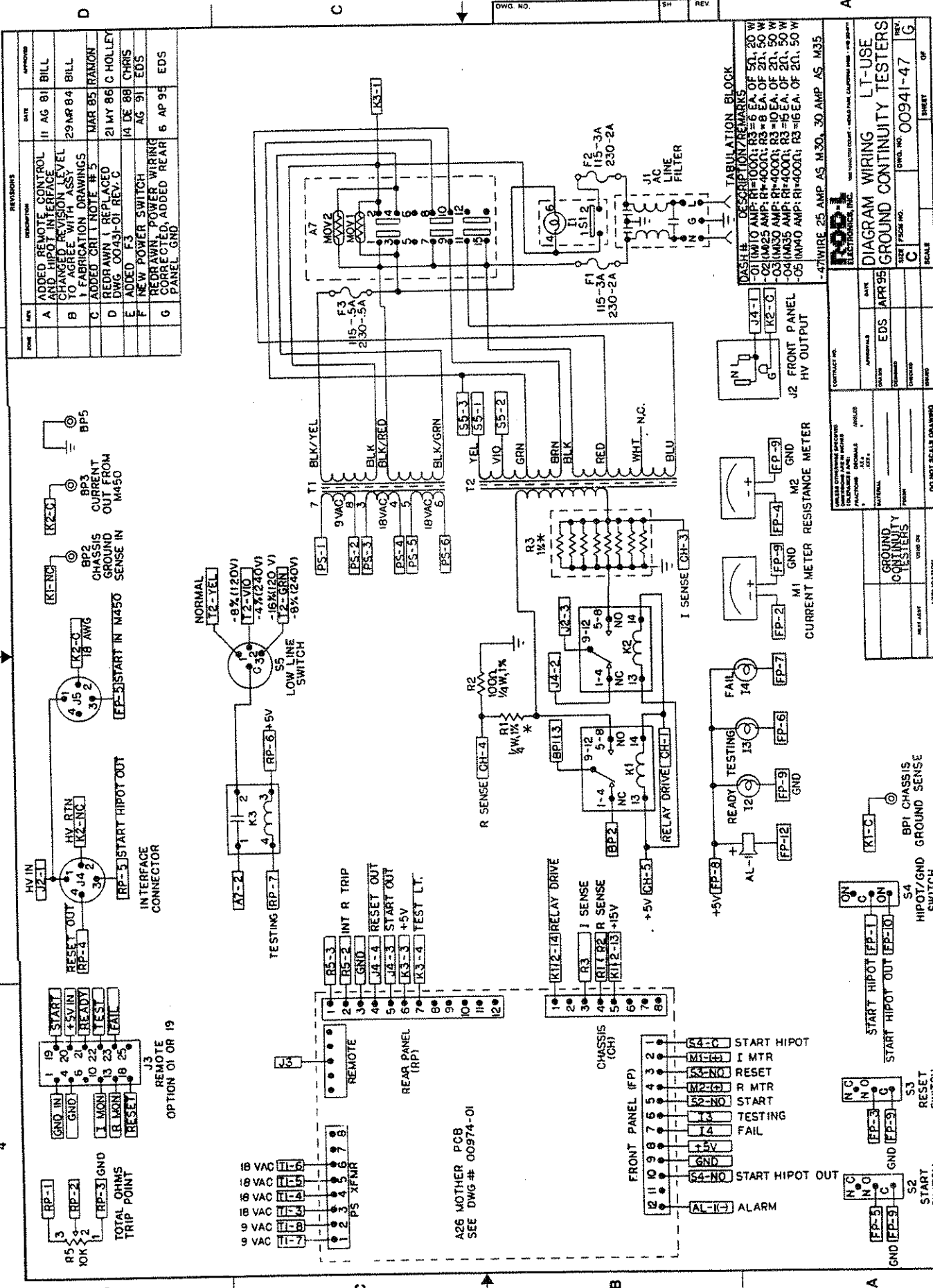

REV	DATE	DESCRIPTION	APPROVED
A	II AG 81	ADDED REMOTE CONTROL AND HIPOUT SECTION	BILL
B	29 MAR 84	CHANGED WIRING ASSY LEVEL 1 FABRICATION DRAWINGS	BILL
C	MAR 85	ADDED CRT NOTE #5	RAMON
D	21 MY 86	REWORKED AND REPLACED DWG COPY OF REV. C	C HOLLEY
E	14 DE 88	ADDED F3	CHRIS
F	AG 91	NEW POWER SWITCH	EDS
G	6 AP 95	REDRAWN, POWER WIRING CORRECTED, ADDED REAR PANEL GND	EDS

DASH #	DESCRIPTION/REMARKS
01	1M10 AMP; R1=100Ω; R3=6 EA. OF 5A, 20 W
02	1M25 AMP; R1=400Ω; R3=8 EA. OF 21, 50 W
03	1M30 AMP; R1=400Ω; R3=10 EA. OF 21, 50 W
04	1M35 AMP; R1=400Ω; R3=15 EA. OF 21, 50 W
05	1M40 AMP; R1=400Ω; R3=16 EA. OF 21, 50 W

CONTRACT NO.	DATE	APPROVED	EDS APR 95
DESIGNED	EDS	EDS	EDS
CHECKED	EDS	EDS	EDS
SCALE	C	SIZE	FRONT PANEL
SHEET	1	OF	1
GROUND CONTINUITY TESTERS		DWG. NO.	00941-47

CONTRACT NO.	DATE	APPROVED	EDS APR 95
DESIGNED	EDS	EDS	EDS
CHECKED	EDS	EDS	EDS
SCALE	C	SIZE	FRONT PANEL
SHEET	1	OF	1
GROUND CONTINUITY TESTERS		DWG. NO.	00941-47

CONTRACT NO.	DATE	APPROVED	EDS APR 95
DESIGNED	EDS	EDS	EDS
CHECKED	EDS	EDS	EDS
SCALE	C	SIZE	FRONT PANEL
SHEET	1	OF	1
GROUND CONTINUITY TESTERS		DWG. NO.	00941-47

CONTRACT NO.	DATE	APPROVED	EDS APR 95
DESIGNED	EDS	EDS	EDS
CHECKED	EDS	EDS	EDS
SCALE	C	SIZE	FRONT PANEL
SHEET	1	OF	1
GROUND CONTINUITY TESTERS		DWG. NO.	00941-47

CONTRACT NO.	DATE	APPROVED	EDS APR 95
DESIGNED	EDS	EDS	EDS
CHECKED	EDS	EDS	EDS
SCALE	C	SIZE	FRONT PANEL
SHEET	1	OF	1
GROUND CONTINUITY TESTERS		DWG. NO.	00941-47

A26 MOTHER PCB
SEE DWG # 00974-01

1

2

3

4

5

6

7

8

9

10

11

12

13

14

15

16

17

18

19

20

21

22

23

24

25

26

27

28

29

30

31

32

33

34

35

36

37

38

39

40

41

42

43

44

45

46

47

48

49

50

51

52

53

54

55

56

57

58

59

60

61

62

63

64

65

66

67

68

69

70

71

72

73

74

75

76

77

78

79

80

81

82

83

84

85

86

87

88

89

90

91

92

93

94

95

96

97

98

99

100

