

# Sentry 50 Ground Bond Tester Instruction Manual

Form 150285/A8

©QuadTech, Inc., 1997

Domestic Sales 800-253-1230

For additional contact information please visit our website  
[www.quadtech.com](http://www.quadtech.com)

The material in this manual is for informational purposes only and is subject to change, without notice. QuadTech assumes no responsibility for any error or for consequential damages that may result from the misinterpretation of any procedures in this publication.

## WARNING

Potentially dangerous energy levels may be present on the front and rear panel terminals. Follow all warnings in this manual when operating or servicing this instrument. Dangerous levels of energy may be stored in capacitive devices tested by this unit. Always make sure the DANGER indicator of high current is **not** on when connecting or disconnecting the device under test.



Product will be marked with this symbol (ISO#3864) when it is necessary for the user to refer to the instruction manual in order to prevent injury or equipment damage.



Product marked with this symbol (IEC417) indicates presence of direct current.



Product will be marked with this symbol (ISO#3864) when voltages in excess of 1000V are present.



---

# Contents

---

<b>Warranty</b>	<b>5</b>
<b>Specifications</b>	<b>7</b>
<b>Accessories</b>	<b>9</b>
<b>Safety Precautions</b>	<b>11</b>
<b>Condensed Operating Instructions</b>	<b>13</b>

## **Introduction - Section 1**

1.1	Unpacking and Inspection	15
1.2	Product Overview	15
1.3	Controls and Indicators	16
1.3.1	Front Panel Controls and Indicators	16
1.3.2	Rear Panel Controls and Connectors	18
1.4	Installation	19
1.4.1	Dimensions	19
1.4.2	Instrument Positioning	19
1.4.3	Power Requirements	19
1.4.4	Safety Inspection	21

## **Operation - Section 2**

2.1	Startup	23
2.2	Instrument Zeroing/Offset	24
2.3	Connection to Device Under Test	25
2.4	Measurement Procedure	26
2.5	Programming Sequential Tests	27
2.6	Programming Test Parameters	28
2.7	Special Function Key Lock	29
2.8	Software Version Display	30
2.9	Clear Setup Memory	30
2.10	Fail Continuous Mode	30
2.11	Beeper Setup Mode	31
2.12	Voltage Limit	32
2.13	Remote Control	32
2.14	Use With Sentry 10/20/30 or 15/25/35	34
2.15	G16 International Power Strip	36

## **Service & Maintenance - Section 3**

3.1	General	37
3.2	Instrument Return	37
3.3	Calibration	37
3.3.1	Calibration Equipment	37
3.3.2	Calibration Procedure	38



---

## Warranty

---



QuadTech warrants that Products are free from defects in material and workmanship and, when properly used, will perform in accordance with QuadTech's applicable published specifications. If within one (1) year after original shipment it is found not to meet this standard, it will be repaired, or at the option of QuadTech, replaced at no charge when returned to a QuadTech service facility.

**Changes in the Product not approved by QuadTech shall void this warranty.**

**QuadTech shall not be liable for any indirect, special or consequential damages, even if notice has been given of the possibility of such damages.**

**This warranty is in lieu of all other warranties, expressed or implied, including, but not limited to any implied warranty or merchantability or fitness for a particular purpose.**

### SERVICE POLICY

QuadTech's service policy is to maintain product repair capability for a period of at least five (5) years after original shipment and to make this capability available at the then prevailing schedule of charges.



---

## Specifications

---

**Output Current:** Range: 3.00 to 30.00A AC, setting 0.01A/step  
Useable down to 1.00A  
Accuracy:  $\pm$  (1% of setting + 0.3A)  
 $\pm$  (2% of reading + 5 counts)  
Frequency: 50 or 60Hz

**Voltage Limit:** Range: 6.0 to 15VAC, setting 0.1V/step

**Resistance:** Range: 0.1m $\Omega$  - 510.0m $\Omega$ , 4 digits, Hi Limit  
Accuracy:  $\pm$  (1% of reading + 5 counts)

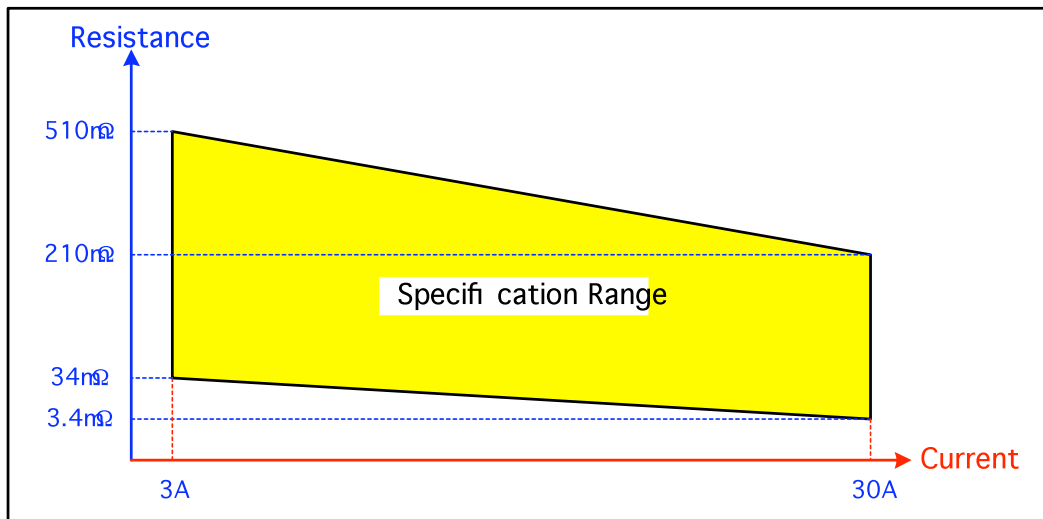

**Sentry 50 Resistance Specification Range**

**Offset Function:** 0 to 100mohm offset, user selectable

**Test Time:** 0.1 - 999sec ( $\pm$ 20ms) for  $I < 25A$  AC  
0.1 - 60sec ( $\pm$ 20ms) for  $I \geq 25 A$  AC  
Resolution: 0.1sec for test times  $< 100$ sec  
Resolution: 1sec for test times  $\geq 100$ sec.  
Continuous operation mode

**Remote Control:** Remote Start, Stop, Interlock, Pass/Fail Output  
via 9-Pin D Series Connector and Terminal Strip  
INPUTS: Start/Stop/Interlock: active low  
OUTPUTS: Pass/Fail: via relays 115V AC 300mA

---

## Specifications (Continued)

---

**Mechanical:** Bench Mount  
Carry Handle  
Dimensions: (w x h x d): 11x4x15in (270x100x370mm)  
Weight: 25 lbs (12kg) net, 28 lbs (13kg) shipping

**Environmental:** Meets MIL-T-28800E, Type 3, Class 5  
Operating: 0°C to + 40°C  
Humidity: <80%  
Storage: - 10°C to + 60°C

**Power:**

- 90 - 130V AC
- 50 or 60Hz
- 200 - 250V AC
- 500W max

**Supplied:**

- Instruction Manual
- Calibration Certificate
- AC Power Cable
- Test Leads (G15)

**Optional:**

- S15 Interconnection Cable to Sentry 10-35 Hipot Testers
- S16 Rack Mount Kit
- S05 Foot Switch
- G13 Corded Product Adapter (115V)
- G14 Power Entry Adapter
- G15 Ground Continuity Lead Set
- G16 International Power Strip
- G25 Corded Product Adapter (240V)

**Ordering Information:**

<u>Description</u>	<u>Catalog Number</u>
Sentry 50 Ground Bond Tester	Sentry 50



# Accessories

## Accessories Included

Item	Quantity	QuadTech P/N
U.S. AC Power Cable (3-prong)	1	4200-0300
Ground Continuity Lead Set	1	G15
5A 250V Line Fuse	2	
Instruction Manual	1	150285
Calibration Certificate	1	N/A

## Accessories/Options Available

Item	Quantity	QuadTech P/N
Foot Switch	1	S05
Interconnect Cable (To Sentry 10/20/30 & 15/25/35)	1	S15
Rack Mount Assembly	1	S16
Corded Product Adaptor, 115V, use for GB test	1	G13
Corded Product Adaptor, 240V, use for GB test	1	G25
Power Entry Adaptor Cable	1	G14
International Power Strip	1	G16



**Figure A-1: G15 Ground Continuity Lead Set**



**Figure A-2: G13 Corded Product Adaptor**



---

## Safety Precautions

---

### WARNING

The Sentry Ground Bond Tester can provide an output current as high as 30A AC to the external device under test (DUT).

Although the Sentry unit is designed with full attention to operator safety, serious hazards could occur if the instrument is used improperly and these safety instructions are not followed.

1. The Sentry unit is designed to be operated with its chassis connected to earth ground. The Sentry instrument is shipped with a three-prong power cord to provide this connection to ground. The power cord should only be plugged in to a receptacle that provides earth ground. Serious injury can result if the Sentry unit is not connected to earth ground.
2. Tightly connect cable(s) to the (black) **GND** terminal. If this is not done, the DUT's casing can be charged to the high current test level and serious injury or electrical shock hazards could result if the DUT is touched.
3. Never touch the metal of the test probes directly. Touch only the insulated parts of the lead(s).
4. Never touch the test leads, test fixture or DUT in any manner (this includes insulation on all wires and clips) when the high current is applied and the red **DANGER** LED is lit.
5. Before turning on the Sentry unit, make sure the AC power cord is plugged into the proper voltage source and that there is no device (DUT) or fixture connected to the test leads.
6. After each test, press the **[STOP]** (red) button for safety. This terminates the high current being applied to the output terminals.
7. When the **DANGER LED** is lit NEVER touch the device under test, the lead wires or the output terminals.
8. Before touching the test lead wires or output terminals make sure:
  - a) The red **[STOP]** button has been pressed.
  - b) The **DANGER LED** is OFF.
  - c) The output current display is 0 (zero).
9. **In the case of an emergency**, turn OFF the [POWER] switch using a "hot stick" and disconnect the AC power cord from the wall. **DO NOT TOUCH THE Sentry INSTRUMENT.**
10. If the **DANGER LED** does not go off when the **[STOP]** button is pressed, immediately stop using the tester. It is possible that the output voltage is still being delivered regardless of the TEST ON/OFF control signal.
11. When the Sentry instrument is used in remote control mode, be extremely careful. The high current output is being turned on and off with an external signal.



---

## Condensed Operating Instructions

---

### WARNING

High Current is applied to the output terminals anytime the red **DANGER** LED is on or flashing. Always make sure the **DANGER** LED is OFF when connecting or disconnecting the device under test (DUT).

### General Information

The Sentry 50 Ground Bond tester is a measuring instrument for direct readout of high current ground continuity (ground bond) between chassis and power cord ground. An excellent choice for electrical safety testing on a wide variety of electrical products and appliances. The current applied to the device under test is adjustable from 1A to 30A AC in 0.01A steps. The voltage range is 6.0V to 15VAC with a 0.01V/step setting. The resistance range is from 0.1m $\Omega$  to 510m $\Omega$  with adjustable high and low limits. PASS and FAIL LEDs provide a visual display of test results based on preset limits. In FAIL mode, a buzzer gives an audible indication of test result based on preset limit.

### Start-Up

The Sentry unit can be operated from a power source between 90 and 250VAC at a power line frequency of 50 or 60Hz. The Sentry 50 unit is shipped from QuadTech with a 5A fuse in place for AC 100-240V operation. The Sentry 50 unit is shipped with the line voltage selector set for 120V. Refer to paragraph 1.4.3 to change a fuse and to change the line voltage selector.

Connect the Sentry instrument AC power cord to the source of proper voltage.

Press the [POWER] button on the front panel to apply power. To switch the power off press the [POWER] button again or if measurements are to be made proceed with Test Parameter Set-Up below. Note: the Sentry instrument should warm-up for 15 minutes prior to use.

### Test Parameter Set-Up

Press [PROG] and enter the Test Parameters according to your test specification. The Sentry 50 instrument will prompt the operator to set:

Test Current  
Test Frequency  
High Resistance Limit  
Low Resistance Limit  
Test Time

Press [ENTER] to accept each parameter after entering that parameter. Press [ENTER] at completion of entering all parameters to accept the set of test conditions.

Press [PROG] to exit programming mode.

Refer to paragraph 2.6 for full description of programming test parameters and instruction on how to store the test setup. Note: Test parameters must be set before the Sentry unit can be zeroed.

---

# Condensed Operating Instructions

---

## Zeroing/Offset

After setting the test parameters, zero the Sentry unit by using the automatic offset. Make sure the black cables are connected to the Sentry LOW (Drive-, Sense-) terminals and the red test cables are connected to the Sentry HIGH (Sense+, Drive+) terminals and the clips shorted. Press [ENTER] key twice. Display reads “OFSt oFF”. Press [UP] key once. Display reads “OFSt GET”. Press [START] key once. Display shows the offset. Offset has to be recalculated each time the test parameters, test cables or test fixture are changed.

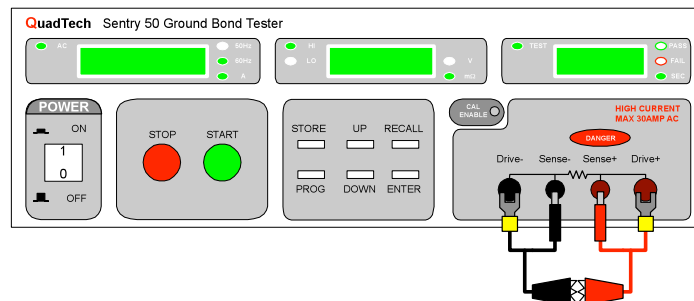

**Figure COI-1: Cable Connection for Offset Function**

## Measurement Mode

- 1 Turn [POWER] ON. Let Sentry unit warm-up 15 minutes.
- 2 Connect Black cables to Sentry Drive- & Sense- terminals.
- 3 Connect Red cables to Sentry Sense+ & Drive+ terminals.
- 4 Press [PROG] and enter your Test Parameters Press [PROG] again to accept it.
- 5 [STORE] Test set-up (If desired).
- 6 Zero the Sentry unit (OFFSET).
- 7 Connect Device Under Test (DUT).
- 8 Press [START].
- 9 Record Readings.
- 10 Press [STOP] .

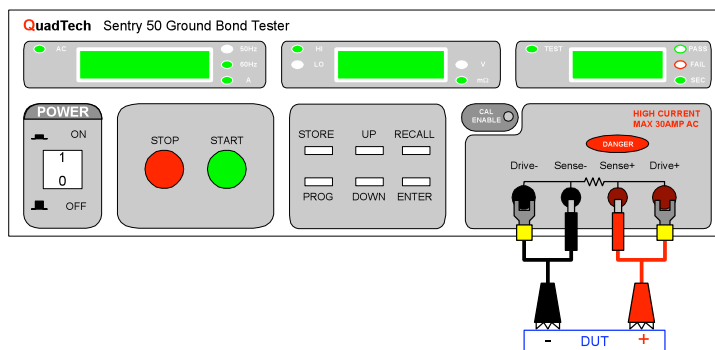

**Figure COI-2: Cable Connection To Device Under Test**

---

## Section 1: Introduction

---

### 1.1 Unpacking and Inspection

Inspect the shipping carton before opening. If the carton is damaged, contact the carrier agent immediately. Inspect the Sentry 50 instrument for any damage. If the instrument appears damaged or fails to meet specifications notify QuadTech (refer to instruction manual front cover) or its local representative. Retain shipping carton and packing materials for future use such as returning for recalibration or service.

### 1.2 Product Overview

The Sentry 50 instrument provides for verification of ground continuity connection (ground bond testing) between conductive surfaces and power cord ground on the product under test. The Sentry 50 instrument can be programmed for an output current up to 30 amps and for high/low resistance measurement limits between 0.1m $\Omega$  and 510m $\Omega$ . The instrument also provides memory for internal storage of 10 test setups and remote control capability with start/stop inputs and pass/fail outputs. The Sentry 50 instrument can be connected to the Sentry Series Hipot tester for a complete product test (hipot preceded by ground bond) with the push of one button.

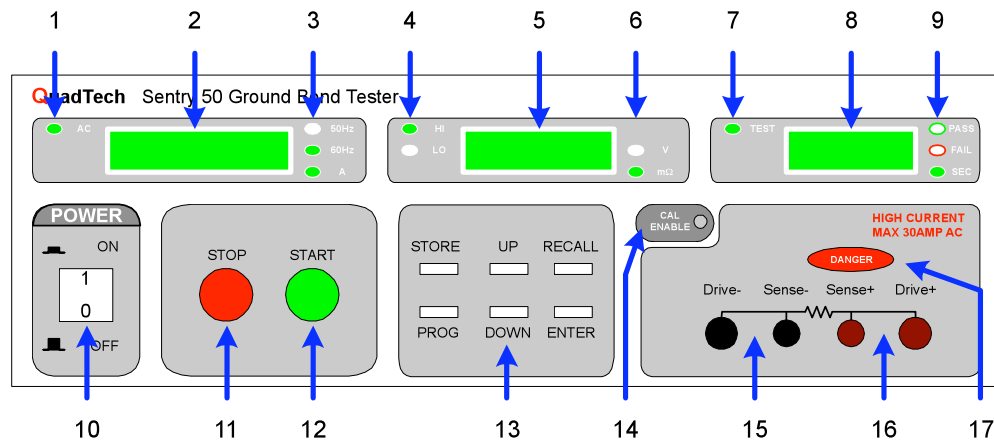

**Figure 1-1: Sentry 50 Ground Bond Tester**

### 1.3 Controls and Indicators

#### 1.3.1 Front Panel Controls and Indicators

Figure 1 illustrates the controls and indicators on the front panel of the Sentry 50 Ground Bond Tester. Table 1-1 identifies them with description and function.



**Figure 1-2: Sentry 50 Front Panel Controls and Indicators**

**Table 1-1: Front Panel Controls and Indicators**

Reference Number Figure 1-2	Name	Type	Function
1	AC	Green LED	When lit, indicates AC output current.
2	Current Display	4 ½ digit	Indicates programmed current when test is not in process. Indicates measured current when test is in process (reading retained at completion of test).
3	50Hz, 60Hz, A	Green LEDs	When lit, indicates output frequency and unit of current measure is Amps.
4	HI, LO	Green LEDs	When lit, indicates the function of the limit (HI or LO) shown on the display.
5	Limit Measure Display	3 ½ Digit	Indicates limit setting when test is not in process. Indicates test value (resistance or voltage) when test is in process (reading is retained at completion of test).
6	V, mΩ	Green LEDs	When lit, indicates the unit of measure: mΩ for resistance and V for voltage
7	TEST	Green LED	When lit, indicates test time is set
8	Timer Display	3 ½ Digit	Indicates the programmed test time or countdown time when the test is in process. Programmable: 0.1-999sec for I < 25A or 0.1-60sec for I ≥ 25A. Continuous Operating Mode: T = 0 (zero)

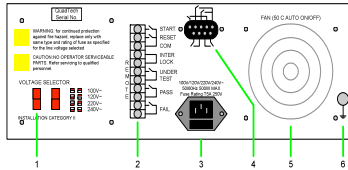

**Table 1-2: Front Panel Controls and Indicators (Continued)**

Reference Number Figure 1-1	Name	Type	Function
9	PASS, FAIL, SEC	Green & Red LEDs	When lit, indicates unit for test time (SEC) and P/F result based on entered limits.
10	POWER	White push-button	Apply AC power: Push IN=ON, OUT=OFF
11	STOP	Red push-button	Pressing [STOP] terminates the test in progress. After a failed test, [STOP] must be pressed as a reset function to initiate new test
12	START	Green push-button	Pressing [START] starts a test and applies current to the output terminals.
13	PROG	White push-button	Press [PROG] to enter programming mode and change test conditions. Press [PROG] to exit programming mode.
	ENTER	White push-button	Press [ENTER] to confirm entered test conditions.
	STORE	White push-button	Press [STORE] to store 1 – 10 test setups.
	RECALL	White push-button	Press [RECALL] to recall 1 – 10 test setups.
	UP	White push-button	In Stand-by mode: selects step 1 or 2. In Programming mode: Increases selected test parameter (Current, limits, time). In Test mode: selects resistance or voltage display.
	DOWN	White push-button	In Stand-by mode: selects step 1 or 2. In Programming mode: Decreases selected test parameter (Current, limits, time). In Test mode: selects resistance or voltage display.
14	CAL ENABLE	Recessed switch	For use by qualified service personnel only during instrument calibration.
15	DRIVE-/SENSE-	Black Banana Plug	LOW connection to device under test (DUT).
16	SENSE+/DRIVE+	Maroon Banana Plug	HIGH connection to device under test (DUT).
17	DANGER	Red LED	When lit or flashing, indicates high current is present at the output terminals.

### 1.3.2 Rear Panel Controls and Connectors

Figure 1-2 illustrates the controls and connectors on the rear panel of the Sentry 50 Ground Bond Tester. Table 1-2 identifies them with description and function.



**Figure 1-3: Rear Panel Controls and Connectors**

**Table 1-2: Rear Panel Connectors and Controls**

Reference Number Figure 1-3	Name	Type	Function
1	VOLTAGE SELECTOR	Red 2-position slide switch	Select Range of AC Power Source: Set to 100V for 90-110V AC operation Set to 120V for 110-130V AC operation Set to 220V for 200-240V AC operation Set to 240V for 220-250V AC operation
2	REMOTE	Black 11-screw terminal strip	Remote Control Connection Inputs: Start, Reset, InterLock Outputs: Under Test, Pass, Fail
3	AC LINE	Black 3-prong receptacle & Fuse Holder	3-wire connection for AC power source. 90-130V AC: 5A 250V 5x20mm Fuse 200-250V AC: 2.5A 250V 5x20mm Fuse
4	REMOTE	Black 9-pin D series connector	Remote Control Connection Inputs: Start, Reset Outputs: Under Test, Pass, Fail
5	FAN	115V, 50-60Hz, 0.1A Fan	Temperature Control Fan: OFF: < 50°C ON: ≥ 50°C
6	Chassis Ground	Silver Banana Plug & screw connector	Instrument Chassis Ground Connection

## 1.4 Installation

### 1.4.1 Dimensions

The Sentry 50 unit is supplied in bench configuration, i.e. in a cabinet with resilient feet for placement on a table. Flip feet are provided under the front feet so that the Sentry 50 instrument can be tilted up for convenient operator viewing.

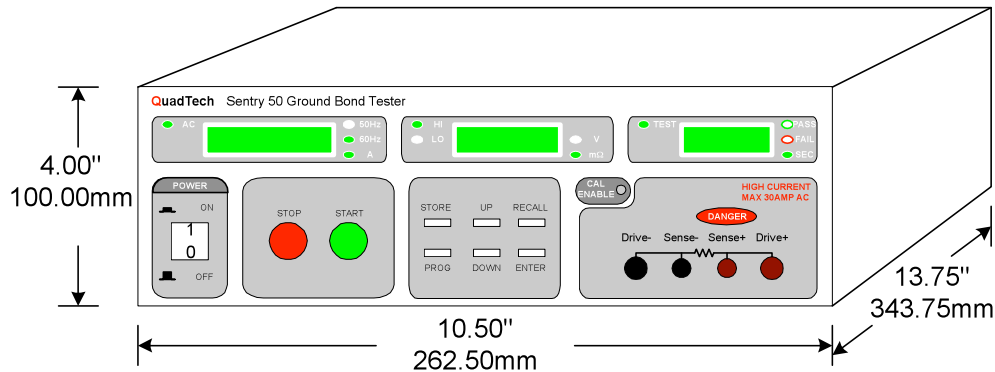

**Figure 1-4: Sentry 50 Instrument Dimensions**

### 1.4.2 Instrument Positioning

The Sentry unit contains three (3) digital meters for direct readout of measured parameters. The optimum angle for viewing is slightly down and about 10 degrees either side of center. For bench operation the front flip feet should always be used to angle the instrument up. In bench or rack mount applications the instrument should be positioned with consideration for ample air flow around the rear panel fan ventilation hole. An open space of at least 3 inches (75mm) is recommended behind the rear panel.

### 1.4.3 Power Requirements

The Sentry 50 instrument can be operated from a power source of 90 to 130 VAC or 200 to 250 VAC. Power connection is via the rear panel through a standard receptacle. Before connecting the 3-wire power cord between the unit and AC power source make sure the voltage selection switches on the rear panel (as indicated) are in accordance with the power source being used, 5A, 250V, 5x20mm, for 90-130V source and 2.5A, 250V, 5x20mm (not supplied) for 200-250V source. Always use an outlet which has a properly connected protection ground.

Figure 1-5 illustrates the voltage selector switches located on the rear panel of the Sentry 50 instrument. Figure 1-6 illustrates the fuse drawer also located on the rear panel of the Sentry 50 instrument.

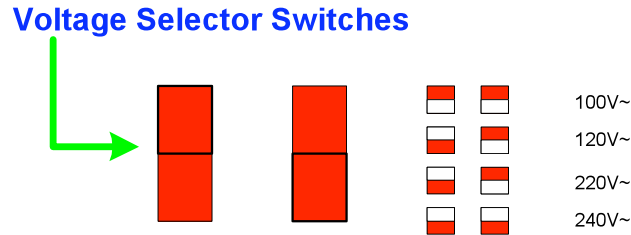

**Figure 1-5: Voltage Selector Switches Rear Panel Sentry 50 Instrument**

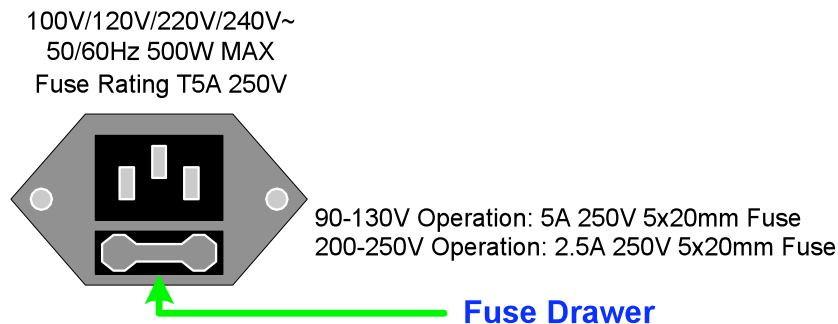

**Figure 1-6: Fuse Drawer Rear Panel Sentry 50 Instrument**

**To change the fuse proceed as follows:**

**WARNING**  
MAKE SURE THE UNIT HAS BEEN DISCONNECTED FROM ITS AC POWER SOURCE FOR AT LEAST FIVE MINUTES BEFORE PROCEEDING.

Remove the fuse drawer, by inserting a flathead screwdriver behind the small tab located just below the 3 prong receptacle as shown in Figure 1-6, and force outward.

Once the fuse drawer has been removed from the instrument snap the fuse from the holder and replace. Make sure the new fuse is of the proper rating. Note that the fuse drawer can also be used to store a spare fuse.

Install the fuse drawer back in the inlet module (fuse down) by pushing in until it locks securely in place.

#### **1.4.4 Safety Inspection**

Before operating the instrument inspect the power inlet module on the rear of the Sentry to ensure that the properly rated fuse is in place, otherwise damage to the unit is possible. Refer to paragraph 1.4.3.

The Sentry instrument is shipped with a standard U.S. power cord, QuadTech P/N 4200-0300 (with Belden SPH-386 socket or equivalent, and a 3-wire plug conforming to IEC 320). CE units are shipped with an approved international cord set. Make sure the instrument is only used with these cables (or other approved international cord set) to ensure that the instrument is provided with connection to protective earth ground.

The surrounding environment should be free from excessive dust to prevent contamination of electronic circuits. The surrounding environment should also be free from excessive vibration. Do not expose the Sentry instrument to direct sunlight, extreme temperature or humidity variations, or corrosive chemicals.



---

## Section 2 : Operation

---

### 2.1 Startup

Check to make sure the Voltage Selector Switch on the rear panel agrees with the power source available (Depending on the power source the switch positions should be in the up or down positions as shown).

**WARNING**

NEVER TOUCH THE TEST LEADS IN ANY MANNER (this includes insulation on all wires and clips) WHEN THE HIGH CURRENT IS APPLIED AND RED **DANGER** LIGHT IS **ON**.

USE ALL PRECAUTIONS NECESSARY TO AVOID TOUCHING THE DEVICE UNDER TEST WHEN THE RED **DANGER** LIGHT IS **ON** OR FLASHING.

Before connecting the instrument to its power source the **interlock function** on the rear panel remote connector must be properly utilized (jumper terminal 4 to 5) **This is an important safety feature for the protection of the operator.** Turn on of the instrument's high current is inhibited with no interlock connection and is functional with the interlock jumper in place (as shipped from the factory).

Connect the instrument power cord to the source of proper voltage. **The instrument is to be used only with three wire grounded outlets.**

Power is applied to the Sentry 50 by pressing the [POWER] button on the front panel.

**WARNING**

DO NOT TURN INSTRUMENT POWER ON OR OFF WITH TEST DEVICES CONNECTED.

On power-up the unit indicates the model number on the measure display (S 50) and is automatically set for those test conditions when the unit was last powered down.

## 2.2 Instrument Zeroing/Offset

The Sentry 50 provides automatic zeroing/offset for lead or fixture effects. During the zeroing/offset process a correction is made (subtracted out) and stored in instrument memory to be applied to ongoing measurements. For maximum measurement accuracy it is recommended that the unit be zeroed after power-up and any time the test leads or fixture is changed. **The instrument should warm-up for at least 15 minutes before zeroing.**

Proceed as follows for automatic zeroing/offset:

- Plug the G15 Lead Set (or other lead set/fixture) into the front panel Drive and Sense connectors as illustrated in Figure 2-1. Configure the leads or fixture for a short circuit (for G15 lead set, alligator clips shorted together) or (for G13, G14, G16, connect Sense + and Drive + leads to the power line ground pin of the power receptacle).
- With the instrument in the power-up state, Press [ENTER] key twice.
- Press [UP ▲] key once, display should read **OFSt** and **GEt**, **oFF** or **on**.
- Press [UP ▲] or [DOWN ▼] key to display **OFSt** and **GEt**.
- Push the [START] button to initiate the automatic storage of the offset value.
- The offset function will remain **on** until turned off by pressing the [ENTER] key twice, the [UP ▲] key once and the [UP ▲] or [DOWN ▼] key to **off**. If the instrument is powered down with the offset on it remains in effect when the unit is again powered up.

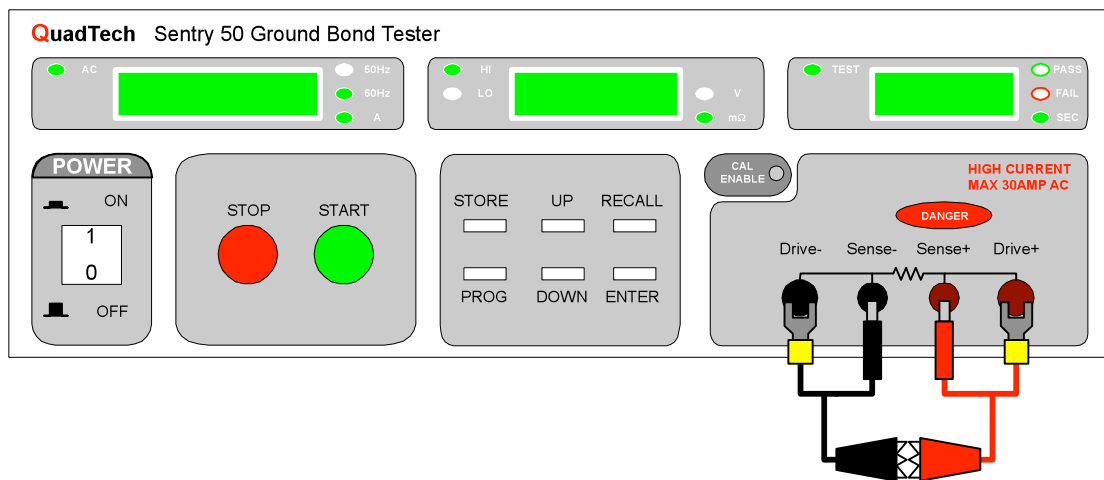

Figure 2-1: Connection for Offset Function



### 2.3 Connection to Device Under Test

Before connecting to the test device **press the [STOP] key** and make sure the red **DANGER** light is **not** on.

Connect the black leads of the G15 Lead Set to the front panel connectors (lug terminal to Drive- and banana plug to Sense-). Connect the red leads of the G15 Lead Set to the front panel connectors (lug terminal to Drive+ and banana plug to Sense+). When connecting the lug, rotate the outer portion of the black or red Drive connectors counter clockwise (ccw) to loosen, install lug and rotate clockwise (cw) to secure. Refer to Figure 2-2.

Connect the black alligator clip (Drive/Sense-) to one side of the device under test and the red alligator clip (Drive/Sense+) to the other side of the device under test.

**WARNING**  
NEVER TOUCH THE RED AND BLACK TEST LEADS WHEN THEY ARE CONNECTED TO THE INSTRUMENT AND THE RED **DANGER** LIGHT IS **ON** OR FLASHING.

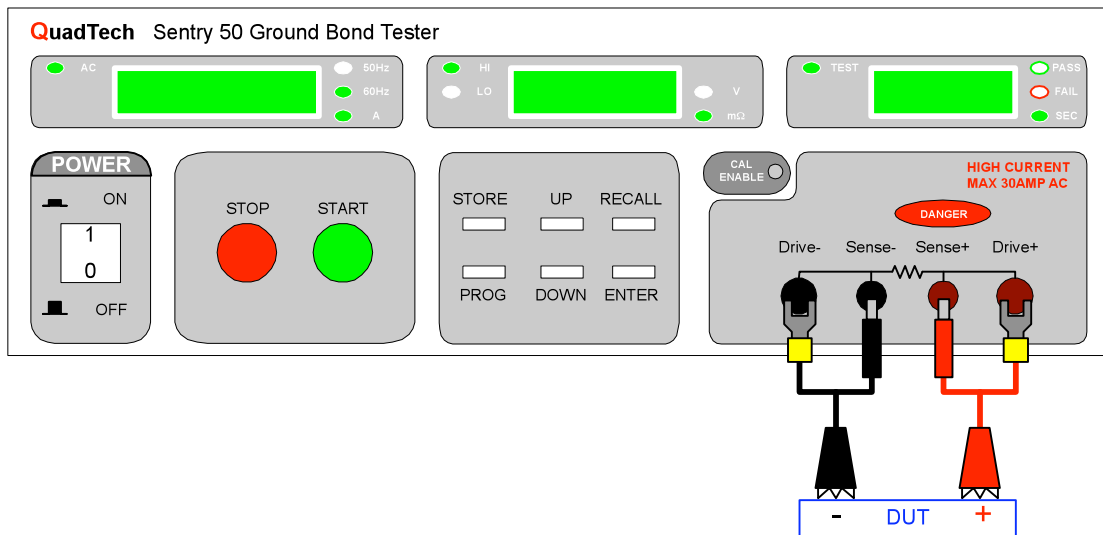

Figure 2-2: Connection to Device Under Test

## 2.4 Measurement Procedure

Once the instrument has been powered up, the offset function implemented and the device under test connected, testing can begin. The operator has the choice of performing a test at **power-up conditions** (test conditions at which the instrument was last powered down), or recalling one of 10 possible **stored setups**. Refer to paragraph 2.6 for instructions to change the test conditions.



**Figure 2-3: Instrument Control Keys**

**To initiate a test proceed as follows:**

- Press [**STOP**] (red button) to place the instrument in its standby ready-to-test state.
- Press [**START**] (green button) to start the test. When this button is pressed the high current is turned on. This is indicated by the DANGER light being on to warn the operator that high current is present at the test leads. The current display will indicate the current value, the measure display will indicate resistance value\* and the timer will show a countdown (time remaining).

\*When measurement is in progress [UP ▲] or [DOWN ▼] key will scroll between resistance or voltage display.

- Depending on the test conditions, the test current will cut off if a resistance limit is exceeded or cut off when the test time has expired. In the case of a FAIL situation the [**STOP**] button must be pressed to stop the beeper (when beeper is activated).
- The [**STOP**] button can be pressed at any time to stop the test and terminate current to the output terminals.

The display as illustrated in Figure 2-4 indicates the unit has exceeded the upper measurement limit for resistance.

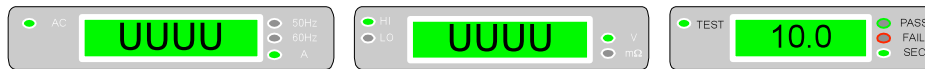

**Figure 2-4: Over Range Display**

**To recall one of the ten setups proceed as follows:**

- Press the [RECALL] key.
- Arrow [UP ▲] or arrow [DOWN ▼] to the setup number desired.
- Press [ENTER] to load the stored test conditions and then initiate a test as just described.

## 2.5 Programming Sequential Tests

A ground bond test can consist of one (**the most common mode of operation**) or two steps in sequence (two individual tests with programmed test conditions independent from the other).

To select step 1 or 2:

- With the instrument in standby status ([STOP] button previously pressed and no lights flashing) press the [UP ▲] key to select or examine step 1 and the [DOWN ▼] key for step 2. **For a single step test, the test current for step 2 must be set to 0.00, setting the test current for step 1 to 0.00 will inhibit all testing.** To change a test mode select the step to be changed (1 or 2) as described above and press [PROG] (the AC light will be flashing).
- Once the desired test step has been selected refer to paragraph 2.6 for changes to test conditions.

## 2.6 Programming Test Parameters

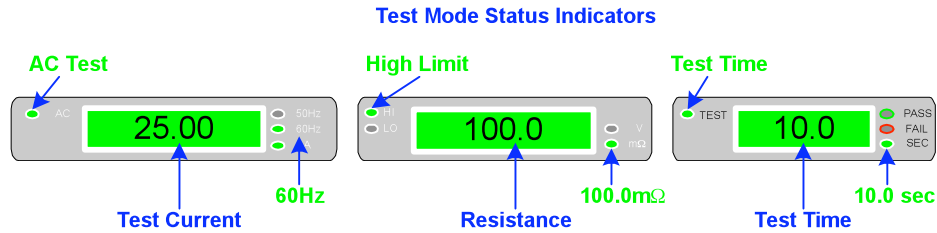

**Figure 2-5: Test Parameters**

With the instrument in standby status ([STOP] button previously pressed and no lights flashing) press the [UP ▲] key or [DOWN ▼] key to select the test step to be programmed, refer to paragraph 2.5 (UP arrow is step #1 and DOWN arrow step #2).

Press [PROG] key to begin the parameter change. The AC indicator will flash. Press the [ENTER] key to change the test current.

### Test Current

Press the [UP ▲] key or [DOWN ▼] key until the desired value is shown on the display and then press [ENTER]. (1.00 to 30.00 is the allowable range)

### 50 or 60 Hz

Press the [UP ▲] key or [DOWN ▼] key for 50Hz or 60Hz and then press [ENTER].

### Hi Limit

Press the [UP ▲] key or [DOWN ▼] key until the desired value in mΩ is shown on the display and then press [ENTER]. (0.1 to 510mΩ is the overall allowable range, with range dependent on the programmed current). Any measured value of resistance above this will result in a fail decision.

### Lo Limit

Press the [UP ▲] key or [DOWN ▼] key until the desired value in mΩ is shown on the display and then press [ENTER]. (0.0 to a value less than the Hi Limit is the allowable range). Any measured value of leakage current below this will result in a fail decision.

### Test Time

Press the [UP ▲] key or [DOWN ▼] key until the desired value in seconds is shown on the display and then press [ENTER]. (0.1 to 999 or 0.1 to 60 for programmed  $I > 25A$ , is the allowable range).

**WARNING**

EXTREME CAUTION MUST BE USED BY THE OPERATOR, IN CONTINUOUS MODE, HIGH CURRENT IS APPLIED TO THE TEST TERMINALS UNTIL THE STOP BUTTON IS DEPRESSED OR PROGRAMMED LIMITS ARE EXCEEDED.

After the final test condition entry the instrument returns to the blinking test mode (AC). Press **[PROG]** key to return to standby status, and thus ready for testing.

**To change the present set of test conditions:**

If test conditions are to be changed in the second step press the **[UP ▲]** key or **[DOWN ▼]** key to select the other step:

- set the test conditions for a second step as described in this paragraph (paragraph 2.6).

**To store the present set of test conditions proceed as follows:**

- Press the **[STORE]** key.
- Arrow **[UP ▲]** or arrow **[DOWN ▼]** to the setup number desired.
- Press **[ENTER]** to store the present test conditions.

## 2.7 Special Function Key Lock

In the key lock mode the program function (ability to change test conditions) of the instrument is disabled. It is however possible to recall any of the 10 setups and test. To activate or deactivate the key lock function proceed as follows:

- Instrument power should be off
- Press both the **[POWER]** and **[STOP]** switch at the same time and hold until the display indicates KEY LOCK, On or OFF. Arrow **[UP]** or **[DOWN]** to select the desired state and press **[ENTER]**.

## 2.8 Software Version Display

The version of software, installed in the instrument, can be displayed on the front panel.

### To display software version:

- Press the front panel [POWER] switch to **ON** and **immediately** press the [ENTER] key. The year will be shown in the left display and the month and day in the right display as illustrated below. This software version display is only held for a couple of seconds.

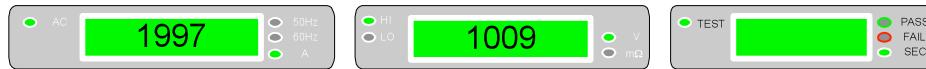

Figure 2-6: Software Version Display

## 2.9 Clear Setup Memory

All stored test conditions in instrument memory (10 setups) can be cleared with a few key strokes.

### To clear setup memory:

- With the instrument in standby status ([STOP] button previously pressed and no lights flashing) press the [ENTER] key three times and then the [UP ▲] key. Display should read **clr?**
- Press [ENTER] to clear memory. Press any key other than [ENTER] to cancel.

## 2.10 Fail Continuous Mode

When activated the Sentry 50 provides a continuous test mode where the test current does not shut down on a fail condition.

### WARNING

THIS MODE IS NOT RECOMMENDED AS A NORMAL OPERATING MODE. (On the remote control connector, one FAIL contact must be connected to START and the other FAIL contact connected to COM)

Proceed as follows for fail continuous mode on or off:

- With the instrument in the power-up state, Press [ENTER] key three times.
- Press [DOWN ▼] key once, display should read **FAIL Cont** and **OFF** (unless already selected for on).
- Press [UP ▲] or [DOWN ▼] key to display **ON**.

- To exit the fail continuous setup mode press **[ENTER]** three times (exits through the Beep On/Off setup mode and the Output Voltage setup mode)
- The fail continuous mode will remain on until turned off by pressing the **[ENTER]** key three times, the **[DOWN ▼]** key once and the **[UP ▲]** or **[DOWN ▼]** key to **OFF**. If the instrument is powered down with fail continuous on it remains in effect when the unit is again powered up. Fail continuous mode is not stored as part of test setups.

## 2.11 Beeper Setup Mode

When activated the Sentry provides a beep or audible sound for pass/fail indication and also when any one of six data entry key is depressed.

Proceed as follows for beeper on or off:

- With the instrument in the power-up state, Press **[ENTER]** key three times.
- Press **[DOWN ▼]** key once, display should read **FAIL Cont** and **On** or **OFF**. Press **[ENTER]** key once again and display should read **bEEP** and **Off** (unless beep is already selected for On).
- Press **[UP ▲]** or **[DOWN ▼]** key to display **ON**.
- To exit the beep setup mode press **[ENTER]** two times (exits through the Output Voltage setup mode)
- The beeper will remain on until turned off by pressing the **[ENTER]** key three times, the **[DOWN ▼]** key once, the **[ENTER]** key and then the **[UP ▼]** or **[DOWN ▼]** key to **OFF**. If the instrument is powered down with beeper on it remains in effect when the unit is again powered up. The beeper setup is not stored as part of test setups.

## 2.12 Voltage Limit

The voltage limit (open circuit) is programmable from 6.0 to 15 VAC in 0.1 V steps.

Proceed as follows to change the voltage limit:

- With the instrument in the power-up state, Press **[ENTER]** key three times.
- Press **[DOWN ▼]** key once, display should read **FAIL Cont** and **On** or **OFF**. Press **[ENTER]** two times again and display should read **Out** and **Volt** and voltage limit setting.
- Press **[UP ▲]** or **[DOWN ▼]** key until the desired value is shown on the display and then press **[ENTER]**.
- The voltage limit will remain as programmed until changed as described above. The voltage limit is stored as part of test setups.

Note: When measurement is in progress **[UP ▲]** or **[DOWN ▼]** key will scroll between resistance or voltage display.

## 2.13 Remote Control

Two remote control connectors are located on the rear panel of the instrument with input connections for starting and stopping the unit externally and output connections indicating instrument status and a safety interlock connection. Inputs require a contact closure and outputs provide a contact closure, as illustrated in the Figure 2-7.

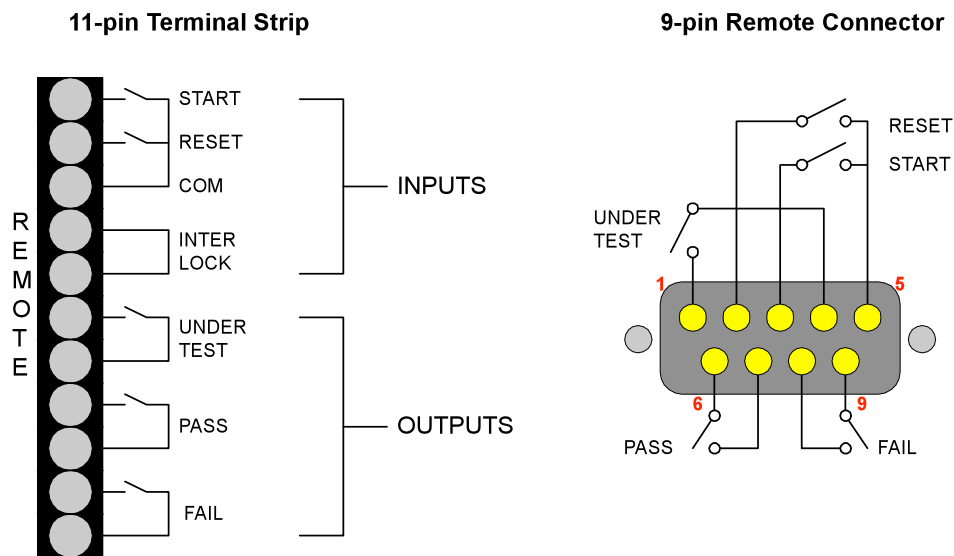

Figure 2-7: Rear Panel Remote Connectors



Figure 2-8 illustrates the timing diagram for remote operation of the Sentry 50 Ground Bond tester.

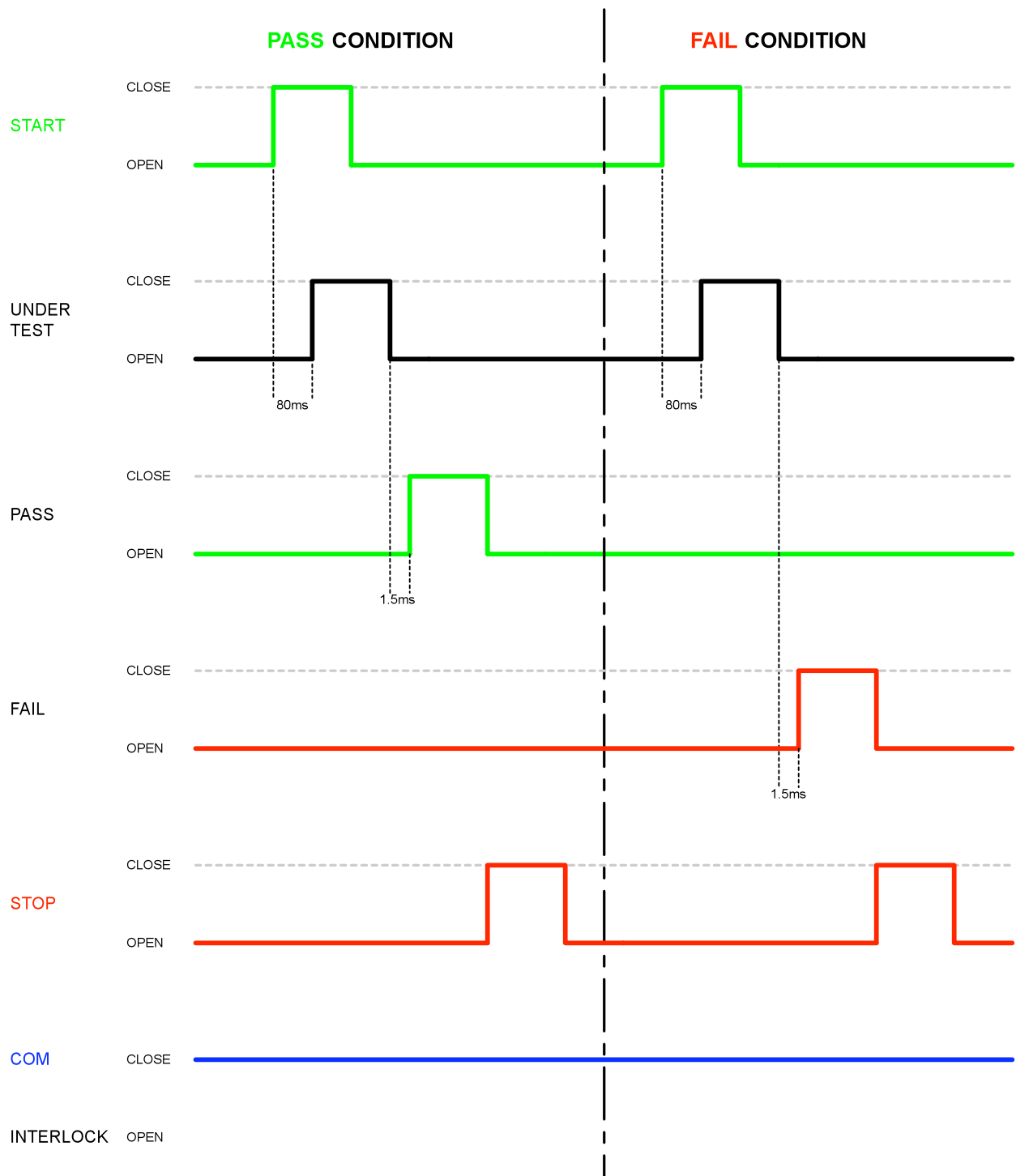

Figure 2-8: Timing Diagram

## 2.14 Use with Sentry 10/20/30 or 15/25/35

The Sentry 50 can be connected to a Sentry 10/15, 20/25 or 30/35 for complete product testing (ground bond and hipot) with the push of one button. When the Sentry 50 completes a test with a pass indication it can remotely start the Sentry 10/20/30 hipot Tester.

**WARNING**  
MAKE SURE INSTRUMENT POWER IS TURNED OFF WHEN CONNECTING OR DISCONNECTING  
CABLES AND LEADS.

### Interconnection using S15 Cable Set:

- Connect the 9-pin interconnect cable between the rear panel remote connectors on each instrument (cable end marked S50 to the Sentry 50 and cable end marked S10 to the Sentry 10/20/30).
- Connect the banana to banana cable between the **Drive** banana plug (black) on the front of the Sentry 50 and the **GND** banana plug (black) on the Sentry 10/20/30.

### Connection to device under test:

- Refer to operation section of the Sentry 50 or Sentry 10/20/30 instruction manual for connection to the device under test.

### Test procedure:

- Once S15 Cable Set is connected, follow the proper power up/down procedure: **TURN SENTRY 50 ON FIRST AND SENTRY 10/20/30 OFF FIRST.**
- With test conditions for the Sentry 50 and Sentry 10/20/30 programmed, press **START** on the Sentry 50 to initiate both tests.
- After initiating a measurement the stop button on the Sentry 50 must be pressed before programming test conditions on the Sentry 10/20/30 again.

**NOTE:**  
When performing zero offset with these units, the device under test (DUT) must be disconnected from the G13 and the G15 cable connected to the ground on the G13.

Figure 2-9 illustrates the connection of the Sentry 50 Ground Bond Tester to a Sentry 35 Hipot Tester and a G13 Corded Product Adaptor.

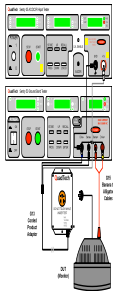

**Figure 2-9: Interconnection with G13 Corded Product Adaptor**

**NOTE:**

When performing zero offset with these units, the device under test (DUT) must be disconnected from the G13 and the G15 cable connected to the ground on the G13.

## 2.15 G16 International Power Strip

The G16 International Power Strip allows connection of standard corded products from several different countries. These being:

- |                 |                  |               |
|-----------------|------------------|---------------|
| * Australia     | * United Kingdom | * Denmark     |
| * North America | * Norway         | * Finland     |
| * Sweden        | * Germany        | * Netherlands |
| * Austria       | * Switzerland    | * Italy       |

Refer to Figure 2-10 for connection of the G16 International Power Strip to the Sentry 50 Ground Bond Tester.

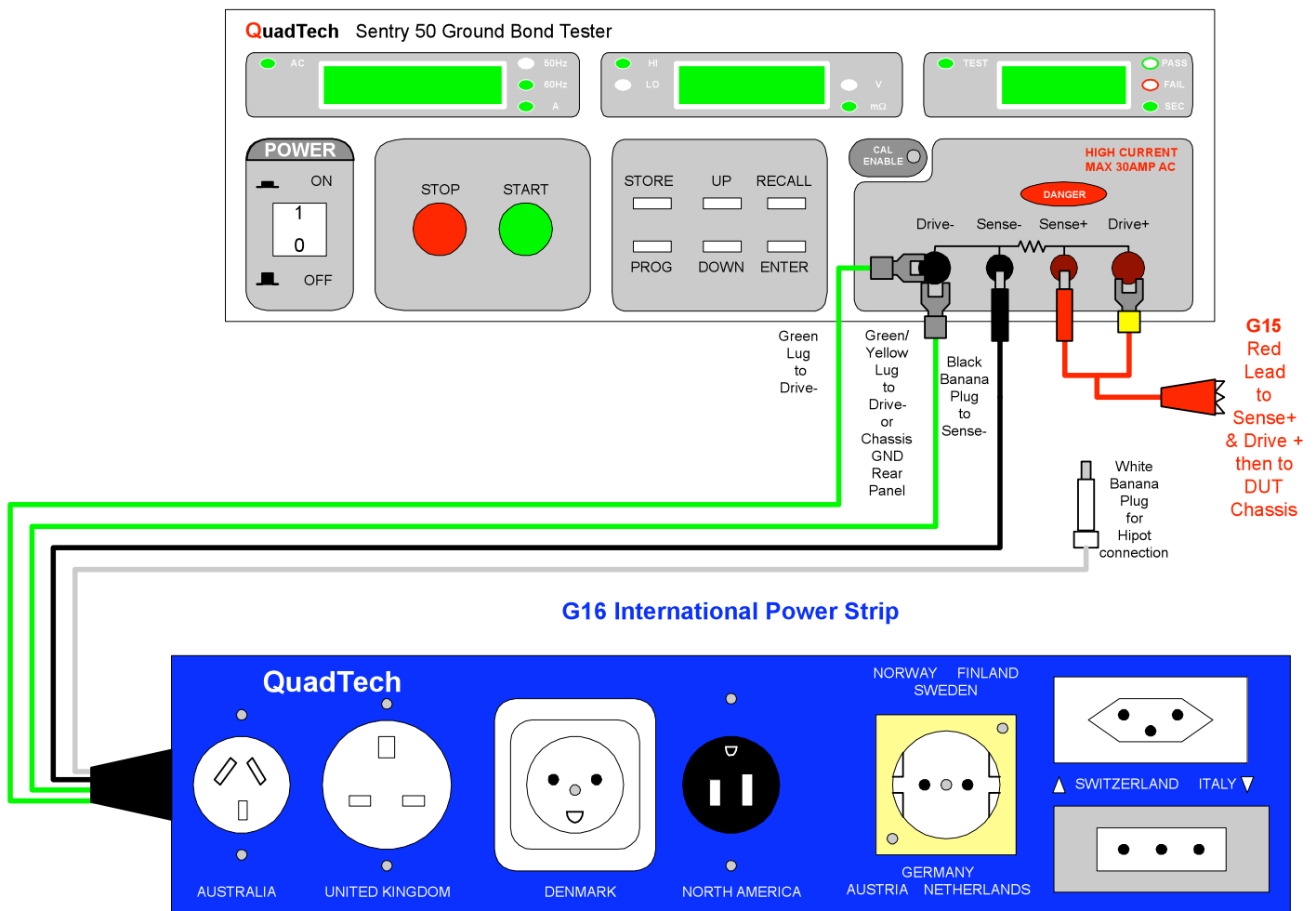

Figure 2-10: G16 International Power Strip Connection

---

## Section 3 : Service & Calibration

---

### 3.1 General

Our warranty (at the front of this manual) attests to the quality of materials and workmanship in our products. If malfunction should be suspected or other information be desired, applications engineers are available for technical assistance. Application assistance is available in the U.S. by calling 800-253-1230 and asking for Applications Support. For support outside of the United States, please contact your local [QuadTech Distributor](#).

### 3.2 Instrument Return

Before returning an instrument to QuadTech for [Service](#) please obtain an [online Return Materials Authorization Number \(RMA#\)](#). This number, when placed on the outside of the shipping package, will speed processing at our Service Lab and will serve as a reference number for the time your unit is at QuadTech. Please contact our **Customer Care Center (CCC)** at **800-253-1230** for additional support. The CCC phone line is staffed from 8:00am to 5:00pm (EST).

It will be necessary to include a Purchase Order Number and credit card information to insure expedient processing, although units found to be in warranty will be repaired at no-charge. For any questions on repair costs or shipment instructions please contact our CCC Department at the above number. To safeguard an instrument during storage and shipping please use packaging that is adequate to protect it from damage, i.e., equivalent to the original packaging and mark the box "Delicate Electronic Instrument". Please follow online instructions for shipping materials back to QuadTech.

### 3.3 Calibration

#### 3.3.1 Calibration Equipment

Table 3-1 lists the equipment necessary to calibrate a Sentry 50 Ground Bond Tester.

**Table 3-1: Equipment for Calibration**

Description	Requirements
AC Voltmeter	Measure Range: 0-10V, 0.1%; Fluke 8842A, Keithley 2000 or equivalent
Current Shunt	1 m $\Omega$ 4-Terminal, 50mV, 50A; Deltec Co., Norwalk, CA 90650
Current Shunt	10 m $\Omega$ 4-Terminal, 0.25% at 10A, 20A & 30A
Current Shunt	100 m $\Omega$ 4-Terminal, 0.25% at 10A, 20A & 30A

### 3.3.2 Calibration Procedure

Allow the Sentry 50 instrument to warm up for a minimum of 30 minutes.

1. Using a pen point or small screwdriver, depress the **[CAL ENABLE]** switch on the front panel. (Note, this is a push-push switch. To disable CAL, merely push the switch a second time).
2. Press **[ENTER]** four times.
3. Press **[DOWN]** until display reads "CAL TEST". Note **[DOWN]** can be continuously cycled between "CAL OFF", "CAL ON", and "CAL TEST".
4. With "CAL TEST" displayed, press **[PROG]** to select test.

#### 3.3.2.1 AC Offset Current Calibration

Connect the Sentry 50 instrument as shown in Figure 3-1.

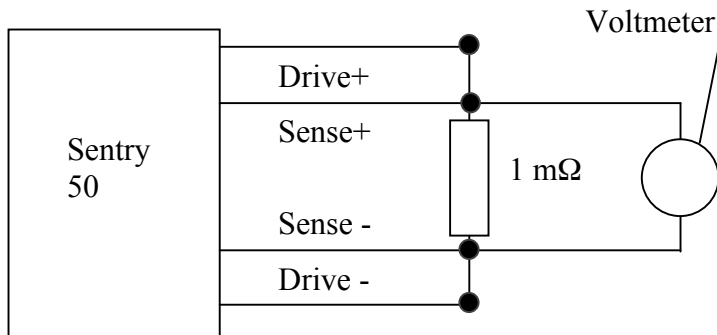
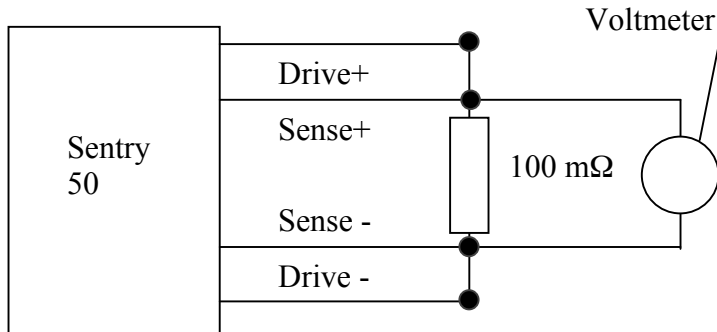

**Figure 3-1: Connection for AC Offset Current**

5. Unit will display "3.00 OFSt GrA". This is the first of the parameters which must be calibrated.
6. Press **[PROG]**. Unit will display "AC 3.00A 200.0mΩ 0.0SEC".
7. Press **[STOP]**, **[START]**. Note the measurement readout on the unit and press **[UP]**, **[DOWN]** until this reading agrees with the voltage reading on the voltmeter. For example: if the voltmeter reads 3.413 mV use the UP/DOWN keys to make the Sentry 50 read the same (3.413).
8. Press **[ENTER]** to save the calibration data.
9. Press **[STOP]** to end the offset calibration.

### 3.3.2.2 AC Full Current Calibration

Connect the Sentry 50 instrument as shown in Figure 3-2.

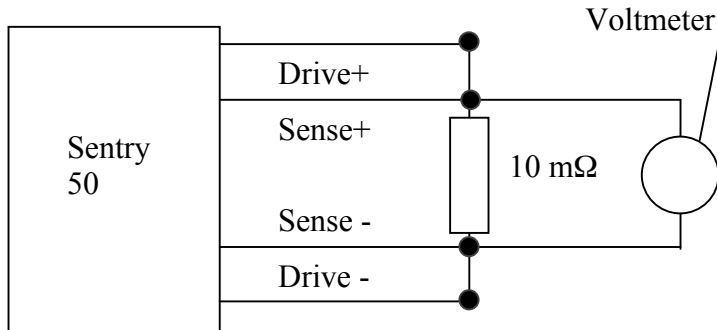

**Figure 3-2: Connection for AC Full Current**

10. Press **[DOWN]** to select full scale current. Unit will display “25.00 FULL GrA”.
11. Press **[PROG]**. Unit will display “AC 25.00A 200.0mΩ 0.0SEC”.
12. Press **[STOP]**, **[START]**. Note the measurement readout on the unit and press **[UP]**, **[DOWN]** until this reading agrees with the voltage reading on the voltmeter. For example: if the voltmeter reads 27.58 mV use the UP/DOWN keys to make the Sentry 50 read the same (27.58).
13. Press **[ENTER]** to save the calibration data.
14. Press **[STOP]** to end the full scale calibration.

### 3.3.2.3 AC Offset Voltage Calibration

Connect the Sentry 50 instrument as shown in Figure 3-3.



**Figure 3-3: Connection for AC Offset Voltage**

15. Press **[DOWN]** to select grounding voltage offset. Unit will display "5.00 OFSt GrV".
16. Press **[PROG]**. Unit will display "AC 5.00A 200.0mΩ 0.0SEC".
17. Press **[STOP]**, **[START]**. Note the measurement readout on the unit and press **[UP]**, **[DOWN]** until this reading agrees with the voltage reading on the voltmeter. For example: if the voltmeter reads 0.061V use the UP/DOWN keys to make the Sentry 50 read the same (0.061).
18. Press **[ENTER]** to save the calibration data.
19. Press **[STOP]** to end the full scale calibration.



### 3.3.2.4 AC Full Voltage Calibration

Connect the Sentry 50 instrument as shown in Figure 3-4.

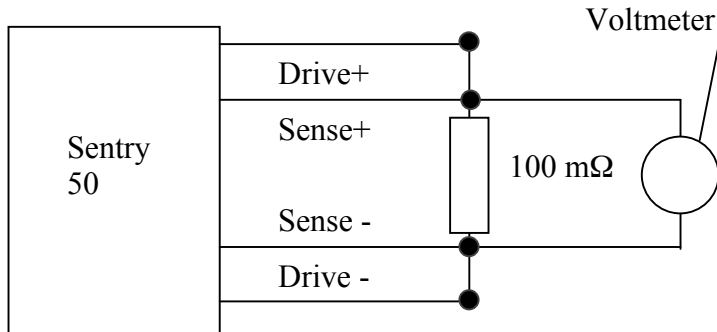

**Figure 3-4: Connection for AC Full Voltage**

20. Press **[DOWN]** to select grounding voltage full scale. Unit will display "30.00 FULL GrV".
21. Press **[PROG]**. Unit will display "AC 30.00A 200.0mΩ 0.0SEC".
22. Press **[STOP]**, **[START]**. Note the measurement readout on the unit and press **[UP]**, **[DOWN]** until this reading agrees with the voltage reading on the voltmeter. For example: if the voltmeter reads 2.980V use the UP/DOWN keys to make the Sentry 50 read the same (2.980).
23. Press **[ENTER]** to save the calibration data.
24. Press **[STOP]** to end the full scale calibration.
25. Press **[ENTER]** four times.
26. Press **[DOWN]** until display reads "CAL ON". Note **[DOWN]** can be continuously cycled between "CAL OFF", "CAL ON", and "CAL TEST".
27. With "CAL ON" displayed, press **[PROG]** to complete calibration. Again, using a pen point or small screwdriver, depress the **[CAL ENABLE]** switch on the front panel and release.