

Model 73094

Top Loading Binding Posts, Quick Wire Attachment

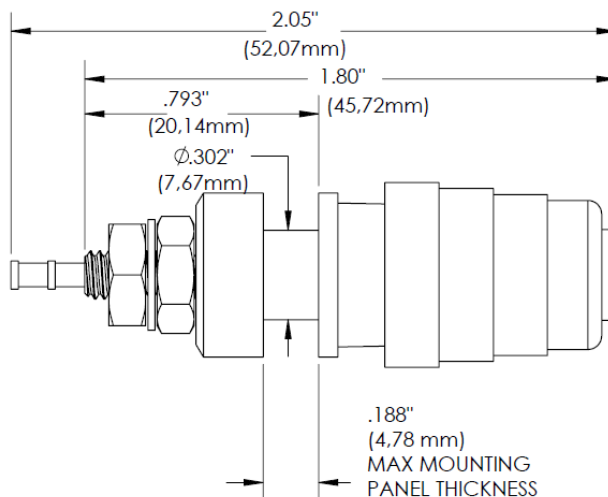

Features

- Secure wires quickly; simply, pull and hold down the top of the binding post, insert wire into the opening, and release the top of the binding post to secure your connection
- Mounts are a #8 hole
- Max mounting panel thickness of 0.188" (4,78mm)
- Use up to 15 AWG wire gauge
- Great for any applications where a standard 5-Way or Spring Loaded Binding Post are used

Materials

Body: Nickel-plated brass
 Insulation: Valox (UV and fire resistant)

Specifications

Voltage	33 V AC / 70 V DC, *1000 V
Max Current	15 A
*Maximum voltage for hands free use: 1000 V. Do not use on circuits where transient stresses can exceed the rated voltage	

Ordering Information

Model: 73094-*color*
Color: 0=Black, 2=Red
 Top Loading Binding Post, Quick Wire Attachment

USA: Sales: 800-490-2361
 Technical Support: technicalsupport@pomonatest.com
 Fax: 425-446-5844
Europe: 31-(0) 40 2675 150 **International:** 425-446-5500
Where to Buy: www.pomonaelectronics.com

All dimensions are in inches. Tolerances (except noted): .xx = ±.02" (.51 mm), .xxx = ± .005" (.127 mm). All specifications are to the latest revisions. Specifications are subject to change without notice. Registered trademarks are the property of their respective companies.