

**Model 6481
Test Connector Adapter Set**

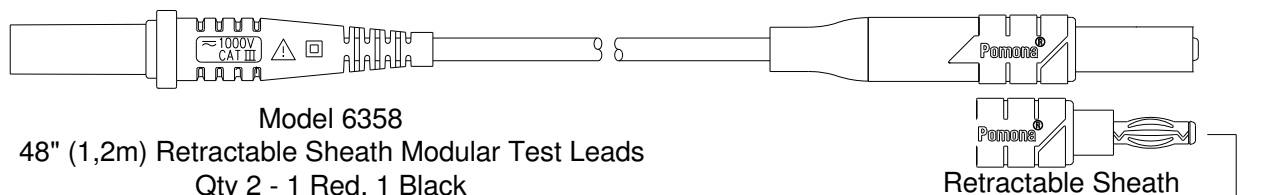

Model 6358
48" (1,2m) Retractable Sheath Modular Test Leads
Qty 2 - 1 Red, 1 Black

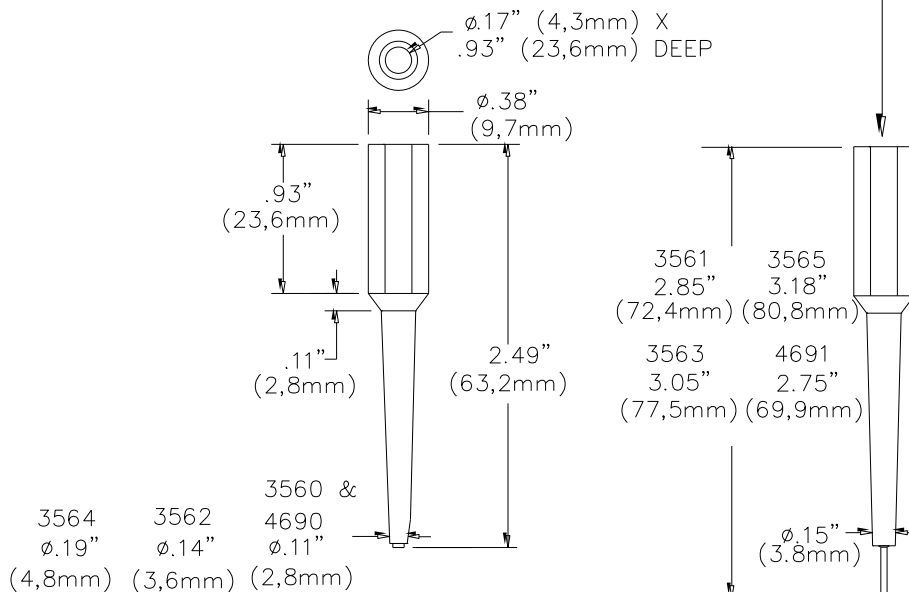

Features

- 18-piece kit includes one red and one black set of each pin & socket size along with a set of 48" (1,2m) red and black test leads.
- Test adapters are ideal for rapid testing of the hard-to-get at contacts of multi-pin/socket connectors.
- Round pins and socket adapters.
- Flexible tip allows testing of adjacent contacts.
- Full insulation protects against shorting or contact damage.
- Test leads feature high strand count silicone wire for extreme flexibility and high temperature resistance.
- Model 4690 also fit 0.025in (0.63mm) sq. pins.

Model	Contact Size	Type	Current
4690	22 AWG .030"	Socket	3 Amps
4691	(.76mm)	Pin	
3560	20 AWG .040"	Socket	
3561	(1.02mm)	Pin	
3562	16 AWG .063"	Socket	
3563	(1.60mm)	Pin	
3564	12 AWG .093"	Socket	
3565	(2.36mm)	Pin	

Voltage Rating:

For *CE compliance* and for personal safety, do not hold in hand when voltages exceed 30 Vrms/42.4 Vpk/60 Vdc or current exceeds 8A maximum. Maximum voltage for *hands free use*: 1000Vrms. Do not use on circuits where transient stresses can exceed the rated voltage.

USA: Sales: 800-490-2361
Technical Support: technicalsupport@pomonatest.com
Fax: 425-446-5844

Europe: 31-(0) 40 2675 150 **International:** 425-446-5500
Where to Buy: www.pomonaelectronics.com

All dimensions are in inches. Tolerances (except noted): .xx = ±.02" (.51 mm), .xxx = ±.005" (.127 mm). All specifications are to the latest revisions. Specifications are subject to change without notice. Registered trademarks are the property of their respective companies.

Model 6481
Test Connector Adapter Set**Materials****Models: 3560, 3562, 3564 & 4690**

Insulation: Polyvinyl chloride (PVC)
Banana Jack Body (upper connector)
Material: Brass.
Finish: Bright Tin plated
Socket (lower connector):
Material: Copper Alloy
Finish: Gold over copper plate

Models: 3561, 3563, 3565 & 4691

Insulation: Polyvinyl chloride (PVC).
Banana Jack Body (upper connector)
Material: Brass.
Finish: Bright Tin plated
Pin (lower connector):
Material: Brass
Finish: Gold plated over electroless nickel.

Model: 6358 Test Leads (male to male)

Straight Sheath Banana Plug:

Insulation: Polypropylene, Color: One Black, One Red

Retractable Sheath Banana Plug:

Compression Spring: Stainless Steel*Tip:* Nylon, Color matches Color of Wire*Insulation:* Polypropylene Molded to the Plug and Wire. Color Matches Color of Wire.*Plug Body:* Brass, Nickel Plated*Banana Spring:* Beryllium Copper, Nickel Plated*Wire:* 18 AWG, 192 x 41 bare copper, Silicone Insulation, O.D. 0.144" (3,66mm), Color: One Black, One Red**Ratings****Models: 3560, 3562, 3564, 4690, 3561, 3563, 3565 & 4691 only**

Operating Voltage: For *CE compliance* and for personal safety, do not hold in hand when voltages exceed 30 Vrms/42.4 Vpk/60 Vdc. Maximum voltage for hands free use: 2500 Vrms Max. Do not use on circuits where transient stresses can exceed the rated voltage.

Operating Temperature: +55°C (+131°F) Max.

(6358* only):

Conforms to IEC 61010-031

Operating Voltage: CAT III 1000V

Operating Temperature: +55°C (+131°F) Max.

Current: 10 Amperes

* *Connectors with retractable insulation sleeves are only for connection to equipment that is NOT provided with terminals which accept fully insulated connectors. These connectors provide NO PROTECTION against electric shock. DO NOT use connectors with retractable insulation sleeves with hand-held probes.*

Ordering InformationModel: **6481**

Kit contains one red and one black adapter of each model: 3560, 3561, 3562, 3563, 3564, 3565, 4690, 4691 and one set of Model 6358 test leads.

USA: Sales: 800-490-2361
Technical Support: technicalsupport@pomonatest.com
Fax: 425-446-5844

Europe: 31-(0) 40 2675 150 **International:** 425-446-5500

Where to Buy: www.pomonaelectronics.com

All dimensions are in inches. Tolerances (except noted): .xx = ±.02" (.51 mm), .xxx = ±.005" (.127 mm). All specifications are to the latest revisions. Specifications are subject to change without notice. Registered trademarks are the property of their respective companies.