

FEATURES:

- Connector accepts types 58, 58C, 58A, 141, 141A

MATERIALS:

Body and fittings - Brass

Center Contact - Brass

Outer Contact – Beryllium Copper

Gasket – Silicone rubber

Dielectric – Teflon

Finish: Body and Fittings – Tarnish Resistant

Center Contact – Gold plated

Outer contact – Tarnish Resistant

Marking: “POMONA ELECT. 5285” located approximately as shown.

RATINGS:

Operating Voltage: 500 VRMS Max.

Nominal Impedance: 50 Ohms

ORDERING INFORMATION: Model 5285

All dimensions are in inches and metric. All specifications are to the latest revisions. Specifications are subject to change without notice.
Registered trademarks are the property of their respective companies. Made in USA

Sales: 800-490-2361 Fax: 888-403-3360
Technical Assistance: 800-241-2060

PomonaACCESS 90117 (800) 444-6785 or (425) 446-6010
More drawings available at www.pomonaelectronics.com

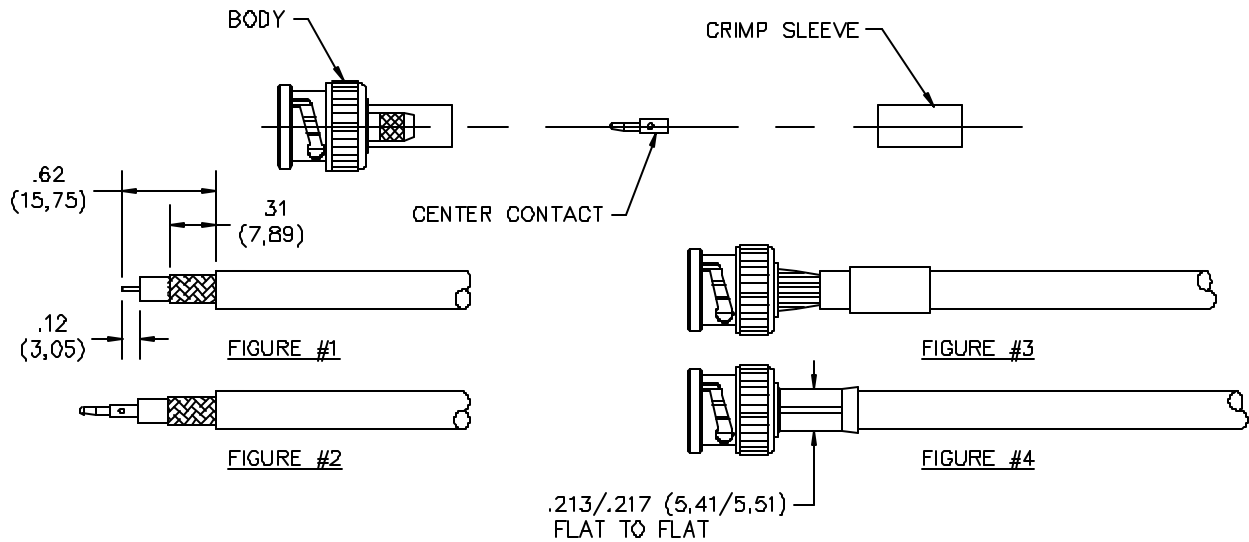

FIGURE #1

A. Strip cable as shown.

FIGURE #2

B. Fit the center contact over conductor wires, slide until it butts against the dielectric. Crimp or solder.

FIGURE #3

C. Slide the metal crimp sleeve over cable, then install the connector body until contact locks into connector.
D. Verify that the knurled ferrule of connector is inserted between the dielectric and the braid.

FIGURE #4

E. Slide the metal sleeve along the cable unit until it butts against the bottom of connector.
F. Crimp sleeve using Hex type Die or equivalent.
G. Retention after crimp is normally 60 lbs./Minute.

Note: Hex Diameter .213/.217 after crimp.

All dimensions are in inches and metric. All specifications are to the latest revisions. Specifications are subject to change without notice.
Registered trademarks are the property of their respective companies. Made in USA

Sales: 800-490-2361 Fax: 888-403-3360
Technical Assistance: 800-241-2060

PomonaACCESS 90117 (800) 444-6785 or (425) 446-6010
More drawings available at www.pomonaelectronics.com