

Model 4590 Mounting Base, Triple Banana Jack For Standard Banana Jack

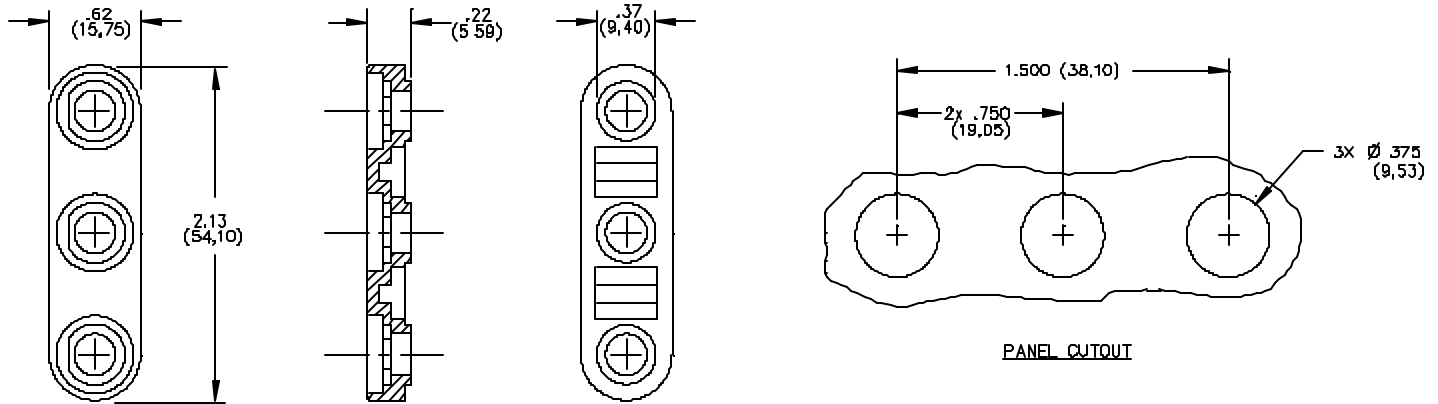

MATERIALS:

Body: Polycarbonate

Color: Black and Red

Marking : "Pomona Electronics Calif."

RATINGS:

Operating Temperature: +115° C. (+239° F.) Max.

ORDERING INFORMATION: Model 4590-*

*=Color, -0 Black, -2 Red

Ordering Example: 4590-2 Mounting Base Color is Red

Parts are packaged ten (10) per bag.

For use with Models 1581, 2854, 3267, 4005 and 4601.

All dimensions are in inches. Tolerances (except noted): .xx = ±.02" (.51 mm), .xxx = ± .005" (.127 mm).

All specifications are to the latest revisions. Specifications are subject to change without notice.

Registered trademarks are the property of their respective companies. Made in USA