



TEST

PHILIPS

Programmable Timer/Counter PM 6666

Operator's manual



Contents

SAFETY	3	GPIB-INTERFACE OPERATION	33
Introduction	4	What can I do using the bus?	34
Safety precautions	4	Connecting the controller	35
Caution & warning statements	4	Giving the counter an address	35
Symbols	4	Checking the communication	35
If in doubt about safety	4	Two ways of programming	36
PRODUCT PRESENTATION	5	Selecting output separator	37
Front view	6	How to select function	37
Rear view	6	Selecting Measuring-Time	38
INSTALLATION	9	Selecting Input settings	38
Unpacking	10	Totalize Start/Stop	39
Check list	10	Free-Run	39
Voltage-range selection	10	Service Request	40
Earthing	10	Status byte	41
Connecting external reference	10	Output mode	42
Installing options	11	Bus Learn	45
Introduction	11	Programming data out	46
Removing the cover	11	What happens when I switch to local?	46
HF-input	11	Summary of bus commands	47
MTCXO Time-base oscillator	12	Programming examples	48
GPIB-interface	12	For HP-85 controller	48
Battery unit	13	For IBM PC with PM 2201	49
Rack-mount kit	13	SPECIFICATIONS	53
OPERATING INSTRUCTIONS	15	Measuring functions	54
General	17	Definitions	55
Switching on	17	Input specifications	56
Timer/Counter settings after switching on	17	General information	57
Front panel logic	17	Auxiliary functions	58
Using the Timer/counter	18	Optional accessories	59
Operating the controls	18	Ordering information	61
Function and range	19	APPENDIX 1	
Hints and comments	19	Checking the sensitivity of counters	63
Battery unit	30	INDEX	65
Calibrating the MTCXO	30		
Error codes	31		



SAFETY

Introduction

Read this page carefully before you install and use the PM 6666 Timer/Counter.

This Timer/Counter has been designed and tested in accordance with IEC publication 348 and has been supplied in a safe condition. The user of this instrument must have the required knowledge of PM 6666. This knowledge can be gained by thoroughly studying this manual.

Safety precautions

Use generally-accepted safety procedures, in addition to the safety precautions stated in this manual, to ensure personal safety and safe operation of the Timer/Counter.

Caution & warning statements

You will find specific warning and caution statements, where necessary throughout the manual. Do not carry out repairs or adjustments to the Timer/Counter without reading the Service Manual, which contains the relevant warnings for such activities.

CAUTION: *indicates where incorrect operating procedures can cause damage to, or destruction of, equipment or other property.*

WARNING: *indicates a potential danger that requires correct procedures or practices in order to prevent personal injury.*

Symbols



Indicates where the protective ground lead is connected inside the instrument. Never unscrew or loosen this screw.

If in doubt about safety

Whenever you suspect that it is unsafe to use the instrument, you must make it inoperative, clearly mark it to prevent its further operation, and inform the Philips servicing department.

E.g. The instrument is likely to be unsafe if it is visibly damaged.

PRODUCT PRESENTATION

General

The PM 6666 is a compact, high resolution, reciprocal Timer/Counter which performs many functions. A number of options are available i.e. HF-input, GPIB-interface, high stability oscillator and rechargeable battery for field use.

A rack-mount kit and a carrying case are also available as accessories.

Front view

- A) Power switch.
- B) Reset button, doubles as Local button if the Timer/Counter is equipped with an GPIB interface. Starts and stops counting if the TOT A MAN function is selected.
- C) Measuring-time selector-button. *
- D) Function-selector button. *
- E) Display-hold button. Freezes the display.
- F) COM B via A button connects the signal on input A to input B. The Input-A attenuator and AC/DC switch affect both inputs.
- G) Input-C BNC-connector (optional).
- H) Input-A BNC-connector.
- I) Set value button, depress to set sensitivity (AC) or trigger level (DC).
- J) Auto level, starts automatic trigger level setting. If 'Set Value' is selected, this button is used to increase the value.
- K) Read level, displays trigger levels. If 'Set Value' is depressed, this button is used to decrease the value.
- L) Input-B BNC-connector.
- M) Trigger indicators.
- N) Attenuator buttons.
- O) Slope selection buttons.
- P) DC or AC coupling selection buttons.
- Q) Large LCD-display.
- R) Tilting support.

* The selected function is indicated on the display. A short press on the button moves the cursor one step to the right. A long press makes the cursor scroll.

Rear view

- S) Rear feet.
- T) Screws for removing the cover.
- U) External-reference-input, BNC connector.
- V) Voltage-range selector.
- W) Power-inlet socket.
- X) GPIB address-selector (option).
- Y) GPIB interface-connector (optional).

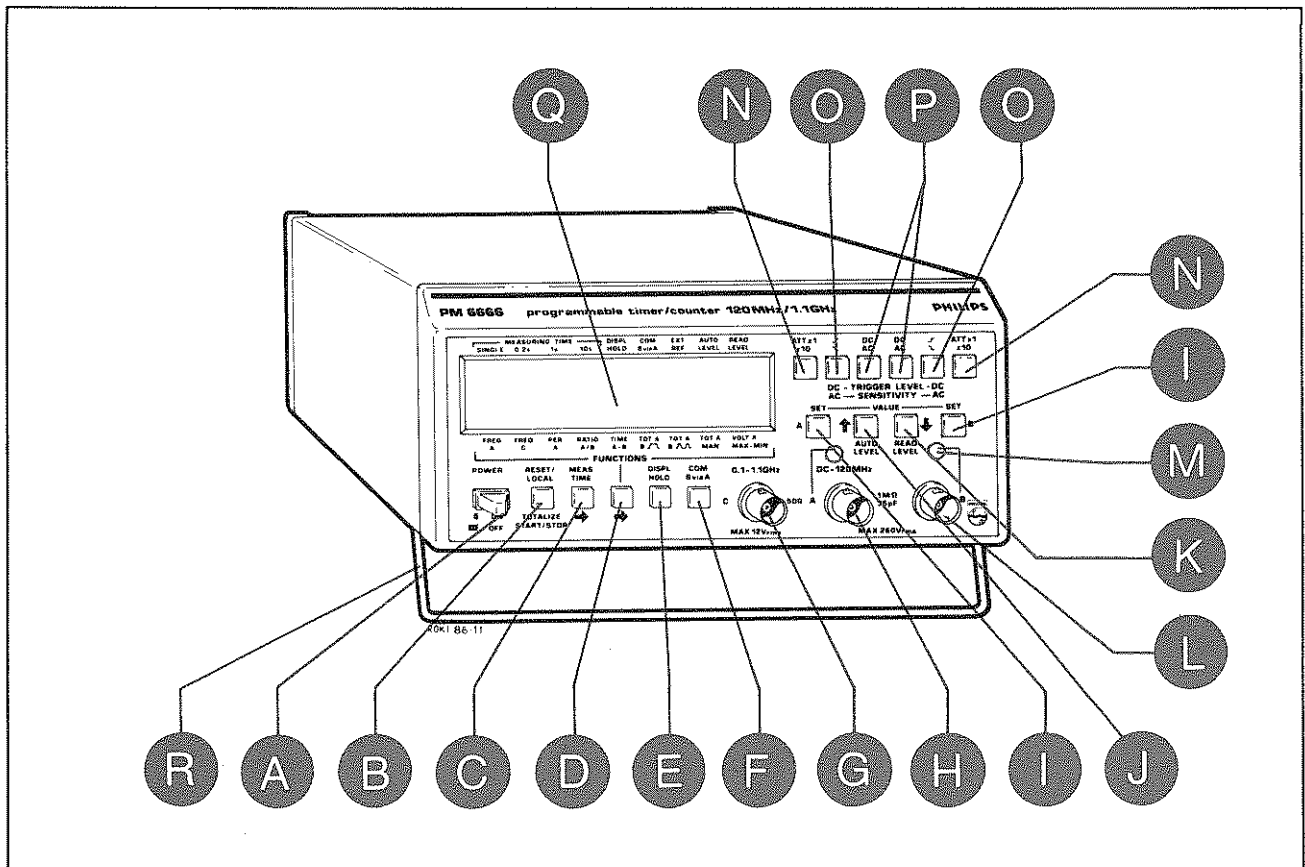

Figure 1. Front view.

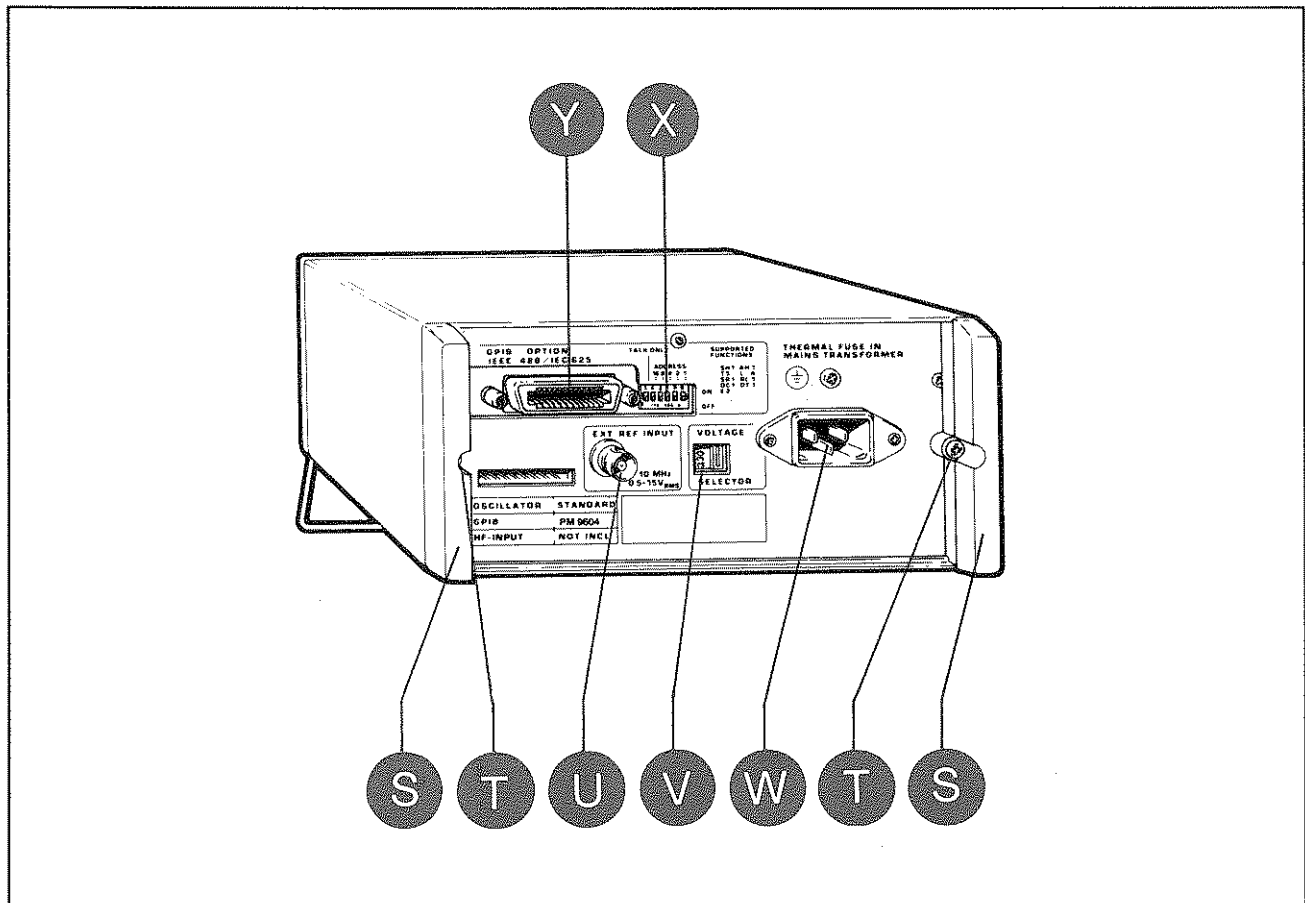

Figure 2. Rear view.

INSTALLATION

Unpacking

- If the Timer/Counter is cold, leave it in the cardboard box until it has reached normal room temperature.
- Lift the Timer/Counter out of the box.
- Remove the polystyrene supports.
- Unpack the Timer/Counter from the plastic bag.

Reverse the procedure to pack.

Check list

Has the Timer/Counter been damaged in transport? If it has, file a claim with the carrier immediately, and notify the Philips sales & service organization to make repair or replacement of the instrument easier.

Check that the package contains the following items in addition to the Timer/Counter:

- This Operators' Manual
 - A power cable with protective earth conductor
 - A Battery unit if ordered *)
 - An MTCXO oscillator if ordered *)
 - A GPIB interface if ordered *)
 - An HF-input if ordered *)
- *) Labels on the rear panel indicate which options are fitted in your Timer/Counter.

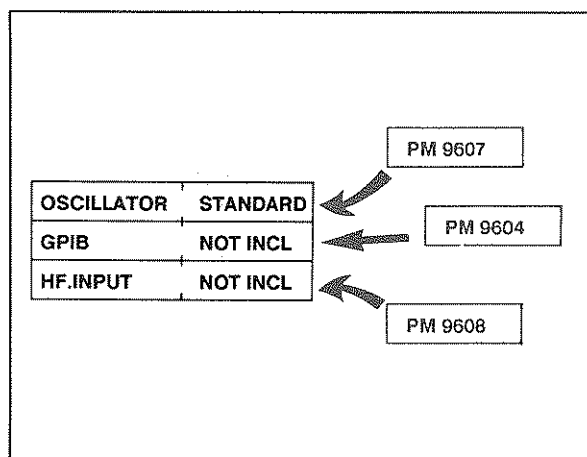

Figure 3. Options label on rear panel.

Voltage-range selection

Set the Timer/Counter to the local line voltage before connecting it. As delivered the Timer/Counter may be set to either 115 V or 230 V. The setting is indicated on the voltage range selector on the rear panel.

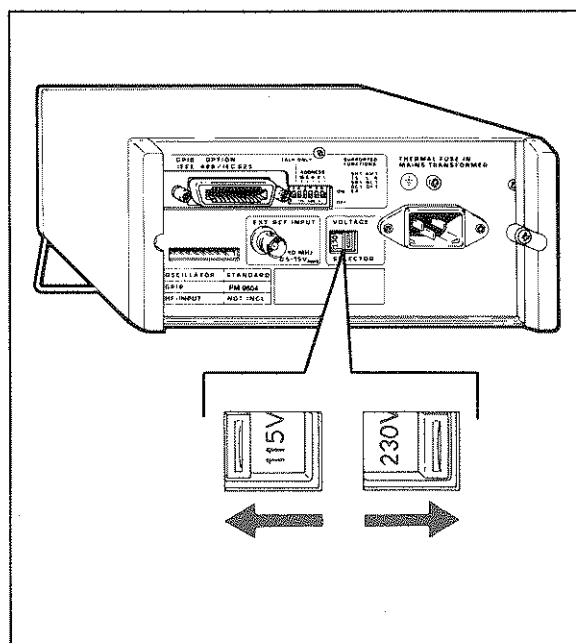

Figure 4. Location of voltage range selector.

If the voltage range setting is incorrect, set the selector in accordance with the local voltage before connecting the power cable to the line.

Grounding

The Timer/Counter is connected to ground via a sealed three-core power cable, which must be plugged into a socket outlet with a protective ground terminal. No other grounding is permitted for this Timer/Counter. Extension cables must always have a protective ground conductor.

WARNING: Never interrupt the protective grounding intentionally. Any interruption of the protective ground connection inside or outside the instrument, or disconnection of the protective ground terminal is likely to make the instrument dangerous.

Connecting external reference

If you wish to use an external 10 MHz reference frequency source, connect it via a BNC-cable to the EXT REF INPUT on the rear panel of the Timer/Counter.

When the Timer/Counter starts measuring, it automatically detects the external reference and begins to use it. The EXT REF indicator on the display is switched on.

Installing options

Introduction

The options ordered at the same time as the Timer/Counter are normally factory-installed. Other options can be fitted when needed.

The options fit inside the Timer/Counter, but not all at the same time: The HF-input, the high stability-oscillator and *either of the GPIB-interface or the Battery-unit* can be installed in one and the same Timer/Counter.

Removing the cover

WARNING: *When you remove the cover you will expose live parts and accessible terminals which can be dangerous to life.*

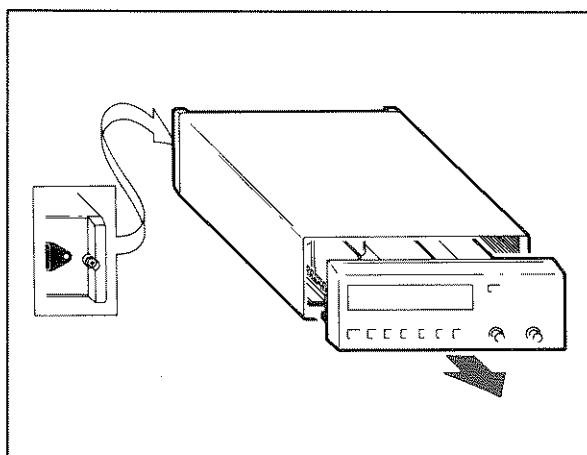

Figure 5. Loosen these screws to remove cover.

- 1) Make sure that the power cable is disconnected.

WARNING: *Although the power switch is in the off position, the line voltage is present on the printed circuit board.*

- 2) Loosen the two screws in the rear feet.
- 3) Grip around the front panel and gently pull the Timer/Counter out of the cover.

HF-input

- 1) Remove the cover of the Timer/Counter.
- 2) Push the plastic plug out of the Input-C hole in the front panel.
- 3) Push the BNC-connector cable through the front-panel.

- 4) Fit the washer and nut on the inner side of the front panel.
- 5) Use a 13 mm socket and a pair of adjustable pliers to fasten the nut.

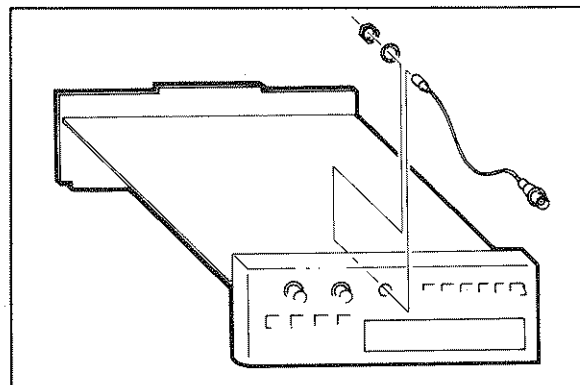

Figure 6. Fitting Input-C BNC-connector.

The HF-input should be fitted to the left of the screening plate in the middle of the Timer/Counter.

- 6) Fit the HF-input. Make sure that the connector pins fit exactly in the holes in the connector housing.
- 7) Press the board down until the clips engage with the tongues of the HF-input printed-circuit-board.

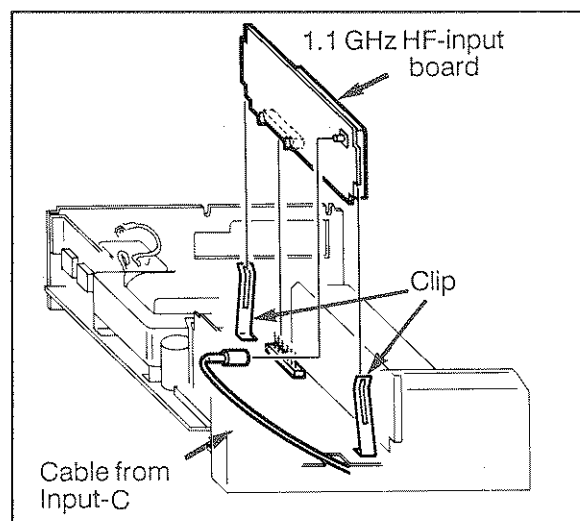

Figure 7. Fitting the HF-input.

- 8) Connect the cable from the Input-C BNC-connector to the mini-coax connector on the HF-input.
- 9) Fit the cover.

MTCXO Time-base oscillator

- 1) Remove the cover of the Timer/Counter.

The time-base fits in the front left corner of the Timer/Counter, behind the display.

- 2) Bend the clips apart and lift out the uncompensated oscillator.
- 3) Fit the new oscillator. Ensure that the connector pins fit exactly in the holes in the connector housing.

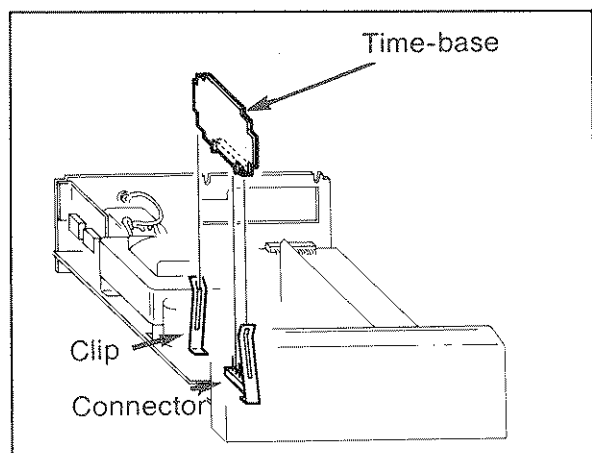

Figure 8. Replacing the Time-base.

- 4) Fit the cover.

GPIB-interface

- 1) Remove the cover.

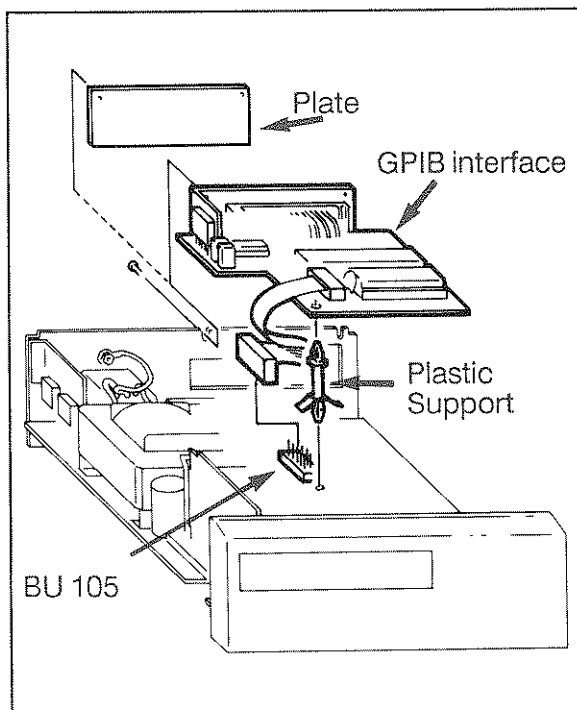

Figure 9. Fitting a GPIB-interface.

- 2) Loosen the two screws holding the plate over the opening in the rear panel.
- 3) Fit the plastic support in the hole next to BU105 on the main PC-board.
- 4) Connect the cable from the GPIB-interface to BU105.
- 5) Clip the interface to the plastic support and fix it with two screws in the rear panel.
- 6) Fit the cover.

Battery unit

- 1) Remove the cover.
- 2) Loosen the two screws holding the plate over the opening in the rear panel.
- 3) Connect the cable from the battery unit to BU105 on the main PC-board.
- 4) Fasten the battery unit with two screws in the rear panel and one under the main PC-board.
- 5) Fit the cover.

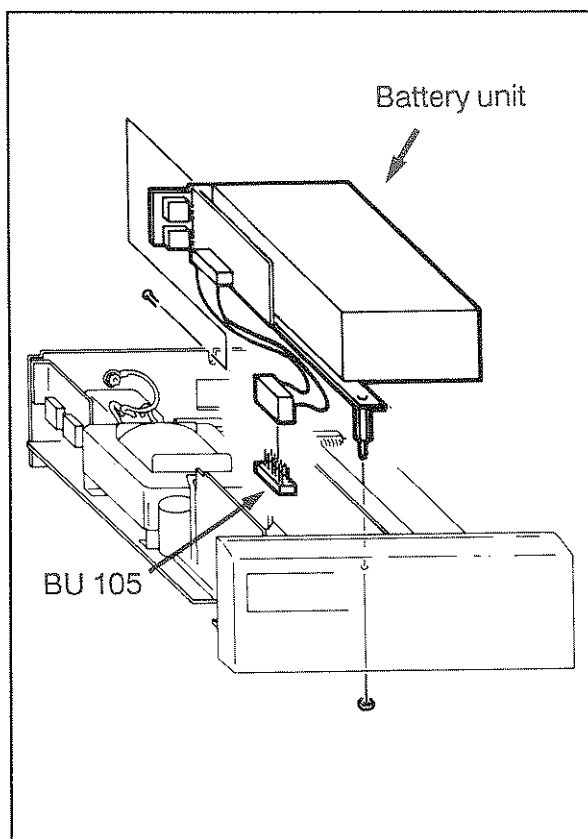

Figure 10. Fitting a Battery unit.

Rack-mount kit

- 1) Turn the Timer/counter upside down and remove the tilting support.

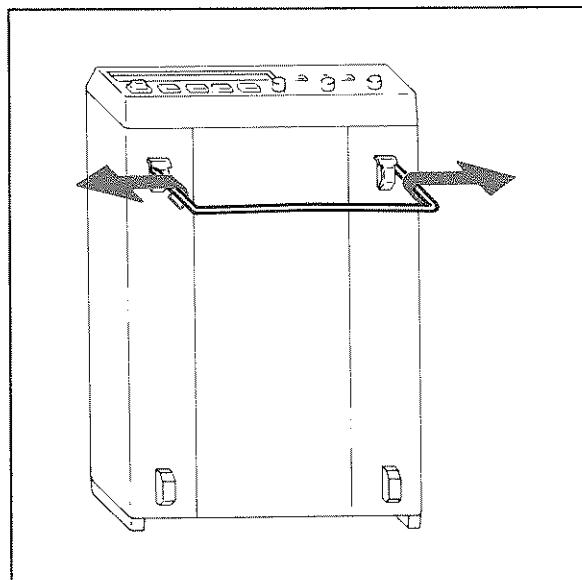

Figure 11. Removing the tilting support.

- 2) Place the rack-mount adapter over the counter so that the front feet of the counter protrude through the holes of the adapter, as seen in the drawing below.

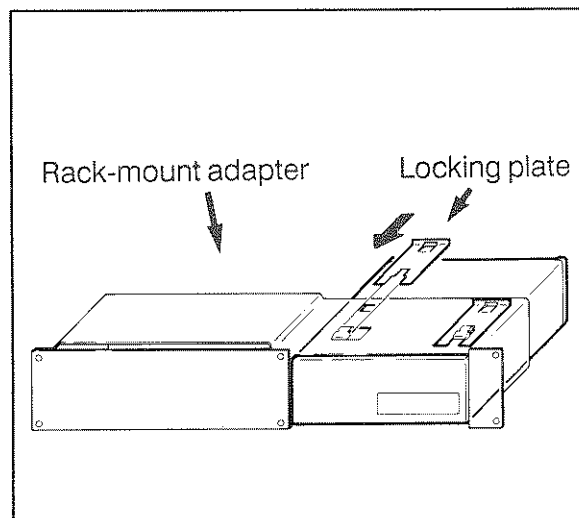

Figure 12. Fasten the counter in a Rack-mount kit.

- 3) Fasten the counter with the two locking plates.

There is room for another instrument in the rack-mount kit. The fixing-holes are made for a PM 2534 system volt-meter, but any instrument of suitable size can be fitted if you drill new holes.

OPERATING INSTRUCTIONS

General

The layout of the front and rear panel has already been presented on page 6 and 7.

Switching on

The power switch is located at the lower left corner of the front panel. The Timer/Counter may be switched on after making sure that the installation instructions on page 9 to 14 have been followed.

Timer/Counter settings after switching on

After the power-on test, the Timer/Counter returns to a default setting with the following selections:

<i>Function:</i>	FREQ A
<i>Measuring-Time:</i>	0.2 s
<i>Coupling:</i>	AC on Input-A and DC on Input-B
<i>Trigger level:</i>	Auto
<i>Slope:</i>	Positive on inputs A and B

Front panel logic

The front panel is designed to be logical and easy to use with only a few powerful multi-function buttons and a large and clear LCD display.

The text of the front panel is printed in four different colours:

BLUE	Measuring-time; control and indicator.
GREEN	Input A and B settings; Active function when the green indicator in the button is switched on.
ORANGE	Input-C option, function selection and input connector.
RED	Set value buttons and indicators.
WHITE	Input-A and B, function selection and other general functions. The function selection button is also white in order to make it easy to find.

Using the Timer/counter

CONTROL

OPERATING THE CONTROL

DISPLAY

GPIB-CODE

POWER



POWER, a two-position mechanical push-button
 Depressed = ON
 Released = OFF

POWER ON TEST

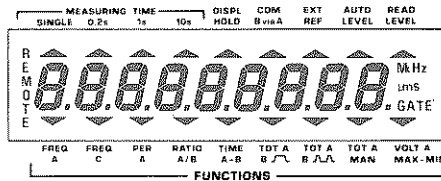

No control possible but **D** gives the same settings as after power-ON.

DEFAULT SETTINGS

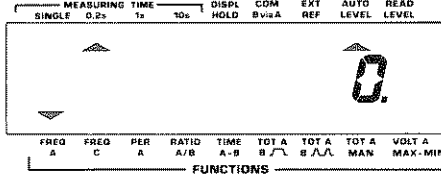

FUNCTIONS



A short depression of the **FUNCTION** button moves the cursor in the lower edge of the display one step to the right. If the button is held depressed, the cursor will scroll to the right until released. When the cursor reaches the rightmost position it jumps back to the leftmost position and continues from there.

One code for each function
 - see below:

FUNCTIONS



Move function cursor to **FREQ A**

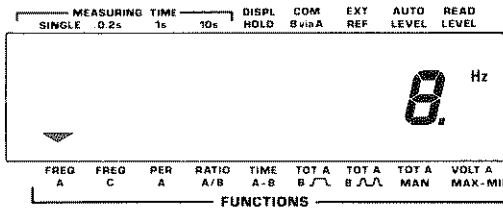

FREQ A
 (FREQ B possible via Bus)

FUNCTIONS



Move function cursor to **FREQ C**

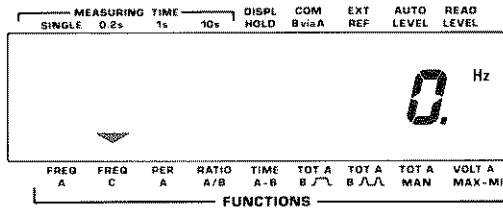

FREQ C

FUNCTIONS



Move function cursor to **PER A**

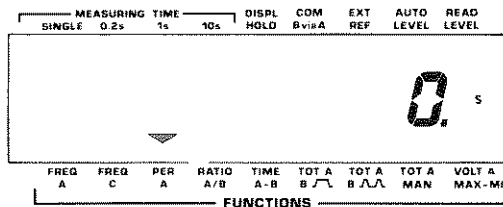

PER A

FUNCTION AND RANGE

HINTS AND COMMENTS

Switches the power ON and OFF. When switched on, the built in microprocessor switches on all segments of the display then it runs a power-up test, checking the measuring-logic of the Timer/Counter before the counter starts working. This test takes about 2 seconds.

If an error is found, an error code will be displayed. Try switching the Timer/Counter off and on again. If error code 01 - 03 persists, call Philips service. Look on the last page in this manual for Phone No. and address.

WARNING: The power switch operates on the secondary side of the transformer. The power cable must be disconnected from the line outlet socket if it is necessary to completely isolate the Timer/Counter from the line.

Error 01 = RAM memory error
Error 02 = Measuring logic error
Error 03 = Internal bus error
Error OF = Overflow in the counting registers

Selects one of the nine measuring functions available.

The cursor does not stop at **FREQ C** if no Input-C HF-input is installed.

Reciprocal frequency measurement of the signal at Input-A.

Range: 0.1 Hz to 12 MHz (SINGLE measuring-time)
1 Hz to 120 MHz (0.2, 1, and 10 s measuring-time)

If the signal is sine shaped and the input AC coupled, the minimum input frequency is 20 Hz (at specified sensitivity).

Reciprocal frequency measurement of the signal at Input-C.

Range: 70 to 1300 MHz (PM 9608B)
70 to 1000 MHz (PM 9615)
100 MHz to 1100 MHz (PM 9608)

The cursor does not stop at **FREQ C** if no Input-C HF-input is installed.

When you select **SINGLE**, the Timer/Counter measures one period, the range is: 100 ns to 200 000 000 s (about 6 years and four months!).

Use **SINGLE** when the input frequency is low. This shortens the measuring time considerably since one cycle is measured instead of 10.

When you select 0.2, 1, and 10 s Measuring-time, the Timer/Counter divides the input frequency by 10 and measures the average period for the No. of cycles in that time. **Range:** 8 ns to 1 s.

CONTROL

OPERATING THE CONTROL

DISPLAY

GPIB-CODE

FUNCTIONS



Move function cursor to **RATIO A/B**

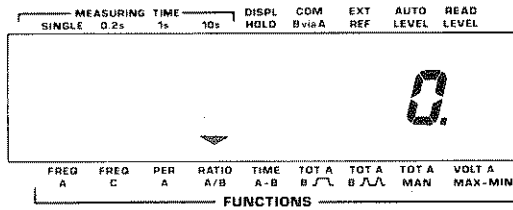

RATIO A,B
(RATIO B,A
RATIO C/A and
RATIO C/B
also possible
via bus)

FUNCTIONS

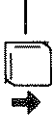

Move function cursor to **TIME A-B**

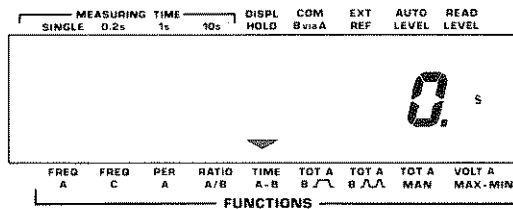

TIME A,B
(TIME B,A also
possible via
bus)

FUNCTIONS



Move function cursor to **TOT A B**

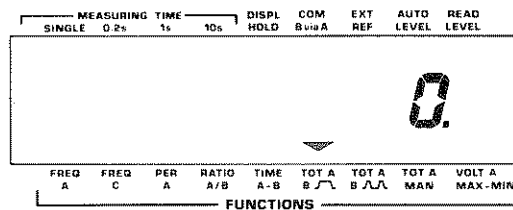

TOTG A,B
(TOTG B,A
also possible via
bus)

FUNCTIONS



Move function cursor to **TOT A B**

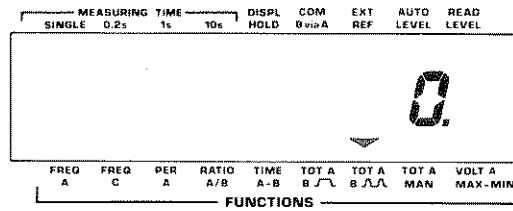

TOTS A,B
(TOTS B,A
also possible via
bus)

FUNCTIONS



Move function cursor to **TOT A MAN**

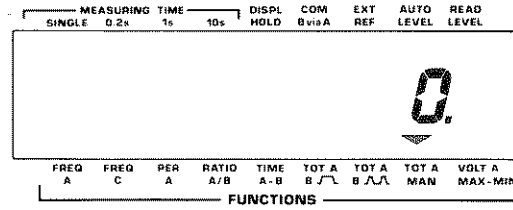

TOTM A
(TOTM B also
possible via
Bus)

FUNCTIONS



Move function cursor to **VOLT A MAX-MIN**

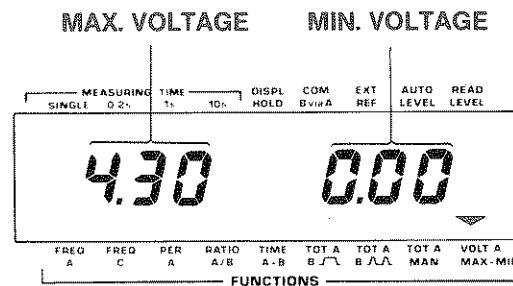

**VMAX A,
VMIN A**
(VMAX B and
VMIN B poss-
ible via Bus)

FUNCTION AND RANGE

HINTS AND COMMENTS

The number of pulses at Input-A and the number of pulses at Input-B are fed into one register each. When the set Measuring-time has elapsed, register A is divided by register B.

Range: $1 \cdot 10^{-7} \dots 1.2 \cdot 10^9$

The signal with the lowest frequency must always be connected to Input-B.

The Timer/Counter measures the time between a positive slope on Input-A and a positive slope on Input-B (default).

Range: 100 ns... $2 \cdot 10^8$ s (SINGLE)
0 ns...20 s (average, the signal must be asynchronous with the time base)

Use the SLOPE buttons if you wish to measure between any other combination of slopes.

The Timer/Counter counts the total number of pulses fed to Input-A. The positive slope of the Input-B signal starts the totalizing, and the negative slope stops it. This is always a SINGLE measurement.

Range: 0 to $1 \cdot 10^{15}$ pulses.

k on the display indicates kilo-pulses ($\cdot 1000$) and M indicates Mega-pulses ($\cdot 1\,000\,000$).

Use the Input-B SLOPE button if you wish to measure during a negative pulse on Input-B

The Timer/Counter counts the total number of pulses fed to Input-A. The positive slope of the first pulse on Input-B starts the totalizing, and the positive slope of the next pulse stops it. This is always a SINGLE measurement.

Range: 0 to $1 \cdot 10^{15}$ pulses.

k on the display indicates kilo-pulses ($\cdot 1000$) and M indicates Mega-pulses ($\cdot 1\,000\,000$).

Use the Input-B SLOPE button if you wish to measure between two consecutive negative pulses on Input-B.

The Timer/Counter counts the total number of pulses fed to Input-A. You start and stop the totalizing with the TOTALIZE START/STOP button (RESET/LOCAL). If you keep this button depressed for more than one second, the total sum will be reset.

Range: 0 to $1 \cdot 10^{15}$ pulses.

k on the display indicates kilo-pulses ($\cdot 1000$) and M indicates Mega-pulses ($\cdot 1\,000\,000$).

The Measuring-time indicator is switched off in TOT A MAN.

The timer counter will measure the positive and negative peak voltage and display them as voltage relative to 0 V.

Range: -51 V...+51 V.

The attenuator will switch in and out automatically when needed during voltage measurements regardless if AUTO LEVEL is selected or not.



MEAS TIME is operated in the same way as the functions control, see page 18.

MTIME <num> where <num> is the time in seconds. Range 10 ms to 10 s. 0 = Single



Move the measuring-time cursor to SINGLE

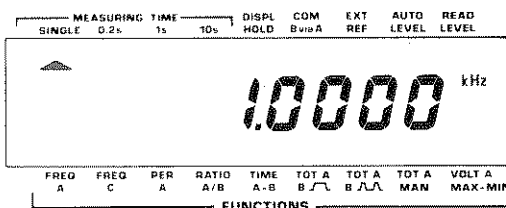

MTIME 0



Move the measuring-time cursor to 0.2 s

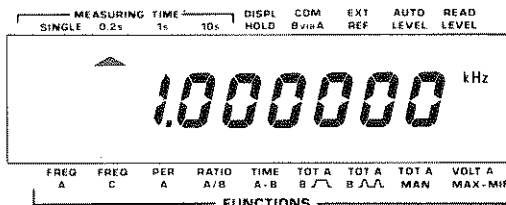

MTIME 0.2



Move the measuring-time cursor to 1 s

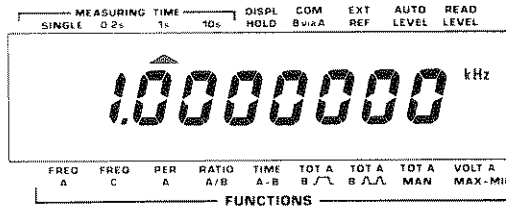

MTIME 1



Move the measuring-time cursor to 10 s

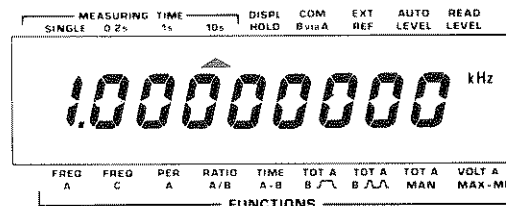

MTIME 10

FUNCTION AND RANGE

HINTS AND COMMENTS

The set Measuring-time controls the time during which the main gate is opened, allowing pulses to enter the counting logic. A longer Measuring-time gives higher resolution readouts with more digits displayed.

The time the gate is open is not exactly the preset Measuring-time, because the Timer/Counter synchronizes the measurement with the input signal in order to measure complete periods. If the period of the input signal is longer than the set Measuring-time, the main gate does not close again until the period is completed.

If you wish to do one measurement instead of repetitive measurements, see DISPL HOLD.

When TOT A $\sqrt{\quad}$ B or TOT A $\sqrt{\quad}$ B is selected, the Measuring-time setting will be used to set the display time.

For PER A and TIME A-B exactly one period or one time interval is measured. The minimum result possible is 100 ns.

The display time will be 100 ms.

When set to SINGLE and FREQ A, the Measuring-time is one cycle of the input signal or 3 ms, whichever is longest. When set to SINGLE and FREQ C, the Measuring-time is 3 ms.

The input frequency is limited to 12 MHz for FREQ A and PER A.

If external reference is used, the EXT REF indicator will not be switched-on until after the first measurement.

A Frequency-A measurement will result in 6-7 digits on the display.

A Frequency-A measurement will result in 7-8 digits on the display.

A Frequency-A measurement will result in 8-9 digits on the display.

CONTROL

OPERATING THE CONTROL

DISPLAY

GPIB-CODE

RESET/ LOCAL



TOTALIZE START/STOP

RESET/LOCAL, a short press is enough for Reset. When the remote indicator is on, a press will cause the counter to switch back to LOCAL, i.e. control from the front panel.

TOTALIZE START/STOP, one press starts totalizing, the next press stops.

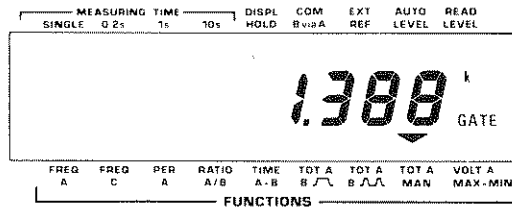

X starts a new measurement.

GATE OPEN starts and **GATE CLOSE** stops Totalize MAN.

DISPL HOLD



Switches 'on' or 'off' **DISPL HOLD** when depressed.

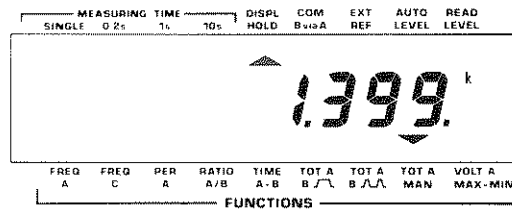

Not bus controllable, but Free-run OFF will give a similar function; See GPIB-bus operation.

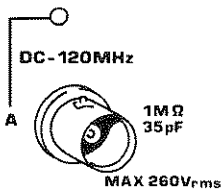

Connect the signal to **INPUT-A** via a BNC-cable.

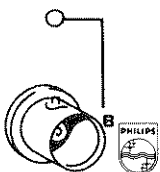

Connect the signal to **INPUT-B** via a BNC-cable.

FUNCTION AND RANGE

When reset is depressed, the display and counting registers are cleared. When reset is released, a new measurement is started. The Measuring-time-, Function- and display hold- settings are not affected.

If the TOT A MAN function is selected, the RESET/LOCAL button functions as a START/STOP button. One press starts the counting and the next press stops it. A long depression results in reset.

Display hold freezes the display, but not until the measurement in process has been finished. A new measurement can always be initiated via the RESET button.

HINTS AND COMMENTS

When the counter is controlled from the GPIB-Bus, the LOCAL button can be disabled via the 'Local Lock out' command.

Use this input for all functions except **FREQ C**.

Input data:

Range: DC Hz to 120 MHz

Impedance: 1 M Ω /35 pF.

Min. pulse duration: 4 ns

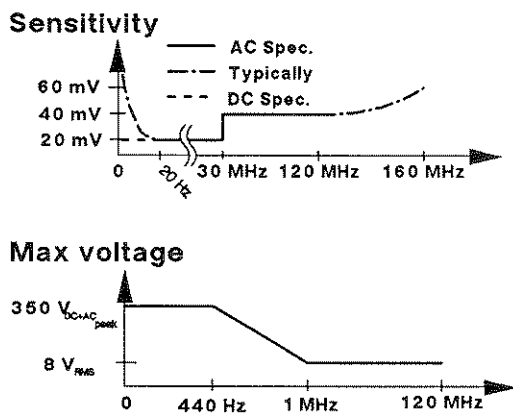

This input is used for Ratio A/B, Time A-B and TOT A start/stop (or gated) by B measurements.

Range: Identical to Input-A

At higher frequencies; use a 50 Ω termination type PM 9585 to avoid interference caused by impedance mismatch.

The illustration below shows which function block each of the input controls affect.

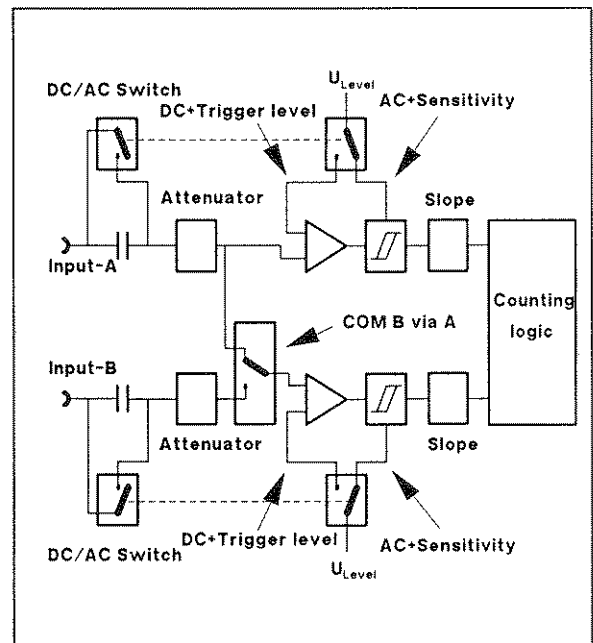

Figure 13. Input circuit block diagram.

CONTROL

OPERATING THE CONTROL

DISPLAY

GPIB-CODE



One **ATTx1/x10** push button for each of input A and B. Switch the indicator ON to select 10 times attenuation and OFF to switch off the attenuator.

ATT ON
ATT OFF
You must first select input with INPA or INPB.



One **SLOPE** push-button for each of input A and B. Switch the indicator ON to select negative slope, and OFF to select positive slope.

TRGSLP POS
TRGSLP NEG
You must first select input with INPA or INPB.



One **DC/AC** push-button for each of input A and B. Switch the indicator ON to select AC and OFF to select DC.

NOTE: Sensitivity can be set when AC-coupled and Trigger Level when DC-coupled.

COUPL AC
COUPL DC
You must first select input with INPA or INPB.



A depression switches the **AUTO LEVEL** indicator on or off.

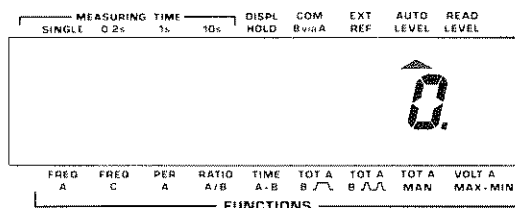

AUTO ON
AUTO OFF



Depress the **SET VALUE** button once and the indicator in the button switches on. Now the auto level and Read level buttons have the red arrow up and down function. Another press will switch off the function.

NOTE: Sensitivity can be set when AC-coupled and Trigger Level when DC-coupled.

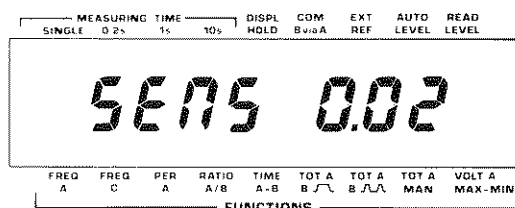

Separate Codes for trigger level and sensitivity
SENS1 = 20 mV
SENS2 = 50 mV
SENS3 = 100mV

TRGLVL <num>
 <num> = -5.1 to +5.1 V.
 You must first select input with INPA or INPB.

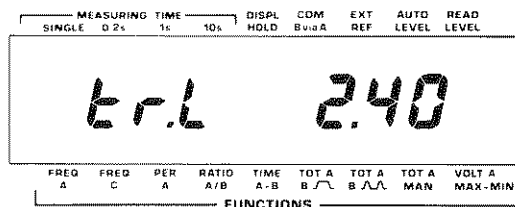

FUNCTION AND RANGE

HINTS AND COMMENTS

When the indicator in the button is OFF, the signal is un-attenuated; the trigger level range is -5 V to +5 V and the sensitivity can be 0.02, 0.05 or 0.1 V.

When the indicator is ON the signal is attenuated 10 times; the Trigger level range becomes -50 V to +50 V and the sensitivity becomes be 0.2 V, 0.5 or 1.0 V.

If Auto Level or Volt is selected, the correct attenuator setting will be selected automatically.

When the button indicator is ON, the active slope of the input is changed from positive to negative.

Dual functions:

- 1) AC- or DC- coupled input.
- 2) Selection of variable sensitivity (AC) with 0 V trigger level or selection of variable trigger level (DC) with maximum sensitivity.

NOTE: AC coupling together with Auto Level results in maximum sensitivity and automatic trigger level setting.

- You can remove any DC-component with AC-coupling.

For frequency- period- ratio- measurements: Select AC-coupling and set the sensitivity so that the hysteresis band of the Timer/Counter is about half the amplitude of the input signal.

For time measurements: Select DC-coupling and set the trigger level to the desired level.

The auto-level function always sets the DC trigger-level to 50% of the amplitude, it does also switch on the attenuators when needed. Auto-level is selected simultaneously for both A and B inputs.

NOTE: Auto level gives automatic trigger level setting to AC coupled inputs also.

The measuring rate is reduced to about two measurements/second when using Auto-Level.

Use Read-Level to check what trigger-levels Auto-Level has selected.

For frequency- period- ratio- measurements:

Select AC-coupling and set the sensitivity so that the hysteresis band of the Timer/Counter is about half the amplitude of the input signal.

If the sensitivity is too high, the Timer/Counter will be triggered by noise and interference instead of by the signal.

For time measurements:

Select DC-coupling and set the trigger level to the desired level.

CONTROL

OPERATING THE CONTROL

DISPLAY

GPIB-CODE



The **READ LEVEL** push-button. When the indicator is on, the display shows the trigger levels on the display.

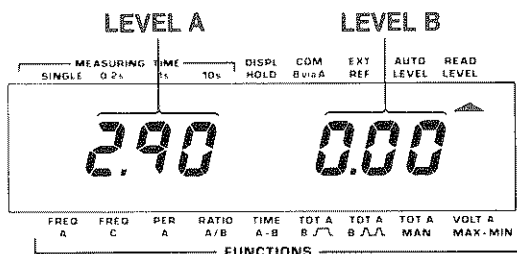

Use INPA? and INPB? to read input settings to the controller



The **COM B via A** push-button. When the indicator is on the signal on Input-A is also connected to Input-B.

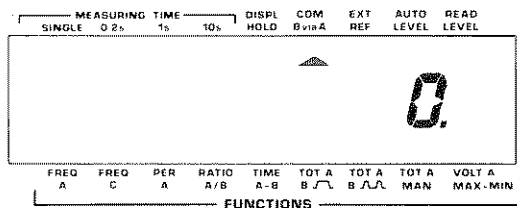

COM ON
COM OFF

0.1-1.1GHz



Connect the signal to **INPUT-C** via a BNC-cable.

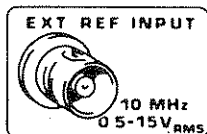

Connect an external 10 MHz frequency source to the BNC-connector on the rear panel of the Timer/Counter marked **EXT REF INPUT**.

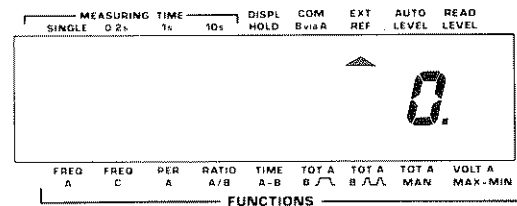

Not bus controllable.

FUNCTION AND RANGE

HINTS AND COMMENTS

When active, trigger levels will be displayed according to this table:

	Auto Level	Manual
DC	Level selected by Auto.	Level set using Set Value.
AC	Level selected by auto.	0 V.

Use Read-Level to check what trigger-levels Auto-Level has selected.

When active, the signal on Input-A is also connected to Input-B.

The DC/AC and Attenuator switches for Input-A affects both Input-A and B. The Input-B DC/AC and Attenuator switches have no effect. (See figure 13).

Trigger level/sensitivity and Slope can be selected separately.

You can use COM B via A and the manual trigger level settings to make accurate rise-time measurements:

1. Select AC-coupling, COM B via A and positive slope for input A and B.
2. Select VOLT A MAX-MIN and read the amplitude of the signal.
3. Calculate 10 % of the peak to peak voltage.
4. Depress SET A, use ↑ and ↓ to set trigger level A to the MIN reading plus the 10 % of V_{pp}.
5. Depress SET B, use ↑ and ↓ to set trigger level B to the MAX reading minus the 10 % of V_{pp}.
6. Select TIME A-B.

This is the 1.1 GHz HF-input which must be used when the FREQ-C function is selected. If the Timer/Counter does not include the Input-C option, the BNC-connector is replaced by a plastic plug.

Range: 100 to 1100 MHz.
Impedance: 50 Ω
Sensitivity: 10 mV_{RMS} up to 900 MHz and 15 mV_{RMS} above.
Max voltage: 12 V_{RMS}

RATIO C/A and RATIO C/B can be selected via the bus.

The Timer/Counter automatically detects if a suitable signal is connected to the EXT- REF Input-connector.

Suitable signal:
 10 ± 0.1 MHz, 0.5 to 15 V_{RMS} Sine wave.

Use external reference when the measurement requires ultra-high stability.

The Timer/Counter must still have the internal time base even if an external reference frequency is used.

If single is selected, the EXT REF indicator on the display is not switched on until after the first measurement.

Battery unit

Operation

When a battery unit is installed, the counter can operate for 2 hours without mains supply. The display starts blinking shortly before the battery is discharged.

The counter charges the battery automatically when connected to the mains, no matter how the Power-switch is set. Charging a discharged battery to 75 % of full capacity will take 7 hours, and to full capacity, 24 hours.

If the counter is connected to the mains and switched on, it will not switch to battery operation if you disconnect the mains. You must first switch the counter OFF with the power switch, then ON again before the battery unit supplies the counter.

Battery care

The capacity of the rechargeable battery degrades if the counter is not powered by the battery frequently. To keep the battery from degrading, cycle the battery, from fully charged to fully discharged, occasionally.

The capacity of a degraded battery can be restored by cycling the battery a number of times, but a restored battery will never reach the capacity of a new one.

If you must store your counter for some time without using it, store it in a cool and dry place. Leave the counter with the mains cable connected if possible. If not, don't disconnect the mains cable until the battery is fully charged, then charge the battery for at least 8 hours every 3 months.

CAUTION: *Prolonged storage or use of the counter at temperatures above +40° C shortens the life of the battery.*

The battery will freeze if it is not sufficiently charged when stored at a low temperature. 75% charge is sufficient for -40° C.

Calibrating the MTCXO

The MTCXO Time-base can easily be recalibrated to any 10 MHz reference. To maintain the accuracy of the MTCXO, use a reference with an accuracy of $3 \cdot 10^{-8}$.

The PM 9691 oven-enclosed oscillator used in Philips counters version /.5. meet this requirement, *if calibrated.*

Preparations

If you remove the cover when counter has been switched on, the temperature of the MTCXO will rapidly drop about 10°C. Since the MTCXO must have a stable temperature when calibrated you must wait an hour between removing the cover and calibrating.

If the counter has been switched off more than three hours, you can calibrate it directly.

Calibration procedure

- 1) Remove the cover from the counter.
- 2) Allow the MTCXO to adapt the new ambient temperature. (See 'Preparations'.)
- 3) Connect the 10 MHz reference to Input-A.
- 4) Switch ON the counter.
- 5) Adjust the sensitivity control so that the counter counts properly.

- 6) Hold down the CALIB-button, on the main printed-circuit board in the counter, and press the Reset-button.

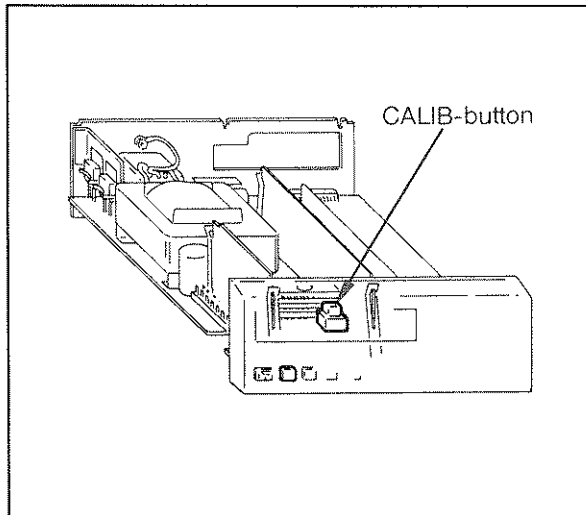

Figure 14. Location of the CALIB-button.

- 7) Wait about 20 seconds, until the display shows 10.000000 MHz. Now the oscillator is calibrated.
- 8) Switch OFF the counter and disconnect the 10 MHz reference.
- 9) Fit the cover.

Error codes

The counter can display the following error codes if something goes wrong.

<i>Error OF</i>	Overflow in the counting registers. Select a shorter Measuring-time if you get this error code, unless the counter is set to TOTALIZE, then you must press reset and start again from zero.
<i>Error 01</i>	RAM memory error
<i>Error 02</i>	Measuring logic error
<i>Error 03</i>	Internal bus error

If the counter shows one of these error codes, try switching the counter off and on again. If error code 01-03 persists, call Philips service. Look on the last page in this manual for Phone No. and address.

GPIB-INTERFACE OPERATION

Introduction

The PM 6666 can be controlled by a computer (controller) via the GPIB-interface option, PM 9604. All functions that can be controlled from the front panel can also be controlled via the bus in a similar way, except the power switch. The additional micro-processor on the interface board has made it possible to add functions. You can obtain continuously variable Measuring-time, bus-learn, high-speed-dump etc., but these functions are only accessible via the bus.

To select a function, you send a command to the counter. We have chosen the text on the front panel as commands, wherever possible, in order to make them easy to remember. E.g. the command to select Frequency-C is FREQ C and the command to select Ratio A/B is RATIO A,B.

NOTE: *The characters in a command can be in both upper and lower case.*

What can I do using the bus?

All the capabilities of the interface for the PM 6666 are explained below. If you want a complete description of all GPIB-interface functions, read the 'Philips Instrumentation-Systems Reference-Manual'.

Summary

Description	Code
Source handshake	SH1
Acceptor handshake	AH1
Control function	C \emptyset
Talker Function	T5
Listener function	L4
Service request	SR1
Remote/local function	RL1
Parallel poll	PP \emptyset
Device clear function	DC1
Device trigger function	DT1
Bus drivers	E2

Source and Acceptor Handshake SH1, AH1

SH1 and AH1 simply means that the counter can exchange data with other instruments or a controller, using the bus handshake lines; DAV, NRFD, NADC.

Control function, C \emptyset

The counter does not function as a controller.

Talker function, T5

The counter can send responses and the results of its measurements to other devices or to the controller. T5 means that it has the following functions:

- Basic talker.
- Talk only mode.
- It can send out a status byte as response to a serial poll from the controller .
- Automatic un-addressing as talker when it is addressed as a listener.

Listener function, L4

The counter can receive programming instructions from the controller. L4 means the following functions:

- Basic listener.
- No listen only.
- Automatic un-addressing as listener when addressed as a talker.

Service request, SR1

The counter can call for attention from the controller e.g. when a measurement is completed and a result is available.

Remote/local, RL1

You can control the counter manually (locally) from the front panel, or remotely from the controller. The LLO, local-lock-out function, can disable the LOCAL button on the front panel.

Parallel poll, PP \emptyset

The counter does not have any parallel poll facility.

Device clear, DC1

The controller can reset the counter, forcing it to default settings, via interface message DCL (Device clear) or SDC (Selective Device Clear).

Device Trigger, DT1

You can start a new measurement from the controller via interface message GET (Group Execute Trigger).

Bus drivers, E2

The GPIB interface has tri-state bus drivers.

Connecting the controller

The bus interface connector is on the rear panel of the counter. If your counter does not have any connector, you must install the GPIB-interface option, see installation.

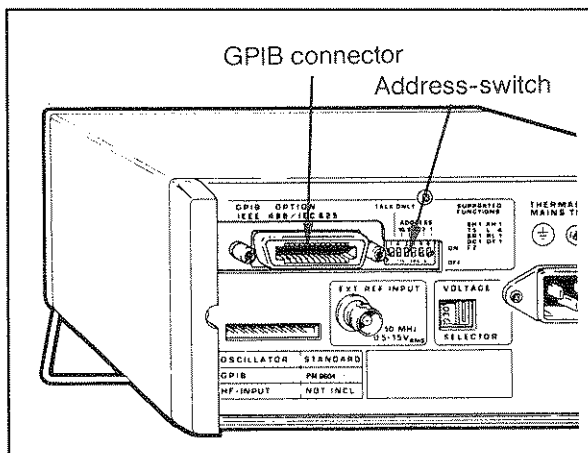

Figure 15. GPIB connector and address switch, the numbers above the switches indicate the significance of each switch.

Connect the controller via an IEEE-488 cable to the bus connector. If you use IEC-625 cables, an adapter is available, see ordering information at the end of this manual.

Giving the counter an address

The counter must have a unique address so that the controller can communicate with it. The address is selected by setting switches to the binary equivalent of the address you want. The switches are located to the right of the interface connector. The OFF position means 0 and the ON position means 1.

Ad- dress	Switch settings	Ad- dress	Switch settings	Ad- dress	Switch settings
0	00000	10*	01010	20	10100
1	00001	11	01011	21	10101
2	00010	12	01100	22	10110
3	00011	13	01101	23	10111
4	00100	14	01110	24	11000
5	00101	15	01111	25	11001
6	00110	16	10000	26	11010
7	00111	17	10001	27	11011
8	01000	18	10010	28	11100
9	01001	19	10011	29	11101
				30	11110

* Factory setting.

NOTE: 31 is the bus command for "Untalk" and should not be used. If 31 is selected the counter will work as if address 0 is selected.

Talk-Only

The leftmost switch in the address switch block is the TALK ONLY switch. If you set it to '1', the counter will output measurement results on the bus continuously. It will not react to any incoming commands.

This setting may only be used if the counter is connected to a 'Listen only' device such as a printer. Set the switch to '0' when you want normal bus communication.

Talk only is set to '0' on delivery.

The counter is now ready for bus control.

Checking the communication

To check if the counter and the controller can communicate, address the counter and execute the following sequence: (The programming example is for an HP-85 controller.)

Type on controller:	This should happen.
REMOTE 710	The remote indicator should be switched on.
OUTPUT 710;"ID?"	Ask for the counter identity.
ENTER 710;A\$	Input result from counter.
DISP A\$	The response on the display of the controller is the identity of the counter.

If everything is OK, the counter will identify itself as:

PM6666/YZW/MN

where: Y = 4 if the counter has an HF-input, otherwise 0.
 Z = 3 for MTCXO, otherwise 1
 W = 6 (GPIB-bus is installed)
 M = Revision No. of counter firmware
 N = Revision No. of GPIB-bus firmware

Two ways of programming

The simplest way of programming the counter is by manually setting up the measurement you want from the front panel of the counter, then let the controller ask the counter how it is set up. The data the controller gets from the counter can be used to set up the same measurement over and over again. This method is called 'Bus-learn' and will be explained later.

The other method is to make a program message where each step of the set-up is separately specified.

Programming check-list

Check that the following steps have been taken to ensure correct programming of the instrument.

Normally only the six first steps must be programmed.

1. Do you know the current setting of the counter?
If not, send device clear 'D' to get the default settings.
2. Select Measuring-function; (Default: Frequency-A.)
3. Select Measuring-time; (Default: 0.2 s.)
4. Select Trigger-slopes;
(Default on Input-A and Input-B: Positive.)
5. Select Coupling;
(Default on Input-A: AC.)
(Default on Input-B: DC.)
6. Select Trigger-level; (Default: AUTO.)

For advanced programming, check the following steps.

7. Set Output separator; (Default: LF.)
8. Set EOI mode; (Default: OFF.)
9. Set service request(SRQ) -mask;
(Default, No SRQ.)
10. Select Free-Run on or off;
(Default: ON.)
11. If Free-Run is off, select Time-Out if desired;
(Default: Infinite, programmed as 0 s.)
12. Set Output-mode;
(Default: Normal output format, High-speed dump OFF and MTCXO compensation ON.)

All functions and commands in the checklist will be explained later.

NOTE: *You only have to program the changes from the previous set-up.*

Syntax

What is a programming command?

A programming command consists of a header, addressing the function you want, and a body instructing the function what to do.

EXAMPLE: TRGSLP POS
 ↑ ↑
 HEADER, addressing BODY, switching
 Trigger Slope slope to positive

NOTE: *Some programming commands consists only of the Header, e.g. trigger command 'X'.*

What is a programming message?

A programming message is a number of programming commands with separators between them. E.g. the commands necessary to set up a measurement.

EXAMPLE: PER A ; MTIME 0

Input separator

All communication between the counter and the controller uses sequences of ASCII-characters terminated by a separator. Input separators are the separators sent by the controller. They are used in four different places:

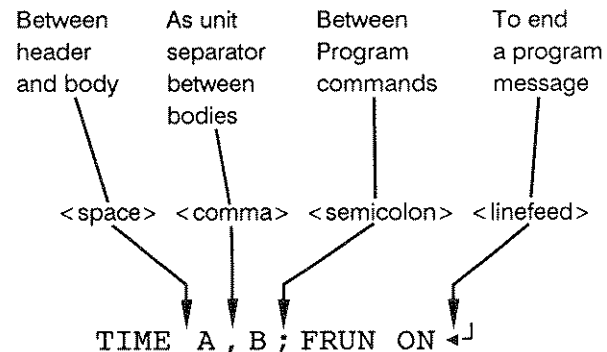

The separators in the example above are the ones normally used in respective place. The counter will however accept any one in any place.

The following separators will also work in any of the four places: colon, CR, ETB, ETX, the separator selected as output separator, as well as an active EOI-signal.

Order of commands in a program message

Normally, the programming commands in a programming message can be placed in any order.

However, the following commands must always be placed at the end of a program message since any command sent after them will disable the selection:

```
INPA?   MEAC?   FNC?   X
INPB?   BUS?   ID?    OUTM 4
```

These commands will be ignored if found anywhere but in the end of a message.

< Number >

In some program commands, the body is replaced by the term <number> or <num>. Here you must enter a numerical value. <number> can be entered in any format you like e.g. 1.23 can also be entered as $0.00000123 \cdot 10^7$ or $1230000 \cdot 10^{-6}$. If you enter more digits than the counter needs, your entry will be truncated. The counter will stop if an entry is out of the counters range. To proceed, the status message 'Programming error' must be reset, see 'Status byte'.

Selecting output separator

Output separators terminate messages from the counter to the controller. The separator needed is different for different controllers; see the Operators' Manual for your controller.

At power on, the output separator of the counter is linefeed 'LF' (10_{decimal}).

The output separator can be changed by sending SPR <number> to the counter. <number> is the decimal value of the ISO (ASCII)-code for the desired separator. It can be 0-26, 28-31, ESC code, 27, is not accepted.

Only one <number> can be entered as separator. If you want the combination of CR+LF (13_{dec} + 10_{dec}), it is selected by 'SPR 255'.

EXAMPLE:

```
SPR 13 changes the output separator to CR
SPR 255 changes the output separator to CR+LF
```

The counter can signal EOI together with the last output separator in responses and output data.

EOI ON switches on the function.

EOI OFF switches it off.

Default setting is EOI OFF.

The selected separator and EOI will not be altered by LOCAL from the front panel nor by LOCAL or 'Device clear' from the bus.

How to select function

Standard functions

Functions are selected by sending the appropriate function command to the counter, e.g. **FREQ A**. The space between **FREQ** and **A** indicates the input separator that you always must insert.



Function	Command	Comment
Frequency A	FREQ A	Default
Frequency C*	FREQ C	
Period A	PER A	
Ratio A/B	RATIO A,B	
Time A-B	TIME A,B	
Totalize A Gated by B	TOTG A,B	
Totalize A Start/stop by B	TOTS A,B	
Totalize A Manually	TOTM A	See 'Totalize start/stop'.
Volt A max	VMAX A	
Volt A min	VMIN A	

The function cursor on the display of the counter will jump to the selected function.

* Only possible if Input-C option, PM 9608 is installed.

Functions accessible via bus only

When you have a GPIB interface you will get the following new functions:

Function	Command	Function cursor indicates
Frequency B	FREQ B	FREQ A
Time interval B-A	TIME B,A	TIME A-B
Totalize B Manually	TOTM B	TOT A MAN
Totalize B Gated by A	TOTG B,A	TOT A  B
Totalize B Start/stop by A	TOTS B,A	TOT A  B
Ratio B/A	RATIO B,A	RATIO A/B
Ratio C/A*	RATIO C,A	RATIO A/B
Ratio C/B*	RATIO C,B	RATIO A/B
Volt B max**	VMAX B	VOLT A MAX-MIN
Volt B min**	VMIN B	VOLT A MAX-MIN

* Only possible if Input-C option, PM 9608 is installed.

** Don't use VMAX B or VMIN B together with COM B via A to measure the voltage on input A. The results will be unreliable.

When the counter switches to LOCAL, the function indicated by the Function-cursor will be selected.

The counter will not return to the 'bus only' function when it returns to remote. To return to the 'bus only' function you must re-program the counter.

The specifications of some 'bus-only' functions differ from the specifications of it's similar front-panel selectable function. See 'Specifications'.

Selecting Measuring-Time

The Measuring-time can be set to any value between 10 ms and 10 s, or SINGLE-measuring. Any value below 10 ms will be interpreted as SINGLE. Values above 10 s will be out of range and cause an error. The program command is MTIME <number>. Always enter the Measuring-time in seconds. The entered value will be truncated to the nearest 10 ms increment.

Meas. Time	Command	Comment
0.2 s	MTIME 0.2	Default
10 ms	MTIME 0.01	You will not be able to see the gate indicator blinking if the Measuring-time is below 50 ms.
7.34567 s	MTIME 7.34567	The Measuring-time will be 7.34 s.
2 ms	MTIME 0.002	Out of range, Measuring-time will be SINGLE.
SINGLE	MTIME 0	A display time of 50 ms is set so that you can see the Gate-indicator.
25 s	MTIME 25.0	Out of range and error, the counter will stop. It can indicate programming error by sending an SRQ if selected in the SRQ-mask.

The Measuring-time cursor on the display will indicate 0.2 s for all programmed Measuring-times except SINGLE, which will be indicated as usual.

Selecting Input settings

Before selecting input settings you must tell the counter which input you want to address:

Input	Command	Comment
A	INPA	Default setting.
B	INPB	

Now you can send the input setting commands:

Attenuator*	Command	Comment
• 1	ATT OFF	Default
• 10	ATT ON	
Trigger slope	Command	Comment
Positive	TRGSLP POS	Default setting.
Negative	TRGSLP NEG	

Coupling	Command	Comment
AC	COUPL AC	Default on A.
DC	COUPL DC	Default on B.

Sensitivity*	Command	Comment
	SENS <number>	
20 mV	SENS 1	Default
50 mV	SENS 2	
100 mV	SENS 3	

If ATT • 10 is selected, sensitivity will be 0.2 V, 0.5 V and 1.0 V

Trigger level*	Command	Comment
Volt	TRGLVL <num>	<num> = trigger level in Volts. Range: -5.10V to +5.10V. Minimum increment: 0.02 V. Default 0 V.

If ATT • 10 is selected, Trigger level range will be -51 V to +51 V and the minimum increment 0.2 V.

The following commands affect both inputs regardless of which input is selected:

Auto level*	Command	Comment
Automatic	AUTO ON	Default
Manual	AUTO OFF	

* If AUTO is ON, the attenuator, trigger level and sensitivity settings are controlled by AUTO. If any of these parameters are reprogrammed when AUTO is ON, the new setting will be stored and used when AUTO is switched OFF. If the controller asks for program data out during AUTO, the answer will be the selections made by AUTO.

Common B via A	Command	Comment
on	COM ON	
off	COM OFF	Default

When COM ON is selected, the AC/DC and attenuator settings of Input-A will affect both channels. If AC/DC or the attenuator of input-B is reprogrammed during COM ON, the setting will be stored and used when COM is switched OFF. The program data out for Input-B will be the programmed settings, not the Input-A settings used during COM ON.

Totalize Start/Stop

When TOT A or TOT B manual is selected, the gate is opened and closed by the controller instead of by pressing the button on the front panel. To start the counting after selecting TOTM A or TOTM B, the gate must be opened.

Totalize	Command	Comment
Start	GATE OPEN	Starts counting.
Stop	GATE CLOSE	Stops counting. Default.

NOTE: Multiple GATE OPEN/GATE CLOSE will accumulate the results in the counting registers. Any other command but GATE OPEN/GATE CLOSE will stop the totalizing and reset the counting registers to zero.

Free-Run/Triggered

The counter can work in two different ways:

- Free-Run**, where it starts a new measurement as soon as the previous measurement is finished. The first measuring result that is ready after the counter receives a read command, will be sent to the controller. When the result has been read, the output buffer is reset to zero until a new result is ready. One and the same measuring result can only be read once.
- Triggered**, where the counter waits for trigger command GET or 'X' from the controller before it starts a measurement. When the measurement is completed, the counter will wait until the controller reads the measuring results, then the output buffer is reset. The function is the same as when Displ Hold is selected from the front panel and you start a new measurement by pressing the reset button.

Free-Run	Command	Comment
Off	FRUN OFF	This function is sometimes called Triggered-Mode, so the TRIG ON command will also result in the same function.
On	FRUN ON	TRIG OFF gives the same result. Default.

Free-Run ON or OFF will not be indicated on the display. When the counter switches to LOCAL, Free-Run will always be ON but when the counter switches back to remote, it will return to its previously programmed settings.

Time-Out

When Free-Run is switched off it is possible to set a time-limit (time-out) between the start of a measurement and the time when a result is expected to be ready. If no result is achieved before the set time is out, the counter can output a Service Request, SRQ. Time-Out must be selected in the SRQ-mask; see 'Service Request'. The programming command is TOUT <number>. The timeout can be set to any value between 100 ms and 25.5 s, the minimum increment is 100 ms.

Time-Out	Command	Comment
100 ms	TOUT 0.1	Time-Out is only intended to be used with Free-Run off*.
Off	TOUT 0	Always send this command when Free-Run is switched on. Default.

Time-Out is not indicated on the display. When the counter switches to LOCAL, Time-Out is off, but when switched to remote again, the set Time-Out will be active again.

* *Time-out can be switched on when free-run is on but it will not serve any purpose.*

Bus Triggering

'X' will always cause the counter to start a new measurement. X will work as group execute trigger, GET. 'X' must always be placed in the end of a program message.

Service Request

The counter can send a service request, SRQ, when it wants service from the controller. After an SRQ, the controller must execute a serial poll which means that it must ask each of the instruments for status information until it finds the SRQ-giving instrument, evaluate the Status-byte of the instrument and then make a decision what to do.

To enable the counter to send service requests, you must set an SRQ-mask telling the instrument which conditions will cause SRQ.

Command **Comment**
MSR <number> <number> is a decimal value depending on selected SRQ reasons.

Bit	Decimal value	Reason for SRQ.
7	128	Not used.
6	64	Time-Out.
5	32	Hardware fault.
4	16	Programming error.
3	8	Measuring stop enable.
2	4	Measuring start enable.
1	2	Ready for triggering.
0	1	Measuring result ready*.

* If SRQ for Measuring result ready is selected, the counter will stop and wait until the controller fetches the result before a new measurement can start.

Write down the binary word for the required SRQ, then convert it to a decimal value and insert the value as <number>.

EXAMPLE: *If you want SRQ to be sent when the time-out elapses, when the counter is ready for triggering and when the result is ready, the binary word required is 01000011 which is decimal 67; see table below.*

Bit	Value if the bit is 1	Example	
		Binary word	Decimal value
7	128	0	0
6	64	1	64 Time-Out
5	32	0	0
4	16	0	0
3	8	0	0
2	4	0	0
1	2	1	2 Ready to trigger
0	1	1	1 Meas. result ready
		+	67

Send MSR 67 to the counter.

Status byte

The counter sends its status byte to the controller on a serial poll. The bits in the status byte reflects different events or conditions in the counter. There are two types of status bits:

A conditional bit indicates the current condition of what its monitoring, all the time.

An event bit indicate that an event has occurred. When the event occurs, the bit is set to 1. It is not reset to 0 until a new measurement starts.

The different bits indicate the following information:

Bit	Function
7	Always 0
6	1 = SRQ has been sent*, otherwise 0 (Event bit).
5	Abnormal bit. Always 0 during normal measurements, 1 if something is wrong. Affects bit 0-3, see below (Event bit).
4	0 = Main Gate closed, 1 = Main Gate open**
3-0	Depends on Abnormal bit, see below (Event bits.)

Bit	Abnormal bit = 1	Abnormal bit = 0
3	Not Used	Measuring stop enable.
2	Time-Out	Measuring start enable.
1	Hardware fault	Ready for triggering
0	Programing error	Measuring result ready.

- * Only if SRQ-mask is set for Service-Request.
- ** This is a conditional bit that monitors the Main-Gate in the counter. When TOT MAN is selected the bit will always be 0.

Measuring start enable indicates that the counter logic is ready to start a measurement.

Measuring stop enable indicates that the counter logic is ready to stop a measurement.

These bits can be used to detect if the input signal to the counter is present; If the counter never stops it's measurement and the status byte stops at:

XX00X1XX	No input signal. The measurement is ready to start (bit 2 = 1) but the Main Gate has not opened (bit 4 = 0).
XX011XXX	Input signal lost during measurement. The measurement is ready to stop (bit 3 = 1) but the main gate is still open (bit 4 = 1)

(X = don't care)

NOTE: SRQ is normally not used for these bits.

Ready for triggering indicates that all preparations for a measurement is completed. The preparation time depends on selected functions. It can be up to 700 ms (when auto triggering is selected).

If triggered mode is selected, the counter waits to be triggered, otherwise it proceeds with the measurement. You can have the SRQ-mask set for SRQ at ready for triggering. This way the controller knows when it is possible to trigger the counter.

Measuring result ready indicates that the measurement and calculation of the result is completed and that the result is present in the output buffer. If SRQ for is selected for this event, or Free-run is OFF, the counting will stop until the controller has read the result.

Programming error is generated if the counter receives messages with illegal syntax or values out of its range.

If 'Programming error' is generated, the counter will stop measuring. It will continue to receive and store correct programming messages and use them when the error status is reset and a new measurement starts.

Correct the program before resetting the status message.

Use one of the following bus commands to reset the status byte:

Go to local (GTL), Device clear (DCL) or selective device clear (SDC).

Any of the following messages will have the same effect on the counter:

D, FNC?, MEAC?, INPA?, INPB?, ID? or BUS?.

A serial poll will also reset the status message if the SRQ mask is set for 'SRQ at Programming error'.

Hardware fault is generated when the counter displays the codes described in 'Error codes' in the 'Operating instructions' in this manual.

Time-Out is generated when the set time-out period has elapsed.

Possible status messages

Normal measurement

The status byte changes as follows during a normal measurement:

0, 2, 6, 22, 30, 14, 15, 0,

Decimal *	Binary 76543210	Important bits (X = don't care)	Comment
0	00000000		Preparing a measurement or, High-speed dump or Volt measurements in progress.
2	00000010	XX0XXX1X	Preparations ready. If Free-run OFF, waiting for triggering (GET).
6	00000110	XX0XX1XX	Measuring start enable.
22	00010110	XX01XXXX	Main-Gate open, measurement in progress.
30	00011110	XX0X1XXX	Measuring stop enable.
14	00001110		Calculating the measuring result.
15	00001111	XX0XXXX1	Measuring result ready.

Error conditions

Decimal *	Binary 76543210	Important bits (X = don't care)	Comment
33	00100001	XX1XXXX1	Programming error.
34	00100010	XX1XXX1X	Hardware fault.
36	00100100	XX1XX1XX	Time-out.

* If Service request (SRQ) is enabled for an event, the decimal value of the status message for that event will be increased by 64. The reason for this is that bit 6 will be set to one at the same time as the bit indicating the event.

Output mode

Setting the output mode selects the format in which the counter will output measuring results to the controller. Select output mode by sending OUTM <number> where <number> is a decimal value between 0 and 4 depending on the selected output mode.

<number>	High-speed dump	Output format	MTCXO compensation
0	OFF	NORMAL	ON
1	OFF	SHORT	ON
2	OFF	NORMAL	OFF
3	OFF	SHORT	OFF
4	ON	FOR HIGH SPEED DUMP	OFF **

Default <number> is 0, when switching to local and back again, the <number> will be reset to 0.

The MTCXO compensation can be switched off to increase the measuring speed, providing a result with five digits accuracy is sufficient. The time gained will be up to 400 ms/measurement.

** Must be in the end of a program message.

Output format

Normal

When you select normal output format, the output will be as follows:

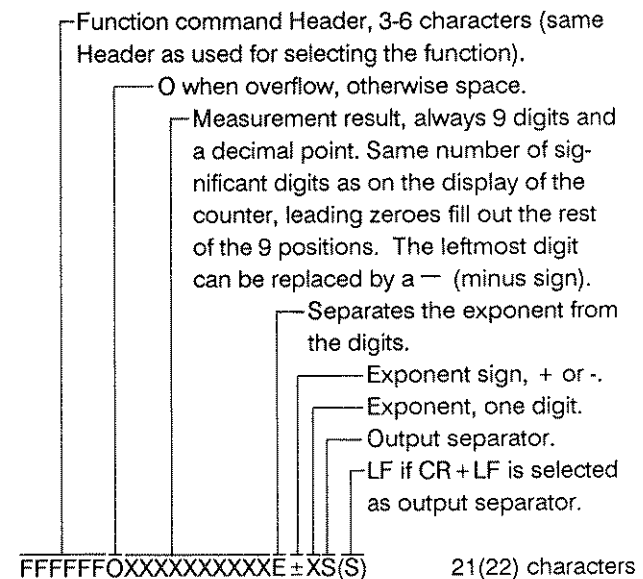

EXAMPLE: Normal operation:

PER 000001.667E-4

Overflow: PER 09.99999999E+9

Short

Short format means that function command and leading zeros are not sent to the controller. When you select short output format, the number of digits may vary depending on the measurement result. The example below shows a result with five significant digits:

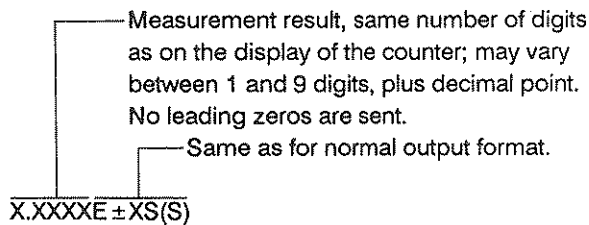

EXAMPLE: Normal operation: 1.667E-4
Overflow: 9.99999999E+9

High-speed dump

The most time-consuming part of a measuring cycle is calculating the result. The calculations limit the number of possible results/second to about 5, even when the Measuring-time is short.

When however High-Speed dump is selected all calculations are left to the controller instead, and the counter can concentrate on measuring at a rate of over 100 measurements/second.

High-speed dump cannot be used for voltage measurements nor for Totalize manually. MTCXO compensation is not possible.

Starting

If triggered mode is OFF

When High-speed dump is programmed the counter will immediately start transmitting results, so the OUTM 4 command must always be placed at the end of the program message.

If triggered mode is ON

After receiving OUTM 4 the counter waits for bus command GET before it starts.

NOTE: The minimum time between OUTM 4 and GET is 70 ms.

Stopping

Any programming command from the controller will end High-Speed dump.

NOTE: The Power-switch is the only front panel control that will stop High-Speed dump, the LOCAL-button will not have any effect.

Output format

The output format will always be two letters followed by 12 hexadecimal digits. The two letters will tell the controller how to evaluate the twelve hex-digits, which represent the contents in the internal registers of the counter.

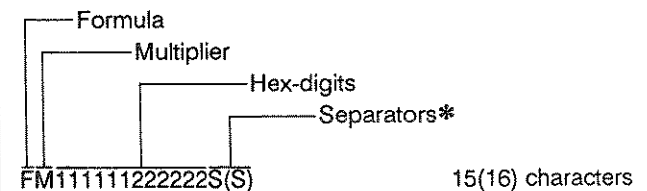

* The counter cannot signal EOI together with the output separator when High-speed dump is selected.

Hex-digits

All 12 digits together represent register 3.

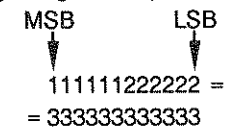

When the digits are divided into two groups, the first six digits represents register 1 and the last six digits represent register 2.

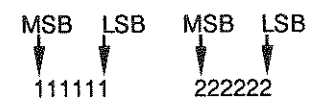

Formula

Depending on the selected measuring function different calculations must be made to convert the register contents to readable measuring results.

The first letter (F) in the output data indicates which formula you must use.

If 'F' = Use this formula

C $\frac{\text{Reg. 2} \cdot 10^7}{\text{Reg. 1}}$

F Reg. 3

G $\frac{\text{Reg. 2}}{\text{Reg. 1}}$

I $\frac{\text{Reg. 1} \cdot 10^{-7}}{\text{Reg. 2}}$

J $\text{Reg. 3} \cdot 10^{-7}$

K $\frac{\text{Reg. 2} \cdot 10^{-7}}{\text{Reg. 1}}$

Multiplier

The second letter (M) in the output data represents a multiplier which you must multiply the results by before presenting it.

If 'M' = Multiply results by:

H 60

L 256

N 0.1

O 10

P 1

EXAMPLE 1:

The following HP-85 program sets up a High-Speed dump Single-period measurement.

```
OUTPUT 710;"PER A, MTIME 0"
```

```
ENTER 710;A$
```

```
A$
```

```
PER 000001.667E-4
```

```
OUTPUT 710;OUTM 4
```

```
ENTER 710;A$
```

```
A$
```

```
JP000000000683
```

'J' means that you must use formula J which is:
 $\text{Reg. 3} \cdot 10^{-7}$.

000000000683 is the hex-contents of register 3. The register contents must be converted to a decimal number and entered in the formula;

$$683_{\text{Hex}} = 6 \cdot 16^2 + 8 \cdot 16 + 3 = 1667_{\text{decimal}}$$

The result is $1667 \cdot 10^{-7}$, which you must multiply by "Multiplier P", which is 1, to get the measuring result.

$$1667 \cdot 10^{-7} \cdot 1 = 1.667 \cdot 10^{-4} \text{ s} = 166.7 \mu\text{s}$$

EXAMPLE 2:

The following HP-85 program sets up a High-Speed dump Frequency A measurement with 1 s Measuring-time.

```
OUTPUT 710;"FREQ A,MTIME 1"
ENTER 710;A$
```

```
A$
FREQ      006.000006E3
```

```
OUTPUT 710;OUTM 4
ENTER 710;A$
```

```
A$
CO98555B000257
```

Formula 'C' is: $\frac{\text{Reg. 2} \cdot 10^7}{\text{Reg. 1}}$

98555B is the hex-contents of register 1, and 000257 is the hex-contents of register 2. Both register contents must be converted to decimal numbers and put into the formula;

$$\frac{(2 \cdot 16^2 + 5 \cdot 16 + 7) \cdot 10^7}{9 \cdot 16^5 + 8 \cdot 16^4 + 5 \cdot 16^3 + 5 \cdot 16^2 + 5 \cdot 16 + 11} = 600.0006209..$$

This number is multiplied by multiplier 'O' to get the measuring result:

$$600.0006209 \cdot 10 = 6000.006209 = 6.000006209 \cdot 10^3 \text{ Hz.}$$

How many digits are significant?

Select the formula for 'LSD displayed' in the 'Specifications'. There are different formulas for different measurements.

Frequency:

$$\text{LSD displayed: } \frac{2.5 \cdot 10^{-7} \cdot \text{FREQ}}{\text{Measuring-time}}$$

$$\frac{2.5 \cdot 10^{-7} \cdot 6000...}{1} = 0.0015$$

LSD = 0.001 Hz

The result is $6.000006 \cdot 10^3$ Hz

Bus Learn

- 1) Set the counter to LOCAL and select the functions you want from the front panel.
- 2) If required, set the counter to Remote and program special bus-functions from the controller.
- 3) Check that the counter/controller performs the intended functions.
- 4) If it does, send the five queries from the controller to the counter and store the responses in the controller for later use.

These are the five queries:

Query	Response	Max No. of characters
FNC?	Functions setting; e.g. FREQ A	9
MEAC?	Measurement control; MTIME < number >,FRUN ON TOUT < number >	20 9
INPA?	Input A settings; TRGSLP POS,ATT OFF COUPL AC,AUTO OFF*	18 17
INPB?	Input B settings; TRGSLP POS,ATT OFF COUPL DC,COM OFF*	18 16
BUS?	Bus interface commands; MSR < number >,OUTM < number > EOI OFF,SPR < number >	19 19 16 15

As you can see, the responses are the same commands as you use for normal programming. So if you have to change anything in a program made using bus learn, or add functions which are not selectable from the front panel, these program messages can easily be edited in the controller.

NOTE: MEAC? and BUS? result in a response sent as two lines, each terminated by the selected separator. INPA? and INPB? result in a response sent as a three line messages.

NOTE: The counter will stop measuring until all lines of the response have been read or the response has been terminated.

NOTE: The query command must always be the last command in a program message.

* If AUTO or COM is switched ON, the responses to INPA? and INPB? must be interpreted in a different way, see 'Selecting Input settings'.

Terminating a response

It is not necessary to read all output lines. Any program message will terminate the response.

Programming data out

Any one of the queries used for Bus Learn can be used to ask the counter about its current setting, see 'Bus Learn' above.

What happens when I switch to local?

Switching to LOCAL causes the counter to adapt the settings indicated on the display, see 'How to select function'. This means that the counter will never have settings in LOCAL which are not possible to set via the front panel.

When switching to remote again, the LOCAL-setting will remain. Bus-functions like SRQ mask, output separator, EOI, etc. will not be altered by switching to LOCAL and back again.

Summary of bus commands

Function selecting commands

- FREQ A Frequency measurement on Input-A.
- FREQ B Frequency measurement on Input-B.*
- FREQ C Frequency measurement on Input-C.
- PER A Period on Input-A.
- TIME A,B Time interval A to B.
- TIME B,A Time interval B to A.*
- TOTG A,B Totalize A, gated by Input-B.
- TOTG B,A Totalize B, gated by Input-A.*
- TOTS A,B Totalize A, started and stopped by B.
- TOTS B,A Totalize B, started and stopped by A.*
- TOTM A Totalize A, start/stop by GATE OPEN/-CLOSED on the bus.
- TOTM B Totalize B, start/stop by GATE OPEN/-CLOSED on the bus.*
- RATIO A,B No. of pulses on A ÷ No. of pulses on B.
- RATIO B,A No. of pulses on B ÷ No. of pulses on A.*
- RATIO C,A No. of pulses on C ÷ No. of pulses on A.*
- RATIO C,B No. of pulses on C ÷ No. of pulses on B.*
- VMAX A Positive peak voltage on Input-A.
- VMIN A Negative peak voltage on Input-A.
- VMAX B Positive peak voltage on Input-B.*
- VMIN B Negative peak voltage on Input-B.*
- FNC? Output the current function setting.***

Input setting commands

- INPA Selects Input-A.
- INPB Selects Input-B.
- TRGSLP POS Triggering on positive slope.
- TRGSLP NEG Triggering on negative slope.
- COUPL AC AC coupling.
- COUPL DC DC coupling.
- COM ON A and B common via Input-A.
- COM OFF A and B separated.
- SENS <num> <num> = 1 gives 20 mV sensitivity
<num> = 2 gives 50 mV sensitivity
<num> = 3 gives 100mV sensitivity.
- TRGLVL ± <num> Trigger level, +5.10 V to -5.10 V.
± = polarity sign. <num> = level in Volt.
- AUTO ON Automatic trigger level selection.**
- AUTO OFF Trigger level selection via bus.**
- ATT OFF Attenuation • 1.
- ATT ON Attenuation • 10.
- INPA? Output the current Input-A settings.***
- INPB? Output the current Input-B settings.***

Measurement control commands

- GATE OPEN Starts the totalizing in TOTM A and TOTM B
- GATE CLOSE Stops totalizing.
- MTIME <num> Set Measuring-time. <num> = 0.01-10 s. 0 = SINGLE
- FRUN ON Selects Free-Run.
- FRUN OFF Selects Triggered mode.
- TRIG OFF Selects Free-Run.
- TRIG ON Selects Triggered mode.
- TOUT <num> Sets Time-Out. <num> = 0.1 - 25.5 s. 0 = Time-Out OFF.
- MEAC? Output the current Measurement control settings.***

Bus related commands

OUTM <number>

<number>	High-speed dump	Output format	MTCXO compensation
0	OFF	NORMAL	ON
1	OFF	SHORT	ON
2	OFF	NORMAL	OFF
3	OFF	SHORT	OFF
4	ON	FOR HIGH SPEED DUMP	OFF***

- MSR <num> Sets SRQ-mask, see 'Service request'.
- EOI ON Selects EOI-mode ON.
- EOI OFF Selects EOI-mode OFF.
- SPR <num> Select output separator, see 'Output separators'.
- X Device trigger, starts a new measurement.***
- D Device clear, returns to default settings.
- BUS? Output the current bus related settings.***
- ID? Output identity and which options are installed.***

* Not available in LOCAL mode.

** Affect both inputs independent of INPA/INPB.

*** This command must be placed at the end of a program message.

Programming examples

For HP-85 controller

This program illustrate high measuring rate obtained with High-speed dump.

The actual measuring function is selected by the user in Local-mode. When the program runs, two beep's can be heard from the HP-85, Between these beep's, the counter performs 500 measurements and the result of each measurement is transferred from the counter to the HP-85.

The output rate is approximately 125 readings/second in this example.

```

10 ! DEMO PROGRAM DUMP MODE
20 ! PM6666 WITH HP85 AS
30 ! CONTROLLER
40 ! DUMP MODE WITH FREE RUN ON
50 CLEAR
60 DIM Z#[7508] ! BUFFER FOR 50
  0 MEASUREMENTS WITH 15 BYTES
70 DIM B#[14]
80 IOBUFFER Z#
90 LOCAL 710
100 DISP "SELECT FUNCTION IN LOC
  AL MODE!"
110 DISP "MEASURING TIME WILL BE
  "
120 DISP "SELECTED BY HP85 (SING
  LE)!"
130 DISP "ANSWER Y WHEN READY TO
  START!"
140 INPUT A#
150 IF A#<>"Y" THEN 130
160 DISP "MAKE 500 MEASUREMENTS"
170 OUTPUT 710 ;"TRIG OFF,MTIME
  0.0UTM 4"
180 BEEP
190 E=TIME
200 TRANSFER 710 TO Z# FHS ; COU
  NT 7500
210 F=TIME
220 BEEP
230 DISP "READY! ELAPSED TIME:";
  F-E;"s"
240 ! SHOW 5 RESULTS"
250 DISP "FIRST 5 RESULTS:"
260 FOR K=1 TO 5
270 ENTER Z# ; B#
280 ! GET FORMULA CHARACTER
290 F#=B#[1,1]
300 ! GET MULTIPLYER CHARACTER
310 M#=B#[2,2]
320 ! EVALUATE REGISTER 1
330 R1=0
340 FOR I=3 TO 8
350 S=NUM(B#[I,I])-48
360 IF S>=10 THEN S=S-7
370 R1=R1*16+S
380 NEXT I
390 ! EVALUATE REGISTER 2

```

```

400 R2=0
410 FOR I=9 TO 14
420 S=NUM(B#[I,I])-48
430 IF S>=10 THEN S=S-7
440 R2=R2*16+S
450 NEXT I
460 ! EVALUATE RESULT
470 IF F#="C" THEN R=10000000*R2
  /R1
480 IF F#="F" THEN R=R1*16^6+R2
490 IF F#="G" THEN R=R2/R1
500 IF F#="I" THEN R=.0000001*R1
  /R2

510 IF F#="J" THEN R=.0000001*(R
  1*16^6+R2)
520 IF F#="K" THEN R=.0000001*R2
  /R1
530 IF M#="H" THEN R=R*60
540 IF M#="L" THEN R=R*256
550 IF M#="N" THEN R=R/10
560 IF M#="O" THEN R=R*10
570 IF M#="P" THEN R=R*1
580 DISP B#,R
590 NEXT K
600 LOCAL 710
610 END

```

Example of a result:

```

MEASURING TIME WILL BE
SELECTED BY HP85 (SINGLE)!
ANSWER Y WHEN READY TO START!
?
Y
MAKE 500 MEASUREMENTS
READY! ELAPSED TIME: 3.927 s
FIRST 5 RESULTS:
JP0000000000031          .0000049
JP0000000000031          .0000049
JP0000000000030          .0000048
JP0000000000031          .0000049
JP0000000000031          .0000049

```

5053

For IBM PC with PM 2201

Example 1

The following example runs on an IBM compatible PC equipped with Philips PM 2201 GPIB interface. The installation and starting up of the PC program is not described, only the application program. Line 1 to 100 must contain the declaration described in the PM 2201 manual.

The program sets up the counter for 10 Period A measurements and presents the average result on the screen.

```

100 'DEMO PROGRAM (NO 1)
110 'PM6666 AND IBM PC
120 'WITH PM2201 GPIB INTERFACE
130 'AS CONTROLLER
140 CLS 'CLEAR SCREEN
150 AD=7 'ADAPTOR NUMBER
160 ADDR=710 'COUNTER ADDRESS
170 SC=1 'SYSTEM CONTROLLER
180 RES$ = SPACE$(25) 'RESULT
190 ACT = 0 '# READ CHARACTERS IN RES$
200 MAX = 24 'MAX CHARACTERS TO READ IN
    RES$
210 CALL IOINIT(AD,SC) 'INIT INTERFACE
220 TIME = 10 'TIMEOUT AFTER 10 SECONDS
230 CALL IOTIMEOUT (AD,TIME) 'SET TIME-
    OUT
240 CALL IOCLEAR(ADDR) 'SEND SDC
250 'SELECT PERIOD A, TRIGGERED MODE
260 'AND 1 S MEASURING-TIME
270 SEND$ = "PER A,TRIG ON,MTIME 1"
280 LENGTH=LEN(SEND$)
290 CALL IOOUTPUTS(ADDR,SEND$,LENGTH)
300 Z=0
310 'INPUT 10 SAMPLES
320 FOR i = 1 TO 10
330 CALL IOTRIGGER(ADDR) 'TRIGGER COUN-
    TER
340 CALL IOENTERS(ADDR,RES$,MAX,ACT)
    'READ RESULT
350 Z = Z + VAL(MID$(RES$,8,13))
360 NEXT I
370 PRINT "AVERAGE: ";Z/10;"S"
380 CALL IOLOCAL(ADDR) 'GO TO LOCAL
390 END
    
```

Example of a result:

```

AVERAGE:9.98004E-06 S
OK
    
```

Example 2

This program demonstrates how the PM 6666 performs the complete characterization of a pulse train. All important pulse parameters are automatically measured including pulse period, duration, rise and fall time, amplitude and DC-offset.

```

100 'DEMOPROGRAM (NO 2)
110 'PM6666 AND IBM PC WITH PM2201
120 'GPIB INTERFACE AS CONTROLLER
130 CLS 'CLEAR SCREEN
140 AD=7 'ADAPTOR NUMBER
150 ADDR=710 'COUNTER ADDRESS
160 SC=1 'SYSTEM CONTROLLER
170 CALL IOINIT(AD,SC) 'INIT INTERFACE
180 TIME=10 'TIMEOUT AFTER 10 SECONDS
190 CALL IOTIMEOUT(AD,TIME)
200 PRINT "PULSE CHARACTERIZATION"
210 PRINT "*****"
220 PRINT
230 'RANGE: 100 HZ -2 MHZ, -5V ... +5V
240 CALL IOCLEAR(ADDR) 'SEND SDC
250 S$="VMIN A" 'MEASURE MIN VOLTAGE LEVEL (AC)
260 GOSUB 1000
270 VMINA=0
280 CALL IOENTER(ADDR,VMINA) 'INPUT RESULT
290 S$="VMAX A,COUPL DC" 'MEASURE MAX VOLTAGE LEVEL (DC)
300 GOSUB 1000
310 VMAXD=0
320 CALL IOENTER(ADDR,VMAXD)
330 S$="COUPL AC" 'MEASURE MAX VOLTAGE LEVEL (AC)
340 GOSUB 1000
350 VMAXA=0
360 CALL IOENTER(ADDR,VMAXA)
370 VPP=VMAXA-VMINA 'CALCULATE VPP
380 OFFS=VMAXD-(VPP/2) 'CALCULATE DC OFFSET
390 S$="PER A" 'MEASURE PERIOD TIME
400 GOSUB 1000
410 PER=0
420 CALL IOENTER(ADDR,PER)
430 'MEASURE POSITIVE PULSE WIDTH
440 S$="COM ON,TIME A,B,INPB,TRGSLP NEG"
450 GOSUB 1000
460 PW=0
470 CALL IOENTER(ADDR,PW)
480 'MEASURE RISE TIME 10% - 90%
490 UL$=STR*(-.1*VPP+VMAXD) '90% LEVEL
500 LL$=STR*(-.9*VPP+VMAXD) '10% LEVEL
510 S$="AUTO OFF,INPA,COUPL DC,TRGLVL "+LL$
520 GOSUB 1000
530 S$="INPB,TRGSLP POS,TRGLVL "+UL$
540 GOSUB 1000
550 RT=0
560 CALL IOENTER(ADDR,RT)
570 'MEASURE FALL TIME 90% - 10%
580 S$="TIME B,A,TRGSLP NEG,INPA,TRGSLP NEG"
590 GOSUB 1000
600 FT=0
610 CALL IOENTER(ADDR,FT)
620 PRINT "PERIOD TIME [S]:";
630 PRINT USING "##.###^";PER
640 PRINT "PULSE WIDTH [S]:";
650 PRINT USING "##.###^";PW
660 PRINT "RISE TIME [S] :";
670 PRINT USING "##.###^";RT
680 PRINT "FALL TIME [S] :";
690 PRINT USING "##.###^";FT
700 PRINT "Vpp [V] :";
710 PRINT USING "##.###";VPP
720 PRINT "DC OFFSET [V] :";
730 PRINT USING "##.###";OFFS
740 END
1000 L=LEN(S$) 'LENGTH OF STRING TO SEND
1010 CALL IOOUTPUTS(ADDR,S$,L) 'OUTPUT STRING
1020 RETURN
    
```

Example of the results:

```

PULSE CHARACTERIZATION
*****
PERIOD TIME [S]: 9.979E-06
PULSE WIDTH [S]: 4.981E-06
RISE TIME [S] : 7.089E-08
FALL TIME [S] : 7.083E-08
Vpp [V] : 3.16
DC OFFSET [V] :-1.16
OK
    
```

Example 3

This program example illustrates the 'program data out' feature of PM 6666. By asking a set of queries, the counter responds with its current setup. The output format of these answers to the queries is identical to the programming command format. The answers can be stored and used later for reprogramming (bus learn).

```

100 'DEMOPROGRAM (NO 3)
110 'PM6666 AND IBM PC WITH PM2201
120 'GPIB INTERFACE AS CONTROLLER
130 AD=7 'ADAPTOR NUMBER
140 ADDR=710 'COUNTER ADDRESS
150 SC=1 'SYSTEM CONTROLLER
160 CALL IOINIT(AD,SC) 'INIT INTERFACE
170 TIME=10 'TIMEOUT AFTER 10 SECONDS
180 CALL IOTIMEOUT(AD,TIME)
190 CLS 'CLEAR SCREEN
200 'ASK FOR AND PRINT PROGRAM DATA
210 PRINT "COUNTER SETTING:"
220 S$ = "FNC?"
230 GOSUB 520
240 A=1
250 GOSUB 550
260 S$ = "MEAC?"
270 GOSUB 520
280 A=2
290 GOSUB 550
300 S$ = "BUS?"
310 GOSUB 520
320 A=2
330 GOSUB 550
340 S$ = "INPA?"
350 PRINT "INPA:"
360 GOSUB 520
370 A=3
380 GOSUB 550
390 S$ = "INPB?"
400 PRINT "INPB:"
410 GOSUB 520
420 A=3
430 GOSUB 550
440 S$ = "ID?"
450 PRINT
460 PRINT "COUNTER TYPE:"
470 GOSUB 520
480 A=1
490 GOSUB 550
500 CALL IOLOCAL(ADDR) 'GO TO LOCAL
510 END
520 L=LEN(S$) 'LENGTH OF STRING TO SEND
530 CALL IOOUTPUTS(ADDR,S$,L) 'OUTPUT STRING
540 RETURN
550 FOR I = 1 TO A
560 MAX=25
570 ACT=0
580 RES$=SPACE$(25)
590 CALL IOENTERS(ADDR,RES$,MAX,ACT)
600 B$ = LEFT$(RES$,ACT)
610 PRINT B$;
620 NEXT I
630 RETURN

```

Example of a result:

```

COUNTER SETTING:
TIME      A,B
MTIME 10.00,FRUN  ON
TOUT 00.0
MSR 000,OUTM 000
EOI OFF,SPR 010
INPA:
TRGSLP NEG,ATT  ON
COUPL AC,AUTO OFF
TRGLVL +0.00,SENS 1
INPB:
TRGSLP POS,ATT OFF
COUPL DC,COM  ON
TRGLVL +0.00,SENS 1

```

```

COUNTER TYPE:
PM6666/436/12
Ok

```

Example 4

This program prompts the user to input a programming sequence. The sequence is then sent to the PM 6666 and the corresponding measuring result is read.

```

100 'DEMOPROGRAM (NO 4)
110 'PM6666 AND IBM PC WITH PM2201
120 'GPIB INTERFACE AS CONTROLLER
130 CLS 'CLEAR THE SCREEN
140 AD=7 'ADAPTOR NUMBER
150 ADDR=710 'COUNTER ADDRESS
160 SC=1 'SYSTEM CONTROLLER
170 CALL IOINIT(AD,SC) 'INIT INTERFACE
180 TIME=10 'TIMEOUT AFTER 10 SECONDS
190 CALL IOTIMEOUT(AD,TIME)
200 CALL IOCLEAR(ADDR) 'SEND SDC
210 PRINT "INPUT YOUR PROGRAMMING MESSAGE?"
220 PRINT "(TO QUIT THE PROGRAM, ANSWER *)"
230 LINE INPUT S$
240 L=LEN(S$) 'LENGTH OF STRING TO SEND
250 IF L<>1 GOTO 280
260 IF S*<>"*" GOTO 280
270 END
280 CALL IOOUTPUTS(ADDR,S$,L) 'OUTPUT STRING
290 'TO BE SURE, TRIGGER COUNTER!
300 CALL IOTRIGGER(ADDR)
310 'GET THE MEASURING RESULT
320 MAX=25
330 ACT=0
340 RES$=SPACE$(25)
350 CALL IOENTERS(ADDR,RES$,MAX,ACT)
360 PRINT
370 PRINT "RESULT READ AS: ";RES$
380 PRINT
390 GOTO 210

```

Let us as an example select Single Period measurements, without AUTO-triggering (gives faster operation).

```

INPUT YOUR PROGRAMMING MESSAGE?
(TO QUIT THE PROGRAM, ANSWER *)
PER A, MTIME 0, AUTO OFF

RESULT READ AS:   PER    00000009.9E-6

```

```

INPUT YOUR PROGRAMMING MESSAGE?
(TO QUIT THE PROGRAM, ANSWER *)

```

For IBM PC with IBM GPIB

This example runs on an IBM PC with an 'IBM General Purpose Interface Bus Adapter' instead of the Philips PM 2201 interface.

The following set of device parameters is suitable for a PM 6666 with address 10. The device parameters are set with the configuration program 'IBCONF', see the IBM adapter manual.

Device Name: COUNTER		DEVICE PARAMETERS		Number: D 0
DESCRIPTION	NEW VALUE	VALID RANGE		
Access Adapter Name?	GP1B0	± (GP1Bx)		
Primary GPIB Address?	0AH	[0H to 1EH]		
Secondary GPIB Address?	00H	[60H to 7EH; 0H disables]		
Timeout setting?	T10s	± (T10us to T1000s; NONE disables)		
EDS Byte?	0AH	[0H to FFH or '<character>]		
Terminate Read on EDS?	Yes	± (Yes or No)		
Send EDI with EDS byte?	No	± (Yes or No)		
Use 8-bit Compare on EDS?	No	± (Yes or No)		
Send EDI w/last Byte of Write?	Yes	± (Yes or No)		

Example of a result:

```
AVERAGE: 9.980418E-06 S
Ok.
```

Example 1

The following program sets up the counter for 10 Period A measurements and presents the average result on the screen.

```
100 'DEMO PROGRAM
110 'PM6666 AND IBM PC WITH IBM
120 'GPIB ADAPTOR AS CONTROLLER
130 CLS 'CLEAR SCREEN
140 'INIT
150 ADNAME$ = "COUNTER"
160 CALL IBFIND(ADNAME$,CNT%)
170 'SEND SDC
180 CALL IBCLR(CNT%)
190 'SELECT PERIOD A, TRIGGER MODE
200 'AND MEASURING TIME 1 S
210 WRT$ = "PER A,TRIG ON,MTIME 1"
220 CALL IBWRT(CNT%,WRT%)
230 'INPUT 10 SAMLES
240 Z=0
250 FOR I= 1 TO 10
260 CALL IBTRG(CNT%) 'TRIGGER COUNTER
270 CALL IBRD(CNT%,RD$) 'READ RESULT STRING
280 Z = Z + VAL(MID$(RD$,8,13))
290 NEXT I
300 PRINT "AVERAGE: ";Z/10;"S"
310 CALL IBLOC(CNT%) 'GO TO LOCAL
320 END
```

SPECIFICATIONS

Measuring functions

Frequency A or C (Frequency B via GPIB only)

Range,

Freq A: 0.1 Hz...120 MHz
Freq B: 0.1 Hz...12 MHz (only via GPIB)
Freq C: 70 MHz...1.3 GHz (option PM 9608B)

Mode: Reciprocal frequency counting.

LSD displayed: $\frac{2.5 \cdot 10^{-7} \cdot \text{FREQ}}{\text{Measuring-time}}$

Period A

Range: 8 ns... $2 \cdot 10^8$ s

Mode: Single period measurement (SINGLE) or period average measurement (at 0.2, 1 or 10 s Measuring-times).

LSD displayed:

SINGLE period measurement:
100 ns (TIME < 100 s)

$\frac{5 \cdot \text{PERIOD}}{10^9 \text{s}}$ (TIME > 100s)

Period average measurement:
 $\frac{2.5 \cdot 10^{-7} \cdot \text{PERIOD}}{\text{Measuring-time}}$

Ratio A/B (Ratio B/A, C/A or C/B only via GPIB)

Range: 0 and $1 \cdot 10^{-7}$... $2 \cdot 10^9$ (A/B)
0 and $1 \cdot 10^{-8}$... $2 \cdot 10^8$ (B/A)
 $0 \dots 1 \cdot 10^{15}$ (A/B SINGLE and B/A SINGLE)
 $8 \dots 6 \cdot 10^{10}$ (C/B) (C/A)

Frequency range:

Input A: 0.1 Hz...120 MHz (A/B)
0 Hz...12 MHz (B/A, C/A, A/B SINGLE)
Input B: 0 Hz...12 MHz
Input C: 70 MHz...1.3 GHz (option PM 9608B)

LSD displayed (Ratio A/B):
 $\frac{25}{\text{meas time} \cdot \text{FREQ B}}$ (0.2, 1 or 10 s Measuring-times)

LSD displayed (Ratio B/A):
 $\frac{2.5}{\text{meas time} \cdot \text{FREQ A}}$ (0.2, 1 or 10 s Measuring-times)

LSD displayed (A/B SINGLE, B/A SINGLE):
1 RATIO < 10^9
 $\frac{5 \cdot \text{RATIO}}{10^9}$ RATIO $\geq 10^9$

LSD displayed (Ratio C/A or C/B):
 $\frac{640}{\text{meas time} \cdot \text{FREQ A or B}}$

Time interval A-B (Time interval B-A via GPIB only)

Range:
100 ns... $2 \cdot 10^8$ s (SINGLE)
0 ns...20 s (average)

Mode: Single time interval (SINGLE) or time interval average measurements (at 0.2, 1 or 10 s Measuring-times)

LSD displayed:
SINGLE Time-interval measurement:
100 ns (TIME < 100 s)

$\frac{5 \cdot \text{TIME}}{10^9 \text{s}}$ (TIME > 100 s)

Time-interval average measurement:
 $\frac{2.5 \cdot 10^{-7} \text{s}}{N}$

Number of intervals averaged N:
 $\frac{\text{Measuring-time}}{\text{pulse repetition rate}}$

Min dead time from stop to start:
250 ns

Timing difference A-B channels:
4 ns max

NOTE: *Input signals must be repetitive and asynchronous with respect to the time base.*

Totalize A (Totalize B via GPIB only)

Range:

0...1 • 10¹⁵ with indication of K or M (Kilo-pulses or Megapulses). The result is truncated if out of display range.

Frequency range: 0 Hz...12 MHz

Pulse pair resolution: 8 ns

LSD displayed:

1 unit count (counts < 10⁹)
5 • counts/10⁹ (counts ≥ 10⁹)

Gated by B (A) mode:

Event counting on input A (B) during the duration of a pulse on input B (A).

Start/stop by B (A) mode:

Event counting on input A (B) between two consecutive pulses on input B (A).

Manual mode:

Event counting is controlled by the START/STOP button. Sequential start-stop counts are accumulated. RESET closes the gate and resets the Timer/Counter to zero.

Volt max/min A (Volt max/min B via GPIB only)

Range: -51 V...+51 V

Frequency range:

DC and 100 Hz...50 MHz (input A)
DC and 100 Hz...5 MHz (input B)

Resolution:

Input signals within ±5 V: 20 mV
Input signals outside ±5 V: 200 mV

Inaccuracy DC and 100 Hz...12 MHz(A) or ...1 MHz(B):

Input signals within ±5 V:
30 mV ± 1% of reading ± 3% of V_{pp}
Input signals outside ±5 V:
300 mV ± 3% of reading ± 3% of V_{pp}

Inaccuracy 12 MHz...50 MHz(A) or 1 MHz...5 MHz(B):

Input signals within ±5 V:
30 mV ± 10% of reading ± 10% of V_{pp}
Input signals outside ±5 V:
300 mV ± 10% of reading ± 10% of V_{pp}

Definitions

LSD displayed

LSD = Unit value of the least significant digit displayed. All calculated LSD:s (see section Measuring functions) should be rounded to the nearest decade (e.g 0.3 Hz is rounded to 0.1 Hz and 5 Hz to 10 Hz) and cannot exceed the 9th digit.

Resolution

Resolution = smallest increment between two measuring results on the display, due to the 1 count error.

Freq A, C, Period A and Ratio A/B:

Resolution can be 1 LSD unit or 2 LSD units.

$$\text{If; } \frac{\text{LSD} \cdot \text{Measuring-time}}{\text{FREQ or PERIOD}} < 10^{-7}$$

the resolution is 2 LSD units (30% probability).
Otherwise resolution is 1 LSD unit (70% probability).

Ratio A/B:

Resolution can be 1 LSD unit or 2 LSD units.

$$\text{If; } \frac{\text{LSD} \cdot \text{Measuring-time}}{\text{RATIO}} < \frac{10}{\text{FREQ A}}$$

the resolution is 2 LSD units (30% probability).
Otherwise resolution is 1 LSD unit (70% probability).

SINGLE Period A and SINGLE Ratio A/B:

Resolution equals 1 LSD unit.

Time A-B:

Resolution (95% confidence level) equals 1 LSD unit or 100 ns/√N, whichever is greatest.

Inaccuracy

Inaccuracy, i.e the relative error, depends on the following factors:

$$\pm \frac{\text{Resolution}}{\text{FREQ, PERIOD, RATIO or TIME}}$$

- ± relative trigger error
- ± relative time base error
- ± relative systematic error

Relative trigger error:

Freq A, Period A:

$$\pm \frac{\text{noise voltage A (V}_{pp})}{\text{signal slope A (V/s)} \cdot \text{meas time}}$$

Ratio A/B:

$$\pm \frac{\text{noise voltage B (V}_{pp})}{\text{signal slope B (V/s)} \cdot \text{meas time}}$$

Totalize A, gated or start stop by B:

$$\pm \frac{\text{noise voltage B (V}_{pp})}{\text{signal slope B (V/s)} \cdot \text{gate time B}}$$

Time A-B:

$$\pm \frac{\text{noise voltage A (V}_{pp})}{\text{signal slope A (V/s)} \cdot \text{TIME} \cdot \sqrt{N}}$$

$$\pm \frac{\text{noise voltage B (V}_{pp})}{\text{signal slope B (V/s)} \cdot \text{TIME} \cdot \sqrt{N}}$$

Relative time base error:

$$\pm \frac{\text{deviation from 10 MHz}}{10 \text{ MHz}}$$

Relative Time A-B systematic error:

Inaccuracy caused by timing difference between A and B channels < ±4 ns/TIME.

Input specifications

Input-A and Input-B

Frequency range:

0 Hz...120 MHz (Typically up to 160 MHz with 60 mV_{RMS} input signal.)

Sensitivity,

DC coupled;

Sine: 20 mV_{RMS}, 0 Hz...30 MHz
40 mV_{RMS}, 30 MHz...120 MHz

Pulse: 60 mV_{pp}, 0 Hz...30 MHz
110 mV_{pp}, 30 MHz...120 MHz

AC coupled;

Sine: 20 mV_{RMS}; 20 Hz...30 MHz
40 mV_{RMS}; 30 MHz...120 MHz

Sensitivity is selectable in 6 steps; 20 mV, 50 mV, 100 mV, 200 mV, 500 mV and 1 V_{RMS} (sine); nominal.

The sensitivity is decreasing to 60 mV_{RMS} at 160 MHz typically.

Coupling: AC- or DC- coupled, switch selectable.

Impedance: 1 MΩ // 35 pF, independent of "COM B via A" switch setting.

Attenuation: x1 or x10, switch selectable or AUTO.

Trigger levels:

DC coupled:

+51 V...-51 V, adjustable via up/down control.

AC coupled:

0 V fixed or auto level.

Trigger level resolution:

20 mV; signals within ±5 V
200 mV; signals outside ±5 V

Trigger level setting accuracy: ±10 mV ±1% of setting

AUTO trigger level:

Trigger level on input A (and B when required) is automatically set to 50% of input signal amplitude.

Frequency range: 100 Hz...120 MHz

Trigger indicators: Tri-state LED-indicators;

On: Signal above set trigger level.

Off: Signal below set trigger level.

Blinking: Triggering occurs.

Trigger slopes: Positive or negative.

Channel input: Separate A and B, or A and B common via input-A.

Maximum voltage:

350 V (DC + AC_{peak}) between 0 and 440 Hz, falling to 8 V_{RMS} at 1 MHz.

Input-C (option PM 9608,-08B or PM 9615)

Frequency range:

PM 9608B:	70 MHz ... 1.3 GHz
PM 9608:	100 MHz ... 1.1 GHz
PM 9615:	70 MHz ... 1.0 GHz

Coupling: AC

Operating input voltage range:

PM 9608B:	10 mV _{RMS} ...12 V _{RMS} , 70 MHz...900 MHz
	15 mV _{RMS} ...12 V _{RMS} , 900 MHz...1.1 GHz
	40 mV _{RMS} ...12 V _{RMS} , 1.1 ... 1.3 MHz

PM 9608:	10 mV _{RMS} ...12 V _{RMS} , 100 MHz...900 MHz
	15 mV _{RMS} ...12 V _{RMS} , 900 MHz...1.1 GHz

PM 9615:	15 mV _{RMS} ...12 V _{RMS} , 70 MHz...100 MHz
	10 mV _{RMS} ...12 V _{RMS} , 100 MHz...1.0 GHz

AM tolerance:

98%, minimum signal must exceed minimum operating input voltage requirement

Impedance: 50 Ω nominal, VSWR < 2

Maximum voltage without damage:

12 V_{RMS}, overload protection with PIN diodes.

Ext reference input

The input automatically detects when a suitable external reference signal is connected. The use of an external reference signal is indicated on the display.

Input frequency:	10 MHz ± 0.1 MHz
Coupling:	AC
Sensitivity:	500 mV _{RMS}
Input impedance:	approx. 300 Ω at 10 MHz
Max input voltage:	15 V _{RMS}

General information

Power requirements

Line voltage:

115 or 230 V_{RMS} ± 15%;
46...440 Hz, (<24 VA incl. all options).

Safety:

in accordance with IEC 348 CLASS I and CSA 556B.

Line interference:

below VDE 0871 B and MIL STD 461.

Battery unit: See PM 9605 option.

Dimensions and weight

Width:	186 mm
Height:	88 mm
Depth:	270 mm
Weight,	
<i>net:</i>	2.4 kg
<i>shipping:</i>	3.2 kg

Cabinet:

The counter is housed in a metal cabinet, to minimize electro-magnetic interference and achieve good mechanical stability.

Environmental conditions

Temperature,

Operating: 0°C... +50°C
Storing: -40°C... +70°C

Altitude,

Operating: 5000 m (53.3 kN/m²)
Storing: 15000 m (15.2 kN/m²)

Humidity,

Operating: 10%...90% RH, no condensation
Storing: 5%...95% RH

Vibration test:	According to IEC 68Fc
Bump test:	According to IEC 68Eb
Handling test:	According to IEC 68Ec

Display

Read out:

9 digit LCD display with unit indication.

Unit indication:

MHz, kHz, Hz, mHz, ks, s, ms, μ s, ns, M, k, m, μ and n.

GATE indicator:

Indicates that the counter is busy measuring.

REMOTE indicator:

Indicates when control over the counter is taken over by an installed GPIB interface PM 9604.

Cursor:

Indicates selected measuring function, selected Measuring-time, input triggering, display hold and whether an external reference frequency is in use.

Time base (Crystal oscillator)

Choice of:

- Uncompensated crystal oscillator (order no PM 6666/.1.)
- MTCXO, i.e. Mathematically Temperature Compensated Crystal Oscillator (order no PM 6666/.3.). The MTCXO can be ordered separately for later upgrading of the counter (option PM 9607).

MTCXO working principle:

The temperature of the crystal is measured. The built-in microprocessor calculates the frequency deviation for that particular temperature from a stored table. The measuring result is mathematically corrected for the time-base frequency temperature error, before being displayed. The correction is switched off when SINGLE is selected to increase the number of measurements/second. This may introduce an additional time base error of $< 1 \cdot 10^{-5}$.

Oscillator version:

	Uncompensated	MTCXO
Stability against:		
Ageing per month	$< 5 \cdot 10^{-7}$	$< 1 \cdot 10^{-7}$
per year	$< 5 \cdot 10^{-6}$	$< 5 \cdot 10^{-7}$
Temperature changes 0...50°C	$< 1 \cdot 10^{-5}$	$< 2 \cdot 10^{-7}$
Line voltage changes 10%	$< 1 \cdot 10^{-8}$	$< 1 \cdot 10^{-9}$

Auxiliary functions

Power on/off

Switches counter power on/off. At power up a self-test is made and the counter is set to default settings.

Default settings,

Function:	FREQ A
Measuring-Time:	0.2 s
Coupling:	AC on Input-A DC on Input-B
Trigger level:	Auto
Trigger slope:	Positive on A and B.

Reset

The RESET-button has three functions:

1. RESET Starts a new measurement. The settings are not changed.
2. LOCAL Makes the counter go to LOCAL operation, when in remote operation (unless Local Lock-Out is programmed).
3. START/STOP Opens/closes the gate in TOTALIZE A or B manual mode.

Measuring-time

A Measuring-time of 0.2 s, 1 s, 10 s or SINGLE can be selected.

NOTE: When SINGLE is selected together with PERIOD, RATIO or TIME, the result is a single cycle measurement, but SINGLE together with FREQUENCY results in a fixed 3 ms Measuring-time.

Measuring rate:

Approx. 5 measurements/s. Approx. 2 measurements/s when AUTO trigger level is switched on.

Display time:

Normally the display time equals the set Measuring-time. When SINGLE is selected, a display time of 0.1 seconds is used.

Displ hold

The result of the current measurement will be frozen on the display. A new measurement starts when RESET button is pressed.

Optional accessories

GPIB-interface, PM 9604

Mounting:

Inside counter cabinet.

Interface functions:

SH1, AH1, T5, L4, SR1, RL1, DC1, DT1, E2

Address setting:

Switch selectable at rear panel between 0 and 30.
Factory preset at 10.

Programmable device functions:

Measuring functions
Measuring-time
Trig level offset selection
Trigger slope
Manual Totalize gate control
Output separator selection
Device clear
Device trigger
High-speed dump
MTCXO on/off
Short output format
Free run/Triggered measurements
Set SRQ-mask
Program data out queries
Device identity query

Programming code format:

7-bit ISO code (ASCII) characters. Both upper and lower case characters are accepted.

Input separator:

The counter accepts the following characters as separators:

ETX, ETB, CR, LF, ' '(space) ', '(comma),
':(colon) '; '(semicolon).

Output data separator:

Default separator at power-on is LF. The separator can be programmed to be any non printable ASCII-code with decimal equivalent 0-31, except 27 (ESC).

In addition the combination 13+10 (CR+LF) can be programmed. The EOI-line can be programmed to be active together with the last output byte sent.

Output format:

Measuring result is sent as:

FFFFFFOXXXXXXXXXXE±XS(S) 21(22) characters.

FFFFFF= Function code 3...6 characters
O = Normally space. O on overflow
X...X = Measuring result
E = Exponent pointer
± = Exponent sign (+ or -)
X = Exponent value 0...9
S = Selected separator
(S) = Second separator LF only if output separator CR + LF has been selected.

When you select 'Short output format' FFFFFFF and leading zeroes are omitted.

High-speed dump

The contents of the counting registers are transferred to the controller, without being processed by the counter. The processing must be done in the controller instead. Max output rate is approximately 100 readings/s.

The output format is FMXXXXXXXXXXS(S) where F is calculation formula, M is multiplier, X..X = 12 hex-digits representing the register contents, and S(S) is the set output separator.

Ranges:

Same as for normal operation, with the following exceptions:

<i>Frequency;</i>	Max measuring time: 1 s
<i>Period, average;</i>	Max measuring time: 1.4 s
<i>Time interval, average;</i>	0 ns...1.6 s Max measuring time: 4 s
<i>Ratio A/B:</i>	0 and $6 \cdot 10^{-7}$... $1.6 \cdot 10^8$
<i>Ratio B/A:</i>	0 and $6 \cdot 10^{-8}$... $1.6 \cdot 10^7$
<i>Ratio C/A, C/B:</i>	$8 \cdot 10^9$

Max data output rate:

Normal mode gives >5 readings/s. High-speed dump gives > 100 readings/second,. The highest output rate is obtained at SINGLE Measuring-time.

Output time for measuring data:

Normal operation: Approx. 10 ms (21 bytes)

High-speed dump: Approx. 4 ms (15 bytes)

Response time for addressing:

Approx. 5 μ s

Response time for trigger command (GET):

Normal operation: Approx. 10 ms

High-speed dump: Approx. 2 ms

Response time for serial poll:

Approx. 1.5 ms

Input buffer size: 28 bytes**Typical read time for programming data:**

Approx. 1 ms/byte (unless input buffer is full)

Battery unit PM 9605

The PM 9605 is a rechargeable battery unit for mounting inside the counter. The unit contains a standard 6 V sealed lead-acid battery and an automatic battery charger.

Battery capacity (20°C):

Approx 15 Wh

Operating time when battery powered:

2 hours of continuous operation.

Recharging time:

7 hours to approx 75% of full capacity.

Battery protection:

Overcharge protection and auto-shut-off total discharge protection.

Temperature,

Operating: 0...+40°C

Storage: -40...+50°C

Weight: 0.8 kg**Rack-mount kit PM 9606**

The PM 6666 can be installed in a standard 19" rack using the rack-mount kit PM 9606. One counter PM 6666 can be installed together with a second instrument with a half 19-inch width.

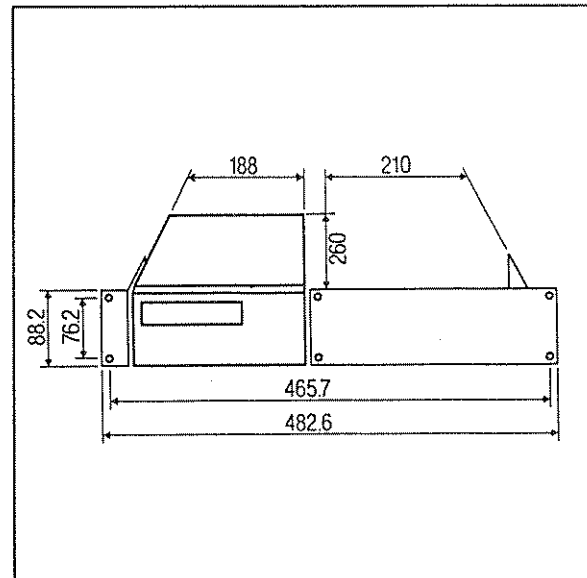

Figure 16. Size of the Rack-mount kit.

High stability time-base PM 9607

See specifications for optional MTCXO time-base.

HF-input PM 9608, -08B, -15

See specifications for optional Input-C.

Ordering information

Versions

The PM 6666 ordering number consists of the basic type number and a 3 digit XYZ suffix, specifying the required con-figuration.

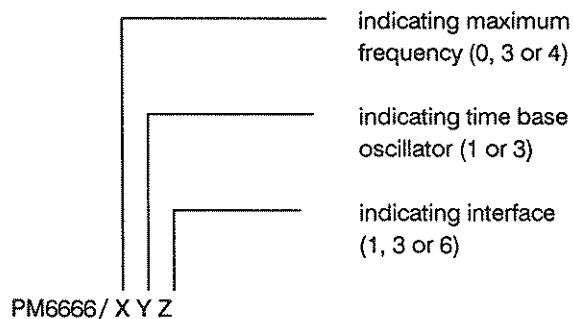

Type No.	Description
PM 6666/011	Universal frequency counter, 120 MHz frequency range, uncompensated oscillator $5 \cdot 10^{-7}$ /month, incl operators' manual.
PM 6666/3..	As above, but including 1.0 GHz HF-input PM 9615.
PM 6666/4..	As above, but including 1.3 GHz HF-input PM 9608B.
PM 6666/.3.	As above, but including crystal oscillator PM 9607 (MTCXO).
PM 6666/..3	As above, but including battery unit PM 9605.
PM 6666/..6	As above, but including GPIB interface PM 9604.

Example: PM 6666/416 means a PM 6666 frequency counter, including both an 120 MHz and an 1.3 GHz input channel, an uncompensated oscillator and a GPIB interface.

Options and accessories

PM 9604	GPIB-interface
PM 9605	Battery unit
PM 9606	Rack-mount kit
PM 9607	MTCXO time-base
PM 9608	1.1 GHz HF-input (replaced by PM 9608B)
PM 9608B	1.3 GHz HF-input
PM 9609	Carrying case
PM 9615	1.0 GHz HF-input (Only available in some contries)

PM 2296/50	IEEE to IEC adapter
PM 2295/05	IEEE cable, 0.5 m
PM 2295/10	IEEE cable, 1 m
PM 2295/20	IEEE cable, 2 m

PM 8911	1.5 GHz, 500 Ω probe set, 1:10
PM 8922	120 MHz, 1 M Ω probe set, 1:1 and 1:10
PM 8943	650 MHz, 1 M Ω FET probe set
PM 9581	50 Ω termination, 3 W
PM 9585	50 Ω termination, 1 W

All options mentioned above can be installed by the customer.

NOTE: The GPIB interface PM 9604 and the battery unit PM 9605 can not be installed together in a PM 6666 counter.

Manuals

9499 460 12611	Operators' Manual
9499 460 12618	Operators' Manual (German)
9499 460 12632	Operators' Manual (French)
9499 465 01011	Service Manual
9499 460 12711	GPIB Pocket Guide

APPENDIX 1

Checking the sensitivity of counters

Introduction

The sensitivity of a counter is normally specified as the minimum signal voltage on which the input of the counter will trigger correctly.

When you use a signal-source with an output-impedance of $50\ \Omega$, constant-output-amplitude, and the counter has a $50\ \Omega$ input-impedance, the input signal of the counter is in theory independent of the cable length. However, if the input impedance deviates from $50\ \Omega$ there will be standing wave reflections which will cause changes in the amplitude of the signal between the signal-source and the counter input.

Two factors determine the magnitude of the changes, i.e. frequency and capacitive load.

EXAMPLE: For a $1\ \text{M}\Omega//35\ \text{pF}$ input, the $35\ \text{pF}$ parallel capacitance is approximately equal to a $50\ \Omega$ capacitive load at $100\ \text{MHz}$.

Consequently, it is of the utmost importance to know how sensitivity is measured.

Recommended instruments

- Signal-source with a $50\ \Omega$ output impedance.
- $\geq 350\ \text{MHz}$ oscilloscope with a $50\ \Omega$ input impedance.
- BNC T-piece.
- Two BNC-cables, one short and one long.

High-impedance inputs ($1\ \text{M}\Omega$)

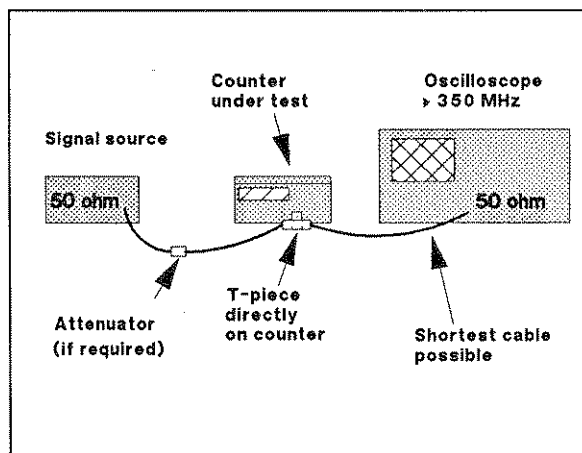

Figure 16. Connect the instruments like this.

Method 1

- Set the counter to maximum sensitivity.
- Adjust the amplitude of the signal-source to the minimum level accepted by the counter.
- Read the amplitude on the oscilloscope.
- Check that the reading is the same as, or less than, the sensitivity level in the counter specifications.

Method 2

- Adjust the amplitude of the signal-source until the oscilloscope indicates the sensitivity limit in the counter specifications.
- Check that the counter is operating correctly.

Low-impedance inputs ($50\ \Omega$)

If you have a calibrated signal-source

- Adjust the signal-source to the sensitivity limit of the counter.
- Connect it directly to the input of the counter.
- Check that the counter is operating correctly.

If you don't have a calibrated signal-source

Use either of the following methods

Method 1

- Connect the output of the signal-source directly to the input of the counter.
- Set the counter to maximum sensitivity (if adjustable).
- Adjust the amplitude of the signal-source to the minimum level accepted by the counter.
- Disconnect the cable from the counter and connect it to the oscilloscope.
- Read the amplitude on the oscilloscope.
- Check that the reading is the same as, or less than, the sensitivity level in the counter specifications.

Method 2

- Connect the signal-source to the oscilloscope.
- Adjust the output amplitude of the signal-source until the oscilloscope indicates the sensitivity limit in the counter specifications.
- Disconnect the cable from the oscilloscope and connect it to the counter.
- Set the counter to maximum sensitivity (if adjustable).
- Check that the counter is operating correctly.

These procedures ensure unambiguous measurements of the signal voltage at the input of the counter.

INDEX

- Abnormal bit
 See 'Status Byte' 41
- Accessories 61
- Address 35
- Address-selector
 where is it? 6
- Attenuator 26
- ATTx10 26
- Battery unit
 Installation 13
 Operation 30
 Preventive maintenance 30
 Specifications 60
 Storage 30
- Bus commands that gives an
 answer
 GPIB 45
- Bus Learn
 GPIB 45
- Caution statements 4
- Check-list
 GPIB program 36
- Checking
 GPIB-communication 35
- Colours on the front panel
 See 'Front panel logic' 17
- COM B via A 28
- Controller
 Connecting GPIB 35
- Controls,
 operation 18 - 29
- Cover removal 11
- Crystal oscillator
 Specifications 58
- Default settings
 See 'Counter settings after
 switching on' 17
 Specifications 58
- Delimiters
 See 'Separators' 36, 37
- Dimensions 57
- Display
 Specifications 58
 Time 58
- Display-hold
 Operating the button 24
 Specifications 58
- Earthing 10
- Environmental specification 57
- EOI mode
 See 'Output separator' 37
- Error codes 19, 31
- External-reference
 Connection 28
 Description 29
 Specifications 57
 Where is the input? 6
- Free-Run
 From GPIB 39
- Frequency A
 From GPIB 37
 Measurements 18
 Specifications 54
- Frequency B
 From GPIB 37
 Specifications 54
- Frequency C
 From GPIB 37
 Measurements 18
 Specifications 54
- Front panel
 Presentation 6
 Logic 17
- Function selection
 GPIB 37
 From front panel 18
- GET
 See 'Triggered' 39
- GPIB-interface
 Installation 12
 Operation 33
 Specifications 59
 Where is the connector? 6
- Grounding 10
- HF-input
 installation 11
 Specifications 57
- High-speed dump
 GPIB 43
- High-stability oscillator
 Installation 12
- HOLD
 display 24
- ID?
 GPIB 35
- Identity of counter 35
- IEC-625 bus
 See GPIB-bus 33
- IEEE-488 bus
 See GPIB-bus 33
- Inaccuracy
 Definition 56
- Index 65
- Input separator
 GPIB 36
- Input-A
 Operation 24
 Specifications 56
- Input-B
 Operation 24
 Specifications 56
- Input-C
 Operation 28
 Specifications 57
- Installation 9
- Installing options 11
- Local 24
- LSD displayed 55
- Measuring
 Frequency A 18
 Frequency C 18
 Period 18
 Ratio A/B 20
 Time interval A-B 20
 Time selection 22
 Total No. of pulses on A 20
 Voltage 20
 Rate 58
- Measuring-time
 From GPIB 38
 Operation 22
 Specifications 58
- MTCXO
 Calibration 30
 Installation 12
 Specifications 58
- Normal output format
 GPIB 42
- Operating instructions 15
- Operating the controls 18 - 29
- Options
 Available 6
 Installation 11
 Ordering information 61
- Oscillator replacement
 See MTCXO 12
- Output mode
 GPIB 42
- Output separator
 GPIB 37
- Period
 Measurements 18
 From GPIB 37
 Specifications 54
- PM 9604
 See 'GPIB-interface'
- PM 9605
 See 'Battery unit'
- PM 9606
 See 'Rack-mount kit'
- PM 9607
 See 'MTCXO'
- PM 9608 and PM 9608B
 See 'HF-input'
- PM 9609
 See 'Carrying case' 61
- PM 9615
 See 'HF-input'
- Power
 Requirements 57
 Where is the inlet socket? 6

Prescaler		Totalize A	
See HF-input	11	Description of function	21
Product Presentation	5	From GPIB	37
Programming Check-list	36	Selection	20
Rack-mount kit		Specifications.	55
Installation	13	Trigger level	
Specification	60	Operation, see 'set value'	
Ratio A/B		GPIB.	38
GPIB.	37	Specification	56
Measurements	20	Trigger slope	
Specifications.	54	From GPIB	38
Read level	28	Triggered mode	
Rear panel		From GPIB	39
presentation	6	Unpacking	10
Removing the cover	11	Using PM 2201	
Reset		GPIB-example	49
Description of function	25	Volt max/min	
Operating the button	24	GPIB.	37
Specifications.	58	Operation	20
Resolution		Voltage-range	
Definition	55	Where is the range selector?	6
Safety	3	Selecting	10
Selecting Function		Specifications.	57
From the front panel.	18	Warning statements	4
via GPIB	37	Weight	57
Sensitivity			
Operation, see 'Set value'			
GPIB.	38		
Specification	56		
Set value			
Description of function	27		
Operating the control	26		
Short output format			
GPIB	42		
Slope			
Operation	26		
GPIB	38		
Start/Stop Totalize			
Operation	24		
From GPIB	40		
Starting a new measurement			
Operation, see 'Reset'	24		
GPIB, see 'Bus Trigger'	40		
Status byte, GPIB	41		
Switching ON	17		
Symbol descriptions	4		
Talk-Only switch	35		
Test at power ON	17		
Time interval A/B			
GPIB	37		
Operation	20		
Specification.	54		
Time-base			
Also see MTCXO			
Specifications	58		
Time-out			
GPIB	41		

