

Programmable synthesizer /
function generator 0.1mHz – 20 MHz

PM 5192

9445 051 92001

Service manual

9499 455 00211

870801

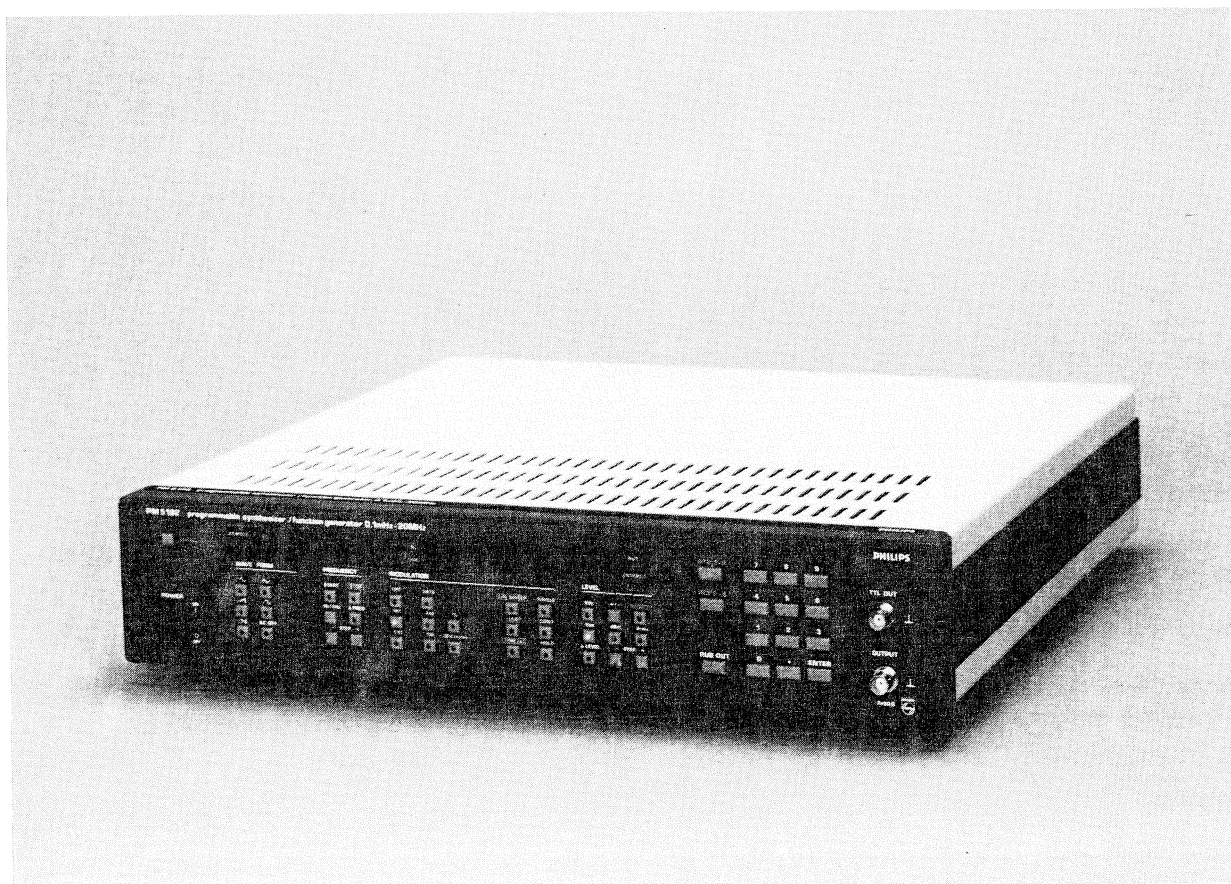

PHILIPS

Please note

In correspondence concerning this instrument, please quote the type number and serial number as given on the type plate.

Bitte beachten

Bei Schriftwechsel über dieses Gerät wird gebeten, die Typennummer und die Gerätenummer anzugeben. Diese befinden sich auf dem Typenschild an der Rückseite des Gerätes.

Noter s. v. p.

Dans votre correspondance et dans vos réclamations se rapportant à cet appareil, veuillez toujours indiquer le numéro de type et le numéro de série qui sont marqués sur la plaquette de caractéristiques.

Important

As the instrument is an electrical apparatus, it may be operated only by trained personnel. Maintenance and repairs may also be carried out only by qualified personnel.

Wichtig

Da das Gerät ein elektrisches Betriebsmittel ist, darf die Bedienung nur durch eingewiesenes Personal erfolgen. Wartung und Reparatur dürfen nur von geschultem, fach- und sachkundigem Personal durchgeführt werden.

Important

Comme l'instrument est un équipement électrique, le service doit être assuré par du personnel qualifié. De même, l'entretien et les réparations sont à confier aux personnes suffisamment qualifiées.

© Philips GmbH – Hamburg – Germany – 1987

Sie

All rights are strictly reserved.

Reproduction or divulgation in any form whatsoever is not permitted without written authority from the copyright owner.

Issued by Philips GmbH -Unternehmensbereich Elektronik für Wissenschaft und Industrie- Werk für Meßtechnik

Printed in Germany

CONTENTS

1.	SAFETY INSTRUCTIONS	1-1
1.1.	Safety precautions	1-1
1.2.	Caution and warning statements	1-1
1.3.	Symbols	1-1
1.4.	Impaired safety-protection	1-1
1.5.	General clauses	1-1
1.6.	Connections	1-2
2.	MAINS VOLTAGE SETTING AND FUSES	2-1
3.	OPERATING PRINCIPLE	3-1
3.1.	General operating principle	3-1
3.2.	Description of the blockdiagram	3-1
4.	PERFORMANCE CHECK	4-1
4.1.	General information	4-1
4.2.	Power-on selftest	4-1
4.3.	General functional test	4-2
5.	DIAGNOSTIC-PROGRAM PM 5192	5-1
6.	CIRCUIT DESCRIPTIONS	6-1
6.1.	Digital frequency synthesizer/U2	6-1
6.2.	PLL/U1	6-5
6.3.	Modulator/U1	6-9
6.4.	Pulse generator/U1	6-13
6.5.	Amplifier/U1	6-14
6.6.	CPU/U2	6-16
6.7.	Keyboard display unit/U3	6-19
7.	ACCESS TO PARTS	7-1
7.1.	Top and bottom covers (dismantling the instrument)	7-1
7.2.	Fuse, mains transformer	7-1
7.3.	Unit 1 and unit 2	7-1
7.4.	Front-panel edging	7-1
7.5.	Text plate	7-2
7.6.	Unit 3 (keyboard and display)	7-3
7.7.	Carrying handle	7-3
7.8.	Handle assembly for rack mounting	7-4
7.9.	View into the open instrument	7-4
8.	CHECKING AND ADJUSTING	8-1
8.1.	General Information	8-1
8.2.	Recommended test equipment	8-1
8.3.	Table of checks and adjustments	8-2
9.	SAFETY INSPECTION AND TESTS AFTER REPAIR AND MAINTENANCE IN THE PRIMARY CIRCUIT	9-1
9.1.	General directives	9-1
9.2.	Safety components	9-1
9.3.	Checking the protective earth connection	9-1
9.4.	Checking the insulation resistance	9-1
9.5.	Test after repair and maintenance	9-1

10.	SPARE PARTS	10-1
10.1.	General	10-1
10.2.	Static sensitive components	10-1
10.3.	Handling MOS devices	10-1
10.4.	Soldering techniques	10-1
10.5.	Parts list PM 5192	10-2
11.	FIGURES 28 – 44	
Fig. 28	Unit 2, adjusting elements	
Fig. 29	Unit 1, adjusting elements	
Fig. 30	Block diagram	
Fig. 31	Front view	
Fig. 32	Rear view	
Fig. 33	Overall circuit diagram	
Fig. 34	Unit 1, component lay-out	
Fig. 35	Power supply	
Fig. 36	Unit 1, pulse generator	
Fig. 37	Unit 1, PLL/VCO	
Fig. 38	Unit 1, output amplifier	
Fig. 39	Unit 1, modulator	
Fig. 40	Unit 2, component lay-out	
Fig. 41	Unit 2, CPU	
Fig. 42	Unit 3, (keyboard/display) component lay-out	
Fig. 43	Unit 3, keyboard display	
Fig. 44	Unit 2, digital frequency synthesis (DFS)	
12.	CODING SYSTEM OF FAILURE REPORTING FOR QUALITY	
13.	ADDRESSES FOR SALES AND SERVICE	

1. SAFETY INSTRUCTIONS

WARNING:

These servicing instructions are for use by qualified personnel only. To reduce the risk of electric shock, do not perform any servicing other than that specified in the Operating Instructions unless you are fully qualified to do so.

Read these pages carefully before installation and use of the instrument.

The following clauses contain information, cautions and warnings which must be followed to ensure safe operation and to retain the instrument in a safe condition.

Adjustment, maintenance and repair to the instrument shall be carried out only by qualified personnel.

1.1. SAFETY PRECAUTIONS

For the correct and safe use of this instrument it is essential that both operating and servicing personnel follow generally-accepted safety procedures in addition to the safety precautions specified in this manual. Specific warning and caution statements, where they apply, will be found throughout the manual. Where necessary, the warning and caution statements and/or symbols are marked on the apparatus.

1.2. CAUTION AND WARNING STATEMENTS

CAUTION:

Is used to indicate correct operating or maintenance procedures in order to prevent damage to or destruction of the equipment or other property.

WARNING:

Calls attention to a potential danger that requires correct procedures or practices in order to prevent personal injury.

1.3. SYMBOLS



Protective earth
(grounding) terminal

(black symbol on yellow background or impressed,
e. g. at the mains connector at the rear)

1.4. IMPAIRED SAFETY-PROTECTION

Whenever it is likely that safety-protection has been impaired, the instrument must be made inoperative and be secured against any unintended operation. The matter should then be referred to qualified technicians.

Safety protection is likely to be impaired if, for example, the instrument fails to perform the intended measurements or shows visible damage.

1.5. GENERAL CLAUSES

WARNING:

The opening of covers or removal of parts, except those to which access can be gained by hand, is likely to expose live parts and accessible terminals which can be dangerous to live.

The instrument shall be disconnected from all voltage sources before it is opened.

Bear in mind that capacitors inside the instrument can hold their charge even if the instrument has been separated from all voltage sources.

WARNING:

Any interruption of the protective earth conductor inside or outside the instrument, or disconnection of the protective earth terminal, is likely to make the instrument dangerous. Intentional interruption is prohibited.

Components which are important for the safety of the instrument may only be renewed by components obtained through your local Philips organisation (see also chapter 9.).

After repair and maintenance in the primary circuit, safety inspection and tests, as mentioned in chapter 9 have to be performed.

1.6. CONNECTIONS

The circuit earth potential is applied to the external contacts of the BNC sockets and is connected to the cabinet by means of parallel-connected capacitors. By this means hum loops are avoided and a clear HF earthing is obtained.

If the circuit earth potential in a measurement set-up is different from the protective earth potential, it must be noticed,

- that the BNC sockets can be touched and that it must not be live, see the safety regulations on the subject (VDE 0411),
- that all sockets marked with the sign \perp are internally interconnected.

2. MAINS VOLTAGE SETTING AND FUSES

The safety instructions in previous chapters must be followed.

- PM 5192: On delivery from the factory the instrument is set to 220 V – AC.
- PM 5192 M (USA): On delivery from the factory the instrument is set to 120 V – AC up to ser. no. LO-01690 or to 120 V – AC from ser. no. LO-02691 onwards.

If the instrument is to be used on a different supply voltage the wiring must be altered; the main fuse should be replaced dependent on the mains voltage. The wiring for the fan must not be altered.

Proceed as follows:

- Loosen 2 cross-slotted screws at the rear side of the instrument (see also chapter 7.1.).
- Remove the top cover.
- Remove the isolating cover of the topside of the mains transformer, remove cable binder before.
- Alter the wiring of the mains transformer according to the connection diagram.
- Refit the isolating cover.
- If necessary, insert the advised fuse into the fuse holder instead of the fuse built-in. In this case change current label of the fuse holder.
- Change the mains voltage label at the rear of the instrument in accordance with the mains voltage selected.
The labels for the mains voltage, current and the fuse are enclosed in a plastic bag.
- Close the instrument.

Connection diagram

Up to series number LO-01690

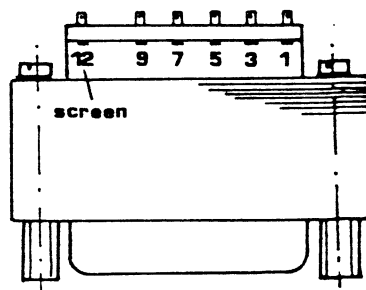
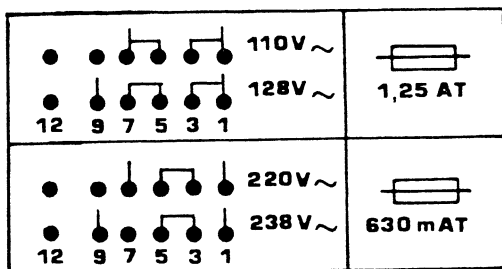

From series number LO-02691 onwards:

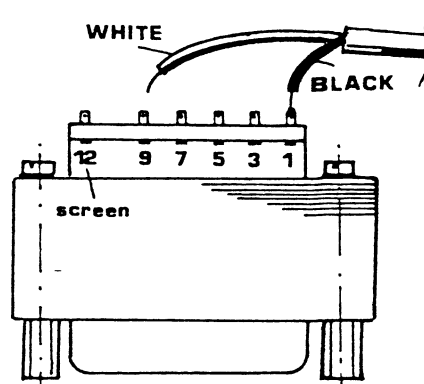
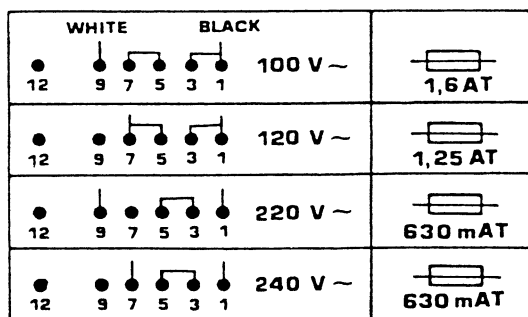

3. OPERATING PRINCIPLE, Fig. 30 (Block diagram)

3.1. GENERAL OPERATING PRINCIPLE

The basic functional units, performing the generation, processing and conditioning of the generator output signals, are named

– DFS, Digital Frequency Synthesizer,	on unit 2
– PLL, Phase Locked Loop,	on unit 1
– MODULATOR	on unit 1
– PULSE GENERATOR	on unit 1
– AMPLIFIER	on unit 1

These functional units are under control of the CPU (Central Processing Unit), consisting of a micro-processor and its peripheral components on unit 2. Primary control data for the CPU is derived from the front-end KEYBOARD & DISPLAY on unit 3 or from an external controller via the IEEE/IEC bus interface. The output-signal parameters are displayed numerically on a 7-segment-LED display. Key LEDs are provided for operating mode indication. Subsequently a brief description of the over-all block diagram (fig. 2) of the generator is given.

3.2. DESCRIPTION OF THE BLOCK DIAGRAM

DFS

In the frequency range up to 2147 kHz the primary signals – sine, triangular, positive and negative sawtooth waves – are generated by direct digital signal synthesis.

Binary samples of the wave are created in the SIGNAL SYNTHESIZER section and converted to analogue voltages by a fast DAC at the clock rate f_c . The output frequency f_o is directly related to f_c , according to

$$f_o = 0.1 \cdot N \cdot 2^{-33} \cdot f_c = N \cdot 10^{-4} \text{ Hz}$$

where N is the decimal equivalent of the binary frequency word, routed to the SIGNAL SYNTHESIZER from the CPU via U2-CONTROL BUS. f_c is generated by an x-tal oscillator, the 8.59 MHz CLOCK. The AUTOMATIC SWITCH alternatively routes the external clock frequency to the SIGNAL SYNTHESIZER, if this is applied to the CLOCK INPUT. The DAC output signal is smoothed by the 3 MHz LPF, an anti-aliasing low-pass filter.

PLL

In the frequency range above 2147 kHz the primary sine wave is generated in the PLL. The PLL consists of a broad-band VCO, Voltage-Controlled Oscillator, – with a triangular-wave output signal fed to the SINE SHAPER – the FREQUENCY DIVIDER, the PHASE DETECTOR and the LOOP FILTER. By the PLL the PLL REF frequency – generated in the DFS – is multiplied by a factor of 4096 in FM mode and 16 otherwise. For fast phase-locking response the VCO is preset roughly by the DAC to the programmed frequency.

MODULATOR

By the VOLTAGE CONDITIONER the DFS sawtooth wave is halved in amplitude and shifted in dc, resulting in unipolar signals. The sine wave and the triangular wave are routed without change through the VOLTAGE CONDITIONER to diode SWITCH 1. In the frequency range above 2147 kHz the RF SINE wave is routed from the PLL to DIODE SWITCH 2 and to the AMPLITUDE MODULATOR or directly to the AMPLIFIER. Both diode switches are served by the SWITCH CONTROL, which evaluates the accurate control signal from the 2 MHz SWITCH control signal from the CPU and the GATE signal from the SWITCHING CIRCUITRY in the GATE mode of the generator.

In internal GATE, AM or FM mode the modulating signal is derived from the MODULATION OSCILLATOR output. The output sine wave is scaled in amplitude by the AMPLITUDE CONTROLLER to give the accurate AM or FM modulation depth. The modulating sine wave is fed to the AMPLITUDE MODULATOR in AM mode or to the PLL in FM mode through the SWITCHING CIRCUITRY. Alternatively – in the external modulation modes – the modulating signal is supplied from the generator MODULATION INPUT.

PULSE GENERATOR

The PULSE GENERATOR basically represents an electronical switching circuitry, creating a TTL signal and a square wave, each signal with a 50 % duty cycle. The instants of the positive and negative edges of these signals are determined by the zero-crossings of the reference input signal. In the frequency range up to 2147 kHz the DFS signal, e. g. a sine wave, fed to the ZERO CROSSING DETECTOR serves as reference. Above 2147 kHz the TTL output signal of the PLL, named RF TTL, directly determines the switching points.

By the CONTROL CIRCUITRY either the TTL output of the ZERO CROSSING DETECTOR or the RF TTL are routed to the switching output of the signal conditioners. The TTL OUTPUT STAGE and the SQUARE WAVE CONDITIONER are creating the TTL output voltage of the generator and the primary square wave with accurate amplitude and waveform.

AMPLIFIER

The vernier setting of the generator output amplitude is performed by the AMPLITUDE CONTROLLER. After amplification by the POWER AMPLIFIER the signal either directly or after 20 dB respectively 40 dB attenuation by the STEP ATTENUATOR is routed to the OUTPUT socket. The DC GENERATOR adds the programmed dc voltage.

CPU

An 8-bit microprocessor (8031) and a 10 MHz clock are the constituents of the PROCESSOR & CLOCK. The PROGRAM MEMORY is a 16 Kbyte EPROM. In an external data memory, the 256 byte RAM, the 10 storage register contents of the generator are stored. By the CONTROL BUS DRIVER the required load capability of the U1- and U2 CONTROL BUS serial data line (SDA), and the clock line (SCL), is achieved. The device selecting strobe signals STR1 ... 15 – used for CPU components and latching-data – shift registers in the various functional units controlled by the CPU – are derived from 4 ports of the PROCESSOR by the STROBE DECODER.

By the DIRECT PORT LATCH two output port signals – 2 MHz SWITCH and PLL CNTL – are derived from three address/data bus lines of the CPU. The SWEEP VOLTAGE DAC is generating a voltage ramp during a frequency sweep. The PEN LIFT SWITCH serves for lifting the writing pen of an x-y plotter during frequency sweep fly-backs.

The IEEE/IEC bus interface of the generator consists of the IEC BUS CONTROLLER, the DEVICE ADDRESS LATCH & SHIFT REGISTER and the 3-STATE GATE & LATCH.

4. PERFORMANCE CHECK

4.1. GENERAL INFORMATION

WARNING:

Before switching on, ensure that the instrument has been installed in accordance with the instructions outlined in Section 2 of the Operating Manual: Installation instructions.

This procedure is intended to:

- check the instrument
- be used for incoming inspection to determine the acceptability of newly-purchased instruments and/or recently-recalibrated instruments.

ATTENTION:

The procedure does not check every detail of the instrument's calibration; rather, it is concerned primarily with those parts of the instrument which are essential to measurement accuracy and correct operation. Removing the instrument covers is not necessary to perform this procedure. All checks are made from the front panel.

If this test is started within a short period after switching on, bear in mind that steps may be out of specification, due to insufficient warming-up time. To avoid this situation, allow the specified warming-up time of 30 min.

4.2. POWER-ON SELFTEST

Immediately after power on a selftest routine is started with which PROM and RAM are tested. If an error is detected one of the following error messages appears:

ERR 1	PROM	checksum error
ERR 2	RAM	(processor) checksum error
ERR 3	RAM	checksum error; operation possible but memory contents is destroyed.

In case of no error in PROMs/RAMs all LEDs and all segments of the displays are then switched on for appr. 3s after the software version has been indicated in the 'LEVEL'-sector of the display. The instrument must then be in the on-state which is indicated by a zero in each of the display sections and the LEDs in the keys SINE, START, OFF and Vpp switched on.

4.3. GENERAL FUNCTIONAL TEST

The function of the synthesizer can now be checked with the help of the following examples:

amplitude = 5 Vpp; offset = 0 Vdc

terminate the output with 50 Ω and connect an oscilloscope.

Wave form	start frequency	stop	modulation			defective unit in case of faulty function
			-mode	-frequency	-depth, -deviation sweep time,	
1) triangle	50 kHz	—	—	—	—	DFS
2) sine	500 kHz	—	AM	1 kHz	50 % depth	modulator
3) square	5 MHz	—	FM	1 kHz	100 kHz dev.	modulator, PLL pulse generator
4) pos. sawtooth	1 MHz	10 MHz	Sweep Lin.	—	5 sec. sweep time	CPU, DFS

If one of the functions doesn't work, the diagnostic program can be a help to distinguish whether the defect is in the unit in question or in the CPU with its C-bus drivers/decoders. By selecting TEST 4 (strobe test) it is possible to check the data communication lines and the decoders of the subunits.

In case that all functions are o. k. this test must be continued by checking the output signals:

TTL OUT: This output shows always a square wave voltage with TTL-level and signal-frequency.

INT CLOCK: This output contains the clock-signal of the internal digital frequency synthesizer with TTL-level and a frequency of 8.58993 MHz.

MODULATION: This output shows a sinewave signal with an amplitude of max. 1 Vrms depending on modulation depth/deviation and modulation frequency.

PEN LIFT: In the continuous sweep mode this output shows a sequence of pulses. The frequency corresponds to the sweep repetition rate, amplitude is 20 Vpp.

SWEEP: During continuous sweep operation this output shows a sawtooth voltage with an amplitude of 10 Vpp.

5. DIAGNOSTIC-PROGRAM PM 5192

This test program contains 5 submodules:

- TEST 1: Display and LED test
- TEST 2: Keyboard test
- TEST 3: Storage register test
- TEST 4: Strobe test (test of the internal interfaces)
- TEST 5: Test for the IEEE/IEC-BUS interface

To activate this test program, press the key MODULATION OFF while power is switched on and keep it pressed for about 3 seconds.

The return to the main operating mode is only possible by switching power OFF and ON again.

When the test program is activated, the display shows "TEST x" where 'x' is a number from 1 to 5. This number changes continuously and slowly, and by pressing the key MODULATION OFF at the right moment, the respective test-submodule will be started.

To leave the test submodules, press the key MODULATION OFF for about 2 seconds.

TEST 1 : Display and LED test

Step 1: 7-segment-display

All display segments and LEDs are switched on for about 2 seconds. After this the program starts to switch on one segment after the other for four display positions simultaneously. Finally, the decimal points of these four positions remain lit and the program starts to do the same with the next four display positions. After the last four digits were tested, the program switches on all segments and LEDs and remain in this state until the key MODULATION OFF was pressed once again.

Step 2: LEDs

All LEDs will be switched on sequentially, one after the other, for approx. 0.5 seconds beginning with the uppermost left one (inside the key sine wave). When the last LED was switched on the indication "End" appears at the display until the key MODULATION OFF was pressed. Then the program returns to the test-menu.

TEST 2: Keyboard test

The display shows the indication: 1 - 01 - - - -

Now you must press the first key of the first row: 1 - 01 - - - -
(row 1) - (column 1)

Keyboard

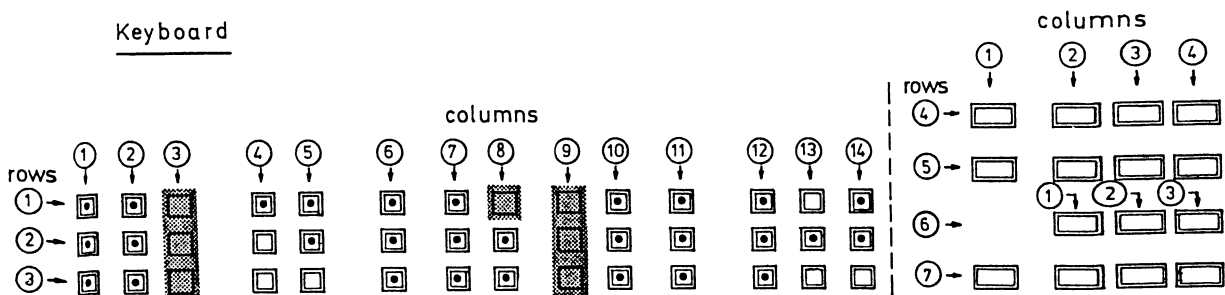

When the right key was pressed, the display shows

1 - Ø1 1 1 1 1

for about 1 second and changes then to

1 - Ø2 - - - -

as a request to press the second key in the first row. In case of a failure, the display would show

Err 1 - Ø1 x - xx

where x - xx indicates the wrong code (row and column). This error indication will only be reset by pressing the requested key - in case of a hardware failure at the keyboard unit it would not be possible to get the right code and thus to reset the error message.

When the last key was pressed, the keyboard test is finished and the display indicates "End". To leave this diagnostic submodule and to get back to the test menu, the key MODULATION OFF must be pressed.

TEST 3 : Storage register test

Attention:

This memory test damages the register contents. When the instrument is switched on after the storage register test was executed, the display indicates "Err 3" which means that there are now no parameters in the storage register - the complete contents (parameters) are destroyed.

The display indicates

MEMO 1 -

and the program starts to write a test pattern into each location of memory chip 1, reads it again, and checks this value for correctness. When no failure was detected, the same will be done with a second pattern. In case that there is no failure, the display shows

MEMO 1 - 1

and in case of a failure

MEMO 1 - Ø

Now the program waits until the key MODULATION OFF is pressed and starts then to check the memory chip 2 in the same way as described above. When this is terminated successfully, the display indicates

MEMO 2 - 1

or in case of a failure

MEMO 2 - Ø

With MODULATION OFF the program returns to the test menu.

TEST 4 : Strobe test

The display indicates

STRO x

where x is a number from 6 to 15. This number changes continuously and slowly. By pressing the key "MODULATION OFF" at the right moment the required strobe line will be selected. The display shows then e.g.:

STRO 08 – 1

which means that the output lines of the shift registers controlled by strobe line 8 show a specific bit-pattern. If MODULATION OFF was pressed once for a short moment all output lines of the shift registers change their state. Now the display shows:

STRO 08 – 0

Each time the MODULATION OFF-key is pressed for a short moment, the states of these output lines will be inverted. If MODULATION OFF is pressed for longer than about 1 second, this subprogram will be left and the display shows again:

STRO x

If the key MODULATION OFF is pressed again for longer than about 1 second, the program will return to the test menu.

This strobe test serves fault finding in the internal C-bus system. Measuring points, positions of ICs and measuring values are given in the following tables.

By strobe lines controlled ICs show the following bit patterns during STROBE-test:

Bit pattern ICs HEF 4094								
Pin no.	4	5	6	7	14	13	12	11
Strobe 'x' – 0	0	1	0	1	0	1	0	1
Strobe 'x' – 1	1	0	1	0	1	0	1	0

Association of these ICs:

Strobe line	Controlled ICs (Pos. no.)	Location
Strobe 7	307, 308, 309, 310, 311	"DFS", unit 2
Strobe 8	302, 306, 312	"Output Amplifier", unit 1
Strobe 9	302, 313, 316	"Modulator", unit 1
Strobe 11	301	"PLL", unit 1
Strobe 13	321	"SWEEP" CPU, unit 2
Strobe 15	311	"IEC-bus, function and address" CPU, unit 2

Bit pattern IC N74LS175		
Pin no.	2	7
Strobe 'x' – 0	1	0
Strobe 'x' – 1	0	1

Association of this IC

Strobe line	Controlled IC (Pos. no.)	Location
Strobe 12	313	"Direct port" CPU, unit 2

Bit pattern IC HEF 40373								
Pin no.	2	5	6	9	12	15	16	19
Strobe 'x' – 0	0	1	0	1	0	1	0	1
Strobe 'x' – 1	1	0	1	0	1	0	1	0

Association of this IC

Strobe line	Controlled IC (Pos. no.)	Location
Strobe 14	308	"IEC-bus out" CPU, unit 2

Strobe lines 6 and 10 are not used and have no control function.

TEST 5: IEC-bus test

The display shows the indication

IEC BUS

Each character sent from the controller via the IEC (IEEE)-bus will be decoded and displayed with its hexadecimal code, e. g.

ASCII 'A' indication 41 H
 ASCII '3' indication 33 H
 etc.

The device address of the PM 5192 is fixed to 20.

With the key MODULATION OFF the program returns to the test menu.

6. CIRCUIT DESCRIPTIONS

6.1. DIGITAL FREQUENCY SYNTHESIZER/U2

Signal Synthesizer

The primary signal of PM 5192 in the frequency range up to 2.147 MHz is generated in the digital frequency synthesizer (DFS). At the output of the digital section of the DFS the signal is presented as a sequence of 9 bit binary numbers. The digital samples of the signal are then converted to analogue voltages by means of a fast DAC.

The frequency of the DFS is determined by a 40 bit frequency word which is sent to the shift registers 307 – 311 from the CPU. The bit parallel shift register outputs are connected with the phase accumulator inputs. The phase accumulator is clocked by 8.5899 MHz from the clock generator. With each clock pulse the 9 bit-phase-accumulator output is incremented by the value of the frequency word. The resulting sequence of binary numbers represents a periodic sawtooth wave. By intermittent one's complementing (complementer 1) the signal is converted to a triangular wave. The samples of this signal are used as addresses for reading out a sine table ROM. The output is representing sine wave values for the first quarter period (4). By intermittent one's complementing in complementer 2 this signal is converted to a full sine wave (7).

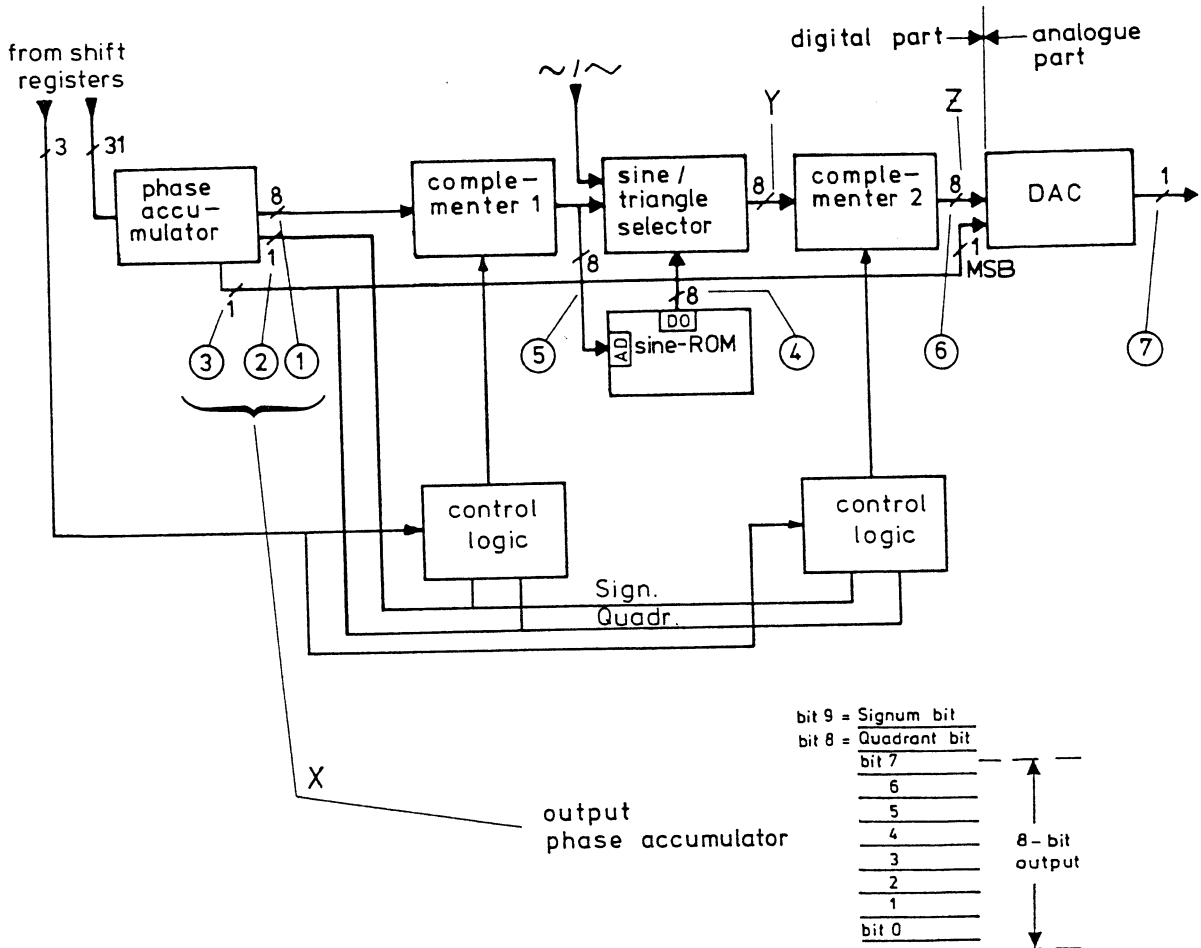

The phase accumulator is functionally divided into two parts. The upper part consists of the adders 312 – 319 and the D-registers 322 – 326 for the frequency range 1 MHz – 2.147 MHz. Frequency values for this range are sent in the 1 – 2 – 4 – 8 code. The lower part consists of the adders 320 and 321, the NOR gate 305 and the D-register 326 and covers the range 0.1 – 1 MHz. For this range the frequency values are applied in the Excess – 3 code.

The upper part of the phase accumulator generates a sequence of 33 bit binary numbers from 0 to $2^{33} - 1$. With each clock pulse the output is incremented by the value of the input frequency word. When reaching the upper limit the accumulator output is reset and starts again with incrementing. This results in a cyclic sequence of binary numbers which have a sawtooth wave form character. The frequency is $f_g = 1/T = \delta \cdot f_c \cdot 2^{-L}$ where δ is the value of the frequency word, f_c the clock frequency (8.5899 MHz) and L the length of the phase accumulator (33 bit).

The upper 10 bit of the phase accumulator are used for subsequent signal processing. The samples of the lower 8 bit of them represent a sawtooth wave with the period $T/4$ (1A). The upper two of the 10 bit accumulator output (signum bit (2), quadrant bit (3)) determine the quadrant in which the vector of the DFS output signal (7) is actually located. In complementer 1 (exclusiv – or gates 331, 332) the 8 bit output is inverted during the second and fourth quarter period. The resulting signal (5) is fed to the sine/triangle selector (ICs 336, 337) and parallel to the address lines of the sine-ROM in which the sine wave values for the first quarter period ($0 - \pi/2$) are deposited.

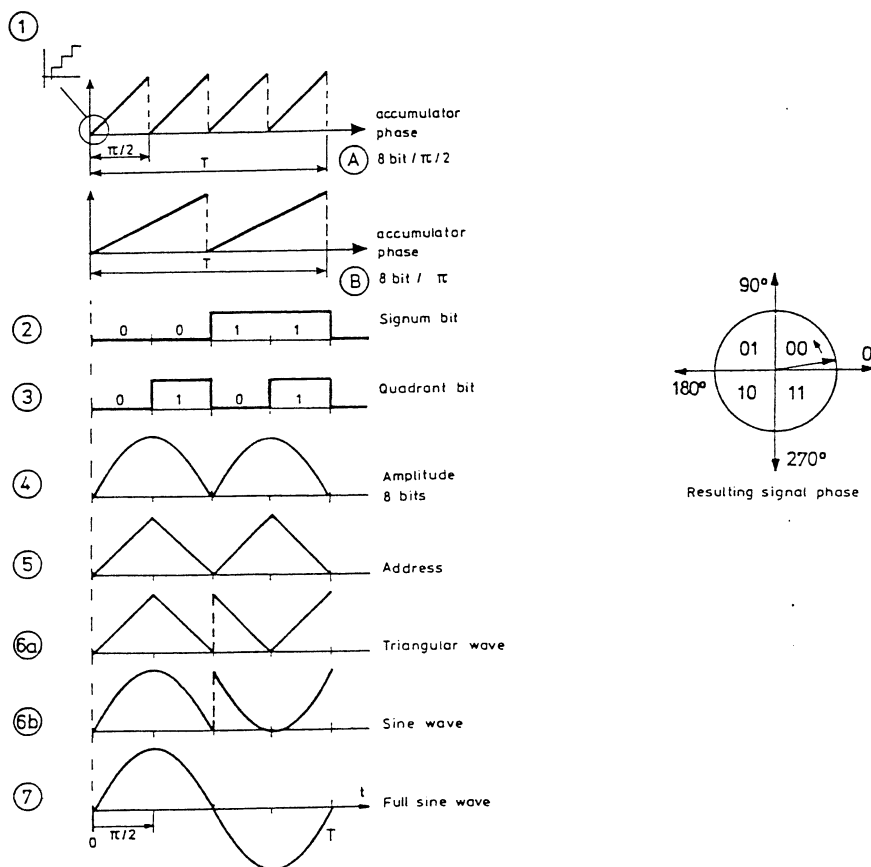

For generating the wave form triangle the output of complementer 1 is fed directly to the sine/triangle selector by-passing the sine ROM. Thus the sawtooth signal (5) applied to complementer 2 results in the wave form (6A).

For sine wave the output data of the sine ROM (4) is picked up by the sine/triangle selector and routed to complementer 2 resulting in wave form (6b). By adding the inverted signum bit (2) as the 9th bit, it results in wave form 7.

When generating positive or negative sawtooths the value of the binary frequency word at the phase accumulator input is halved — thus the sawtooth period at the phase accumulator output is doubled. For positive ramps control signal "a" is low. Therefore bit 0 – 7 are routed through complementer 1 without inversion to buffer 333 and 334. After passing sine triangle selector 336/337, the buffer 338/339 and complementer 2 without inversion ($b = 0$) the signal is latched to the output by the D – FFs 342/343. The ninth bit at output 2/342 is directly derived from bit 8 of the phase accumulator through MUX 347 and the buffers 333 and 338 (= signal c).

For negative going ramps one difference is that control signal "a" is high. Therefore the signal (bit 0 – 7) is inverted by complementer 1. The second difference is that the ninth output bit (= c) is inverted by exclusive – or gate 327 (pins 8, 9, 10) at input pin 2 of MUX 347.

With 'low' at the reset input the phase accumulator output can be set to zero. After reset is switched back to 'high', the signal generation is started and performed in the way as described before. The starting conditions are shown in the picture below.

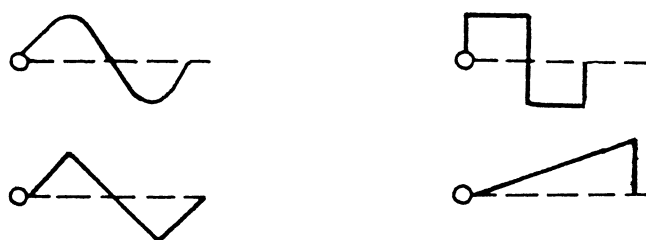

DAC

The binary signal coming from complementer 2 via buffers 342, 343 is converted to an analog voltage in the DAC.

At the DAC inputs the drivers 344, 345 are located which are controlling the current switching differential transistor stages 427 – 428, 424 – 425, . . . The DC-currents (each 5.85 mA = I_0) are generated by individual circuitries. The MSB (bit 8) – current source for instance includes transistor 427 and one OP of IC 346. The bit 7 – current source includes transistor 424 and the other OP of IC 346. The remaining current sources use also this second OP of IC 346. The individual currents – if switched on – are routed to the corresponding nodes N0 – N8 of the R – 2 R ladder shown below. The input impedance of each node is $2 R/3$, where R is 619 ohm ($2 R/3 = 412, 67$ ohm). Therefore each current – if switched on – is building up the same voltage at the related node ($I_0 * 2 R/3 = 2,41$ V). The transformation to the output depends on the node position in the ladder. Generally from node n to node n+1 the voltage is divided by two. Thus for instance the bit 3 – node N3 voltage is transformed to the output node N8 by the factor $2^{-(8-3)} = 1/32$. The output voltage of the ladder at node N8 is filtered by the anti alias low pass filter 803, 804, 559 – 562. By this filter with a passband of about 3 MHz especially the spectral contents at both sides of the clock frequency (8.5899 MHz) are suppressed. The output signal is buffered with the transistors 430, 431.

For deglitching purposes of the DAC the current switching point of bit 8 can slightly be shifted with the trimpot 689 versus the current switching points of bits 0 – 7. The latter switching points are set with trimpot 676. By iterative calibration procedure with these both trimpots the sine wave distortion is minimized.

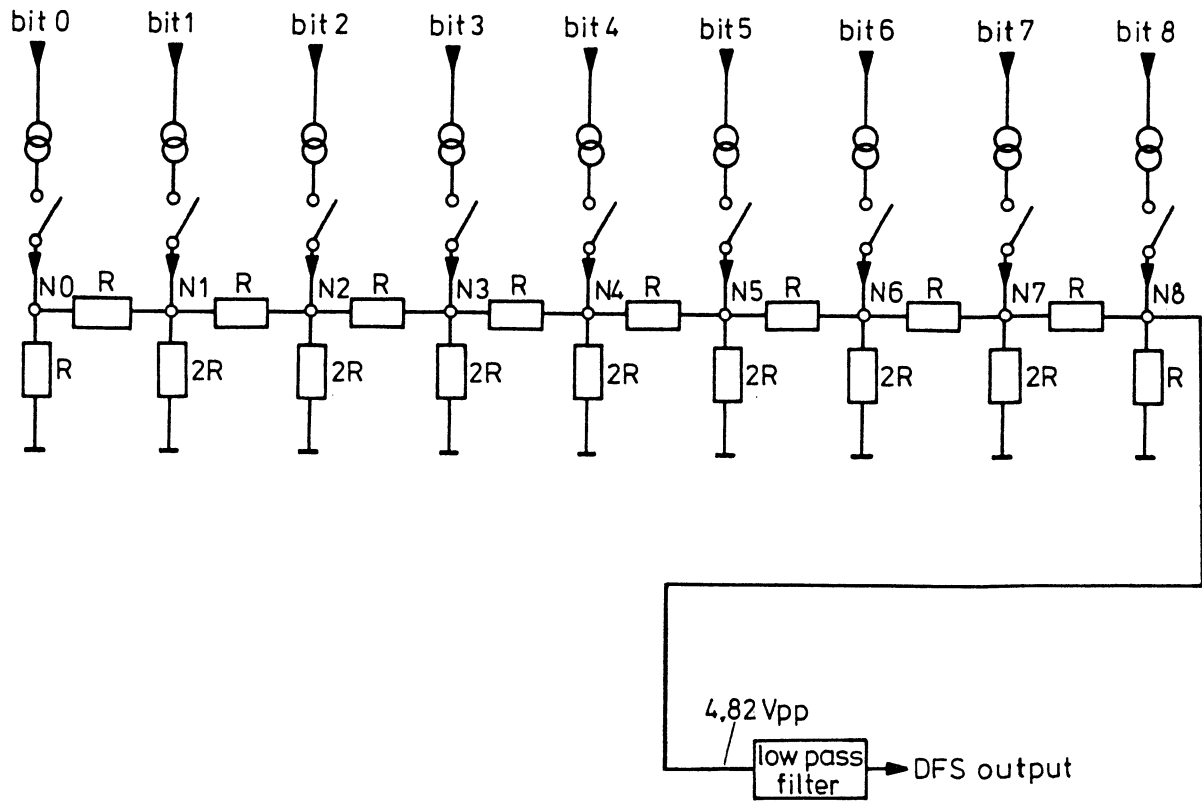

6.2. PLL / U1

In the frequency range above 2.147 MHz the primary signal is generated in the PLL. The PLL consists of a wide-band VCO, frequency divider, phase detector with loop filter and sine shaper.

DAC

Frequency coarse adjustment in the range above 2.147 MHz is achieved with the DAC which gets the information from the CPU via the C-bus, fine adjustment takes place via the PLL-loop by comparing the reference signal from the DFS with the VCO output divided by either 16 (= FM off) or 4096 (= FM on).

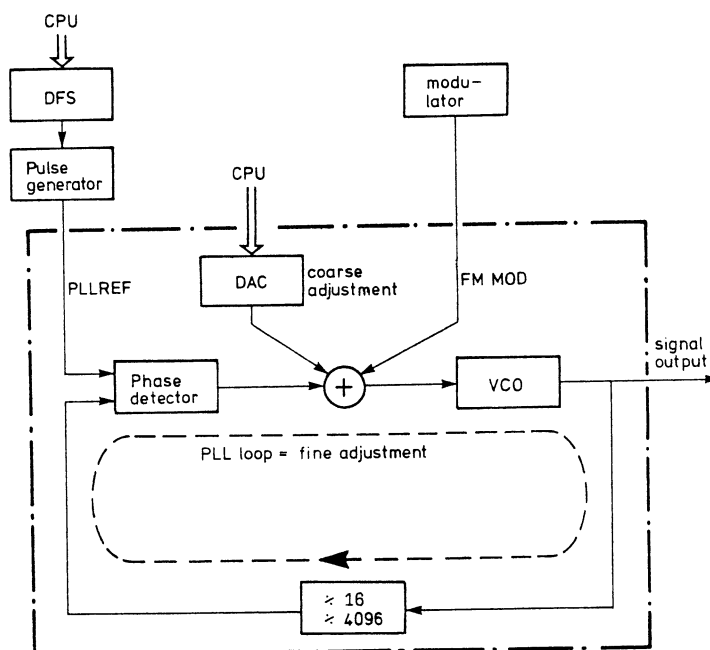

Phase Detector

The phase detector IC 309 compares the signals PLL REF and VCO output and generates a DC-signal which value depends on the phase difference between them.

The integration circuit following the phase detector consists of the integrated circuit 312, the 10 k Ω resistor 619 and the capacitors 516, 521 and 522. The purpose of the integrator is to filter spikes and short deviations in order to prevent disturbances of the PLL control loop. Time constant for FM off mode is 47 μ s (619, 516), with FM on it is 0.5 s (619, 521, 522). Switching FM on and off is achieved with control signal PLL CNTL and switch 313/1, 2, 15. With FM off the capacitors 521, 522 are continuously charged with OP-amp 311 according to the level at input 3 of the integrator. This effects a short lock-in time when FM is switched on, because the capacitors 521, 522 are always charged to the level according to the momentary frequency. The output of the integrator is passed via solder switch S6 and resistor 608 to the current summing point of the VCO.

The DAC for frequency coarse adjustment consists of the shift register IC 301 and the digital-analog converting circuit IC 302. The serial information from the CPU is received from the shift register, formed to a parallel information and fed to the parallel inputs of IC 302. The output of this circuit is buffered with OP-amp 303 and then passed via resistor 607 to the current summing point.

The last signal which is fed to the current summing point is generated in the modulator and passed via resistor 606. This FM MOD signal effects an amplitude modulation of the integrator — and DAC output signals at the current summing point, whereby the influences of these three signals in the summing point are weighted by the different values of the resistors 606, 607, 608. Lower resistance values effect a higher current going into the summing point thus giving a higher influence for the VCO. The highest current is delivered from the DAC via 607 (= 10K) followed by the phase detector output via 608 (= 75K) and the modulation signal FM MOD via 606 (= 365K).

VCO

The VCO consists of the input buffer 304, a current mirror with two current sources 306, 307, 351, 353, 354 and 356 an amplifier 361, 362, 363, 380 and a comparator 364, 366, 367 and 368.

The two current sources generate the currents 'I' and '2I', whereby the value of 'I' depends on the current in the summing point, the relation between the two currents is exactly 1 : 2. The current '2I' is going via transistor 356 to the transistors 357, 358 which are controlled from the comparator output. During the rising ramp (a) transistor 358 is open and feeds the current '2I' to the capacitors and to the transistor 359 which draws the current 'I' from this point, thus the two capacitors 526, 527 are charged with the current 'I'. During the falling ramp (b) transistor 357 is open and leads the current of '2I' to ground. Because the second current source draws the current 'I' continuously from the two capacitors 526 and 527, they are now discharged until the negative threshold is reached.

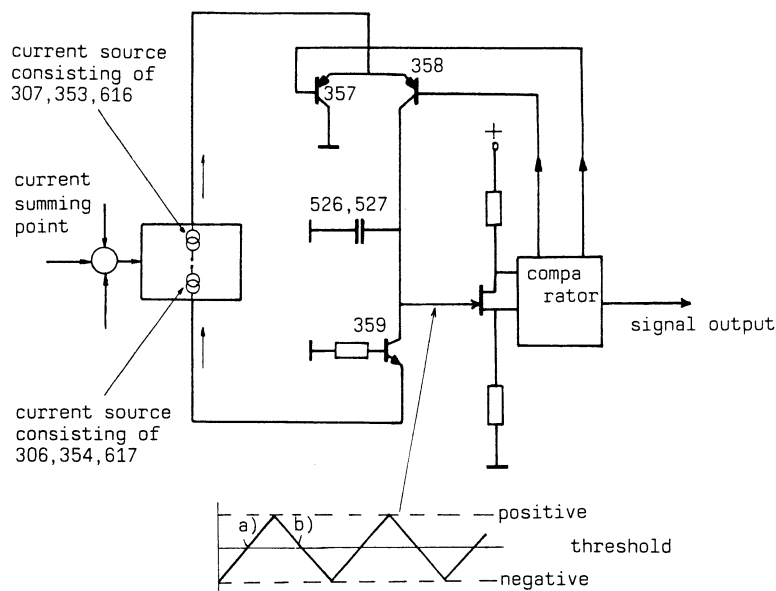

The stage following the triangular wave generator is the sense amplifier consisting of the transistors 361, 362, 363 and 380. This amplifier has a very high input impedance ($> 1 \text{ G}\Omega$), a total gain of 1 and supplies the inputs of comparator and sine shaper. The signals at these inputs have precisely the same phase as the signal at the capacitors 526, 527 and an amplitude of $2 V_{pp}$.

The comparator consists of the differential stage 364, 366 and the TTL switching circuit 367, 368. The two signals to be compared are fed to the bases of the transistors 364 and 366. The collectors of these transistors are controlling the bases of the transistors 367 and 368 thus generating a square wave signal which is connected to the base of transistor 366 via resistor 655. This effects the comparing of the positive ramp of the triangular wave with the positive half cycle of the square wave and of the negative ramp with the negative half cycle.

When the positive ramp of the triangular wave at the base of transistor 364 reaches the upper threshold determined by the level of the square wave at the base of transistor 366, the comparator switches and with this the collector of transistor 364 becomes more negative. This effects the switching of transistor 357 to the conducting state. Thus the current '2I' is drawn to ground, the capacitors 526 and 527 are discharged with the current 'I' and the triangular signal turns over to the negative ramp.

The RF TTL output is supplied from the TTL switching circuit in the VCO (367, 368) via decoupling transistor 379. This signal is then formed in the signal conditioner 369, 371 and fed to the output via the two buffers 314/1, 2, 3 and 314/11, 12, 13.

Frequency divider

The frequency divider of the PLL is also supplied from the TTL-output of the VCO (IC 314/3). This circuit serves the purpose to divide the VCO output frequency by the factor 16 for FM off and 4096 for FM on. Dividing takes place in four steps with the two dividing circuits 316 and 317, the divided value is available at pin 6 of IC 318 (a) and fed to input 1 of phase detector IC 309. Switching over from dividing factor 16 to 4096 is achieved via the gates 318/1, 2, 3 and 318/8, 9, 10 with the signal PLL CNTL (b) which is 'low' for FM on and 'high' for FM off.

Sine shaper

With the sine shaper -consisting of the transistor array 320 and the transistors 372, 373 the triangular wave from the VCO is formed to a sine wave and fed to the output RF-SINE via the sine wave amplifier (transistors 374 – 378).

The triangular wave is attenuated with the resistors 696 and 697 to 0.4 V_{pp} at the base of transistor 320/9, 10, 11. The base of the second transistor of this differential stage (320/6, 7, 8) is fixed to a constant level which is defined with potmeter 709 and resistors 707, 708. Because the operating point for this stage is adjusted such that the stage is overdriven with the tops of the triangular wave, the collectors (pins 11, 8) show a sine wave signal (see picture).

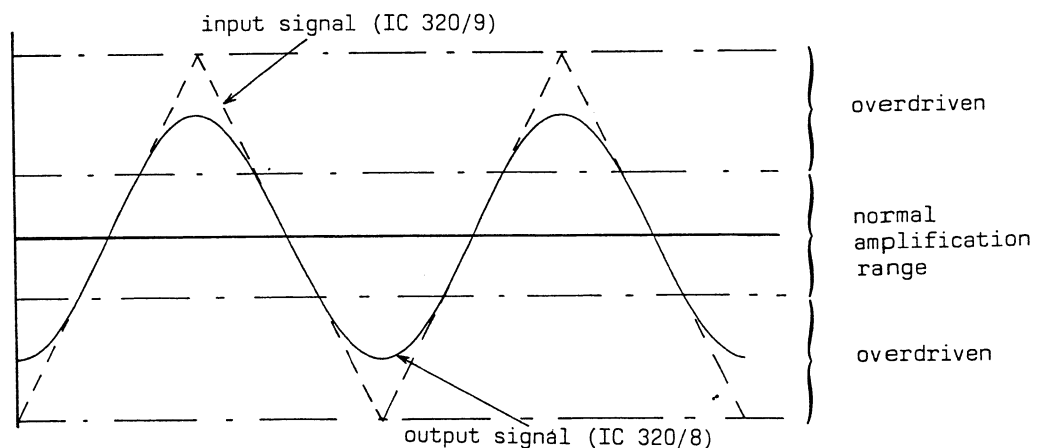

This principle of forming the triangular wave to a sine wave requires a stable and exactly defined operating point. Temperature drifts in the crystal of IC 320 effect a drift of the base-emitter voltages and with this a drift of the operating point which effects then a higher distortion of the sine wave signal at the output RF SINE.

In order to keep the crystal temperature of IC 320 constant, there is a temperature control circuit in the sine shaper which consists of the transistors 372, 373 and three transistors in IC 320. With potmeter 684 a base current is adjusted for transistor 320/12, 13, 14. The collector of this transistor controls the two parallel connected 'heating transistors' 320/1, 2, 3 and 320/3, 4, 5 – which produce a heating power of together appr. 0.3 W – via transistors 373 and 372.

In case of increasing crystal temperature in IC 320, the current through transistor 320/12, 13, 14 will also increase and reduce the heating power of transistors 320/1, 2, 3 and 320/3, 4, 5 via the transistors 373 and 372.

In this way there is a closed control loop which effects a crystal temperature of appr. 80 – 85° C remaining absolutely constant – this is essential for a proper sine wave forming.

The output signals of the differential amplifier 320/9, 10, 11 and 320/6, 7, 8 are fed to the bases of transistors 374 and 376. After amplification in this sine output amplifier the output amplitude is adjusted with potmeter 721 and passed to the modulator via output RF SINE.

6.3. MODULATOR/U1

Voltage Conditioner

The DFS-signals (sine, triangle, rising sawtooth, falling sawtooth) are routed via the voltage conditioner to be conditioned to the final signals e.g. from the bipolar rising sawtooth to the unipolar positive sawtooth signal.

The resistance network of this voltage conditioner and its analogue multiplexer (301) build up a voltage divider combination with selectable attenuation and dc-shifting. The path a1 (fig. b) is switched on at sinewave and triangular wave, path a2 at negative sawtooth and path a3 at haversine or positive sawtooth waveforms respectively (due to the inverting OUTPUT AMPLIFIER/U1 the polarities of the signals in the MODULATOR are invers with respect to the generator output signals).

The attenuations of a2 and a3 are double of that of a1, their positive or negative dc-shifting, respectively, comes to half the value of the resulting amplitudes of the signals. Both these facts result in unipolar sawtooth signals and in equal zero to peak amplitudes of all signals derived from the DFS waveforms.

Diode Switches

The principle of operation of the DIODE SWITCHES 1 and 2 is shown in the figure below (fig. a)

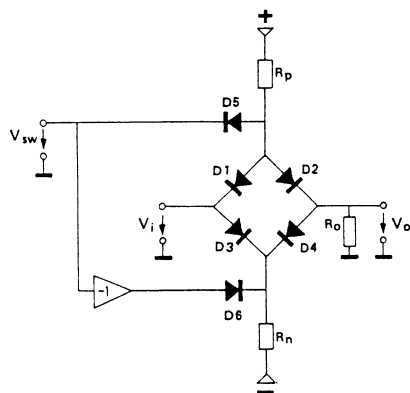

- V_i = input signal voltage
- V_o = output signal voltage
- V_d = diode forward voltage
- V_{sw} = switching voltage

fig. a

If V_{sw} is negative, D5 and D6 are open and the bridge diodes are closed. R_o pulls the output voltage to 0 volts.

If V_{sw} is positive, diodes D5 and D6 are closed, the diode bridge D1 . . . D4 is open, and the voltage relations are

$$V_{d1} + V_i = V_{d2} + V_o$$

$$\text{and } V_i - V_{d3} = V_o - V_{d4}$$

So the output voltage V_o is

$$V_o = V_i + V_{d1} - V_{d2} = V_i + V_{d4} - V_{d3}$$

$$\underline{V_o = V_i} \quad (\text{if } V_{d1} = V_{d2} \text{ and } V_{d3} = V_{d4})$$

Differences of the diode voltages can cause an offset which is compensated at the general offset adjustment of the generator. The load resistance for the signal voltage source (V_i) is R_o shunted by R_p and R_n .

Besides the selection of the right signal paths the DIODE SWITCHES perform the signal keying at GATING mode. DIODE SWITCH 1 is driven by a balanced, non saturated differential driver (358, 360). DIODE SWITCH 2 is driven by two coupled transistor switches operating in opposite directions (362, 364 and 363, 366).

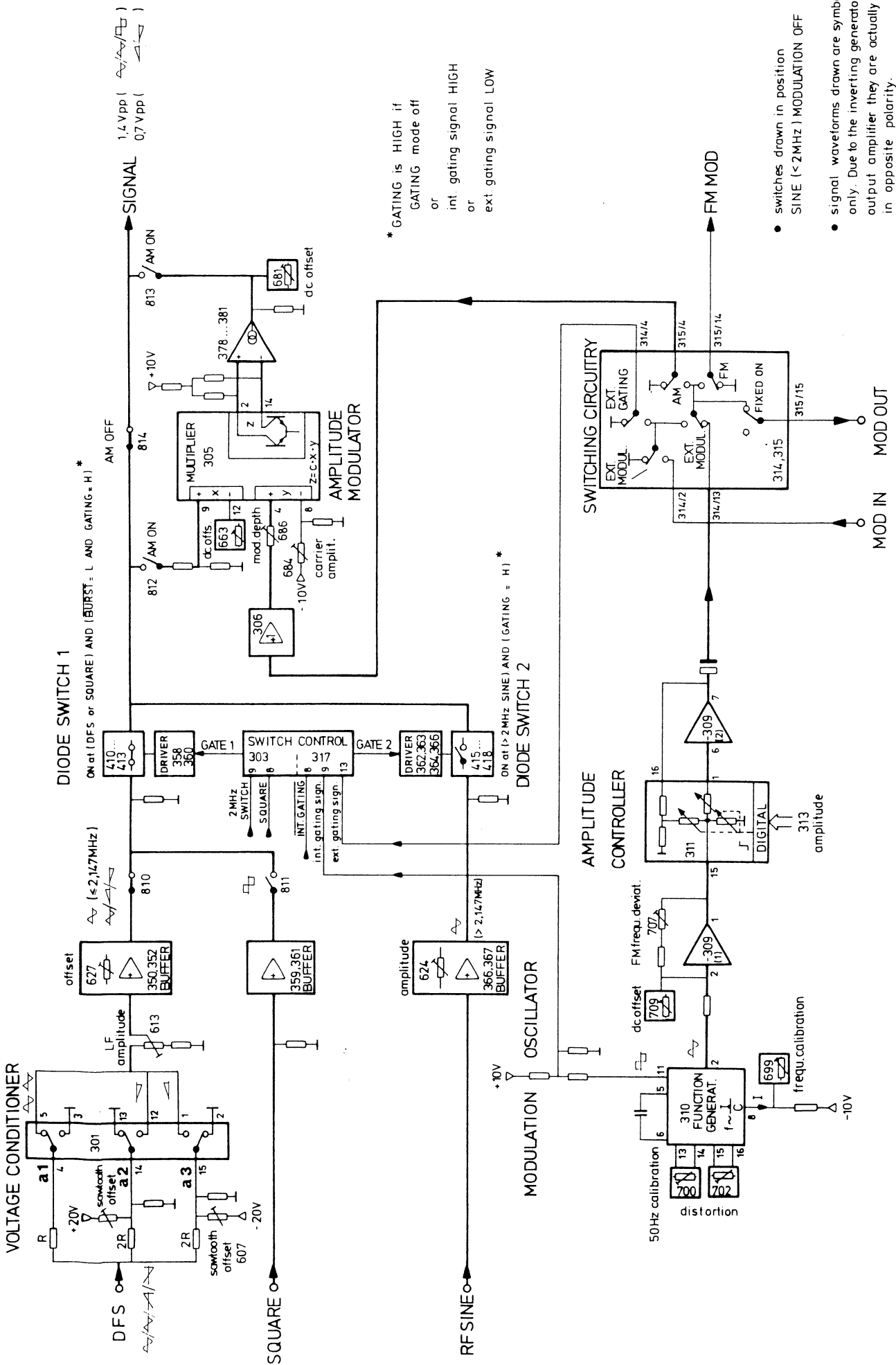

MODULATOR/U1 FUNCTIONAL DIAGRAM (fig.b)

Switch control

Both the DIODE SWITCHES are controlled by logical control signals and the GATING signal, all them logically linked in the SWITCH CONTROL circuit, a combination of NOR-gates. The linkage of the control signals is explained by the equivalent logical equations below (+ = OR, x = AND):

$$\text{GATE1} = (2 \text{ MHz SWITCH} + \text{ SQUARE}) \times (\overline{\text{INT GATE}} + \text{int. gating sign.}) \times \overline{\text{ext. gating sign.}}$$

$$\text{GATE2} = \overline{2 \text{ MHz SWITCH}} \times \overline{\text{SQUARE}} \times (\overline{\text{INT GATE}} + \text{int. gating sign.}) \times \overline{\text{ext. gating sign.}}$$

Represented as a combination of contacts:

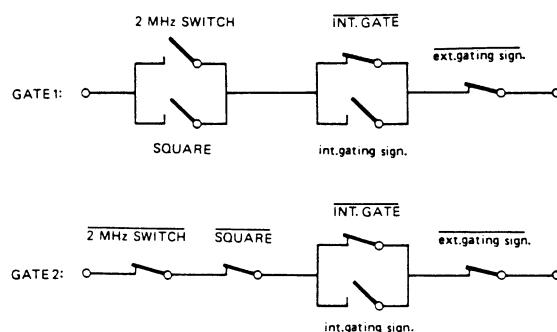

fig. c

Symbols:

- 2 MHz SWITCH: HIGH (ON) if frequencies < 2.147 MHz (control line)
 SQUARE: HIGH (ON) if SQUARE waveform selected (output pin 14 of shift register 302).
 $\overline{\text{INT GATE}}$: HIGH (ON) if any other modulation mode is selected than INTERNAL GATING (output pin 7 of shift register 316).
 int. gating sign.: H and L (ON and OFF) change with the internal gating signal (square wave output of the modulation generator).
 ext. gating sign.: H and L (OFF and ON) change with the external gating signal. Kept LOW (ON) if external gating mode is switched off.
 GATE1/2: Driving signals for the DIODE SWITCHES 1 and 2 (= output signals of the SWITCH CONTROL circuit, see fig. b). HIGH: SWITCH ON, LOW: SWITCH OFF.

Amplitude Modulator

AM is performed by multiplication. The multiplier module (305) multiplies the carrier signal (any generator signal) by the internal or external modulation signal. The modulation signal is superposed by a dc-component (pin 8). The level of this dc-"offset" with respect to the ac input amplitudes (pin 9 and pin 4) determines the proportion between the amplitudes of carrier and both the sidebands. At 0 volts dc the carrier would be suppressed (balanced modulation).

The function of the complete AMPLITUDE MODULATOR circuit is represented by the following equation (for sinusoidal voltages):

$$u_{\text{out}} = k \times (E_c \cos \omega_c t \times (V_{\text{dc}} + E_m \cos \omega_m t))$$

- Symbols: u_{out} = modulated output signal
 $E_c \cos \omega_c t$ = carrier signal
 $E_m \cos \omega_m t$ = modulation signal } E = amplitude
 V_{dc} = dc voltage (at pin 8)
 k = scaling factor, resulting from the parameters of the complete AM-modulator circuitry

Evaluated:

$$u_{out} = k \times (E_c V_{dc} \cos \omega_c t \times E_c E_m (\cos \omega_c t \times \cos \omega_m t))$$

$$= k \times E_c (V_{dc} \cos \omega_c t + E_m \times 0.5 (\cos (\omega_c - \omega_m) t + \cos (\omega_c + \omega_m) t))$$

carrier
lower sideband
upper sideband

The right relations between k, V and E, obtained by suitable dimensioning and proper calibration, result in

$$u_{out} = 0.5 E_c (\cos \omega_c t + 0.5 m (\cos (\omega_c - \omega_m) t + \cos (\omega_c + \omega_m) t))$$

(m = E_m/E_{m max} = depth of modulation)

Modulation Oscillator

The main unit of the MODULATION OSCILLATOR is a function generator module (310). The current drawn from pin 8 of this IC and the capacitor connected to pins 5 and 6 determine the output frequency. Current sink (approx. 0.1 mA) and capacitor (33 nF) are dimensioned for a fixed frequency of 1 kHz.

The sinewave output signal is routed via a buffer amplifier (309 (1)), which gives also possibilities for amplitude and offset calibrations, to the AMPLITUDE CONTROLLER, a circuit consisting of a DAC and an operational amplifier (311, 309 (2)). The DAC is applied as controllable feedback resistor network for the operational amplifier.

The rectangular output signal of the function generator (pin 11) is routed to the SWITCH CONTROL circuit. It becomes effective as internal gating signal if the INTERNAL GATING mode is switched on.

Control of the Modulator Unit

Three 8-STAGE SHIFT-AND-STORE BUS REGISTERS, joint in cascade (302 → 316 → 313; see fig. 39), distribute the control messages of the CPU (SDA) – 32 bits serial, coming in via register module 302 – to the corresponding switches and control modules respectively. With strobe STR9 going HIGH that string of bits clocked in by the serial clock (SCL) is transferred to the outputs of the register modules in parallel (latched) and, thereby, to the switches, multiplexers, gates etc.

Register module 313 hands over the control bits for amplitude setting of the modulation oscillator. Register modules 302 and 316 hand over the control bits for selection of the different signal paths and modulation modes (see tables below):

4	5	6	7	14	13	12	11
0	1	0	1	0	0	0	0
0	1	1	0	1	0	0	0
0	0	1	1	0	0	0	0
1	1	1	1	0	0	0	0

Shift register 302

4	5	6	7	14	13	12	11	
1	1	1	1	1	1			MODULATION OFF
0	0	1	1	1	1			internal AM
1	1	0	1	1	1			internal FM
1	1	1	0	1	1			internal GATING
0	0	1	1	1	0			external AM
1	1	0	1	1	0			external FM
1	1	1	1	0	0			external GATING

*) modulation frequency

Shift register 316

6.5. AMPLIFIER / U1

As depicted in the over-all block diagram, fig. 30, the **AMPLIFIER** comprises the sub-sections **AMPLITUDE CONTROLLER**, **POWER AMPLIFIER**, **STEP ATTENUATOR** and **DC GENERATOR**.

Amplitude controller

Corresponding to fig. a, the input voltage is 1.4 Vpp. for sine, triangle and square waves, 0.7 Vpp for the other wave forms.

The ac currents fed into the emitters of 365 and 368, representing current sinks, are proportional to the total effective conductance between buffer output and current sinks. There are 2×7 conductances, namely y_1, y_2, \dots, y_7 and y_1', y_2', \dots, y_7' with binary weights 1, 2, 4, ..., 64. Two additional conductances y_8 and y_8' , weighted 83, complete the switched conductance ladder. Depending on the programmed voltage pp, some of the conductance pairs y, y' are connected by the switches $S_1 \dots S_8$ and $S_1' \dots S_8'$ with the current sinks.

Example:

for 10 Vpp, switches S_3, S_6, S_7 and S_3', S_6', S_7' are closed. The effective conductance is then about $y = 1/(134 \text{ ohm})$. If 20 Vpp is programmed. All switches excl. S_2, S_4 and S_2', S_4' are closed, resulting in $y = 1/(67.2 \text{ ohm})$. The generator open loop output voltage is $V_o = ayV_i$ where $a = 960 \text{ ohm}$ in the 2.1 to 20 Vpp range.

Thus $y_0 = 20 \text{ Vpp}$, if $y = 1/(67.2 \text{ ohm})$.

Resistor 632 is lowering the input impedance of the emitter current sinks, thus improving the amplitude-controller linearity.

In the real circuitry, see fig. 38, the switches are realized by the diodes 424 ... 439. In the switch-off state, the diodes are biased reversely to about 1.3 V by transistors, e. g., diode 424 by transistor 333. Primary control is performed by shift register 302 via CMOS switches 314, 315.

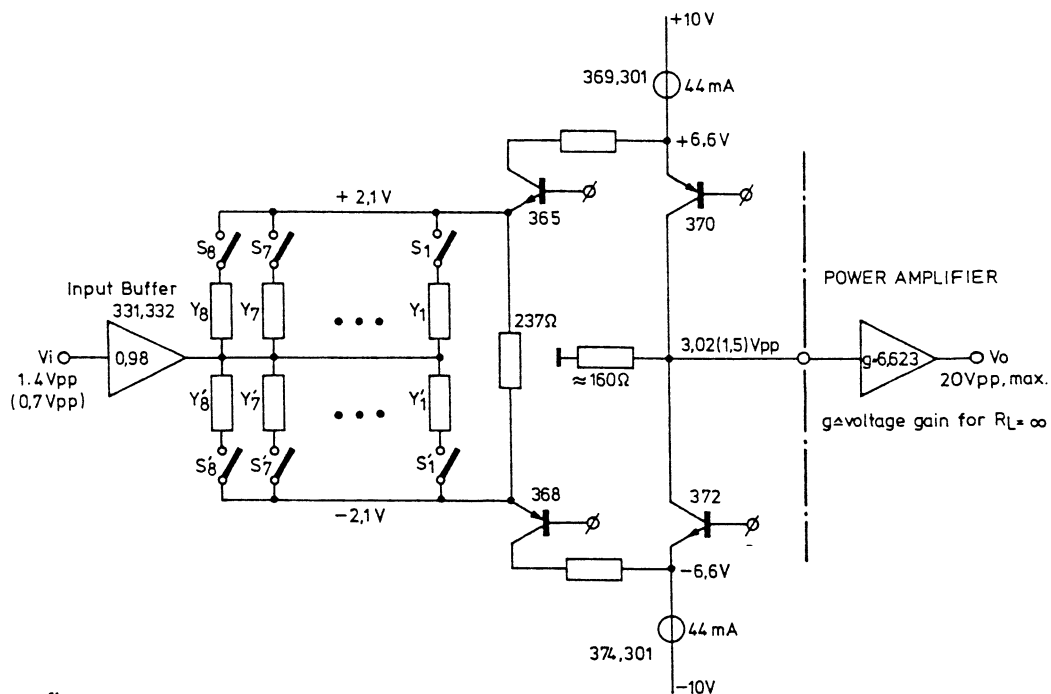

fig. a

Power amplifier

As depicted in fig. b, the **POWER AMPLIFIER** is a complementary collector-output type. At frequencies above some hundred Hz the ac input voltage is passed through the input buffer and C536, C537 directly to the base of transistors 378 and 381, converted to ac currents by 378 . . . 383 and fed through 385, 386, 387 and 390, 391, 392 respectively to the internal 50 Ohm output resistor, made up by the resistors 781 . . . 786.

For high dc stability, the difference of the emitter dc currents (378, 379, 380 vs 381, 382, 383), which is about zero, is kept constant by an automatic control loop including OP 303 and transistor 377.

This loop is forcing $i_1 - i_2 \approx V_i$ in the frequency range from dc to some hundred Hz. Trimmer 700 is adjusted for flat amplitude response in the take-over range of the direct drive via C536 and C537.

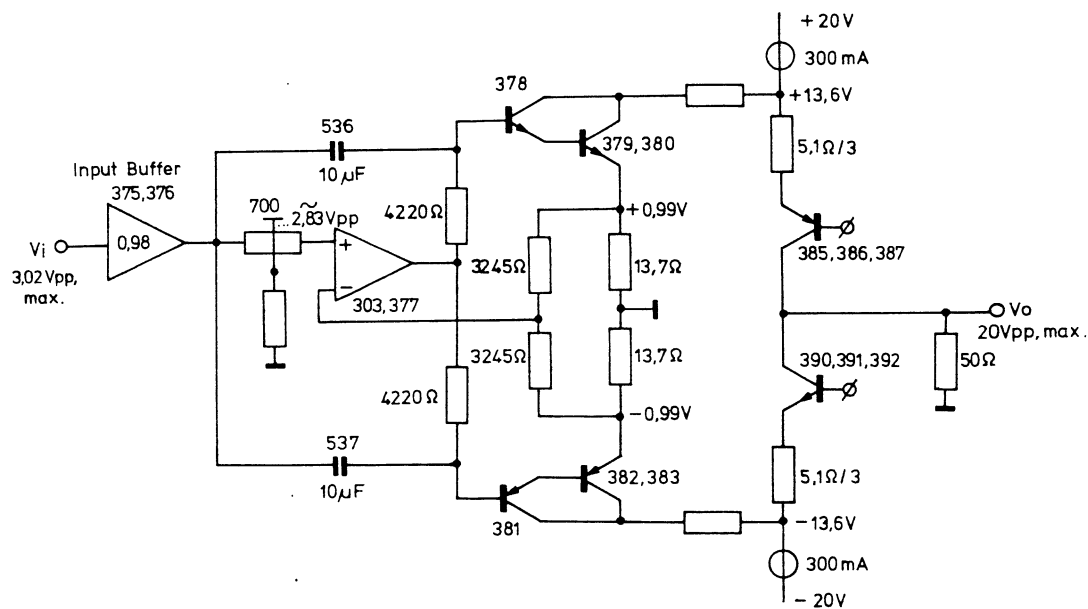

fig. b

DC generator

Primary control of the **DC GENERATOR** is performed by the DAC, Pos. 307. The DAC is set by shift register 306 to output currents I_0 from 0 to about $200 \cdot I_{ref}/255 = 0.884$ mA proportional to the decimal equivalents 0 . . . 200 of the shift register binary output. If the decimal equivalent is 100, i. e. DC = 0V, $I_0 = 0.442$ mA is compensated by the current through resistors 770, 771. 771 is adjusted for DC = 0V at the generator output. Hence, in this situation no current is drawn from the input (pin 6 of OP 308) of the dc generating circuitry. If the shift register output is 0 or 200, i. e. DC = - 10 V or + 10 V respectively, the asymmetry of the emitter voltages (transistors 394, 395 vs 397, 398 is $U = I_{0max} R/4 = 5.5$ V ($I_0 = 0.884$ mA, $R = 24.9$ kOhm; resistors 777 . . . 780), giving a dc voltage at the generator output of $4 \cdot U \cdot RL/r = 10$ V absolute. ($RL = 50$ Ohm, $r = 110$ Ohm; resistors 868, 869 etc.). The corresponding output current of the DC GENERATOR is $4 \cdot U/r = 200$ mA.

6.6. CPU / U2

The CPU of the PM 5192 contains the μ -processor 8031 with all drivers, decoders, RAM- and PROM memory, clock generator, IEC-bus interface, strobe-decoder and the control outputs PEN LIFT and SWEEP OUT.

The multiplexed address/data bus (AD0 – AD7) of the processor 318 supplies the address inputs A0 – A7 of the PROM-memory 315 via the address latch 314 (74LS363), the inputs A8 – A13 are supplied directly from the processor (P20 – P25). Data from the PROM is fed from the outputs O₀ – O₇ via the lines AD0 – AD7 directly to the processor, this transfer is controlled with the output PSEN from the processor driving the input OE of the PROM.

The memory circuits 324 and 325 serve the storing of the parameter sets (store function). Communication with them takes place via the internal serial I²C bus which consists of a data line SDA and a clock line SCL. The principle of the data transfer between processor and the RAM-memories is shown in the following diagram.

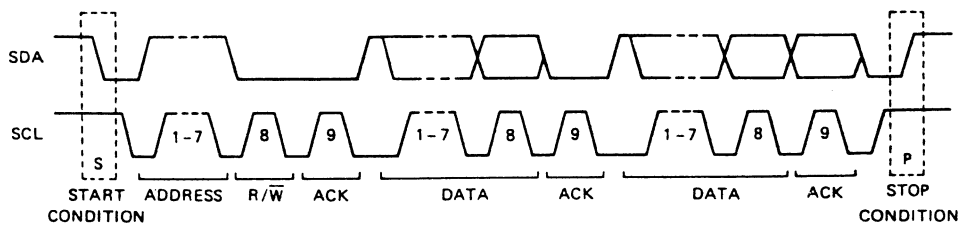

The line SDA and the line SCL for the C-bus (output T x d of the processor) serve the communication with the remaining units. The data information of the line SDA is clocked into the shift register of each unit, the according strobe signal following this data sequence latches the data information in the selected shift register and presents the transmitted information in parallel form at the output lines of this circuit. The required strobe signals are generated with the strobe-decoder 312 which is controlled again from the processor via the lines P20 – P23 and the signal WR.

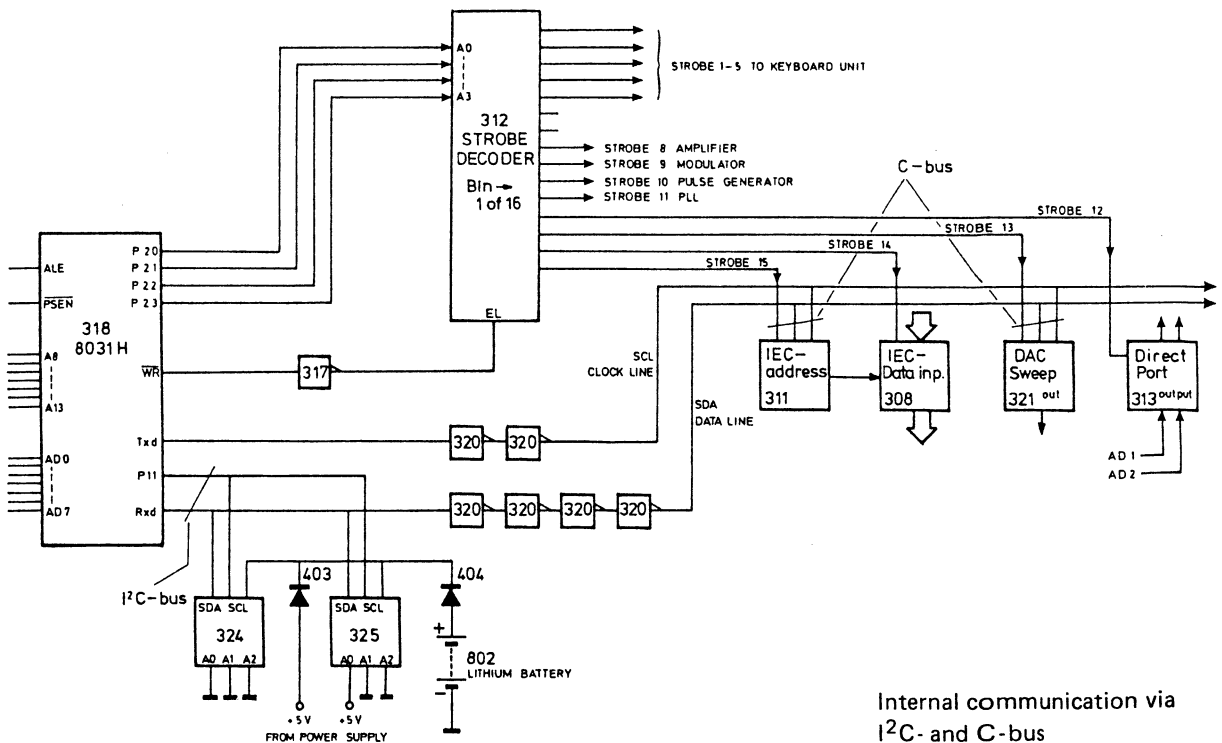

Internal communication via I²C- and C-bus

Converting the serial information to a parallel one the parallel output presents the decoded commands.

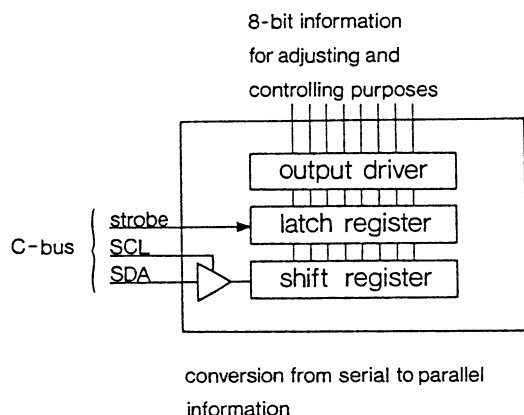

The clock signals for processor and IEC controller as well as a 100 kHz signal for the internal timer are generated in the 'clock generator' circuitry. This part of the CPU consists of the crystal 801, the inverter 317 and the decimal counter 319. The 10 MHz clock from the inverting buffer is fed to input XTAL 1 of the processor, furthermore divided by 5 with the decimal counter 319 and then fed to the IEC-controller 306. After further dividing by 20 the output 7 of the counter delivers the 100 kHz signal T₀ for the timer.

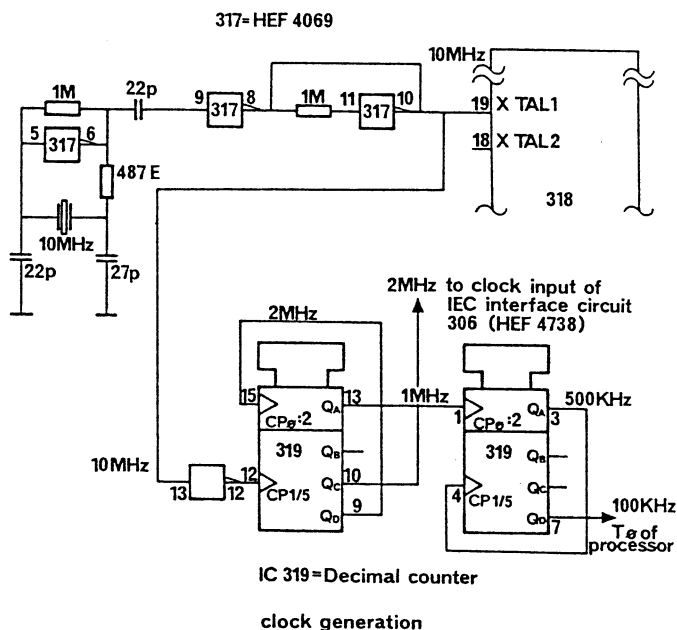

Remote control of the PM 5192 follows via the IEC-interface which consists of the controller 306, the bus drivers 301 – 304, the buffers 307, 308 and the shift registers 309 – 311. Input data (control commands) from the IEC-bus connector are fed to the data bus AD₀ – AD₇ via the bidirectional bus drivers 303 and 304 and buffer 307. Output data (learn- and identification mode) are accordingly fed to the IEC-bus via buffer 308 and the bus drivers 303 and 304. Data direction and enable of the buffers are controlled by the IEC-bus controller 306 via the output O_{ta} (other talk address) and by the processor with the signal 'STROBE 14'.

The listener/talker addresses and the interface parameters necessary for the communication are sent to the IEC-controller in serial form. The microprocessor sends these informations via the C-bus with the help of the signal STR 15 to the shift register 311. The parallel outputs of this circuit supply again the parallel inputs of the shift registers 309 and 310 by means of which addresses and interface parameters are transferred to input 'ISR' (input shift register) of the IEC-bus controller. This transfer action is controlled from the controller circuit, the repetition rate is 125 kHz ($= 2 \text{ MHz}/16$).

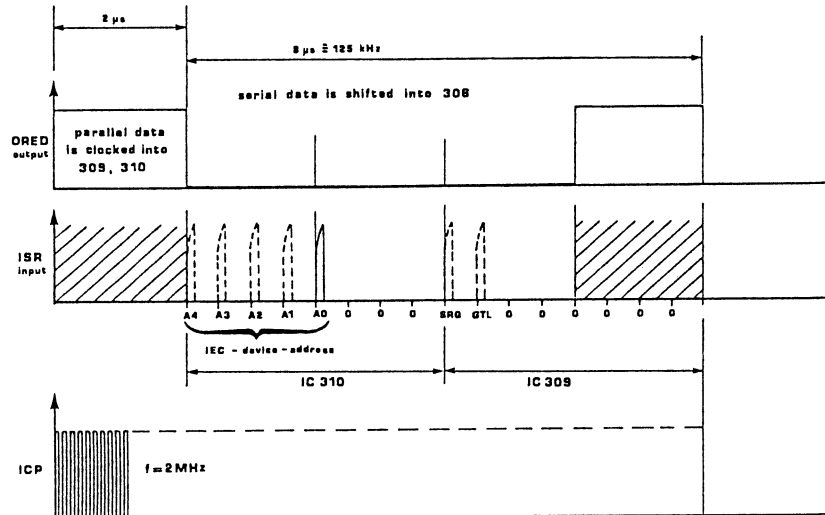

Each data string for the shift registers 309 and 310 contains the IEC device-address and one bit for SR0 on or off. The data string entered from the IEC controller 306 via input 'ISR' has a length of 11 bits, not required bits at the inputs of ICs 309/310 are fixed to ground. Input GTL of these circuits – pin 15 of IC 309 – is controlled directly from the key LOCAL at the front panel. Pressing this key causes the IEC controller 306 to switch back to the local mode.

The output SWEEP OUT contains a frequency-proportional voltage during the linear sweep and a log-frequency proportional voltage during the logarithmic sweep. This output voltage is generated by means of a shift register with a DAC controlled directly from the processor via the C-bus.

The digital information is transferred to the shift-register and presents the parallel information at the outputs when the strobe-signal 'Strobe 13' becomes true. The 8 output-lines of the shift-register 321 are fed directly to the input lines of the DAC 323 which forms the 8-bit digital information to an analog signal which is then – amplified by the operational amplifier 322 – fed to the SWEEP OUT connector.

The Direct Port consists of the latch circuit 313 which is used to latch informations from the lines AD1, AD2 and which is controlled with the signal STR 12. The output-signals '2 MHz-SWITCH' and 'PLL-CNTL' are used for controlling purposes in the units PLL/VCO and modulator.

6.7. KEYBOARD DISPLAY UNIT / U3

Unit 3 of the synthesizer PM 5192 contains LEDs keys and display elements with their concerning driver/decoder circuits. Data transfer from the CPU to the keyboard/display unit takes place via the C-bus (SDA, SCL, STROBE 1 – 5), input data from the keyboard is sent as a sequence of 12 pulses from the keyboard encoder 353 via the line SKC to the CPU. The key 'LOCAL' is directly led to the IEEE/IEC interface on unit 2 via line GTL.

Display data are sent in 34 bit data blocks via the C-bus to the according part of the display unit, selection (= addressing) of this part is done with one of the strobe signals STROBE 1 – STROBE 5. During the data transfer from the CPU to the keyboard/display unit the according strobe line is set and a 34-bit data block is loaded into the shift register with the clock signal SCL. The last bit at the data input shifts the complete data set into the latch register and therewith to the display elements/LEDs via the buffer stage.

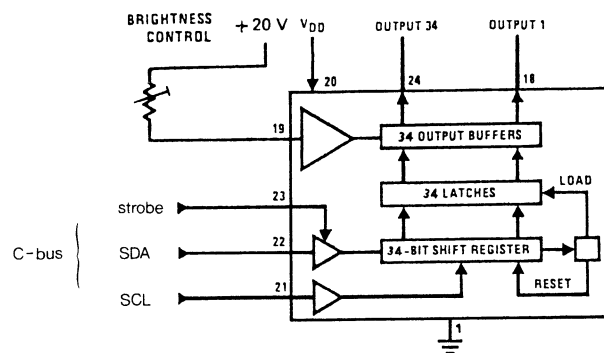

Each of the five strobe lines controls the data transfer to one of the display groups:

- STROBE 1 display circuit 408 for amplitude, V_{dc} , address and the LEDs in the keys 'Vrms' and 'ADDRESS'
- STROBE 2 display circuit 407 for modulation parameters and the LED in the key 'TIME(s)'
- STROBE 3 display circuit 406 for frequency display (right part) and the LEDs in the keys 'START' and 'STOP'
- STROBE 4 display circuit 405 for frequency displays (left part)
- STROBE 5 LED driver circuit 352

Voltage supply for the LEDs and displays comes from the + 5 V which is reduced to + 3 V (= V_L) by means of the transistor 301 and the resistors 602 and 603

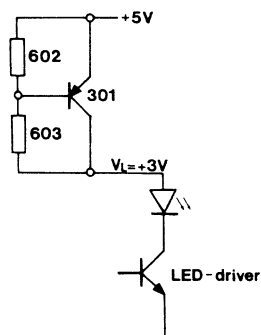

the transistor 301 is placed behind the front plate at a spacing piece beside the socket TTL OUT.

Brightness of the LEDs/displays is adjusted with a reference voltage at the inputs BC (= brightness control) of the driver circuits. These reference voltages are derived from the + 20 V supply by means of the resistors 604 – 608 feeding currents into the BC-inputs.

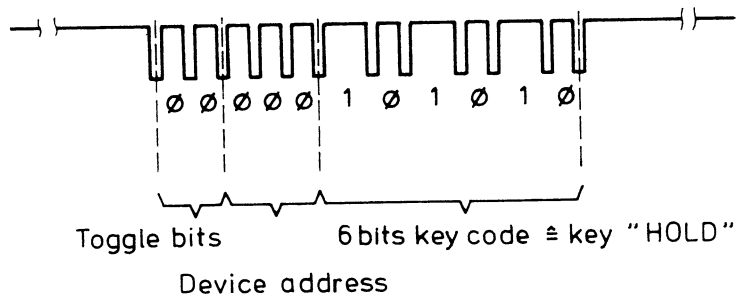

Input from the keyboard takes place with the help of the keyboard encoder IC 353 (= SAA 3007) which controls the 8 x 8 keyboard matrix and sends the keycode in serial form from the output REMO via line SKC to the CPU. During the rest condition the sense lines SEN0 – SEN6 are 'high', the drive lines of the matrix DRV0 – DRV6 are 'low', the last drive line is fixed to ground.

When a key is pressed the according sense line is forced to 'low', the internal logic of the encoder starts the scan of the matrix and transmits a sequence of 12 pulses whereby the distance between two pulses means binary "0" or "1".



Each time a key is pressed such a bit sequence must be measurable at line SKC (= pin 10 of the CIS connector). The toggle bits of this message are incremented by 1 each time when a key is pressed. Thus it is possible to distinguish between a key being pressed several times or once for a longer time.

The device address is fixed to "000" and the last 6 bits show the following pattern by pressing the corresponding key

Key	Connection between	Key code	Key	Connection between	Key code
	DRV0 – SEN0	000000	LIN	DRV1 – SEN3	011001
	DRV0 – SEN1	001000	LOG	DRV1 – SEN4	100001
	DRV0 – SEN2	010000	TIME (s)	DRV1 – SEN5	101001
	DRV1 – SEN0	000001	SINGLE	DRV2 – SEN3	011010
	DRV1 – SEN1	001001	CONT	DRV2 – SEN4	100010
	DRV1 – SEN2	010001	HOLD	DRV2 – SEN5	101010
AC OFF			Vdc	DRV3 – SEN3	011011
START	DRV3 – SEN0	000011	Vpp	DRV3 – SEN4	100011
Hz/kHz	DRV3 – SEN1	001011	ΔLEVEL	DRV3 – SEN5	101011
–STEP	DRV3 – SEN2	010011			
STOP	DRV4 – SEN0	000100	+/-	DRV4 – SEN3	011100
ΔFREQ	DRV4 – SEN1	001100	dBm	DRV4 – SEN4	100100
+STEP	DRV4 – SEN2	010100	–STEP	DRV4 – SEN5	101100
OFF	DRV5 – SEN0	000101	ADDRESS	DRV5 – SEN3	011101
INT	DRV5 – SEN1	001101	Vrms	DRV5 – SEN4	100101
EXT	DRV5 – SEN2	010101	+STEP	DRV5 – SEN5	101101
GATE	DRV6 – SEN0	000110	STO1-9	⊥ – SEN7	111111
AM	DRV6 – SEN1	001110	RCL0-9	DRV6 – SEN7	111110
FM	DRV6 – SEN2	010110	RUB OUT	DRV4 – SEN7	111100
%	⊥ – SEN1	001111	0	DRV0 – SEN6	110000
DEV (kHz)	⊥ – SEN2	010111	1	DRV1 – SEN6	110001
			2	DRV2 – SEN6	110010
			3	DRV3 – SEN6	110011
			4	DRV4 – SEN6	110100
			5	DRV5 – SEN6	110101
			6	DRV6 – SEN6	110110
			7	⊥ – SEN6	110111
			8	DRV0 – SEN7	111000
			9	DRV1 – SEN7	111001
			"•"	DRV2 – SEN7	111010
			ENTER	DRV3 – SEN7	111011

The clock for the keyboard encoder is generated with the ceramic resonator 860. During the rest condition — i. e. no key is pressed — there is no signal at input 11 or 12 of the keyboard encoder. When any key — except LOCAL — is pressed, the clock supply will be activated and a signal with a frequency of 455 kHz and an amplitude of 4,5 Vpp can be measured at pin 11 or 12. By pressing a key only once for a short moment the clock will be switched on for approx. 170 ms., pressing a key for longer will keep the clock supply switched on as long as the key is pressed.

The line ENK (enable keyboard) at pin 4 of the CIS-connector has a special meaning for the keyboard input. During a running sweep it is not possible to press any key except MOD OFF, SINGLE, CONT or HOLD. These keys contain one more switch contact which is commonly connected to line ENK, only this line is supervised by the processor during a running sweep.

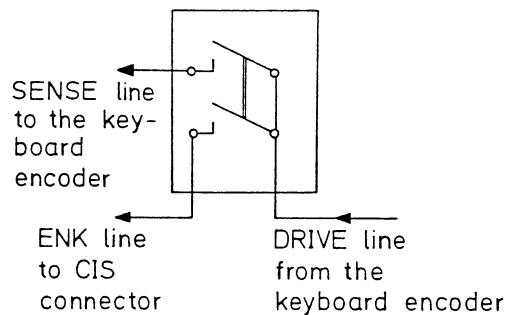

When operating one of these keys the line ENK and the according sense line are forced to 'Low' which effects the keyboard encoder to scan the matrix and to send the key code via the line SKC to the CPU. Only when the processor has recognized via ENK that one of the four keys was pressed, the normal keyboard input via line SKC is started.

7. ACCESS TO PARTS

7.1. TOP AND BOTTOM COVERS (DISMANTLING THE INSTRUMENT)

Before opening the instrument unplug mains connector, take note of chapter 1.5..

- Loosen the cross-slotted screws (A) (Fig. 7-1) at the rear
- Pull top cover (B) as shown in figure 7-1.
- The procedure to remove the bottom cover (C) is the same as above.

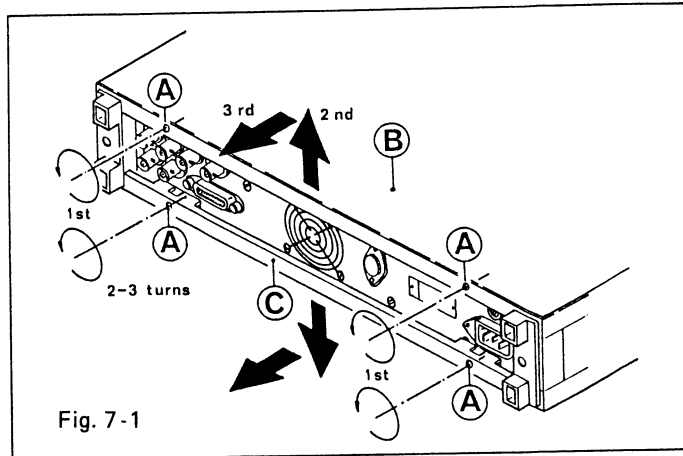

Fig. 7-1

7.2. FUSE, MAINS TRANSFORMER

For mains voltage setting and fuses and the assigned safety instructions see chapter 2.

7.3. UNIT 1 AND UNIT 2

For access to the upper side of unit 2 and the bottom side of unit 1 it is only necessary to remove the top cover respectively the bottom cover of the instrument (see chapter 7.1.).

To reach the upper side of unit 1 and the bottom side of unit 2 proceed as follows:

- Unplug the connector (G) (Fig. 7-5) on the right hand side of unit 2.
- Remove 2 screws (A) (Fig. 7-5) at the sides of the instrument.
- Lift the pcb as arrow (C) shows in Fig. 7-5. (If it is heavy to move the pcb, loosen the screws at the pivot a little bit.).
- Fixing unit 2 in an upright position insert screw (A) in position (H) (Fig. 7-5).
- The other steps shown in fig. 7-5 are not necessary to reach unit 1 + 2.

7.4. FRONT-PANEL EDGING

- Remove covers (chapt. 7.1.).
- Lift the profile ornament (A) (Fig. 7-2) with a small screw driver.
- Remove the screws (B) (Fig. 7-2).
- Remove the edging (C) (Fig. 7-2).
- For the bottom side the same procedure applies.

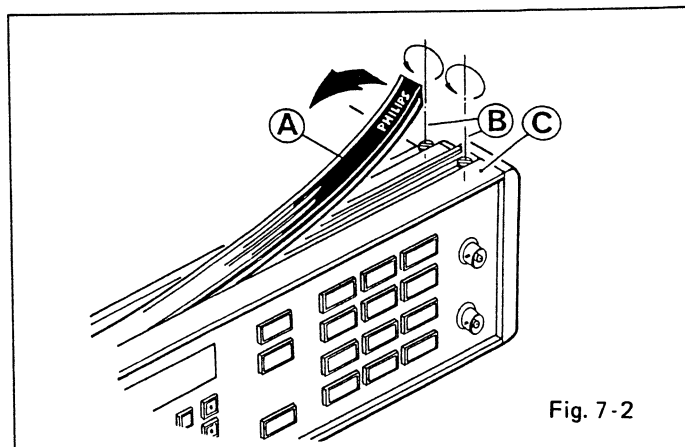

Fig. 7-2

- Remove screws (B) (Fig. 7-3)
- Remove side pieces (A) (Fig. 7-3)

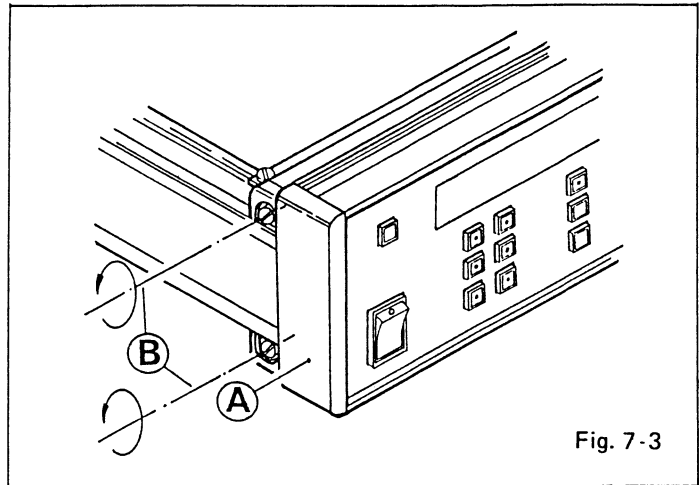

Fig. 7-3

7.5. TEXT PLATE

The text plate (A) (Fig. 7-4) is fixed by three parts of doublesided adhesive tape (B) (Fig. 7-4)

- To remove the text plate insert carefully a screwdriver near the tapes and move the screwdriver as shown in Fig. 7-4.
- Steps described in chapters 7.1 and 7.4. are necessary before.

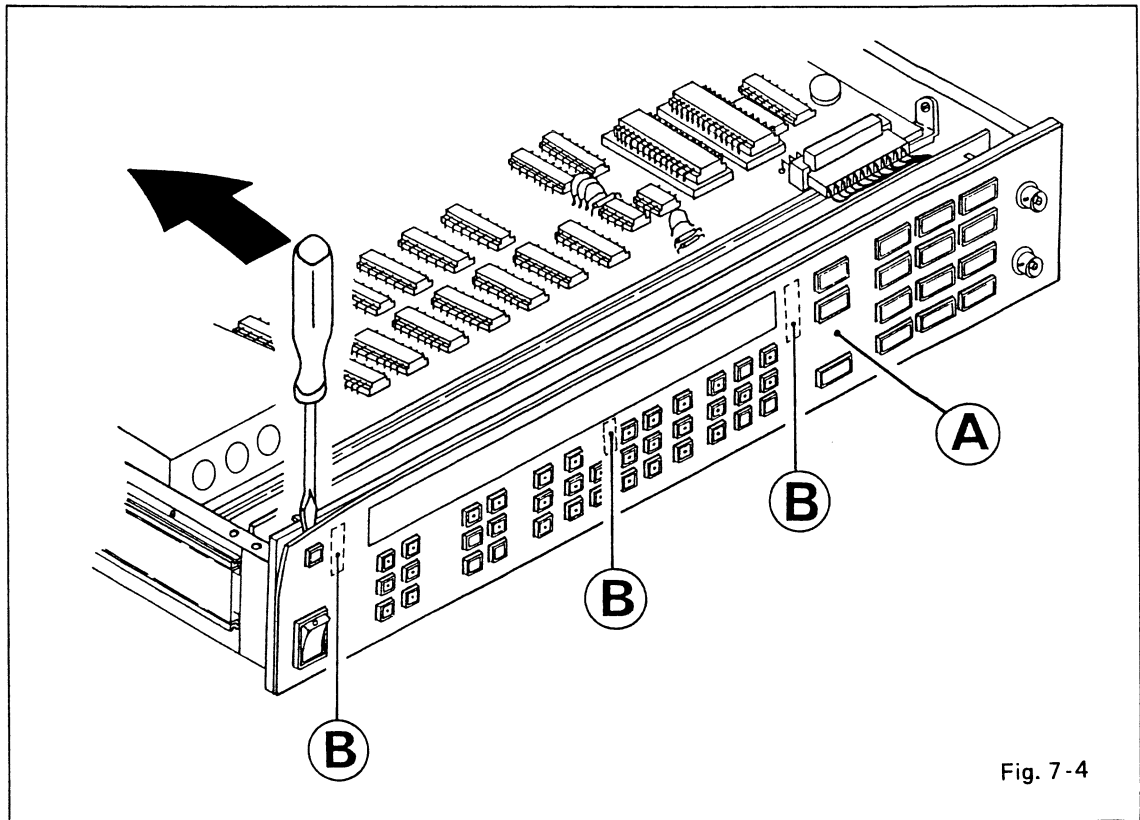

Fig. 7-4

7.6. UNIT 3 (KEYBOARD AND DISPLAY)

At first steps described in chapters 7.1., 7.4. and 7.5. must be done

- Unplug connector **(G)** (Fig. 7-5)
- Loosen all screws **(F)** (Fig. 7-5) at the front of the instrument
- Pull carefully frontplate **(E)** (Fig. 7-5) forwards, take care of the wires of the BNC-connectors and the main switch
- Remove unit 3 **(D)** (Fig. 7-5)
- The other steps shown in this figure are not necessary to reach unit 3.

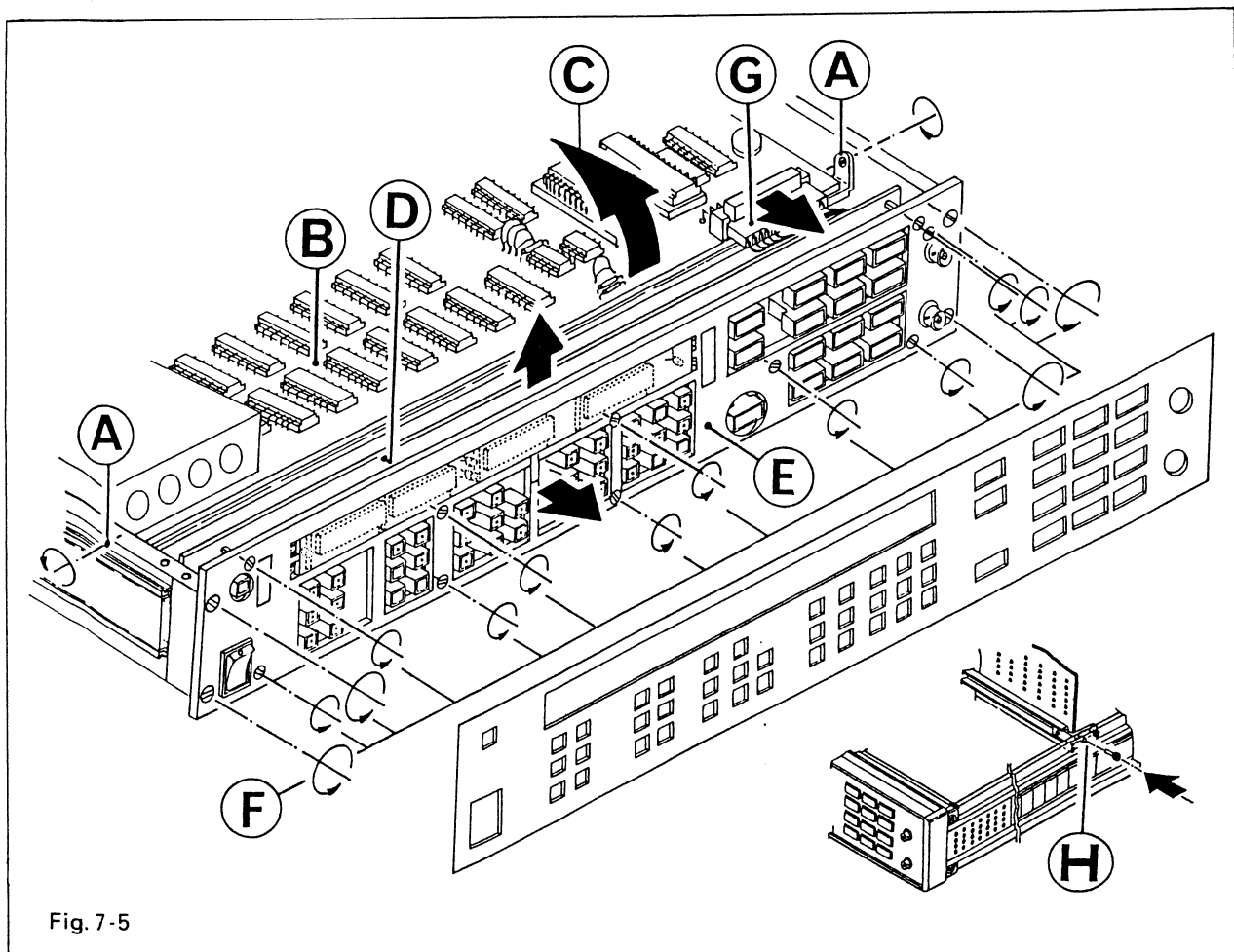

Fig. 7-5

7.7. CARRYING HANDLE

- Lift the carrying handle.
- Prise off carefully both plastic profile strips next to the handle in the similar way as the profile ornament of the front-panel edging shown in Figure 7-2.
- Loosen cross-slotted screws of the holder for handle.

7.8. HANDLE ASSEMBLY FOR RACK MOUNTING

- Remove top and bottom covers as described in chapter 7.1.
- Loosen screws (B) (Fig. 7-6).
- Remove side piece (C)
- Fit handle (A), refit screws (B)
- For the right hand side the same procedure applies.
- Close the instrument

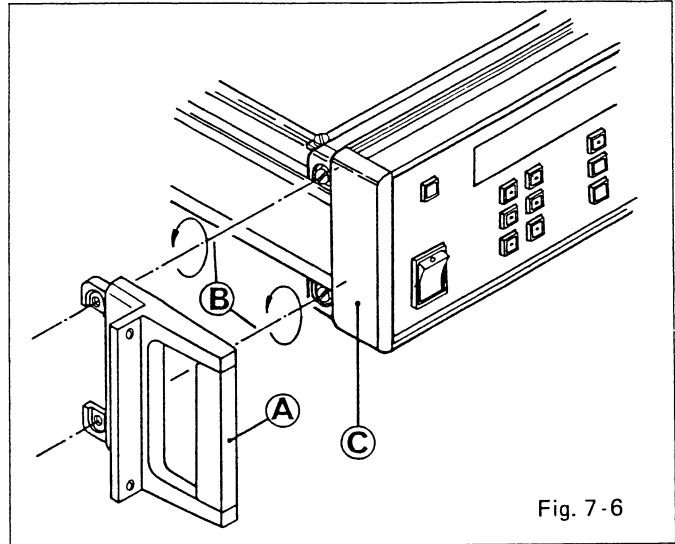

Fig. 7-6

7.9. VIEW INTO THE OPEN INSTRUMENT



PM 5192 without top cover

8. CHECKING AND ADJUSTING

8.1. GENERAL INFORMATION

The following information provides the complete check and adjustment procedure for the instrument. As various control functions are interdependent, a certain order of adjustment is often necessary. The procedure is, therefore, presented in a sequence which is best suited to this order, cross-reference being made to any circuit which may affect a particular adjustment.

Before any check, the instrument must attain its normal operating temperature.

- Warm-up time under average conditions is 30 minutes.
- Adjustments should be made after 2 hours
- Ambient temperature $(23 \pm 1)^{\circ}\text{C}$
- Mains voltage, nominal values $\pm 10\%$
- The cabinet must be closed.*
- Where possible, instrument performance should be checked before an adjustment is made.
- All limits and tolerances given in this chapter are calibration guides, and should not be interpreted as instrument specifications unless they are also published in chapter 1.2. of the Operating Manual.
- Tolerances are given for the instrument under test and do not include test equipment error.
- If not explicitly stated otherwise, the voltage potentials refer to the relevant contact measured against measuring earth.

8.2. RECOMMENDED TEST EQUIPMENT

The following instruments are necessary to provide check and adjustment of the PM 5192

- $50\ \Omega$ termination resistor PM 9581 (1 W)
- wide band oscilloscope ($t_r \leq 1\ \text{ns}$)
- DC-voltmeter: resolution $\leq 100\ \mu\text{V}$ e. g. PM 2528
- counter 20 MHz, intervall-measurements, 8 digits resolution, e. g. PM 6665
- spectrum analyzer e. g. Takeda Riken 4132
- rms voltmeter: resolution 1 mV, $f_{\text{max}} = 3\ \text{MHz}$ e. g. Fluke 8920 A; the connection cable together with the termination resistor must have an impedance of exactly $50\ \Omega$
- distortion meter e. g. PM 6309
- power meter e. g. HP438A with probes HP8482A and HP8484A
- modulation meter e. g. Rhode + Schwarz FAM
- service kit
consisting of notch filter 100 kHz, low pass filter 5 kHz, adjustment covers and two adapter cables; to be ordered from SC Hamburg without service code number

* For adjustments special covers with holes for the adjusting elements are required. This parts are included in the service kit.

a = adjustment
c = check

8.3. TABLE OF CHECKS AND ADJUSTMENTS





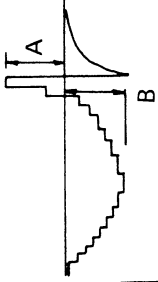

Step	Objective	C = check	a = adjustment	operation parameters settings	adjusting elements	measured value, value to be adjusted	test point, output measuring instruments	open output/50Ωterm.	comment
POWER SUPPLY ADJUSTMENT									
1	+ 5 V supply	c		~ /1kHz/10Vpp	-	5 ± 0.25 V	T1/6, DC-voltmeter (DVM)	-	
2	± 10V supply	c (a)		~ /1kHz/10Vpp	612/615, power supply	± 10 ± 0.1 V	T1/1, 2, DC-voltmeter (DVM)	-	
3	± 20V supply	c (a)		~ /1kHz/10Vpp	604/609, power supply	± 20 ± 0.2 V	T1/3, 4, DC-voltmeter (DVM)	-	
DFS ADJUSTMENT									
4	Frequency adjustment	a		□ /1MHz/5Vpp	505, DFS unit 2	1 MHz ± 0.3 Hz	OUTPUT connector, counter	50 Ohm	
5	DFS-glitches	a		~ /100kHz/10Vpp see comment	676/689, DFS unit 2	minimum AC level	OUTPUT connector, notch filter	50 Ohm	the generator frequency must be exactly the same as the frequency of the notch filter
DC-ADJUSTMENT									
6	DFS DC-offset	a		~ /1kHz/10Vpp	693, DFS unit 2	0 ± 1 mV	T20 unit 1, DC-voltmeter	-	
7	DC-generator voltage	a		~ /1kHz/0Vpp/+10VDC/AC OFF	771, amplifier unit 1	+ 9.9 V ± 5 mV	OUTPUT connector, DC-voltmeter	open	
8	DC-generator voltage	a		~ /1kHz/0Vpp/0VDC/AC OFF	769, amplifier unit 1	0 ± 5 mV	OUTPUT connector, DC-voltmeter	open	
9	offset, amplifier preliminary stage	a		~ /1kHz/10Vpp/jumper S13* open	809, amplifier unit 1	0 ± 1 mV	T14 amplifier, DC-voltmeter	-	
10	offset difference	a		~ /1kHz/3.2Vpp/jumper S13* open	874, amplifier unit 1	} Δ < 2 mV	OUTPUT, oscilloscope or DVM	50 Ohm	these AC-amplitudes must be switched alternately and very fast (e. g. with an IEC-bus controller) in order to get a visible signal
11	offset difference	a		~ /1kHz/6.4Vpp/jumper S13* open	874, amplifier unit 1				
12	offset	a		~ /1kHz/3.2Vpp/jumper S13* open	666, amplifier unit 1	} Δ < 100 mV	OUTPUT, oscilloscope or DVM	50 Ohm	
13	offset	a		~ /1kHz/6.4Vpp/jumper S13* open	666, amplifier unit 1				
14	max. offset difference	a		~ /1kHz/3Vpp . . . 20Vpp in steps of 1 V jumper S13* open	874, amplifier unit 1	Δ < 40 mV	OUTPUT, DVM	50 Ohm	
15	average output offset	a		"	666, amplifier unit 1	0 ± 10 mV	OUTPUT, DVM	50 Ohm	
16	output offset	c		"	-	0 ± 40 mV	OUTPUT connector, DC-voltmeter	open	if the offset value is outside the limit of ± 40 mV, repeat steps 10 and 11
17	output offset difference	a		~ /1kHz/jumper S13 open, closed*/MOD OFF/5Vpp	627, modulator unit 1	Δ < 10 mV	OUTPUT connector, DC-voltmeter	open	

* jumper S13 L11

Check adjustment

Step	Objective	Check	operation parameters settings	adjusting elements	measured value, value to be adjusted	test point, output measuring instruments	open output/50Ω term.	comment
LF-AMPLITUDE, DISTORTION								
18	LF-amplitude	a	~ /10 kHz/10 Vpp	613, modulator unit 1	1.767 ± 0.001 Vrms	OUTPUT connector, rms-voltmeter	50 Ohm	
19	LF-amplitude	c	~ /10 kHz/1 Vpp	—	177 ± 3.5 mVrms	OUTPUT connector, rms-voltmeter	50 Ohm	
20	LF-amplitude	c	~ /10 kHz/0.1 Vpp	—	17.7 ± 0.5 mVrms	OUTPUT connector, rms-voltmeter	50 Ohm	
21	amplitudes difference	a	~ /100 Hz, 10 kHz/10 Vpp	700, amplifier unit 1	Δ U < 0.02 dB	OUTPUT connector, rms-voltmeter	50 Ohm	
22	distortion	c	~ /1 kHz/17 Vpp, 20 Vpp	—	< 0.35 %, < 0.45 %	OUTPUT connector, distort.-meter	50 Ohm	
23	DFS-frequency response	c	~ /10 kHz, 1.8 MHz/10 Vpp	—	± 0.3 dB	OUTPUT connector, rms-voltmeter	50 Ohm	if necessary 517 and/or 519 (modulator) may be altered
24	DFS-frequency response	c	~ /10 kHz, 2.147 MHz/10 Vpp	—	± 0.3 dB	OUTPUT connector, rms-voltmeter	50 Ohm	
SAWTOOTH ADJUSTMENT								
25	offset	a	~ /1 kHz/10 Vpp	607, modulator unit 1	 these points must be adjusted to 0 ± 70 mV	OUTPUT connector, oscilloscope	50 Ohm	
26	offset	a	~ /1 kHz/10 Vpp	602, modulator unit 1	1.443 ± 0.025 Vrms	OUTPUT connector, oscilloscope	50 Ohm	
27	rms-value	c	~ /1 kHz/10 Vpp	—	—	OUTPUT connector, rms-voltmeter	50 Ohm	
PLL-ADJUSTMENT								
28	amplitude triangular wave	a	~ /3 MHz/10 Vpp	636, PLL unit 1	12.3 ± 0.1 mVrms	T10 with 50 Ω termination, rms-voltmeter	—	
29	offset	c	~ /3 MHz/10 Vpp	—	- 550 ± 150 mV	T10, DC-voltmeter	—	
30	2nd harmonic	a	~ /20 MHz/10 Vpp	611, PLL unit 1	minimum, < - 31 dB	T10, spectrum analyser	—	
31	2nd harmonic	a	~ /2.5 MHz/10 Vpp	614, PLL unit 1	minimum, < - 36 dB	T10, spectrum analyser	—	
32	PLL control voltage	a	~ /2.5 - 20 MHz/lin. sweep cont/Ts = 0.05 s./10 Vpp	536 (526), PLL unit 1	A ≈ B < 3 V	T22, oscilloscope	—	
33	DC-level, sine shaper — operating point	a	~ /3 MHz/10 Vpp	684, PLL unit 1	700 ± 20 mV	T11 - T12, DC-voltmeter	—	DC-level between T11 and T12.

a = adjustment
c = check

Step	Objective	a = adjustment c = check	operation parameters settings	adjusting elements	measured value, value to be adjusted	test point, output measuring instruments	open output/ 50Ω term.	comment
34	2nd and 3rd harmonics	a	~ /3 MHz/10 Vpp	706, 709, PLL unit 1	minimum, < - 40 dB	OUTPUT connector, spectrum analyser	50 Ohm	
35	2nd and 3rd harmonics	c	~ /10 MHz/20 Vpp	—	minimum, < - 34 dB	OUTPUT connector, spectrum analyser	50 Ohm	
36	2nd and 3rd harmonics	c	~ /10, 15, 20 MHz/20 Vpp	—	minimum, < - 32 dB	OUTPUT connector, spectrum analyser	50 Ohm	
37	output level difference	a	~ /100 kHz, 3 MHz/10 Vpp	721, PLL unit 1	Δ < 0.03 dB	OUTPUT connector, rms-voltmeter	50 Ohm	
38	DC-difference	a	~ /3 kHz, 3 MHz/5 Vpp	624, modulator unit 1	Δ < 10 mV	OUTPUT connector, DC-voltmeter	open	
39	output level difference	a	~ /3 MHz, 20 MHz/10 Vpp	503, modulator unit 1	0 ± 0.3 dB	OUTPUT connector, power meter	50 Ohm	if the output level is too low, change capacitor 501 in the modulator to 27 pF; if the level is too high, increase resistor 714 PLL.
40	output level difference	c	~ /3 MHz, 20 MHz/10 Vpp	—	+ 0.1 ± 0.3 dB	OUTPUT connector, power meter	50 Ohm	
41	DC-level between T6 and T7	a	~ /5 MHz/10 Vpp	621, PLL unit 1	< 0.2 mV	T6, T7, DC-voltmeter	—	
SQUARE WAVE ADJUSTMENT								
42	positive half cycle	a	 /1 kHz/10 Vpp	603/pulse generator unit 1	Tx + 2 μs.	OUTPUT connector, Interval counter	50 Ohm	Tx = half cycle
43	positive half cycle: T	c (a)	 /1 kHz/10 Vpp	—	500 μs ≤ T ≤ 504 μs	OUTPUT connector, Interval counter	50 Ohm	if < 500 μs adjust with 603 to 500 μs; if > 504 μs check step 6 — DC adjustment
44	positive amplitude	a	 /0.05 Hz/10 Vpp	627/pulse generator unit 1	+ 4.95 ± 0.02 V	OUTPUT connector, DC voltmeter	open	
45	negative amplitude	a	 /0.05 Hz/10 Vpp	624/pulse generator unit 1	- 4.95 ± 0.02 V	OUTPUT connector, DC voltmeter	open	
46	rms-value	c	 /10 kHz/10 Vpp	—	2.5 ± 0.02 Vrms	OUTPUT connector, rms-voltmeter	50 Ohm	if this value is not correct, repeat 42 and 43
47	signalform	a	 /10 MHz/10 Vpp	505/modulator unit 1 (513/output amplif.)	adjust minimum rise-time without overshoot	OUTPUT connector, wide band oscilloscope (tr ≤ 1 nsec.)	50 Ohm	if 513 must be adjusted, the steps 39 and 40 PLL adjustment) are to be repeated
48	duty cycle	c (a)	 /20 MHz/20 Vpp	(614, pulse generator unit 1)	50 ± 5 %	OUTPUT connector, wide band oscilloscope (tr ≤ 1 nsec.)	50 Ohm	use potmeter 614 only in case of exceeded limits and adjust it until the limit is reached.

a = adjustment
c = check

Step	Objective		operation parameters settings	adjusting elements	measured value, value to be adjusted	test point, output measuring instruments	open output/50Ωterm.	comment	
49	rise-/falltime	c	□ /10 MHz/10 Vpp	—	< 10.5 nsec.	OUTPUT connector, wide band oscilloscope (tr ≤ 1nsec.)	50 Ohm		
50	aberrations (overshoot etc.)	c	□ /1 kHz/10 Vpp	—	< 2 %	OUTPUT connector, wide band oscilloscope (tr ≤ 1nsec.)	50 Ohm	aberrations related to the amplitude 0 – p.	
AM - AND FM-ADJUSTMENTS									
51	modulation frequency	a	~ /10 kHz/AM INT/50%/20 Vpp	699/modulator unit 1	1000 ± 0.1 Hz	MOD-OUT connector, counter	—		
52	distortion	a	~ /10 kHz/AM INT/50%/10 Vpp	700, 702/modulator unit	minimum distortion (< 0.5 %)	MOD-OUT connector, distortion meter	—		
53	DC-offset	a	~ /10 kHz/AM INT/50%/10 Vpp	709/modulator unit 1	+ 100 ± 50 mV	T21, DC-voltmeter	—		
54	residual FM	a	~ /5 MHz/FM EXT, MOD OFF/10 Vpp	620/PLL unit 1	minimum (< 500 Hz)	OUTPUT connector, modulation meter	50 Ohm	LF-band width 10 Hz – 20 kHz	
55	O-p frequency deviation (average)	a	~ /5, 10, 15, 20 MHz/FM INT/200 kHz DEV/10 Vpp	707/modulator unit 1	200 ± 3 kHz	OUTPUT connector, modulation meter	50 Ohm	± 3 kHz is the average failure over the whole range of 5 – 35 MHz, single failures can exceed these limits.	
56	AC-amplitude rms	a	~ /1 kHz/AM INT/0%/20 Vpp	684/modulator unit 1	1.767 ± 0.01 Vrms	OUTPUT connector, rms-voltmeter	50 Ohm		
57	modulation depth AM	a	~ /1 MHz/AM INT/50%/20 Vpp	686/modulator unit 1	50 ± 0.2 %	OUTPUT connector, modulation meter	50 Ohm	LF bandwidth 10 Hz – 20 kHz	
58	LF-suppression	a	~ /1 MHz/AM INT/50%/20 Vpp	663/modulator unit 1	minimum level	OUTPUT connector, rms-voltmeter with low pass filter	50 Ohm		
59	DC-difference	a	~ /5 kHz/AM INT/MOD OFF/0%/10 Vpp, 20 Vpp	681/modulator unit 1	< 1 ± 10 mV	OUTPUT connector, DC-voltmeter	open		
60	level difference	a	~ /1 MHz, 20 MHz/AM INT/0%/20 Vpp	511/modulator unit 1	-0.2 ± 1 dB	OUTPUT connector, power meter	50 Ohm		

a = adjustment
c = check

Step	Objective	operation parameters settings	adjusting elements	measured value, value to be adjusted	test point, output measuring instruments	open output/ 50Ω term.	comment
61	MISCELLANEOUS frequency response	~ /3 - 20 MHz/sweep lin cont/ Ts = 5 sec/0.001 Vpp	805/amplifier unit 1	0 ± 2 dB	OUTPUT connector, spectrum analyser	50 Ohm	start adjustment at full left position of 805 (bottom view) and turn it until frequency response is within ± 5 dB
62	frequency, level pp	~ /1 kHz/10 Vpp	—	8.589935 MHz ± 3 Hz level > 3.5 Vpp	INT CLOCK connector, counter, oscilloscope with 1 : 10 atten.	—	e. g. PM 6654 with 1 : 10 attenuator
63	frequency	~ /1 MHz/10 Vpp	—	1.164153 MHz ± 1 Hz	OUTPUT connector, counter	50 Ohm	connect external clock signal of 10 MHz ± 10 Hz to EXT CLOCK INPUT
64	frequency, level pp	~ /10 MHz/10 Vpp	—	10 MHz ± 3 Hz level > 3.5 Vpp	TTL out connector, counter, oscilloscope	—	
65	modulation depth	~ /10 MHz/AM EXT/10 Vpp	—	(50 ± 3.5) %	OUTPUT connector, modulation meter	50 Ohm	connect external signal - sine wave, 1 kHz, 1.4 Vpp to MOD INPUT (with 50 Ω)
66	gate function	~ /1 MHz/GATE INT/10 Vpp	—	check of the gate function	OUTPUT connector, oscilloscope	50 Ohm	
67	Mod out amplitude	~ /1 MHz/GATE INT/10 Vpp	—	sine wave 2.8 Vpp	MOD OUT connector, oscilloscope	—	
68	Pen lift amplitude	~ /fstart = 1 kHz/ fstop = 10 kHz/TS = 10 ms/ lin sweep cont/10 Vpp	—	square wave signal > 16 Vpp	PEN LIFT connector, oscilloscope	—	
69	Sweep out amplitude	~ /fstart = 1 kHz/ fstop = 10 kHz/TS = 100 ms/ lin sweep cont/10 Vpp	—	sawtooth signal 10 Vpp	SWEEP OUT connector, oscilloscope	—	

9. SAFETY INSPECTION AND TESTS AFTER REPAIR AND MAINTENANCE IN THE PRIMARY CIRCUIT

9.1. GENERAL DIRECTIVES

- Take care that creepage distances and clearances have not been reduced
- Before soldering, wires:
 - should be bent through the holes of solder tags, or wrapped round the tag in the form of an open U, or, wiring rigidity shall be maintained by cable clamps or cable lacing.
 - Replace all insulating guards and -plates.

9.2. SAFETY COMPONENTS

Components in the primary circuit may only be renewed by components selected by Philips, see also chapter 10.

9.3. CHECKING THE PROTECTIVE EARTH CONNECTION

The correct connection and condition is checked by visual control and by measuring the resistance between the protective-lead connection at the plug and the cabinet/frame. The resistance shall not be more than 0.5Ω . During measurement the mains cable should be moved. Resistance variations indicate a defect.

9.4. CHECKING THE INSULATION RESISTANCE

Measure the insulation resistance at $U = 500 \text{ Vdc}$ between the mains connections and the protective lead connections. For this purpose set the mains switch to ON. The insulation resistance shall not be less than $2 \text{ M}\Omega$.

Note:

$2 \text{ M}\Omega$ is a minimum requirement at 40° C and 95 % relative humidity. Under normal conditions the insulation resistance should be much higher (10 to $20 \text{ M}\Omega$).

9.5. TEST AFTER REPAIR AND MAINTENANCE

This part of the checking — and adjusting procedure represents the final check of the PM 5192. Bottom and top cover of the cabinet must be closed and the instrument must be warmed up for at least 2 hours. The check contains measurements of DC-levels, amplitudes and frequencies on following their specifications and furthermore some tests of modulation functions. The sequence of the measurements is free selectable.

9.5.1. Frequency Measurements

Objective	Frequency setting	maximum tolerance	connector
basic frequency	1 MHz	$\pm 0.8 \text{ Hz}$	OUTPUT
modulation frequency (1 kHz fixed)		$\pm 20 \text{ Hz}$	MOD OUT

9.5.2. Checking of the square wave and pulse signals (terminate output with 50 Ω)

Setting	Connector	Measuring Instrument
/10 MHz/10 Vpp	OUTPUT	wide band oscilloscope (tr ≤ 1nsec)

9.5.3. Modulation Measurements (terminate OUTPUT with 50 Ω)

Modulation	Carrier Frequency	Object	Measured tolerance	
OFF	4.05 MHz	} residual FM rms B _{lf} = 10 Hz – 20 kHz	} < 500 Hz	
"	8,589 MHz			
"	19 MHz			
FM EXT	4,05 MHz	} frequency deviation setting = 200 kHz (f _{mod} = 1 kHz)	} ± 30 kHz	
"	8,589 MHz			
"	19 MHz			
FM INT	5 MHz	} mod. depth setting 10 %	} ± 3 %	
"	10 MHz			–"– 50 %
"	15 MHz			–"– 90 %
AM INT	5 MHz		± 3 %	
"	5 MHz		± 3 %	
"	5 MHz		± 4 %	

9.5.4. DC-measurements

modulation off, frequency = 1 kHz

Waveform	Setting		DC-output open circuit	Tolerance of DC-output open circuit
	AC	DC		
AC OFF	0	0	0	± 30 mV
"	0	–10	–10	± 180 mV
"	0	– 5	– 5	± 105 mV
"	0	5	5	± 105 mV
"	0	10	10	± 180 mV
~	3,4 . . . , 20 Vpp	0	0	± 100 mV _{max}
	5, 10, 15, 20 Vpp	0	0	± 150 mV
~ 1 KHz/3 MHz	10 Vpp	0	0	± 100 mV, ΔU _{dc} < 25 mV
AM, frequency = 1 kHz				
~	10 Vpp	0	0	± 150 mV

9.5.5. AC-Measurements (terminate OUTPUT with 50 Ω)

Waveform	Frequency	Modulation	Setting Vpp	Tolerance
~	1 kHz	OFF	3.1	} $\pm 1.5\%$
"	"	"	3.2	
"	"	"	6.3	
"	"	"	6.4	
"	"	"	12.7	
"	"	"	12.8	
"	"	"	20.0	
"	"	"	0.30	$\pm 2.0\%$
"	"	"	1.00	"
"	"	"	2.00	"
"	"	"	0.003	$\pm 12.5\%$
"	"	"	0.010	$\pm 5.5\%$
"	"	"	0.020	$\pm 4.0\%$
"	"	"	0.050	$\pm 3.1\%$
"	"	"	0.100	$\pm 2.8\%$
"	"	"	0.200	$\pm 2.65\%$
~	"	"	10.0	$\pm 1.5\%$
□	"	"	10.0	$\pm 2.0\%$
∧	"	"	10.0	$\pm 2.5\%$
∨	"	"	10.0	$\pm 2.5\%$
~	1 kHz	AM INT 0 %	20.0	$\pm 2.0\%$
"	10 kHz	"	20.0	$\pm 2.0\%$
"	20 MHz	OFF	20.0	$\pm 4.0\%$
"	200 kHz	"	10.0	$\pm 1.5\%$
"	1.8 MHz	"	10.0	$\pm 2.5\%$
"	2.146 MHz	"	10.0	+ 0 / - 3.0 %
"	20 MHz	"	10.0	$\pm 4.0\%$
"	2.146 MHz	"	1.00	$\pm 3.5\%$
"	20 MHz	"	1.00	$\pm 6.0\%$
"	2.146 MHz	AM INT 0 %	20.0	$\pm 5.0\%$
"	20 MHz	" 0 %	20.0	$\pm 6.0\%$
"	2.146 MHz	OFF	0.100	$\pm 5.0\%$
"	20 MHz	"	0.100	+ 4.0 / - 8.5 %
"	2.146 MHz	"	0.010	+ 4.0 / - 10.0 %
"	20 MHz	"	0.010	+ 4.0 / - 12.0 %

10. SPARE PARTS

10.1. GENERAL

The synthesizer/function generator PM 5192 is repaired on single component level. No complete boards and modules are available at Concern Service Eindhoven.

Loaded PROMs must be ordered directly via Philips Supply Center Hamburg (please note software version).

In case of difficult faults central repair facility of the complete instrument is possible on special request via repair procedure at Supply Center Hamburg.

Conversion of an existing instrument to a different version is not foreseen.

Standard Parts

Electrical and mechanical parts replacement can be obtained through your local Philips organisation or representative. However, many of the standard electronic components can be obtained from other local suppliers. Before purchasing or ordering replacement parts, check the parts list for value, tolerance, rating and description.

NOTE: Physical size and shape of a component may affect instrument performance, particularly at high frequencies. Always use direct-replacement components, unless it is known that a substitute will not degrade instrument performance.

Special Parts

In addition to the standard electronic components, some special components are used:

- Components, manufactured or selected by Philips to meet specific performance requirements.
- Components which are important for the safety of the instrument marked with 'S' in the parts list.

ATTENTION: Both type of components may only be replaced by components obtained through your local Philips organisation.

10.2. STATIC SENSITIVE COMPONENTS

This instrument contains electrical components that are susceptible to damage from static discharge. Servicing static-sensitive assemblies or components should be performed only at a static-free work station by qualified service personnel.

10.3. HANDLING MOS DEVICES

Though all our MOS integrated circuits incorporate protection against electrostatic discharges, they can nevertheless be damaged by accidental over-voltages. In storing and handling them, the following precautions are recommended.

CAUTION: Testing or handling and mounting call for special attention to personal safety. Personnel handling MOS devices should normally be connected to ground via a resistor.

10.4. SOLDERING TECHNIQUES

Working method:

- Carefully unsolder one after the other the soldering tags of the semi-conductor.
- Remove all superfluous soldering material. Use a sucking iron or sucking litze wire.
- Check that the tags of the replacement part are clean and pre-tinned on the soldering places.
- Locate the replacement semi-conductor exactly on its place, and solder each tag to the relevant printed conductor on the circuit board.

NOTE: Bear in mind that the maximum permissible soldering time is 10 seconds during which the temperature of the tags must not exceed 250° C. The use of solder with a low melting point is therefore recommended.

Take care not to damage the plastic encapsulation of the semi-conductor (softening point of the plastic is 150° C).

ATTENTION: When you are soldering inside the instrument it is essential to use a low-voltage soldering iron, the tip of which must be earthed to ground of the instrument.

Suitable soldering irons should have temperature control and different types of nozzles (pin point tips), e. g. Weller Magnastat WTCP or WECP, Erska TC 70/24 V.

If a higher wattage-rating soldering iron is used on the etched circuit boards excessive heat can cause the etched circuit wiring to separate from the board base material.

In general use short-time heating with high tip temperature at a small point, avoid long time heating.

10.5. PARTS LIST PM 5192

10.5.1. Mechanical parts

Cabinet

Item	Quantity	Order number	Description
A	1	5322 447 91368	Top cover
B	1	5322 447 91369	Bottom cover
C	4	5322 462 40756	Plastic foot
D	4	5322 462 44434	Rubber foot, adhesive
E	4	5322 492 64745	Locking clip
F	1	5322 401 10867	Tilting support
G	1	5322 447 91373	Rear panel
H	2	5322 462 40761	Rear bumper
I	1	5322 447 91372	Front panel
J	1	5322 447 91371	Window for display
K	1	5322 456 90277	Text plate PM 5192
L	1	5322 447 90502	Front plate edging (upper)
M	1	5322 466 92117	Front plate edging (lower)
N	1	5322 460 60433	Profile ornament
O	1	5322 460 60452	Profile ornament with text
P	2	5322 447 90501	Side piece
P	2	5322 263 70186	Handle assembly (rack), not shown
Q	1	5322 460 60432	Profile orn. long, perf. (left)
R	1	5322 460 60434	Profile orn. short (right)
R	1	5322 460 60431	Profile orn. short, perf. (right)
S	1	5322 498 50176	Rubber handle
T	1	5322 462 40759	Steel insert

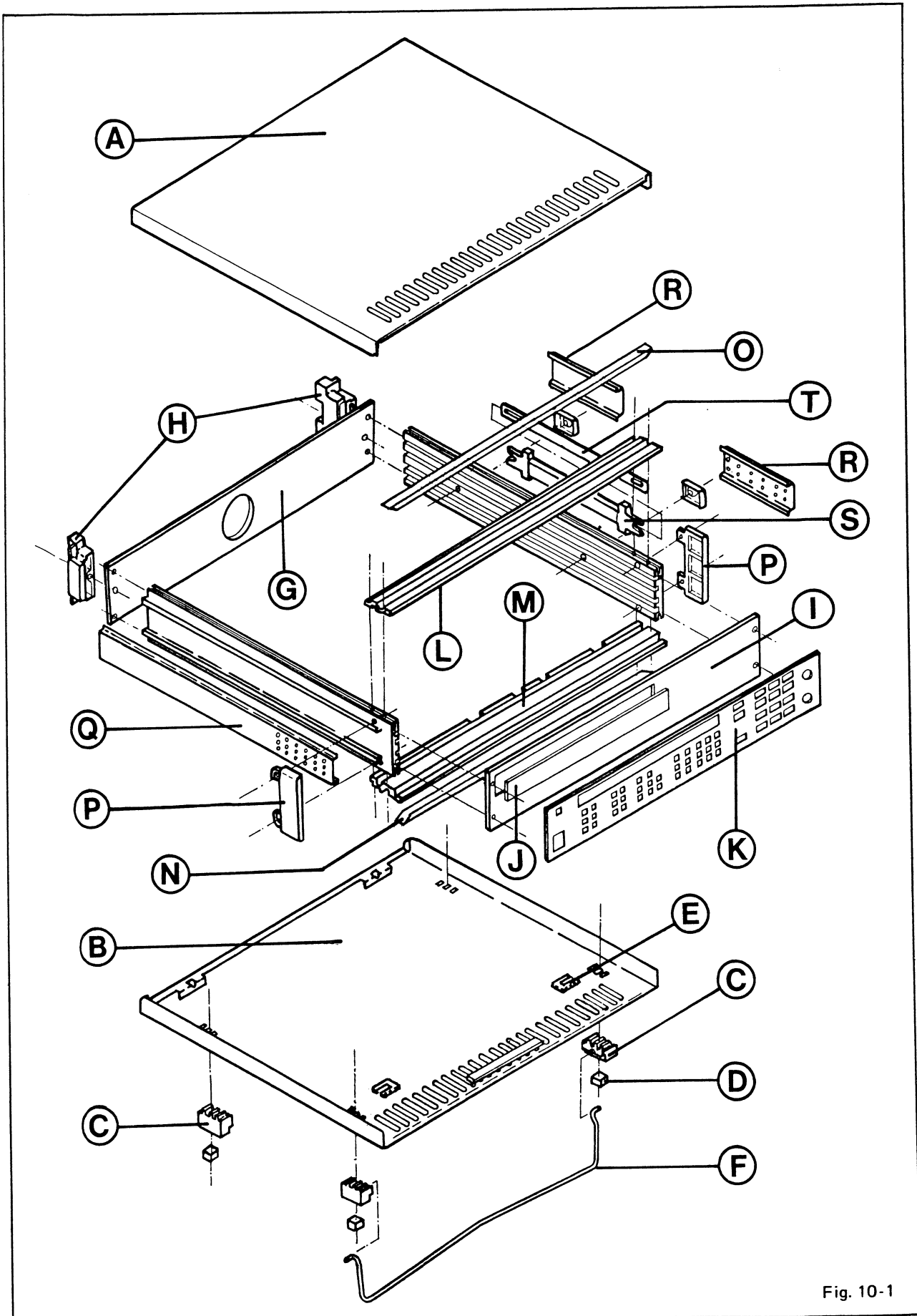

Fig. 10-1

10.5.2. Miscellaneous, parts not on units

Item	Fig.	Quantity	Order number	Description
880	33 (31)	1	5322 276 12029 *S	Mains switch
881, 882	33 (31)	2	5322 267 10004	BNC connector, front
862-867	33 (32)	6	5322 267 10173	BNC connector, rear
	33 (32)	1	5322 321 22352	IEEE connector wired
870	33 (32)	1	5322 267 30416 *S	Mains socket with filter
	10-2	1	5322 321 10388 *S	Mains cable (Europe)
	10-3	1	5322 321 20816 *S	Mains cable (USA)
	10-4	1	5322 321 10123 *S	Mains cable (U. K.)
	32	1	5322 267 10173 *S	Fuse holder
869	33 (32)	1	4822 253 30018 *S	Fuse 630 mAT
869	33 (32)	1	4822 253 30022 *S	Fuse 1.25 AT
869	33 (32)	1	4822 253 30024 *S	Fuse 1.6 AT
868	33	1	5322 361 10451 *S	Fan
751	33	1	5322 146 21241 *S	Transformer
	31	15	5322 414 60037	Knob, large 12.5 x 6.5
	31	7	5322 414 60036	Knob, small 6.5 x 6.5
	31	29	5322 414 60038	Knob, small with LED
881, 882	33	2	5322 116 21068	Varistor (BNC front)
852-857	33	6	5322 116 21137	Varistor (BNC rear)
850-858	33	9	5322 526 14034	Damping bead (BNC connector)
	32	1	5322 462 44172	Cap for IC (rear panel)

*S = Safety component, see chapter 10.1.

Mains cables

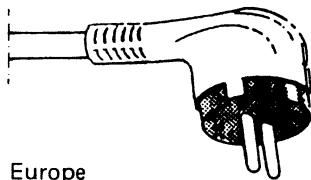

Europe

Fig. 10-2

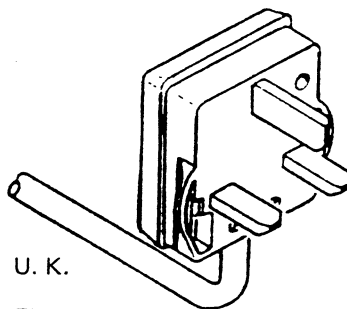

U. K.

Fig. 10-3

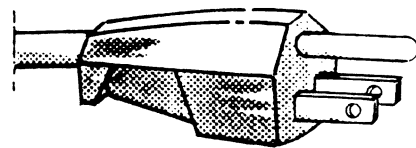

U S A

Fig. 10-4

10.5.3. Electrical Parts

Some parts are listed in chapter 10.5.2.

All metal film resistors not listed are of type MR 25 ± 1 % 0.4 W (ordering code see end of this list).

*1 Please order loaded PROM directly via Philips Supply Center Hamburg (note software version).

Pos. no.	Description				Ordering code
UNIT 1, POWER SUPPLY					
INTEGRATED CIRCUITS / UNIT 1, POWER SUPPLY					
301, 303	Integr. circuit	Regulator 78GCU1			5322 209 85565
302, 304	Integr. circuit	Regulator 79GCU1			5322 209 86349
305	Integr. circuit	Regulator LM223K			5322 209 71639 (rear wall)
TRANSISTORS / UNIT 1, POWER SUPPLY					
351	Transistor	BD204			5322 130 44324
352	Transistor	BD203			5322 130 44325
360	Transistor	BC558B			4822 130 44197
DIODES / UNIT 1, POWER SUPPLY					
401	Rectifier	SKB2/08L5A			5322 130 32031
402-405	Diode, reference	BZX92			5322 130 34397
417	Diode, reference	BZX75C1V4			4822 130 34047
420, 421	Rectifier	BY260-200			4822 130 32145 (rear wall)
CAPACITORS / UNIT 1, POWER SUPPLY					
501, 503	Cap. foil	220 nF	20 %	100 V	4822 121 40232
502, 504	Cap. electrolyt.	10 000 µF		40 V	5322 124 41278
505, 506	Cap. solid alu.	1 µF		25 V	4822 124 20944
508-510	Cap. foil	220 nF	20 %	100 V	4822 121 40232
511-513	Cap. electrolyt.	4 700 µF		25 V	5322 124 21459
512	Cap foil	220 nF	20 %	100 V	4822 121 40232
514, 515	Cap. solid alu.	1 µF		25 V	4822 124 20944
516	Cap. foil	220 nF	20 %	100 V	4822 121 40232
517	Cap. electrolyt.	22 000 µF		16 V	5322 124 70435
518	Cap. solid alu.	1 µF		25 V	4822 124 20944
519	Cap. ceramic	100 nF	10 %	50 V	5322 122 32941
520	Cap. solid alu.	2.2 µF		25 V	4822 124 21255
521-523	Cap. ceramic	100 nF	10 %	50 V	5322 122 32941
524, 525	Cap. solid alu.	2.2 µF		40 V	5322 124 14014
526	Cap. electrolyt.	47 µF		63 V	4822 124 40433
527	Cap. ceramic	100 nF	10 %	50 V	5322 122 32941
528	Cap. solid alu.	22 µF		10 V	4822 124 20943

Pos. no.	Description					Ordering code
----------	-------------	--	--	--	--	---------------

RESISTORS / UNIT 1, POWER SUPPLY

602	Res. metal film	5.6 Ω	5 %	2.5 W	4822 116 52165
604, 609	Potm. trimmer	220 Ω	CERMET	0.1 W	4822 100 10359
607	Res. metal film	5.6 Ω	5 %	2.5 W	4822 116 52165
612	Potm. trimmer	470 Ω	CERMET	0.1 W	5322 101 14047
615	Potm. trimmer	220 Ω	CERMET	0.1 W	4822 100 10359

COIL / UNIT 1, POWER SUPPLY

800	Coil				5322 158 10271
-----	------	--	--	--	----------------

UNIT 1, AMPLIFIER

INTEGRATED CIRCUITS / UNIT 1, AMPL.

301	Integr. circuit	MC1558U			5322 209 71645
302	Integr. circuit	HEF4094BP			5322 209 10421
303	Integr. circuit	SE538N			5322 209 71641
304, 305	Integr. circuit	TL071IP			5322 209 71643
306	Integr. circuit	HEF4094BP			5322 209 10421
307	Integr. circuit	DAC-08EN			5322 209 11254
308	Integr. circuit	TL072IP			5322 209 71646
312	Integr. circuit	HEF4094BP			5322 209 10421
313	Integr. circuit	7406N-00			5322 209 86327
314, 315	Integr. circuit	HEF4066BP			5322 209 10357

TRANSISTORS / UNIT 1, AMPL.

320, 321	Transistor	BC548B			4822 130 40937
330, 332	Transistor	BFW16A			5322 130 44015
331	Transistor	2N4035			5322 130 44201
333	Transistor	BF450			4822 130 44237
334, 335	Transistor	BC558B			4822 130 44197
336	Transistor	BF240			4822 130 40902
337	Transistor	BF450			4822 130 44237
338	Transistor	BC548B			4822 130 40937
339	Transistor	BC558B			4822 130 44197
340	Transistor	BF240			4822 130 40902
341	Transistor	BF450			4822 130 44237
343	Transistor	BC558B			4822 130 44197
344	Transistor	BF240			4822 130 40902
345	Transistor	BF450			4822 130 44237
347	Transistor	BC558B			4822 130 44197
348	Transistor	BF240			4822 130 40902
349	Transistor	BF450			4822 130 44237
351	Transistor	BC558B			4822 130 44197
352	Transistor	BF240			4822 130 40902
353	Transistor	BF450			4822 130 44237

Pos. no.	Description		Ordering code
355	Transistor	BC558B	4822 130 44197
356	Transistor	BF240	4822 130 40902
357	Transistor	BF450	4822 130 44237
359	Transistor	BC558B	4822 130 44197
360	Transistor	BF240	4822 130 40902
361	Transistor	BF450	4822 130 44237
363	Transistor	BC558B	4822 130 44197
364	Transistor	BF240	4822 130 40902
365	Transistor	BSX20	4822 130 41705
366	Transistor	BC558B	4822 130 44197
367	Transistor	BC548B	4822 130 40937
368	Transistor	2N2894A	5322 130 44127
369	Transistor	BC558C	5322 130 60068
370	Transistor	2N4035	5322 130 44201
371	Transistor	BC548B	4822 130 40937
372	Transistor	BSX20	4822 130 41705
373	Transistor	BC558B	4822 130 44197
374	Transistor	BC548C	4822 130 44196
375	Transistor	2N4035	5322 130 44201
376	Transistor	BFW16A	5322 130 44015
377	Transistor	BC548B	4822 130 40937
378	Transistor	BSX20	4822 130 41705
379, 380	Transistor	BFW16A	5322 130 44015
381	Transistor	2N2894A	5322 130 44127
382, 383	Transistor	2N5583	5322 130 44033
384	Transistor	BSS61	5322 130 44714
385-387	Transistor	2N5583	5322 130 44033
388	Transistor	2N2905A	5322 130 40468
389	Transistor	2N2219A	5322 130 44034
390-392	Transistor	BFW16A	5322 130 44015
393	Transistor	BSS52	5322 130 44579
394, 395	Transistor	2N2905A	5322 130 40468
396	Transistor	BF450	4822 130 44237
397, 398	Transistor	2N2219A	5322 130 44034
399	Transistor	BF240	4822 130 40902
DIODES / UNIT 1, AMPL.			
403, 404	Diode, ref.	BZV46C1V5	5322 130 34865
405, 406	Diode	BAW62	4822 130 30613
409, 411	Diode, ref.	BZV46C1V5	5322 130 34865
416, 417	Diode, ref.	BZX79C6V8	4822 130 34278
419, 420	Diode, ref.	BZX79C5V1	4822 130 34233
421, 422	Diode, ref.	BZX79C6V2	4822 130 34167
423	Diode, ref.	BZX90	5322 130 34397
424-439	Diode	BA482 (selected)	5322 130 80265
440, 441	Diode, ref.	BZV46C1V5	5322 130 34865
442	Diode, ref.	BZX90	5322 130 34397

Pos. no.	Description				Ordering code
CAPACITORS / UNIT 1, AMPL.					
501	Cap. ceramic	10 nF	+ 20/- 90 %	40 V	4822 122 30043
502	Cap. ceramic	1 nF	10 %	100 V	5322 122 32331
503	Cap. ceramic	2.2 pF	0.25 %	100 V	4822 122 31036
504, 506	Cap. ceramic	100 nF	10 %	50 V	5322 122 32941
505, 507	Cap. electrolyt.	220 μ F		16 V	4822 124 40196
508-511	Cap. ceramic	100 nF	10 %	50 V	5322 122 32941
512	Cap. ceramic	39 pF	2 %	100 V	4822 122 31069
513	Cap. trimmer	5.5-65 pF		100 V	5322 125 54025
514	Cap. solid alu.	10 μ F		16 V	4822 124 21314
515	Cap. ceramic	10 nF	+ 20/- 90 %	40 V	4822 122 30043
516	Cap. ceramic	100 nF	10 %	50 V	5322 122 32941
517-520	Cap. ceramic	10 nF	+ 20/- 90 %	40 V	4822 122 30043
521	Cap. ceramic	100 nF	10 %	50 V	5322 122 32941
522	Cap. solid alu.	10 μ F		16 V	4822 124 21314
523	Cap. ceramic	10 nF	+ 20/- 90 %	40 V	4822 122 30043
525	Cap. ceramic	100 nF	10 %	50 V	5322 122 32941
526	Cap. ceramic	100 pF	2 %	100 V	4822 122 31316
528-531	Cap. ceramic	100 nF	10 %	50 V	5322 122 32941
532, 533	Cap. ceramic	470 pF	2 %	63 V	4822 122 32062
534	Cap. ceramic	100 nF	10 %	50 V	5322 122 32941
536, 537	Cap. solid alu.	10 μ F		16 V	4822 124 21314
538	Cap. ceramic	4.7 nF	10 %	100 V	4822 122 31125
539	Cap. ceramic	150 pF	2 %	100 V	4822 122 31413
540, 542	Cap. ceramic	68 pF	2 %	100 V	4822 122 31349
544	Cap. ceramic	100 nF	10 %	50 V	5322 122 32941
545	Cap. solid alu.	1 μ F		25 V	4822 124 20944
547	Cap. ceramic	10 nF	+ 20/- 90 %	40 V	4822 122 30043
548	Cap. ceramic	100 nF	10 %	50 V	5322 122 32941
549, 550	Cap. ceramic	10 nF	+ 20/- 90 %	40 V	4822 122 30043
551, 553	Cap. ceramic	100 nF	10 %	50 V	5322 122 32941
554	Cap. solid alu.	1 μ F		25 V	4822 124 20944
555	Cap. ceramic	10 nF	+ 20/- 90 %	40 V	4822 122 30043
557	Cap. ceramic	15 pF	2 %	100 V	4822 122 31823
560, 561	Cap. ceramic	100 nF	10 %	50 V	5322 122 32941
562-565	Cap. ceramic	10 nF	+ 20/- 90 %	40 V	4822 122 30043
566-574	Cap. ceramic	100 nF	10 %	50 V	5322 122 32941
577, 578	Cap. ceramic	220 pF	2 %	100 V	5322 122 34047
581, 582	Cap. ceramic	470 nF	20 %	100 V	5322 122 33078
583	Cap. ceramic	1 nF	10 %	100 V	4822 122 30027

Pos. no.	Description					Ordering code
RESISTORS / UNIT 1, AMPL.						
609, 610	Res. metal film	312 Ω	0.1 %	0.25 W		5322 116 80206
611, 612	Res. metal film	412 Ω	0.1 %	0.25 W		5322 116 80211
613, 614	Res. metal film	825 Ω	0.1 %	0.25 W		5322 116 80213
644, 653	Res. network	8 x 4.7 k Ω	5 %	0.125 W		5322 116 90132
666	Potm. trimmer	100 Ω	carb.	0.1 W		4822 100 10075
700	Potm. trimmer	2.2 k Ω	carb.	0.1 W		4822 100 10029
702	Res. metal film	130 Ω	5 %	1.6 W		5322 116 55509
769	Potm. trimmer	1 k Ω	carb.	0.1 W		4822 100 10037
771	Potm. trimmer	4.7 k Ω	carb.	0.1 W		4822 100 10036
787	Res. metal film	100 Ω	0.1 %	0.25 W		5322 116 80208
788	Res. metal film	150 Ω	0.1 %	0.25 W		5322 116 80209
789	Res. metal film	261 Ω	0.1 %	0.25 W		5322 116 80205
792, 793	Res. metal film	100 Ω	0.1 %	0.25 W		5322 116 80208
794	Res. metal film	150 Ω	0.1 %	0.25 W		5322 116 80209
795	Res. metal film	261 Ω	0.1 %	0.25 W		5322 116 80205
805	Potm. trimmer	2.2 k Ω	carb.	0.1 W		4822 100 10029
809	Potm. trimmer	10 k Ω	carb.	0.1 W		4822 100 10035
825-828	Res. metal film	39 Ω	5 %	0.5 W		4822 116 52193
874	Potm. trimmer	470 Ω	carb.	0.1 W		4822 100 10038
COILS / UNIT 1, AMPL.						
831, 832	Wide band choke					5322 158 10271
833, 835	Choke	220 μ H				5322 157 53012
838	Wide band choke					5322 157 53015
873	Choke	220 μ H				5322 157 53012
RELAIS / UNIT 1, AMPL.						
841-848	Reed relais	5 V				5322 280 20281

Pos. no.	Description		Ordering code
UNIT 1, MODULATOR			
INTEGRATED CIRCUITS / UNIT 1, MOD.			
301	Integr. circuit	HEF4053BP	5322 209 10576
302	Integr. circuit	HEF4094BP	5322 209 10421
303	Integr. circuit	N74LS02N	5322 209 85312
304	Integr. circuit	N74LS27N	5322 209 85561
305	Integr. circuit	MC1495L	5322 209 71638
306	Integr. circuit	NE538N	5322 209 81343
309	Integr. circuit	TL072ACP-00	5322 209 71644
310	Integr. circuit	XR-2206CP	5322 209 86453
311	Integr. circuit	AD7523JN	5322 209 70195
313, 316	Integr. circuit	HEF4094BP	5322 209 10421
314, 315	Integr. circuit	HEF4053BP	5322 209 10576
317	Integr. circuit	HEF4001BP	4822 209 10246

TRANSISTORS / UNIT 1, MOD.

350	Transistor	BC558B	4822 130 44197
352-355	Transistor	BC548B	4822 130 40937
358	Transistor	BSX20	4822 130 41705
359	Transistor	2N2894A	5322 130 44127
360, 361	Transistor	BSX20	4822 130 41705
362	Transistor	BC548B	4822 130 40937
363	Transistor	BC558B	4822 130 44197
364, 365	Transistor	2N2894A	5322 130 44127
366, 367	Transistor	BSX20	4822 130 41705
378, 379	Transistor	BF450	4822 130 44237
380, 381	Transistor	BF240	4822 130 40902
382	Transistor	BC548B	4822 130 40937
383	Transistor	BC558B	4822 130 44197

Pos. no.	Description				Ordering code
DIODES / UNIT 1, MOD.					
401, 402	Diode, ref.	BZX79B4V7			4822 130 34174
403-408	Diode, ref.	BZX79B6V8			4822 130 34278
410-418	Diode	BA481			5322 130 32239
421	Diode, ref.	BZX79C8V2			4822 130 34382
422, 423	Diode, ref.	BZX79C6V8			4822 130 34278
426	Diode	BAW62			4822 130 30613
427, 428	Diode, ref.	BZX79B4V7			4822 130 34174
429, 430	Diode, ref.	BZX79B4V3			4822 130 31554
431	Diode, ref.	BZX79B10			4822 130 34297
432, 433	Diode	BA481			5322 130 32239
CAPACITORS / UNIT 1, MOD.					
503	Cap. trimmer	2-22 pF		100 V	4822 125 50045
504	Cap. ceramic	100 nF	10 %	50 V	5322 122 32941
505, 511	Cap. trimmer	2-22 pF		100 V	4822 125 50045
513	Cap. ceramic	120 pF	2 %	100 V	4822 122 31685
514-516	Cap. ceramic	100 nF	10 %	20 V	5322 122 30108
517	Cap. ceramic	270 pF	2 %	100 V	4822 122 30107
519	Cap. ceramic	220 pF	2 %	100 V	5322 122 34047
521	Cap. ceramic	100 nF	10 %	50 V	5322 122 32941
522	Cap. solid alu.	15 μ F		16 V	4822 124 20977
523	Cap. solid alu.	1 μ F		25 V	4822 124 20944
528	Cap. ceramic	100 nF	10 %	50 V	5322 122 32941
529	Cap. solid alu.	15 μ F		16 V	4822 124 20977
532	Cap. foil	33 nF	1 %	63 V	5322 121 54111
534	Cap. ceramic	100 nF	10 %	50 V	5322 122 32941
535	Cap. trimmer	5.5-65 pF		100 V	5322 125 54025
536	Cap. ceramic	33 pF	2 %	100 V	5322 122 32072
537	Cap. electrolyt.	47 μ F		25 V	4822 124 22027
540-544	Cap. ceramic	100 nF	10 %	100 V	5322 122 32941
545-546	Cap. ceramic	100 pF	2 %	100 V	4822 122 31316
547	Cap. ceramic	22 pF	2 %	100 V	5322 122 32143
548-549	Cap. ceramic	82 pF	2 %	100 V	4822 122 31237
550	Cap. ceramic	2.2 nF	10 %	100 V	4822 122 30114

Pos. no.	Description				Ordering code
RESISTORS / UNIT 1, MOD.					
601	Res. metal film	1 k Ω	0.1 %	0.25 W	5322 116 52384
602, 607	Potm. trimmer	47 k Ω	CERMET	0.5 W	5322 101 10509
604, 606	Res. metal film	2 k Ω	0.1 %	0.25 W	5322 116 51812
609, 611	Res. metal film	2 k Ω	0.1 %	0.25 W	5322 116 51812
613	Potm. trimmer	470 Ω	CERMET	0.5 W	5322 101 14047
624, 627	Potm. trimmer	100 Ω	CERMET	0.5 W	5322 101 14011
663, 681	Potm. trimmer	10 k Ω	carb.	0.1 W	4822 100 10035
684	Potm. trimmer	2.2 k Ω	carb.	0.1 W	4822 100 10029
686	Potm. trimmer	470 Ω	carb.	0.1 W	4822 100 10038
696	Potm. trimmer	1 k Ω	CERMET	0.5 W	4822 100 10254
699	Potm. trimmer	10 k Ω	carb.	0.1 W	4822 100 10035
700	Potm. trimmer	220 Ω	carb.	0.1 W	4822 100 10019
702, 709	Potm. trimmer	22 k Ω	carb.	0.1 W	4822 100 10051
707	Potm. trimmer	1 k Ω	carb.	0.1 W	4822 100 10037
714	Res. N. T. C.	4.7 k Ω	10 %	0.25 W	5322 116 30215
COILS / UNIT 1, MOD.					
801	Choke	0.33 μ H			5322 157 53013
802	Choke	220 μ H			5322 157 53012
RELAIS / UNIT 1, MOD.					
810-812	Reed relais	5 V			5322 280 20281

Pos. no.	Description				Ordering code
UNIT 1, PULSE GENERATOR					
INTEGRATED CIRCUITS / UNIT 1, PULSE GEN.					
301	Integr. circuit	NE521N			5322 209 14441
302	Integr. circuit	N74LS86N			5322 209 84997
303	Integr. circuit	N74S258N			5322 209 85674
305	Integr. circuit	N74S00N			5322 209 84167
TRANSISTORS / UNIT 1, PULSE GEN.					
351	Transistor	BC548B			4822 130 40937
352, 354	Transistor	2N2894A			5322 130 44127
353, 355	Transistor	BSX20			4822 130 41705
356, 357	Transistor	2N2894A			5322 130 44127
358	Transistor	2N5583			5322 130 44033
DIODES / UNIT 1, PULSE GEN.					
401, 402	Diode, ref.	BZX79B4V7			4822 130 34174
403	Diode, ref.	BZV46C2V0			4822 130 31248
404	Diode, ref.	BZX79B6V2			4822 130 34167
405-408	Diode	BA481			5322 130 32239
409, 410	Diode, ref.	BZX75C2V8			4822 130 34048
411	Diode, ref.	BZX79B4V7			4822 130 34174
412, 413	Diode	BA481			5322 130 32239
414	Diode, ref.	BZX79B3V3			5322 130 31504
428	Diode	BAW62			4822 130 30613
CAPACITORS / UNIT 1, PULSE GEN.					
501, 502	Cap. ceramic	10 nF	+ 50/- 20 %	100 V	4822 122 31414
503	Cap. ceramic	220 pF	2 %	100 V	5322 122 34047
504, 505	Cap. ceramic	100 nF	10 %	50 V	5322 122 32941
506, 507	Cap. ceramic	10 nF	+ 50/- 20 %	100 V	4822 122 31414
508, 509	Cap. ceramic	100 nF	10 %	50 V	5322 122 32941
510, 511	Cap. ceramic	10 nF	+ 50/- 20 %	100 V	4822 122 31414
512-517	Cap. ceramic	100 nF	10 %	50 V	5322 122 32941
518, 519	Cap. solid alu.	10 μ F		16 V	4822 124 21314
520	Cap. ceramic	100 nF	10 %	50 V	5322 122 32941
541	Cap. ceramic	10 nF	+ 50/- 20 %	100 V	4822 122 31414
RESISTORS / UNIT 1, PULSE GEN.					
603	Potm. trimmer	100 k Ω	carb.	0.1 W	4822 100 10052
614	Potm. trimmer	4.7 k Ω	carb.	0.1 W	4822 100 10036
624, 627	Potm. trimmer	4.7 k Ω	carb.	0.1 W	4822 100 10036
650	Res. metal film	150 Ω	5 %	1.6 W	4822 116 51142
COILS / UNIT 1, PULSE GEN.					
806	Choke	22 μ H			5322 157 50317

Pos. no.	Description		Ordering code
----------	-------------	--	---------------

UNIT 1, PLL / VCO

INTEGRATED CIRCUITS / UNIT 1, PLL / VCO

301	Integr. circuit	HEF4094BP	5322 209 10421
302	Integr. circuit	DAC-08EN	5322 209 11254
303, 312	Integr. circuit	LF356N	5322 209 86451
304, 307	Integr. circuit	LF256H	5322 209 71642
306	Integr. circuit	TL072IP	5322 209 71646
309	Integr. circuit	MC4044P	5322 209 85821
311	Integr. circuit	MC1456P1	5322 209 71647
313	Integr. circuit	HEF4053BP	5322 209 10576
314	Integr. circuit	N74S00N	5322 209 84167
316	Integr. circuit	SN74197N	5322 209 84516
317	Integr. circuit	N74LS393N	4822 209 80447
318	Integr. circuit	N74LS00N	5322 209 84823
320	Integr. circuit	MC3346P (CA3086)	5322 209 84111

TRANSISTORS / UNIT 1, PLL / VCO

351, 354	Transistor	BC548B	4822 130 40937
352, 353	Transistor	BC558B	4822 130 44197
356	Transistor	BF450	4822 130 44237
357, 358	Transistor	2N4035	5322 130 44201
359	Transistor	BF240	4822 130 40902
361	Transistor	BSV79	5322 130 44017
362	Transistor	BFX89	5322 130 40542
363	Transistor	BFW16A	5322 130 44015
364, 366	Transistor	BFX89	5322 130 40542
367, 368	Transistor	2N2894A	5322 130 44127
369, 371	Transistor	PH2369	4822 130 41594
372	Transistor	BC548B	4822 130 40937
373	Transistor	BC558B	4822 130 44197
374, 376	Transistor	2N4035	5322 130 44201
375, 377	Transistor	BF240	4822 130 40902
378	Transistor	2N4035	5322 130 44201
379	Transistor	BF450	4822 130 44237
380	Transistor	BF240	4822 130 40902
381	Transistor	BC558B	4822 130 44197
382	Integr. circuit	Regul. UA7815UC	4822 209 80808

DIODES / UNIT 1, PLL / VCO

401, 402	Diode, ref.	BZX79C4V7	4822 130 34174
403	Diode, ref.	BZX91	5322 130 34397
404-407	Diode, ref.	BZX79C4V7	4822 130 34174
408	Diode, ref.	BZX79C4V3	4822 130 31554
409, 411	Diode, ref.	BZX79C5V1	4822 130 34233
412	Diode, ref.	BZX91	5322 130 34397
413, 417	Diode, ref.	BZX79C4V7	4822 130 34174
414, 420	Diode	BAW62	4822 130 30613
416	Diode, ref.	BZX79C6V2	4822 130 34167
418	Diode, ref.	BZV46C1V5	5322 130 34865
419	Diode, ref.	BZX79B3V3	5322 130 31504

Pos. no.	Description				Ordering code
CAPACITORS / UNIT 1, PLL / VCO					
502	Cap. ceramic	10 nF	+ 50/- 20 %	100 V	4822 122 31414
503	Cap. solid alu.	10 μ F		16 V	4822 124 21314
504-506	Cap. ceramic	100 nF	10 %	20 V	5322 122 30108
507, 508	Cap. ceramic	100 nF	10 %	50 V	5322 122 32941
509	Cap. ceramic	33 pF	2 %	100 V	5322 122 32072
511	Cap. ceramic	220 pF	2 %	100 V	5322 122 34047
512	Cap. ceramic	100 nF	10 %	20 V	5322 122 30108
513, 514	Cap. tantal	47 μ F		6.3 V	4822 124 10197
516	Cap. foil	4.7 nF	5 %	63 V	4822 121 50539
517	Cap. ceramic	470 pF	2 %	63 V	4822 122 32062
518, 519	Cap. ceramic	100 nF	10 %	50 V	5322 122 32941
521, 522	Cap. electrolyt.	100 μ F		25 V	4822 124 40207
523, 524	Cap. ceramic	4.7 nF	10 %	100 V	4822 122 31125
526	Cap. trimmer	2-10 pF		100 V	4822 125 50062
527	Cap. ceramic	56 pF	2 %	100 V	4822 122 32027
529	Cap. ceramic	4.7 nF	10 %	100 V	4822 122 31125
533, 547	Cap. ceramic	10 nF	+ 50/- 20 %	100 V	4822 122 31414
536	Cap. trimmer	2-22 pF		100 V	4822 125 50045
537	Cap. ceramic	68 pF	2 %	100 V	4822 122 31349
539	Cap. ceramic	100 nF	10 %	20 V	5322 122 30108
541	Cap. ceramic	470 pF	2 %	63 V	4822 122 32062
542	Cap. ceramic	100 nF	10 %	20 V	5322 122 30108
544	Cap. ceramic	2.2 nF	10 %	100 V	4822 122 30114
548-552	Cap. ceramic	100 nF	10 %	50 V	5322 122 32941
556	Cap. tantal	47 μ F		6.3 V	5322 124 10197
557, 566	Cap. ceramic	100 nF	10 %	50 V	5322 122 32941
558	Cap. solid alu.	10 μ F		16 V	4822 124 21314
559-562	Cap. ceramic	10 nF	+ 50/- 20 %	100 V	4822 122 31414
563	Cap. ceramic	27 pF	2 %	100 V	4822 122 30045
564-565	Cap. ceramic	10 nF	+ 50/- 20 %	100 V	4822 122 31414
568, 569	Cap. ceramic	100 nF	10 %	20 V	5322 122 30108
570	Cap. ceramic	220 pF	2 %	100 V	5322 122 34047
571	Cap. ceramic	100 nF	10 %	20 V	5322 122 30108
572	Cap. ceramic	10 nF	+ 50/- 20 %	100 V	4822 122 31414
573, 574	Cap. ceramic	100 nF	10 %	50 V	5322 122 32941
RESISTORS / UNIT 1, PLL / VCO					
611	Potm. trimmer	470 Ω	carb.	0.1 W	4822 100 10038
614, 621	Potm. trimmer	10 k Ω	carb.	0.1 W	4822 100 10035
620	Potm. trimmer	22 k Ω	carb.	0.1 W	4822 100 10051
625	Resistor	10 M Ω	5 %	0.25 W	4822 110 72214
636	Potm. trimmer	220 Ω	carb.	0.1 W	4822 100 10019
650, 655	Res. metal film	39 Ω	5 %	0.5 W	4822 116 52193
684	Potm. trimmer	100 Ω	carb.	0.1 W	4822 100 10075
706, 709	Potm. trimmer	22 k Ω	carb.	0.1 W	4822 100 10051
721	Potm. trimmer	47 Ω	carb.	0.1 W	4822 100 10476
COILS / UNIT 1, PLL / VCO					
801-803	Damping lead	FXC3B			5322 526 10366
805	Damping lead	FXC3B			5322 526 10366
804, 807	Coil	4.7 μ H			5322 158 10628
808	Coil	15 μ H			5322 158 14004

Pos. no.	Description		Ordering code
UNIT 2, CPU			
INTEGRATED CIRCUITS / UNIT 2, CPU			
301-304	Integr. circuit	MC3441AP	5322 209 85464
305	Integr. circuit	HEF4093BP	5322 209 14927
306	Integr. circuit	HEF4738VP	5322 209 14509
307	Integr. circuit	HEF40244BP	5322 209 10489
308	Integr. circuit	HEF40373BP	5322 209 10491
309, 310	Integr. circuit	HEF4014BP	4822 209 10296
311	Integr. circuit	HEF4094BP	5322 209 10421
312	Integr. circuit	HEF4514BP	5322 209 14051
313	Integr. circuit	N74LS175N	5322 209 84999
314	Integr. circuit	N74LS363N	5322 209 81776
315*1	I. C. P27128	(PROM, software version)	
317	Integr. circuit	PC74HCU04P	5322 209 11323
318	Integr. circuit	P8031U processor	5322 209 82034
319	Integr. circuit	N74LS390N	5322 209 86362
320	Integr. circuit	HEF4049BP	4822 209 10306
321	Integr. circuit	HEF4094BP	5322 209 10421
322	Integr. circuit	LM741CN	4822 209 80617
323	Integr. circuit	DAC-08EN	5322 209 11254
324, 325	Integr. circuit	PCD8571P DIL8	4822 209 83571
TRANSISTOR / UNIT 2, CPU			
351	Transistor	BC337-16	4822 130 41095
DIODE / UNIT 2, CPU			
401-404	Diode	BAW62	4822 130 30613
CAPACITORS / UNIT 2, CPU			
501	Cap. solid alu.	3.3 μ F	16 V 4822 124 20947
502	Cap. ceramic	220 pF 10 %	100 V 4822 122 30094
503, 505	Cap. ceramic	22 pF 2 %	100 V 5322 122 32143
504	Cap. ceramic	27 pF 2 %	100 V 4822 122 30045
506-511	Cap. ceramic	22 nF +20/-90 %	40 V 4822 122 30103
512	Cap. electrolyt.	220 μ F	16 V 4822 124 40196
513-515	Cap. ceramic	22 nF +20/-90 %	40 V 4822 122 30103
517	Cap. ceramic	100 nF 10 %	50 V 5322 122 32941

Pos. no.	Description				Ordering code
RESISTORS / UNIT 2, CPU					
601, 602	Res. network	8 x 4.7 k Ω	5 %	0.125 W	5322 116 90132
604, 605	Res. network	8 x 4.7 k Ω	5 %	0.125 W	5322 116 90132
609	Res. network	8 x 4.7 k Ω	5 %	0.125 W	5322 116 90132
CRYSTAL / UNIT 2, CPU					
801	Crystal	10 MHz			5322 242 71724
MISCELLANEOUS / UNIT 2, CPU					
802	Lithium cell	3V/160mAh			5322 138 10144

Pos. no.	Description		Ordering code
UNIT 2, DFS			
INTEGRATED CIRCUITS / UNIT 2, DFS			
301	Integr. circuit	PC74HCU04P	5322 209 11323
302, 306	Integr. circuit	N74LS132N	5322 209 85201
303	Integr. circuit	SN74LS109AN	5322 209 85974
304, 305	Integr. circuit	N74LS02N	5322 209 85312
307-311	Integr. circuit	HEF4094BP	5322 209 10421
312-321	Integr. circuit	N74LS283N	5322 209 86052
322, 323	Integr. circuit	N74LS273N	5322 209 85792
324	Integr. circuit	N74LS174N	5322 209 81632
325, 326	Integr. circuit	N74LS273N	5322 209 85792
327	Integr. circuit	N74LS86N	5322 209 84997
328	Integr. circuit	N74LS153N	5322 209 85488
329	Integr. circuit	SN74LS151N	5322 209 86452
330	Integr. circuit	N74LS00N	5322 209 84823
331, 332	Integr. circuit	N74LS86N	5322 209 84997
333	Integr. circuit	N74LS174N	5322 209 81632
334	Integr. circuit	N74LS175N	5322 209 84999
335	Integr. circuit	N82S115N (sine ROM)	5322 209 82603
336, 337	Integr. circuit	N74LS157N	5322 209 81521
338	Integr. circuit	N74LS174N	5322 209 81632
339	Integr. circuit	N74LS175N	5322 209 84999
340, 341	Integr. circuit	N74LS86N	5322 209 84997
342	Integr. circuit	N74LS273N	5322 209 85792
343	Integr. circuit	N74LS175N	5322 209 84999
344, 345	Integr. circuit	N74S04N	5322 209 84475
346	Integr. circuit	MC1458N	4822 209 81349
347	Integr. circuit	SN74LS151N	5322 209 86452
348	Integr. circuit	HEF4050BP	4822 209 10261
TRANSISTORS / UNIT 2, DFS			
379, 402	Transistor	BC548B	4822 130 40937
401	Transistor	BC558B	4822 130 44197
403	Transistor	BC558C	5322 130 60068
404, 407	Transistor	BC558B	4822 130 44197
405, 406	Transistor	BC558C	5322 130 60068
408, 409	Transistor	BC558C	5322 130 60068
410, 413	Transistor	BC558B	4822 130 44197
411, 412	Transistor	BC558C	5322 130 60068
414, 415	Transistor	BC558C	5322 130 60068
416, 419	Transistor	BC558B	4822 130 44197
417, 418	Transistor	BC558C	5322 130 60068
420, 421	Transistor	BC558C	5322 130 60068
422, 425	Transistor	BC558B	4822 130 44197
423, 424	Transistor	BC558C	5322 130 60068
426, 427	Transistor	BC558C	5322 130 60068
428, 430	Transistor	BC558B	4822 130 44197
429	Transistor	BC558C	5322 130 60068
431	Transistor	BC548B	4822 130 40937

Pos. no.	Description				Ordering code
DIODES / UNIT 2, DFS					
451-460	Diode	BAW62			4822 130 30613
461, 463	Diode, ref.	BZX79B4V3			4822 130 31554
462, 464	Diode	BAW62			4822 130 30613
465, 467	Diode, ref.	BZX79B4V3			4822 130 31554
466, 468	Diode	BAW62			4822 130 30613
469, 471	Diode, ref.	BZX79B4V3			4822 130 31554
470, 472	Diode	BAW62			4822 130 30613
473, 475	Diode, ref.	BZX79B4V3			4822 130 31554
474, 476	Diode	BAW62			4822 130 30613
477	Diode, ref.	BZX79B4V3			4822 130 31554
478	Diode, ref.	BZV46X2V0			4822 130 31248
CAPACITORS / UNIT 2, DFS					
501, 507	Cap. ceramic	22 nF	+ 20/- 90 %	40 V	4822 122 30103
502	Cap. ceramic	22 pF	2 %	100 V	5322 122 32143
503	Cap. ceramic	56 pF	2 %	100 V	4822 122 32027
504	Cap. ceramic	33 pF	2 %	100 V	5322 122 32072
505	Cap. trimmer	2.5-27 pF		100 V	5322 125 54083
506	Cap. solid alu.	1 μ F		25 V	4822 124 20944
511-517	Cap. ceramic	22 nF	+ 20/- 90 %	40 V	4822 122 30103
518	Cap. electrolyt.	220 μ F		16 V	4822 124 40196
519	Cap. ceramic	22 nF	+ 20/- 90 %	40 V	4822 122 30103
520, 521	Cap. ceramic	4.7 nF	10 %	100 V	4822 122 31125
522	Cap. ceramic	82 pF	2 %	100 V	4822 122 31237
523, 524	Cap. ceramic	33 pF	2 %	100 V	5322 122 32072
525, 526	Cap. ceramic	4.7 nF	10 %	100 V	4822 122 31125
527	Cap. ceramic	82 pF	2 %	100 V	4822 122 31237
528	Cap. ceramic	33 pF	2 %	100 V	5322 122 32072
529, 530	Cap. ceramic	4.7 nF	10 %	100 V	4822 122 31125
531	Cap. ceramic	82 pF	2 %	100 V	4822 122 31237
532	Cap. ceramic	33 pF	2 %	100 V	5322 122 32072
533, 534	Cap. ceramic	4.7 nF	10 %	100 V	4822 122 31125
535	Cap. ceramic	82 pF	2 %	100 V	4822 122 31237
536	Cap. ceramic	33 pF	2 %	100 V	5322 122 32072
537, 538	Cap. ceramic	4.7 nF	10 %	100 V	4822 122 31125
539	Cap. ceramic	82 pF	2 %	100 V	4822 122 31237
540	Cap. ceramic	33 pF	2 %	100 V	5322 122 32072
541, 542	Cap. ceramic	4.7 nF	10 %	100 V	4822 122 31125
543	Cap. ceramic	82 pF	2 %	100 V	4822 122 31237
544, 548	Cap. ceramic	33 pF	2 %	100 V	5322 122 32072
545, 546	Cap. ceramic	4.7 nF	10 %	100 V	4822 122 31125
547	Cap. ceramic	82 pF	2 %	100 V	4822 122 31237
549	Cap. ceramic	22 nF	+ 20/- 90 %	40 V	4822 122 30103
550, 551	Cap. ceramic	4.7 nF	10 %	100 V	4822 122 31125
553	Cap. ceramic	82 pF	2 %	100 V	4822 122 31237
554	Cap. ceramic	22 nF	+ 20/- 90 %	40 V	4822 122 30103
555, 556	Cap. ceramic	4.7 nF	10 %	100 V	4822 122 31125
558	Cap. ceramic	22 nF	+ 20/- 90 %	40 V	4822 122 30103

Pos. no.	Description				Ordering code
559	Cap. ceramic	22 pF	2 %	100 V	5322 122 32143
560, 562	Cap. ceramic	180 pF	2 %	100 V	5322 122 31907
561	Cap. ceramic	10 pF	2 %	100 V	4822 122 32185
563	Cap. solid alu.	6.8 μ F		25 V	5322 124 14081
564, 566	Cap. solid alu.	10 μ F		16 V	4822 124 21314
565, 567	Cap. ceramic	22 nF	+ 20/- 90 %	40 V	4822 122 30103
RESISTORS / UNIT 2, DFS					
637	Res. metal film	619 Ω	0.1 %	0.25 W	5322 116 80212
639, 646	Res. metal film	1.87 k Ω	0.1 %	0.25 W	5322 116 80215
642, 649	Res. metal film	4.64 k Ω	0.1 %	0.25 W	5322 116 80216
643, 650	Res. metal film	1.69 k Ω	0.1 %	0.25 W	5322 116 80214
644, 651	Res. metal film	619 Ω	0.1 %	0.25 W	5322 116 80212
653, 660	Res. metal film	1.87 k Ω	0.1 %	0.25 W	5322 116 80215
656, 663	Res. metal film	4.64 k Ω	0.1 %	0.25 W	5322 116 80216
657, 664	Res. metal film	1.69 k Ω	0.1 %	0.25 W	5322 116 80214
658, 665	Res. metal film	619 Ω	0.1 %	0.25 W	5322 116 80212
667	Res. metal film	1.87 k Ω	0.1 %	0.25 W	5322 116 80215
670	Res. metal film	4.64 k Ω	0.1 %	0.25 W	5322 116 80216
671	Res. metal film	1.69 k Ω	0.1 %	0.25 W	5322 116 80214
672	Res. metal film	619 Ω	0.1 %	0.25 W	5322 116 80212
673	Res. metal film	11.5 k Ω	0.1 %	0.25 W	5322 116 51742
674	Res. metal film	9.53 k Ω	0.1 %	0.25 W	5322 116 80207
676	Potm. trimmer	470 Ω	carb.	0.1 W	4822 100 10038
679	Res. metal film	1.87 k Ω	0.1 %	0.25 W	5322 116 80215
682, 683	Res. metal film	4.64 k Ω	0.1 %	0.25 W	5322 116 80216
684, 685	Res. metal film	1.69 k Ω	0.1 %	0.25 W	5322 116 80214
686	Res. metal film	11.5 k Ω	0.1 %	0.25 W	5322 116 51742
687	Res. metal film	9.53 k Ω	0.1 %	0.25 W	5322 116 80207
689	Potm. trimmer	1 k Ω	carb.	0.1 W	4822 100 10037
693	Potm. trimmer	4.7 k Ω	CERMET	0.5 W	5322 101 10509
CRYSTAL / UNIT 2, DFS					
810	Crystal	8.59 MHz			5322 242 74407
COILS / UNIT 2, DFS					
802	Wide band choke				5322 158 10271
803	Choke				5322 158 20458
804	Choke				5322 158 20459

Pos. no.	Description		Ordering code
UNIT 3, KEYBOARD DISPLAY			
INTEGRATED CIRCUITS / UNIT 3			
351	Integr. circuit	HEF4049BP	4822 209 10306
352	Integr. circuit	MM5450N	4822 209 10199
353	Integr. circuit	SAA3007	5322 209 72061
TRANSISTOR / UNIT 3			
301	Transistor	BD646	4822 130 41212
DIODE / UNIT 3			
409, 410	Diode	BAW62	4822 130 30613
LEDs, DISPLAYS / UNIT 3			
401-404	LED	CQY54A	4822 130 31128
405-408	Display	LTM86 . . .	5322 130 90375
CAPACITORS / UNIT 3			
501	Cap. electrolyt.	220 μ H	16 V 4822 124 40196
502-504	Cap. ceramic	22 nF + 20/- 90 %	40 V 4822 122 30103
505, 506	Cap. ceramic	100 pF 2 %	100 V 4822 122 31316
507, 508	Cap. ceramic	22 nF + 20/- 90 %	40 V 4822 122 30103
SWITCHES / UNIT 3			
801	Key switch	M75120001	5322 276 14338
802-817	Key switch	M75120051	5322 276 14418
819, 820	Key switch	M75120001	5322 276 14338
821-828	Key switch	M75120051	5322 276 14418
829, 834	Key switch	M75120001	5322 276 14338
830-833	Key switch	M75120051	5322 276 14418
835-840	Key switch	M75120051	5322 276 14418
841	Key switch	M75120001	5322 276 14338
842	Key switch	M75120051	5322 276 14418
843-858	Key switch	M75120001	5322 276 14338
MISCELLANEOUS / UNIT 3			
860	Cer. resonator	455 kHz	5322 242 71606

Pos. no.	Description		Ordering code
UNIT 3, KEYBOARD DISPLAY			
INTEGRATED CIRCUITS / UNIT 3			
351	Integr. circuit	HEF4049BP	4822 209 10306
352	Integr. circuit	MM5450N	4822 209 10199
353	Integr. circuit	SAA3007	5322 209 72061
TRANSISTOR / UNIT 3			
301	Transistor	BD646	4822 130 41212
DIODE / UNIT 3			
409, 410	Diode	BAW62	4822 130 30613
LEDs, DISPLAYS / UNIT 3			
401-404	LED	CQY54A	4822 130 31128
405-408	Display	LTM86 . . .	5322 130 90375
CAPACITORS / UNIT 3			
501	Cap. electrolyt.	220 μ H	16 V 4822 124 40196
502-504	Cap. ceramic	22 nF + 20/- 90 %	40 V 4822 122 30103
505, 506	Cap. ceramic	100 pF 2 %	100 V 4822 122 31316
507, 508	Cap. ceramic	22 nF + 20/- 90 %	40 V 4822 122 30103
SWITCHES / UNIT 3			
801	Key switch	M75120001	5322 276 14338
802-817	Key switch	M75120051	5322 276 14418
819, 820	Key switch	M75120001	5322 276 14338
821-828	Key switch	M75120051	5322 276 14418
829, 834	Key switch	M75120001	5322 276 14338
830-833	Key switch	M75120051	5322 276 14418
835-840	Key switch	M75120051	5322 276 14418
841	Key switch	M75120001	5322 276 14338
842	Key switch	M75120051	5322 276 14418
843-858	Key switch	M75120001	5322 276 14338
MISCELLANEOUS / UNIT 3			
860	Cer. resonator	455 kHz	5322 242 71606

LACQUERED METAL FILM RESISTORS MR25

style	resistance range	tol. ±%	series	temperature coefficient ±ppm/°C	limiting voltage (r.m.s.) V	service code no. 5322 116 5.... followed by
MR 25	4,99 Ω – 301 kΩ	1	E96	50 *	250	

* For resistance values lower than 49,9 Ω: 100 ppm/°C.

4,99	0568	16,5	4109	54,9	4445	182	4493	604	4528
5,11	4192	16,9	0627	56,2	4446	187	4494	619	4529
5,23	4113	17,4	4432	57,6	4447	191	4495	634	4531
5,36	4239	17,8	0418	59	4448	196	0676	649	4532
5,49	4102	18,2	4083	60,4	4449	200	4496	665	4533
5,62	4128	18,7	0895	61,9	4451	205	0669	681	4534
5,76	4413	19,1	4104	63,4	4375	210	4036	698	4037
5,90	1064	19,6	0473	64,9	4453	215	0457	715	0571
6,04	4114	20	1048	66,5	4454	221	4002	732	4535
6,19	1049	20,5	0678	68,1	4455	226	4497	750	4536
6,34	0862	21	4433	69,8	4456	232	4498	768	4537
6,49	4112	21,5	0677	71,5	4457	237	0679	787	4538
6,65	4414	22,1	0983	73,2	4458	243	0437	806	4539
6,81	4013	22,6	0491	75	4459	249	4499	825	4541
6,98	4103	23,2	4434	76,8	0494	255	4501	845	4542
7,15	4415	23,7	4014	78,7	0578	261	4502	866	4543
7,32	4416	24,3	4435	80,6	4461	267	4503	887	4544
7,50	4417	24,9	0903	82,5	4462	274	4504	909	4545
7,68	4418	25,5	4436	84,5	4463	280	4505	931	4546
7,87	4046	26,1	0876	86,6	4464	287	4506	953	4547
8,06	4419	26,7	4067	88,7	4465	294	4507	976	4548
8,25	4099	27,4	0493	90,9	4466	301	4508	1K	4549
8,45	4421	28	0623	93,1	4467	309	4509	1K02	4551
8,66	1051	28,7	4068	95,3	0569	316	4511	1K05	4552
8,87	4101	29,4	4084	97,6	4468	324	4512	1K07	4553
9,09	0863	30,1	0904	100	4469	332	4513	1K1	4554
9,31	4422	30,9	4437	102	4471	340	4514	1K13	4555
9,53	4258	31,6	4034	105	4472	348	4515	1K15	0415
9,76	4423	32,4	4105	107	4473	357	0603	1K18	4556
10	0452	33,2	0527	110	4474	365	4516	1K21	4557
10,2	4111	34	4438	113	4475	374	4517	1K24	4559
10,5	4071	34,8	4027	115	4476	383	4518	1K27	0555
10,7	4424	35,7	4439	118	4477	392	4006	1K3	0526
11	4059	36,5	0409	121	4426	402	4519	1K33	4561
11,3	4425	37,4	4158	124	4478	412	4521	1K37	0628
11,5	0838	38,3	0954	127	4479	422	0459	1K4	4562
11,8	0738	39,2	4087	130	4481	432	4522	1K43	4563
12,1	4069	40,2	0926	133	4482	442	0592	1K47	0635
12,4	4427	41,2	4108	137	4483	453	4523	1K5	4564
12,7	4261	42,2	1052	140	4484	464	0536	1K54	0586
13	4082	43,2	0519	143	4485	475	4007	1K58	0622
13,3	1047	44,2	0818	147	0766	487	0508	1K62	4565
13,7	4428	45,3	0795	150	4486	499	4524	1K65	4566
14	0839	46,4	0492	154	0506	511	4525	1K69	4567
14,3	4429	47,5	0952	158	4487	523	4526	1K74	0629
14,7	0412	48,7	0511	162	0417	536	0621	1K78	5015
15	0902	49,9	4441	165	4488	549	0732	1K82	4568
15,4	0925	51,1	4442	169	4489	562	4009	1K87	0728
15,8	0861	52,3	4443	174	4491	576	4527	1K91	4569
16,2	4431	53,6	4444	178	4492	590	0561	1K96	4571

2K	4572	6K65	4604	22K1	4003	73K2	0666	243K	4733
2K05	0664	6K81	4012	22K6	0481	75K	4686	249K	4734
2K1	4573	6K98	4605	23K2	4645	76K8	4687	255K	4735
2K15	0767	7K15	4606	23K7	4646	78K7	0533	261K	4736
2K21	4574	7K32	4607	24K3	4647	80K6	4688	267K	4737
2K26	0675	7K5	4608	24K9	4648	82K5	4689	274K	4738
2K32	4575	7K68	4609	25K5	4649	84K5	4691	280K	4739
2K37	4576	7K87	0458	26K1	4651	86K6	4692	287K	4741
2K43	4004	8K06	4611	26K1	4652	88K7	4693	294K	4742
2K49	0581	8K25	4558	27K4	0559	90K9	4694	301K	4743
2K55	4577	8K45	4612	28K	0667	93K1	4297	316 K	5268
2K61	0671	8K66	4613	28K7	4653	95K3	0567	332 K	1184*
2K67	4578	8K87	4614	29K4	4654	97K6	4695	348 K	5499
2K74	0636	9K09	4615	30K1	4655	100K	4696	365 K	5641
2K8	4579	9K31	4616	30K9	4656	102K	4697	374 K	5457
2K87	0414	9K53	4617	31K6	4657	105K	4698	383 K	5335
2K94	4581	9K76	4618	32K4	4658	107K	4699	402 K	5283
3K01	0524	10K	4619	33K2	0482	110K	4701	412 K	5424
3K09	4582	10K2	4621	34K	4659	113K	4702	422 K	5247
3K16	0579	10K5	0731	34K8	4661	115K	4279	442 K	5458
3K24	4583	10K7	4622	35K7	4662	118K	4703	464 K	5207
3K32	4005	11K	4623	36K5	0726	121K	4704	475 K	1275
3K4	4584	11K3	0668	37K4	4663	124K	4705	499 K	5468
3K48	4585	11K5	4624	38K3	0483	127K	4706	511 K	5258
3K57	4586	11K8	4625	39K2	4664	130K	4707	536 K	4758
3K65	4587	12K1	0572	40K2	4665	133K	4708	562 K	1169
3K74	4588	12K4	4626	41K2	4666	137K	4709	590 K	5567
3K83	4589	12K7	0443	42K2	0474	140K	4259	619 K	5315
3K92	4591	13K	0522	43K2	4667	143K	4711	649 K	5331
4K02	4592	13K3	4627	44K2	4668	147K	4712	681 K	5284
4K12	4593	13K7	4628	45K3	4669	150K	4713	750 K	5532
4K22	0729	14K	4629	46K4	0557	154K	4714	806 K	1369
4K32	4594	14K3	4631	47K5	4671	158K	4715	825 K	1398
4K42	0556	14K7	4632	48K7	0442	162K	4716	866 K	1395
4K53	0631	15K	4001	49K9	0674	165K	4717	909 K	5533
4K64	0484	15K4	0479	51K1	0672	169K	4718	953 K	1368
4K75	4008	15K8	4633	52K3	4673	174K	4719	1MAO	5535
4K87	0509	16K2	0593	53K6	4674	178K	4721		
4K99	0523	16K5	4634	54K9	4675	182K	4722		
5K11	4595	16K9	4635	56K2	4676	187K	4723		
5K23	4596	17K4	4636	57K6	4677	191K	4724		
5K36	4597	17K8	4637	59K	4678	196K	4725		
5K49	4598	18K2	4638	60K4	4679	200K	4726		
5K62	4011	18K7	0558	61K9	0872	205K	4727		
5K76	4599	19K1	4639	63K4	4681	210K	4208		
5K9	0583	19K6	4641	64K9	0514	215K	4728		
6K04	4601	20K	4642	66K5	4682	221K	4038		
6K19	0608	20K5	4643	68K1	4683	226K	4729		
6K34	4602	21K	4644	69K8	4684	232K	4731		
6K49	4603	21K5	0451	71K5	4685	237K	4732		

* 4822 116 5....

FIGURES 28 – 44

- Fig. 28 Unit 2, adjusting elements
- Fig. 29 Unit 1, adjusting elements
- Fig. 30 Block diagram
- Fig. 31 Front view
- Fig. 32 Rear view
- Fig. 33 Overall circuit diagram
- Fig. 34 Unit 1, component lay-out
- Fig. 35 Power supply
- Fig. 36 Unit 1, pulse generator
- Fig. 37 Unit 1, PLL/VCO
- Fig. 38 Unit 1, output amplifier
- Fig. 39 Unit 1, modulator
- Fig. 40 Unit 2, component lay-out
- Fig. 41 Unit 2, CPU
- Fig. 42 Unit 3, (keyboard/display) component lay-out
- Fig. 43 Unit 3, keyboard display
- Fig. 44 Unit 2, digital frequency synthesis (DFS)

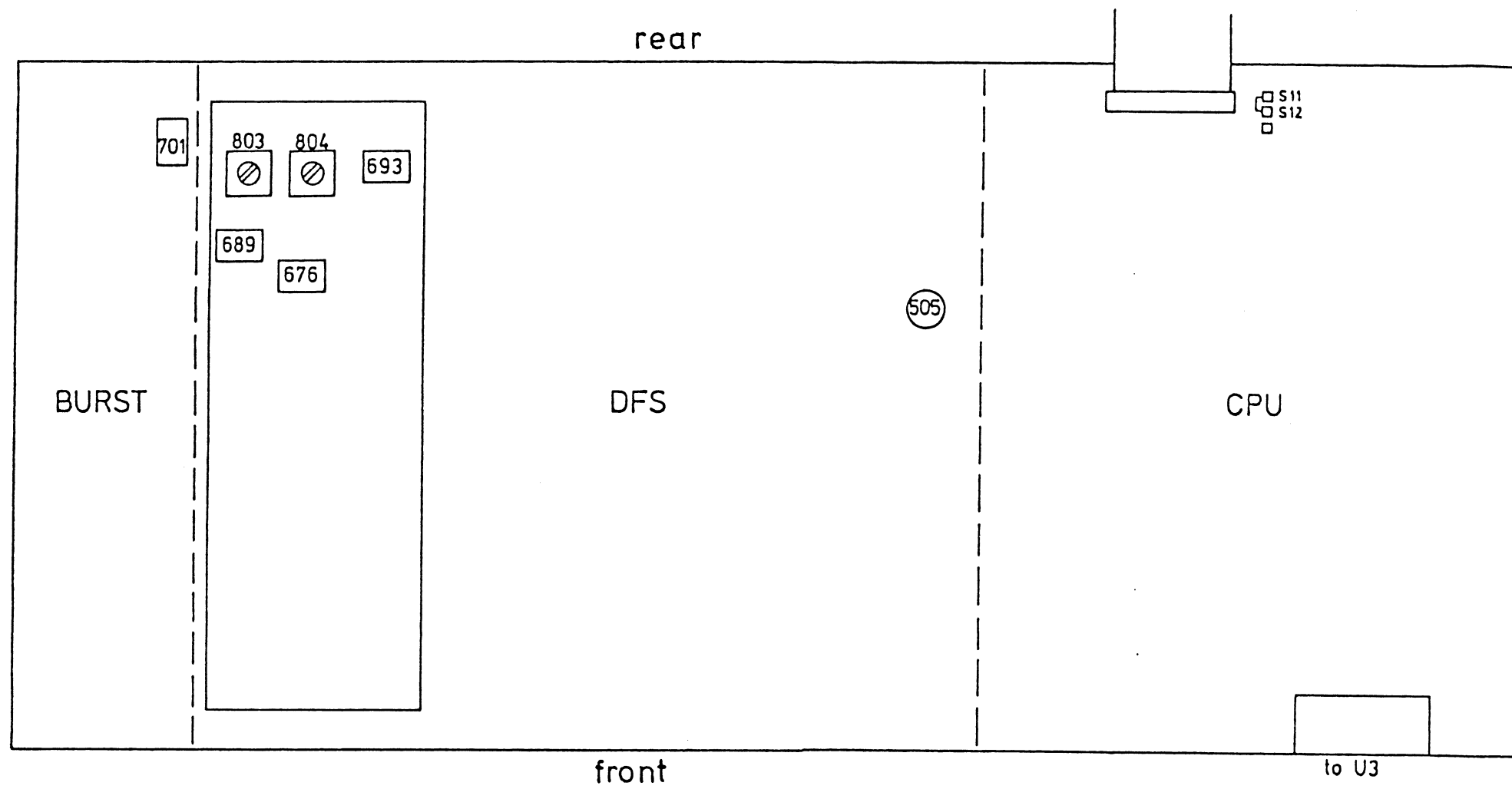

component side

Fig. 28
Unit 2
adjusting elements

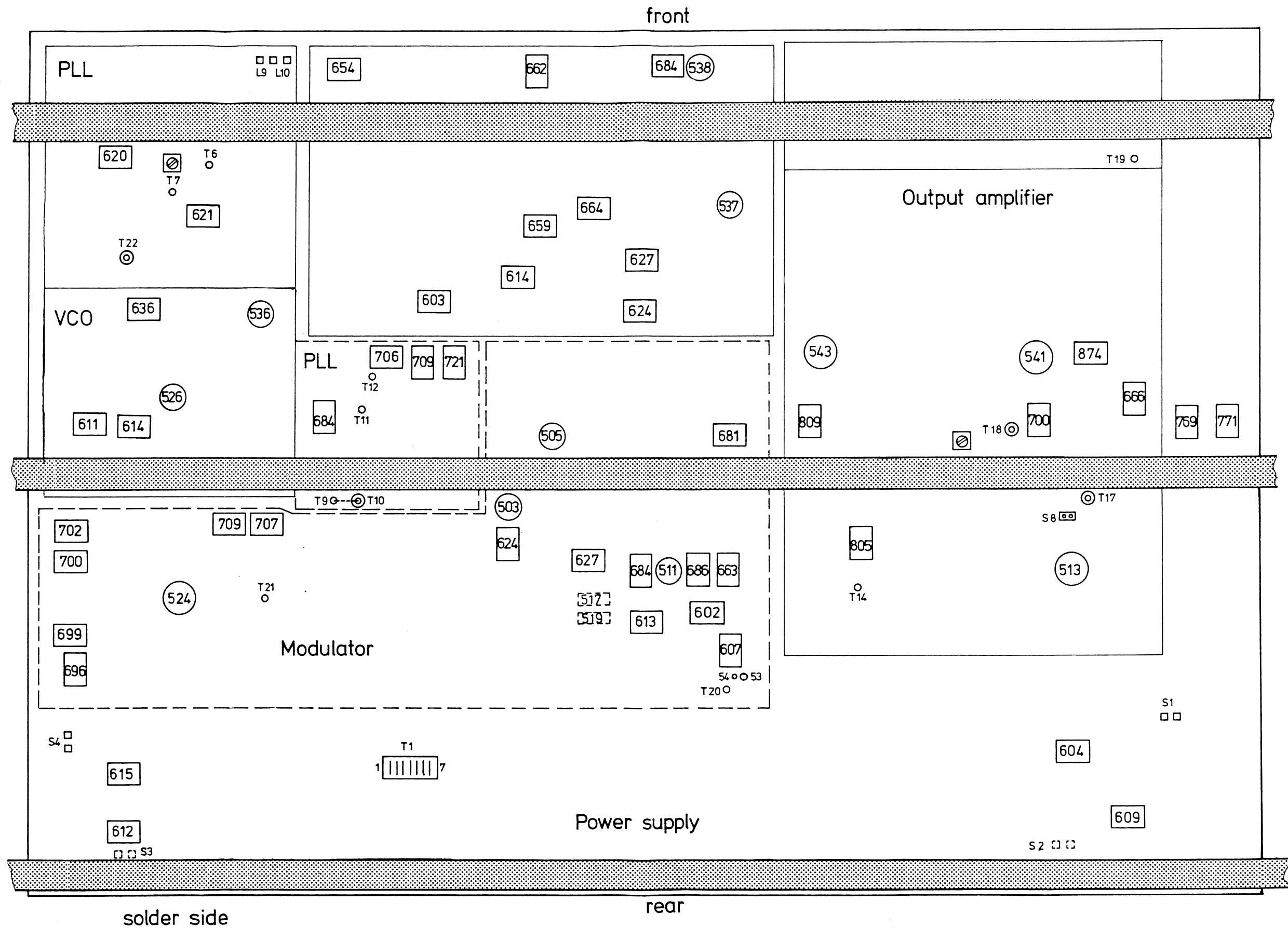

Fig. 29
Unit 1
adjusting elements

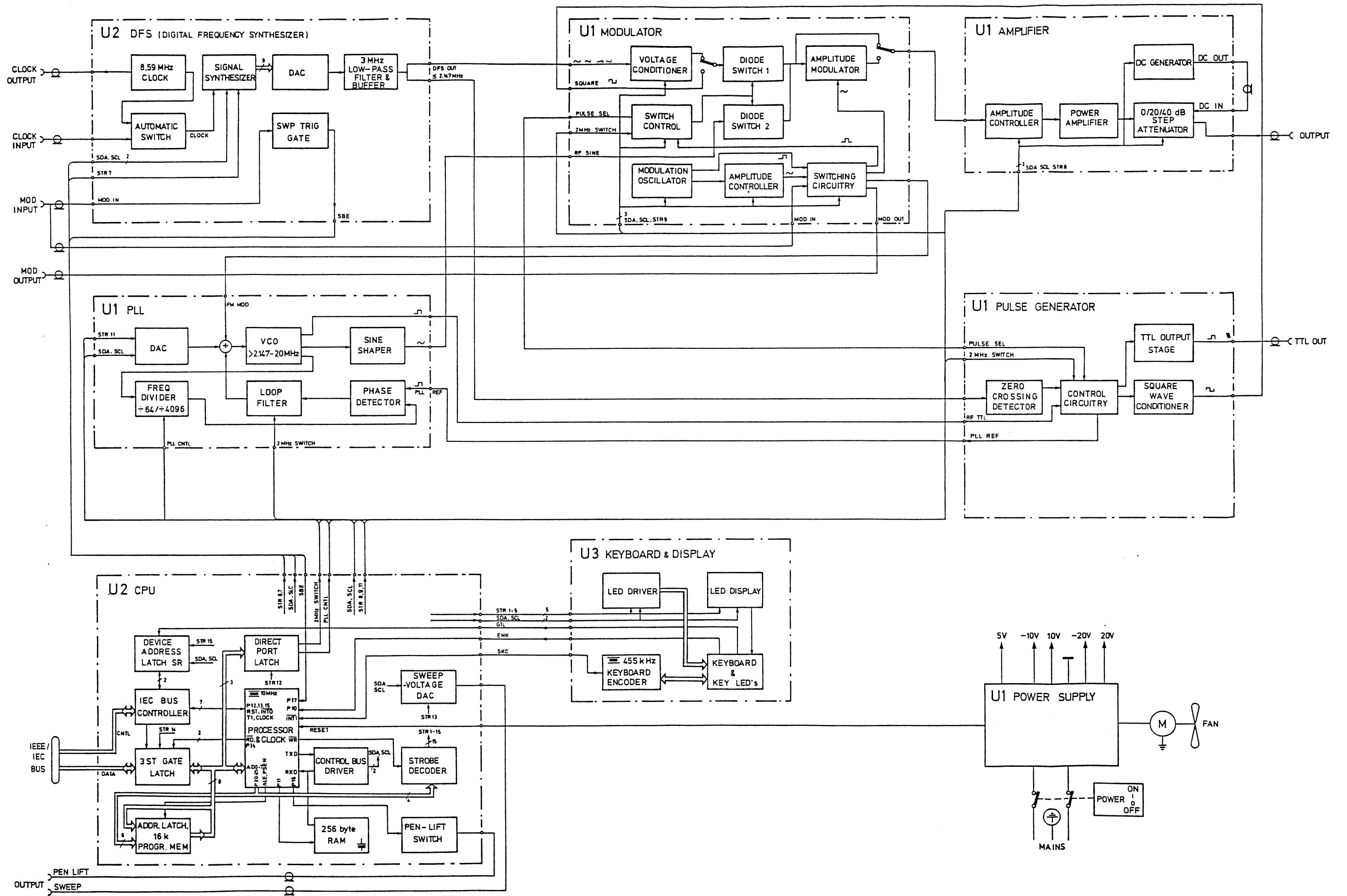

Fig. 30 Block diagram

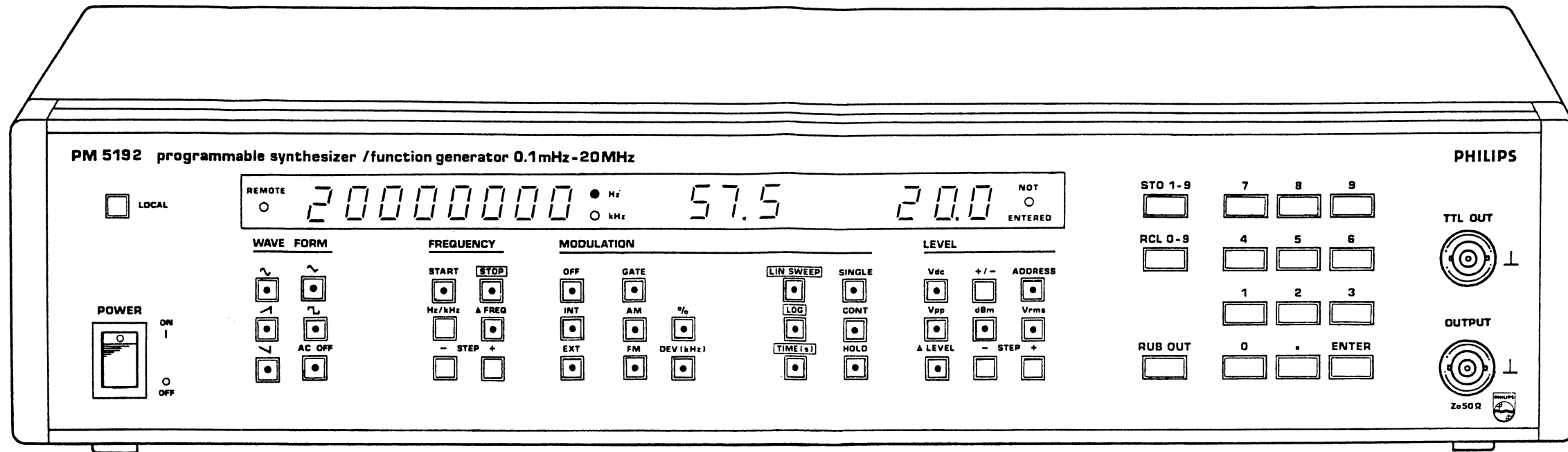

Fig. 31 Front view

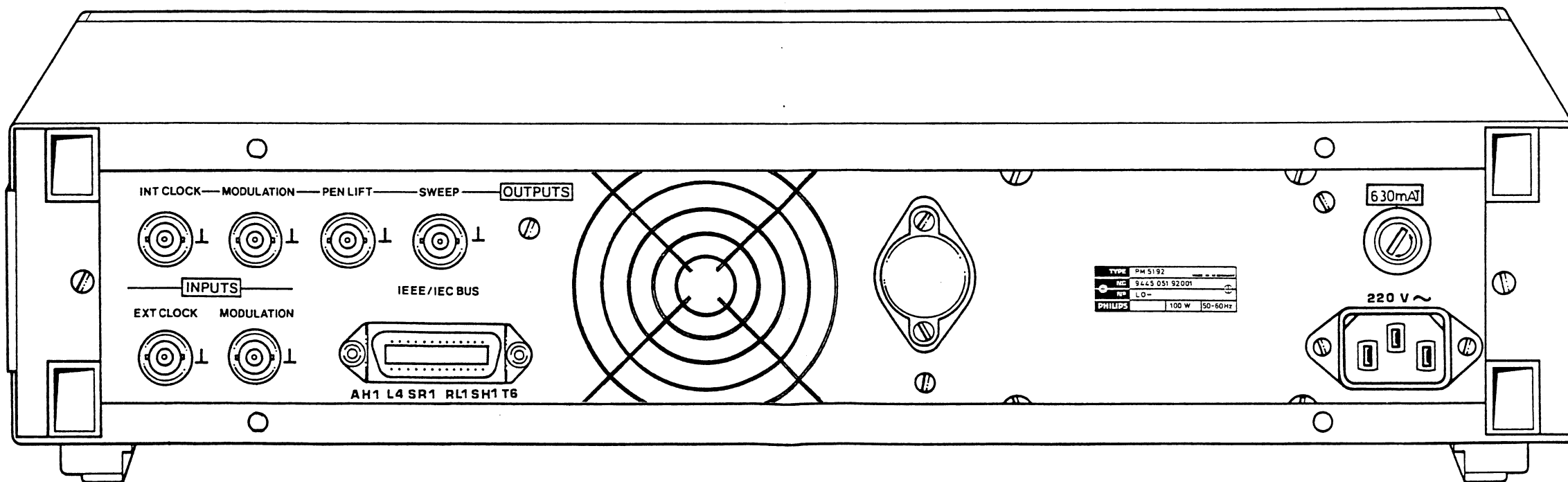
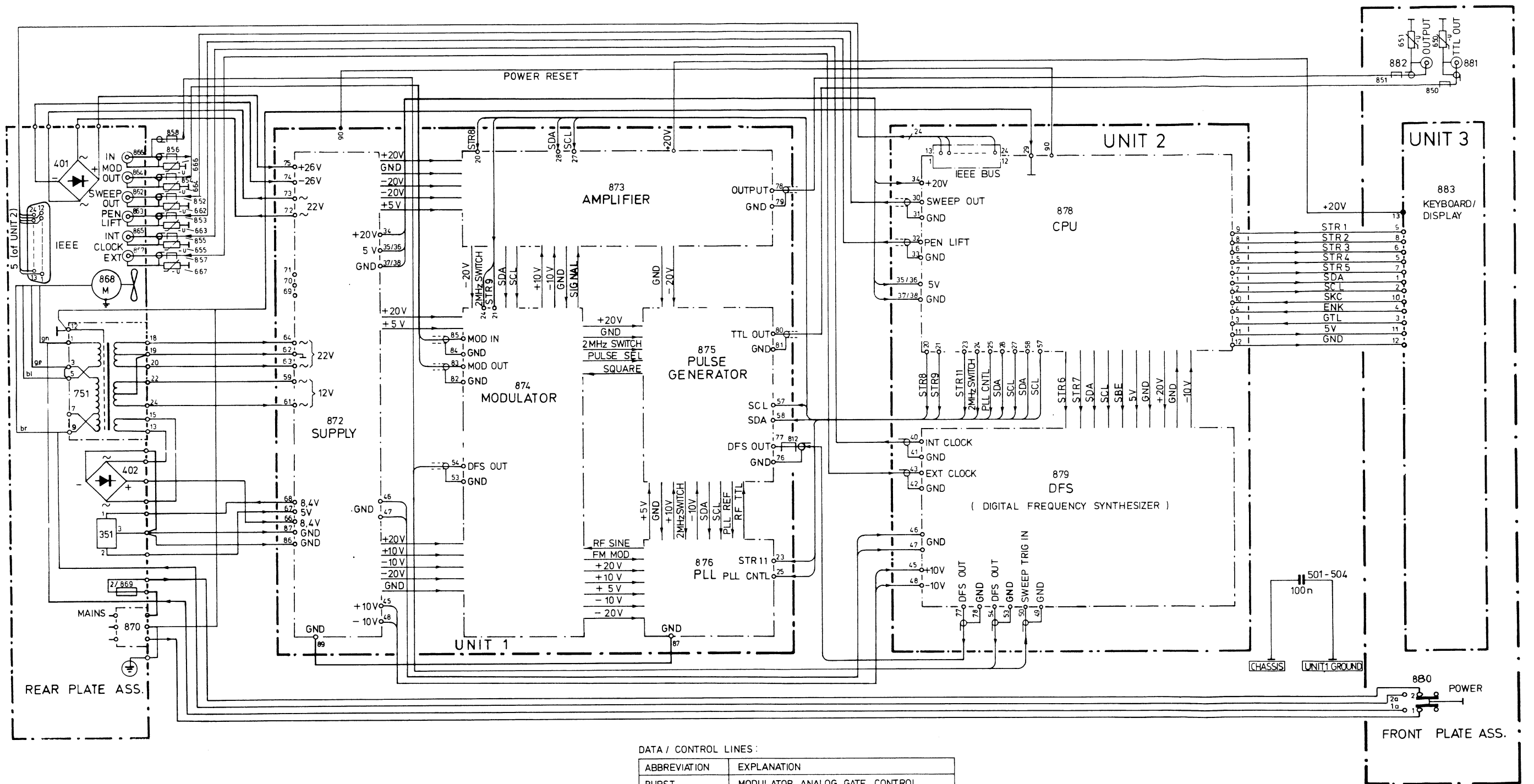

Fig. 32 Rear view



DATA / CONTROL LINES :

ABBREVIATION	EXPLANATION
BURST	MODULATOR ANALOG GATE CONTROL
2 MHz SWITCH	2.16 MHz SWITCH OVER
SDA	SERIAL DATA LINE
SCL	SERIAL CLOCK LINE
PULSE SELECT	SQUARE WAVE AND PULSE SELECT
STR	STROBE
PLL CNTL	PLL INTEGRATOR TIME CONSTANT CONTROL
SBE	SINGLE BURST END INDICATION
SKC	SERIAL KEYBOARD CODE
ENK	ENABLE KEYBOARD
GTL	GO TO LOCAL

Fig. 33 Overall circuit diagram

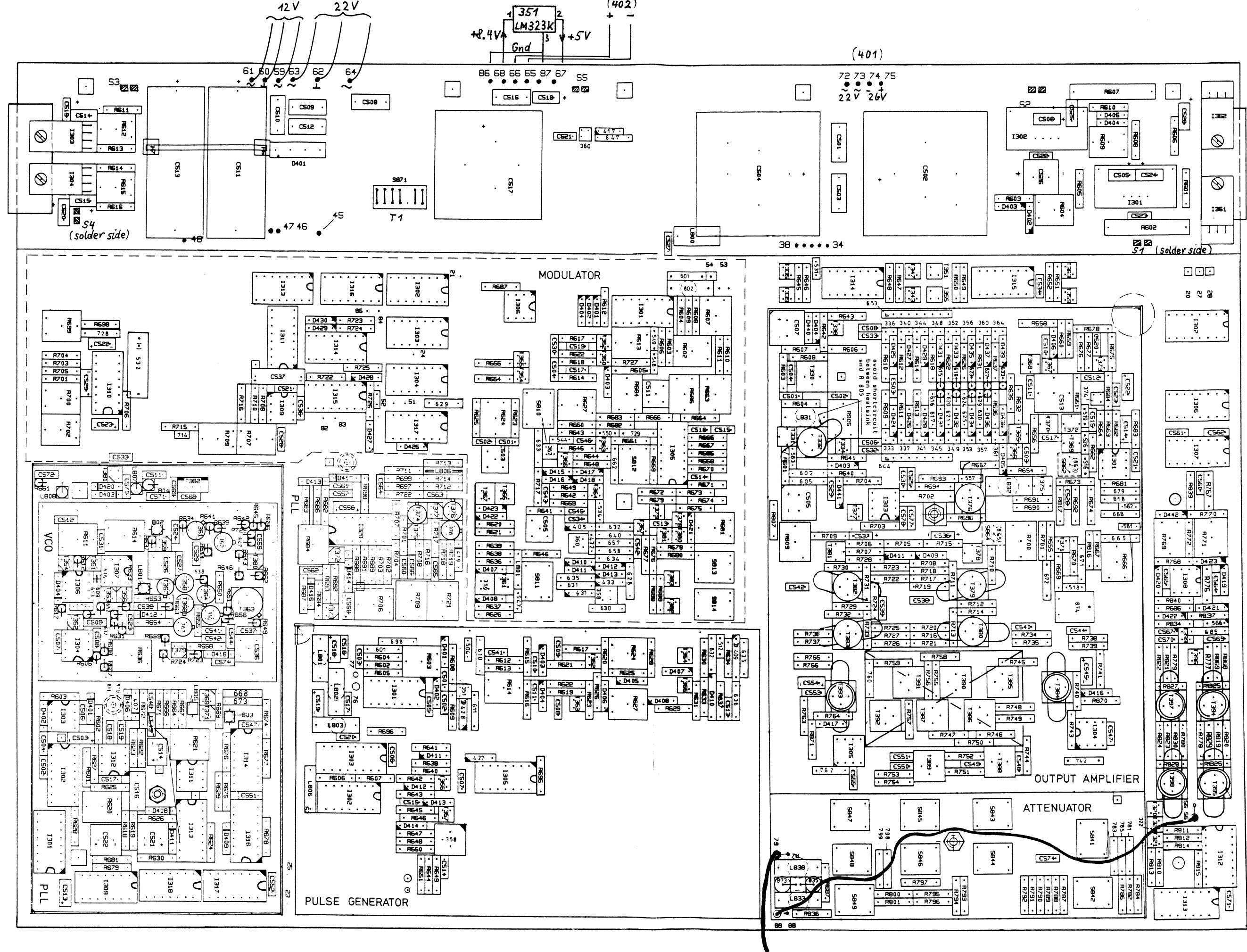

Fig. 34 Unit 1, component lay-out

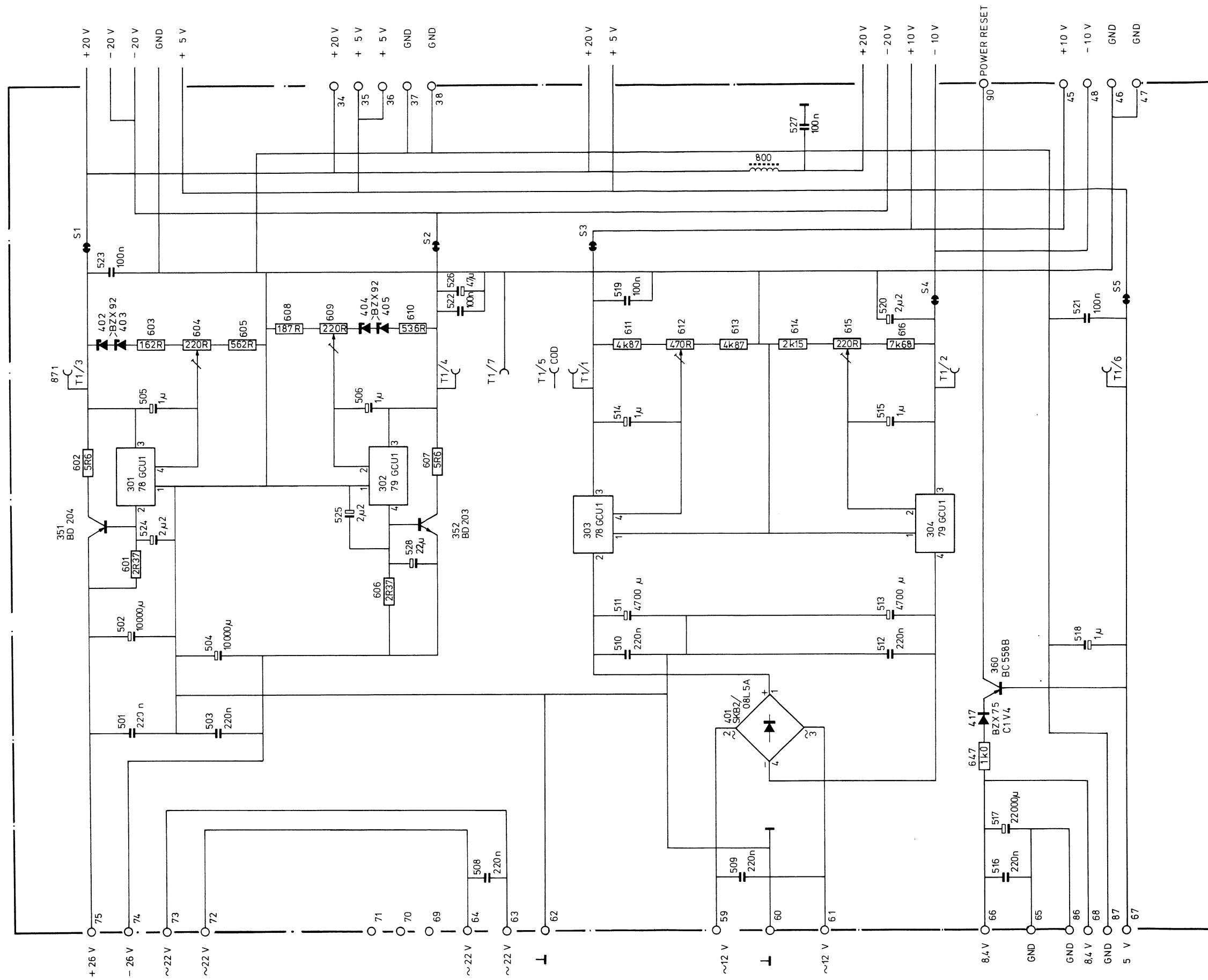
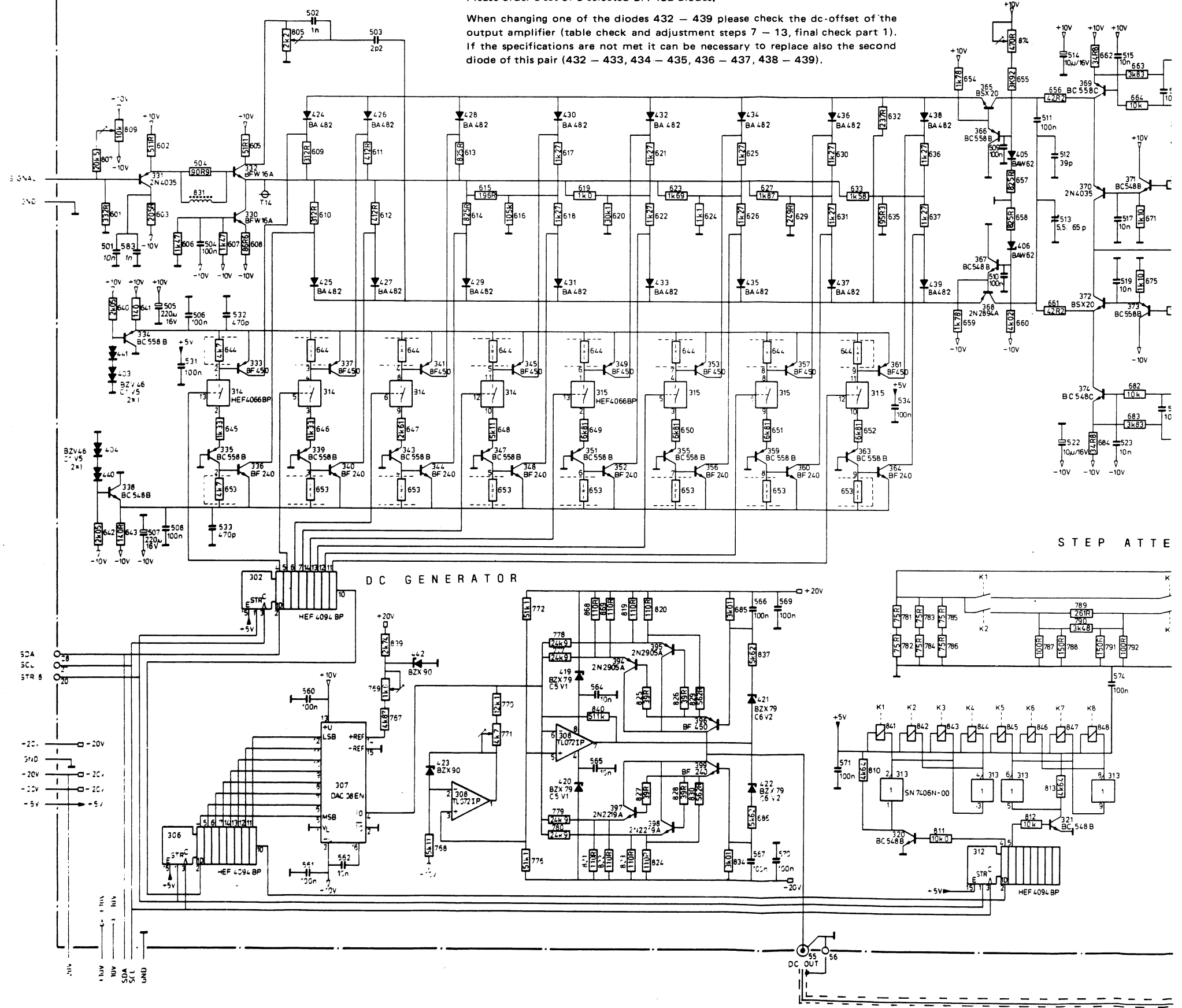

Fig. 35 Unit 1, power supply

AMPLITUDE CONTROLLER

If one of the diodes 424 - 431 is defective, all these diodes must be replaced. Please order a set of 8 selected BA 482 diodes.

When changing one of the diodes 432 - 439 please check the dc-offset of the output amplifier (table check and adjustment steps 7 - 13, final check part 1). If the specifications are not met it can be necessary to replace also the second diode of this pair (432 - 433, 434 - 435, 436 - 437, 438 - 439).



STEP ATTE

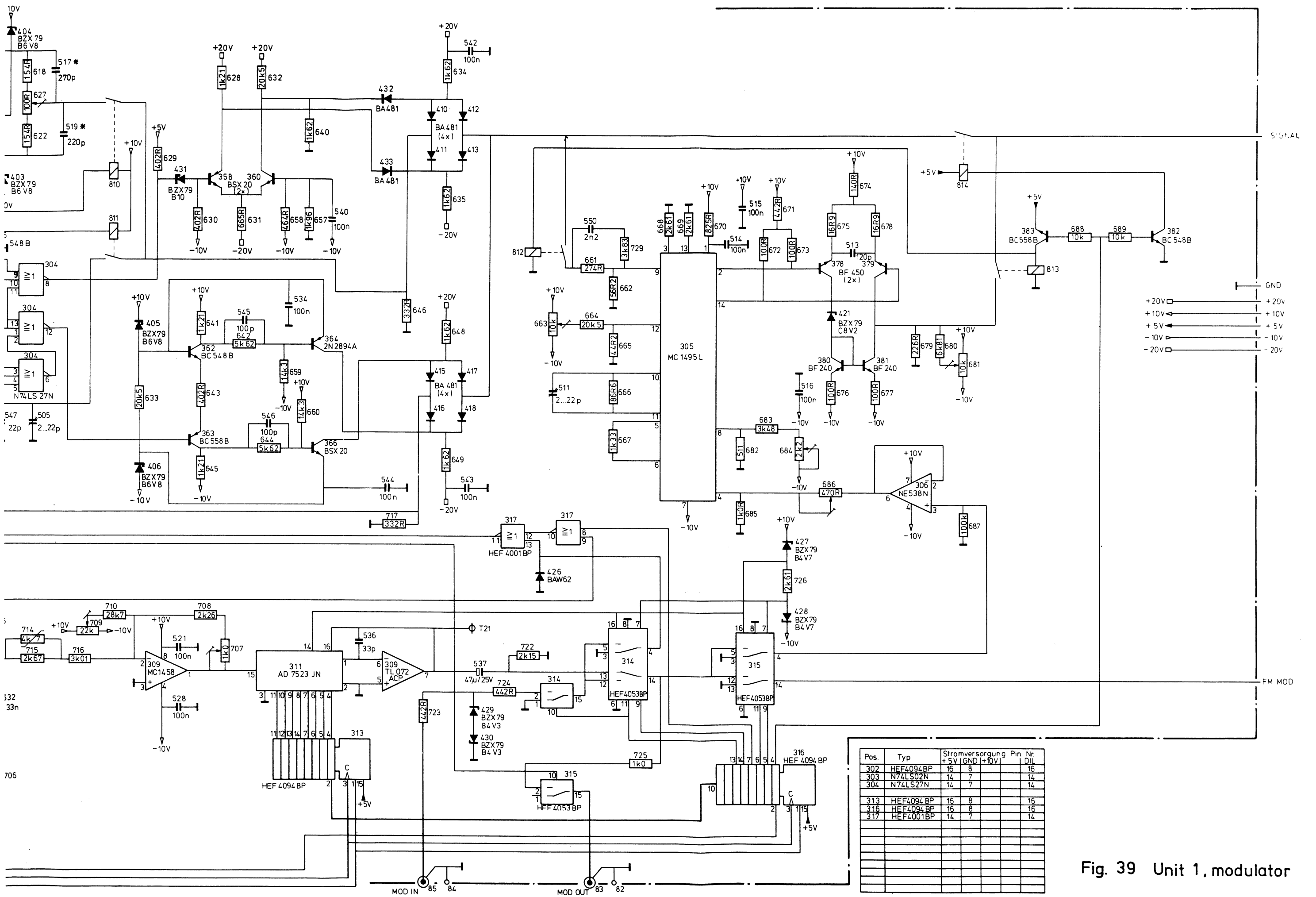

Fig. 39 Unit 1, modulator

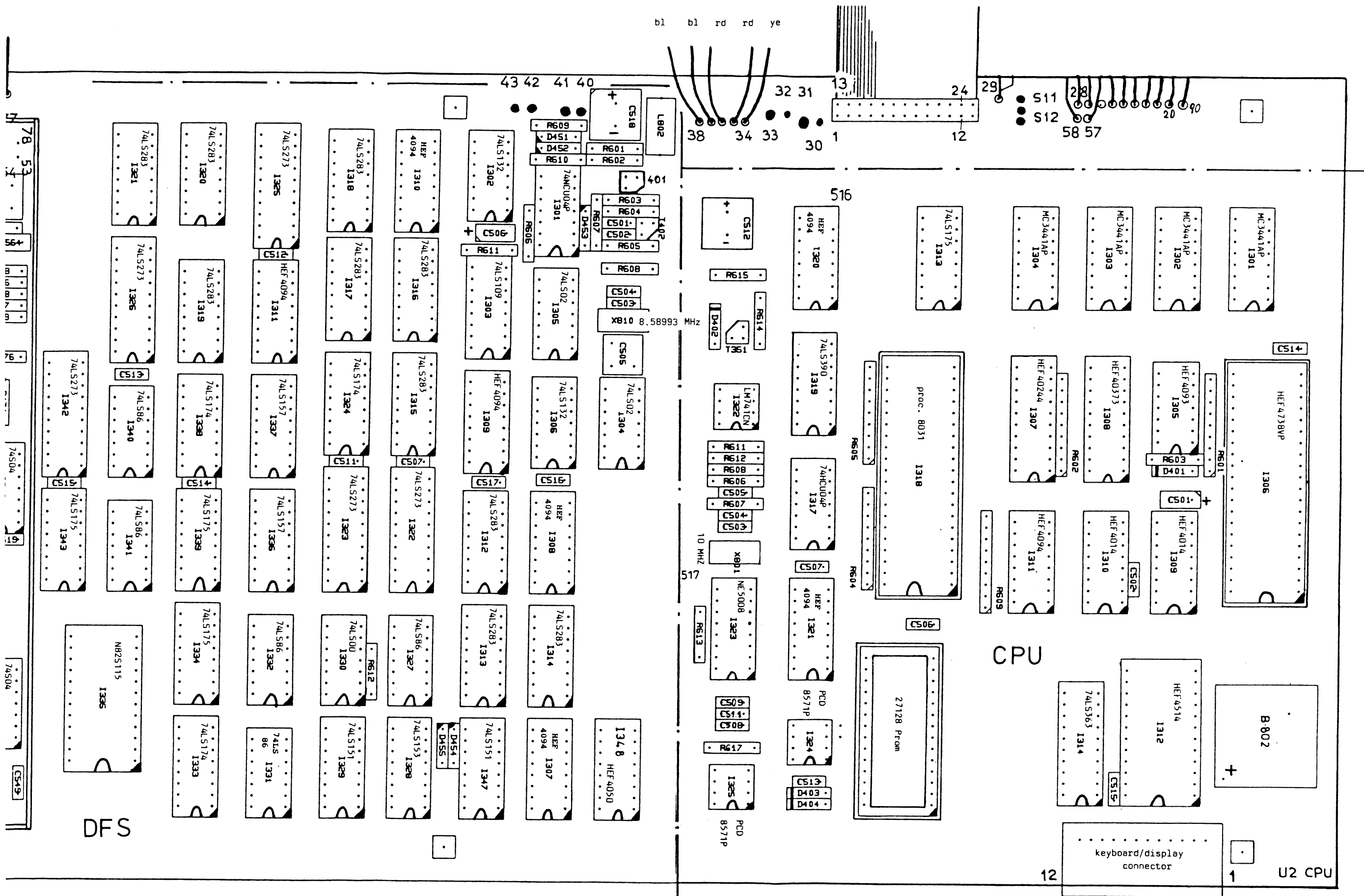
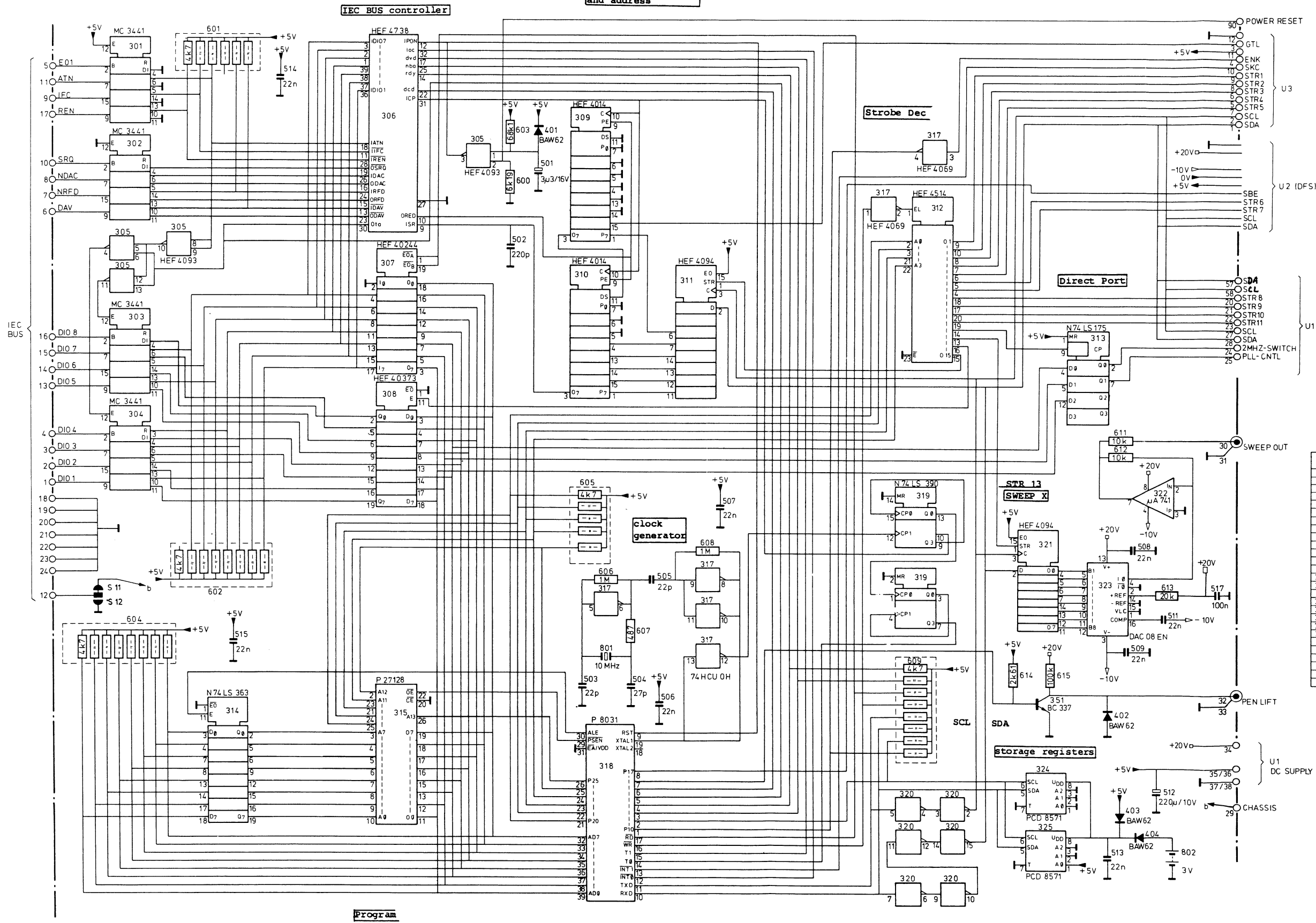

Fig. 40 Unit 2, component lay-out

**IEC BUS
interface functions
and address**



Pos	Typ	Stromversorgung	PIN
301	MC 3441	+5V	16 8 16
302	-	-	16 8 16
303	-	-	16 8 16
304	-	-	16 8 16
305	HEF 4093	14 7 14	
306	-	4.0 20 4.0	
307	-	4.0 24.4 20 10 20	
308	-	4.0 37.3 20 10 20	
309	-	4.0 14 16 8 16	
310	-	16 8 16	
311	-	4.0 9.4 16 8 16	
312	-	4.5 14 24 12 24	
313	N74LS 175	16 8 16	
314	N74LS 363	20 10 20	
315	P 27 128	2.8 14 2.8	
317	74 HCU 04	14 7 14	
318	P 8031	4.0 20 4.0	
319	N74LS 390	16 8 16	
320	HEF 4094	1 8 16	
321	-	4.0 9.4 16 8 16	
324	PCD 8571	4 8	
325	-	4 8	

Fig. 41 Unit 2, CPU

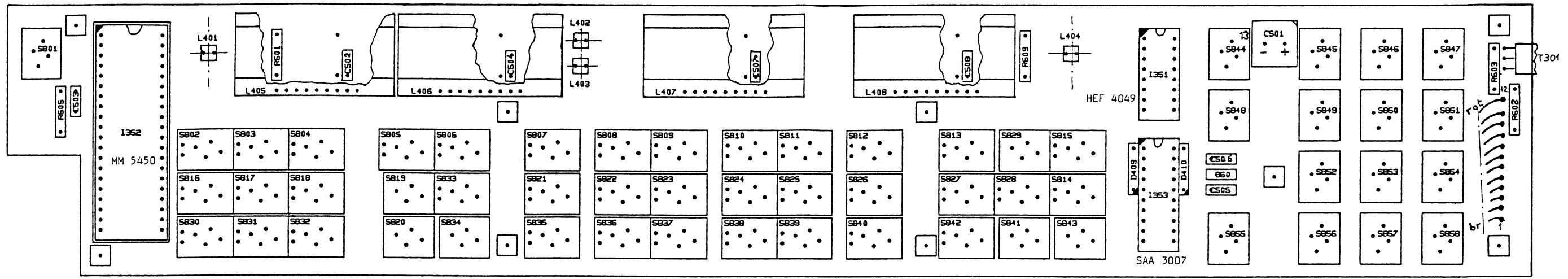

Fig. 42 Unit 3, Keyboard/display component lay-out

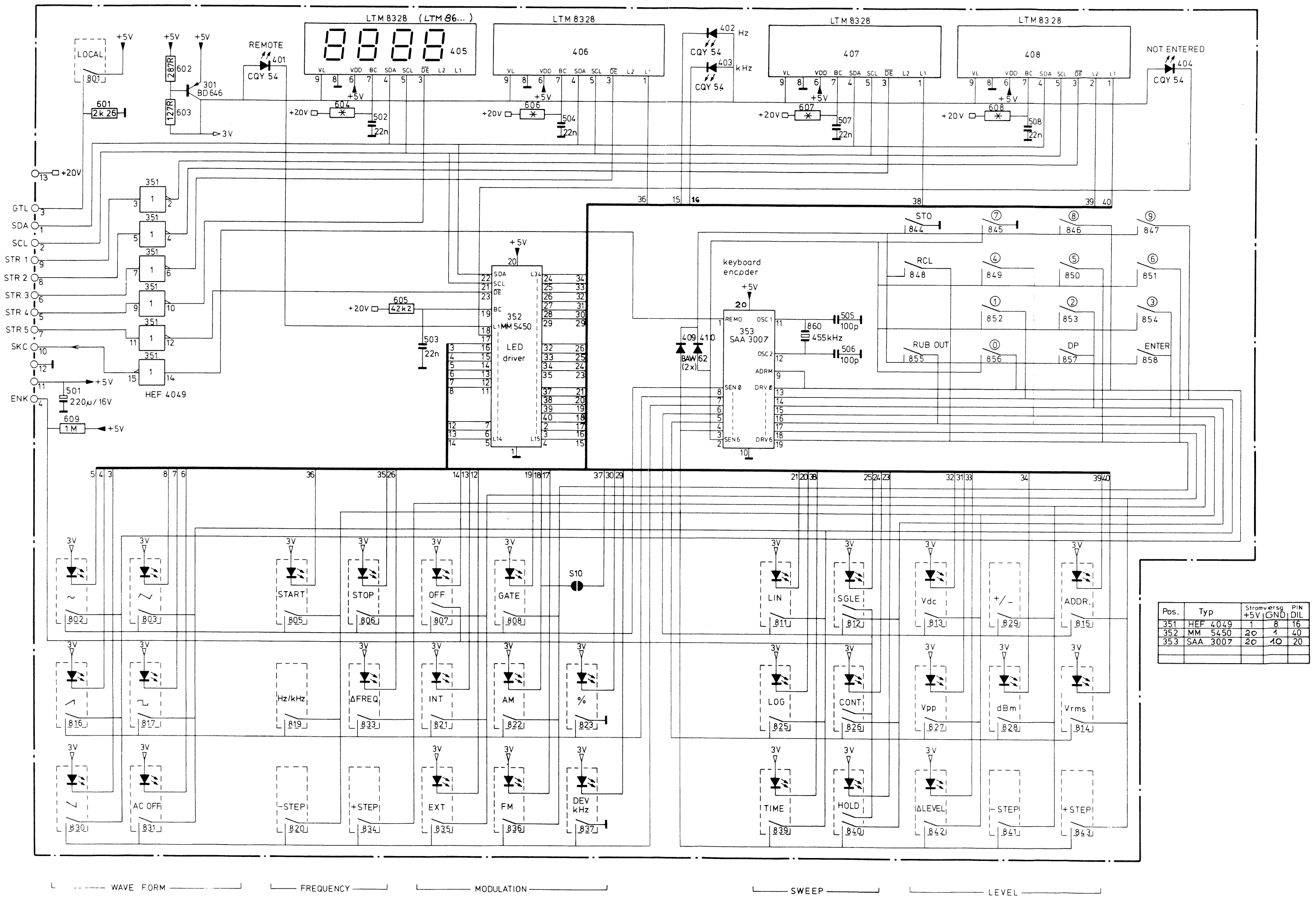
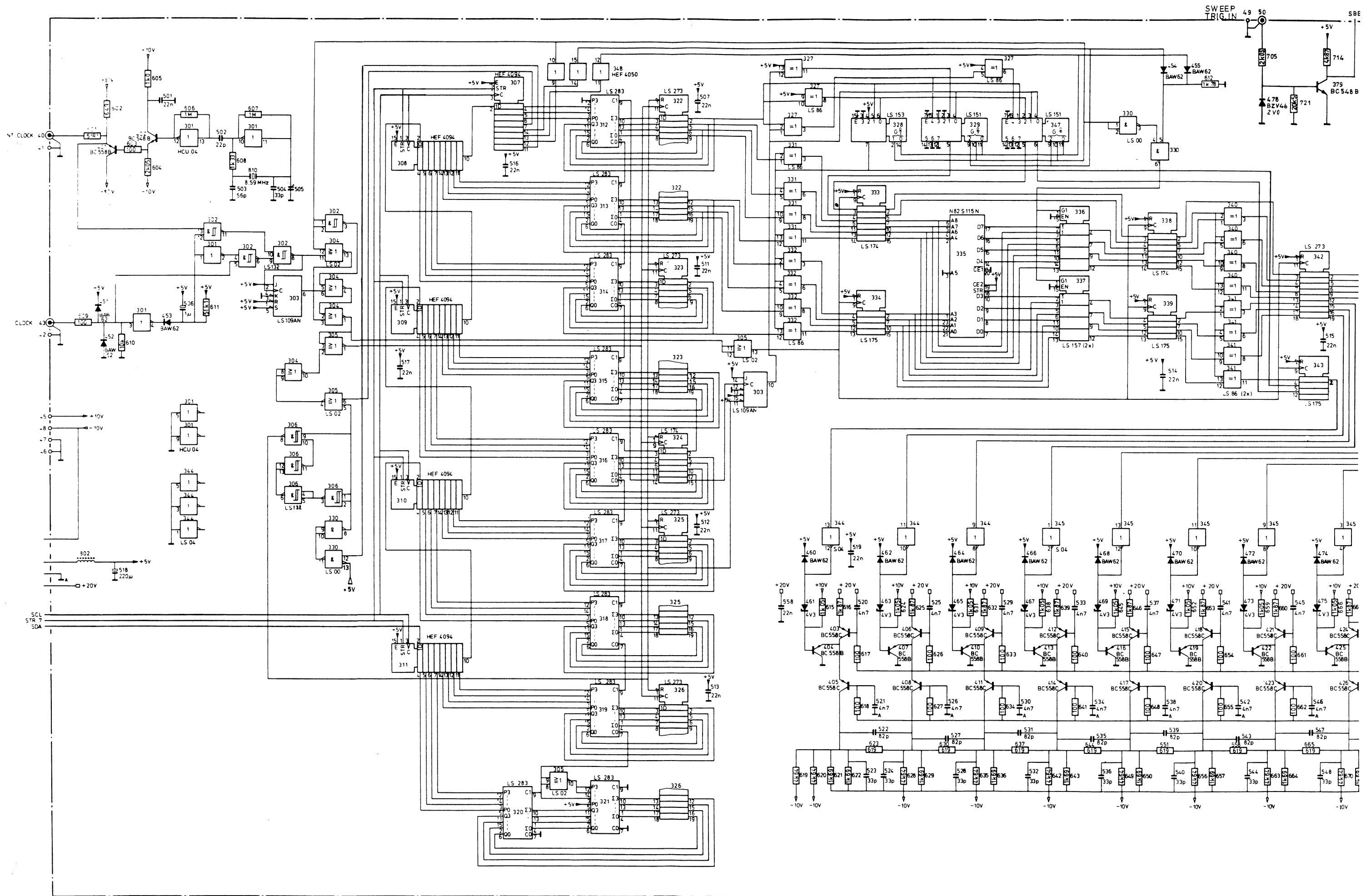
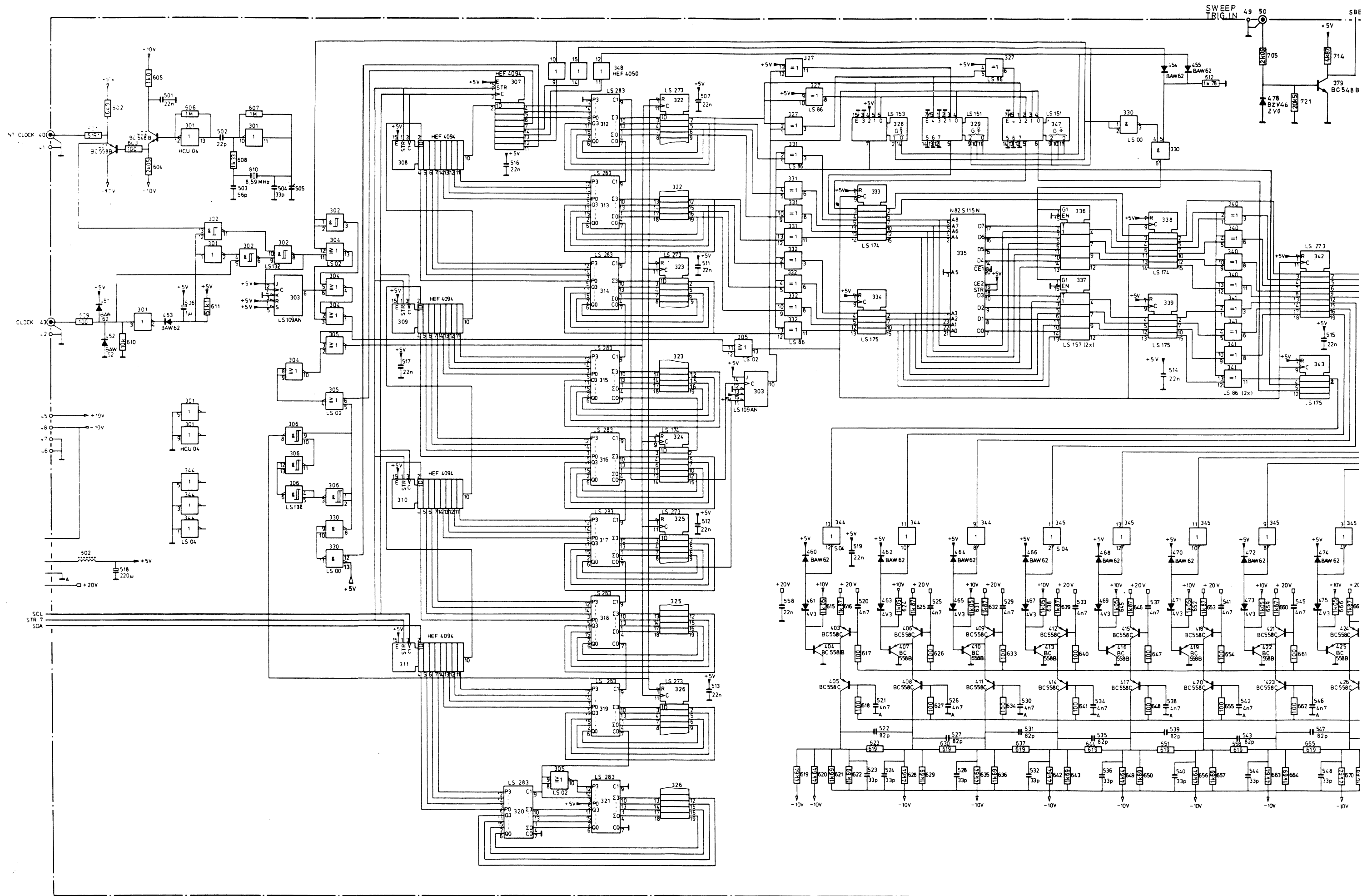
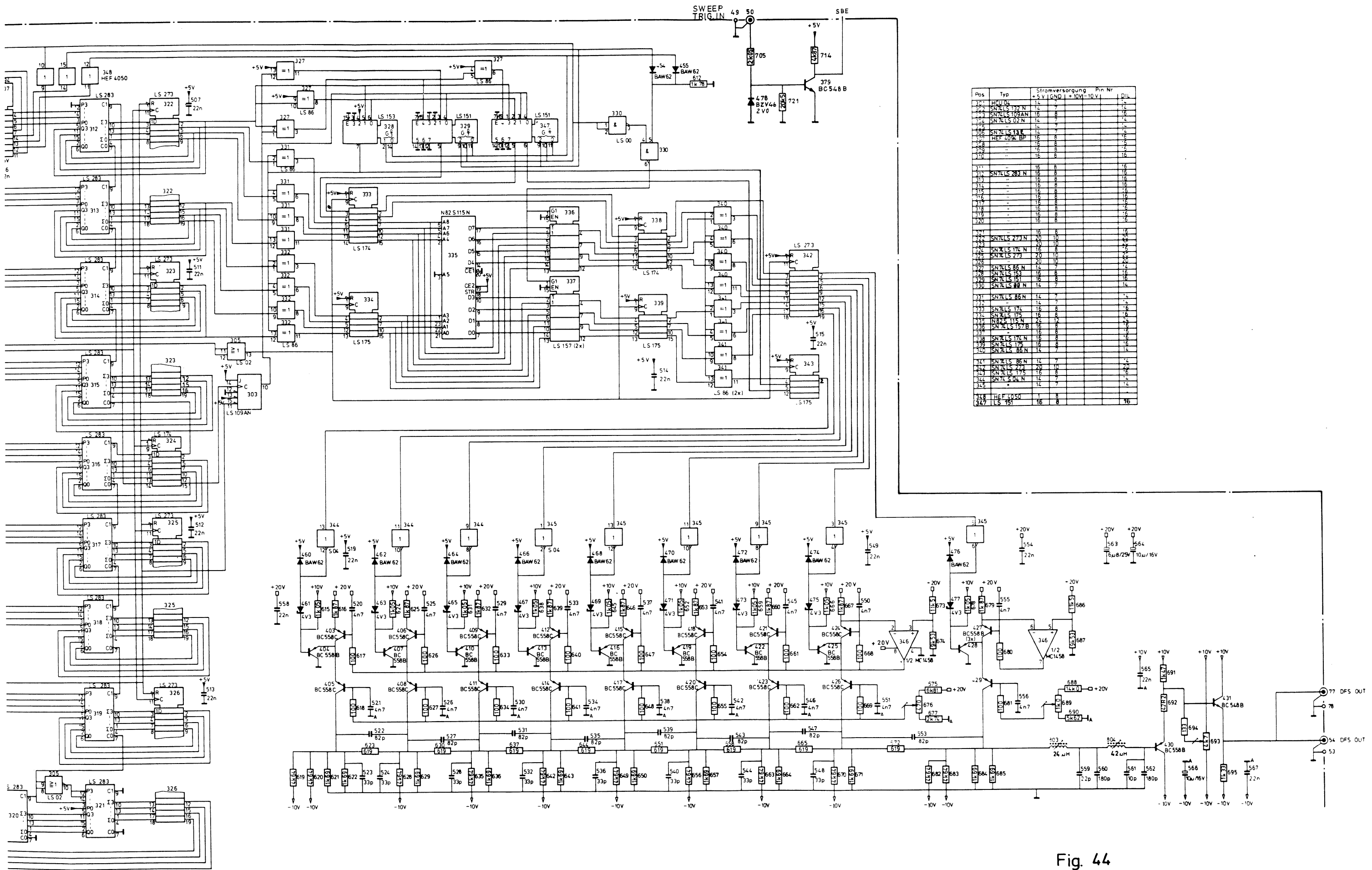

Fig. 43 Unit 3, keyboard display







Pos	Typ	Stromversorgung	Pin Nr	DIL
327	HEF 4050	+5V GND +10V -10V	1	16
328	SN74LS112 N	+	7	16
329	SN74LS109AN	+	8	16
330	SN74LS02 N	+	7	16
331	SN74LS138	+	7	16
332	HEF 4050 BP	+	8	16
333	SN74LS138	+	8	16
334	SN74LS138	+	8	16
335	SN74LS138	+	8	16
336	SN74LS138	+	8	16
337	SN74LS138	+	8	16
338	SN74LS138	+	8	16
339	SN74LS138	+	8	16
340	SN74LS138	+	8	16
341	SN74LS138	+	8	16
342	SN74LS138	+	8	16
343	SN74LS138	+	8	16
344	SN74LS138	+	8	16
345	SN74LS138	+	8	16
346	SN74LS138	+	8	16
347	SN74LS138	+	8	16
348	SN74LS138	+	8	16
349	SN74LS138	+	8	16
350	SN74LS138	+	8	16
351	SN74LS138	+	8	16
352	SN74LS138	+	8	16
353	SN74LS138	+	8	16
354	SN74LS138	+	8	16
355	SN74LS138	+	8	16
356	SN74LS138	+	8	16
357	SN74LS138	+	8	16
358	SN74LS138	+	8	16
359	SN74LS138	+	8	16
360	SN74LS138	+	8	16
361	SN74LS138	+	8	16
362	SN74LS138	+	8	16
363	SN74LS138	+	8	16
364	SN74LS138	+	8	16
365	SN74LS138	+	8	16
366	SN74LS138	+	8	16
367	SN74LS138	+	8	16
368	SN74LS138	+	8	16
369	SN74LS138	+	8	16
370	SN74LS138	+	8	16
371	SN74LS138	+	8	16
372	SN74LS138	+	8	16
373	SN74LS138	+	8	16
374	SN74LS138	+	8	16
375	SN74LS138	+	8	16
376	SN74LS138	+	8	16
377	SN74LS138	+	8	16
378	SN74LS138	+	8	16
379	SN74LS138	+	8	16
380	SN74LS138	+	8	16
381	SN74LS138	+	8	16
382	SN74LS138	+	8	16
383	SN74LS138	+	8	16
384	SN74LS138	+	8	16
385	SN74LS138	+	8	16
386	SN74LS138	+	8	16
387	SN74LS138	+	8	16
388	SN74LS138	+	8	16
389	SN74LS138	+	8	16
390	SN74LS138	+	8	16
391	SN74LS138	+	8	16
392	SN74LS138	+	8	16
393	SN74LS138	+	8	16
394	SN74LS138	+	8	16
395	SN74LS138	+	8	16
396	SN74LS138	+	8	16
397	SN74LS138	+	8	16
398	SN74LS138	+	8	16
399	SN74LS138	+	8	16
400	SN74LS138	+	8	16
401	SN74LS138	+	8	16
402	SN74LS138	+	8	16
403	SN74LS138	+	8	16
404	SN74LS138	+	8	16
405	SN74LS138	+	8	16
406	SN74LS138	+	8	16
407	SN74LS138	+	8	16
408	SN74LS138	+	8	16
409	SN74LS138	+	8	16
410	SN74LS138	+	8	16
411	SN74LS138	+	8	16
412	SN74LS138	+	8	16
413	SN74LS138	+	8	16
414	SN74LS138	+	8	16
415	SN74LS138	+	8	16
416	SN74LS138	+	8	16
417	SN74LS138	+	8	16
418	SN74LS138	+	8	16
419	SN74LS138	+	8	16
420	SN74LS138	+	8	16
421	SN74LS138	+	8	16
422	SN74LS138	+	8	16
423	SN74LS138	+	8	16
424	SN74LS138	+	8	16
425	SN74LS138	+	8	16
426	SN74LS138	+	8	16
427	SN74LS138	+	8	16
428	SN74LS138	+	8	16
429	SN74LS138	+	8	16
430	SN74LS138	+	8	16
431	SN74LS138	+	8	16
432	SN74LS138	+	8	16
433	SN74LS138	+	8	16
434	SN74LS138	+	8	16
435	SN74LS138	+	8	16
436	SN74LS138	+	8	16
437	SN74LS138	+	8	16
438	SN74LS138	+	8	16
439	SN74LS138	+	8	16
440	SN74LS138	+	8	16
441	SN74LS138	+	8	16
442	SN74LS138	+	8	16
443	SN74LS138	+	8	16
444	SN74LS138	+	8	16
445	SN74LS138	+	8	16
446	SN74LS138	+	8	16
447	SN74LS138	+	8	16
448	SN74LS138	+	8	16
449	SN74LS138	+	8	16
450	SN74LS138	+	8	16
451	SN74LS138	+	8	16
452	SN74LS138	+	8	16
453	SN74LS138	+	8	16
454	SN74LS138	+	8	16
455	SN74LS138	+	8	16
456	SN74LS138	+	8	16
457	SN74LS138	+	8	16
458	SN74LS138	+	8	16
459	SN74LS138	+	8	16
460	SN74LS138	+	8	16
461	SN74LS138	+	8	16
462	SN74LS138	+	8	16
463	SN74LS138	+	8	16
464	SN74LS138	+	8	16
465	SN74LS138	+	8	16
466	SN74LS138	+	8	16
467	SN74LS138	+	8	16
468	SN74LS138	+	8	16
469	SN74LS138	+	8	16
470	SN74LS138	+	8	16
471	SN74LS138	+	8	16
472	SN74LS138	+	8	16
473	SN74LS138	+	8	16
474	SN74LS138	+	8	16
475	SN74LS138	+	8	16
476	SN74LS138	+	8	16
477	SN74LS138	+	8	16
478	SN74LS138	+	8	16
479	SN74LS138	+	8	16
480	SN74LS138	+	8	16
481	SN74LS138	+	8	16
482	SN74LS138	+	8	16
483	SN74LS138	+	8	16
484	SN74LS138	+	8	16
485	SN74LS138	+	8	16
486	SN74LS138	+	8	16
487	SN74LS138	+	8	16
488	SN74LS138	+	8	16
489	SN74LS138	+	8	16
490	SN74LS138	+	8	16
491	SN74LS138	+	8	16
492	SN74LS138	+	8	16
493	SN74LS138	+	8	16
494	SN74LS138	+	8	16
495	SN74LS138	+	8	16
496	SN74LS138	+	8	16
497	SN74LS138	+	8	16
498	SN74LS138	+	8	16
499	SN74LS138	+	8	16
500	SN74LS138	+	8	16

Fig. 44
Unit 2, digital frequency synthesis (DFS)

**CODING SYSTEM OF FAILURE REPORTING FOR QUALITY
ASSESSMENT OF T & M INSTRUMENTS
(excl. potentiometric recorders)**

The information contents of the coded failure description is necessary for our computerized processing of quality data.

Since the reporting of repair and maintenance routines must be complete and exact, we give you an example of a correctly filled-out PHILIPS SERVICE Job sheet.

①	②	③	④
Country	Day Month Year	Typenumber /Version	Factory/Serial no.
3 2	1 5 0 4 7 5	O P M 3 2 6 0 0 2	D O 0 0 7 8 3

CODED FAILURE DESCRIPTION

⑤	⑥	⑦	⑧																																																			
Nature of call	Location	Component/sequence no.	Category																																																			
<input type="checkbox"/> Installation <input type="checkbox"/> Pre sale repair <input type="checkbox"/> Preventive maintenance <input checked="" type="checkbox"/> Corrective maintenance <input type="checkbox"/> Other	<table border="1" style="width: 100%; height: 100%; border-collapse: collapse;"> <tr><td> </td><td> </td><td> </td><td> </td></tr> <tr><td>0</td><td>0</td><td>2</td><td>1</td></tr> <tr><td> </td><td> </td><td> </td><td> </td></tr> <tr><td> </td><td> </td><td> </td><td> </td></tr> </table>					0	0	2	1									<table border="1" style="width: 100%; height: 100%; border-collapse: collapse;"> <tr><td>T</td><td>S</td><td>0</td><td>6</td><td>0</td><td>7</td></tr> <tr><td>R</td><td>0</td><td>0</td><td>6</td><td>3</td><td>1</td></tr> <tr><td>9</td><td>9</td><td>0</td><td>0</td><td>0</td><td>1</td></tr> <tr><td> </td><td> </td><td> </td><td> </td><td> </td><td> </td></tr> <tr><td> </td><td> </td><td> </td><td> </td><td> </td><td> </td></tr> </table>	T	S	0	6	0	7	R	0	0	6	3	1	9	9	0	0	0	1													<table border="1" style="width: 100%; height: 100%; border-collapse: collapse;"> <tr><td>5</td></tr> <tr><td>2</td></tr> <tr><td>4</td></tr> <tr><td> </td></tr> <tr><td> </td></tr> </table>	5	2	4		
0	0	2	1																																																			
T	S	0	6	0	7																																																	
R	0	0	6	3	1																																																	
9	9	0	0	0	1																																																	
5																																																						
2																																																						
4																																																						
			Job completed <input checked="" type="checkbox"/> Working time ⑧ <table border="1" style="width: 100%; border-collapse: collapse;"> <tr><td> </td><td> </td><td>1</td><td>2</td></tr> </table> Hrs			1	2																																															
		1	2																																																			

Detailed description of the information to be entered in the various boxes:

①Country: 3 2 = Switzerland

②Day Month Year 1 5 0 4 7 5 = 15 April 1975

③Type number/Version O P M 3 2 6 0 0 2 = Oscilloscope PM 3260, version 02 (in later oscilloscopes this number is placed in front of the serial no)

④Factory/Serial number D O 0 0 7 8 3 = DO 783 These data are mentioned on the type plate of the instrument

⑤ Nature of call: Enter a cross in the relevant box

⑥ Coded failure description

<p>Location</p> <table border="1" style="width: 100%; height: 20px; border-collapse: collapse;"> <tr><td> </td><td> </td><td> </td><td> </td></tr> </table> <p>These four boxes are used to isolate the problem area. Write the code of the part in which the fault occurs, e.g. unit no or mechanical item no of this part (refer to 'PARTS LISTS' in the manual). Example: 0001 for Unit 1 000A for Unit A 0075 for item 75 If units are not numbered, do not fill in the four boxes; see Example Job sheet.</p>					<p>Component/sequence no.</p> <table border="1" style="width: 100%; height: 20px; border-collapse: collapse;"> <tr><td> </td><td> </td><td> </td><td> </td><td> </td><td> </td></tr> </table> <p>These six boxes are intended to pinpoint the faulty component. A. Enter the component designation as used in the circuit diagram. If the designation is alfa-numeric, the letters must be written (starting from the left) in the two left-hand boxes and the figures must be written (in such a way that the last digit occupies the right-most box) in the four right-hand boxes. B. Parts not identified in the circuit diagram: 990000 Unknown/Not applicable 990001 Cabinet or rack (text plate, emblem, grip, rail, graticule, etc.) 990002 Knob (incl. dial knob, cap, etc.) 990003 Probe (only if attached to instrument) 990004 Leads and associated plugs 990005 Holder (valve, transistor, fuse, board, etc.) 990006 Complete unit (p.w. board, h.t. unit, etc.) 990007 Accessory (only those without type number) 990008 Documentation (manual, supplement, etc.) 990009 Foreign object 990099 Miscellaneous</p>							<p>Category</p> <table border="1" style="width: 100%; height: 20px; border-collapse: collapse;"> <tr><td> </td></tr> </table> <ul style="list-style-type: none"> 0 Unknown, not applicable (fault not present, intermittent or disappeared) 1 Software error 2 Readjustment 3 Electrical repair (wiring, solder joint, etc.) 4 Mechanical repair (polishing, filing, remachining, etc.) 5 Replacement (of transistor, resistor, etc.) 6 Cleaning and/or lubrication 7 Operator error 8 Missing items (on pre-sale test) 9 Environmental requirements are not met 	

⑦ Job completed: Enter a cross when the job has been completed.

⑧ Working time: Enter the total number of working hours in connection with the job (excluding travelling, waiting time, etc.), using the last box for tenths of hours.

		1	2
--	--	---	---

 = 1,2 working hours (1 h 12 min.)