

REGULATED DC POWER SUPPLY

PE 1642 (9415 016 42001)

PE 1644 (9415 016 44001)

PE 1646 (9415 016 46001)

PE 1648 (9415 016 48001)

OPERATING MANUAL — Page 2

BEDIENUNGSANLEITUNG — Seite 10

NOTICE D'EMPLOI — page 18



4822 872 40455

870518



PHILIPS

© PHILIPS - INDUSTRIAL & ELECTRO-ACOUSTIC SYSTEMS DIVISION - EINDHOVEN - THE NETHERLANDS 1987
Printed in Belgium.

CONTENTS	2
LIST OF FIGURES	2
ABBREVIATIONS	2

GENERAL INFORMATION	3
UNPACKING	
VISUAL INSPECTION	
CLAIMS	
NOTE	

GENERAL	3
---------	---

1.	INTRODUCTION	
2.	CHARACTERISTICS	
2.1.	ELECTRICAL DATA	
2.1.1.	GENERAL	
2.1.2.	INPUT	
2.1.3.	OUTPUT	
2.1.4.	OUTPUT EFFECTS	
2.1.4.1.	AS VOLTAGE STABILIZER	
2.1.4.2.	AS CURRENT STABILIZER	4
2.1.5.	PROTECTION	
2.2.	ENVIRONMENTAL DATA	
2.2.1.	ENVIRONMENTAL TESTS	
2.3.	MECHANICAL DATA	
2.3.1.	MOUNTING	
2.4.	ACCESSORIES	

DIRECTIONS FOR USE	4
--------------------	---

3.	INSTALLATION	
3.1.	INITIAL INSPECTION	
3.2.	MOUNTING INSTRUCTIONS	
3.2.1.	RACK-MOUNTING	
3.2.2.	TABLE-MOUNTING	5
3.3.	DISMANTLING	

4.	CONNECTIONS	
4.1.	MAINS	
4.2.	EARTHING	
4.3.	OUTPUT	

5.	OPERATING INSTRUCTIONS	
5.1.	CONTROLS, INDICATORS, TERMINALS	
5.2.	SENSING	
5.2.1.	LOCAL SENSING	
5.2.2.	REMOTE SENSING	
5.3.	SERIES AND PARALLEL CONNECTIONS	6
5.3.1.	SERIES CONNECTIONS WITHOUT AND WITH "MASTER-SLAVE" SYSTEM	

5.3.1.1.	WITHOUT "MASTER-SLAVE" SYSTEM	
5.3.1.2.	WITH "MASTER-SLAVE" SYSTEM	
5.3.2.	PARALLEL OPERATION, WITHOUT AND WITH "MASTER-SLAVE" SYSTEM	
5.3.2.1.	WITHOUT "MASTER-SLAVE" SYSTEM	
5.3.2.2.	WITH "MASTER-SLAVE" SYSTEM	
5.4.	EXTERNAL CONTROLS : REMOTE ON/OFF AND REMOTE OFF	

5.5.	ADJUSTMENTS	7
5.5.1.	GENERAL	
5.5.2.	MAINS	
5.5.3.	OUTPUT	
5.5.3.1.	OUTPUT VOLTAGE U_o	
5.5.3.2.	OUTPUT CURRENT I_o	
5.5.3.3.	O.V.P.	
5.5.4.	PROGRAMMING (output voltage and current)	
5.5.4.1.	PROGRAMMING WITH PE 1367/00	
5.6.	OPTIONS : INTERNAL OR EXTERNAL CROWBAR	8
5.6.1.	COMBINED FACILITIES	

6.	SERVICING	
6.1.	FUSE REPLACEMENT	

7.	WARNING SYMBOLS	
----	-----------------	--

LIST OF FIGURES

FIG.

60	Output characteristic I_o/U_o	26
61	Output characteristic U_o/t	26
62	PE 1648/00 characteristic I_o/U_o	27
63	PE 1648/00 characteristic I_o/U_o	27
64	PE 1648/00 Recovery time	27
65	PE 1648/00 Recovery time	27
100	Front view	28
110	Rear view	28
130	Top view	29
224	Local sensing	30
230	Remote sensing	30
241	Series connection ("Master-Slave" system)	30
246	Parallel operation ("Master-Slave" system)	30
260	Remote OFF	30
261	Remote ON-OFF	30
274	U_o programming (with R_p)	30
279	U_o programming (with U_p)	30
284	I_o programming (with R_p)	30
289	I_o programming (with U_p)	30
294	Combined facilities	30
295	Combined facilities	30
310	Unit A1 (scrap view)	29
330	PE 1642 : Unit A3 (scrap view)	29
331	PE 1644 : Unit A3 (scrap view)	29
560	T27 Auxiliary transformer	29
800	PE 1367/00 Block diagram	31
801	PE 1367/00 Block diagram channel 1	31
802	PE 1367/00 Connection to PE 1642-44-46-48/00	31
1000	PE 1642/00 Circuit diagram	32
1001	PE 1644/00 Circuit diagram	33
1002	PE 1646/00 Circuit diagram	34
1003	PE 1648/00 Circuit diagram	35

ABBREVIATIONS

BW	Bandwidth
f_m	Mains frequency
G	External supply
I_m	Mains current
I_o	Output current
M-S	Master-Slave
OVP	Overvoltage protection
PARD	Periodic and random deviation
P_o	Output power
p-p	Peak-to-peak value
RH	Relative humidity
r.m.s.	Root mean square value
R_p	Programming resistor
U_m	Mains voltage
U_o	Output voltage
U_p	Programming voltage



PHILIPS

Service Information

Advanced Automation Systems
Audio-communications
Broadcast Equipment
Electronic Security & Recording Systems
Industrial Automation
Scientific & Analytical Equipment
Test and Measurement

**Industrial &
Electro-acoustic
Systems
Division**

860911

POWER SUPPLIES

SERVICE INFORMATION N° 106

PE 1642 - 1644 - 1646 - 1648 : 400 W
BENCH-MODELS POWER SUPPLIES

SERVICE MANUAL : 9499 165 00611 OR 4822 872 45003

CONC. : INFORMATIONS ABOUT THE THREE DIFFERENT TYPES OF METERS USED IN THESE
POWER SUPPLIES

SERVICE INFORMATION

4822 872 48406

ANNEXE SERVICE INFORMATION N° 106

FRONT VIEW

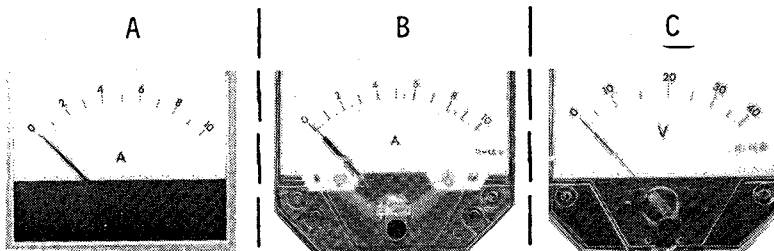

METER TYPES :

REAR VIEW

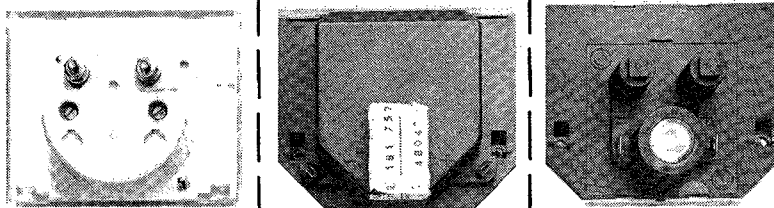

ORDERING NUMBERS

PE 1642/00

P1 : VOLTMETER 20 V :	5322 344 64106	5322 344 60007	5322 344 60074
P2 : AMMETER 20 A :	5322 344 64107	5322 344 60049	5322 344 60115
TEXT PLATES :	GREY : 5322 455 61004		
-----	BROWN : 5322 455 61024		

PE 1644/00

P1 : VOLTMETER 40 V :	5322 344 64105	5322 344 60014	5322 344 60075
P2 : AMMETER 10 A :	5322 344 64104	5322 344 60015	5322 344 60114
TEXT PLATES :	GREY : 5322 455 61001		
-----	BROWN : 5322 455 61022		

PE 1646/00

P1 : VOLTMETER 75 V :	5322 344 64119	5322 344 60011	5322 344 60076
P2 : AMMETER 6 A :	5322 344 64121	5322 344 60016	5322 344 64121
TEXT PLATES :	GREY : 5322 455 61003		
-----	BROWN : 5322 455 61023		

PE 1648/00

P1 : VOLTMETER 150V :	5322 344 64108	5322 344 60009	5322 344 60077
P2 : AMMETER 3 A :	5322 344 64109	5322 344 60008	5322 344 60113
TEXT PLATES :	GREY : 5322 455 61002		
-----	BROWN : 5322 455 61032		

NOTE : B and C meter types must be used with new front wall : 5322 447 90381

GENERAL INFORMATION

* Unpacking

On delivery, check the power supply as soon as possible to ascertain whether any damage has occurred in transit. Retain all packing materials until all items of the power supply have been accounted for and checked.

* Visual Inspection

Carry out a mechanical check on e.g. connectors, terminal blocks, external fuseholders and other enclosures. Check items for dents, chips or other signs of damage. Check if all accessories are present in accordance with the accessories list (see Section 2.4.)

* Claims

In the event of obvious damage or shortages, or if the safety of the power supply is suspect, a claim should be filed with the carrier immediately. A PHILIPS Sales or Service organisation should also be notified in order to facilitate the repair of the instrument.

* Note

Do not connect the power supply to the mains until it has been checked by a skilled technician.

GENERAL

1. INTRODUCTION

The PE 1642, PE 1644, PE 1646 and PE 1648 are 400 W stabilised d.c. power supplies, which provide maximum output when convection cooling is used and the ambient temperature is lower than 40°C.

The power supplies are intended for 19-inch rack-mounting but can be adapted for use as free-standing versions.

Optimum efficiency is obtained by means of a thyristor pre-regulator and the transistor series-regulator gives good control and stability with minimum ripple.

The output voltage, current and the overvoltage protection can be continuously adjusted.

Several instruments may be series or parallel connected. Other facilities include: remote sensing, "master-slave" series or parallel operation, remote ON-OFF, voltage and current programming, crowbar protection.

NOTE: The design of this power supply is subject to development and improvement. Consequently, this power supply may incorporate minor changes with respect to the information contained in this manual. Only figures with tolerances or limits can be considered as guaranteed data. Figures without tolerances are informative data, without guarantee.

2. CHARACTERISTICS

2.1. ELECTRICAL DATA

The values given in this section are valid within the rated range of operation (0°C to +40°C). On delivery, the supply is adjusted at an ambient temperature of 25°C, with convection cooling.

2.1.1. GENERAL

* Safety

In accordance with IEC 348, safety class 1.

* Dielectric strength test

For details, see Service Manual, Section 6.1.

* PE 1642-44-46-48/00 87.05.18

* Output terminals

Floating with respect to earth.

The voltage between any of the output terminals and earth may not exceed 250 V d.c. or a.c. (r.m.s.). The "+" or "-" (front or rear) may be earthed.

* Interference level

Input: in accordance with VDE 0875 N-level for r.f.i. transferred to the mains.

2.1.2. INPUT

U _m : 220 V ± 10 %		f _m : 50 - 60 Hz	
Type	Consumption	Inrush current max.	Efficiency (min.)
PE 1642/00	1.150 VA	40 A	62 %
PE 1644/00	950 VA	40 A	73 %
PE 1646/00	1.000 VA	40 A	79 %
PE 1648/00	975 VA	40 A	81 %

2.1.3. OUTPUT

TYPE PE /00	U _o (1)			I _o (1)		
	Coarse R1	Fine R2	Resolu- tion	Coarse R3	Fine R4	Resolu- tion
1642	0- 20 V	0-0,2 V	0,5 mV	0-20 A	0 - 0,6A	10 mA
1644	0- 40 V	0-0,4 V	1,0 mV	0-10 A	0 - 0,3A	5 mA
1646	0- 75 V	0-0,75 V	2,0 mV	0- 6 A	0 - 0,2A	3 mA
1648	0-150 V	0-1,5 V	4,0 mV	0- 3 A	0 - 0,1A	1,5 mA

(1) Continuously adjustable

2.1.4. OUTPUT EFFECTS (IEC 478-2)

2.1.4.1. AS VOLTAGE STABILIZER

Type PE /00	Source effect (U _m +10 % / -10 %)	Settling effect *	Load effect 0-100 % 100-0 %	Settling effect
1642	0,01 % - 0,5 mV *	0,01 % - 0,5mV	+/-10 mV	+/-10 mV
1644	0,01 % - 0,5 mV *	0,01 % - 0,5mV	+/-10 mV	+/-10 mV
1646	0,003% - 0,5 mV *	0,01 % - 1,5mV	+/-15 mV	+/-10 mV
1648	0,003% - 0,5 mV *	0,005% - 1,5mV	+/-15 mV	+/-10 mV

Type	Temperature coefficient (max.)	PARD (max.) mV p-p mV r.m.s.	
PE 1642/00	0,01 %/°K - 0,2 mV/°K *	16	1
PE 1644/00	0,005 %/°K - 0,2 mV/°K *	12	1
PE 1646/00	0,005 %/°K - 0,5 mV/°K *	20	1
PE 1648/00	0,005 %/°K - 1,5 mV/°K *	25	1

* Whichever is greater

Type	Transient recovery time I _o : 50 % - 100 % dI/dt = 1 A/us (max.)	Dynamic impedance (Ohm) (max.) (**)			
		1 kHz	10 kHz	100 kHz	250 kHz
PE 1642/00	25 us	0,01	0,04	0,1	0,2
PE 1644/00	50 us	0,02	0,06	0,1	0,2
PE 1646/00	50 us	0,01	0,07	0,12	0,15
PE 1648/00	25 us	0,01	0,15	0,15	0,15

** Sinusoidal variation (I_o : 80 % - 100 %)

2.1.4.2. AS CURRENT STABILIZER

Type PE /00	Source effect $U_m \pm 10\%$	Settling effect	Load effect Fig. 60	Settling effect	Temperature coefficient	Ripple current mA rms (max)
1642	± 4 mA	± 2 mA	± 2 mA	± 3 mA	2 mA/°K	10
1644	± 2 mA	± 1 mA	± 2 mA	± 1 mA	1 mA/°K	5
1646	$\pm 1,5$ mA	± 1 mA	± 3 mA	± 1 mA	0,5 mA/°K	4
1648	$\pm 0,5$ mA	$\pm 0,5$ mA	± 2 mA	± 1 mA	0,3 mA/°K	3

2.1.5. PROTECTION

General

- Adjustable constant current stabiliser
- Sense protection
- Reverse voltage protection
- Mains fuses

Type	Overvoltage protection (R5)		Crowbar	Overcurrent protection
	U_{min}	U_{max}		
PE 1642/00	0,3 V	21,5 V	Option	X
PE 1644/00	0,5 V	42 V	Option	-
PE 1646/00	1,0 V	77 V	-	X
PE 1648/00	1,5 V	152 V	-	X

2.2. ENVIRONMENTAL DATA

Details of these procedures are supplied on request by the PHILIPS Organisation in your country, or by PHILIPS INDUSTRIAL & ELECTRO-ACOUSTIC SYSTEMS DIVISION, EINDHOVEN, THE NETHERLANDS.

2.2.1. ENVIRONMENTAL TESTS

Performance tests, operating

Description	IEC-68
Cold test	2-1 Ad 2 h. (0°C)
Dry heat	2-2 Bd 2 h. (+40°C)

Tests for storage and transport

Description	IEC-68
Cold test	2-1 Ab 72 h. (-40°C)
Dry heat	2-2 Bd 96 h. (+70°C)
Vibration test	2-6 Fc
Bump test	2-29 Eb
Cyclic damp heat test	2-30 Db 21 d. (+25°C to +40°C) 95 % RH

2.3. MECHANICAL DATA

Height : 132 mm	147 mm (B) (Table model)
Width : 444 mm	444 mm
Depth : 315 mm	360 mm (B) (Table model)
Mass : 21 kg	27 kg (with packaging)

2.3.1. MOUNTING

Table model (B)
Rackmounted

2.4. ACCESSORIES

OPERATING MANUAL

2 feet, 2 self-tapping screws for fixing
Mains cable

OPTIONAL

PE 1373/02 Rack adaptor for 2 fans
PE 1374/02 Fan (110 V a.c.)
Thyristor BTW 40 - 400 R (5322 130 24067)
PE 1367/00 Programmer, see 5.5.4.1.

DIRECTIONS FOR USE

3. INSTALLATION

This section deals with the preparation of the power supply for use. For mounting details concerning ventilation and ambient temperature conditions, refer to Section 2.2. "Environmental data" and Section 2.4. "Accessories". The power supplies are intended for 19-inch rack-mounting and are provided with two brackets on the front plate.

WARNING : Before connecting the power supply to the mains, the safety measures must be thoroughly understood and observed.

Bear in mind that all adjustments, replacements, repairs, etc. shall be carried out by a skilled person, who is aware of the hazards involved.

3.1. INITIAL INSPECTION

NOTE

THIS apparatus has been designed according to IEC publication 348, Class I and has been supplied in a safe condition. The present operating manual contains information and warnings which shall be followed by the purchaser to ensure safe operation and to retain the power supply in safe condition.

On delivery, the supply is connected for $U_m = 220$ V and for local sensing ; for the connections on X 4, see Fig. 224.

3.2. MOUNTING INSTRUCTIONS

3.2.1. RACK-MOUNTING

- It is recommended that a distance of 1 E (44 mm) is left between the instrument and adjacent instruments above or below it (the ambient temperature is defined as that measured 20 mm below the unit).
- For rack-mounting, the holes of the top and bottom plates will remain free to ensure adequate cooling of the instrument.
- The supply is fixed to the 19-inch frame by means of four M5 screws through the holes in the brackets (see Fig. 100).
- To maintain the ambient temperature of the instrument in the rack below 40°C, Philips fan unit is recommended (mounting, height : 1 E, width : 19 inch) PE 1373/02 and one or two fans (PE 1374/02) : one or two fans for a 110 V a.c. mains and two series-connected fans for a 220 V a.c. mains.

3.2.2. TABLE-MOUNTING

For installation as a free-standing version, proceed as follows :

- slide the two feet delivered into the slots B (see Fig. 110) and then retain the feet using the two self-tapping screws.
- remove the brackets for 19-inch mounting : unscrew the four M4 x 20 screws (two per hand-grip), accessible via slots in the side panels.

3.3. DISMANTLING

The instrument shall be disconnected from all voltage sources before any adjustment, replacement or maintenance and repair. Bear in mind that capacitors inside the instrument may still be charged, even if the instrument has been disconnected from all voltage sources. Subsequently, if any adjustment, maintenance or repair of the opened instrument under voltage conditions is inevitable, it shall be carried out only by a skilled person who is aware of the danger involved.

- The top and bottom cover-plate can be slid out after first removing five screws M2,5 x 4.
- The rear cover plate (see Fig. 110) can be removed after withdrawing the two screws M3 x 6.

4. CONNECTIONS

NOTE

During operation, the connections on the terminal block X 4 must not be interrupted, otherwise the power supply could be damaged.

4.1. MAINS

See Fig. 110

The power supply must be connected to the mains voltage (a.c.) through the terminal block X 5 :

X 5 (2) and X 5 (3).

The cross-section of the input wires must be of adequate current-carrying capacity (also dependent on the distance between the source and the supply). Bear in mind that the cross-section of the earth conductor must be at least equal to the cross-section of the mains conductors and in accordance with the local safety regulations (e.g. colour, section etc ...).

4.2. EARTHING

See Fig. 110

WARNING : Before any connection is made to a voltage source, the protective earth terminal shall be connected to a protective conductor.

* If a three-core mains cable with mains plug is used, the mains plug shall be inserted into a socket outlet provided with a protective earth contact. The protective action shall not be negated by the use of an extension lead without a protective conductor (see also Section 7).

WARNING : When a power supply is brought from a cold to a warm environment, condensation may cause a hazardous condition ; ensure therefore that the earthing requirements are strictly adhered to.

To this end, the power supply must be connected to a protective earth in the following way :

- with the earthing screw X6  (M4) adjacent to X5.

4.3. OUTPUT

The load may be connected either on the front panel or at the rear of the supply (see Fig. 100 and 110).

	-	+	⊥
Front	X1	X2	X3
Rear	X4 (3)	X4 (5)	X4 (4)

The load can be earthed via X3 or X4 (4).

NOTE : The output effects given in Section 2.1.4. are valid only if the load is connected either to the front or to the rear terminals ; the output voltage is measured on the sense terminals X4 (9) "-" and X4 (10) "+".

5. OPERATING INSTRUCTIONS

NOTE : During operation, the connection on the terminal block X4 (and between the terminals block X4 of the master and slave instruments) must not be interrupted, otherwise the power supply could be damaged.

5.1. CONTROLS, INDICATORS, TERMINALS

See Fig. 100 and 110

	Item	Marking	Description
Front	R1	COARSE	Coarse adjustment of U_0
	R2	FINE	Fine adjustment of U_0
	R3	COARSE	Coarse adjustment of I_0
	R4	FINE	Fine adjustment of I_0
	R5	ADJUST	Adjustment of OVP trip-voltage
	V1, V2		Led (green) : constant voltage-constant current
	V3	FAILURE	Led (red) : OVP is operating
	P1, P2	V A	Voltmeter (U_0) Ammeter (I_0)
	X1	-	Negative output terminal
	X2	+	Positive output terminal
Rear	X3		Terminal for earthing the output
	S1	POWER ON	Switching the supply ON-OFF
	F1, F2	8A, 16A	Mains fuses (delayed)
	X4 (1 to 20)		20-pole terminal block, connection of the different facilities
	X5 (1 to 3)		3-pole terminal block : 1, 2 mains / 3 earthing
	X6		Protective earth screw M 4

5.2. SENSING

5.2.1. LOCAL SENSING

See Fig. 224

On delivery, the power supply is connected for local sensing, load connected to the front-panel terminals (X1, X2) ; links X4 (10-11) and X4 (12-13).

NOTE : Bear in mind that if these links on X4 are incorrectly connected or interrupted, THE POWER SUPPLY WILL NOT START.

5.2.2. REMOTE SENSING

See Fig. 230

- When the load is at some distance from the power supply or if the output characteristics must be defined on the load, remote sensing can be usefully employed to compensate for losses in the load lines.
- Remove the links X4 (10-11) and X4 (12-13) as for local sensing.
- Connect the + sense wire X4 (10) to the "+" of the load and the - sense wire X4 (9) to the "-" of the load.
- The sense wires should be twisted and screened if possible. The screen should be earthed at one end only and should not be used as one of the sensing conductors.

The output voltage goes to zero (OVP operates) if

- the load lines are interrupted
- sense lines or loadlines are inverted
- the voltage loss in one of the load lines exceeds 0,5 V

The voltage on the load is equal to, or less than, the adjusted voltage when the sense lines are interrupted. For optimum ripple rejection and dynamic response, a capacitor can be connected across the load :

PE 1642/00 : 2200 μ F - 40 V
 PE 1644/00 : 1000 μ F - 63 V
 PE 1646/00 : 560 μ F - 100 V
 PE 1648/00 : 270 μ F - 160 V

NOTE : The front-panel voltmeter P1 indicates the voltage on the output terminals, which is not always that across the load.

5.3. SERIES AND PARALLEL CONNECTIONS

5.3.1. SERIES CONNECTIONS WITHOUT AND WITH «MASTER-SLAVE» SYSTEM

Instruments of the same type may be series connected until the maximum permissible voltage of 250 V d.c. between any output terminal and earth is reached.

WARNING : Only one of the "+" or "-" terminals may be connected to earth.

When one of the output terminals "+" or "-" is connected to earth \perp , X3 or X4 (4) the adjusted output voltage is present between the unearthed output terminal and instrument chassis.

Instruments may be connected in series in two ways ; without and with the Master-Slave system.

5.3.1.1. WITHOUT «MASTER-SLAVE» SYSTEM

Connect the "+" output X2 or X4 (5) of the first instrument with the "-" output X1 or X4 (3) of the second instrument, and so on. The voltage on the load will then be the sum of the individually adjusted output voltages, the current through the load is determined by the supply with the lowest current limitation.

If the output voltage of any instrument exceeds its adjusted OVP trip voltage, that instrument contributes no power to the load, the total output voltage is reduced by an amount equal to that of the tripped supply while current is still flowing through the load.

5.3.1.2. WITH «MASTER-SLAVE» SYSTEM

NOTE : Only for supplies of the same type.

Action : Top plate removed (3.3.)
 Remove R202 (Fig. 310)
 Fit : R202, new value, (MR25 1 %) (Fig. 310)

Description :

Type PE	Old value	New value	Code
1642/00	1,96 kOhm	3,92 kOhm	5322 116 54591
1644/00	953 Ohm	3,83 kOhm	5322 116 54589
1646/00	464 Ohm	3,48 kOhm	5322 116 54585
1648/00	249 Ohm	3,65 kOhm	5322 116 54587

Connect : R (MR25 : 1 %) (Fig. 241)

Type PE	Value	Code
1642/00	10,0 kOhm	5322 116 54619
1644/00	30,1 kOhm	5322 116 54655
1646/00	64,9 kOhm	5322 116 50514
1648/00	140 kOhm	5322 116 54259

Connect : X1, X2 (or X4) (Fig. 241)
 Set : R3, R4 "Slave" : to maximum
 : R3, R4 "Master" : adjustment of load current
 : R1, R2 "Master" : U_0 (summation voltage) (1)
 : R1, R2 "Slave" inoperative
 : R5 "Master and Slave" : OVP
 OVP "Master" ON : total $U_0 = 0$ V
 OVP "Slave" ON U_0 reduced
 I_0 remains

Switch-on (with S1)
 Always switch the "Slave" power supplies ON before the "Master".

(1): - every supply is adjusted to the same voltage

5.3.2. PARALLEL OPERATION, WITHOUT AND WITH «MASTER-SLAVE» SYSTEM

Parallel connections of instruments of the same type and without internal or external crowbar is unlimited and can be achieved in two ways : without and with Master-Slave system.

5.3.2.1. WITHOUT «MASTER-SLAVE» SYSTEM

See Fig. 100

Connect : All "-" output terminals X1 or X4 (3)
 All "+" output terminals X2 or X4 (5)

Set : R1, R2 (each supply to the same value)
 U_0 (no load) = highest value
 U_0 (full load) = lowest value
 R3, R4 (of each supply)
 I_0 = summation of all currents
 R5 (of each supply)

If any OVP operates, U_0 and I_0 are determined by the remaining supplies.

5.3.2.2. WITH «MASTER-SLAVE» SYSTEM

See Fig. 246

Connect : X1, X2 (or X4), and X4

Set (Fig. 100)
 R1, R2 "Slave" = $1,02 \times U_0$ (max.)
 R1, R2 "Master" = U_0
 R3, R4 "Master"

I_0 of each supply is determined by R3, R4 of the "Master".
 R3, R4 "Slave" inoperative
 R5 of each supply
 I_0 of each supply is determined by R3, R4 of the "MASTER"

If one OVP operates, $U_0 = 0$ V

Switch-on (S1)
 Always switch the "Slave" power supplies ON before the "Master".

5.4. EXTERNAL CONTROLS: REMOTE ON/OFF AND REMOTE OFF

* REMOTE ON-OFF (Fig. 261)

Connect
 Contact S2 between X4 (17) and X4 (20)
 Requirements : contact S2 : current min. 1 mA
 voltage min. 10 V

Action	Description
S2 open	U_0 (R1, R2)
S2 closed	$U_0 = 0$ V
S2 open	U_0 (R1, R2)

* REMOTE OFF (Fig. 260)

Connect
 External voltage source G1 (via a diode e.g. BAW 62)
 Requirements : diode current min. 1 mA
 reverse voltage min. 20 V
 source (G1) current min. 1 mA
 voltage max. 12 V

Action : G1 max. 1,0 V
 U_0 (R1, R2)

Action : G1 min. 1,5 V / max. 12 V
 $U_0 = 0$ V
 U_0 remains 0 V (OVP operates)

Action : S1 OFF and G1 disconnected or max. 1 V

Action : S1 ON
 U_0 (R1, R2)

5.5. ADJUSTMENTS

5.5.1. GENERAL

WARNING : When changing the mains voltage, the marking of the modified components and the type plate must be suitably adapted.

NOTE : Bear in mind that capacitors inside the instrument may still be charged, even if the instrument has been disconnected from all voltages sources.

5.5.2. MAINS

On delivery, the supply is set to 220 V mains.

NOTE : In order to meet the safety requirements, the wires must be fixed to the solder tags of the transformer T26, T27 in such a way that, when the solder melts, they do not become detached.

- For other mains voltages, see the table below (see also Fig. 140 and 560) : remove the top and bottom plates (see 3.3.).

Mains Voltage U_m	Input connections		Points to interconnect				Fuses delayed F1-F2
	T26	T27	T26		T27		
110 V	5 9	N 4	2-7-8-9,	3-4-5	1-3,	2-4-5	16 A
127 V	5 10	N 6	2-7-8-9,	3-4-5	1-3,	2-4-5	16 A
220 V	5 9	N 4	2-3, 4-5,	7-8-9	2-3,	4-5	8 A
240 V	5 10	N 6	2-3, 4-5,	7-8-9	2-3,	4-5	8 A

5.5.3. OUTPUT

5.5.3.1. OUTPUT VOLTAGE U_o

See Fig. 100 & Sec. 2.1.3.

5.5.3.2. OUTPUT CURRENT I_o

See Fig. 100 & Sec. 2.1.3.

The output current can be adjusted by short circuiting the output terminals. It is recommended to first set a low value of output voltage.

NOTE for PE 1648/00

If the instrument works as a constant current source the output voltage (U_o) varies due to load variations.

At fast (higher than 500 V/s) drops of U_o , it is possible that the output current (I_o) could be lower than the adjusted value during a short time.

When for example $U_o = 150$ V and $I_o = 3$ A there must be a drop higher than 50 V (see Fig. 62) with a rate higher than 500 V/s for the I_o to be lower than the adjusted I_o during 0,5 s (see Fig. 64) at maximum.

At $U_o = 150$ V and $I_o = 2$ A, the drop must be higher than 90 V and at $U_o = 150$ V and $I_o = 1$ A, higher than 130 V. Figure 63 shows the voltage drop that must occur at a U_o of 75 V in the constant range for the I_o (see Fig. 65) to be lower than the adjusted I_o .

If the above-mentioned phenomenon occurs, V2 (current-source indication) extinguishes and V3 "FAILURE" (indication O.V.P.) lights up.

5.5.3.3. O.V.P.

See Fig. 100 and Section 2.1.5.

Adjustable with R5 (screwdriver adjustment).

V3 : ON when O.V.P. is operating.

To set O.V.P. turn R5 completely clockwise. Switch on and turn voltage control to indicate O.V.P. level required.

Turn R5 anti-clockwise until "FAILURE" is lit (i.e. O.V.P. operates).

When the O.V.P. operates (indicated by V3) then the output voltage drops to 0 V. Switch OFF the instrument, turn R1 to the left, switch ON and adjust the required output voltage with R1 and R2.

5.5.4. PROGRAMMING (output voltage and current)

The output voltage and current can be controlled externally, either by means of a resistor or by a voltage source. When external programming is used, the following provisions apply : the output stability is dependent upon the stability of the external control elements and the overvoltage protection must be adjusted according to the maximum output voltage.

To prevent additional ripple, the wires to the programming device should be twisted and screened.

Type PE /00	U_o programming	
	with resistor R_p max. 10 kOhm 0,1W (1) Fig. 274	with voltage U_p max. 10 V 1 mA (2) Fig. 279
1642	2 V per 1 kOhm	2 V per 1 V
1644	4 V per 1 kOhm	4 V per 1 V
1646	7,5 V per 1 kOhm	7,5 V per 1 V
1648	15 V per 1 kOhm	15 V per 1 V

Type PE /00	I_o programming (3) (4)	
	with resistor R_p max. 1 kOhm 0,1W Fig. 284	with voltage U_p max. 0,5 V 0,5 mA Fig. 289
1642	2 A per 100 Ohm	1 A per 25 mV
1644	1 A per 100 Ohm	1 A per 50 mV
1646	1 A per 167 Ohm	1 A per 83 mV
1648	1 A per 333 Ohm	1 A per 166 mV

(1) - the values are only valid when R1 and R2 are set to give the nominal output voltage before programming (R1 and R2 remain operative).

- programming is also possible between 0 V and the output voltage adjusted by R1 and R2 without programming, programming is linear for R_p between 0 and 10 kOhm.

(2) R1 and R2 inoperative ;

U_o : internal resistance max. 100 Ohm.

(3) R3 and R4 inoperative

(4) - for PE 1642-44-46 : if the connection to the external programming device is inadvertently disconnected, the current limiting will be inoperative.

- for PE 1648 : the instrument overcurrent protection facility operates for inadvertent disconnection of the external programming device

5.5.4.1. PROGRAMMING WITH PE 1367/00

See Fig. 800, 801, 802

SPECIFICATIONS PE 1367/00

INPUT : 220 Va.c. (110 V - 120 V - 240 V)

OUTPUT :

Output voltage

- high range unipolar mode : 0 V ... 10 V ;

bipolar mode :- 10 V ... + 10 V ;

- low range unipolar mode : 0 V ... 1 V ;

bipolar mode :- 1 V ... + 1 V

Resolution : unipolar mode bipolar mode

high range 10 mV 20 mV

low range 1 mV 2 mV

Output current : unipolar and bipolar : 10 mA

Output impedance (d.c.) : max 0,1 Ohm

Linearity error : $\pm 1/2$ LSB (least significant bit)

Zero adjust : Plus or minus 500 mV

Full scale adjust : Plus or minus 5 %

Programming speed : Typ. 1 μ sec/volt (typical)

Number of channels : 2
 Galvanic isolation : 1.000 V d.c.
 Interface functions : AH1, L1, SH1, DC1, SR1
 Programming modes : 2 (% , AUTO)
 Calibration : "Off line" possible
 Current sink : for channel 1
 Temperature coefficient : 150 ppm/°K max.

ACCESSORIES : Adapter IEC-IEEE Bus : PM 9483
 Cable IEC 1 m : PM 9480
 Cable IEC 1 m : PM 9481

5.6. OPTIONS: INTERNAL OR EXTERNAL CROWBAR (ONLY FOR PE 1642/00 AND PE 1644/00)

When the output voltage reaches the adjusted trip voltage, the thyristor pre-regulation is blocked. The power that is at this instant stored in the output capacitor is discharged into the load. To prevent the instantaneous power being dissipated in the load, the output can be short-circuited by a thyristor (crowbar action).

After operation of the O.V.P., the output voltage is only obtainable after switching the instrument OFF and then ON again.

Requirements :

- minimum OVP trip voltage : 4 V
- maximum delivered control current : 120 mA
- thyristor BTW 40-400 R code : 5322 130 24067

NOTE : When a thyristor BTW 40-400 R is used, the operating time, i.e. the interval during which the output voltage rises above and returns to the trip voltage, is typically 1,2 msec, with an overshoot lower than 130 mV.

OPTION : INTERNAL / Section 3.3.		PE 1642 Fig.330	PE 1644 Fig.331
Sequence	Comment		
Remove Unsolder	Top and bottom plate R50 from V50 (C) to C27 (+) V50 (B)	X X X V50 (E) V67 (A)	X X X V50 (E) V64 (A)
Remove Mount	V50 (with its insulation) Crowbar thyristor, (insulated from cooling unit) See NOTE 1	X X	X X
Solder	From thyristor to G wire for V50(B) 2 A V67(K) (min.0,75mm ²) K (min.0,75mm)	X X X V67 (A)	X X X V64 (A)
Replace	Top and bottom plate	X	X
OPTION : EXTERNAL (2) / Section 3.3.			
Remove		Top plate	Bottom plate
Unsolder	V50 (B)	X	X
Insulate Replace	end of wire to V50 (B)	X Top plate	X Bottom plate
Connect (min. 2 0,75mm)	From thyristor to G X4 (7) A X4 (5) K X4 (3)		

- NOTE (1) : Insulation for BTW40-400R : 5322 255 40101
 (2) : Insulate the thyristor from its mounting or insulate the mounting unit if the thyristor is mounted directly on it.

5.6.1. COMBINED FACILITIES

The external connections (see Fig. 294) are given for combining : series connection in accordance with the master-slave system, remote voltage adjusting and remote ON/OFF.

In Fig. 295, the external connections are given for combining : parallel connection in accordance with the master-slave system, with crowbar protection, remote sensing, remote ON/OFF and remote voltage- and current control.

6. SERVICING

See WARNING B : Servicing by qualified person only !

For servicing, or if other technical information is required, please contact :
 your local Sale and Service address (back-side of the Operating Manual)
 OR
 the "Supply Centre".

PHILIPS INDUSTRIE s.a. Service Power Supplies Department Boulevard de l'Europe, 131 B-1301 WAVRE BELGIUM Telex : 59058 philwa b Tel : 10/41.65.11

Safety measures require that the instrument should first be put into its original state and that the spare parts are identical to the original components.

The instrument shall be disconnected from all voltage sources before any adjustment, replacement or maintenance and repair. Bear in mind that capacitors inside the instrument may still be charged, even if the instrument has been disconnected from all voltage sources. Consequently, if any adjustment, maintenance or repair of the opened instrument under voltage conditions is inevitable, it shall be carried out only by a skilled person who is aware of the danger involved.

The use of a mains-isolating transformer during service is necessary.

6.1. FUSE REPLACEMENT

This power supply is protected by the delayed-action fuses F1-F2 (8 A or 16 A, 250 V). For continued protection against fire and shock hazard, only fuses with the required rated current and of the specified type shall be used for replacement. The use of repaired fuses and short-circuiting of fuseholders shall be avoided. The instrument shall be disconnected from all voltage sources when a fuse is to be replaced. As the power supply is electronically protected against most faults, a blown fuse indicates a major defect. Before replacing the fuse, always check the electronic circuits. Code numbers of fuses :

F1-F2	110 V	8 A	delayed	250 V	5322 253 50036
		16 A	delayed	250 V	5322 253 54042

7. WARNING SYMBOLS



Protective earth terminal
 Any interruption of the protective conductor inside or outside the apparatus or disconnection of the protective earth terminal is likely to make the apparatus dangerous ; intentional interruption is prohibited.



For servicing or for other reasons, it is essential for the user to refer to the Operating Manual (Sections 3 and 6) and the Service Manual (Sections 4 and 6) in order to safeguard against damage to the instrument.

PE 1642-44-46-48/00: OUTPUT CHARACTERISTIC I_o/U_o

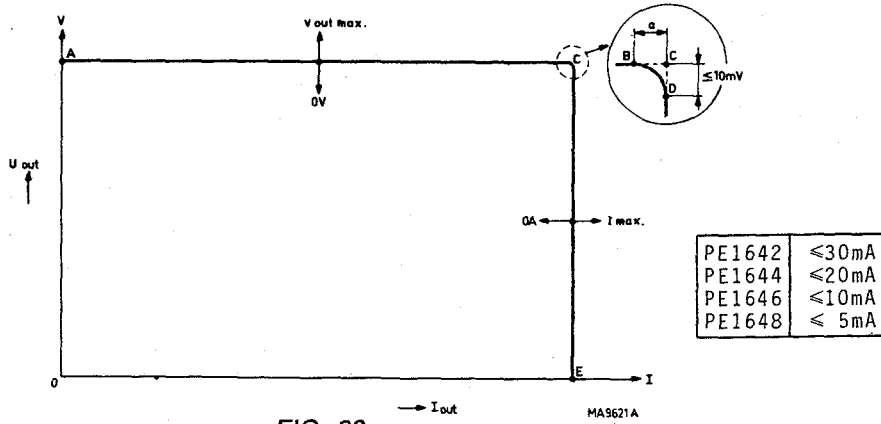

FIG. 60

PE 1642-44-46-48/00: OUTPUT CHARACTERISTICS U_o/t

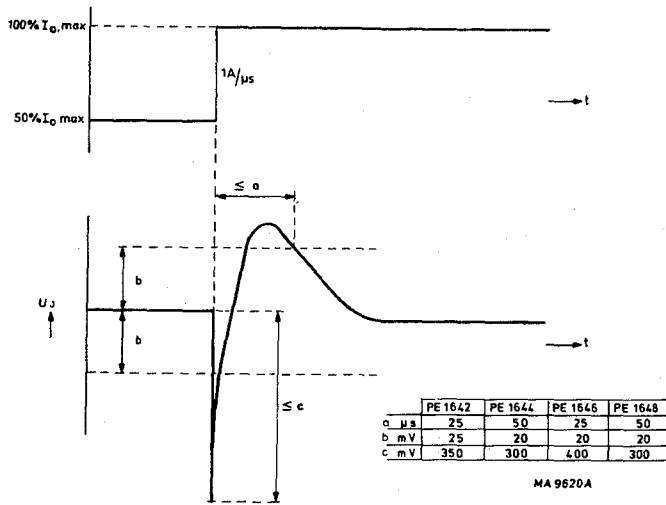

FIG. 61

PE 1648/00: OUTPUT CHARACTERISTICS

$I_o / U_o = 150 \text{ V}$

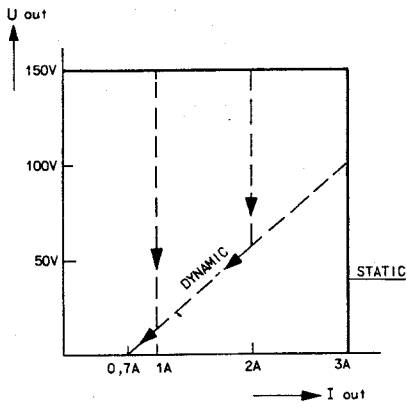

FIG. 62 WV598

$I_o / U_o = 75 \text{ V}$

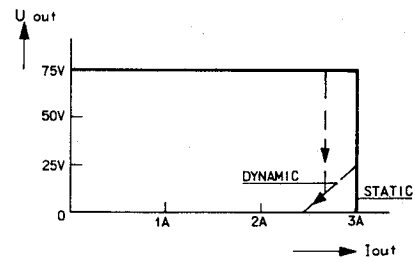

FIG. 63 WV599

RECOVERY TIME
 $U_o = 150 \text{ V}$

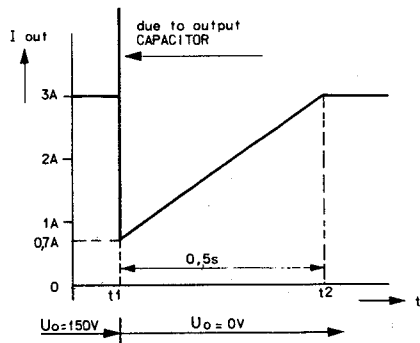

FIG. 64 WV600

RECOVERY TIME
 $U_o = 75 \text{ V}$

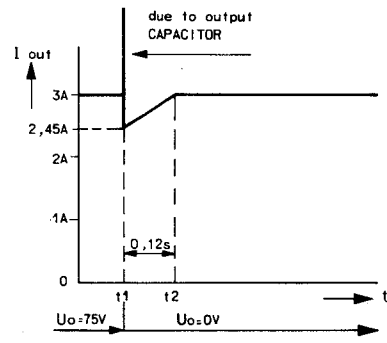

FIG. 65 WV601

PE 1642-44-46-48/00: FRONT VIEW

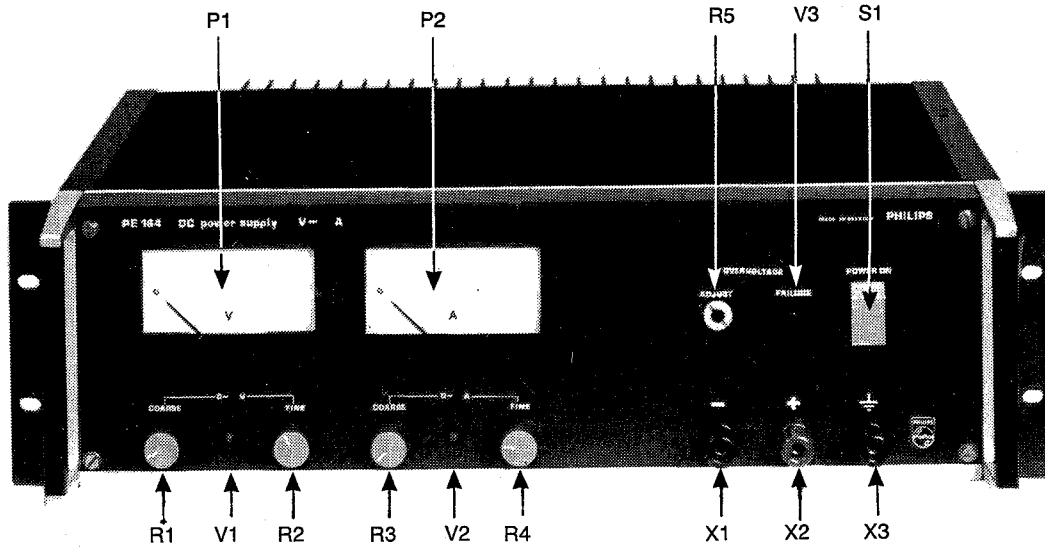

FIG. 100

PE 1642-44-46-48/00: REAR VIEW

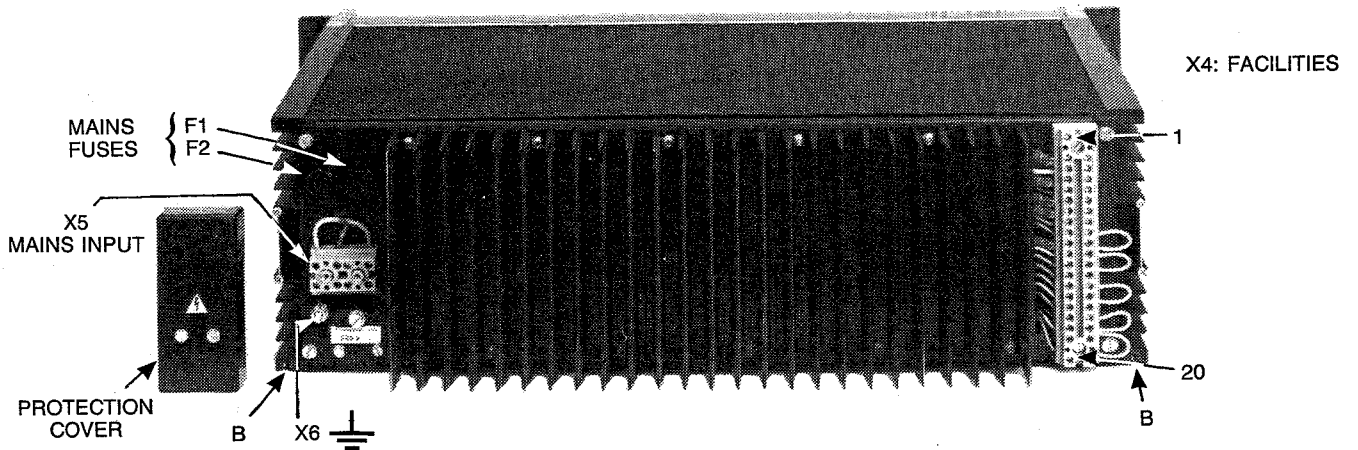

FIG. 110

PE 1642, 1644/00: TOP VIEW

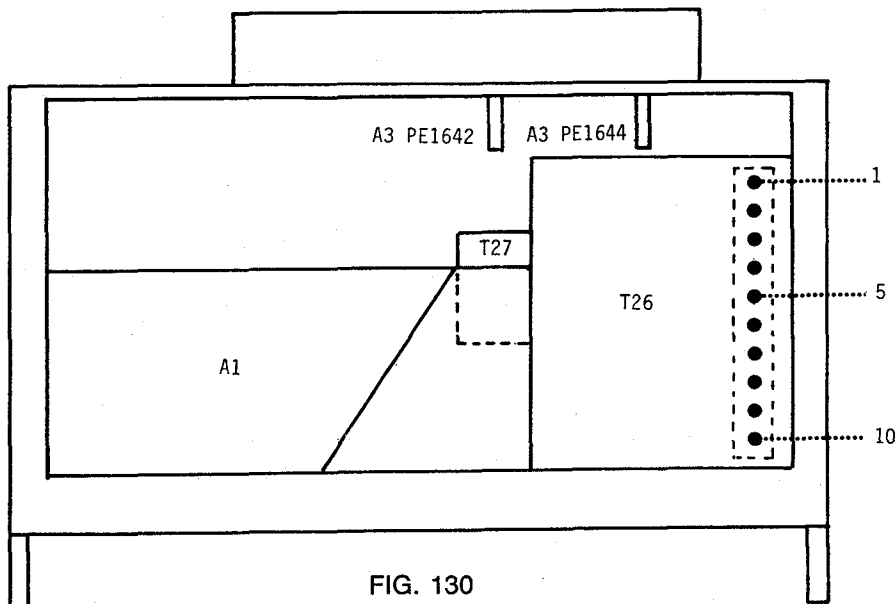
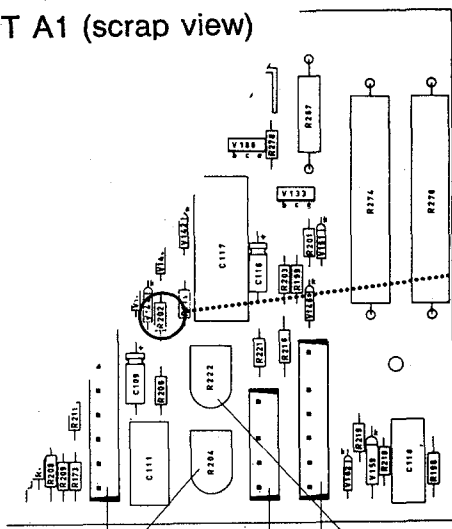

FIG. 130

PRINT UNIT A1 (scrap view)



Note : the location of R202 is identical for PE1642-44-46-48

FIG. 310

PE 1642 UNIT A3 (scrap view)

PE1642 UNIT A3 (scrap view)

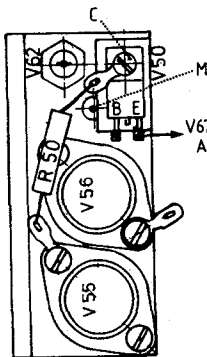

FIG. 330

PE 1644 UNIT A3 (scrap view)

M hole for BTW40-400R (insulated)

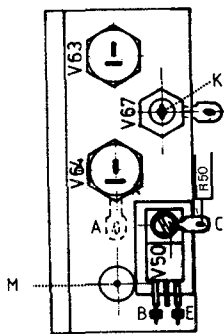
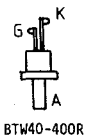

FIG. 331

T27 AUXILIARY TRANSFORMER

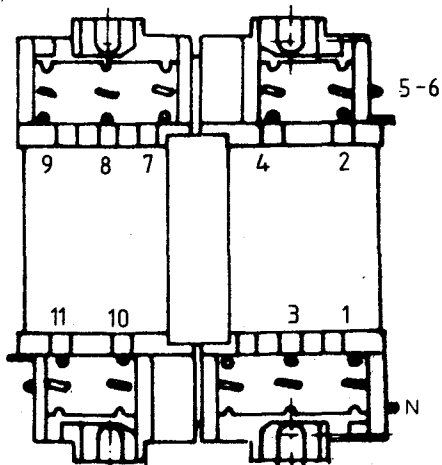

FIG. 560

PE 1642-44-46-48/00: EXTERNAL CONNECTIONS

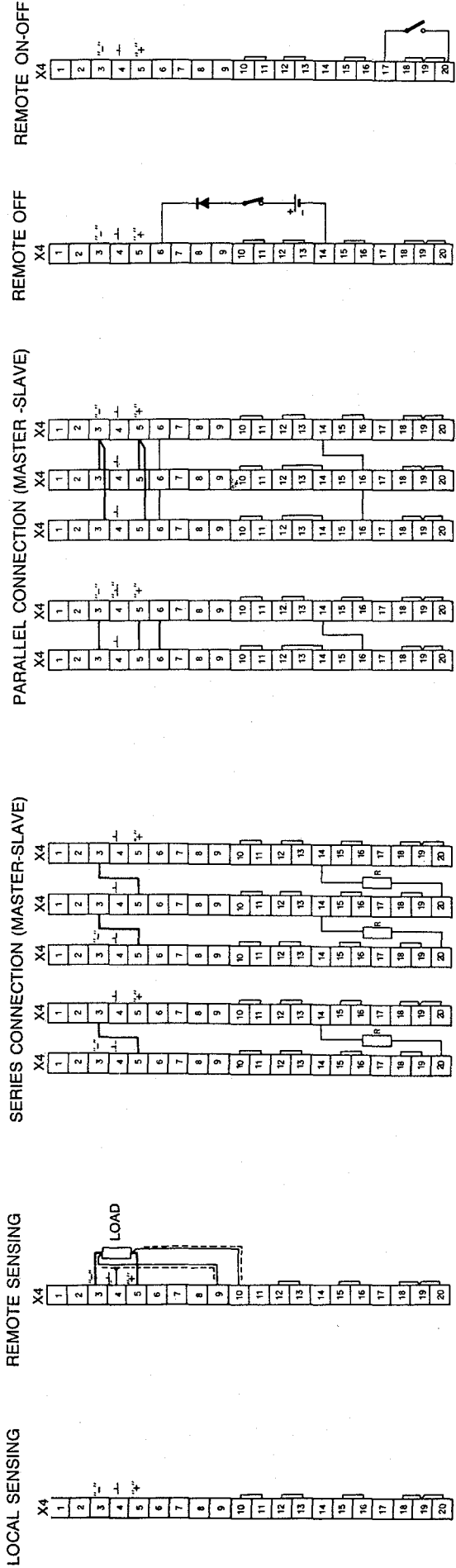

FIG. 224 W/606

FIG. 230 W/607

FIG. 241 W/609

FIG. 246 W/608

FIG. 260 W/610

FIG. 261 W/611

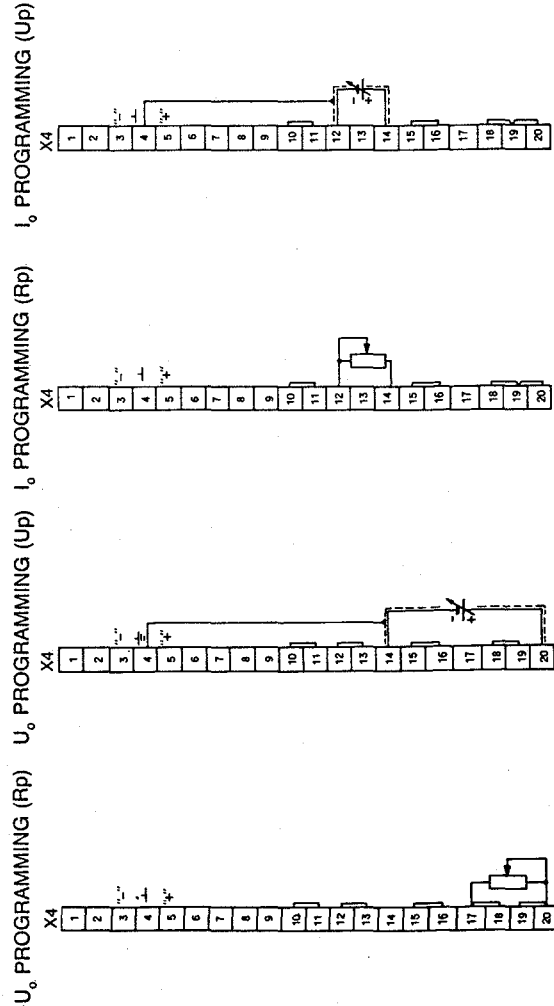

FIG. 274 W/612

FIG. 279 W/613

FIG. 284 W/614

FIG. 289 W/615

FIG. 294 W/616

FIG. 295 W/617

Connection for combination of facilities
* crowbar protection only for PE 1642 — PE 1644

PE 1367/00 BLOCK DIAGRAM

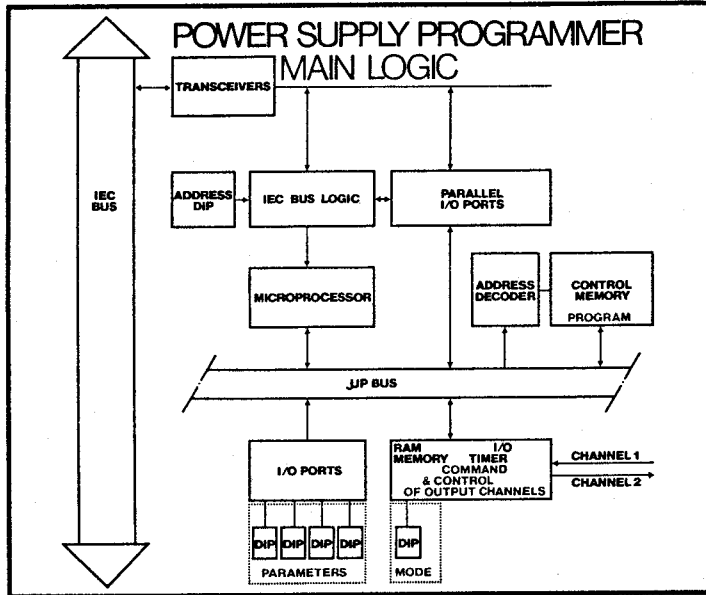

FIG. 800

PE 1367/00 BLOCK DIAGRAM: CHANNEL 1

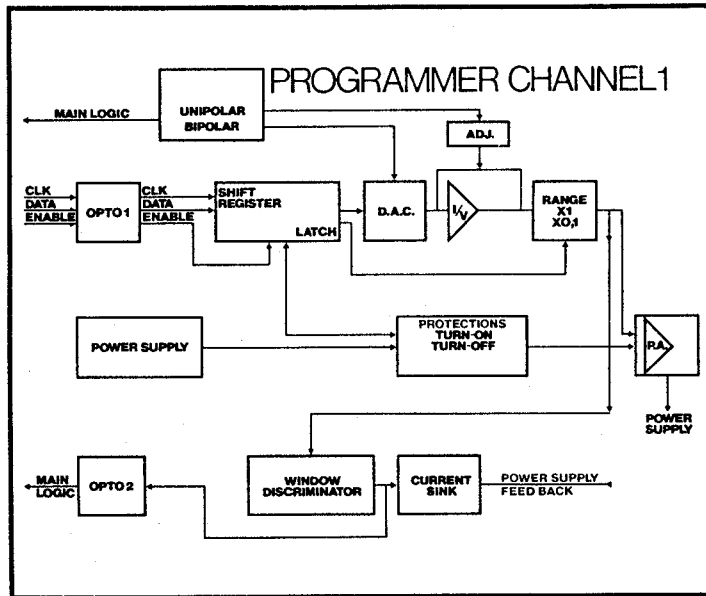

FIG. 801

CONNECTIONS

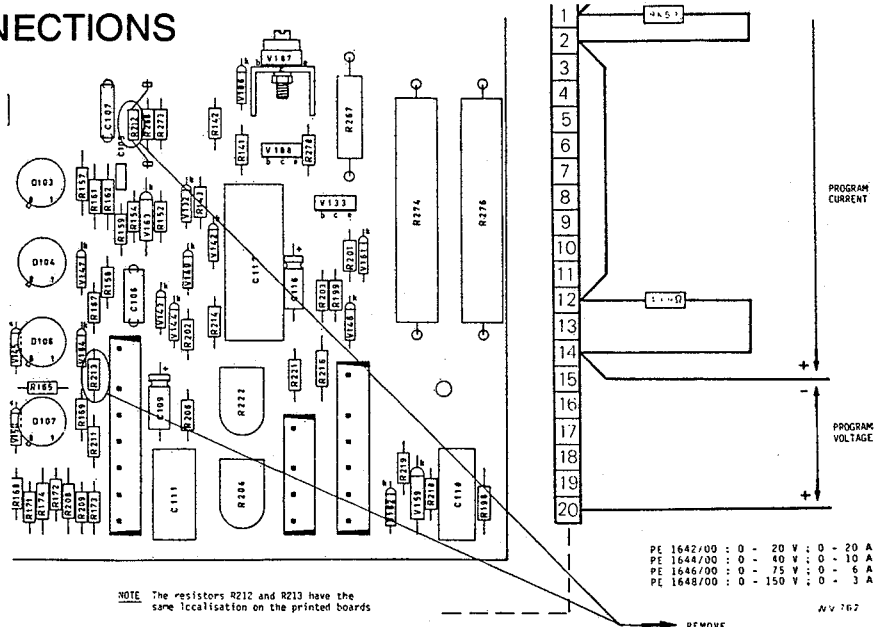
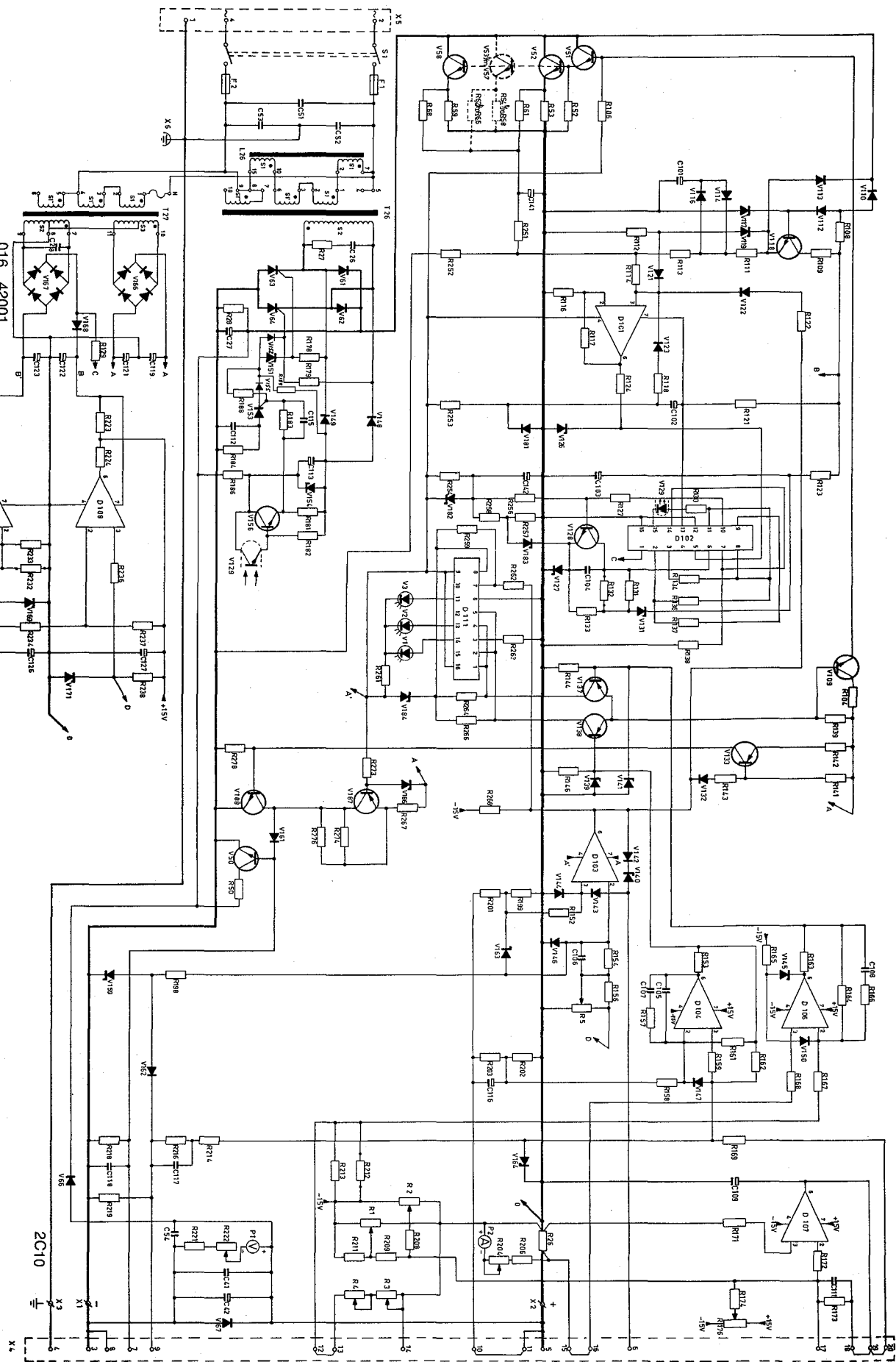

FIG. 802

PE 1642/00 : CIRCUIT DIAGRAM



SUBJECT TO ALTERATIONS WITHOUT NOTICE
 ANDERUNGEN VORBEHALTEN
 NOUS NOUS RESERVONS LE DROIT DE MODIFIER SANS PREAVIS

FIG. 1000

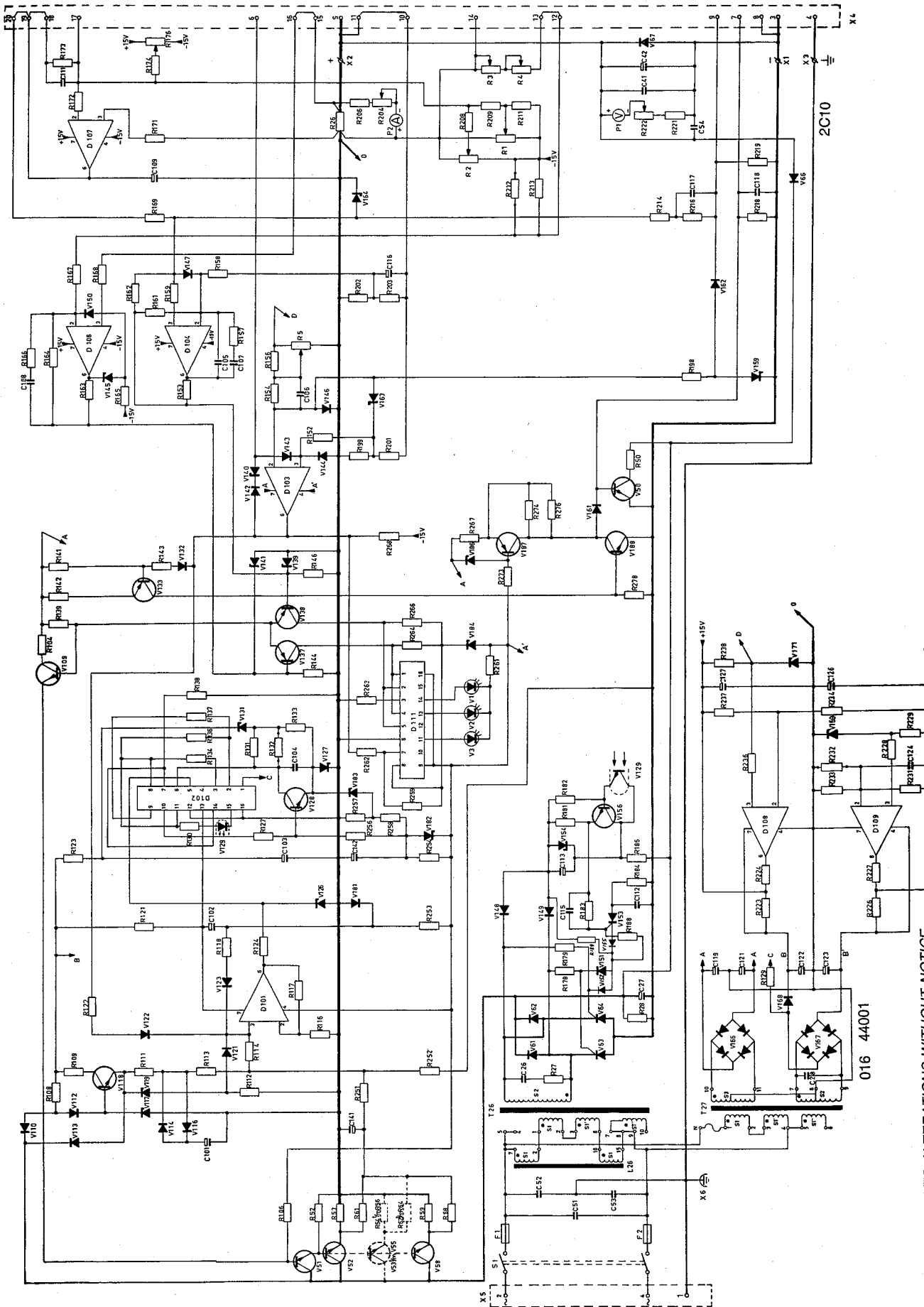
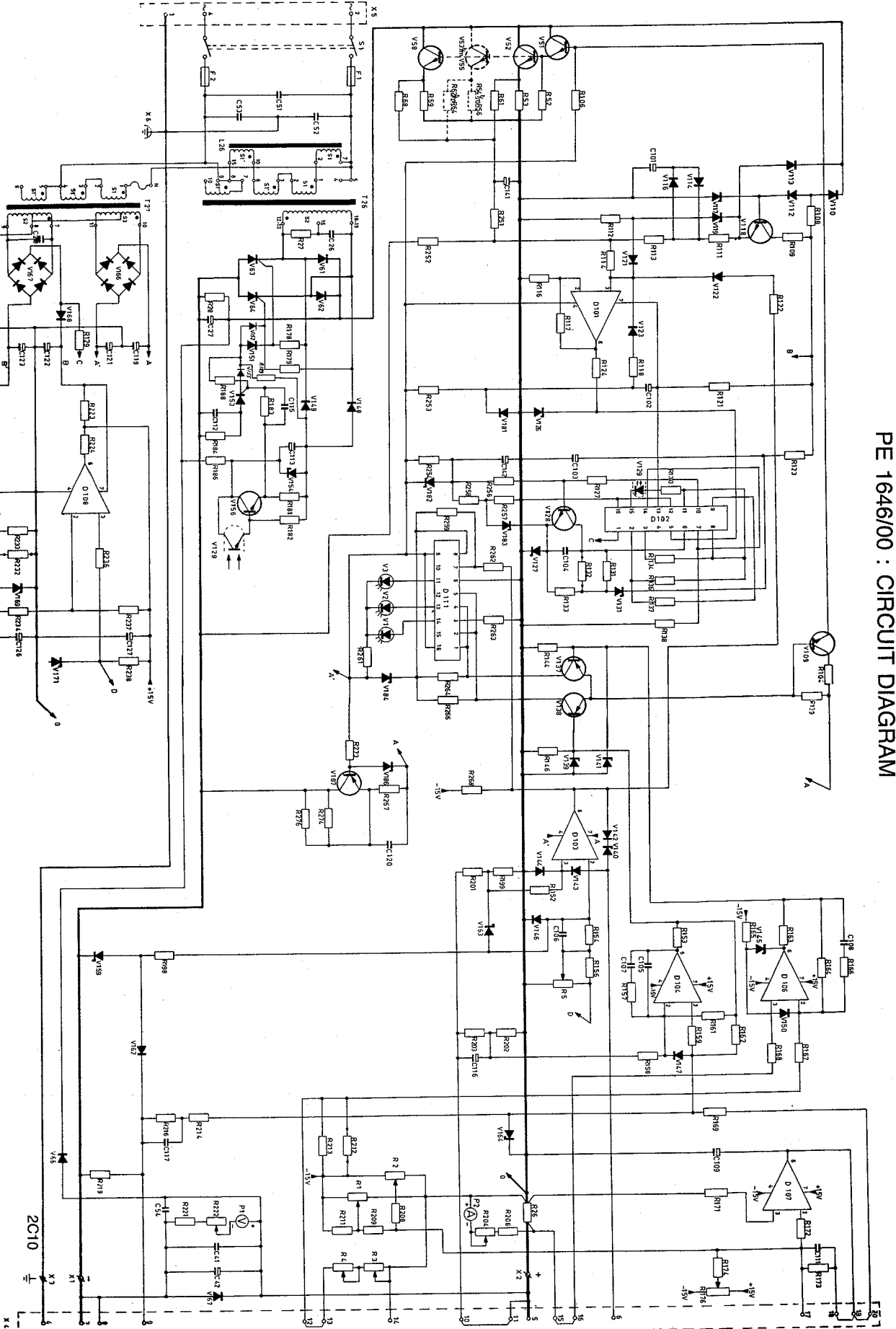

FIG. 1001
 SUBJECT TO ALTERATIONS WITHOUT NOTICE
 ÄNDERUNGEN VORBEHALTEN
 NOUS NOUS RESERVONS LE DROIT DE MODIFIER SANS PREAVIS

PE 1646/00 : CIRCUIT DIAGRAM



SUBJECT TO ALTERATIONS WITHOUT NOTICE
 ANDERUNGEN VORBEHALTEN
 NOUS NOUS RESERVONS LE DROIT DE MODIFIER SANS PREAVIS

FIG. 1002

PE 1648/00 : CIRCUIT DIAGRAM

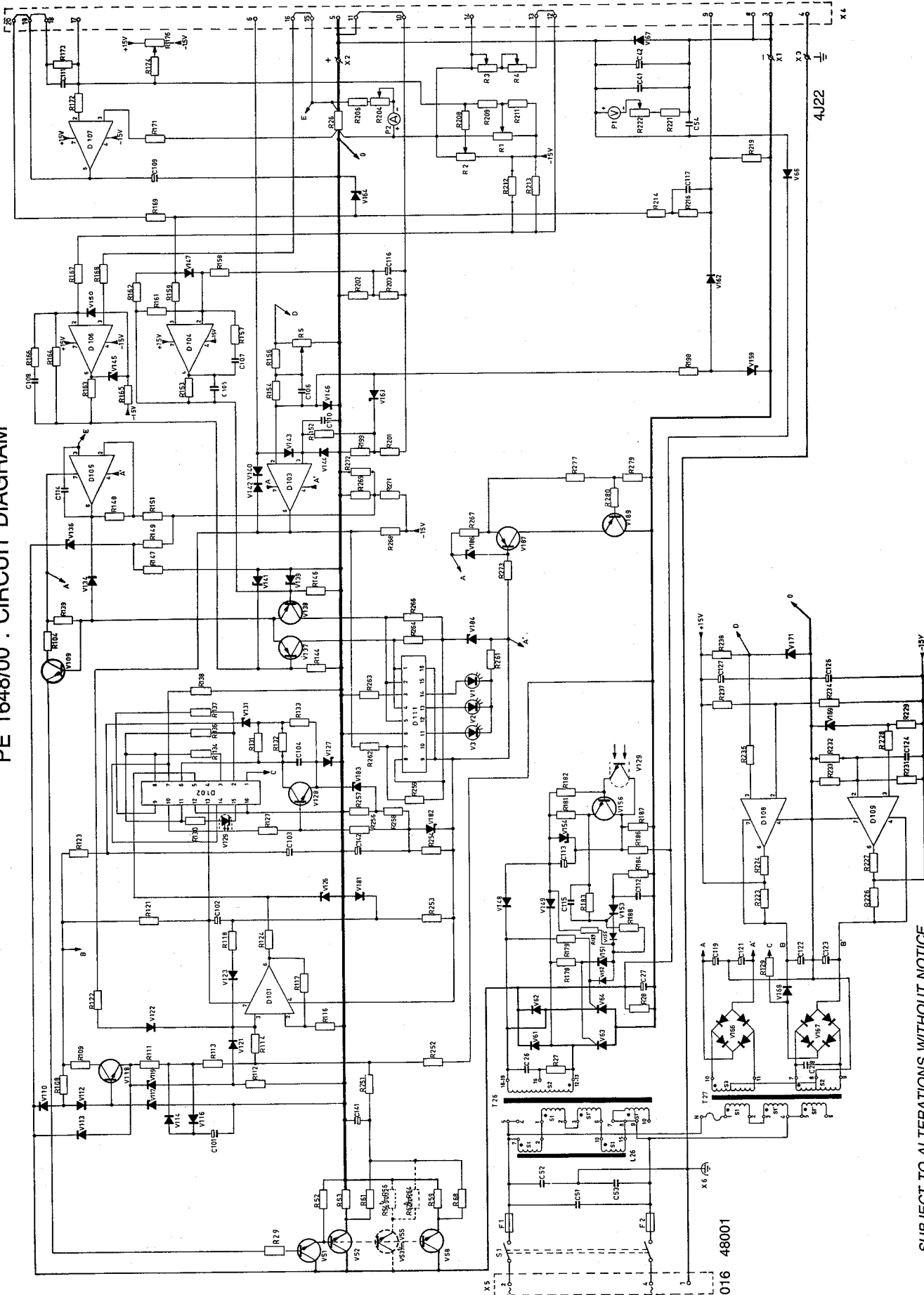

FIG. 1003

SUBJECT TO ALTERATIONS WITHOUT NOTICE
 ÄNDERUNGEN VORBEHALTEN
 NOUS RESERVONS LE DROIT DE MODIFIER SANS PREAVIS

Sales and service all over the world

Alger: Bureau de Liaison Philips,
24 bis, Rue Bougainville,
El Mouradia, Alger, tel: 213-565672

Argentina: Philips Argentina S.A.,
Cassila de Correo 3479, (Central), 1430 Buenos Aires,
tel: 54-1-5422411/5422512/5422613

Australia: Philips Scientific & Industrial,
25-27 Paul Street, P.O. Box 119,
North Ryde/NSW 2113, tel: 61-2-8888222
Service Centre
FCS Service
2 Greenhills Avenue,
Moorebank, P.O. Box 269,
Liverpool / NSW 2170,
Tel: 61-2-6072000

Bangladesh: Philips Bangla Desh Ltd.,
16-17 Kawan Bazar,
P.O. Box 62, Ramna, Dacca, tel: 325081/5, 411576

Belgium/Belgique: Philips & MBE associated S.A.,
Scientific and Industrial Equipment Division,
80 Rue des Deux Gares, 1070 Bruxelles,
tel: 32-2-5256111

Bolivia: E.P.T.A.
I&E Service,
Cañon Postal 20942, La Paz

Brazil: Philips do Brasil Ltda.,
Av. Eng. Luiz Carlos Berrini, 3009, Caixa Postal 1900,
CEP 04571 Sao Paulo (S.P.),
tel: 55-11-2411611
Service Centre
Sistemas Profissionais,
Rua Anton Philips 1,
Caixa Postal 7018,
07000 Guarulhos - S.P.,
tel: 55-11-2090111

Canada: Philips Electronics Ltd.,
Test and Measurement Dept.,
1001 Ellesmere Road,
Scarborough (Ontario) M1P-2W7
tel: 1-416-2928200

Chile: Philips Chilena S.A.,
Division Profesional, Avda. Santa Maria 0760,
Casilla Postal 2687, Santrago de Chile, tel: 770038

Colombia: Industrias Philips de Colombia S.A.,
Calle 13 no 51-39, Apartado Aereo 4282,
Bogota, tel: 2600600

Danmark: Philips A/S,
Strandlodsvej 4,
P.O. Box 1919, 2300 København S,
tel: 45-1-572222

Deutschland (Bundesrepublik): Philips GmbH,
Unternehmensbereich Elektronik für
Wissenschaft und Industrie, Miramstrasse 87,
Postfach 310 320, 3500 Kassel Bettenhausen,
tel: 49-561 5010

Ecuador: Philips Ecuador C.A.,
Casilla 343, Quito, tel: 593-2-239080

Egypt: Philips Egypt Branch of Philips Midden Oosten N.V.
10, Abdel Rahman el Rafei Street, P.O. Box 1687, Cairo,
tel: 20-2-490922/490926/490928/492237

Eire: Philips Electrical (Ireland) Ltd.,
Newstead, Clonskeagh, Dublin 14, tel: 353-1-693355

España: Philips Ibérica S.A.E.,
Dpto. Aparatos de Medida, Martínez Villergas 2,
Apartado 2065, Madrid 28027,
tel: 34-1-4042200/4043200/4044200
Service Centre,
Dpto. Tco. de Instrumentación,
Calle de Albasan 75, Madrid 28017,
tel: 34-1-2045940/2047025/2047105

Ethiopia: Philips Ethiopia (Priv. Ltd. Co.),
Ras Abebe Aregay Avenue,
P.O.B. 2565,
Addis Ababa, tel: 448300

Finland: See Suomi

France: S.A. Philips Industrielle et Commerciale,
Division Science et Industrie,
105 Rue de Paris, B.P. 62, 93 002 Bobigny Cedex
tel: 33-1-8301111

Greece: See Hellas

Hellas: Philips S.A. Hellénique,
54 Avenue Syngrou, P.O. Box 3153,
Athens 10210, tel: 30-1-9215311

Hong Kong: Philips Hong Kong Ltd.,
29/F Hopewell Centre,
17, Kennedy Road, G.P.O. Box 2108,
Hong Kong,
tel: 852-2-283298

India: Peico Electronics & Electricals Ltd.,
I&E Equipment, Shivsagar Estate,
Block "A", Dr. Annie Besant Road,
P.O. B. 6598, Warli, Bombay 400 018 (WB),
tel: 91-22-4921500/4921513

Indonesia: P.T. Daeng Brothers,
P.O. Box 41 Tebet, Jakarta

Iran: Philips Iran Ltd., P.O.B. 11365-3891, Teheran;
tel: 98-21-674138/675158

Iraq: Philips Midden Oosten B.V., Baghdad Branch,
Munir Abbas Building,
4th floor, South Gate, P.O. box 5749, Baghdad;
tel: 880409

Island: Heimilsteikei SF, Saetun 8, Reykjavik;
tel: 24000

Italia: Philips S.p.A., Sezione I&E/T&M,
Viale Elvezia 2, 20052 Monza (MI); tel: 39-39-36351

Japan: See Nippon

Kenya: Philips (Kenya) Ltd.,
01 Kalou Road, Industrial Area,
P.O. B. 30554, Nairobi, tel: 254-2-557999

Lebanon: Philips Middle East S.A.R.L.,
P.O. Box 11 670, Beyrouth, tel: 382300

Malaysia: Philips Malaysia Snd Bhd.,
Professional Division,
Resource Plaza, No 4, Pesiaran Barat
P.O. Box 12163, Petaling Jaya, Selangor
Kuala Lumpur, tel: 60-3-554411
Service Centre
76, Jalan Universiti
Petaling Jaya
Tel: 60-3-562144

México: Telecomunicaciones y
Sistemas Profesionales S.A. de C.V.,
Poniente 152, Nbr 659
Col industrial Vallejo
02300 Mexico D.F.,
Tel: 52-5-5874477

Morocco: Philips Maroc S.A., 304 Boulevard Mohammed V,
B.P. 10896, Bandoeng, Casablanca 05;
tel: 212-302992/303446/304764

Nederland: Philips Nederland,
Hoofdgroep PPS, Boschdijk 525, Gebouw VB,
5600 PD Eindhoven, tel: 31-40-793333

Ned. Antillen: Philips Antillana N.V.,
Schottgatweg Oost 146,
Postbus 3523, Willemstad, Curacao,
tel: 599-9-615277/612799

New Zealand: Philips New Zealand Ltd.,
Scientific and Industrial Equipment Division,
68-86 Jervois Quay, G.P.O. Box 2097,
Wellington; tel: 64-4-735735

Nigeria: Associated Electronic Products (Nigeria) Ltd.,
KM16, Ikorodu Road, Ojota, P.O. B. 1921, Lagos,
tel: 234-1-900160/69

Nippon: NF Trading Co. Ltd.,
Kimimoto Bldg 11 2,
Tsunashima Higashi 1-Chome, Kohoku ku,
Yokohama

Norge: Norsk A.S. Philips,
Dept. Industry and Telecommunication, Sandstuveien 70,
Postboks 1, Manglerud, N 0680 Oslo 6, tel: 47-2-680200

Osterreich: Osterreichische Philips Industrie GmbH,
Abteilung Industrie Elektronik,
Triesterstrasse 64,
Postfach 217, A-1100 Wien,
tel: 43-222-645521/629141

Pakistan: Philips Electrical Co. of Pakistan Ltd.,
P.O. B. 7101,
Karachi 3; tel: 92-21-725772

Paraguay: Philips del Paraguay S.A.,
Av. Artigas 1519,
Casilla de Correo 605, Asunción;
tel: 595-21-291924/291934

Perú: Philips Peruana S.A.,
Av. Alfonso Ugarte 1268, Lima 5,
Apartado Aereo 1841, Lima 100, tel: 51-14-326070

Philippines: Philips Industrial Development Inc.,
2246 Pasong Tamo,
Makati, Metro Manila, tel: 63-2-868951/868959

Portugal: Philips Portuguesa S.A.R.L.,
1009 Lisboa Codex, Av. Eng. Duarte Pacheco 6, 1000 Lisboa;
tel: 351-1-683121/9
Service Centre:
Servicos Técnicos Profissionais, Outeira/Carnaxide, P.O. Box 55
2795 Linda-a-Velha; tel: 351-1-2180071

Saudi Arabia: Delegate Office of Philips Industries,
Sabreen Bldg., Airport Road, P.O. Box 9844,
Riyadh; tel: 966-1-4777808/4778463/4778216/4778335

Schweiz-Suisse-Svizzera: Philips A.G.,
Allmendstrasse 140, Postfach 670, CH-8027 Zurich;
tel: 41-1-4882211

Singapore: Philips Project Development(S) Pte. Ltd.,
Lorong 1, Tao Payoh, 1st floor,
P.O. Box 340, Toa Payoh Central Post Office,
Singapore 9131, tel: 65-2538811

South Africa: South African Philips (Pty) Ltd.,
2 Herb Street, New Doornfontein, P.O.B. 7703,
Johannesburg 2000; tel: 27-11-6179111

South Korea: Philips Electronics (Korea) Ltd.,
260-199, Itaewon-dong, Yongsanku,
C.P.O. Box 3680, Seoul; tel: 794 5011/5

Suomi: Oy Philips AB.,
Kaivokatu 8,
P.O. Box 255,
SF-00101 Helsinki 10; tel: 358-0-17271
Service Centre
Sinikalliontie 1-3,
P.O. Box 11, SF-02630 Espoo;
tel: 358-0-523122

Sverige: Philips Försäljning AB,
Div. Industrielektronik, Tegelvadsvägen 1,
Fack, S-11584 Stockholm; tel: 46-8-7821000

Syria: Philips Moyen Orient S.A.R.L., Rue Fardoss 79,
B.P. 2442, Damas;
tel: 221650/218605/228003/221025

Taiwan: Philips Taiwan Ltd.,
150, Tun Hya North Road,
P.O. Box 22978, Taipei;
tel: 886-2-712 0500

Tanzania: Philips (Tanzania) Ltd.,
T.D.F.L. Building (1st floor), Ohio/Upanga Road
P.O. Box. 20104, Dar es Salaam; tel: 29571/4

Thailand: Philips Electrical Co. of Thailand Ltd.,
283 Silom Road, P.O. Box 961, Bangkok 10500;
tel: 66-2-2336330/9/2355665.8

Tunisia: S.T.I.E.T., 32 bis, Rue Ben Ghedhahem,
Tunis; tel: 216-1-348666

Türkiye: Türk Philips Ticaret A.S.,
Inonu Caddesi 7B/80
Posta Kutusu 504, Beyoglu,
Istanbul, tel: 90-1-1435910

United Arab Emirates: Philips Middle East B.V.,
Dubai International Trade Centre, Level 11,
P.O. Box 9269, Dubai; tel: 971-4-37700

United Kingdom: Pye Unicam Ltd., York Street,
Cambridge CB1 2PX; tel: 44-223-358866
Service Centre:
Pye Unicam Ltd.,
Service Division,
Beddington Lane,
Croydon CR9 4EN;
Tel.: 44-1-6843670

Uruguay: Industrias Philips del Uruguay S.A.,
Avda Uruguay 1287, Casilla de Correo 294,
Montevideo, tel: 915641/2/3/4-919009
Service 387777-387878-388484

U.S.A.:
Philips Test and Measurement Department Inc.,
California, Garden Grove 92645
12882 Valley View Street, Suite 9,
tel: (213) 594-8741/(714) 898-5000
California, Milpitas 95035
477 Valley Way;
tel: (408) 946-6722
Florida, Winter Park 32789
1850 Lee Road, Suite 229,
tel: (305) 628-1717
Illinois, Itasca 60143
500 Park Blvd., Suite 1170,
tel: (312) 773-0616
Massachusetts, Woburn 01801
21 Olympia Avenue;
tel: (617) 935-3972
Minnesota, Minneapolis 55420
7851 Metro Parkway, Suite 302,
tel: (612) 854-2426
New Jersey, Mahwah 07430
85 McKee Drive;
tel: 1-201-529-3800, Toll-free 800-631-7172

Venezuela: Industrias Venezolanas Philips S.A.,
Av. Diego Cisneros, Edificio Centro Colgate,
Apartado Aereo 1167, Caracas 1010-A;
tel: 58-2-2393811/239222/2393933

Zaire: S.A.M.E./s.a.r.l., 137, Boulevard du 30 juin,
B.P. 16636, Kinshasa;
tel: 31887-31888-31921

Zambia: Philips Electrical Zambia Ltd.,
Mweneshi Road, P.O. B. 31878, Lusaka;
tel: 218511/218701

Zimbabwe: Philips Electrical (Pvt) Ltd.,
62 Mutare Road, P.O. Box 994, Harare,
tel: 47211/48031

For technical documentation:
PHILIPS Concern Service
Technical Service Publications
Building 5896
5600 MD EINDHOVEN, THE NETHERLANDS
Tel. 31-40-735556 — Telex 35000 PHTC-NL

For information on change of address:
Philips Export B.V.,
Scientific and Industrial Equipment Division,
Test and Measurement, Building TQ 111-4, P.O. Box 218,
5600 MD Eindhoven - The Netherlands
Tel. 31-40-784506

For countries not listed here:
Philips Export B.V., I&E Export,
Test and Measurement, Building HBS, P.O. Box 218,
5600 MD Eindhoven - The Netherlands;
Tel. 31-40-755546

T&M/B61001