

General Purpose Chassis for PXI and CompactPCI

General-Purpose Chassis

PXI-1000B, PXI-1002, PXI-1006

- Accepts both 3U PXI and 3U CompactPCI modules
- Filtered, forced-air cooling
- Integrated, internal power supplies
- Complies with PXI and CompactPCI specifications
- Complies with IEEE 1101.10 mechanical packaging

PXI-1000B

- General-purpose, 8-slot chassis
- Multiple power supply options:
 - 300 W removable power supply with universal AC input or
 - 150 W removable power supply with AC and DC inputs
- Optional battery backup (with AC/DC option only)
- Remote power inhibit and monitoring

PXI-1002

- Low-cost, compact 4-slot chassis
- 170 W power supply with universal AC input
- Optional side handle and feet kit for portability

PXI-1006

- High-performance, 18-slot chassis
- Two PXI-to-PXI bridges
- 600 W removable power supply with universal AC input
- Remote power inhibit and monitoring

NEW



Chassis

Overview

National Instruments general-purpose PXI chassis, PXI-1000B, PXI-1002, and PXI-1006 – provide you with platform options to meet your measurement and automation application needs. These chassis incorporate all features defined by the PXI and CompactPCI specifications, including a rugged, modular construction, integrated cooling, and high-performance backplane with integrated timing and triggering features. The PXI-1000B 8-slot chassis, with a high-output power supply and compact structural design, is a versatile, flexible platform. The PXI-1002 4-slot chassis is the ideal platform for low-cost, compact PXI systems. The new PXI-1006 is the ideal platform for high-module-count, high-performance applications.

Backplane

National Instruments general-purpose PXI chassis backplanes support all the high-precision synchronization and triggering signals defined in the PXI specification, including the internal 10 MHz reference clock, trigger bus, star trigger bus, and module-to-module local buses. Use the 10 MHz reference clock to achieve tight synchronization of your system modules (up to 17 modules with the PXI-1006). Through the use of line-equalization techniques, the star trigger bus enables a PXI star trigger controller to deliver trigger signals to multiple modules with less than 1 ns of skew.

The PXI-1006 backplane extends the PCI bus and PXI timing triggering signals to 18-slots with two PXI-to-PXI bridges that transparently extend the PCI bus. The PXI-1006 backplane also supports the star trigger bus to the maximum 13 peripheral slots. If greater synchronization is required than is provided by the internal reference clock, the PXI-1000B or PXI-1006 automatically senses

and sources an alternate clock source when a source module is installed in slot 2. (See PXI-6608 on page 127)

Power Supply

National Instruments general-purpose PXI chassis contain rugged, integrated, independently cooled, universal AC power supplies. The PXI-1000B and PXI-1006 use removable power supplies. In addition, both of these power supplies integrate with the fans in a single, rugged, modular unit that can be removed quickly and easily for service, resulting in a MTTR (mean-time to repair) of less than five minutes. An optional power supply for the PXI-1000B accepts either AC or DC inputs (see Figure 1). An optional internal battery pack can also supply the PXI-1000B with temporary power to function as an uninterruptible power supply.

Remote Power Inhibit and Monitoring

The PXI-1000B and PXI-1006 incorporate remote power and inhibit monitoring through a DB-9 connector on the back of the chassis (see Figure 1). Use this connector to switch power off remotely or monitor the power in your chassis.

Cooling

Fans provide integrated and filtered forced-air cooling for all of the NI general-purpose chassis. This cooling capability is separate and independent of power supply cooling. To accommodate the wide

INFO CODES

For more information, or to order products online visit ni.com/info and enter:

pxi1000B
pxi1002
pxi1006

BUY ONLINE!

General-Purpose Chassis for PXI and CompactPCI

variety of applications and application environments for the PXI-1000B and PXI-1006 chassis, two user-selectable fan speed settings are available – a setting for quiet operation and a maximum fan speed setting for maximum cooling capability (see Figure 1).

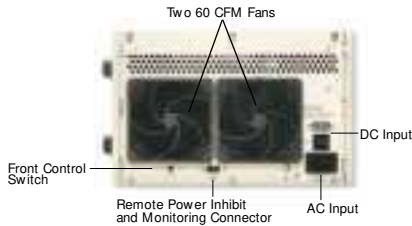

Figure 1. Rear view of PXI-1000B with Combination AC/DC Supply

Using sophisticated and rigorous computer modeling techniques (see Figure 2), NI designed the general-purpose chassis with airflow venting to ensure that all slots receive more uniform airflow. Uniform airflow across your PXI modules reduces operating temperature, prolongs life, and increases mean-time between failure (MTBF).

Installation

National Instruments general-purpose PXI chassis have flexible designs for easy installation in a variety of applications. Use the optional rack-mount kit for your particular model to mount your chassis in a 19 in.



Figure 2. Computer modeling of the airflow aided the design of airflow deflectors and venting in the PXI-1006. This is a view of the card-cage from the right side of the PXI-1006.

rack (See Figure 3). You can install the rack mount kit on the front or rear of the chassis; you can also use it to recess the chassis in your instrument cabinet.

For the PXI-1000B and PXI-1006, NI recommends the use of a rack-mount kit for both the front and rear of the chassis. All chassis come with rubber feet for bench-top use and handles for added portability (optional for the PXI-1002).

For custom or embedded applications, use the mounting points located on either side of your model chassis (see Figures 4, 5, and 6). All of these configurations can be assembled or disassembled without ever accessing the interior of the chassis.

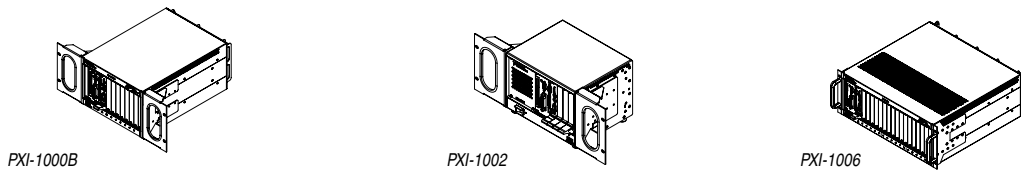

Figure 3. National Instruments General-Purpose Chassis with Rack-Mount Kits

Ordering Information

Step 1. Select your chassis.

PXI-1000B with:

- Universal AC input power supply (300 W)777551-01
- Combination AC and DC input power supply (150 W) ..777551-11
- PXI-1002778114-01
- PXI-1006778303-01

Step 2. Select one or more power cords.

- U.S. 120 VAC763000-01
- Japan 100 VAC763000-01
- United Kingdom 240 VAC763064-01
- Swiss 220 VAC763065-01
- Australian 240 VAC763066-01
- Universal Euro 240 VAC763067-01
- North American 240 VAC763068-01
- DC Power Cord (PXI-1000B AC/DC option only)763418-01

Step 3. Select additional accessories.

PXI-1000B

- Rack-mount kit (for 19 in. rack)777552-01
- 1.7 Ah NiCd battery pack (AC/DC option only)745656-01

PXI-1002

- Rack-mount kit (for 19 in. rack)778152-01
- Side handle and feet kit for portability.....778151-01

PXI-1006

- Rack-mount kit (for 19 in. rack)778302-01

Step 4. Select system set up and installation services.

NI Factory Installation Service (see page 249)

- Customer-Defined Configuration960596-01
- Standard Factory-Defined Configuration960596-02

General-Purpose Chassis for PXI and CompactPCI

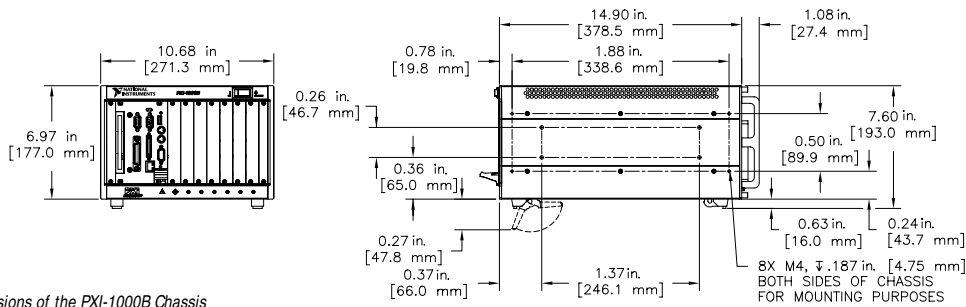

Figure 4. Dimensions of the PXI-1000B Chassis

Specifications* – PXI-1000B

Complies with PXI specification
Accepts modules compliant with CompactPCI, PICMG 2.0 specification

Electrical

AC Power Supply

Input voltage 90 to 264 VAC universal
Input frequency 47 to 63 Hz
Output

Maximum usable power 300 W
Available Current

VDC	ADC (steady state)
+3.3	35
+5	25
+12	4.0
-12	1.0

Combination DC and AC Power Supply

Input (either or both)

DC 10 to 32 VDC
AC
Voltage 85 to 265 VAC
Frequency 45 to 65 Hz

Output

Maximum usable power 150 W
Available Current

VDC	ADC (steady state)
+3.3	10
+5	20 [†]
+12	4.0
-12	0.4

[†] Derated in proportion to the power drawn at +3.3 V

Cooling

Fans 2 @ 60 cfm, with filters
Total Capacity 300 W

Physical

Number of PXI slots 8 (1 controller, 7 peripheral)
Number of controller expansion slots 3 (left of controller)
Dimensions 40.4 by 27.0 by 17.7 cm
[15.9 by 10.6 by 7 in.]
Height for rack-mount installation 4U
Weight
AC power supply 8.6 kg [19 lb]
Combination DC and AC power supply 8.0 kg (17.6 lb)
Combination DC and AC power supply
with battery pack 9.1 kg (20.1 lb)

Operating Environment

Ambient temperature range 0 to 55 °C (Meets IEC-60068-2-1 and IEC 60068-2-2.)
Relative humidity range 10 to 90%, noncondensing (Meets IEC 60068-2-56.)

Storage Environment

Ambient temperature range -20 to 70 °C (Meets IEC-60068-2-1 and IEC 60068-2-2.)
Relative humidity range 5 to 95%, noncondensing (Meets IEC 60068-2-56.)

Mean Time Between Failures (MTBF)

AC 115,000 hours
AC/DC 79,000 hours
(Predictions performed in accordance with Belcore methods)

Backplane

Backplane bare-board material UL 94V-0 rated
Backplane connector Conforms to IEC-917 and IEC 1076-4-101, UL 94V-0 rated

Shock and Vibration

Functional shock 30 g peak, half-sine, 11 ms pulse (Meets IEC 60068-2-27 Test profile developed in accordance with MIL-T-28800E.)
Random vibration
Operating 5 to 500 Hz, 0.3 g_{rms}
Nonoperating 5 to 500 Hz, 2.4 g_{rms} (Meets IEC 60068-2-64 Nonoperating test profile developed in accordance with MIL-T-28800E and MIL-STD-810E Method 514.)

Safety and EM C/EMI Compliance

Safety EN 61010-1:1993
EM C/EMI CE, C-Tick, and FCC Part 15
Electrical Emissions EN 55011 Class A at 10 m, and FCC Part 15 Class A above 1 GHz
Electrical Immunity EN 61326:1998, Table 1

*Specifications subject to change without notice.

General-Purpose Chassis for PXI and CompactPCI

General-Purpose Chassis

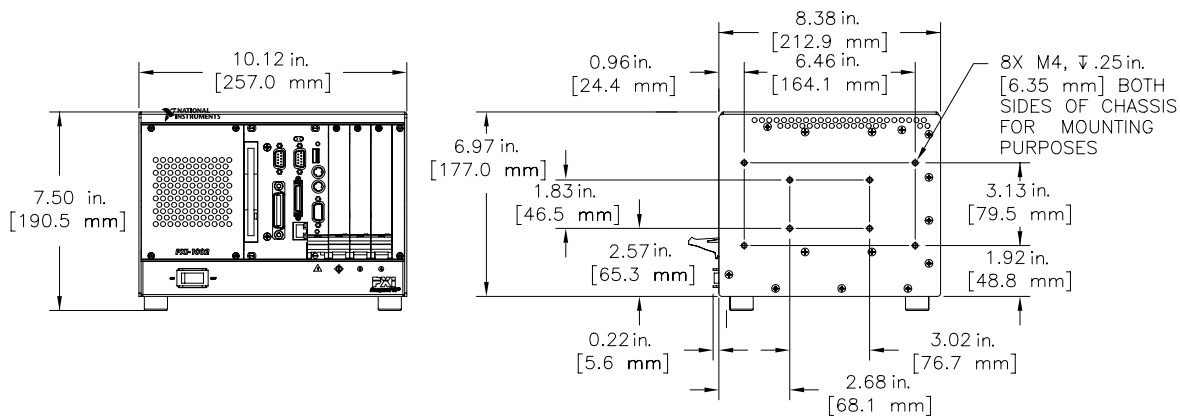

Figure 5. Dimensions of the PXI-1002 Chassis

Specifications* – PXI-1002

Complies with PXI specification
Accepts modules compliant with CompactPCI, PICMG 2.0 specification

Electrical

Input voltage 90 to 135/180 to 265 VAC auto select
Input frequency 47 to 63 Hz
Output
Maximum usable power 170 W
Available current

VDC	ADC (steady state)
+3.3	14 [†]
+5	20 [†]
+12	4.0
-12	0.8

[†]Total combined power from +3.3 V and +5 V is 112 W maximum

Cooling

Fan 1 @ 93 cfm, with filter
Total capacity 170 W

Physical

Number of PXI slots 4 (1 controller, 3 peripheral)
Number of controller expansion slots 3 (left of controller)
Dimensions 21.3 by 25.7 by 19.1 cm
(8.4 by 10.1 by 7.5 in)
Height for rack-mount installation 4U
Weight 4.3 kg [9.5 lb]

Operating Environment

Ambient temperature range 0 to 50 °C (Meets IEC 60068-2-1 and IEC 60068-2-2.)
Relative humidity range 10 to 90%, noncondensing (Meets IEC 60068-2-56.)

Storage Environment

Ambient temperature range -20 to 70 °C (Meets IEC-60068-2-1 and IEC 60068-2-2.)
Relative humidity range 5 to 95%, noncondensing (Meets IEC 60068-2-56.)

Mean Time Between Failures (M TBF)

MTBF 85,000 hours
(Prediction performed in accordance with Belcore methods)

Backplane

Backplane bare-board material UL 94V-0 rated
Backplane connector Conforms to IEC-917 and IEC 1076-4-101, UL 94V-0 rated

Shock and Vibration

Functional shock 30 g peak, half-sine, 6 ms pulse
Sine vibration
Operating 10 to 60 Hz, 0.5 g_{rms}
Nonoperating 10 to 60 Hz, 1.0 g_{rms}

Safety and EM C/EM I Compliance

Safety EN 61010-1:1993
EMC/EMI CE, C-Tick, and FCC Part 15
Electrical Emissions EN 55011 Class A at 10 m, and FCC Part 15 Class A above 1 GHz
Electrical Immunity EN 61326:1998, Table 1

*Specifications subject to change without notice.

Chassis

General-Purpose Chassis for PXI and CompactPCI

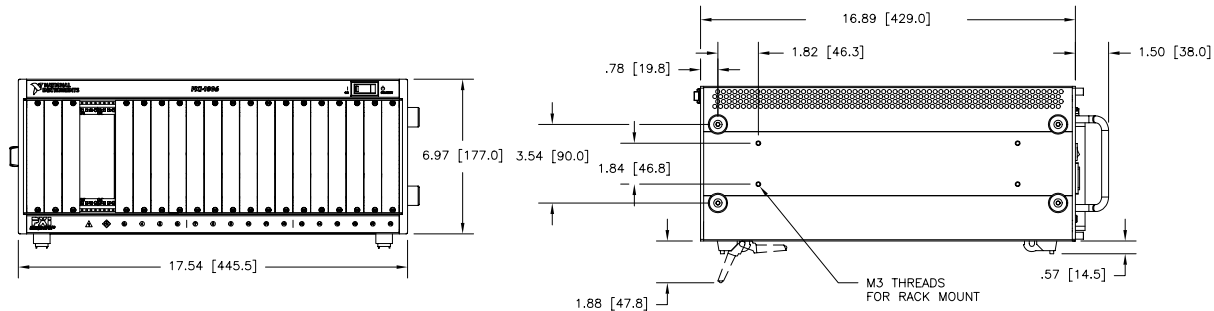

Figure 6. Dimensions of the PXI-1006 Chassis

Specifications* – PXI-1006

Complies with PXI Specification
Accepts modules compliant with CompactPCI, PICMG 2.0 specification

Electrical

Input voltage 90 to 264 VAC universal
Input frequency 47 to 63 Hz

Output

Maximum usable power 600 W
Available current

VDC	ADC (steady state)
+3.3	60 A
+5	60 A
+12	9.0 A
-12	1.8 A

Cooling

Fans 3 @ 130 cfm high or temperature controlled quiet settings
Air Filters Rear accessible, washable
Total Capacity 600 W modules only (power supply cooled independently)

Physical

Number of PXI/CompactPCI slots 18 (1 controller, 17 peripheral)
Number of controller expansion slots 3 (left of controller)
Dimensions 44.9 by 47.1 by 17.8 cm (17.5 by 18.4 by 7.0 in.)

Height for rack-mount installation 4U
Weight 13.6 kg (29.9 lb)

Operating Environment

Ambient temperature range 0 to 55 °C (Meets IEC 60068-2-1 and IEC 60068-2-2)
Relative humidity range 10 to 90%, noncondensing (Meets IEC 60068-2-56)

Storage Environment

Storage Temperature -40 to 70 °C (Meets IEC 60068-2-1 & IEC 60068-2-2)
Relative humidity range 5 to 95%, noncondensing (Meets IEC 60068-2-56)

Backplane

PXI peripheral slots on star trigger bus 3 through 15
PXI peripheral slots with access to 10 MHz reference clock All
PXI trigger bus segments 3 (slots 1-6, 7-12, 13-18)
PXI peripheral slots with slot-to-slot local bus All (slot 2 – right only, slot 18 – left only)
Number of PXI-to-PXI bridges 2
PXI-to-PXI bridge locations Between slots 6 and 7, Between slots 12 and 13
Backplane bare-board material UL 94V-0 rated
Backplane connector Conforms to IEC-917 and IEC 1076-4-101, UL 94V-0 rated

Shock and Vibration

Functional shock 30 g peak, half-sine, 11 ms pulse. (Meets IEC 60068-2-27. Test profile developed in accordance with MIL-T-28800E)
Random vibration
Operating 5 to 500 Hz, 0.31 g_{rm}
Nonoperating 5 to 500 Hz, 2.4 g_{rms} (Meets IEC 60068-2-64 Nonoperating Test profile developed in accordance with MIL-T-28800E and MIL-STD-810E, Method 514)

Safety and EM C/EMI Compliance

Safety EN 61010-1:1993
EMC/EMI CE, C-Tick, and FCC Part 15
Electrical Emissions EN 55011 Class A at 10 m, and FCC Part 15 Class A above 1 GHz
Electrical Immunity EN 61326:1998, Table 1

*Specifications subject to change without notice.