

INSTRUCTION MANUAL

REGULATED POWER SUPPLIES

LPD SUFFIX A
SERIES



LAMBDA ELECTRONICS

MELVILLE, L. I., N. Y.

INSTRUCTION MANUAL
FOR
REGULATED POWER SUPPLIES

LPD SUFFIX A
SERIES

This manual provides instructions intended for the operation of Lambda power supplies, and is not to be reproduced without the written consent of Lambda Electronics. All information contained herein applies to all LPD suffix A models unless otherwise specified.

LAMBDA ELECTRONICS

MELVILLE, L. I., N. Y.

MAIN PLANT TELEPHONE: 516 MYrtle 4-4200

IM LPD400A

SPECIFICATIONS AND FEATURES

Specifications apply for all metered models.

DC OUTPUT--Voltage regulated for line and load

Voltage Range.....TABLE I
VOLTAGE RANGE

MODEL	LPD-421AFM	LPD-422AFM	LPD-423AFM	LPD-424AFM	LPD-425AFM
VOLTAGE RANGE VDC	0-20	0-40	0-60	0-120	0-250

Multi-Current Ranges.....Current range must be chosen to suit the appropriate maximum ambient temperature. Current ratings apply for entire voltage range.

TABLE II
MAX. CURRENT

MODEL	MAX. CURRENT AT AMBIENT OF:			
	30°C	40°C	50°C	60°C
LPD-421AFM	1.7	1.5	1.3	0.9
LPD-422AFM	1.0	.850	0.70	0.55
LPD-423AFM	0.7A	0.6A	0.5A	0.4A
LPD-424AFM	0.38A	0.32A	0.26	0.20
LPD-425AFM	0.13	0.12	0.11	0.10

REGULATED VOLTAGE OUTPUT

Regulation (line)..... 0.01 percent plus 1.0 millivolt for input variations from 105-132 or 132-105 volts AC

Regulation (load)..... 0.01 percent plus 1.0 millivolt for load variations from no load to full load or full load to no load

Remote Programming

- External Resistor Nominal 200 ohms/volt output
- Programming Voltage One-to-one voltage change
- Ripple and Noise 500 microvolts (or 1 mv for LPD-425FM) rms; 1.5 millivolts (or 3 mv for LPD-425FM) peak-to-peak with either positive or negative terminal grounded
- Temperature Coefficient Output change in voltage less than $(0.015\% + 0.5 \text{ mv}) / ^\circ\text{C}$

DC OUTPUT--Current regulated for line and load; automatic crossover with voltage limit

- Multi-Current Ranges..... Current range must be chosen to suit the appropriate maximum ambient temperature. Current ratings apply for entire voltage range. For maximum current range see Table II Minimum current 1% of 30^o ambient rating in Table II or 5 ma., whichever is greater.
- Voltage Range For voltage range see Table I; voltage ratings apply for entire current range.

REGULATED CURRENT OUTPUT; AUTOMATIC CROSSOVER

- Regulation (line) 5 milliamperes for line variations from 105-132 or 132-105 volts AC
- Regulation (load) 5 milliamperes for load voltage changes from 0 to max. or max. to 0 volts DC

AC INPUT--105-132 volts AC at 47-440 Hz. For input power see Table III.

Ratings apply for 57-63 Hz; derate current 10% for 47-53 Hz input; for other input frequencies consult factory.

TABLE III
INPUT POWER, WATTS*

MODEL	INPUT POWER
LPD-421AFM	175 Watts
LPD-422AFM	190 Watts
LPD-423AFM	180 Watts
LPD-424AFM	170 Watts
LPD-425AFM	115 Watts

*With output loaded to full 30^oC rating and input voltage 132 volts AC, 60 Hz

OVERLOAD PROTECTION

Thermal Thermostat, resets automatically when over-temperature condition is eliminated

Electrical

External Adjustable, automatic, electronic current-limiting circuit, settable to 105 percent of rated current; limits output current to preset limit for protection of load and power supply when external overloads and direct shorts occur

Internal Fuse, "SLO-BLO", 3AG; fuse F1 protects the AC input circuit. Overload of the supply does not cause fuse failure

Fuse F2 provides protection against internal circuit failure in conjunction with overvoltage protector option

INPUT AND OUTPUT CONNECTIONS --Heavy duty terminal block on rear of chassis with 5-foot, 3-wire detachable line cord for all models; five-way binding posts provide for additional positive (+), ground, and negative (-) DC output connections, on front panel of all models

OPERATING AMBIENT TEMPERATURE RANGE AND DUTY CYCLE--Continuous duty from 0°C to 60°C ambient with corresponding load current ratings for all modes of operation

STORAGE TEMPERATURE- (non-operating) -55°C to +85°C

METERS-Voltmeter and ammeter on all models.

CONTROLS

DC output controls..... Coarse and fine voltage and current controls (single ten turn controls for models LPD-424AFM and LPD-425AFM) permit adjustment of DC output; located on front panel of all models

Binding Posts (+) (-) (GND).... Five-way binding posts on all models.

Remote Sensing..... Provision is made for remote sensing to eliminate effect of power output lead resistance on DC regulation.

Power..... Panel mounted switch and indicator light for all units

PHYSICAL DATA

Size 5-3/16" H x 8-3/8" W x 10-5/8 D
Weight 13 lbs. net; 16 lbs. shipping wt.

MOUNTING:

Laboratory bench, table top. Bumpers secured to the base of all LPD suffix A units permit proper circulation of air through the unit. Removal of bumpers will restrict free-flow of air through the unit; avoid removing bumpers

Standard 19" Rack All LPD suffix A units can be used with rack adapters: LRA-1 (slide accomodation provided)
LRA-2 (conventional mount) See figure 14

MODEL OPTIONS

Suffix "R" Fungus Proofing
Option. Standard LPD suffix A power supplies can be obtained with fungus proofing treatment with MIL-V-173 varnish for all fungi nutrient components

Suffix "V" Option. Standard LPD suffix A power supplies can be obtained for 205-265 VAC, 50 Hz input or for 187-242 VAC, 50 Hz input. See nameplate for AC input rating. See schematic diagram for rewiring of AC input.

ACCESSORIES

Rack Adapters Rack adapter LRA-1, with or without chassis slides is available as well as rack adapter LRA-2 which is used for simple rack installations where chassis slides are not required

Blank Panels Half-rack and quarter-rack panels can be used with the Lambda rack adapters, see figure 14

Overvoltage Protector Externally mounted, Overvoltage Protectors LHOV-4, LHOV-5 and LHOV-6 are available for use with LPD suffix A power supplies
LPD-421AFM, LPD-422AFM and LPD-423AFM.

THEORY OF OPERATION

GENERAL

The text in this section refers to circuit designations of unit A of the Model LPD suffix A power supply, however the discussion is equally applicable to unit B which has electrically identical components in the 100 series.

The Lambda power supply consists of an AC input circuit and transformer; a bias supply consisting of an auxiliary rectifier and filter, and preregulator; a main regulator circuit consisting of the main rectifier and filter, a series regulator, emitter follower driver(s), a current comparator, a voltage comparator, a voltage amplifier, current and voltage sensing networks and a voltage reference circuit.

The circuit arrangement is shown in block diagram form, Figure 11. The circuitry is discussed with reference to the block diagram and the schematic diagram.

FUNCTIONAL DESCRIPTION

Single phase input power is applied to transformer T1 through the input circuit containing a thermostat and fuse F1, which protect the supply against overheating and internal faults. Transformer T1 supplies secondary power for both unit A and unit B.

The main rectifier, a full-wave rectifier, provides the power which is filtered by capacitor C9 and then regulated via a series regulator and delivered to the output. Half-wave auxiliary rectifier CR1 provides voltage filtered by capacitor C2 for voltage amplifier Q4 and preregulator Q1. Preregulator Q1 provides regulated power for zener diode CR3, which is the reference element for the current sensing circuit, for current comparator Q2, Q3, voltage comparator Q5, Q6, and for Q7 and zener diode CR7, which together function as the voltage reference for constant voltage operation. CR8 provides voltage compensation which acts to reduce the effect of temperature changes on the emitter-base bias of Q7.

Constant voltage or constant current crossover circuit operation is determined by changes in the load. A change in the output voltage is sensed by voltage sensing divider R30A, B, which has a constant current of 5 milliamperes flowing in the divider element, determined by Q7 and the setting of calibration control R20. This output voltage variation causes a change to the input of Q6 of the voltage comparator, which compares it with the reference voltage developed across R30 A&B, resulting in an error signal at the output of Q5. In constant voltage operation, the voltage across R29 is less than the preset voltage across R6A, B; Q3 is in saturation, CR4 is at cutoff; and CR6 is conducting. If the load current decreases, causing a rise in output voltage, Q6 conducts more, Q5 is biased toward cutoff and more current from R18 flows through OR gate diode CR6 instead of Q5. This action causes amplifier Q4 to conduct more heavily, reducing drive current to the base of driver Q8, causing the series regulator impedance to increase and the output voltage to decrease accordingly.

Simultaneously, Q2 of the current comparator samples the load current through current sensing resistor R29 and compares it with the reference voltage across R6A, B, determined by zener diode CR3. In constant current operation, the voltage across R29 is approximately equal to the preset voltage across R6A, B, Q3 is biased toward cutoff, causing the current from R10 flow through OR gate diode CR4 and zener diode CR5. CR5 is used to offset DC power line voltage drops which occur when operating the unit with remote sensing. Similarly, this action will cause amplifier Q4 to conduct more heavily, reducing drive current to the base of Q8, causing the series regulator impedance to increase and the output voltage to decrease accordingly, effectively maintaining

a constant current. This output voltage decrease, sensed by the voltage sensing network, causes turn-on of Q5 till saturation occurs and OR gate diode CR6 stops conducting. The unit now continues to function in the constant current mode of operation, with OR gate diode CR4 controlling the turn-on bias of Q4, which in turn controls the drive current to the series regulator and ultimately the output voltage of the supply.

In models LPD-424AFM and LPD-425AFM tandem transistors Q9, Q11 are used to share the total series regulator voltage. Resistors R32 and R33 fix the base of Q10 at approximately one-half of the total series regulator voltage. The emitter current from Q10 controls tandem regulator Q11, which tracks with Q9 to split voltage and power.

OPERATING INSTRUCTIONS

CONTROLS, INSTRUMENTS AND FUSES

Power ON-OFF Switch. The power ON-OFF switch, located on the front panel, controls application of input power to both units A and B of the LPD suffix A supply. When the switch is in the ON position, the red power on indicator glows.

OUTPUT VOLTAGE Control. The OUTPUT VOLTAGE control is a dual control consisting of a coarse adjustment potentiometer, which varies the DC voltage over a range of 0-19, 0-39, 0-59 volts as applicable, and a fine adjustment potentiometer, which varies the DC voltage over a one-volt range*. Clockwise rotation results in increasing voltage. The total DC voltage output for voltage regulated operation is equal to the sum of each shaft setting; for current regulated operation the maximum voltage limit is equal to the sum of each shaft setting. The control is located on the front panel of all units.

*For models LPD-424AFM and LPD-425AFM output voltage control is a single ten turn control.

CURRENT LIMITER Control. The CURRENT LIMITER control is a dual control consisting of a coarse adjustment potentiometer, which varies the DC current over 90% of the rated current range* and a fine adjustment potentiometer, which varies the DC current over 10% of the rated current range**. Clockwise rotation results in increasing current. The total DC current output for current regulated operation, is equal to the sum of each shaft setting; for voltage regulated operation the maximum current limit is equal to the sum of each shaft setting. The control is located on the front panel of all units.

*Operation for output current below rated limits can result in no output or no regulation.

**For models LPD-424AFM and LPD-425AFM current limiter control is a single ten turn control.

Output Voltage Meter. A DC voltmeter monitors the voltage at the output terminals of all units for the rated voltage range.

Output Current Meter. A DC ammeter monitors the load output current of all units for the rated current range.

Fuses. Fuse F1, internally located, is a 3 ampere, 3AG "SLO-BLO" fuse which functions in the AC input circuit.

Fuse F2, internally located, provides protection against internal circuit failure. See Table IV for current ratings of pertinent F2 fuse.

Connection Terminals. Make all connections to the supply at the terminal blocks on the rear of the supply. DC output connections can also be made at the five-way binding posts located on the front panel of all models. Apply input power through the line cord or directly to terminals 1 and 2 if the line cord is removed. Always connect the ungrounded (hot) power lead to terminal 1.

The supply positive terminal is brought out to terminals 6 and 14. The supply negative terminal is brought out to terminals 4 and 12. Recommended wiring of the power supply to the load and selection of wiring is shown in figures 1 through 10. Selection of proper wiring is made on the basis of load requirements. Make all performance checks and measurements of current or voltage at the rear output terminals. Connect measuring devices directly to terminals or use the shortest leads possible.

GROUND CONNECTIONS

The Lambda power supply can be operated either with negative or positive output terminal grounded or with no terminal grounded. Both positive and negative ground connections are shown in the diagrams for all suggested output connections illustrated in this manual.

NOTE: When operating the supply with neither terminal grounded, high impedance leakage resistance and capacitance paths can exist between the power supply circuitry and chassis ground.

BASIC MODES OF OPERATION

This power supply is designed to operate as a constant voltage source or as a constant current source. Automatic crossover to either mode of operation occurs when load conditions change as follows:

Constant Voltage. The power supply will function as a constant voltage source while the load current does not equal the current value, I_{LIM} , set by the CURRENT LIMITER control. When load current $I_L = \frac{V}{R_L} = I_{LIM}$, the supply will cross over automatically

and will operate as a constant current source. Further decrease in value of load resistance R_L results in decrease of voltage across the load while current remains regulated to I_{LIM} .

Constant Current (Automatic Crossover). The power supply will function as a constant current source while the load voltage V_L does not equal the voltage value set by the OUTPUT VOLTAGE control. When load voltage V_L equals the value set by the OUTPUT VOLTAGE control, the supply will automatically cross over and operate as a constant voltage source.

SUPPLY LOAD CONNECTIONS

NOTE: Refer to DETAILED OPERATING PROCEDURES for step-by-step instructions for operation of power supply.

Connections For Operation as a Constant Voltage Source

The output impedance and regulation of the power supply at the load may change when using the supply as a constant voltage source and connecting leads of practical length are used. To minimize the effect of the output leads on these characteristics, remote sensing is used. Recommended types of supply-load connections with local or remote sensing are described in the following paragraphs.

Refer to figure 1 to determine voltage drop for particular cable length, wire size and current conditions. Lead lengths must be measured from supply terminals to load terminals as shown in figure 2.

Two-Wire Connection, Figure 3. The two-wire connection, with local sensing, is the connection suitable for application with relatively constant load.

Four-Wire Connection, Figure 4. The four-wire connection with remote sensing, provides complete compensation for the DC voltage drops in the connecting cables. Sensing leads should be twisted pair to minimize AC pick-up. A 2.5 mf, elect, capacitor may be required between output terminals and sense terminals to reduce noise pick-up.

Programmed Voltage Connections, Using External Resistor, Figure 5. Discrete voltage steps can be programmed with a resistance voltage divider valued at 200 ohms/volt and a shorting-type switch as shown in figure 5. When continuous voltage variations are required, use variable resistor with the same 200 ohms/volt ratio in place of the resistive voltage divider and shorting-type switch. Use a low temperature coefficient resistor to assure most stable operation.

As shown in figure 5, voltages can be programmed utilizing either local or remote sensing connections, as desired.

Programmed Voltage Connections Using Programming Voltage, Figure 6. The power supply voltage output can be programmed with an externally connected programming power supply. The output voltage of the programmed supply will maintain a one-to-one ratio with the voltage of the programming supply.

The programming supply must have a reverse current capability of 6 ma. minimum.

Alternatively, when supplies with less than 6 ma. reverse current capability are used, a resistor capable of drawing 6 ma. at the minimum programming voltage must be connected across the output terminals of the supply. This programming supply must be rated to handle all excess resistor current at the maximum programming voltage.

Connections For Operation as a Constant Current Source

Automatic Crossover Constant Current Connections, Figure 3. Figure 3 shows the connections which are used when operating the power supply as a constant current source with automatic crossover, using local setting of current control*

*Setting control for output currents below rated limits can result in no output or no regulation.

In this mode of operation, when the load voltage increases, due to changing load resistance, to the limit of the OUTPUT VOLTAGE control setting, the power supply crossover circuit will cause the unit to operate as a constant voltage supply.

Connections For Series Operation

The voltage capability of LPD suffix A power supplies can be extended by series operation of LPD suffix A power supplies of equal* voltage ratings. A maximum of 300 volts can be connected between either the +DC or -DC terminal and chassis ground, with a maximum voltage capability of 500 volts possible for model LPD-425AFM.

*For applications using supplies of unequal ratings, consult factory for details of operation.

This method permits operation for either constant voltage or constant current with automatic crossover to either mode of operation whenever the respective limiting operating current or voltage is reached. Figure 7 shows connection for either local or remote sensing in a series connection where the operating controls of each unit function independently to control the output, and where the B unit does not track the A unit.

Units A and B are shown connected for series operation in figures 8 and 9. Figure 8 shows the series connection diagram which would be suitable for use in all applications where tracking is desired but exact one-to-one voltage tracking of the "master" (A) unit by the "slave" (B) unit is not required. The slight offset in tracking is easily compensated for by adjusting the OUTPUT VOLTAGE controls on the (B) unit. This connection requires a minimum of 5 ma. load current*, R_{EXT} , calculated at 200ohms per volt, can be used for this purpose if desired.

Figure 9 shows the series connection diagram suitable for applications where exact one-to-one voltage tracking is required. In this series configuration, resistor R_{BAL} permits the (B) unit to track the (A) unit on an exact one-to-one basis, thereby eliminating the possibility of an offset voltage existing between the two units.

Resistor R_{BAL} should be a one-watt, 10-20 kilohm resistor. This value would permit wide-range compensation for manufacturing differences inherent in the components used in each unit. Resistors R_B and R_A function in the voltage sensing circuits of both units, enabling the (B) unit to reference its output voltage to that of the (A) unit. Select R_A and R_B on the basis of 200 ohm per volt of (A) unit output voltage. R_A must equal R_B . This connection also requires a minimum of 5 ma. load current *; R_{EXT} , calculated at 200 ohms per volt, can be used for this purpose if desired.

Capacitor C_B , used to eliminate stray AC pickup, is rated at 2.5 mfd, 200V for models LPD421AFM, 422AFM, 423AFM, and is rated at 1.4 mfd, 400V for models LPD424AFM, 425AFM.

Both series connection methods permit operation for either constant voltage or constant current with automatic crossover to either mode of operation whenever the respective limiting operating current or voltage is reached. As shown in figures 8 and 9, each method permits connection for either local or remote sensing.

* For other operating conditions, consult factory for details.

Connections For Parallel Operation

The current capability of LPD suffix A power supplies can be extended by parallel operation of LPD suffix A power supplies of equal* voltage capacities. Units "A" and "B" are shown connected for parallel operation in figure 10. One power supply designated the "master" or (A) unit controls its own output as well as the output of the second power supply, designated the "slave" or (B) unit.

* For applications using supplies of unequal voltage ratings, consult factory for details of operation.

Unit (B) operates to regulate its current in a ratio to that of the (A) unit by comparing the current in its internal sampling resistor with that current sampled by the master internal sampling resistor.

Parallel connected units can be operated for constant voltage with local sensing, figure 10A, or remote sensing, figure 10B, as well as for constant current with automatic crossover, figure 10A. When operating for constant voltage, the (A) unit can automatically cross over into constant current operation.

DETAILED OPERATING PROCEDURES

The text which follows, applies to both unit A and unit B of the LPD suffix A power supply.

SAFETY NOTICE

DANGEROUS VOLTAGES EXIST IN THIS EQUIPMENT. OBSERVE THE USUAL SAFETY PRECAUTIONS WHEN OPERATING OR SERVICING THE EQUIPMENT TO AVOID SHOCK OR INJURY

Constant Voltage Operation, Adjustable Current Limit

1. Remove AC power to the supply and place power ON-OFF switch in OFF position before connecting load to the supply.

2. Determine load requirements, select wire size from figures 1 and 2 and choose desired type of supply-load connection from figures 3 and 4.

3. Connect supply to load as shown on the selected connection diagram.

NOTE: When shipped from the factory, the supply is ready for use as a local-sensing constant voltage source with automatic cross over or as a constant current source. Jumpers are connected at the factory as shown in figure 3, Take care to remove the appropriate jumpers for load requirements that need different supply-load connections. Refer to the appropriate connection diagram.

4. Turn OUTPUT VOLTAGE control knobs to the desired voltage setting.

5. When current to the load must be limited to an intermediate value within the current rating of the supply, turn the CURRENT LIMITER controls to the desired current limit setting. If no intermediate current limit is required, turn the control CW to the position for full current rating for the maximum ambient temperature of operation. Refer to section on SPECIFICATIONS AND FEATURES.

6. Apply AC power to the supply.

7. Place power ON-OFF switch in ON position and check that red power ON indicator is lit.

8. Check that output current* and output voltage meters indicate desired values; as required, adjust OUTPUT VOLTAGE control knobs and CURRENT LIMITER controls to obtain correct meter indications. For remote sensing connections, check at the load terminations of sensing leads on terminals 3 (11) and 7 (15).

*Ammeter indicates a nominal 5 milliamperes offset from zero, which is the sensing divider current and not load current. For load current use the 5 ma. point as zero point.

9. Power supply is now in proper operation.

Programmed Constant Voltage Operation, Adjustable Current Limit

1. Remove AC power input to the supply and place power ON-OFF switch in OFF position before connecting load to the supply.
2. Determine load requirements, select wire size and length from figures 1 and 2 and choose desired type of supply-load connection from figures 5 or 6. Refer to paragraph on Programmed Voltage Connections.
3. Connect supply to load as shown on the selected connection diagram. As shown in figure 5, take care to use a shorting-type switch for the external programming control when several voltages are desired and the programming voltage method is not used. Select applicable value for capacitor C.
4. Turn OUTPUT VOLTAGE control knobs to the extreme CCW position. Adjust external programming voltage control to desired voltage setting.
5. When current to the load must be limited to an intermediate value within the current rating of the supply, turn the CURRENT LIMITER controls to the desired current limit setting. If no intermediate current limit is desired, turn the controls CW to the position for full rated current for the ambient temperature of operation. Refer to section on SPECIFICATIONS AND FEATURES.
6. Apply AC power to the supply.
7. Place power ON-OFF switch on ON position and check that red power ON indicator is lit.
8. Check that output current* and output voltage meters indicate desired values; as required, adjust CURRENT LIMITER controls and external programming voltage control to obtain correct meter indications. For remote sensing connections check at the load terminations of sensing leads on terminals 3 (11) and 7 (15).

*Ammeter indicates a nominal 5 milliamperes offset from zero, which is the sensing divider current and not load current. For load current use the 5 ma. point as zero point.

9. Power supply is now in proper operation.

Constant Current Operation With Crossover, Adjustable Voltage Limit

1. Remove AC power input to the supply and place power ON-OFF switch in OFF position before connecting load to the supply.
2. Determine load requirements, select wire size and length from figures 1 and 2 and connect load to the supply as shown in figure 3.
3. Turn the CURRENT LIMITER controls to the desired current setting.
4. When load voltage must be limited to an intermediate value within the voltage rating of the supply, turn OUTPUT VOLTAGE control knobs to the desired voltage limit setting. If no intermediate voltage limit, within rating of supply is desired, turn controls to the full CW position to obtain voltage limit at maximum voltage rating of the supply.

5. Apply AC power to the supply.
6. Place power ON-OFF switch in ON position and check that red power ON indicator is lit.
7. Check that output current* and output voltage meters indicate desired values; and just OUTPUT VOLTAGE control knobs and CURRENT LIMITER controls as required to obtain correct indications.

*Ammeter indicates a nominal 5 milliamperes offset from zero, which is the sensing divider current and not load current. For load current use the 5 ma. point as zero point.

8. Power supply is now in proper operation.

Series Connection Constant Voltage Operation, With Current Limit

1. Remove AC power input to supply and place power ON-OFF switch in OFF position before connecting load to the supplies.

2. Determine load requirements, select wire size from figures 1 and 2, choose correct type of series supply-load connection from figures 7-9 and connect accordingly. Refer to paragraph on Connections for Series Operation.

3. As required select R_A , R_B , R_{BAL} , R_{EXT} in accordance with instructions contained in Connections for Series Operation and connect in accordance with appropriate connection diagram.

4. Set output voltage for the combination as follows:

- (a) If figure 7 connection was chosen, turn OUTPUT VOLTAGE control knobs of both unit A and B to obtain the desired output voltage. These settings must add up to be the output voltage for the combination.
- (b) If figure 8 connection was chosen, disconnect load from supply. Apply AC power input, and place power ON-OFF switch in ON position. Set OUTPUT VOLTAGE controls of (A) unit for maximum rated voltage, then set OUTPUT VOLTAGE controls of (B) unit for the same position. Turn A unit OUTPUT VOLTAGE controls until combined voltmeter indications total the desired output voltage for the combination. Place power ON-OFF switch in OFF position and connect load to the supply.
- (c) If figure 9 connection was chosen, turn OUTPUT VOLTAGE control knobs of unit A to a setting that is approximately one-half of the desired output voltage for the combination. Turn (B) unit OUTPUT VOLTAGE control knobs and CURRENT LIMITER control knobs to extreme CW position.

5. When current to the load must be limited to an intermediate value within current rating of the units, proceed as follows:

When figure 7, 8, or 9 connection is chosen, turn CURRENT LIMITER control knobs of each unit to a setting equal to desired total current limit for the

combination; offset the (B) unit control to a position slightly more than the total current limit for the combination.

If no intermediate current limit is required, turn the CURRENT LIMITER control knobs of each unit CW to the position for full current rating for the maximum ambient temperature of operation. Refer to section on SPECIFICATIONS AND FEATURES.

6. Apply AC power to the supplies.

7. Place power ON-OFF switches of both units in ON position and check that red power ON indicators are lit.

8. Check that output current* and output voltage meters indicate desired values; total voltage is equal to sum of output voltage of both units. As required, adjust OUTPUT VOLTAGE control knobs and CURRENT LIMITER controls of the appropriate units to obtain correct indications.

*Ammeter indicates a nominal 5 milliamperes offset from zero, which is the sensing divider current and not load current. For load current use the 5 ma. point as zero point.

For remote sensing connection, make checks at the load terminations of sensing leads from terminal 7 of unit (A) and from terminal 11 of unit (B) when figure 7 and 8 connections are used, or from terminal 7 of unit (A) and from R_B connection at the load when figure 9 connection is used.

Series Connection Constant Current Operation, With Voltage Limit

1. Remove AC power input to supply and place power ON-OFF switch in OFF position before connecting load to the supplies.

2. Determine load requirements, select wire size from figures 1 and 2, choose correct type of series supply-load connections from figures 7A, 8A and 9A and make supply-load connections as shown on selected figure. Refer to paragraph on Connections for Series Operation.

3. As required select resistors R_{BAL} , R_A , R_B , and R_{EXT} as instructed in Connections for Series Operation paragraph.

4. If figure 7A is used, turn CURRENT LIMITER controls of each unit to the desired total current limit setting. If figure 8A or 9A is used, turn CURRENT LIMITER controls of (A) unit to total current limit setting and the CURRENT LIMITER controls of (B) unit to a position slightly higher than total current setting.

5. When load voltage must be limited to an intermediate value within the voltage rating of the series combination, turn the OUTPUT VOLTAGE control knobs to a position for total intermediate voltage required for the combination. Total voltage is the sum of the voltage settings of each unit when figure 7A is used. For figures 8A or 9A, set OUTPUT VOLTAGE control of (A) unit to approximately one-half the total voltage limit desired, and adjust VOLTAGE control of (B) unit to equal the setting indicated by the (A) unit VOLTAGE controls.

If no intermediate voltage limit is required, turn the controls to the full CW position to obtain voltage limit at the maximum combined ratings of the supplies.

6. Apply AC power to the supplies.

7. Place power ON-OFF switches of both units to ON position and check that red power ON indicators are lit.

8. Check that output current* and output voltage meters indicate desired values; total voltage is the sum of (A) and (B) unit voltages. As required, adjust OUTPUT VOLTAGE control knobs and CURRENT LIMITER controls of appropriate units to obtain correct indications.

*Ammeter indicates a nominal 5 milliamperes offset from zero, which is the sensing divider current and not load current. For load current use the 5 ma. point as zero point.

9. Power supplies are now in proper operation.

Parallel Connection Constant Voltage Operation, With Current Limit

1. Remove AC power input to supply and place power ON-OFF switch in OFF position before connecting load to the supplies.

2. Determine load requirements, select wire size from figures 1 and 2 in the manual. Refer to paragraph on Connections for Parallel Operation.

3. Connect supplies to load as shown in connection diagram, figure 10A, for local sensing, or figure 10B for remote sensing.

NOTE: When shipped from the factory, each supply is ready for use as a local-sensing constant voltage source with automatic crossover or as a constant current source. Jumpers are connected at the factory as shown in figure 3. Take care to remove the appropriate jumpers for load requirements that need different supply-load connections. Refer to the connection diagram.

4. Turn OUTPUT VOLTAGE control knobs on the (A) unit to the desired voltage setting, and turn the OUTPUT VOLTAGE controls on the (B) unit to fully CCW position.

5. When current to the load must be limited to an intermediate point, turn the CURRENT LIMITER controls on both the (A) and (B) units to the desired current limit setting. Set current limit control on the (A) and (B) units to the position indicating the current value to be delivered by the respective unit. If no intermediate current limit is desired, turn the controls CW on both (A) and (B) units to the position for full rated current for the maximum ambient temperature of operation. Refer to section on SPECIFICATIONS AND FEATURES.

6. Apply AC power to each supply.

7. Place power ON-OFF switch in ON position and check that red power ON indicator is lit.

8. Check that output current* and output voltage meters on both (A) and (B) units indicate desired values; as required, adjust OUTPUT VOLTAGE controls and CURRENT LIMITER

controls on (A) unit to obtain correct meter indications. For remote sensing connection check at the load termination of sensing leads on terminals 3 and 7 of the (A) unit.

*Ammeter indicates a nominal 5 milliamperes offset from zero, which is the sensing divider current and not load current. For load current use the 5 ma. point as zero point.

9. Power supplies are now in proper operation.

Parallel Connection Constant Current Operation, With Voltage Limit

1. Remove AC power input to supply and place power ON-OFF switch in OFF position before connecting load to the supplies.

2. Determine load requirements, select wire size from figures 1 and 2 and connect load to the supplies as shown in figure 10A. Refer to paragraph on Connections for Parallel Operation.

3. Turn the CURRENT LIMITER control knobs on (A) unit to the desired current setting. Turn OUTPUT VOLTAGE control knobs on the (B) unit to full CCW position.

NOTE: When setting the CURRENT LIMITER knobs on the (A) and (B) units take care to set the control so that each unit indicates the proportion of total current that the unit must supply.

4. When load voltage must be limited, turn OUTPUT VOLTAGE control knobs on the (A) unit to the desired voltage limit setting. If no voltage limit within rating of the supply is desired, turn controls on the (A) unit to the full CW position.

5. Apply AC power to supply.

6. Place power ON-OFF switch in ON position and check that red power ON indicator is lit.

7. Check that output current* and output voltage meters on both units indicate desired values; adjust OUTPUT VOLTAGE controls and CURRENT LIMITER controls, as required, to obtain correct indications.

*Ammeter indicates a nominal 5 milliamperes offset from zero, which is the sensing divider current and not load current. For load current use the 5 ma. point as zero point.

8. Power supplies are now in proper operation.

OPERATION AFTER PROTECTIVE DEVICE SHUTDOWN

Thermostat Shutdown

The thermostat opens the input circuit only when the temperature of the internal chassis exceeds a maximum safe value. The thermostat will automatically reset when the temperature of the internal chassis decreases to safe operating value. After eliminating the cause(s) for overheating and allowing time for the power supply to cool to a proper temperature, resume operation of the supply. Refer to appropriate operation paragraph in DETAILED OPERATING PROCEDURES.

Fuse Shutdown

Internal component failure is prevented by fuses which protect the components from damage caused by excessive currents. Fuses will blow when the maximum rated current value for the fuse is exceeded. Fatigue failure of fuses can occur when mechanical vibrations from the installation combine with thermally induced stresses to weaken the fuse metal. Many fuse failures are caused by a temporary condition and replacing the blown fuse will make the fuse protected circuit operative. When the LPD suffix A supply is used with the overvoltage protector option, fuse F2 will provide protection against internal component failure.

MAINTENANCE

GENERAL

This section describes trouble analysis routine, replacement procedures, calibration and test procedures that are useful for servicing the Lambda LPD suffix A power supply. A trouble chart is provided as an aid for the troubleshooter. The text of the trouble chart refers to component designations of unit (A) of the LPD suffix A supply, but it is equally applicable for unit (B) which has identical components designated in the 100 series. Refer to the section on specifications and features for the minimum performance standards.

TROUBLE ANALYSIS

Whenever trouble occurs, systematically check all fuses, primary power lines, external circuit elements, and external wiring for malfunction before trouble shooting the equipment. Failures and malfunctions often can be traced to simple causes such as improper jumper and supply-load connections or fuse failure due to metal fatigue.

Use the electrical schematic diagram and block diagram, figure 11, as an aid to locating trouble causes. The schematic diagram contains various circuit voltages that are averages for normal operation. Measure these voltages using the conditions for measurement specified on the schematic diagram. Use measuring probes carefully to avoid causing short circuits and damaging circuit components.

CHECKING TRANSISTORS AND CAPACITORS

Check transistors with an instrument that has a highly limited current capability. Observe proper polarity for PNP or NPN to avoid error in measurement. The forward transistor resistance is low but never zero; backward resistance is always higher than the forward resistance.

For good transistors, the forward resistance for any junction is always greater than zero.

Do not assume trouble is eliminated when only one part is replaced. This is especially true when one transistor fails, causing other transistors to fail. Replacing only one transistor and turning power on, before checking for additional defective components could damage the replaced component.

When soldering semi-conductor devices, wherever possible, hold the lead being soldered with a pair of pliers placed between the component and the solder joint to provide an effective heat sink.

NOTE: The leakage resistance obtained from a simple resistance check of a capacitor is not always an indication of a faulty capacitor. In all cases the capacitors are shunted with resistances, some of which have low values. Only a dead short is a true indication of a shorted capacitor.

PRINTED CIRCUIT BOARD MAINTENANCE TECHNIQUES

1. If foil is intact but not covered with solder it is a good contact. Do not attempt to cover with solder.

2. Voltage measurements can be made from either side of the board. Use a needle-point probe to penetrate to the wiring whenever a protective coating is used on the wiring. A brass probe can be soldered to an alligator clip adapted to the measuring instrument.

3. Wherever possible use a heat sink when soldering transistors.

4. Broken or damaged printed wiring is usually the result of an imperfection, strain or careless soldering. To repair small breaks, tin a short piece of hook-up wire to bridge the break, and holding the wire in place, flow solder along the length of wire so that it becomes part of the circuitry.

5. When unsoldering components from the board never pry or force loose the part; unsolder the component by using the wicking process described below:

(a) Select a 3/16 inch tinned copper braid for use as a wick; if braid is not available, select AWG No. 14 or No. 16 stranded wire with 1/2 inch insulation removed.

(b) Dip the wick in liquid rosin flux.

(c) Place the wick onto the soldered connection and apply soldering iron onto the wick.

(d) When sufficient amount of solder flows onto the wick, freeing the component, simultaneously remove iron and wick.

TROUBLE CHART

The trouble chart is intended as a guide for locating trouble causes, and is used along with the schematic diagram. When troubleshooting the (B) unit, add 100 to the component designations in the trouble chart.

The operating conditions assumed for the trouble chart are as follows:

(a) AC power of proper voltage and frequency is present at input terminals.

(b) Either positive or negative terminal is connected to chassis ground.

(c) The power supply is connected for constant voltage with local sensing. See schematic; dotted lines indicate jumpers connected for local sensing operation.

TROUBLE SHOOTING CHART

<u>Symptom</u>	<u>Probable Cause</u>	<u>Remedy</u>
1. Power ON lamp DS1 does not light with power ON-OFF switch in ON position; no output voltage	No power input; power ON-OFF switch S1 defective fuse F1; thermostat open, fuse F1 blown	Check power source, line cord and line cord plug; replace S1; replace F1; shut off unit, allow to cool and check ambient temperature
		Replace F1; if it blows immediately, check diodes CR20, CR21 or as applicable CR12, CR13, CR16, CR17, CR20, CR21, CR25, CR26 and capacitor C9, replace as necessary
2. Unable to adjust output voltage	Damaged OUTPUT VOLTAGE controls	Check R30A and R30B for shorts and/or open, replace as necessary
	Supply operating as constant current source with crossover at CURRENT LIMITER setting	Remove load and check for shorts and/or improper supply-load connections; refer to appropriate diagram for correct connections
3. Zero volts DC output, with power ON indicator lit	OUTPUT VOLTAGE controls turned fully CCW	Check OUTPUT VOLTAGE controls for proper setting and correct as necessary
	Short circuit across output of supply	Check load and load connections, correct as necessary
	Check F2 for open	Replace F2 as necessary
	Series regulator section open	Check Q9, and, as applicable, Q11 for open, replace as necessary
	Open Q2, CR14, CR15, CR18, CR19 as applicable	Check Q2, CR14, CR15, CR18, CR19 as applicable for open, replace as necessary
	Emitter follower(s) open	Check Q8 and as applicable Q10 for open, replace as necessary
	Current sensing resistor open, or, as applicable, emitter resistors R35, R41 open	Check R29 for open; replace as necessary; as applicable check R35, R41 for open and replace as required

TROUBLE SHOOTING CHART (cont'd)

<u>Symptom</u>	<u>Probable Cause</u>	<u>Remedy</u>
(step 3 cont'd)	Improper voltage reference as indicated by voltage measurement across R20-R21 and CR7; aux. rectifier CR1 open	Check Q7 for open, CR8 and CR7 for short or CR1 for open; replace as necessary
4. High ripple at line frequency or twice line frequency and unregulated DC output	Series regulator transistors shorted emitter followers shorted; voltage amplifier open	Check and replace as necessary: Q9, Q11, Q8, Q10; Q4
	Defective main rectifier causes ripple at twice line frequency	Check as applicable CR20, CR21 (CR12) (CR13) (CR16) (CR17) (CR25) (CR26), in addition to Q4; Q8 (Q10); Q9, (Q11)
5. Same as 4, except intermitten	Foreign matter fallen into unit	Check for loose bench hardware and wire clippings that may have fallen through cover.
6. High ripple at frequency other than line or twice line frequency	Oscillation due to defective component in filter network	Check for open C12, C13 and check for open and/or short in R14 and C6, R8 and C3, C5 and R22 networks and replace defective component
7. Large spikes at output	Capacitor C1, (C14) open	Replace C1, as necessary, or C14 as applicable

ADJUSTMENT OF CALIBRATION CONTROLS

Whenever parts are replaced, adjust calibration controls only when voltage and current indications are improper and do not reflect maximum ratings.

Adjust Voltage Calibration Control R20 (R120) as Follows:

1. Remove AC power input to the supply and place power ON-OFF switch in OFF position.
2. Unsolder wiper of R20 (R120) from resistor housing.
3. Operate the power supply for constant voltage with local-sensing jumpers connected as shown in figure 3, and no external load.
4. Turn OUTPUT VOLTAGE control knobs fully clockwise and, using a DC voltmeter of one percent accuracy or better, adjust R20 (R120) to provide output voltage $E_O \text{ MAX} + 25^\circ\text{C}$ ambient; where $E_O \text{ MAX}$ is rated output voltage of the supply.
5. After adjustment is completed, remove AC power input to the supply and solder wiper of R20 (R120) to potentiometer housing.

Adjust Current Calibration Control R4 (R104) as follows:

1. Remove AC power input to the supply and place power ON-OFF switch in OFF position.
2. Unsolder wiper of R4 (R104) from resistor housing.
3. Turn OUTPUT VOLTAGE control knobs and CURRENT LIMITER controls fully CW.
4. Operate the power supply for constant current crossover, connected as shown in figure 3, with a short circuit across the output terminals.
5. Adjust R4 (R104) for 105% of full current rating at 30°C ambient, using any DC ammeter of one percent accuracy or better.
6. After adjustment is completed, remove AC power input to the supply and solder wiper of R4 (R104) to potentiometer housing.

PERFORMANCE CHECKS

Checks With Constant Voltage Operation

Check the ripple and regulation of the power supply using the test connection diagram shown in figure 12. Use suggested test equipment or equivalent to obtain accurate results. Refer to SPECIFICATIONS AND FEATURES for minimum performance standards.

Set the differential meter, DC VTVM (John Fluke Model 871A or equivalent) to the selected power supply operating voltage. Check the power supply load regulation accuracy while switching from the load to no-load condition. Long load leads should be a twisted pair to minimize AC pick-up.

Use a Variac to vary the line voltage from 105-132 or 132-105 volts AC and check the power-supply line regulation accuracy on the VTVM differential meter.

Use a VTVM, Ballantine 320 or equivalent, to measure rms ripple voltage of the power supply DC output. Use oscilloscope to measure peak-to-peak ripple voltage of the power supply DC output.

Check With Constant Current Operation

Check the ripple or regulation of the power supply using the test connection diagram shown in figure 13. When checking, refer to SPECIFICATIONS AND FEATURES for minimum performance standards.

Check the power supply load regulation accuracy while switching from the short circuit to load condition. Measure the voltage across sensing resistor R_s . Use John Fluke Model 871A or equivalent for the VTVM connected across R_s . For R_s , use a resistor having the same value as resistor R29 (R129) in the unit being tested. To obtain regulation figure, substitute values obtained into regulation formula:

$$\frac{\Delta E}{R_s} = \text{Regulation in milliamperes,}$$

where ΔE is the voltage change in millivolts and R_s is the resistance of the sensing resistor

Use a Variac to vary the line voltage from 105-132 or 132-105 volts AC and check the power supply line regulation accuracy using VTVM and the regulation formula:

$$\frac{\Delta E}{R_s}$$

To measure rms ripple current of the power supply DC output, use a Ballantine Model 320 or equivalent meter and obtain ripple current I_r by substituting measured values into formula:

$$\frac{\text{V.A.C. rms}}{R_s} = I_r$$

SERVICE

When additional instructions are required or repair service is desired, contact the nearest Lambda office where trained personnel and complete facilities are ready to assist you.

Please include the power supply model and serial number together with complete details of the problem. On receipt of this information, Lambda will supply service data or advise shipping for factory repair service.

All repairs not covered by the warranty will be billed at cost and an estimate forwarded for approval before work is started.

PARTS ORDERING

Standard components and special components used in the Lambda power supply can be obtained from the factory. In case of emergency, critical spare parts are available through any Lambda office.

The following information must be included when ordering parts:

1. Model number and serial number of power supply and purchase date.
2. Lambda part number.
3. Description of part together with circuit designation.
4. If part is not an electronic part, or is not listed, provide a description, function, and location of the part.

PARTS LIST

The electrical parts located on Lambda models LPD-421A-FM — LPD-425-A-FM are listed here. Parts for unit A and B are listed separately by unit. Parts common to a group of models are listed first. Unique parts of individual models within the group are listed separately, by model, immediately following the group common-parts listing. In addition there are separate listings for the "V" option and LHOV accessory.

<u>COMMON PARTS</u>		
<u>MODELS LPD-421A-FM — LPD-425A-FM UNIT A</u>		
<u>CIRC. DESIG.</u>	<u>DESCRIPTION</u>	<u>LAMBDA NO.</u>
C1	Cap., mylar, 0.0033 mf ±10%, 200 vdc	CGK-33-003
C2	Cap., elect., 75 mf -10+100%, 55 vdc	CBP-75-009
C3	Cap., mylar, 0.001 mf ±10%, 200 vdc	CGK-10-004
C4	Cap., mylar, 0.1 mf ±10%, 80 vdc	CGM-10-006
C5	Cap., mylar, 0.00056 mf ±10%, 200 vdc	CGJ-56-001
C6	Cap., mylar, 0.01 mf ±20%, 80 vdc	CGL-10-008
C7, C8	Not assigned	
C10	Cap., mylar, 0.033 mf ±10%, 400 vdc	CGL-33-006
CR1	Rectifier	FBL-00-030
CR2	Rectifier, zener diode	FBM-Z119
CR3	Rectifier, zener diode	FBM-Z115
CR4	Same as CR1	
CR5	Rectifier, zener diode	FBM-Z121
CR6	Same as CR1	
CR7	Rectifier, zener diode	FBM-Z104
CR8, CR9	Same as CR1	
CR10	Not assigned	
CR11	Same as CR1	
CR14	Not assigned	
DS1	Pilot light	HRD-00-013
F1	Fuse, 3A, 3AG, SLO-BLO	FFC-03-000
Q1	Transistor, PNP	FBN-L103
Q2	Transistor, PNP	FBN-L119
Q3	Transistor, NPN	FBN-L120
thru Q5		
Q6, Q7	Same as Q2	
R1	Res., comp., 120 ohms ±5%, ½ w	DEB-1215
R2	Res., film, 910 ohms ±5%, ½ w	DCR-91-008

<u>COMMON PARTS (Cont.)</u>		
<u>MODELS LPD-421A-FM — LPD-425A-FM UNIT A (Cont.)</u>		
<u>CIRC. DESIG.</u>	<u>DESCRIPTION</u>	<u>LAMBDA NO.</u>
R3	Res., comp., 2,200 ohms ±10%, ½ w	DEB-2221
R4	Res., var., ww, 5,000 ohms ±10%, 1½ w	DNS-50-015
R5	Res., film, 1,000 ohms ±5%, ½ w	DCS-10-019
R7	Same as R3	
R8	Res., comp., 1,200 ohms ±10%, ½ w	DEB-1221
R9	Res., comp., 75,000 ohms ±5%, ½ w	DEB-7535
R10	Res., comp., 5,100 ohms ±5%, ½ w	DEB-5125
R11, R12	Not assigned	
R13	Res., comp., 39,000 ohms ±10%, ½ w	DEB-3931
R14	Res., comp., 470 ohms ±10%, ½ w	DEB-4711
R15	Res., comp., 6,800 ohms ±10%, ½ w	DEB-6821
R16, R17	Not assigned	
R18	Same as R10	
R19	Same as R9	
R20	Res., var., cermet, 600 ohms ±10%, 1 w	DRR-60-006
R21	Res., ww, 910 ohms ±3%, 3 w	DFR-91-069
R22	Res., comp., 1,000 ohms ±10%, ½ w	DEB-1021
R23	Res., comp., 10,000 ohms ±10%, ½ w	DEB-1031
R24	Res., film, 560 ohms ±2%, ½ w	DCR-56-002
R25	Not assigned	
R28	Same as R22	
R36, R37	Not assigned	
R38	Same as R22	
R40	Same as R23	

COMMON PARTS (Cont.)

MODELS LPD-421A-FM — LPD-425A-FM UNIT A (Cont.)

CIRC. DESIG.	DESCRIPTION	LAMBDA NO.
R45, R47, R48	Not assigned	
S1	Switch, SPST	FDA-11-040
S2	Thermostat	FKA-124-013
XF1, XF2	Fuse clip (2 req'd. per fuse)	HRM-00-005

UNIQUE PARTS

MODEL LPD-421A-FM UNIT A

C9	Cap., elect., 1,500 mf -10+100%, 40 vdc	CBS-15-056
C11	Cap., elect., 400 mf -10+100%, 30 vdc	CBR-40-034
C12	Cap., elect., 3 mf -10+75%, 100 vdc	CBN-30-015
C13	Cap., mylar, 0.47 mf ±10%, 200 vdc	CGM-47-009
C14	Cap., paper, 0.1 mf ±10%, 200 vdc	CAM-10-012
CR12, CR13, CR15 thru CR17	Not assigned	
CR18	Rectifier	FBL-00-047
thru CR21		
CR22	Not assigned	
CR23	Same as CR18	
CR24	Not assigned	
CR25, CR26	Same as CR18	
F2	Fuse, 4A, 3AG, Fast Acting	FFB-04-000
M1	Voltmeter, 0-20V	EBP-20-041
M2	Ammeter, 0-2A	EDN-20-036
Q8	Transistor, NPN	FBN-L109
Q9	Transistor, NPN	FBN-36220
Q10	Not assigned	
Q11	Same as Q9	
R6	Res., dual, var., ww, 500 ohms ±5%, 3w/50 ohms ±5%, 2w	DNR-55-024
R26	Res., comp., 560 ohms ±10%, ½ w	DEB-5611
R27	Res., comp., 3,300 ohms ±10%, ½ w	DEB-3321
R29	Res., ww, 1 ohm ±3%, 7 w	DFN-10-061
R30	Res., dual, var., ww, 3,800 ohms ±5%, 2w/200 ohms ±5%, 2w	DNS-40-061
R31	Res., ww, 220 ohms ±3%, 3w	DFR-22-072
R32 thru R34	Not assigned	
R35	Res., ww, 1 ohm ±3%, 3 w	DFN-10-041
R39	Res., comp., 8,200 ohms ±10%, 1 w	DGB-8221
R41	Same as R35	
R42	Not assigned	
R43	Res., ww, 500 ohms ±3%, 7 w	DFR-50-070
R44, R46	Not assigned	
T1	Transformer	ABA-421

UNIQUE PARTS (Cont.)

MODEL LPD-422A-FM UNIT A

CIRC. DESIG.	DESCRIPTION	LAMBDA NO.
C9	Cap., elect., 500 mf -10+100%, 75 vdc	CBR-50-056
C11	Cap., elect., 70 mf -10+100%, 90 vdc	CBP-70-012
C12	Cap., elect., 3 mf -10+75%, 100 vdc	CBN-30-015
C13	Cap., mylar, 0.47 mf ±10%, 200 vdc	CGM-47-009
C14	Cap., mylar, 0.018 mf ±10%, 200 vdc	CGL-18-005
CR12, CR13	Rectifier	FBL-00-036
CR15	Not assigned	
CR16,	Same as CR12	
CR17		
CR18,	Rectifier	FBL-00-047
CR19		
CR20	Not assigned	
thru CR22		
CR23	Same as CR18	
F2	Fuse, 3A, 3AG, Fast Acting	FFB-03-000
M1	Voltmeter, 0-40V	EBP-40-042
M2	Ammeter, 0-1A	EDN-10-034
Q8	Transistor, NPN	FBN-L108
Q9	Transistor, NPN	FBN-36605
Q10	Not assigned	
Q11	Same as Q9	
R6	Res., dual, var., ww, 500 ohms ±5%, 3w/50 ohms ±5%, 2w	DNR-55-024
R26	Res., comp., 330 ohms ±10%, ½ w	DEB-3311
R27	Res., comp., 3,300 ohms ±10%, ½ w	DEB-3321
R29	Res., ww, 2 ohms ±3%, 3 w	DFN-20-009
R30	Res., dual, var., ww, 7,800 ohms ±5%, 2 w/ 200 ohms ±5%, 2 w	DNS-80-062
R31	Res., ww, 220 ohms ±3%, 3 w	DFR-22-072
R32 thru R34	Not assigned	
R35	Same as R29	
R39	Res., comp., 12,000 ohms ±10%, 1 w	DGB-1231
R41	Same as R29	
R42	Not assigned	
R43	Res., ww, 1,650 ohms ±5%, 5 w	DFS-16-024
R44, R46	Not assigned	
T1	Transformer	ABA-422

MODEL LPD-423A-FM UNIT A

C9	Cap., elect., 310 mf -10+100%, 110 vdc	CBR-31-054
C11	Cap., elect., 70 mf -10+100%, 90 vdc	CBP-70-012
C12	Cap., elect., 3 mf -10+75%, 100 vdc	CBN-30-015
C13	Cap., mylar, 0.47 mf ±10%, 200 vdc	CGM-47-009
C14	Cap., mylar, 0.018 mf ±10%, 200 vdc	CGL-18-005
CR12, CR13	Rectifier	FBL-00-036
CR15	Not assigned	
CR16,	Same as CR12	
CR17		

UNIQUE PARTS (Cont.)
MODEL LPD-423A-FM UNIT A (Cont.)

<u>CIRC. DESIG.</u>	<u>DESCRIPTION</u>	<u>LAMBDA NO.</u>
CR18, CR19	Rectifier	FBL-00-047
CR20 thru CR23	Not assigned	
CR24	Same as CR12	
CR25, CR26	Not assigned	
CR27	Rectifier	FBL-00-096
F2	Fuse, 1.5A, 3AG, Fast Acting	FFB-01-500
M1	Voltmeter, 0-60V	EBP-60-043
M2	Ammeter, 0-1A	EDN-10-034
Q8	Transistor, NPN	FBN-L108
Q9	Transistor, NPN	FBN-35902
Q10	Not assigned	
Q11	Same as Q9	
R6	Res., dual, var., ww, 500 ohms $\pm 5\%$, 2w/50 ohms $\pm 5\%$, 2w	DNR-55-024
R26	Res., comp., 150 ohms $\pm 10\%$, $\frac{1}{2}$ w	DEB-1511
R27	Res., comp., 3,300 ohms $\pm 10\%$, $\frac{1}{2}$ w	DEB-3321
R29	Res., ww, 2.7 ohms $\pm 2\%$, 3 w	DFN-27-053
R30	Res., dual, var., ww, 11,800 ohms $\pm 5\%$, 2 w/200 ohms $\pm 5\%$, 2 w	DNT-12-033
R31	Res., ww, 750 ohms $\pm 3\%$, 3 w	DFR-75-085
R32 thru R34	Not assigned	
R35	Same as R29	
R39	Res., comp., 33,000 ohms $\pm 10\%$, 1 w	DGB-3331
R41	Same as R29	
R42	Not assigned	
R43	Res., ww, 3,500 ohms $\pm 3\%$, 5 w	DFS-35-071
R44, R46	Not assigned	
R49	Res., comp., 1,000 ohms $\pm 10\%$, $\frac{1}{4}$ w	DCB-1021
T1	Transformer	ABA-423

MODEL LPD-424A-FM UNIT A

C9	Cap., elect., 140 mf -10+100%, 200 vdc	CBR-14-055
C11	Cap., elect., 30 mf -10+100%, 250 vdc	CBP-30-017
C12	Cap., elect., 1.4 mf -10+100%, 400 vdc	CBN-14-022
C13	Cap., mylar, 0.033 mf $\pm 10\%$, 400 vdc	CGL-33-006
C14	Cap., mylar, 0.01 mf $\pm 10\%$, 600 vdc	CGL-10-010
CR12, CR13, CR15 thru CR17	Rectifier	FBL-00-033
CR18 thru CR21	Not assigned	
CR22	Same as CR12	
CR23	Not assigned	
CR24	Same as CR12	
CR25, CR26	Not assigned	

UNIQUE PARTS (Cont.)
MODEL LPD-424A-FM UNIT A (Cont.)

<u>CIRC. DESIG.</u>	<u>DESCRIPTION</u>	<u>LAMBDA NO.</u>
CR27	Rectifier	FBL-00-096
F2	Fuse, 1A, 3AG, Fast Acting	FFB-01-000
M1	Voltmeter, 0-120V	EBR-12-087
M2	Ammeter, 0-0.5A	EDM-50-047
Q8	Transistor, NPN	FBN-L115
Q9	Transistor, NPN	FBN-35902
Q10	Same as Q8	
Q11	Same as Q9	
R6	Res., var., ww, 500 ohms $\pm 5\%$, 5w	DNR-50-013
R26	Res., comp., 220 ohms $\pm 10\%$, $\frac{1}{2}$ w	DEB-2211
R27	Not assigned	
R29	Res., ww, 5 ohms $\pm 3\%$, 5 w	DFN-50-025
R30	Res., var., ww, 24,000 ohms $\pm 5\%$, 2w	DNT-24-071
R31	Res., ww, 750 ohms $\pm 3\%$, 3 w	DFR-75-085
R32, R33	Res., comp., 75,000 ohms $\pm 5\%$, $\frac{1}{2}$ w	DEB-7535
R34	Same as R26	
R35, R39, R41	Not assigned	
R42	Res., comp., 270,000 ohms $\pm 10\%$, 1 w	DGB-2741
R43	Not assigned	
R44	Res., comp., 5,100 ohms $\pm 5\%$, $\frac{1}{2}$ w	DEB-5125
R46	Same as R32	
R49	Res., comp., 1,000 ohms $\pm 10\%$, $\frac{1}{4}$ w	DCB-1021
T1	Transformer	ABA-424

MODEL LPD-425A-FM UNIT A

C9	Cap., elect., 45 mf -10+100%, 400 vdc	CBP-45-028
C11	Cap., elect., 8 mf -10+100%, 400 vdc	CBN-80-021
C12	Cap., elect., 1.4 mf -10+100%, 400 vdc	CBN-14-022
C13	Cap., mylar, 0.033 mf $\pm 10\%$, 400 vdc	CGL-33-006
C14	Cap., paper, 0.01 mf $\pm 10\%$, 1000 vdc	CAL-10-021
CR12, CR13	Rectifier	FBL-00-050
CR15	Rectifier	FBL-00-064
CR16, CR17	Same as CR12	
CR18 thru CR21	Not assigned	
CR22	Rectifier	FBL-00-033
CR23	Not assigned	
CR24	Same as CR15	
CR25, CR26	Not assigned	
CR27	Rectifier	FBL-00-096
F2	Fuse, $\frac{1}{4}$ A, 3AG, Fast Acting	FFB-00-250
M1	Voltmeter, 0-250V	EBR-25-088
M2	Ammeter, 0-0.15A	EDM-15-048
Q8	Transistor, NPN	FBN-L115
Q9	Transistor, NPN	FBN-38982
Q10	Same as Q8	
Q11	Same as Q9	

UNIQUE PARTS (Cont.)
MODEL LPD-425A-FM UNIT A (Cont.)

<u>CIRC. DESIG.</u>	<u>DESCRIPTION</u>	<u>LAMBDA NO.</u>
R6	Res., var., ww, 500 ohms ±5%, 5 w	DNR-50-013
R26	Res., comp., 150 ohms ±10%, ½ w	DEB-1511
R27	Not assigned	
R29	Res., ww, 16 ohms ±3%, 3 w	DFP-16-033
R30	Res., var., ww, 50,000 ohms ±5%, 2w	DNT-50-070
R31	Res., ww, 750 ohms ±3%, 3 w	DFR-75-085
R32, R33	Res., comp., 150,000 ohms ±5%, ½ w	DEB-1545
R34	Same as R26	
R35, R39, R41	Not assigned	
R42	Res., comp., 470,000 ohms ±10%, 1 w	DGB-4741
R43	Not assigned	
R44	Res., comp., 5,100 ohms ±5%, ½ w	DEB-5125
R46	Res., comp., 75,000 ±5%, ½ w	DEB-7535
R49	Res., comp., 1,000 ohms ±10%, ¼ w	DCB-1021
T1	Transformer	ABA-425

PARTS FOR MODELS
LPD-421A-FM — LPD-425A-FM UNIT B

Parts for Unit B are identical with Unit A parts except as follows:
 1. Circuit designations are in 100 series.
 2. C10, S1, DS1, F1 and XF1 are not used.
 3. R48 used on A unit for the "V" option is not used on B Unit.
 4. C115 and R147 listed here are only used on B units.

MODEL LPD-421A-FM UNIT B

C115	Cap., ceramic, 18 pf ±5%, 1000 vdc	CDH-18-001
R147	Res., ww, 2,500 ohms ±3%, 3 w	DFS-25-036

MODEL LPD-422A-FM UNIT B

C115	Cap., ceramic, 18 pf ±5%, 1000 vdc	CDH-18-001
R147	Res., ww, 5,600 ohms ±3%, 3 w	DFS-56-053

MODEL LPD-423A-FM UNIT B

C115	Cap., ceramic, 18 pf ±5%, 1000 vdc	CDH-18-001
R147	Res., ww, 8,000 ohms ±3%, 3 w	DFS-80-054

MODEL LPD-424A-FM UNIT B

R147	Res., ww, 20,000 ohms ±3%, 5 w	DFT-20-040
------	-----------------------------------	------------

PARTS FOR MODELS
LPD-421A-FM — LPD-425A-FM UNIT B (Cont.)

<u>CIRC. DESIG.</u>	<u>DESCRIPTION</u>	<u>LAMBDA NO.</u>
R147	Res., ww, 40,000 ohms ±3%, 5 w	DFT-40-047

MODEL LPD-425A-FM UNIT B

PARTS FOR "V" OPTION

"V" option only affects unit A models. On all LPD-421A-FM — LPD-425A-FM unit A models with "V" option, capacitor C10, fuse F1, and transformer T1 change, and resistor R48 is added in series with DS1. Part no. changes for C10, F1, and R48 are listed here. For transformer T1 used on these models see standard LPD-421A-FM — LPD-425A-FM model parts list for the standard transformer part no. and add suffix "G" to the part no.

ALL MODELS

C10	Cap., paper, 0.01 mf ±10%, 1000 vdc	CAL-10-021
F1	Fuse, 2A, 3AG, SLO-BLO	FFC-02-000
R48	Res., comp., 120,000 ohms ±10%, ½ w	DEB-1241

PARTS FOR OVERVOLTAGE
PROTECTOR ACCESSORY MODELS

LHOV-4, LHOV-5, LHOV-6

COMMON PARTS

C1	Cap., mylar, 0.01 mf ±20%, 80 vdc	CGL-10-008
Q1	Transistor, NPN	FBN-L102
Q2	Transistor, PNP	FBN-L114
R2	Res., film, 560 ohms ±2%, ½ w	DCR-56-002
R3	Res., film, 200 ohms ±5%, ½ w	DCR-20-010
R4	Res., thermistor, 425 ohms ±5%, 1¼ w	DKR-43-004
R5, R6	Res., comp., 1,200 ohms ±10%, ½ w	DEB-1221
R7	Res., comp., 33 ohms ±5%, ¼ w	DCB-3305
R8	Res., comp., 15,000 ohms ±10%, ½ w	DEB-1531
R9	Res., comp., 22 ohms ±10%, ½ w	DEB-2201
R10	Same as R5	
SCR1	Rectifier, silicon controlled	FBP-00-009

UNIQUE PARTS

MODEL LHOV-4

R1	Res., var., ww or cermet, 10,000 ohms ±10%, ¼ w	DNT-10-045
----	--	------------

MODEL LHOV-5

R1	Res., var., ww or cermet, 20,000 ohms ±10%, ¼ w	DNT-20-010
----	--	------------

MODEL LHOV-6

R1	Res., var., ww, 30,000 ohms ±10%, 0.6 w	DNT-30-027
----	--	------------

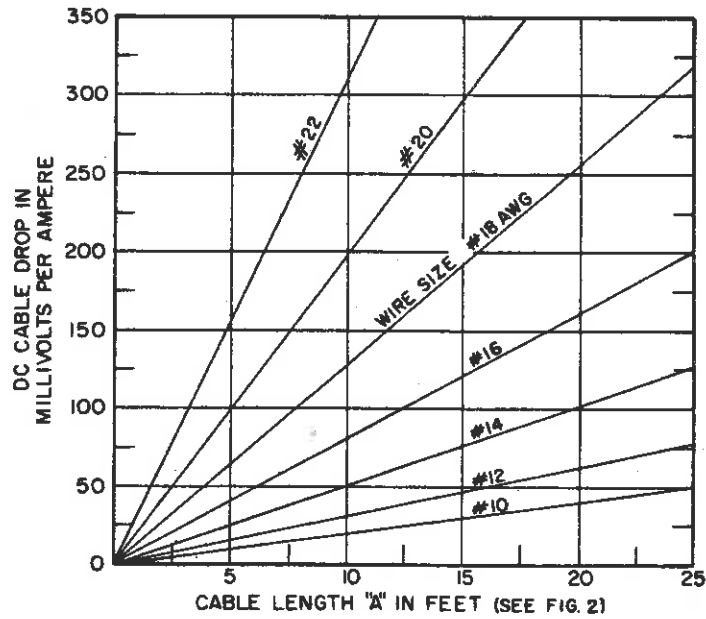

Figure 1. Cable Connection Chart

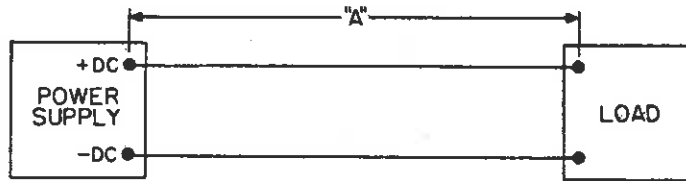
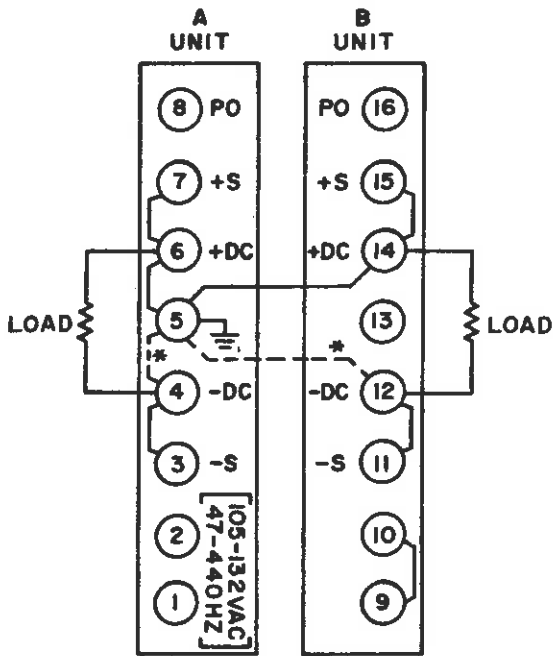
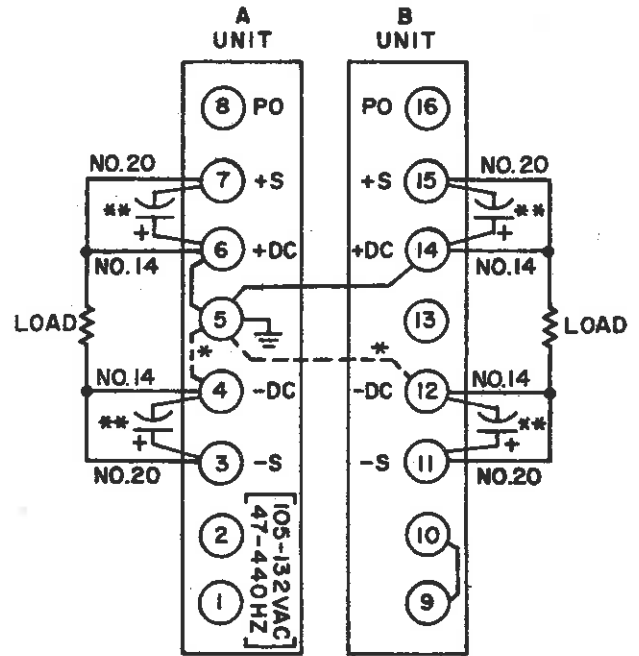

Figure 2. Cable Length "A" in Feet



* FOR NEGATIVE GROUND DISCONNECT JUMPERS FROM TERMINALS 5-6, 5-14 AND RECONNECT TO TERMINALS 5-4, 5-12.

Figure 3. Two-Wire Connection



* FOR NEGATIVE GROUND DISCONNECT JUMPERS FROM TERMINALS 5-6, 5-14 AND RECONNECT TO TERMINALS 5-4, 5-12.

** A 2.5 MF, ELECT., CAP. MAY BE REQUIRED.

Figure 4. Four-Wire Connection

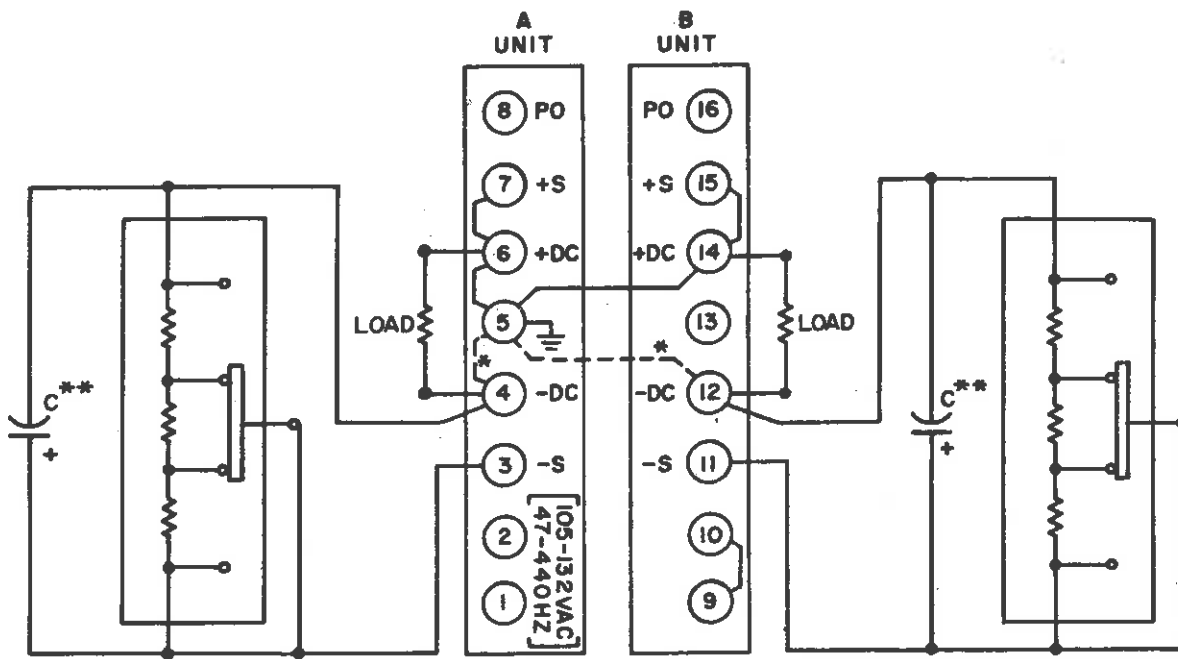

PROG. RES. = 200Ω/VOLT

NOTE: OUTPUT VOLTAGE CONTROLS MUST BE SET TO ZERO.

(A) LOCAL SENSING

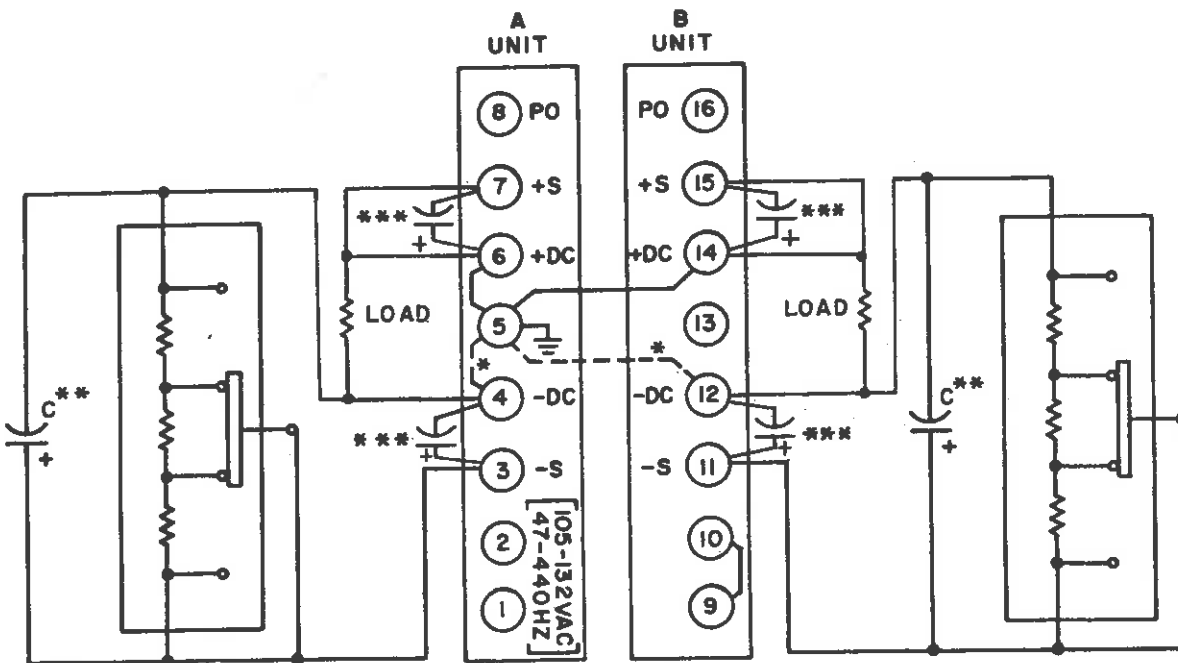

PROG. RES. = 200Ω/VOLT

NOTE: OUTPUT VOLTAGE CONTROLS MUST BE SET TO ZERO

(B) REMOTE SENSING

*FOR NEGATIVE GROUND DISCONNECT JUMPERS FROM TERMINALS 5-6, 5-14 AND RECONNECT TO TERMINALS 5-4, 5-12.

**C = 2.5 MFD, 200V FOR MODELS LPD 421A, 422A, 423A
C = 1.4 MFD, 400V FOR MODELS LPD 424A, 425A

***A 2.5 MF, ELECT. CAP. MAY BE REQUIRED.

Figure 5. Programmed Voltage, With External Resistor

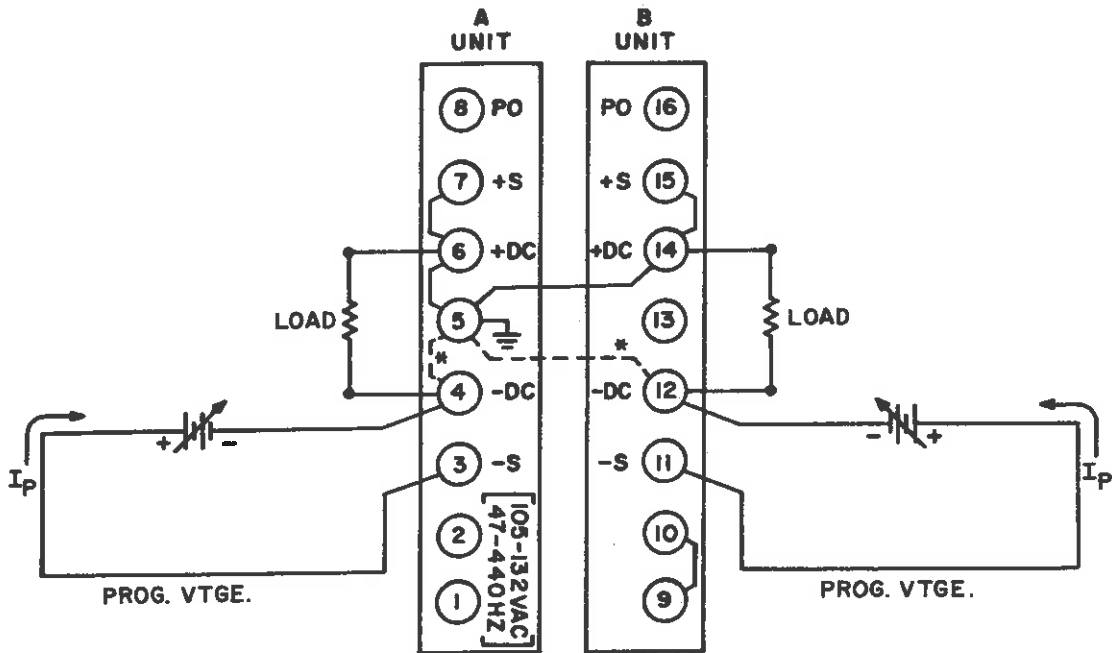

NOTE: OUTPUT VOLTAGE CONTROLS MUST BE SET TO ZERO
 (A) LOCAL SENSING

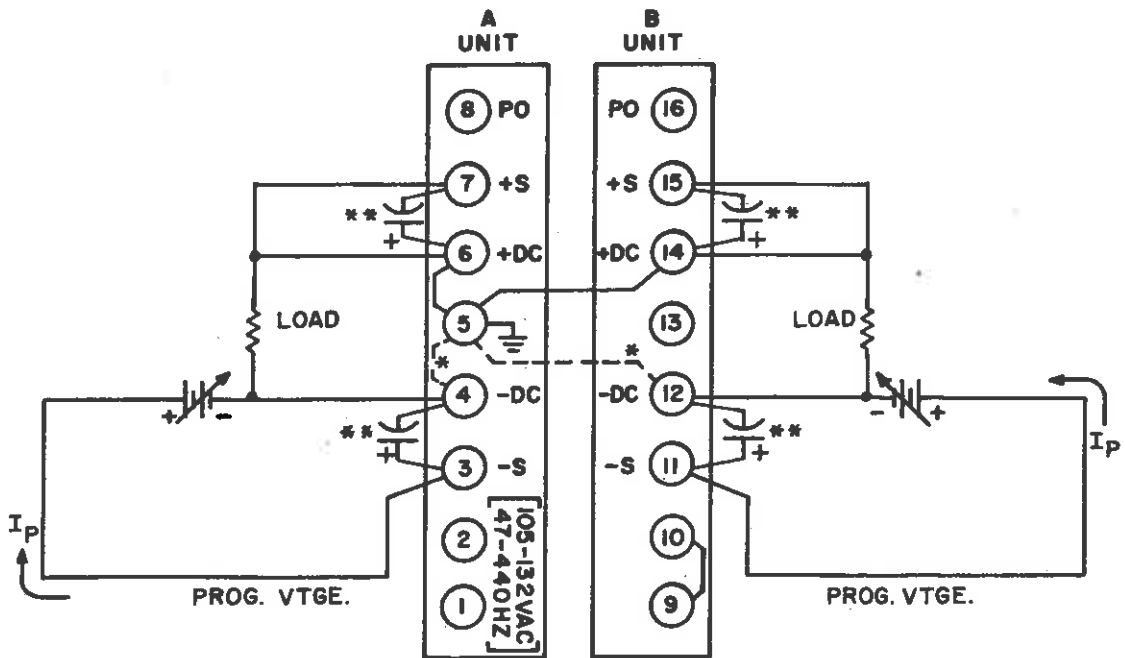

NOTE: OUTPUT VOLTAGE CONTROLS MUST BE SET TO ZERO.
 (B) REMOTE SENSING

* FOR NEGATIVE GROUND DISCONNECT JUMPERS FROM TERMINALS 5-6, 5-14 AND RECONNECT TO TERMINALS 5-4, 5-12.
 ** A 2.5 MF, ELECT., CAP. MAY BE REQUIRED.

Figure 6. Programmed Voltage, With External Programming Voltage Source

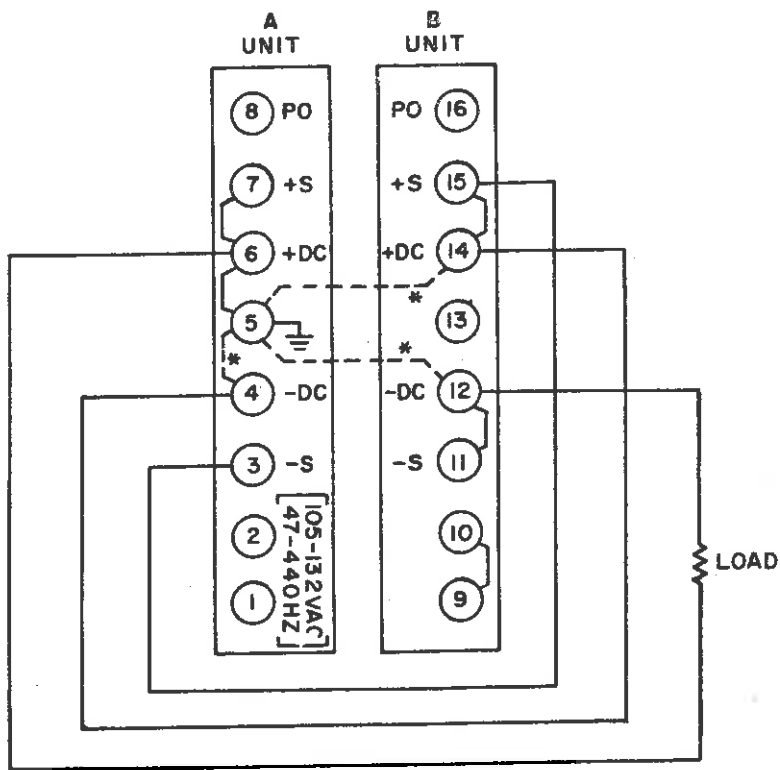

(A) LOCAL SENSING

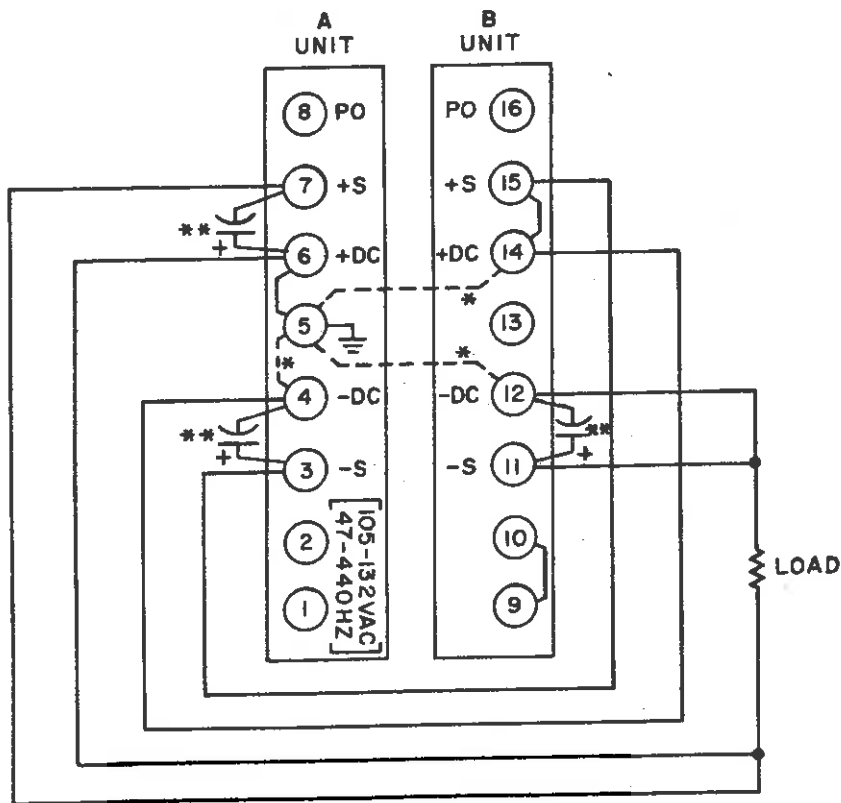

(B) REMOTE SENSING

*MAKE ONLY ONE GROUND CONNECTION FOR EACH SERIES COMBINATION; TO CHANGE GROUND AS SHOWN, REMOVE JUMPER FROM TERMINALS 5 AND 6 ON "A" UNIT AND CONNECT ANY ONE OF THE OTHER JUMPERS AS SHOWN IN DOTTED LINE.

**A 2.5 MF, ELECT., CAP. MAY BE REQUIRED.

Figure 7. Series Connection

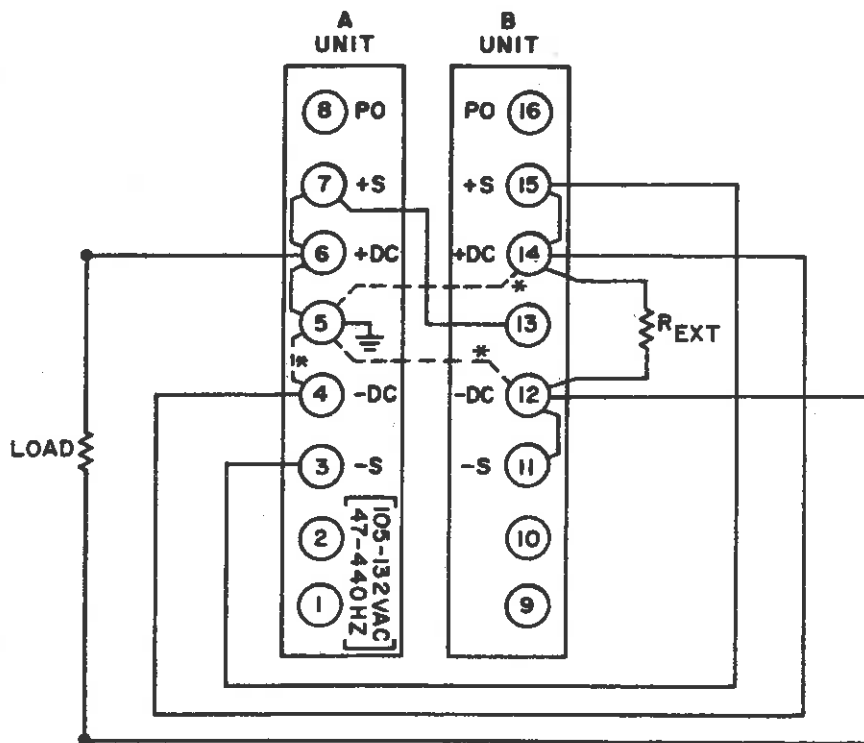

(A) LOCAL SENSING

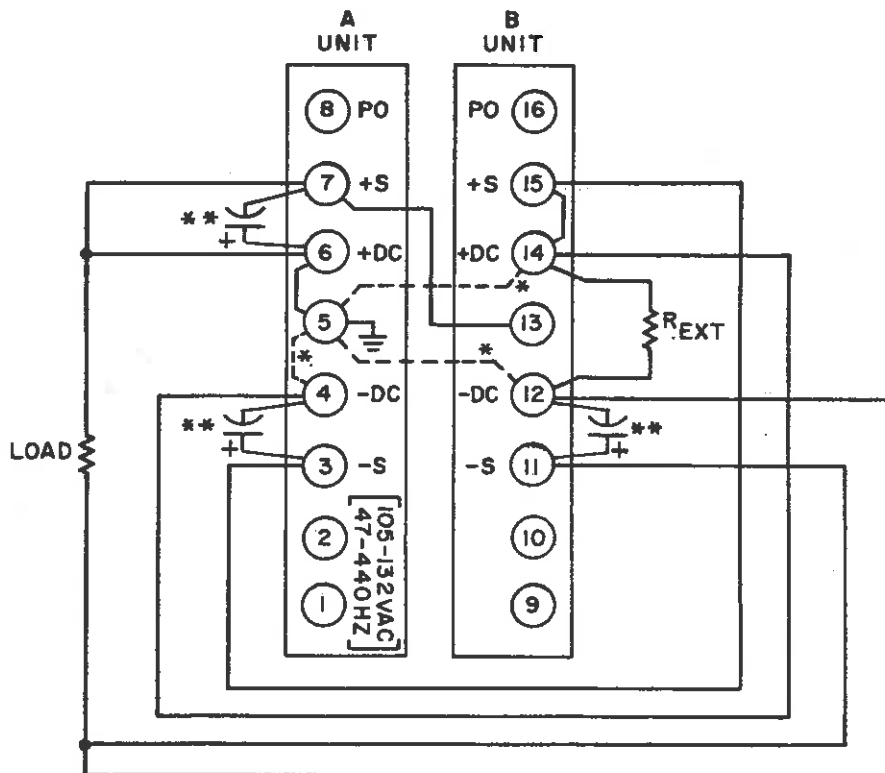

(B) REMOTE SENSING

* MAKE ONLY ONE GROUND CONNECTION FOR EACH SERIES COMBINATION; TO CHANGE GROUND AS SHOWN, REMOVE JUMPER FROM TERMINALS 5 AND 6 ON "A" UNIT AND CONNECT ANY ONE OF THE OTHER JUMPERS AS SHOWN IN DOTTED LINE.

** A 2.5 MF, ELECT., CAP. MAY BE REQUIRED.

NOTE: ONLY USE "A" UNIT OUTPUT VOLTAGE CONTROLS TO CONTROL OUTPUT OF THE SERIES COMBINATION; SET "B" UNIT VOLTAGE CONTROLS TO ZERO.

Figure 8. Auto-Series Connection

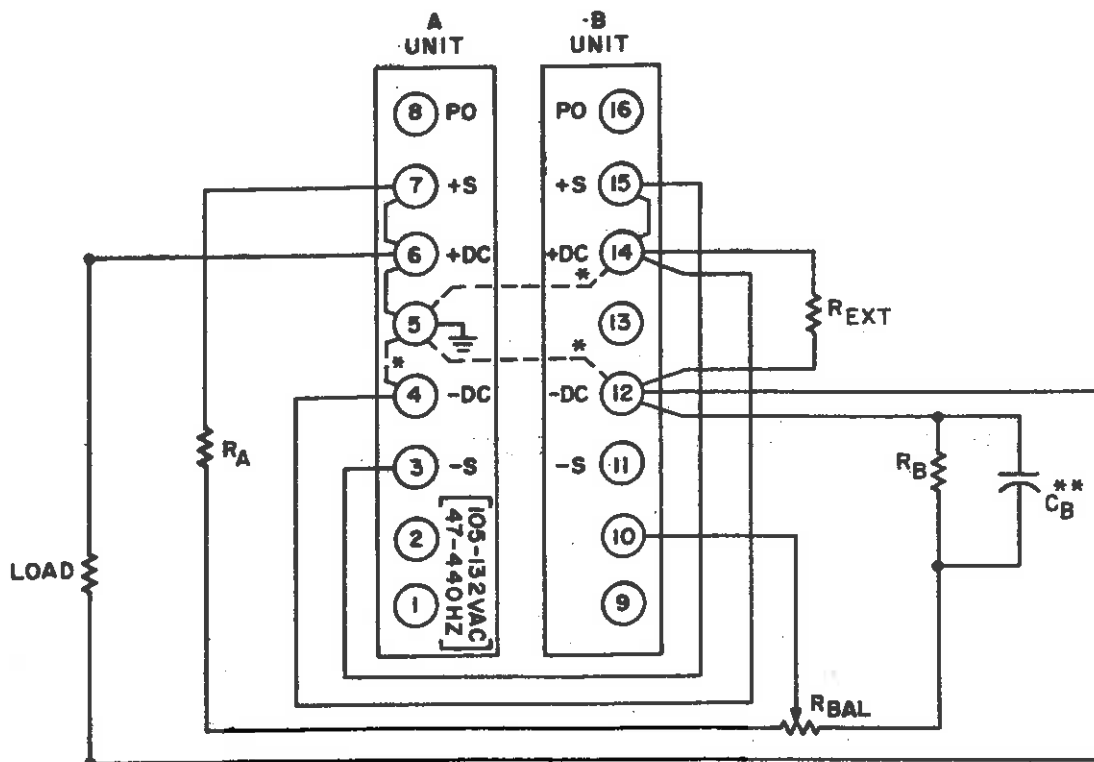

(A) LOCAL SENSING

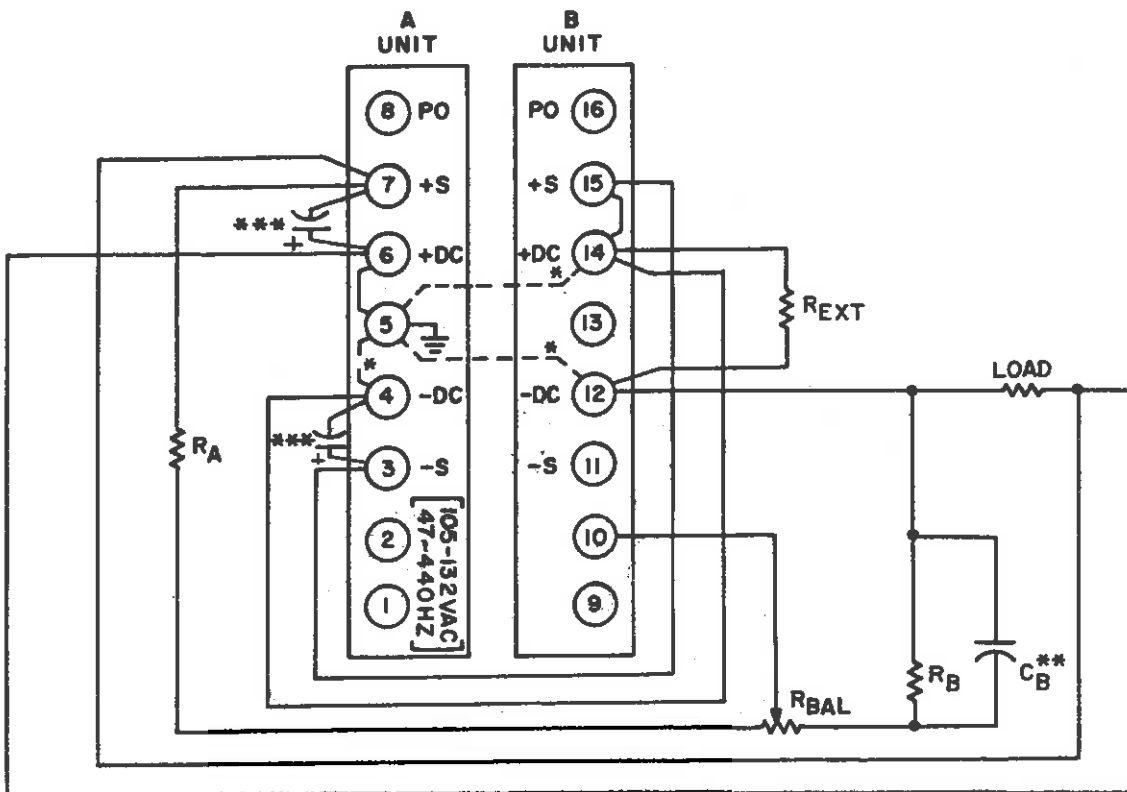

(B) REMOTE SENSING

* MAKE ONLY ONE GROUND CONNECTION FOR EACH SERIES COMBINATION; TO CHANGE GROUND AS SHOWN, REMOVE JUMPER FROM TERMINALS 5 AND 6 ON "A" UNIT AND CONNECT ANY ONE OF THE OTHER JUMPERS AS SHOWN IN DOTTED LINE.

**C = 2.5MFD, 200V FOR MODELS LPD 421A, 422A, 423A
 C = 1.4 MFD, 400V FOR MODELS LPD 424A, 425A

***A 2.5 MF, ELECT. CAP. MAY BE REQUIRED.

Figure 9. Alternate Auto-Series Connection

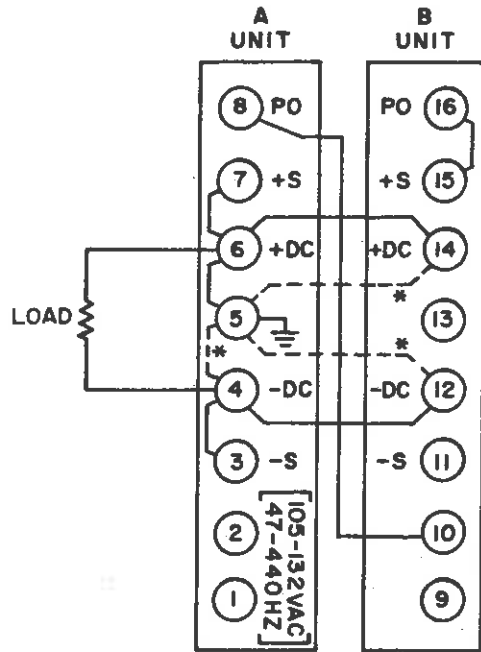

(A) LOCAL SENSING

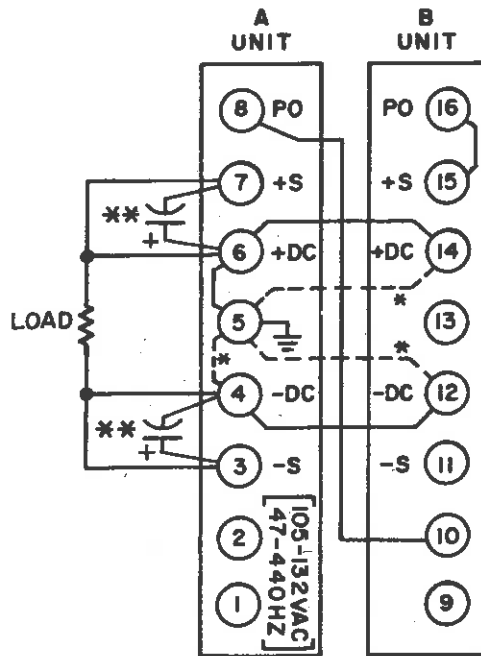

(B) REMOTE SENSING

* MAKE ONLY ONE GROUND CONNECTION FOR EACH PARALLEL COMBINATION; TO CHANGE GROUND AS SHOWN, REMOVE JUMPER FROM TERMINALS 5 AND 6 ON "A" UNIT AND CONNECT ANY ONE OF THE OTHER JUMPERS AS SHOWN IN DOTTED LINE.
 ** A 2.5 MF, ELECT., CAP. MAY BE REQUIRED.

Figure 10. Parallel Connection

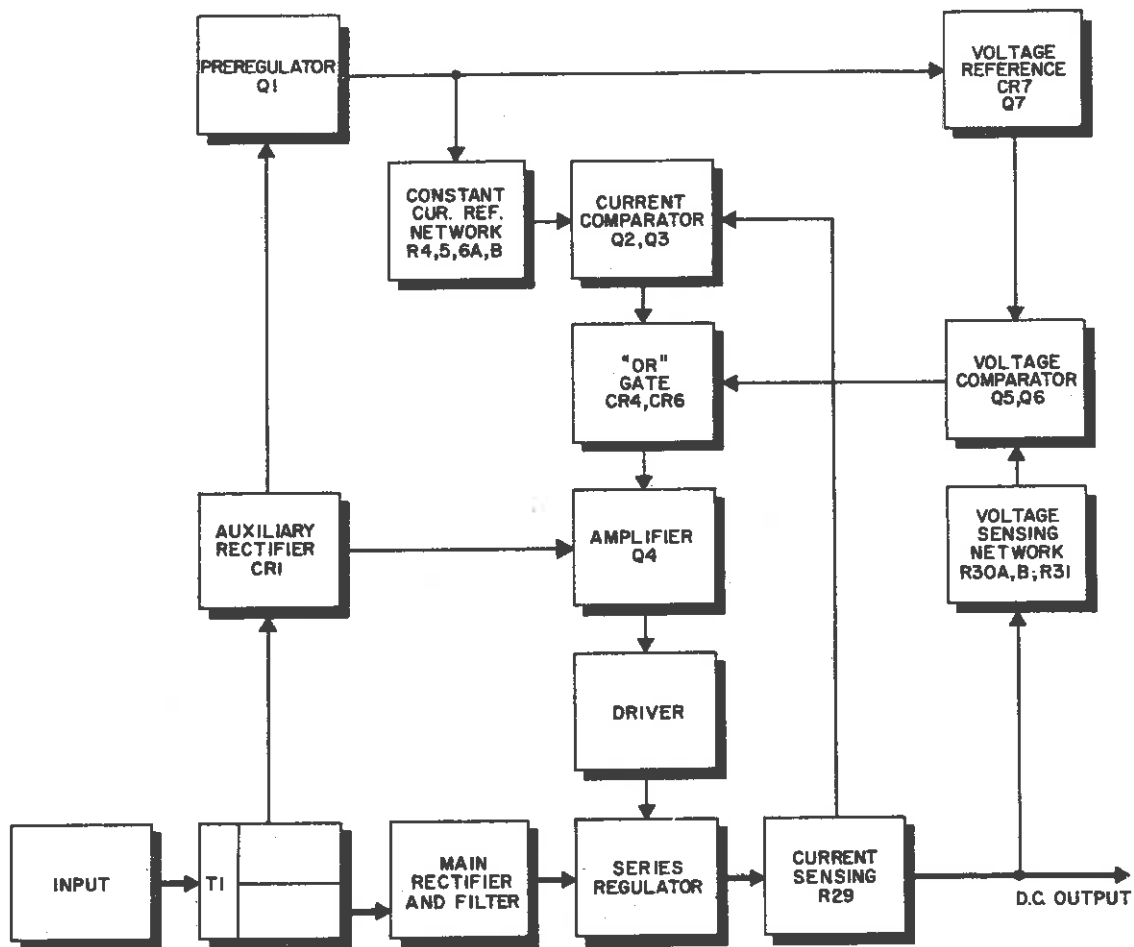

NOTE: THIS DIAGRAM APPLIES TO UNIT (B) EXCEPT INPUT BLOCK AND T1 PRIMARY ARE NOT USED AND CIRCUIT DESIGNATION NUMBERS ARE IN THE 100 SERIES.

Figure 11. Typical Block Diagram

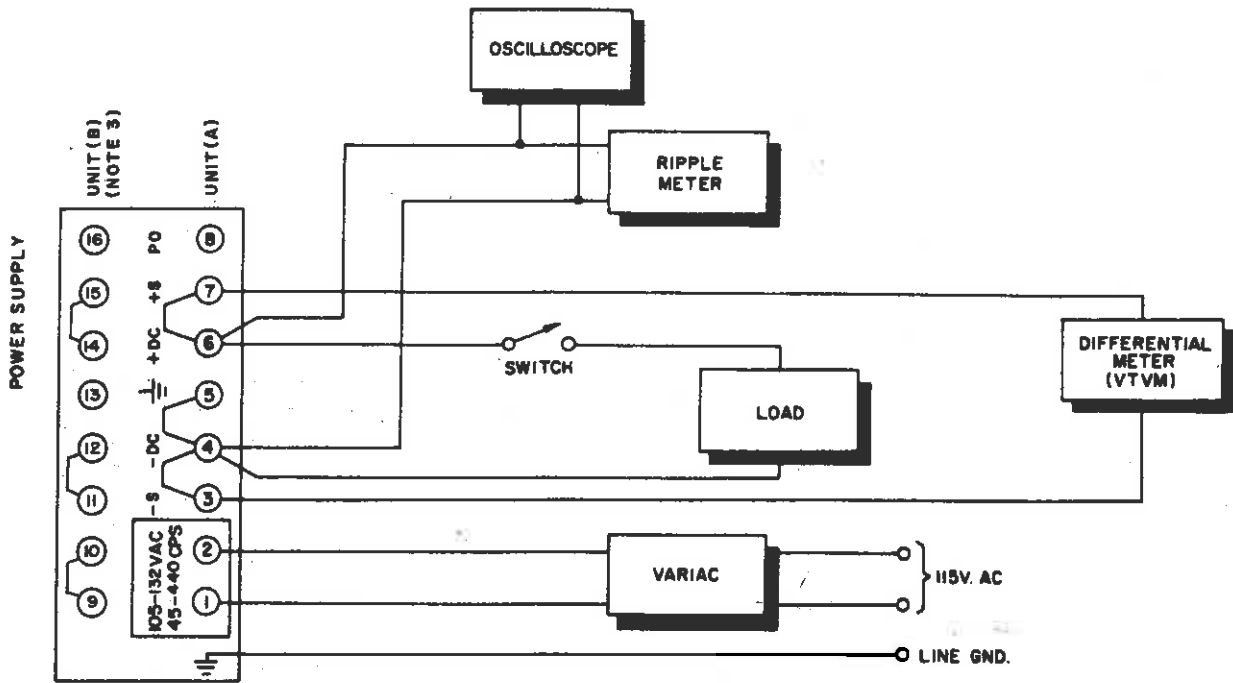

NOTES:

1. REGULATION AND RIPPLE CHECK METERS MUST NOT BE GROUNDED THROUGH THREE-WIRE LINE CORD TO GROUND.
2. PERFORM CHECKS WITH LOCAL SENSING CONNECTIONS ONLY.
3. WHEN CHECKING UNIT (B) CONNECT TO UNIT (B) TERMINALS AND ADD JUMPERS AS SHOWN; AC INPUT STILL CONNECTS TO TERMINALS 1 AND 2; TERMINAL 12 CONNECTS TO TERMINAL 5.

Figure 12. Test Connections For Constant Voltage Performance Checks

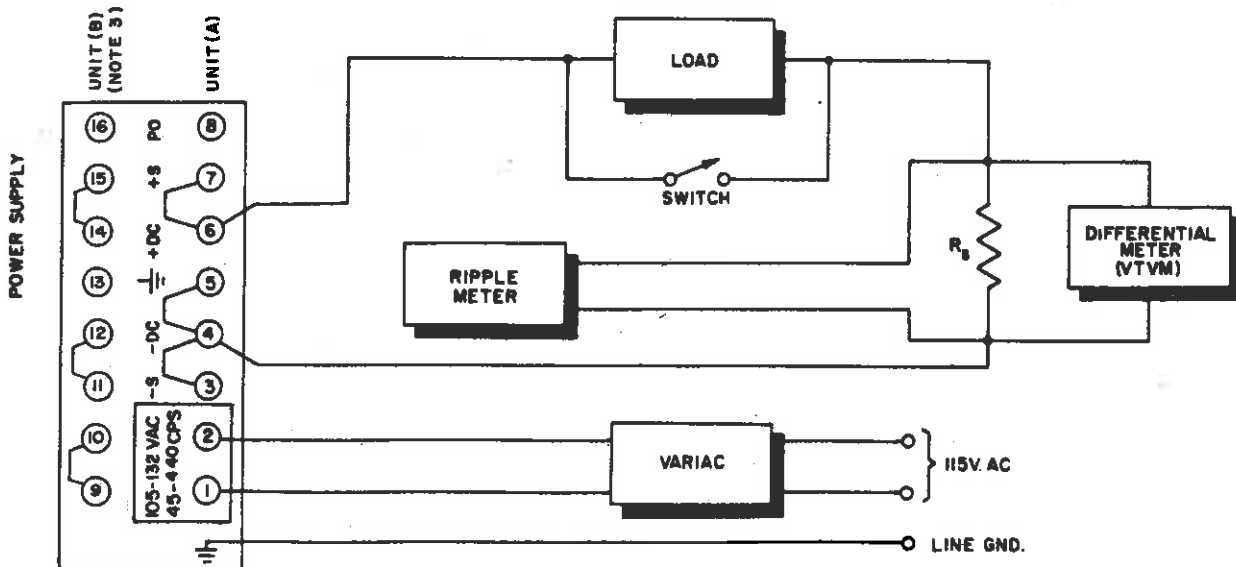

NOTES:

1. REGULATION AND RIPPLE CHECK METERS MUST NOT BE GROUNDED THROUGH THREE-WIRE LINE CORD TO GROUND.
2. PERFORM CHECKS WITH LOCAL SENSING CONNECTIONS ONLY.
3. WHEN CHECKING UNIT (B) CONNECT TO UNIT (B) TERMINALS AND ADD JUMPERS AS SHOWN; AC INPUT STILL CONNECTS TO TERMINALS 1 AND 2; TERMINAL 12 CONNECTS TO TERMINAL 5.

Figure 13. Test Connections For Constant Current Performance Checks

GENERAL DESCRIPTION

Rack adapter LRA-1 is designed for use in equipment racks where ruggedized mounting of units is required. The adapter can be used with or without chassis slides.

Rack adapter LRA-2 is designed for simple applications of rack installation where chassis slides and ruggedized mounting of equipment are not required.

Both rack adapter LRA-1 and LRA-2 can be used to install 1/4-rack or 1/2-rack power supply units into equipment racks. Each adapter can accept various combinations of 1/4 and 1/2-rack units up to four 1/4-rack units or two 1/2-rack units.

INSTALLATION OF 1/2 RACK UNITS INTO LRA-1

To install 1/2-rack power supply units, remove slide numbers 2 and 3 and/or 6 and 7, together with securing hardware and associated slide bar nut.

Using slide screws and slide bar nuts that were removed, store removed slides on the frame at the rear of the adapter where screw clearance holes are provided for securing each slide to the adapter.

SHIPMENT OF UNITS MOUNTED IN LRA-1

To protect the unit against damage from shock and vibrations when transporting adapter with installed units, eight universal tie-down mounting holes, located in the adapter base, at the rear of the rack adapter, are used to secure 1/4-rack and/or 1/2-rack units into the rack adapter. Secure each unit using two 6-32 x 5/8 screws, two lock-washers and two spacers installed from the bottom side of the rack adapter. See detail A for typical securing hardware. Eight spacers are supplied with rack adapter LRA-1.

RUGGEDIZED MOUNTING

When ruggedized mounting of units is required, follow the procedure described for SHIPMENT OF UNITS MOUNTED IN LRA-1. See detail A for typical securing hardware.

MOUNTING CHASSIS SLIDES

Mount chassis slides using the following hardware. To assure unrestricted mounting of units into the adapter designated screw lengths must not be exceeded. Insert screws into designated holes and secure slide in position using long bar nut supplied with rack adapter LRA-1.

CHASSIS TRAK NO. CTS. -116:
10-32 x 7/16 fl-hd (82°);
use A holes.

LAMBDA NO. KHT-34-003 (1 PR)
6-32 x 3/8 pan-hd;
use B, C, and D holes.

GRANT PULLEY NO. 4435:
6-32 x 5/15 fl-hd (100°);
use B and D holes.

USING BLANK PANELS

Blank front panels Model LBP-11 and LBP-21 are available for covering any 1/4-rack or 1/2-rack opening respectively. The blank panels can be used with rack adapter LRA-1 and LRA-2 whenever a 1/4-rack or 1/2-rack space in the adapter is not occupied by a unit. Secure each panel in position using four 6-32 x 3/8 pan-head screws supplied with the rack adapter.

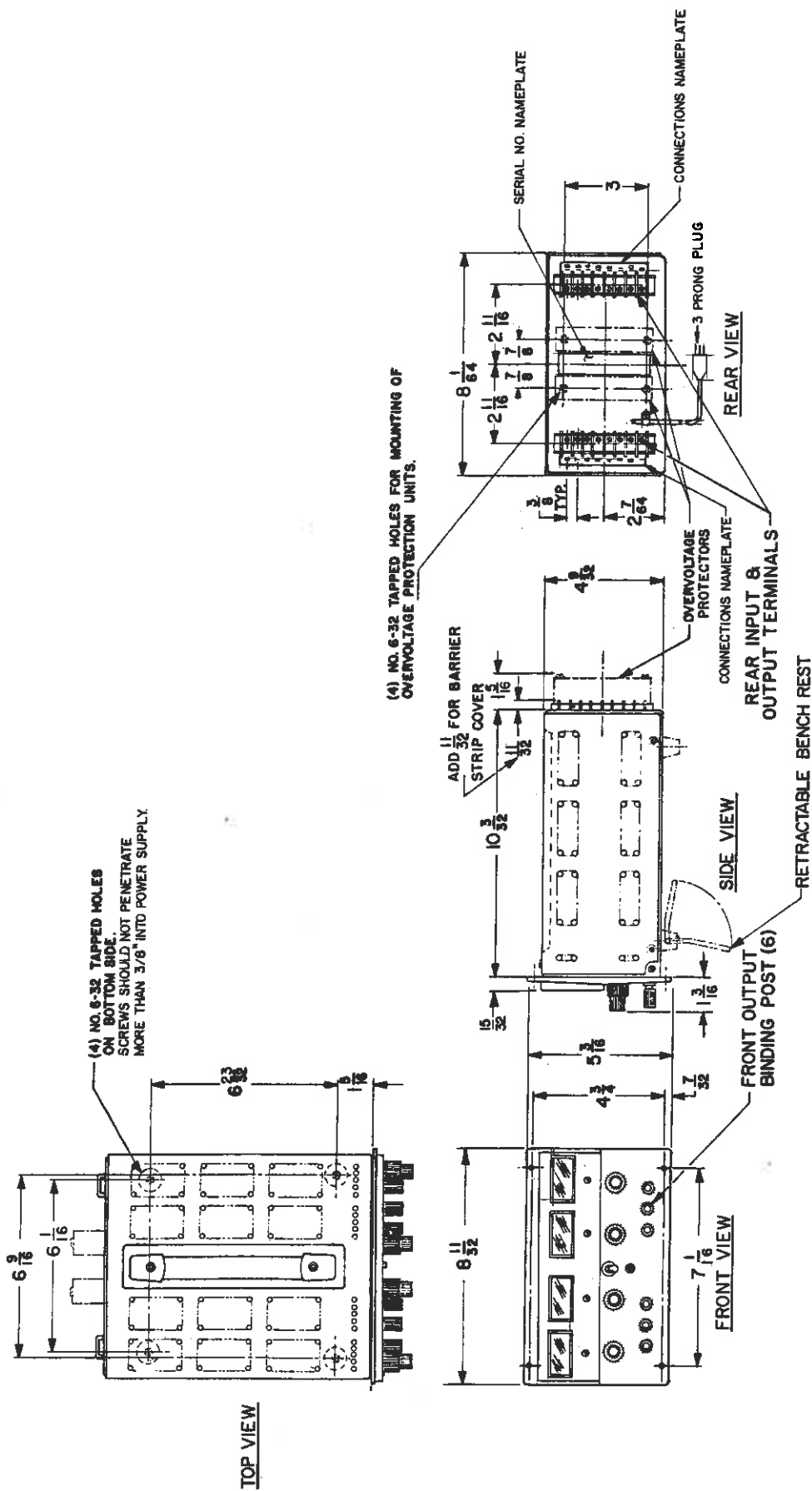

Figure 15. Outline Drawing

TABLE IV
COMPONENT DATA FOR LPD SUFFIX A
POWER SUPPLIES

MODEL	SCHEMATIC COMPONENTS*																								
	C9	C11	C14	CR12, 13, 16, 17 CR20, 21, 25, 26	CR14, 18 CR15, 19	CR23, 24 (FBL-00)	F2 (STD)	M 1	M 2	Q8, Q10 (FBL-)	Q9, Q11 (FBL-)	R18 (10%, 1/2W)	R19 (5%)	R20 (4-5%, 2W) A B	R21 (5%, 3W)	R22, 23 (5%, 1/2W)	R25 (5W)	R26 (10%, 1W)	R27 (3W)	R43 (10%, 1W)	R45 3%	R47**	R54 (10%, 1/2W)		
LPD431AFM	1500MF, 40V 80V, SURGE	400MF, 30V 40V, SURGE	0.1MF 200V	FBL-00-047	FBL-00-047	(-047)	4.0A	0-20V	0-3A	L109	38230	860	1.0 7W	8.8K 200	250	Not Used	1.0 5%	6.2K	1.0 5%	Not Used	500 5%, 7W	2.5K 3W	Not Used	Not Used	
LPD432AFM	500MF, 15V 110V, SURGE	70MF, 90V 130V, SURGE	0.018MF 200V	FBL-00-086	FBL-00-047	(-047)	3.0A	0-40V	0-1A	L108	36605	330	2.0 3W	7.5K 200	250	Not Used	2.0 5%	12K	2.0 5%	Not Used	1650 5%, 5W	5.6K 3W	Not Used	Not Used	
LPD433AFM	310MF, 110V 160V, SURGE	70MF, 90V 130V, SURGE	0.018MF 200V	FBL-00-036	FBL-00-047	(-086)	1.5A	0-50V	0-1A	L108	36902	150	2.7 2%, 3W	11.5K 200	750	Not Used	2.7 2%	33K	2.7 2%	Not Used	3.5K 3%, 5W	8.0K 3W	Not Used	Not Used	
LPD434AFM	140MF, 200V 250V, SURGE	30MF, 250V 300V, SURGE	0.01MF 600V	FBL-00-033	FBL-00-033	(-033)	1.0A	0-120V	0-0.5A	L115	36903	220	5.0 5W	24.0K	750	Not Used	Not Used	Not Used	Not Used	Not Used	Not Used	370K Used	Not Used	Not Used	Not Used
LPD435AFM	45MF, 400V 475V, SURGE	8MF, 400V 475V, SURGE	0.01MF 1000V	FBL-00-050	FBL-00-064	(-064)	0.250A	0-350V	0-150MA	L115	36983	150	16.0 3W	50.0K	750	Not Used	Not Used	Not Used	Not Used	Not Used	Not Used	Not Used	40.0K 5W	Not Used	Not Used

* Add 100 to circuit designation no. to identify applicable components used on unit (B)

** This part not used on unit (A)

NOTES

- RESISTOR VALUES ARE IN OHMS.
- RESISTOR WATTAGE 1/2 WATT; RESISTORS ABOVE 2 WATTS ARE WIREWOUND UNLESS OTHERWISE NOTED.
- RESISTOR TOLERANCES: COMPOSITION $\pm 10\%$; WIREWOUND $\pm 5\%$ FILM $\pm 5\%$; UNLESS OTHERWISE NOTED.
- CAPACITOR TOLERANCES: ELECTROLYTIC $\pm 10\%$, $+100\%$; MYLAR $\pm 10\%$; UNLESS OTHERWISE NOTED.
- SYMBOLS:
 - INDICATES CLOCKWISE ROTATION OF SHAFT
 - INDICATES CONNECTION TO CHASSIS.
 - INDICATES ADJUSTMENT OR CALIBRATION CONTROL.
 - INDICATES ACTUAL UNIT MARKING.
 - SEE INSTRUCTION MANUAL
 - LAMBDA PT.#FBL-00-030; USE IN 400Z DIODE FOR REPLACEMENT UNLESS OTHERWISE NOTED.
 - INDICATES TERMINAL ON PRINTED WIRING BOARD OR TERMINAL BOARD.
- DESIGNATIONS ARE LAMBDA PART NUMBERS
- DERATE CURRENT RATING 10% FOR 47-57 Hz, FOR 360-440 Hz CONSULT FACTORY.
- CONDITIONS FOR CIRCUIT POINT MEASUREMENTS, CV AND CC INPUT: 115 VAC, 60 Hz; INDICATED VOLTAGES ARE TYPICAL VALUES AND ARE DC UNLESS OTHERWISE NOTED. DC MEASUREMENTS TAKEN WITH 20,000 OHMS/V VOLTMETER BETWEEN +S(TERM.7) & INDICATED POINTS UNLESS NOTED.
 - CONSTANT VOLTAGE
READ NOS. NOT IN PARENTHESES
OUTPUT: MAX RATED VOLTAGE, ZERO CURRENT
 - CONSTANT CURRENT
READ NOS. IN PARENTHESES
OUTPUT: 0 VOLTS, MAX. RATED CURRENT (SHORT CIRCUIT)
- COAT BOTH SIDES OF INSULATING WAFER WITH DOW CORNING NO.340 SILICONE GREASE.
- INDICATES FRONT-PANEL MOUNTED COMPONENT.
- SEE TABLE IX FOR COMPONENT VALUE OR PART NO.
- WHEN REPLACING Q8, ALWAYS RETAIN RADIATOR AND MOUNT WITH THE REPLACEMENT PART.
- REFER TO VOLTAGES IN TABLE FOR APPROPRIATE VALUE.

MODEL	A	B	C	D	E	F	G	H	I
LPD-421AFM	30.0 (29.5)	20.0 (19.0)	0.5 (3.5)	0.0 (1.9)	1.1 (4.1)	1.6 (4.4)	20.0 (0.0)	21.1 (1.7)	1.9 (2.3)
LPD-422AFM	53.5 (50.5)	32.0 (32.0)	0.5 (4.0)	0.0 (1.7)	0.7 (4.5)	1.5 (4.8)	40.0 (0.0)	41.2 (1.7)	2.3 (2.3)
LPD-423AFM	78.0 (74.0)	47.0 (42.0)	0.5 (3.7)	0.0 (2.1)	1.0 (4.2)	1.3 (4.4)	60.0 (0.0)	61.2 (1.8)	1.9 (1.9)

- UNITS WITH "V" OPTION, F1 IS 2 AMPS, C10 IS 0.01 MF $\pm 10\%$, 1000V, PAPER, R48 IS USED WITH DSL.
- ON UNITS WITH "V" OPTION, T1 HAS TAPPED PRIMARY. "V" OPTION UNITS CAN BE WIRED FOR 187-242V INPUT (USING TAP) OR FOR 205-265V INPUT (USING ENTIRE PRIMARY).
- ON MODELS LPD-421AFM AND LPD-422AFM, R49 IS A JUMPER AND CR27 IS NOT USED.

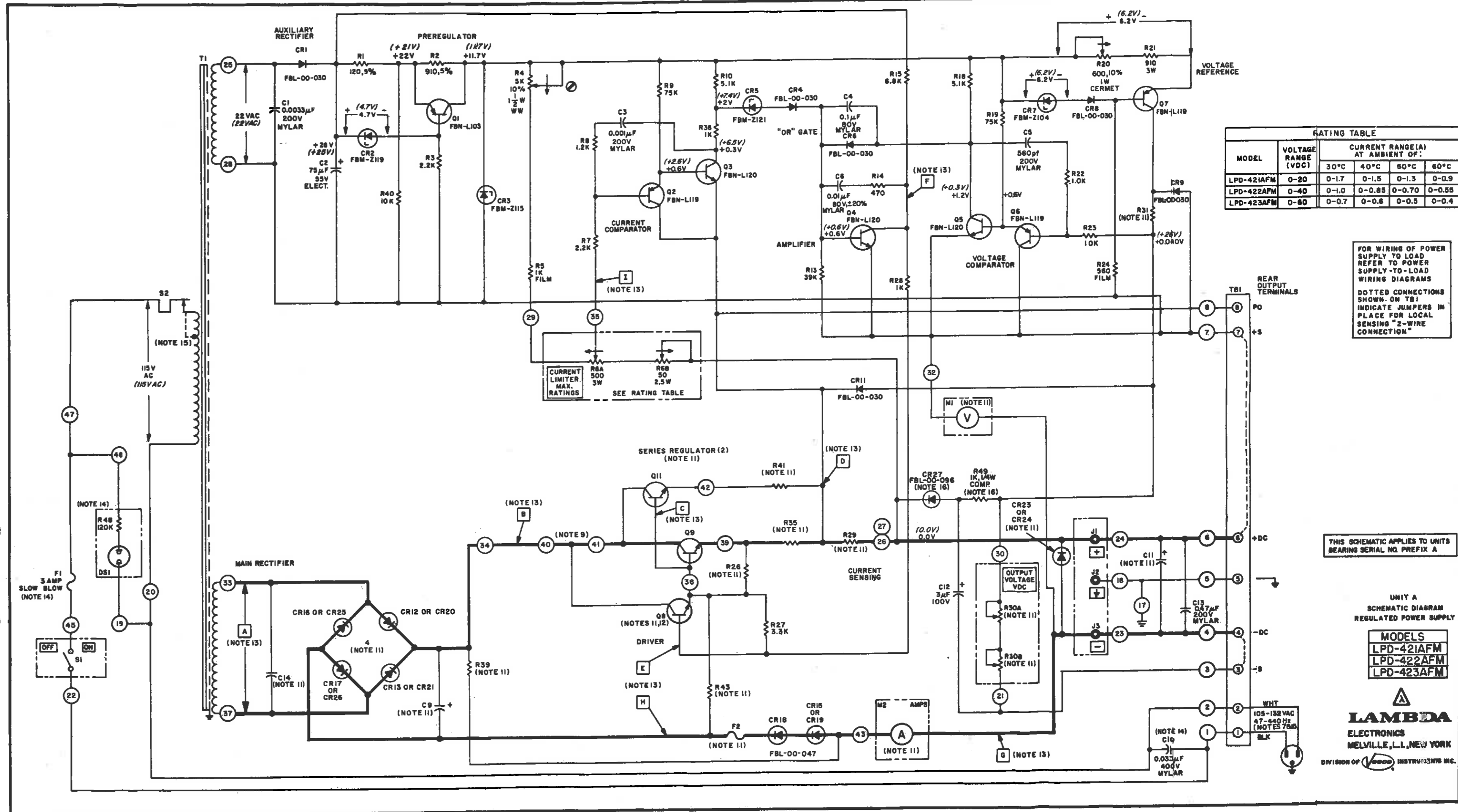

MODEL	VOLTAGE RANGE (VDC)	CURRENT RANGE(A) AT AMBIENT OF:			
		30°C	40°C	50°C	60°C
LPD-421AFM	0-20	0-1.7	0-1.5	0-1.3	0-0.9
LPD-422AFM	0-40	0-1.0	0-0.85	0-0.70	0-0.55
LPD-423AFM	0-60	0-0.7	0-0.6	0-0.5	0-0.4

FOR WIRING OF POWER SUPPLY TO LOAD REFER TO POWER SUPPLY-TO-LOAD WIRING DIAGRAMS
 DOTTED CONNECTIONS SHOWN ON T81 INDICATE JUMPERS IN PLACE FOR LOCAL SENSING "2-WIRE CONNECTION"

THIS SCHEMATIC APPLIES TO UNITS BEARING SERIAL NO. PREFIX A

UNIT A
 SCHEMATIC DIAGRAM
 REGULATED POWER SUPPLY

MODELS
 LPD-421AFM
 LPD-422AFM
 LPD-423AFM

LAMBDA
 ELECTRONICS
 MELVILLE, L.I. NEW YORK
 DIVISION OF INSTRUMENTS INC.

NOTES

- RESISTOR VALUES ARE IN OHMS.
- RESISTOR WATTAGE 1/2 WATT; RESISTORS ABOVE 2 WATTS ARE WIREWOUND UNLESS OTHERWISE NOTED.
- RESISTOR TOLERANCES: COMPOSITION ±10%; WIREWOUND ±3% FILM ±5%; UNLESS OTHERWISE NOTED.
- CAPACITOR TOLERANCES: ELECTROLYTIC -10%, +100%; MYLAR ±10%; UNLESS OTHERWISE NOTED.
- SYMBOLS:
 - ↓ INDICATES CLOCKWISE ROTATION OF SHAFT
 - ⊕ INDICATES CONNECTION TO CHASSIS.
 - ⊗ INDICATES ADJUSTMENT OR CALIBRATION CONTROL.
 - INDICATES ACTUAL UNIT MARKING.
 - * SEE INSTRUCTION MANUAL
 - λ LAMBDA PT. #FBL-00-030; USE IN 4002 DIODE FOR REPLACEMENT UNLESS OTHERWISE NOTED.
 - ⊖ INDICATES TERMINAL ON PRINTED WIRING BOARD OR TERMINAL BOARD.
- DESIGNATIONS ARE LAMBDA PART NUMBERS
- DERATE CURRENT RATING 10% FOR 47-57 Hz, FOR 360-440 Hz CONSULT FACTORY.
- CONDITIONS FOR CIRCUIT POINT MEASUREMENTS, CV AND CC INPUT: 115 VAC, 60 Hz; INDICATED VOLTAGES ARE TYPICAL VALUES AND ARE DC UNLESS OTHERWISE NOTED. DC MEASUREMENTS TAKEN WITH 20,000 OHMS/V VOLTMETER BETWEEN +S (TERM. 7) & INDICATED POINTS UNLESS NOTED.
 - CONSTANT VOLTAGE
READ NOS. NOT IN PARENTHESES
OUTPUT: MAX RATED VOLTAGE, ZERO CURRENT
 - CONSTANT CURRENT
READ NOS. IN PARENTHESES
OUTPUT: 0 VOLTS, MAX. RATED CURRENT (SHORT CIRCUIT)
- COAT BOTH SIDES OF INSULATING WAFER WITH DOW CORNING NO. 340 SILICONE GREASE.
- INDICATES FRONT-PANEL MOUNTED COMPONENT.
- SEE TABLE III FOR COMPONENT VALUE OR PART NUMBER.
- WHEN REPLACING Q8 OR Q10, ALWAYS RETAIN RADIATOR AND MOUNT WITH THE REPLACEMENT PART.
- REFER TO VOLTAGES IN TABLE FOR APPROPRIATE VALUE.

MODEL	A	B	C	D	E	F	G	H	I	J	K	L
	VAC	+VDC	+VDC	+VDC	+VDC	+VDC	-VDC	-VDC	+VDC	+VDC	+VDC	+VDC
LPD-424AFM	136 (130)	68.0 (167)	0.5 (2.5)	0.0 (2.0)	1.1 (3.1)	1.3 (3.4)	120 (10.0)	120.7 (11.0)	2.0 (2.0)	31 (80.0)	32 (81.0)	32 (81.0)
LPD-425AFM	250 (243)	96.0 (520)	0.7 (2.8)	0.0 (2.2)	1.2 (3.4)	1.5 (3.7)	250 (10.0)	250.6 (11.3)	2.2 (2.2)	42 (152)	43 (153)	43 (153)

- FOR UNITS WITH "V" OPTION, F1 IS 2AMPS, C10 IS 0.01 MF ±10%, 1000V, PAPER AND R48 IS USED WITH DS1.
- ON UNITS WITH "V" OPTION, T1 HAS TAPPED PRIMARY. "V" OPTION UNITS CAN BE WIRED FOR 187-242V INPUT (USING TAP) OR FOR 205-265V INPUT (USING ENTIRE PRIMARY).

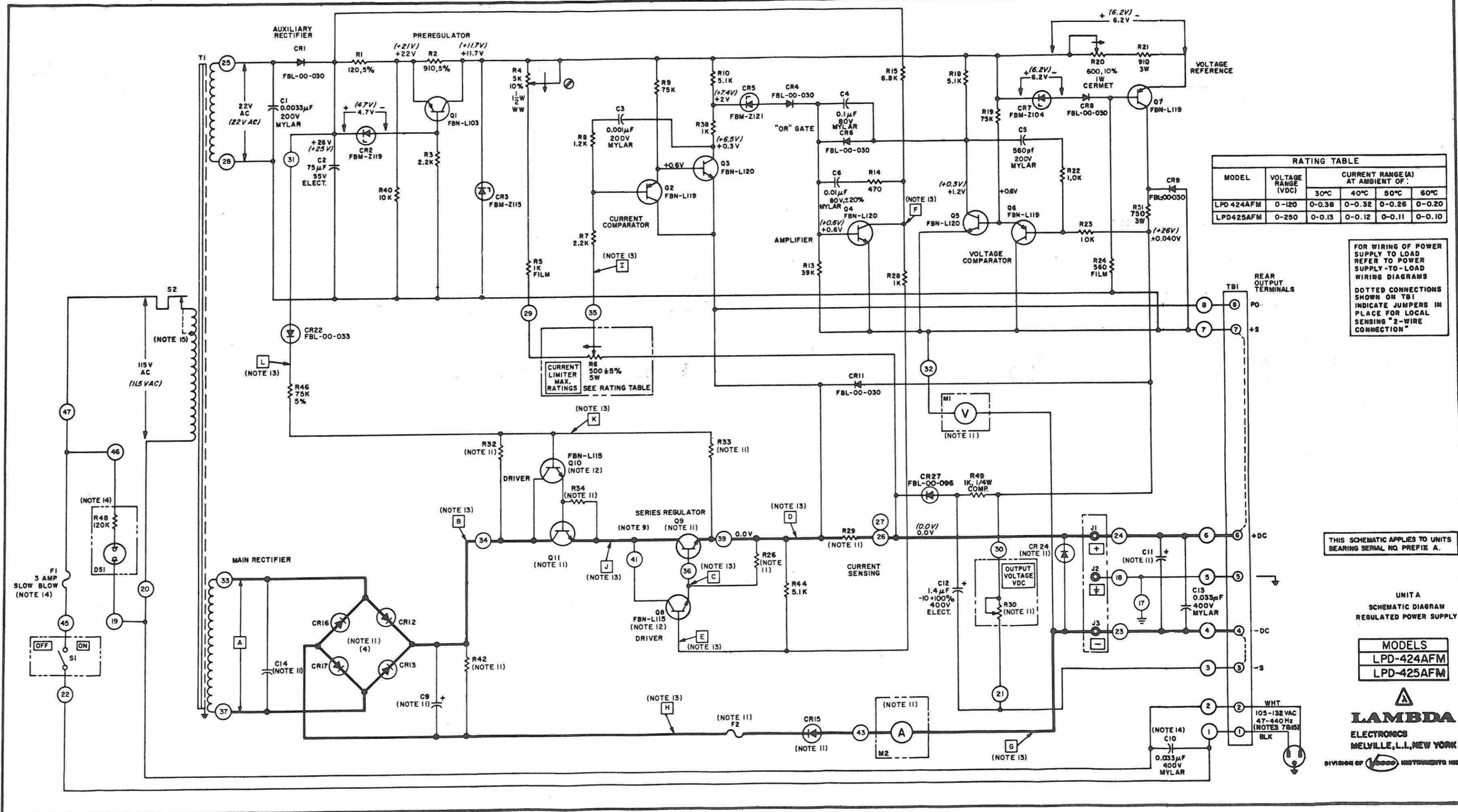

MODEL	VOLTAGE RANGE (VDC)	CURRENT RANGE (A) AT AMBIENT OF:			
		30°C	40°C	50°C	60°C
LPD424AFM	0-120	0-0.36	0-0.32	0-0.26	0-0.20
LPD425AFM	0-250	0-0.13	0-0.12	0-0.11	0-0.10

FOR WIRING OF POWER SUPPLY TO LOAD REFER TO LOAD SUPPLY-TO-LOAD WIRING DIAGRAMS
 DOTTED CONNECTIONS SHOWN ON T81 INDICATE JUMPERS IN PLACE FOR LOCAL SENSING "2-WIRE CONNECTION"

THIS SCHEMATIC APPLIES TO UNITS BEARING SERIAL NO. PREFIX A.

UNIT A
 SCHEMATIC DIAGRAM
 REGULATED POWER SUPPLY

MODELS
 LPD-424AFM
 LPD-425AFM

LAMBDA
 ELECTRONICS
 MELVILLE, L.I., NEW YORK
 DIVISION OF INSTRUMENTS INC.

- NOTES**
- RESISTOR VALUES ARE IN OHMS.
 - RESISTOR WATTAGE 1/2 WATT; RESISTORS ABOVE 2 WATTS ARE WIREWOUND UNLESS OTHERWISE NOTED.
 - RESISTOR TOLERANCES: COMPOSITION ±10%; WIREWOUND ±3% FILM ±5%; UNLESS OTHERWISE NOTED.
 - CAPACITOR TOLERANCES: ELECTROLYTIC -10%, +100%; MYLAR ±10%; UNLESS OTHERWISE NOTED.
 - SYMBOLS:
 - ↓ INDICATES CLOCKWISE ROTATION OF SHAFT
 - ⊥ INDICATES CONNECTION TO CHASSIS.
 - ⊕ INDICATES ADJUSTMENT OR CALIBRATION CONTROL.
 - INDICATES ACTUAL UNIT MARKING.
 - * SEE INSTRUCTION MANUAL
 - λ LAMBDA PT.#FBL-00-030; USE IN 4002 DIODE FOR REPLACEMENT UNLESS OTHERWISE NOTED.
 - ⊖ INDICATES TERMINAL ON PRINTED WIRING BOARD OR TERMINAL BOARD.
 - DESIGNATIONS ARE LAMBDA PART NUMBERS
 - DERATE CURRENT RATING 10% FOR 47-57 Hz, FOR 300-440 Hz CONSULT FACTORY.
 - CONDITIONS FOR CIRCUIT POINT MEASUREMENTS, CV AND CC INPUT: 115 VAC, 60 Hz; INDICATED VOLTAGES ARE TYPICAL VALUES AND ARE DC UNLESS OTHERWISE NOTED. DC MEASUREMENTS TAKEN WITH 20,000 OHMS/V VOLTMETER BETWEEN +S (TERM. 7) & INDICATED POINTS UNLESS NOTED.
 - A. CONSTANT VOLTAGE
READ NOS. NOT IN PARENTHESES
OUTPUT: MAX RATED VOLTAGE, ZERO CURRENT
 - B. CONSTANT CURRENT
READ NOS. IN PARENTHESES
OUTPUT: 0 VOLTS, MAX. RATED CURRENT (SHORT CIRCUIT)
 - COAT BOTH SIDES OF INSULATING WAFER WITH DOW CORNING NO. 340 SILICONE GREASE.
 - INDICATES FRONT-PANEL MOUNTED COMPONENT.
 - SEE TABLE III FOR COMPONENT VALUE OR PART NUMBER.
 - WHEN REPLACING Q108 OR Q110, ALWAYS RETAIN RADIATOR AND MOUNT WITH THE REPLACEMENT PART.
 - REFER TO VOLTAGES IN TABLE FOR APPROPRIATE VALUE.

VOLTAGE-POINT VALUE TABLE

MODEL	A	B	C	D	E	F	G	H	I	J	K	L
LPD-424AFM	136 (130)	68.0 (167)	0.5 (2.5)	0.0 (2.0)	1.1 (3.1)	1.3 (3.4)	120 (100)	120.7 (110)	2.0 (2.0)	31 (80.0)	32 (81.0)	32 (81.0)
LPD-425AFM	250 (243)	96.0 (120)	0.7 (2.8)	0.0 (2.2)	1.2 (3.4)	1.5 (3.7)	250 (100)	250.6 (113)	2.2 (2.2)	42 (152)	43 (153)	43 (153)

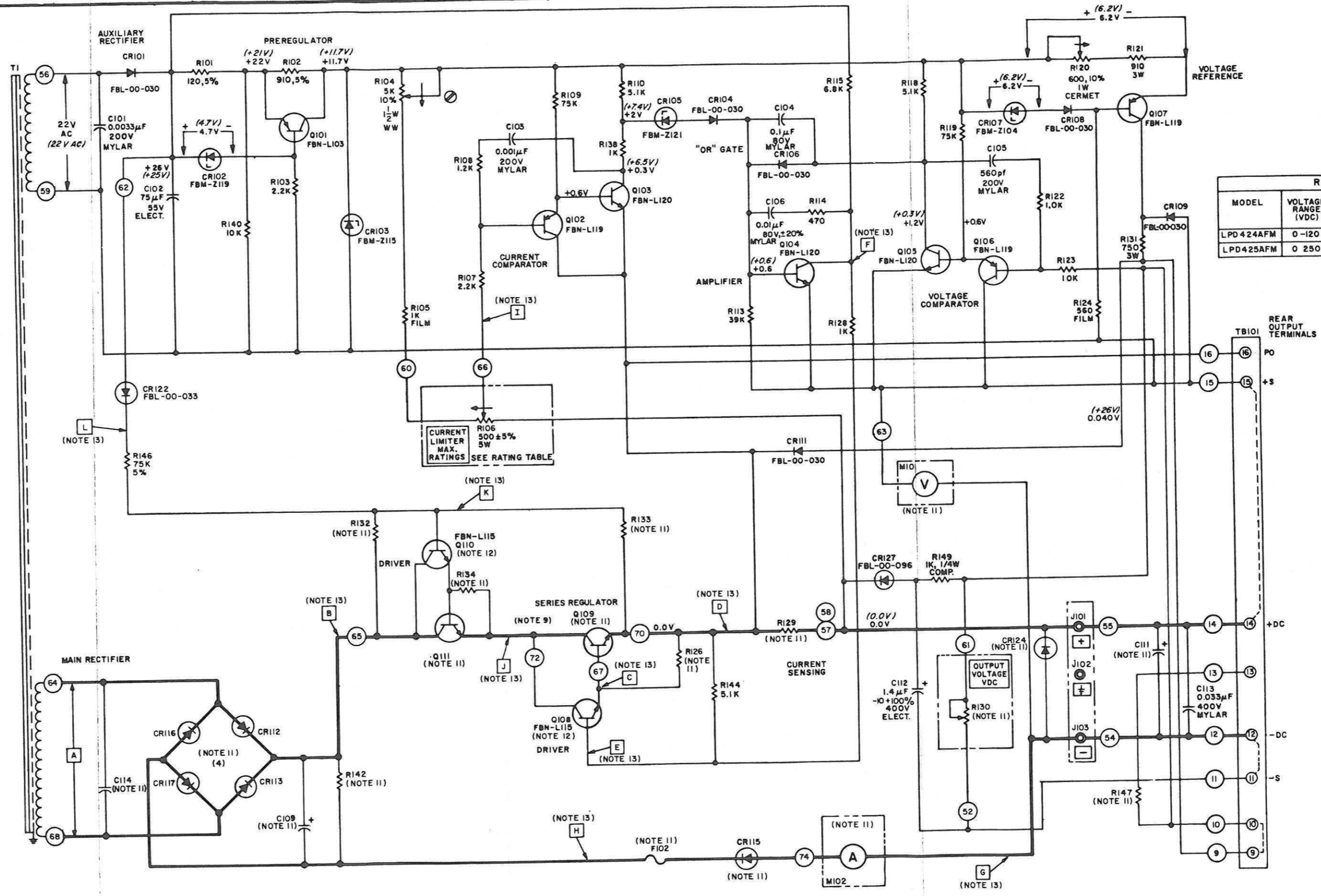

RATING TABLE

MODEL	VOLTAGE RANGE (VDC)	CURRENT RANGE (A) AT AMBIENT OF:			
		30°C	40°C	50°C	60°C
LPD 424AFM	0-120	0-0.38	0-0.32	0-0.26	0-0.20
LPD 425AFM	0-250	0-0.13	0-0.12	0-0.11	0-0.10

FOR WIRING OF POWER SUPPLY TO LOAD REFER TO POWER SUPPLY-TO-LOAD WIRING DIAGRAMS
 DOTTED CONNECTIONS SHOWN ON T81 INDICATE JUMPERS IN PLACE FOR LOCAL SENSING "2-WIRE CONNECTION"

THIS SCHEMATIC APPLIES TO UNITS BEARING SERIAL NO. PREFIX A.

UNIT B
 SCHEMATIC DIAGRAM
 REGULATED POWER SUPPLY

MODELS
 LPD-424AFM
 LPD-425AFM

LAMBDA
 ELECTRONICS
 MELVILLE, L.I., NEW YORK
 DIVISION OF **VEECO** INSTRUMENTS INC.