

**INSTRUCTION MANUAL
FOR
REGULATED POWER SUPPLIES**

LLS-6000 SERIES

This manual provides instructions intended for the operation of Lambda power supplies, and is not to be reproduced without the written consent of Lambda Electronics. All information contained herein applies to all LLS-6000 series models unless otherwise specified.

LAMBDA ELECTRONICS

MAIN PLANT TELEPHONE: (516) 694-4200

MELVILLE, N.Y.

IM-LLS-6000

9/90

TABLE OF CONTENTS

| Section | Page |
|---|------|
| SPECIFICATIONS AND FEATURES..... | 1 |
| OPERATING INSTRUCTIONS..... | 7 |
| Controls, Fuses and Indicators..... | 7 |
| Connections..... | 8 |
| Basic Modes of Operation and Operating Procedures..... | 9 |
| Operation as a Constant Voltage Source..... | 9 |
| Operation as a Constant Current Source..... | 11 |
| Other Modes of Operation..... | 12 |
| Adjustment of Front Panel Overvoltage Control..... | 13 |
| Operation After Protective Device Shutdown..... | 14 |
| MAINTENANCE..... | 15 |
| General..... | 15 |
| Periodic Maintenance..... | 15 |
| Trouble Analysis..... | 15 |
| Checking Transistors and Capacitors..... | 15 |
| Printed Circuit Board Maintenance Techniques..... | 16 |
| Trouble Chart..... | 16 |
| Performance Checks..... | 21 |
| Power Supply Calibration Procedure..... | 22 |
| Calibration of Output-Voltage-Range Controls R202 and R223..... | 22 |
| Calibration of Output-Current-Range Controls R204 and R264..... | 22 |
| Calibration of V_o (meas) adjust R210..... | 23 |
| Calibration of I_o (min) measure R632 and I_o (max) measure R634..... | 23 |
| SERVICE..... | 23 |
| PARTS ORDERING..... | 24 |

SPECIFICATIONS AND FEATURES

(Specifications Apply for all models)

DC OUTPUT - Voltage and Current regulated for line and load.

TABLE I

VOLTAGE AND CURRENT RATINGS

| MODEL | VOLTAGE (volts) | MAXIMUM CURRENT (AMPS) AT AMBIENT TEMPERATURE | | | |
|----------|--------------------|--|------|-------|-------|
| | | 40°C | 50°C | 60°C | 71°C |
| LLS-6008 | 0 to 8 | 20A | 20A | 16.5A | 13.5A |
| LLS-6018 | 0 to 18 | 9A | 9A | 8.2A | 6.6A |
| LLS-6040 | 0 to 40 | 4A | 4A | 3.8A | 3.1A |
| LLS-6060 | 0 to 60 | 2.8A | 2.8A | 2.6A | 2.1A |
| LLS-6120 | 0 to 120 | 1.4A | 1.4A | 1.3A | 1A |
| LLS-6300 | 0 to 300 | .56A | .56A | .52A | .40A |

Current range must be chosen to suit appropriate maximum ambient temperature.
Current ratings apply for entire voltage range.

REGULATED VOLTAGE OUTPUT

- Regulation (line) 0.05% of $V_o(\max)$ for input changes from 85 - 132 or 170 - 265 volts AC or 240 - 350 volts DC.
- Regulation (load) 0.05% of $V_o(\max)$ from 0 to full load.
- Ripple and Noise 5 millivolts rms, 35 millivolts peak-to-peak on models LLS-6008 and LLS-6018.
(20 MHZ measurement bandwidth) 10 millivolts rms, 75 millivolts peak-to-peak on models LLS-6040 and LLS-6060.
20 millivolts rms, 150 millivolts peak-to-peak on models LLS-6120 and LLS-6300.
- Overshoot No overshoot at turn on, turn off or power failure.

REGULATED VOLTAGE OUTPUT ((Cont'd)

| | |
|--|--|
| Negative Offset Voltage | Power supplies are shipped from the factory with minimum output calibrated to 0 +/- 10 millivolts. Internal calibration is available to achieve up to -0.1V negative offset, if desired. |
| Temperature Coefficient | 0.03% per degree C. |
| Stability (drift) | 0.1% per 8 hour period after 30 minute warm up. |
| Remote Programming: External Resistor | Adjustable from 1000 ohms per volt to 200 ohms per volt (Rp terminal to -V). LLS-6300 available only as 1000 ohms per volt. |
| Programming Voltage | One-to-one voltage change (RP terminal to -V). Zero to 5 Volt signal from RVP terminal (TB202-2) to Common terminal (TB202-6) programs output from 0 to Vo(max). (Remote programming signal must be floated from both +V and -V.) |
| Remote Sensing | Provision is made for remote sensing to eliminate effect of power output lead resistance on DC regulation. |

REGULATED CURRENT OUTPUT (AUTOMATIC CROSSOVER):

| | |
|--------------------------|--|
| Regulation (line) | 0.3% Io (max) for input changes from 85 - 132 volts AC or 170 - 265 volts AC. (240-350V DC) |
| Regulation (load) | 0.3% Io(max) for output voltage changes from Vo(max) to short circuit |
| Current range | Specifications apply for 5% to full load current |
| Voltage range | As shown in Table 1. |
| Ripple | 1% Io(max)-rms. |
| Remote programming | Zero to 5V signal from RCP terminal (TB202-4) to Common terminal (TB202-6) programs output from 0 to Io(max). (Remote programming signal must be floated from both +V and -V.) |

AC INPUT

| | |
|------------------------------|---|
| Line voltage | 85 - 132 volts AC (47-440Hz) or 170 - 265 volts AC (47-440Hz) via rear panel selector switch. Where applicable, regulatory agency approval applies only for input voltages up to 250 volts AC and for input frequencies in the range of 47-63 Hz. Leakage current in the ground connection may exceed the limits allowed by the agencies at frequencies above this range. |
| Input power | 245 watts max. |
| Input RMS current | 4.0 Amperes max. |
| Efficiency | 65% minimum |
| Input surge protection | Meets IEEE 587-1980 for branch circuits and outlets (class A). |
| Inrush limiting | Power-up inrush current will not exceed 40 Amps peak. |
| EMI | Conducted spectrum conforms with requirements of FCC Docket 20780 Class A (85-132 VAC input) and VDE 0871 Class A (170 - 250 VAC input). |

DC INPUT - LLS-6000 models will function with a DC input of 240 to 350 volts (Non-polarized). DC input current is 1.1 amps max. (Line select switch must be in 220 position).

PARALLEL OPERATION - LLS-6000 units of the same rated output voltage can be paralleled in a master/slave arrangement.

SERIES OPERATION - LLS-6000 units of the same rated output voltage can be connected in series with auto-tracking so that both units will track to a common reference.

OVERLOAD PROTECTION

| | |
|---------------|--|
| Thermal | Internal airflow sensing circuit shuts down unit's operation if air inlet blockage or fan rotor lockup occurs. When a thermal shutdown occurs, the main oscillator's operation will be terminated and all internal bias supplies, and the front panel meters, will shut down. In addition, a front panel fault indicator light will turn on. AC power must be removed for approximately 10 seconds to reset the shut-down circuit. |
|---------------|--|

OVERLOAD PROTECTION (Cont'd)

Electrical

| | |
|--------------|---|
| Input | 10A/250V Normal Blo fuse F101 protects AC input circuitry. 3A miniature fuse F103 and 0.25A miniature F201 protect printed circuit board from damage in the case of internal component failures. |
| Output | Automatic constant-current-limiting circuit limits the output current to a customer adjustable value (0% to 102% full load), thereby providing protection for the load as well as the power supply. In addition, there is an internal inverter peak-current-limit circuit which protects the power supply during load transients. |

Note: On LLS-6300 models, repeated abrupt application of 300V to short-circuit transients can cause over-dissipation and eventual damage to internal circuitry. Repetition rate of transients to short circuit should be limited to less than 2 per minute for long-term operation. (Note that once in short-circuit, continuous operation is per normal rating limits)

OVERVOLTAGE PROTECTION

All LLS-6000 models include a built-in adjustable overvoltage protection circuit which prevents damage to the load caused by excessive power supply output voltage. Exceeding the overvoltage set point will shut down the unit's operation and cause the front panel fault indicator to light up. AC power must be removed from the unit for approximately 10 seconds to reset the OV shutdown circuit.

| | |
|---------------------------------------|--------------------------------|
| Overvoltage Adjustability Range | Model LLS-6008: 4 to 11 VDC |
| | Model LLS-6018: 4 to 24 VDC. |
| | Model LLS-6040: 8 to 50 VDC. |
| | Model LLS-6060: 8 to 70 VDC. |
| | Model LLS-6120: 20 to 130 VDC. |
| | Model LLS-6300: 55 to 330 VDC. |

REMOTE TURN-ON / TURN-OFF - A TTL low signal (0 to 0.5V), or a short, between Remote on/off terminal (TB202-5) and common terminal (TB202-6) enables the output. A TTL high (2.8 to 5V), or open circuit, between the Remote on/off terminal and the common terminal will bring the output voltage to zero.

COOLING - Forced-air cooling using ball-bearing, long-life fan (no lubrication needed). Fan draws air in through front portion of chassis and exhausts air through perforations at rear of unit. Leave adequate clearance at all air intake and exhaust openings.

OPERATING AMBIENT TEMPERATURE RANGE AND DUTY CYCLE - Continuous duty from 0 to 71°C ambient with corresponding load current ratings for all modes of operation, and appropriate derating.

STORAGE TEMPERATURE (Non-operating) - -55°C to +85°C

INPUT/OUTPUT CONNECTIONS

- AC input and line safety ground IEC power line connector (recessed 3-pin male).
- DC output Heavy-duty, printed-circuit-board-mounted terminal block at rear of chassis (TB201).
- Output ground Tapped hole in chassis at rear of unit.
- DC sensing, Remote voltage programming, Remote current programming, Remote on/off, Remote resistance programming, Parallel operation Rear panel, printed-circuit-board mounted, lugless connector (TB 202 - 13 positions).

CONTROLS

- DC output Numerical keypad on front panel allows adjustability of either constant voltage or constant current limit points. Resolution of programmed voltage: 10mV on models LLS-6008 and LLS-6018; 100mV on models LLS-6040, LLS-6060, LLS-6120 and LLS-6300. Resolution of programmed current: 100mA on model LLS-6008; 10mA on models LLS-6018, LLS-6040, LLS-6060, LLS-6120 and LLS-6300. Accuracy of programmed value versus delivered output: ±2% or 3 counts, whichever is greater.
- Standby Control Allows for zero output without losing last programmed values for voltage and current.
- On/Off Switch Rocker switch located on front panel.
- Overvoltage control Multi-turn, screwdriver-adjust potentiometer located on front panel.

METERS - Front panel 3 1/2 digit voltmeter and 3 digit ammeter simultaneously monitor output voltage and current. Accuracy of metered value versus delivered output: ±2% or 3 counts, whichever is greater.

CONSTANT VOLTAGE/CONSTANT CURRENT INDICATORS - Located on Front Panel. These displays indicate whether power supply is operating as a constant voltage source or is in current limit.

MOUNTING - One mounting surface. Mounting position not restricted. Units are shipped with removable rubber mounting feet attached to the unit.

PHYSICAL DATA

| | |
|--------------|-----------------------------------|
| Size | 4-9/32" x 3-13/16" x 12 3/4" |
| Weight | 7 lbs., 4 oz net; 8 lbs shipping |
| Finish | Off white, FED STD 595, No. 26622 |

ISOLATION RATINGS

| | |
|------------------------|---|
| Input to output | 3000 Volts rms |
| Output to ground | 500 Volts rms - -6008 to -6040, 1000 volts rms -6060 and -6120, 1600 volts rms - 6300 |
| Input to ground | 1500 Volts rms |

WARRANTY - 3 years, parts and labor.

ACCESSORIES

| | |
|---|-----------|
| Rack Adapter system | LRA 1, 20 |
| Rack Mounting Kit Lambda MATE or GPIB systems. Bench Stand with easy access load terminals. | |

OPERATING INSTRUCTIONS

CONTROLS, INDICATORS, AND FUSES

Front Panel On/Off Switch. Located on the front panel is an On/Off switch which controls the application of input power to the supply. The switch disconnects the input circuit from both sides of the AC line.

Front Panel Programmer. The front panel numerical keypad serves to program both the constant voltage and constant current limit points. Starting with the most significant digit, keying in the desired value followed by an "ENTER" keystroke will institute a new operating limit for either output voltage or current limit, as determined by the programming mode indicators. The programming mode can be switched from voltage to current via the "VOLTAGE/CURRENT" key which functions as a pushbutton toggle.

During a new programming key-in sequence, the front panel digital meter will present the keyed-in value of voltage or current until the "ENTER" key is depressed. Once this occurs, the meter will revert back to measurement mode and present the output voltage or current delivered by the supply. In the event of a programming instruction not being followed by an "ENTER" command, the meter will automatically revert back to measurement mode after approximately ten seconds. The value of the non-entered programming instructions is then lost and any new programming instructions must be started from the most significant digit onwards. At any point during a programming instruction key-in, the meter can be reset back to measurement mode and the programming instruction discarded by depressing the "C/E" key.

If an entered programming instruction is not compatible with the rated output voltage or current of the power supply, the appropriate meter will display an "Err" message and the program instruction will not be carried out. Depressing the "C/E" key, or waiting approximately ten seconds, will reset the meter back to measurement mode.

At any time during operation of the power supply the programmed value of voltage or current can be displayed by momentarily depressing the "ENTER" key. This will change the appropriate front panel meter, as denoted by the programming mode indicator, to display the last programmed value for voltage or current for a period of approximately two seconds. After this time the meter will automatically revert back to measurement mode. Care should be exercised when performing this check so as not to depress the "ENTER" key for more than one second for this will institute the "Slew Down" function, as described below.

The output voltage or current limit points can be ramped up, or down, by utilizing the "Slew Up" or "Slew Down" arrow controls. Depressing the "Up" arrow will cause the output voltage or current (as denoted by the programming mode indicator) to ramp up at a rate which will increase with the length of time that the key is depressed. Similarly, depressing the "Down" arrow (which also serves as the "ENTER" key) will cause the programmed value for either voltage or current to decrease at a rate which will increase with the length of time that the key is depressed.

The output voltage of the supply can be brought to zero, without losing the last programmed values of voltage or current (which is the case when power is switched off), by utilizing the "STANDBY" key. Depressing the "STANDBY" key once will bring the output voltage to zero. Depressing the "STANDBY" key a second time will reinstate the last programmed values of voltage and current. Programmed values of either voltage or current can be changed while the unit is in standby.

Operating mode indicators. Included on the front panel are a pair of Operating Mode indicators which report on whether the power supply is operating as a constant voltage source, or is in current limit. If the output current of the supply is below the programmed value for constant

Current, the operating mode indicator under the voltmeter will illuminate to indicate that the unit is not in current limit. If the load connected to the supply is low enough impedance to draw a current which reaches the programmed current limit point, the unit will crossover into constant current and the operating mode indicator under the ammeter will illuminate.

Fault Indicator. Also included on the front panel is a "FAULT" indicator which will illuminate if either an overvoltage or airflow interruption shutdown occur. When the fault indicator illuminates, all other displays on the panel will go dark.

Overvoltage Control. This is a multi-turn, screwdriver-adjust potentiometer located on the front panel. Rotation of this control will vary the overvoltage limit-point from the minimum specified value (fully CCW) to the maximum specified value (fully CW).

Fuse F101. This is a 10A/250V Normal-Blo fuse located in series with the hot AC power line. This fuse protects the power supply from excessive overcurrents in the event of an internal component failure. For North American operation from nominal 220 VAC inputs, which are derived from two 110 VAC phases (neither line is neutral), it is recommended that the power supply be fused externally in both lines in accordance with appropriate safety agency requirements. **NOTE: POWER MUST BE REMOVED FROM THE UNIT BEFORE CHECKING OR REPLACING THIS FUSE.**

Fuse F103. This is a 3A/250V normal-blo miniature fuse located in series with the main inverter current path. This fuse protects printed circuit board traces in this circuit in the event of an internal component failure. **NOTE: POWER SHOULD BE REMOVED FROM THE UNIT BEFORE CHECKING OR REPLACING THIS FUSE.**

Fuse F201. This is a .25A/125V normal-blo miniature fuse located in series with Pin 6 of TB202 (common) to protect against misconnection of external load.

Line Select Switch S101. This is a screwdriver actuated switch which is accessible through a hole in the rear of the unit. Selection of input voltage range (85-132 or 170-265 VAC) should only be performed with AC power removed from unit.

CONNECTIONS

AC Input. AC input connection should be made using an IEC type, three-prong female connector. An IEC line cord is supplied with the unit.

DC Output. Load connections must be made to two-position terminal block TB201. This block is designed to handle the maximum current and voltage attainable from the supply and will accept a No. 8 Ring-or Spade-type lug.

Sensing. Terminals for sensing output voltage are located on TB202, and are terminals 10 and 12. Local sensing can be achieved by strapping terminal 10 to terminal 11 (connects to +V) and terminal 12 to terminal 13 (connects to -V). See figure 3.

Remote Voltage Programming, Remote Current Programming, Remote On/Off, Remote Resistance Programming, Parallel Operation. Terminals for achieving these functions are located on TB202, pins 1 through 9. See Modes of operation and Operating procedures for details. TB202 is a lugless-type connector which will accept up to an AWG No. 20 stripped wire. Shipped with the unit are a number of ring type solder lugs which can be utilized if multiple wires are to be connected to TB202 positions.

CONNECTIONS (Cont'd)

Load Ground Connection. This power supply can be operated with either the positive or negative terminal grounded, or with neither terminal grounded. A tapped hole in the chassis at the rear of the unit is provided for grounding one of the output terminals, if desired.

NOTE: When operating the supply with neither output terminal grounded, high impedance leakage resistance and capacitance paths can exist between the power supply circuitry and chassis ground.

BASIC MODES OF OPERATION AND OPERATING PROCEDURES

This power supply is designed to operate as a constant-voltage source or as a constant-current source. Automatic crossover to either mode of operation occurs when load conditions change as follows:

Constant Voltage. The power supply will function as a constant-voltage source while the load current is less than the current value I_{LIM} as set by the front panel current-limit programming generator, or, where applicable, by the external current programming signal applied to the RCP terminal. When the load current $I_L (=V_o/R_L)$ reaches I_{LIM} , the supply will crossover automatically and will operate as a constant current source. Further decrease in the value of the load resistor will result in a decrease of voltage across the load while the current remains regulated to I_{LIM} .

Constant Current. The power supply will function as a constant-current source while the load voltage V_L does not exceed the voltage value set by the front panel constant voltage programming generator, or where applicable, by the external programming signal applied to either the RVP terminal or the R_p terminal. When the load resistance is high enough so that the load voltage $V_o (=I_L \times R_L)$ reaches the value set by the programming controls, the supply will automatically crossover and operate as a constant voltage source.

Power Up and Front Panel Initial Settings. Upon initiation of AC power, the front panel constant voltage and constant current generators will be preset to deliver zero output voltage along with a current limit point corresponding to the 40°C rating of the supply, plus 2%. Immediately following power on, the front panel meters will display these programmed values for approximately two seconds before reverting to measurement mode.

To deliver voltage after power up, the desired operating voltage must be entered through the numeric keypad, or the "Slew Up" arrow can be utilized. It should be noted that when the power supply is switched off via the front panel switch, the last entered programming values of voltage and current will be lost. When the power supply is switched back on again, it will power up as described above. If an application requires that power be interrupted to a load, and a quick return to the pre-existing programmed values of voltage and current is desired, the front panel "STANDBY" control can be utilized.

OPERATION AS A CONSTANT-VOLTAGE SOURCE

The output impedance and regulation of the power supply at the load may change when using the supply as a constant-voltage source and connecting leads of practical length are used. To minimize the effect of the output leads on these characteristics, remote sensing can be used. Recommended types of supply-load connections, with local or remote sensing, are described in the following paragraphs.

Local Sensing Connection, Figure 3. Local sensing is the connection suitable for applications with relatively constant load where extremely close load regulation over the full rated current excursion is not required at the load.

Local Sensing Connection, Figure 4. Remote sensing provides complete compensation for the DC voltage drop in the connecting cables. Sensing leads should be a twisted pair to minimize AC pickup. A 2.5UF capacitor may be required between the output terminals and sense terminals to reduce noise pick-up.

SAFETY NOTICE

DANGEROUS VOLTAGES EXIST IN THIS EQUIPMENT. OBSERVE THE USUAL SAFETY PRECAUTIONS WHEN OPERATING OR SERVICING THE EQUIPMENT TO AVOID SHOCK OR INJURY.

Constant-Voltage Operation, Internal Programming, Adjustable Current Limit.

When shipped from the factory, the supply is ready for use as a constant-voltage/constant-current source with automatic crossover. Initial programmed points for constant voltage and constant current are as described in the previous text. Jumpers are in place for local voltage sensing, figure 3. If remote-sensing connection is desired, the load should be wired as shown in figure 4. It should be noted that the front panel voltmeter measures the voltage at the rear panel power terminals and may not accurately reflect voltage at the load in remote sense applications.

Determine load requirements and select wire size from figures 1 and 2.

After applying input power, output voltage can be adjusted to any desired value via the front panel numerical keypad programmer. The current limit point can be adjusted by setting the "PROGRAM MODE" indicator to "AMPS" via the "VOLTAGE/CURRENT" key and then keying in the desired current limit value, followed by an "ENTER" keystroke.

Programmed Constant-Voltage Operation Using a Zero to 5-Volt External Source. The power supply output voltage can be programmed via an external zero to 5-volt source by utilizing the RVP terminal on TB202. The jumper between terminals TB202-1 and -2 should be removed and the external source connected between terminals TB202-2 and -6 (figure 5). Note that terminal 6 is at a voltage slightly higher than that of +V and that any external source connected to terminal 6 must be electrically isolated from both +V and -V. Consult your Lambda sales representative or the Lambda factory for applications which require programming from sources referenced to +V or -V. The constant-voltage operating point will be directly proportional to the external voltage, with zero output voltage corresponding to zero programming and rated output voltage +2% corresponding to 5 volts programming. Remote versus local sensing and current limit set point adjustment are explained in the preceding text.

Programmed Constant-Voltage Operation Using An External Resistor. The power supply output voltage can be programmed via an external resistor by utilizing the Rp terminal on TB202. The external resistor should be connected between TB202 terminal 9 and -V, while the -S terminal (TB202 terminal 12) is not connected (figure 6).

On LLS-6008 through LLS-6120 models, the value of external resistor can be chosen to be any value from 200 ohms per volt (nominal) to 1000 ohms per volt (nominal) by presetting the voltage from RVP terminal TB202-2 to common terminal TB202-6 via the front panel programmer. A 5-volt potential between these terminals corresponds to 200 ohms per volt (nominal) and can be achieved by programming the front panel to full scale voltage (V_O)

(RATED) +2%). A 1-volt potential between these terminals corresponds to 1000 ohms per voltage (nominal) and can be achieved by programming the front panel to 20.4% of the rated voltage.

It should be noted that this programmed value must be re-entered every time AC power is applied to the power supply.

LLS-6300 models require a 1000-ohms-per-volt external programming resistor. The front panel programmer must be set to 306 volts after the application of input power.

In order to protect any external shorting contact made between Rp and -V from seeing excessive current during a programming-down execution, an internal resistor is connected in series with the Rp terminal that limits the maximum peak current out of the Rp terminal to 1 Amp. This resistor will cause a small offset voltage to be present at the output terminals. This offset voltage will range from approximately +0.05 volts on model LLS-6008, set at 200 ohms per volt, to +0.5 volts on model LLS-6120, set at 200 ohms per volt. The magnitude of this offset voltage can be limited by increasing the ohms-per-volt utilized in the application. For example, on model LLS-6008, the offset becomes approximately +0.01 V, set at 1000 ohms per volt, and on model LLS-6300 it becomes approximately +0.27V, set at 1000 ohms per volt. Remote versus local sensing and current limit set point adjustment are as described above under Constant-Voltage operating procedures.

Programmed Constant Voltage Operation Using a One-To-One External Voltage Source Referenced to -V. The power supply output voltage can be programmed via an external one-to-one voltage by utilizing the Rp terminal on TB202. The external voltage source should be connected between Rp terminal (TB202-9) and -V, while leaving -S terminal (TB202-12) disconnected (figure 7). In addition, terminals 7 and 8 should be open circuited.

The external source should be current-limited to no more than 20mA in order to protect internal components in the LLS unit.

In order to limit peak currents in the Rp terminal to approximately one amp during programming up and programming down transients, an internal resistor is included in series with the Rp terminal. Remote versus local-sensing and current-limit set-point adjustment are as described above under Constant Voltage operating procedures.

OPERATION AS A CONSTANT-CURRENT SOURCE

In this mode of operation, when the load voltage increases, due to changing load resistance, to the limit of the front panel constant voltage setting, the power supply crossover circuit will cause the unit to operate as a constant-voltage supply.

SAFETY NOTICE

DANGEROUS VOLTAGES EXIST IN THIS EQUIPMENT, OBSERVE THE USUAL SAFETY PRECAUTIONS WHEN OPERATING OR SERVICING THE EQUIPMENT TO AVOID SHOCK OR INJURY.

Constant-Current Operation, Internal Programming, Adjustable Voltage Limit. When shipped from the factory, the supply is ready for use as a constant-voltage/constant-current source with automatic crossover. Initial programmed points at power up for constant voltage and constant current are as described in the previous text.

Determine load requirements and select wire size from figures 1 and 2.

After applying power, output current and maximum voltage limit point can be adjusted to any desired value via the front panel numerical keypad.

Programmed Constant-Current Operations Using A Zero-to-5-Volt External Source. The power supply output current-limit can be programmed via an external zero-to-5 volt source by utilizing the RCP terminal on TB202. The jumper between terminals TB202-3 and -4 should be removed and the external source should be connected between terminals TB202-4 and -6 (figure 8). Note that terminal 6 is at a voltage slightly higher than that of +V and that any external source connected to terminal 6 must be electrically isolated from both +V and -V. Consult your Lambda sales representative or the Lambda factory for applications which require remote programming from sources referenced to +V or -V. The constant-current operating point will be directly proportional to the external voltage, with zero output corresponding to zero programming and full-rated output-current (at 40°C) +2% corresponding to 5 volts programming. Maximum voltage-limit set-point as described above.

OTHER MODES OF OPERATION

TTL Compatible Remote Turn-On/Turn-Off. A TTL compatible remote turn-on/turn-off function is available by utilizing terminal 5 of TB202. A TTL low signal (0 to 0.5 Volts) or a short between terminal 5 and terminal 6 of TB202 enables the output voltage. A TTL high (2.8 to 5 Volts), or open circuit between terminal 5 and terminal 6 of TB202 will cause the output voltage to go to zero, see figure 9. It should be noted that terminal 6 (common) is at a potentially slightly higher than +V and any TTL signal must be floated from both +V and -V.

Parallel Operation. The output current capability of LLS-6000 power supplies can be increased by connecting supplies of the same output voltage rating in parallel. The supplies can be operated in a MASTER/SLAVE configuration by using the circuit shown in figure 10. The jumper between terminals 7 and 8 of TB202 on the SLAVE unit must be removed, and a connection must be added from terminal TB202-6 of the MASTER unit to terminal TB202-8 of the SLAVE unit. In addition, a jumper should be added between TB202 terminals 6 and 10 of the slave unit. Note that constant-current specifications do not apply in parallel operation.

Series Operation. The voltage capability of LLS-6000 power supplies can be extended by series operation of two power supplies of equal voltage ratings. A maximum of 500 volts can be connected between either the +V or -V terminal and chassis ground. Figure 11 shows the connection for this series operation.

Diodes CR_A and CR_B, which protect the units from carrying excessive current in the event of one unit not being powered up (i.e. fan not operational), must be capable of withstanding the maximum rated-current.

For master/slave operation with auto tracking, TB202 terminals 7 and 8 of the slave unit are disconnected from one another. Also, an external resistor, Rx, is connected from terminal TB202-10 of the master unit to terminal TB202-9 of the slave unit. The value of Rx is 1600 Ω for model LLS-6008, 3600 Ω for model LLS-6018, 8000 Ω for model LLS-6040, 12,000 Ω for model LLS-6060, 24,000 Ω for model LLS-6120 and 300,000 Ω for model LLS-6300. Due to the existence of certain tolerances, the value of Rx required for perfect tracking may vary slightly from the nominal values given here. In addition, Rx must be able to dissipate up to 0.04 watts on model LLS-6008, 0.09 watts on model LLS-6018, 0.2 watts on model LLS-6040, 0.3 watts on model LLS-6060, 0.6 watts on model LLS-6120 and 0.3 watts on model LLS-6300.

Utilization of Remote Features and Implications on Output Noise. When various remote features of the power supply are utilized (such as remote voltage programming, remote current programming, remote TTL compatible on/off or remote resistance programming), or when

power supplies are utilized in parallel or series combinations, output ripple and noise may be slightly degraded due to high-frequency spikes caused by noise radiated thru wires connected to terminals 1 through 9. Normally, the amplitude and spectral content of these spikes is such that a small decoupling capacitor connected at the remote load-distribution-point will adequately attenuate any noise pickup. However, in extremely sensitive applications, where spikes cannot be tolerated, radiated noise emanating from wires connected to terminals 1 through 9 can be minimized by utilizing high-frequency-rated ferrite noise suppressors on each of the externally connected signal wires. In order to be effective, these noise suppressors must be physically located on the signal wire at a point no further than 3 inches from where the wire connects to the power supply terminal. These noise suppressors can either be obtained from your local Lambda sales office or by contacting the factory. Figures 15 and 16 detail the use of these noise suppressors.

These suppressors are built into the unit for the +S and -S terminals and no external suppressors are required to minimize noise radiation while using remote sensing.

ADJUSTMENT OF FRONT PANEL OVERVOLTAGE CONTROL

The overvoltage protection circuit provides an adjustable means of shutting down the power supply if the output voltage exceeds a pre-determined safe value. In the event of an overvoltage shutdown, the main power oscillator is disabled along with all output bias supplies and the fan supply. A front panel indicator light will turn on to indicate a fault condition. Once the cause of the overvoltage has been determined and removed, the shutdown circuit can be reset by turning off AC power to the unit via the front panel ON/OFF switch for approximately 10 seconds.

The procedure for setting the overvoltage control is as follows:

(The power supply should be removed from associated equipment, be at an ambient temperature of 25-30°C and operated at nominal line voltage.)

1. The recommended voltage protection point is 115% of the selected power supply operating voltage or 1.5 volts above the selected operating voltage, whichever is greater. (If set too low, load-off transients may cause the overvoltage detection circuit to trip.)
2. Turn the OV adjust control fully clockwise.
3. Apply AC power to the unit and adjust the output voltage to the desired protection point. If the power supply does not have adequate output range to reach this point omit steps 4 and 5, and proceed to step 6.
4. Slowly rotate the OV adjust control CCW while monitoring the front panel display. When the front panel meters go dark and the front panel indicator light comes on, the OV shutdown point has been reached.
5. The voltage protection point is now set. Turn the unit off for approximately 10 seconds to reset the shutdown circuit. When power is switched back on, the initial programmed points for voltage and current will be as described under POWER UP and FRONT PANEL INITIAL SETTINGS.

6. If the power supply adjustment range is not adequate to reach the desired OV protection point, proceed as follows:

(a) Adjust the power supply output to the normal operating voltage.

(b) Slowly turn the OV adjust control R501 CCW until the front panel meters go dark and the front panel fault light comes on.

(c) Refer to the chart below, select the appropriate volts/turn ratio and turn the OV adjust control clockwise by the number of turns equivalent to 115% of the operating voltage (or 1.5 volts, whichever is greater) to bring the OV set-point to the proper value.

| MODEL | NOMINAL VOLTS PER TURN (OV ADJ) |
|----------|---------------------------------|
| LLS-6008 | 0.6 |
| LLS-6018 | 1.7 |
| LLS-6040 | 3.5 |
| LLS-6060 | 5.2 |
| LLS-6120 | 9.2 |
| LLS-6300 | 22.5 |

OPERATION AFTER PROTECTIVE DEVICE SHUTDOWN

Thermal Shutdown. The thermal shutdown circuit will activate if any interruption to normal cooling airflow occurs (such as a blocked air inlet or fan rotor lockup). When a thermal shutdown occurs, the main oscillator circuit will be inhibited, thereby bringing the supply output to zero and causing the front-panel meters to go dark and fault-indicator to light. In order to reset the unit after a thermal shutdown, first determine and remove the cause(s) of airflow interruption, and then remove power from the unit for at least 10 seconds, if the unit has already cooled down. (If the unit is not cooled down, remove power for up to 2 minutes immediately after a thermal-shutdown occurrence).

Fuse Shutdown. Fuses will blow when the maximum rated current value for the fuses are exceeded. Fatigue failure of fuses can occur when mechanical vibrations from the installation combine with thermally induced stresses to weaken the fuse metal. Many fuse failures are caused by a temporary condition and replacing the blown fuse will make the fuse-protected circuit operative.

NOTE: Power should be removed from the unit before checking or replacing any fuse.

Overvoltage Shutdown. When the power supply output increases above the overvoltage limit, the overvoltage protection circuit will shut down the main oscillator's operation, thereby causing the output voltage to go to zero. During voltage shutdown, the front panel meters will go dark and the fault indicator lamp will be lit. After eliminating the cause(s) for overvoltage, resume operation of the power supply by turning off the unit for a period of at least 10 seconds. (refer to TROUBLESHOOTING CHART).

MAINTENANCE

GENERAL

This section describes trouble analysis routines, replacement procedures and calibration and test procedures that are useful for servicing this Lambda power supply. A trouble chart is provided as an aid for the troubleshooter. Refer to the section on SPECIFICATIONS AND FEATURES for minimum performance standards.

PERIODIC MAINTENANCE

The unit should be disconnected from associated equipment and inspected for dust accumulation due to forced-air cooling. Inspect every six months or more often if operated in extremely dusty environments. To inspect the interior of the unit, first connect AC input power to the unit and then remove the top cover by removing the four screws securing the cover. If the unit shows any dust accumulation, it should be vacuumed clean in order to assure proper heat-sink efficiency.

TROUBLE ANALYSIS

Whenever trouble occurs, systematically check all fuses, primary power lines, external circuit elements, and external wiring for malfunction before troubleshooting the equipment. Failures and malfunctions often can be traced to simple causes such as improper jumper and supply-load connections or fuse failure due to metal fatigue.

Use the electrical schematic diagram and block diagram, figure 14, as an aid to locating trouble causes. The schematic diagram contains various circuit voltages that are averages for normal operation. Measure these voltages using the conditions for measurement specified on the schematic diagram. Use measuring probes carefully to avoid causing short circuits and damaging circuit components.

CHECKING TRANSISTORS AND CAPACITORS

Check transistors with an instrument that has a highly limited current capability. Observed proper polarity for PNP or NPN transistors to avoid error in measurement. The forward transistor resistance is low but never zero; backward resistance is always higher than the forward resistance.

For good transistors, the forward resistance for any junction is always greater than zero.

Do not assume trouble is eliminated when only one part is replaced. This is especially true when one transistor fails, causing other transistors to fail. Replacing only one transistor and turning power on, before checking for additional defective components could damage the replaced component.

When soldering semi-conductor devices, wherever possible, hold the lead being soldered with a pair of pliers placed between the component and the solder joint to provide an effective heat sink.

NOTE: The leakage resistance obtained from a simple resistance check of a capacitor is not always an indication of a faulty capacitor. In all cases the capacitors are shunted with resistances, some of which have low values. Only a dead short is a true indication of a shorted capacitor.

PRINTED CIRCUIT BOARD MAINTENANCE TECHNIQUES

1. If foil is intact but not covered with solder, it is a good contact. Do not attempt to cover with solder.
2. In some cases, voltage measurements can be made from either side of the board. Use a needle-point probe to penetrate to the wiring whenever a protective coating is used on the wiring. A brass probe can be soldered to an alligator clip adapted to the measuring instrument.
3. Whenever possible, use a heat sink when soldering transistors.
4. Broken or damaged printed wiring is usually the result of an imperfection, strain, or careless soldering. To repair small breaks, tin a short piece of hook-up wire to bridge the break, and holding the wire in place, flow solder along the length of wire so that it becomes part of the circuitry.
5. When unsoldering components from the board, never pry or force loose the part; unsolder the component by using the wicking process described below:
 - (a) Select a 3/16 inch tinned copper braid for use as a wick; if braid is not available, select AWG No. 14 or No. 16 stranded wire with 1/2 inch insulation removed.
 - (b) Dip the wick in liquid rosin flux.
 - (c) Place the wick onto the soldered connection and apply soldering iron onto the wick.
 - (d) When sufficient amount of solder flows onto the wick, freeing the component, simultaneously remove iron and wick.

NOTE: When dealing with surface-mount technology parts, devices with two leads can be removed with a pair of tweezers and a soldering iron first by heating both ends of the device until the solder is melted and then by quickly removing the part with the tweezers. Replacement first requires pre-wetting the mounting pads with a small amount of solder and then holding the new part in place with the tweezers. First one end of the part is heated and then the other end is heated to the point where the solder melts and flows onto the part, thereby forming new solder joints. Care should be exercised to avoid damaging the part(s) because of accidental overheating or mechanical stress.

Removal or repair of SMT devices, which have more than two leads, is best left to SMT repair stations specifically designed to handle removal and installation of these parts using special tools and techniques.

TROUBLE CHART

The trouble chart is intended as a guide for locating trouble causes and is to be used along with the schematic diagram.

The operating conditions assumed for the trouble chart are as follows:

- (a) AC power of proper voltage and frequency is present at input terminals.

(b) Power supply is connected for constant voltage with local sensing.

(c) Front panel programmed for full scale voltage and current unless otherwise noted.

SAFETY NOTICE

DANGEROUS VOLTAGES, DUE TO CHARGED CAPACITORS, MAY EXIST IN THIS EQUIPMENT EVEN IF AC POWER IS REMOVED. OBSERVE NORMAL SAFETY PRECAUTIONS WHEN SERVICING.

TROUBLESHOOTING CHART

| <u>Symptom</u> | <u>Probable Cause</u> | <u>Remedy</u> |
|--|---|--|
| 1. Zero volts DC output (with front panel programmed for maximum voltage and current.) | Short circuit across output of supply. | Check load connections. Correct as necessary. |
| <u>Additional symptoms</u> | | |
| A. OV/OT fault indicator light on. | Overvoltage fault | See manual section on procedure for setting OV adjust. |
| | Overtemperature fault | Check for locked rotor on fan. Check for air inlet blockage. |
| B. Front panel operational. | Panel not programmed properly | See manual section on procedure for programming front panel. |
| C. Front panel operational. 5 volts measured from RVP to common and from RCP to common. Zero or negative voltage from IC208 pin 7 to common. | IC204, IC205 or IC208 defective. | Check and replace as necessary. |
| D. Front panel operational. 5V measured from RVP and RCP to common. Greater than 5V from IC208 pin 7 to common. | IC206, Q202 defective. CR116, CR117 open. C103 shorted. | Check and replace as necessary. Check and replace as necessary. |
| E. Front panel operational. RVP or RCP to common do not measure 5V. | Front panel circuitry defective. F201 open | See section of TROUBLESHOOTING CHART referring to front panel. |

TROUBLESHOOTING CHART (Cont'd)

| <u>Symptom</u> | <u>Probable Cause</u> | <u>Remedy</u> |
|---|---|--|
| Zero output continued: | Open circuit at remote on/off terminal TB202-5. | Checkout wiring. Correct as necessary. |
| | IC211 or IC215 defective. | Check and replace as necessary. |
| F. Front panel not operational. | Ribbon cable from J202 to front panel is disconnected. | Check and repair as necessary. |
| G. Front panel not operational Ribbon to J202 ok. | Front panel circuitry defective. IC203 defective. | See section of TROUBLESHOOTING CHART referring to front panel. Check and replace as necessary. |
| H. RVP to common or RCP to common do not measure I. Fan not operational. Output of bias regulators IC201 and IC202 not +/-12V (respectively). Inputs ok. | IC201, IC202 defective. C203, 205 shorted. F201 open. | Check and replace as necessary. |
| I. Same as above, except inputs of IC201/202 not correct. | Oscillator circuit not operational. | See below. |
| | CR114, CR115, CR118, CR119 defective. | Check and replace as necessary. |
| J. Front panel not operational. F101, F103 not blown. No oscillator waveform at Q102. | IC101 defective, Q103 shorted. CR113 shorted. | Check and replace as necessary. |
| K. F101 blown. F103 ok. | CR101, C105, C107 shorted. | Check and replace as necessary. |
| L. F101 or F103 blown. | Q101, Q102 shorted. | Check and replace as necessary. |
| 2. High output voltage, control of output. | Open sense lead. | Refer to appropriate connection diagram and correct as required. |

TROUBLESHOOTING CHART (Cont'd)

| <u>Symptom</u> | <u>Probable Cause</u> | <u>Remedy</u> |
|--|--|---|
| Zero output continued: | | |
| 3. Unit cannot be adjusted to attain rated V_o or I_o or minimum output. | Unit out of calibration. | Refer to CALIBRATION PROCEDURES in manual and re calibrate unit in the proper sequence. |
| 4. Unit will not program down to zero output. | IC207, Q201, IC213, IC212, Q205 defective. | Check and replace as necessary. |

TROUBLESHOOTING CHART - FRONT PANEL

| <u>Symptom</u> | <u>Probable Cause</u> | <u>Remedy</u> |
|--|---|---|
| 1. Front panel display dark. Power supply operational (fan running). | Ribbon cable from J202 to front panel disconnected. | Check and repair as necessary. |
| | Ribbon cable from J602 to J501 disconnected. | Check and repair as necessary. |
| <u>Additional Symptoms</u> | | |
| A. 5 volts not measured from pin 3 of IC601 (micro-controller) to TP2. | IC203 (+5V Regulator) defective | Check and repair as necessary. |
| B. 5 volts measured from pin 3 of IC601 to TP2. | IC601 defective. | Check and repair as necessary. |
| 2. Panel will not program to rated output. | Power supply out of calibration. | Refer to CALIBRATION procedure and recalibrate unit in proper sequence. |
| | Front panel not initialized properly. | Refer to chart below for proper S601 settings. |
| | IC605 (D to A converter), IC608 (buffer amplifier) defective. | Check and replace as necessary. |

TROUBLESHOOTING CHART (Cont.d)

| <u>Symptom</u> | <u>Probable Cause</u> | <u>Remedy</u> |
|--|---|---|
| 3. Panel will not measure voltage or current properly. | Power supply out of calibration. | Refer to CALIBRATION procedure and recalibrate unit in proper sequence. |
| | Front panel not initialized properly. | Refer to chart below for proper S601 settings. |
| | IC605 (D to A converter), IC607 (switched capacitor interface). IC609 (current signal amplifier), IC610 (measurement comparator) defective. | Check and replace as necessary |

FRONT PANEL INITIALIZATION - S601 SWITCH SETTINGS

| MODEL | S601 BIT | | | | | | | | | |
|----------|----------|-----|-----|-----|-----|-----|-----|-----|---|----|
| | 1 | 2 | 3 | 4 | 5 | 6 | 7 | 8 | 9 | 10 |
| LLS 6008 | OFF | OFF | OFF | ON | ON | OFF | ON | OFF | * | * |
| LLS 6018 | ON | OFF | OFF | ON | ON | ON | ON | ON | * | * |
| LLS 6040 | OFF | ON | OFF | OFF | ON | ON | OFF | ON | * | * |
| LLS 6060 | ON | ON | OFF | OFF | OFF | OFF | OFF | ON | * | * |
| LLS 6120 | OFF | OFF | ON | ON | ON | OFF | OFF | OFF | * | * |
| LLS 6300 | ON | OFF | ON | OFF | ON | ON | ON | ON | * | * |

*Bits 9 and 10 should be on for all models except during calibration of the front panel, when they both should be off.

PERFORMANCE CHECKS

Checks With Constant Voltage Operation. Check the ripple and regulation of the power supply using the test connection diagram shown in figure 12. Use suggested test equipment or equivalent to obtain accurate results. Refer to SPECIFICATIONS AND FEATURES for minimum performance standards.

Load regulation can be checked by varying the load from no-load to full-load while monitoring the output voltage. Line regulation can be measured by varying the input with a variac between low line and high line while observing the output voltage. Good technical judgement should be observed in the routing and layout of test leads to minimize AC pickup.

Output ripple should be measured directly at the power output terminals of the power supply. A 20 MHz bandwidth oscilloscope should be used. In order to minimize pickup from close proximity radiated fields, the length of the ground wire on the scope probe should be minimal. A true RMS voltmeter similar to a FLUKE 8920A should be used to measure RMS output ripple.

Checks With Constant Current Operation. Check the regulation of the power supply using the test connection diagram shown in figure 13. Refer to SPECIFICATIONS AND FEATURES for minimum performance standards.

Load regulation can be checked by switching from a short-circuit to a maximum-output voltage condition while monitoring the output current through a current-measuring shunt. Line regulation can be measured by varying the input line with a variac while monitoring the output current via a current-measuring shunt. In order to measure the relatively small regulation signal, a shunt of sufficient large voltage drop should be used.

Constant current RMS ripple should be measured by connecting a true RMS voltmeter across the current measuring shunt. A low-pass filter comprised of a resistor and capacitor may be required to filter out high frequency noise spikes due to shunt inductance and pickup.

POWER SUPPLY CALIBRATION PROCEDURE

The following is a list of calibration controls located within the LLS-6000 power supply:

R202 Vo(min) adjust
R223 Vo(max) adjust
R204 Io(min) adjust
R264 Io(max) adjust
R210 Vo(meas) adjust
R623 Io(min) meas adj
R634 Io(max) meas adj

Calibration of R202 must always be performed together with that of R223. Calibration of R204 must always be performed together with that of R264. Calibration of R632 must always be performed together with that of R634.

Before performing any calibrations, the power supply must be removed from associated equipment and must be at an ambient of 25 to 30°C. Unit must be wired in local sense with internal programming, figure 3, and must be operating from a nominal AC line.

Calibration of Output-Voltage-Range Controls R202 and R223.

1. With no load on the output of the power supply, program the front panel voltage programmer for zero.
2. While monitoring the output voltage with an external DVM, adjust R202 so that V_o is between -0.01 and 0 volts.

NOTE: In certain applications it may be desirable to have the minimum output less than zero volts. This can be achieved by adjusting R202 CCW until the minimum output goes down to the desired value, with a $-0.1V$ absolute minimum.

3. Program the front panel voltage programmer for the rated output voltage of the supply.
4. Adjust R223 until the output voltage monitored from $+V$ to $-V$ with an external DVM indicates the rated output voltage of the supply ± 0.01 volts.
5. Seal R202 and R223 with RTV sealant.

Calibration of Output-Current-Range Controls R204 and R264.

1. With no load on the output of the power supply, program the front panel current programmer for zero.
2. Apply a short-circuit through a measurement shunt connected across the output of the supply, figure 13.
3. Adjust R204 until the measured output current measured via the external shunt is between -0.01 and $+0.01$ amps.

4. Program the front panel current programmer for the rated 40°C output current of the supply.

Note: Some value of output voltage must be programmed to produce output current.

5. Adjust R264 until the monitored output current measured via the external shunt is the rated 40°C current of the supply +/-0.01%.

6. Seal R204 and R264 with RTV sealant.

Calibration of Vo(meas) adjust R210.

1. With AC power removed from the supply, set bits 9 and 10 of S601, located on the front panel P.C. board F, to the OFF position.

2. Apply power to the unit. Program for rated output voltage with no load connected at the output.

3. Adjust R210 until the reading presented by the front panel voltmeter corresponds with that of an external DVM connected from +V to -V.

4. Remove power to the supply. Reset bits 9 and 10 of S601 to the ON position. Seal R210.

Calibration of Io(min) measure R632 and Io(max) measure R634.

1. With AC power removed from the supply, set bits 9 and 10 of S601 located on front panel P.C. Board F, to the off position.

2. Apply power to the unit. With no load connected at the output, monitor the voltage between test points TP1 and TP2 located at the top of front panel P.C. Board F. Adjust R632 (potentiometer located closest to the top of the P.C. Board F) so that the voltage between TP1 and TP2, as measured with an external DVM, is between +0.01 and -0.01 volts. Seal R632.

3. Apply a short circuit across the output terminals of the supply through a current measurement shunt.

4. Program the supply for rated voltage and rated current.

5. Adjust R634 so that the reading presented by the front panel ammeter agrees with that of the external shunt. Seal R634.

6. Remove power to the unit. Reset bits 9 and 10 of S601 to the ON position.

SERVICE

When additional instructions are required or repair service is desired, contact the nearest Lambda office where trained personnel and complete facilities are ready to assist you.

Please include the power supply model and serial number together with complete details of the problem. On receipt of this information Lambda will supply service data or advise shipping for factory repair service.

All repairs not covered by the warranty will be billed at cost and an estimate forwarded for approval before work is started.

PARTS ORDERING

Standard components and special components in the Lambda power supply can be obtained from the factory. In case of emergency, critical spare parts are available through any Lambda office.

The following information must be included when ordering parts:

1. Model number and serial number of power supply and purchase date.
2. Lambda part number.
3. Description of part together with circuit designation.
4. If part is not an electronic part, or is not listed, provide a description, function and location of the part.

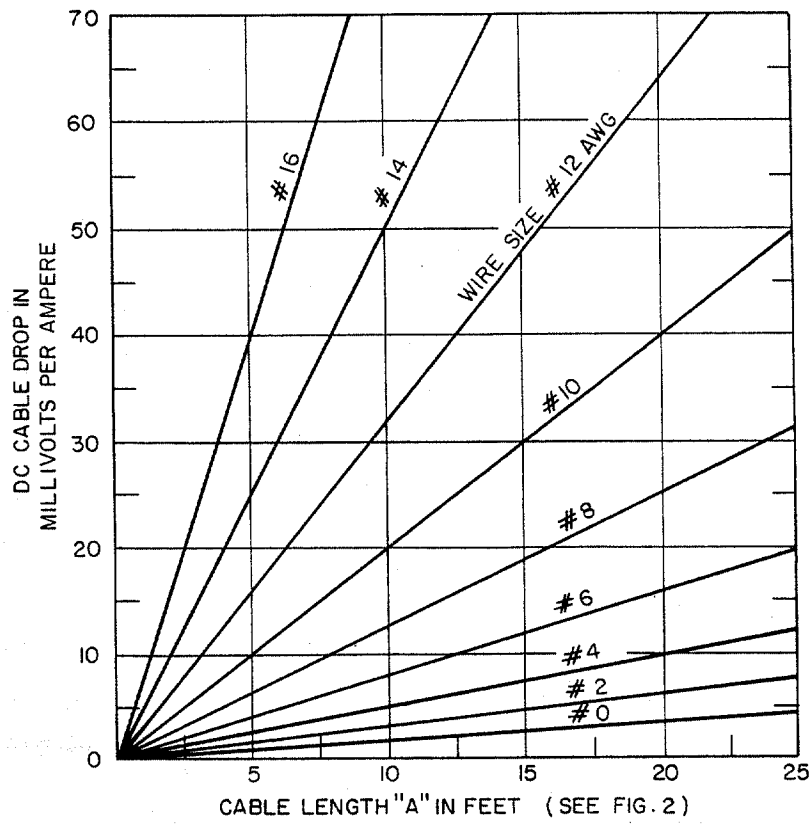

Figure 1. Cable Connection Chart

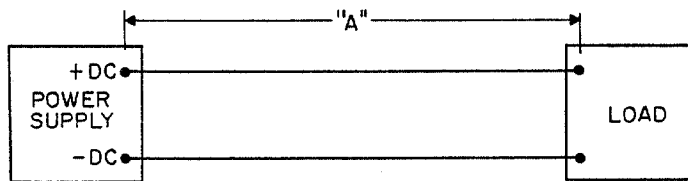
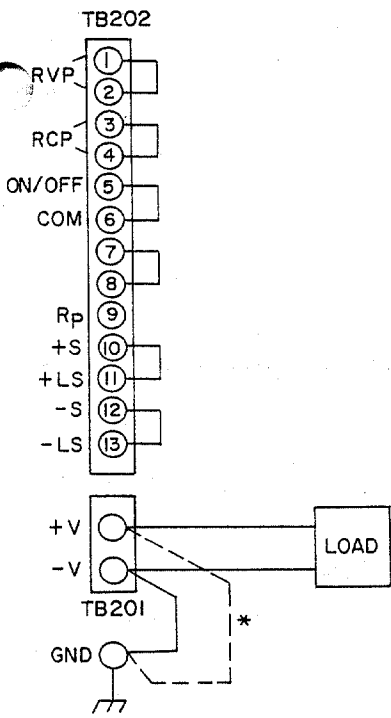

Figure 2. Cable Length "A" in Feet.



NOTE :

* FOR POSITIVE GROUND, DISCONNECT JUMPER FROM -V TO GND AND RECONNECT FROM +V TO GND.

Figure 3. Local Sensing Connection.

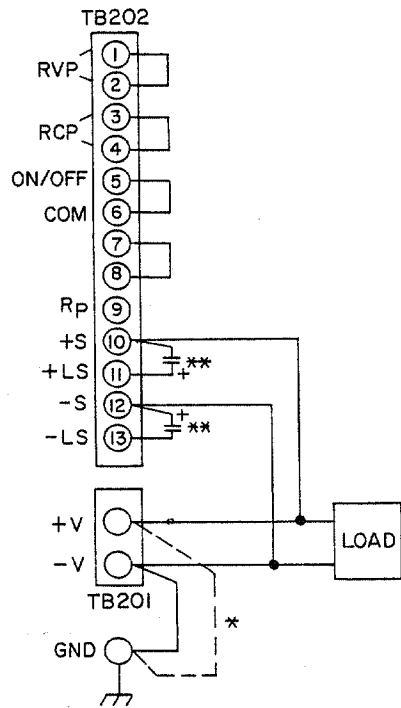

NOTE :

* FOR POSITIVE GROUND, DISCONNECT JUMPER FROM -V TO GND AND RECONNECT FROM +V TO GND.

** A 2.5MF, ELECTROLYTIC CAP. MAYBE REQUIRED.

Figure 4. Remote Sensing Connection.

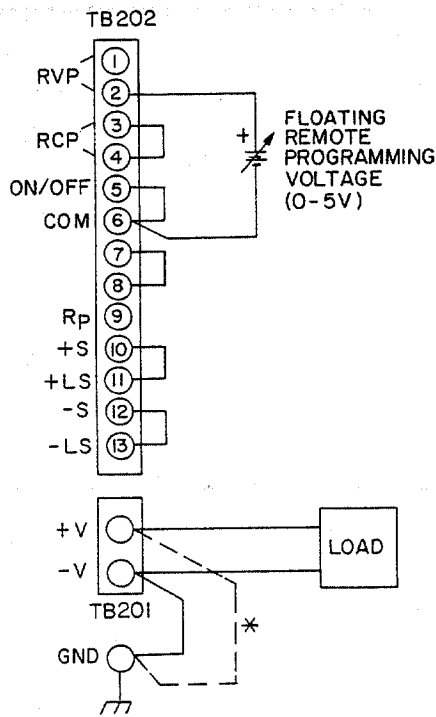

(A) LOCAL SENSING

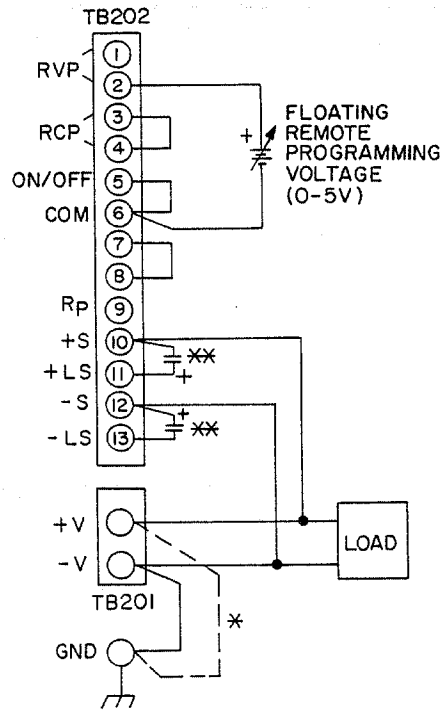

(B) REMOTE SENSING

NOTE :

* FOR POSITIVE GROUND, DISCONNECT JUMPER FROM -V TO GND AND RECONNECT FROM +V TO GND.

** A 2.5MF ELECTROLYTIC CAP. MAY BE REQUIRED.

Figure 5. Programmed Constant Voltage Using a Zero to 5V External Source

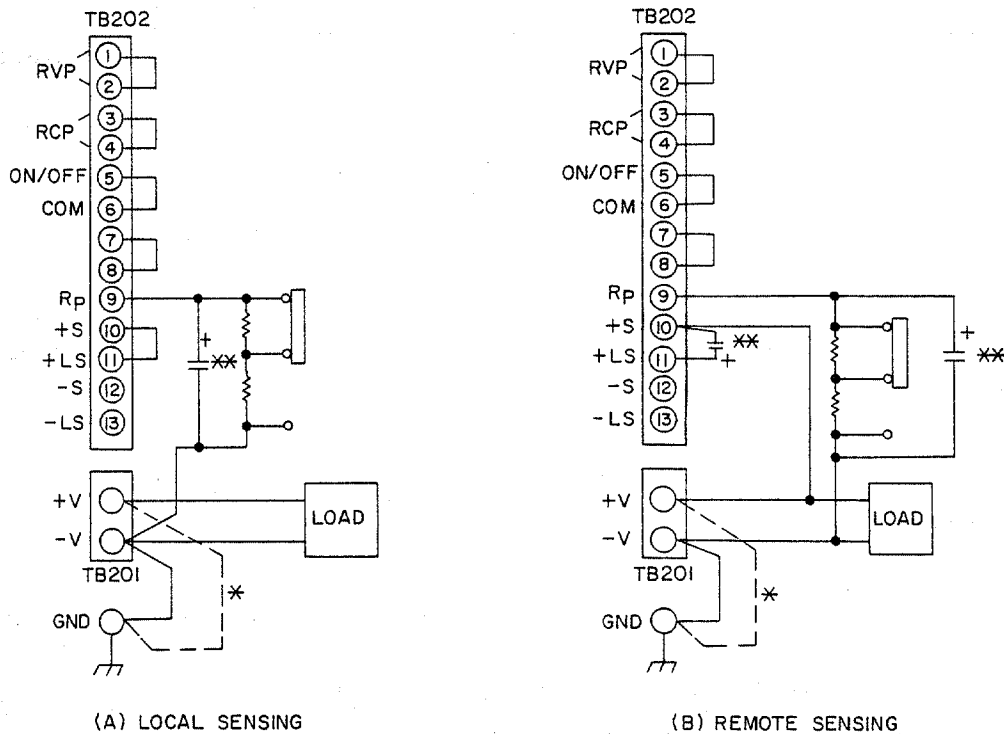

NOTE:
 * FOR POSITIVE GROUND, DISCONNECT JUMPER FROM -V TO GND AND RECONNECT FROM +V TO GND.
 ** A 2.5UF ELECTROLYTIC CAP MAY BE REQUIRED.

Figure 6. Programmed Voltage Using an External Resistor.

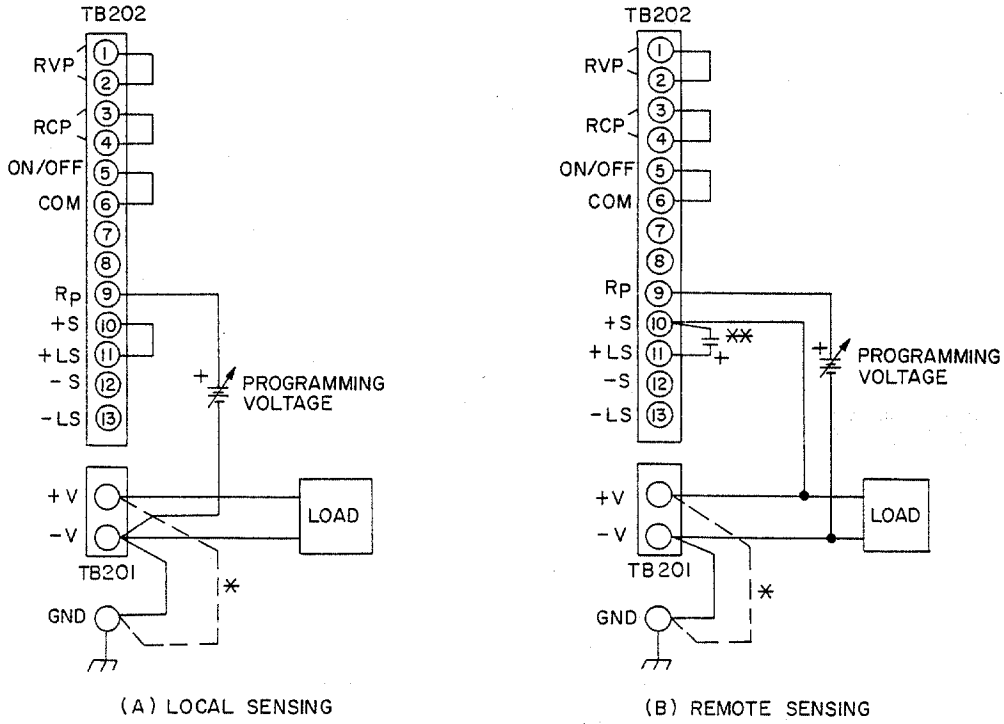

NOTE:
 * FOR POSITIVE GROUND, DISCONNECT JUMPER FROM -V TO GND AND RECONNECT FROM +V TO GND.
 ** A 2.5MF, ELECTROLYTIC CAP MAY BE REQUIRED.

Figure 7. Programmed Voltage Using an External Voltage Source Referenced to -V.

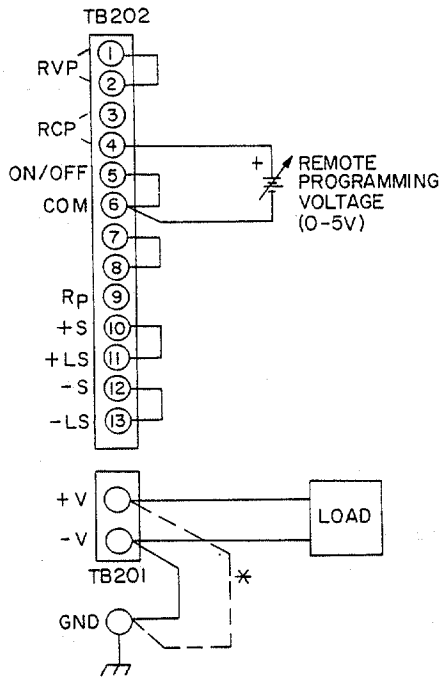

NOTE:
 * FOR POSITIVE GROUND, DISCONNECT JUMPER FROM -V TO GND AND RECONNECT FROM +V TO GND.

Figure 8. Programmed Constant Current with a Zero to 5V External Source.

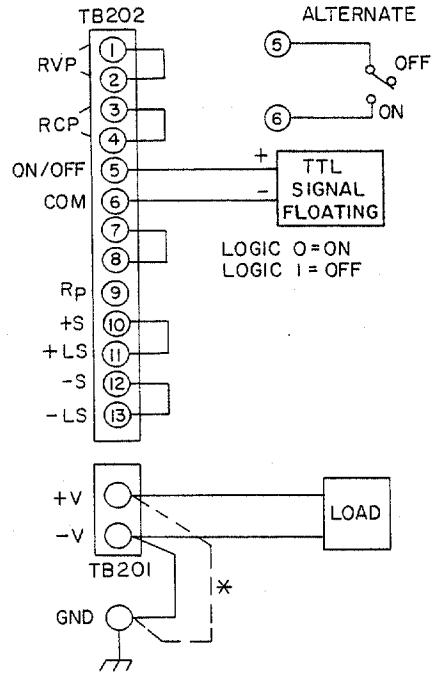

NOTE:
 * FOR POSITIVE GROUND, DISCONNECT JUMPER FROM -V TO GND AND RECONNECT FROM +V TO GND.

Figure 9. TTL Compatible Remote On/Off.

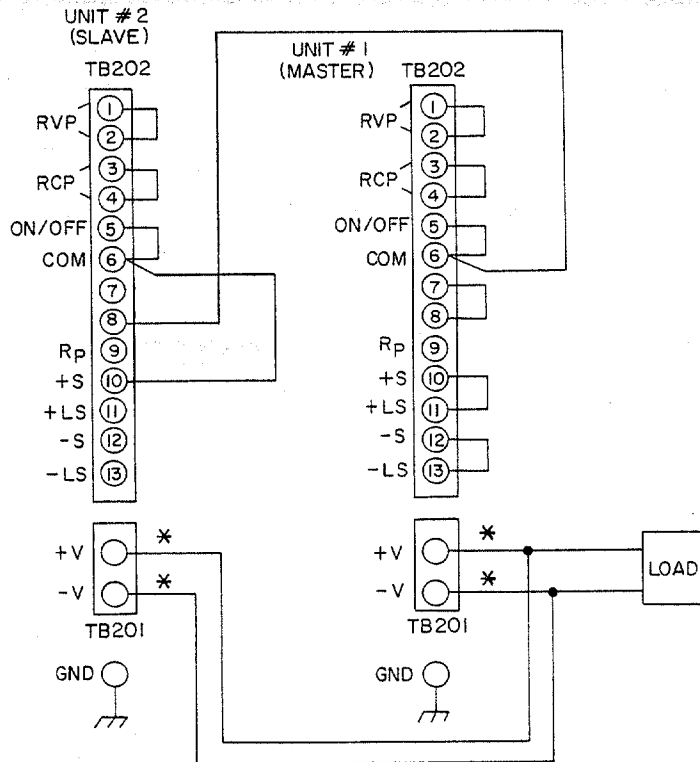

NOTE: * VOLTAGE DROP ON THESE WIRES SHOULD BE BALANCED TO PROVIDE FOR PROPER CURRENT SHARING.

Figure 10. Parallel Operation.

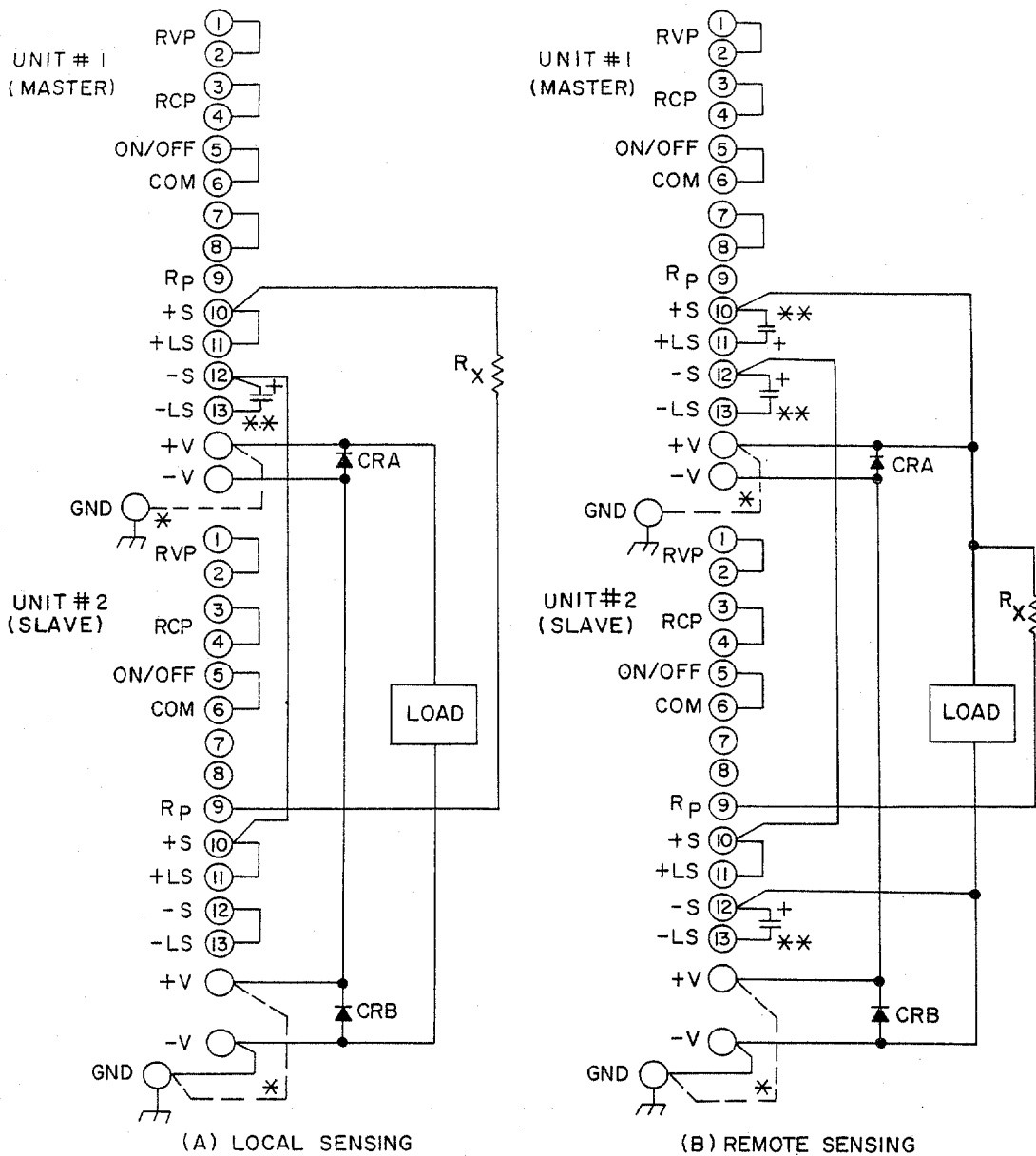

NOTE: * MAKE ONLY ONE GROUND CONNECTION FOR SERIES COMBINATION. TO CHANGE GROUND AS SHOWN, REMOVE JUMPER FROM -V TO GND AND RECONNECT AS DESIRED.
 ** A 2.5UF ELECTROLYTIC CAP. MAY BE REQUIRED.

Figure 11. Series Connection.

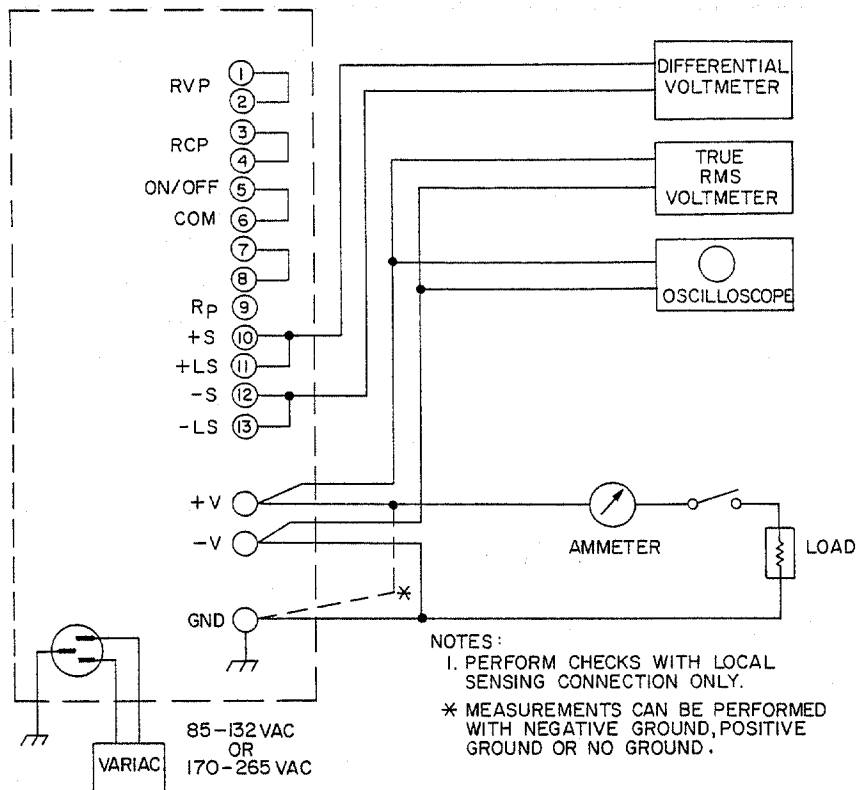

Figure 12. Test Connections for Constant Voltage Performance Checks.

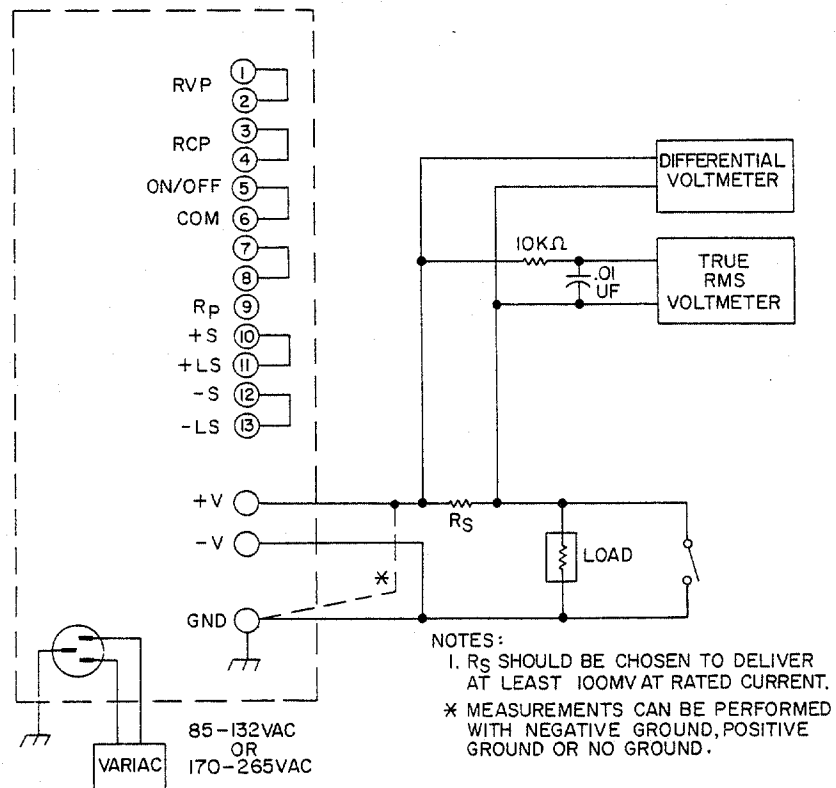

Figure 13. Test Connections for Constant Current Performance Checks.

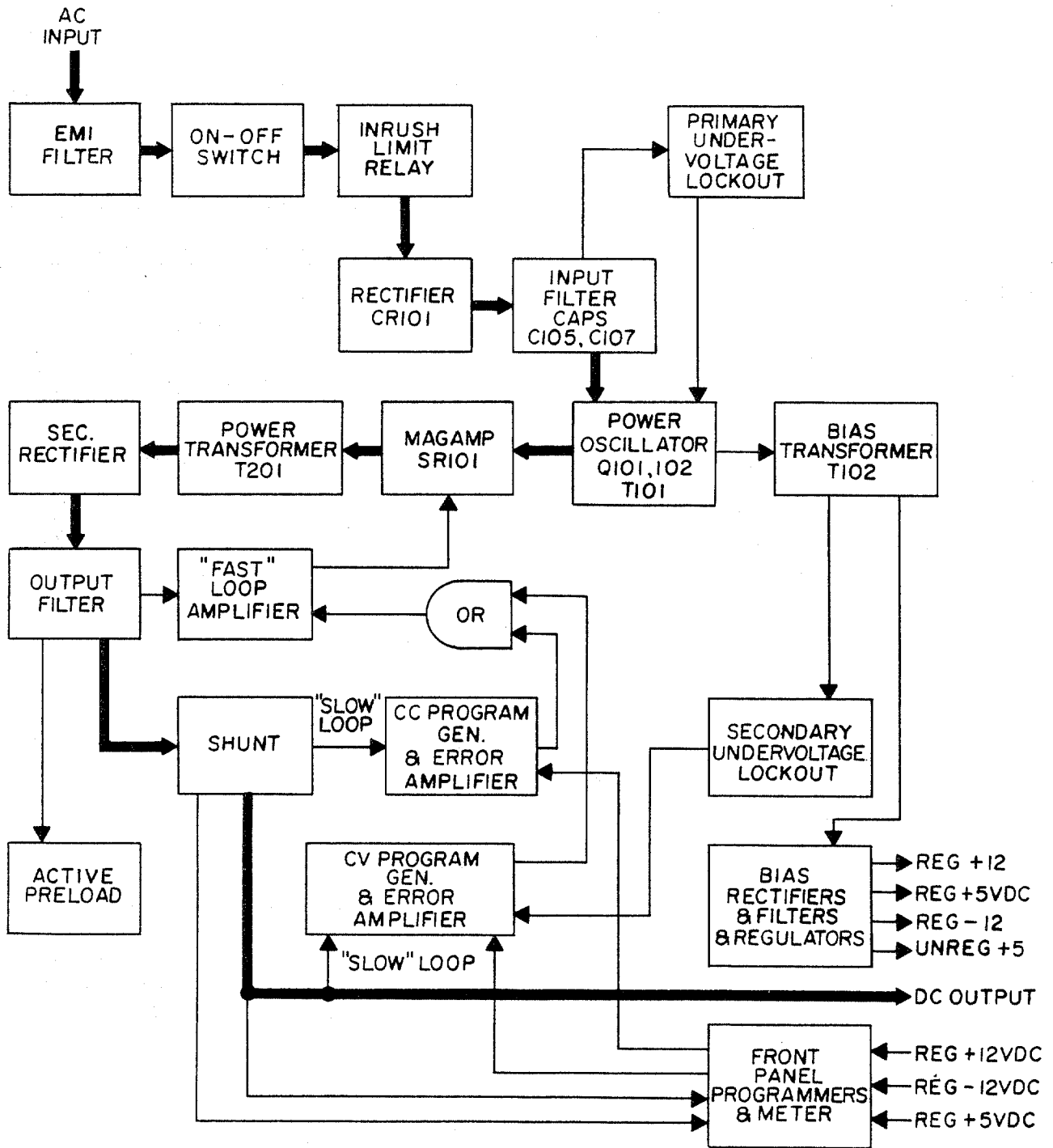
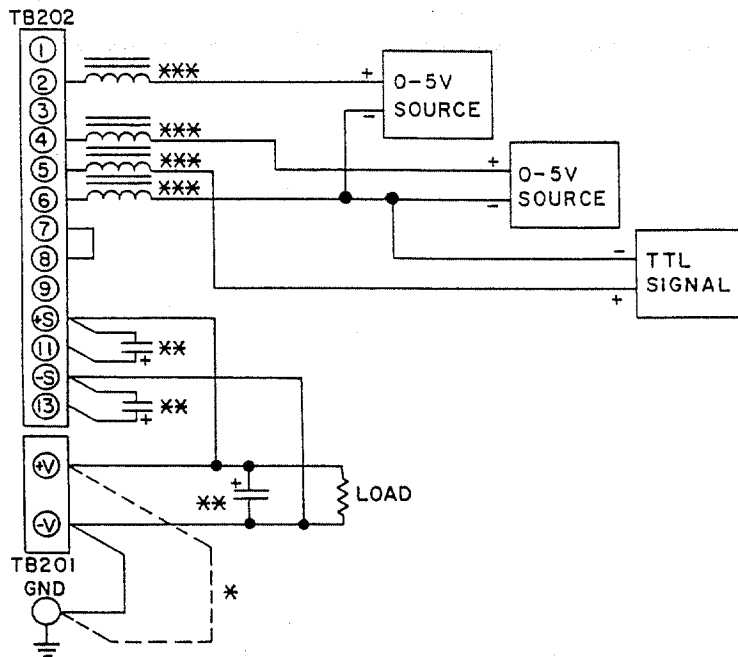
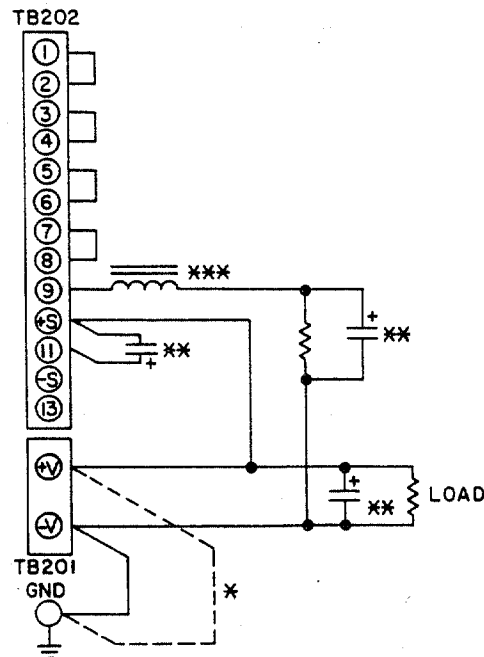

Figure 14. Block Diagram



(A) REMOTE VOLTAGE PROGRAMMING (PIN 2), REMOTE CURRENT PROGRAMMING (PIN 4), REMOTE ON/OFF (PINS 5, 6), REMOTE SENSE.



(B) REMOTE RESISTANCE PROGRAMMING (PIN 9), REMOTE SENSE.

NOTE: * FOR POSITIVE GROUND DISCONNECT JUMPER FROM -V TO GND AND RECONNECT FROM +V TO GND.

** A 2.5UF ELECTROLYTIC CAP MAY BE REQUIRED.

*** NOISE SUPPRESSOR IS 8 TURNS ON FAIR RITE PRODUCTS CORP. CORE NO. 5961001103 AND IS CONNECTED WITHIN 3" OF POWER SUPPLY TERMINALS.

Figure 15. Application of Noise Suppressors in Remote Application Where Extremely Low Noise is Required

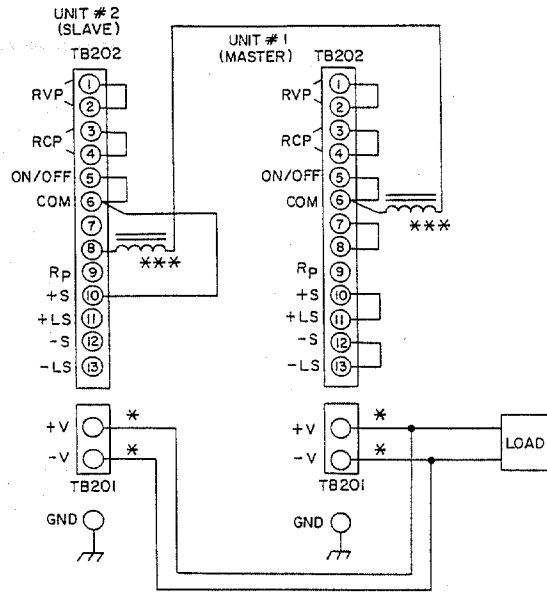

(A) PARALLEL OPERATION

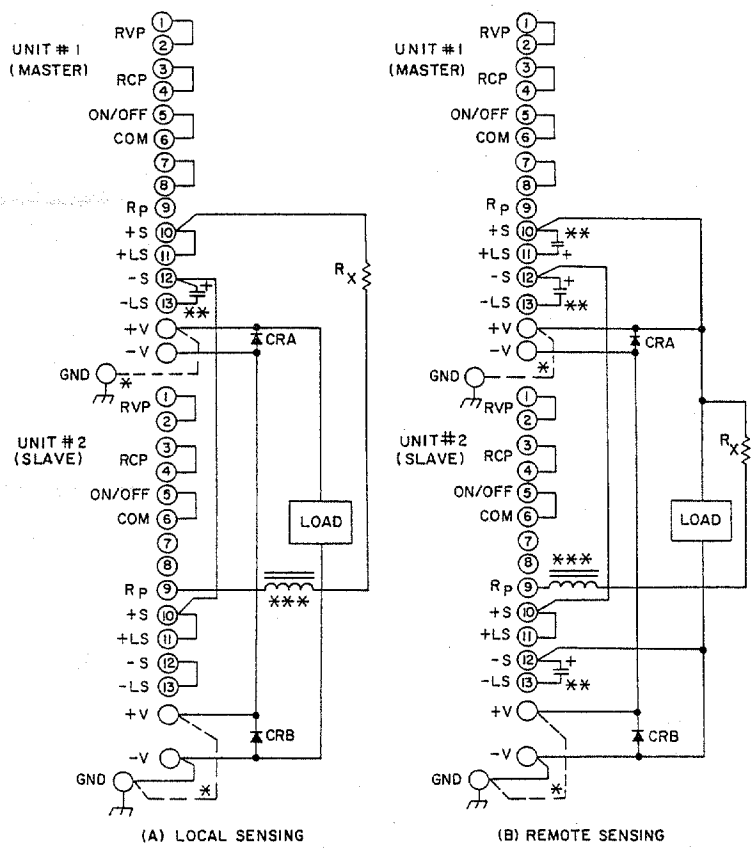

(A) LOCAL SENSING (B) REMOTE SENSING
(B) SERIES OPERATION

NOTE: * MAKE ONLY ONE GROUND CONNECTION FOR SERIES COMBINATION. TO CHANGE GROUND AS SHOWN, REMOVE JUMPER FROM -V TO GND AND RECONNECT AS DESIRED.

** A 2.5UF ELECTROLYTIC CAP. MAY BE REQUIRED.

*** NOISE SUPPRESSOR IS 8 TURNS ON FAIR RITE PRODUCTS CORP. CORE NO. 5961001103 AND IS CONNECTED WITHIN 3" OF POWER SUPPLY TERMINALS.

Figure 16. Application of Noise Suppression in Parallel and Series Operation Where Low Noise is Required.

NOTES:

I. CUSTOMER MUST PROVIDE CLEARANCE FOR VENT HOLES TO ALLOW FOR AIR CIRCULATION.

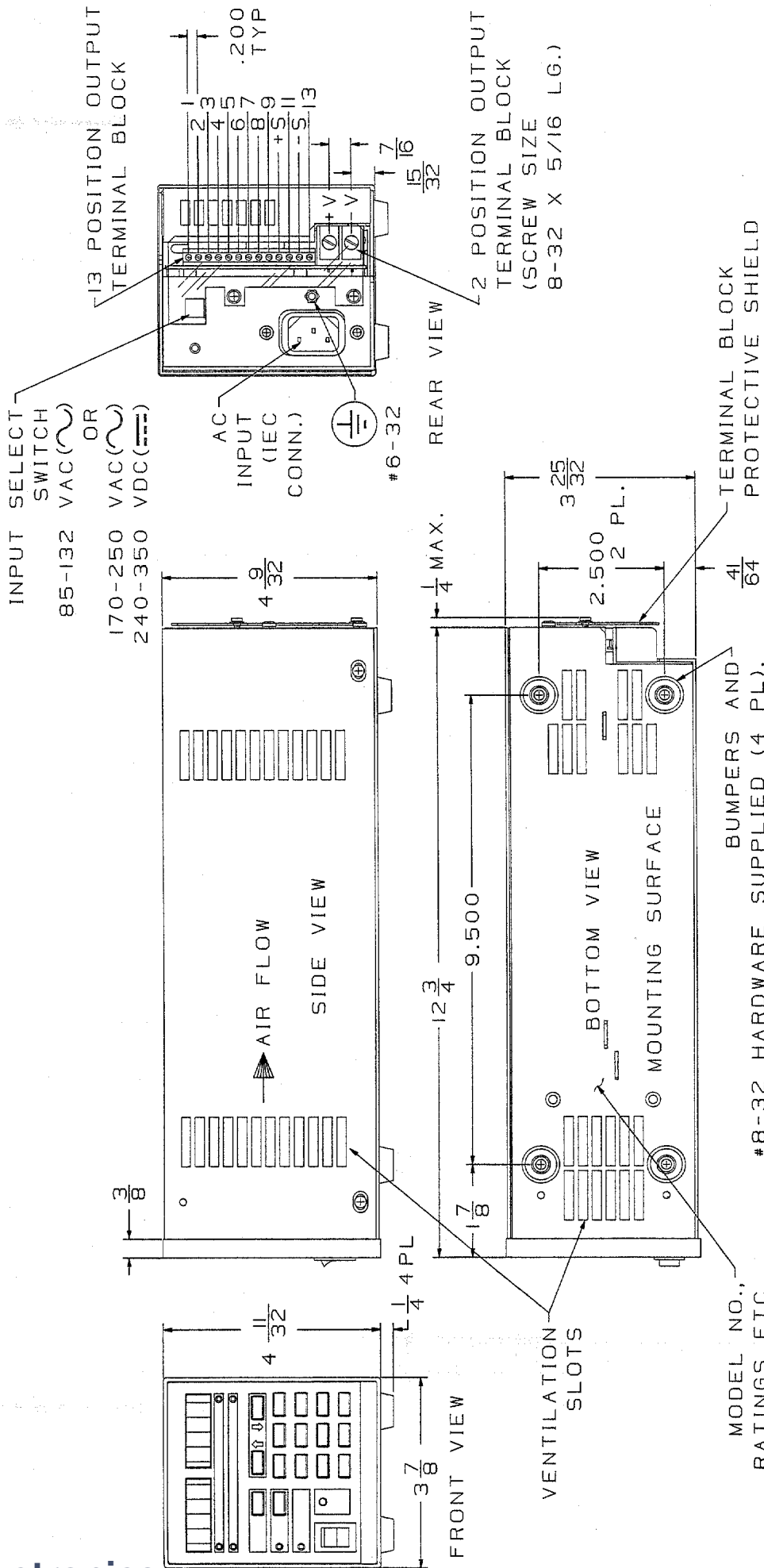

MODEL NO., RATINGS ETC. #8-32 HARDWARE SUPPLIED (4 PL). SCREENED ON THIS SURFACE. POWER SUPPLY BY MORE THAN 1/4 INCH.

Figure 17. Outline Drawing

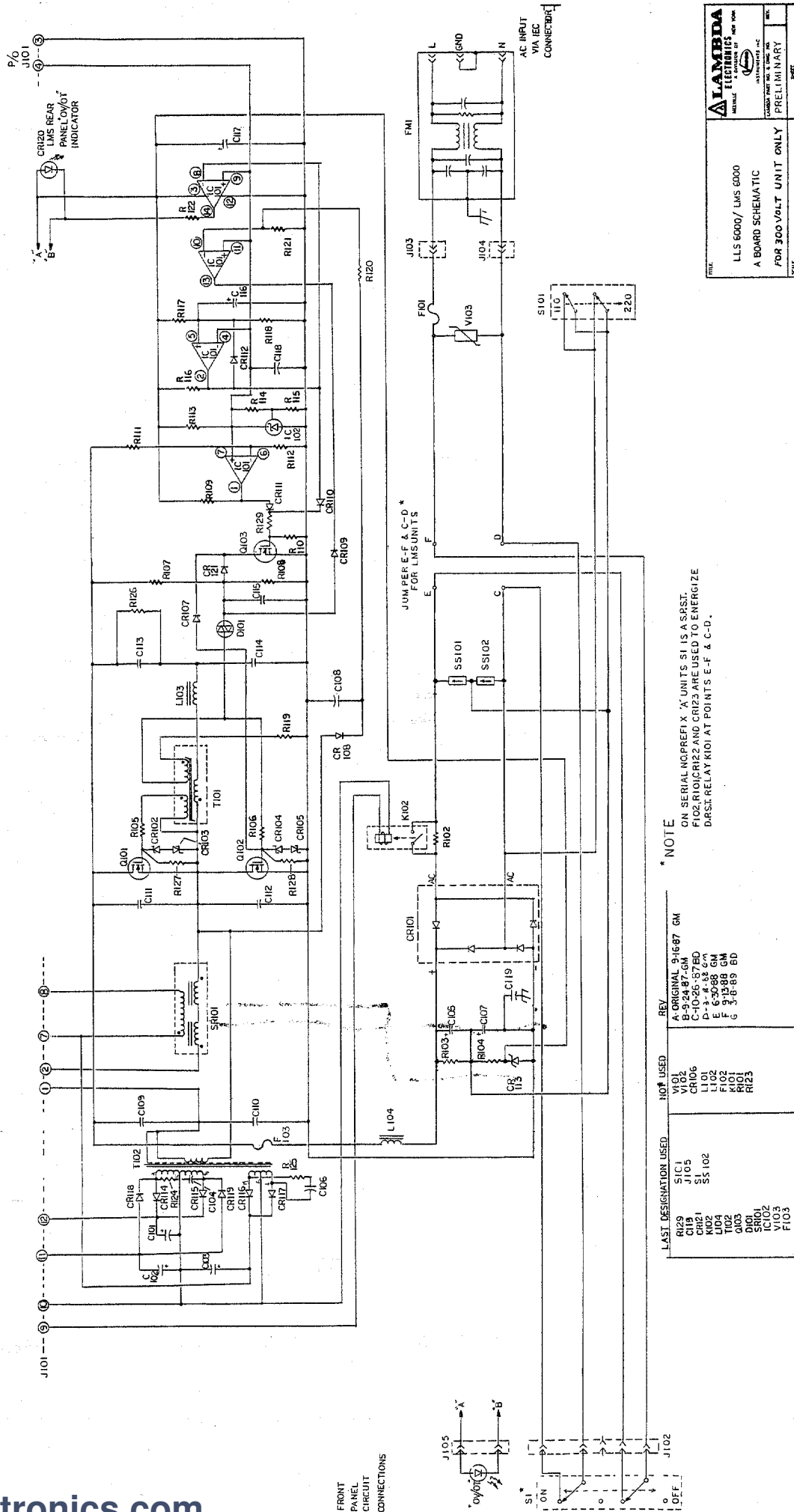

LAMBDA
 ELECTRONICS
 MANUFACTURING CO.

LLS 6000/ LMS 6000
 A BOARD SCHEMATIC
 FOR 300 Volt UNIT ONLY

LAMBDA PART NO. & DATE: _____
 PRELIMINARY
 SCALE: _____
 SHEET: _____

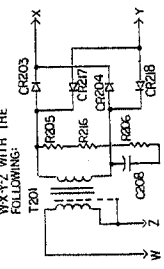
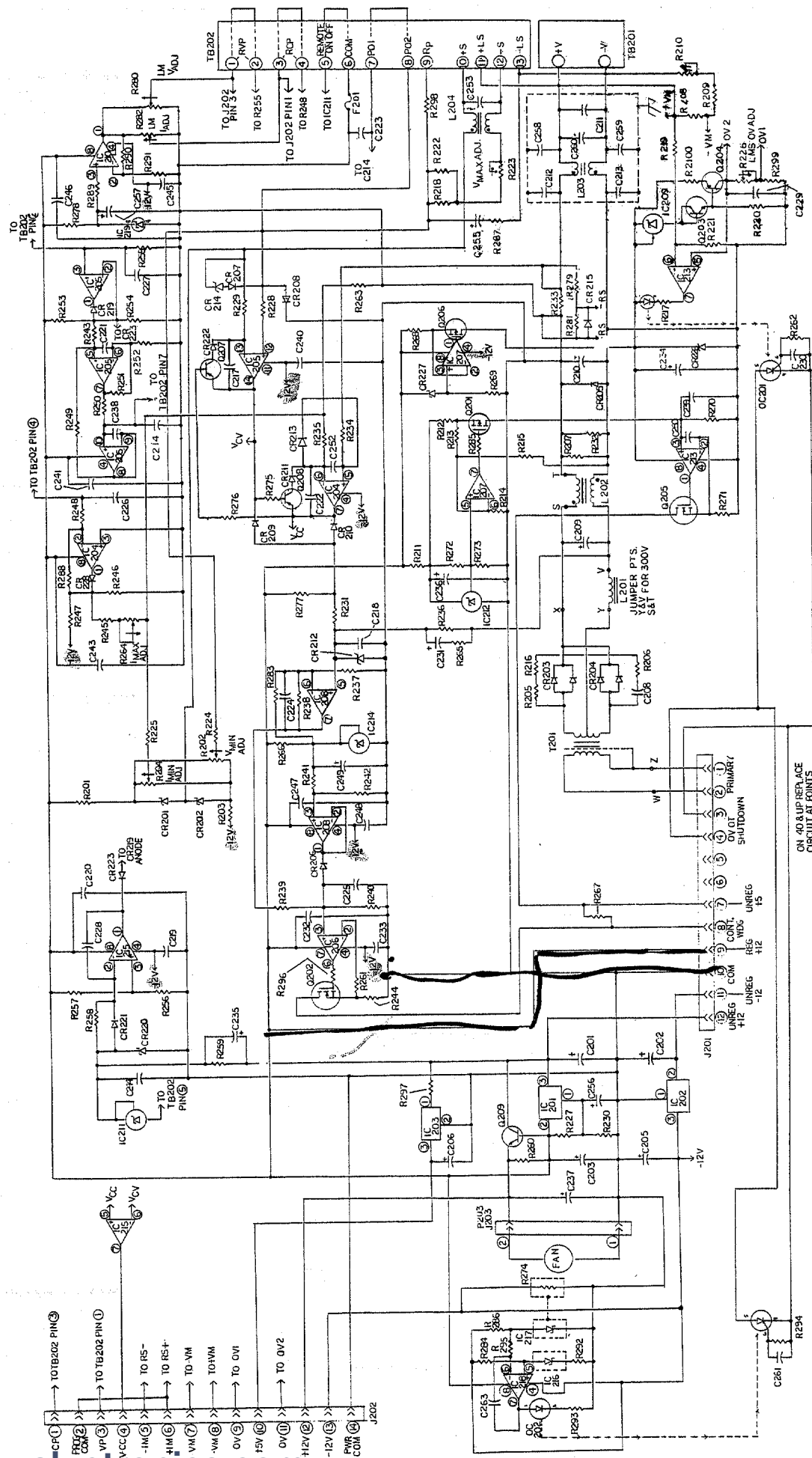

| LAST DES USED | NOT USED | REV |
|---------------|-------------|-----------|
| IC201 | 3 2A 88 G14 | A REDRAWN |
| IC202 | 3 2A 88 G14 | B |
| IC203 | 4 14 88 G14 | C |
| IC204 | 4 14 88 G14 | D |
| IC205 | 5 14 88 G14 | E |
| IC206 | 5 14 88 G14 | F |
| IC207 | 5 14 88 G14 | G |
| IC208 | 5 14 88 G14 | |
| IC209 | 5 14 88 G14 | |
| IC210 | 5 14 88 G14 | |
| IC211 | 5 14 88 G14 | |
| IC212 | 5 14 88 G14 | |
| IC213 | 5 14 88 G14 | |
| IC214 | 5 14 88 G14 | |
| IC215 | 5 14 88 G14 | |
| IC216 | 5 14 88 G14 | |
| IC217 | 5 14 88 G14 | |
| IC218 | 5 14 88 G14 | |
| IC219 | 5 14 88 G14 | |
| IC220 | 5 14 88 G14 | |
| IC221 | 5 14 88 G14 | |
| IC222 | 5 14 88 G14 | |
| IC223 | 5 14 88 G14 | |
| IC224 | 5 14 88 G14 | |
| IC225 | 5 14 88 G14 | |
| IC226 | 5 14 88 G14 | |
| IC227 | 5 14 88 G14 | |
| IC228 | 5 14 88 G14 | |
| IC229 | 5 14 88 G14 | |
| IC230 | 5 14 88 G14 | |
| IC231 | 5 14 88 G14 | |
| IC232 | 5 14 88 G14 | |
| IC233 | 5 14 88 G14 | |
| IC234 | 5 14 88 G14 | |
| IC235 | 5 14 88 G14 | |
| IC236 | 5 14 88 G14 | |
| IC237 | 5 14 88 G14 | |
| IC238 | 5 14 88 G14 | |
| IC239 | 5 14 88 G14 | |
| IC240 | 5 14 88 G14 | |
| IC241 | 5 14 88 G14 | |
| IC242 | 5 14 88 G14 | |
| IC243 | 5 14 88 G14 | |
| IC244 | 5 14 88 G14 | |
| IC245 | 5 14 88 G14 | |
| IC246 | 5 14 88 G14 | |
| IC247 | 5 14 88 G14 | |
| IC248 | 5 14 88 G14 | |
| IC249 | 5 14 88 G14 | |
| IC250 | 5 14 88 G14 | |
| IC251 | 5 14 88 G14 | |
| IC252 | 5 14 88 G14 | |
| IC253 | 5 14 88 G14 | |
| IC254 | 5 14 88 G14 | |
| IC255 | 5 14 88 G14 | |
| IC256 | 5 14 88 G14 | |
| IC257 | 5 14 88 G14 | |
| IC258 | 5 14 88 G14 | |
| IC259 | 5 14 88 G14 | |
| IC260 | 5 14 88 G14 | |
| IC261 | 5 14 88 G14 | |
| IC262 | 5 14 88 G14 | |
| IC263 | 5 14 88 G14 | |
| IC264 | 5 14 88 G14 | |
| IC265 | 5 14 88 G14 | |
| IC266 | 5 14 88 G14 | |
| IC267 | 5 14 88 G14 | |
| IC268 | 5 14 88 G14 | |
| IC269 | 5 14 88 G14 | |
| IC270 | 5 14 88 G14 | |
| IC271 | 5 14 88 G14 | |
| IC272 | 5 14 88 G14 | |
| IC273 | 5 14 88 G14 | |
| IC274 | 5 14 88 G14 | |
| IC275 | 5 14 88 G14 | |
| IC276 | 5 14 88 G14 | |
| IC277 | 5 14 88 G14 | |
| IC278 | 5 14 88 G14 | |
| IC279 | 5 14 88 G14 | |
| IC280 | 5 14 88 G14 | |
| IC281 | 5 14 88 G14 | |
| IC282 | 5 14 88 G14 | |
| IC283 | 5 14 88 G14 | |
| IC284 | 5 14 88 G14 | |
| IC285 | 5 14 88 G14 | |
| IC286 | 5 14 88 G14 | |
| IC287 | 5 14 88 G14 | |
| IC288 | 5 14 88 G14 | |
| IC289 | 5 14 88 G14 | |
| IC290 | 5 14 88 G14 | |
| IC291 | 5 14 88 G14 | |
| IC292 | 5 14 88 G14 | |
| IC293 | 5 14 88 G14 | |
| IC294 | 5 14 88 G14 | |
| IC295 | 5 14 88 G14 | |
| IC296 | 5 14 88 G14 | |
| IC297 | 5 14 88 G14 | |
| IC298 | 5 14 88 G14 | |
| IC299 | 5 14 88 G14 | |

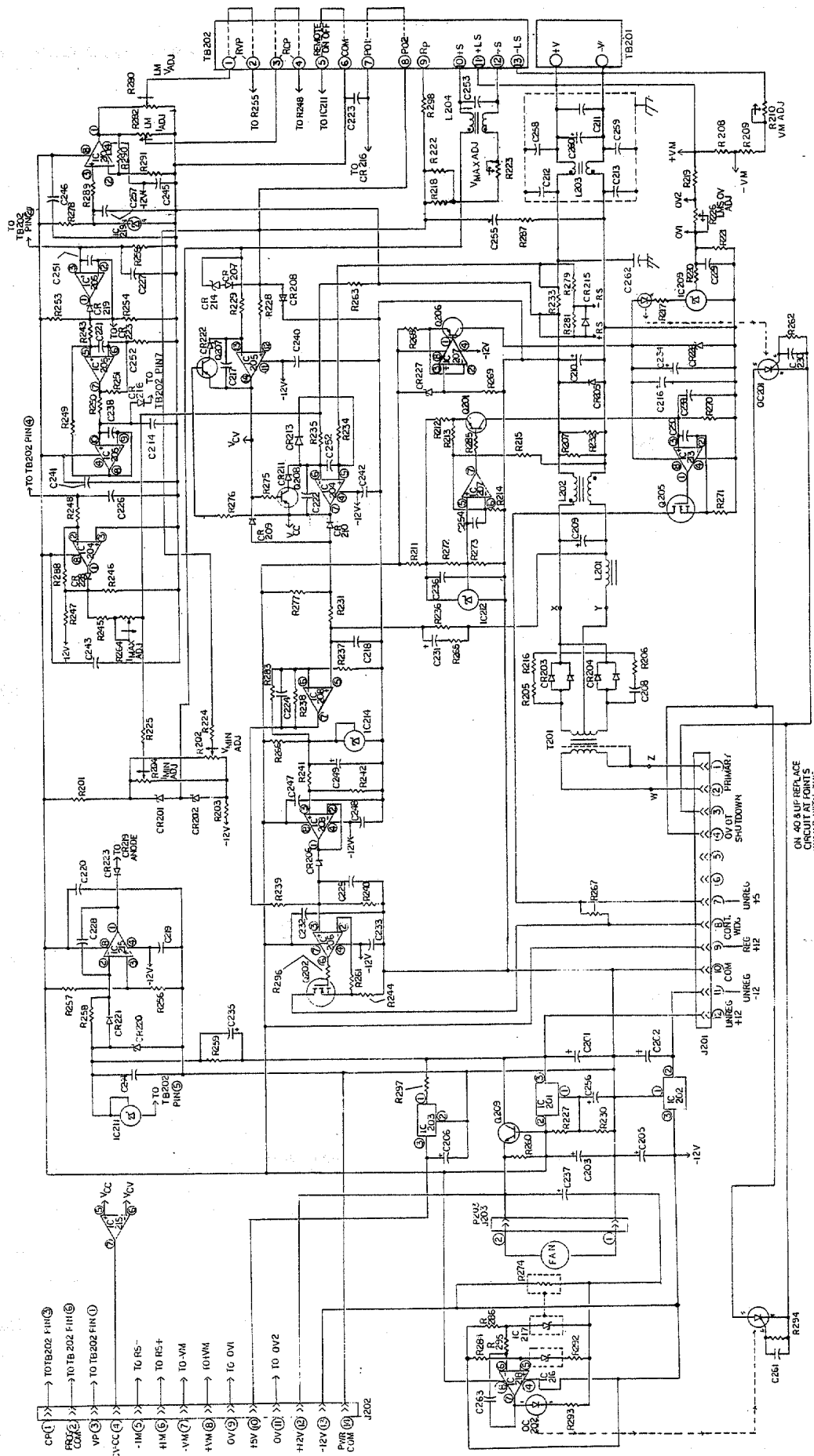

- CF1 (1) >> TO TB202 PIN 3
- CF2 (2) >> TO TB 202 PIN 6
- CF3 (3) >> TO TB202 PIN 1
- CF4 (4) >> TO TB202 PIN 1
- CF5 (5) >> TO TB202 PIN 1
- CF6 (6) >> TO TB202 PIN 1
- CF7 (7) >> TO TB202 PIN 1
- CF8 (8) >> TO TB202 PIN 1
- CF9 (9) >> TO TB202 PIN 1
- CF10 (10) >> TO TB202 PIN 1
- CF11 (11) >> TO TB202 PIN 1
- CF12 (12) >> TO TB202 PIN 1
- CF13 (13) >> TO TB202 PIN 1
- CF14 (14) >> TO TB202 PIN 1
- CF15 (15) >> TO TB202 PIN 1
- CF16 (16) >> TO TB202 PIN 1
- CF17 (17) >> TO TB202 PIN 1
- CF18 (18) >> TO TB202 PIN 1
- CF19 (19) >> TO TB202 PIN 1
- CF20 (20) >> TO TB202 PIN 1
- CF21 (21) >> TO TB202 PIN 1
- CF22 (22) >> TO TB202 PIN 1
- CF23 (23) >> TO TB202 PIN 1
- CF24 (24) >> TO TB202 PIN 1
- CF25 (25) >> TO TB202 PIN 1
- CF26 (26) >> TO TB202 PIN 1
- CF27 (27) >> TO TB202 PIN 1
- CF28 (28) >> TO TB202 PIN 1
- CF29 (29) >> TO TB202 PIN 1
- CF30 (30) >> TO TB202 PIN 1
- CF31 (31) >> TO TB202 PIN 1
- CF32 (32) >> TO TB202 PIN 1
- CF33 (33) >> TO TB202 PIN 1
- CF34 (34) >> TO TB202 PIN 1
- CF35 (35) >> TO TB202 PIN 1
- CF36 (36) >> TO TB202 PIN 1
- CF37 (37) >> TO TB202 PIN 1
- CF38 (38) >> TO TB202 PIN 1
- CF39 (39) >> TO TB202 PIN 1
- CF40 (40) >> TO TB202 PIN 1
- CF41 (41) >> TO TB202 PIN 1
- CF42 (42) >> TO TB202 PIN 1
- CF43 (43) >> TO TB202 PIN 1
- CF44 (44) >> TO TB202 PIN 1
- CF45 (45) >> TO TB202 PIN 1
- CF46 (46) >> TO TB202 PIN 1
- CF47 (47) >> TO TB202 PIN 1
- CF48 (48) >> TO TB202 PIN 1
- CF49 (49) >> TO TB202 PIN 1
- CF50 (50) >> TO TB202 PIN 1
- CF51 (51) >> TO TB202 PIN 1
- CF52 (52) >> TO TB202 PIN 1
- CF53 (53) >> TO TB202 PIN 1
- CF54 (54) >> TO TB202 PIN 1
- CF55 (55) >> TO TB202 PIN 1
- CF56 (56) >> TO TB202 PIN 1
- CF57 (57) >> TO TB202 PIN 1
- CF58 (58) >> TO TB202 PIN 1
- CF59 (59) >> TO TB202 PIN 1
- CF60 (60) >> TO TB202 PIN 1
- CF61 (61) >> TO TB202 PIN 1
- CF62 (62) >> TO TB202 PIN 1
- CF63 (63) >> TO TB202 PIN 1
- CF64 (64) >> TO TB202 PIN 1
- CF65 (65) >> TO TB202 PIN 1
- CF66 (66) >> TO TB202 PIN 1
- CF67 (67) >> TO TB202 PIN 1
- CF68 (68) >> TO TB202 PIN 1
- CF69 (69) >> TO TB202 PIN 1
- CF70 (70) >> TO TB202 PIN 1
- CF71 (71) >> TO TB202 PIN 1
- CF72 (72) >> TO TB202 PIN 1
- CF73 (73) >> TO TB202 PIN 1
- CF74 (74) >> TO TB202 PIN 1
- CF75 (75) >> TO TB202 PIN 1
- CF76 (76) >> TO TB202 PIN 1
- CF77 (77) >> TO TB202 PIN 1
- CF78 (78) >> TO TB202 PIN 1
- CF79 (79) >> TO TB202 PIN 1
- CF80 (80) >> TO TB202 PIN 1
- CF81 (81) >> TO TB202 PIN 1
- CF82 (82) >> TO TB202 PIN 1
- CF83 (83) >> TO TB202 PIN 1
- CF84 (84) >> TO TB202 PIN 1
- CF85 (85) >> TO TB202 PIN 1
- CF86 (86) >> TO TB202 PIN 1
- CF87 (87) >> TO TB202 PIN 1
- CF88 (88) >> TO TB202 PIN 1
- CF89 (89) >> TO TB202 PIN 1
- CF90 (90) >> TO TB202 PIN 1
- CF91 (91) >> TO TB202 PIN 1
- CF92 (92) >> TO TB202 PIN 1
- CF93 (93) >> TO TB202 PIN 1
- CF94 (94) >> TO TB202 PIN 1
- CF95 (95) >> TO TB202 PIN 1
- CF96 (96) >> TO TB202 PIN 1
- CF97 (97) >> TO TB202 PIN 1
- CF98 (98) >> TO TB202 PIN 1
- CF99 (99) >> TO TB202 PIN 1
- CF100 (100) >> TO TB202 PIN 1

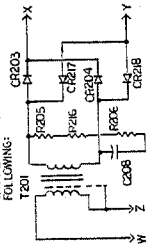

LAMBDA
ELECTRONICS

FC BOARD B
SCHEMATIC DIAGRAM

LLS/LMS 6000

PRELIMINARY

FRONT
PANEL
CIRCUIT
CONNECTIONS

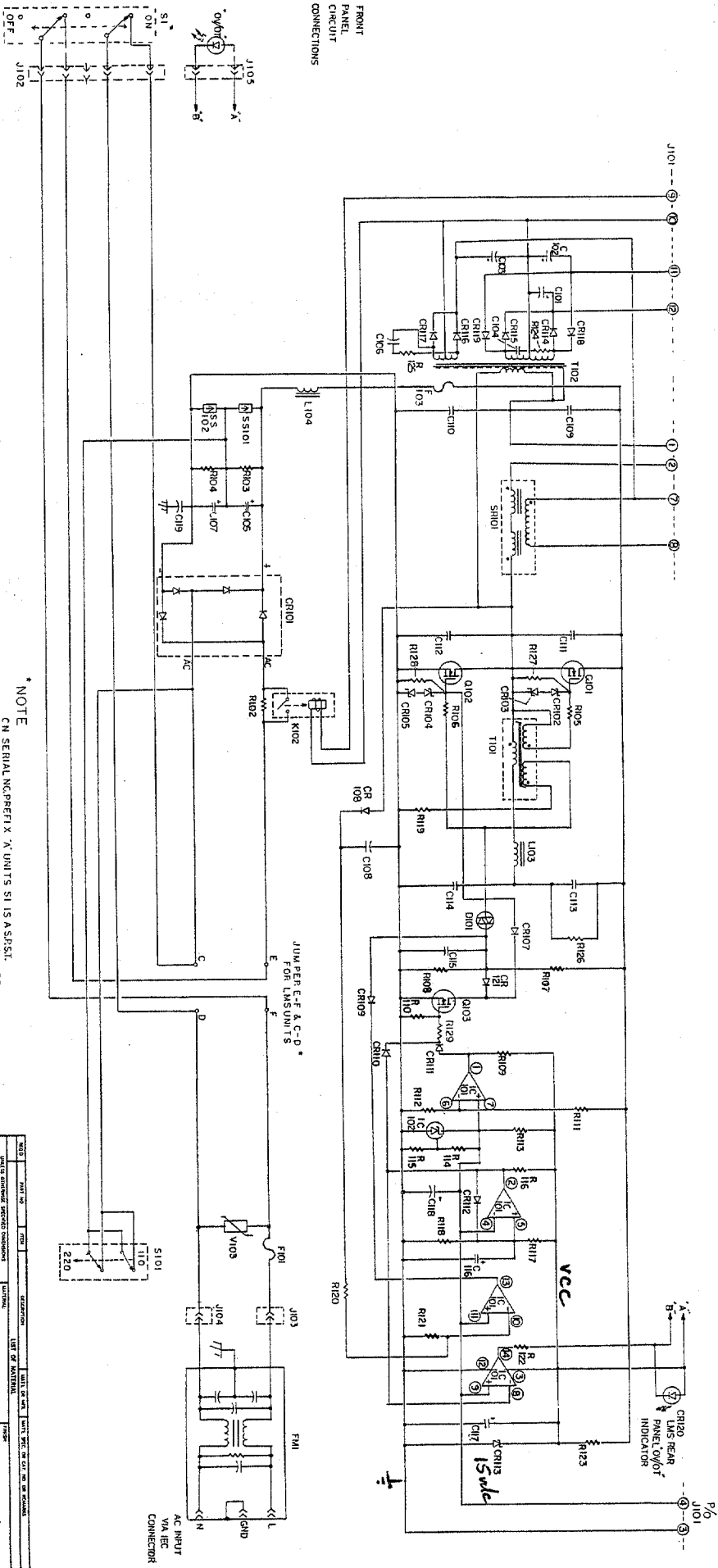

NOTE
CN SERIAL NO. PREFIX 'X' UNITS S115-A, S1P8-
F102, H102, R122 AND CR123 ARE USED TO C-ENERGIZE.
DASH RELAY (K101) AT POINTS A-B & C-E.

| REV | DATE | BY | DESCRIPTION | LIST OF MATERIAL | TRIALS |
|-----|------|----|-------------------------|------------------|--------|
| 1 | | | INITIAL DESIGN | | |
| 2 | | | REVISED TO MATCH S115-A | | |
| 3 | | | REVISED TO MATCH S115-B | | |
| 4 | | | REVISED TO MATCH S115-C | | |
| 5 | | | REVISED TO MATCH S115-D | | |
| 6 | | | REVISED TO MATCH S115-E | | |
| 7 | | | REVISED TO MATCH S115-F | | |
| 8 | | | REVISED TO MATCH S115-G | | |
| 9 | | | REVISED TO MATCH S115-H | | |
| 10 | | | REVISED TO MATCH S115-I | | |
| 11 | | | REVISED TO MATCH S115-J | | |
| 12 | | | REVISED TO MATCH S115-K | | |
| 13 | | | REVISED TO MATCH S115-L | | |
| 14 | | | REVISED TO MATCH S115-M | | |
| 15 | | | REVISED TO MATCH S115-N | | |
| 16 | | | REVISED TO MATCH S115-O | | |
| 17 | | | REVISED TO MATCH S115-P | | |
| 18 | | | REVISED TO MATCH S115-Q | | |
| 19 | | | REVISED TO MATCH S115-R | | |
| 20 | | | REVISED TO MATCH S115-S | | |
| 21 | | | REVISED TO MATCH S115-T | | |
| 22 | | | REVISED TO MATCH S115-U | | |
| 23 | | | REVISED TO MATCH S115-V | | |
| 24 | | | REVISED TO MATCH S115-W | | |
| 25 | | | REVISED TO MATCH S115-X | | |
| 26 | | | REVISED TO MATCH S115-Y | | |
| 27 | | | REVISED TO MATCH S115-Z | | |