

3Hz TO 5MHz
DIGITAL PHASEMETER
MODEL 6500A SERIAL NO. _____

OPERATING AND MAINTENANCE
MANUAL



KROHN-HITE CORPORATION
AVON INDUSTRIAL PARK/BODWELL STREET/AVON, MASS. 02322 USA

PRINTED IN USA - APRIL 1983

CONTENTS

Section		Page
1	GENERAL DESCRIPTION	1
2	OPERATION	7
3	INCOMING INSPECTION AND CHECKOUT	12
4	CIRCUIT DESCRIPTION	15
5	MAINTENANCE	22
6	CALIBRATION	26

ILLUSTRATIONS

Figure		Page
1	Model 6500 Phasemeter	ii
2	Maximum Phase Error vs % Harmonic Distortion	4
3	Phase Error vs. Random Noise	5
4	Typical Performance Curve	5
5	Operating Controls, Displays and Connectors	6
6	Simplified Block Diagram	15
7	Attenuator and Fet Input Amplifier	16
8	Incorrect Amplifier Detector	17
9	Switched Filter and Hot Carrier Limiter	17
10	Linear Amplifier	18
11	Comparator	19
12	Symmetry Correction Loop	19
13	Flip Flop	20
14	Differential Amplifier and Meter Network	20
15	Power Supplies	21
16	Test Points and Adjustable Components	26
17	Phase vs. Amplitude, Input A, Test Set-up	29
18	Phase vs. Amplitude, Input B, Test Set-up	29
19	Attenuator Impedance Adjustment Test Set-up	31

TABLE

Table		Page
1	Optional BCD Output Pin Connections	10

APPENDIX		Inside
Schematic, Component Diagrams, Parts List		Back Cover

Model 6500 Phasemeter

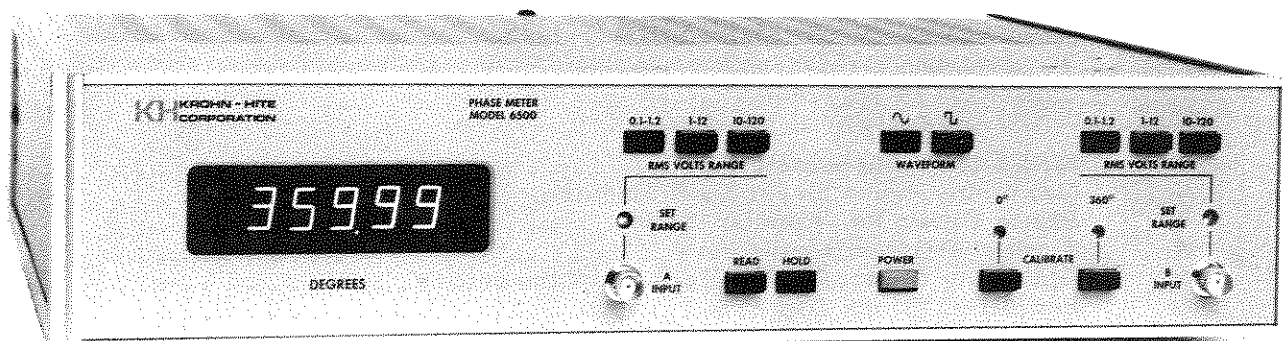

Figure 1. Model 6500 Phasemeter

SECTION 1

GENERAL DESCRIPTION

1.1 INTRODUCTION

The Krohn-Hite Model 6500 Phasemeter measures the phase angle between two waveforms of coincident frequency, over a range of 3 Hz to 5 MHz, and provides a typical accuracy of 0.02° , with 0.01° resolution. A 5 digit planar gas discharge display provides direct readout of the phase angle from 000.00° to 360.00° . The 6500 accepts input voltages from 0.01 volts RMS to 120 volts RMS. The fluctuations or inconsistencies normally encountered in phase angle readings near zero and 360° (sometimes referred to as ambiguity) are eliminated by a unique network in the 6500 that permits readings as small as 0.01° to be observed, without the need of changing ranges or 180° shifting. In addition, the circuitry of the 6500 significantly reduces the effects of distortion and noise on phase accuracy. An analog output on the rear panel provides a DC voltage equal to -10 mv/degree phase, for use with an external meter or recorder. An optional BCD output is also available. A read/hold switch also provides continuous display of the phase angle reading, or holding of the reading for an indefinite period.

An optional rack-mounting kit (Part No. RK-319) is available from Krohn-Hite, for installing the Model 6500 in a standard 19" rack-spacing.

The phasemeter is carefully inspected, aged, and adjusted before shipment, and should be ready for operation when it is unpacked. If it appears to have been damaged in shipment, make a claim with the carrier, and notify Krohn-Hite immediately.

1.2 SPECIFICATIONS

Frequency Range

3 Hz to 5 MHz

Accuracy

(For typical performance, refer to Figure 4)

Sinewave: $\pm 0.1^\circ \pm 1$ digit from 20Hz to 50kHz, rising to $\pm 0.7^\circ$ at 100kHz; $\pm 0.2^\circ$ at 10Hz; for any amplitude within the selected voltage range. Above 100kHz, $\pm 0.7^\circ$ per 100kHz, with equal amplitude and the same voltage range on each input.

Squarewave: $\pm 0.1^\circ \pm 1$ digit from 10Hz to 20Hz, rising to $\pm 0.7^\circ$ at 100kHz; for any amplitude within the selected voltage range. Above 100kHz, $\pm 0.7^\circ$ per 100kHz, with equal amplitude and the same voltage range on each input.

Model 6500 Phasemeter

Input Signal Amplitude

0.01 volts RMS to 120 volts RMS in three ranges: 0.1-1.2, 1-12 and 10-120. For higher input voltages, the use of matched attenuator probes, such as Tektronix types P6006, P6007, P6013A, P6049A, or P6060 is recommended.

(For input levels between 0.01 volts and 0.1 volts RMS, the 0.1-1.2 volt range is used; refer to Figure 4 for typical performance).

Input Waveforms

Sine, triangle, square and positive pulse waveforms.

(The phasemeter is triggered on the negative-going transition of the input waveform in both sine and square wave positions of the WAVEFORM switch.)

Input Impedance

1 Megohm in parallel with 50 pf.

Maximum DC Component

±200 volts (for higher voltages, the use of matched, attenuator probes, such as Tektronix types P6006, P6007, P6013A, P6049A, or P6060 is recommended).

Response

Time constant: Less than 500 msec.

Settling Time: To within specified accuracy, within one to eight seconds, dependent upon input signal amplitude.

Display

0.55 inch, 7-segment, planar gas discharge

Display Range

Continuous, 000.00° to 360.00°

Resolution

0.01°

Repeatability

Better than ±1 digit

Drift

None

VS TIME (30 days without CAL reset):

Sine Wave: ±0.025° from 20 Hz to 100 kHz; ±0.1° at 10 Hz; ±0.35° per 100 kHz above 100 kHz.

Square Wave: ±0.025° from 10 Hz to 5 kHz; ±0.05° to 100 kHz; ±0.35° per 100 kHz above 100 kHz.

Analog Output: ± 0.1 mv ($\pm 0.01^\circ$)

VS TEMPERATURE (without CAL reset):

$\pm 0.01^\circ/\text{C}$, 10 Hz to 100 kHz; $\pm 0.05^\circ/\text{C}$ to 1 MHz; $\pm 0.05^\circ/\text{C}$ per MHz about 1 MHz.

Ambient Temperature Range

0°C to 45°C

Analog Output

(For use with an external meter or recorder): 0 to -3.6 volts DC, -10 mv DC/degree phase, impedance 250 ohms.

BCD Output (Optional)

Provides 18 lines of phase angle equivalent BCD output, plus polarity, data ready, read/hold and read rate control lines. Compatible with DTL, TTL logic.

Programming connector AMP type 200277-2 rear panel mounted; mating connector (AMP type 200276-2), is provided.

Panel Controls and Adjustments

Front Panel: 3 decade push-button RMS VOLTS RANGE control (each channel), plus push-button READ/HOLD, WAVEFORM, POWER, 0° CAL and 360° CAL.

Rear Panel: 115/230V LINE, CHASSIS/FLOATING.

Terminals

Front Panel: BNC for A input, B input.

Rear Panel: BNC for A input, B input, analog output, AMP type 200277-2 for BCD output (optional).

Power Requirements

105-125 volts, or 210-250 volts, single phase, 50-60 Hz, 40 watts.

Dimensions and Weights

Model 6500: 16-1/2" wide, 3-1/2" high, 16" deep, 15 lbs/6.8 Kgs net, 18 lbs/8 Kgs shipping.

Optional Rack Mounting Kit

Part No. RK-319, permits installation of the 6500 into a standard 19" rack spacing.



1.3 FACTORS AFFECTING PHASEMETER ACCURACY

1.3.1 Inconsistencies in Meter Readings Near 0° and 360°

A problem affecting a phasemeter's accuracy is the inability of the phasemeter circuit to detect relatively small phase angles, resulting in meter fluctuations or inconsistencies in readings. The 6500 overcomes this inconsistency (or ambiguity as it is sometime referred to) by using a specially designed network that permits measurements as small as 0.01° to be made without meter fluctuations or repeatability errors, and eliminates the need for multiple meter ranges, or shifting of the meter scale.

1.3.2 Distortion Present on the Input Signal

If there is distortion present on one of the signals, a phase error may be introduced, depending on the relationship between the fundamental and its harmonics. If the amplitudes of all odd or even harmonics add up to zero at the negative zero crossing of the fundamental, then the harmonics will produce no phase error. If the resultant of the amplitudes is not zero, however, it will cause a shift in the zero crossing of the input waveform. (Worst case would occur when the maximum of the harmonic coincides with the negative zero crossing of the fundamental.) The effect of an even harmonic will not only shift the zero crossing of the waveform, but also alter the symmetry of the comparator or detector output. If a symmetry control loop is added to the phasemeter circuit, the effect of the even harmonic on accuracy can be minimized. The 6500 uses the type of symmetry loop mentioned above.

The effect of an odd order harmonic, however, is not as easily corrected. An odd order harmonic simply shifts the phase of the output of the comparator or detector loop. Since the symmetry is not affected there is no way to detect any phase error.

Figure 2 shows the maximum phase error introduced versus the percentage of harmonic distortion present on each input channel.

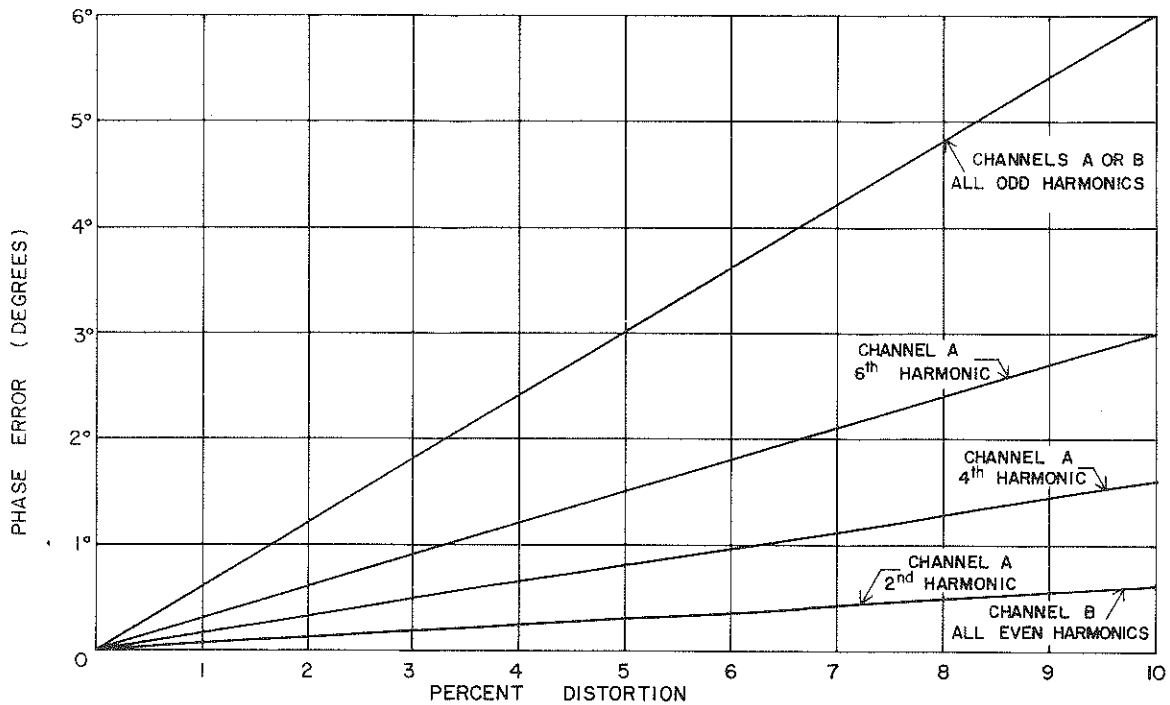

Figure 2. Maximum Phase Error vs % Harmonic Distortion (Worst case would occur when the maximum of the harmonic coincides with the negative zero crossing of the fundamental.)

1.3.3 Noise Present on the Input Signals

Another problem affecting phase accuracy is random noise. If there is a sufficient noise level on either input (or both), false triggering will occur and a phase error is introduced. The 6500 uses special circuits plus filtering to minimize the effects of noise on the phase accuracy. Typically, any broadband noise present on both inputs 40 db down from the input signals will produce only a 0.05° error. Figure 3 gives a typical curve for phase error versus input frequency, for a signal to noise ratio of 10:1 on both inputs.

1.3.4 Typical Performance

The typical performance of the Model 6500 is illustrated in Figure 4.

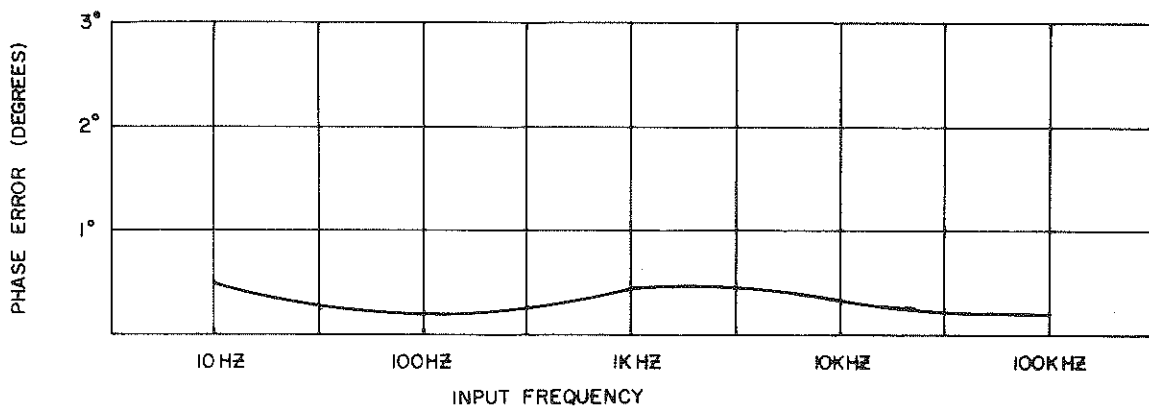

Figure 3. Phase Error vs. Random Noise

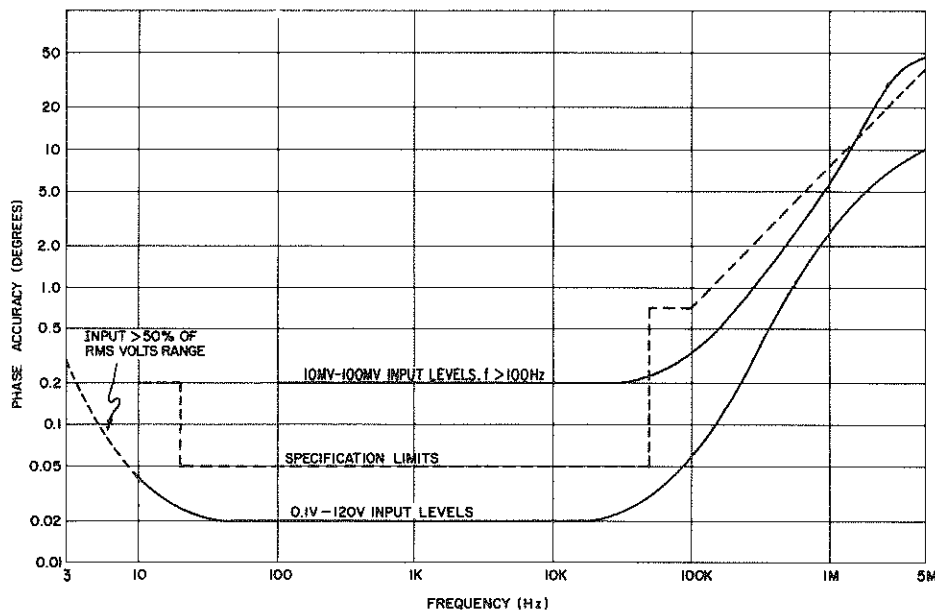
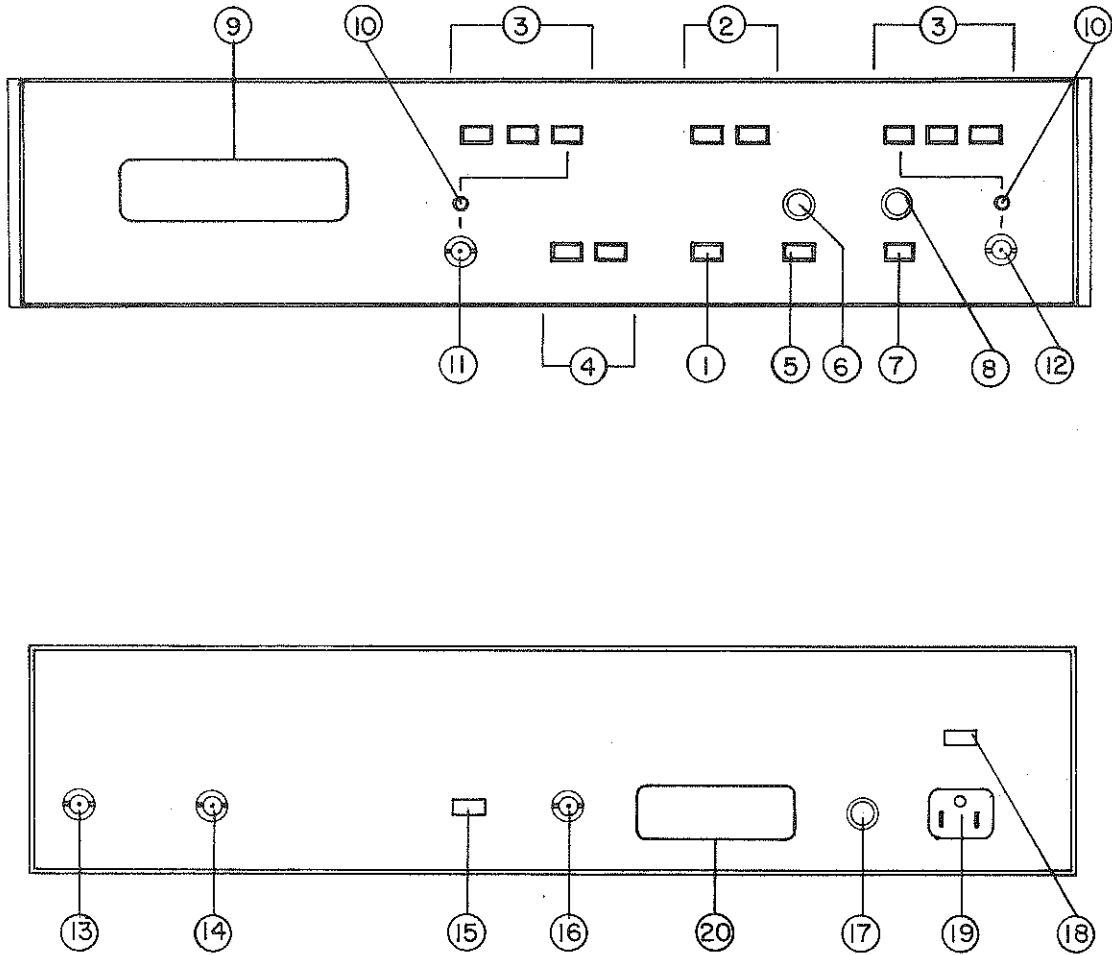

Figure 4. Typical Performance



- | | |
|-------------------------------|---|
| ① POWER SWITCH | ⑪ CHANNEL A INPUT (BNC) |
| ② WAVEFORM SWITCHES | ⑫ CHANNEL B INPUT (BNC) |
| ③ RMS VOLTS RANGE SWITCHES | ⑬ CHANNEL B REAR INPUT (BNC) |
| ④ READ/HOLD SWITCHES | ⑭ ANALOG DC OUTPUT |
| ⑤ 0° CAL SWITCH | ⑮ GROUND SWITCH (CHASSIS/FLOATING) |
| ⑥ 0° CAL SCREWDRIVER ADJUST | ⑯ CHANNEL A REAR INPUT (BNC) |
| ⑦ 360° CAL SWITCH | ⑰ FUSE |
| ⑧ 360° CAL SCREWDRIVER ADJUST | ⑱ LINE SWITCH |
| ⑨ DIGITAL PANEL METER | ⑲ POWER RECEPTACLE |
| ⑩ SET RANGE INDICATORS | ⑳ BCD OUTPUT (OPTIONAL;
AMP TYPE 200277-2) |

Figure 5. Operating Controls, Displays and Connectors

SECTION 2

OPERATION



2.1 POWER REQUIREMENTS

The Model 6500 Phasemeter may be used with either a 105 - 125 volt, 50 - 400 Hz line or a 210-250 volt 50 - 400 Hz line. The line voltage can be selected by operation of the LINE switch on the rear panel. When the line voltage is 115 volts, a 0.5 ampere fuse is required; when the line voltage is 220 volts, a 0.25 ampere fuse should be used.

2.2 OPERATING CONTROLS, DISPLAYS AND CONNECTORS (See figure 5)

2.2.1 Front Panel Controls

POWER: On-off pushbutton switch.

WAVEFORM: Two-position push button switch selects sine wave or square wave mode of operation. When sine or triangle waveforms are used as input signals, the WAVEFORM switch should be set for ; when square waves or positive pulses are used, the WAVEFORM switch is set to the  mode.

RMS VOLTS RANGE: Three position push button switch (each channel) for selecting input voltage ranges from 0.01 volts RMS to 120 volts RMS. For input levels between 0.01 volts and 0.1 volts RMS, the 0.1-1.2 volt range is used. (Refer to Figure 4, Page 5 for typical performance.) The voltage ranges are 0.1-1.2, 1-12 and 10-120. The voltage range may be extended using Tektronix matched probes. (Types P6006, P6007, P6013A, P6049A, or P6060.)

READ/HOLD: Two - position push button switch. In the READ mode, the phase angle being measured is continuously displayed on the readout. In the HOLD mode, the last reading is held for an indefinite period.

0° CAL: Push-button hold-release switch for checking 0° calibration. A front panel screwdriver control is also provided for adjustment of zero scale.

360° CAL: Push-button hold-release switch for checking 360° (full scale) calibration. A front panel screwdriver control is also provided for adjustment of full scale.

2.2.2 Rear Panel Controls

LINE: Two-position slide switch for selecting 115 or 230 volt operation.

CHASSIS/FLOATING: Two-position slide switch for selecting chassis or floating ground. In the FLOATING mode, signal ground is isolated from chassis ground.

2.2.3 Displays

5 digit planar gas discharge displays the phase angle being measured, in degrees, from 000.00° to 360.00° .

SET RANGE: Front panel LED indicator, (one for each channel) illuminates when the input voltage for that particular channel is either above or below the selected range.

2.2.4 Connectors

Front panel: BNC connector for each channel input.

Rear panel: BNC connector for each channel input. ANALOG OUTPUT, BNC, equal to -10 mv/degree phase, for use with external meter or recorder. BCD OUTPUT (optional), AMP type 200277-2 connector. Power Receptacle for line cord.

2.3 OPERATION

To operate the 6500 phasemeter proceed as follows:

1. Make appropriate power connections (see Section 2.1).
2. Push the POWER switch to the ON (recessed) position, and allow the unit to warm up for at least 30 minutes to achieve rated accuracy.
3. Set the READ/HOLD switch to the READ position.
4. Push the 0° CAL button. Adjust the 0° screwdriver control (if necessary) so that the meter reads 000.00° .
5. Push the 360° CAL button. Adjust the 360° screwdriver control (if necessary) so that the meter reads 360.00° .

After the unit has been allowed to warm up, connect the reference signal to the A input and the signal to be measured to the B input.

(It is recommended that matched, equal length, coaxial input cables be used, as a difference in length or cable capacitance may affect the phasemeter accuracy, particularly at high frequencies. As an example, consider two cables that are the same type (approximately 30 pf/foot) but of different length. A difference of one foot between the two cables will create an error at 100 KHz of about 0.06° .)

After connecting the cables to the two input channels, set the WAVEFORM switch to the desired mode. In the \sim mode, the phasemeter will measure phase angles between sine waves, a sine and triangle wave, or triangular waves. In the \square mode, square waves, a square wave and positive pulse, or positive pulses should be used. If a sine wave is used in the \square mode or vice-versa, an error of several degrees can be expected.

After selecting the proper WAVEFORM mode, set the VOLTS RMS RANGE buttons to a position where the LED indicator is extinguished. This will indicate that the input signal level is within the proper range. The 6500 will now display the phase angle, in degrees, between the two input signals. Refer to Section 1 for the appropriate accuracy specifications.

For phase angle readings passing through 360.00° , the meter reading will remain at the 360.00° end until the reading is approximately 364.00° . At this point the meter reading will shift itself 360° to its corresponding low end, or 004.00° .

Conversely, if the meter reading passes through 000.00° , the meter reading will remain at the low end until about -004.00° , where it will then shift itself 360° to a new reading of 356.00° .

This feature allows readings to be taken at or near 0° or 360° without meter fluctuations.

It is also possible to shift the phase reading as follows (applicable to sine wave position of WAVEFORM switch, only):

If the meter is reading near 0° , and a reading near 360° is desired, simply depress the 360° CAL button for about 3 seconds, then release. If the meter reading is near 360° , and a reading near 0° is desired, simply depress the 0° CAL button for about 3 seconds, and then release.

When the input voltage level exceeds 120 volts RMS, or the DC component of the signal exceeds ± 200 volts, the input range of the 6500 can be extended with Tektronix or similar type matched probes. (Tektronix types P6006, P6007, P6013A, P6049A or P6060, or equivalent).

The probe should match an input resistance of 1 megohm and should be adjustable to match an input capacitance up to 50 pf. The broadbanding screw should be adjusted for 0° (or 360°) reading with a signal directly on one of the phasemeter inputs and the probe (on the other phase meter input) connected to the same signal. Reverse the procedure for a probe on the other phase meter input. For optimum accuracy, the probe(s) should be adjusted at each frequency used before making phase measurements. For less stringent accuracy requirements, the probe(s) need not be adjusted carefully.

If a 10 Megohm probe (or 10 Megohm source impedance) is used on one channel only, below 200 Hz, or a 1 Megohm source impedance below 20 Hz on one channel only, an appreciable error is introduced, because of the phasemeter input coupling capacitors. (10 Megohms will produce approximately 0.8° at 10 Hz). This error can be cancelled by adding an equivalent source impedance in series with the input to the other channel at these low frequencies. (If left in at higher frequencies, it must be accurately broadbanded with a shunt capacitance).

2.4 BCD OUTPUT (OPTIONAL)

A digital programming connector (AMP type 200277-2), is mounted on the rear panel, and provides an equivalent BCD output of the front-panel display, plus four additional data control lines. A total of 22 programming lines plus 3 lines of the programming ground return are provided.

A total of 18 lines are used to provide the BCD equivalent output of the 5 digit, front panel display. Each digit, with the exception of the 100's digit, is represented by four output lines, and is binary-coded in a 1-2-4-8 format. The 100's digit is represented by two lines, coded in a 1-2 format.

The four additional data control lines provide the following functions:

1. POLARITY (OUTPUT): The output logic level of this line remains in a "High" state when the displayed phase angle is positive; output level will convert to a "Low" state if the phase angle display goes negative.

(Con't on Page 11)

Table 1.
 OPTIONAL BCD OUTPUT PIN CONNECTIONS
 (Using AMP type 200277-2 Connector)

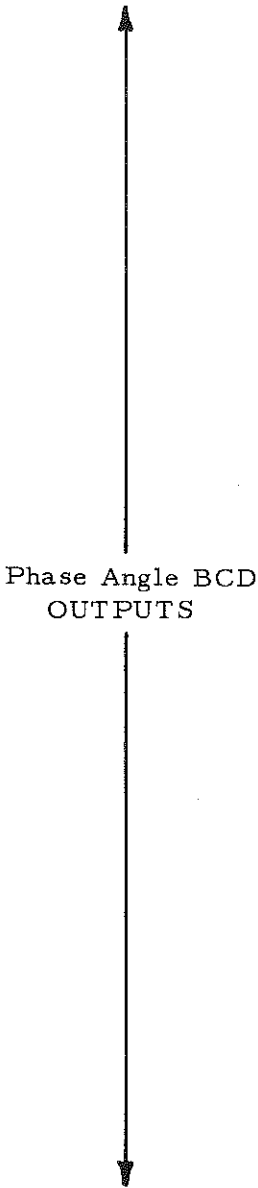
Pin Letter	Function	Description
A	000.01	 <p>Phase Angle BCD OUTPUTS</p>
B	000.02	
C	000.04	
D	000.08	
E	DIG. GND.	
F	000.10	
H	000.20	
J	000.40	
K	000.80	
L	DIG. GND.	
M	001.00	
N	002.00	
P	004.00	
R	008.00	
S	DIG. GND.	
T	010.00	
U	020.00	
V	040.00	
W	080.00	
X	100.00	
Y	200.00	
Z	Polarity (Output)	"High" for pos. angle "Low" for neg. angle
a	Conversion Complete (Output)	"High" for data ready "Low" for conversion
b	Transfer Inhibit (Input)	"Low" for data read "High" or open for data hold
c	Read Rate (Input)	"High" for 4 cts/sec "Low" for 20 cts/sec

2. CONVERSION COMPLETE (OUTPUT): The output logic level of this line will remain "Low" during the Digital Panel Meter's measurement or conversion cycle; the output will convert to a "High" state when conversion of data is completed.
3. TRANSFER INHIBIT (INPUT): This input is used in conjunction with the front panel READ/HOLD switch, and provides remote control of the READ/HOLD function. When the front panel READ/HOLD switch is in the READ mode, the TRANSFER INHIBIT control line is inoperative; when the switch is in the HOLD mode, a "Low" level applied to the TRANSFER INHIBIT input line will allow both the front panel display and the BCD outputs to be continuously updated by new data. A "High" level applied to the TRANSFER INHIBIT line will hold or maintain the last data displayed, plus the equivalent data on the BCD outputs.
4. READ RATE (INPUT): This input is provided for selection of the DPM's read/rate. A "High" level applied to the READ/RATE input will effect a DPM read/rate of 4 counts/second; a "Low" level will convert the read/rate to 20 counts/second.

The logic levels for all OUTPUT lines are as follows:

$$0V \leq \text{Low} \leq 0.5V; I_{\text{sink}} = 10\text{mA}$$

$$2.4V \leq \text{High} \leq 5.5V; R_{\text{source}} = 6K \text{ Ohm}$$

The logic levels for all INPUT lines are as follows:

$$0V \leq \text{Low} \leq 0.8V; I_{\text{sink}} = 1.6\text{mA}$$

$$2.0V \leq \text{High} \leq 5.0V; I_{\text{source}} = 0.1\text{mA}$$

A mating connector for the AMP type 200277-2 (Part No. AMP type 200276-2) is provided.

SECTION 3

INCOMING INSPECTION AND CHECKOUT

3.1 INTRODUCTION

The following procedure is used to verify that the phasemeter is operating within specifications, both for incoming inspection and for routine servicing. Tests should be made with all covers in place, and the procedure given below should be followed in sequence.

SPECIAL NOTE

As an alternate to the following procedure, a Primary Phase Angle Standard such as the Dytronic Model 311/RT-1/717S may be used for accuracy measurements between 30 Hz and 10 KHz. A second alternative is the use of a Computing Counter System such as the Hewlett Packard Model 5360A when used with a suitable phase shifting circuit).

3.2 EQUIPMENT REQUIRED

(a) 10 Hz to 100 KHz low distortion* oscillator, with output adjustable from 0.1 volts RMS to 10 volts RMS, Krohn-Hite Model 4000A or equivalent.

(b) 10 Hz to 10 MHz sine wave oscillator, with two outputs, 180° apart, and output voltage adjustable from zero to 1.5 volts RMS, Hewlett Packard Model 654A or equivalent.

(c) Variable phase generator, capable of providing two sine wave and/or square wave outputs, with adjustable phase angle from 0° to 360° Hewlett Packard Model 203A or equivalent.

(d) 10 Hz to 5 MHz square wave signal source, with two outputs, not in phase, and output voltage at least 1 volt peak to peak. (If a signal source with two outputs is not available, a single source may be used with a suitable balanced transformer such as the North Hills Electronics Model 50-201RA, to produce two outputs approximately 180° apart.)

(e) 50 ohm terminators, (2 required), Tektronix type 011-0055-00 or equal. (For use with above transformer only).

(f) Calibrated DPM, zero to -3.6 volts DC, with 0.1 millivolt resolution, Newport Model 2000AS or equal.

(g) Matched set of coaxial cables (BNC) for connections to inputs. (Same length and impedance).

* Less than 0.01% from 10 Hz to 20 KHz, rising to 0.1% at 100 KHz.

3.3 PROCEDURE

After allowing the instrument to warm up for at least 30 minutes, set the controls to the following positions:

WAVEFORM	
RMS VOLTS RANGE (input A)	0.1-1.2
RMS VOLTS RANGE (input B)	0.1-1.2
READ/HOLD	READ
GROUND SWITCH	CHASSIS

3.3.1 Meter Calibration

Press the 0° CAL button. Adjust the screwdriver control on the front panel until the meter reads 000.00°. Press the 360° CAL button. Adjust the screwdriver control on the front panel until the meter reads 360.00°.

3.3.2 100 Hz Sine Wave Check

Connect the output of the low distortion oscillator to both inputs of the phasemeter, using the set of matched cables. Set the oscillator frequency to 100 Hz, output amplitude to 0.1 volts RMS. Depress the 0° CAL button momentarily, then release; meter should read 000.00° ± 0.05°. Depress the 360° CAL button, then release; meter should read 360.00° ± 0.05°. Repeat procedure at 20 Hz, 1 KHz and 10 KHz.

3.3.3 10 Hz Sine Wave Check

Repeat procedure of 3.3.2 at 10 Hz; meter tolerance is ± 0.2°.

3.3.4 100 KHz Sine Wave Check

Repeat procedure of 3.3.2 at 100 KHz; meter tolerance is ± 0.7°.

3.3.5 High Frequency Sine Wave Check

Connect the outputs of the 10 MHz oscillator to the phasemeter inputs, using the matched cables. Set the oscillator frequency to 200 KHz and both output voltages to 0.1 volts RMS. Observe the phase reading.

Reverse the two inputs. Observe the phase reading. The Total* of both readings should equal 360.00° ± 2.8° at 200 KHz. Repeat this procedure at 500 KHz, 1 MHz, 2 MHz and 5 MHz. Tolerance of the total reading is ± 7° at 500 KHz, ± 14° at 1 MHz, ± 28° at 2 MHz and ± 70° at 5 MHz. Disconnect the oscillator.

3.3.6 100 Hz Square Wave Check

Set the phasemeter WAVEFORM switch to . Connect the outputs of the square wave signal source to the phasemeter inputs. (If a signal source with two outputs is not available, proceed as follows: Connect a single square wave source to the input of a suitable balancing transformer, as described in 3.2. c. The output impedance (Z) of the signal source should approximately equal the input Z of the transformer. Some transformers require a load on their outputs equal to their output Z. Check manufacturer's specifications). Set the signal source output voltage for 1 volt peak to peak at the phasemeter inputs. Observe the phase reading. Reverse the inputs and observe the reading. The Total* of both readings

* If both readings are in error by E degrees, the total will be off by (2xE) degrees. Therefore the tolerance of the total is twice the specified accuracy. (See Section 1.2)

should equal $360^\circ \pm 0.1^\circ$. Repeat this procedure at 10 Hz, 1 KHz and 5 KHz. Total of the two readings should be $360^\circ \pm 0.1^\circ$.

3.3.7 20 KHz Square Wave Check

Repeat the procedure of 3.3.6 at 20 KHz; total of the two readings should be $360^\circ \pm 0.2^\circ$.

3.3.8 High Frequency Square Wave Check

Repeat the procedure of 3.3.6 at 200 KHz, 500 KHz, 1 MHz, 2 MHz, and 5 MHz. Tolerance of the total reading from 360° should be $\pm 2.8^\circ$ at 200 KHz, $\pm 7^\circ$ at 500 KHz, $\pm 14^\circ$ at 1 MHz, $\pm 28^\circ$ at 2 MHz and $\pm 70^\circ$ at 5 MHz. Disconnect square wave source (and transformer if applicable).

3.3.9 Analog Output Check

Set the phasemeter WAVEFORM switch to \sim . Connect the sine wave outputs of the variable phase generator to the phasemeter inputs. Set the generator frequency to 1 KHz, output voltage to 1 volt RMS. Connect the DVM to the analog output. Check to see that the analog output is approximately -10 mv/degree for any phase angle between 0° and 360° .

3.3.10 Read/Hold Control Check

Set the output angle of the variable phase generator to some angle between 0° and 360° . Press the front panel HOLD button. Remove the phasemeter inputs. The last meter reading should remain stored until the READ button is pressed.

NOTE

The analog output voltage will still vary with a change in the input phase angle, even though the meter display is in the HOLD mode.

3.3.11 Optional BCD Output Check

The operation of the phasemeter's optional BCD output can be checked by connecting the variable phase generator to the phasemeter inputs, and measuring the logic levels on the respective pins for the meter readings listed in Table 1, Page 10. It may be necessary to use a large angle to measure the BCD outputs of phase angles less than 1.0° , for example, 200.01 , 200.02 , etc. Be sure to connect the common or ground lead of the DVM to the BCD output Digital Ground (pins E, L or S).

To check the "Conversion Complete" output (pin a), the logic level should remain "high" when the meter reading is stable. To check the "low" condition, depress either the 0° CAL or 360° CAL button; the level at pin a should go "low" while the meter reading is converting.

To check the "Transfer Inhibit" input, place the READ/HOLD switch in the HOLD mode. Vary the phase angle of the generator. The meter reading should not change. Connect a jumper from pin b to pin E, L or S and vary the phase angle of the generator; the reading should vary as the phase angle is varied.

SECTION 4 CIRCUIT DESCRIPTION

4.1 SYSTEM OPERATION

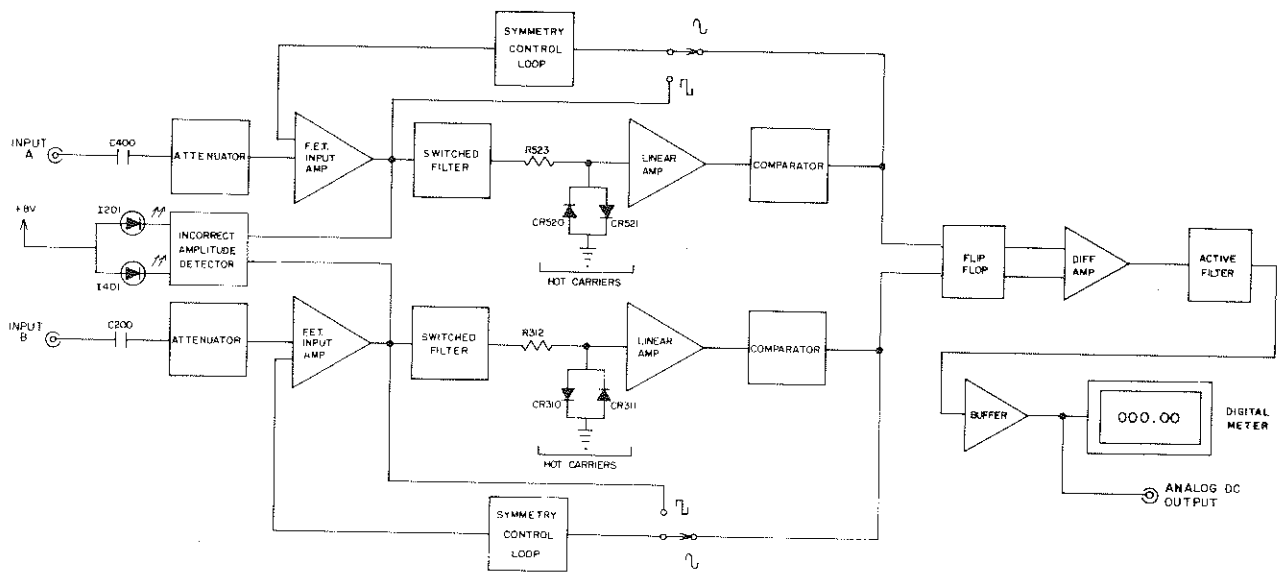

Figure 6. Simplified Block Diagram

A simplified block diagram of the phasemeter circuit is shown in Figure 6. A reference signal is applied to the A input and the signal to be measured is applied to the B input. Each input signal goes through a coupling capacitor, an attenuator, a high impedance (FET) amplifier for isolation and a switched filter that reduces any high frequency signals or noise. Each signal is then fed to a high speed comparator. The comparator detects the point where the input signal crosses the zero axis, and produces a square wave. The output of each comparator is then used to trigger a bi-stable flip flop. The output of the flip flop is a square wave, with a duty cycle that is proportional to the time between the two trigger inputs. The DC average of the accurately clamped flip-flop output is displayed by a digital meter, and corresponds to the phase angle, in degrees, between the two input signals.

4.2 ATTENUATOR AND FET INPUT AMPLIFIER (see figure 6)

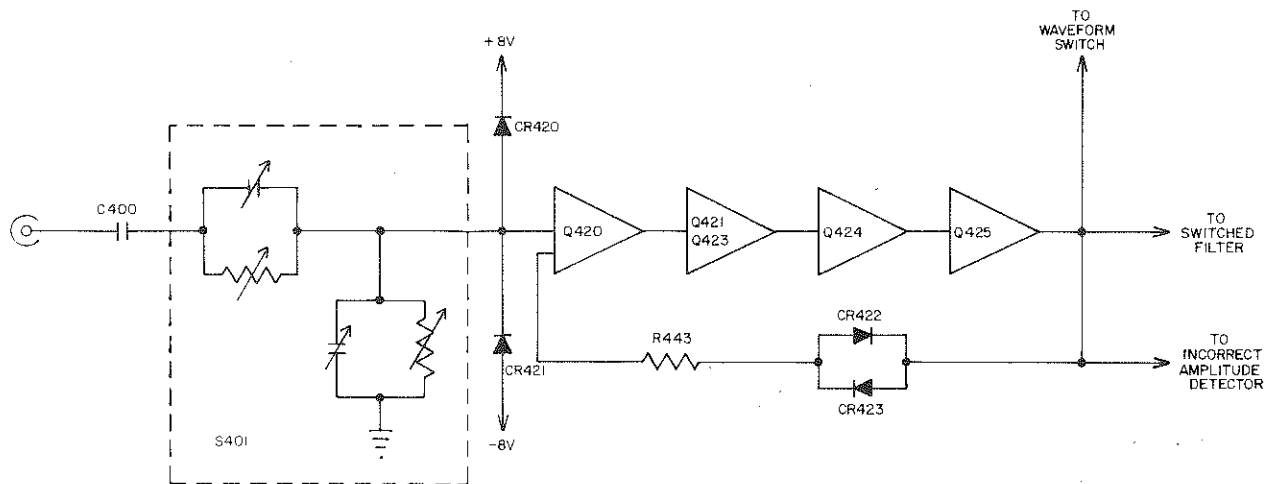

Figure 7. Attenuator and Fet Input Amplifier

(NOTE: since both channels are similar up to their comparator outputs, we shall limit part of the circuit description to channel A.)

The input signal first goes through an AC coupling capacitor, C400, that is matched with C200 for equal low frequency phase shift. The signal is then fed to an attenuator that provides a constant input impedance on all three ranges. Capacitors C401 through C411 are used for broadbanding and to keep the impedance the same on all three ranges at high frequencies. Diodes CR420 and CR421 on the attenuator output prevent damage of the FET amplifier by excessive input signal levels.

The FET amplifier is a high impedance non-inverting amplifier with gain, and consists of an input stage Q420, a balanced differential stage Q421 and Q423, a driver stage Q424, and an emitter follower Q425. The amplifier provides both isolation and gain between the attenuator and the switched filter (section 4.4.) A degenerative path from the amplifier output through CR422, CR423 and R443 limits the amplifier gain and output swing.

4.3 INCORRECT AMPLITUDE DETECTOR (see figure 8)

The incorrect amplitude detector monitors the output of the Fet amplifier. When the input signal voltage falls within the attenuator voltage range selected, the positive DC voltage developed on C464 opens diodes CR 464 and CR465, so that the current in R475 turns Q461 on, turning off Q460, and turning off the LED Set Range Indicator. When the input signal exceeds the upper limit of the attenuator range, the negative DC voltage developed across C463 is sufficient to turn on CR466, turning off Q461 and turning on the LED. When the input signal falls below the selected range Q461 is shut off by the current from the -8v supply through R478, CR464 and CR465. Diode CR465 is in series with CR464 for temperature compensation.

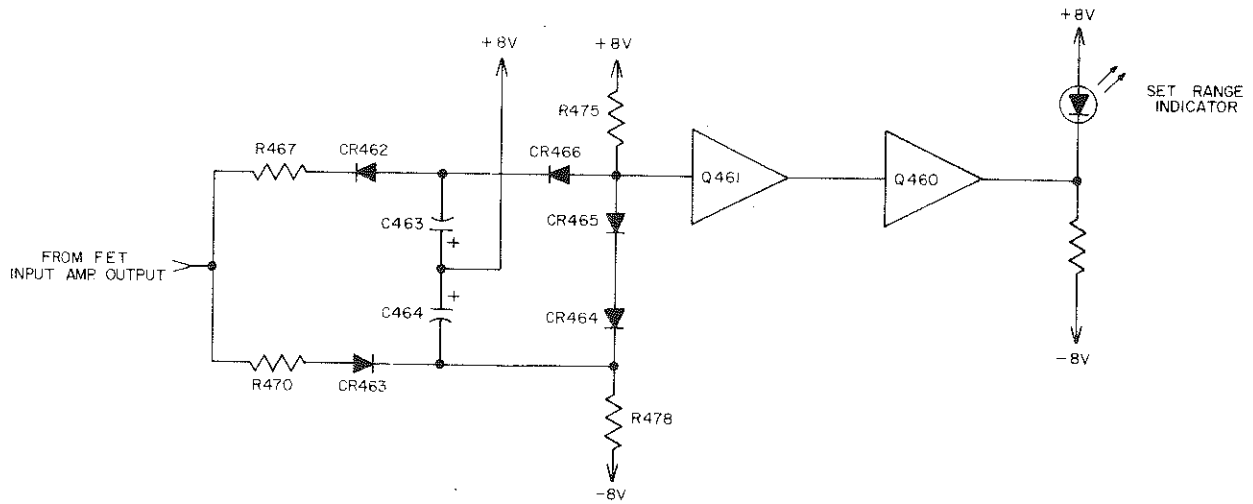

Figure 8. Incorrect Amplitude Detector

4.4 SWITCHED FILTER AND HOT CARRIER LIMITER (see figure 9)

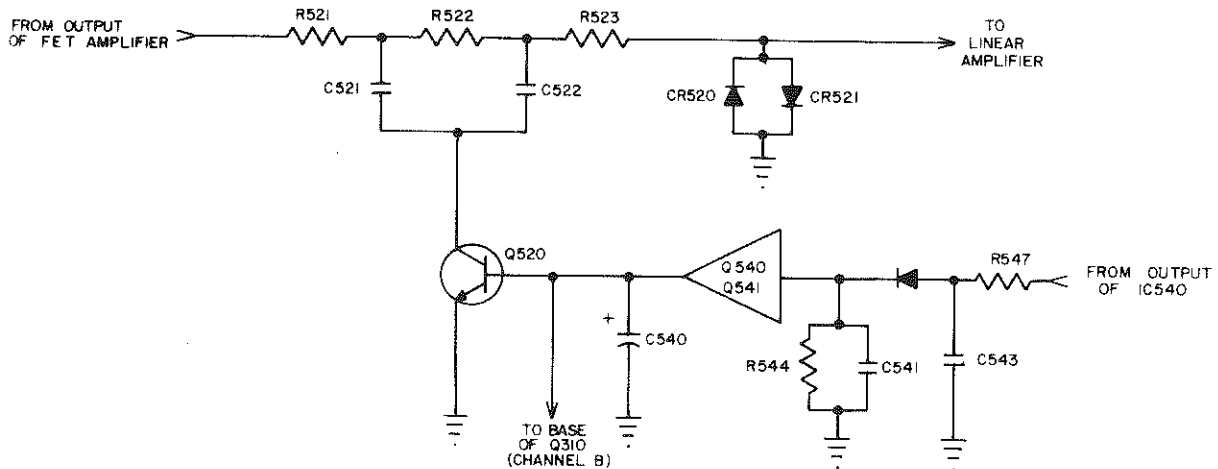

Figure 9. Switched Filter and Hot Carrier Limiter

The switched filter is a low pass filter that is used to reduce excessive high frequency noise at input frequencies below 200 Hz. The control signal is taken from the output of IC540. At low frequencies, the control signal charges C541, turning on Q541 and Q540. This drives the base of Q520 plus, providing a path to ground for C521 and C522.

At frequencies above 200 Hz, the control signal is removed by a bypass capacitor C543, discharging C541, and turning off Q541 and Q540. This drives the base of Q520 negative and opens the path to ground.

The hot carrier limiter consists of two diodes CR520 and CR521. These diodes clamp the input signal at a level of approximately + 0.3 volts and - 0.3 volts.

4.5 LINEAR AMPLIFIER (see figure 10)

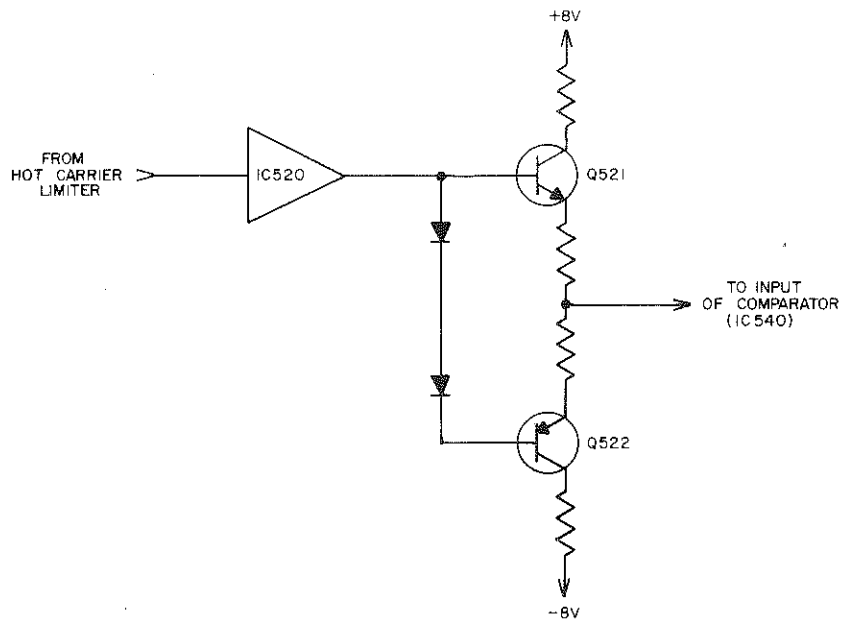

Figure 10. Linear Amplifier

The linear amplifier is an inverting amplifier with gain and consists of an integrated circuit IC520 and a push-pull emitter follower Q521 and Q522. The amplifier serves two purposes: (1) although the hot carrier limiter clamps its input signal at 0.3 volts, the slope of the clamped signal will vary with the amplitude of the input signal, which in turn will affect the point where the comparator is triggered. The linear amplifier provides sufficient gain so that the difference in the slope is negligible; (2) since the output of the limiter is not sufficient to drive the low impedance of the comparator, the linear amplifier provides the current needed.

4.6 COMPARATOR (see figure 11)

The comparator consisting of IC540 converts the output of the linear amplifier to a fast square wave that is clamped at + 10 volts by CR545. The negative excursion of each comparator is capacitively coupled to the flip flop.

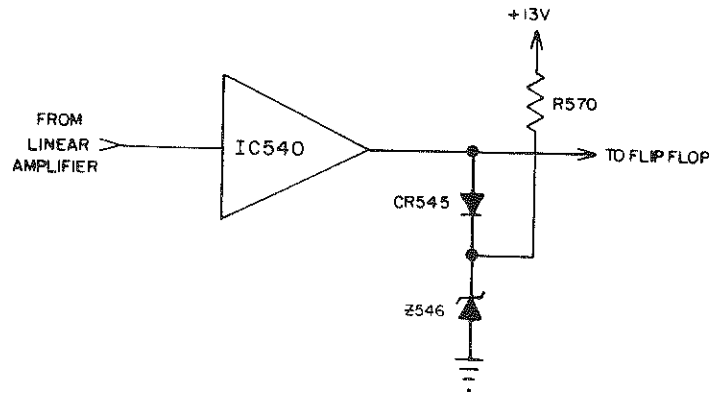

Figure 11. Comparator

4.7 SYMMETRY CORRECTION LOOP (see figure 12)

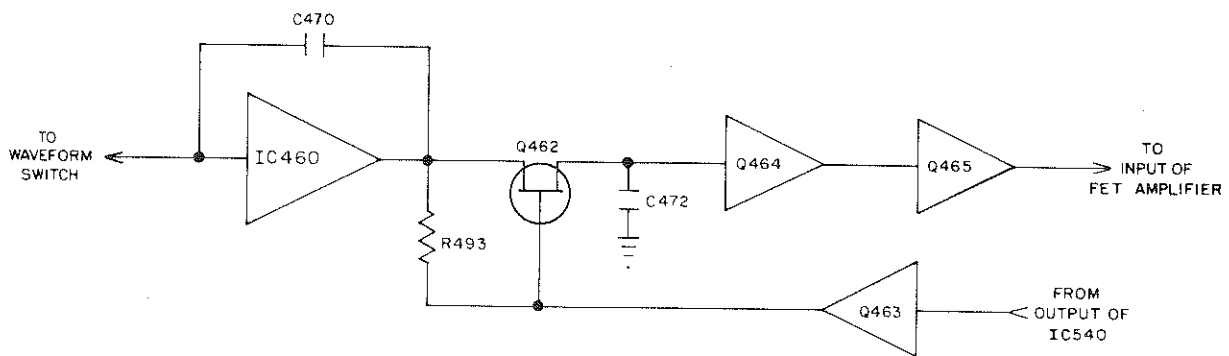

Figure 12. Symmetry Correction Loop

The symmetry correction loop is switched in when the Waveform switch is set to the \sim mode, and consists of an integrator IC460 and C470, a gated filter Q462 and Q463 and buffers Q464 and Q465. The purpose of this loop is to compensate for phase errors caused by a shift in the DC level of the input signal, which shifts the zero crossover point. The symmetry loop averages the output of the comparator signal from Q466 and Q467 and the resultant DC voltage is fed back to the complementary input of the FET amplifier. If there is no shift in the DC level of the input signal, the signal from Q466 and Q467 will be symmetrical about zero volts, and the DC average will be zero. If a level shift occurs, the square wave signal from Q466 and Q467 will no longer be symmetrical about zero volts, and the average DC voltage from Q466 and Q467 will be fed back to the FET amplifier input and cancel the error.

4.8 FLIP FLOP (see figure 13)

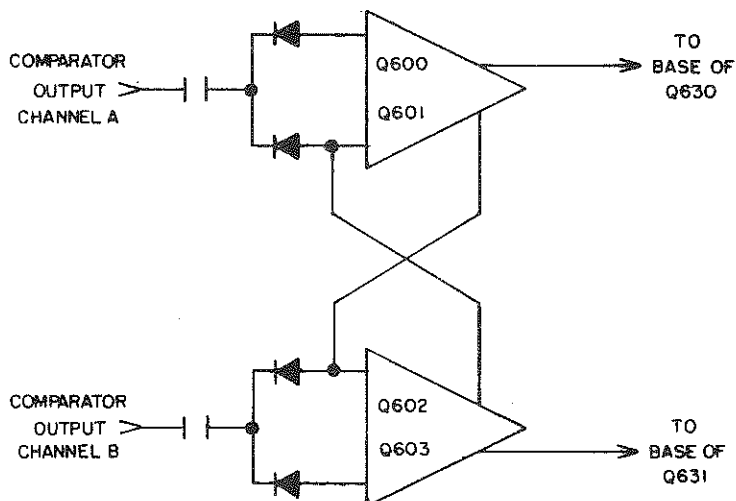

Figure 13. Flip Flop

The Flip Flop consisting of Q600, Q601, Q602 and Q603 operates in a bi-stable non-saturating mode, and is triggered on the negative excursion of each comparator output. The outputs are taken from the collectors of Q601 and Q602.

4.9 DIFFERENTIAL AMPLIFIER AND METER NETWORK (see figure 14)

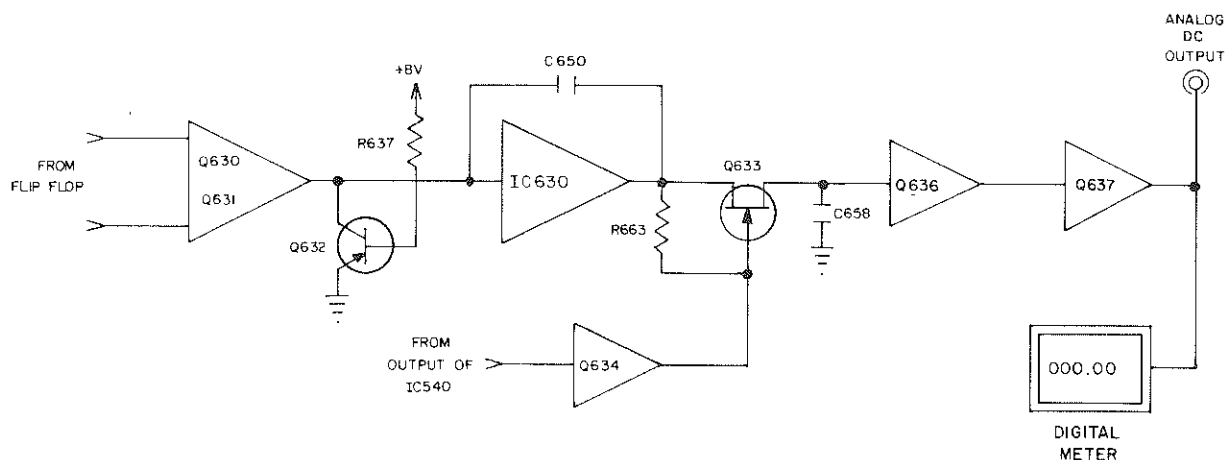

Figure 14. Differential Amplifier and Meter Network

The push-pull output of the flip flop is fed to a differential amplifier Q630 and Q631, which cancels any drift and increases the amplitude of the flip flop output. The base to emitter junction of Q632 functions as a zener, and the base to collector junction clamps the output of the Differential Amplifier at approximately + 6 volts.

The output of the Differential Amplifier is converted to a DC voltage by an active filter, IC 630 and a gated filter Q633 and Q634, providing additional smoothing of the active filter output.

A buffer stage, Q636 and Q637 provides isolation between the gated filter and the digital meter.

The digital meter displays the resultant DC voltage, which corresponds to the phase angle in degrees, between the two input signals.

4.10 POWER SUPPLIES (see figure 15)

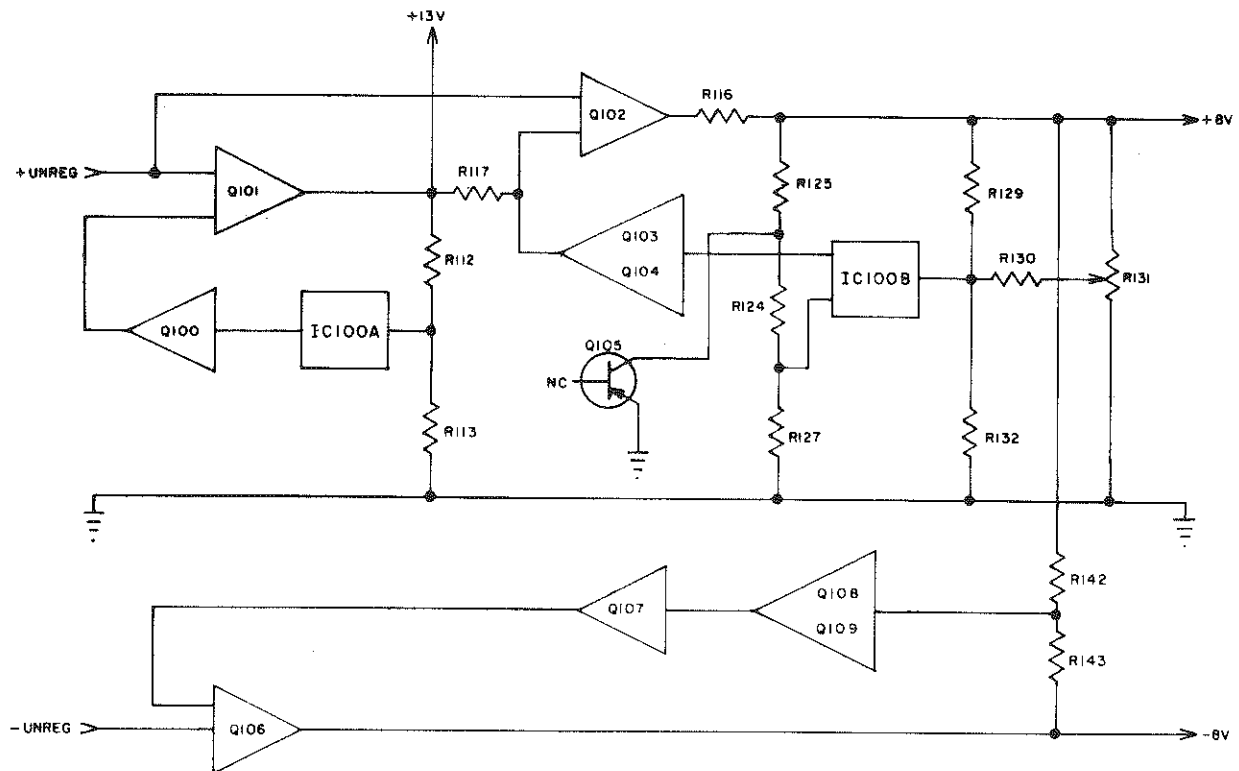

Figure 15. Power Supplies

There are three supply voltages used in the Phasemeter. The ± 8 volt supply is used to power the IC's, and wherever a large signal swing is not needed. The + 13 volt supply is used to provide the additional voltage swing needed on the outputs of the comparator and differential amplifier. Q105 is used as a zener reference for the + 8 volt master supply. IC100 is used for improved temperature compensation.

SECTION 5 MAINTENANCE

5.1 INTRODUCTION

If the Phasemeter does not appear to be working properly, the following procedure may facilitate locating the source of trouble. First, check to see if all controls are properly set, and all external connections have been made. Next, make a visual inspection of the unit to locate any broken wires or burnt or broken components. If a visual inspection does not locate the source of trouble, the troubleshooting procedure given in this section should help to localize the problem. Before attempting any detailed troubleshooting however, reference should be made to Section 4, Circuit Description.

5.2 TEST EQUIPMENT REQUIRED

- (a) 10 Hz to 100 kHz low distortion* oscillator, with two outputs 180° apart, adjustable from 0.1 volts RMS to 10 volts RMS.
- (b) Oscilloscope, with 1 mv/cm sensitivity and bandwidth of at least 45 MHz, Tektronix type 7403N or equal, with 7B50 Time Base and 7A13 Differential Comparator Amplifier.
- (c) Digital voltmeter, zero to 15 volts DC, with 1 mv resolution.
- (d) Matched set of coaxial cables (BNC) for connections to inputs. (Same length and impedance).

5.3 POWER SUPPLY

If the phase meter does not seem to be working properly, the power supply circuit should be checked first. The three regulated outputs should measure $+8V \pm 0.2V$, $-8V \pm 0.2V$, and $+13V \pm 0.3V$. Normal 60 Hz ripple should be less than 2 mv peak to peak. If the preceding three voltages appear to be correct, go to Section 5.4.

The regulated voltages are provided with current limiting circuits that will shut down the supply when excessive current is being drawn from it. Because of this, an apparent power supply malfunction may be the result of an overload in the phase meter circuits. This may be determined by measuring the voltage drop across R104, R116 and R134. These voltages should be no greater than 0.7V. If the voltage across R104, R116, or R134 is considerably greater than 0.7V, measure the voltage across the three power supply PC busses which feed the left channel, the right channel and the rear card circuits. A drop of over 10 millivolts on any of these will indicate that the overload is in that section.

* Less than 0.01% from 10 Hz to 20 kHz, rising to 0.1% at 100 kHz.

Check the unregulated voltages on the + end of C103 and the - end of C104. If these voltages are correct and if there is no indication of overload, but the +8V regulated output is not correct, check the +8V supply first, because it is the reference for the other supplies. If the +13V (as well as the +8V) is low, connect a 4.7K resistor from the collector of Q103 to the + end of C103. If this corrects the +8V, but not the +13V, the trouble is in the +13V supply.

Normal voltages for various points are given on the schematic diagram in the appendix. A good way to find the source of trouble in any of the three supplies is to trace the error signal developed. For example, if the -8V supply were to become less negative than normal, the base of Q109 would tend to become more positive, allowing less current to flow through it and R140, making both the collector of Q109 and the base of Q107 more negative. This would allow more current to flow through Q107 and make its collector more positive, thus turning on the series transistor Q106 and restoring the -8V supply to its normal level.

NOTE: Most of the circuitry discussed in the following sections is of high impedance making it necessary to use high impedance, low capacitance equipment when making AC or DC measurements.

5.4 SIGNAL TRACING ANALYSIS

If the power supply seems to be functioning properly then the following procedure should localize the malfunction. Set both attenuator switches to the 0.1V-1.2V position. Apply two 1 kHz, 0.1V rms sine waves, 180° apart, to the inputs of the phasemeter. Set the MODE switch to the \sim position. The schematic shows various test points with their correct signal levels. The test points basically trace the signal through the entire system. A quick look at either the Block Diagram (Figure 5, Section 4) or the detailed schematic (appendix) will show that before the two input signals reach the flip-flop, they are processed independently by identical circuitry. Therefore the notation Q222 (Q423) implies that Q222 and Q423 have identical functions in their respective channels.

5.5 FET AMPLIFIER

If test point TP1(6) appears incorrect check Q220 (Q420), CR220 (CR420) and CR221 (CR421). If test point TP1 (6) is normal but test point 2(7) is in error first check the output from the symmetry correction loop on TP11 (TP12). If this value is greater than 0.35 volts DC, switch the sine-square switch to square wave. If the output of the symmetry loop is then less than ± 0.35 volts DC, the trouble is probably in the limiter (section 5.10), the Linear Amplifier (Section 5.6) or the Comparator (Section 5.7). If there is still more than ± 0.35 volts DC, the malfunction is likely to be in the symmetry loop or its associated gated filter or buffer.

If the preceding voltage check shows no malfunction in these circuits, then the malfunction is somewhere between Q221 (Q421) and Q225 (Q425). The signal error can be traced back from test point 2 in the direction of Q221 until the faulty component(s) is (are) located.

5.6 LINEAR AMPLIFIER

If the DC voltage on TP3 (8) is incorrect tie pin 5 to pin 10 of IC310 (IC520). Pin 5 should be zero volts, and TP3 (8) should be approximately -0.6V. If TP3(8) is not -0.6V, check the two diode drop from pin 5 of IC310 (IC520) to the base of Q312 (Q522). This should be around 1.2V. If this checks out and pin 5 of IC310 (IC520) is at 0.0V then the malfunction is associated with either Q311 (Q521) or

Q312 (Q522). If pin 5 of IC310 (IC520) is not zero, check to see that the plus and minus supplies reach their respective pins on IC310 (IC520). If they do, then IC310 (IC520) is the source of the problem. If TP3(8) does go to -0.6V check the negative feedback loop from TP3 to pin 10 to see if there is an open circuit. If not, the malfunction is probably between TP2 and the inputs of IC310 (IC520). The problem can be further localized by tracing the signal from TP2 towards IC310 (IC520).

5.7 COMPARATOR

First check pin 3 of IC330 (IC540) to see that the signal, normally around 8V p-p, reaches it from TP3(8). If not, check the components between the two above mentioned points. There is a small amount of regenerative feedback from the output (pin 7 of IC330 (IC540)) to the + input (pin 2), but the DC signal level at pin 2 should not be much greater than 100 mv p-p. If it is, check the feedback circuitry. If both inputs appear normal but the output, pin 7, refuses to change state (OV or +10V) in response to pin 3, the problem is probably with IC330 (IC540) but it could also be accounted for if CR331 (CR546) has gone bad or CR330 (CR545) is shorted.

5.8 FLIP FLOP AND DIFFERENTIAL AMPLIFIER

Depress the 0° CAL button and then the 360° CAL button while monitoring the DC level at TP 4. The voltages should be approximately OV and 6.6V for 0° and 360° respectively. Correct values here indicate that the source of the problem is after the Differential Amplifier. If these voltages are incorrect, monitor the collector of Q630 in the 0° and 360° cal modes. Correct levels here are -0.5V and 8.5V for 0° and 360° respectively. Repeat for Q631. Correct levels here are 8.5V and -0.5V for 0° and 360° respectively. Correct levels here indicate the malfunction is between the two above mentioned collectors and TP4. If these voltages are incorrect check the DC levels at the collector of Q602 in the 0° and 360° cal. modes. Correct values are 9.5V and 8V respectively. Using this same procedure check the 0° and 360° CAL levels at the collector of Q601. Correct levels are 8V and 9.5V respectively. Proper levels at the collectors of Q601 and Q602 indicate that Q630 or Q631 or their associated circuitry is the source of the malfunction. Incorrect voltages at the collectors of Q601 and Q602 indicate a malfunction in the flip-flop or the calibration switch. Check the switch for faulty contacts. If the switch seems in order, then the malfunction is most likely associated with the four transistors that make up the flip-flop. Measure the emitter to base voltage drop in each of the four transistors while in the 360° and 0° CAL modes. In at least one of the two CAL positions the transistor in question should show a minimum voltage drop of -0.6V. (On 0° CAL, Q600 and Q602 are "on" and Q601 and Q603 are biased off. On 360° CAL, Q600 and Q602 are biased off and Q601 and Q603 are "on").

5.9 ACTIVE FILTER LOOP, GATED FILTER AND BUFFER

For this section it will be necessary to short pin 5 to pin 10 of IC630. This can be most easily done by putting a jumper wire across C650. The DC level at pin 5 should now be OV plus a small offset (a max. of ±15 mv). If not, check the DC level of pin 9 of IC630. If this does not produce results IC630 is probably the source of trouble. If pin 5 showed only the acceptable offset check the DC level at the drain of Q633. It should have essentially the same value as pin 5 of IC630. Monitor the signal level at the collector of Q634. There should be a base line DC level of -7V with pulses to +7V. (DC average

approx. -4.6V). If not check Q634 and CR637. Monitor the signal level at the base of Q634. There should be a base line DC level of -7V with pulses to -12V. If not check CR548, C547, and R574. Check the DC level at the source of Q636 (R679). This should be $\pm 0.3V$, $\pm 0.2V$. If not check the voltage drop across CR640. If it is normal (between 0.5V and 0.8V), Q636 is probably bad. If the drop across CR640 is not within these normal limits set, check the diode itself. Monitor the DC level at the base of Q637. It should be around -0.65V. If not check R679. Check the DC level at the emitter of Q637. This voltage should be around -1.3V. If not, Q637 is probably the source of trouble.

5.10 LIMITER

If the limiter output at the junction of R294 (R505) and R295 (R506) is not swinging sufficiently positive, the trouble may be Q266 (Q466). If this output is not negative enough, the trouble may be Q267 (Q467) or the driver Q268 (Q468) or the associated circuitry.

5.11 SYMMETRY CORRECTION, GATED FILTER, BUFFER

In this section it will be necessary to short pin 5 to pin 10 of IC260 (IC460). This can be most easily done by placing a jumper wire across C270 (C470). The DC level at pin 5 should now be 0V except for a small offset (a max. of ± 15 mv). If not check R283 (R487). If this does not produce results IC260 (IC460) is probably the source of trouble. If pin 5 showed only the acceptable offset check the DC level at the drain of Q262 (Q462). It should have essentially the same value as pin 5 of IC260 (IC460). Monitor the signal level at the base of Q263 (Q463) to see that the comparator output reaches it. The signal should be around -7 VDC base line with pulses to -12V. Check the signal level at the gate of Q262 (Q462). This point should be around -8V DC base line with pulses to +2.5 V. If not, check Q262 (Q462) and Q263 (Q463). Monitor the DC level at the source of Q264 (Q464). The correct value here is about +2 VDC. If this disagrees with the measured value check R287 (R497), R289 (R498) and Q264 (Q464). In narrowing down the malfunction to the faulty component, it will be helpful to note that the base of Q265 (Q465) should be around +0.5 VDC. Check the DC level at TP11 (TP12) [emitter of Q265 (Q465)] for a value of $0 \pm 0.6V$. If the measured value is very different, Q265 (Q465) is probably defective.

5.12 SET RANGE INDICATORS

If the LED Set Range Indicators are not working properly, proceed as follows:

Apply a .08 volt RMS, 100 Hz sine wave to both inputs of the phasemeter. Set the VOLTS RANGE switches to 0.1-1.2, WAVEFORM switch to \sim . Adjust R273 (R477) until the LED flickers or just goes out. If R273 (R477) cannot be adjusted properly then Q260 (Q460) or Q261 (Q461) or their associated components are defective. (Refer to Section 4.3.)

SECTION 6 CALIBRATION

6.1 INTRODUCTION

The following procedure is provided for periodic calibration and adjustment of the phasemeter in the field, and adherence to this procedure should restore the phasemeter to its performance specifications. All tests should be made with covers in place. If the phasemeter cannot be calibrated by the procedure given, refer to Maintenance, Section 5, or consult our factory service department. The location of test points and adjustable components are shown in Figure 16.

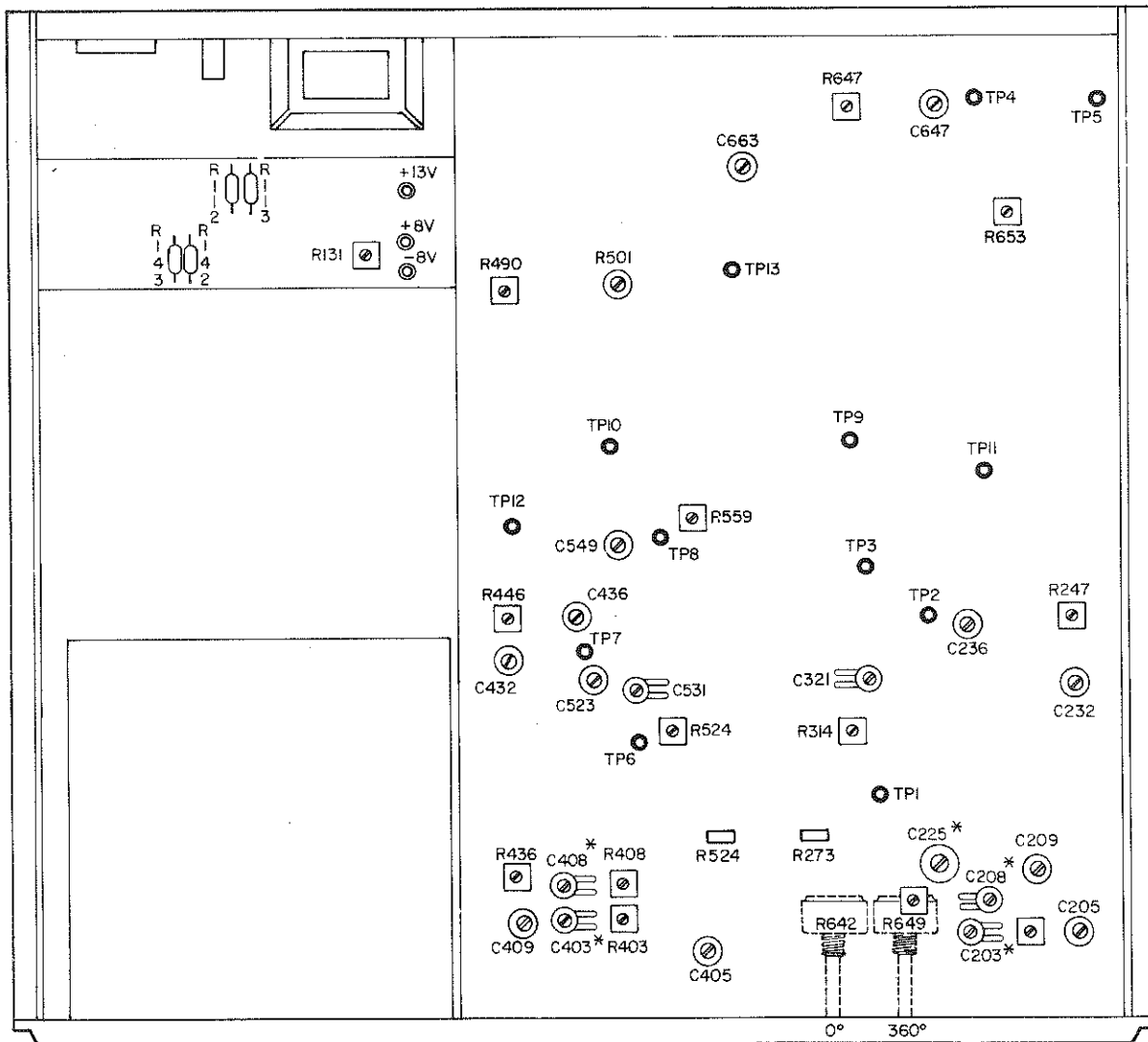

*(These trims may be adjusted through slots provided in the top cover of the instrument.)

Figure 16. Test Points and Adjustable Components

SPECIAL NOTE

As an alternate to the following procedure, a Primary Phase Angle Standard such as the Dytronics Model 311/RT-1/717S may be used for accuracy measurements between 30 Hz and 10 KHz. A second alternative is the use of a Computing Counter System such as the Hewlett Packard Model 5360A when used with a suitable phase shifting circuit).

6.2 TEST EQUIPMENT REQUIRED

(a) Oscilloscope, with 1 mv/cm sensitivity and bandwidth of at least 45 MHz, Tektronix type 7403N or equal, with 7B50 Time Base, 7A13 Differential Comparator Amplifier and calibrated X1 probe.

(b) 10 Hz to 100 KHz low distortion* oscillator, with 200 ohm main and quadrature outputs adjustable from 0.1 volts RMS to 10 volts RMS, Krohn-Hite Model 4024A or equivalent.

(c) 10 Hz to 10 MHz sine wave oscillator, with 135 ohm balanced outputs (67.5 ohms each output), adjustable from zero to 1.5 volts RMS, Hewlett Packard Model 654A or equivalent.

(d) 10 Hz to 10 MHz sine/square generator, output adjustable from zero to 10 volts RMS, Krohn-Hite Model 4300A or equivalent.

(e) Digital voltmeter, zero to 15 volts DC, with 1 mv resolution, Fluke Model 8000A or equivalent.

(f) AC differential voltmeter, 10 mv to 10 volts RMS, Fluke Model 931A or equivalent.

(g) Wideband attenuator, 50 ohm input and output impedance, Texscan Model LA-51 or equivalent.

(h) X10 oscilloscope probes (2 required), Tektronix type P6006, P6049A or P6060.

(i) 75 ohm terminator (2 required), Tektronix type 011-0055-00 or equal.

(j) 50 ohm terminator, Tektronix type 011-0049-01 or equal.

(k) Matched set of coaxial cables (BNC) for connections to inputs. (Same length and impedance).

6.3 TEST PROCEDURE

After allowing the unit to warm up for at least 30 minutes, set the controls to the following positions:

WAVEFORM	
RMS VOLTS RANGE (input A)	0.1-1.2

* Less than 0.01% from 10 Hz to 20 KHz, rising to 0.1% at 100 KHz.

RMS VOLTS RANGE (input B)	0. 1-1. 2
READ/HOLD	READ
GROUND SWITCH	CHASSIS

6.3.1 Power Supplies

Check the voltages at the following test points, and adjust if necessary.

<u>Test Point</u>	<u>Value</u>	<u>Adjustment</u>
TP + 8	+8V \pm 0. 2V	R131
TP + 13	+13V \pm 0. 3V	R112, R113
TP - 8	-8V \pm 0. 2V	R142, R143

6.3.2 0° and 360° CAL Adjust

Set the front panel 0° ADJ pot (R642) for 0 \pm 0. 1 volts DC on its center arm. Adjust R647 for 0 \pm 1 mv at TP4. Depress the 0° CAL button. Adjust R642 for a meter reading of 000. 00°.

Set the front panel 360° ADJ pot (R649) for the center of its range. Depress the 360° CAL button and adjust R653 for a meter reading of 360. 00°.

6.3.3 Symmetry Correction Loop Adjust

Connect one of the outputs of the balanced oscillator to channel A; connect the other output to channel B. Set the oscillator frequency to 1 KHz, output to 1V RMS at each phasemeter input. Adjust R247 for 0 \pm 0. 1 volts DC at TP11. Adjust R446 for 0 \pm 0. 1 volts DC at TP 12. Disconnect the balanced oscillator.

6.3.4 0° and 360° Calibration (100 Hz)

Depress the phasemeter 0° CAL button. Adjust the 0° ADJ pot for a reading of 000. 00°. Depress the 360° CAL button. Adjust the 360° ADJ pot for a reading of 360. 00°.

Connect the output of the low distortion oscillator to both inputs of the phasemeter, using a matched set of coaxial cables. Set oscillator frequency to 100 Hz, output to 0. 1 volts RMS. Depress the 0° CAL button momentarily, then release. Meter should read 000. 00. ° If off, adjust R501.

Depress the 360° CAL button momentarily, then release. Meter should read 360. 00°. If off, adjust R490. Recheck 0° CAL and readjust, if necessary. Disconnect the oscillator.

6.3.5 Phase Vs. Amplitude, Input A

Connect the low distortion oscillator and wideband attenuator to the phasemeter as shown in Figure 17. Set the oscillator frequency to 10 KHz, and adjust the main and quadrature outputs for 1 Volt RMS at each phasemeter input. Adjust R524 for a minimum change in meter reading when switching the wideband attenuator from 0 db to 20 db. Tolerance: \pm 0. 01°.

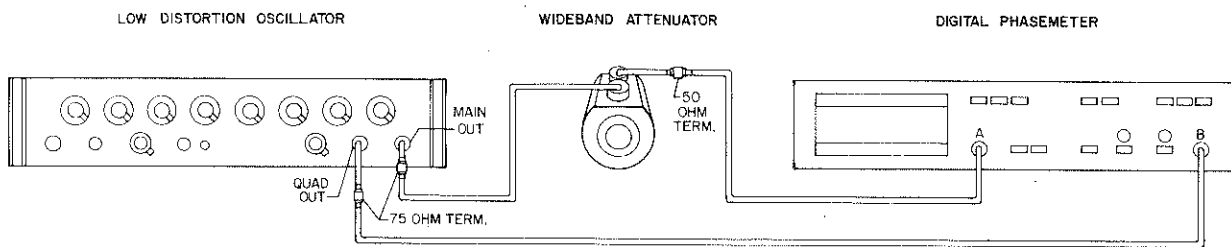

Figure 17. Phase Vs. Amplitude, Input A, Test Set-up

Set oscillator to 50 KHz. Maintain 1 volt RMS on phasemeter inputs. Adjust C531 for a minimum change in meter reading when switching the wideband attenuator from 0 db to 20 db. Tolerance: $\pm 0.01^\circ$.

Switch wideband attenuator from 0 db to 10 db. Adjust C436 for a minimum change in meter reading. Tolerance: $\pm 0.01^\circ$.

6.3.6 Phase Vs. Amplitude, Input B

Connect the low distortion oscillator and wideband attenuator as shown in Figure 18. Set the oscillator frequency to 10 KHz, and adjust the main and quadrature outputs for 1 volt RMS at each phasemeter input. Adjust R314 for a minimum change in meter reading when switching the wideband attenuator from 0 db to 20 db. Tolerance: $\pm 0.01^\circ$.

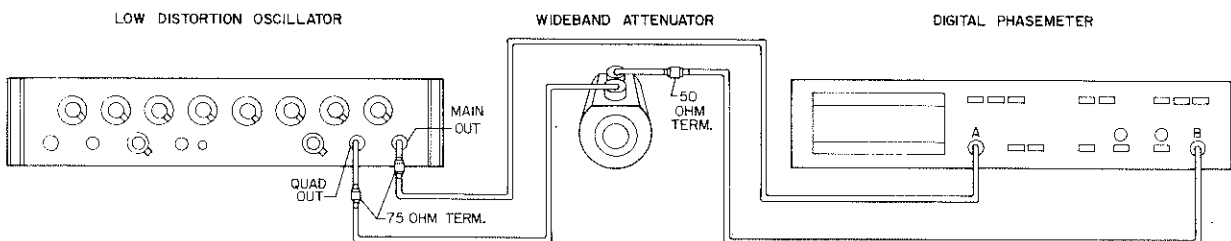

Figure 18. Phase Vs. Amplitude, Input B, Test Set-up

Set oscillator to 50 KHz. Maintain 1 volt RMS on phasemeter inputs. Adjust C321 for minimum change when switching wideband attenuator from 0 db to 20 db. Tolerance: $\pm 0.01^\circ$.

Switch wideband attenuator from 0 db to 10 db. Adjust C236 for a minimum change in meter reading. Tolerance: $\pm 0.01^\circ$. Remove terminators, attenuator and quadrature output from phasemeter.

6.3.7 Phase Vs. Frequency Adjust

Reset 0° CAL and 360° CAL adjust (if necessary). Connect the main output of the low distortion oscillator to both inputs of the phasemeter, using matched cables. Set oscillator frequency to 100 Hz, output to 0.1 volts RMS. Depress 0° CAL button momentarily, then release. Meter should read 000.00° . If off, readjust R501.

Set oscillator frequency to 50 KHz. Maintain 0.1 volts RMS on oscillator output. Depress 360° CAL button momentarily, then release. Adjust C225 for a meter reading of 360.00°, ±0.03°.

Set oscillator frequency to 100 KHz, output at 0.1 volts RMS. Depress the 360° CAL button momentarily, then release. Adjust R436 for a reading of 360.00° ± 0.07°. Recheck 50 KHz.

6.3.8 Phase Vs. Attenuator Setting, Input A

Change oscillator frequency to 10 KHz, output to 1 volt RMS. Depress 360° CAL button momentarily, then release. Meter should read 360.00°. Switch input A attenuator to 1-12V position. Adjust C403 for minimum change when switching from 0.1-1.2 V to 1-12 V position. Tolerance: ±0.02°.

Switch input A attenuator to 0.1-1.2V position. Change oscillator frequency to 40 KHz. Depress 360° CAL button momentarily, then release. Switch input A attenuator to 1-12V position. Adjust R403 for minimum change. Tolerance ±0.02°.

Set both input attenuators to the 1-12V position. Change the oscillator frequency to 10 KHz, output to 10 volts RMS. Depress 360° CAL button momentarily, then release. Meter should read 360.00°. Switch input A attenuator to 10-120 V position. Adjust C408 for minimum change. Tolerance: ±0.02°.

Switch input A attenuator to 1-12V position. Change oscillator frequency to 40 KHz, output at 10 volts RMS. Depress 360° CAL button momentarily, then release. Meter should read 360.00°. Switch input A attenuator to 10-120V position, Adjust R408 for minimum change. Tolerance: ±0.02°.

6.3.9 Phase Vs. Attenuator Setting, Input B

Set both input attenuators to 0.1-1.2V position. Set oscillator frequency to 10 KHz, output to 1 volt RMS. Depress 0° CAL button momentarily, then release. Meter should read 000.00°. Switch input B attenuator to 1-12V position. Adjust C203 for minimum change. Tolerance: ±0.02°.

Reset input B attenuator to 0.1-1.2V position. Set oscillator frequency to 40 KHz, output to 1 volt RMS. Depress 0° CAL button momentarily, then release. Meter should read 000.00°. Switch input B attenuator to 1-12V position. Adjust R203 for minimum change. Tolerance: ±0.02°.

Set both input attenuators to 1-12V position. Change oscillator frequency to 10 KHz, output to 10 volts RMS. Depress 0° CAL button momentarily, then release. Meter should read 000.00°. Switch input B attenuator to 10-120V position. Adjust C208 for minimum change. Tolerance: ±0.02°.

Switch input B attenuator to 1-12V position. Change oscillator frequency to 40 KHz, output to 10 volts RMS. Depress 0° CAL button momentarily, then release. Meter should read 000.00°. Switch input B attenuator to 10-120V position. Adjust R208 for minimum change. Tolerance: ±0.02°. Disconnect phasemeter inputs.

6.3.10 Attenuator Impedance Adjust (Inputs A and B)

Connect a square wave generator to the phasemeter inputs, using two (2) x 10 probes as shown in Figure 19. Set input attenuators to 0.1-1.2V, phasemeter waveform switch to \square . Set the generator frequency to 1 KHz, output to .3V p-p. Connect the oscilloscope, using a calibrated X10 probe to phasemeter TP7. Set the oscilloscope for 10 mv/cm, Cal., AC coupled, horizontal to .2 ms/cm Cal. Adjust the probe connected to input A for a good square wave on the scope. (A slight ringing is normal).

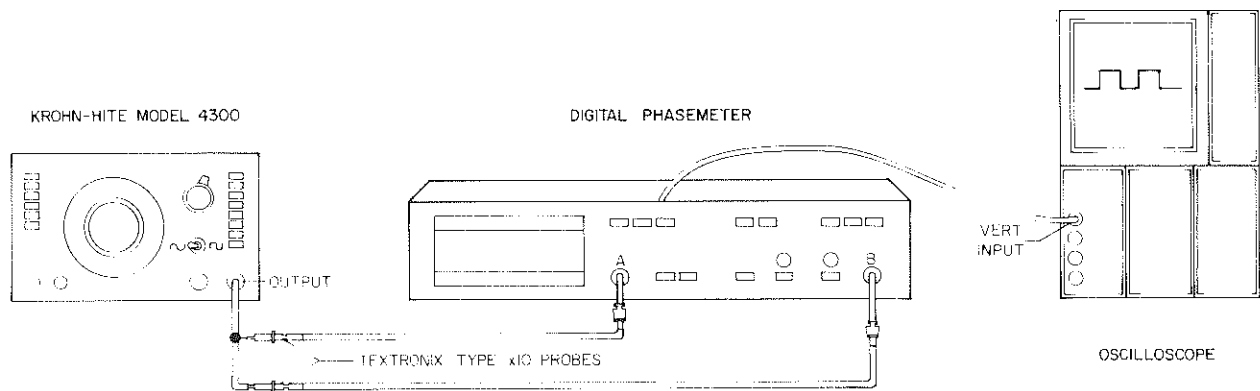

Figure 19. Attenuator Impedance Adjustment Test Set-up

Connect the oscilloscope probe to TP2. Adjust the probe connected to input B for a good square wave on the scope. (A slight ringing is normal).

Switch both input attenuators to 1-12V position. Set generator output to 3V p-p on each phasemeter input. Change the scope vertical to .1 volt/cm, Cal. Connect scope probe to TP7. Adjust C405 for a good square wave. Connect scope probe to TP2. Adjust C205 for a good square wave.

Switch both attenuators to 10-120V position. Set the generator output for 30V p-p. Change the scope vertical to 1 volt/cm Cal. Connect the oscilloscope probe to TP7. Adjust C409 for a good square wave.

Connect the oscilloscope probe to TP2. Adjust C209 for a good square wave. Remove generator, oscilloscope, and X10 probes.

6.3.11 Incorrect Amplitude Indicator Adjust

Connect the main output of the low distortion oscillator to both phasemeter inputs, using matched cables. Set the oscillator frequency to 100 Hz, output amplitude to exactly 0.09 volts RMS. Set both phasemeter input attenuators to 0.1-1.2V positions, waveform switch to \sim . Adjust R477 so that the input A indicator light just goes out. Adjust R273 so that the input B indicator light just goes out.

6.3.12 Phase Vs. Frequency Calibration Check (50 kHz)

Leave the output of the low distortion oscillator connected to both phasemeter inputs. Change the oscillator output to 0.1 volts RMS. Depress the 0° CAL button and readjust the 0° CAL ADJ pot for a meter reading of 000.00° . Depress the 360° CAL button and readjust the 360° CAL ADJ pot for a reading of 360.00° . Depress the 0° CAL button momentarily, then release. Readjust R501 for a reading of 000.00° . Depress the 360° CAL button momentarily, then release. Readjust R490 for a reading of 360.00° .

Change oscillator frequency to 50 kHz, output to 0.3 volts RMS. Depress the 360° CAL button momentarily, then release. Readjust C225 for a reading of 360.00° . Depress the 0° CAL button momentarily, then release. Adjust C647 for a reading of 000.00° . Recheck 360.00° at 50 kHz (C225). Disconnect the low distortion oscillator.

SISTORS

Symbol	Description	Mfr.	Mfr. Part No.
R602	390 10% 1/4W	AB	CB3911
R603	510 5% 1/4W	AB	CB5115
R604	330 10% 1/4W	AB	CB3311
R605	220 10% 1/4W	AB	CB2211
R606	1.1K 5% 1/4W	AB	CB1125
R607	240 5% 1/4W	AB	CB2415
R608	3.3K 10% 1/4W	AB	CB3321
R609	1.2K 10% 1/4W	AB	CB1221
R610	1.2K 10% 1/4W	AB	CB1221
R611	1.1K 5% 1/4W	AB	CB1125
R612	240 5% 1/4W	AB	CB2415
R613	3.3K 10% 1/4W	AB	CB3321
R614	220 10% 1/4W	AB	CB2211
R615	390 10% 1/4W	AB	CB3911
R616	1.2K 10% 1/4W	AB	CB1221
R617	1.2K 10% 1/4W	AB	CB1221
R618	510 5% 1/4W	AB	CB5115
R619	1K 10% 1/4W	AB	CB1021
R630	680 10% 1/4W	AB	CB6811
R631	220 10% 1/4W	AB	CB2211
R632	1K 10% 1/4W	AB	CB1021
R633	562 1% 1/4W	AB	EC5620F
R634	562 1% 1/4W	AB	EC5620F
R635	49.9 1% 1/4W	AB	CC49R9F
R636	680 10% 1/4W	AB	CB6811
R637	2K 5% 1/4W	AB	CB2025
R638	12K 10% 1/4W	AB	CB1231
R639	49.9 1% 1/4W	AB	CC49R9F
R640A	220 10% 1/4W	AB	CB2211
R640B	TRIM	AB	TYPE CB
R641	19K 10% 1/4W	AB	CB1831
R642	10K POT, 0° ADJ	KH	B3304-C
R643	1.33K 1% 1/4W	AB	CC1331F
R644	TRIM	AB	TYPE CB
R645	15.8K 1% 1/8W	TRW	TYPE RH55E*
R646	200Ω 1% 1/8W	AB	CC2003F
R647	500 POT	BKM	72PM
R648	1K 1% 1/4W	AB	CC1001F
R649	10K POT, 360° ADJ	KH	B3304-C
R650	100 10% 1/4W	AB	CB1011
R651	17.8K 1% 1/8W	TRW	TYPE RH55E*
R652	19.6K 1% 1/8W	TRW	TYPE RH55E*
R653	200 POT	BKM	72PM
R654	61.5K 1% 1/8W	AB	CC6152F
R655	3.3K 10% 1/4W	AB	CB3321
R656	TRIM	AB	TYPE CB
R657A	TRIM	AB	TYPE CB
R657B	TRIM	AB	TYPE CB
R658	180Ω 10% 1/4W	AB	CB1841
R659	15K 10% 1/4W	AB	CB1531
R660	TRIM	AB	TYPE CB
R662	27 10% 1/4W	AB	CB2701
R663	100K 10% 1/4W	AB	CB1041
R665	82 10% 1/4W	AB	CB8201
R666	27K 10% 1/4W	AB	CB2731
R671	1K 10% 1/4W	AB	CB1021
R672	432 1% 1/8W	AB	CC4321F
R673	220 10% 1/4W	AB	CB2211
R674	3.3K 10% 1/4W	AB	CB3321
R677	5.6K 10% 1/4W	AB	CB5621
R678	1K 10% 1/4W	AB	CB1021
R679	1K 10% 1/4W	AB	CB1021
R680	220F 5% 1/4W	AB	CB2245
R681	3.3K 10% 1/4W	AB	CB3321

*T.C.: 25 ppm/°C

TRANSISTORS, DIODES & MISC.

Symbol	Description	Mfr.	Mfr. Part No.	Symbol	Description	Mfr.	Mfr. Part No.
Q220	FET, N-CHANNEL	GE	2N4340*				
Q221	TRANSISTOR, NPN	MOT	MPS5656				
Q222	TRANSISTOR, PNP	MOT	MPS5656				
Q223	TRANSISTOR, NPN	MOT	MPS3640				
Q224	TRANSISTOR, PNP	MOT	MPS56518				
Q225	TRANSISTOR, PNP	MOT	MPS56518				
Q260	TRANSISTOR, NPN	TI	T1597				
Q261	TRANSISTOR, NPN	TI	T1597				
Q262	FET, N-CHANNEL	MOT	MPF4392				
Q263	TRANSISTOR, NPN	MOT	MPS2369				
Q264	FET, N-CHANNEL	GE	2N4340				
Q265	TRANSISTOR, NPN	TI	T1597				
Q266	TRANSISTOR, NPN	MOT	MPS3640				
Q267	TRANSISTOR, PNP	MOT	MPS3640				
Q268	TRANSISTOR, NPN	MOT	MPS3646				
Q310	TRANSISTOR, NPN	TI	T1597				
Q311	TRANSISTOR, NPN	MOT	MPS6515				
Q312	TRANSISTOR, PNP	MOT	MPS6518				
Q420	FET, N-CHANNEL	GE	2N4340*				
Q421	TRANSISTOR, NPN	MOT	MPS3640				
Q422	TRANSISTOR, PNP	MOT	MPS5656				
Q423	TRANSISTOR, NPN	MOT	MPS56518				
Q424	TRANSISTOR, PNP	MOT	MPS56518				
Q425	TRANSISTOR, PNP	MOT	MPS56518				
Q460	TRANSISTOR, NPN	TI	T1597				
Q461	TRANSISTOR, NPN	TI	T1597				
Q462	FET, N-CHANNEL	MOT	MPF4392				
Q463	TRANSISTOR, NPN	MOT	MPS2369				
Q464	FET, N-CHANNEL	GE	2N4340				
Q465	TRANSISTOR, NPN	TI	T1597				
Q466	TRANSISTOR, NPN	MOT	MPS3640				
Q467	TRANSISTOR, PNP	MOT	MPS3640				
Q468	TRANSISTOR, NPN	MOT	MPS3646				
Q520	TRANSISTOR, NPN	TI	T1597				
Q521	TRANSISTOR, NPN	MOT	MPS6515				
Q522	TRANSISTOR, PNP	MOT	MPS6518				
Q540	TRANSISTOR, NPN	MOT	2H5087				
Q541	TRANSISTOR, NPN	MOT	MPS6515				
Q542	TRANSISTOR, PNP	MOT	MPS5656				
Q543	FET, N-CHANNEL	MOT	MPF4392				
Q544	TRANSISTOR, PNP	MOT	MPS4448				
Q545	FET, N-CHANNEL	MOT	MPF4392				
Q600	TRANSISTOR, PNP	MOT	MPS3640				
Q601	TRANSISTOR, PNP	MOT	MPS3640				
Q602	TRANSISTOR, PNP	MOT	MPS3640				
Q603	TRANSISTOR, PNP	MOT	MPS3640				
Q630	TRANSISTOR, PNP	MOT	MPS3640				
Q631	TRANSISTOR, PNP	MOT	MPS3640				
Q632	TRANSISTOR, PNP	MOT	MPS3640*				
Q633	FET, N-CHANNEL	MOT	MPF4392				
Q634	TRANSISTOR, NPN	MOT	MPS2369				
Q636	FET, DUAL N-CHANNEL	SIL	SU2366				
Q637	TRANSISTOR, NPN	TI	T1597				
U260	OP AMP	NAT	LM318N				
U310	OP AMP	NAT	LM318N**				
U330	VOLTAGE COMPARATOR	NS	LM306H				
U460	OP AMP	NAT	LM318N				
U520	OP AMP	NAT	LM318N**				
U540	VOLTAGE COMPARATOR	NS	LM306H				
U630	OP AMP	MOT	LM308AN				
CR220	DIODE, SWITCHING	MOT	MPS6515				
CR221	DIODE, SWITCHING	MOT	MPS6515				
CR222	DIODE, SWITCHING	APD	1N4149				
CR223	DIODE, SWITCHING	APD	1N4149				
CR260	DIODE, SWITCHING	APD	1N4149				
CR261	DIODE, SWITCHING	APD	1N4149				
CR262	DIODE, SWITCHING	APD	1N4149				
CR263	DIODE, SWITCHING	APD	1N4149				
CR264	DIODE, SWITCHING	APD	1N4149				
CR265	DIODE, SWITCHING	APD	1N4149				
CR266	DIODE, SWITCHING	APD	1N4149				
CR310	DIODE, SWITCHING, H.C.	MOT	MBD501				
CR311	DIODE, SWITCHING, H.C.	MOT	MBD501				
CR312	DIODE, SWITCHING	APD	1N4149				
CR313	DIODE, SWITCHING	APD	1N4149				
CR420	TRANSISTOR, NPN	MOT	MPS6515				
CR421	TRANSISTOR, NPN	MOT	MPS6515				
CR422	DIODE, SWITCHING	APD	1N4149				
CR423	DIODE, SWITCHING	APD	1N4149				
CR460	DIODE, SWITCHING	APD	1N4149				
CR461	DIODE, SWITCHING	APD	1N4149				
CR462	DIODE, SWITCHING	APD	1N4149				
CR463	DIODE, SWITCHING	APD	1N4149				
CR464	DIODE, SWITCHING	APD	1N4149				
CR465	DIODE, SWITCHING	APD	1N4149				
CR466	DIODE, SWITCHING	FR	FD-3001*				
CR520	DIODE, SWITCHING, H.C.	MOT	MBD501				
CR521	DIODE, SWITCHING, H.C.	MOT	MBD501				
CR522	DIODE, SWITCHING	APD	1N4149				
CR523	DIODE, SWITCHING	APD	1N4149				
CR540	DIODE, SWITCHING	APD	1N4149				
CR541	DIODE, SWITCHING	APD	1N4149				
CR542	DIODE, SWITCHING	APD	1N4149				
CR543	DIODE, SWITCHING	APD	1N4149				
CR544	DIODE, SWITCHING	APD	1N4149				
CR545	DIODE, SWITCHING	APD	1N4149				
CR546	DIODE, SWITCHING	APD	1N4149				
CR547	DIODE, SWITCHING	APD	1N4149				
CR548	DIODE, SWITCHING	APD	1N4149				
CR600	DIODE, SWITCHING	APD	1N4149				
CR601	DIODE, SWITCHING	APD	1N4149				
CR602	DIODE, SWITCHING	APD	1N4149				
CR603	DIODE, SWITCHING	APD	1N4149				
CR630	DIODE, SWITCHING, H.C.	MOT	MBD501				
CR631	DIODE, SWITCHING, H.C.	MOT	MBD501				
CR632	DIODE, SWITCHING	APD	1N4149				
CR633	DIODE, SWITCHING	APD	1N4149				
CR634	DIODE, SWITCHING	APD	1N4149				
CR635	DIODE, SWITCHING, H.C.	MOT	MBD501*				
CR636	DIODE, SWITCHING, H.C.	MOT	MBD501*				
CR637	DIODE, SWITCHING	APD	1N4149				
CR639	DIODE, SWITCHING	APD	1N4149				
CR640	DIODE, SWITCHING	APD	1N4149				
VR331	DIODE, ZENER, 9V	APD	1N937				
VR546	DIODE, ZENER, 9V	APD	1N937				
L220	5.6uH 10% 1/4W	DLV	1537-3C				
L221	5.6uH 10% 1/4W	DLV	1537-3C				
L222	5.6uH 10% 1/4W	DLV	1537-3C				
L224	5.6uH 10% 1/4W	DLV	1537-3C				
L225	1uH 10% 1/4W	DLV	1537-12				
L330	5.6uH 10% 1/4W	DLV	1537-3I				
L331	47uH 10% 1/4W	DLV	1537-6I				
L420	5.6uH 10% 1/4W	DLV	1537-3I				
L421	5.6uH 10% 1/4W	DLV	1537-3I				
L422	5.6uH 10% 1/4W	DLV	1537-3I				
L425	5.6uH 10% 1/4W	DLV	1537-3				
L426	1uH 10% 1/4W	DLV	1537-1				
L540	5.6uH 10% 1/4W	DLV	1537-3				
L541	47uH 10% 1/4W	DLV	1537-6				
L630	5.6uH 10% 1/4W	DLV	1537-3				
L631	100uH 10% 1/4W	DLV	3500-0				
L632	22uH 10% 1/4W	DLV	1537-4				
DS201	LIGHT INDICATOR, SET RANGE	DIA	2-559-				
DS401	LIGHT INDICATOR, SET RANGE	DIA	2-559-				
S201	SWITCH, PUSHBUTTON, RMS	KH	Part #B329C				
S401	SWITCH, PUSHBUTTON, RMS	KH					
S601	SWITCH, PUSHBUTTON, 0° CAL	ZH	Part #B330				
S602	SWITCH, PUSHBUTTON, 360° CAL	KH					
S701	SWITCH, PUSHBUTTON, WAVEFORM	KH	Part #B332C				

NOTES:

*Q220, Q240 selected for 0.7V ≤ Vgs, 1.1V ≤ Id = 400uA, and for Vgs matching ± 200 uV.

* Q632 selected for ΔVf ≤ 3mV @ { 10uA ≤ If ≤ 10mA }
 -55°C ≤ TA ≤ 100°C

†HC = HOT CARRIER.

‡VR466 selected for IR ≤ 1mA @ VR = 125V.

§CR635, CR636 T.C. matched within 5uV/°C, plus thermal clamping.

** SELECTED FOR LOW NOISE

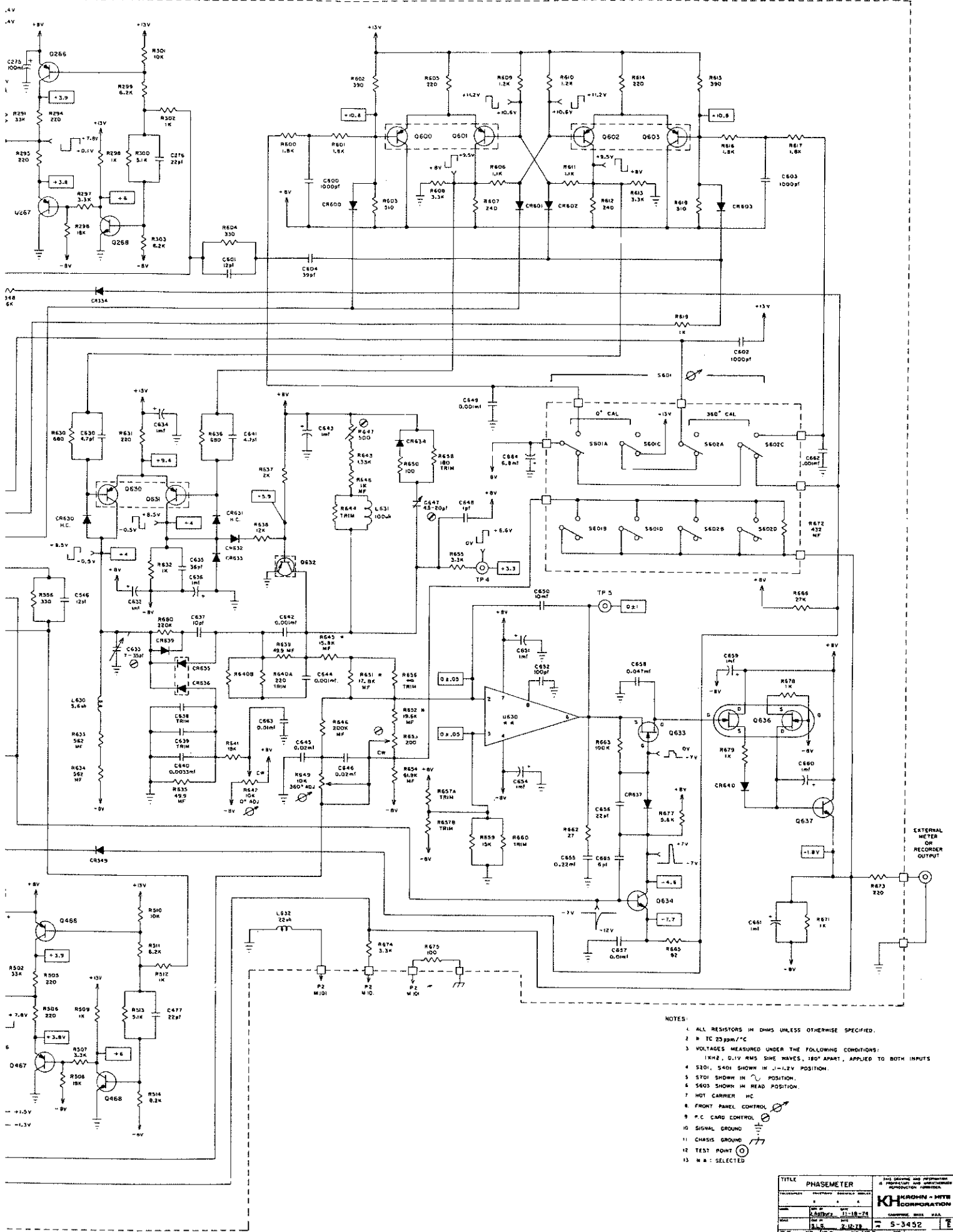

- NOTES:
1. ALL RESISTORS IN OHMS UNLESS OTHERWISE SPECIFIED.
 2. R = TC 25 ppm/°C
 3. VOLTAGES MEASURED UNDER THE FOLLOWING CONDITIONS:
 1 KW, 0.1V RMS SINE WAVES, 180° APART, APPLIED TO BOTH INPUTS
 4. S201, S401 SHOWN IN \downarrow POSITION.
 5. S701 SHOWN IN \downarrow POSITION.
 6. S603 SHOWN IN READ POSITION.
 7. HOT CARRIER HC
 8. FRONT PANEL CONTROL
 9. * C CARD CONTROL
 10. SIGNAL GROUND
 11. CHASSIS GROUND
 12. TEST POINT
 13. M = SELECTED

TITLE		PHASEMETER	
DESIGNER	DATE	REVISED	BY
11-18-74			
DRAWN		5-3452	
DATE		4/5/83	
JOB NO.		1044388	
PAGE		1	

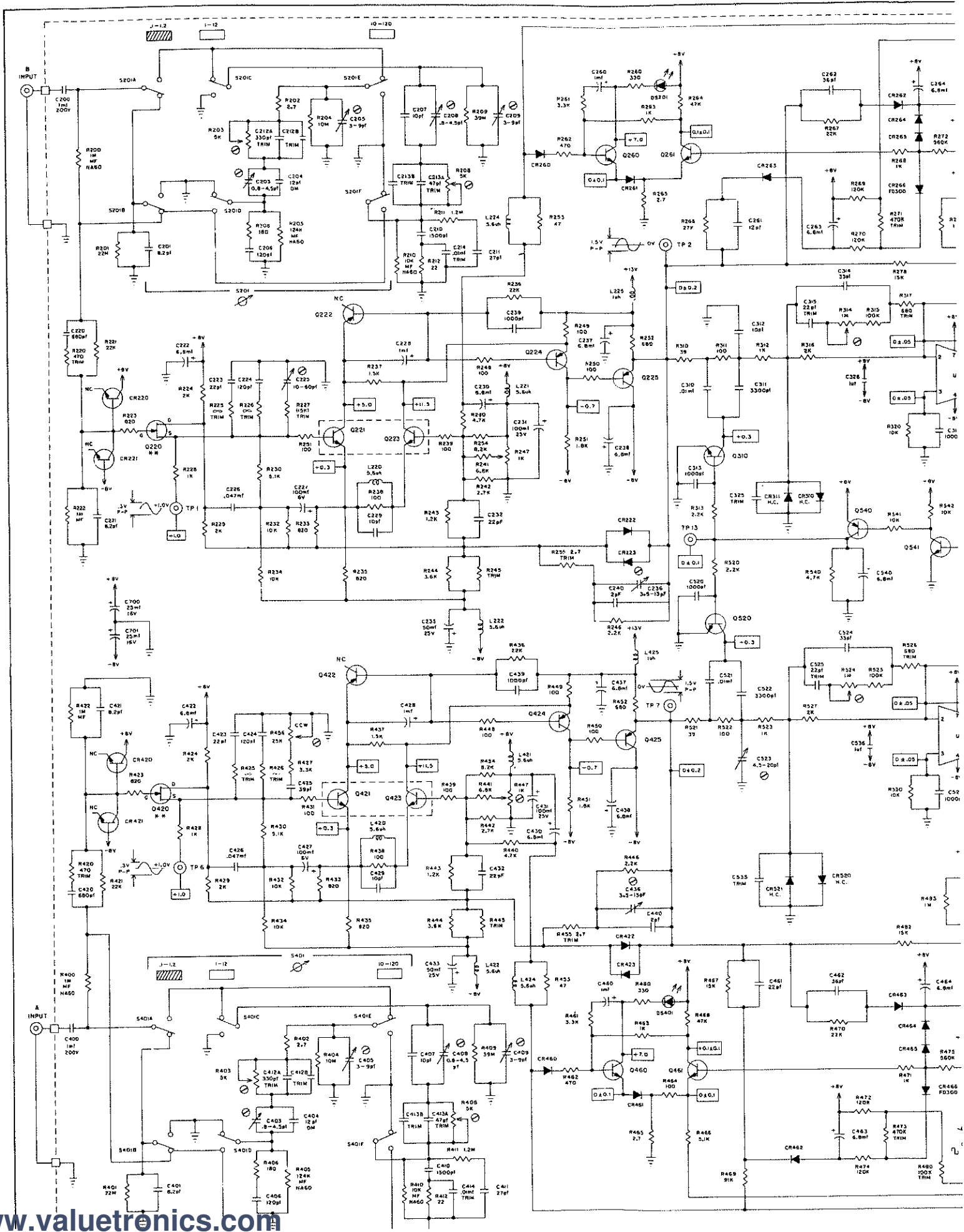

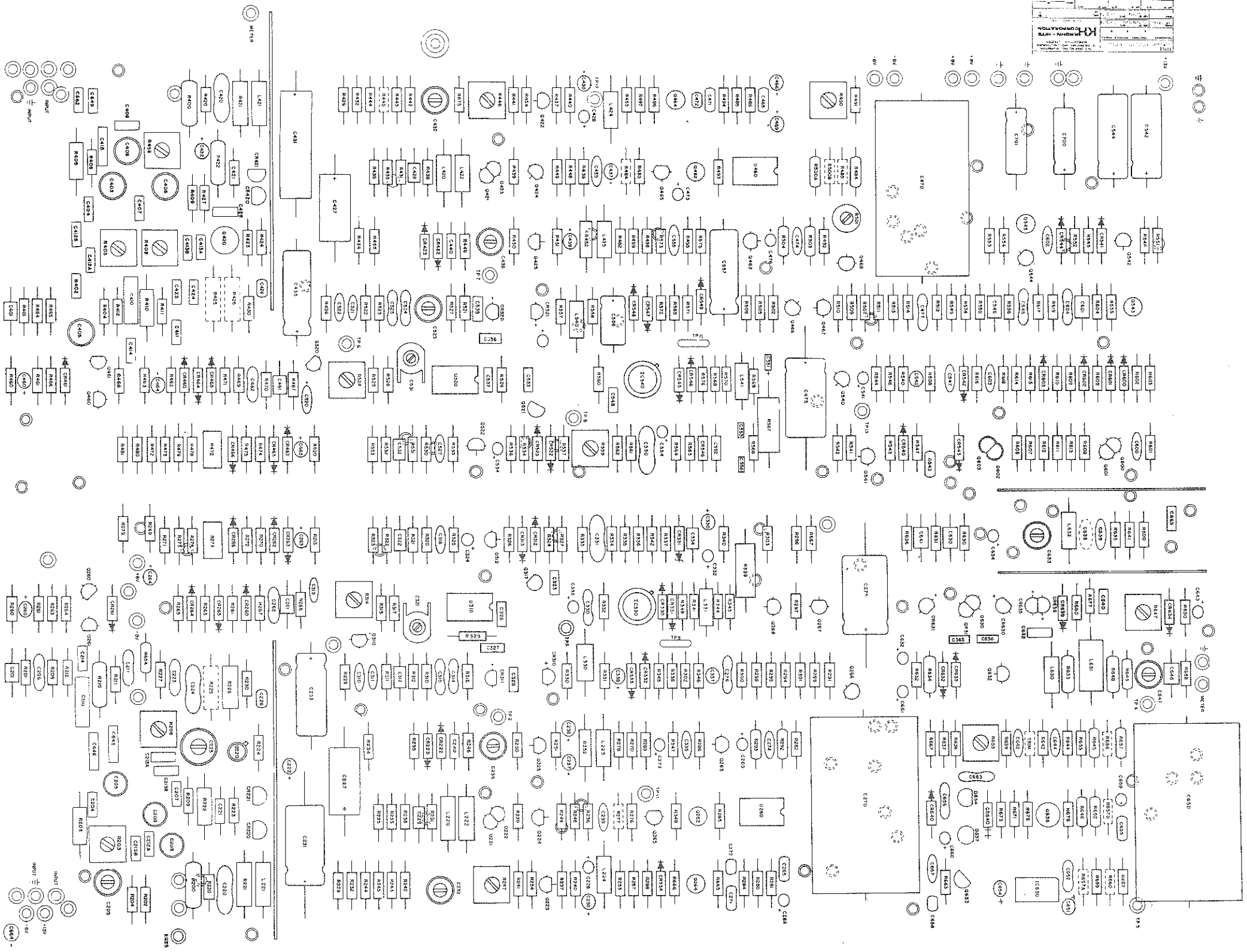

PC 601

4/5/83 C.O.#4388

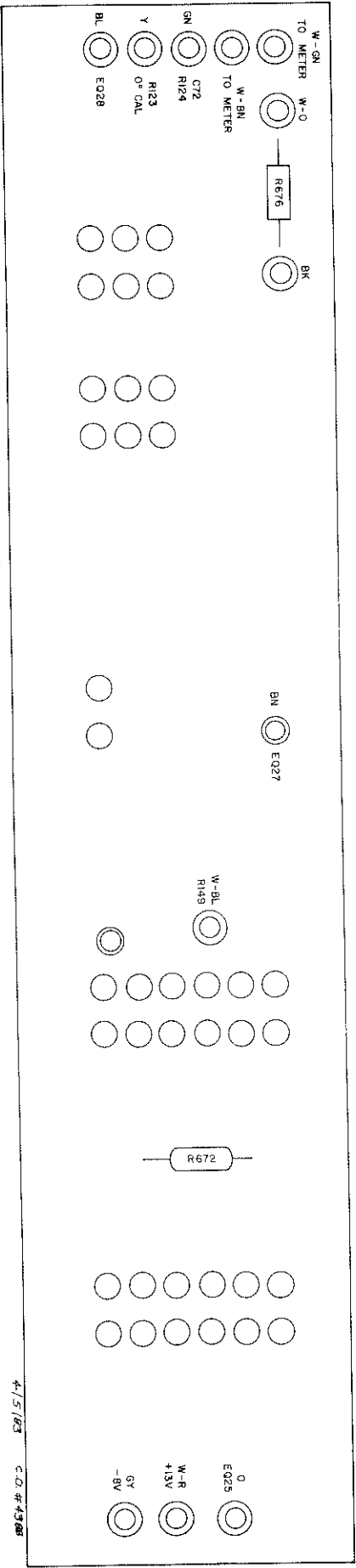

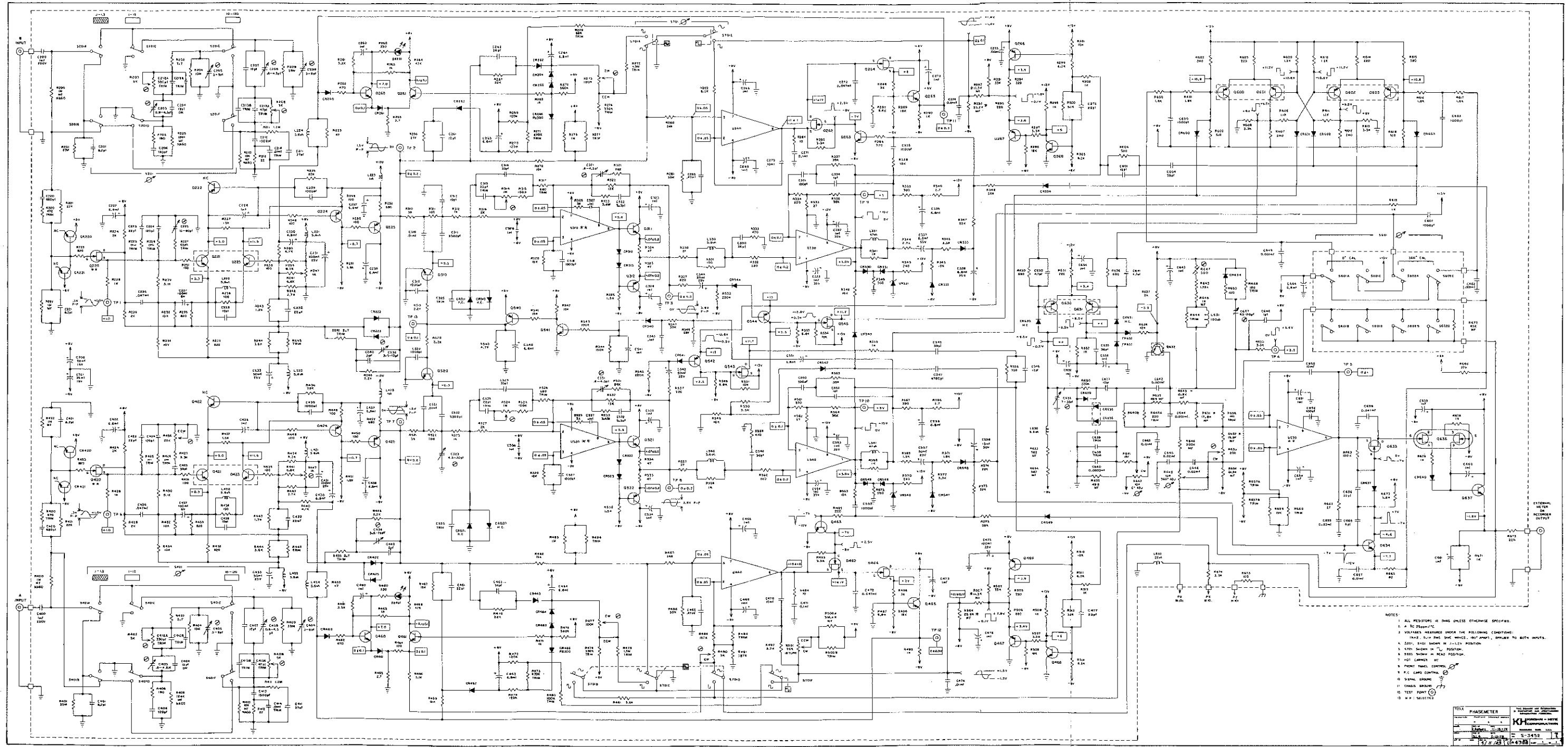

- NOTES:
1. ALL RESISTORS IN OHMS UNLESS OTHERWISE SPECIFIED.
 2. A. 500K/100K.
 3. VOLTAGE MEASURED UNDER THE FOLLOWING CONDITIONS:
 (1) 2.5V RMS 500 Hz SINUSOIDAL INPUT, APPLIED TO BOTH INPUTS.
 (2) 500 Hz SINUSOIDAL INPUT IN POSITION.
 (3) 500 Hz SINUSOIDAL INPUT IN READ POSITION.
 (4) 500 Hz SINUSOIDAL INPUT IN READ POSITION.
 4. POINT TO BE CONTROLLED.
 5. P.C. CARD CONTROL.
 6. VERNIER CONTROL.
 7. CHASSIS GROUND.
 8. TEST POINT.
 9. N.P. SELECTED.

PHASEMETER	
Model	1000
Serial No.	1000
Part No.	1000
Rev.	1000
Printed in U.S.A.	

DC C22

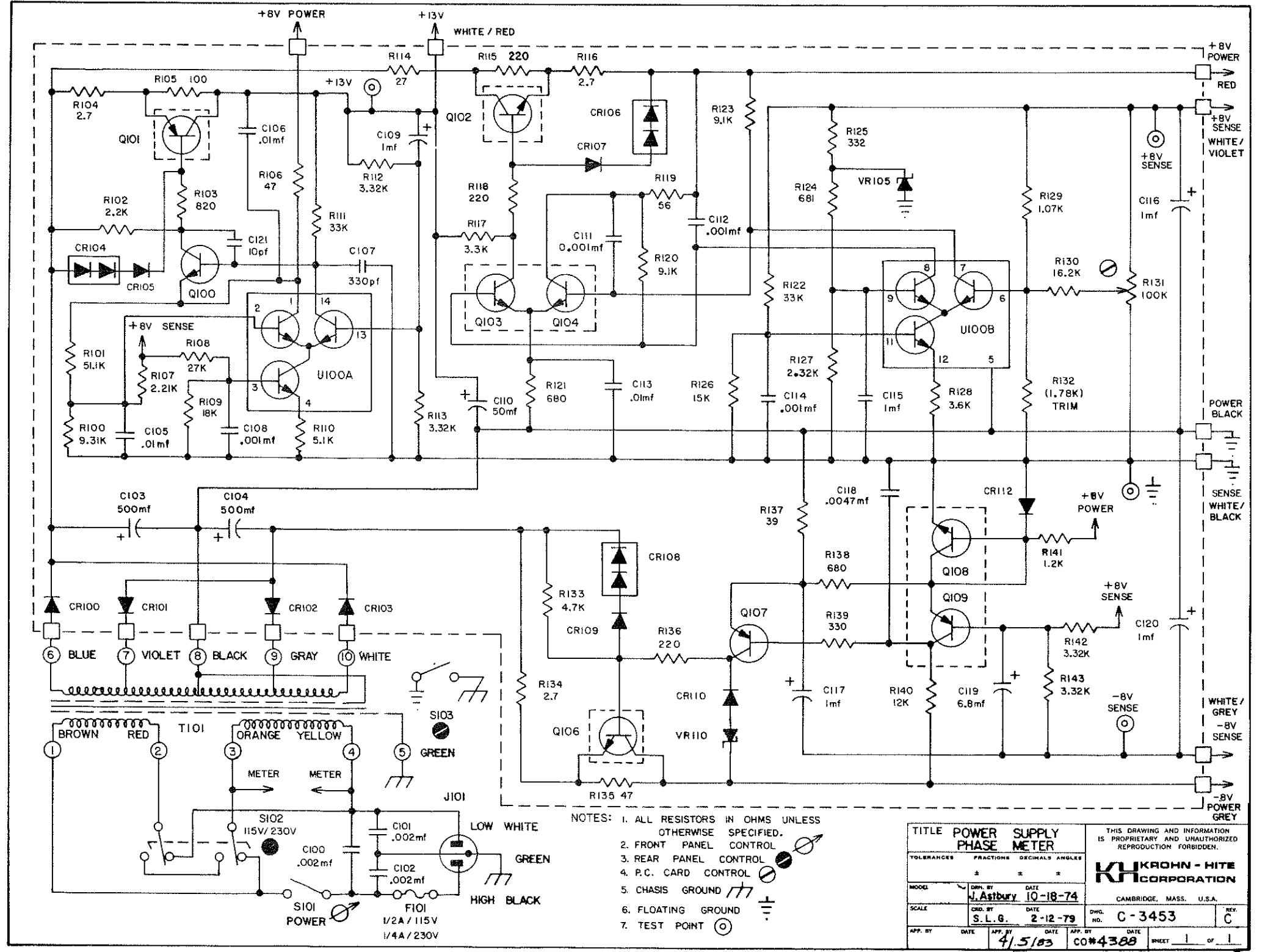
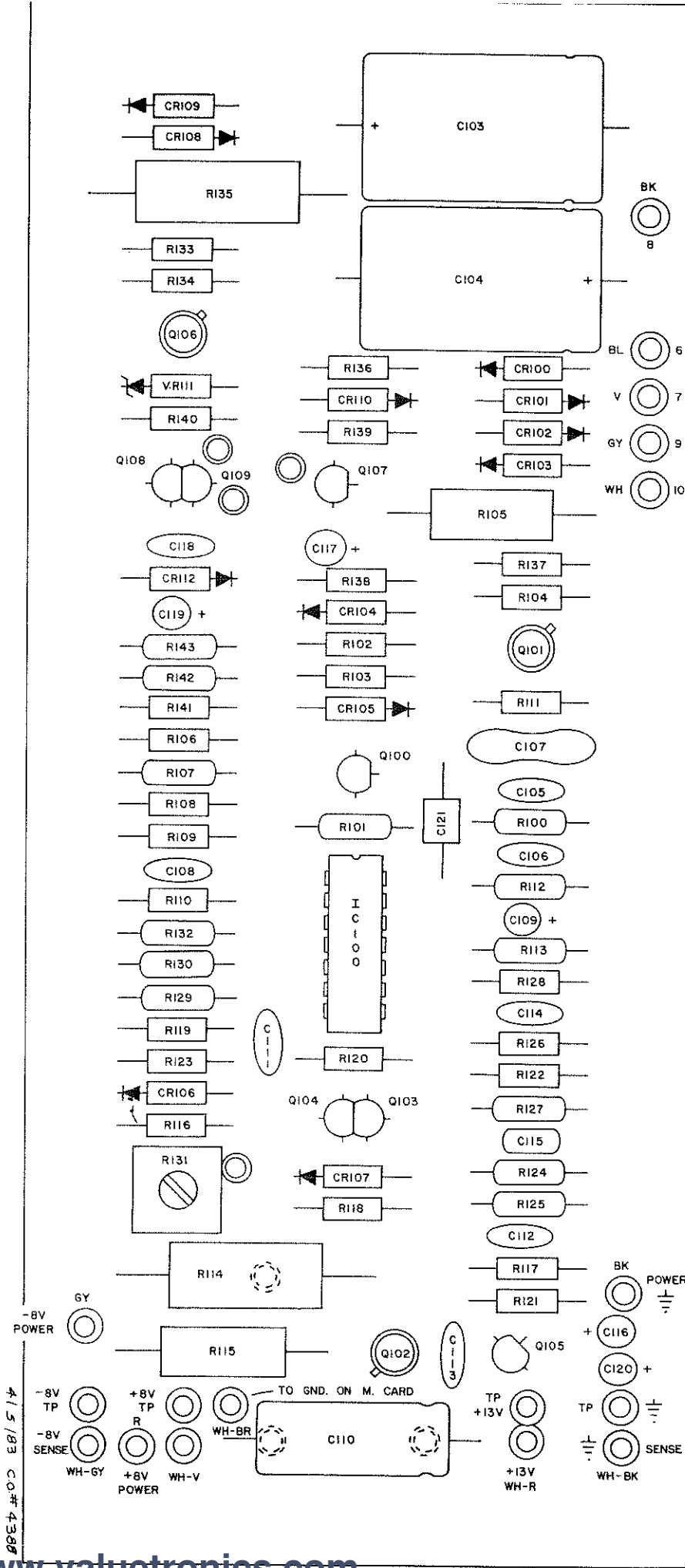

- NOTES:
1. ALL RESISTORS IN OHMS UNLESS OTHERWISE SPECIFIED.
 2. FRONT PANEL CONTROL
 3. REAR PANEL CONTROL
 4. P.C. CARD CONTROL
 5. CHASSIS GROUND
 6. FLOATING GROUND
 7. TEST POINT

TITLE POWER SUPPLY PHASE METER		THIS DRAWING AND INFORMATION IS PROPRIETARY AND UNAUTHORIZED REPRODUCTION FORBIDDEN.	
TOLERANCES	FRACTIONS	DECIMALS	ANGLES
MODEL	DRN. BY J. Astbury	DATE 10-18-74	
SCALE	DRN. BY S.L.G.	DATE 2-12-79	DWG. NO. C-3453
APP. BY	DATE 4/5/83	APP. BY	DATE
CO#4388		SHEET 1 OF 1	

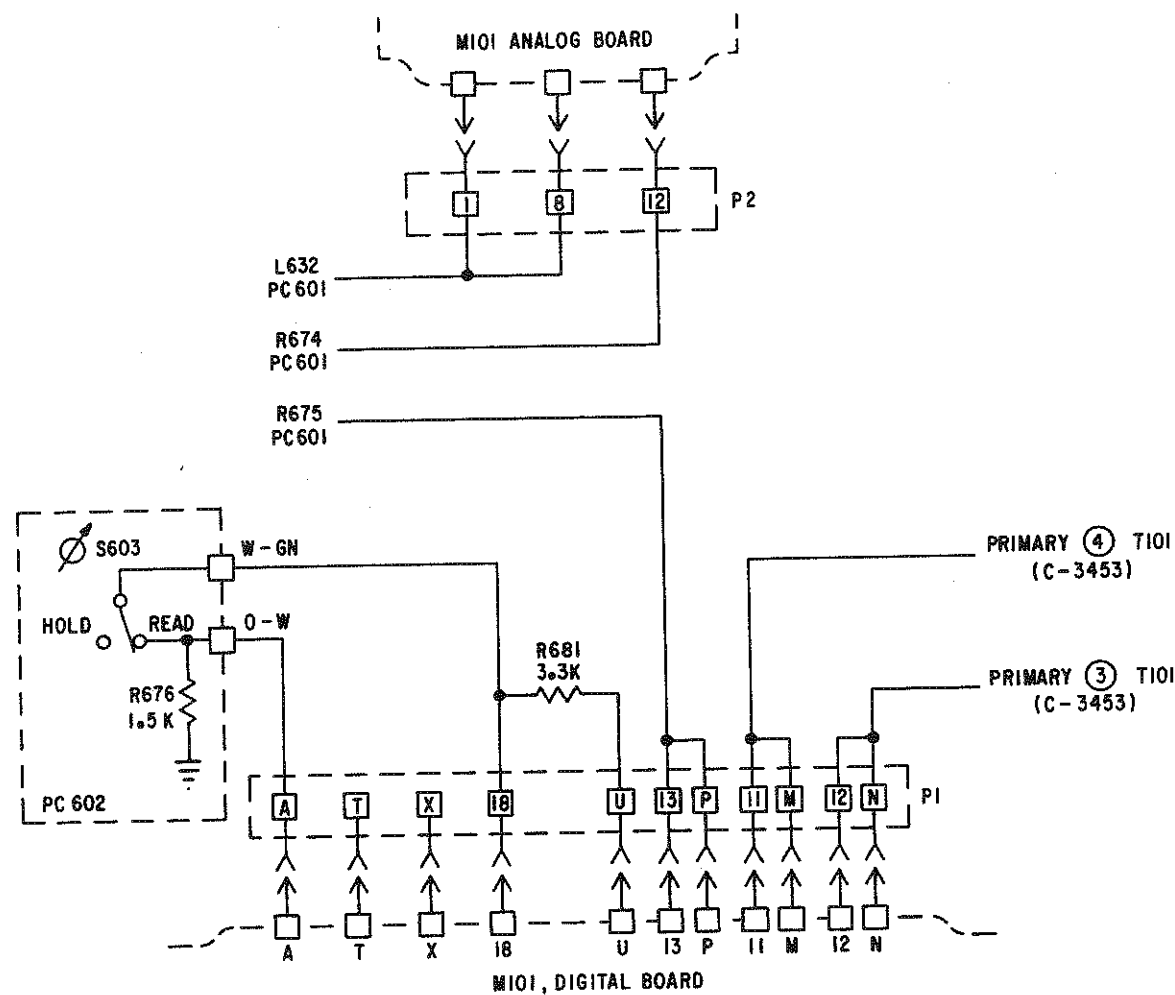

TITLE DIGITAL PANEL METER		THIS DRAWING AND INFORMATION IS PROPRIETARY AND UNAUTHORIZED REPRODUCTION FORBIDDEN.	
TOLERANCES FRACTIONS DECIMALS ANGLES		 AVON, MASS. U.S.A.	
± ± ±			
MODEL	DRN. BY J. Asterbury	DATE 3-7-79	
SCALE	CKD. BY S. Quinta	DATE 3-7-79	DWG. NO. M101
APP. BY	DATE	APP. BY	DATE
SHEET _____ OF _____			

RESISTORS											
Symbol	Description			Mfr.	Mfr. Part No.	Symbol	Description			Mfr.	Mfr. Part No.
R100	9.31K	1%	1/4W	AB	CC9311F	R124	681	1%	1/4W	AB	CC6815F
R101	51.1K	1%	1/4W	AB	CC5112F	R125	332	1%	1/4W	AB	CC3320F
R102	2.2K	10%	1/4W	AB	CB2221	R126	15K	10%	1/4W	AB	CB1531
R103	820	10%	1/4W	AB	CB8211	R127	2.32K	1%	1/4W	AB	CC2321F
R104	2.7	10%	1/4W	AB	CB2761	R128	3.6K	5%	1/4W	AB	CB3625
R105	100	10%	1W	AB	GB1011	R129	1.07K	1%	1/4W	AB	CC1071F
R106	47	10%	1/4W	AB	CB4701	R130	16.2K	1%	1/4W	AB	CC1622F
R107	2.21K	1%	1/4W	AB	CC2211F	R131	100K POT			BKM	72PM
R108	27K	10%	1/4W	AB	CB2731	R132	1.78K	1%	1/4W	AB	CC1781F
R109	18K	10%	1/4W	AB	CB1831	R133	4.7K	10%	1/4W	AB	CB4721
R110	5.1K	5%	1/4W	AB	CB5125	R134	2.7	10%	1/4W	AB	CB27G1
R111	33K	10%	1/4W	AB	CB3331	R135	39	10%	2W	AB	HB3901
R112	3.32K	1%	1/4W	AB	CC3321F	R136	220	10%	1/4W	AB	CB2211
R113	3.32K	1%	1/4W	AB	CC3321F	R137	39	10%	1/4W	AB	CB3901
R114	27	10%	2W	AB	GB2701	R138	680	10%	1/4W	AB	CB6811
R115	220	10%	1W	AB	GB2211	R139	330	10%	1/4W	AB	CB3311
R116	2.7	10%	1/4W	AB	CB27G1	R140	12K	10%	1/4W	AB	CB1231
R117	3.3K	10%	1/4W	AB	CB3321	R141	1.2K	10%	1/4W	AB	CB1221
R118	220	10%	1/4W	AB	CB2211	R142	3.32K	1%	1/4W	AB	CC3321F
R119	56	10%	1/4W	AB	CB5601	R143	3.32K	1%	1/4W	AB	CC3321F
R120	9.1K	5%	1/4W	AB	CB9125						
R121	680	10%	1/4W	AB	CB6811						
R122	33K	10%	1/4W	AB	CB3331						
R123	9.1K	5%	1/4W	AB	CB9125						
R676	1.5K	10%	1/4W	AB	CB1521						
R681	3.3K	10%	1/4W	AB	CB3321						

CAPACITORS											
Symbol	Description			Mfr.	Mfr. Part No.	Symbol	Description			Mfr.	Mfr. Part No.
C100	0.002uf	20%	1000V	SP	C0238102F202M	C111	0.001uf	20%	500V	SP	C0238501E102M
C101	0.002uf	20%	1000V	SP	C0238102F202M	C112	0.001uf	20%	500V	SP	C0238501E102M
C102	0.002uf	20%	1000V	SP	C0238102F202M	C113	0.01uf	20%	100V	SP	C0238501G103M
C103	500uf	+75%-10%	25V	MAL	TT501N02561A1P	C114	0.001uf	20%	500V	SP	C0238501E102M
C104	500uf	+75%-10%	25V	MAL	TT501N02561A1P	C115	1uf	+80%-20%	25V	SP	50C02310508250B3
C105	0.01uf	20%	100V	SP	C0238501G103M	C116	1uf	20%	35V	SP	196D105X0035HA1
C106	0.01uf	20%	100V	SP	C0238501G103M	C117	1uf	20%	35V	SP	196D105X0035HA1
C107	330pf	5%	500V	ELM	DM15C331J	C118	0.0047uf	20%	500V	SP	C0238501F472M
C108	0.001uf	20%	500V	SP	C0238501E102M	C119	6.8uf	20%	35V	SP	196D685X0035FB
C109	1uf	20%	35V	SP	196D105X0035HA1	C120	1uf	20%	35V	SP	196D105X0035HA1
C110	50uf	+75%-10%	25V	SP	30D5066025CC4	C121	10pf	10%	500V	ASP	9213-10110

SEMICONDUCTORS & MISC.											
Symbol	Description			Mfr.	Mfr. Part No.	Symbol	Description			Mfr.	Mfr. Part No.
Q100	TRANSISTOR, NPN			MOT	MPS6515	VR105	DIODE, ZENER, 6.4V			NS	1N4577A
Q101	TRANSISTOR, PNP			MOT	2N2955A	VR110	DIODE, ZENER, 6.8V			APD	1N957B
Q102	TRANSISTOR, NPN			MOT	2N2219A	F101	FUSE, SLOW BLOW, 115VAC			BUS	MDL-.5A
Q103	TRANSISTOR, NPN			MOT	MPS6515		FUSE, SLOW BLOW, 230VAC			BUS	MDL-.25A
Q104	TRANSISTOR, NPN			MOT	MPS6515	J101	RECEPTACLE, AC POWER			SWC	EAC-301
Q106	TRANSISTOR, NPN			MOT	2N2219A	M101	METER, DIGITAL			NP	2000AS-2
Q107	TRANSISTOR, PNP			MOT	2N5087	P1	CONNECTOR, MALE, DPM			TRW	250-22-30-270
Q108	TRANSISTOR, NPN			MOT	2N5225*	P2	CONNECTOR, MALE, DPM			TRW	250-15-30-170
Q109	TRANSISTOR, PNP			MOT	2N5087*		ANALOG BOARD				
CR100	DIODE, RECTIFIER, 100PIV			ITT	1N4002	[S101]	[SWITCH, PUSHBUTTON, POWER]			[KH]	[Part of Assy.]
CR101	DIODE, RECTIFIER, 100PIV			ITT	1N4002	[S603]	[SWITCH, PUSHBUTTON, READ/HOLD]			[KH]	[B3301-B]
CR102	DIODE, RECTIFIER, 100PIV			ITT	1N4002	S102	SWITCH, SLIDE, LINE			SWC	46256LFR
CR103	DIODE, RECTIFIER, 100PIV			ITT	1N4002	S103	SWITCH, SLIDE, GROUND			CW	GF-123
CR104	DIODE, DUAL			MOT	MZ2361	T101	TRANSFORMER, POWER			KH	82975-E
CR105	DIODE, SWITCHING			APD	1N4149						
CR106	DIODE, DUAL			MOT	MZ2361						
CR107	DIODE, SWITCHING			APD	1N4149						
CR108	DIODE, DUAL			MOT	MZ2361						
CR109	DIODE, SWITCHING			APD	1N4149						
CR110	DIODE, SWITCHING			APD	1N4149						
CR112	DIODE, SWITCHING			APD	1N4149						
U100	TRANSISTOR ARRAY			RCA	CA3054						

*Q108, Q109 physically clamped to cancel thermal drift.

MANUFACTURERS CODE							
AB	(01121)	Allen Bradley Company	Milwaukee, WI	GE	(03508)	General Electric	Syracuse, NY
APD	(50273)	American Power Devices	Andover, MA	ITT	()	ITT Semiconductor	Woburn, MA
ASP	(82142)	Airco Speer	Dubois, PA	MAL	(37942)	P. R. Mallory & Co.	Indianapolis, IN
BKM	(30646)	Beckman Instrument Co.	Cedar Grove, NJ	MOT	(04713)	Motorola Semiconductor	Phoenix, AZ
BRN	()	Bourns, Inc.	Riverside, CA	NP	(32873)	Newport Labs., Inc.	Santa Anna, CA
BUS	(71400)	Bussman Mfg. Co.	St. Louis, MO	NS	(36462)	National Semiconductor	Plattsburgh, NY
CD	(88419)	Cornell-Dubilier	Newark, NJ	RCA	(49671)	Radio Corporation of America	Harrison, NJ
CGW	(14674)	Corning Glass Works	Corning, NY	SIL	(17856)	Siliconix	Sunnyvale, CA
COD	(16352)	Computer Diode Corp.	Fairlawn, NJ	SP	(56289)	Sprague Electric	North Adams, MA
CH	(79727)	C.W. Industries	Harminster, PA	STT	()	Stettner-Trush, Inc.	Cazenovia, NY
DIA	()	Dialight Corp.	Brooklyn, NY	SWC	(82389)	Switchcraft, Inc.	Chicago, IL
DLV	(99800)	DeLevan Electronics	East Aurora, NY	TI	(02195)	Texas Instruments, Inc.	Dallas, TX
ELM	(72136)	Electro-Motive Mfg. Co.	Williamantic, CN	TR	(03877)	Transitron Electric Co.	Wakefield, MA
ERT	(72982)	Erie Technological Prod.	Erie, PA	TRW	(84411)	TRW Capacitor Div.	Ogallala, NB
FR	(07263)	Fairchild Semiconductor	San Rafael, CA				