

**DIGITALLY TUNED  
VARIABLE FILTER**

**3320 SERIES**

**MODEL NO. \_\_\_\_ SERIAL NO. \_\_\_\_**

**OPERATING AND MAINTENANCE  
MANUAL**



**KROHN-HITE CORPORATION**

AVON INDUSTRIAL PARK/BODWELL STREET/AVON, MASS. 02322

© 1978 KROHN-HITE CORPORATION

Printed in U.S.A., April, 1981

## CONTENTS

Section	Page
1 GENERAL DESCRIPTION .....	1
2 OPERATING INSTRUCTIONS .....	8
3 CIRCUIT DESCRIPTION .....	14
4 MAINTENANCE .....	18
5 CALIBRATION AND ADJUSTMENT .....	23

## ILLUSTRATIONS

Figure	Page
1 Models 3320 and 3323 Filters .....	ii
2 Multifunction Response Characteristics .....	5
3 Filter Response to Square Wave Input .....	5
4 Normalized Attenuation Characteristics .....	6
5 Normalized Phase Characteristics .....	7
6 Controls and Connections .....	9
7 Installation of Batteries .....	12
8 Simplified Schematic Diagram in Low-Pass .....	15
9 Simplified Schematic Diagram in High-Pass .....	15
10 Typical Quadratic Amplifier Shown in High-Pass .....	16
11 Schematic, Parts List, and Printed Circuit Layout .....	Inside Back Cover

## TABLES

Table	Page
1 Test Points for Low-Pass and High-Pass Operation .....	19
2 Detailed Test Procedure .....	26

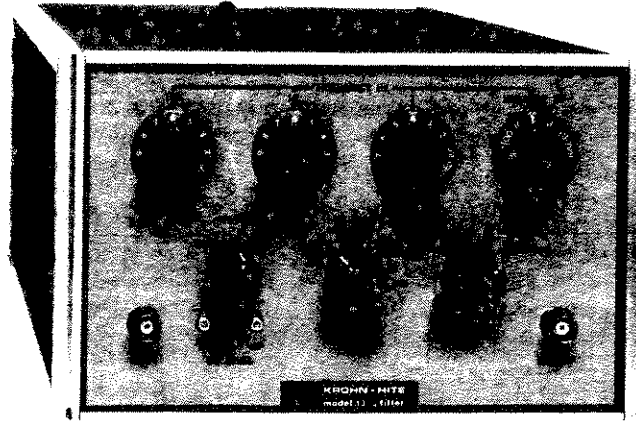

Model 3320

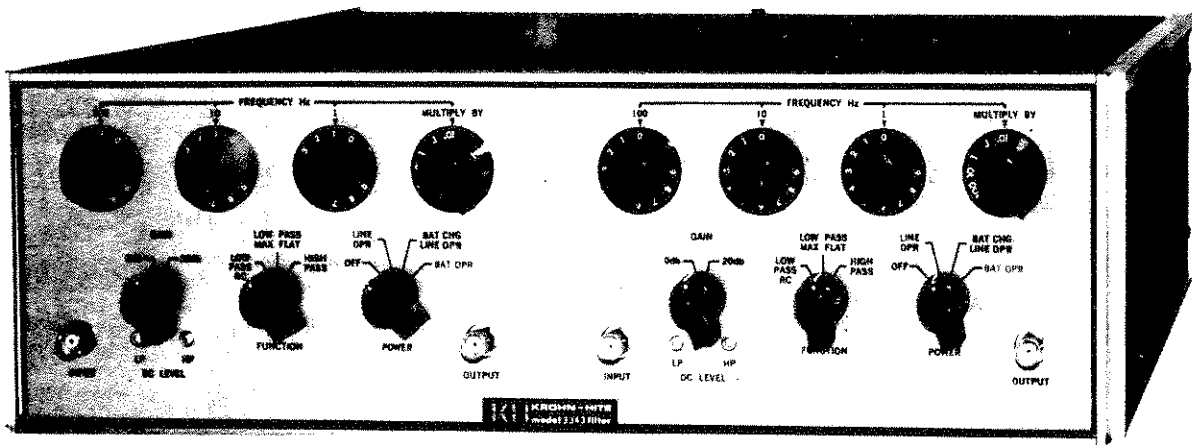

Model 3323

Figure 1. Models 3320 and 3323 Filters

## SECTION 1

# GENERAL DESCRIPTION

### 1.1 INTRODUCTION

This manual provides operation and maintenance instructions, with detailed specifications, schematic diagram and parts list, for the Models 3320, 3321, 3322 and 3323 digitally tuned Filters, illustrated in Figure 1. An optional Rack-Mounting Kit (Part No. RK-58 for Models 3320/3321; Part No. RK-519 for Models 3322/3323) is available for installing the Filter into a standard, 19" rack spacing.

Reference to Operating Instructions, Section 2, is recommended before these Filters are put into operation. In the event the Filters are not functioning or fail to meet performance specifications, reference should be made to Maintenance, Section 4. However, before doing any troubleshooting, it should be determined if the normal adjustments mentioned in the Calibration & Adjustment Procedure, Section 5, will correct the trouble.

The Models 3320, 3321, 3322 and 3323 Filters illustrated in Figure 1, are variable, electronic Filters with digitally tuned cutoff frequencies. The Models 3320 and 3322 have a cutoff frequency range from 0.001 Hz to 99.9 kHz. The Models 3321 and 3323 are tunable over the range from 0.01 Hz to 99.9 kHz. The pass-band gain is unity (0db) or 10 (20db), with attenuation rates of 24db per octave outside the pass-band. Maximum attenuation is greater than 80db and the output hum and noise is less than 500 microvolts. The Model 3320 (Model 3321) can function as either a High-Pass or Low-Pass Filter. In the High-Pass mode of operation the maximum input signal is plus or minus 7 volts peak in the 0db gain position, plus or minus 0.7 volts peak in the 20db gain position, and the upper 3db point occurs at approximately 1 MHz. In the Low-Pass mode the Filter is direct-coupled and the combined ac plus dc input signal should not exceed  $\pm 7$  volts peak in the 0db gain position and  $\pm 0.7$  volts peak in the 20db gain position.

The Model 3322 (Model 3323) consists of two of the Model 3320 (Model 3321) mounted in a single cabinet isolated from each other, with independent power supplies and input and output connectors. When these two filter channels are switched to the same mode of operation and cascaded, with both channels set to the same cutoff frequency, the Model 3322 (Model 3323) will function as a High-Pass or Low-Pass Filter with an attenuation rate of 48db per octave. If the two channels are connected in series, and one channel is operated in the Low-Pass mode and the other channel in the High-Pass mode, the Model 3322 (Model 3323) will function as a Band-Pass Filter with an attenuation rate of 24db per octave outside the pass-band. When the two channels are connected in parallel, as described in Section 2.3, the Model 3322 (Model 3323) will function as either a Band-Reject Filter with cutoff frequency limits from 0.001 Hz to 99.9 kHz (0.01 Hz to 99.9 kHz - Model 3323) or provide a null at any frequency between 0.01 Hz and 10 kHz (0.1 Hz and 10 kHz - Model 3323).

The Filter has a maximally flat (Butterworth) characteristic when the FUNCTION switch(s) is in the Low-Pass MAX FLAT position. For pulse-type wave-forms this switch should be in the Low-Pass RC (Low Q) position, optimum for transient-free filtering.

1.2 SPECIFICATIONS

(Specifications in [ ] apply to Models 3321/3323).

Frequency Range

Models 3320 and 3322

High-Pass and Low-Pass cutoff frequencies continuously adjustable from 0.001 Hz to 99.9 kHz in six bands.

<u>BAND</u>	<u>MULTIPLIER</u>	<u>FREQUENCY (Hz)</u>	<u>RESOLUTION</u>
1	0.001	0.001 - 0.999	0.001
2	0.01	1 - 9.99	0.01
3	0.1	10 - 99.9	0.1
4	1	100 - 999	1
5	10	1,000 - 9,990	10
6	100	10,000 - 99,900	100

Models 3321 and 3323

High-Pass and Low-Pass cutoff frequencies continuously adjustable from 0.01 Hz to 99.9 kHz, in 5 bands.

<u>BAND</u>	<u>MULTIPLIER</u>	<u>FREQUENCY (Hz)</u>	<u>RESOLUTION</u>
1	0.01	0.01 - 9.99	0.01
2	0.1	10 - 99.9	0.1
3	1	100 - 999	1
4	10	1,000 - 9,990	10
5	100	10,000 - 99,900	100

Frequency Control (each channel)

Three rotary decade switches for frequency digits and a 6 [ 5 ] position rotary multiplier switch.

Cutoff Frequency Calibration Accuracy

±2% from 0.05 Hz to 9.99 kHz, rising to ±10% at 0.001 Hz [0.01 Hz] (less accurate in High-Pass mode at 0.001 Hz [0.01 Hz]), ±10% from 10.0 kHz to 99.9 kHz (X100 Band). Relative to mid-band level, the filter output is down 3db at cutoff in the Butterworth (maximally flat) position and approximately 15db down when operated as a Low-Pass Filter in RC (transient-free) position.

Bandwidth

Low-Pass Mode: DC to cutoff frequency setting within the range from 0.001 Hz [0.01 Hz] to 99.9 kHz.

High-Pass Mode: Cutoff frequency setting within the range of 0.001 [0.01 Hz] and 99.9 kHz to the upper 3db point of approximately 1 MHz.

Band-Pass Operation (Models 3322, 3323): Variable within the cutoff frequency limits of 0.001 Hz [0.01 Hz] to 99.9 kHz. For minimum bandwidth, the High-Pass and Low-Pass cutoff frequencies are set equal. This produces an insertion loss of approximately 6db, with the minus 3db points at 0.8 and 1.25 times the midband frequency.

Band-Reject Operation (Models 3322, 3323): Variable within the cutoff frequency limits of 0.001 Hz [0.01 Hz] and 99.9 kHz. The Low-Pass band extends to dc and the High-Pass band has its upper 3 db point at approximately 1 MHz.

**Response Characteristics**

Butterworth: Maximally flat, four pole Butterworth response for optimum performance in frequency domain.

RC: Four pole damped response for transient-free time-domain performance.

**Attenuation Slope**

Nominal 24 db per octave per channel in Low-Pass or High-Pass mode.

**Maximum Attenuation**

Greater than 80 db for input frequencies to 100 kHz, rising to 60 db at 1 MHz.

**Pass-Band Gain (selected by front panel control)**

$0 \pm 0.5$  db or  $20 \pm 0.5$  db for bands 2 through 5 [1 thru 4],  $0 \pm 1$  db or  $20 \pm 1$  db for bands 1 and 6 [5].

**Input Characteristics**

$\pm 7$  volts peak in the 0 db gain position,  $\pm 0.7$  volts peak in the 20 db gain position to 500 kHz, decreasing to  $\pm 3$  volts peak ( $\pm 0.3$  volts peak in the 20 db gain position) at 1 MHz.

Maximum DC Component Low-Pass Mode: Combined ac plus dc should not exceed  $\pm 7$  volts peak in the 0 db gain position and  $\pm 0.7$  volts peak in the 20 db gain position.

Maximum DC Component High-Pass Mode:  $\pm 100$  volts.

Impedance: 10 megohms in parallel with 100 pF.

**Output Characteristics**

Maximum Voltage:  $\pm 7$  volts peak to 500 kHz decreasing to  $\pm 3$  volts peak at 1 MHz, open circuit.

Maximum Current:  $\pm 70$  ma peak to 500 kHz decreasing to 30 ma peak at 1 MHz.

Impedance: 50 ohms.

Distortion: Typically less than 0.1% over most of the range.

**Hum and Noise (0 db or 20 db gain position)**

Less than 0.5 millivolts rms for a detector bandwidth of 100 kHz, rising to 2 millivolts rms for a detector bandwidth of 10 MHz. X100 band, High-Pass mode only, 2 millivolts rms for a detector bandwidth of 100 kHz, rising to 5 millivolts rms for a detector bandwidth of 10 MHz.

**Output DC Level Stability**

$\pm 1$  millivolt per hour,  $\pm 1$  millivolt per degree C.

**Operating Temperature Range**

-10°C to 45°C.

**Front Panel Controls (each channel)**

Frequency Hz: Three rotary decade switches and a six [five] position multiplier switch.

DC Levels: One each screwdriver adjustment control for LP and HP.

Function Switch: LOW-PASS RC, LOW-PASS MAX FLAT, HIGH-PASS.

Gain Switch: 0 db, 20 db.

Power Switch: OFF, LINE OPERATE, BATTERY CHARGE/LINE OPERATE, BATTERY OPERATE.

**Floating (ungrounded) Operation**

A switch is provided on rear of chassis to disconnect signal ground from chassis.

**Terminals**

Front panel and rear of chassis, one BNC connector for Input, one for Output, each channel. One multipurpose connector on rear for chassis ground.

**Power Requirements**

105-125 or 210-250 volts, single phase, 50-400 Hz, 5 watts for Models 3320 and 3321, 10 watts for Models 3322 and 3323.

**Dimensions and Weights**

Model	Cabinet Size/ Weight	Height	Width	Depth	Net	Gross
3320/3321	U. S.	5 1/4"	8 5/8"	13 1/2"	12 lbs	14 lbs
	Metric	13.3 cm	21.9 cm	34.3 cm	5.5 kgs	6.4 kgs
3322/3323	U. S.	5 1/4"	16 5/8"	13 1/2"	24 lbs	31 lbs
	Metric	13.3 cm	42.2 cm	34.3 cm	10.9 kgs	14.1 kgs

**Optional Rack-Mounting Kits**

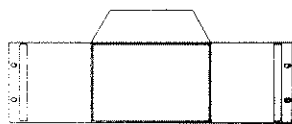

RK-58: Models 3320, 3321



RK-519: Models 3322, 3323

**Optional Battery Kits**

Part No. BK-332, Models 3320, 3321; Part No. BK-334, Models 3322, 3323.

**1.3 FILTER CHARACTERISTICS**

The flexibility of adjustment of bandwidth is shown in Figure 2. Low-pass and High-Pass operation is shown in curves (1) and (2). The solid lines show the maximally Flat Butterworth operation while the dotted lines show the RC characteristic.



Curve (3) shows Band-Pass operation for two different bandwidths, illustrated by curves A and B. Curve B shows the minimum pass-band width obtained by setting the two cutoff frequencies equal. In this condition the insertion loss is 6 db, and the -3 db cutoff frequencies occur at 0.8 and 1.25 times the mid-band frequency. Band-Reject operation for a reject band with a cutoff frequency separation ratio of 10 is shown by curve 4.

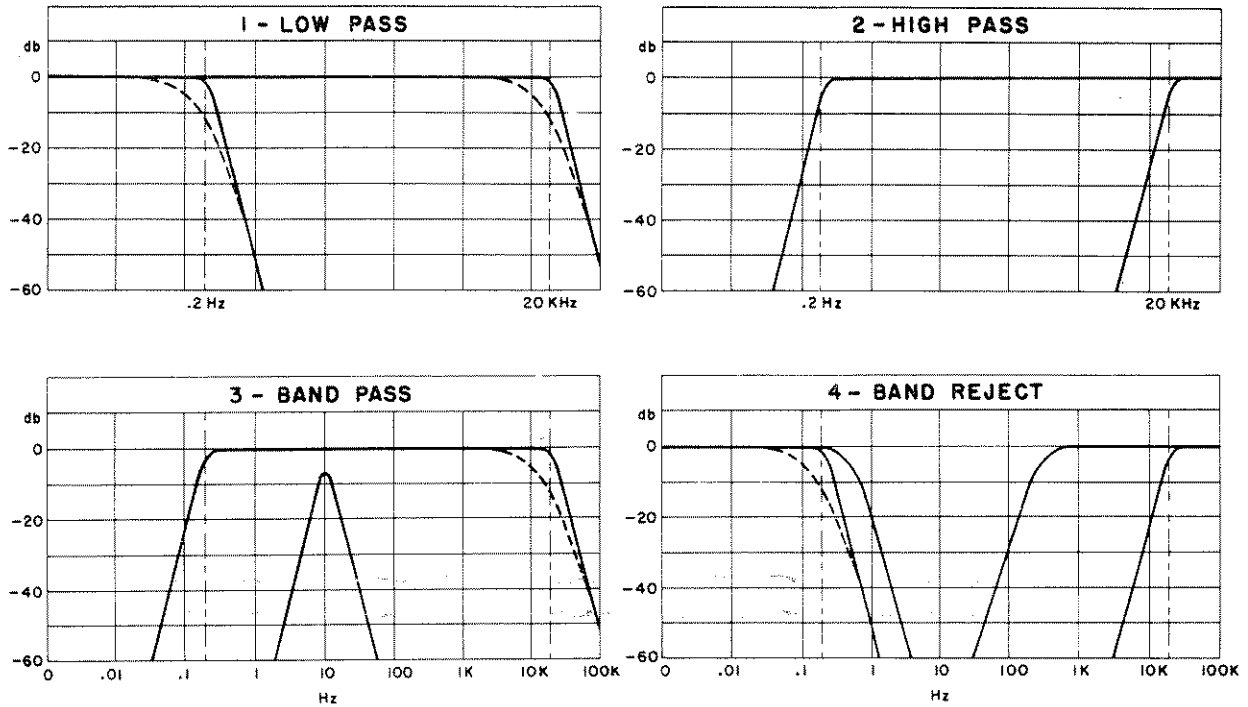
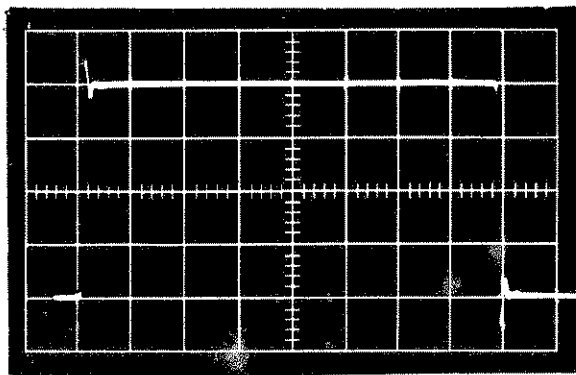
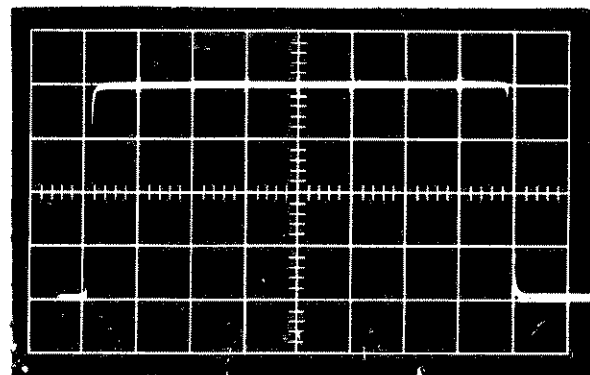

Figure 2. Multifunction Response of Butterworth (solid curves) and Low-Pass RC (dashed curves).



Response (in Low-Pass Mode) to 1 Hz square wave, with cutoff at 1 kHz. Overshoot is approximately 1 db with FUNCTION switch in LOW-PASS MAX FLAT position.



Response to same square wave in LOW-PASS RC (Low Q) position. NOTE complete removal of overshoot.

Figure 3. Filter Response to Square Wave Input.

### 1.3.1 Transient Response

The frequency response of this Filter is a fourth-order Butterworth with maximal flatness, ideal for filtering in the frequency domain. For pulse-type signals, the FUNCTION switch is set to Low-Pass RC (Low Q) to change the response characteristic to the R-C type, optimum for transient-free filtering. Figure 3 shows a comparison of the Filter output response in these modes to a square wave input signal.

### 1.3.2 Cutoff Response

The attenuation characteristics of the Filter are shown in Figure 4. With the FUNCTION switch in the LOW-PASS MAX FLAT (Butterworth) mode, the gain as shown by a solid curve, is virtually flat until the -3 db cutoff frequency. At approximately twice the cutoff frequency the attenuation rate coincides with the 24 db per octave straight line asymptote.

In the LOW-PASS RC mode, optimum for transient-free filtering, the dotted line shows that the gain is down approximately 15 db at cutoff and has approximately a 24 db per octave attenuation rate at five times the cutoff frequency. Beyond this frequency, the Filter attenuation rate and maximum attenuation, in either mode, are identical.

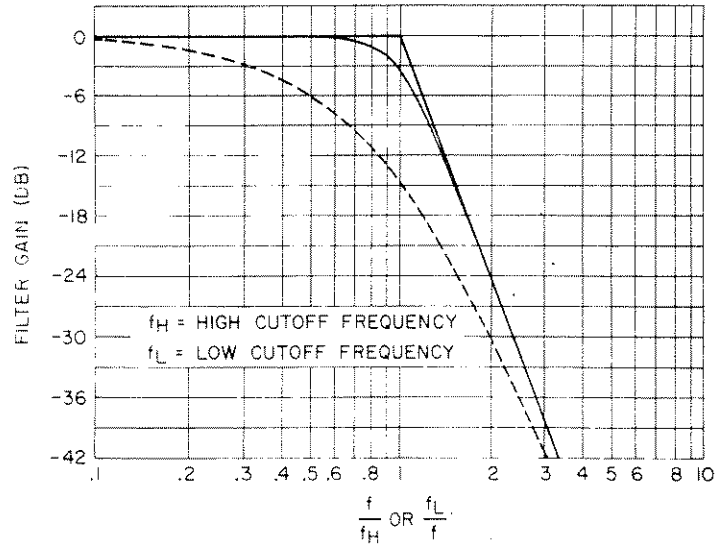

Figure 4. Normalized Attenuation Characteristics

### 1.3.3 Phase Response

The phase response of the Model 3320 (Model 3321) or each channel of the Model 3322 (Model 3323) can be obtained from Figure 5 which gives the phase characteristic for either mode of operation in degrees lead (+) or lag (-) as a function of ratio of the operating frequency ( $f$ ) to the low cutoff frequency  $f_L$  (HIGH-PASS mode) or high cutoff frequency  $f_H$  (LOW-PASS mode).\* The solid curve is for the MAXIMALLY FLAT (Butterworth) mode and the dotted curve is for the transient-free (LOW-PASS RC mode).

#### 1.3.3.1 Example

Determine the phase shift of the filter in the MAXIMALLY FLAT or Butterworth mode, with the FUNCTION switch set to the HIGH-PASS mode at the X1 position, the cutoff frequency ( $f_L$ ) set to 100 Hz and an input frequency ( $f$ ) of 300 Hz.

\* The terms "lead (+)" and "lag (-)" are used only to distinguish between phase shift in the High Pass mode (lead) vs. phase shift in the Low Pass mode (lag). The actual phase shift in either mode, of course, will always be lagging, since the output can never occur before the input.

$$\text{Since } \frac{f}{f_L} = \frac{300}{100} = 3$$

From Figure 5,  $3 = 50^\circ$

The Output of the Filter leads (lags) the Input by 50 (-310) degrees

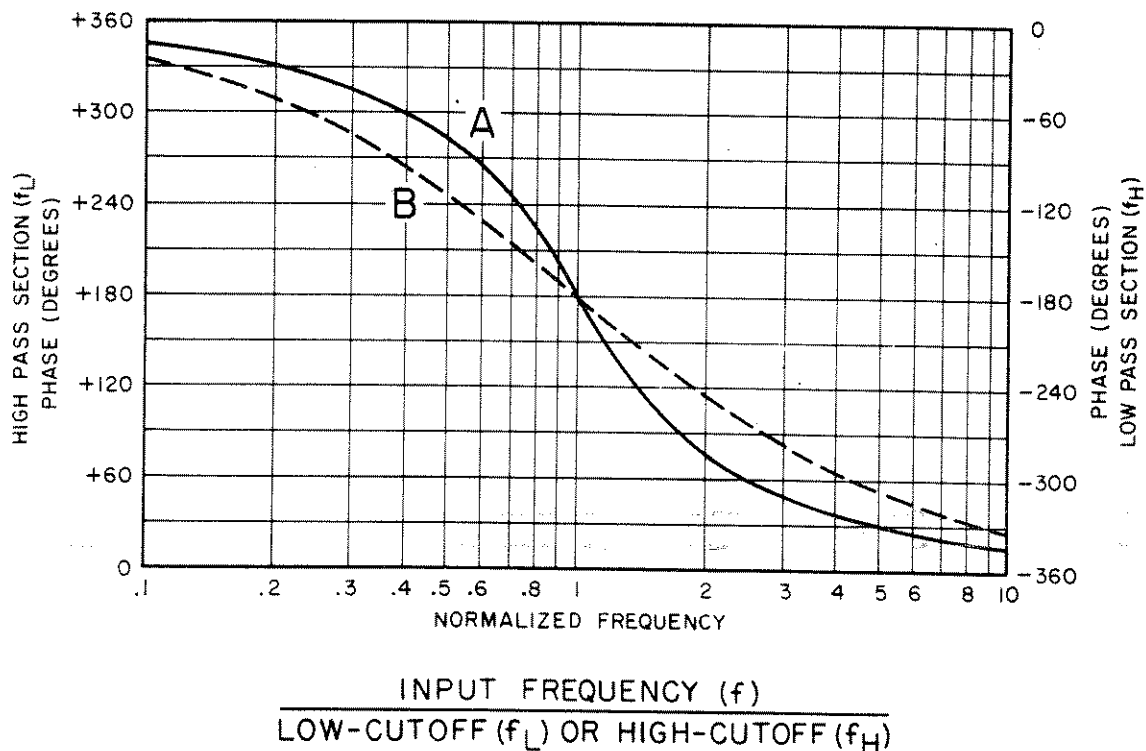

Figure 5. Normalized Phase Characteristics

The phase response of the Model 3322 (Model 3323) could be obtained in the same manner by taking the algebraic sum of the phase response of each channel (Band-Pass operation, only).

The phase error of the Model 3320 (Model 3321) is related to the setting of the cut-off frequency and is approximately  $2.5^\circ$  for a 1% frequency error at the cutoff point. Since the cutoff calibration is  $\pm 2\%$ , a maximum phase error of  $10^\circ$  is possible, although a  $2.5^\circ$  phase error is typical.

For some applications the phase difference between channels of the Model 3322 (Model 3323) can be improved by applying the same signal to both channels simultaneously and tuning one channel to minimize the phase difference. Because the resolution of phase adjustment is limited to that of the frequency digits, the increments of phase adjustment near cutoff will vary from  $0.25^\circ$  to  $2.5^\circ$  when able to use three digit resolution.

## SECTION 2

### OPERATING INSTRUCTIONS

#### 2.1 INTRODUCTION

On receipt of the Filter, carefully unpack and examine it for damage that may have occurred in transit. If signs of damage are observed, file a claim with the transportation agency immediately, and notify Krohn-Hite Corporation. Do not attempt to use the Filter if damage is suspected. Rack-mounting models so equipped mount with four machine screws in the standard 19-inch rack space. No special brackets or attachments are needed.

**CAUTION**

The covers of this instrument should not be removed when the instrument is connected to an AC power source, because of the potentially dangerous voltages that exist within the unit.

#### 2.2 FRONT AND REAR PANEL CONTROLS

The front panel of the Model 3320 (Model 3321) and each channel of the Model 3322 (Model 3323) include three rotary decade switches for frequency digits, a six position (five position - Models 3321 and 3323) rotary multiplier, a three position function switch, a two position gain switch, two BNC coaxial connectors for the INPUT and OUTPUT signals and screwdrive control adjustments for the output dc level in the Low-Pass (LP) and High-Pass (HP) functions. A four position POWER switch selects OFF, LINE, LINE OPERATE/BATTERY CHARGE or BATTERY OPERATE. See Figure 6.

The tuning network consists of 3 digitally tuned decades and a six [five] position multiplier. This combination allows setability of over 5,000 discrete cutoff frequencies, calibration within  $\pm 2\%$  (X, 01 to X10 bands) and resetability of  $\pm 0.01\%$ . Each multiplier position covers the frequency range as follows:

<u>BAND</u>	<u>MULTIPLIER</u>	<u>FREQUENCY (Hz)</u>	<u>RESOLUTION</u>
1	0.001	0.001 - 0.999	0.001
2 [1]	0.01	1 - 9.99	0.01
3 [2]	0.1	10 - 99.9	0.1
4 [3]	1	100 - 999	1
5 [4]	10	1,000 - 9,990	10
6 [5]	100	10,000 - 99,900	100

The rear chassis of the Model 3320 (Model 3321) and each channel of the Model 3322 (Model 3323) has a switch for disconnecting the signal ground from chassis ground.

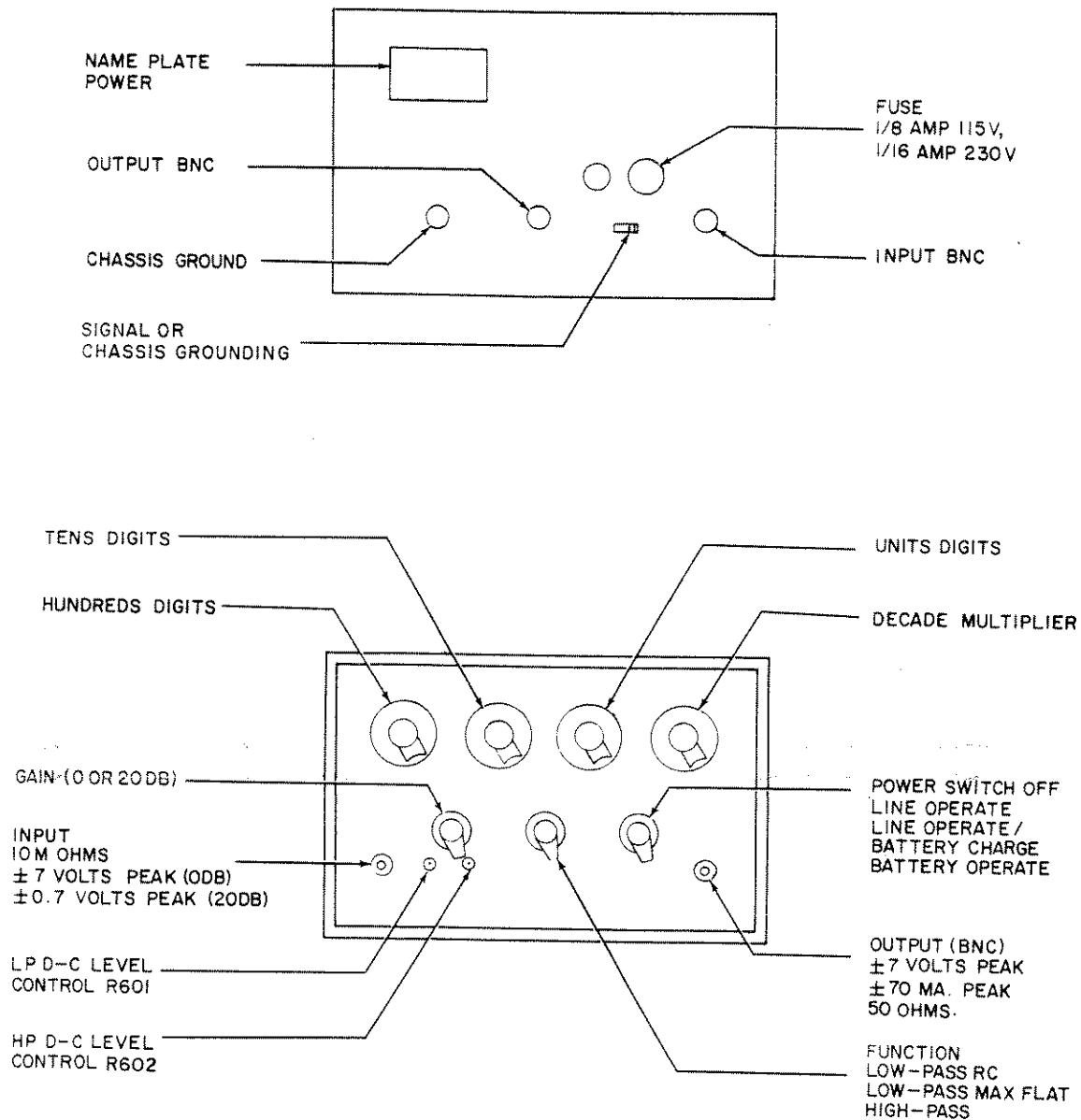

Figure 6. Controls and Connections for Models 3320, 3321, and Each Channel of Models 3322, 3323

### 2.3 OPERATION

#### 2.3.1 Model 3320 and Model 3321

- a. Make appropriate power connections as described in Section 2.6.
- b. Make appropriate connections to the INPUT and OUTPUT connectors of the Filter. The INPUT voltage should not exceed plus or minus 7 volts peak in the 0 db gain position, or plus or minus 0.7 volts peak in the 20 db gain position, and the combined AC and DC INPUT voltage should not exceed 7 volts peak in the Low-Pass mode.
- c. Set mode of operation and cutoff frequency by means of the band multiplier switch, the frequency decades and the FUNCTION switch.

d. Turn power switch to LINE, LINE/BATTERY CHARGE or BATTERY OPERATE - whichever is applicable.

e. After sufficient warm-up time check output dc level in the Low-Pass and High-Pass mode, and if necessary, adjust DC LEVEL potentiometers, R601 and R602, for zero volts on the output.

NOTE

High-Pass dc level must always be adjusted first.

f. For normal Filter operation the FLOATING/CHASSIS GROUND switch, located on the rear of the chassis, should be in the CHASSIS position. If the Filter is used in a system where ground loops make ungrounded operation essential, this switch should be in the FLOATING position.

CAUTION

In FLOATING operation, the signal ground should be connected to system ground to prevent excessive hum and noise.

g. When filtering consists principally of separating frequency components of a signal (frequency domain), the RESPONSE switch should be in the MAX-FLAT position. If the Filter is used to separate pulse-type signals from noise (time domain), this switch should be in the RC position.

2.3.2 Model 3322 and Model 3323

2.3.2.1 To Obtain High-Pass or Low-Pass Operation with 48 db Per Octave Attenuation, Proceed as Follows:

- a. Cascade the two channels by connecting the output of the left channel to the input of the right channel.
- b. Select identical mode of operation and multiplier position for both channels.
- c. Set frequency digits of both channels to the same cutoff frequency.

NOTE

When the two channels are cascaded and set to the same mode of operation with identical cutoff frequencies, the gain at the cutoff frequency will be down 6 db from the pass-band gain with the two RESPONSE switches in the MAX-FLAT (Butterworth) position. In the Low-Pass RC position the gain at cutoff frequency will be down approximately 30 db.

d. In the Model 3322 (Model 3323) if the gain switch of each channel is set to 20 db the resultant overall gain is 40 db. Under these conditions the output of the first channel cannot exceed  $\pm 0.7$  volts peak or it will overload the input to the second channel. This limits the input signal of the first channel to  $\pm 0.07$  volts peak. When one channel is operated with 20 db gain, the signal to noise ratio improves by 20 db. However, the signal to noise ratio, when both channels are in cascade, does not improve by 40 db because the noise of the first channel is amplified by the second channel.

**2.3.2.2** To Obtain Band-Pass Operation with 24 db per Octave Attenuation, Proceed as Follows:

- a. Cascade the two channels.
- b. Set the left channel to the High-Pass Mode (this will control the Low-Cutoff frequency). Set the right channel to the Low-Pass mode (this will control the High-Cutoff frequency).

Band-Pass operation could also be obtained by setting the left channel to the Low-Pass mode and the right channel to the High-Pass mode. The first method has the advantage that the Low-Cutoff Frequency (High-Pass mode) is on the left and the High-Cutoff Frequency (Low-Pass mode) is on the right, which is the logical arrangement since it coincides with our customary graphical representation of a Band-Pass Filter. This may be disadvantageous, since the output is dc-coupled, because the Low-Pass channel is on the right. If the second method is used, the output amplifier is ac-coupled, which is desirable in some applications where only minimum dc fluctuations on the output can be tolerated.

- c. The minimum Pass-Band is obtained by setting the High-Cutoff Frequency equal to the Low-Cutoff Frequency. In this condition the insertion loss is nominally 6 db and the -3 db cutoff frequencies occur at 0.8 and 1.25 times the mid-band frequency. See curve 3B in Figure 2.

**2.3.2.3** To Obtain Band-Reject or Notch Filter Operation, Proceed as Follows:

- a. Connect the two channels in parallel by connecting the input signal to the BNC INPUT connector of both channels simultaneously. The OUTPUT from both channels should be added through two equal external resistors in series with each output.\* The junction of these resistors becomes the output of the Filter. It is recommended that the resistors be approximately 50 ohms and of the carbon or metal film type if the Filter is used at high frequencies. If the two resistors are not equal, the gain on one side of the notch will be different than the gain of the other.

- b. The first channel should be set for Low-Pass operation.
- c. The second channel should be set for High-Pass operation.
- d. It should be noted that the output impedance in the Band-Reject mode will not be 50 ohms, but approximately 25 ohms plus one half the resistance of one adding resistor. The maximum input should not exceed 5 (0.5 in 20 db gain position) volts rms and the maximum output voltage in this mode will be 2.5 volts rms open circuit.

- e. Because the resolution is limited to one part in 3 decades, the sharpness of null will vary, depending on frequency. Although a typical null is 60db, a null greater than 80 db is possible due to phase cancellation.

## 2.4 HUM AND NOISE

The hum and noise of the Filter is composed of white noise and line frequency harmonics. The actual noise observed at the output will depend on the Filter setting. Narrower pass-band will produce less noise, as will a setting that rejects line frequency and harmonics.

\*An optional Band Reject Kit (Part No. BK-30) is available, and consists of matched cables and connectors to adapt the filter channels for parallel operation.

## 2.5 TERMINALS

BNC coaxial connectors are provided on the front panel and on the rear of the chassis for both INPUT and OUTPUT connections.

## 2.6 POWER REQUIREMENTS

### 2.6.1 Line Operation

The Filter, unless otherwise specified, is wired for operation from an ac power source of 105-125 volts, 50 to 400 Hz.

The Model 3320 (Model 3321) and each channel of the Model 3322 (Model 3323) uses a 1/8 ampere slow blow line fuse mounted on the rear of the chassis. This may be modified to operate from a 210-250 volt line by removing the two jumpers connecting terminals 1 to 3, and 2 to 4 of the power transformer(s), and adding a jumper between terminals 2 and 3 of the power transformer(s). In the Model 3322 (Model 3323) there are two power transformers and both should be modified when the line voltage is changed. For 210-250 volt operation a 1/16 ampere slow blow fuse should be used for the Model 3320 (Model 3321) and each channel of the Model 3322 (Model 3323).

### 2.6.2 Optional Battery Kit

If specified, the Filter will be supplied with batteries installed. To operate the Filter using battery power, it is only necessary to set the power switch to BATTERY OPERATE. Batteries may be added to any instrument at any time. For Models 3320, 3321 order Part No. BK-332; for Models 3322, 3323 order Part No. BK-334.

## 2.7 INSTALLATION OF BATTERIES

To install batteries remove the side, top and bottom covers. At the rear of the chassis, two clamps and two brackets are provided to hold the two batteries. See Figure 7. The batteries should be 12 volt Union-Carbide type Y5403.

Place one battery (BT102-Figure 7), with the negative pole facing the bottom of the chassis, and the other (BT101) with the positive facing the bottom. Connect a wire from the plus terminal of TB301 to the positive pole of Battery BT101 and a wire from the negative terminal of TB301 to the negative pole of battery BT102. Turn chassis over and connect the two remaining poles of the batteries together. Connect a lead from this point thru the small grommet (see Figure 7) to the ground terminal on TB301.

The batteries used in the 3320 Series are of the nickel cadmium type. These batteries may be recharged many times without loss of performance, and are designed to operate continuously for 10 hours without recharging.

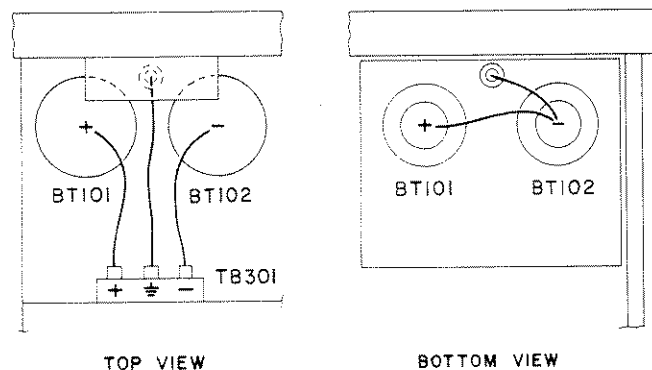

Figure 7. Installation of Batteries



Due to the type of battery used in the 3320 Series, it is difficult to determine the state of charge on the batteries. If the open circuit voltage of the battery is greater than 13 volts, it is more than likely that the battery is sufficiently charged for 10 hours operation. If voltage is less than 13 volts, it is recommended that the battery be charged for approximately 14 hours. If the battery will not operate for 10 hours after charging for approximately 14 hours, it should be replaced. The internal charging circuit of the filter is designed to recharge the batteries to full capacity in 12 to 16 hours. For optimum battery performance prolonged periods of continuous charging (greater than 16 hours) should be avoided.

## SECTION 3

### CIRCUIT DESCRIPTION

#### 3.1 INTRODUCTION

As shown in the Simplified Schematic Diagrams, Figures 8 and 9, the Model 3320 (Model 3321) and each channel of the Model 3322 (Model 3323) is a four-pole, variable, electronic filter that can be operated as either a Low-Pass or a High-Pass Filter. It has a variable cutoff frequency adjustable between 0.001 Hz and 99.9 kHz (0.01 Hz and 99.9 kHz - Models 3321 and 3323) by means of three frequency decade switches and a six-position (five position - Models 3321 and 3323) multiplier switch. In the Low-Pass mode, it is direct-coupled and, in the High-Pass mode, its upper 3 db point is approximately 1 MHz. A response switch selects either Butterworth (maximally flat response) or a RC frequency characteristic, which improves the transient response by eliminating overshoot when pulsed input signals are applied.

The Schematic Diagram of the Model 3320, (Model 3321), Figure 11, is at the rear of this manual. Bold lines on the Schematic Diagram show the main signal paths, while the dashed lines indicate feedback signal paths. As shown in Figures 8 and 9, the Model 3320 (Model 3321) consists of four RC tuning elements coupled by Network Amplifiers. The cutoff frequency is tuned capacitively in decade steps by the band switch, and digitally within each decade by the frequency decade switches. The same capacitors and resistors are used in both the High-Pass and the Low-Pass mode.

The Model 3320 (Model 3321) Filter consists of a pair of two-pole R-C sections - "Quadratics" - coupled together by two Network amplifiers. Each Quadratic is adjusted to give a Butterworth response when both are cascaded. The response of the first Quadratic falls off smoothly with no peak as the frequency approaches the cutoff frequency, and the gain at cutoff is -5.3 db. The response of the second Quadratic is peaked approximately 2.3 db at the cutoff frequency and when both Quadratics are cascaded, the resultant response is flat with no peak and a sharp falloff as it goes through cutoff.

#### 3.2 DETAILED DESCRIPTION

##### 3.2.1 Input Amplifier

The Input Amplifier is a two stage operational amplifier consisting of dual FET Q130, and transistors Q133, and Q134. Q130 forms a balanced stage with the input signal applied to the gate of Q130A and the gate of Q130B at zero signal level. Resistors R132, R136, R137 and R138, broadbanded by capacitors C131, C132, C135 and C136 form the gain determining feedback network in the "20 db" position of the "GAIN" switch. In the "0 db" position R136 and C132 are shorted and the gain is determined by R131, R138, C131, C135, C136. R137 is ineffective because it is just loading the summing point of an operational amplifier.

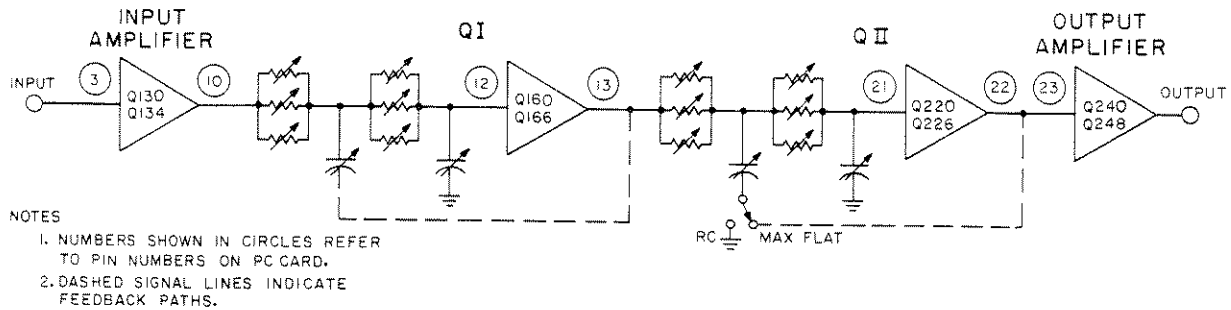

Figure 8. Simplified Schematic Diagram in Low-Pass

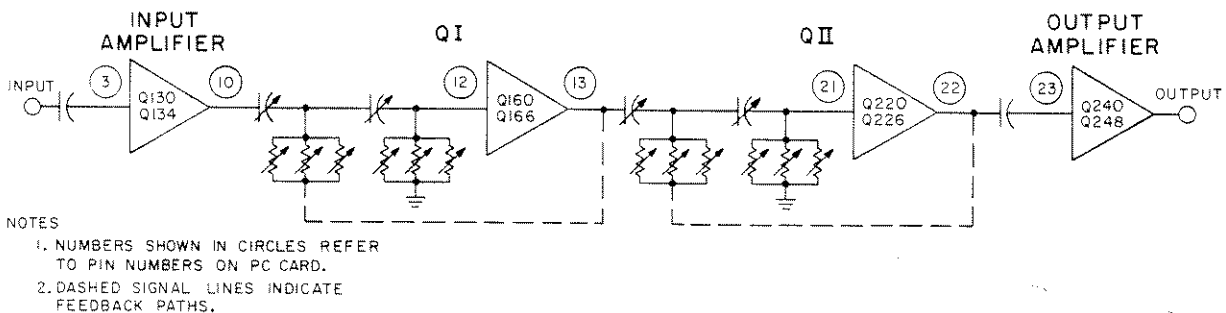

Figure 9. Simplified Schematic Diagram in High-Pass

The input signal in the LOW-PASS mode is direct coupled and is applied thru R132 to the gate of Q130A. R132, in addition to determining the gain of the amplifier, acts as current limiting to prevent damage to the Filter in the event of excessive input signal. In the HIGH-PASS mode the input is capacitor coupled by C271 and C273 (and C272 in Models 3320 and 3322 only) which allows input signals with a D-C component of plus or minus 100 volts to be applied to the input without overload.

The output stage, Q133 and Q134, develops the low impedance output to drive the first R-C network. Diodes CR131 and CR132 cancel thermal drift in Q133 and Q134.

### 3.2.2 Network Amplifier

The operation of all Network Amplifiers is nearly identical, and only the first Network Amplifier - Q160 to Q166 - will be presented in detail. The first Amplifier consists of a balanced input stage - Q160 and a balanced output stage - Q164, Q165 which develops the drive signal for the following section of the R-C tuning network. The input signal from the preceding network is applied to the gate of Q160B with local feedback going to the gate of Q160A. For maximum signal swing, transistors Q163 and Q166 maintain constant current in the input and output stages. At low frequencies, trim resistor R161 (R221 in second Quadratic) is adjusted for

optimum cutoff calibration. This trim is modified on the two highest bands, X10 and X100, by trim resistors R272 (R284) and R273 (R285) in the Low-Pass mode and R274 (R286) and R275 (R287) in the High-Pass mode. Trim capacitors C164 and C166 (C223, C224 in second Quadratic) are adjusted to neutralize the effect of capacitance loading on the input of the amplifier - gate of Q160B (Q220B second Quadratic).

### 3.2.3 R-C Tuning Network

Models 3320, 3321 (and each channel of Models 3322, 3323) is a 4-pole filter, consisting of 2 2-pole sections or "Quadratics" (so called because the transfer function of each is a 2nd order or quadratic function). Each quadratic has 2 cascaded RC tuning elements and an amplifier that acts as buffer between stages and also provides the gain necessary in an active filter.

The desired frequency characteristic of each Quadratic is effected by feeding back the suitably amplified output signal to the first R-C network. The gain of each amplifier is adjusted for the proper response of each quadratic, so that cascaded they produce a Butterworth characteristic. The resistive component of the tuning network consists of three rotary switches, calibrated from 0 to 9 in hundreds, tens, and unit steps.

These switches select the proper resistor in each of the R-C networks. The capacitive element of the tuning network is selected by the rotary multiplier, calibrated in decades from X.001 to X100 (X.01 to X100 - Models 3321, 3323).

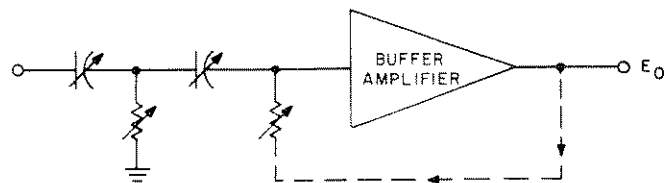

Figure 10. Typical Quadratic Amplifier Shown in High-Pass

### 3.2.4 Output Amplifier

The output Amplifier is a four stage operational amplifier consisting of dual FET Q240 and transistors Q243 thru Q248. FET Q240 form a balanced stage with the input signal applied to the gate of Q240A and the second input of the amplifier (gate of Q240B) at zero signal level. The output of this stage is connected to the differentially connected transistors Q243 and Q244 which drive the next stage, Q245 and Q246.

Transistors Q247 and Q248 form a complementary emitter follower and produce the high current, low impedance output of the filter. Q246, Q247 and Q248 of the output amplifier are connected to the plus and minus 15.5 volt unregulated supply which enables an output signal swing of plus or minus 7 volts peak and a maximum current of plus or minus 70 ma. At low frequencies, the gain of the amplifier is determined by resistors R265, R256, R241, R244 and trim R257, broadbanded by capacitors C241, C242, and C247. In the High-Pass mode this divider is modified on the two highest bands, X10 and X100, by R288 and R290 and capacitors C324, X10 band, and C325 on the X100 band. In the Low-Pass mode the gain of the amplifier is modified on the X10 and X100 bands by R291 and R292 respectively.

### 3.2.5 Butterworth RC Response

This Filter has a maximally flat or Butterworth characteristic when the FUNCTION switch is in the Low-Pass MAX FLAT position. To provide minimum overshoot to fast rise pulses the feedback of the second Quadratic is disconnected by S603 when the FUNCTION switch is in the Low-Pass RC position.

### 3.2.6 Power Supplies

The Power Supplies of the 3320 Series consist of two unregulated supplies, plus and minus 15.5 volts and two regulated supplies of plus and minus 9 volts.

In the Battery mode of operation, the unregulated supplies come from the internal batteries, BT101 and BT102. In the Line mode of operation, the unregulated supplies are derived from the rectifiers CR103 thru CR106.

The -9 volt regulated supply is a typical series type using a zener reference, Z101, and the amplifiers Q103 and Q104 which drive a series regulator Q106. To prevent damage when short circuits of the regulated voltage occur, a current limit circuit consisting of CR111 and CR112, turns off the -9 volt supply if the current in R121 exceeds a predetermined value. The +9 volt supply uses the -9 volts as a reference. A divider network, consisting of R106, R108 and TRIM resistor R107, sets the proper voltage level for the amplifiers Q101 and Q102, which drive the series regulator Q105. CR108 and CR109 limit the current in the +9 volt supply.

## SECTION 4

### MAINTENANCE

#### 4.1 INTRODUCTION

If the Filter is not functioning properly and requires service, the following procedure may facilitate locating the source of trouble. Access to the Filter is accomplished easily by removing the top and bottom covers. It is first necessary to remove the four black thumb screws centered at the rear of each cover. Removing the two side covers will then unlock the top and bottom covers.

The general layout of major components, test points, screwdriver controls and detailed component layout for the printed circuit card is shown in Figure 11. Various check points are shown on the Schematic Diagram and are also marked on the printed circuit card. To allow for ease of service, the printed circuit card is provided with a swing-out mounting. Loosening of two screws, one on each end, will allow the card to drop and provide access to the components. A locking device permits the card to remain in a 90° position to facilitate servicing.

Many troubles may easily be found by visual inspection. When a malfunction is detected, make a quick check of the unit for such things as broken wires, burnt or loose components, or similar conditions which could be a cause of trouble. Any trouble-shooting of the Filter will be greatly simplified if there is an understanding of the operation of the circuit. Before any detailed trouble-shooting is attempted, reference should be made to Circuit Description, Section 3, to obtain this understanding.

#### WARNING

This maintenance procedure should be performed by qualified personnel, only. If the covers must be removed during the troubleshooting procedure, it is strongly recommended that extra precautions be taken in working with exposed circuitry, and that insulated probes and/or tools be used.

SHUT THE POWER SWITCH OFF AND DISCONNECT THE LINE CORD FROM THE POWER SOURCE BEFORE REPAIRING OR REPLACING COMPONENTS.

#### 4.2 POWER SUPPLY

If the Filter does not seem to be working properly, the two power supplies should be checked first. The supplies should measure 9.0 volts  $\pm 0.5V$  and be of equal magnitude (within 50 mv). If the two supplies appear to be correct, refer to the signal tracing analysis, Section 4.3.

A fuse, F701 (1/8A for 115V or 1/16A for 230V operation), located at the rear of the chassis, is provided to protect the power supply from short circuits and overloads. The rating of this fuse was selected for proper protection of the Filter, and it should be replaced with one of the same type and rating. Two regulated supplies are used to provide +9 volts and -9 volts with respect to the ground. The -9 volt supply uses a zener (Z101) as its reference, while the +9 volt supply uses the minus supply as its reference. This fact should be kept in mind when doing any work on the supply, as an error in the minus will be reflected in the plus. Both supplies are provided with current limiting circuits that will shut down the supply when excessive current is being drawn from it. Because of this, an apparent power supply malfunction may be caused by an overload in the Filter. This may be determined by measuring the voltage across R116 and R121. It should not exceed 0.6 volts. If the plus supply is slightly out of tolerance, R106, R108 or Trim resistor R107 may be defective.

If the supply does not appear to be working properly, the error signal thus developed should be traced through the regulator loop to find the faulty component. Correct voltages for various points in the supply are shown on the Schematic Diagram, Figure 11. As an example of this method of troubleshooting, let us assume that the -9 volt supply is very low. This should make the base of Q103 more positive than normal, making its collector, and the base of Q104 more negative. The base of Q106 should then be made more positive than normal and the collector more negative, thus correcting the output of the supply. If a faulty component is present in the regulating loop, this corrective action would be blocked. That component would then be found at the point in the loop where the action was blocked. The plus supply uses approximately the same type of circuit and the same basic method of troubleshooting may be used there as well.

#### 4.3 SIGNAL TRACING ANALYSIS

If the power supplies appear to be functioning properly, but the Filter is not working in one or more modes of operation, the following procedure should localize the malfunction.

#### CAUTION

Due to the high impedances and light currents present in the circuit, it is necessary to use a high impedance, low capacitance meter when making any a-c or d-c measurements.

#### 4.4 LOW-PASS AND HIGH-PASS MALFUNCTION

If the Filter does not function properly in both the Low-Pass and High-Pass modes, it is recommended that the following signal tracing analysis be followed: Set the Multiplier switch to the X1 position in the High-Pass mode and the frequency decades to 600. Set the Gain switch to 0db. Connect a 600 Hz, 1 volt rms sine wave signal to the input of the Filter. If a 0.7 volt signal does not appear at the output, the malfunction may be localized by determining where the signal first deviated from normal in the Filter.

Table 1 shows various test points with their correct signal levels. If a test point is found whose signal differs appreciably from the correct value, the circuitry associated with that test point should be carefully checked. The test points basically trace the signal through the entire Filter, and should be checked in the order given. DC level voltages are shown on the Schematic to aid in determining the defective component.

TABLE 1. Test Points for Low-Pass and High-Pass Operation

Test Point	Correct RMS Volts	Probable Section with Failure
3	1.0	S603A, S604A, C271, C272, C273 defective.
10	0.25	Input Amplifier: Q130 thru Q134.
12	0.13	S603B, S604B, S605B, C, D; and associated components, Network Amplifier Q160 to Q166.
13	0.15	Network Amplifier: Q160 to Q166.
21	0.18	S603D, S605F, G, H, I; S604H, G; and associated components. Network Amplifier Q220 to Q226.
22	0.43	Network Amplifier: Q220 to Q226.
23	0.43	S603E, C323, C326, C327.
27	0.70	Output Amplifier: Q240 to Q248.

#### 4.5 INPUT AMPLIFIER

If the error appears to be in the Input Amplifier (Q130 to Q134), the easiest method of trouble-shooting is to monitor the various d-c levels in the amplifier. Short the input to the Filter and set the Filter to 100 Hz in the High-Pass mode. Nominal voltages for various points are given in the Schematic Diagram, Figure 11. If a malfunction occurs, the error signal thus developed should be traced through the circuit to find the faulty component. Let us suppose, for example, that the output d-c level of the Input Amplifier, (terminal 10 on PC101) is more positive than its normal voltage of  $0 \pm 0.1$  volts and cannot be corrected by adjusting R601 Low-Pass DC Level Adjust. This would produce an error signal which would make the gate of Q130A more positive than normal, increasing the current in Q130A and lowering the current in Q130B. The voltage on the base of Q133 would be less positive than normal, and the base of Q134 would be more positive than normal. This would decrease the current in the output transistors, Q133 and Q134, and restore the output d-c level of the amplifier to its normal level. Had there been a bad component present in the circuit, it would have prevented this corrective action from taking place. The faulty component will be found at the point in the circuit where the correcting action is blocked.

#### 4.6 OUTPUT AMPLIFIER

If the error appears to be in the Output Amplifier, check the d-c level of the Filter output. Using the same troubleshooting procedure as in the Input Amplifier, the malfunction can be localized by tracing the d-c error signal through the amplifier. Let us suppose, for example, that the output level is more positive than its normal voltage of  $0 \pm 0.1$  volts and cannot be corrected by adjusting R602 High-Pass DC Level Adjust. The positive error signal at the output would make the gate of Q240A more positive, increasing the current in Q240A and decreasing the current in Q240B. The resulting unbalance would decrease the current in transistors Q243 and Q244, raising the d-c voltage on base of Q245. This would decrease the current in the output stage and restore the output level to its normal value.



#### 4.7 TUNING CIRCUITS

If the signal tracing analysis shows one of the tuning circuits to be faulty, it should be determined if the trouble is in the resistive or in the capacitive element. If there is trouble in a capacitive element, this will show up only on one multiplier band. If there is a problem in a resistive element, the trouble will show up only on that one position of the decade switch and on all multiplier bands.

The range-determining capacitors, associated with the multiplier switch, S604, are specially selected for close capacitance tolerance. All capacitor values fall within  $\pm 5\%$  of the specified value, but in order to maintain accurate frequency calibration over the entire range and also between decade ranges, the capacitors are matched within  $\pm 0.1\%$  of each other and generally within  $\pm 0.2\%$  in decade ratios. The value of capacitance used on the higher bands are selected to compensate for stray capacitance and are therefore not completely in decade ratios of those used on the lower bands. For replacement purposes, it is recommended that several other capacitors on the switch be carefully measured on a capacitance bridge to determine the average percentage deviation from the nominal value. Any capacitors except those used on the two highest frequency ranges may be measured to determine this tolerance. Replacement can be made with capacitors of exact value, and calibration will not be impaired.

The variable resistive element consists of three decade switches which, in each position, connect a separate resistor to each R-C section. Thus, a total of 36 resistors are mounted on each decade switch. For replacement purposes, the resistors on the hundreds decade should be selected to within  $\pm 0.1\%$  of nominal value. On the tens decade the tolerance should be  $\pm 0.5\%$ , and on the units decade,  $\pm 1\%$ .

#### 4.8 NETWORK AMPLIFIER

There are two Network Amplifiers in each 4 pole filter channel. The first Network Amplifier consists of transistors Q160 thru Q166 (terminals 11, 12 and 13 on PC101), associated components and wiring, and the second Network Amplifier consists of Q220 thru Q226 (terminals 14, 15 and 16), associated components and wiring. If the trouble appears to be in one of the Network Amplifiers, remove the input signal, set the Filter to High-Pass and check the d-c levels in the Quadratic Amplifier. This can be done most easily by tracing the error signal from the output of the amplifier thru the feedback network and thru the amplifier. Correct d-c levels are shown on the Schematic Diagram, Figure 11. For instance, if the error is in the first Network Amplifier (Q160 thru Q166), check the d-c level on the input of the amplifier (gate of Q160B) which is the output of the R-C tuning network. If it is greater than  $0 \pm 0.1$  volts, check the resistor in the tuning network which connects to this point it might be open. If the output level of the amplifier (terminal 13) is appreciably more positive than 0.1 volts, the feedback will make the gate of Q160A more positive. This will unbalance the input stage and increase the current in R166 and decrease the current in R167. This will bias Q164 and Q165 off, and because Q166 maintains constant current in Q164 and Q165, the net effect is to make the output level more negative, counteracting the error.

#### 4.9 CALIBRATION ERROR

If an error in calibration is present, it is necessary to determine which Quadratic(s) or R-C tuning section(s) is contributing the error. In all measurements it is necessary to use an A-C meter with a high impedance, low capacitance input. While measuring the various test points, monitor the output signal on an oscilloscope to be sure that the unit does not oscillate when the meter is applied to the circuit. To

check the first Quadratic, apply a sine wave signal to the Filter input. Set the frequency of the oscillator to a factor of ten higher than the cutoff setting if operating in the High-Pass mode and a factor of ten lower than the cutoff setting if operating in the Low-Pass, Max Flat, mode. To check the first Quadratic, set the voltage at terminal 13 to 0.1 volts rms (0 db). Set the frequency of the oscillator to that of the cutoff setting. Be sure that the amplitude of the input signal remains constant. The voltage at terminal 13 should be down  $5.3 \pm 0.1$  db in respect to the pass-band gain. If OK, proceed to the second Quadratic. If off, check the gain of the associated Network Amplifier. In the first Network the amplifier gain (terminals 11 to 13) should be  $0.2 \pm 0.1$  db. If off, refer to Section 4.8, Network Amplifier. If the Network Amplifier gain is correct, but the overall gain is off, the error is more than likely in the R-C tuning network - refer to Section 4.7, R-C Tuning Network. To check the second Quadratic, again set the oscillator frequency a factor of ten away from the cutoff setting, which is the reference frequency. Set the voltage at the output, terminal 22, to 0.1 volts rms (0 db). Measure the voltage at the input, terminal 13, and set the frequency to the cutoff setting and reset the input amplitude at terminal 13 to the level of the reference frequency. Measure the voltage at terminal 22 which should be peaked  $2.3 \pm 0.1$  db in respect to the pass-band gain (0 db). If off, check the gain of the associated Network Amplifier (terminals 15 and 16), which should be 2.5 to  $\pm 0.1$  db - refer to Section 4.8, Network Amplifier. If OK, error is more than likely in the R-C tuning network, see Section 4.7.

## SECTION 5

# CALIBRATION AND ADJUSTMENT

### 5.1 INTRODUCTION

The following procedure is intended as an incoming acceptance procedure and a periodic maintenance check. The steps outlined follow very closely the operation performed on the instrument by our Final Test Department, and strict adherence to this procedure should restore the instrument to its original specifications. If any difficulties are encountered, please refer to Section 4, Maintenance. It is recommended that the test equipment used to perform the tests be of the quality of that listed in Section 5.3, Test Equipment Required. If any questions arise which are not covered by this procedure, please consult our Factory Service Department.

### 5.2 DETAILED SPECIFICATIONS

#### 5.2.1 Cutoff Frequency Calibration

The high and low cutoff frequencies, as defined below, should be within  $\pm 2\%$  of the corresponding frequency setting with the exception of the highest band and frequencies below 0.05 Hz, where the calibration accuracy is  $\pm 10\%$ . The cutoff frequency in the maximally flat or Butterworth mode is defined as the frequency at which the gain of the Filter is 3 db down from the gain of the pass-band. In the RC or transient-free mode, this cutoff frequency gain is approximately 15 db down.

#### 5.2.2 Pass-Band Gain

The Filter output voltage under open circuit conditions will be within  $0 \pm 1/2$  db or  $20 \pm 1/2$  db of the input voltage for all frequencies within the pass-band on bands X.001 [0.01] thru X10. The X100 band will be  $0 \pm 1$  db or  $20 \pm 1$  db. The pass-band gain is approximately -3 db at 1 MHz.

#### 5.2.3 Attenuation Slope

A typical attenuation curve is shown in Figure 4. At the cutoff frequency, in the maximally flat or Butterworth mode, the slope is approximately 12 db per octave, and at the 12 db point the slope has essentially reached its nominal value of 24 db per octave. The slope of the straight portion may vary slightly from 24 db per octave at certain frequencies because of cross coupling effects.

#### 5.2.4 Maximum Attenuation

This Filter has a maximum attenuation specification of 80 db which applies over most of the frequency range. At the high frequency end this attenuation is reduced due to unavoidable cross coupling between the input and the output. When measuring maximum attenuation, it is essential to use an oscillator with low distortion. Due to the sharp slope of the Filter, the third harmonic component of the input signal

in the High-Pass mode may appear amplified 100 times with reference to the fundamental. In the Final Test of the Model 3320 a Krohn-Hite Model 3202 Filter is used to filter all but the fundamental signal.

#### 5.2.5 Output Impedance

The Filter will operate into any load impedance, providing the maximum output voltage and current specifications are not exceeded. For a matched load impedance of 50 ohms the insertion loss will be approximately 6 db. Lower values of load resistance will not damage the instrument, but may increase the distortion. Higher values of external load may be used with no sacrifice in performance and correspondingly lower insertion loss. In KROHN-HITE Filters there is no requirement to match output impedance.

#### 5.2.6 Internally Generated Hum and Noise

The internally generated hum and noise measurement is based on the use of a Ballantine Model 314A Voltmeter, or equivalent. The measurement is made with input connector shorted, the Chassis/Floating ground switch in the Chassis position, and with no other external signal connection to the instrument, the voltmeter shielded and the bandwidth of the meter limited to 100 kHz and 10 MHz.

### 5.3 TEST EQUIPMENT REQUIRED

- a. Oscillator: Frequency range 0.01 Hz to 1 MHz, distortion less than 0.02%. Output voltage greater than 5 volts rms. Krohn-Hite Model 4100A or equivalent.
- b. AC Volt Meter: 10 Hz to 10 MHz Ballantine Model 314A or equivalent.
- c. Band-Pass Filter: To measure maximum attenuation. Pass-band frequency 20 Hz to 2 MHz. Krohn-Hite Model 3202 or equivalent.
- d. High impedance DC Voltmeter: 15 volts dc full scale, Fluke Model 8000A or equivalent.

### 5.4 GENERAL PROCEDURE

- a. All dc voltage measurements should be made with a High Impedance Voltmeter, and made with respect to ground (chassis), unless otherwise specified.
- b. Give the instrument a thorough visual inspection, looking particularly for discoloration of components, loose or broken wires, damaged switches, poor solder connections, etc.
- c. For location of adjustments and test points referred to in this procedure, refer to Figure 11.

## 5.5 POWER SUPPLIES

With the Filter operating at 115 volts line, 230 volts line or internal batteries, whichever is applicable, check the plus and minus 9 volt supplies with respect to ground. The Floating/Chassis grounding switch, located at the rear of the chassis, should be in the Chassis position. The plus 9 volt supply may be checked most easily at the plus side of C103 (100 ufd, 25 volt, electrolytic) and the minus 9 volt supply may be checked most easily at the negative side of C104 (100 ufd, 25 volt, electrolytic).

## 5.6 DETAILED TEST PROCEDURE

Table 2 contains a detailed test procedure to check the performance of the Models 3320 and 3321. The procedure is to be performed in the given order (1 thru 33). For the Models 3322 and 3323 this procedure should be repeated for the second Filter section. For all steps, the unit should be powered from 115 volts or 230 volts line, whichever is applicable, or from fully charged batteries. Throughout the procedure Low-Pass is abbreviated LP and refers to the operation in the Low-Pass Max Flat function. High-Pass operation is abbreviated HP and refers to the High-Pass function. In the event the Filter does not meet the correct tolerance as specified in each step of the Detailed Test Procedure, reference should be made to Section 4, Maintenance. Before using this detailed procedure, it is recommended that the output dc level of each channel be zeroed. This should be done after the Filter has been operating for at least one half hour with the dust covers in position.

- a. With the input shorted and the Filter in the High-Pass mode, adjust the output dc level front panel potentiometer R602 for zero output dc level.
- b. Set the mode of operation to Low-Pass Max Flat, adjust the output dc level front panel potentiometer R601 for zero output dc level.

When performing the test procedures of Table 2, observe the following:

- a. All measurements referring to LP mode are made in the "Max Flat" position.
- b. All voltages in RMS, unless otherwise noted.

### WARNING

This calibration procedure should be performed by qualified personnel only. Remove the covers before connecting the instrument to the AC source and use only insulated probes and/or tools.

Table 2. Detailed Test Procedure

STEP	PROCEDURE	SETTING				INPUT		LIMITS
		Freq. Decodes	Multi-plier	Mode	Gain	Frequency	Voltage	
1.	Pass-Band Gain 0 db, 100 Hz HP	100	0.01	HP	0	100 Hz	1.0	0.95 to 1.05 volts
2.	Pass-Band Gain 0 db, 100 Hz LP	100	100	LP	0	100 Hz	1.0	0.90 to 1.10 volts
3.	Pass-Band Gain 0 db, 1 kHz	100	0.01	HP	0	1 kHz	1.0	0.95 to 1.05 volts
4.	Pass-Band Gain 0 db, 100 kHz	100	100	HP	0	100 kHz	1.0	0.90 to 1.10 volts
5.	Pass-Band Gain 20 db, 100 kHz	100	100	HP	20	100 kHz	0.1	0.9 to 1.10 volts
6.	Pass-Band Gain 20 db, 1 kHz	100	0.01	HP	20	1 kHz	0.1	0.95 to 1.05 volts
7.	Pass-Band Gain 20 db, 100 Hz HP	100	0.01	HP	20	100 Hz	0.1	0.95 to 1.05 volts
8.	Pass-Band Gain 20 db, 100 Hz LP	100	100	LP	20	100 Hz	0.1	0.90 to 1.10 volts
9.	Low-Pass DC Gain	999	100	LP	0	DC	+1.0VDC	+0.9 to 1.10 volts DC
10.	High-Pass 1 MHz Bandwidth	100	10	HP	0	1 MHz	1.0	Greater than 0.6 volts
11.	Maximum Output Voltage 0 db	100	1	HP	0	1 kHz	5.0	Greater than 5.0 volts
Increase Oscillator Amplitude until Output Signal Begins to Distort. Measure Output Voltage Just Below Clipping.								
12.	Maximum Output Current	100	1	HP	0	1 kHz	5.0	Greater than 2.5 volts
Connect a 50-ohm Load Resistor Across Output. Adjust Oscillator Until Output Distorts. Remove Load.								
CALIBRATION								
13.	100 Hz X1 Band	100	1	HP	0	-	1.0	98 Hz to 102 Hz
Set Oscillator Approximately 5 Times Cutoff Frequency. Adjust Output to 0 db. Set Oscillator Frequency for Output Reading of -3 db, while maintaining input of Oscillator. Measure Frequency of Oscillator.								
14.	200 Hz X1 Band	200	1	HP	0	-	1.0	196 Hz to 204 Hz
Repeat the Procedure of STEP 13.								
15.	500 Hz X1 Band	500	1	HP	0	-	1.0	490 Hz to 510 Hz
Repeat the Procedure of STEP 13.								
16.	900 Hz X1 Band	900	1	HP	0	-	1.0	882 Hz to 918 Hz
Repeat the Procedure of STEP 13.								
17.	1 kHz X10 Band	100	10	HP	0	-	1.0	980 Hz to 1020 Hz
Repeat the Procedure of STEP 13.								
18.	5 kHz X10 Band	500	10	HP	0	-	1.0	4.9 kHz to 5.1 kHz
Repeat the Procedure of STEP 13.								
19.	9.00 kHz X10 Band	900	10	HP	0	-	1.0	8.82 kHz to 9.18 kHz
Repeat the Procedure of STEP 13.								
20.	90.0 Hz X.1 Band	900	0.1	HP	0	-	1.0	88.2 Hz to 918 Hz
Repeat the Procedure of STEP 13.								
21.	10 kHz X100 Band	100	100	HP	0	-	1.0	9.0 kHz to 11.0 kHz
Repeat the Procedure of STEP 13.								
22.	20 kHz X100 Band	200	100	HP	0	-	1.0	18.0 kHz to 22.0 kHz
Repeat the Procedure of STEP 13.								
23.	50 kHz X100 Band	500	100	HP	0	-	1.0	45.0 kHz to 55.0 kHz
Repeat the Procedure of STEP 13.								
24.	90.0 kHz X100 Band	900	100	HP	0	-	1.0	81.0 kHz to 990 kHz
Repeat the Procedure of STEP 13.								
Repeat steps 13 thru 24 with mode switch in LP position. Initial oscillator setting should be 1/5 of cutoff frequency instead of 5 times.								

Table 2. Detailed Test Procedure (Cont.)

STEP	PROCEDURE	SETTING				INPUT		LIMITS
		Freq. Decades	Multiplier	Mode	Gain	Frequency	Voltage	
25.	9.00 Hz X.01 Band	900	0.01	HP	0	9.00 Hz	3.0V p-p	2.0 to 2.2V p-p
Set Oscillator to 100 Hz. Set Output of Filter to 3.0 volts peak-to-peak. Set the Frequency of the Oscillator to that of the Cutoff Setting. Be sure the Amplitude of the Oscillator Remains Constant. Measure Amplitude of the Filter Output Signal.								
26.	0.999 Hz X.001 Band (3320 only)	999	0.001	HP	0	0.999 Hz	3.0V p-p	2.0 to 2.2V p-p
Repeat the Procedure of STEP 25.								
27.	Low-Pass R-C Check	100	1	LP RC	0	100 Hz	1.0	-15 db $\pm$ 2 db below Input level
28.	Maximum Attenuation LP	100	1	LP	0	1.1 kHz	5.0	Less than 500 microvolts
29.	Maximum Attenuation HP	100	100	HP	0	900 Hz	5.0	Less than 500 microvolts
CAUTION: Since the Third Harmonic Component of the Input Signal will be Nearly Unity Gain, it is Necessary to use an Oscillator with Low Distortion. Also, Since Many AC Meters are Capable of Measuring Signals at a Bandwidth Greater than 10 MHz, it is Necessary to Filter the Output Signal. In the Final Test of the Filter at Krohn-Hite the Output is Filtered by a Krohn-Hite Model 3202 Connected in a Band-Pass Configuration.								
30.	Hum & Noise-Bandwidth of Meter Limited to 100 kHz	100	X.1- X10	LP	0	-	-	Less than 500 microvolts
Short Input of Filter. Limit Bandwidth of Meter to 100 kHz.								
31.	Hum & Noise X100 Band - Bandwidth of Meter Limited to 100 kHz	100	100	HP	0	-	-	Less than 2 millivolts
32.	Hum & Noise - Bandwidth of meter limited to 10 MHz	100	X.1- X10	HP & LP	0	-	-	Less than 2 millivolts
Limit bandwidth of meter to 10 MHz.								
33.	Hum & Noise X100 Band - Bandwidth Limited to 10 MHz	100	100	HP	0	-	-	Less than 5 millivolts

