

# OPERATION MANUAL

---

## REGULATED DC POWER SUPPLY PMC-A SERIES

### TYPE I

**PMC 18-1A**  
**PMC 18-2A**  
**PMC 18-3A**

**PMC 35-0.5A**  
**PMC 35-1A**  
**PMC 35-2A**

### TYPE II

**PMC 18-5A**  
**PMC 35-3A**  
**PMC 70-1A**  
**PMC 110-0.6A**

**PMC 160-0.4A**  
**PMC 250-0.25A**  
**PMC 350-0.2A**  
**PMC 500-0.1A**

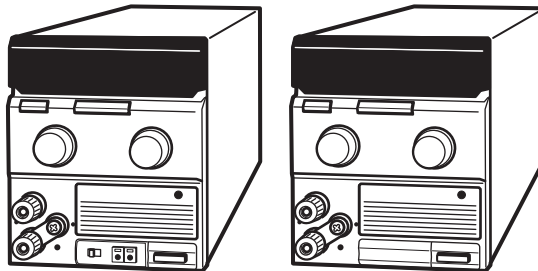

## Use of Operation Manual

Please read through and understand this Operation Manual before operating the product. After reading, always keep the manual nearby so that you may refer to it as needed.

If you find any misplaced or missing pages in this manual, they will be replaced. If the manual gets lost or soiled, a new copy can be provided for a fee. In either case, please contact Kikusui distributor/agent, and provide the “Kikusui Part No.” given on the cover.

This manual has been prepared with the utmost care; however, if you have any questions, or note any errors or omissions, please contact Kikusui distributor/agent.

Reproduction and reprinting of this operation manual, in whole or in part, without written permission is prohibited.

Both unit specifications and manual contents are subject to change without notice.

Copyright© 2009 Kikusui Electronics Corporation

## Power Requirements of this Product

Power requirements of this product have been changed and relevant sections of the Operation Manual should be revised accordingly. (Revision should be applied to items indicated by a check mark .)

### Input voltage

The input voltage of this product is \_\_\_\_\_ Vac,  
and the voltage range is \_\_\_\_\_ to \_\_\_\_\_ Vac. Use the product  
within this range only.

### Input fuse

The rating of this product's input fuse is \_\_\_\_\_ A, \_\_\_\_\_ Vac,  
and \_\_\_\_\_.















- **To avoid electrical shock, always disconnect the power cord or turn off the switchboard before attempting to check or replace the fuse.**
  - **Use a fuse element having a shape, rating, and characteristics suitable for this product. The use of a fuse with a different rating or one that short circuits the fuse holder may result in fire, electric shock, or irreparable damage.**
-



## Safety Symbols

For the safe use and safe maintenance of this product, the following symbols are used throughout this manual and on the product. Note the meaning of each of the symbols to ensure safe use of the product. (Not all symbols may be used.)

 or 	Indicates that a high voltage (over 1000 V) is used here. Touching the part causes a possibly fatal electric shock. If physical contact is required by your work, start work only after you make sure that no voltage is output here.
<b>DANGER</b>	Indicates an imminently hazardous situation which, if ignored, will result in death or serious injury.
 <b>WARNING</b>	Indicates a potentially hazardous situation which, if ignored, could result in death or serious injury.
 <b>CAUTION</b>	Indicates a potentially hazardous situation which, if ignored, may result in damage to the product and other property.
	Shows that the act indicated is prohibited.
	Indicates a general danger, warning, or caution. When this symbol is marked on the product, see the relevant sections in this manual.
	Indicates a caution for hot surface of the product. When this symbol is marked on the product, see the relevant sections in this manual.
	Protective conductor terminal.
	Chassis (frame) terminal.
	On (supply)
	Off (supply)
	In position of a bi-stable push control
	Out position of a bi-stable push control





## Safety Precautions

The following safety precautions must be observed to avoid fire hazards, electric shock, accidents, and other failures. Keep them in mind and make sure to observe them.

Using the product in a manner that is not specified in this manual may impair the protection functions provided by the product.

### Users



- This product must be used only by qualified personnel who understand the contents of this operation manual.
- If unqualified personnel is to use the product, be sure the product is handled under the supervision of qualified personnel (those who have electrical knowledge). This is to prevent the possibility of personal injury.

### Purpose of use



- Never use the product for purposes other than the product's intended use.
- This product is not designed or manufactured for general home or consumer use.

### Input power

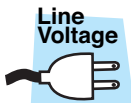

- Use the product within the rated input power voltage range.
- For applying power, use the power cord provided. For details, see the respective page in the operation manual.
- This product is designed as an equipment of IEC Overvoltage Category II (energy-consuming equipment supplied from the fixed installation).

### Fuse







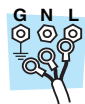

- The fuse can be replaced with a new one. When replacing a fuse, use the one which has appropriate shape, ratings, and specifications. For details, refer to the specification section in this manual.

### Cover



- Some parts inside the product may cause physical hazards. Do not remove the external cover.
- When the product is under the operation, the surface of top cover may get high temperature. It may cause burn on the skin.

<p><b>Grounding</b></p> 	<ul style="list-style-type: none"> <li>• This product is an IEC Safety Class I equipment (equipment with a protective conductor terminal). To prevent the possibility of electric shock, be sure to connect the protective conductor terminal of the product to electrical ground (safety ground).</li> </ul>
<p><b>Installation</b></p> 	<ul style="list-style-type: none"> <li>• This product is designed for safe indoor use. Be sure to use it indoors.</li> <li>• When installing this product, be sure to observe the description in 2.2 Precautions Concerning Installation Location in this manual.</li> </ul>
<p><b>Relocation</b></p> 	<ul style="list-style-type: none"> <li>• Turn off the POWER switch, and disconnect all cables before relocating the product.</li> <li>• When relocating the product, be sure to include the manual.</li> </ul>
<p><b>Operation</b></p> 	<ul style="list-style-type: none"> <li>• If a malfunction or abnormality is detected on the product, stop using it immediately, and remove the power plug from the outlet. Make sure the product is not used until it is completely repaired.</li> <li>• Use cables or wires with sufficiently large current capacity for output wires and load cables.</li> <li>• Do not disassemble or modify the product. If you need to modify the product, contact your Kikusui distributor/agent.</li> </ul>
<p><b>Maintenance and inspection</b></p> 	<ul style="list-style-type: none"> <li>• To prevent the possibility of electric shock, make sure to unplug the power plug before carrying out maintenance or inspection. Do not remove the external cover during maintenance or inspection.</li> <li>• Check that the insulation coating of the power cord is not broken and that the plug is not cracked or falling apart.</li> <li>• If the panel needs cleaning, gently wipe using a soft cloth with water-diluted neutral detergent.</li> <li>• To maintain the performance and safe operation of the product, it is recommended that periodic maintenance, inspection, cleaning, and calibration be performed.</li> </ul>
<p><b>Service</b></p> 	<ul style="list-style-type: none"> <li>• Kikusui service engineers will perform internal service on the product. If the product needs adjustment or repairs, contact your Kikusui distributor/agent.</li> </ul>

# How to Read This Manual

## Preface

Thank you for purchasing the PMC-A Series regulated DC power supply.

This manual is intended for first-time users of the PMC-A Series (hereafter abbreviated as: the PMC-A). It gives an overview of the PMC-A and describes various settings, operation, maintenance, safety precautions, etc.

Read this manual thoroughly to use the functions of the PMC-A effectively. You can also review this manual; when you are confused about an operation or when a problem occurs.

## How to read this manual

This manual is designed to be read from beginning to end. We recommend that you read the manual thoroughly from the beginning before using the PMC-A for the first time.

## Intended readers of this manual

This manual is intended for those using the PMC-A of regulated DC power supply and teaching other users on how to operate the PMC-A.



It assumes that the reader has knowledge of a regulated DC power.





## Notations used in this manual

The following marks are used with the corresponding explanations in this manual.

 <b>WARNING</b>	Indicates an imminently hazardous situation which, if ignored, could result in death or serious injury.
 <b>CAUTION</b>	Indicates a potentially hazardous situation which, if ignored, may result in damage to the product and other property.
<b>NOTE</b>	Indicates information that you should know.
<b>DESCRIPTION</b>	Explanation of terminology or operation principle.
 <b>See</b>	Indicates reference to detailed information.

# Contents

- Safety Symbols -----5
- Safety Precautions -----6
- How to Read This Manual -----8
- Contents -----10
- Function index -----13
- Front panel -----14
- Rear Panel -----16

## Chapter 1 General Description

- 1.1 About This Manual -----17
- 1.2 Product Overview -----17
- 1.3 Features -----18
- 1.4 Options -----19

## Chapter 2 Installation and Preparation

- 2.1 Checking the Package Contents -----23
- 2.2 Precautions Concerning Installation Location -----24
- 2.3 Precautions to Be Taken When Moving the Product ---26
- 2.4 Rack-mount Adaptor Installation -----26
- 2.5 Connecting the Power Cord -----27
- 2.6 Ground (Earth) -----28
- 2.7 Turning On the Power -----29
  - Inrush Current -----30
  - Reverse Polarity -----30

## Chapter 3 Connecting the Load

- 3.1 Load Considerations -----31
  - 3.1.1 When the Load Current Has Peaks or is Pulse-shaped -----31
  - 3.1.2 When the Load Generates a Reverse Current to the Power Supply -----32
  - 3.1.3 When the Load Has Accumulated Energy Such As Batteries -----32
- 3.2 Connecting the Load -----33
  - 3.2.1 Load Cable -----34
    - Current capacity of the load cable -----34

Dependence of allowable cable current on the maximum allowable insulator temperature ----- -34  
 Taking measures against noise ----- -35  
 Voltage rating of the load cable ----- -35  
 3.2.2 Connecting to the Output Terminal ----- -35

**Chapter 4 Basic Operation**

4.1 Constant Voltage (CV) and Constant Current (CC) Power Supplies ----- -37  
     Crossover point ----- -39  
     Example of CV/CC mode operation ----- -39  
 4.2 Using the Power Supply as a Constant Voltage Power Supply ----- -40  
     Output Setup Procedure ----- -40  
 4.3 Using the Power Supply as a Constant Current Power Supply ----- -40  
     Output Setup Procedure ----- -40  
 4.4 Protection Function ----- -41  
     4.4.1 Overvoltage Protection (OVP) Function ----- -41  
         Setup procedure of the OVP trip point ----- -41  
         Clearing alarms ----- -42  
     4.4.2 Overheat Protection (OHP) Function ----- -42  
     4.4.3 Other Protection Functions ----- -42  
 4.5 Remote Sensing ----- -43  
     Handling of SENSING terminals ----- -43  
     Connection and setup procedure ----- -44  
 4.6 Master-Slave Parallel Operation ----- -45  
     Handling of J1 Terminal ----- -45  
     4.6.1 Functions during Master-Slave Parallel Operation - -46  
         Connection and setup procedure ----- -47  
         Starting and ending parallel operation ----- -48  
 4.7 Series Operation ----- -51  
     Maximum number of power supplies connected in series -  
         ----- -52  
     4.7.1 Functions during Series operation ----- -52  
         Connection and setup procedure ----- -53  
         Starting and ending series operation ----- -53

**Chapter 5 External Control**

5.1 External Remote Control ----- -55

- J2 connector ----- -56
- 5.1.1 Remote Control Connection and Setup ----- -59
  - Controlling the output voltage using external voltage -- -60
  - Controlling the output voltage using external resistance -61
  - Controlling the output current using external voltage -- -61
  - Controlling the output current using external resistance -62
  - Output on/off control ----- -63
- 5.2 Remote Monitoring ----- -63
  - 5.2.1 External Monitoring of the Output Voltage and Output Current. ----- -63
  - 5.2.2 External monitoring of the operating status ----- -64

**Chapter 6 Maintenance**

- 6.1 Replacing the Fuse ----- -66
- 6.2 Calibration ----- -67
  - Test equipment required for calibration ----- -67
  - Environment ----- -67
  - Calibration Procedure ----- -67
  - Voltage system calibration procedure ----- -68
  - Current system calibration procedure ----- -71

**Chapter 7 Specifications**

- 7.1 Specifications (Type I) ----- -75
- 7.2 Specifications (Type II) ----- -80
- 7.3 Dimension Diagram ----- -85



## Function index

### Preparation

Usage scenarios	Manual sections	 page
Confirming accessories	2 Installation and Preparation	23
Rated input values - quantities	2.5 Connecting the Power Cord 7 Specifications	27 74
What may be used with power supply connected to load	3.2 Connecting the Load	34
Precautions for connecting to remote sensing lines	4.5 Remote Sensing	43
Necessary preparations for rack mounting	1.4 Options 2.4 Rack-mount Adaptor Installation 7 Specifications	19 26 74

### Use

Usage scenarios	Manual sections	 page
Learning protection details	4.4 Protection Function	41
Learning available function	1.3 Features	18
Clearing alarm conditions immediately.	4.4 Protection Function	41

1

2

3

4

5

6

7

## Front panel

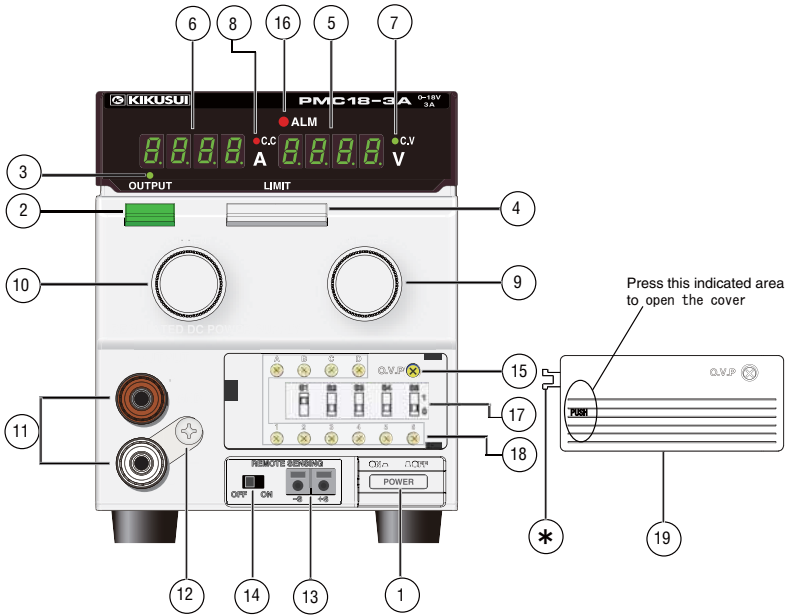

No.	Name	Description	<a href="#">See page</a>
1	POWER switch	Depressed position is ON	29
2	OUTPUT switch	Depressed position is ON. When this switch is turned OFF, the OUTPUT of the power supply is at high impedance (several k $\Omega$ ).	40
3	OUTPUT LED	Lights when the output is ON. (Green)	—
4	LIMIT switch	The voltage and current settings are displayed while this switch is held down. This switch only displays the current setting. It is not a memory function.	40
5	Voltmeter	Displays the voltage.	—
6	Ammeter	Displays the current.	—
7	C.V LED	Lights when operating in constant voltage (CV) mode. (Green)	40

No.	Name	Description	See page
8	C.C LED	Lights when operating in constant current (CC) mode. (Red)	40
9	VOLTAGE knob	Sets the output voltage. (10 turns)	—
10	CURRENT knob	Sets the output current. (10 turns)	—
11	OUTPUT terminal	Red : + (positive) terminal White : - (negative) terminal Connect either output terminal to the GND terminal using the short bar unless your application requires the power supply output to be floating. Since Type II models use a relay switch system, a relay switch noise may appear at the rising edge of the output when the input voltage is low or depending on the load condition.	35
12	GND terminal	Connected to the chassis of the power supply.	—
13	SENSING terminal *1	Remote sensing terminal.	43
14	SENSING switch *1	Enables remote sensing. Turn off the switch when you are not using remote sensing.	43
15	OVP variable resistor	Sets the OVP (Overvoltage Protection) trip point.	41
16	ALM LED	Lights when the overvoltage or overheat protection circuit strips entering an alarm status. (Red)	41
17	S1 to S4 switches	Used for analog remote control.	56
	S5 switch	Used for master-slave parallel control.	
18	Variable resistor for calibration	Used to calibrate the output voltage and the meter.	67
19	Front sub-panel cover	To open the cover, press the part indicated as PUSH. You can remove the cover by pulling the opened cover. Even if the claw (indicated with ⊗) breaks, the cover can be attached without problem.	—

\*1 Not available on models with rated output of 70 V or higher.



## Rear Panel

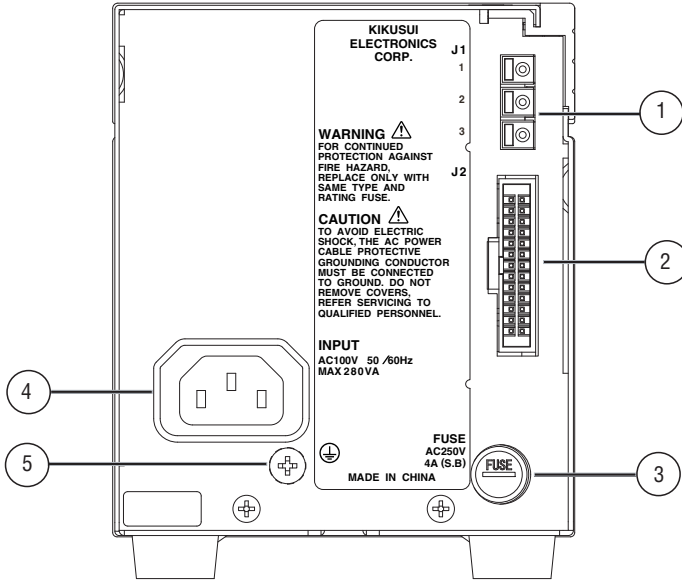

No.	Name	Description	<a href="#">See page</a>
1	J1 connector	Input/output terminals for master slave parallel operation.	43 45
2	J2 connector	Terminals for analog remote control and monitoring function.	56
3	Fuse holder	Contains an AC input fuse (S.B type)	66
4	INPUT connector	Power cord connector for supplying power to the power supply.	27
5		Protective conductor terminal. Always ground the power supply.	28





# General Description

---

This chapter gives an overview and introduces the features of the PMC-A Series.

## 1.1 About This Manual

The PMC-A series come in two types depending on the size of case. This operation manual describes the following models.

### ■ Type I

PMC18-1A, PMC18-2A, PMC18-3A, PMC35-0.5A,  
PMC35-1A, PMC35-2A

### ■ Type II

PMC18-5A, PMC35-3A, PMC70-1A, PMC110-0.6A,  
PMC160-0.4A, PMC250-0.25A, PMC350-0.2A,  
PMC500-0.1A

## 1.2 Product Overview

The PMC-A Series are compact, high-performance, constant voltage, constant current Series regulated DC power supplies. The adoption of Series regulated design realizes a highly stable output with a low level of output noise. In addition, with an optional power supply controller, it allows to operate via GPIB systems which offers wide application in the field of R&D, Manufacturing, Testing, etc.

---

## 1.3 Features

- Digital display on both voltage and current at the same time.

The PMC-A series power supply has two bright LED meters that display the output voltage, output current, and their settings.

- High-resolution setting for output voltage and current.

The variable resistors for the output voltage and current settings are 10-turn wire wound type, allowing high-resolution settings.

- Output ON/OFF by external contact

The output ON/OFF switch is an electronic switch that emits no chattering or noise. The switch can also be controlled remotely.

- External Remote Control

The output voltage and current can be controlled remotely using an external analog signal (voltage or resistance). By connecting a power supply controller such as KIKUSUI's PIA3200 or PIA4810 via the GPIB interface, the PMC-A series power supply can be integrated into a system such as an automated test system.

- External monitor function

The monitor output enables to monitor the status output, output voltage, and output current from outside of the PMC-A.

- Remote sensing function

The remote sensing function stabilizes the output voltage across the load. (equipped with 18 V, 35 V models)

- Equipped with overvoltage protection (OVP) function as standard.

---

### NOTE

- To control the PMC-A series power supply using KIKUSUI's PIA3200 (via the GPIB interface), the ROM version of the PIA3200 must be 1.03 or later. If not, the

ROM needs to be upgraded. To have the ROM upgraded, contact your Kikusui agent or distributor.

- On Type II models, the internal loss is decreased by changing the input voltage of the series regulator. The input voltage is changed by switching secondary taps of the internal transformer using relays. The relay has three switch points and changes depending on the input voltage. If the input voltage fluctuates when the output voltage of power supply is used near a relay switch point, you may hear the sound of the relay switching. This is not a malfunction. When the relay is switched, a spike voltage at the output voltage may be generated.

## 1.4 Options

The following options are available for the PMC-A series.  
For details, contact your Kikusui agent or distributor.

### ■ Guard cap (GP01-PMC)



Exchanged with the knob to prevent inadvertent operation of voltage or current setting.

### ■ Output terminal cover (OTC01-PMC)

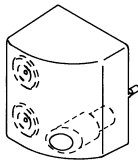

Covers the output terminal to prevent unexpected accidents. Applies to models with a rated output of 70 V or greater.

It is recommended that you use the output terminal cover for your safety.

---

## ■ Handle (CH01-PMC)

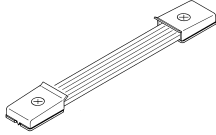

A convenient handle for carrying the power supply.

Applies to all type II models.

## ■ Rack mount options

The following options are available for rack mount system.

Name	Model	Note
Rack adapter	KRA3	inch rack (EIA standard)
	KRA150	Milli rack (JIS standard)
Blank panel	KBP3-2	(EIA, JIS common) - 1/2 width
	KBP3-4	(EIA, JIS common) - 1/4 width
	BP191(-M) <sup>*1</sup>	inch rack (EIA standard)
	BP1H(-M) <sup>*1</sup>	Milli rack (JIS standard)

\*1. the model added with “-M” is “mesh” type.

---

### CAUTION

- The PMC-A power supply uses unforced air cooling. In order to keep a space for cooling intake, at least one layer★ of “blank panel” must be installed when the PMC-A is rack mounted.

★JIS standard : 50 mm、 EIA standard : 44.45 mm

---

For details, contact your Kikusui agent or distributor.



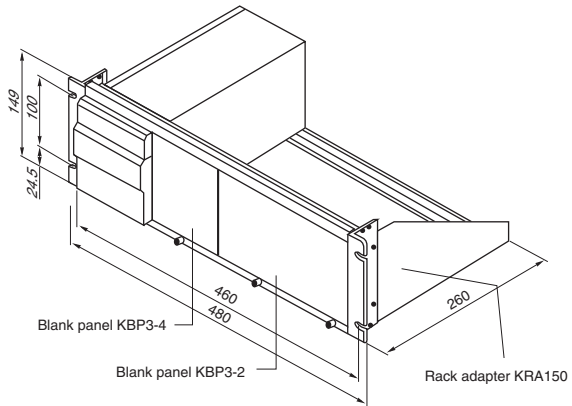
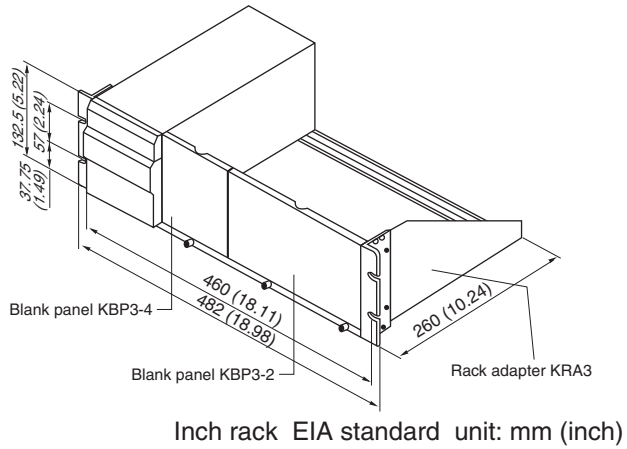

Fig. 1-1 Example of installation for rack mount options

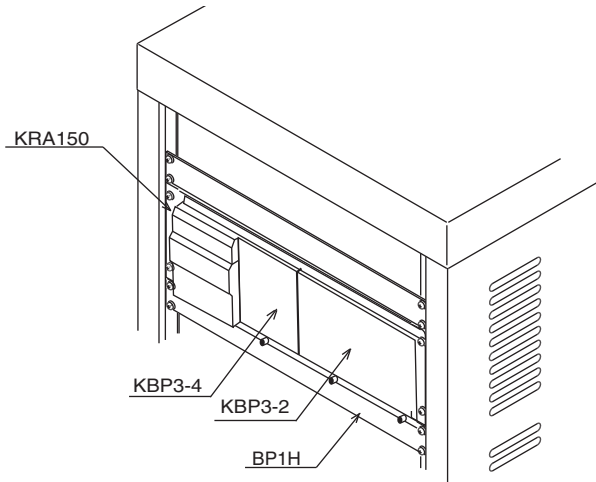

Fig. 1-2 Rack mounting example

This chapter explains how to prepare the PMC-A for use from unpacking to installation.

## 2.1 Checking the Package Contents

When you receive the PMC-A, check that all accessories are included and that the accessories have not been damaged during transportation.

If any of the accessories are damaged or missing, contact your Kikusui agent or distributor.

We recommend that all packing materials be saved, in case the PMC-A needs to be transported at a later date.

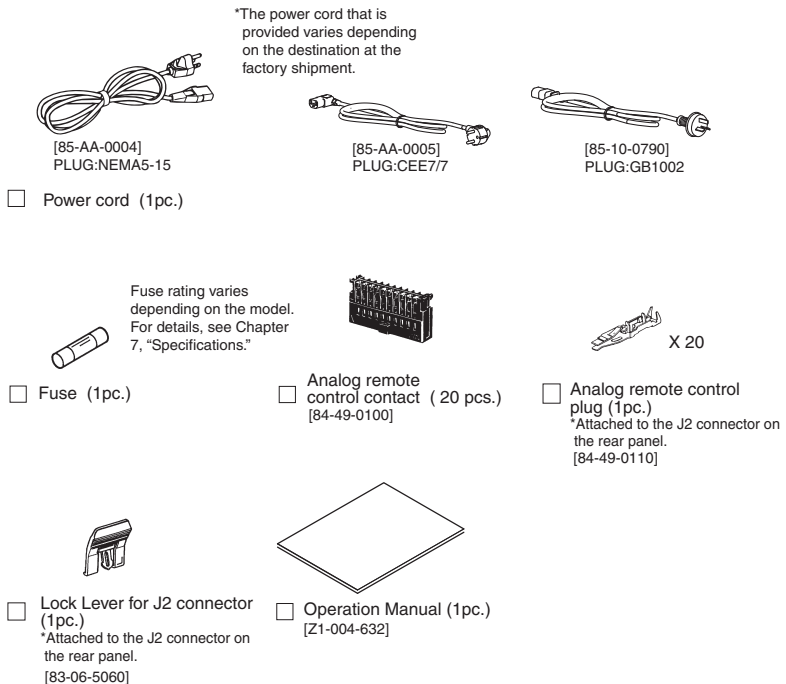

Fig. 2-1 Accessories

---

## 2.2 Precautions Concerning Installation Location

Be sure to observe the following precautions when installing the PMC-A.

- Do not use the product in a flammable atmosphere.

To prevent the possibility of explosion or fire, do not use the product near alcohol, thinner or other combustible materials, or in an atmosphere containing such vapors.

- Avoid locations where the product is exposed to high temperature or direct sunlight.

Do not place the product near a heater or in areas subject to drastic temperature changes.

Operating temperature range: 0 °C to 40 °C (32 °F to 104 °F)

Storage temperature range: -10 °C to 60 °C (14 °F to 140 °F)

- Avoid humid environments.

Do not place the product in high-humidity locations-near a boiler, humidifier, or water supply.

Operating humidity range: 10 %rh to 80 %rh  
(no condensation)

Storage humidity range: less than 90 % rh  
(no condensation)

Condensation may occur even within the operating relative humidity range. In such cases, do not use the product until the condensation dries up completely.

- Be sure to use it indoors.

The PMC-A is designed for safe indoor use.

- Do not place the product in a corrosive atmosphere.

Do not install the product in a corrosive atmosphere or in environments containing sulfuric acid mist, etc. This may cause corrosion of various conductors and bad contacts of connectors leading to malfunction and failure, or in the worst case, a fire.





However, operation in such environments may be possible through alteration. If you wish to use the product in such environments, consult your Kikusui agent or distributor.

- Do not place the product in a dusty location.

Accumulation of dust can lead to electric shock or fire.

- Do not use the product where ventilation is poor.

The power supply uses unforced air cooling. The air flows from the bottom panel to the top panel. Do not block the bottom and top panels.

The top cover of the product may get high temperature, it may cause burn on the skin.

Do not install the power supply with the side or front panel facing up or down.

- Do not place objects on top of the product.

Placing heavy objects on the product may cause malfunction of the power supply.

Do not stack the power supplies.

- Do not place the product on an inclined surface or location subject to vibrations.

The product may fall or tip over causing damages and injuries.

- Do not use the product in a location where strong magnetic or electric fields are nearby or a location where large amount of distortion and noise is present on the input power supply waveform.

The product may malfunction and cause electric shock or fire.

- Do not use the product near highly sensitive measuring instruments or transceivers.

The noise generated by the product may affect them.

---

## 2.3 Precautions to Be Taken When Moving the Product

When moving the product to the installation location or when transporting the product, note the following points.

- Turn off the POWER switch.

Moving the product while the power is turned on can cause electric shock or damage to it.

- Remove all wiring.

Moving the product with the cables connected can cause wires to break or injuries due to the product falling over.

- When transporting the product, be sure to use the original packing materials.

Otherwise, damage may result from vibrations or from the product falling during transportation.

- Make sure this manual has been included.

## 2.4 Rack-mount Adaptor Installation

 p.19

Before installing the rack-mount adaptor, remove the plastic feet. How to remove plastic feet is illustrated in Fig. 2-2.

Concerning installation, refer to the KRA3 or the KRA150 installation instructions.

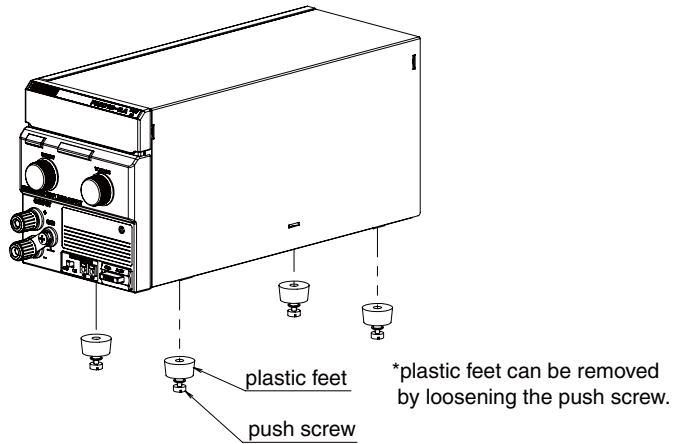

Fig. 2-2 Removing plastic feet

In case the PMC-A is detached from the rack adaptor, we recommend that you keep all the parts.

When you attach the plastic feet again, use the parts which were removed.

## 2.5 Connecting the Power Cord

The PMC-A is designed as an equipment of IEC Overvoltage Category II (energy-consuming equipment supplied from the fixed installation).

### NOTE

- To connect to the AC line, use the attached power cord.
- The power cord with a plug can be used to disconnect the PMC-A from the AC line in an emergency. Connect the power plug to an easily accessible power outlet so that the plug can be removed from the outlet at any time. Be sure to allow enough space around the power outlet.
- Do not use the attached power cord as the power cord for other equipment.

1. Check that the AC line to be connected is compatible with the product's rated input value.

The product's nominal input rating is shown on the rear panel. When it is filled in, as in Fig. 2-3, the line voltage will be 100 V. Input can be within  $\pm 10\%$  of the nominal input voltage shown. The frequency can be 50 Hz or 60 Hz.

2. Turn off the POWER switch.
3. Connect the power cord to the AC inlet (AC INPUT) on the rear panel.
4. Insert the power plug to an outlet.

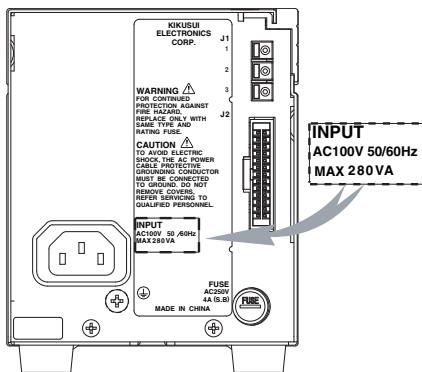

Fig. 2-3  
Confirmation  
of nominal  
input rating

## 2.6 Ground (Earth)



- **Possible electric shock.** The PMC-A is an IEC Safety Class I equipment (equipment with a protective conductor terminal). Be sure to ground the product to prevent electric shock.

Be sure to ground the unit for your safety.

Securely connect the protective conductor (earth) terminal on the rear panel.



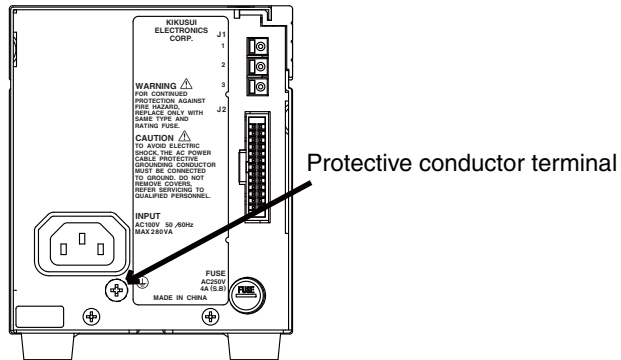

Fig. 2-4 Confirmation of ground (protective conductor terminal)

## 2.7 Turning On the Power

Before turning on the POWER switch, be sure to observe the status of OUTPUT switch. It is on when the switch is pressed position, and it is off when the switch is depressed position.

- 
- ⚠ CAUTION** • If the POWER switch is turned on while the OUTPUT switch remains on, a preset voltage or current is supplied to the load.
- 

1. Check that the OUTPUT switch is turned off.
2. Open the sub-panel cover of the front panel to confirm that all levers of control switch (S1 to S5) are set to the up position (1).
3. Check that the Remote sensing switch on the front panel is turned off.
4. Turn on the POWER switch.  
The LED on the control panel lights up.

- 
5. While pressing the LIMIT switch, and turn the VOLTAGE control knob; check that the output voltage can be preset in a range from zero to the rated output voltage value.
  6. While pressing the LIMIT switch, and turn the CURRENT control knob; check that the output current can be preset in a range from zero to the rated output current value.

Now, the PMC-A is ready for use.

### Inrush Current

When the power switch is turned on, the maximum inrush current of 30 A for type I and 80 A for type II may flow. In particular, with a system using multiple units of the PMC-A, when the power switch is turned on at the same time, make sure that there is enough of a margin, taking into consideration the capacity of the power distributor panel or the AC power line.

### Reverse Polarity

When the current or voltage is set up as zero with the OUTPUT switched off, a 0 V to 0.6 V reverse polarity voltage can arise. Because of this voltage, an opposite-directed 1 mA current flows to the load. Note that this load can reduce the life time of the product.



This chapter describes the consideration to be given to the load, explains how to connect the load wires, and explains how to connect to the output terminal.

## 3.1 Load Considerations

Note that the output will become unstable if the following types of loads are connected.

- When the load current has peaks or is pulse-shaped
- When the load generates a reverse current to the power supply
- When the load has accumulated energy such as batteries

### 3.1.1 When the Load Current Has Peaks or is Pulse-shaped

The current meter on the PMC-A indicates only mean values. Even when the indicated value is less than the preset current value, the peak values may actually exceed the preset current value. In such cases, the PMC-A is instantaneously put into constant-current operation mode, and the output voltage drops accordingly.

For these types of loads, you must increase the preset current value or increase the current capacity.

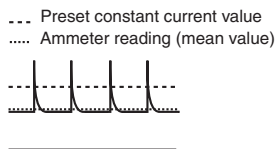

Fig. 3-1 Load current with peaks

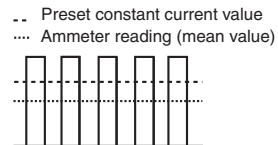

Fig. 3-2 Pulse shaped load current

### 3.1.2 When the Load Generates a Reverse Current to the Power Supply

The PMC-A cannot absorb reverse current from the load. Therefore, if a regenerative load (such as an inverter, converter, or transformer) is connected, the output voltage increases and becomes unstable.

For these types of loads, connect a resistor  $R_D$  as shown in Fig. 3-3 "Remedy for regenerative load" to bypass the reverse current. However, the amount of current to the load decreases by  $I_{rp}$ .

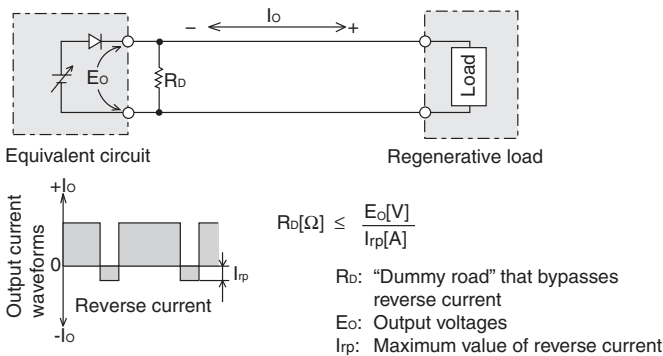

Fig. 3-3 Remedy for regenerative load

**CAUTION**

- For resistor  $R_D$ , select an appropriate resistor rated for the power (allowing sufficient margin).
- If a resistor with insufficient rated power for the circuit is used,  $R_D$  may burn out.

### 3.1.3 When the Load Has Accumulated Energy Such As Batteries

When connecting to a load that has stored energy such as a battery, a large current flows from the load to the product's internal capacitor through a protection diode in an internal output con-



trol circuit, and depending on the situation, the product may burn out or the load's working life may be reduced.

For any such load, connect a reverse current protection diode DRP in series between the PMC-A and the load, as shown in Fig. 3-4 "Remedy against load with accumulated energy".

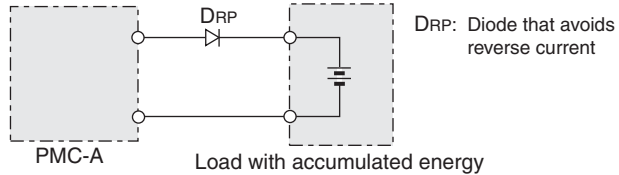

Fig. 3-4 Remedy against load with accumulated energy

- ⚠ CAUTION**
- To protect the load and the PMC-A, select DRP according to the following criteria.
    - Reverse voltage withstand capacity: At least twice the rated output voltage of the power supply.
    - Forward current capacity: Three to ten times the rated output current of the power supply.
    - A diode with small loss.
  - Be sure to take into account the heat generated by DRP. DRP may burn out if heat dissipation is inadequate.

### 3.2 Connecting the Load

This section describes the wire used to connect the PMC-A to the load, and the connection to the output terminal.

- ⚠ CAUTION**
- Before connecting to the load, confirm that the POWER switch is turned on, and that the OUTPUT is turned off.

## 3.2.1 Load Cable



- **To prevent the possibility of fire, use a load cable with sufficient current capacity with respect to the rated output current of the PMC-A.**
- **To prevent the possibility of electric shock, use a load cable with a higher voltage rating than the isolation voltage of the PMC-A.**  
**For the isolation voltage, see chapter 7, “Specifications”.**

### Current capacity of the load cable

Load cables must be rated to carry the maximum rated output current of the PMC-A. If their current rating exceeds the maximum rated output current, the cable will remain intact even if the load is short-circuited.

Table 3-1 Nominal cross-sectional area of cables and allowable currents

Nominal cross sectional area [mm <sup>2</sup> ]	AWG	(Reference cross sectional area) [mm <sup>2</sup> ]	Allowable current *1 [A] (Ta = 30 °C)	Current recommended by Kikusui [A]
0.9	18	(0.82)	17	4
1.25	16	(1.31)	19	6
2	14	(2.08)	27	10
3.5	12	(3.31)	37	-
5.5	10	(5.26)	49	20

\*1. Excerpts from Japanese laws related to electrical equipment

When there is a long distance to the load, use as thick a line as possible, more than recommended.

### Dependence of allowable cable current on the maximum allowable insulator temperature

The temperature of a cable is determined by the resistance loss due to the flowing current, ambient temperature and the thermal

resistance with respect to the outside of the cable. The allowable current in Table 3.1 "Load Considerations" show the current capacities that can be flowed through a heat-resistant PVC wire (single wire) with a maximum allowable temperature of 60 °C when the wire is stretched horizontally under an ambient temperature of 30 °C. The current capacity should be lower when the heat resistant temperature of the PVC wire is lower, the ambient temperature is higher than 30 °C or the heat radiation is degraded due to the use of bundled wires.

### Taking measures against noise

It is better to make heat radiation as great as possible to allow a larger current to flow, when wires having the same heat-resistant temperature are installed. For measures against noise in the load cables, however, installing the + (pos.) and – (neg.) output lines side by side or bundling them together is more effective against unwanted noise. The Kikusui-recommended currents shown in Table 3-1 "Nominal cross-sectional area of cables and allowable currents" are allowable current that have been reduced in consideration of the potential bundling of load cables. Use these values as a guideline when installing load wires.

### Voltage rating of the load cable

Use a load cable with a higher voltage rating than the isolation voltage of the PMC-A. For the isolation voltage of each model, see Chapter 7 "Specifications".

## 3.2.2 Connecting to the Output Terminal



- **To prevent the possibility of electric shock, be sure to turn off the POWER switch.**

1. Turn off the POWER switch.
2. Connect the load cable to the output terminal.

To secure the firm connection, use the crimping terminal for the load cable to the output terminal.

### 3. Check the connection.

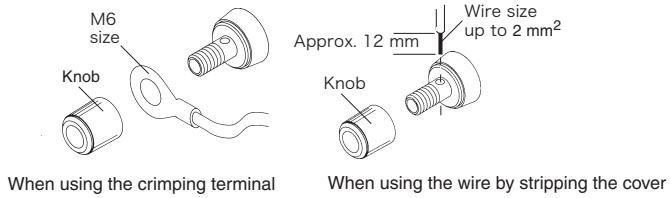

Fig. 3-5 Connecting to the output terminal

This chapter describes basic features and operations of the PMC-A such as remote sensing, master-slave parallel operation, series operation.

## 4.1 Constant Voltage (CV) and Constant Current (CC) Power Supplies

The product has functions for constant voltage power supply to maintain a fixed/regularized output voltage, and for constant current power supply that maintain a fixed output current, even as the load changes. The state of operation for constant voltage supply is called “CV mode”, and for constant current supply, “CC mode”. These operating modes are determined by the following three values.

- Output voltage setup value ( $V_s$ )
- Output current setup value ( $I_s$ )
- Load resistance value ( $R_L$ )

These operations are detailed in the following.

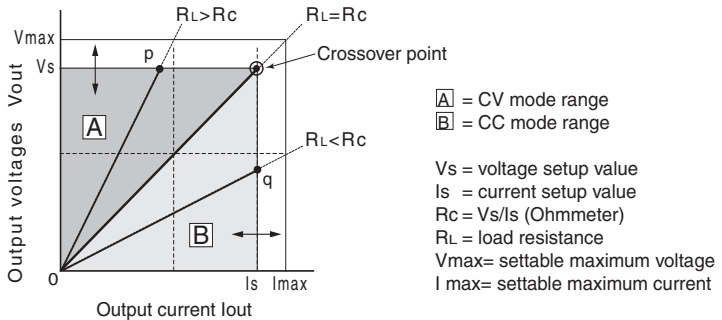

Fig. 4-1 Constant voltage operation and constant current operation

---

Fig. 4-1 illustrates the operating modes for the PMC-A.  $R_L$  stands for the load resistance value, and  $R_C$  stands for the resistance value calculated from the current and the voltage setup value ( $R_C = V_s/I_s$ ). The regulated power supply is designed as operating in CV mode when the operating point is in the [A] range, and in CC mode when the operating point is in the [B] range. The straight line ( $R_L = R_C$ ) is a line between CV mode and CC mode. This line shows loads for which the output voltage and the setup voltage are equalized, or which the output current and the setup current are equalized. If load resistance  $R_L$  is greater than load resistance  $R_C$ , the power supply operates in CV mode because the operating point is within the [A] range. At this time, the current setup value  $I_s$  becomes the current limit value.

When operating in CV mode, the output voltage is maintained at the voltage setup value. The output current is determined by the relation  $I = V_s/R_L$ , and is reduced to a value below the current limit value  $I_s$ . Note that the current of the setup value does not flow at this time.

For the loads to allow transient peak current flow, the current limit value must be set so that the peak current does not reach the limit value.

Conversely, if load resistance  $R_C$  is greater than load resistance  $R_L$ , the power supply operates in CC mode because the operating point is within the [B] range. At this time, the voltage setup value  $V_s$  becomes the voltage limit value.

When operating in CC mode, the output current is maintained at an established current value. The output voltage is determined by the relation  $V = I_s \times R_L$ , and is reduced to a value below the current limit value  $V_s$ . Note that the voltage of the setup value is not applied at this time.

For the loads in which transitory surge voltage arises, the voltage limit value must be set so that the surge voltage does not reach the voltage limit value.

## Crossover point

The unit switches between CV mode and CC mode automatically depending on the load. The points where the transition occurs are called crossover points.

For example, in CV mode, when the load changes and the output current reaches the current limit value, there is an automatic transition to CC mode in order to protect the load. Similarly, in CC mode, when the output voltage reaches the voltage limit value, there is an automatic transition to CV mode.

## Example of CV/CC mode operation

The following describes an example of model PMC35-1A. (rated output voltage 35 V and rated output current 1 A).

Connect an  $60\ \Omega$  load resistance ( $R_L$ ) to the power supply's output terminal and set the output voltage to 20 V and the output current to 0.5 A. In this case, because  $R_c = 20\text{ V} / 0.5\text{ A} = 40\ \Omega$ , and  $60\ \Omega > 40\ \Omega$  ( $R_L > R_c$ ), CV mode is activated. When the voltage rises while still in CV mode, because  $V_s = 0.5\text{ A} \times 60\ \Omega = 30\text{ V}$  ( $V_s = I_s \times R_L$ ), the voltage can go up to 30 V. When the voltage goes higher than this value, the crossover point is reached, and there is an automatic transition to CC mode. To maintain CV mode at rate exceeding 30 V, raise the output current setting value (0.5 A).

Next, connect a  $25\ \Omega$  load resistor ( $R_L$ ) to the power supply's output terminal, and establish a 20 V output voltage and a 0.5 A output current. In this case, CC mode is activated because  $R_c = 20\text{ V} / 0.5\text{ A} = 40\ \Omega$  and  $25\ \Omega < 40\ \Omega$  ( $R_L < R_c$ ). When the current rises while still in CC mode, it is possible that the current value will rise to a level higher than  $I_s = V_s / R_L$  up to  $I_s = 20\text{ V} / 25\ \Omega = 0.8\text{ A}$ . When the current goes higher, it reaches the crossover point, and there is an automatic transition to CV mode. To maintain CC mode at rate exceeding 0.8 A, raise the output voltage setting value (20V).

---

## 4.2 Using the Power Supply as a Constant Voltage Power Supply

### Output Setup Procedure

1. Check that the OUTPUT switch is off and turn on the POWER switch.
2. While holding down the LIMIT switch, set the appropriate current for the load using the CURRENT knob.  
The value entered here becomes the current limit.
3. While holding down the LIMIT switch, set the required voltage using the VOLTAGE knob.
4. Turn on the OUTPUT switch.  
C.V LED lights indicating that the power supply is in constant voltage operation.

---

**NOTE**

- If the output current exceeds the current limit that was specified in step 2 due to load fluctuations when the power supply is operating in constant voltage mode, the power supply switches to constant current mode. When the power supply switches to constant current mode, C.C LED lights up.
- 

## 4.3 Using the Power Supply as a Constant Current Power Supply

### Output Setup Procedure

1. Check that the OUTPUT switch is off and turn on the POWER switch.
2. While holding down the LIMIT switch, set the allowable voltage using the VOLTAGE knob.  
The value entered here becomes the voltage limit.



3. While holding down the LIMIT switch, set the required current using the CURRENT knob.
4. Turn on the OUTPUT switch.

If the load is connected, C.C LED lights indicating that the power supply is in the constant current operation.

**NOTE**

- If the output voltage exceeds the voltage limit that was specified in step 2 due to load fluctuations when the power supply is operating in constant current mode, the power supply switches to constant voltage mode. When the power supply switches to constant voltage mode, C.V LED lights up.

## 4.4 Protection Function

The PMC-A is equipped with the following protection function.

### 4.4.1 Overvoltage Protection (OVP) Function

The overvoltage protection (OVP) function protects the load from unexpected and excessive voltage. When overvoltage protection (OVP) is activated, the ALM LED blinks, and the OUTPUT is turned off.

The overvoltage protection (OVP) can be set at the range between approximately 5 % to 105 % of the rated output voltage.

#### Setup procedure of the OVP trip point

**⚠ CAUTION**

- To set the OVP trip point, an overvoltage must actually be output. If a load is connected to the output terminal, remove it.

1. Using a flat-blade screwdriver, turn the O.V.P variable resistor clockwise all the way.

- 
2. Check that the OUTPUT switch is off and turn on the POWER switch.
  3. Output the voltage that you wish to specify as overvoltage.
  4. Turn the O.V.P variable resistor gradually counter-clockwise and stop turning when OVP trips (ALM LED lights).
  5. Lower the output setting and clear the alarm.

### Clearing alarms

Turn off the OUTPUT switch. Then, turn off the POWER switch and back on again. In this case, if you do not decrease the preset output voltage, OVP trips again when the OUTPUT switch is turn on.

#### 4.4.2 Overheat Protection (OHP) Function

The overheat protection (OHP) is activated when the built-in heat sink equipped with the PMC-A reaches approximately 110 °C. When tripped to the status of OHP, the ALM LED lights and the output is turned off.

#### 4.4.3 Other Protection Functions

##### ■ Temperature fuse

The temperature fuse is built into the wire-wound section of the power transformer. When this fuse is blown out, the input power is shut down and the output is turned off. It is suspected that the product may have malfunctioned, contact your Kikusui distributor or agent.

### ■ Input fuse

A fuse for AC input. If the fuse is blown out, the input power is shut down and the output is turned off. When replacing the fuse, see page 66, 6.1 Replacing the Fuse.

## 4.5 Remote Sensing

The remote sensing function is used to reduce the influence of voltage drops due to the load cable resistance and stabilize the output voltage across the load. The remote sensing function of this power supply can compensate up to approximately 0.6 V for a single line.

To perform remote sensing, an electrolytic capacitor of several-hundred  $\mu\text{F}$  is required at the sensing point (load terminal).

#### NOTE

- The remote sensing function is not available on models with rated output of 70 V or higher.
- When the remote sensing function is not performed, make sure that the setting is in off position.

### Handling of SENSING terminals

Strip the wire insulation and insert the wire into the hole while holding down part A of the terminal using a flat-blade screwdriver or other similar means. See Fig. 4-2.

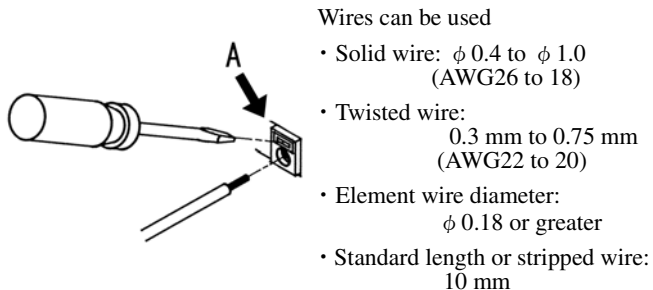

Fig. 4-2 Connection to SENSING terminals

- 
- ⚠ CAUTION**
- After inserting the wire, check that it does not come loose.
  - Be sure the exposed section of the wire does not touch the chassis or other wires such as the wire of the adjacent terminal.
- 

## Connection and setup procedure

1. Turn off the POWER switch and OUTPUT switch.
2. Connect the cables as shown in Fig. 4-3  
For the handling of the SENSING terminal, see section Fig. 4-2
3. Turn on the REMOTE SENSING switch.

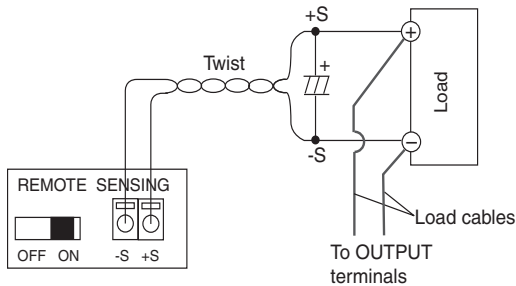

Fig. 4-3 Connection of the sensing cable

- 
- ⚠ WARNING**
- **For sensing cables, use cables with a higher voltage rating than the isolation voltage of the power supply.**

- ⚠ CAUTION**
- Burnout may occur in the load. If the sensing wires come loose, the output voltage across the load cannot be stabilized and may cause excessive voltage to be applied to the load. Securely connect the sensing wires such as by using crimp terminals.
-

## 4.6 Master-Slave Parallel Operation

Up to three slave power supplies can be connected in parallel with a master power supply to increase the current capacity. In master-slave parallel operation, the total output of the power supplies connected in parallel can be controlled using only the master power supply.

- ⚠ CAUTION** • Connecting power supplies with different rated outputs can cause a malfunction. Only PMC-A series power supplies with the same rated output voltage and rated output current can be connected in parallel.

- NOTE** • Parallel operation by simply connecting the output of each power supply is also possible. However, in this case, the output of the power supplies connected in parallel must be set the same. It is recommended that master-slave parallel operation, which allows power supplies connected in parallel to be controlled as a single power supply, be used.

### Handling of J1 Terminal

Strip the wire insulation and insert the wire into the hole while holding down part A of the terminal using a flat-blade screwdriver or other similar means. See Fig. 4-4.

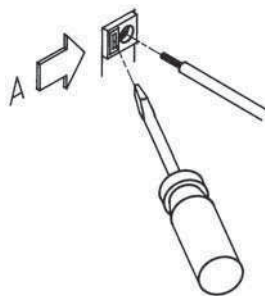

Wires can be used

- Solid wire:  $\phi$  0.4 to  $\phi$  1.0 (AWG26 to 18)
- Twisted wire: 0.3 mm to 0.75 mm (AWG22 to 20)
- Element wire diameter:  $\phi$  0.18 or greater
- Standard length or stripped wire: 10 mm

Fig. 4-4 Connection to J1 terminal

---

## 4.6.1 Functions during Master-Slave Parallel Operation

The functions of the PMC-A during master-slave parallel operation are as follows.

### ■ Voltmeter and Ammeter

For the total output current, sum the currents of the master and slave units.

### ■ Remote Sensing

Available only on the master unit.

### ■ External Control

Available only on the master unit.

### ■ External Monitoring

- External monitoring of output voltage (V MON)  
Can be monitored on the master unit.
- External monitoring of output current (I MON)  
The output current of each master and slave units can be monitored. For the total output current, sum the monitor values of the master and slave units.
- Status monitors  
The status of the constant voltage operation (CV STATUS), constant current operation (CC STATUS), output on, and POWER switch on can be monitored on each master and slave units.

---

**⚠ CAUTION** • Do not connect the common wires of the master and slave monitors outside of the PMC-A. If the wire connecting the load comes loose, the common wire will break.

---

## ■ Alarm

The alarm detected by single unit of the PMC-A can be also detected under the master-slave parallel operation.

### Connection and setup procedure

1. Turn off the OUTPUT and POWER switches on all power supplies that are to be connected in parallel.
2. Choose the power supply that will be the master.
3. Set the OVP (overvoltage protection) trip point on the master and slave power supplies.

In parallel operation, set the OVP trip point not only on the master power supply but also slave power supplies. However, set the OVP trip point of the slave power supplies slightly higher than that of the master power supply, so that the OVP function of the master power supply is activated first.

4. Connect and set up each power supply as shown in Fig. 4-5. Set the S5 switch on all slave power supplies to the down (0) position.

As for handling J1 terminal, see page 45, Fig. 4-4 Connection to J1 terminal.

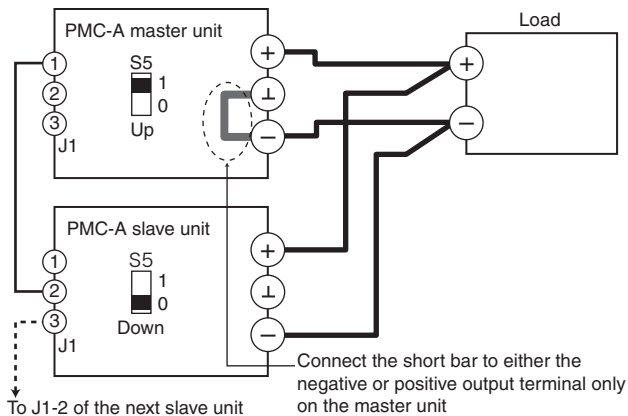

Fig. 4-5 Master-slave parallel connection and setup

---

**⚠ CAUTION**

- When performing master-slave parallel operation, be sure to follow the procedure below. Since the slave power supply is under master power supply's control, a mistake in the procedure may cause the slave power supply to output the maximum voltage.
- 

## Starting and ending parallel operation

### ■ Start procedure

1. Turn off the OUTPUT and POWER switches on all power supplies that are connected in parallel.
2. Turn on the POWER switch on the slave power supplies.
3. Turn on the POWER switch on the master power supply.
4. Turn the VOLTAGE and CURRENT knobs of the slave power supplies clockwise all the way.

If the output setting of the slave power supplies is not set to the maximum, the slave power supplies will not be able to follow up the output setting of the master power supply.

5. While holding down the LIMIT switch on the master power supply, set the output voltage and output current.

The actual output current setting is the value specified on the master power supply multiplied by the number of power supplies.

6. Turn on the OUTPUT switch on the slave power supplies.

C.C LED lights on the slave power supply panels.

7. Turn on the OUTPUT switch on the master power supply.





---

C.V LED lights on the master power supply panel.

### ■ End procedure

1. Turn off the OUTPUT switch on the master power supply.
2. Turn off the OUTPUT switch on the slave power supplies.
3. Turn off the POWER switch on the slave power supplies.
4. Turn off the POWER switch on the master power supply.

### When the Output voltage cannot be set. (Type I model only)

When the output voltage cannot be set with the master unit or a few voltages are output at 0 V setting, adjust the variable resistor for calibration in the following procedure. See page 67, Test equipment required for calibration for the test equipment required and environment. See Fig. 6-3 for the connection of the equipment.

---

 **CAUTION** • Do not set the output current greater than or equal to 105 % of the rated current for this adjustment. If you do, the power supply may malfunction.

---

### ■ Adjustment procedure

1. Set the output current to 0 A.  
When operating by the front panel (local control), turn the CURRENT knob counterclockwise all the way. When using analog remote control, set the control signal to 0 V or 0  $\Omega$ .
2. Turn on the OUTPUT switch.

- 
3. Turn the VOLTAGE knob clockwise until constant current operation is achieved.

Offset adjustment is always performed under constant current operation.

4. Adjust IOUT OFS (Variable resistor D) so that the output current (a value calculated from the external DVM reading and shunt resistance) is 0 A.
5. Turn IOUT OFS (variable resistor D) 1 to 1.5 scales (angle of approx. 30 to 40 degree) counterclockwise.
6. Set the output current to the rated output current.  
When operating by the front panel (local control), turn the CURRENT knob clockwise all the way. When using analog remote control, set the control signal to 10 V or 10 k $\Omega$ .
7. Adjust IOUT MAX (Variable resistor B) so that the output current (a value calculated from the external DVM reading and shunt resistance) is slightly higher than the rated current.

**When the rated output voltage is set, operation mode of the slave unit changes from CC to CV. (Type I model only)**

Readjust the output voltage at full scale in the following procedure. See page 67, Test equipment required for calibration for the test equipment required and environment. See Fig. 6-2 for the connection of the equipment.

---

**⚠ CAUTION** • Do not set the output voltage greater than or equal to 105 % of the rated voltage for this adjustment. If you do, the power supply may malfunction.

---

**■ Adjustment procedure**

1. Set the output voltage to the maximum output voltage.



When operating by the front panel (local control), turn the VOLTAGE knob clockwise all the way. When using analog remote control, set the control signal to 10 V or 10 k $\Omega$ .

2. Adjust the output voltage in either of two ways shown in the following.
  - Adjust Vout MAX (variable resistor A) so that the output voltage of the slave unit (DVM reading) is 50 mV higher than that of the master unit.
  - Adjust Vout MAX (variable resistor A) so that both output voltages of the master and slave units are the voltage value shown in the following or less.

PMC18-1A	18.10 V $\pm$ 0.01 V
PMC18-2A	
PMC18-3A	
PMC35-0.5A	35.20 V $\pm$ 0.01 V
PMC35-1A	
PMC35-2A	

## 4.7 Series Operation

The output of the power supplies can be connected in series to increase the output voltage.

Master-slave series operation is not possible. The total of the output voltage of each power supply is supplied to the load.



**WARNING**

- Be sure to observe the maximum number of slave power supplies that can be connected in series. If the maximum output voltage of the power supplies connected in series exceeds the isolation voltage, electric shock may occur.  
Due to this reason, series operation is not possible on the PMC350-0.2A and PMC500-0.1A.

---

## Maximum number of power supplies connected in series

The number of power supplies that can be connected in series depends on the output voltage of the model and the isolation voltage. Be sure the total output voltage of the power supplies connected in series does not exceed the isolation voltage. For the isolation voltage of each model, see the specifications.

**Example** In the case of the PMC35-3A, the isolation voltage is 250 V. Therefore, the calculation gives  $250/35 = 7.14$  which means that up to seven power supplies can be connected in series.

### 4.7.1 Functions during Series operation

The functions of the PMC-A during series operation are as follows.

#### ■ Voltmeter and Ammeter

For the total output current, sum the each units.

#### ■ Remote Sensing

Can not be used.

#### ■ External Control

Can not be used.

#### ■ External Monitoring



- **Possible electric shock while the external monitoring is performed. When monitoring the output voltage or current during series operation, the common electric potential of the monitor signal is different between each unit.**
-

- External monitoring of output voltage (V MON)  
Can be monitored on each unit.  
For the total output voltage, sum the monitor values of each units.
- External monitoring of output current (I MON)  
The output current of each unit can be monitored.
- Status monitors  
The status of the constant voltage operation (CV STATUS), constant current operation (CC STATUS), output on, and POWER switch on can be monitored on each unit.

#### ■ Alarm

The alarm detected by single unit of the PMC-A can be also detected under the series operation.

### Connection and setup procedure

1. Turn off the OUTPUT and POWER switches on all power supplies that are to be connected in series.
2. Set the OVP trip point on all power supplies.
3. Set the current that can be supplied to the load on all power supplies.
4. Connect the power supplies as shown in Fig. 4-6.

The figure shows the case when two slave power supplies are connected in series.

### Starting and ending series operation

To start series operation, turn on the POWER switch one by one in an arbitrary order with the OUTPUT switch on all power supplies turned off.

To stop series operation, turn off the OUTPUT switch on all power supplies, and then turn off the POWER switch one by one in an arbitrary order.

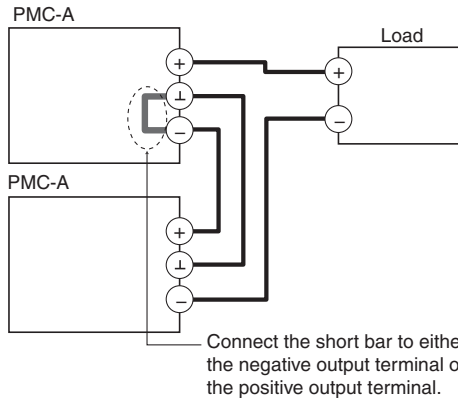

Fig. 4-6 Series Operation



# 5

## External Control

---

This chapter describes external control functions.

---

**NOTE**

For those customers using the PMC-A series with the type of 14 pins of J2 connector, please note that the PMC-A series has been updated with adding the feature of external control of which existing the 14-pins connector is replaced by the 26-pins connector.

In case the external control function is used by the 14-pins connector, connect the J2 connector (26-pins) to match the polarity slot against the polarity guide of the 14-pins plug, then the external control function can be used same as previous condition. As for the pin assignment of the 14-pins and the 26-pins, see page 58, Table 5-3 "Pin arrangement of the J2 connector". Furthermore, if the OMRON's 14-pins plug is used, attach the lock lever, as an standard accessory, to the 14-pins plug for detaching prevention.

As for the polarity slot and the polarity guide, see page 57, Fig. 5-2 "J2 connector and plug assembly"

---

### 5.1 External Remote Control

The J2 connector on the rear panel can be used to control the power supply in the following manner.

Table 5-1 Available controls

Output voltage control using an external voltage (CV-V)
Output current control using an external voltage (CC-V)
Output voltage control using an external resistor (CV-R)
Output current control using an external resistor (CC-R)
Control the output ON/OFF using an external contact

**NOTE**

- Different control modes can be used simultaneously. However, simultaneous use of CV-V and CV-R or CC-V and CC-R is not possible.

### Readjustment for remote/local switching

The power supply is adjusted at the time of factory shipment assuming a front panel operation (local control). When using remote control (excluding output on/off using an external contact), the power supply must be readjusted. Readjustment is also necessary when switching back from remote control to local control. For the adjustment procedure, see 6.2 Calibration.

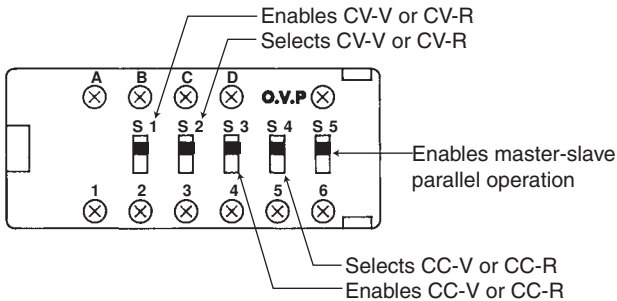

By factory default, all switches are set to the up position (1)

Fig. 5-1 Control switch

### J2 connector

For the connection of the J2 connector, insert the contact that comes with the socket that is attached to the J2 connector when you receive the power supply from the factory.

Table 5-2 lists the tools and parts (made by Omron) needed to assemble the J2 connector socket. For details, on how to use the tools, read the catalogue and other information provided by Omron.



Table 5-2 Tools and parts needed for assembly

Name	Model
Socket	XG5M-2632-N (accessory) Recommended wire size: AWG24 (UL-1061)
Contact	XG5W-0031 (accessory) Recommended wire size: AWG24 (UL-1061)
Single contact connection tool	XY2B-7006
Contact removal tool	XY2E-0001
Semi-cover	XG5S-1301 (2 pieces used)

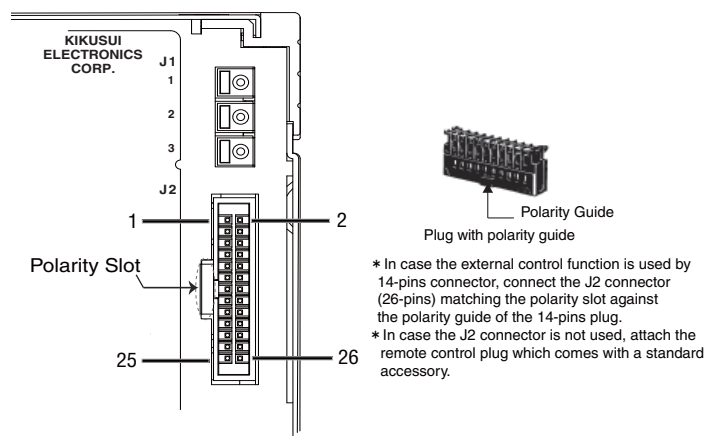

Fig. 5-2 J2 connector and plug assembly

Table 5-3 Pin arrangement of the J2 connector

14 pins type *2	Pin No.	Signal Name	Description
-	1	CV STATUS	On during CV operation (open collector output by a photocoupler)*1
-	2	CC STATUS	On during CC operation (open collector output by a photocoupler)*1
-	3	V MON	Output voltage monitor (Outputs 0 % to 100 % of the rated current using 0 V to 10 V)
-	4	I MON	Output current monitor (Outputs 0 % to 100 % of the rated current using 0 V to 10 V)
-	5	N.C.	No connection
-	6	N.C.	No connection
1	7	EXT-V CV CONT	External voltage control of output voltage. (0 % to 100 % of the rated output voltage using 0 V to 10 V).
2	8	EXT-R CV CONT COM	Common for external resistance control of output voltage.
3	9	A COM	Common for external signal of pins 3, 4, 7, 15. Connected to the negative electrode (-S) of the sensing input when remote sensing is used. Connected to -(neg.) output when remote sensing is not used.
4	10	EXT-R CV CONT	External resistance control of output voltage. (0 % to 100 % of the rated output voltage using 0 V to 10 V).
5	11	EXT-R CC CONT	External resistance control of output current. (0 % to 100 % of the rated output current using 0 $\Omega$ to 10 k $\Omega$ ).
6	12	A COM	Same as pin 9.
7	13	EXT-R CC CONT COM	Common for external resistance control of output current.
8	14	A COM	Same as pin 9.
9	15	EXT-V CC CONT	External voltage control of output current. (0 % to 100 % of the rated output current 0 V to 10 V).
10	16	NO CONNECTION	No connection
11	17	A COM	Same as pin 9.

14 pins type *2	Pin No.	Signal Name	Description
12	18	D COM	Common for external signal of pins 19. Connected to the negative electrode (-S) of the sensing input when remote sensing is used. Connected to -(neg.) output when remote sensing is not used.
13	19	OUT ON/OFF CONT	Output on/off control. Output off by external contact input.
14	20	D COM	Same as pin 18.
-	21	N.C.	No connection
-	22	N.C.	No connection
-	23	ALM STATUS	Turns on when the OVP, OHP is activated. (open collector output by a photocoupler)*1
-	24	OUT ON STATUS	Turns on when the output is on. (open collector output by a photocoupler)*1
-	25	PWR ON STATUS	Turns on when the power switch is on. (open collector output by a photocoupler)*1
-	26	STATUS COM	Common for status signal of pins 1, 2, 23, 24, and 25.

\*1 Open collector output (maximum voltage 30 V, maximum current approx. 5 mA) Insulated from the control circuits.

\*2 Indicates the pin assignment of the 14-pins plug.

## 5.1.1 Remote Control Connection and Setup



**WARNING**

- **Possible electric shock. Turn off the POWER switch when wiring the J2 connector.**
- **Possible electric shock and damage to the connected equipment caused by the ESD (Electro-Static Discharge). Attach the remote control plug when J2 connector is not used, the remote control plug comes with a standard accessory.**
- **Possible electric shock and damage to internal circuit. The common terminal of the J2 connector as well as resistors, voltage sources, and switches connected to the J2 connector are at approximately the same potential as the negative output terminal. Protect them using insulation material**

**having a withstanding voltage that is greater than the isolation voltage of the power supply.**

1. Turn off the OUTPUT and POWER switches.
2. Select the control mode from Table 5-1.  
Combinations are also possible, but simultaneous use of CV-R and CV-V or CC-R and CC-V is not possible.
3. Refer to the setup and connection procedure for the appropriate control mode given in the subsequent control sections and set the control switch and connect the control source.
4. Check the J2 connector connection and switch settings.
5. After performing the setup above, readjustment is necessary. For the adjustment procedure, see section 6.2 Calibration.

**Controlling the output voltage using external voltage**

This mode is used to control the output voltage using an external voltage in the range of 0 V to approximately 10 V.

- The input impedance between J2-7 and J2-9 is approximately 10 kΩ.
- Use a low-noise and highly stable source for Ein.

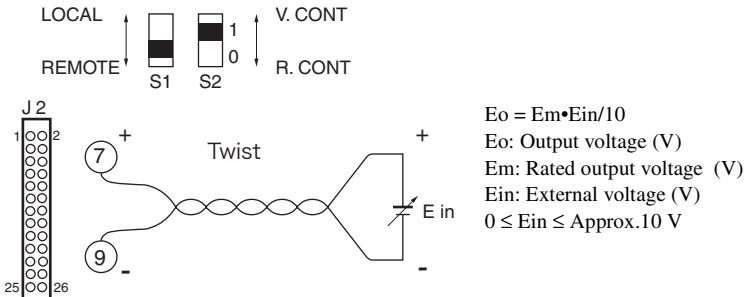

Fig. 5-3 CV-V setup and connection

## Controlling the output voltage using external resistance

This mode is used to control the output voltage using an external resistor in the range of  $0\ \Omega$  to approx.  $10\ \text{k}\Omega$ .

**⚠ CAUTION** • If external resistor  $R_{in}$  comes loose, a voltage above the rated output will be delivered. Be sure that the connection is secure.

- A current of approximately 1 mA flows through  $R_{in}$  at all times.
- For  $R_{in}$ , use a highly stable resistor with good temperature coefficient and small aging effect such a 1/2 W or larger metal film or wire-wound type resistor.

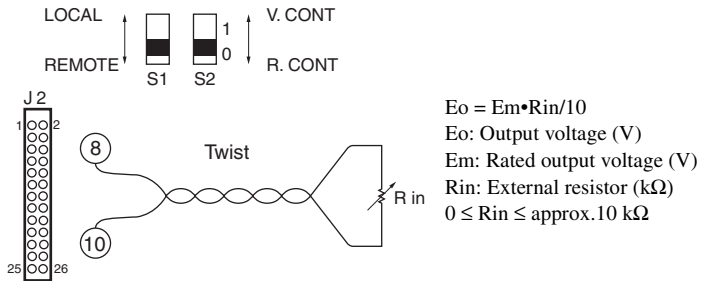

Fig. 5-4 CV-R setup and connection

## Controlling the output current using external voltage

This mode is used to control the output current using an external voltage in the range of 0 V to approximately 10 V.

- The input impedance between J2-15 and J2-17 is approximately  $10\ \text{k}\Omega$ .
- Use a low-noise and highly stable source for  $E_{in}$ .

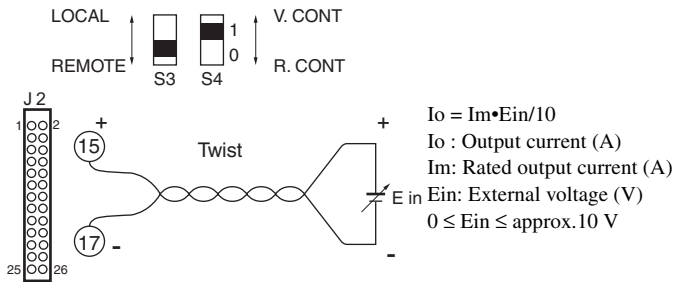

Fig. 5-5 CC-V setup and connection

## Controlling the output current using external resistance

This mode is used to control the output current using an external resistor in the range of  $0 \Omega$  to approx.  $10 \text{ k}\Omega$ .

**CAUTION** • If external resistor  $R_{in}$  comes loose, a current above the rated output will be delivered. Be sure that the connection is secure.

- A current of approximately 1 mA flows through  $R_{in}$  at all times.
- For  $R_{in}$ , use a highly stable resistor with good temperature coefficient and small aging effect such a 1/2 W or larger metal film or wire-wound type resistor.

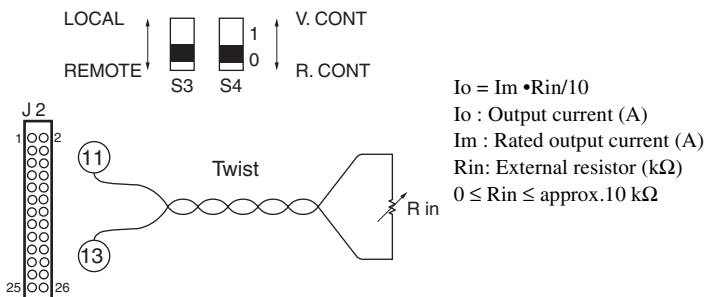

Fig. 5-6 CC-R setup and connection

## Output on/off control

The output on/off can be controlled using an external contact. When the external contact is closed the output turns off.

- J2-19 is pulled up internally to + 5 V or + 15 V using 10 k $\Omega$  resistor. (Type I is + 15 V, Type II is + 5 V)
- J2-20 is approximately at the same electrical potential as the negative output terminal.
- Off has precedence in the output on/off operation. Therefore, if the OUTPUT switch on the front panel is not turned on, the output cannot be turned on/off using the external contact.
- If you press the LIMIT switch when the OUTPUT switch is on and the external contact is closed (output off condition), a correct output setting will not be displayed. Turn off the OUTPUT switch first and then press the LIMIT switch.

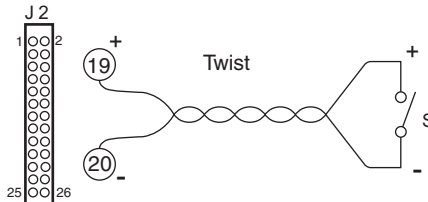

Fig. 5-7 Output on/off control connection

## 5.2 Remote Monitoring

### 5.2.1 External Monitoring of the Output Voltage and Output Current.

The J2 connector consists of monitor outputs for output voltage and output current.

Table 5-4 Monitor output of output voltage and output current

Pin No.	Signal name	Description
9, 12, 14, 17	A COM	Common for remote control input, Common for output monitor
3	V MON	Monitor output of output voltage 0 to approx. 10 V for 0 to the rated output voltage
4	I MON	Monitor output of output current 0 to approx. 10 V for 0 to the rated output current

**CAUTION** • Shorting V MON and I MON to A COM can cause damage to the PMC-A.

**NOTE**

- Monitor output rating  
Output impedance : 1 k $\Omega$  or less  
Maximum output current : Approx. 10 mA
- The monitor outputs are used to monitor the DC voltage (mean value). They cannot be used to accurately monitor the AC components (ripple, transient response, etc.) of the actual output voltage or current.

## 5.2.2 External monitoring of the operating status

The J2 connector consists of status outputs that is used to externally monitor the operating status of the PMC-A. The following five status outputs are available.

The outputs are open collector outputs of photocouplers; they are insulated from the internal circuits of the PMC-A.



Table 5-5 Status output

Pin No.	Signal name	Description	Circuit
26	STATUS COM	Common for status output. Photocoupler emitter output.	
1	CV STATUS	Set to ON status when in constant voltage mode. Photocoupler collector output.	
2	CC STATUS	Set to ON status when in constant current mode. Photocoupler collector output.	
23	ALM STATUS	Set to ON status when in protection function is activated. Photocoupler collector output.	
24	OUTON STATUS	Set to ON status when the OUTPUT is turned on. Photocoupler collector output.	
25	PWRON STATUS	Set to ON status when the POWER is turned on. Photocoupler collector output.	

**NOTE**

- Maximum rating of each signal terminal  
Maximum applied voltage (for each 1 pin) : 30 V,  
Maximum current (sink) approx. 5 mA.



# 6

## Maintenance

This chapter describes replacing the fuse and calibration procedure.

### 6.1 Replacing the Fuse

#### **WARNING**

- To prevent the possibility of electric shock, turn off the **POWER** switch on the power supply and unplug the power cord plug before replacing the fuse.
- Use a fuse of shape, rating, and characteristics that conform to the power supply.
- Using a fuse of a different rating or shorting the fuse holder is dangerous. Never carry out such acts

1. Turn off the **POWER** switch and unplug the power cord.
2. Remove the power cord from the **INPUT** connector on the rear panel.
3. Remove the fuse holder using a tool such as a flat-blade screwdriver as shown in Fig. 6-1.

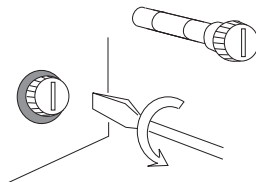

Fuse rating varies depending on the model. For details, see Chapter 7 "Specifications".

Fig. 6-1 Removing the fuse holder

## 6.2 Calibration

The power supply is calibrated at the factory before shipment. However, periodic calibration is necessary due to changes that occur after extended use.

For calibration, contact your Kikusui agent or distributor. If you wish to calibrate the power supply, follow the procedure below. However, this calibration procedure omits some of the calibration items.

### Test equipment required for calibration

For calibration, the following equipment is necessary.

- DC voltmeter (DVM) with measuring accuracy of 0.02 % or better.
- Shunt resistor with accuracy of 0.1 % or better (a resistor capable of handling the rated output current of the PMC-A series power supply being calibrated).

### Environment

Perform calibration under the following environment.

- Ambient temperature:  $23\text{ }^{\circ}\text{C} \pm 5\text{ }^{\circ}\text{C}$
- Ambient humidity: 80 % rh or less

To minimize the calibration error due to initial drift, warm up (turn on) the power supply for at least 30 minutes before calibration. In addition, warm up the DVM and shunt resistor for their appropriate time.

### Calibration Procedure

Calibration items can be grouped into two types: voltage system and current system. Calibration is performed using the variable resistors inside the front panel sub-panel cover.

**NOTE**

- Never touch variable resistor 6, because it is not to be adjusted by the user. If you turn this variable resistor by mistake, recalibration will be necessary. Please contact your Kikusui agent or distributor.
- The functionality of the variable resistors is different between Type I and Type II

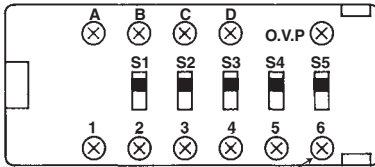

Do not touch this variable resistor

	Type I	Type II
A	Vout MAX	Vout MAX
B	Iout MAX	Iout MAX
C	Vout OFS	Not used
D	Iout OFS	Not used
1	V METER FS	Not used
2	I METER FS	V METER FS
3	I METER OFS	Vout OFS
4	V LIMIT FS	V LIMIT FS
5	I LIMIT FS	I METER FS
6	Undisclosed	Undisclosed

Table 6-1 Variable resistors

### Voltage system calibration procedure

The following four items are available in the voltage system. Since the items are related, be sure to calibrate all items according to the following procedure.

- Output voltage offset
- Output voltage at full scale
- Voltmeter at full scale
- Preset voltage indicator at full scale

#### ■ Connecting the equipment

1. Turn off the OUTPUT and POWER switches.
2. Connect the cables as shown in Fig. 6-2.

---

Connect the negative terminal and the chassis ground terminal using a short bar.

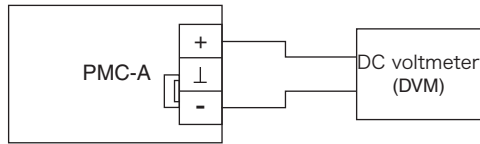

Fig. 6-2 Connection for voltage system calibration

3. Turn on the POWER switch.

#### ■ Output voltage offset

4. Set the output voltage to 0 V.

When using local control, turn the VOLTAGE knob counterclockwise all the way. When using analog remote control, set the control signal to 0 V or 0  $\Omega$ .

5. Turn on the OUTPUT switch.
6. Turn the CURRENT knob clockwise until constant voltage operation is achieved.

Offset adjustment is always performed under constant voltage operation

7. Adjust Vout OFS so that the output voltage (DVM reading) is 0 V.

Type I: Variable resistor C

Type II: Variable resistor 3

#### ■ Output voltage at full scale

---

**⚠ CAUTION**

- Do not set the output voltage greater than or equal to 105 % of the rated voltage for this adjustment. If you do, the power supply may malfunction.
- 



---

**NOTE**

If the output voltage is being controlled using an external voltage (CV-V mode) on Type II models, the output voltage at full scale cannot be adjusted using the variable resistor. Adjust the external voltage to obtain the full scale voltage.

---

8. Set the output voltage to the maximum output voltage.

When using local control, turn the VOLTAGE knob clockwise all the way. When using analog remote control, set the control signal to 10 V or 10 k $\Omega$ .

9. Adjust Vout MAX so that the output voltage (DVM reading) is slightly higher than the rated voltage.

Both Type I and Type II: Variable resistor A

#### ■ Voltmeter at full scale

10. Set the output voltage (DVM reading) to the rated voltage.

11. Adjust V METER FS so that the voltmeter reading on the power supply is equal to the DVM reading.

Type I: Variable resistor 1

Type II: Variable resistor 2

#### ■ Preset voltage indicator at full scale

12. Adjust V LIMIT FS so that the voltmeter reading on the power supply is equal to the external DVM reading when the LIMIT switch is pressed while delivering rated voltage.

Both Type I and Type II: Variable resistor 4



## Current system calibration procedure

The following five items (two items on Type II models) are available in the current system. Since the items are related, be sure to calibrate all items according to the following procedure.

- Output current offset (Type I model only)
- Ammeter offset (Type I model only)
- Output current at full scale
- Ammeter at full scale
- Preset current indicator at full scale (Type I model only)

### ■ Connecting the equipment

1. Turn off the OUTPUT and POWER switches.
2. Connect the cables as shown in Fig. 6-3.

Connect the negative terminal and the chassis ground terminal using a short bar.

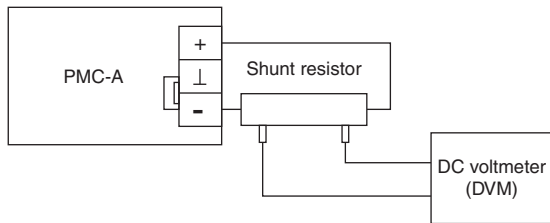

Fig. 6-3 Connection for current system calibration

3. Turn on the POWER switch.

### ■ Output current offset (Type I model only)

4. Set the output current to 0 A.

When using local control, turn the CURRENT knob counterclockwise all the way. When using analog remote control, set the control signal to 0 V or 0  $\Omega$ .

5. Turn on the OUTPUT switch.

- 
6. Turn the VOLTAGE knob clockwise until constant current operation is achieved.

Offset adjustment is always performed under constant current operation.

7. Adjust IOUT OFS so that the output current (a value calculated from the external DVM reading and shunt resistance) is 0 A.

Type I: Variable resistor D

#### ■ Ammeter offset (Type I model only)

8. Adjust I METER OFS so that the ammeter reading on the power supply indicates 0.

Type I: Variable resistor 3

#### ■ Output current at full scale

---

#### CAUTION

- Do not set the output current greater than or equal to 105 % of the rated current for this adjustment. If you do, the power supply may malfunction.

---

#### NOTE

- If the output current is being controlled using an external voltage (CC-V mode) on Type II models, the output current at full scale cannot be adjusted using the variable resistor. Adjust the external voltage to obtain the full scale current.

- 
9. Set the output current to the rated output current.

When using local control, turn the CURRENT knob clockwise all the way. When using analog remote control, set the control signal to 10 V or 10 k $\Omega$ .

10. Adjust IOUT MAX so that the output current (a value calculated from the external DVM reading and shunt resistance) is slightly higher than the rated current.

Both Type I and Type II: Variable resistor B





### ■ Ammeter at full scale

11. Set the output current (a value calculated from the external DVM reading and shunt resistance) to the rated current.
12. Adjust I METER FS so that the ammeter reading on the power supply is equal to the rated current.  
Type I: Variable resistor 2  
Type II: Variable resistor 5

### ■ Preset current indicator at full scale (Type I model only)

13. Adjust I LIMIT FS so that the ammeter reading on the power supply is equal to the value calculated from the external DVM reading and shunt resistance when the LIMIT switch is pressed while delivering rated current.  
Type I: Variable resistor 5



# Specifications

---

This chapter gives description on the electrical and mechanical specifications of the PMC-A.

Unless otherwise specified, the specifications are based on the following conditions.

- The load is a pure resistance.
- The negative output is connected to the chassis terminal using the short bar provided.
- After a warm-up time of 30 minutes has elapsed with the load current flowing at  $23\text{ }^{\circ}\text{C} \pm 5\text{ }^{\circ}\text{C}$  and 80 % rh or less.
- TYP values, standard values, and calculated values do not guarantee the performance. Use these values as a guideline when using the power supply.



## 7.1 Specifications (Type I)

Type I	PMC 18-1A	PMC 18-2A	PMC 18-3A	PMC 35-0.5A	PMC 35-1A	PMC 35-2A
<b>Input specifications</b>						
Input power		100 VAC $\pm$ 10 %, 50/60 Hz, single phase (117 V, 200 V, 217 V, and 234 V are factory options)				
Power consumption*1 (Max)		Approx. 50 VA (65 VA)	Approx. 100 VA (130 VA)	Approx. 160 VA (230 VA)	Approx. 50 VA (65 VA)	Approx. 95 VA (130 VA)
Inrush current	Peak current	20 A to 30 A				
	Half value width	5 ms				
<b>Output specifications</b>						
<b>Voltage</b>						
Rated voltage		18 V			35 V	
Variable range		0 V to 18 V			0 V to 35 V	
<b>Constant voltage characteristics</b>						
Resolution (Calculated value)*2		3.3 mV			6.3 mV	
Preset knob turns		10 turns				
Source effect *3		1 mV			3 mV	
Load effect *4		2 mV	4 mV	3 mV		
Transient response (standard value) *5		50 $\mu$ s				
Ripple noise (RMS)*6		500 $\mu$ V				
Full-load rise time (TYP) *7		70 ms			40 ms	
No-load fall time (TYP) *8		600 ms			650 ms	1300 ms
Temperature coefficient		100 ppm/ $^{\circ}$ C (TYP)				

Type I	PMC 18-1A	PMC 18-2A	PMC 18-3A	PMC 35-0.5A	PMC 35-1A	PMC 35-2A
<b>Output specifications</b>						
<b>Current</b>						
Rated current	1 A	2 A	3 A	0.5 A	1 A	2 A
Variable range	0 A to 1 A	0 A to 2 A	0 A to 3 A	0 A to 0.5 A	0 A to 1 A	0 A to 2 A
<b>Constant current characteristics</b>						
Resolution (Calculated value)*2	180 $\mu$ A	360 $\mu$ A	540 $\mu$ A	90 $\mu$ A	180 $\mu$ A	360 $\mu$ A
Preset knob turns	10 turns					
Source effect *3	10 mA					
Load effect *4	5 mA					
Ripple noise (RMS) *6	1 mA					
Temperature coefficient	200 ppm/ °C (TYP)					
<b>Display function</b>						
<b>Operation display</b>						
C.V operation	C.V LED (green) lights					
C.C operation	C.C LED (red) lights					
<b>Voltage display (fixed range)</b>						
Maximum display	19.99			199.9		
Display error	$\pm$ (0.5 % of rdg + 2 digits)					
Temperature coefficient	300 ppm/ °C (TYP)					
<b>Current display (fixed range)</b>						
Maximum display	9.99		0.999		9.99	
Display error	$\pm$ (1 % of rdg + 5 digits)					
Temperature coefficient	400 ppm/ °C (TYP)					

Type I		PMC 18-1A	PMC 18-2A	PMC 18-3A	PMC 35-0.5A	PMC 35-1A	PMC 35-2A	
<b>Protection function</b>								
Overvoltage protection (OVP)		Reset by turning off the POWER switch ALM LED (red) lights when tripped Preset range: Approx. 5 % to 105 % of the rated output voltage						
Overheat protection (OHP)		Reset by turning off the POWER switch ALM LED (red) lights when tripped OUTPUT turns off when the temperature reaches approx. 110 °C at the built-in heat sink.						
Temperature fuse		Built into the wire-wound section of the 130 °C power transformer						
Input fuse	For 100 V system	2 A (S.B) [99-02-0153]	3 A (S.B) [99-02-0154]	4 A (S.B) [99-02-0155]	2 A (S.B) [99-02-0153]	3 A (S.B) [99-02-0154]	4 A (S.B) [99-02-0155]	
	For 200 V system	1.5 A(S.B) [99-02-0152]		2 A(S.B) [99-02-0153]	1.5 A(S.B) [99-02-0152]		2 A(S.B) [99-02-0153]	
<b>Remote monitoring function</b>								
Monitor signal output *9								
V MON (voltage)								
		at rated voltage output						10.0 V ± 0.5 V
		at 0 V output						0.0 V ± 0.5 V
I MON (current)								
		at rated current output						10.0 V ± 0.5 V
		at 0 V output						0.0 V ± 0.5 V
Status signal output *9 , *10								
		OUTON STATUS						Turns on when the OUTPUT is on.
		CV STATUS						On during CV operation
		CC STATUS						On during CC operation
		ALM STATUS						Turns on when the OVP, OHP is activated.
		PWRON STATUS						Turns on when the POWER is on.
<b>Remote sensing function</b>								
Remote sensing		Compensate up to 0.6 V for a single line.						

Type I	PMC 18-1A	PMC 18-2A	PMC 18-3A	PMC 35-0.5A	PMC 35-1A	PMC 35-2A
<b>Remote control function *9</b>						
Output voltage/control voltage ratio	18 V/ Approx. 10 V			35 V/ Approx. 10 V		
Output voltage/control resistance ratio	18 V/ Approx. 10 kΩ			35 V/ Approx. 10 kΩ		
Output current/control voltage ratio	1 A/ Approx. 10 V	2 A/ Approx. 10 V	3 A/ Approx. 10 V	0.5 A/ Approx. 10 V	1 A/ Approx. 10 V	2 A/ Approx. 10 V
Output current/control resistance ratio	1 A/ Approx. 10 kΩ	2 A/ Approx. 10 kΩ	3 A/ Approx. 10 kΩ	0.5 A/ Approx. 10 kΩ	1 A/ Approx. 10 kΩ	2 A/ Approx. 10 kΩ
<b>Master-slave parallel operation</b>						
Maximum number of connecting units	Up to four power supplies of the same model.					
<b>General</b>						
<b>Environment specifications</b>						
Operation temperature	0 °C to 40 °F (0 °F to 40 °F)					
Operation humidity	10 % rh to 80 % rh (no condensation)					
Storage temperature	-10 °C to 60 °C (14 °F to 140 °F)					
Storage humidity	Less than or equal to 90 % rh (no condensation)					
Cooling system	Unforced air cooling					
Grounding polarity	Possible for either Positive grounding or Negative grounding					
<b>Insulation resistance</b>						
Between chassis and input terminals	500 VDC, 30 MΩ or more (measured at an ambient temperature of 70 % rh or less)					
Between chassis and output terminals	500 VDC, 20 MΩ or more (measured at an ambient temperature of 70 % rh or less)					
<b>Withstand voltage</b>						
Between input and output terminals	No abnormalities at 1500 VAC for 1 minute.					
Between input terminals and chassis						
Isolation voltage	± 250 V					

Type I	PMC 18-1A	PMC 18-2A	PMC 18-3A	PMC 35-0.5A	PMC 35-1A	PMC 35-2A
<b>General</b>						
Weight	Approx. 3.5 kg (7.72 lb)	Approx. 4.0 kg (8.82 lb)	Approx. 5.0 kg (11.02 lb)	Approx. 3.5 kg (7.72 lb)	Approx. 4.0 kg (8.82 lb)	Approx. 5.0 kg (11.02 lb)
Dimensions	See Fig. 7-1					
<b>Accessories</b>						
Operation manual	1 pc.					
Power cord	1 pc.					
Analog remote control contact	20 pcs.					
Analog remote control plug	1 pc. (attached to the J2 connector on the rear panel)					
Lock lever	1 pc. (attached to the analog remote control plug)					
Fuse *11	1 pc.					

- \*1 At 100VAC rated load.
- \*2 A value calculated from the number of windings of the variable resistor. In the actual case, take 3 times to 5 times this value as a guide line.
- \*3 With respect to  $\pm 10\%$  of the line voltage.
- \*4 With respect to 0 % to 100 % of the output current.
- \*5 The time it takes for the output voltage to recover within 0.05 % + 10 mV of the rating when the output current fluctuates in the 10 % to 100 % range.
- \*6 At a measurement frequency bandwidth of 5 Hz to 1 MHz.
- \*7 The time it takes for the output voltage to rise from 10 % to 90 % of the rating when the output is turned on.
- \*8 The time it takes for the output voltage to fall from 90 % to 10 % of the rating when the output is turned off.
- \*9 J2 connector on the rear panel.
- \*10 Photocoupler open collector output. Maximum voltage 30 V, maximum current (sink) approx. 5 mA. Insulated from the output and control circuits. Status signals are not mutually insulated.
- \*11 See the rating of the fuse in the specification of "Protection function".

## 7.2 Specifications (Type II)

Type II	PMC 18-5A	PMC 35-3A	PMC 70-1A	PMC 110-0.6A	PMC 160-0.4A	PMC 250-0.25A	PMC 350-0.2A	PMC 500-0.1A	
Input specifications									
Input power		100 VAC $\pm$ 10 %, 50/60 Hz, single phase (117 V, 200 V, 217 V, and 234 V are factory option)							
Power consumption *1 (Max)		Aprx. 230 VA (280 VA)	Aprx. 240 VA (280 VA)	Approx. 150 VA (190 VA)				Aprx. 110 VA (140 VA)	
Inrush current	Peak current	70 A to 80 A		30 A to 50 A					
	Half value width	5 ms							
Output specifications									
Voltage									
Rated voltage		18V	35V	70V	110V	160V	250V	350V	500V
Variable range		0 V to 18 V	0 V to 35 V	0 V to 70 V	0 V to 110 V	0 V to 160 V	0 V to 250 V	0 V to 350 V	0 V to 500 V
Constant voltage characteristics									
Resolution (Calculated value) *2		3.3 mV	6.3 mV	12.6 mV	19.8 mV	28.8 mV	45.0 mV	63.0 mV	90.0 mV
Preset knob turns		10 turns							
Source effect *3		1 mV	3 mV	5 mV	7 mV	10 mV	15 mV	25 mV	30 mV
Load effect *4		5 mV	4 mV	5 mV	7 mV	10 mV	15 mV	25 mV	30 mV
Transient response (standard value) *5		50 $\mu$ s		100 $\mu$ s					
Ripple noise (RMS) *6		500 $\mu$ V		1 mV	2 mV	3 mV		5 mV	10 mV
Full-load rise time (TYP) *7		80 ms	450 ms	60 ms	50 ms	150 ms	100 ms	140 ms	190 ms
No-load fall time (TYP) *8		330 ms	380 ms	260 ms	270 ms	220 ms	100 ms	90 ms	90 ms
Temperature coefficient		100 ppm/ °C (TYP)							



Type II	PMC 18-5A	PMC 35-3A	PMC 70-1A	PMC 110-0.6A	PMC 160-0.4A	PMC 250-0.25A	PMC 350-0.2A	PMC 500-0.1A
<b>Output specifications</b>								
<b>Current</b>								
Rated current	5 A	3 A	1 A	0.6 A	0.4 A	0.25 A	0.2 A	0.1 A
Variable range	0A to 5 A	0 A to 3 A	0A to 1 A	0 A to 0.6 A	0 A to 0.4 A	0 A to 0.25 A	0 A to 0.2 A	0 A to 0.1 A
<b>Constant current characteristics</b>								
Resolution (Calculated) *2	0.9 mA	0.54 mA	180 $\mu$ A	108 $\mu$ A	72 $\mu$ A	45 $\mu$ A	36 $\mu$ A	18 $\mu$ A
Preset knob turns	10 turns							
Source effect *3	5 mA		2 mA			1 mA		
Load effect *4	10 mA			5 mA				3 mA
Ripple noise (RMS) *6	2 mA	1 mA						
Temperature coefficient	200 ppm/ °C (TYP)							
<b>Display function</b>								
<b>Operation display</b>								
C.V operation	C.V LED (green) lights							
C.C operation	C.C LED (red) lights							
<b>Voltage display (fixed range)</b>								
Max. display	19.99	199.9				999		
Display error	$\pm$ (0.5 % of rdg + 2 digits)							
Temperature coefficient	300 ppm/ °C (TYP)							
<b>Current display (fixed range)</b>								
Max. display	9.99			0.999				
Display error	$\pm$ (1 % of rdg + 5 digits)							
Temperature coefficient	400 ppm/ °C (TYP)							

Type II	PMC 18-5A	PMC 35-3A	PMC 70-1A	PMC 110- 0.6A	PMC 160- 0.4A	PMC 250- 0.25A	PMC 350- 0.2A	PMC 500- 0.1A
<b>Protection function</b>								
Overvoltage protection (OVP)		Reset by turning off the POWER switch ALM LED (red) lights when tripped Preset range: Approx. 5 % to 105 % of the rated output voltage						
Overheat protection (OHP)		Reset by turning off the POWER switch ALM LED (red) lights when tripped OUTPUT turns off when the temperature reaches approx. 110 °C at the built-in heat sink.						
Temperature fuse		Built into the wire-wound section of the 130 °C power transformer						
Input fuse	For 100 V system	4 A (S.B) [99-02-0155]						
	For 200 V system	2 A (S.B) [99-02-0153]						
<b>Remote monitoring function</b>								
Monitor signal output *9								
V MON (voltage)								
at rated voltage output		10.0 V ± 0.5 V						
at 0 V output		0.0 V ± 0.5 V						
Monitor signal output *9								
I MON (current)								
at rated voltage output		10.0 V ± 0.5 V						
at 0 V output		0.0 V ± 0.5 V						
Status signal output *9 , *10								
OUTON STATUS		Turns on when the OUTPUT is on.						
CV STATUS		On during CV operation						
CC STATUS		On during CC operation						
ALM STATUS		Turns on when the OVP, OHP is activated.						
PWRON STATUS		Turns on when the POWER is on.						
<b>Remote sensing function</b>								
Remote sensing		Compensate up to 0.6 V for a single line.		Not Available				

Type II	PMC 18-5A	PMC 35-3A	PMC 70-1A	PMC 110- 0.6A	PMC 160- 0.4A	PMC 250- 0.25A	PMC 350- 0.2A	PMC 500- 0.1A
Remote control function *9								
Output voltage/control voltage ratio	18 V/ Aprx. 10 V	35 V/ Aprx. 10 V	70 V/ Aprx. 10 V	110 V/ Aprx. 10 V	160 V/ Aprx. 10 V	250 V/ Aprx. 10 V	350 V/ Aprx. 10 V	500 V/ Aprx. 10 V
Output voltage/control resistance ratio	18 V/ Aprx. 10 k $\Omega$	35 V/ Aprx. 10 k $\Omega$	70 V/ Aprx. 10 k $\Omega$	110 V/ Aprx. 10 k $\Omega$	160 V/ Aprx. 10 k $\Omega$	250 V/ Aprx. 10 k $\Omega$	350 V/ Aprx. 10 k $\Omega$	500 V/ Aprx. 10 k $\Omega$
Output current/control voltage ratio	5 A/ Aprx. 10 V	3 A/ Aprx. 10 V	1 A/ Aprx. 10 V	0.6 A/ Aprx. 10 V	0.4 A/ Aprx. 10 V	0.25 A/ Aprx. 10 V	0.2 A/ Aprx. 10 V	0.1 A/ Aprx. 10 V
Output current/control resistance ratio	5 A/ Aprx. 10 k $\Omega$	3 A/ Aprx. 10 k $\Omega$	1 A/ Aprx. 10 k $\Omega$	0.6 A/ Aprx. 10 k $\Omega$	0.4 A/ Aprx. 10 k $\Omega$	0.25 A/ Aprx. 10 k $\Omega$	0.2 A/ Aprx. 10 k $\Omega$	0.1 A/ Aprx. 10 k $\Omega$
Master-slave parallel operation								
Maximum number of connecting units	Up to four power supplies of the same model.							
General								
Environment specifications								
Operation temperature	0 °C to 40 °C (32 °F to 104 °F)							
Operation humidity	10 % rh to 80 % rh (no condensation)							
Storage temperature	-10 °C to 60 °C (14 °C to 140 °C)							
Storage humidity	Less than or equal to 90 % rh (no condensation)							
Cooling system	Unforced air cooling							
Grounding polarity	possible for either Positive grounding or Negative grounding							
Insulation resistance								
Between chassis and input terminals	500 VDC, 30 M $\Omega$ or more (measured at an ambient temperature of 70 % rh or less)							
Between chassis and output terminals	500 VDC, 20 M $\Omega$ or more (measured at an ambient temperature of 70 % rh or less)							
Withstand voltage								
Between input and output terminals	No abnormalities at 1500 VAC for 1 minute.							
Between input terminals and chassis								

Type II	PMC 18-5A	PMC 35-3A	PMC 70-1A	PMC 110- 0.6A	PMC 160- 0.4A	PMC 250- 0.25A	PMC 350- 0.2A	PMC 500- 0.1A
<b>General</b>								
Isolation voltage	$\pm 250$ V		$\pm 500$ V					
Weight	Approx. 6.0 kg (13.23 lb)		Approx. 5.5 kg (12.13 lb)				Approx 5.0 kg (11.02 lb)	
Dimensions	See Fig. 7-2							
<b>Accessories</b>								
Operation manual	1 pc.							
Power cord	1 pc.							
Analog remote control contact	20 pcs.							
Analog remote control plug	1 pc. (attached to the J2 connector on the rear panel)							
Lock lever	1 pc. (attached to the analog remote control plug)							
Fuse *11	1 pc.							

\*1 At 100VAC rated load.

\*2 A value calculated from the number of windings of the variable resistor. In the actual case, take 3 times to 5 times this value as a guide line.

\*3 With respect to  $\pm 10$  % of the line voltage.

\*4 With respect to 0 % to 100 % of the output current.

\*5 The time it takes for the output voltage to recover within 0.05 % + 10 mV of the rating when the output current fluctuates in the 10 % to 100 % range.

\*6 At a measurement frequency bandwidth of 5 Hz to 1 MHz.

\*7 The time it takes for the output voltage to rise from 10 % to 90 % of the rating when the output is turned on.

\*8 The time it takes for the output voltage to fall from 90 % to 10 % of the rating when the output is turned off.

\*9 J2 connector on the rear panel.

\*10 Photocoupler open collector output. Maximum voltage 30 V, maximum current (sink) approx. 5 mA. Insulated from the output and control circuits. Status signals are not mutually insulated.

\*11 See the rating of the fuse in the specification of "Protection function".

## 7.3 Dimension Diagram

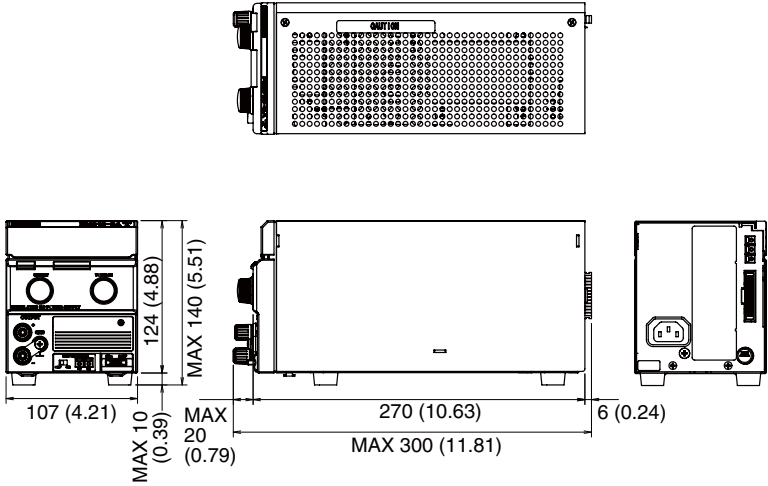

Fig. 7-1 PMC-A Type I Dimension diagram Unit: mm (inch)

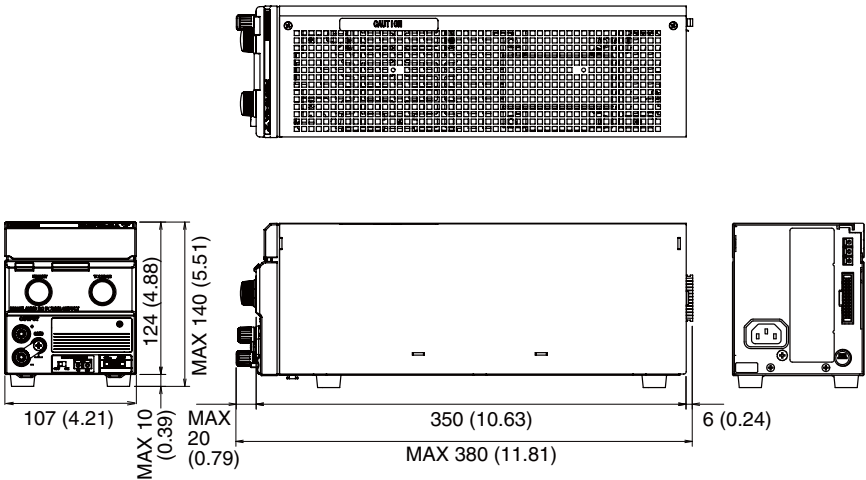

Fig. 7-2 PMC-A Type II Dimension diagram Unit: mm (inch)