

INSTRUCTION MANUAL

FOR

ELECTRONIC LOAD

MODEL PLZ1002W

KIKUSUI ELECTRONICS CORPORATION

865490

Power Requirements of this Product

Power requirements of this product have been changed and the relevant sections of the Operation Manual should be revised accordingly.

(Revision should be applied to items indicated by a check mark)

Input voltage

The input voltage of this product is _____ VAC,
and the voltage range is _____ to _____ VAC. Use the product within this range only.

Input fuse

The rating of this product's input fuse is _____ A, _____ VAC, and _____.

WARNING

- To avoid electrical shock, always disconnect the AC power cable or turn off the switch on the switchboard before attempting to check or replace the fuse.
- Use a fuse element having a shape, rating, and characteristics suitable for this product. The use of a fuse with a different rating or one that short circuits the fuse holder may result in fire, electric shock, or irreparable damage.

AC power cable

The product is provided with AC power cables described below. If the cable has no power plug, attach a power plug or crimp-style terminals to the cable in accordance with the wire colors specified in the drawing.

WARNING

- The attachment of a power plug or crimp-style terminals must be carried out by qualified personnel.

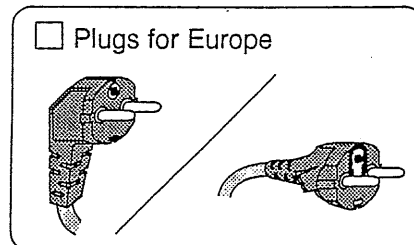
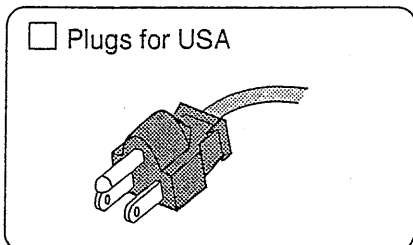
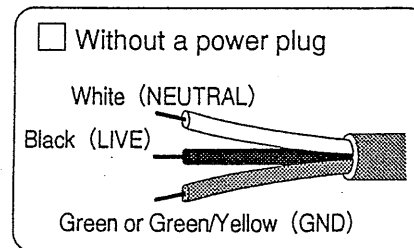
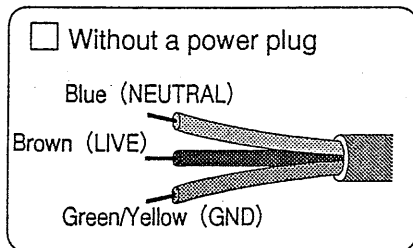

Provided by Kikusui agents
Kikusui agents can provide you with suitable AC power cable.
For further information, contact your Kikusui agent.

Another Cable _____

TABLE OF CONTENTS

| | <u>PAGE</u> |
|---|-------------|
| 1. GENERAL | 1 |
| 1.1 Description | 1 |
| 1.2 Specifications | 3 |
| 2. OPERATION METHOD | 6 |
| 2.1 General Precautions | 6 |
| 2.2 Panel Description | 9 |
| 2.3 Initial Setting | 12 |
| 2.4 Constant Current Mode | 13 |
| 2.5 Constant Resistance Mode | 14 |
| 2.6 Switching Mode | 15 |
| 2.7 External Sensing with Voltmeter | 16 |
| 2.8 Remote Control When in Constant Current Mode | 17 |
| 2.9 Remote Control When in Constant Resistance Mode ... | 19 |
| 2.10 Master-Slave Parallel Operation | 19 |
| 3. OPERATING PRINCIPLES | 22 |
| 3.1 Constant Current Operation | 22 |
| 3.2 Constant Resistance Operation | 22 |
| 3.3 Block Diagram of PLZ1002W | 23 |
| 4. MAINTENANCE | 24 |
| 4.1 Cleaning the Dust Filter | 24 |
| 4.2 Removing the Case Cover | 24 |
| 4.3 Inspection and Cleaning | 25 |
| 4.4 Calibrating the Voltmeter | 25 |
| 4.5 Calibrating the Ammeter | 26 |
| 4.6 Range Calibration for (0.02 /0.2) Constant Current Mode | 27 |

8710 31

86549271

| | | |
|------|---|----|
| 4.7 | Range Calibration (200A/20A) for Constant Current Mode | 27 |
| 4.8 | Calibration of Remote Control Voltage for Constant Current Mode | 28 |
| 4.9 | Adjustment of Maximum Current | 29 |
| 4.10 | Adjustment of Overvoltage Protector (OVP) | 29 |
| 4.11 | Adjustment of MONITOR Output | 30 |
| 4.12 | Troubleshooting | 31 |
| 4.13 | Layout Diagram | 33 |
| 5. | OPTIONS | 34 |
| 5.1 | Rack Mount and Brackets | 34 |

1. GENERAL

1.1 Description

Model PLZ1002W Electronic Load is rated for loading voltage 3 - 110 volts, loading current 0 - 200 amperes, and wattage 1000 watts. The PLZ1002W can be operated either in a constant current mode or in a constant resistance mode.

The PLZ1002W allows dynamic load test by switching between two different levels of load current with its internal oscillator and electronic switching circuit. This function is available when in either the constant current or resistance mode.

The PLZ1002W is incorporated with protectors against overvoltage, overcurrent, overpower, and reverse polarity connection. It has a digital voltmeter/ammeter of 3-1/2 digits. It has a fan for forced air cooling.

Features

- (1) The PLZ1002W employs power MOS FET, thereby eliminating secondary breakdown and improving the reliability.
- (2) A digital voltmeter/ammeter of 3-1/2 digits is provided.
- (3) Two 10-turn helical potentiometers are provided to set individual levels of loading current.
- (4) The loading current can be switched between two different levels, thereby allowing dynamic load test.
- (5) The loading current can be remote-controlled with a voltage signal (when in the constant current mode) or with a resistance signal (when in the constant current or resistance mode).

- (6) Two or more units of PLZ1002W can be operated in parallel in a master-slave mode.
- (7) The PLZ1002W is incorporated with protectors against overvoltage, overcurrent, overpower, overheat, and inverted connections of input. These protectors reset automatically.
- (8) The PLZ1002W is incorporated with a rapid-response rush current suppression circuit.
- (9) Optional frames and brackets are available to install the PLZ1002W on a rack of the EIA Standard or the JIS Standard.

865495

1.2 Specifications

| Item | | Specification |
|--------------------------|-------------------------------------|---|
| Model | | PLZ1002W |
| Power Requirements | Input voltage | 100 V AC $\pm 10\%$ (Standard AC input) * Note 50/60/ Hz AC, single phase |
| | Power consumption | Approx. 70 VA (with 100 V AC line voltage) |
| Load Input | Loading voltage/ current | 3 - 110 V DC (0 - 200 A DC) 2 - 110 V DC (0 - 100 A DC) |
| | Allowable loading power | 1000 W |
| Operation Modes | Constant current mode | Two ranges of 0 - 200 A and 0 - 20 A, continuously variable |
| | Constant resistance mode | Two ranges of 0.02 - 0.4 Ω and 0.2 - 4 Ω or over, continuously variable |
| Constant Current Mode | 3 - 110 V change of loading voltage | $\pm 0.1\% + 20$ mA (at loading current 3 A) |
| | $\pm 10\%$ change of line voltage | $\pm 0.1\% + 20$ mA of setting current |
| | Ripple noise | 50 mA rms (5 Hz - 1 MHz) |
| | Temperature coefficient (typical) | Approx. 0.01%/°C |
| | Rise-time/fall-time | 400 μ s or faster (at load current 0 - 200 A) |
| Constant Resistance Mode | Temperature coefficient (typical) | Approx. 0.01%/°C |
| | $\pm 10\%$ change of line voltage | $\pm 0.1\% + 5$ mA of setting current |

* Note Optional AC input of 120 V $\pm 10\%$, 220 V $\pm 10\%$ or 240 V $\pm 10\%$

865496

| Item | | Specification |
|-------------------------------|------------------------------|--|
| Remote Control | Constant current mode | With external voltage Control of 0 - 200 A with 0 - 10 V (Input impedance approx. 10 k Ω) |
| | | With external re-sistance With 0 - 5 k Ω |
| | Constant re-sistance mode | With external re-sistance With 0 - 5 k Ω |
| Protectors | Overvoltage protector | Cuts out load input at approximately 115 V DC |
| | Overcurrent protector | Cuts out load input at approximately 210 A DC |
| | Overpower protector | Cuts out load input at approximately 1050 W |
| | Reverse connection protector | Checks reverse current with series diode |
| | Overheat protector | Cuts out load input at 100 \pm 5 deg C |
| | AC line power fuse | 2 A |
| Digital Voltmeter/ Ammeter | Maximum effective display | 1999 |
| | Ammeter accuracy | \pm (0.5% of rdg + 0.1% of FS + 1 digit) at 23 $^{\circ}$ C \pm 5 $^{\circ}$ C, 85% RH or less |
| | Voltmeter accuracy | \pm (0.1% of rdg + 0.1% of FS + 1 digit) at 23 $^{\circ}$ C \pm 5 $^{\circ}$ C, 85% RH or less |
| | Range select | Automatic range select |

| Item | | Specification |
|-------------------------------------|------------------|---|
| Oscillator for Switching | Switching period | Two ranges: 5 ms - 50 ms, 50 ms - 500 ms |
| Parallel Operation | | In master-slave mode |
| Current Monitor Output | | 1 mV/A, BNC connector |
| Overpower Indicator | | Yellow LED (blink) |
| Overvoltage and Overpower Indicator | | Red LED |
| Ambient Temperature and Humidity | | 0 to 40 deg C (32 to 104 deg F), 10 to 90% RH |
| Cooling System | | Forced air cooling with fan |
| Dielectric Strength | | ±250 V DC between DC input terminal and chassis |
| Insulation Resistance | | Between DC input terminal and chassis: 20 MΩ or more as tested with 500 V DC Between AC line and chassis: 30 MΩ or more as tested with 500 V DC |
| Withstanding Voltage | | Between AC line and chassis: 1500 V DC, 1 minute |
| Dimensions (Including Extrusions) | | 430(455)W × 146(165(H) × 400(495)D mm 16.92(17.91)W × 5.75(6.50)H × 15.75(19.49) in. |
| Weight | | Approx. 17.5 kg (39 lbs) |
| Accessories | | Power cord 1 |
| | | Instruction manual 1 |
| | | Guard caps 2 |
| | | Dust filter 1 |
| | | Filter seal 1 |

2. OPERATION METHOD

2.1 General Precautions

To prevent damage to the Load, pay attention to the general precautions given in this section.

(1) AC Line Voltage

Make sure that the AC-line voltage is 90 - 110 V (at standard AC input), 48 - 62 Hz, single phase.

(2) Loading Input Voltage

The allowable load is rated for the maximum loading current 200 amperes and wattage 1000 watts.

The allowable loading input voltage is 3 - 110 V DC. When the voltage has exceeded approximately 115 V, the overvoltage protector (OVP) will trip. Refrain from attempting to apply an overvoltage to the Load. Never apply a overvoltage higher than 150 V to the Load. (See Figure 2-1-1.)

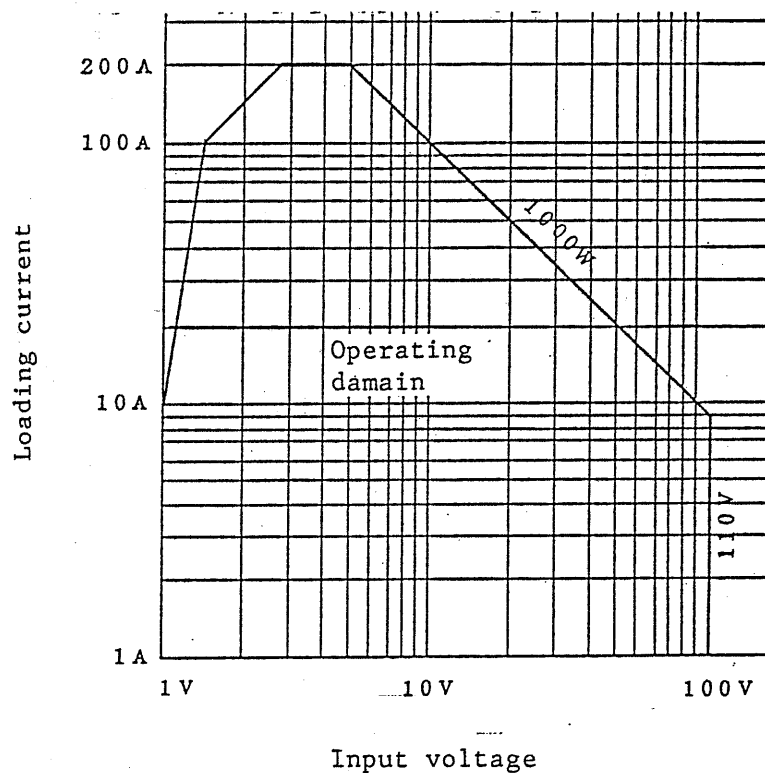

87.10.31

865499A

(3) Loading Wires

For the wires to connect the Load to the power source to be tested, use wires of cross sectional area 80 mm^2 or more and length not longer than 3 meters. If the wires are too small or too long, the the resistance or inductance of the wires will increase and a large voltage drop will be caused, thereby making narrower the operating range of the Load. To connect a distance longer than 3 meters, use wires of correspondingly larger sectional area. Strand the two wires as shown in Figure 2-1-2.

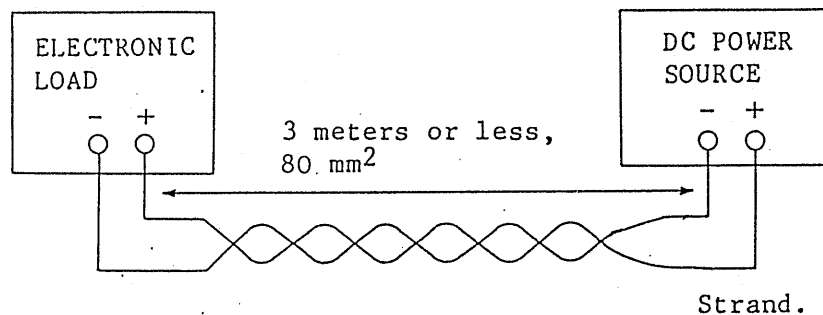

Figure 2-1-2

(4) Ambient Temperature and Humidity

The Load is operable safely and to the performance specifications within a temperature range of 0 to 40 deg C (32 to 104 deg F) and a humidity range of 10 to 90% RH. Pay attention so that the cooling air intake/outlet openings are not blocked. Clean periodically the filter of the air intake opening.

(5) Environments

The place of use of the Load should be without corrosive gases, and should be reasonably free from dust and mechanical vibration.

865500

(6) Rear Terminal Block

Make it double sure that the shorting pieces of the rear terminal block are securely connected as shown in Figure 2-1-3. Note that the Load will not properly operate unless these shorting pieces are connected securely and correctly.

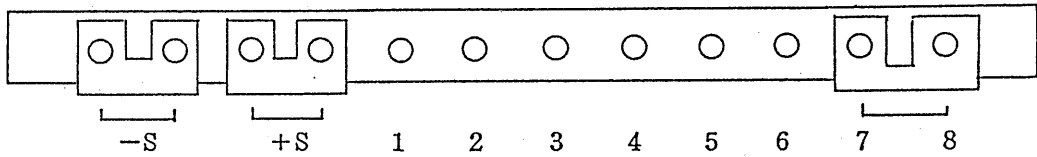
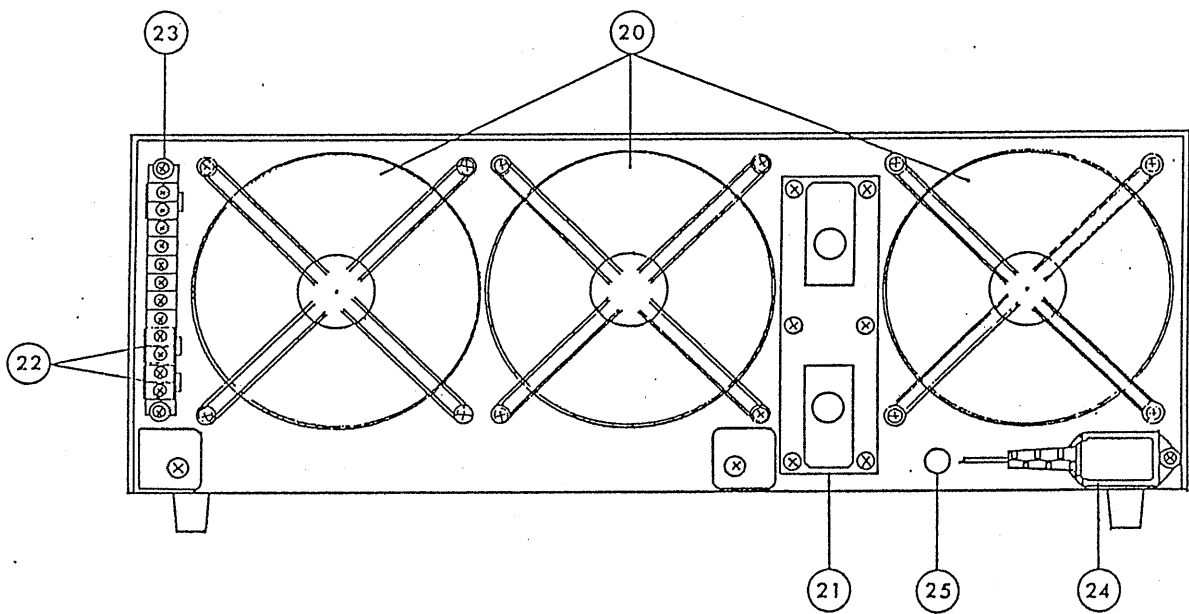
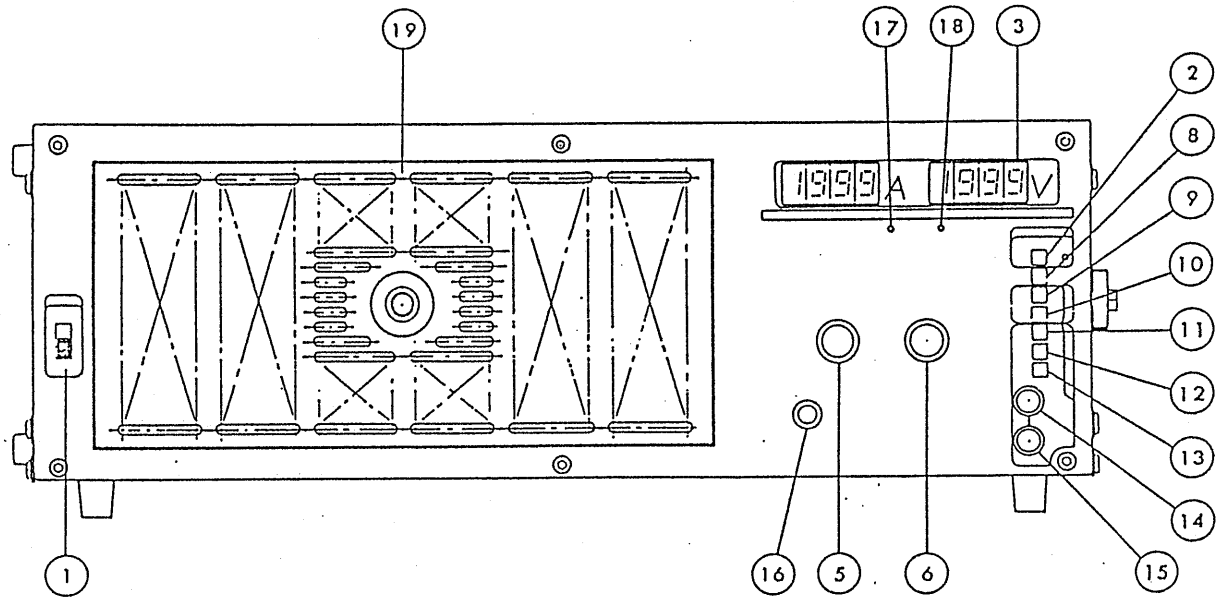

Figure 2-1-3

865501

2.2 Panel Description



865502

- ① POWER: AC line power switch
- ② LOAD: Loading input switch. Automatically trips when overvoltage or overheating is caused. Red LED illuminates when in the ON status.
- ③ VOLTMETER/
AMMETER: Digital voltmeter/ammeter of 3-1/2 digits, with auto-range function
- ⑤ LOAD A: 10-turn potentiometer to control loading current A in the constant current or resistance mode
- ⑥ LOAD B: 10-turn potentiometer to control loading current B in the constant current or resistance mode
- ⑧ INT EXT: Switch to select the local mode or the remote mode when in the constant current mode
- ⑨ CC CR: Switch to select the constant current (CC) mode or the constant resistance (CR) mode
- ⑩ 200A 20A
.02Ω .2Ω Range selector switch
- ⑪ LOAD A LOAD B: Switch to select load A or load B
- ⑫ DC SW: Switch to select the DC loading current or the switched loading current
- ⑬ 5-50 50-500 mS: Switch to select a switching period of loading current
- ⑭ A: To control the period of loading current set by LOAD A ⑤
- ⑮ B: To control the period of loading current set by LOAD B ⑥

8655023

- ①⑥ MONITOR 1mV/A: This terminal delivers a signal to monitor the switched loading current using an oscilloscope.
- ①⑦ ALARM: This lamp illuminates when the overvoltage (110 V or over) protector or the overheat protector has tripped.
- ①⑧ POWER LIMIT: This lamp blinks when the loading input power has exceeded 1000 watts.
- ①⑨ Air intake: Cooling air intake louver
- ②⑩ Air outlet: Cooling fan air outlet
- ②⑪ DC INPUT -, +: Loading input terminal
- ②⑫ -S, +S: Voltmeter input terminals, which are connected to DC INPUT terminals ②⑪ with shorting pieces
- ②⑬ Control terminal block: For the following functions:
- (1) Control with voltage when in the constant current mode
 - (2) Control with external resistance signal when in the constant current or resistance mode.
 - (3) Master-slave parallel operation
 - (4) Sensing for voltmeter
- ②⑭ AC xxxV 50/60Hz: AC line input power cord connector
- ②⑮ FUSE xA: AC line input power fuse

2.3 Initial Setting

Before turning on the POWER switch, set the panel switches and controls as shown in the following table.

| Switch or Control | No. | Setting |
|--|-----|-------------------------|
| LOAD switch | ② | OFF (■) |
| LOAD A | ⑤ | Fully counterclockwise. |
| LOAD B | ⑥ | Fully counterclockwise |
| INT <input type="checkbox"/> EXT switch | ⑧ | INT (■) |
| CC <input type="checkbox"/> CR switch | ⑨ | CC (■) |
| 200A <input type="checkbox"/> 20A .02Ω <input type="checkbox"/> .2Ω switch. | ⑩ | 200A (■) |
| A <input type="checkbox"/> B switch | ⑪ | A (■) |
| DC <input type="checkbox"/> SW switch | ⑫ | DC (■) |
| 5-50 <input type="checkbox"/> 50-500 mS switch | ⑬ | 5-50 (■) |
| TIME A | ⑭ | Mid-position |
| TIME B | ⑮ | Mid-position |

After the above initial setting is over, turn on the POWER switch.

2.4 Constant Current Mode.

Features of the constant current mode of operation are as follows:

- o The Load draws a constant current.
- o The loading current can be switched for dynamic test.

(1) Connection to DC Power Source

Connect the DC power source to be tested to the Electronic Load as shown in Figure 2-4-1.

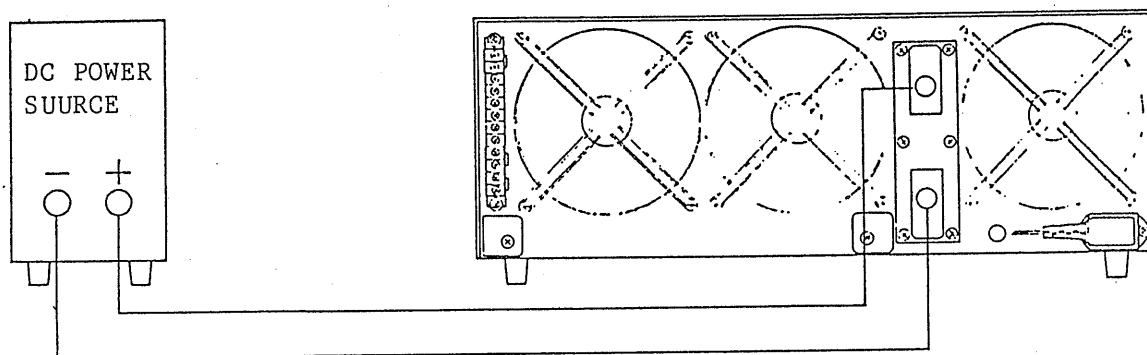
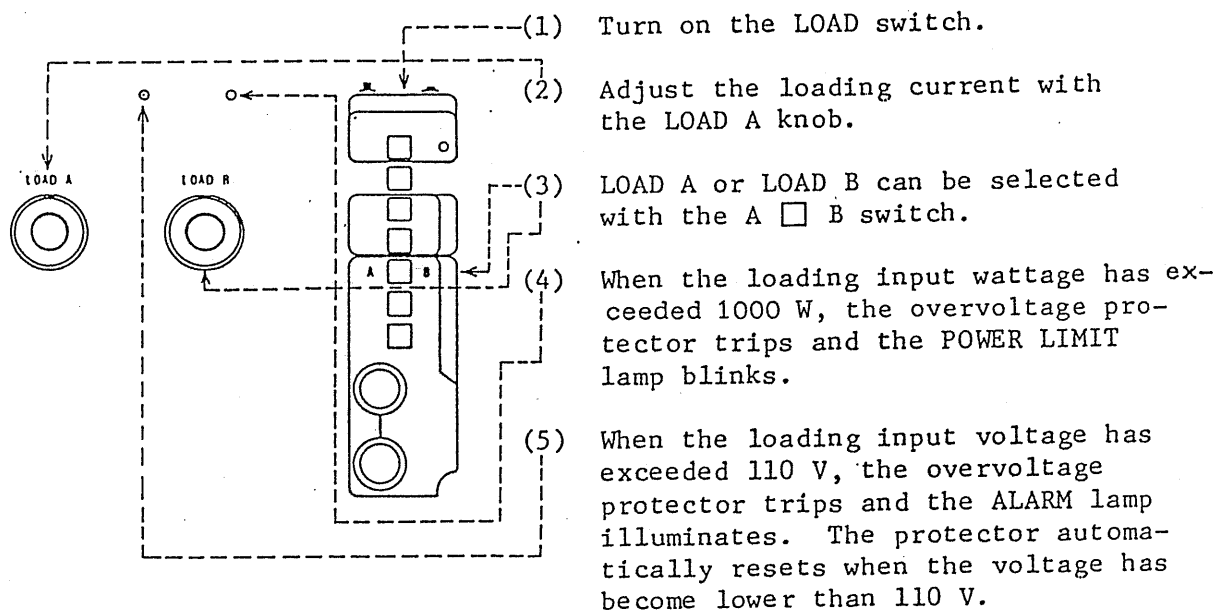

Figure 2-4-1



2.5 Constant Resistance Mode

When in this mode the Electronic Load operate as a resistive load with characteristics as shown in Figure 2-5-1. The resistance is continuously variable with the LOAD A or LOAD B knob. The loading current can be switched for dynamic test.

0.02 Ω range: 0.02 - 0.2 Ω or more, continuously variable

0.2 Ω range: 0.2 - 2 Ω or more, continuously variable

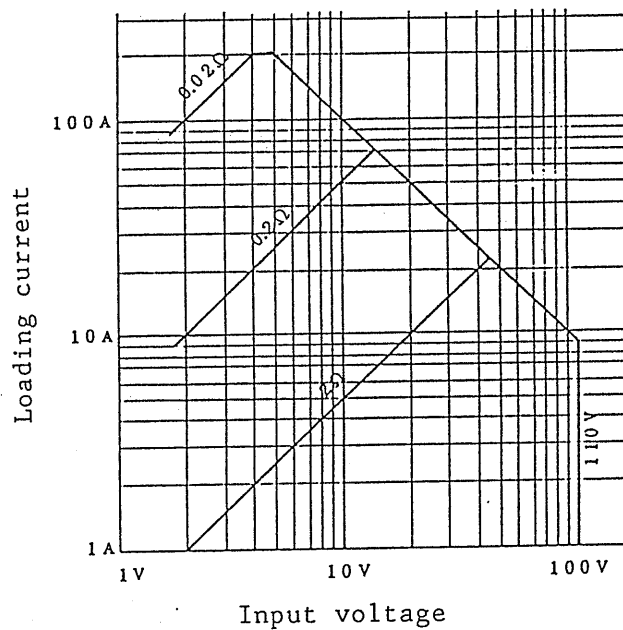
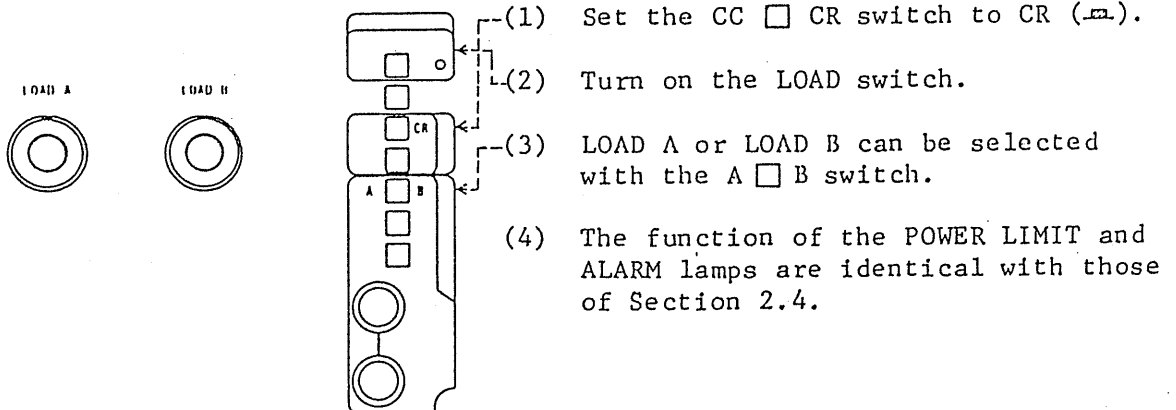

Figure 2-5-1



2.6 Switching Mode

The loading current can be switched for transient response test of a power source. This can be done when the Electronic Load is either in the constant current mode or in the constant resistance mode.

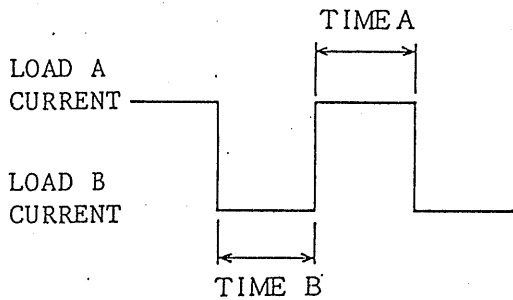
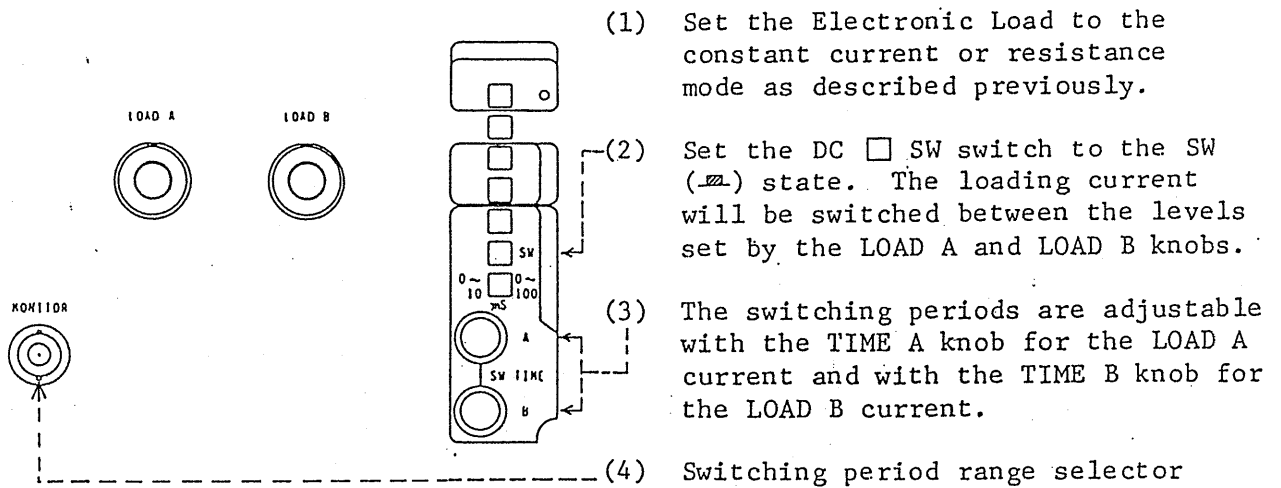

Figure 2-6-1

2.7 External Sensing with Voltmeter

The voltmeter on the front panel of the Electronic Load can be operated for external sensing as described in this section.

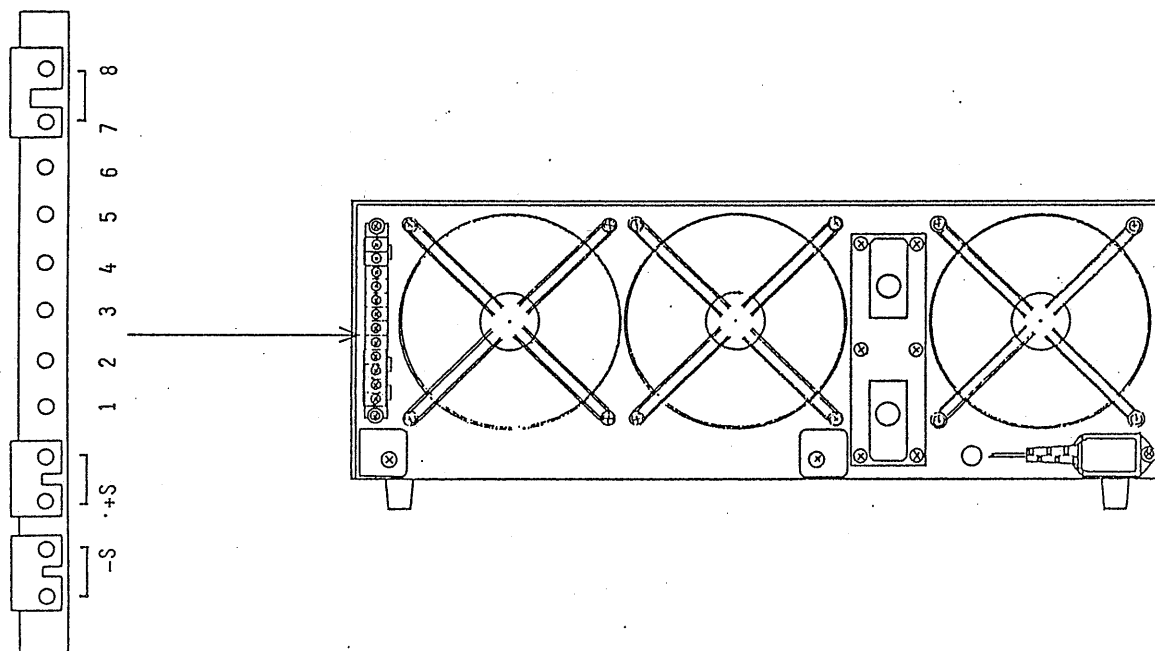

Figure 2-7-1

- (1) The input circuit of the voltmeter is connected to the +S and -S terminals of the control terminal block (23) on the rear panel. See Figure 2-7-1.
- (2) Disconnect the shorting pieces (22) and connect the input circuit of the voltmeter directly to the output circuit of the power source to be tested.

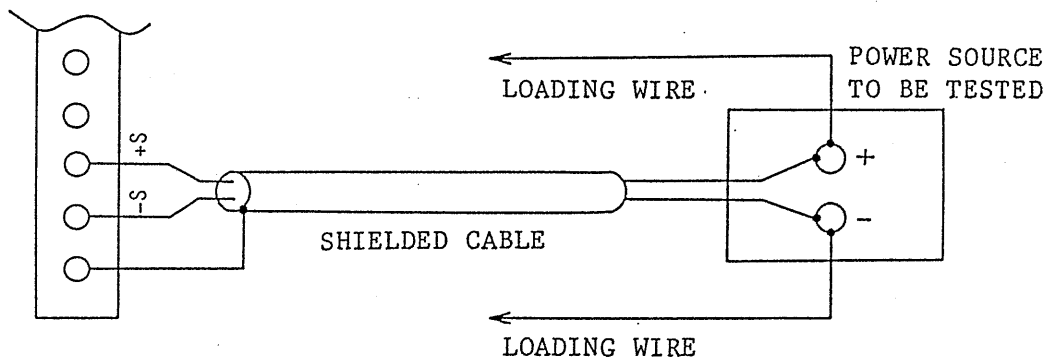

Figure 2-7-2

PRECAUTION: Connect the loading wires to the DC INPUT terminal (21) on the rear panel of the Load. Do not connect them to the control terminals (22).

2.8 Remote Control When in Constant Current Mode

When in the constant current mode, the Load can be remote-controlled with an external voltage or resistance signal.

(1) Remote Control with Voltage Signal

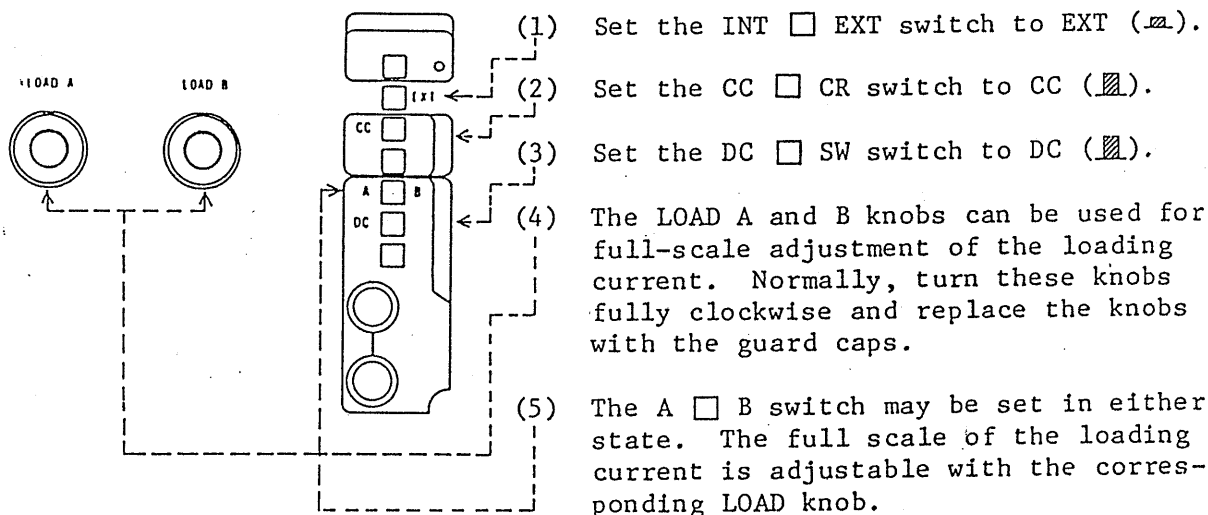

Terminals for external control voltage when in CC mode

Terminals for external control resistance when in CC or CR mode. (Switchover within case is necessary.)

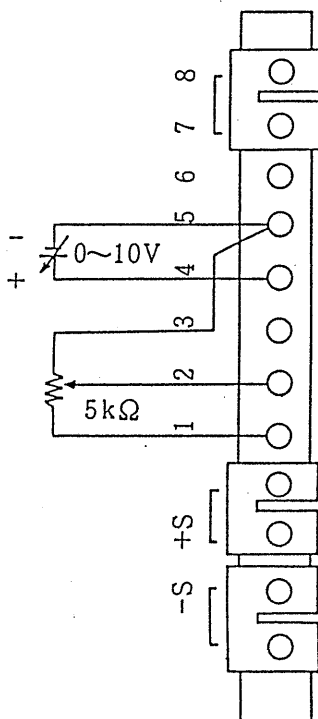

Apply an external control voltage to terminals 4 and 5 of control terminal block (23). (See Figure 2-8-1.)

With an external control voltage of 0 - 10 V, the loading current can be controlled for 0 - 30 A.

Figure 2-8-1

(2) Remote Control with Resistance Signal

The Load can be remote-controlled with an external resistance signal when in the constant current or resistance mode. This remote control mode is equivalent to that the LOAD B potentiometer is extended to an outside of the Load. Therefore, this mode is referred to as "EXT LOAD B" mode.

(1) To set the Load to the EXT LOAD B mode, remove the case cover and change the internal slide switch as shown in Figure 2-8-2.

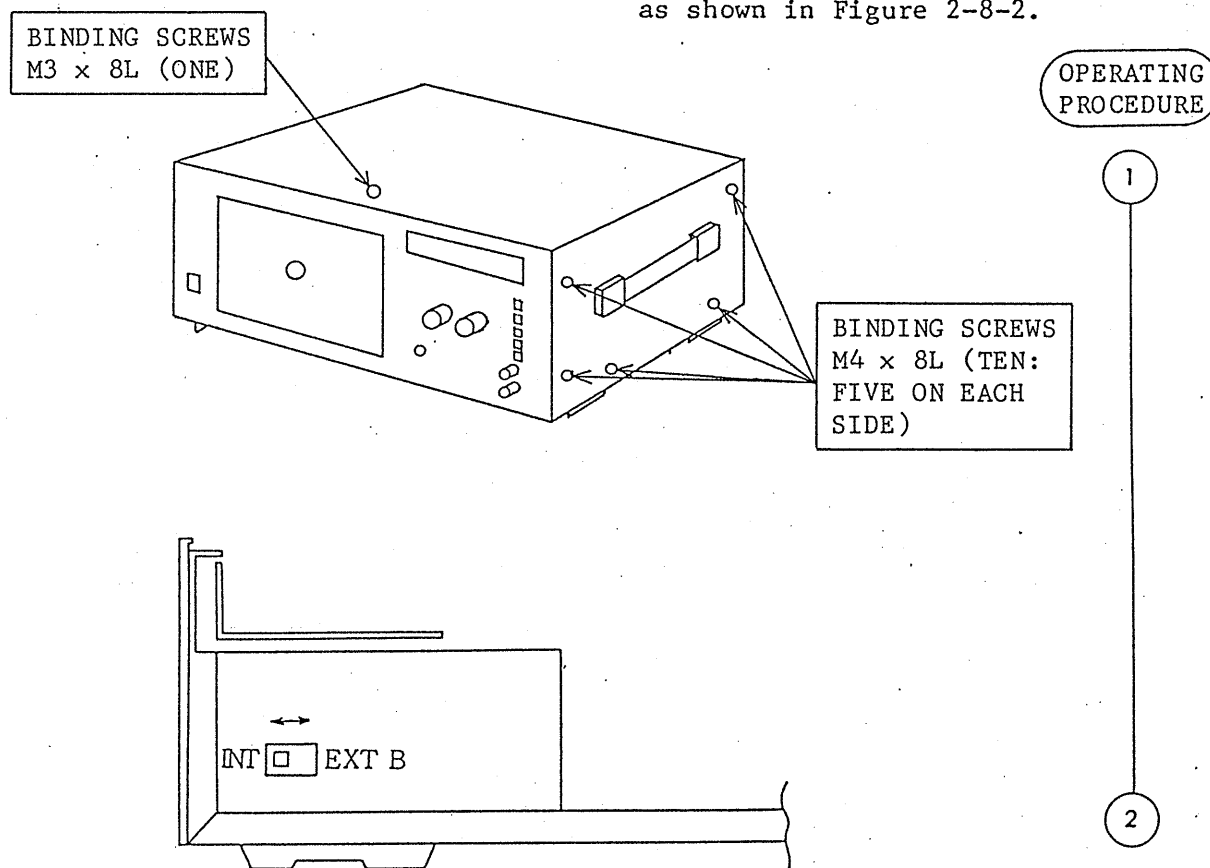

Figure 2-8-2 Slide switch setting

EXT B: For EXT LOAD B mode

PRECAUTIONS: When the Load is not operated in the EXT LOAD B mode, be sure to set the slide switch in the INT state. Be sure to use the specified screws to install the case cover.

8655 11

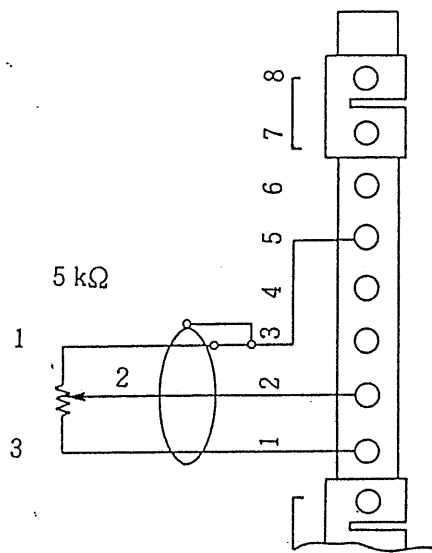
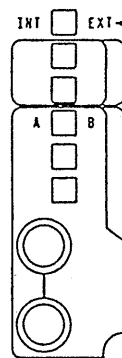
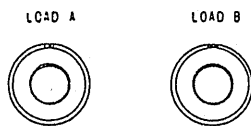

Figure 2-8-3

- (1) For the external resistance signal source, a 5-k Ω 10-turn potentiometer is most recommendable. Connect the potentiometer to the control terminal block (23) as shown in Figure 2-8-3. For this connection, use a shielded cable to guard against noise.

- (2) Set the panel switches as follows:



INT EXT EXT switch: INT ()
 A B switch: B ()

With the above procedure, the Load operates in the EXT LOAD B mode. All other panel switch and control functions except that of the LOAD B knob remain local.

2.9 Remote Control When in Constant Resistance Mode

When in the constant resistance mode, the Load can be remote-controlled with an external resistance signal. For this operation, set the internal slide switch referring to Figure 2-8-2.

2.10. Master-Slave Parallel Operation

Two or more Loads can be operated in parallel for a larger current capacity, with one of them acting as a master unit to dictate the other units.

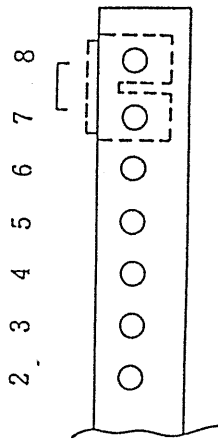

Figure 2-10-1

- (1) Turn off the POWER switch.
- (2) Remove the shorting piece from between terminals ⑦ and ⑧ of the external control terminal block of the slave unit.
- (3) Connect terminal ⑥ of the external control terminal block of the master unit to terminal ⑦ of that of the slave unit.
- (4) Connect in parallel the DC INPUT terminals of the master unit and slave unit(s) as shown in Figure 2-10-2.
- (5) Make sure that the lengths and cross sectional areas of the loading wires are the same ($L_1 = L_2 = L_3$).
- (6) Set the switches and controls of the slave unit(s) as follows:

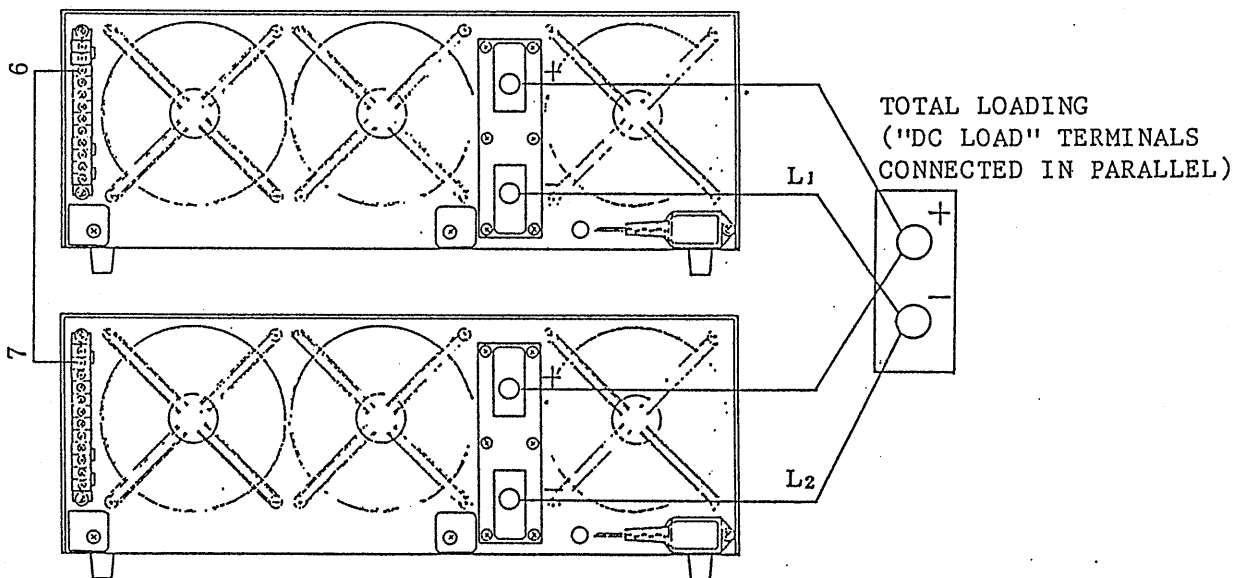
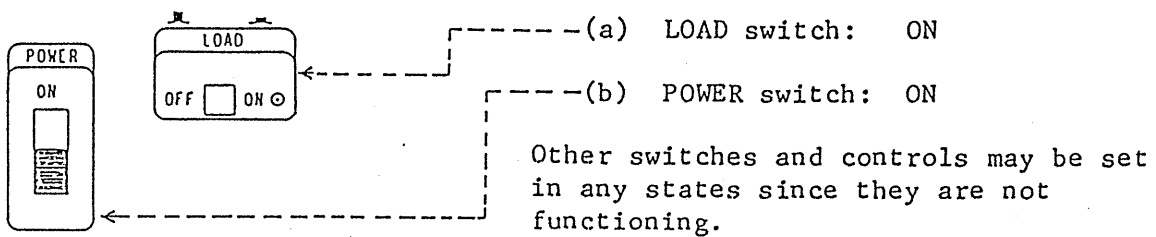

Figure 2-10-2

With the above procedure, the Loads connected in parallel can be operated in a master-slave mode.

Note: The total of the loading currents of the individual Loads connected in parallel is drawn from the power source to be tested. The individual loading currents may differ by approximately $\pm 5\%$.

865514

3. OPERATING PRINCIPLES

3.1 Constant Current Operation

Referring to Figure 4-1-1, the error amplifier controls the loading current (I_{IN}) so that the voltage drop across the current detecting resistor (R_D) becomes equal to the reference voltage (E_{ref}).

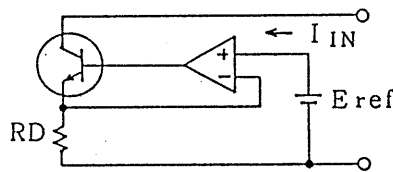

$$I_{IN} = \frac{E_{ref}}{R_D}$$

Figure 4-1-1

Consequently, the loading current (I_{IN}) is determined only by the reference voltage (E_{ref}) and the detecting resistor resistance (R_D) irrespective of the loading voltage, thereby drawing a constant loading current.

3.2 Constant Resistance Operation

Referring to Figure 4-2-1, the error amplifier controls the loading current (I_{IN}) so that it is directly proportional to the loading voltage (E_{IN}).

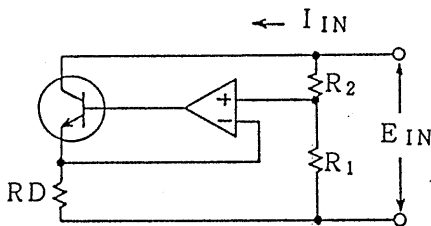

$$I_{IN} = \frac{R_1}{R_1 + R_2} \cdot \frac{E_{IN}}{R_D} = \frac{E_{IN}}{R_E}$$

$$\text{where, } \frac{1}{R_E} = \frac{R_1}{R_1 + R_2} \cdot \frac{1}{R_D}$$

Figure 4-2-1

The equivalent resistance (R_E) as viewed from the input circuit of the Load depends only on the voltage dividing ratio $\frac{R_1}{R_1 + R_2}$ and detecting resistor resistance R_D .

865515

3.3 Block Diagram of PLZ1002W

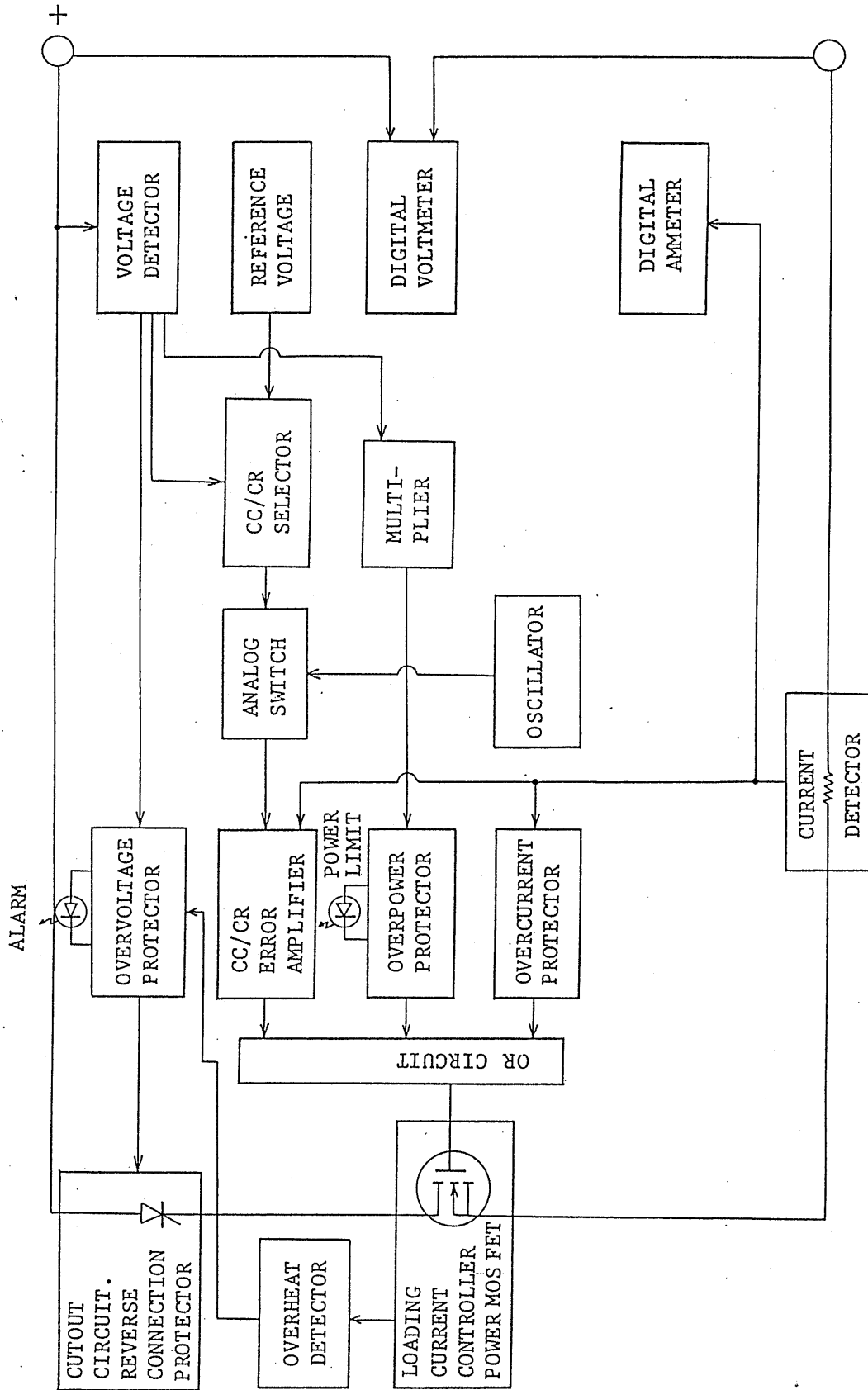

MODEL PLZ 1002W Electronic Load

91.5598

4. MAINTENANCE

The Electronic Load should be inspected, cleaned and calibrated at appropriate intervals. To calibrate the Load, it is most recommendable to order your Kikusui agent since the calibration requires accurate measuring instruments and special skills.

PRECAUTION: The heat sinks of the charged section shown in the layout diagram of Section 4.13 make up part of the circuit. Exercise care not to let the heat sinks shorted to other circuit or ground.

4.1 Cleaning the Dust Filter

Referring to Figure 4-1-1, remove the filter cover and take out the dust filter.

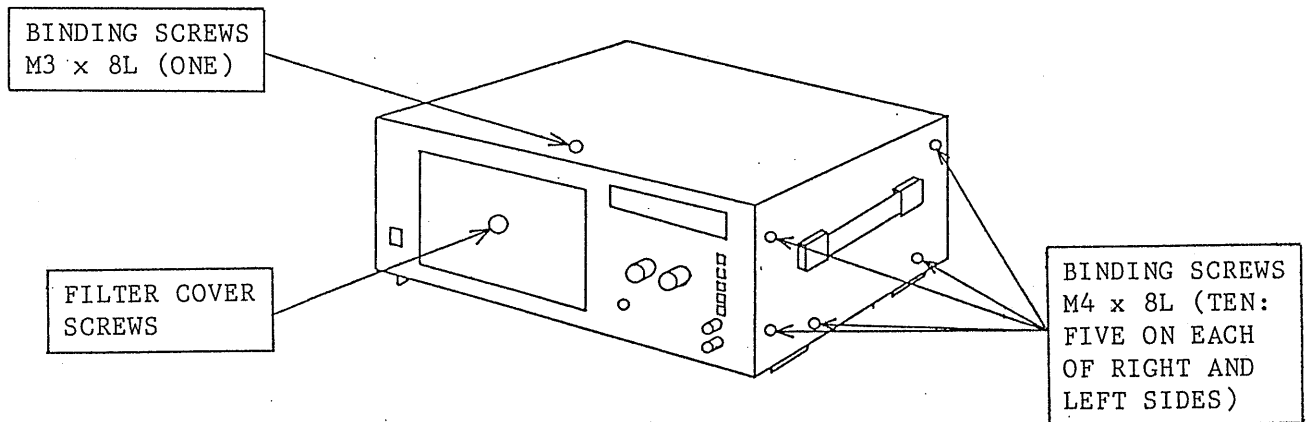

Figure 4-1-1

Clean thoroughly the dust filter and then install it in the original position.

4.2 Removing the Case Cover

Remove the two top screws and four side screws (see Figure 4-1-1) and pull up the cover.

PRECAUTION: Be sure to use the original screws to install the case cover. Note that troubles may result if screws other than the specified ones are used.

4.3 Inspection and Cleaning

(1) When the front panel or case cover panels have become dirty, wipe them using a cloth moistened with a diluted neutral detergent or alcohol, and then wipe them using a dry cloth. Do not use benzine or any kind of thinner. To blow off dust accumulated inside of the case, use a clean and dry compressed air.

(2) Inspecting the Power Cord

Inspect the power cord for damage of the cord and plug.

4.4 Calibrating the Voltmeter

The input circuit of the voltmeter is connected to the +S and -S terminals of control terminal block (23) on the rear panel. Remove the shorting pieces (22) and connect a reference voltage generator to the +S and -S terminals as shown in Figure 4-4-1.

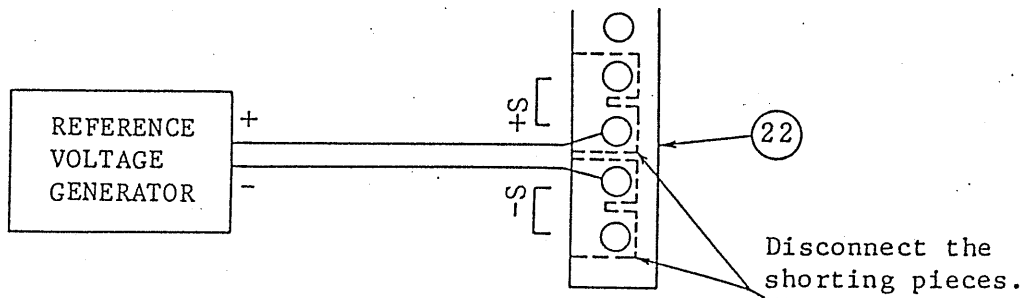

Figure 4-4-1

Calibrate the voltmeter in the order shown in Table 4-4-1.

Table 4-4-1

| Step | Reference Voltage Generator | Adjustment | Voltage Reading | Remarks |
|------|-----------------------------|------------|-----------------|--------------------------|
| 1 | 19.000 V | RV405 | 19.00 V | |
| 2 | 100.00 V | RV406 | 100.0 V | |
| 3 | 19.00 - 19.50 V | RV407 | 19.00 - 19.50 V | Adjustment of auto-range |

Be sure to install the shorting pieces (22) in the original positions after the calibration is over.

4.5 Calibrating the Ammeter

Prepare a calibration setup as shown in Figure 4-5-1.

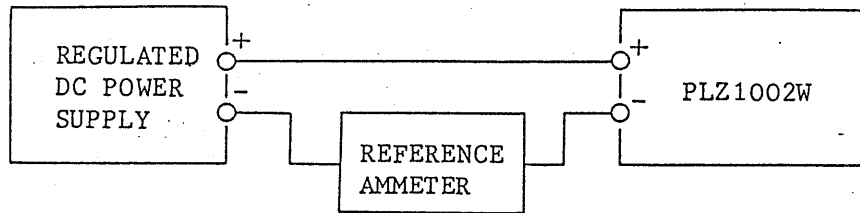

Figure 4-5-1

Calibrate the ammeter in the order shown in Table 4-5-1.

Table 4-5-1

| Step | Reference Ammeter | Adjustment | Ammeter Reading | Remarks |
|------|-------------------|------------|-----------------|---|
| 1 | 190.00 A | RV401 | 190.0 A | Adjust after 5 minutes of stabilization period. |
| 2 | 200.0 A | RV402 | 200 A | |
| 3 | 190.0 - 195.0 A | RV403 | 190 - 195 A | Adjustment of auto-range |

188.11.7
865519

4.6 Range Calibration (0.02 Ω/0.2 Ω) for Constant Resistance Mode

Prepare a calibration setup as shown in Figure 4-6-1.

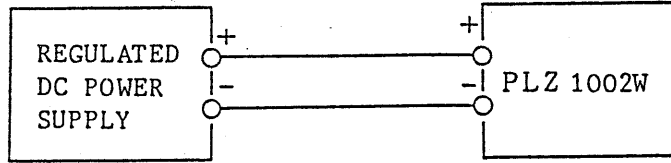

Figure 4-6-1

Adjust RV101 and RV102 in the order shown in Table 4-6-1.

Table 4-6-1

| Step | Item | Setting | Input Voltage | Current | Adjustment |
|------|-----------------|-----------------|---------------|---------|------------|
| 1 | Mode switch | CR (⊘) | 10.00 V | 55.0 A | RV101 |
| | Range switch | 0.2Ω (⊘) | | | |
| | LOAD A | Fully clockwise | | | |
| | LOAD A/B switch | LOAD A (⊘) | | | |
| 2 | Range switch | 0.02Ω (⊘) | 3.00 V | 165 A | RV102 |

Range calibration for the constant resistance mode is complete by the above procedure.

4.7 Range Calibration (200A/20A) for Constant Current Mode

The 200 A range is fixed. Adjust the 20 A range with RV103 in the order shown in Table 4-7-1.

87.10.31

8655207

Table 4-7-1

| Step | Item | Setting | Input Voltage | Current | Adjustment |
|------|--------------|----------|---------------|---------|------------|
| 1 | Mode switch | CC (☒) | / | / | / |
| 2 | Range switch | 200A (☒) | / | / | / |
| 3 | LOAD A | 200A | 3.0 V | 200 A | / |
| 4 | Range switch | 20A (☒) | 3.0 V | 20.0 A | RV103 |

Range calibration for the constant current mode is complete by the above procedure.

4.8 Calibration of Remote Control Voltage for Constant Current Mode

The Load should draw a current of 200 A when a remote control voltage of +10 V is applied. Adjust RV106 and RV107 in the procedure shown in Table 4-8-1.

Table 4-8-1

| Step | Item | Setting | Input voltage | Current | Adjustment |
|------|----------------------------------|--|---------------|---------|------------|
| 1 | Mode switch | CC (☒) | / | / | / |
| 2 | Range switch | 200A (☒) | / | / | / |
| 3 | LOAD A | 200A | / | / | / |
| 4 | DC INPUT | Voltage supply | 3.0 V | / | / |
| 5 | INT <input type="checkbox"/> EXT | EXT (☒) | 3.0 V | / | / |
| 6 | Control terminal block (23) | Apply 10.0 V between 4 and 5. | 3.0 V | / | / |
| 7 | Adjustment of RV106 | Adjust at 200 A | 3.0 V | 200 A | RV106 |
| 8 | Offset adjustment with RV107 | Change to 0 V the voltage between 4 and 5. | 3.0 V | 0.1 A | RV107 |

865521

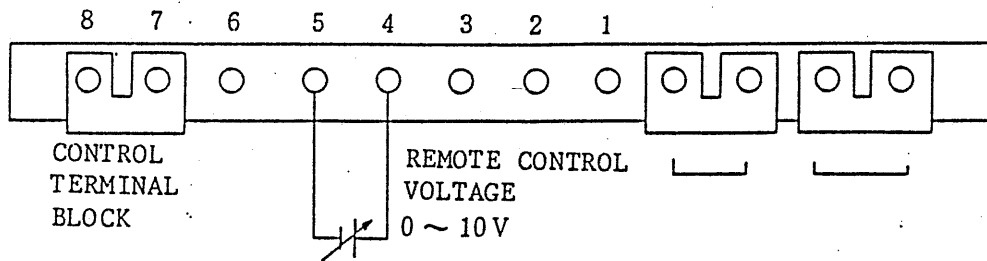

Figure 4-8-1

Calibration of the remote control voltage for the constant current mode is complete by the above procedure.

4.9 Adjustment of Maximum Current

This adjustment is for the protective circuit which limits the maximum loading current at 205 - 215 A in order to protect the components against deterioration and damage which could be caused by overcurrent. Adjust RV113 as shown in Table 4-9-1.

Table 4-9-1

| Step | Item | Setting | Input voltage | Current | Adjustment |
|------|--|---|---------------|-------------|------------|
| 1 | INT <input type="checkbox"/> EXT | INT (<input checked="" type="checkbox"/>) | / | / | / |
| 2 | LOAD A <input type="checkbox"/> LOAD B | A (<input checked="" type="checkbox"/>) | / | / | / |
| 3 | LOAD A knob | Fully clockwise | / | / | / |
| 4 | DC INPUT | Voltage supply | 4 V | / | / |
| 5 | (Current limiter) | | 4 V | 205 - 215 A | RV113 |

4.10 Adjustment of Overvoltage Protector (OVP)

The OVP trips within a range of 115 - 120 V DC, to cut off the thyristor of the input circuit. Adjust RV112 as shown in Table 4-10-1.

87.10.31

8655222

Table 4-10-1

| Step | Item | Setting | Input Voltage | Current | Adjustment |
|------|----------------------------------|-------------------------|---------------|---------|------------|
| 1 | INT <input type="checkbox"/> EXT | INT (▣) | | | |
| 2 | LOAD switch | ON (⏻) | | | |
| 3 | LOAD A, B knobs | Fully counter-clockwise | | | |
| 4 | DC INPUT | Voltage supply | 115 V | | |
| 5 | OVP | ALARM illuminates. | 115 - 120 V | 0 | RV112 |

4.11 Adjustment of MONITOR Output

The MONITOR terminal delivers a signal (approximately 1 mV/A) which represents the switched loading current. Adjust this signal with RV404 as shown in Table 4-11-1, displaying the signal on a calibrated oscilloscope.

Table 4-11-1

| Step | Item | Setting | Input voltage | Current | Adjustment |
|------|----------------------------------|--------------------------|---------------|-------------|------------|
| 1 | INT <input type="checkbox"/> EXT | INT (▣) | | | |
| 2 | DC INPUT | Voltage supply | 3.0 V | | |
| 3 | LOAD A knob | 100 A | 3.0 V | 100 A | |
| 4 | LOAD B knob | 0 A | 3.0 V | 0 A | |
| 5 | DC <input type="checkbox"/> SW | SW (⏻) | 3.0 V | Square wave | |
| 6 | MONITOR | Output voltage 100 mVp-p | 3.0 V | Square wave | RV404 |

Adjustment of the MONITOR output is complete by the above procedure.

865523

4.12 Troubleshooting

Basic procedures for troubleshooting are shown in Table 4-12-1. When the Electronic Load is found to be malfunctioning, order your Kikusui agent for repair.

Table 4-12-1

| Symptom | Item to be Checked | Probable Cause |
|--|--|---|
| No loading current flows. | 1. Is the ALARM lamp not illuminating? | <ul style="list-style-type: none"> o OVP has tripped. o Overheating due to poor ventilation |
| | 2. Is the POWER LIMIT lamp not blinking? | <ul style="list-style-type: none"> o The loading current has exceeded 1000 watts. |
| | 3. Is the LOAD switch correctly set? | <ul style="list-style-type: none"> o The LOAD switch is set in the OFF state. (Set the switch to the ON state.) |
| | 4. Is the LOAD switch lamp not illuminating? | <ul style="list-style-type: none"> o If the LOAD switch is off, the Load is overheated. (Cool off the Load and then turn on the POWER switch.) |
| | 5. Is the INT <input type="checkbox"/> EXT switch correctly set? | <ul style="list-style-type: none"> o The switch is set to EXT. (Set it to INT.) |
| | 6. Are the shorting pieces of control terminal block (23) correctly fixed? | <ul style="list-style-type: none"> o Loose or disconnected shorting pieces |
| The loading current is not adjustable. | 1. Is the POWER LIMIT lamp not blinking? | <ul style="list-style-type: none"> o The loading input power has exceeded 1000 watts. |
| | 2. Is the loading current appropriate? | <ul style="list-style-type: none"> o The loading current has exceeded 200 A and the over-current protector has tripped. |
| | 3. Is the A <input type="checkbox"/> B switch correctly set for the LOAD A or LOAD B knob? | <ul style="list-style-type: none"> o The switch is not correctly set for the knob to be used to adjust the loading current. |

865524

| Symptom | Item to be Checked | Probable Cause |
|---|--|--|
| Switching of loading current is unsuccessful. | 1. Is the DC <input type="checkbox"/> SW switch correctly set? | o The switch is set in the DC (<input checked="" type="checkbox"/>) state. (Set it to the SW (<input checked="" type="checkbox"/>) state.) |
| | 2. Are the LOAD A and LOAD B knobs correctly set? | o The setting is in the state of LOAD A = LOAD B. |
| The ALARM lamp illuminates and no loading current flows. | 1. Dust filter | o The dust filter has been clogged and the Load is overheated. (Turn off the POWER switch and clean the filter.) |
| | 2. Loading voltage | o The loading voltage is higher than 110 V and the OVP has tripped. |
| The POWER LIMIT lamp blinks. | 1. Loading voltage and current | o The loading wattage has exceeded 1000 watts and the overpower protector has tripped. |
| Remote control with voltage signal is unsuccessful when in the constant current mode. | 1. INT <input type="checkbox"/> EXT switch | o The switch is set in the INT (<input checked="" type="checkbox"/>) state. (Set it to the EXT (<input checked="" type="checkbox"/>) state.) |
| | 2. Polarity of voltage signal | o Polarity is wrong. (Set it correctly as shown in Figure 2-8-1.) |
| Remote control with resistance signal is unsuccessful. | 1. Setting of the slide switch shown in Figure 2-8-2 | o The switch is set in the INT position. (Change it to the EXT position.) |
| | 2. Control resistor | o Resistance or connection of the control resistor is incorrect. |
| Power of the Load cannot be turned on. | 1. Fuse | o The fuse has blown out. (Replace the fuse (2 amperes).) |

87.10.31

8655257

4.13 Layout Diagram

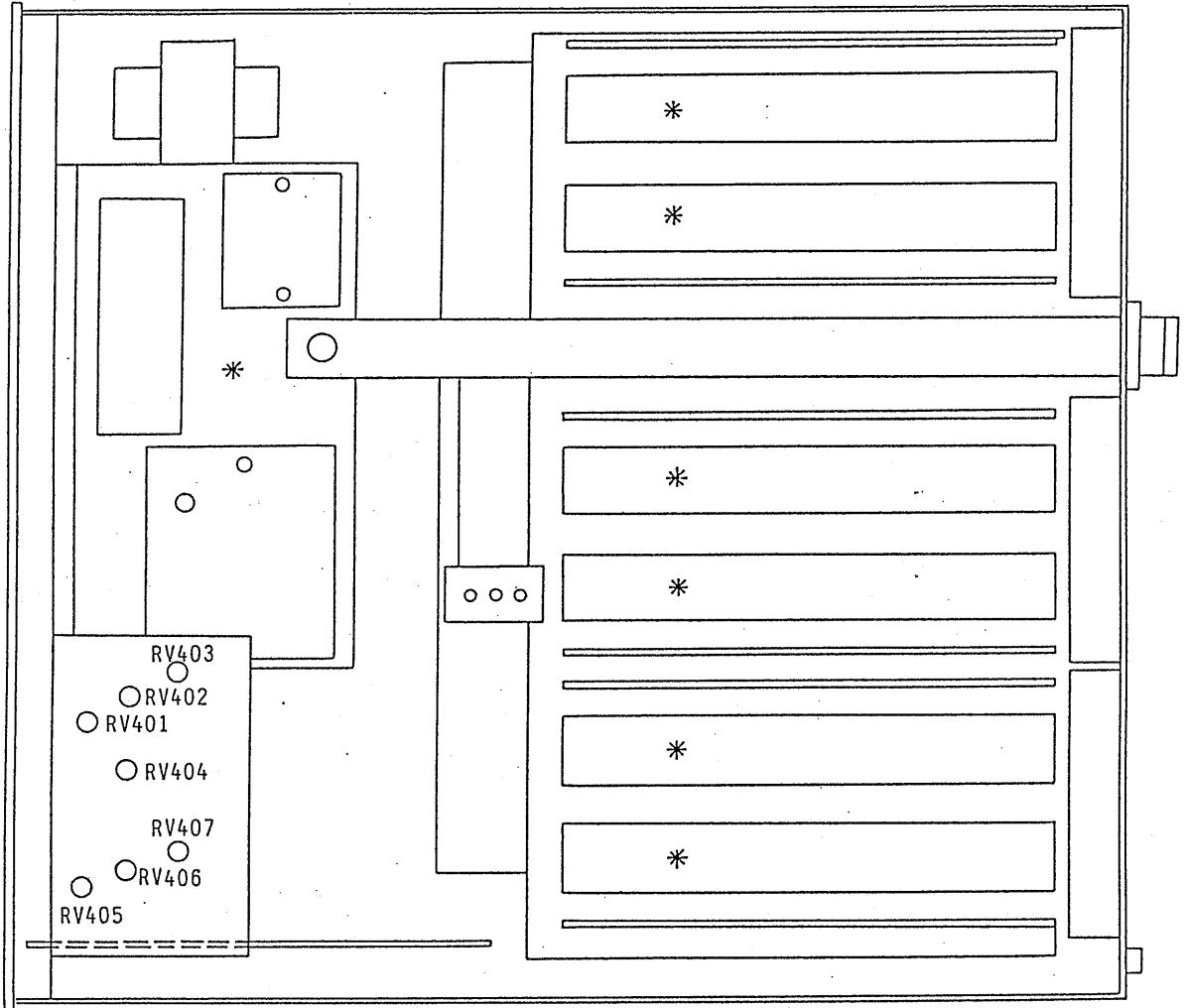

Top View

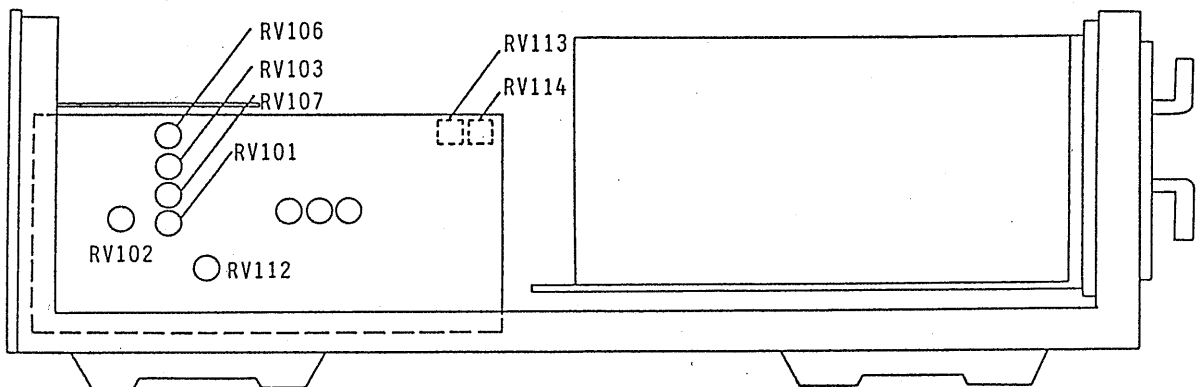

* HEAT SINK OF CHARGED SECTION

Right Side View

865526

5. OPTIONS

5.1 Rack Mount and Brackets

The PLZ1002W can be mounted in a metric rack by using the optional brackets of BH3TM-1 Type or in an inch rack by using the optional brackets of BH4AT-1 Type.

- Notes:
- When attaching the brackets, be sure to remove the rubber legs from the bottom and side.
 - Be sure to use supporting angle steels. Put the angle steels in the rack, set the PLZ1002W on them, and fix it.

- (1) BH3TM-1 Type bracket attaching dimensions and method (for metric rack)

Attaching dimensions

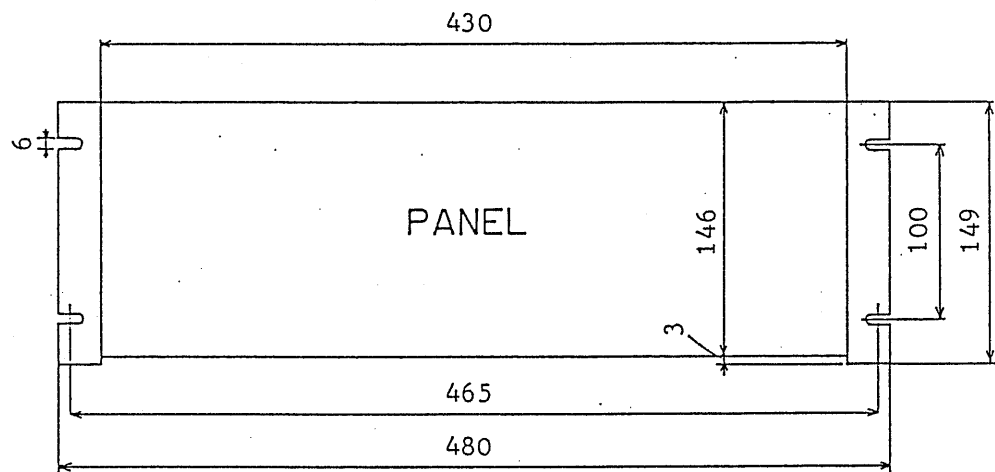

Attaching method

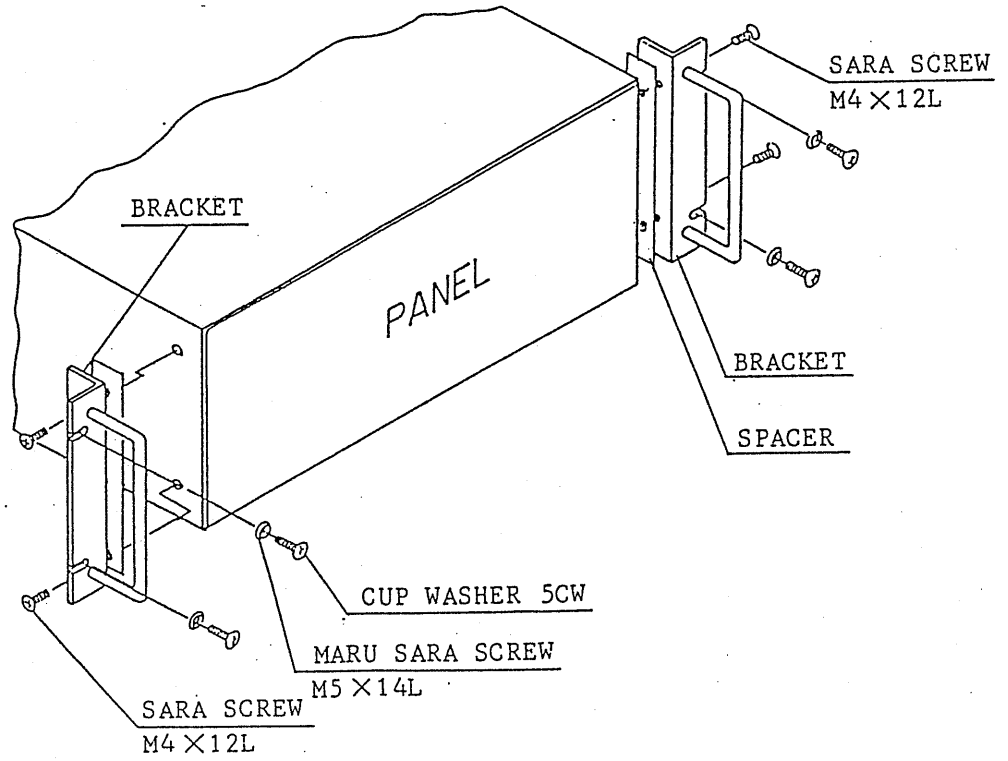

865528

(2) BH4AT-1 Type bracket attaching dimensions and method (for inch rack)

Attaching dimensions

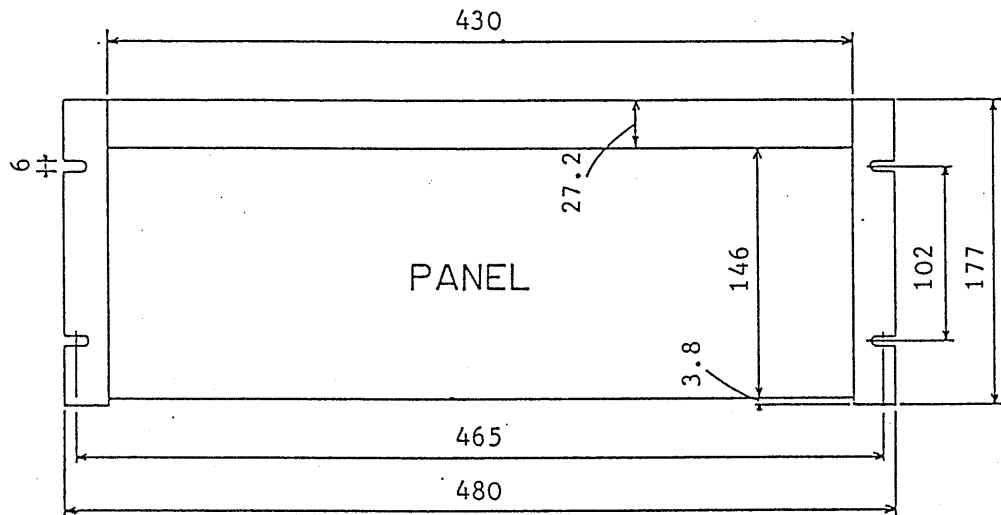

Attaching method

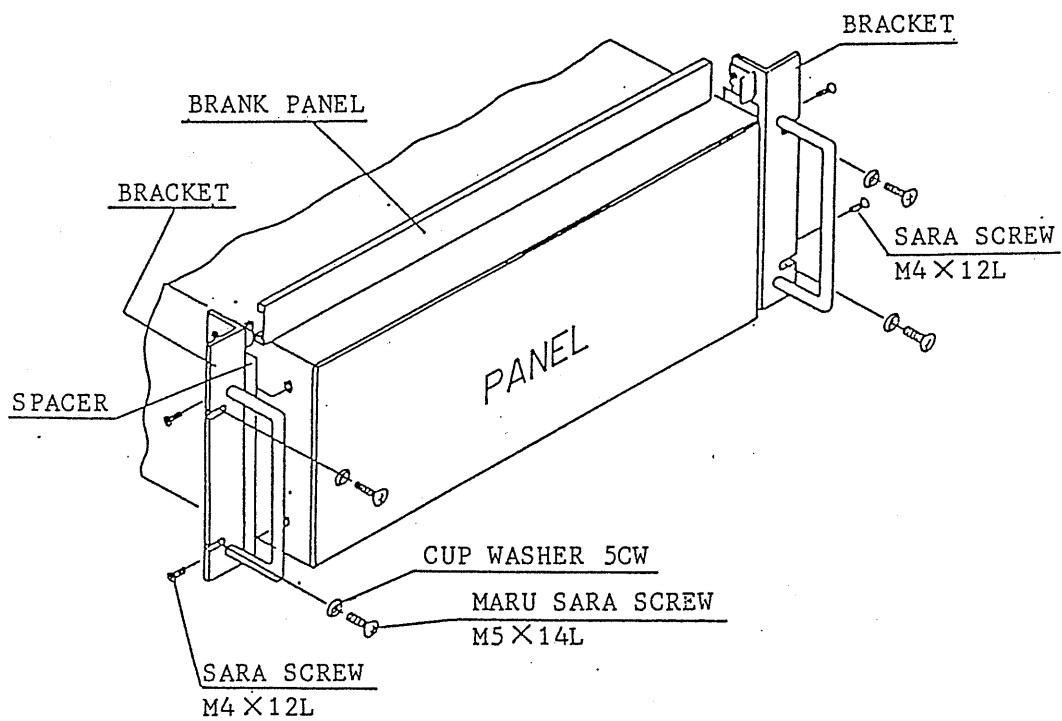

8655290